

# Municipal Utility CHP Case Study

US EPA CHP Partnership  
Webinar

November 20, 2008  
Rod Schwass and Ed Mardiat



# Burns & McDonnell - Overview

---



- 100% Employee Owned
- 2900 Employees
- \$1 Billion Revenue
- Headquartered in Kansas City
- 18 Regional Offices
- DOE Industry Partner CHP Demonstration Project

*Over 110 years of power generation, utility and infrastructure experience*

# Utility Generation/Fuel Portfolio

- Renewable Energy
  - Cost and reliability issues
- Fossil Fuel
  - Our most abundant natural resource
  - New technology and applications
- Reemergence of Nuclear
  - Cost and time issues

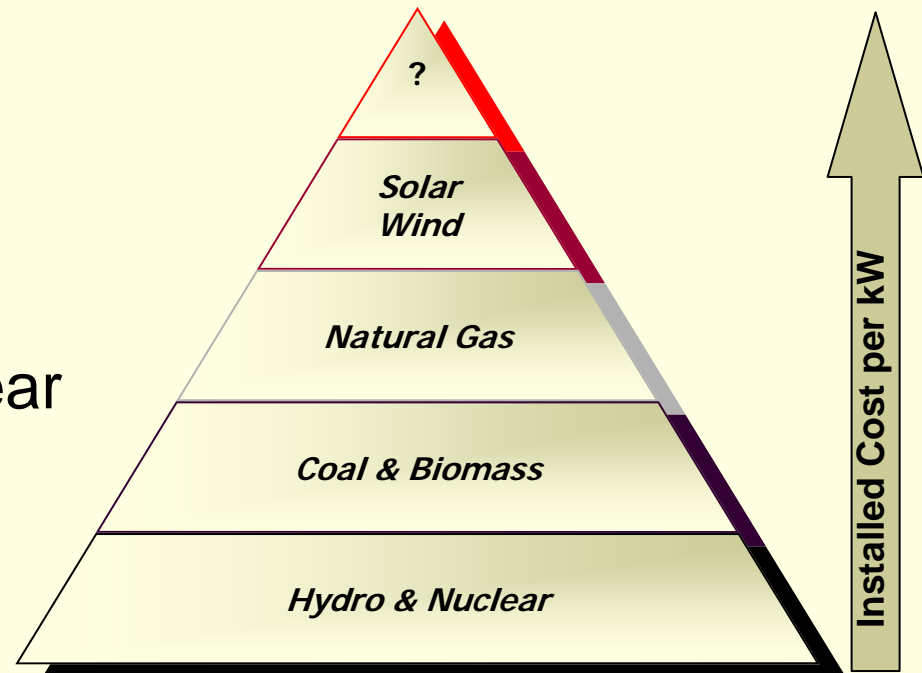

***Heat Rate as Compared to Other Generation Assets***

# CHP - Benefits to Utilities

---

- *“Demand Side Management”* costs less than constructing new conventional power plants.
- Allows for the integration of *“state-of-the-art”* technologies improving efficiency and demonstrating environmental responsibility
- Useful to Utilities for grid power management
- Avoids Utility Investment where the grid is insufficient due to congestion or in rural areas where it is underdeveloped.

# Gainesville Regional Utilities



South Energy Center at  
Shands Cancer Hospital  
Gainesville, FL

# Why Consider CHP at Hospitals?

---

- CHP ***“Best User” Profile*** is:
  - Coincident electrical and thermal loads
  - 24 hour/day, 7 day/week, 365 day/year operation
  - Low Seasonal Variation in loads
  - High Power Reliability Needs
- Hospitals fit the ***“Best User” Profile*** for Combined Heat and Power applications

# GRU South Energy Center

## PROJECT FACTS

**Owner:** Gainesville Regional Utilities

**EPC Contractor:** Burns & McDonnell

**Total Project Cost:** \$45,000,000

**Project Completion:** December 2008

**Hospital Complete:** June 2009



## TECHNOLOGY HIGHLIGHTS

High Heat Rate Efficiency

Low Emissions

Grid Interconnect – Parallel & Island Mode

Integrated Controls System

LEED EA 1 Efficiency Credits for CHP

## FEATURES

State-of-the-Art Technology

Modular & Packaged Components

Built-in Redundancy

Operational Flexibility

## BENEFITS

Increased Efficiency

Improved Reliability

Reduced Emissions

Provides 100% of the Hospital's  
Electrical and Thermal Needs

# Shands Cancer Hospital

## ***Business Case...***

Hospital has selected GRU as its Energy Partner to provide electricity, chilled water, steam and medical gases

GRU South Energy Center is expandable to meet planned future growth of Cancer Hospital

Will also serve Chilled Water to the larger planned “Urban Campus” as part of the South Campus Development

GRU provided bond financing to construct the Energy Center as part of a long-term energy agreement with the hospital. ***\$30M Capital Savings accrued to the Hospital from not building its own Central Plant.***



# In the Beginning...

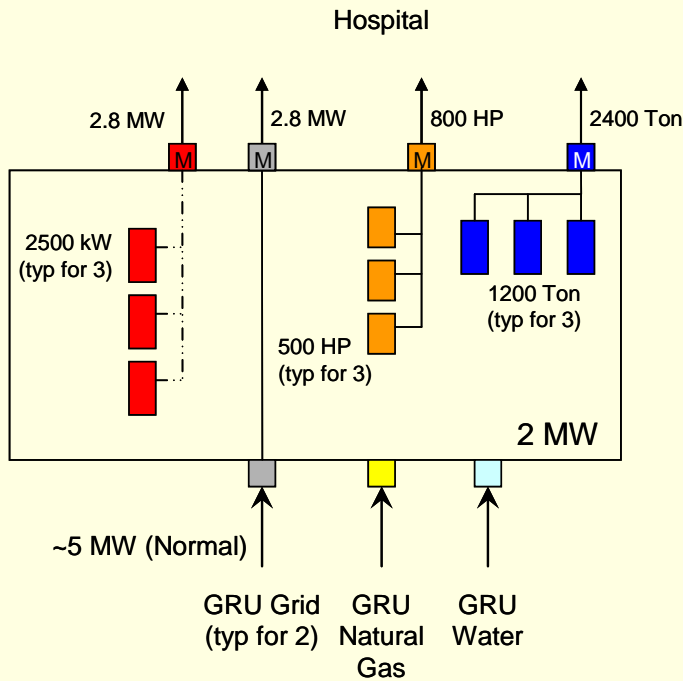

**Base Case CUP**

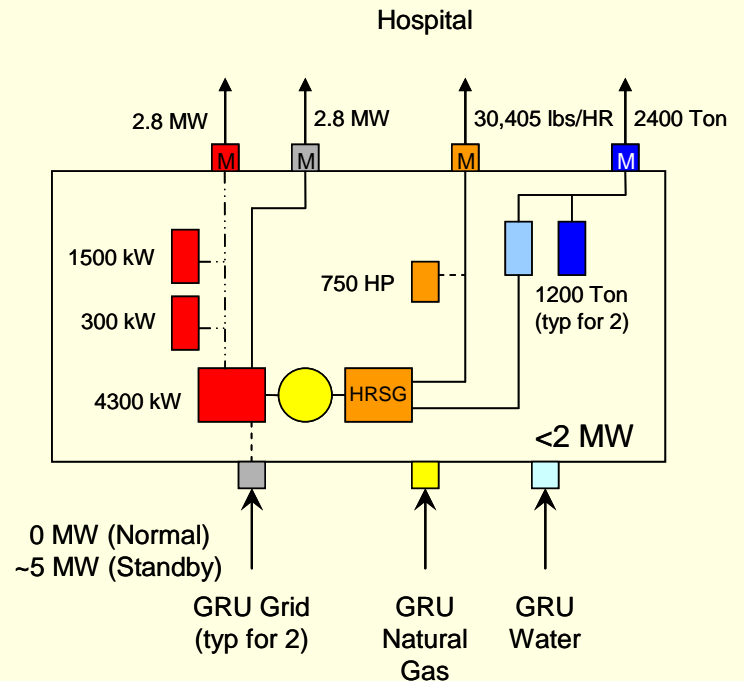

**CHP Alternative**

**Legend**

- Steam Turbine Chiller (1200 Ton)
- Diesel Engine Generator
- Electrical Chiller (1200 Ton)
- Natural Gas Boiler
- Natural Gas CT Generator (nominal 4 MW)
- M Hospital Meter



Shands Cancer Hospital  
GRU Energy Partner Team  
Proposed Central Plant Alternatives

# GRU South Energy Center

## ***Benefits...***

- Enhanced quality of power assuring smooth, continuous operation of clinical devices
- Two electrical feeds from different Substations in the surrounding power grid provide 200% electrical redundancy
- Emergency Generators provided for black start of combustion turbine generator and as a third back-up for Life Safety Systems
- As the Hospitals Energy Partner, GRU will finance, own, operate, and maintain the Energy Center reducing the hospital project capital costs

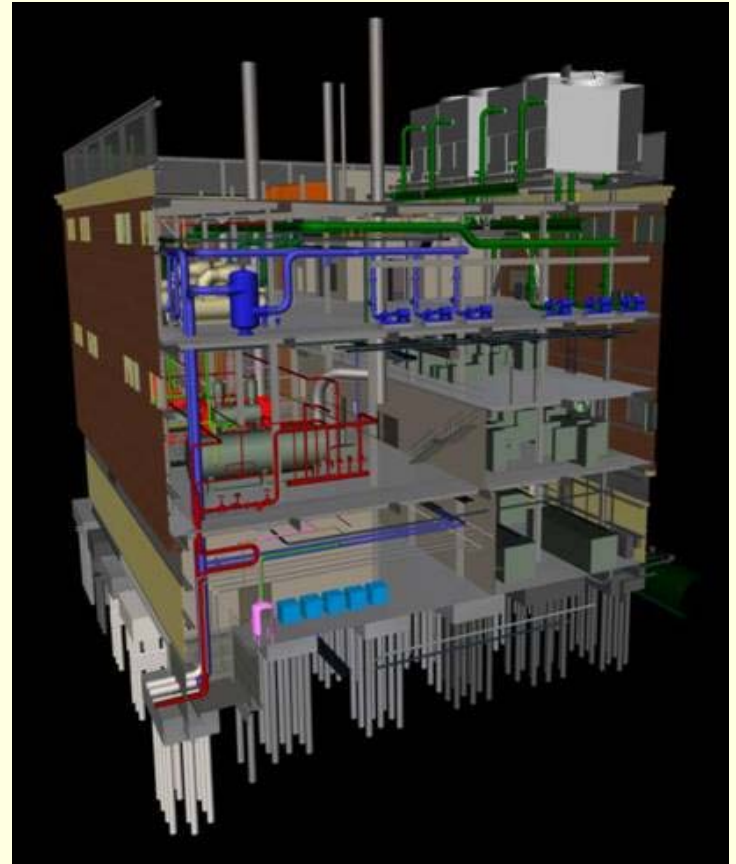

# CHP System Components

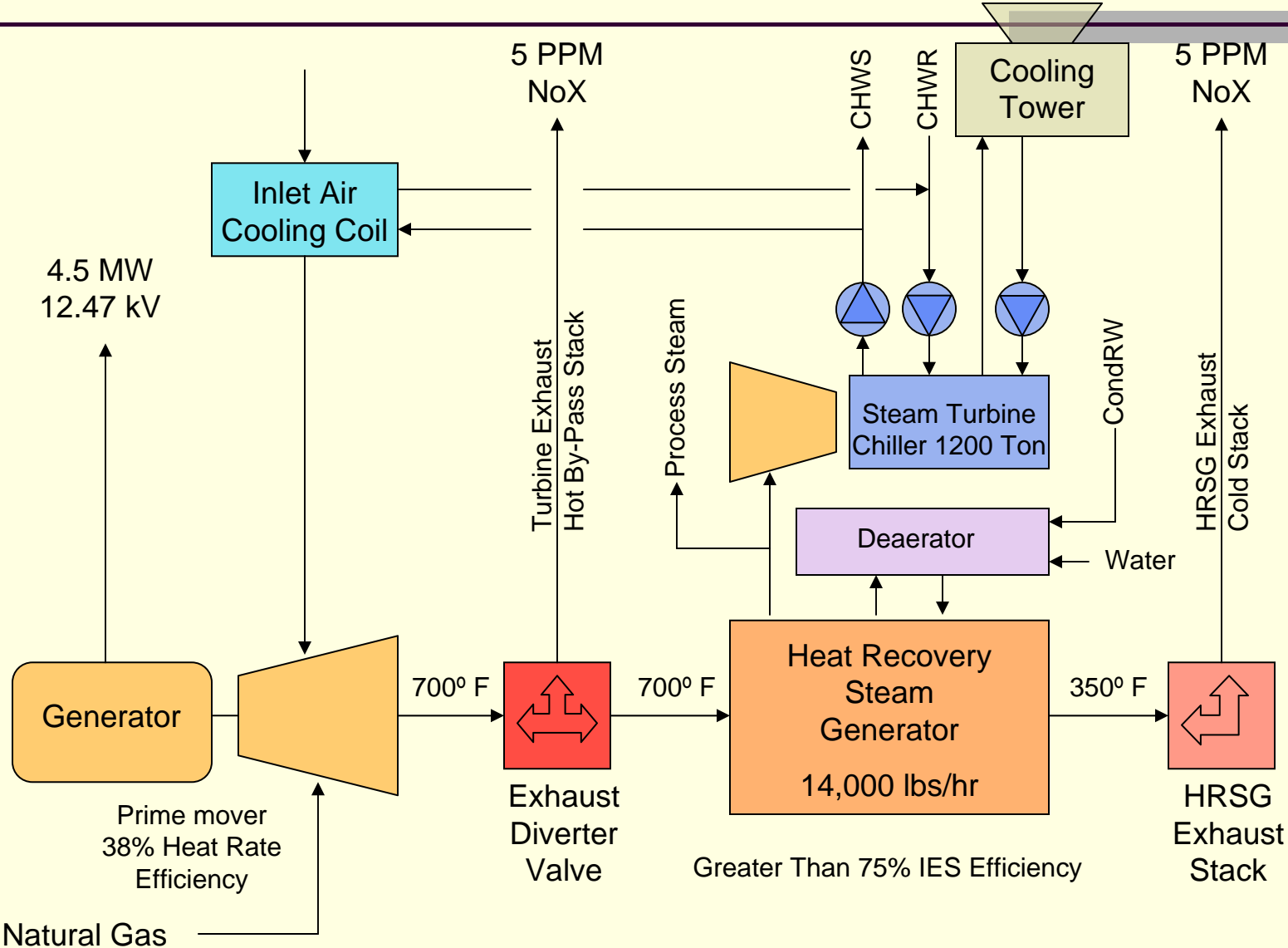

# Comparison Efficiency

## *Typical Power Delivery*

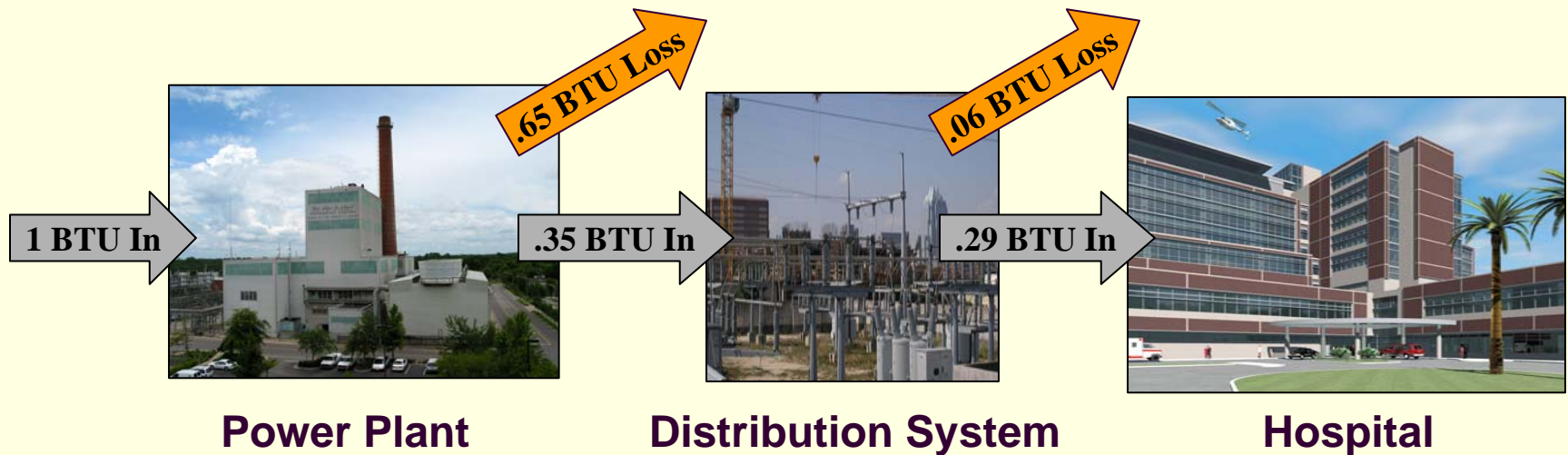

At a Coal Fired Power Station, about 35% of the primary fuel is converted into electricity; the remainder is lost “up the stack”. An additional 6% efficiency drop occurs in transmission to the site. Overall, at the Hospital’s meter, the result is roughly a *29% efficient primary fuel conversion to useful energy*.

# Comparison Efficiency

## *Cancer Hospital Power Delivery*

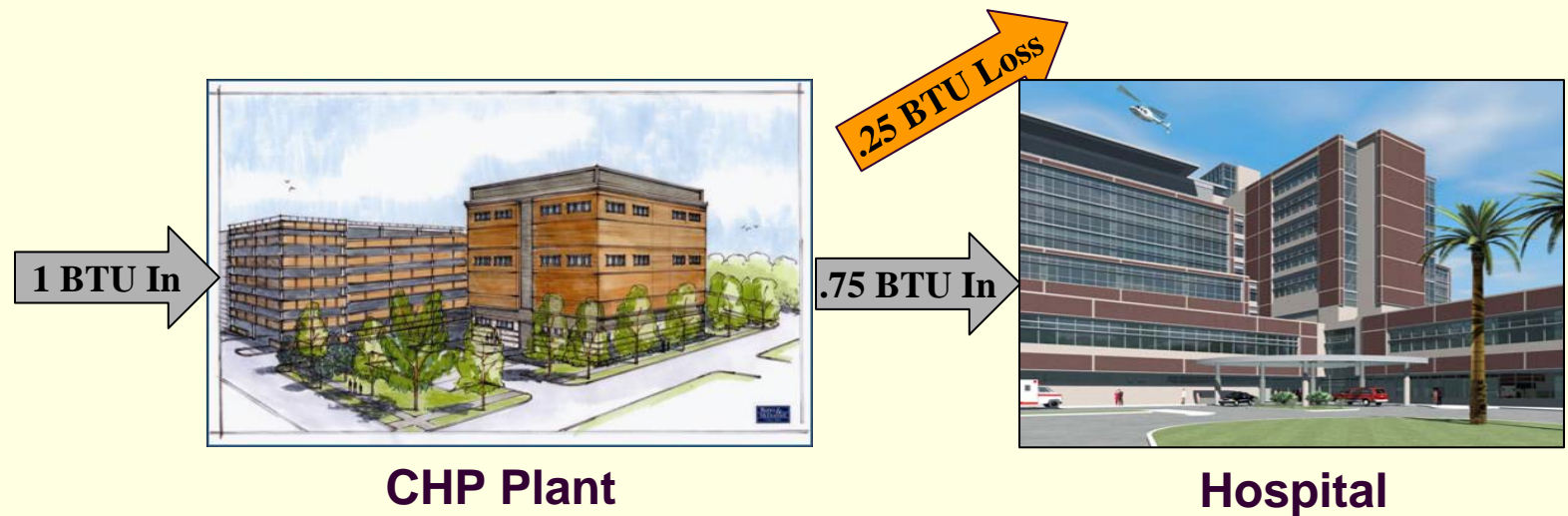

GRU's South CHP Energy Center at the Shands Cancer Hospital will be *75% efficient at primary fuel conversion to useful energy.*

This is a *46% savings in primary energy utilization* compared to the Typical Hospital Power Service Model.

# Energy Efficiency Comparison

---

- Fuel Conversion Efficiency

■ Utility @ 29%	1 kW=3,413 BTU	11,769 BTU
■ CHP @ 74%	1 kW=3,413 BTU	4,612 BTU

- Hospital Electric Load            31,950,038 kWh

- CUP =  $3.7602 \times 10^{11}$  BTU

- CHP =  $1.4735 \times 10^{11}$  BTU

- ***CUP fed from grid and serving the same load uses 255% more energy than CHP!***

# Environmental Comparison

## GRU's Fleet Central Power Plants



CO2 1,937 lbs/MWh  
SO2 8.44 lbs/MWh  
NOx 4.02 lbs/MWh

## GRU South Energy Center CHP Plant



CO2 615 lbs/MWh  
SO2 0.003 lbs/MWh  
NOx .043 lbs/MWh

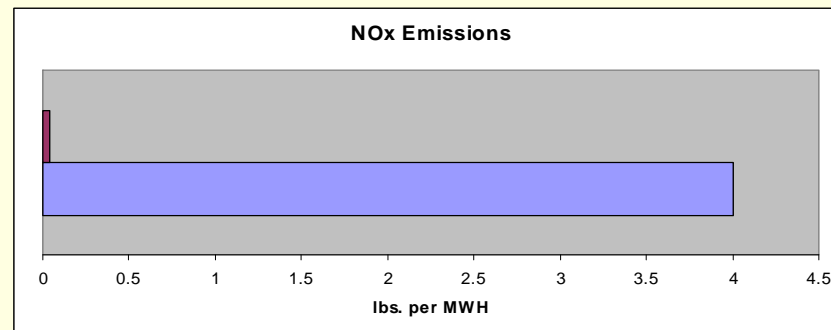
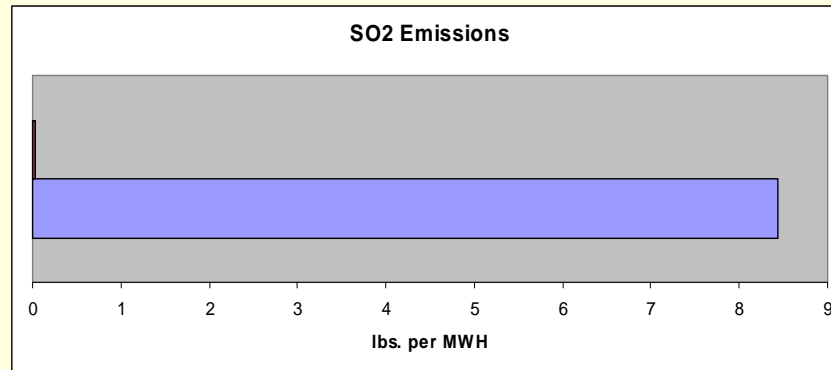
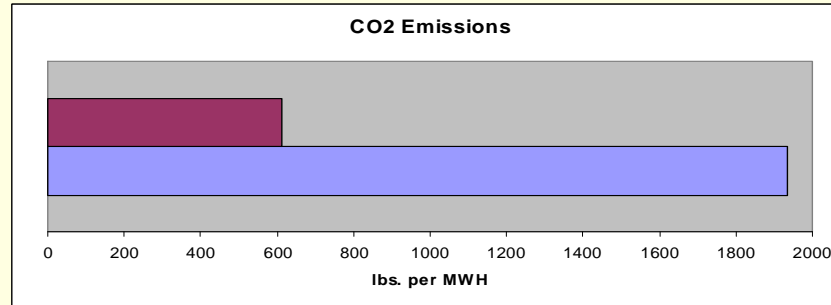

## CHP Results



The results generated by the CHP Emissions Calculator are intended for educational and outreach purposes only; it is not designed for use in developing emission inventories or preparing air permit applications.

Annual Emissions Analysis					
	CHP System	Displaced Electricity Production	Displaced Thermal Production	Emissions/Fuel Reduction	Percent Reduction
NOx (tons/year)	4.14	75.60	1.46	72.92	95%
SO2 (tons/year)	0.10	158.71	0.05	158.66	100%
CO2 (tons/year)	19,515	36,425	9,519	26,430	58%
Carbon (metric tons/year)	4,825	9,006	2,354	6,535	58%
Fuel Consumption (MMBtu/year)	333,585	357,290	162,725	186,431	36%
Equivalent Acres of Pine and Fir Forests				5,446	
Equivalent Passenger Vehicles				4,365	

**This CHP project will reduce emissions of Carbon Dioxide (CO2) by 26,430 tons per year**

**This is equal to 6,535 metric tons of carbon equivalent (MTCE) per year**

**This reduction is equal to the annual carbon stored by 5,446 acres of pine and fir forests**



**OR**

**This reduction is equal to the carbon emissions of 4,365 passenger vehicles per year**



# Summary

---

## ■ **Features:**

- One of the first grid independent hospitals in the State of Florida with the ability to serve 100% of the hospitals electric and thermal energy needs in the event of an grid outage.
- One the first on-site energy centers in State of Florida to integrate Combined Heat & Power.
- The first CHP energy center where the local municipal partnered with the local community hospital using an innovative open book 50 year contract to provide all of the hospitals energy needs.

## ■ **Benefits:**

- Combined Heat and Power
  - Better quality normal power
  - More capacity for essential power requirements during a grid outage
  - Higher efficiency that traditional central generation plants
  - Lower nitrous oxide (NOx), carbon dioxide (CO), and Sulfur Oxide (SO2) emissions than central generation plants.
  - More reliable because generation in on-site and not effected by distribution systems
- District Cooling
  - Improved efficiency through economy of scale
  - Energy company focused on energy delivery and reliability

# Contact Information

---

- Ed Mardiat: [emardiat@burnsmcd.com](mailto:emardiat@burnsmcd.com)
- Rod Schwass: [rschwass@burnsmcd.com](mailto:rschwass@burnsmcd.com)