

**Scientific, Technical, Research, Engineering  
and Modeling Support (STREAMS)  
Final Report**

**State of the Science  
Literature Review:  
Nano Titanium Dioxide  
Environmental Matters**



# **Scientific, Technical, Research, Engineering and Modeling Support (STREAMS) Final Report**

**Contract No. EP-C-05-059**

**Task Order No. 94**

## **State of the Science Literature Review: Nano Titanium Dioxide Environmental Matters**

Prepared for

Katrina Varner, Task Order Manager  
U.S. Environmental Protection Agency  
National Exposure Research Laboratory  
Environmental Sciences Division  
Las Vegas, NV 89119

Prepared by

Eastern Research Group  
10200 Alliance Road, Suite 190  
Cincinnati, OH 45242

Although this work was reviewed by EPA and approved for publication, it may not necessarily reflect official Agency policy. Mention of trade names and commercial products does not constitute endorsement or recommendation for use.

U.S. Environmental Protection Agency  
Office of Research and Development  
Washington, DC 20460



---

## CONTENTS

	<b>Page</b>
1. EXECUTIVE SUMMARY.....	1-1
2. PURPOSE OF REPORT.....	2-1
3. LITERATURE AND GRAY INFORMATION SEARCH STRATEGY.....	3-1
3.1 Dialog® Search Strategy and Results.....	3-1
3.1.1 Dialog® Search Parameters.....	3-2
3.1.2 Dialog® Search Procedure and Results.....	3-4
3.2 Targeted Search of Databases, Journals, and Conference Proceedings and Results.....	3-7
3.2.1 Nano-specific Journals.....	3-7
3.2.2 Conference Proceedings.....	3-7
3.2.3 Databases of Nanotechnology Research.....	3-8
3.3 Contacts with Industry and Academic Experts.....	3-9
3.4 Results and Areas for Future Work.....	3-10
4. BACKGROUND OF TITANIUM DIOXIDE AND ITS USE.....	4-1
4.1 Titanium Dioxide Physical and Chemical Properties.....	4-1
4.2 Overview of Applications of Titanium Dioxide.....	4-2
4.2.1 Historical Applications of Titanium Dioxide.....	4-2
4.2.2 Applications of Nanoscale Titanium Dioxide.....	4-4
5. LIFE CYCLE OVERVIEW.....	5-1
5.1 Manufacture of Nano-TiO <sub>2</sub> .....	5-3
5.1.1 Manufacture of Nano-TiO <sub>2</sub> for Sunscreens.....	5-10
5.1.2 Manufacture of Nano-TiO <sub>2</sub> for Other UV Stabilizers.....	5-11
5.1.3 Manufacture of Nano-TiO <sub>2</sub> for Photocatalysts.....	5-11
5.2 Processing of Nano-TiO <sub>2</sub> .....	5-11
5.2.1 Processing of Nano-TiO <sub>2</sub> for Sunscreens.....	5-12
5.2.2 Processing of Nano-TiO <sub>2</sub> for Other UV Stabilizers.....	5-12
5.2.3 Processing of Nano-TiO <sub>2</sub> for Photocatalysts.....	5-13
5.3 Use of Nano-TiO <sub>2</sub> .....	5-13
5.3.1 Use of Nano-TiO <sub>2</sub> in Sunscreens.....	5-13
5.3.2 Use of Nano-TiO <sub>2</sub> as Other UV Stabilizers.....	5-14
5.3.3 Use of Nano-TiO <sub>2</sub> as Photocatalysts.....	5-14
5.4 End of Life.....	5-15
5.4.1 End-of-Life of Sunscreens.....	5-15
5.4.2 End-of-Life of Other UV Stabilizers.....	5-16
5.4.3 End-of-Life of Photocatalysts.....	5-16
6. EXPOSURE PATHWAYS.....	6-1
6.1 Exposure Sources.....	6-1
6.1.1 Manufacturing.....	6-1
6.1.2 Processing.....	6-3
6.1.3 Use.....	6-4
6.1.4 End-of-Life of Consumer Products.....	6-6

---

**CONTENTS (Continued)**

	<b>Page</b>
6.2	Transport Mechanisms..... 6-8
6.2.1	Transport Mechanisms in Surface Water..... 6-8
6.2.2	Transport Mechanisms in Groundwater..... 6-9
6.2.3	Transport Mechanisms in Soil ..... 6-10
6.2.4	Transport Mechanisms in Air ..... 6-11
6.3	Points and Routes of Exposure ..... 6-11
6.3.1	Dermal Exposures ..... 6-11
6.3.2	Inhalation Exposures..... 6-11
6.3.3	Ingestion Exposures ..... 6-11
6.4	Receptor Populations ..... 6-12
7.	TOXIC EFFECTS..... 7-1
7.1	Health Effects..... 7-1
7.1.1	Inhalation Studies or Effects ..... 7-3
7.1.2	Dermal Studies or Effects ..... 7-4
7.1.3	Oral Administration Studies or Effects ..... 7-4
7.2	Ecological Effects ..... 7-4
7.2.1	Aquatic Life ..... 7-4
7.2.2	Terrestrial Life ..... 7-5
7.3	Additional Literature..... 7-5
8.	SAMPLING AND ANALYSIS ..... 8-1
8.1	Sampling Techniques..... 8-1
8.1.1	Sampling Techniques Suited for Surface Waters ..... 8-2
8.1.2	Sampling Techniques Suited for Sediments ..... 8-2
8.1.3	Sampling Techniques Suited for Soil ..... 8-3
8.1.4	Sampling Techniques Suited for Groundwater..... 8-3
8.1.5	Sampling Techniques Suited for Air..... 8-3
8.2	Analytical Techniques ..... 8-3
8.2.1	Analytical Techniques for Size Fractionation..... 8-4
8.2.2	Analytical Techniques for Size Distribution..... 8-5
8.2.3	Analytical Techniques for Surface Area..... 8-8
8.2.4	Analytical Techniques for Chemical Analysis ..... 8-8
8.2.5	Analytical Techniques for Direct Visualization ..... 8-8
8.2.6	Analytical Techniques for Mineral Phase/Internal Structure..... 8-9
9.	REFERENCES ..... 9-1
APPENDIX A	DIALOG® SEARCH RESULTS
A-1	Potentially Applicable Titles for Production, Use, Distribution, and Disposal of Nano-TiO <sub>2</sub>
A-2	Potentially Applicable Titles for Exposure Pathways and Transport Mechanisms
A-3	Potentially Applicable Titles for Toxicological and Ecological Effects of Nano-TiO <sub>2</sub>
A-4	Potentially Applicable Titles for Sampling and Analysis of Nano-TiO <sub>2</sub> in the Environment

---

**CONTENTS (Continued)**

**Page**

A-5 Non-applicable Titles

---

## LIST OF TABLES

	<b>Page</b>
Table 3-1. List of Databases Included for DIALOG® Search and Results .....	3-6
Table 3-2. Preliminary List of Journals to Review for Search Strategy #2 .....	3-7
Table 3-3. List of Targeted Conference Proceedings Reviewed for Search Strategy #2 .....	3-8
Table 3-4. List of Contacted Researchers .....	3-10
Table 3-5. Articles Reviewed for Literature Search .....	3-12
Table 4-1. Top Global Producers of TiO <sub>2</sub> Mineral Ores .....	4-1
Table 4-2. Annual Volumes of Total TiO <sub>2</sub> in the United States .....	4-3
Table 5-1. Summary of Consumer Product Categories that Use Nano-TiO <sub>2</sub> from the Project on Emerging Nanotechnologies Consumer Products Inventory.....	5-2
Table 5-2. Estimated Annual Volumes of Nano-TiO <sub>2</sub> Globally and in the United States.....	5-7
Table 5-3. Nano-TiO <sub>2</sub> Manufacturers, Facilities, and Identified Products .....	5-8
Table 5-4. Nano-TiO <sub>2</sub> Processors, Facilities, and Identified Products .....	5-12
Table 6-1. Summary of Process Releases of Nano-TiO <sub>2</sub> to Environmental Media During Manufacturing.....	6-2
Table 6-2. Summary of Process Releases of Nano-TiO <sub>2</sub> to Environmental Media.....	6-4
Table 7-1. Summary of Toxicity Effects .....	7-2
Table 7-2. Summary of Ecotoxicity Effects .....	7-4
Table 7-3. Additional Titles Discussing nano-TiO <sub>2</sub> Ecological and Toxicological Effects .....	7-6

---

**LIST OF FIGURES**

	<b>Page</b>
Figure 3-1. General DIALOG® Literature Search Flow Chart.....	3-4
Figure 5-1. Nano-TiO <sub>2</sub> Manufacturing Process Diagram According to the DuPont Patent.....	5-5

---

## 1. EXECUTIVE SUMMARY

The purpose of this report is to compile and summarize currently-available information pertaining to the manufacturing, processing, use, and end-of-life for nanoscale titanium dioxide (nano-TiO<sub>2</sub>). The focus of the report is to identify, summarize, and present information; rather than to perform a critical evaluation of the results. The intent is to provide this information to the scientific community such that it can be used to complete an exposure assessment and evaluate the human health and toxicity of nano-TiO<sub>2</sub> throughout its life cycle as it is manufactured and introduced into the domestic market place and subsequently the environment.

A formal literature search was conducted using the Dialog® search engine and three sets of keywords. The sets were designed to capture published information pertaining to:

- The manufacturing, processing, and industrial use of nano-TiO<sub>2</sub>;
- Exposure pathways, transport mechanisms and human health effects; and
- Sampling techniques for the environmental media.

This literature search resulted in identification of over 1,000 articles from 32 databases. Citations for all search results are presented in tables and appendices, and selected articles were thoroughly reviewed and used to summarize results as presented in the report.

Because the field of nanotechnology is advancing so rapidly, applicable information is not always available in published and peer reviewed scientific journals. Therefore, to supplement the literature search, “gray” literature and information was also solicited and identified. This included:

- A review of selected recent conferences and symposia;
- A review of selected journals not included in the Dialog® search engine; and,
- Personal contacts with expert research scientists and industrial stakeholders.

Information from the literature review and the supplemental strategy to identify gray information was summarized to fully characterize the known information pertaining to nano-TiO<sub>2</sub> and its life cycle.

Not only are new studies being initiated almost daily; but, so are nano-specific conferences and symposia. Even new, nano-specific journals are being developed every year. Therefore, the reader should recognize this document (and the search for information) captures the breath of known data as of March 2010. Future work may provide information to supplement or supersede the summaries described within this report.

Although a significant amount of information exists, there are areas for which data is sparse or lacking entirely. Ongoing studies may provide information to fill some of these gaps and additional research is necessary to fill others. Primary data gaps include:

- Specific information pertaining to the production volume of nano-TiO<sub>2</sub> (the specific quantity domestically manufactured);

- 
- A comprehensive list of domestic manufacturers, processors, and industrial users (and corresponding throughput of nano-TiO<sub>2</sub> at these facilities);
  - Specific unit operations utilized by industrial sites;
  - Agreed-upon methods to characterize nanomaterials in general, leading to standardized sampling and analysis methods (for nano-TiO<sub>2</sub> and all nanomaterials);
  - A better understanding of the fate & transport of nano-TiO<sub>2</sub> after release into the environment; and,
  - A thorough review of human health & toxicological data.

---

## 2. PURPOSE OF REPORT

The rapidly advancing field of nanotechnology offers potential benefits to almost all industries and products. According to the Woodrow Wilson International Center for Scholars' Project on Emerging Nanotechnology, nanomaterials are currently being used in over 1,000 consumer products. Metal oxides such as titanium dioxide (TiO<sub>2</sub>) are some of the many materials that are manufactured and used as engineered nanomaterials in increasing quantities. TiO<sub>2</sub> has been used for decades in consumer products such as sunscreens at the micro- and macroscale. Recently, scientific breakthroughs now allow TiO<sub>2</sub> to be economically produced at the nanoscale and incorporated into a variety of consumer products. This increased use of nano-TiO<sub>2</sub> has raised concerns regarding the potential exposures and subsequent human health and environmental effects.

EPA has recognized the importance of nanomaterial research and development, as well as the need to thoroughly evaluate potential concerns to human health and the environment. EPA's *Nanotechnology White Paper* states, "While [EPA] is interested in researching and developing the possible benefits of nanotechnology, EPA also has the obligation and mandate to protect human health and safeguard the environment ... [The *White Paper's* purpose is to] ... inform EPA management of the science needs associated with nanotechnology, to support related EPA program office needs, and to communicate these nanotechnology science issues to stakeholders and the public." Subsequent to release of the *Nanotechnology White Paper*, EPA's Office of Research and Development (ORD) developed an overarching research strategy to evaluate nanomaterials on a number of fronts. This strategy is presented in *ORD's National Research Strategy*, the purpose of which is, "... to guide the EPA's Office of Research and Development (ORD) programs in nanomaterial research ... and incorporate these research activities into its multi-year planning process." Development of this report is one part of ORD's overall strategy, to identify the state-of-the-science surrounding nano-TiO<sub>2</sub>.

Specifically, the purpose of this report is to assist in the assessment of potential environmental and human health risks associated with nano-TiO<sub>2</sub> by conducting a state-of-the-science literature review to compile known information regarding the production, use, distribution and disposal of nano-TiO<sub>2</sub> through its entire life cycle. Because the field of nanotechnology is advancing so rapidly, applicable information is not always available in published and peer reviewed scientific journals. Therefore, to complete this review, information identified from the formal literature search was supplemented with gray information (e.g., conference proceedings and personal communications with research scientists).

This document presents the results of the state-of-the-science review:

- Section 3 (Literature and Gray Information Search Strategy) provides a thorough description of the search strategy that was used to identify over 1,000 journal articles and to review gray sources of information (Appendix A includes detailed search results);
- Section 4 (Background of Titanium Dioxide and its Use) provides background information pertaining to TiO<sub>2</sub>, including the physical and chemical properties associated with macroscale and nanoscale forms that make this chemical appealing for various uses;
- Section 5 (Life Cycle Overview) identifies known uses of nano-TiO<sub>2</sub> and provides additional information pertaining to the industrial supply chain, end use, and end of life;

- 
- Section 6 (Exposure Pathways) identifies expected sources of release, exposure pathways and routes, and potential receptors;
  - Section 7 (Health Effects); presents a summary of human health and toxicological research that has been conducted for nano-TiO<sub>2</sub>; and,
  - Section 8 (Sampling and Analysis) discusses sampling analysis methods and techniques that are, or can be, used to characterize nano-TiO<sub>2</sub> (focusing on environmental media and associated sampling)

As previously noted, the field of nanotechnology is advancing at such a rapid pace that new studies are being initiated almost daily and results are discussed at frequent nano-specific conferences and symposia. Even new, nano-specific journals are being developed every year. Therefore, the reader should recognize this document (and the search for information) captures the breadth of known data as of March 2010. Future work may provide information to supplement or supersede the summaries described within this report.

It should also be noted that the intent of this state-of-the-science literature review is to provide a summary of known information. The intent is not to provide a critical evaluation of the data such as in a critical literature review. A critical literature review (particularly pertaining to the gray information) is out of scope of this report. Additionally, although this report provides a review of the life cycle of nano-TiO<sub>2</sub>, a life-cycle assessment (LCA) and its components are out of scope. An LCA begins with a life-cycle inventory (LCI), which involves an accounting of the environmental inputs and outputs, or inventory flows, for a product system over its entire life cycle. An LCI is very comprehensive but only provides the foundation for a full LCA. In addition to an LCI, an LCA includes an LCIA (life-cycle impact assessment). An LCIA categorizes the inventory flows identified by an LCI into various types of ecological and human health impacts to provide a complete evaluation of environmental risk. Inventories and assessments such as these include analyses of environmental impacts that are not directly related to release and exposure of the chemical of concern (nano-TiO<sub>2</sub> in this case); such as energy and water use as well as greenhouse gas emissions from all life cycle stages.

In addition to this state-of-the-science literature review, EPA is completing two complimentary studies pertaining to nano-TiO<sub>2</sub>:

- A case study of nano-TiO<sub>2</sub> specific for sunscreen and water treatment applications that follows the comprehensive environmental assessment (CEA) approach for the purpose of identifying and prioritizing research needs, conducted by EPA's National Center for Environmental Assessment (NCEA)<sup>1</sup>; and
- A comparative LCI of sunscreens that use nano-TiO<sub>2</sub> and organic UV blockers, conducted by EPA's National Risk Management Research Laboratory (NRMRL).

Each of these three reports evaluate different aspects and environmental concerns of the life cycle of TiO<sub>2</sub>, identifying areas for additional research, and building a foundation for a future risk assessment. This state-of-the-science literature review provides a summary of all identified applications of nano-TiO<sub>2</sub> and their respective life cycles. On the other hand, the NCEA case study and NRMRL LCI both focus on specific applications of nano-TiO<sub>2</sub> and provide further details of these applications.

---

Although the complete characterization of environmental risk is out of scope, Section 7 of this report includes a summary of the literature search pertaining to human health and toxicological concerns of nano-TiO<sub>2</sub> for completeness; noting that a thorough review of this topic was not the primary focus. A more complete evaluation of toxic effects is anticipated as part of the case study for nano-TiO<sub>2</sub> that is being conducted by NCEA.<sup>1</sup> The final draft is expected to be released in the late summer of 2010.

---

### 3. LITERATURE AND GRAY INFORMATION SEARCH STRATEGY

A detailed informational search to support EPA's state-of-the-science review for nanoscale titanium dioxide life cycle was conducted. The approach to this search included three separate, but parallel, strategies described in the following subsections:

- Section 3.1 describes the collection of available published literature using the Dialog® search engine (Search Strategy #1);
- Section 3.2 describes the review of information from targeted sources, such as nano-specific journals, conference proceedings, grants databases, and research databases (Search Strategy #2); and
- Section 3.3 describes contacts with industry and academic experts (Search Strategy #3).

The approach generally included the following steps:

1. Conduct an initial review focused on targeted sources;
2. Evaluate information collected during the initial review and identify topic areas that require additional information; and
3. Review additional sources to identify articles, presentations, or research that may provide appropriate information.

Initial efforts focused on reviewing a targeted list of journal articles under Search Strategy #2 as well as contacting industry experts under Search Strategy #3. Additional resources were also identified using the Dialog® search results, a list of nano-specific journals, conference proceedings, grant databases, and research databases.

#### 3.1 Dialog® Search Strategy and Results

The Dialog® search produced four lists of titles of potentially-relevant articles

1. Thirty-eight titles pertaining to the production, use, distribution, and disposal of nano-TiO<sub>2</sub> (Appendix A-1);
2. Seven titles pertaining to exposure pathways and transport mechanisms (Appendix A-2);
3. Forty-three titles pertaining to the toxicological and ecological effects of nano-TiO<sub>2</sub> (Appendix A-3); and
4. Eight titles pertaining to characterization and sampling techniques for nano-TiO<sub>2</sub> in the environment (Appendix A-4).

This subsection describes the parameters that were specified for the Dialog® search, the search procedure and results, along with next steps.

---

### 3.1.1 Dialog® Search Parameters

The parameters that were specified for the DIALOG search include keywords, publication dates, languages, and the list of databases to be included in the search.

Keywords: Keywords were searched in the “title,” “abstract,” and “descriptor” fields.

#### *Primary Keywords*

“nano\*” and “titanium dioxide” or “titania” or “TiO<sub>2</sub>”

These terms were identified as keywords, assuming they would capture the following words of interest:

Nanomaterial, nanoparticle, nanoscale; titanium dioxide; titania; or TiO<sub>2</sub>.

#### *Secondary Keywords:*

Set One: Production, use, distribution, and disposal of nano-TiO<sub>2</sub>

“manufac\*” or “process\*” or “dispos\*” or “market\*” or “application” or “production”

These terms were identified as keywords, assuming they would capture the following words of interest:

Manufactured, manufacturing, process, processing, disposal, disposed, market, application, or production.

The terms synthesis and preparation were omitted from the search parameters in order to exclude literature results specific to lab-scale synthesis and characterization.

Set Two: Exposure pathways, transport mechanisms, and human health effects

“ecologic\*” or “environment\*” or “expos\*” or “human” or “popul\*”

<AND>

“analy\*” or “sampl\*” or “stud\*” or “expos\*” or “toxic\*” or “health\*” or “anthropogenic\*” or “manufactur\*” or “detect\*” or “monitor\*” or “transport” or “migrat\*” or “route\*” or “source” or “dose\*” or “fate” or “geograph\*” or “assess\*”

---

These terms were identified as keywords, assuming they would capture the following words of interest:

Ecologic, ecological; environment, environmental; exposed, exposure; human; population; analysis, analytical; sample, sampling; study, studies; toxic, toxicity, toxicological; health; anthropogenic; manufacture, manufacturing; detect, detection; monitor, monitoring; transport; migrate, migration; routes; sources; doses; fate; geography, geographic, geographical; assessed, or assessment.

Set Three: Sampling and analytical techniques

“soil” or “air” or “water” or “sediment” or “environment\*” or “ground\*” or “expos\*” or “aqueous”

<AND>

“analy\*” or “sampl\*” or “remediat\*” or “contamina\*” or “characteriz\*” or “anthropogenic\*” or “manufactur\*” or “detect\*” or “monitor\*” or “separat\*” or “quant\*” or “measure\*”

These terms were identified as keywords, assuming they would capture the following words of interest:

Soil; air; water; sediment; environment, environmental; ground, groundwater; expose, exposure; aqueous; analysis, analytical; sample, sampling; remediate, remediation; contaminant, contamination; characterize, characterization; anthropogenic; manufactured, manufacturing; detect, detection; monitor, monitoring; separate, separation; quantify, quantitative; measured, or measurements.

Publication Dates: The Dialog® search included all articles published in the year 2000 and later.

Language: Only articles published in English were evaluated.

Databases: Thirty two databases were included in the Dialog® search (refer to Table 3-1 at the end of this section). These were identified by evaluating the Dialog® subject guides in “Science - Energy & Environment” and “Science - Engineering & Technology.”

---

### 3.1.2 Dialog® Search Procedure and Results

Figure 3-1 shows the general decision-making steps via a flowchart for the Dialog® literature search.

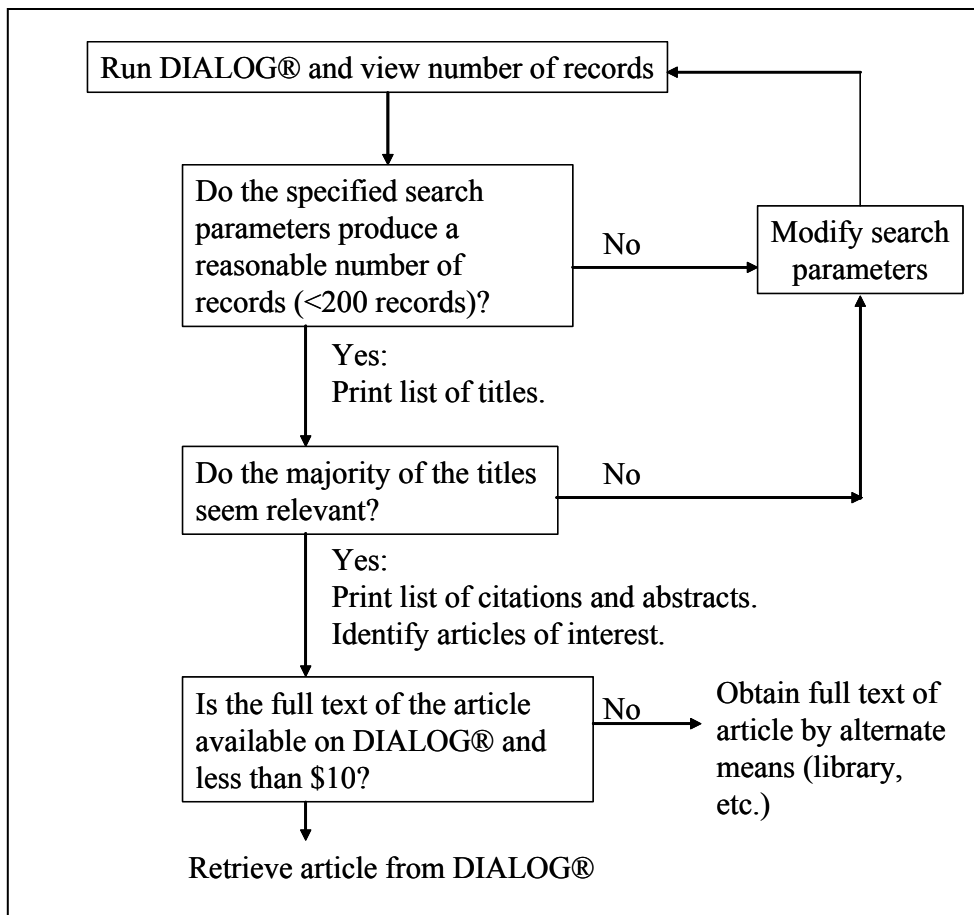

**Figure 3-1. General DIALOG® Literature Search Flow Chart**

Specific notes discussing the search process and results are presented below.

1. Dialog® was initially run using the specified parameters described in the previous section. The results of this run produced 2,028 unique records in the following literature search areas:
  - Set 1: Production, use, distribution, and disposal – 1,163 records
  - Set 2: Exposure pathways, transport mechanisms, and toxicological and ecological effects – 298 records
  - Set 3: Sampling and analytical techniques – 567 records
2. The production search was then modified to exclude records containing the words “synthesis” and “preparation” so that results specific to laboratory synthesis and

---

characterization would be omitted. However, the Dialog® output continued to produce more than 1,000 records.

3. The sampling search (Set 3) was then modified to return titles published after 2006. This narrowed the Dialog® output to 224 titles. Literature published between 2000 and 2006 was retrieved from search results from a similar Dialog® search that ERG had conducted in 2007 for sampling and analysis techniques of nanomaterials. This provided 37 additional titles.
4. It was determined that the resulting list of 1,351 records could be reviewed manually within a reasonable timeframe. An initial, screening-level review of these records was conducted to identify titles associated with production, exposure, ecological and toxicological effects, and sampling that appeared relevant and warranted acquisition and further review. This screening-level review process (further detailed below) yielded 96 potentially-relevant titles. The remaining 1,253 titles were subsequently dropped from further review. For reference and future investigation, these titles are provided in Appendix A-5.
5. During the screening-level review, relevance was based on a brief review of titles and abstracts. For example, literature titles such as “Tibet develops nanometre titanium dioxide” and “Sol-Gel Synthesis and Characterization of Neodymium-Ion Doped Nanostructured Titania Thin Films” were not expected to discuss nano-TiO<sub>2</sub> aspects within the scope of this report. For the latter title, a quick review of the title’s abstract confirmed that the article was specific to laboratory synthesis and characterization which, as discussed in Section 3.1.1, is not desired information for this report. Appendix A-5 lists approximately 1,200 titles that were not expected to contain applicable information. Examples of keywords and phrases that were commonly found in the unrelated titles include the following:
  - Lab scale production, synthesis, characterization, or performance evaluation of materials comprised of or containing nanoscale TiO<sub>2</sub>
  - Experimental studies dedicated to the theoretical understanding of the physical and chemical properties of nano-TiO<sub>2</sub> under specific conditions (e.g., photocatalytic reactions)
6. Next, the 96 potentially-relevant titles were retrieved and reviewed (see Appendices A-1 through A-4 for complete lists of titles). The type of articles that were obtained and evaluated for this report include:
  - Production, use, distribution, and disposal – 38 articles
  - Exposure pathways, transport mechanisms – 7 articles
  - Human health – 43 articles
  - Sampling and analytical techniques – 8 articles

Table 3-1 lists databases that were included in the Dialog® search and the number of hits per database for the initial search. Articles cited in this report are presented in Table 3-5 at the end of this section.

**Table 3-1. List of Databases Included for DIALOG® Search and Results**

Database Number	Database Name	Hits Pertaining to Production	Hits Pertaining to Exposure	Hits Pertaining to Toxicity	Hits Pertaining to Sampling and Analysis
6	NTIS	0	0	0	0
9	Business & Industry®	11	0	0	0
19	Chem.Industry Notes	0	0	0	0
31	World Surface Coatings Abs	0	1	9	0
32	METADEX	3	0	4	0
34	SciSearch(R) Cited Ref Sci	9	3	23	6
35	Dissertation Abs Online	8	0	0	0
36	MetalBase	1	0	0	0
40	Enviroline®	0	0	0	0
41	Pollution Abstracts	0	0	0	0
57	Electronics & Communications Abstracts	0	0	0	0
60	ANTE: Abstracts in New Tech & Engineer	0	0	0	0
64	Environmental Engineering Abstracts	0	0	0	0
65	Inside Conferences	1	2	1	0
73	EMBASE	1	0	2	0
76	Environmental Sciences	1	0	0	1
95	TEME-Technology & Management	0	0	0	0
99	Wilson Appl. Sci & Tech Abs	0	0	0	0
103	Energy SciTec	0	0	0	0
110	WasteInfo	0	0	0	0
149	TGG Health&Wellness DB(SM)	1	0	2	0
185	Zoological Record Online®	0	0	1	0
245	WATERNET™	0	0	0	0
293	Engineered Materials Abstracts	0	0	0	1
315	ChemEng & Biotec Abs	0	0	0	0
317	Chemical Safety NewsBase	0	1	1	0
322	Polymer Online	1	0	0	0
323	RAPRA Polymer Library	0	0	0	0
335	Ceramic Abstracts/World Ceramics Abstracts	0	0	0	0
369	New Scientist	0	0	0	0
370	Science	0	0	0	0
469	Gale DB of Publ.& Broad.Media	0	0	0	0
636	Gale Group Newsletter DB(TM)	1	0	0	0
	<b>Total</b>	<b>38</b>	<b>7</b>	<b>43</b>	<b>8</b>

Database Number – a unique numeric identifier assigned to each Dialog® database.  
 For more information on these databases, see <http://library.dialog.com/bluesheets/>.

---

## 3.2 Targeted Search of Databases, Journals, and Conference Proceedings and Results

In addition to the Dialog® titles identified during Search Strategy #1, additional sources were identified during Search Strategy #2 (review of targeted sources). The targeted sources in Search Strategy #2 included:

- Nano-specific journals;
- Conference proceedings;
- Databases of nanotechnology research; and

### 3.2.1 Nano-specific Journals

As a first step, 16 journals that were recommended by industry and academic experts as good sources of information to include in the state-of-the-science review of nanoscale TiO<sub>2</sub> were reviewed and potentially applicable articles were obtained. Additional articles were added to the resulting list based on personal contacts with industry experts (described in Section 3.3) and from the Dialog® literature search (described in Section 3.1).

Table 3-2 presents the preliminary list of 16 journals that were initially targeted for this review. Based on a preliminary review, two of these (the Nanorisk Newsletter and NanoNow) were determined to be too broad in scope and were therefore not obtained or evaluated for further review.

**Table 3-2. Preliminary List of Journals to Review for Search Strategy #2**

Nano-Specific Journals			
Environmental Pollution	Nanorisk Newsletter*	Nanotechnology	NanoNow*
Journal of Nano Research	Journal of Nanobiotechnology	Particle and Fibre Toxicology	Nanotoxicology
Journal of Environmental Monitoring	Journal of Nanoparticle Research	Journal of Environmental Engineering	International Journal of Nanoscience (IJN)
Environmental Monitoring and Assessment	Nano Letters (American Chemical Society)	Journal of Nanoscience and Nanotechnology	Fullerenes, Nanotubes and Carbon Nanostructures

\*Journal was not included in literature review.

### 3.2.2 Conference Proceedings

Table 3-3 identifies the initial conference proceedings that were targeted for review under Search Strategy #2.

---

**Table 3-3. List of Targeted Conference Proceedings Reviewed for Search Strategy #2**

<b>Nano-Specific Conferences</b>	
NNI Workshop: Nanomaterials and Human Health & Instrumentation, Metrology, and Analytical Methods. Arlington, VA. November 17-18, 2009	AIChE 2009 Annual Meeting. Nashville, TN. November 8-13, 2009.
4 <sup>th</sup> International Conference on the Environmental Effects of Nanoparticles and Nanomaterials. Vienna, Austria. September 6-9, 2009.	World Congress of Chemical Engineering. Montreal, Canada. August 23-27, 2009.
4 <sup>th</sup> International Conference on Nanotechnology – Occupational and Environmental Health. Helsinki, Finland. August 26-29, 2009.	OECD Conference on Potential Environmental Benefits of Nanotechnology: Fostering Safe Innovation-Led Growth. Paris, France. July 15-17, 2009.
International Conference on the Environmental Implications and Applications of Nanotechnology. Amherst, MA. June 09-11, 2009.	Nanotechnology Health & Safety Forum (NHSF). Seattle, WA. June 8-9, 2009.
International Conference on the Environmental Implications of NanoTechnology	NNI Workshop: Nanomaterials and Human Health & Instrumentation, Metrology, and Analytical Methods. Arlington, VA. October 6-7, 2009.
Proceedings of the Interagency Workshop on the Environmental Implications of Nanotechnology. Washington, DC. September 5-7, 2007.	

The DIALOG® search identified two additional conferences that were also reviewed for applicable papers or presentations. These were:

- 37th Annual Meeting of the European Teratology Society. Arles, France. September 6-10, 2009; and
- 2007 NSTI Nanotechnology Conference and Trade Show. Santa Clara, CA. May 20-24, 2007.

### **3.2.3 Databases of Nanotechnology Research**

To further supplement the literature and information sources used to draft this report, the following publicly-available databases listing nanotechnology environmental and toxic effects research were identified and reviewed:

- International Council on Nanotechnology (ICON)'s Environmental Health and Safety Database (<http://icon.rice.edu/research.cfm>);
- Project on Emerging Nanotechnologies's Inventory of Current Nanotechnology Health and Environmental Implications Research (<http://www.nanotechproject.com/index.php>);
- National Institute for Occupational Safety and Health (NIOSH)'s Nanoparticle Information Library (NIL) (<http://www2a.cdc.gov/niosh-nil/index.asp>);
- American Institute of Chemical Engineers (AIChE) Nanoscale Science Engineering Forum (NSEF) (<http://www.aiche.org/DivisionsForums/ViewAll/NSEF.aspx>);

- 
- United States National Library of Medicine Toxicology Data Network (TOXNET) (<http://toxnet.nlm.nih.gov/>); and
  - Institute of Occupational Health's (UK) SAFENANO Publication Database Search (<http://www.safenano.org/AdvancedSearch.aspx>).

### **3.3 Contacts with Industry and Academic Experts**

To further supplement the literature and information sources, prominent researchers actively working with nano-TiO<sub>2</sub> and industry representatives that manufacture, process, and use nano-TiO<sub>2</sub> were identified and subsequently contacted as part of Search Strategy #3. Contact discussions included ecological and toxicological information; domestic manufacturing and processing; and the nano-TiO<sub>2</sub> supply chain. A list of researchers and stakeholders that were contacted is provided in Table 3-4.

---

**Table 3-4. List of Contacted Researchers**

<b>Name</b>	<b>Title/Office/Department</b>	<b>Organization</b>
Patricia Aikens	Technical Services Manager, Skin & Sun Care	BASF Corporation
Don Baer	Chief Scientist for Scientific Programs, Environmental Molecular Science Laboratory	Pacific Northwest National Laboratory
Venkat Bhethana	Professor, Chemical and Biological Engineering Department	University of South Florida and AIChE's Nanoscale Science & Engineering Forum
Shaun Clancy	Director, Product Regulatory Services	Degussa Corporation
Raymond M. David	Manager, Toxicology	BASF Corporation
Suzanne Davis	Staff, Department of Toxic Substances Control	California EPA
Brian Englert	US EPA, Office of Water	US EPA, OW
Larry Erickson	Professor, Department of Chemical Engineering	Kansas State University
Michael Hochella	Professor, NanoBioEarth, Department of Geoscience	Virginia Tech
Fred Klaessig	Manager, Pennsylvania Bio Nano Systems	Pennsylvania Bio Nano Systems, LLC
Kristen Kulinowski	Director for External Affairs, Center for Biological and Environmental Nanotechnology (CBEN)	Rice University and International Council on Nanotechnology (ICON)
R. Lee Penn	Associate Professor, Department of Chemistry	University of Minnesota
Bob Phaneuf	Engineer, Hazardous Waste Engineering, Division of Solid & Hazardous Materials	New York State Department of Environmental Conservation (NYSDEC)
Marc Reith	Quality Assurance Manager, NanoScale Corporation	Nanoscale Corporation
Olga Koper	VP Technology and CTO (Nanoscale); and adjunct professor (Kansas State University)	Nanoscale Corporation
Ron Turco	Professor, Department of Agronomy	Purdue University
Mark Wiesner	Director, Center for the Environmental Implications of Nanotechnology (CEINT)	Duke University
Jeff Wong	Executive Officer, Department of Toxic Substances Control	California EPA
Mike Wong	Professor, Department of Chemical Engineering and AIChE's NSEF Chair	Rice University
J. Michael Davis	Chair, Office of Research and Development (ORD), National Center for Environmental Assessment (NCEA)	ORD/NCEA
Paul Westerhoff	Professor and Head, School of Sustainable Engineering and the Built Environment	Arizona State University

### **3.4 Results and Areas for Future Work**

The three search strategies yielded a large body of information that was reviewed for inclusion in this report, including:

- 1,351 titles identified by Dialog® (i.e., Search Strategy #1; of this amount, 96 titles warranted acquisition and detailed review);

- 
- 46 additional published articles, 13 conference abstracts/proceedings, and 6 nanotechnology research databases identified through a search of targeted sources (i.e., Search Strategy #2); and
  - Discussions with 21 prominent researches (i.e., Search Strategy #3).

Table 3-5 presents the articles that were selected and reviewed in detail for this report and the general topic areas covered by each article. This list includes articles that were identified by Dialog® and articles that were identified during the review of targeted literature sources and personal contacts.

From these sources, the following information was identified:

- Manufacturing processes used to produce nano-TiO<sub>2</sub>;
- Uses of nano-TiO<sub>2</sub> in consumer products and emerging applications (current and potential);
- Fate and transport mechanisms of nano-TiO<sub>2</sub>
- A body of literature deliberating the ecological and toxicological effects of nano-TiO<sub>2</sub>; and
- Environmental sampling and analysis techniques applicable to nano-TiO<sub>2</sub>.

As a state-of-the-science review, this document is a “living” document and may benefit from additional research. Regarding some specific areas of interest, literature was available, but the overall level of information extracted from these sources was limited. The body of information reviewed for this report suggests that the application of nano-TiO<sub>2</sub> and its subsequent impacts on the environment is a growing area of research and it is generally recognized the affects need to be further studied and better understood by the scientific community. Additional research to address data gaps is recommended pertaining to:

- The production volumes of nano-TiO<sub>2</sub> for various industrial sectors and products (both domestic and imported);
- The identity of manufacturers and importers of nano-TiO<sub>2</sub>;
- The percentage of production volume used for each specific nano-TiO<sub>2</sub> application;
- Information specific to processing quantities, locations, and end-use markets for nano-TiO<sub>2</sub> products;
- Market representation of each application of nano-TiO<sub>2</sub> (e.g., nano-TiO<sub>2</sub> sunscreen market as a percentage of the total sunscreen market);
- Information pertaining to the specific fate and transport of nano-TiO<sub>2</sub> through environmental compartments;
- The geographic and seasonal variations of exposures to nano-TiO<sub>2</sub>-based products (e.g., exposure to nano-TiO<sub>2</sub> from sunscreen is more likely during the summer, in regions located near bodies of water, and winter ski resorts);
- An understanding of how particle properties such as pore volumes and primary, secondary, and tertiary particle sizes factor into the deliberation of the ecological and toxicological effects of nano-TiO<sub>2</sub>; and
- Sampling analyses for soil and air media for differentiating anthropogenic nanomaterials from natural nanomaterials.

**Table 3-5. Articles Reviewed for Literature Search**

Article Citation	Lifecycle			Fate and Transport				Health Effects		Sampling					Analysis					
	Production Volumes and Manufacturers	Uses and Markets	Process Information	Surface Water	Soil	Groundwater	Air	Human Toxicity	Ecological Toxicity	Surface Water	Sediment	Soil	Groundwater	Air	Size Fractionation	Size Distribution/Surface Area	Direct Visualization	Mineral Phase/Internal Structure	Chemical Analysis	Differentiation of Anthropogenic Nanomaterials
Brar et al. Engineered Nanoparticles in Wastewater and Wastewater sludge - Evidence and Impacts				X																
Burleson, et al. On the Characterization of Environmental Nanoparticles															X	X	X	X		
Chen, et al. Role of the Air-Water Interface in the Retention of TiO <sub>2</sub> Nanoparticles in Porous Media During Primary Drainage				X																
Chen, et al. Ultrafine Titanium Dioxide Nanoparticles Induce								X												

Cell Death in Human Bronchial Epithelial Cells																			
Chen, X. Titanium Dioxide Nanomaterials: Synthesis, Properties, Modifications, and Applications		X																	
Chin Choy. Injection of Nanocrystalline Titanium Dioxide into Porous Media for Uranium Contaminated Groundwater Remediation		X			X	X													
China Chemical Reporter. Silver-Supported Nanometer Titanium Dioxide Antibacterial Material		X																	
Doucet, F. Visualisation of Natural and Aquatic Colloids and Particles- A Comparison of Conventional High Vacuum and Environmental Scanning Electron Microscopy															X	X			
DuPont. Nanomaterial Risk Assessment Worksheet DuPont Light Stabilizer	X				X	X		X	X	X									
Eckels, et al. Nanoscale Materials in Chemistry: Environmental Applications; Nanoscale Catalysts and In-Room Devices to Improve Indoor Air Quality and Sustainability		X																	

Englert. Nanomaterials and the environment: uses, methods and measurement																			X
Environmental Protection Agency. Nanomaterial Case Studies: Nanoscale Titanium Dioxide (External Review Draft).	X	X	X	X	X		X	X	X										
Eriksson, E. A Substance Flow Analysis and Source Mapping of Chemical UV-Filters.			X																
Evonik Degussa Corp. Aerosil Product Finder Website.	X	X																	
Evonik Degussa Corp. NMSP Submission for Titanium Oxide	X	X	X					X	X										
Fang, et al. Stability of Titania Nanoparticles in Soil Suspensions and Transport in Saturated Homogeneous Soil Columns					X														
Fryxell. Nanomaterials for Environmental Remediation											X								
Gilbert, B. Stable cluster formation in aqueous suspensions of iron oxyhydroxide nanoparticles															X				
Gimbert, L. Partitioning and Stability of Engineered ZnO Nanoparticles in Soil Suspensions Using											X			X					

Field-Flow Fractionation																			
Gimbert, L. The Influence of Sample Preparation on Observed Particle Size Distributions for Contrasting Soil Suspensions using Flow Field-Flow Fractionation												X							
Gontier, et al. Is There Penetration of Titania Nanoparticles in Sunscreens through Skin? A Comparative Electron and Ion Microscopy Study								X											
Gottschalk, et al. Probabilistic Material Flow Modeling for Assessing the Environmental Exposure to Compounds: Methodology and an Application to Engineered Nano-TiO2 Particles				X	X	X	X												
Guzman, et al. Influence of Surface Potential on Aggregation and Transport of Titania Nanoparticles				X															
Handy. Case Study: Biological Effects of Nanomaterials									X										



Kiser, M.A. Titanium Nanomaterial Removal and Release from Wastewater Treatment Plants.				X														
Klaine, S. Nanomaterials in the Environment: Behavior, Fate, Bioavailability, and Effects											X							
Kobo Products. Sunscreen Technologies.		X	X															
Labbe. Photocatalytic Degradation of Select Drinking Water Pollutants Using Nano-TiO2 Catalyst		X																
Lecoanet. Laboratory Assessment of the Mobility of Nanomaterials in Porous Media											X							
Li. Removal of Elemental Mercury from Flue Gas Using Nanostructured Silica/Titania/Vanadia Composites		X																
Liao, et al. Assessing the Airborne Titanium Dioxide Nanoparticle-Related Exposure Hazard at Workplace								X										
Liao, et al. Model-Based Assessment for Human Inhalation Exposure Risk to Airborne Nano/Fine Titanium Dioxide Particles								X										

<p>Lovern, et al. Behavioral and Physiological Changes in Daphnia magna when Exposed to Nanoparticle Suspensions (Titanium Dioxide, Nano-C60, and C60HxC70Hx)</p>									X										
<p>Mahmoodi and Arami. Degradation and Toxicity Reduction of Textile Wastewater Using Immobilized Titania Nanophotocatalysis.</p>		X																	
<p>Mueller, et al. Exposure Modeling of Engineering Nanoparticles in the Environment</p>				X	X		X		X										
<p>NanoScale Corporation. NanoActive TiO2 Safety Testing.</p>								X											
<p>NanoScale Corporation. NanoActive Titanium Dioxide Product Sheet.</p>	X	X																	
<p>NanoScale Corporation. www.nanoscalecorp.com</p>	X	X																	
<p>NIOSH. NIOSH Current Intelligence Bulletin: Evaluation of Health Hazard and Recommendations for Occupational Exposure to Titanium Dioxide</p>								X											
<p>Niu, et al. Degradation of Polycyclic Aromatic Hydrocarbons in Water/Methanol Solutions with Nanoparticle</p>		X																	

Photocatalysts Based on Silver Doped TiO <sub>2</sub>																			
Noack, A. Colloid Movement Through Stable Soils of Low Cation-Exchange Capacity											X								
Nowack, B. Heavy Metals in the Environment.									X	X	X	X	X						
Ou and Lo. Review of Titania Nanotubes Synthesized via the Hydrothermal Treatment: Fabrication, Modification, and Application		X																	
Prasad, et al. Decontamination of Sulfur Mustard and Sarin on Titania Nanotubes		X																	
Quang et al. Characterization and Separation of Inorganic Fine Particles by Capillary Electrophoresis with an Indifferent Electrolyte System																			X
Ramsden, et al. Dietary Exposure to Titanium Dioxide Nanoparticles in Rainbow Trout, ( <i>Oncorhynchus mykiss</i> ): No Effect on Growth,									X										

but Subtle Biochemical Disturbances in the Brain																			
Robichaud, et al. Estimates of Upper Bounds and Trends in Nano-TiO2 Production As a Basis for Exposure Assessment	X	X	X																
Sadrieh, et al. Lack of Significant Dermal Penetration of Titanium Dioxide (TiO2) from Sunscreen Formulations containing Nano- and Sub-Micron-Size TiO2 Particles								X											
Sayes, et al. Correlating Nanoscale Titania Structure with Toxicity: A Cytotoxicity and Inflammatory Response Study with Human Dermal Fibroblasts and Human Lung Epithelial Cells								X											
Schmidt and Vogelsberger. Aqueous Long-Term Solubility of Titania Nanoparticles and Titanium(IV) Hydrolysis in a Sodium Chloride System Studied by Adsorptive Stripping Voltammetry					X														



Wigginton, N.S. Aquatic Environmental Nanoparticles																X	X	X
Willis, R.C. When Size Matters.													X					
Woodrow Wilson Center. Project on Emerging Nanotechnologies: Consumer Products Inventory		X																
Wu, et al. Assessment of Toxicity of Metal Oxide Nanoparticles to Microbial Species							X	X										
Yang, et al. Photocatalytic Activity of Multi-Doped TiO2 Nanoparticles for Degredation of Rhodamine B		X																
Yang, et al. Photocatalytic degradation of Rhodamine B on C-, S-, N-, and Fe-Doped TiO2 under Visible-Light Irridation		X																
Zhang, et al. Sorption of Thallium(III) Ions from Aqueous Solutions Using Titanium Dioxide Nanoparticles		X																
Zhang, et al. The Removal of Sodium Dodecylbenzene Sulfonate Surfactant from Water Using Silica/Titania Nanorods/Nanotubes Composite Membrane		X																

with Photocatalytic Capability																				
Zhang, Plasma Synthesis of Metal Oxide Nanoparticles	X	X	X																	
Zhang. Fate, Transport and Toxicity of Nanomaterials in Drinking Water				X				X												
Zucker, R.M. Detection of TiO2 Nanoparticles in Cells by Flow Cytometry																X				
<b>Total</b>	<b>10</b>	<b>28</b>	<b>8</b>	<b>10</b>	<b>6</b>	<b>2</b>	<b>4</b>	<b>15</b>	<b>9</b>	<b>2</b>	<b>3</b>	<b>6</b>	<b>2</b>	<b>1</b>	<b>3</b>	<b>7</b>	<b>3</b>	<b>2</b>	<b>3</b>	<b>0</b>

---

#### 4. BACKGROUND OF TITANIUM DIOXIDE AND ITS USE

This section provides the reader with a general background of titanium dioxide and its industrial uses, both at the nanoscale and in bulk, macrosized form. This includes a discussion of the basic chemical and physical properties, historical uses unique to those characteristics, and relatively new uses based on enhanced properties at the nanoscale.

The physical and chemical properties that make TiO<sub>2</sub> attractive as a component of various consumer products and applications are outlined along with their uses and applications.

##### 4.1 Titanium Dioxide Physical and Chemical Properties

Basic chemistry and physical properties of TiO<sub>2</sub> have been understood and used by man for centuries. This knowledge is outlined in the following paragraphs.

##### Crystalline Phases

TiO<sub>2</sub> naturally occurs as crystalline phases: anatase, rutile, and brookite<sup>2</sup>. Of these phases, anatase and rutile are the most commonly encountered. Rutile is the thermodynamically stable form of TiO<sub>2</sub> at all temperatures and at normal pressures.

##### Natural Occurrence of TiO<sub>2</sub>

TiO<sub>2</sub> is found in abundance in nature as the minerals ilmenite (FeTiO<sub>3</sub>), rutile (TiO<sub>2</sub>), and sphene (CaSiTiO<sub>5</sub>) among others<sup>3</sup>. Ilmenite and rutile are the predominant forms of TiO<sub>2</sub> and these minerals are mined throughout the world<sup>4</sup>. The top three global mine producing countries of ilmenite and rutile ores are presented in Table 4-1<sup>4</sup>. In the United States, ilmenite and rutile concentrates come from surface-mining operations in Florida and Virginia. U.S. production data of ilmenite and rutile ore from these mines are not presented to protect company proprietary data. Comparing the combined production of ilmenite and rutile ore, the U.S. is the seventh largest global producer<sup>4</sup>. In addition to ilmenite and rutile ores, large deposits of anatase-bearing ore are found and mined in Brazil<sup>2</sup>. However, ilmenite supplies approximately 92 percent of the global demand for titanium minerals.<sup>4</sup>

**Table 4-1. Top Global Producers of TiO<sub>2</sub> Mineral Ores**

Rank	Ilmenite Ore	Rutile Ore
1	Australia	Australia
2	South Africa	South Africa
3	Canada	Ukraine
7	United States <sup>1</sup>	

<sup>1</sup> U.S. ilmenite and rutile ore production data are combined to protect company proprietary data. The U.S. rank provided is based on the combination of ilmenite and rutile production.

---

TiO<sub>2</sub> mineral ores are used to produce processed TiO<sub>2</sub> (e.g., pigmentary TiO<sub>2</sub>) as well as titanium sponge metal. Titanium sponge metal is processed into ingots for further processing into wrought products and castings. These titanium metal products and castings are further fabricated into specific product applications, such as for aerospace, armor, chemical processing, and sporting goods applications.<sup>4</sup> This state-of-the-science literature review focuses on processed TiO<sub>2</sub> (pigmentary and particularly nanoscale) and does not further discuss titanium metal.

### **Physical Properties**

The primary physical properties that affect the utility of TiO<sub>2</sub> for industrial applications and use in consumer products include density, melting point, and refractive index. The theoretical density of TiO<sub>2</sub> ranges from 3895 kg/m<sup>3</sup> for anatase to 4250 kg/m<sup>3</sup> for rutile<sup>2</sup>. The melting point of rutile ranges from 1830 °C to 1850 °C. Anatase transitions to rutile upon heating before melting. This phase change occurs across a broad temperature range of about 500 °C to 900 °C, depending on the sample. Specifics such as crystallite diameter, weight fraction (if in a mixture), and heat intensity affect the onset and kinetics of the phase transition. The refractive indexes of rutile and anatase are approximately 2.75 and 2.54, respectively<sup>2</sup>.

### **Aggregation and Agglomeration Mechanisms**

Nanoscale primary particles of TiO<sub>2</sub>, such as those formed during a pyrogenic reaction, may fuse together to form an aggregate. An aggregate is a fused assembly of primary particles that typically do not break down into the original primary particles. Aggregates may coalesce to form more transient agglomerates. Agglomerates may require strong forces to break them down. Pyrogenic TiO<sub>2</sub> may form primary particles on the order of 10 to 20 nm in size that only exist for 10 to 200 milliseconds before forming aggregates and agglomerates. The aggregates may range from 0.1 to 1 μm in size, and the agglomerates may range from 1 to 250 μm in size<sup>5</sup>. Additional research is required to determine the rate of disaggregation of nanoscale TiO<sub>2</sub> that enters the environment.

## **4.2 Overview of Applications of Titanium Dioxide**

The historical uses of TiO<sub>2</sub> (i.e. macrosized) are examined and briefly discussed in this section. The current and projected applications of nanoscale TiO<sub>2</sub> are presented.

### ***4.2.1 Historical Applications of Titanium Dioxide***

Due to its refractive index, macroscale TiO<sub>2</sub> has found many uses as a pigment for both white and color systems for decades. TiO<sub>2</sub> is often used as a white pigment not only due to its opacifying properties but also because the technology is available to manufacture pigment TiO<sub>2</sub> at the necessary size range and purity<sup>2</sup>. Pigmentary TiO<sub>2</sub> is often manufactured with a median particle size of 250 nm to 350 nm.<sup>3</sup> The most common pigment use of TiO<sub>2</sub> in the U.S. is in surface coatings. Surface coatings include liquid paints and powder coatings. After surface coatings, the largest use of pigmentary TiO<sub>2</sub> in the U.S. is in plastics. Applications of pigment TiO<sub>2</sub> also include paper, printing inks, and fibers. TiO<sub>2</sub> may be incorporated into rubber and leather products in small quantities to impart a high degree of whiteness while permitting the product to retain most of the natural properties of the rubber or leather<sup>2</sup>.

Pigment grade TiO<sub>2</sub> is often used in applications where its chemical and biological inert properties as well as pigment properties are advantageous. These inert properties also lead to its use in cosmetics, soaps, pharmaceuticals, and certain food products where whiteness is desired for marketing reasons. The inert properties of macroscale TiO<sub>2</sub> also allow its use as a support for catalysts<sup>2</sup>.

Macroscale TiO<sub>2</sub> also finds use in non-pigment applications. TiO<sub>2</sub> is used in welding electrodes as a fluxing agent, slag former, and shade modifier. It is also used in ceramics due to its chemical properties in addition to its pigment properties. Specifically, TiO<sub>2</sub> is used to produce a white hue, as a pigment, or provide a high refractive index of the glass as an opacifier. It is also incorporated into electroceramics due to its high dielectric constant<sup>2</sup>.

In 2007, 1,450,000 metric tonnes of pigment grade TiO<sub>2</sub> were manufactured from ore in the United States by four companies operating eight facilities in seven States<sup>4</sup>. The estimated end-use markets of pigment grade TiO<sub>2</sub> in the U.S. and corresponding market share of these 2007 data expressed as a percentage are as follows<sup>4</sup>:

- Paint (including lacquers and varnishes): 57%;
- Plastic: 26%;
- Paper: 13%;
- Other: 4%; which consists of:
  - Catalysts;
  - Ceramics;
  - Coated fabrics and textiles;
  - Floor coverings;
  - Printing ink; and
  - Roofing granules.

Table 4-2 provides a summary of the U.S. production, import, export, and consumption of TiO<sub>2</sub> pigment from 2003 to 2007<sup>4</sup>.

**Table 4-2. Annual Volumes of Total TiO<sub>2</sub> in the United States**

	Annual Volumes of Total TiO <sub>2</sub> (metric tonnes)				
	2003	2004	2005	2006	2007
Production	1,420,000	1,540,000	1,310,000	1,400,000	1,450,000
Imports for Consumption	240,000	264,000	341,000	288,000	260,000
Exports	584,000	635,000	524,000	581,000	600,000
Apparent Consumption <sup>1</sup>	1,070,000	1,170,000	1,130,000	1,110,000	1,110,000

<sup>1</sup> Apparent consumption is defined as production plus imports for consumption less exports.

---

#### ***4.2.2 Applications of Nanoscale Titanium Dioxide***

Contrary to pigmentary TiO<sub>2</sub>, nano-TiO<sub>2</sub> is not inert and is a UV light attenuator. Therefore, it finds applications as a catalyst and as a UV light attenuator as opposed to a visible light attenuator (i.e., pigment). The applications of nano-TiO<sub>2</sub> identified in this review generally fall into one of two categories: 1) applications that use nano-TiO<sub>2</sub> to attenuate UV light and 2) applications that use nano-TiO<sub>2</sub> as a catalyst or semiconductor.

Applications that use nano-TiO<sub>2</sub> to attenuate UV light include consumer products such as sunscreens or similar cosmetics, various plastic-based products and containers, and clothing. Applications that use nano-TiO<sub>2</sub> as a catalyst include various consumer products such as household cleaning products, household self-cleaning coatings, household air filtration devices, electronics (e.g., computer keyboard and mouse), and hair styling devices. Commercial applications also include cleaning products, self-cleaning coatings, air filtration devices, and environmental remediation of pollutants. Emerging applications include solar cells that use nano-TiO<sub>2</sub> for its electron transfer properties. Section 5 discusses the applications of nano-TiO<sub>2</sub> in greater detail.

---

## 5. LIFE CYCLE OVERVIEW

This section outlines the life cycle overview of nano-TiO<sub>2</sub> for various applications. Applications are categorized as currently commercially-available applications or emerging and potential applications. This section discusses individual life cycle stages. Section 6 discusses the subsequent exposure pathways associated with the life cycle stages identified in this section.

### **Currently Commercially-Available Applications**

A variety of nano-TiO<sub>2</sub> applications have been identified in currently commercially-available products and/or processes in the United States. Products utilizing TiO<sub>2</sub> for UV filtration or as a photocatalyst are most prevalent; however, other uses and corresponding applications have also been identified. Although specific applications have been identified, the production volume of nano-TiO<sub>2</sub> used in each application and the market share of the nano-TiO<sub>2</sub>-enhanced products in each market segment are unknown.

#### *UV Filters*

Nano-TiO<sub>2</sub> is used in various applications as a UV filter or blocker. In these applications, nano-TiO<sub>2</sub> attenuates UV light. Attenuation is the combined effect of absorbing and scattering incident light. Nano-TiO<sub>2</sub> is found as a UV filter in the following products and applications<sup>6</sup>:

- UV filter in sunscreens and cosmetics;
- UV filter in plastics (e.g., DuPont's Light Stabilizer 210); and
- UV filter in clothing.

#### *Photocatalysts*

Nano-TiO<sub>2</sub> is used in various applications for its photocatalytic properties. In these applications, nano-TiO<sub>2</sub>, in the presence of light, catalyzes the degradation or other reaction of undesired chemicals or microorganisms. Nano-TiO<sub>2</sub> is currently used as a photocatalyst in the following applications<sup>6</sup>:

- Cleaning products;
- Self-cleaning coatings;
- Electronic products;
- Hair styling devices;
- Air filtration; and
- Environmental remediation.

As an example of large scale corporate use of nano-TiO<sub>2</sub>, we present NanoScale Corporation which manufactures multiple products that use nanomaterial metal oxides for the following catalytic applications<sup>7</sup>:

- Environmental remediation;
- Gas scrubbing;
- Materials synthesis;
- Odor abatement;

- Environmental pollutant removal; and
- Detoxification and neutralization of harmful and deadly chemical substances, toxins, viruses, and fungi.

NanoScale Corporation’s customers include hazardous material (HAZMAT) emergency responders (at state and local levels), the Department of Defense, and commercial and academic laboratories. Although NanoScale Corporation does not identify the components of their various remediation and decontamination products, they do identify potential catalytic applications of their nano-TiO<sub>2</sub> including<sup>8</sup>:

- Chemical and pollutant remediation;
- Smoke removal;
- Personal protective equipment;
- Self-cleaning paints and coatings; and
- Catalysts for hydrogen synthesis.

*Other Applications*

Nano-TiO<sub>2</sub> is further used in other, smaller markets. For example, nano-TiO<sub>2</sub> has been identified as being used in catalyst support applications<sup>5</sup>.

Several of the current commercially available applications are found in consumer products. The Woodrow Wilson Center’s Project on Emerging Nanotechnologies maintains a Consumer Products Inventory of nanomaterial-enhanced consumer products<sup>6</sup>. As of April 12, 2010, this database included 32 products that contained nano-TiO<sub>2</sub>. These consumer products can be placed into several categories as show in Table 5-1.

**Table 5-1. Summary of Consumer Product Categories that Use Nano-TiO<sub>2</sub> from the Project on Emerging Nanotechnologies Consumer Products Inventory**

Consumer Product Category	Number of Items in Database
Sunscreens	9
Cosmetics	3
Self-cleaning Coatings	7
Air Filtration	2
Plastics <sup>1</sup>	1
Hair Styling Devices	4
Electronics	5
Clothing	1

<sup>1</sup>The “plastic” consumer product identified in the Consumer Products Inventory is actually the DuPont Light Stabilizer 210, which is a UV stabilizer added to plastic products and not a plastic product itself.

---

## **Emerging and Potential Applications**

New research has identified a number of emerging and potential applications of nano-TiO<sub>2</sub>. These applications are still in the research and development phase and/or represent small, emerging market shares. They focus on the catalytic, photocatalytic, and conductive properties of nano-TiO<sub>2</sub><sup>9</sup>.

Multiple research projects identified a focus on the catalytic and photocatalytic properties of nano-TiO<sub>2</sub> specifically for application in environmental remediation. These applications include the degradation or adsorption of contaminants from water<sup>10,11,12,13,14,15,16,17</sup>, groundwater<sup>18,19</sup>, and air<sup>20,21</sup>. The contaminants include Thallium(III) ions (from aqueous solutions), sodium dodecylbenzene sulfonate surfactant, rhodamine B, and polycyclic aromatic hydrocarbons. The photodecomposition mechanisms typically involve one or more radicals or intermediate species such as ·OH, O<sup>2-</sup>, H<sub>2</sub>O<sub>2</sub>, or O<sub>2</sub>, which are generated from the absorption of photons by the nano-TiO<sub>2</sub><sup>22</sup>. An additional remediation application currently under research includes the decontamination of chemical warfare agents<sup>23</sup>.

Due to its electrochemical properties, nano-TiO<sub>2</sub> holds a potential application in dye-sensitized solar cells. Dye-sensitized solar cells have low efficiencies, reaching upwards of only 11 percent. However, researchers are using TiO<sub>2</sub> nanotubes, instead of nanoparticles, to improve these efficiencies; due to the TiO<sub>2</sub> nanotubes efficiency improvement of the electron transport from the photovoltaic cell to the negative electrode<sup>24</sup>. The electrochemical properties of nano-TiO<sub>2</sub> have application in improving the efficiency of lithium ion batteries through the use of TiO<sub>2</sub> nanotubes<sup>9</sup>.

Research in China is being conducted on the potential use of nano-TiO<sub>2</sub> as a support for antimicrobial silver ions. In this application, the silver ions are used for their antimicrobial activity with a nano-TiO<sub>2</sub> support that provides a slow release of the silver ions<sup>25</sup>.

Potential application still under research and development is the use of nano-TiO<sub>2</sub> in treating brain cancer. Researchers are developing a therapy that uses nano-TiO<sub>2</sub> bonded with biomolecules. Using an antibody, the locally-applied nano-TiO<sub>2</sub> targets the cancerous brain cells. Focused visible light is shined onto the area, causing the photocatalytic TiO<sub>2</sub> to generate free oxygen radicals. The free oxygen radicals interact with the mitochondria in the cancer cells and trigger cell death of these cancer cells<sup>26</sup>.

Also to note, ongoing research has been on the use of nano-TiO<sub>2</sub> as a support or carrier for various catalysts, such as platinum-gold nanoparticle catalysts<sup>9</sup>.

The following subsections describe the life cycle of nano-TiO<sub>2</sub> for each application.

### **5.1 Manufacture of Nano-TiO<sub>2</sub>**

Methods to manufacture nano-TiO<sub>2</sub> vary widely. This state-of-science review has not identified whole-scale differences in manufacturing processes, unique to each specific application of nano-TiO<sub>2</sub>. However, multiple sources indicate that some modifications may be made during a manufacturing process to affect certain properties of nano-TiO<sub>2</sub> for the desired application.

---

In general, two commercial processes are used to produce pigment grade TiO<sub>2</sub>: the sulfate process and the chloride process. This review has identified commercial processes that use the chloride process to produce nano-TiO<sub>2</sub> but it is uncertain whether the sulfate process is used (no literature sources and none of the industrial or academic contacts identified commercial sulfate processes). The chloride process accounts for a majority of pigmentary TiO<sub>2</sub> produced globally and within the U.S. The chloride process is preferred over the sulfate process due to economic and environmental concerns. A third process, the sol-gel process, is used to produce specifically nano-TiO<sub>2</sub>.

### **TiO<sub>2</sub> Feedstocks**

Titanium, the ninth most common element in Earth's crust, occurs naturally in the minerals rutile (TiO<sub>2</sub>) and ilmenite (FeTiO<sub>3</sub>) and to a lesser degree in other minerals<sup>3,4</sup>. Rutile ore from Australia and South Africa typically contains approximately 95% by weight TiO<sub>2</sub>. The ilmenite content of TiO<sub>2</sub> ranges from 44% in Norway, to 55% in Australia, and 65% in Florida, U.S. (the only identified domestic location). Ilmenite must be processed to remove iron before the TiO<sub>2</sub> may be chlorinated to produce titanium tetrachloride. This processing of ilmenite produces synthetic rutile. Synthetic rutile typically contains approximately 94% by weight TiO<sub>2</sub><sup>2</sup>.

U.S. Geological Survey (USGS) data from 2007 estimate that ilmenite supplies approximately 92% of the global demand for titanium minerals. The remaining 8% of this demand is supplied by rutile ore. These 2007 USGS data also indicate that Australia accounted for the greatest ilmenite and rutile mine production per country with approximately 25% of the global mine production of ilmenite and rutile combined. Australia was followed by South Africa with approximately 17% of the global mine production of ilmenite and rutile combined. The U.S. accounted for only 5% of the global mine production of ilmenite and rutile combined<sup>4</sup>.

### **Chloride Process**

After the mining and processing of the titanium feedstock, the second step of the chloride process is the chlorination of the titanium-containing mineral under reducing conditions. Detailed publicly-available process and unit operation descriptions have not been identified and are typically considered proprietary. Therefore, this section presents a general process description of the chlorination step.

Rutile ore or synthetic rutile processed from ilmenite can be used to produce titanium tetrachloride (TiCl<sub>4</sub>). This method is typically performed as a continuous process in a fluidized-bed reactor. TiO<sub>2</sub> feedstock and coke are mixed together and constitute the reactor bed. Chlorine is supplied countercurrently as the fluidizing fluid. The reaction takes place at approximately 1,000 °C. The TiCl<sub>4</sub> produced at this temperature is in a gaseous state. Reaction 1 illustrates the stoichiometry of the thermodynamically favored reaction<sup>2</sup>.



After chlorination, the resulting TiCl<sub>4</sub> requires purification. The rutile raw material (whether rutile ore or synthetic rutile) may contain various metal impurities, such as iron oxides and vanadium oxides. These metal impurities are chlorinated during the reaction and exit the reactor with the TiCl<sub>4</sub> product. The TiCl<sub>4</sub> is purified through a sequential process. The reactor product is

first condensed and impurities are removed by a solids separator and liquid scrubbing system. The  $\text{TiCl}_4$  product is further purified by fractional distillation. Vanadium oxychloride boils at a similar temperature as  $\text{TiCl}_4$  and is not sufficiently removed during distillation. The vanadium oxychloride impurity is removed by reduction and conversion into a nonvolatile sludge<sup>2</sup>.

The third step of the chloride process is the oxidation of  $\text{TiCl}_4$  to produce nano- $\text{TiO}_2$ . The method described here is the DuPont plasma synthesis of metal oxide nanoparticles<sup>27</sup>. This process is described in a patent by Zhang and assigned to DuPont on May 15, 2007. This patent presents the most complete publicly-available process data located as of 2009.

Oxygen gas is bubbled through a tank of liquid  $\text{TiCl}_4$  maintained at room temperature. This premixed vapor stream of oxygen and  $\text{TiCl}_4$  is fed into the reaction chamber. The plasma gas stream, a mixture of argon and hydrogen (hydrogen content is 1% to 5% of plasma stream) is fed into the energy source (the DC arc plasma torch). The plasma carrier gas stream is brought to approximately 6,000 °C and enters the reaction chamber where it contacts the reactant feed. The reaction occurs in the reaction chamber and continues until the quenching chamber is reached. Here, room temperature oxygen is added to quench the aerosol mixture exiting the reaction chamber. The quenching reduces the rate of particle coagulation and aggregation. The  $\text{TiO}_2$  product is then collected downstream in the product collector. In this case, a sintered metal filter is used. The gas flow exiting the product collector is discharged into a scrubber<sup>27</sup>. Figure 5-1 illustrates this process. Reaction 2 illustrates the stoichiometry of this reaction.

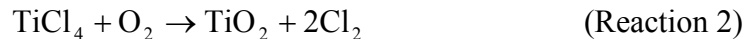

In general with the chloride process, additives may be introduced during  $\text{TiO}_2$  synthesis to determine the crystalline phase of the  $\text{TiO}_2$  product. After synthesis, the  $\text{TiO}_2$  may undergo post-treatment processing such as milling and surface coating<sup>2</sup>.

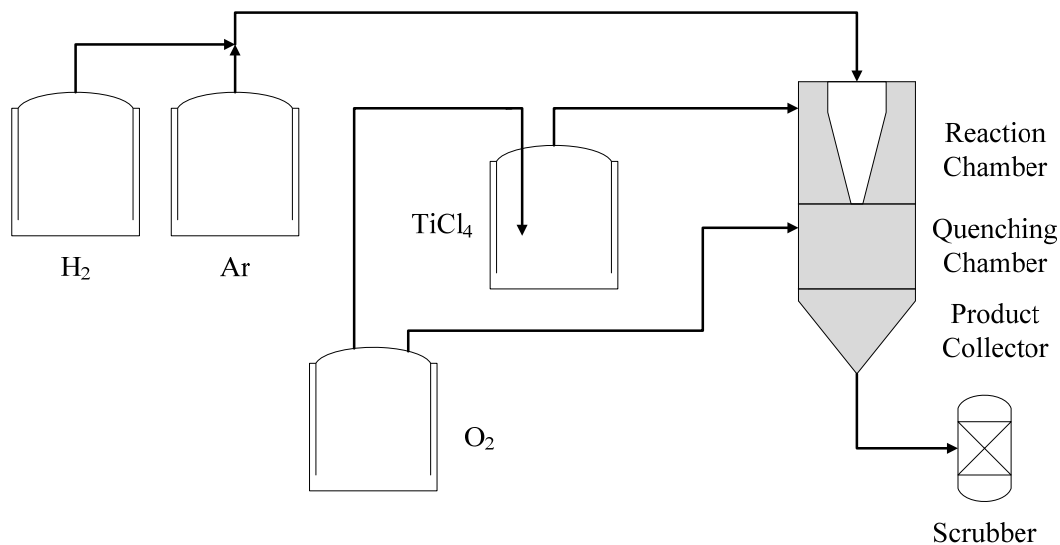

**Figure 5-1. Nano- $\text{TiO}_2$  Manufacturing Process Diagram According to the DuPont Patent**

---

## **Sulfate Process**

The sulfate process was the earliest process used to manufacture pigmentary TiO<sub>2</sub>. The iron sulfate wastes produced by the sulfate process present an environmental concern. Therefore, the chloride process is currently favored over the sulfate process due to economic and environmental considerations<sup>2</sup>.

The sulfate process is a batch or discontinuous process. The primary unit operations are as follows<sup>2</sup>:

- 1) Digestion: the reaction of a TiO<sub>2</sub>-containing mineral (usually ilmenite or slag) with sulfuric acid to form titanyl sulfate;
- 2) Precipitation of titanium dioxide hydrate by hydrolysis of the acid solution used for the digestion step;
- 3) Separation and washing of the hydrate; and
- 4) Calcination: the calcination process occurs in the temperature range of about 900 to 1,000 °C and leads to the thermal formation of pure TiO<sub>2</sub> crystals.

After calcination, the TiO<sub>2</sub> is subsequently post-treated. Post-treatment processing may include milling, dispersion, and/or surface coating<sup>2</sup>.

## **Sol-Gel Process**

The sol-gel process is used as a specialty nano-TiO<sub>2</sub> production process. Reaction 3 illustrates the typical synthesis route used by the sol-gel process.



Here, X can denote tetrachloride (Cl<sub>4</sub>), oxygen dichloride (OCl<sub>2</sub>), or an alkoxide (OR). The sol-gel process is unique in its ability to produce amorphous TiO<sub>2</sub>, which has several potential applications including environmental remediation, thin film optical coatings, and self-decontaminating surfaces. Amorphous TiO<sub>2</sub> cannot be produced through the high-temperature production processes such as plasma synthesis or flame pyrolysis. These production processes convert TiCl<sub>4</sub> to TiO<sub>2</sub> at high temperatures (6,000 °C and 1,000 °C for the respective process) and would prompt the phase transition from amorphous to anatase and rutile.

## **Production Volume of Nano-TiO<sub>2</sub>**

The exact production volume of nano-TiO<sub>2</sub> is uncertain and multiple contacts with industrial TiO<sub>2</sub> manufacturers have resulted in claims that this information is considered proprietary. However, estimated production and consumption volumes are presented. This work identified a reference that cites the global production of ultrafine TiO<sub>2</sub> as less than 0.25 percent of the global production of total TiO<sub>2</sub>.<sup>3</sup> This review assumes ultrafine TiO<sub>2</sub> exclusively includes nano-TiO<sub>2</sub> (both nanoscale and nanostructured). Similarly, it assumes that both the global and domestic production and consumption volumes of nano-TiO<sub>2</sub> are 0.25 percent of the global and domestic production and consumption of total TiO<sub>2</sub>. Table 5-2 provides a summary of these estimates.

**Table 5-2. Estimated Annual Volumes of Nano-TiO<sub>2</sub> Globally and in the United States**

Source	Total TiO <sub>2</sub> (Reported)			Nano-TiO <sub>2</sub> <sup>1</sup> (Estimated)		
	Global Production (tonne/yr)	U.S. Production (tonne/yr)	U.S. Consumption (tonne/yr)	Global Production (tonne/yr)	U.S. Production (tonne/yr)	U.S. Consumption (tonne/yr)
USGS (2007 values) <sup>4</sup>	N/A	1,450,000	1,110,000	N/A	3,630	2,780
DuPont <sup>3</sup>	5,000,000	N/A	N/A	12,500	N/A	N/A

<sup>1</sup> This reference estimated that the global production of ultrafine TiO<sub>2</sub> is <0.25% of the global production of total TiO<sub>2</sub>. The nano-TiO<sub>2</sub> estimates in this table assume both the global and U.S. production and consumption of nano-TiO<sub>2</sub> is 0.25% of the global and U.S. production and consumption of total TiO<sub>2</sub>.<sup>3</sup>  
 N/A: Not Applicable – the value was not provided in the given source.

The total TiO<sub>2</sub> values in Table 5-2 compare with values presented by Robichaud et al.<sup>28</sup> who cite a global total TiO<sub>2</sub> annual production volume of 4 million metric tonnes and a U.S. total TiO<sub>2</sub> annual production volume of 1.3 million metric tonnes in 2006. However, Robichaud et al. estimate a U.S. nano-TiO<sub>2</sub> production volume of 3,000 metric tonnes in 2002 and an increase to 44,400 metric tonnes in 2009. The U.S. nano-TiO<sub>2</sub> results in Table 5-2 estimate a 2007 production volume that is only 21 percent higher than Robichaud et al.’s 2002 estimate, whereas Robichaud et al. estimate an increase in 2009 of 1,380 percent from the 2002 estimate.

### **Packaging**

Pigment grade TiO<sub>2</sub> is traditionally sold in paper bags in 25-kg (approximately 50-lb) quantities. Specialized applications of pigment grade TiO<sub>2</sub> may use bags that can be added directly to the process without preliminary slitting and emptying. TiO<sub>2</sub> pigment for paper and latex paints is often delivered as an aqueous slurry by rail in the United States<sup>2</sup>.

Multiple sources identified packaging specific to nano-TiO<sub>2</sub> products. These packaging options include solids sold in 10-kg and 20-kg bags, 55-gallon drums, and totes; and liquid-based dispersions sold in 60-kg containers, 220-kg drums, and 1,000-kg intermediate bulk containers (IBCs)<sup>29</sup>.

### **Manufacturers of Nano-TiO<sub>2</sub>**

This section identifies nano-TiO<sub>2</sub> manufacturers, their potential facility locations, and their identified nano-TiO<sub>2</sub> products. These are summarized in Table 5-3. Note that these are only the identified and confirmed commercial manufacturers. Additional smaller, start-up manufacturers for niche markets may exist. Research and discussions with academic and commercial contacts have confirmed this list as the primary, known manufacturers that may supply the U.S. market.

**Table 5-3. Nano-TiO<sub>2</sub> Manufacturers, Facilities, and Identified Products**

<b>Company</b>	<b>Potential Facility Locations</b>	<b>TiO<sub>2</sub> Product</b>	<b>Potential Applications</b>	<b>Notes</b>
DuPont	DeLisle, MS; New Johnsonville, TN; Edge Moor, DE; Altamira, Mexico; Kuan Yin, Taiwan	DuPont Light Stabilizer 210	Polymer additive for UV protection	Sold as solid in bags. Median particle size is 130-140 nm.
Evonik Degussa	Uncertain	Aeroxide P25	Catalyst carrier; Photocatalytic reactions; Heat stabilizer for silicone	Sold as solid (10-kg bags). Hydrophilic. Average primary particle size is 21 nm.
		Aeroxide PF 2	Heat stabilizer for silicone	Sold as solid (10-kg bags). Mixture of titania and iron oxide.
		Aeroxide T 805	Sunscreens; Daily care products; Additive for toner	Sold as solid (20-kg bags). Treated with octylsilane (hydrophobic). Average primary particle size is 21 nm.
		Aeroxide TiO <sub>2</sub> NKT90	Toner	Sold as solid (10-kg bags). Treated with alkylsilane (hydrophobic).
		VP TiO <sub>2</sub> P 90	Catalyst and catalyst support; Photocatalyst; Heat stabilizer for silicone	Sold as solid (10-kg bags). Hydrophilic. Average primary particle size is 14 nm.
		Aerodisp W 740 X	Photocatalyst; Catalyst/catalyst carrier	Aqueous dispersion of hydrophilic Aeroxide (median particle size less than 100 nm). 60-kg containers; 220-kg drums; 1000-kg IBCs.
		VP Disp W 2730 X	Photocatalyst; Catalyst/catalyst carrier	Aqueous dispersion of hydrophilic TiO <sub>2</sub> (developmental) (median particle size less than 100 nm). 60-kg containers; 220-kg drums; 1000-kg IBCs.
NanoScale Corporation	Manhattan, KS	NanoActive Titanium Dioxide	Catalysts and catalyst supports; HAZMAT remediation; Destruction of chemical warfare agents; Paints and coatings; Protective apparel and personal	

Company	Potential Facility Locations	TiO <sub>2</sub> Product	Potential Applications	Notes
			protective equipment; Smoke removal; Structural ceramics; UV protecting clear coats	
BASF	Uncertain	T-Lite	UV protection for cosmetic applications	T-Lite is a line of products with rutile TiO <sub>2</sub> . Average particle length: 50 nm; width: 10 nm. Hydrophobic.
		Uvinul TiO <sub>2</sub>	UV protection for cosmetic applications	
Nano-Oxides, Inc.	Salt Lake City, UT	TiO <sub>2</sub> nanopowder	Cosmetics such as sunscreens; Photocatalysts for environmental purification; Catalyst support; Nanoporous membranes for filtration	Sold in quantities of 100, 250, and 500 g. Supplied as powders or liquid suspensions. Custom synthesizes nanomaterials per customer specifications.
Oxonica	Oxford, UK; Mountain View, CA	Optisol	Sunscreen formulations	
Tayca Corporation	Japan	MT-100TV		
Sachtleben	Finland	UV Titan M262		

---

### 5.1.1 *Manufacture of Nano-TiO<sub>2</sub> for Sunscreens*

Nano-TiO<sub>2</sub> is used in many sunscreen brands as an active UV blocker. In sunscreens, nano-TiO<sub>2</sub> may both absorb and scatter UV light to some degree. However, due to its smaller particle size than pigment grade TiO<sub>2</sub>, nano-TiO<sub>2</sub> absorbs more UV light than it scatters.

Sunscreen manufacturers require optimization of specific properties of nano-TiO<sub>2</sub>. These properties are determined and incorporated based on various steps during the manufacturing process. They include the following end-use properties<sup>1</sup>:

- High UV blocking (i.e., high SPF);
- Broad UV blocking (i.e., UV-A and UV-B blocking);
- Photostability; and
- Sunscreen opacity.

Nano-TiO<sub>2</sub> is naturally photocatalytic: the absorbance of UV light excites its electrons. The excited electrons may return to their ground state, emitting longer wavelength radiation, or escape from the particle. Escaped electrons may cause reactions in nearby molecules, which may generate free radicals. This is a potential concern because free radicals may cause further damage to skin cells or interact with other sunscreen components. The crystallinity of nano-TiO<sub>2</sub> affects photostability. In general, rutile is more photostable than anatase. However, anatase is still used in some sunscreen brands<sup>1</sup>.

Photostability of nano-TiO<sub>2</sub> is further increased with the use of surface coatings or doping. Surface coatings are added during the surface treatment phase of manufacture and can include:

- Silicon dioxide;
- Alumina;
- Other inorganic oxides;
- Dimethicone;
- Methicone;
- Lecithin;
- Stearic acid;
- Glycerol;
- Silica;
- Aluminum stearate;
- Dimethicone;
- Metal soap;
- Isopropyl titanium triisostearate;
- Triethoxy caprylylsilane; and
- C9-15 fluoroalcohol phosphate.

---

Doping involves embedding small amounts of metals directly into the nano-TiO<sub>2</sub> particles. Metals used in doping include<sup>1</sup>:

- Manganese;
- Vanadium;
- Chromium; and
- Iron.

### ***5.1.2 Manufacture of Nano-TiO<sub>2</sub> for Other UV Stabilizers***

Specific manufacturing requirements of nano-TiO<sub>2</sub> for other UV stabilizer applications have not been identified, including applications in plastic and textile products. However, limited information is available for DuPont's Light Stabilizer 210 (DLS). DLS is a rutile-phase TiO<sub>2</sub> with a median particle size range of 130 to 140 nm. Approximately 10 to 20 weight percent of the particles are less than 100 nm. DLS is surface coated to prevent the interaction of excited electrons with the surrounding matrix (e.g., the plastic product). DLS is surface treated with aluminum hydroxide, amorphous silica, and a silane, siloxane, or polyol for compatibility with the end-use system. It is manufactured as a solid powder and sold in plastic bags to a processor who incorporates the DLS into a "masterbatch" or polymer concentrate<sup>3</sup>.

### ***5.1.3 Manufacture of Nano-TiO<sub>2</sub> for Photocatalysts***

The majority of catalytic and photocatalytic applications of nano-TiO<sub>2</sub> for environmental remediation are under research and development or are only emerging uses. Information on the manufacture of nano-TiO<sub>2</sub> to produce catalysts or photocatalysts has not been identified.

Nano-TiO<sub>2</sub> is currently used as a photocatalyst in household applications, such as air filters, cleaning products, and self-cleaning coatings. Information has not been identified on the manufacturing methods or requirements for producing nano-TiO<sub>2</sub> applications; although, DuPont does note that most photocatalytic applications of TiO<sub>2</sub> use untreated anatase phases<sup>3</sup>.

## **5.2 Processing of Nano-TiO<sub>2</sub>**

This section discusses the specific processing requirements for nano-TiO<sub>2</sub> in each application. Table 5-4 provides a summary of identified nano-TiO<sub>2</sub> processors, their potential facilities, and their identified products. This list only presents the identified processors; additional processors may exist.

**Table 5-4. Nano-TiO<sub>2</sub> Processors, Facilities, and Identified Products**

Company	Potential Facility Locations	TiO <sub>2</sub> Product	Potential Applications
Kobo	South Plainfield, NJ	Sunscreen-ready nano-TiO <sub>2</sub> formulations	Sunscreen formulations
BASF	Uncertain	Ultramid BS 416N	Nylon fiber precursor imbedded with TiO <sub>2</sub> for clothing with UV protection
Croda	Mill Hall, PA; New Castle, DE	Solaveil CT-15W	Cosmetics
		Tioveil 50	Cosmetics
Strem Chemicals	Newburyport, MA	Titanium (IV) oxide nanopowder	Purchases, repackages and sells to research laboratories (academic, government, industry)

**5.2.1 Processing of Nano-TiO<sub>2</sub> for Sunscreens**

Most sunscreen applications are liquid based and, therefore, require nano-TiO<sub>2</sub> particles as a dispersion. Industrial contacts indicate that sunscreen formulators may directly purchase nano-TiO<sub>2</sub> powder and formulate a dispersion or they may purchase ready-made nano-TiO<sub>2</sub> dispersions prepared by a third party. Specific unit operations and processes regarding how nano-TiO<sub>2</sub> is dispersed for sunscreen applications have not been identified (multiple industrial contacts have noted this information is considered to be proprietary). However, some general processing steps are presented below.

Once nano-TiO<sub>2</sub> is dispersed into a sunscreen-ready dispersant, the dispersion is mixed with other sunscreen components. This process typically involves all liquid-based formulations that are heated and mixed. The resulting sunscreen formulation is then cooled and packaged<sup>30</sup>.

Nano-TiO<sub>2</sub> used for UV blocking in color cosmetic powders use a different process to produce the color cosmetic powder. The nano-TiO<sub>2</sub> is formulated into a powdered mixture. This powdered mixture is micropulverized and then sprayed with a liquid-based formulation. The resulting slurry is blended, micropulverized, and then pressed at high pressure to form the final color cosmetic powder<sup>30</sup>.

**5.2.2 Processing of Nano-TiO<sub>2</sub> for Other UV Stabilizers**

No information has been identified on the specific processing requirements of nano-TiO<sub>2</sub> for other UV stabilizer applications (e.g., plastics and textiles). DuPont provides limited information on processing their Light Stabilizer for plastic products. DLS is delivered as a solid powder in plastic bags to “masterbatch” or polymer concentrate facilities. These facilities prepare a polymer “carrier” that is used to form the masterbatch. The DLS is then added to an extruder via a hopper to blend the DLS with the polymer masterbatch. A melt extrusion process produces a polymer masterbatch that is well mixed and contains DLS on the order of 30 weight percent. Next, the extruded masterbatch is cooled and pelletized. Finally, these pellets are packaged for

---

shipment to polymer processing facilities that use the masterbatch to prepare a final plastic product<sup>3</sup>.

The polymer processor then blends the masterbatch with other polymer resin pellets in a melt process. The exact thermoplastic process can vary and is also considered proprietary; however, it can include:

- Extrusion;
- Injection molding;
- Thermoforming; and
- Rotational molding.

The resulting polymer blend, typically containing less than three weight percent DLS, can be processed into sheets, films, parts, fibers, or coatings<sup>3</sup>.

### ***5.2.3 Processing of Nano-TiO<sub>2</sub> for Photocatalysts***

A majority of catalytic and photocatalytic applications of nano-TiO<sub>2</sub> for environmental remediation are under research and development or are newly emerging uses. Information on the processing of nano-TiO<sub>2</sub> to produce catalysts or photocatalysts has not been identified and is considered proprietary.

Nano-TiO<sub>2</sub> is currently used as a photocatalyst in household applications, such as air filters, cleaning products, and self-cleaning coatings. It is additionally used in commercial remediation applications, such as decontamination. Information has not been identified on the processing methods or requirements for processing nano-TiO<sub>2</sub> for household photocatalytic and cleaning applications. It is likely that these products may require different processing methods. For example, liquid-based self-cleaning coatings may require that the nano-TiO<sub>2</sub> be processed into a suspension. On the other hand, photocatalytic air filters may require that the nano-TiO<sub>2</sub> be coated onto a solid filter media. Laboratories or HAZMAT emergency response teams may use remediation products as a solid powder.

## **5.3 Use of Nano-TiO<sub>2</sub>**

The rise in issues of emerging environmental and health concerns stem from the various commercial applications of nano-TiO<sub>s</sub>. These uses are described in the following subsections.

### ***5.3.1 Use of Nano-TiO<sub>2</sub> in Sunscreens***

Nano-TiO<sub>2</sub> is used as a UV blocker in various sunscreen applications<sup>6,30</sup>. The widest use of nano-TiO<sub>2</sub> as a sunscreen in consumer products identified is in personal care sunscreens. These sunscreens are applied to human skin to provide UV protection. Sunscreens are widely used in the United States for reducing UV exposure during outdoor activities. Some cosmetic products also use nano-TiO<sub>2</sub> to provide UV protection<sup>6,30</sup>.

Sport performance clothing also uses nano-TiO<sub>2</sub> to provide UV protection. In this application, nano-TiO<sub>2</sub> is imbedded within the clothing fibers<sup>6</sup>.

---

### **5.3.2 Use of Nano-TiO<sub>2</sub> as Other UV Stabilizers**

Nano-TiO<sub>2</sub> is used as a UV stabilizer or blocker in products other than sunscreens, such as plastic products and textiles. In these applications, the nano-TiO<sub>2</sub> protects both the matrix and the material behind the matrix (such as a product within a plastic container) from degradation due to UV light. These market applications are dominated by organic UV stabilizers<sup>3</sup>. At this time, it is uncertain to what extent nano-TiO<sub>2</sub> has penetrated this UV stabilizer market. However, at least one product is commercially available and has been advertised for this use.

The UV stabilizer is typically present within the matrix at less than three weight percent. Many polymer types use UV stabilizers including<sup>3</sup>:

- Polypropylene;
- Polyethylene;
- Acrylonitrile-butadiene-styrene copolymer (ABS);
- Polystyrene;
- Polycarbonate; and
- PVC.

Examples of products that use UV stabilizers include<sup>3</sup>:

- Automotive interior paints;
- Sporting goods;
- Packaging such as shampoo bottles and drink bottles;
- Agricultural films;
- Fabrics and clothing; and
- Outdoor furniture.

### **5.3.3 Use of Nano-TiO<sub>2</sub> as Photocatalysts**

Nano-TiO<sub>2</sub> is used in various applications for its photocatalytic properties. In these applications, in the presence of light, it catalyzes the degradation or other reaction of undesired chemicals or microorganisms. Multiple consumer products that use nano-TiO<sub>2</sub> as a photocatalyst have been identified; however, the extent to which these products have penetrated the U.S. market is unknown. Commercial applications have been identified; these commercial applications include remediation and decontamination of chemicals and biological agents. Similarly as with consumer products, the extent to which these commercial products have penetrated the U.S. market is unknown.

One specific consumer application of photocatalytic nano-TiO<sub>2</sub> is in air filtering applications. Carrier produces an air filter that uses nano-TiO<sub>2</sub> to provide antibacterial properties. Hitachi produces a refrigerator that uses a filter coated with nano-TiO<sub>2</sub> to purify the air that is recirculated within the refrigerator<sup>6</sup>.

There are multiple self-cleaning coatings that use nano-TiO<sub>2</sub> currently available on the market. For example, Bio Shield, Inc. markets a product (NuTiO) that is a liquid-based self-cleaning

---

coating that contains a suspension of nano-TiO<sub>2</sub>. Bio Shield, Inc. claims that NuTiO can be coated onto any surface to provide a self-cleaning coating that will last up to ten years before reapplication. The product is claimed to photocatalyze naturally present water and oxygen in the air into hydroxyl and superoxide anions. These anions are claimed to oxidize and decompose toxic and odorizing organic chemicals and bacteria present in the air. Bio Shield, Inc. markets this product for household applications as well as for commercial and institutional settings (such as in the food industry and schools, respectively). Similar products with similar claims include nanoCotz, Ionic Zone's Nano TiO<sub>2</sub> PCO Liquid, T-2, and Air Cleaner Medium by Shenzhen. Only T-2 provided application instructions through its website: T-2 is sold in a spray bottle and is spray applied onto surfaces<sup>6</sup>.

NuTiO is claimed to be manufactured in the U.S. and is marketed by a U.S.-based company. T-2 and Nano TiO<sub>2</sub> PCO Liquid are also marketed by U.S.-based companies. NanoCotz is marketed by the Singapore company Inspiraz Technology Pte Ltd, and Shenzhen is based in China. It is uncertain as to the extent these products are used within the U.S.

Some hair styling devices also use nano-TiO<sub>2</sub> for antibacterial properties. For example, FHI produces hair dryers, flat irons, and curling irons using their Nano-Fuzeion technology. This technology uses nano-TiO<sub>2</sub>, nano-titanium, and nano-silver. FHI claims the nano-TiO<sub>2</sub> removes chemical pollutants and unwanted matter from the user's hair<sup>6</sup>.

This review identified computer hardware devices that use nano-TiO<sub>2</sub>, along with nano-silver, to provide antibacterial properties. For example, IOGEAR's nano-TiO<sub>2</sub> and nano-silver coated computer keyboards and mouse are claimed to deactivate enzymes and proteins to deactivate bacteria, fungi, and algae on the surface of the device<sup>6</sup>.

## **5.4 End of Life**

This section presents an overview of the end of life of nano-TiO<sub>2</sub> for each application.

### **5.4.1 *End-of-Life of Sunscreens***

The end-of-life of sunscreens includes the discarding of sunscreen containers by consumers. Discarded containers contain residual sunscreen, which in turn contains nano-TiO<sub>2</sub>. Eriksson et al.<sup>31</sup> cite work performed by Plagellat et al. who estimate that 10 percent of sunscreens remain in the packaging. This 10 percent residual estimate is based on a study conducted in Switzerland. The residual fraction of sunscreens within their containers depends on specific human behavior as well as the shelf-life of the sunscreen. It is uncertain if this 10 percent residual estimate is applicable to sunscreen activities within the U.S.

Mueller and Nowack<sup>32</sup> conduct exposure modeling of nano-TiO<sub>2</sub> in Switzerland. In their modeling, the authors estimate that 5 percent of cosmetics are released as residual during container disposal. It is uncertain if the authors' categorization of "cosmetics" includes sunscreens. Similarly as with sunscreens, the residual fraction of cosmetics within their containers depends on specific human behavior as well as the shelf-life of the cosmetic. It is uncertain if this 5 percent residual estimate is applicable to cosmetic activities in the U.S.

---

#### ***5.4.2 End-of-Life of Other UV Stabilizers***

The end-of-life of products that use nano-TiO<sub>2</sub> UV stabilizers described in Section 5.3.2 includes the discarding of the products after use. A majority of the products that potentially use nano-TiO<sub>2</sub> UV stabilizers are consumer products. Therefore, the end-of-life of these products would include disposal as municipal solid waste (MSW) or recycling. However, Section 5.3.2 also identified a potential use as agricultural films. It is uncertain if agricultural films refer to films used in agricultural settings or films used to wrap consumer agricultural food products. Food product films would likely be discarded by consumers after use to MSW. The end-of-life of films used strictly in agricultural settings is uncertain.

Mueller and Nowack<sup>32</sup> estimate that 95 percent of plastics containing nano-TiO<sub>2</sub> are collected as solid waste. The authors estimate that the remaining 5 percent of the plastics are released during the life of the product from abrasion. However, the basis of the 5 percent abrasion estimate was not provided.

#### ***5.4.3 End-of-Life of Photocatalysts***

The end-of-life of household and commercial products that use photocatalytic nano-TiO<sub>2</sub> may vary with each specific product. A majority of the products discussed in Section 5.3.3 are consumer products. Therefore, the end-of-life of these products would include disposal as MSW or recycling. However, some of the identified products may have commercial applications. For example, the self-cleaning coatings may be applied within commercial settings. It is uncertain exactly how commercial applications may be discarded or recycled.

Mueller and Nowack<sup>32</sup> estimate that 95 percent of coatings that contain nano-TiO<sub>2</sub> are applied to substrates and the remaining 5 percent are disposed of as residual in containers. However, the basis of the 5 percent residual estimate was not provided.

---

## 6. EXPOSURE PATHWAYS

This section discusses the exposure pathways of nano-TiO<sub>2</sub> to the environment, to workers, and to the general population. This section specifically addresses the following components of an exposure pathway as defined by the Agency for Toxic Substances & Disease Registry (ATSDR):

- Exposure source;
- Transport mechanism;
- Point of exposure;
- Route of exposure; and
- Receptor population.

### 6.1 Exposure Sources

Section 6.1 and the following subsections outline potential release and exposure sources throughout the life cycle of nano-TiO<sub>2</sub> for each use.

#### 6.1.1 *Manufacturing*

The manufacture of nano-TiO<sub>2</sub> results in multiple environmental exposure sources due to process releases, as described and estimated in Table 6-1. These release estimates assume the nano-TiO<sub>2</sub> manufacturer collects the nano-TiO<sub>2</sub> as a solid powder from the production line and then repackages the nano-TiO<sub>2</sub> for sale. It is conservatively assumed that the nano-TiO<sub>2</sub> is sold as a solid powder without further formulation into liquid (exposure to powder forms results in formation of fugitive dusts and corresponding dermal and inhalation exposures).

Table 6-1 summarizes the potential release sources and associated quantities. The exact environmental media to which nano-TiO<sub>2</sub> is released depends on the waste handling and clean-up practices employed by the manufacturer. The quantity of dust emissions to air from handling and packaging solid powders depends on the air pollution control devices employed. The facility's practices for cleaning equipment, cleaning or disposing of spent containers, and handling spills are determinants of the environmental emissions to other media. For example, cleaning conducted with water and released to the facility's wastewater stream may introduce nano-TiO<sub>2</sub> into the wastewater. However, if a facility handles waste streams that potentially contain nano-TiO<sub>2</sub> as non-hazardous solid waste or as hazardous waste, then introductions to water would be less likely. Actual industrial practices employed by individual manufacturers are uncertain. Therefore, the release estimates and environmental media presented in Table 6-1 are based on EPA Office of Pollution Prevention and Toxics (OPPT) conservative models that are used when site-specific data are not available.

Table 6-1 also summarizes potential engineering controls used for each activity. These engineering controls are described by DuPont in their submission to the EPA Nanoscale Materials Stewardship Program (NMSP) for their Light Stabilizer production process<sup>3</sup>. However, it is uncertain if these engineering controls are applicable to other U.S. nano-TiO<sub>2</sub> manufacturers or for the production of nano-TiO<sub>2</sub> for applications other than UV stabilizers for plastics.

**Table 6-1. Summary of Process Releases of Nano-TiO<sub>2</sub> to Environmental Media During Manufacturing**

Potential Environmental Media <sup>1</sup>	Daily Release Rate (wt% of daily through-put) <sup>1</sup>	Release Frequency (days/year) <sup>1</sup>	Activity	Potential Engineering Controls <sup>2</sup>	Release Basis <sup>1</sup>
Air (non-captured emissions); Water or Incineration or Landfill (captured emissions)	0.5%	250	Transferring solid nano-TiO <sub>2</sub> from product collector to packaging mechanism.	Automatic packing machines. Dust collectors. Baghouse with 99.98% efficiency. 0.02% to air. 99.98% to water or landfill.	EPA/OPPT Dust Emissions from Solids Transfers Model estimates 0.5% of the solids transferred are released as dust emissions to uncertain media.
Water (non-captured aqueous releases); Incineration or Landfill (captured aqueous releases or solid or hazardous waste)	1%	250	Cleaning solid nano-TiO <sub>2</sub> residuals (powders) in process vessels.	On-site wastewater treatment with flocculation. 99.3% removal efficiency. 99.3% to landfill / recycle. 0.7% pass through to surface water.	EPA/OPPT Solid Residuals in Process Vessels Model estimates 1% residual in process vessels.
Incineration or Landfill	1%	250	Cleaning or discarding lining from product collector container.	Landfill	EPA/OPPT Solid Residuals in Transport Containers Model estimates 1% residual remains in emptied containers.

<sup>1</sup> Values estimated using EPA/OPPT models.

<sup>2</sup> Data obtained from DuPont's NMSP submission<sup>3</sup>.

---

### **6.1.2 Processing**

The exposure sources resulting from the processing of nano-TiO<sub>2</sub> will vary with each application depending on the specific unit operations that are involved. Activities generating environmental releases may be expected to be similar to those observed during manufacturing. If processors receive nano-TiO<sub>2</sub> from manufacturers as solid powders, then the processors may expect dust emissions from handling the solid powder as well as solid residuals in the shipping containers. The processors may further expect solid residuals in any equipment used to process the solid powders.

Many of the applications discussed in Section 5.3 require nano-TiO<sub>2</sub> to be formulated into a liquid suspension or polymer resin. In these applications, processors may expect potential environmental releases of nano-TiO<sub>2</sub> contained in liquid or solid resin releases.

Table 6-2 summarizes the potential sources and quantities of process releases and their respective environmental media. Similarly as with manufacturing, the exact environmental media to which nano-TiO<sub>2</sub> is released depends on the waste handling and clean-up practices employed by the processor. Facilities may employ air pollution control devices to control dust emissions to air. Facilities' practices for cleaning equipment, cleaning or disposing of spent containers, and handling spills may also vary. For example, cleaning conducted with water and released to the facility's wastewater stream may introduce nano-TiO<sub>2</sub> into the wastewater. If a facility handles waste streams that potentially contain nano-TiO<sub>2</sub> as non-hazardous solid waste or as hazardous waste, then introductions to water would be less likely. Similarly as with manufacturing, the actual industrial practices employed by processors are uncertain; therefore, the release estimates and environmental media presented in Table 6-2 are based on EPA Office of Pollution Prevention and Toxics (OPPT) conservative models that are used when site-specific data are not available. Information on potential engineering controls used by processing facilities has not been identified.

**Table 6-2. Summary of Process Releases of Nano-TiO<sub>2</sub> to Environmental Media During Processing**

Potential Environmental Media <sup>1</sup>	Daily Release Rate (wt% of daily through-put) <sup>1</sup>	Release Frequency (days/year) <sup>1</sup>	Activity	Release Basis <sup>1</sup>
Air (non-captured emissions); Water or Incineration or Landfill (captured emissions)	0.5%	250	Unloading nano-TiO <sub>2</sub> from packaging and charging hopper or other process vessel.	EPA/OPPT Dust Emissions from Solids Transfers Model estimates 0.5% of the solids transferred are released as dust emissions to uncertain media.
Water (non-captured aqueous releases); Incineration or Landfill (captured aqueous releases or solid or hazardous waste)	1%	250	Cleaning solid nano-TiO <sub>2</sub> residuals in process vessels.	EPA/OPPT Solid Residuals in Process Vessels Model estimates 1% residual in process vessels..
Incineration or Landfill	1%	250	Cleaning or discarding product packaging.	EPA/OPPT Solid Residuals in Transport Containers Model estimates 1% residual remains in emptied containers.
Water (non-captured aqueous releases); Incineration or Landfill (captured aqueous releases or solid or hazardous waste)	2%	250	Cleaning liquid residuals containing nano-TiO <sub>2</sub> from process vessels.	EPA/OPPT Multiple Process Vessel Residual Model estimates 2% residual from multi-vessel and other equipment processes.

<sup>1</sup> Values estimated using EPA/OPPT models.

### 6.1.3 Use

The exposure sources during the use of nano-TiO<sub>2</sub> are expected to vary with each application. The following subsections describe potential exposure sources that may occur during each application discussed in Section 5.3.

#### 6.1.3.1 Sunscreens

The use of sunscreens or cosmetics containing nano-TiO<sub>2</sub> is a direct exposure source of nano-TiO<sub>2</sub>. This application requires a person to apply the nano-TiO<sub>2</sub>-based product directly onto their skin. The use of these products is a source of dermal exposures to nano-TiO<sub>2</sub>.

Users of sunscreens or cosmetics may enter surface water bodies such as oceans, lakes, or rivers. The washing off of these products provide a source of nano-TiO<sub>2</sub> to surface waters. Remaining TiO<sub>2</sub> could be introduced to water systems when the user bathes. In this scenario, these sunscreen products also provide a source of nano-TiO<sub>2</sub> from wastewater streams.

---

In their exposure modeling, Mueller and Nowack<sup>32</sup> estimate that, of all cosmetics applied to users, 100 percent is eventually released to water. The authors estimate that 95 percent of this release is sent to a wastewater treatment plant. The remaining 5 percent of this release is released to untreated waters. However, this exposure modeling scenario was conducted for Switzerland, and it is uncertain if these release estimates are applicable to the U.S.

#### **6.1.3.2 Other UV Stabilizers**

The applications of nano-TiO<sub>2</sub> as a UV stabilizer discussed in Section 5.3.2 present limited exposure sources during use. These applications all require nano-TiO<sub>2</sub> to be formulated and entrained within a plastic or textile product. Direct exposure to nano-TiO<sub>2</sub> during normal use may be limited. However, additional research is required to understand the transport potential of nano-TiO<sub>2</sub> from its respective matrix if the product suffers from excessive wear or breakage or is exposed to different environmental media.

Mueller and Nowack<sup>32</sup> estimate that, during their use, 5 percent of plastic products containing nano-TiO<sub>2</sub> are released to the environment from abrasion. Of this 5 percent released from abrasion, the authors estimate that 50 percent is released to air and 50 percent is released to wastewater treatment plants. However, the basis of these estimates was not provided.

#### **6.1.3.3 Photocatalysts**

The applications of nano-TiO<sub>2</sub> as a photocatalyst discussed in Section 5.3.3 present multiple exposure sources during use. The exact exposure sources are expected to vary with each application.

NanoScale Corporation markets multiple products for remediation and decontamination applications for commercial and academic laboratories, HAZMAT emergency response teams, and the military<sup>7</sup>. These products include both solid powder and liquid-based forms. Although it is uncertain which specific products include nano-TiO<sub>2</sub>, NanoScale markets their TiO<sub>2</sub> for self-cleaning, remediation, and decontamination applications. Therefore, laboratory workers, HAZMAT emergency response team members, and military personnel may be exposed to nano-TiO<sub>2</sub> through solid powder or liquid-based forms when responding to spills or other contaminations.

The self-cleaning coatings potentially pose the most significant exposure source to consumers of the applications discussed in Section 5.3.3. Self-cleaning coatings require consumers to directly handle a liquid-based dispersion of nano-TiO<sub>2</sub>. The application methods vary among brush and spray applications, and consumers may expect both dermal and inhalation exposure sources during application. Consumers are likely exposed to the final dried coating on the household items on a daily basis. The exposure potential to nano-TiO<sub>2</sub> within the dried coating varies with use patterns. For example, a coated high-traffic floor may receive excessive wear. Research is required to determine if such wear may increase consumers' exposure to nano-TiO<sub>2</sub>.

Additional applications also present daily exposure sources to consumers. Nano-TiO<sub>2</sub> used on computer hardware devices and hair styling devices present daily exposure sources to

---

consumers. Both of these applications use nano-TiO<sub>2</sub> coated on a surface of the product, which consumers directly contact during use. However, research is required to understand and quantify the potential dermal exposure from these devices. Such exposure potential may be affected by the method used to coat the nano-TiO<sub>2</sub> onto the device.

Sportswear using nano-TiO<sub>2</sub> presents multiple exposure sources. First, consumers may be exposed to nano-TiO<sub>2</sub> imbedded within the fibers of the clothing through dermal contact during use. Second, the clothing may release nano-TiO<sub>2</sub> from within its fibers during washing. This release would present an exposure source of nano-TiO<sub>2</sub> to the wastewater stream.

The final application discussed is the use of nano-TiO<sub>2</sub> in air filter devices. Although consumer exposures may not be expected during normal use, it is possible exposures may result from maintenance or repair activities.

Although exposure sources are expected to vary by application, modeling results by Mueller and Nowack<sup>32</sup> provide an overall release estimate associated with the use of photocatalysts. The authors estimate that of all applied coatings containing nano-TiO<sub>2</sub>, 95 percent is eventually released to wastewater treatment plants. The remaining 5 percent is released to air, presumably through abrasion of the coating. The basis of these estimates is not provided.

#### ***6.1.4 End-of-Life of Consumer Products***

The end-of-life of consumer products includes disposal of these products by consumers. These discarded products, which contain nano-TiO<sub>2</sub> in some form, present an exposure source to multiple exposure pathways. The exact pathways and relative amount of nano-TiO<sub>2</sub> released to each pathway depends on the exact product discarded and the municipal solid waste (MSW) handling practices employed. The U.S. EPA estimates that, in 2008, the U.S. generated approximately 250 million tons of MSW. Of these 250 million tons, approximately 33 percent were recovered through recycling or composting, 13 percent were combusted for energy recovery, and the remaining 54 percent were discarded to landfills<sup>33</sup>. These three end-of-life scenarios (recycling, incineration, and landfill) result in different exposure pathways as discussed below.

#### **Recycling**

The exposure pathways presented by recycling depend on the exact product recycled. Recycled sunscreen or self-cleaning coating containers may be washed to remove residual product prior to recycling. This washing step may introduce sunscreen or self-cleaning coating containing nano-TiO<sub>2</sub> into the wastewater treatment system. If the recycled product itself contains nano-TiO<sub>2</sub>, such as a plastic product that uses a nano-TiO<sub>2</sub> UV stabilizer, then the nano-TiO<sub>2</sub> would be recycled along with the recycled resin. It is not certain if steps are taken to determine if nano-TiO<sub>2</sub> is contained in recycled resins at the point in which they are blended to produce a post-consumer-waste product. It is not certain if recycled resins that contain nano-TiO<sub>2</sub> are used in applications where additional nano-TiO<sub>2</sub> UV stabilizer is added such that an accumulation of nano-TiO<sub>2</sub> may develop.

---

## **Incineration**

An incineration end-of-life scenario presents multiple exposure pathways. Nano-TiO<sub>2</sub> incinerated in discarded products is emitted in the incinerator exhaust or in the incinerator residual ash. If emitted in the incinerator exhaust, it is uncertain if the TiO<sub>2</sub> would enter the air or be removed via air pollution control devices, which can include scrubbers or filters<sup>34</sup>. If the TiO<sub>2</sub> remains in the incinerator ash, then the exposure pathway of TiO<sub>2</sub> would depend on the fate of the incinerator ash. The U.S. EPA estimates that approximately 10 percent of incinerator ash is used as landfill cover or in road construction<sup>34</sup>. Therefore, the exposure pathway of nano-TiO<sub>2</sub> from incineration depends on the following:

- The fate and transport of nano-TiO<sub>2</sub> during incineration, including;
  - Transport to the gaseous medium;
  - Transport to the ash medium;
- The method used to control the incineration media, including;
  - Scrubbers;
  - Filters;
  - Land applying ash;
- The fate and transport of nano-TiO<sub>2</sub> within the media control technology, including;
  - The fate and transport within the scrubber;
  - The fate and transport within the filter; and
  - The fate and transport within the specific land application.

DuPont discusses the fate and transport of TiO<sub>2</sub> in municipal incinerators<sup>3</sup>. The TiO<sub>2</sub> is not expected to thermally degrade within the incinerator. It is estimated that approximately 50 percent of TiO<sub>2</sub> in an incinerator is entrained in the offgas and transported to the fly ash. The remaining 50 percent is included with residual solids remaining in the bottom ash. DuPont estimates that most municipal incinerators are equipped with particulate controls (such as baghouses and electrostatic precipitators) that would capture some or all of the TiO<sub>2</sub> in the fly ash; a quantitative estimate of efficiency was not provided.

Mueller and Nowack<sup>32</sup> estimate “realistic-emission” and “high-emission” scenarios of the fate and transport of incombustible nano-TiO<sub>2</sub> in incineration plants. The authors estimate that 50 percent of the nano-TiO<sub>2</sub> is transported to the incinerator exhaust under the realistic-emission scenario. Under the high-emission scenario, 100 percent of the nano-TiO<sub>2</sub> is transported to the exhaust. The remainder of the nano-TiO<sub>2</sub> not transported to the exhaust remains as residual in the slag or ash. The authors further estimate a control efficiency of the exhaust filters of 99 to 99.9 percent. The remaining 0.1 to 1 percent is ultimately released into the air. Note that a basis for these estimates was not provided.

## **Landfill**

Nano-TiO<sub>2</sub> enters landfills through the discarding of consumer products containing nano-TiO<sub>2</sub>. The fate and transport of nano-TiO<sub>2</sub> within a landfill depends on the exact type of discarded product. For example, discarded sunscreen bottles with residual sunscreen containing nano-TiO<sub>2</sub> may pose a different mechanism of introducing nano-TiO<sub>2</sub> into the landfill than a plastic product

---

containing nano-TiO<sub>2</sub> UV stabilizer. The fate and transport mechanisms may further differ for products that contain a nano-TiO<sub>2</sub>-based coating, such as computer hardware parts, hair styling devices, or any household item in which a consumer applied a self-cleaning coating. The use of self-cleaning coatings further complicates the study of the fate and transport of nano-TiO<sub>2</sub> in landfills. Since consumers may apply self-cleaning coatings to a number of products, there is an increased uncertainty as to which products within a landfill may contain nano-TiO<sub>2</sub>.

## **6.2 Transport Mechanisms**

The transport mechanisms of nano-TiO<sub>2</sub> in various environmental media are: 1) surface water; 2) groundwater; 3) soil; and 4) air. Each mechanism is discussed in more detail in subsections 6.2.1 through 6.2.4.

### **6.2.1 *Transport Mechanisms in Surface Water***

The transport potential of nano-TiO<sub>2</sub> in surface water is an important segment of the exposure pathway. As discussed in Section 6.1, multiple nano-TiO<sub>2</sub> exposure sources to surface water exist, particularly from the use of sunscreens and cosmetics.

In general, the colloidal stability and extent of aggregation of nanoparticles in water will greatly impact the transport potential of the nanoparticles. The colloidal stability can be a function of the pH and ionic strength of the water and the physical and chemical properties of the nanoparticle of interest. Interactions between the nanoparticles and natural and anthropogenic chemicals in the system, along with biological and abiotic processes, further control the transport of nanoparticles in aqueous environments<sup>35</sup>.

Schmidt and Vogelsberger<sup>36</sup> studied the solubility of industrially-produced nanostructured TiO<sub>2</sub> in aqueous sodium chloride solutions of pH 1 to 13. The authors investigated the long-term solubility (dissolution time greater than 500 hours) at 25 °C. The studied nanoparticles included phase compositions of anatase, anatase and rutile mixtures, and anatase and amorphous mixtures. The mean calculated particle diameters ranged from 4.7 to 28.3 nm. The reported solubility was on the order of 1 nmol/L in the pH range of 3 to 11. As pH decreased below three, the solubility increased as high as 1 to 2 μmol/L at a pH of one. The solubility of the nanoparticles showed little variation between most of the different particle sizes. The smallest particle sample, the 4.7-nm pure anatase particles, showed a higher solubility. The authors noted that, in general, an amorphous particle with a highly hydroxylated surface will have a higher solubility than a highly-crystalline particle. The authors also noted the following parameters may impact solubility and should be reported in solubility studies:

- Dissolution time;
- Primary particle size; and
- Hydroxylation and hydration of the solid phase.

Guzman et al.<sup>37</sup> investigated the effect of pH on the aggregation of nano-TiO<sub>2</sub> in water and transport in porous media. The experiments showed that pH and aggregate size control the

---

interactions between the TiO<sub>2</sub> aggregates and other nanoparticles or water. Approximately 80 percent of suspended particles and aggregates were mobile in the pH range of 1 to 12.

Chen et al.<sup>38</sup> studied the transport of manufactured nano-TiO<sub>2</sub> in unsaturated porous media. Specifically, the authors investigated the retention of the nano-TiO<sub>2</sub> in the air-water interface during primary drainage (i.e., drying) of water from an initially saturated porous medium. For this study, the authors used industrially-produced nano-TiO<sub>2</sub> with a nominal particle size of 21 nm. The authors prepared stable aqueous suspensions of the nano-TiO<sub>2</sub> and observed that the nano-TiO<sub>2</sub> existed in suspension as stable clusters with particle sizes of approximately 123 ± 7.6 nm. The study used a simulated soil column made from glass beads. Results suggested that for water transport occurring above the water table, TiO<sub>2</sub> accumulation may be more significant because the nanoparticles are more likely to be trapped in the air-water interface. As water level recedes, these particles remain trapped in water films at the soil surface. Results also suggested that this phenomenon does not exist for water transport occurring below the water table.

Several research projects have been identified that study the fate and transport of nano-TiO<sub>2</sub> in wastewater treatment plants. Kiser et al.<sup>39</sup> sampled a wastewater treatment plant (WWTP) in Arizona, U.S. during the month of June 2008 with additional sampling in January 2009. The studied WWTP used an activated sludge process and tertiary filtration treatment. The authors obtained additional samples from confidential WWTPs in Arizona, California, Colorado, Iowa, Maryland, and New York. The authors confirmed the presence of TiO<sub>2</sub>, as Ti, in the WWTP influent water. Average concentrations of Ti in the influent water ranged from 185 to as high as 2800 µg Ti/L. The 2800 µg Ti/L sample was statistically different from other samples taken at the same location at different times. The authors speculated that this spike in influent Ti concentration may have been due to an industrial source. The authors found an overall removal efficiency of Ti of 82 ± 21% for the Arizona WWTP studied in June 2008 and January 2009. The concentration of Ti in the effluent water ranged from 10 to 100 µg/L. Although the WWTP showed a relatively high removal of Ti (82 ± 21%), the authors noted that the tendency for Ti to adsorb to the biosolid phase was important as biosolids are land applied as fertilizers, incinerated, disposed to landfills, and used in other applications. Therefore, TiO<sub>2</sub> may enter environmental media through biosolid accumulation.

Brar et al.<sup>35</sup> discussed general concepts and concerns of the fate and transport of nanoparticles in wastewater treatment plants. The authors suggested that nanoparticles present in higher concentrations may impact the performance of waste treatment processes by various mechanisms. These impacts may include inhibiting microorganisms in secondary treatment, increasing turbidity, fouling membranes, and affecting the efficiency of disinfection processes.

### **6.2.2 *Transport Mechanisms in Groundwater***

Nano-TiO<sub>2</sub> releases to the environment, particularly landfill media, carry the potential for migration to groundwater aquifers. For this reason, it is necessary to consider TiO<sub>2</sub> mobility through porous media.

Lecoanet et al.<sup>40</sup> studied the mobility of nano-TiO<sub>2</sub> to assess the potential for migration in porous media. The nanoparticles employed in this study were anatase phase crystals with average

---

particle and aggregate sizes of 40 nm and 198 nm, respectively. Particle concentrations ranging from 0 mg/L to 10 mg/L were introduced into the flow stream just before entering a porous column containing glass beads. The flow stream was a buffered water solution that modeled the pH and ionic strength representative of freshwater aquifers. The breakthrough curves obtained for nano-TiO<sub>2</sub> showed that the travel distance required to reduce the initial anatase TiO<sub>2</sub> nanoparticle concentration down to 0.1% was 10 cm. The authors believed that this short distance was indicative of an affinity of the TiO<sub>2</sub> nanoparticles for the porous medium, suggesting that the groundwater migration of TiO<sub>2</sub> nanoparticles in the environment is limited. The authors noted, however, that the passage of these nanoparticles will creep upward with time as deposition sites in the porous medium become saturated, thereby allowing migration over larger distances.

### ***6.2.3 Transport Mechanisms in Soil***

Understanding the transport of nanoparticles in soil requires knowledge of the nanoparticles' partitioning between the solid (soil) and liquid (water) phases. In general, the tendency for substances to partition from water to soil or sediment depends upon the hydrophobic characteristics of the substance and the properties of the solid media to which it will adsorb. Partitioning can occur via covalent and ionic bond formation as well as through electrostatic adsorption. Surfactants, which are commonly used with engineered nanoparticles to aid in dispersions, might also affect the partitioning; therefore, the presence of a surfactant should be noted in a study to help fully inform the reader. For example, natural organic carbon (NOC) can act as a natural surfactant and researchers have found some evidence that NOC coatings can help stabilize some aqueous nanomaterial dispersions.

As discussed in Section 6.1, many end-of-life consumer products containing nano-TiO<sub>2</sub> are expected to be discarded in landfills. From these releases, a potential exists for the disposed nano-TiO<sub>2</sub> to migrate into groundwater. The rate of the release would then depend on the products' specific partitioning characteristics. For this reason, it is necessary to understand the transport behavior of nano-TiO<sub>2</sub> when suspended in soils.

Fang et al.<sup>41</sup> studied the transport behavior of suspended TiO<sub>2</sub> nanoparticles through soil columns saturated with water. The nanoparticles employed in this study were anatase phase crystals with an average particle size of 35 nm. The results of this study showed that TiO<sub>2</sub> could remain suspended in soil throughout the duration of the experiment (10 days). Soils with high clay content and salinity were observed to retain nano-TiO<sub>2</sub> to a more significant extent. Maximum travel distances ranged from 11.1 cm to 370 cm, indicating potential environmental risk of TiO<sub>2</sub> to deep soil layers. The authors also observed that the size distribution of the nano-TiO<sub>2</sub> aggregates in the suspension changed over time. The initial aggregate size distribution was 0.34 to 7.1 μm; however, by the tenth day the suspended aggregates measured 0.04 to 0.35 μm. The authors attributed this change to preferential settling of the larger aggregates within the solution, leaving behind the smaller aggregates. TiO<sub>2</sub> suspension concentrations correlated positively with dissolved organic carbon and clay content and correlated negatively with suspension ionic strength, zeta potential, and pH.

---

#### **6.2.4 *Transport Mechanisms in Air***

TiO<sub>2</sub> nanoparticles are likely to be transported into the air during manufacture (as fugitive particle emissions) or during incineration of discarded nano-TiO<sub>2</sub>-containing consumer products. Compared to other release media, nano-TiO<sub>2</sub> transport into air is not expected to be as significant in scale. Material flow modeling results by Gottschalk et al.<sup>42</sup> estimated that 0.24 tonnes/yr to 0.264 tonnes/yr enter the air compartment from manufacturing, waste incineration, and soil erosion sources. This estimate is less significant compared to other release media such as water (3.59 tonnes/yr to 5.05 tonnes/yr) and landfill (26.78 tonnes/yr to 29.42 tonnes/yr). Once suspended, the model estimates that nano-TiO<sub>2</sub> will settle at a rate of 0.23 tonnes/yr to 0.26 tonnes/yr. Travel distances once suspended in air were not estimated.

#### **6.3 Points and Routes of Exposure**

The potential points and exposure to nano-TiO<sub>2</sub> are explored and defined via dermal, inhalation and ingestion routes in subsections 6.3.1 through 6.3.3.

##### **6.3.1 *Dermal Exposures***

Workers in occupational settings experience dermal exposures to nano-TiO<sub>2</sub>. Dermal exposures result from the handling of solid powders and liquids containing nano-TiO<sub>2</sub>.

The general population can experience dermal exposures to nano-TiO<sub>2</sub> through multiple applications. Sunscreens and similar cosmetics are the most prevalent source of dermal exposures. However, individuals may also experience dermal exposures through the use of products coated with nano-TiO<sub>2</sub>. These products include computer hardware devices such as mice and consumer-applied self-cleaning coatings.

##### **6.3.2 *Inhalation Exposures***

Workers in occupational settings additionally experience inhalation exposures to nano-TiO<sub>2</sub>. Inhalation exposures result from dust emissions from solid powders or from mists generated from spraying coatings containing nano-TiO<sub>2</sub>.

The general population can experience inhalation exposures to nano-TiO<sub>2</sub> from mist generated during spray application of self-cleaning coatings. One consumer self-cleaning coating currently on the market has been confirmed to use a spray bottle application. Additionally, sunscreens are now developed that can be spray applied (although no such TiO<sub>2</sub>-specific sunscreens were identified).

##### **6.3.3 *Ingestion Exposures***

Individuals may be exposed to nano-TiO<sub>2</sub> through the ingestion of drinking water. As discussed in Section 6.1, nano-TiO<sub>2</sub> is expected to be released to surface water bodies and wastewater treatment systems. Both of these pathways have the potential to introduce nano-TiO<sub>2</sub> into drinking water supplies. Nano-TiO<sub>2</sub> may be further introduced into the delivered drinking water

---

depending on its fate and transport within a drinking water plant. Further research is required to determine if nano-TiO<sub>2</sub> is transported into drinking water supplies from these facilities.

#### **6.4 Receptor Populations**

Three receptor populations are exposed to nano-TiO<sub>2</sub>:

- Occupational workers who handle nano-TiO<sub>2</sub> or nano-TiO<sub>2</sub>-enhanced products;
- Consumers who use nano-TiO<sub>2</sub>-enhanced products in their homes; and
- Individuals of the general population.

Occupational workers are exposed to nano-TiO<sub>2</sub> during the manufacture and processing of nano-TiO<sub>2</sub> and nano-TiO<sub>2</sub>-enhanced products. These workers are likely exposed on a regular basis through routine occupational activities. These workers may use personal protective equipment (PPE) and engineering controls to mitigate exposures. Although guidance for safe handling of nanomaterials in general is available; specific information on PPE and engineering controls currently in place during the manufacture and processing of nano-TiO<sub>2</sub> has not been identified. The International Council on Nanotechnology (ICON) and the University of California at Santa Barbara (UCSB) developed a plan to conduct a survey of workplaces that use nanomaterials. The first phase of this survey, documented in a report released in October 2006, describes existing and planned efforts to discover and summarize current industrial practices in workplace safety and environmental and product stewardship for nanomaterials. A second phase of this work will include directly surveying nanotechnological organizations regarding their current workplace practices and environmental and product stewardship. This second phase of work is expected to be completed in summer of 2010<sup>43</sup>.

Occupational workers are also exposed to nano-TiO<sub>2</sub> in laboratory, HAZMAT emergency response, and military applications. These workers may use nano-TiO<sub>2</sub> in remediation and decontamination applications. These activities are not expected to occur on a routine daily basis. Furthermore, these workers most likely wear PPE for protection from the source of contamination. The effectiveness of such PPE on mitigating nano-TiO<sub>2</sub> exposures is currently unknown.

Consumers are exposed to nano-TiO<sub>2</sub> through the use of the nanomaterial-enhanced products in their homes or outdoors. For example, the use of self-cleaning coatings and sunscreens present exposure pathways to consumers. The duration and frequency of these exposures depend on the activity patterns of an individual consumer with a specific product. For example, the exposures to a self-cleaning coating may vary with the frequency with which a consumer applies the coating to household surfaces. The exposures to the coating may vary with the exact surface the consumer treated. Coating high-traffic areas or common use items would result in a greater frequency of exposure than lesser used areas or items.

As an additional example, exposures from the use of sunscreens depend on a user's specific activity pattern. Some individuals may engage in outdoor activities that require sunscreen more often than other individuals. Similarly, consumers in sun-intense locations (such as tropical areas or ski resorts) are more likely to apply sunscreen than those in northern climates. No information

---

or current studies to evaluate these activity patterns or differences in sub-population exposures (related to geographic areas) were identified.

Finally, the general population is potentially exposed to nano-TiO<sub>2</sub> through various environmental pathways. This review has identified potential exposure pathways that may introduce nano-TiO<sub>2</sub> into various environmental media. General population exposures may result from nano-TiO<sub>2</sub> in surface waters, groundwater, soil, and air. Nano-TiO<sub>2</sub> in surface waters and groundwater may transport into drinking water supplies. The subsequent transport of nano-TiO<sub>2</sub> from the drinking water supply into the delivered drinking water depends on the fate and transport of nano-TiO<sub>2</sub> within the drinking water plant.

---

## 7. TOXIC EFFECTS

The following section provides a cursory review of the toxicological and ecological effects literature related to nanoscale TiO<sub>2</sub>. Though this section has been included for completeness, it is not intended to be an in-depth review of existing data collected by the scientific community. A critical evaluation of the citations that were reviewed is outside the scope of this report. No attempt has been made to draw conclusions based on the cited studies, nor to provide a body of evidence suggesting potential concerns, or lack thereof; rather, the intent is to identify and briefly summarize applicable studies for further review. It should be noted that a more complete evaluation of toxic effects is anticipated as part of a complimentary project that includes a case study of nano-TiO<sub>2</sub> specifically as used in sunscreens. This project is being conducted by EPA's National Center for Environmental Assessment (NCEA).<sup>1</sup> The final draft is undergoing formal peer review, is expected to be released in the summer of 2010, and may supplement or supersede information provided below in subsections 7.1 through 7.3.

The literature reviewed for this report is summarized in the following subsections:

- Section 7.1 summarizes literature pertaining to the toxic effects of exposures to nano-TiO<sub>2</sub> as reported in animal and human studies. This section is organized by the route of exposure (i.e., inhalation, dermal, and oral)
- Section 7.2 summarizes literature pertaining to the ecological effects of exposures to nano-TiO<sub>2</sub>. This section is organized by environmental compartment (i.e., aquatic and terrestrial receptors).
- Section 7.3 provides additional literature that was identified but not discussed in detail in Sections 7.1 and 7.2 due to their anticipated inclusion in the NCEA case study. These studies are listed in Table 7-3 and should be thoroughly reviewed to provide a more informed perspective.

### 7.1 Health Effects

Overall, the reported health effects from exposures to nano-TiO<sub>2</sub> varied depending on exposure concentrations and conditions. Inhalation exposure studies observed that the toxicity of nano-TiO<sub>2</sub> was dependent not only on concentration but also on the physical properties of the materials (e.g., specific surface area, mineral phase). Literature reporting human dermal absorption of nano-TiO<sub>2</sub> found that the nanoparticles did not penetrate through the stratum corneum under the conditions studied. Selected results reported in the literature for each route of entry are summarized in Table 7-1.

**Table 7-1. Summary of Toxicity Effects**

Exposure Route	Test Species or Cell Tissue Type	Dose	Particle Diameter (nm)	Specific Surface Area (m <sup>2</sup> /g)	Crystalline Phase	Experiment Type	Reported Observation	Reference
Inhalation	human lung epithelial cells	3.6 - 2,000 ug/mL 1-48 hours	3-21	50-150	anatase, rutile	<i>in vivo</i>	cell death for conc. range of 0.1 to 2 mg/mL	44
	Human	0.1 - 1.31 mg/m <sup>3</sup> Duration not provided	10-300	36-124	anatase	model prediction	EC50 of 0.43 ug/mL for inflammatory response	45
Dermal	human skin	0.1 g/cm <sup>2</sup> 2 hours	21	50	anatase, rutile (80%, 20%)	<i>ex vivo</i>	No penetration through skin for test dose of 0.1 g/cm <sup>2</sup> Penetration depth of about 2 um	46
	human skin	50 mg/cm <sup>2</sup> 2 hours		300		<i>ex vivo</i>	No penetration through skin for test dose of 50 mg/cm <sup>2</sup>	47
Oral	Rat	0.175 - 5 g/kg 48 hours	96-184	38.5	rutile	<i>in vivo</i>	NOEL for mouse death test dose range of 175 to 5,000 mg/kg	48
	Rat	2 g/kg Lethal dose		≥ 500	amorphous	<i>in vivo</i>	NOEL for mouse death test dose of 2,000 mg/kg	49

Note: blank fields denote that information was not provided in the reviewed literature sources.

---

### 7.1.1 Inhalation Studies or Effects

#### **In Vivo Studies on Human Lung Epithelial Cells**

Studies of human lung cells exposed to nano-TiO<sub>2</sub> reported cell death over a wide range of concentrations (3.6 to 2,000 ug/mL) over 1 to 48-hour exposures<sup>44,50</sup>. It was also observed that the toxicity depended on the crystal structure of nano-TiO<sub>2</sub>. Sayes et al.<sup>50</sup> reported an anatase LC<sub>50</sub> of 3.6 ug/ml while simultaneously reporting a rutile LC<sub>50</sub> of 550 ug/ml. These results were based on 48-hour exposures to test single doses ranging from 0.001 to 1,000 ug/mL.

#### **Modeling Studies based on Human Inhalation Data**

A surface area-based risk assessment model developed by Liao et al.<sup>51</sup> suggested the median surface area of nano-TiO<sub>2</sub>, upon which elevated lung inflammation would be observed, is 0.11 m<sup>2</sup>/g. The results also suggested that surface area matters more than particle mass when quantifying inflammatory responses to nano-TiO<sub>2</sub>. Additional work by Liao et al.<sup>45</sup>, studying the effects of size and phase composition on nano-TiO<sub>2</sub> exposure to human lung epithelial cells, estimated the half maximum effective concentration (EC<sub>50</sub>) of 432.4 ng/mL for anatase nano-TiO<sub>2</sub>-induced inflammation.

#### **Current Regulations and Standards for nano-TiO<sub>2</sub> in the Air**

For occupational exposures, the National Institute for Occupational Safety and Health (NIOSH) has suggested an occupational exposure limit of 0.1 mg/m<sup>3</sup> as a 10-hr time-weighted average (TWA) during a 40-hr work week<sup>35,51</sup>. This exposure limit was established using the international definitions of respirable dust and the NIOSH Method 0600 for sampling airborne respirable particles<sup>52</sup>. The reader should note that this estimation is based on surface area; therefore, it has been suggested that higher surface area nano-TiO<sub>2</sub> samples may require lower exposure limits. Also, the particle phase and surface activity were not considered in the NIOSH estimation. It should be noted that the NIOSH-recommended exposure limit was obtained from a draft document and is; therefore, subject to change in the final draft. Information submitted by E.I. du Pont de Nemours and Company to the EPA Nanoscale Materials Stewardship Program (NMSP) suggested an alternate occupational exposure limit of 2 mg/m<sup>3</sup> for an 8-hour TWA<sup>3</sup>.

Neither the Occupational Safety and Health Administration (OSHA) nor the American Conference of Governmental Industrial Hygienists (ACGIH) have established nano-TiO<sub>2</sub> limits. Although OSHA has not established a Permissible Exposure Limit (PEL) for nano-TiO<sub>2</sub>, particulate forms would be regulated by the OSHA PELs for total dust (15 mg/m<sup>3</sup> 8-hr TWA) and respirable dust (5 mg/m<sup>3</sup> 8-hr TWA). These are generic PELs that pertain to inert or nuisance dusts and are not specific to nano-TiO<sub>2</sub> or nanoscale materials.

The current ACGIH Threshold Limit Value (TLV) for TiO<sub>2</sub> is 10 mg/m<sup>3</sup> as an 8-hr TWA for total dust. This TLV is not specific to the nanoscale form of TiO<sub>2</sub>. The TLV is intended to minimize respiratory tract irritation and potential overload of pulmonary air-space architecture and normal clearance mechanisms. Also, ACGIH has deemed TiO<sub>2</sub> “Not Classifiable as a Human Carcinogen.” It should be noted that ACGIH is currently soliciting information and data pertaining to TiO<sub>2</sub>, though it is not clear if this includes nanoscale TiO<sub>2</sub>.

### 7.1.2 Dermal Studies or Effects

NMSP submissions from DuPont<sup>3</sup> and Evonik<sup>5</sup> suggest that nano-TiO<sub>2</sub> is not expected to be a skin irritant or sensitizer and that nano-TiO<sub>2</sub> is a “mild irritant” 3 days after application to human skin<sup>5</sup>. The exposure concentration for this observation was not specified. More detailed investigations by Gontier et al.<sup>46</sup> and van der Merve et al.<sup>47</sup> suggested that nano-TiO<sub>2</sub> did not penetrate the stratum corneum after a 2-hour exposure period. The nano-TiO<sub>2</sub> was applied as a sunscreen by Gontier et al. at a dose of 0.1 g/cm<sup>2</sup> while van der Merwe et al. applied it as a powdered material dose rate of 50 mg/cm<sup>2</sup>. Utilizing electron microscopy, both studies showed evidence that suggested nano-TiO<sub>2</sub> did not penetrate beyond the stratum corneum. Gontier et al. estimated the penetration thickness to be approximately 2 μm.

### 7.1.3 Oral Administration Studies or Effects

Studies evaluating oral effects in rats were identified during the literature review. Nano-TiO<sub>2</sub> doses, ranging in concentration from 175 to 5,000 mg/kg for 48 hours, was administered by Warheit et al.<sup>3,48</sup> as single oral doses. No corresponding mortality or weight loss was observed. Similar single dose studies<sup>49</sup> reported no observed mortality at an LD<sub>50</sub> of greater than 2 g/kg.

## 7.2 Ecological Effects

Ecotoxicity effects from exposures to nano-TiO<sub>2</sub> were identified in the literature for various aquatic and terrestrial life including rainbow trout, *Daphnia magna*, wood lice, and green algae. Selected results reported in the literature are summarized in Table 7-2. Further discussion is provided in the following subsections.

**Table 7-2. Summary of Ecotoxicity Effects**

Environmental Compartment	Test Species	Reported Observation	Exposure Duration	Reference
Aquatic	Rainbow trout, <i>Oncorhynchus mykiss</i>	LC <sub>50</sub> of 100 mg/L	8 weeks	53
		Low hazard, EC <sub>50</sub> > 100 ug/mL	96 hours	3
	Invertebrates, <i>Daphnia magna</i>	LC <sub>50</sub> of 5.5 ppm	1 hour	54
		Low hazard, EC <sub>50</sub> > 100 ug/mL	48 hours	3
	Green algae, <i>Pseudokirchneriella subcapitata</i>	NOEC for test dose of 10 mg/L	72 hours	3
Terrestrial	Wood louse, <i>Porcellio scaber</i>	NOEL for test dose of 3 mg/gm	3 days	55

### 7.2.1 Aquatic Life

Studies conducted by E.I. du Pont de Nemours and Company<sup>3</sup> suggested that nano-TiO<sub>2</sub> has low acute toxicity to rainbow trout (*Oncorhynchus mykiss*). A median lethal concentration (LC<sub>50</sub>) of 100 mg/L was reported in their NMSP submission.

More detailed studies of the effects of sub-lethal dietary exposure to nano-TiO<sub>2</sub> in rainbow trout were investigated by Ramsden et al.<sup>53</sup> and Handy<sup>56</sup>. Their studies showed no observable effect on growth. In addition, no major disturbances were observed in red or white blood cell counts, hematocrits, whole blood hemoglobin, or plasma Na<sup>+</sup>; however, subtle biochemical disturbances

---

were observed in the brain<sup>53</sup>. Both studies found evidence of TiO<sub>2</sub> accumulation in the gill, gut, liver, brain and spleen during dietary exposure. Ramsden et al. also suggested that the risk of accidental ingestion of TiO<sub>2</sub> nanoparticles from contaminated trout may be limited as the TiO<sub>2</sub> was not found to accumulate in edible muscle at the concentrations and time scales studied.

Studies<sup>3,54</sup> conducted on *Daphnia magna* reported observable toxicological effects from nano-TiO<sub>2</sub>. The DuPont NMSP<sup>3</sup> suggested a low acute toxicity with maximal effective concentration (EC<sub>50</sub>) of 100 ppm for a 48-hour exposure period. An exposure study by Lovern et al.<sup>54</sup> measured the toxic effects of nano-TiO<sub>2</sub> suspensions and found that the median lethal dose (LD<sub>50</sub>) was about 5.5 ppm for a 1-hour exposure period. Lovern et al. also found that exposure to nano-TiO<sub>2</sub> suspensions did not induce statistically-significant behavioral changes.

An assessment of the toxicity of nano-TiO<sub>2</sub> on various microbial species conducted by Wu et al.<sup>57</sup> found no observable affect on cell growth rates for each of the subject species studied. These included *Escherichia coli*, *Mycobacterium smegmatis*, *Shewanella oneidensis MR-1*, *Cyanothecce* sp. ATCC 51142, and *Saccharomyces cerevisiae*.

The DuPont NMSP suggested that nano-TiO<sub>2</sub> has medium acute toxicity to green algae. Their submission stated a no observed effect concentration (NOEC) of 10 mg/L for a 72-hour exposure period.

### **7.2.2 Terrestrial Life**

The effects of ingested nano-TiO<sub>2</sub> on wood lice (*Porcellio scaber*) were investigated by Jemec et al.<sup>55</sup> The results of this short term (3 day) exposure study suggested that antioxidant enzyme activity in digestive glands were affected in a dose-independent manner; however, there were no observable changes in weight, feeding rate, food assimilation efficiency, or survival up to the highest tested food concentration of 3 mg/g.

## **7.3 Additional Literature**

As stated in this section's introductory text, the previous summaries were intended to provide a cursory review of the toxicological and ecological effects literature related to nanoscale TiO<sub>2</sub>. As such, it was not possible to discuss all of the identified literature while keeping discussion limited to a brief overview. For completeness, the studies that were identified but not discussed are provided in Table 7-3. The reader is also encouraged to review the NCEA nanomaterial case study for TiO<sub>2</sub>, which provides a thorough review of the existing body of literature and discusses the toxicological and ecological effects of nano-TiO<sub>2</sub> in greater detail.<sup>1</sup>

**Table 7-3. Additional Titles Discussing nano-TiO<sub>2</sub> Ecological and Toxicological Effects**

No.	Title	Primary Author	Publication Title	Publication Year
1	Induction of chronic inflammation in mice treated with titanium dioxide nanoparticles by intratracheal instillation	E. J. Park	Toxicology	2009
2	Assessing the airborne titanium dioxide nanoparticle-related exposure hazard at workplace	C. M. Liao	J Hazard Mater.	2009
3	Role of the air-water interface in the retention of TiO <sub>2</sub> nanoparticles in porous media during primary drainage	L. Chen	Env Sci Tech.	2008
4	Exposure to Titanium Dioxide Nanomaterials Provokes Inflammation of an in Vitro Human Immune Construct	B. C. Shanen	ACS Nano	2009
5	Titanium dioxide nanoparticles induce apoptosis through the JNK/p38-caspase-8-Bid pathway in phytohemagglutinin-stimulated human lymphocytes	S. J. Kang	Biochem Biophys Res Commun.	2009
6	The safety of nanosized particles in titanium dioxide- and zinc oxide-based sunscreens	M. Newman	J Amer Acad Derm.	2009
7	Interaction between titanium dioxide nanoparticles and human serum albumin revealed by fluorescence spectroscopy in the absence of photoactivation	W. Sun	J Luminescence	2009
8	Hazard reduction for the application of titanium dioxide nanoparticles in environmental technology	L. Reijnders	J Hazard Mater.	2008
9	Toxicity and interaction of titanium dioxide nanoparticles with microtubule protein	Z. N. Gheshlaghi	Acta Biochim Biophys Sin	2008
10	Titanium dioxide produces reactive oxygen species in immortalised brain microglia: implications for nanoparticle neurotoxicity	T. C. Long	Env Sci Tech.	2006
11	Oxidative stress and proinflammatory effects of carbon black and titanium dioxide nanoparticles: role of particle surface area and internalised amount	S. Hussain	Toxicology	2009
12	Nano-sized titanium dioxide: Effects of gestational exposure	K. S. Hougaard	37th Annual Conference of the European Teratology Society	2009
13	Maternal exposure to nanoparticulate titanium dioxide during the prenatal period alters gene expression related to brain development in the mouse	M. Shimizu	Part Fibre Toxicol.	2009
14	Exposure to titanium dioxide and other metallic oxide nanoparticles induces cytotoxicity on human neural cells and fibroblasts	J. C. K. Lai	Int J Nanomedicine	2008
15	Nano titanium dioxide photocatalytic protein tyrosine nitration: A potential hazard of TiO <sub>2</sub> on skin.	N. Lu	Biochem Biophys Res Commun.	2008

**Table 7-3. Additional Titles Discussing nano-TiO<sub>2</sub> Ecological and Toxicological Effects**

No.	Title	Primary Author	Publication Title	Publication Year
16	Aggregation and toxicology of titanium dioxide nanoparticles	P. Baveye	Env Health Persp.	2008
17	Inhalation Exposure Study of Titanium Dioxide Nanoparticles with a Primary Particle Size of 2 to 5 nm	V. Grassian	Env Health Persp.	2007
18	Time-dependent translocation and potential impairment on central nervous system by intranasally instilled titanium dioxide nanoparticles	J. Wang	Toxicology	2005
19	Dietary exposure to titanium dioxide nanoparticles in rainbow trout, ( <i>Oncorhynchus mykiss</i> ): no effect on growth, but subtle biochemical disturbances in the brain	C. S. Ramsden	Ecotoxicology	2009
20	Genotoxic responses to titanium dioxide nanoparticles and fullerene in gpt delta transgenic MEF cells	A. Xu	Part Fibre Toxicol.	2009
21	Lung injury study by 15 days inhalation exposure of titanium dioxide nanoparticles in rats	K. Lee	Abstracts of the 46th Congress of the European Societies of Toxicology	2009
22	Model-based assessment for human inhalation exposure risk to airborne nano/fine titanium dioxide particles	C. M. Liao	Sci Total Environ.	2008
23	Behavioural and physiological changes in <i>Daphnia magna</i> when exposed to nanoparticle suspensions (titanium dioxide, nano-carbon 60, and specified fullerene derivative)	S. B. Lovern	Env Sci Tech.	2007
24	Effects of ingested nano-sized titanium dioxide on terrestrial isopods ( <i>Porcellio scaber</i> )	A. Jemec	Env Tox Chem.	2008
25	Nanosize titanium dioxide stimulates reactive oxygen species in brain microglia and damages neurons, in vitro.	T. C. Long	Env Health Persp.	2007
26	Comparative study on the acute and pulmonary toxicity induced by 3 and 20 nanometres titanium dioxide primary particles in mice	J. Li	Env Tox Pharm.	2007
27	Correlating Nanoscale Titania Structure with Toxicity: A Cytotoxicity and Inflammatory Response Study with Human Dermal Fibroblasts and Human Lung Epithelial Cells	C. M. Sayes	Tox Sci.	2006
28	Ultrafine titanium dioxide nanoparticles induce cell death in human bronchial epithelial cells	E. Chen	J Exp. Nanoscience	2008
29	Titanium dioxide nanoparticles induce oxidative stress and DNA-adduct formation but not DNA-breakage in human lung cells.	K. Bhattacharya	Part Fibre Toxicol.	2009

**Table 7-3. Additional Titles Discussing nano-TiO<sub>2</sub> Ecological and Toxicological Effects**

No.	Title	Primary Author	Publication Title	Publication Year
30	Is there penetration of titania nanoparticles in sunscreens through skin? A comparative electron and ion microscopy study	E. Gontier	Nanotoxicology	2008
31	In vitro inflammatory response of nanostructured titania, silicon oxide, and polycaprolactone	K. M. Ainslie	J Biomed Mater Res A	2009
32	Comparing fate and effects of three particles of different surface properties: nano-titanium dioxide, pigmentary titanium dioxide and quartz	B. van Ravenzwaay	Tox Letters	2008
33	Energy dispersive X-ray analysis of titanium dioxide nanoparticle distribution after intravenous and subcutaneous injection in mice	A. Patri	J App Tox.	2009
34	Pulmonary toxicity induced by three forms of titanium dioxide nanoparticles via intra-tracheal instillation in rats	R. Liu	Prog Nat Sci.	2009
35	Titanium Dioxide (TiO <sub>2</sub> ) Nanoparticles Induce JB6 Cell Apoptosis Through Activation of the Caspase-8/Bid and Mitochondrial Pathways	J. Zhao	J Toxicol Env Health, Part A	2009
36	Nano titanium dioxide exposure standards			2006
37	Bio-effects of Nano-titanium Dioxide on Lungs of Mice	Y. Y. Zhang	Mat. Res.	2009
38	Deleterious effects of sunscreen titanium dioxide nanoparticles on DNA. Efforts to limit DNA damage by particle surface modification	N. Serpone	SPIE Conf. Proceedings	2003
39	Titanium Dioxide Nanoparticles Induce DNA Damage and Genetic Instability In vivo in Mice	B. Trouiller	Cancer Res.	2009
40	Nanocrystalline titanium dioxide and magnesium oxide in vitro dermal absorption in human skin	D. van der Mer	Cutaneous and Ocular Toxicology	2009
41	Aquatic toxicity evaluation of titanium dioxide nanoparticle produced from sludge of titanium tetrachloride flocculation of waste water and sea water	B. C. Lee	J Nanoparticle Res.	2008
42	Adverse Effects of Titanium Dioxide Nanoparticles on Human Dermal Fibroblasts and How to Protect Cells	Z. Pan	Small	2009
43	Nanometer titanium dioxide and its toxicology progress	Y. Wang	Chinese J Pharm Tox.	2008

**Table 7-3. Additional Titles Discussing nano-TiO<sub>2</sub> Ecological and Toxicological Effects**

No.	Title	Primary Author	Publication Title	Publication Year
44	Fate, Transport and Toxicity of Nanomaterials in Drinking Water	Y. Zhang	Tech. Proc., 2007 NSTI Nanotechnology Conference and Trade Show Vol. 2	2007
45	Test Method for Skin Damage of Titania Photocatalyst Nanoparticles in vitro	E. Watanabe	Mat Sci Forum	2008
46	Methods for the Prediction of Nanoparticle Fate, Transport and Receptor Exposure in an Aqueous Environment	C.E. Mackay	Nanotech 2007	2007
47	Titanium dioxide nanoparticles trigger p53-mediated damage response in peripheral blood lymphocytes	S. J. Kang	Environ Mol Mutagen.	2008
48	Titanium dioxide nanoparticle absorbed by hepatoma cells in vitro	H. Sheng	J of Wuhan Univ Tech--Mat Sci Ed.	2005
49	Aggregation and toxicity of titanium dioxide nanoparticles in aquatic environment-A Review	V. K. Sharma	J Env Sci Health, Part A	2009

---

## 8. SAMPLING AND ANALYSIS

The following section provides a cursory review of nano-TiO<sub>2</sub> sampling and analysis techniques that may be applied to environmental media. Though this section has been included for completeness, it is not intended to provide an in-depth literature review of sampling and analysis techniques. Rather, it is intended to provide a cursory review of the body of literature existing for environmental sampling and analysis of nanoparticles. Where possible, literature specific to nano-TiO<sub>2</sub> is identified and discussed. For a more extensive review of analytical techniques suited for general nanomaterials in environmental media, the reader may refer to EPA's *Sampling and Analysis of Nanomaterials in the Environment: A State-of-the-Science Review*.<sup>58</sup>

The reviewed literature was identified using various sources including the Dialog® search results, targeted journals and conference proceedings, as well as other targeted sources. Specific details about Dialog® search parameters and targeted sources are discussed in Section 3.0, Literature Search Strategy.

The reviewed literature is summarized in the following subsections:

- Section 8.1 summarizes literature pertaining to the sampling techniques applied to nanoparticles. Each subsection discusses sampling techniques for different environmental media (surface water, sediments, soil, groundwater, and air).
- Section 8.2 summarizes literature pertaining to the analytical techniques applied to nanoparticles once the samples have been collected from the environment.

### 8.1 Sampling Techniques

Compared to the two other literature search areas ((1) production and applications, and (2) human health and toxicity), there were far fewer studies and literature articles identified in this area that were specific to sampling of environmental media. Information and reports that were reviewed suggest that environmental sampling is a growing area of research with many challenges ahead. Several researchers noted that the challenges posed by environmental sampling must be addressed before reproducible and reliable analysis results can be achieved. Given that nanoparticle-containing samples can change structure during analysis and are susceptible to interferences from within a sample's matrix (e.g., sludge), it is necessary to develop a standardized sampling method that ensures the minimization of such variability. This literature review identified several journal articles that deal specifically with this matter. The findings of this body of literature are summarized in the following paragraphs.

Burleson et al.<sup>59</sup> noted that sample preparation is a critical step in the characterization of nanoparticles since they can change structure and composition in response to changes in their environment. Therefore, when studying nanoparticles, it is important to examine the nanoparticles before, during, and after analysis. A careful record of sample collection, storage procedures, and preparation steps is also recommended so that potential artifacts may be tracked. Potential artifacts that could be encountered during sample preparation include aggregate fragmentation, precipitation of salts, and nanoparticle aggregation.

---

Englert<sup>60</sup> also observed the challenges associated with sampling nanomaterials in the environment. In his review, Englert noted that environmental samples will require wet techniques to remove inherent interferences within sample matrices. Such techniques could make the identification of nanomaterials complicated<sup>60</sup>. Englert also noted that existing techniques for environmental monitoring will need to be expanded upon since, in the author's conclusion, it is likely that many of the current technologies will not function for nanoparticles existing in difficult environmental matrices (e.g., sludge) because of interferences inherent to the sample matrix.

In their review of the challenges associated with sampling and analyzing nanoparticles in the environment, Tiede et al.<sup>61</sup> concluded that standards and reference materials must be developed before comparable and reproducible data can be achieved. For the time being, they recommend full documentation of sample preparation and analysis methods so that future researchers will be able to duplicate methods (or be equipped with information to revise them as appropriate).

Nowack<sup>62</sup> also observed that no quantitative measurements of engineered nanoparticles in the environment have become available and attributed the lack of studies to the absence of analytical methods that can quantify trace concentrations of nanoparticles from environmental samples.

The following subsections summarize identified information regarding sampling techniques for the following five environmental compartments: 1) surface waters, 2) sediments, 3) soil, 4) groundwater, and 5) air.

### ***8.1.1 Sampling Techniques Suited for Surface Waters***

Tiede et al.<sup>61</sup> noted some of the challenges associated with environmental sampling, specifically commenting on water sampling. In their review of the literature, it was observed that experimental conditions and the test medium significantly influence the nanoparticle's form. Furthermore, they noted that aggregation, stabilization, and dissolution of nanomaterials is greatly dependant upon the aquatic system (e.g., sea water, fresh water, buffered systems) because nanoparticle dissolution properties are affected by temperature, pH, ionic strength, and organic complexation<sup>61</sup>.

### ***8.1.2 Sampling Techniques Suited for Sediments***

Three projects were identified that involved sampling sediments for nanomaterials. These projects did not use sampling techniques or protocols that were developed specifically for nano-TiO<sub>2</sub>. The following discussion summarizes the sample collection and preparation techniques described for the three sediment sampling projects.

Hochella et al.<sup>63</sup> demonstrated sampling riverbanks and riverbeds for further analysis of naturally occurring nanomaterials. The authors obtained samples by digging into the side of a riverbank and collected riverbed mud from beneath a layer of sediment under the shallow stream edge. To prepare samples for TEM analysis, the authors performed the following steps. They first air dried their sediment samples before storage. They then lightly grinded the dry samples to make them more friable, which reduced the larger grain sizes and dispersed the sample. The authors then used multiple stages of dry sieves at a cut-off size of 65  $\mu\text{m}$  and then wet sieved in ethanol at 25

---

$\mu\text{m}$ . They performed a final light grinding before preparing the TEM ultramicrotomed thin sections.

Hochella et al.<sup>64</sup> sampled bed sediment from the entrance of a mine for further analysis of natural nanoscale particles. The authors obtained the bed sediment from a small water channel and a small, shallow pond near the entrances of two mines. The authors sieved the wet sediment samples with 63- $\mu\text{m}$  sieves using ambient water to prevent chemical changes from occurring. It was noted that sieving in this case helped to remove detrital material and allowed for a uniform comparison between studies. The authors bottled and ice packed the samples for transport to the laboratory, where they centrifuged and dried the sediment samples. Finally they gently mashed the sediment samples to separate clots and noted the importance of avoiding high-temperature drying to prevent mineralogical changes.

### ***8.1.3 Sampling Techniques Suited for Soil***

Limited information was obtained for soil sampling techniques that are specific to nano-TiO<sub>2</sub> (and for nanomaterials, in general). This data gap may be due to the absence of analytical methods to quantify trace amounts of nanoparticles from environmental samples. Information and reports that were reviewed suggested that nanoparticles in the soil are generally difficult to separate and characterize<sup>65,66,67</sup>. Klaine et al.<sup>68</sup> also noted the added difficulty in separating and distinguishing engineered nanoparticles from other nanosized particles that may naturally exist in the soil sample.

### ***8.1.4 Sampling Techniques Suited for Groundwater***

As with sampling techniques for soil, limited information was obtained for groundwater sampling techniques that are specific to nano-TiO<sub>2</sub> (and for nanomaterials in general). This data gap may also be due to the absence of analytical methods to quantify trace amounts of nanoparticles from environmental samples. Information and reports that were reviewed also suggest that separation techniques and analytical methods that yield reproducible data are yet to be fully developed, understood, and agreed upon by the scientific community.

### ***8.1.5 Sampling Techniques Suited for Air***

Similarly, limited information was obtained for air sampling techniques that are specific to nano-TiO<sub>2</sub> (and for nanomaterials in general). This data gap may also be due to the absence of analytical methods to quantify trace amounts of nanoparticles from environmental samples.

## **8.2 Analytical Techniques**

The following section provides an overall summary of the analytical techniques that can be applied towards the analysis of nano-TiO<sub>2</sub> in environmental media. Additional metrology methods can be used for isolated samples of nano-TiO<sub>2</sub>; however, such methods are not discussed in this report. For a discussion of general metrology and the characterization of nano-TiO<sub>2</sub>, the reader may refer to the NCEA case study for nano-TiO<sub>2</sub>.<sup>1</sup>

The material presented in this section is not limited to techniques specific to nano-TiO<sub>2</sub> only. Instead, background information for various analytical techniques of general nanomaterials in

---

environmental media is provided. Limitations associated with these techniques are also discussed. As previously stated, EPA's *Sampling and Analysis of Nanomaterials in the Environment: A State-of-the-Science Review*<sup>58</sup> provides a more extensive review of analytical techniques suited for general nanomaterials in environmental media.

The reader should be aware that there is not yet any concurrence on a standardized set of specific physicochemical properties that are necessary to fully characterize nanomaterials; although, a concerted effort is underway by the Organisation for Economic Co-operation and Development (OECD). Therefore, the intention of this section is to provide the reader with general background on the typical techniques that are currently employed by researchers. The techniques discussed here are generally applicable and often used.

### **8.2.1 Analytical Techniques for Size Fractionation**

When characterizing natural samples, nanoparticles are not initially separated from larger particles. The sample may need to be separated depending on the analysis methods that will be used. This separation is referred to as size fractionation. Common size fraction techniques include:

- Centrifugation;
- Ultrafiltration;
- Field-flow fractionation (FFF); and
- Capillary electrophoresis (CE).

#### **Centrifugation**

Centrifugation is a mechanical method that separates particles in a solution based on weight by applying a centrifugal force. Heavier particles sink outwardly while lighter particles rise towards the center of the vortex.

#### **Ultrafiltration**

Ultrafiltration separates particles in solution based on molecular weight. The separation can be achieved by either direct-flow (perpendicular to the membrane) ultrafiltration or tangential-flow (cross-flow) ultrafiltration (TFF). The benefit of TFF is that the solution flows parallel to the membrane, which prevents buildup of particles at the membrane surface.

#### **Field-Flow Fractionation (FFF)**

FFF separates particles by applying a perpendicular gradient to a sample solution that is flowing through a narrow channel. The basic principles of FFF are described by Willis<sup>69</sup>. In brief, a sample is injected into the FFF channel as a diffuse mixture. A perpendicular field is then applied, which causes the sample particles to diffuse towards the bottom of the channel. The degree to which particles diffuse towards the bottom of the channel is a function of the particles' hydrodynamic radii and the balance between the force of the applied field and the natural diffusivity of the particles. In general, smaller particles remain farther from the bottom of the channel than larger particles. After equilibrium is established, the perpendicular field is stopped

---

and the channel is eluted under laminar flow, which favors elution of the smaller particles first because they encounter the least amount of drag flow caused by the channel walls.

Multiple types of FFF are in current use, with each type using a different source for the perpendicular force. FFF types include:

- Sedimentation FFF;
- Electrical FFF;
- Thermal FFF; and
- Flow FFF (FI-FFF).

FI-FFF is commonly used for the size fractionation of aqueous suspensions of nanoparticles. FI-FFF uses a cross-flow of a buffer solution to provide the perpendicular field. Researchers commonly use FI-FFF with on-line detectors to measure particle concentrations. These techniques are typically spectral methods such as UV absorbance detectors, fluorescence detectors (FLD), and multi-angle laser light scattering (MALLS). FI-FFF also allows the ease of coupling an on-line detector for chemical analysis, such as inductively-coupled plasma mass spectrometry (ICP-MS).

### **Capillary Electrophoresis (CE)**

Quang et al.<sup>70</sup> demonstrated the feasibility of using capillary electrophoresis to characterize and separate nano-TiO<sub>2</sub> by using inert electrolyte solutions, which provided generally better separations of the metal oxide nanoparticles when compared to separations using unbuffered solutions.

#### ***8.2.2 Analytical Techniques for Size Distribution***

Several analytical techniques are suitable for measuring size distribution of nanoparticles. The microscopy methods discussed in this section either use point count techniques that measure the sizes of individual particles or bulk analyses that measure the average and range of particle sizes in a sample, and include the following:

- Transmission, Scanning, or Environmental Scanning Electron Microscopy (TEM, SEM, or ESEM);
- Scanning Probe Microscopy (SPM);
- Dynamic Light Scattering (DLS);
- Laser-Induced Breakdown Detection (LIBD);
- Small- and Wide-Angle X-Ray Scattering (SAXS/WAXS); and
- Flow Cytometry.

### **TEM, SEM, or ESEM**

TEM provides a direct method of visualizing particle distributions also provides a high resolution (0.1 nm) two-dimensional image of the nanomaterial. TEM techniques are often coupled with other electron diffraction-based spectroscopic tools such as EDS, electron energy loss spectroscopy (EELS), and electron backscatter diffraction (EBSD).<sup>59,61</sup>

---

SEM can be used to measure the individual particle sizes by producing a topographical three-dimension image of the nanomaterial at resolutions ranging from 1 nm to 1  $\mu\text{m}$ . The SEM images may also be used to measure nanoparticle size distributions.

Two of the main drawbacks to TEM and SEM are sample preparation and analysis conditions. In order for samples to conduct the electron beam, the samples must be coated in gold or graphite. Then the sample must be kept under ultrahigh vacuum to prevent possible beam interactions with gas molecules. Both of these drawbacks lead to the possibility of changes in the aggregation state of the sample during preparation or analysis<sup>71</sup>.

A partial solution to the drawbacks stated above is ESEM. In this method, the sample chamber is separated from the detection chamber. This allows the samples to be kept in a gaseous environment, thereby removing the possibility of morphological changes to the nanoparticle aggregates while they are in ultrahigh vacuum. The main disadvantage of ESEM is that the resolution is decreased to about 100 nm because of interactions occurring between the electron beam and water vapor molecules<sup>71, 72</sup>.

### **SPM**

SPM techniques determine the size of individual particles and include atomic force microscopy (AFM) and scanning tunneling microscopy (STM). AFM measures forces between a sharp tip and sample to determine topography. STM measures a tunneling current between a conductive tip and sample to determine topography). Both have resolutions of about 0.1 nm.

### **DLS**

DLS is a bulk analysis technique that measures the average particle size of dispersions or suspensions. Light that is emitted into a sample dispersion or suspension is scattered in all directions. The intensity of the scattering is measured over time and applied to an autocorrelation function, which describes how the measurement relates to itself in a time dependent manner. These data points are then fitted to an exponential decay function which relates the autocorrelation points to the spherical diameters of the nanoparticles using the Stokes-Einstein equation. The advantages of DLS include: rapid and simple operation; readily available equipment; and minimum sample perturbation<sup>71</sup>.

### **LIBD**

LIBD is a bulk analysis that measures the average particle size and concentration of particles in the sample. The method uses an intense, pulsed laser beam to generate plasmas on colloidal particles. The generation of plasmas is called a “breakdown event.” The plasmas generated by the breakdown event emit light or generate shock waves that are detected by the tool. LIBD is based on the difference in breakdown thresholds of liquid and solid matter. The laser beam energy is set to exceed the solid breakdown threshold but not the liquid threshold. The number of breakdown events per number of laser pulses depends on the concentration and size of the particle.

A charged coupled device (CCD) camera detects the light emissions of single plasmas to

---

determine the particle size. Detection of optical spatially resolved plasma light emissions results in a spatial distribution of breakdown events within the focal volume. Spatial distribution depends on the particle size. The authors compare the distribution to the distribution width of reference particles to determine the mean particle diameter. They then calculate the mean particle diameter and breakdown probability

The main advantage to LIBD is its general sensitivity towards nanoparticles. The detection limits range from 5 to 100 nm for particle sizes and parts per trillion (ppt) for concentrations<sup>71</sup>. The disadvantages to LIBD include the inability to discriminate between different types of nanoparticles and the inability to use one set of calibration standards for different types of nanoparticles<sup>71</sup>.

### **SAXS/WAXS**

SAXS/WAXS is a bulk analytical technique that determines particle sizes and populations.

Waychunas et al.<sup>73</sup> demonstrated the use of SAXS/WAXS to determine the size distribution and population of goethite nanoparticles as a function of time. The authors made *in situ* measurements and noted that these particular nanoparticles aggregated in solution as they aged. The authors additionally used SAXS/WAXS to make *ex situ* measurements on samples they measured using other techniques. The authors presented graphical processed SAXS results that demonstrated the aging particle size distributions over time.

Gilbert et al.<sup>74</sup> used SAXS to study the colloidal stability of iron oxyhydroxide nanoparticles as a function of pH and ionic strength over time. The authors made *in situ* measurements and noted slight nanoparticle aggregation after 10 weeks but no macroscopic aggregation even after four months at pH values less than 6.6. The authors noted a greater extent of aggregation at pH values greater than 6.6.

### **Flow Cytometry**

Flow cytometry is a technique for counting and examining microscopic particles, such as cells, by measuring both light scattering and fluorescence of the particles. Flow cytometers measure the small angle forward scatter (FSC) and side scatter (SSC) intensities of the studied particles. It is generally agreed that FSC provides a measure for cellular size comparisons, while SSC provides information on internal structure and organelles of cells.<sup>75</sup>

Research by Zucker et al.<sup>75</sup> has demonstrated the use of flow cytometry to detect and describe the uptake and distribution of nano-TiO<sub>2</sub> into cells. The researchers treated human-derived retinal pigment epithelial cells with suspensions of nano-TiO<sub>2</sub> at various concentrations. The cells were incubated for 24 hours and then observed for changes due to the nano-TiO<sub>2</sub>. The researchers used flow cytometry to measure changes in the light scattering of the cells due to nano-TiO<sub>2</sub> particles and aggregates that transported inside the cells. Dark-field microscopy was additionally used to visually confirm the uptake and intracellular distribution of the nano-TiO<sub>2</sub>. The researchers noted that flow cytometry light scattering was typically proportional to a particle's size; however, it can also be dependent upon the particle's material. Therefore, the flow cytometry results cannot necessarily provide a direct measure of the cellular size. However, the flow cytometry results can be used to measure the relative amount of nanoparticles absorbed

---

by the cell. The researchers hope to correlate changes in the functional cellular processes with flow cytometry light scattering measurements and dark-field microscopy morphological observations in future work.

### **8.2.3 Analytical Techniques for Surface Area**

The average surface area of nanoparticles is a useful characterization parameter. Average surface area may be calculated directly using the Brunauer-Emmett-Teller method (BET). The BET method utilizes a gas, typically nitrogen, to adsorb to the physically-accessible pores of a sample. The adsorbed gas forms a monolayer of molecules or atoms along the accessible surface area. One may then measure the volume of the adsorbed monolayer of gas and, with knowledge of the size of the gas molecules or atoms and the mass of the sample, calculate the surface area per mass of the sample.

It is important to note that the above method for calculating surface area assumes certain regular geometric shapes (e.g., spheres, plates, needles, rods). Therefore, it may not be applicable for every sample, particularly if it is known that the sample is irregularly shaped.

### **8.2.4 Analytical Techniques for Chemical Analysis**

Chemical analytical techniques provide a means to identify the presence of chemical species within a sample. It should be noted that these techniques do not directly identify the presence of a nanoparticle. Instead, these techniques identify the presence of atoms, functional groups, or molecules from which the presence of nanoparticle atoms or molecules can be inferred.

Quantitative methods for nanoparticle chemical analysis include inductively-coupled plasma mass spectroscopy (ICP-MS) and atomic absorption spectrometry (ICP-AES). The sample is dissolved in an inorganic acid (e.g., nitric, hydrofluoric acid) and sent through a nebulizer which atomizes the sample just before it is fed into the plasma. The plasma then breaks down the sample and creates excited atoms and ions. In ICP-MS the ions are extracted through a series of cones before entering into the mass spectrometer detector. In ICP-AES the electromagnetic radiation resulting from the sample-plasma interaction is sent through an optical chamber, which separates the light into its different wavelengths before the light intensity is measured by the photomultiplier. One of the main disadvantages of applying ICP-MS or ICP-AES methods towards environmental media is that the acids used in sample preparation may volatilize, enrich, or deplete the nanoparticles in the sample<sup>59</sup>.

Energy-dispersive x-ray spectroscopy (EDS) can also be used for the chemical analysis of environmental samples. Using HR-TEM-EDS Wigginton et al.<sup>76</sup> demonstrated the application of this technique towards identifying TiO<sub>2</sub> nanoparticles in river water samples that were affected by contamination from a nearby mine. In their analysis, Wigginton et al. were able to identify several metal-bearing nanoparticles, including nano-TiO<sub>2</sub>.

### **8.2.5 Analytical Techniques for Direct Visualization**

Direct visualization can produce a direct image of individual nanoparticles from a small sample. Visualization allows one to examine geometry and shape characteristics of the observed nanoparticles. Techniques for direct visualization include:

- 
- Electron microscopy techniques, such as transmission electron microscopy (TEM) and scanning electron microscopy (SEM); and
  - Scanning probe microscopy (SPM), such as atomic force microscopy (AFM) and scanning tunneling microscopy (STM).

### **Electron Microscopy**

TEM and SEM microscopy provide high-resolution images that are used to characterize particle size, size distribution, and morphology<sup>59</sup>. The biggest advantage of electron microscopy techniques is that they provide a direct image of the nanoparticle being studied. A disadvantage of electron microscopy is that only a small amount of material is characterized. Care must be taken to ensure that the recorded samples are representative of all samples. Burleson et al.<sup>59</sup> notes that SEM is an ideal technique for imaging particles that range in size from 50 nm to several mm. For particles smaller than 50 nm, TEM is better suited for imaging. The TEM can also determine crystallography through electron backscatter diffraction (EBSD). One of the major disadvantages of TEM is that characterization of the nanoparticle is done through an ex situ method, which means that sample preparation and insertion into the TEM can introduce artifacts.

### **Scanning Probe Microscopy**

SPM is another technique that is applied to the direct visualization of nanoparticles. Burleson notes that of the various SPM techniques, atomic force microscopy (AFM) is most commonly applied to environmental nanoparticles<sup>59</sup>. One of the major advantages of AFM is that it is capable of imaging at sub-nanometer resolutions. It should be noted that no chemical information can be obtained from AFM.

#### ***8.2.6 Analytical Techniques for Mineral Phase/Internal Structure***

The structure of nanoparticles may be crystalline or amorphous. Knowledge of the structure and chemistry of crystalline nanoparticles provides insight into the mineral phase of the nanoparticle. Techniques that provide such information include electron diffraction, X-ray diffraction (XRD), X-ray absorption spectroscopy (XAS), and Raman spectroscopy.

### **Electron Diffraction**

Crystallinity can be observed through the diffraction of electrons as they pass through a sample. Using HR-TEM-EDS, Wigginton et al.<sup>76</sup> were able to identify that the nano-TiO<sub>2</sub> in their river water samples possessed crystalline features. The presence of the crystallinity was suggested by well-defined lattice fringes directly observable in their TEM images.

---

### **X-ray Diffraction**

This technique measures the diffraction of X-rays to identify crystalline phases. When compared to a database of known diffraction patterns, it can be used to quantitatively identify mineral composition. Typically, samples are staged on a sample plate in powder form. Care should be taken to ensure that sample results are representative of the material being studied.

### **X-Ray Absorption Spectroscopy**

XAS techniques can provide detailed structural information about environmental nanoparticles. They are often used to characterize materials containing substantial amounts of nanoparticle components.<sup>59</sup> Burleson noted that XAS fills an important niche since individual species are hard to detect and measure in XRD.

---

## 9. REFERENCES

1. Environmental Protection Agency *Nanomaterial Case Studies: Nanoscale Titanium Dioxide (External Review Draft)*; EPA/600/R-09/057; U.S. Environmental Protection Agency: Washington, D.C., 09.
2. Titanium Compounds, Inorganic. In *Kirk-Othmer Encyclopedia of Chemical Technology*, (Online) ed.; Wiley: New York, 2000; pp 1-58.
3. E.I. du Pont de Nemours and Company *DuPont Light Stabilizer Framework Example - Nanomaterial Risk Assessment Worksheet DuPont Light Stabilizer*. 2007.
4. U.S. Geological Survey *Mineral Commodity Summaries 2008*. U.S. Geological Survey: 2008; pp 178-181.
5. Evonik Degussa Corporation *NMSP Submission for Titanium Oxide*. 2008.
6. Woodrow Wilson International Center for Scholars The Project on Emerging Nanotechnologies: Consumer Products Inventory. <http://www.nanotechproject.org/inventories/consumer/> **2010**.
7. NanoScale Corporation <http://www.nanoscalecorp.com/> **2008**.
8. NanoScale Corporation *NanoActive Titanium Dioxide*. 2009.
9. Ou, H.-H.; Lo, S.-L. Review of Titania Nanotubes Synthesized via the Hydrothermal Treatment: Fabrication, Modification, and Application. *Separation and Purification Technology* **2007**, *58*, 179-191.
10. Zhang, L.; Huang, T.; Liu, N.; Liu, X. Sorption of Thallium(III) Ions from Aqueous Solutions Using Titanium Dioxide Nanoparticles. *Microchimica Acta* **2008**, *165*, 73-78.
11. Labbe, M. Photocatalytic Degradation of Select Drinking Water Pollutants Using Nano-TiO<sub>2</sub> Catalyst. University of Windsor, 2008.
12. Tsuru, T.; Narita, M.; Shinagawa, R.; Yoshioka, T. Nanoporous Titania Membranes for Permeation and Filtration of Organic Solutions. *Desalination* **2008**, *233*, 1-9.
13. Zhang, H.; Quan, X.; Chen, S.; Zhao, H.; Zhao, Y. The Removal of Sodium Dodecylbenzene Sulfonate Surfactant from Water Using Silica/Titania Nanorods/Nanotubes Composite Membrane with Photocatalytic Capability. *Applied Surface Science* **2006**, *252*, 8598-8604.
14. Mahmoodi, N. M.; Arami, M. Degradation and Toxicity Reduction of Textile Wastewater Using Immobilized Titania Nanophotocatalysis. *Journal of Photochemistry and Photobiology B: Biology* **2009**, *94*, 20-24.

- 
15. Yang, X.; Cao, C.; Erickson, L.; Hohn, K.; Maghirang, R.; Klabunde, K. Photocatalytic Activity of Multi-Doped TiO<sub>2</sub> Nanoparticles for Degredation of Rhodamine B. 2009.
  16. Yang, X.; Cao, C.; Erickson, L.; Hohn, K.; Maghirang, R.; Klabunde, K. Photo-catalytic degradation of Rhodamine B on C-, S-, N-, and Fe-Doped TiO<sub>2</sub> under Visible-Light Irridation. *Applied Catalysis B: Environmental* **2009**, *91*, 657-662.
  17. Niu, J.; Chen, S.; Wang, L.; He, Y.; Wang, J. Degradation of Polycyclic Aromatic Hydrocarbons in Water/Methanol Solutions with Nanoparticle Photocatalysts Based on Silver Doped TiO<sub>2</sub>. 2007.
  18. Chin Choy, C. R. Injection of nanocrystalline titanium dioxide into porous media for uranium contaminated groundwater remediation. **Stevens Institute of Technology**, 2007.
  19. Fryxell, G. E. Nanomaterials for Environmental Remediation. 6-9-2004.  
Ref Type: Slide
  20. Eckels, S.; Koper, O. B.; Erickson, L. E.; Bayless, L. V. Nanoscale Catalysts and In-Room Devices to Improve Indoor Air Quality and Sustainability. In *Nanoscale Materials in Chemistry: Environmental Applications*, 2010.
  21. Li, Y. Removal of Elemental Mercury from Flue Gas Using Nanostructured Silica/Titania/Vanadia Composites. University of Florida, 2007.
  22. Chen, X.; Mao, S. Titanium Dioxide Nanomaterials: Synthesis, Properties, Modifications, and Applications. *Chemical Reviews* **2007**, *107*, 2891-2959.
  23. Prasad, G. K.; Mahato, T. H.; Singh, B.; Ganesan, K.; Srivastava, A. R.; Kaushik, M. P.; Vijayraghavan, R. Decontamination of Sulfur Mustard and Sarin on Titania Nanotubes. *AIChE Journal* **2008**, *54* (11), 2957-2963.
  24. Johnson, C. R. Titania Nanotubes Could Cut Solar-Cell Costs. *EE Times*, **Feb 6, 2006**.
  25. Silver-Supported Nanometer Titanium Dioxide Antibacterial Material. *China Chemical Reporter*, **Nov 26, 2005**, p 496.
  26. Using Titanium Dioxide to Treat Brain Cancer. *Ceramic Industry*, **Oct 1, 2009**.
  27. Zhang, L. Plasma Synthesis of Metal Oxide Nanoparticles. DE, U.S. US 7,217,407 B2, May 15, 2007.
  28. Robichaud, C. O.; Uyar, A. E.; Darby, M. R.; Zucker, L. G.; Wiesner, M. R. Estimates of Upper Bounds and Trends in Nano-TiO<sub>2</sub> Production As a Basis for Exposure Assessment. *Environmental Science & Technology* **2009**, *43* (12), 4227-4233.
  29. Evonik Degussa Corporation Aerosil Product Finder. <http://www.aerosil.com/lpa-productfinder/page/productsbyindustry/faces/industrysearch.jsp?lang=en> **2010**.

- 
30. Kobo Products, I. Sunscreen Technologies. <http://www.koboproductsinc.com/UVPigments.html> **2010**.
  31. Eriksson, E.; Andersen, H. R.; Ledin, A. Substance Flow Analysis and Source Mapping of Chemical UV-filters. *Water, Air, & Soil Pollution: Focus* **2008**, *8*, 473-484.
  32. Mueller, N. C.; Nowack, B. Exposure Modeling of Engineered Nanoparticles in the Environment. *Environmental Science & Technology* **2008**, *42* (12), 4447-4453.
  33. Environmental Protection Agency Municipal Solid Waste Generation, Recycling, and Disposal in the United States: Facts and Figures for 2008. <http://www.epa.gov/epawaste/nonhaz/municipal/pubs/msw2008rpt.pdf> **2009**.
  34. Environmental Protection Agency Municipal Solid Waste: Combustion. <http://www.epa.gov/epawaste/nonhaz/municipal/combustion.htm> **2008**.
  35. Brar, S. K.; Verma, M.; Tyagi, R. D.; Surampalli, R. Y. Engineered Nanoparticles in Wastewater and Wastewater sludge - Evidence and Impacts. *Waste Management* **2010**, *30*, 504-520.
  36. Schmidt, J.; Vogelsberger, W. Aqueous Long-Term Solubility of Titania Nanoparticles and Titanium(IV) Hydrolysis in a Sodium Chloride System Studied by Adsorptive Stripping Voltammetry. *Journal of Solution Chemistry* **2010**, *38*, 1267-1282.
  37. Guzman, K. A. D.; Finnegan, M. P.; Banfield, J. F. Influence of Surface Potential on Aggregation and Transport of Titania Nanoparticles. *Environmental Science and Technology* **2006**, *40* (24), 7688-7693.
  38. Chen, L.; Sabatini, D. A.; Kibbey, T. C. G. Role of the air-water interface in the retention of TiO<sub>2</sub> nanoparticles in porous media during primary drainage. *Environmental Science & Technology* **2008**, *42* (6), 1916-1921.
  39. Kiser, M. A.; Westerhoff, P.; Benn, T.; Wang, Y.; Peñúrez-Rivera, J.; Hristovski, K. Titanium Nanomaterial Removal and Release from Wastewater Treatment Plants. *Environmental Science & Technology* **2009**, *43* (17), 6757-6763.
  40. Lecoanet, H. F.; Bottero, J.-Y.; Wiesner, M. R. Laboratory Assessment of the Mobility of Nanomaterials in Porous Media. *Environmental Science & Technology* **2004**, *38*, 5164-5169.
  41. Fang, J.; Shan, X.; Wen, B.; Lin, J.; Owens, G. Stability of Titania Nanoparticles in Soil Suspensions and Transport in Saturated Homogeneous Soil Columns. *Environmental Pollution* **2009**, *157*, 1101-1109.
  42. Gottschalk, F.; Scholz, R. W.; Nowack, B. Probabilistic material flow modeling for assessing the environmental exposure to compounds: Methodology and an application to engineered nano-TiO<sub>2</sub> particles. *Environmental Modelling & Software* **2010**, *25*, 320-332.

- 
43. International Council on Nanotechnology *Review of Safety Practices in the Nanotechnology Industry*. 2006.
  44. Sayes, C. M.; Wahi, R.; Kurian, P. A.; Liu, Y.; West, J. L.; Ausman, K. D.; Warheit, D. B.; Colvin, V. L. Correlating Nanoscale Titania Structure with Toxicity: A Cytotoxicity and Inflammatory Response Study with Human Dermal Fibroblasts and Human Lung Epithelial Cells. *Toxicological Sciences* **2006**, *92* (1), 174-185.
  45. Liao, C.-M.; Chiang, Y.-H.; Chio, C.-P. Assessing the Airborne Titanium Dioxide Nanoparticle-Related Exposure Hazard at Workplace. *Journal of Hazardous Materials* **2009**, *162* (1), 57-65.
  46. Gontier, E.; Ynsa, M.-D.; Biro, T.; Hunyadi, J.; Kiss, B.; Gaspar, K.; Pinheiro, T.; Silva, J.-N.; Filipe, P.; Stachura, J.; Dabros, W.; Reinert, T.; Butz, T.; Moretto, P.; Surleve-Bazeille, J.-E. Is There Penetration of Titania Nanoparticles in Sunscreens through Skin? A Comparative Electron and Ion Microscopy Study. *Nanotoxicology* **2008**, *2* (4), 218-231.
  47. van der Merwe, D.; Tawde, S.; Pickrell, J. A.; Erickson, L. E. Nanocrystalline Titanium Dioxide and Magnesium Oxide *in vitro* Dermal Absorption in Human Skin. *Cutaneous and Ocular Toxicology* **2009**, *28* (2), 78-82.
  48. Warheit, D. B.; Hoke, R. A.; Finlay, C.; Donner, E. M.; Reed, K. L.; Sayes, C. M. Development of a Base Set of Toxicity Tests Using Ultrafine TiO<sub>2</sub> Particles as a Component of Nanoparticle Risk Management. *Toxicology Letters* **2007**, *171*, 99-110.
  49. NanoScale Corporation *NanoActive TiO<sub>2</sub> Safety Testing*. 2010.
  50. Chen, E.; Ruvalcaba, M.; Araujo, L.; Chapman, R.; Chin, W.-C. Ultrafine Titanium Dioxide Nanoparticles Induce Cell Death in Human Bronchial Epithelial Cells. *Journal of Experimental Nanoscience* **2008**, *3* (3), 171-183.
  51. Liao, C.-M.; Chiang, Y.-H.; Chio, C.-P. Model-Based Assessment for Human Inhalation Exposure Risk to Airborne Nano/Fine Titanium Dioxide Particles. *Science of the Total Environment* **2008**, *407* (1), 165-177.
  52. NIOSH *NIOSH Current Intelligence Bulletin: Evaluation of Health Hazard and Recommendations for Occupational Exposure to Titanium Dioxide*. 2005.
  53. Ramsden, C. S.; Smith, T. J.; Shaw, B. J.; Handy, R. D. Dietary Exposure to Titanium Dioxide Nanoparticles in Rainbow Trout, (*Oncorhynchus mykiss*): No Effect on Growth, but Subtle Biochemical Disturbances in the Brain. *Ecotoxicology* **2009**, *18* (7), 939-951.
  54. Lovern, S. B.; Strickler, J. R.; Klaper, R. Behavioral and Physiological Changes in *Daphnia magna* when Exposed to Nanoparticle Suspensions (Titanium Dioxide, Nano-C60, and C60HxC70Hx). *Environmental Science & Technology* **2010**, *41* (12), 4465-4470.
-

- 
55. Jemec, A.; Drobne, D.; Remskar, M.; Sepcic, D.; Tisler, T. Effects of Ingested Nano-Sized Titanium Dioxide on Terrestrial Isopods (*Porcellio scaber*). *Environmental Toxicology* **2008**, *27* (9), 1904-1914.
  56. Handy, R. D. Case Study: Biological Effects of Nanomaterials. 2009.
  57. Wu, B.; Wang, Y.; Sahu, M.; Huang, R.; Feng, X.; Biswas, P.; Tang, Y. Assessment of Toxicity of Metal Oxide Nanoparticles to Microbial Species. Omnipress: 2010.
  58. Environmental Protection Agency *Sampling and Analysis of Nanomaterials in the Environment: A State-of-the-Science Review*; EPA/600/R-08/098; U.S. Environmental Protection Agency: Washington, DC, Sep 18, 08.
  59. Burleson, D. J.; Driessen, M. D.; Penn, R. L. On the characterization of environmental nanoparticles. *Journal of Environmental Science and Health* **2004**, *39* (10), 2707-2753.
  60. Englert, B. C. Nanomaterials and the environment: uses, methods and measurement. *Journal of Environmental Monitoring* **2007**, *9*, 1154-1161.
  61. Tiede, K.; Hasselov, M.; Breitbarth, E.; Chaudhry, Q.; Boxall, A. B. A. Considerations for Environmental Fate and Ecotoxicity Testing to Support Environmental Risk Assessments for Engineered Nanoparticles. *Journal of Chromatography A* **2009**, *216*, 503-509.
  62. Nowack, B. Heavy Metals in the Environment. Wang, L. K., Chen, J. P., Hung, Y.-T., Shamma, N. K., Eds.; CRC Press: 2009.
  63. Hochella, M. F.; Moore, J. N.; Putnis, C. V.; Putnis, A.; Kasama, T.; Eberl, D. D. Direct observation of heavy metal-mineral association from the Clark Fork River Superfund Complex: Implications for metal transport and bioavailability. *Geochimica et Cosmochimica Acta* **2005**, *69*, 1651-1663.
  64. Hochella, M. F.; Moore, J. N.; Golla, U.; Putnis, A. A TEM study of samples from acid mine drainage systems: Metal-mineral association with implications for transport. *Geochimica et Cosmochimica Acta* **1999**, *63*, 3395-3406.
  65. Noack, A.; Grant, C. Colloid Movement Through Stable Soils of Low Cation-Exchange Capacity. *Environmental Science and Technology* **2000**, *32*, 2490-2497.
  66. Gimbert, L.; Haygarth PM; Beckett R; Worsfold PJ The Influence of Sample Preparation on Observed Particle Size Distributions for Contrasting Soil Suspensions using Flow Field-Flow Fractionation. *Environmental Chemistry* **2006**, *3*, 184-191.
  67. Gimbert LJ; Hamon RE; Casey PS; Worsfold PJ Partitioning and Stability of Engineered ZnO Nanoparticles in Soil Suspensions Using Field-Flow Fractionation. *Environmental Chemistry* **2007**, *4*, 8-10.
  68. Klaine, S.; Alvarez, P.; Batley, F.; Fernandes, T.; Handy, R.; Lyon, D.; Mahendra, S.; McLaughlin, M.; Lead, J. Nanomaterials in the Environment: Behavior, Fate,
-

---

Bioavailability, and Effects. *Environmental Toxicology and Chemistry* **2008**, *27* (9), 1825-1851.

69. Willis, R. C. When Size Matters. *Today's Chemists at Work*, **Jul 1, 2002**, pp 21-24.
70. Quang, C.; Petersen, S. L.; Ducatte, G. R.; Ballou, N. E. Characterization and Separation of Inorganic Fine Particles by Capillary Electrophoresis with an Indifferent Electrolyte System. *Journal of Chromatography A* **1996**, *732*, 377-384.
71. Hasselov, M.; Readman, J. W.; Ranville, J. F.; Tiede, K. Nanoparticle Analysis and Characterization Methodologies in Environmental Risk Assessment of Engineered Nanoparticles. *Ecotoxicology* **2008**, *17* (5), 344-361.
72. Doucet, F.; Lead, J.; Maguire, L.; Achterberg, E.; Millward, G. Visualisation of Natural and Aquatic Colloids and Particles- A Comparison of Conventional High Vacuum and Environmental Scanning Electron Microscopy. *Journal of Environmental Monitoring* **2005**, *7*, 115-121.
73. Waychunas, G.; Kim, C.; Banfield, J. Nanoparticulate oxide minerals in soils and sediments: unique properties and contaminant scavenging mechanisms. *Journal of Nanoparticle Research* **2005**, *7*, 409-433.
74. Gilbert, B.; Guoping, L.; Kim, C. Stable cluster formation in aqueous suspensions of iron oxyhydroxide nanoparticles. *Journal of Colloid and Interface Science* **2007**, *313*, 152-159.
75. Zucker, R. M.; Massaro, E. J.; Sanders, K. M.; Degn, L. L.; Boyes, W. K. Detection of TiO<sub>2</sub> Nanoparticles in Cells by Flow Cytometry. *Cytometry Part A* **2010**, *77A*, 677-685.
76. Wigginton, N. S.; Haus, K. L.; Hochella, M. F., Jr. Aquatic Environmental Nanoparticles. *Journal of Environmental Monitoring* **2007**, *9* (12), 1306-1316.

## **Appendix A**

### **DIALOG® SEARCH RESULTS**

**A-1: POTENTIALLY APPLICABLE TITLES FOR PRODUCTION, USE, DISTRIBUTION, AND DISPOSAL OF NANO-TiO<sub>2</sub>**

**A-2: POTENTIALLY APPLICABLE TITLES FOR EXPOSURE PATHWAYS AND TRANSPORT MECHANISMS**

**A-3: POTENTIALLY APPLICABLE TITLES FOR TOXICOLOGICAL AND ECOLOGICAL EFFECTS OF NANO-TiO<sub>2</sub>**

**A-4: POTENTIALLY APPLICABLE TITLES FOR SAMPLING AND ANALYSIS OF NANO-TiO<sub>2</sub> IN THE ENVIRONMENT**

**A-5: NON-APPLICABLE TITLES**

**Appendix A-1**

**POTENTIALLY RELEVANT TITLES FOR PRODUCTION, USE,  
DISTRIBUTION, AND DISPOSAL OF NANO-TiO<sub>2</sub>**

**Table A-1. Titles Pertaining to the Production, Use, Distribution, and Disposal of Nano-TiO<sub>2</sub>**

	<b>Title</b>	<b>Date</b>	<b>Type of Source</b>	<b>Database Number</b>	<b>Other Information</b>
1	Titania nanotubes could cut solar-cell costs -- Tubes could bump cheap dye cells' conversion efficiency closer to single-crystal silicon	2/6/2006	Article	4	
2	Silver-supported nanometer titanium dioxide antibacterial material	11/26/2005	Article	5	
3	Nanometer titanium dioxide.(Anhui Kena New Material Co. develops nanometer titanium dioxide and inorganic antibiotic titanium dioxide powder)	6/6/2005	Article	6	
4	100 T/A nanometer titanium dioxide project starts construction in Tianjin	3/6/2005	Article	7	
5	Commercial test for the production of nanometer titanium dioxide	11/26/2004	Article	8	
6	Altair Nanomaterials of Reno, Nev., has teamed up with Titanium Metals Corp. of Denver to develop a low-cost manufacturing process for titanium dioxide pellets that can be transformed into titanium metal	3/4/2004	Article	9	
7	Tibet develops nanometer titanium dioxide. (New Products)	7/16/2003	Article	10	
8	Nanometer titanium dioxide production base. (New Product: Brief)	1/26/2003	Article	11	
9	200 T/A nanometer titanium dioxide production line in panzhihua steel corporation starts production. (Project: Newsbrief)	1/6/2003	Article	12	
10	Ti(O.sub.2) makers have big hopes for small particles. (Nanomaterials).(titanium dioxide)(Industry Overview)	12/18/2002	Article	13	
11	Millennium Chemicals Inc. (Europe in Brief).(titanium dioxide)	2/11/2002	Article	14	
12	Sorption of thallium(III) ions from aqueous solutions using titanium dioxide nanoparticles	4/1/2009	Article	151	
13	UV-Blocking Properties of Silica/Titania Hybrid Nanocomposites	3/1/2007	Article	264	

**Table A-1. (Continued)**

	<b>Title</b>	<b>Date</b>	<b>Type of Source</b>	<b>Database Number</b>	<b>Other Information</b>
14	A microporous titania membrane for nanofiltration and pervaporation.	9/3/2004	Article	285	
15	Integrating nanoscale zero-valent iron and titanium dioxide for nutrient removal in stormwater systems	8/1/2008	Article	476	
16	Review of titania nanotubes synthesized via the hydrothermal treatment: Fabrication, modification, and application	12/1/2007	Article	627	
17	Sun protection enhancement of titanium dioxide crystals by the use of carnauba wax nanoparticles: The synergistic interaction between organic and inorganic sunscreens at nanoscale	9/28/2006	Article	707	
18	Nozzle-quenching process for controlled flame synthesis of titania nanoparticles	4/16/2004	Article	890	
19	Titania nanotubes for solar energy and catalysis	2008	Dissertation	962	Northeastern University, Boston, MA
20	Removal of elemental mercury from flue gas using nanostructured silica/titania/vanadia composites	2007	Dissertation	964	University of Florida, Gainesville, FL
21	Photocatalytic degradation of select drinking water pollutants using nano-titanium dioxide catalyst	2008	Dissertation	970	University of Windsor, Ontario, CA
22	Green organic solar cells from a water soluble polymer and nanocrystalline titanium dioxide	2006	Dissertation	980	Virginia Commonwealth University, Richmond, VA
23	Chemistry of titanium dioxide nanoparticles	2006	Dissertation	987	University of Delaware, Newark, DE
24	The removal of sodium dodecylbenzene sulfonate surfactant from water using silica/titania nanorods/nanotubes composite membrane with photocatalytic capability	2006	Article	1038	
25	Nanometer-sized metal deposits on titanium dioxide - potential applications in clean energy production and (...)		Conf P.	1093	Conference: PARTEC 2004 - International Conference for Particle Technology
26	Determination of trace amounts of total dissolved cationic aluminium species in environmental samples by solid phase extraction using nanometer-sized titanium dioxide and atomic spectrometry techniques	11/1/2009	Article	1113	

**Table A-1. (Continued)**

	<b>Title</b>	<b>Date</b>	<b>Type of Source</b>	<b>Database Number</b>	<b>Other Information</b>
27	Progress of organic wastewater photo-degradation with porous mineral/ nanometer titanium dioxide composite material	3/1/2009	Article	1136	
28	Using Ti(O.sub.2) to treat brain cancer: scientists have developed a titanium dioxide-based nanomaterial that kills cancer cells and leaves healthy cells unharmed.	10/1/2009	Article	1209	
29	Nanoscale titanium dioxide protects plastics from sun damage	11/1/2007	Article	1287	
30	Titania nanotubes and natural dye build efficient solar cells	4/1/2006	Article	1313	
31	The mechanisms of uranium removal from water by iron oxyhydroxides, nanocrystalline titanium dioxide, and elemental iron	6/25/1905	Dissertation	1005	Stevens Institute of Technology, Hoboken, NJ
32	Progress on fabrication, modification and applications of titania nanotube Arrays	2007	Article	626	
33	Determination of trace lead in water samples by graphite furnace atomic absorption spectrometry after preconcentration with nanometer titanium dioxide immobilized on silica gel	3/21/2008	Article	592	
34	Decontamination of Sulfur Mustard and Sarin on Titania Nanotubes	8/27/2008	Article	515	
35	Nanoporous titania membranes for permeation and filtration of organic solutions	8/29/2008	Article	511	
36	Degradation and toxicity reduction of textile wastewater using immobilized titania nanophotocatalysis	9/17/2008	Article	492	
37	Injection of nanocrystalline titanium dioxide into porous media for uranium contaminated groundwater remediation	2007	Dissertation	397	Stevens Institute of Technology, Hoboken, NJ
38	Nanomaterials for environmental remediation	8/28/2005	Presentation	153	

**Appendix A-2**

**POTENTIALLY RELEVANT TITLES FOR EXPOSURE PATHWAYS AND  
TRANSPORT MECHANISMS**

**Table A-2. Titles Pertaining to Exposure Pathways and Transport Mechanisms**

	<b>Title</b>	<b>Date</b>	<b>Type of Source</b>	<b>Database Number</b>	<b>Other Information</b>
1	Role of the air-water interface in the retention of TiO <sub>2</sub> nanoparticles in porous media during primary drainage	3/15/2008	Article	49	
2	Assessing the airborne titanium dioxide nanoparticle-related exposure hazard at workplace	2/15/2009	Article	482	
3	Model-based assessment for human inhalation exposure risk to airborne nano/fine titanium dioxide particles	12/15/2008	Article	503	
4	Nano titanium dioxide: friend or foe	4/13/2009	Article	1272	
5	Aggregation and toxicity of titanium dioxide nanoparticles in aquatic environment-A Review	12/1/2009	Article	355	
6	Fate, Transport and Toxicity of Nanomaterials in Drinking Water	5/1/2007	Conf P.	453	Conference: Nanotech 2007
7	Methods for the Prediction of Nanoparticle Fate, Transport and Receptor Exposure in an Aqueous Environment	5/1/2007	Conf P.	456	Conference: Nanotech 2007

**Appendix A-3**

**POTENTIALLY RELEVANT TITLES FOR TOXICOLOGICAL AND  
ECOLOGICAL EFFECTS OF NANO-TiO<sub>2</sub>**

**Table A-3. Titles Pertaining to Toxicological and Ecological Effects of Nano-TiO<sub>2</sub>.**

	Title	Date	Type of Source	Database Number	Other Information
1	Oxidative stress and proinflammatory effects of carbon black and titanium dioxide nanoparticles: role of particle surface area and internalised amount	6/16/2009	Article	25	
2	Hazard reduction for the application of titanium dioxide nanoparticles in environmental technology	3/21/2008	Article	48	
3	Adverse Effects of Titanium Dioxide Nanoparticles on Human Dermal Fibroblasts and How to Protect Cells	2/5/2009	Article	159	
4	Deleterious effects of sunscreen titanium dioxide nanoparticles on DNA. Efforts to limit DNA damage by particle surface modification	5/1/2003	Conf P.	266	Conference: SPIE Conf. Proceedings
5	The safety of nanosized particles in titanium dioxide- and zinc oxide-based sunscreens	10/1/2009	Article	369	
6	Exposure to Titanium Dioxide Nanomaterials Provokes Inflammation of an in Vitro Human Immune Construct	8/19/2009	Article	380	
7	Titanium dioxide nanoparticles induce oxidative stress and DNA-adduct formation but not DNA-breakage in human lung cells.	6/21/2009	Article	386	
8	Titanium dioxide nanoparticles induce apoptosis through the JNK/p38-caspase-8-Bid pathway in phytohemagglutinin-stimulated human lymphocytes	6/23/2009	Article	1215	
9	Nanocrystalline titanium dioxide and magnesium oxide in vitro dermal absorption in human skin	6/1/2009	Article	1112	
10	Interaction between titanium dioxide nanoparticles and human serum albumin revealed by fluorescence spectroscopy in the absence of photoactivation	8/1/2009	Article	420	
11	Exposure to titanium dioxide and other metallic oxide nanoparticles induces cytotoxicity on human neural cells and fibroblasts	12/1/2008	Article	469	
12	Ultrafine titanium dioxide nanoparticles induce cell death in human bronchial epithelial cells	9/1/2008	Article	529	
13	Toxicity and interaction of titanium dioxide nanoparticles with microtubule protein	9/1/2008	Article	530	

**Table A-3. (Continued)**

	Title	Date	Type of Source	Database Number	Other Information
14	Correlating Nanoscale Titania Structure with Toxicity: A Cytotoxicity and Inflammatory Response Study with Human Dermal Fibroblasts and Human Lung Epithelial Cells	4/12/2006	Article	732	
15	Titanium dioxide nanoparticle absorbed by hepatoma cells in vitro	5/18/2005	Article	779	
16	Nano-sized titanium dioxide: Effects of gestational exposure	9/1/2009	Conf P.	1072	Conference: 37th Annual Conference of the European Teratology Society
17	Is there penetration of titania nanoparticles in sunscreens through skin? A comparative electron and ion microscopy study	12/1/2008	Article	1120	
18	Titanium dioxide nanoparticles trigger p53-mediated damage response in peripheral blood lymphocytes	6/1/2008	Article	561	
19	Nanometer titanium dioxide and its toxicology progress	2008	Article	1127	
20	Nano titanium dioxide photocatalytic protein tyrosine nitration: A potential hazard of TiO <sub>2</sub> on skin.(Report)	4/11/2008	Article	1229	
21	Aggregation and toxicology of titanium dioxide nanoparticles	4/1/2008	Article	1230	
22	Inhalation Exposure Study of Titanium Dioxide Nanoparticles with a Primary Particle Size of 2 to 5 nm	4/1/2007	Article	681	
23	Nano titanium dioxide exposure standards	2/1/2006	Article	1274	
24	Induction of chronic inflammation in mice treated with titanium dioxide nanoparticles by intratracheal instillation	2009	Article	422	
25	Dietary exposure to titanium dioxide nanoparticles in rainbow trout, ( <i>Oncorhynchus mykiss</i> ): no effect on growth, but subtle biochemical disturbances in the brain	2/26/2009	Article	390	

**Table A-3. (Continued)**

	<b>Title</b>	<b>Date</b>	<b>Type of Source</b>	<b>Database Number</b>	<b>Other Information</b>
26	Maternal exposure to nanoparticulate titanium dioxide during the prenatal period alters gene expression related to brain development in the mouse	7/29/2009	Article	385	
27	Lung injury study by 15 days inhalation exposure of titanium dioxide nanoparticles in rats	9/13/2009	Article	381	
28	Titanium Dioxide (TiO <sub>2</sub> ) Nanoparticles Induce JB6 Cell Apoptosis Through Activation of the Caspase-8/Bid and Mitochondrial Pathways	1/1/2009	Article	354	
29	Titanium Dioxide Nanoparticles Induce DNA Damage and Genetic Instability In vivo in Mice	11/15/2009	Article	352	
30	Bio-effects of Nano-titanium Dioxide on Lungs of Mice	1/1/2009	Article	150	
31	Pulmonary toxicity induced by three forms of titanium dioxide nanoparticles via intra-tracheal instillation in rats	5/10/2009	Article	122	
32	Titanium dioxide produces reactive oxygen species in immortalised brain microglia: implications for nanoparticle neurotoxicity	6/7/2006	Article	75	
33	Behavioural and physiological changes in Daphnia magna when exposed to nanoparticle suspensions (titanium dioxide, nano-carbon 60, and specified fullerene derivative	5/19/2007	Article	63	
34	Nanosize titanium dioxide stimulates reactive oxygen species in brain microglia and damages neurons, in vitro.	11/1/2007	Article	61	
35	Comparative study on the acute and pulmonary toxicity induced by 3 and 20 nanometres titanium dioxide primary particles in mice	6/1/2007	Article	56	
36	Effects of ingested nano-sized titanium dioxide on terrestrial isopods (Porcellio scaber)	4/2/2008	Article	39	
37	Time-dependent translocation and potential impairment on central nervous system by intranasally instilled titanium dioxide nanoparticles	12/1/2005	Article	36	

**Table A-3. (Continued)**

	<b>Title</b>	<b>Date</b>	<b>Type of Source</b>	<b>Database Number</b>	<b>Other Information</b>
38	Comparing fate and effects of three particles of different surface properties: nano-titanium dioxide, pigmentary titanium dioxide and quartz	5/8/2008	Article	29	
39	Aquatic toxicity evaluation of titanium dioxide nanoparticle produced from sludge of titanium tetrachloride flocculation of waste water and sea water	12/25/2008	Article	20	
40	Test Method for Skin Damage of Titania Photocatalyst Nanoparticles in vitro	1/1/2008	Article	211	
41	Energy dispersive X-ray analysis of titanium dioxide nanoparticle distribution after intravenous and subcutaneous injection in mice	7/22/2009	Article	343	
42	In vitro inflammatory response of nanostructured titania, silicon oxide, and polycaprolactone	12/1/2009	Article	357	
43	Genotoxic responses to titanium dioxide nanoparticles and fullerene in gpt delta transgenic MEF cells	1/20/2009	Article	412	

**Appendix A-4**

**POTENTIALLY RELEVANT TITLES FOR SAMPLING AND ANALYSIS OF  
NANO-TiO<sub>2</sub> IN THE ENVIRONMENT**

**Table A-4. Titles Pertaining to the Sampling and Analysis of Nano-TiO<sub>2</sub> in the Environment**

	<b>Title</b>	<b>Date</b>	<b>Type of Source</b>	<b>Database Number</b>	<b>Other Information</b>
1	Aqueous Long-Term Solubility of Titania Nanoparticles and Titanium(IV) Hydrolysis in a Sodium Chloride System Studied by Adsorptive Stripping Voltammetry	10/1/2009	Article	367	
2	Stability of titania nanoparticles in soil suspensions and transport in saturated homogeneous soil columns	4/1/2009	Article	456	
3	Role of particle coating in controlling skin damage photoinduced by titania nanoparticles	1/1/2009	Article	459	
4	Determination of Trace Cadmium in Environmental Samples by Nanometer-Titanium Dioxide Separation/Preconcentration-Graphite Furnace Atomic Absorption Spectroscopy	9/1/2006	Article	682	
5	Influence of analysis method on the size characterization of nano-titania powder	2004	Article	1255	
6	On the characterization of environmental nanoparticles	9/1/2004	Article	278	
7	Dynamic digital image analysis: Emerging technology for particle characterization	2004	Book	521	
8	Novel photocatalytic nanocomposite systems based on anatase TiO <sub>2</sub> for environmental remediation	unknown	Article	226	

**Appendix A-5**

**IRRELEVANT TITLES**

## Appendix A-5. Irrelevant Titles

7/8/1 (Item 1 from file: 6)

Fulltext available through: [Check for PDF Download Availability and Purchase](#)

NTIS

(c) 2009 NTIS, Intl Cpyrgh All Rights Res. All rights reserved.

2369892 **NTIS Accession Number:** PB2007-103793/XAB

**Preparation of Nanocomposites of Alumina and Titania**

Filed 2 Aug 04

**Descriptors:** \*Nanocomposites; \*Titania; \*Alumina; \*Patent applications; Aluminum titanate; Ball milling; Sintering; Plasma jets

**Identifiers:** NTISGPN

**Section Headings:** 71D (Materials Sciences--Ceramics, Refractories, and Glass); 71N (Materials Sciences--Nonferrous Metals and Alloys); 90B (Government Inventions For Licensing--Chemistry)

7/8/2 (Item 2 from file: 6)

Fulltext available through: [Check for PDF Download Availability and Purchase](#)

NTIS

(c) 2009 NTIS, Intl Cpyrgh All Rights Res. All rights reserved.

2237309 **NTIS Accession Number:** ADP012201/XAB

**Sol-Gel Synthesis and Characterization of Neodymium-Ion Doped Nanostructured Titania Thin Films**

Nov 2001

**Descriptors:** \*Thin films; \*Titanium dioxide; \*Neodymium alloys; \*Sol gel processes; Annealing; Grain size; Substrates; Trapping(Charged particles); Quartz; Oxidation; Doping; Photodegradation; Nanostructures

**Identifiers:** Component report; NTISDODXA

**Section Headings:** 49GE (Electrotechnology--General); 71N (Materials Sciences--Nonferrous Metals and Alloys)

7/8/3 (Item 1 from file: 9)

Business & Industry(R)

(c) 2010 Gale/Cengage. All rights reserved.

04329340 Supplier Number: 170414612

**Nanoholes improve the light absorption of Ti(O.sub.2).**

October 2007

**Word Count:** 123

**Company Names:** UNITED STATES DEPARTMENT OF ENERGY BROOKHAVEN NATIONAL LABORATORY

**Industry Names:** Chemical; Inorganic chemicals; Pharmaceutical

**Product Names:** Titanium dioxide (281632); Sunscreen and sunburn remedies (283441)

**Concept Terms:** All product and service information; R&D expenditures

**Geographic Names:** North America (NOAX); United States (USA)

## Appendix A-5. Irrelevant Titles

7/8/15 (Item 13 from file: 9)

Business & Industry(R)

(c) 2010 Gale/Cengage. All rights reserved.

02484007 Supplier Number: 24886087 (USE FORMAT 7 OR 9 FOR FULLTEXT)

**Breakthrough in Nano-grade (TiO.sub.2)**

June 06, 2001

**Word Count:** 158

**Industry Names:** Chemical; Inorganic chemicals

**Product Names:** Titanium dioxide (281632)

**Concept Terms:**

All product and service information; Product development

**Geographic Names:** China (CHI); Pacific Rim (PARX); Southern & Eastern Asia (SSAX)

7/8/16 (Item 1 from file: 19)

Chem.Industry Notes

(c) 2010 Amer.Chem.Soc. All rights reserved.

1589049

**Titandioxid-Nanopartikel sorgen fuer Selbstreinigungseffekt ( Titanium dioxide-nano particles take ca**

**Major Descriptor:** \*nano particle based photo catalytic coating development Germany

**Descriptors:**

Leibniz-Institut fuer Neue Materialien GmbH

**EC=** 3 ( Products and Processes )

**Publication Year:** 2006

7/8/17 (Item 2 from file: 19)

Chem.Industry Notes

(c) 2010 Amer.Chem.Soc. All rights reserved.

1512133

**Nano titanium dioxide**

**Major Descriptor:** \*nano titanium dioxide **production** China

**Descriptors:**

Sichuan Pangzhihua Steel Research Institute

**EC=** 6 ( Market Data )

**Country Code:** 9CHN

**Country Name:** CHINA

**Publication Year:** 2003

7/8/18 (Item 3 from file: 19)

Chem.Industry Notes

(c) 2010 Amer.Chem.Soc. All rights reserved.

1510342

## Appendix A-5. Irrelevant Titles

### **Nano-grade titanium dioxide**

**Major Descriptor:** \*titanium dioxide project China

**Descriptors:**

Anhui Kena New Materials Co. Ltd.

**EC=** 4 ( Resources and Resource Use )

**Country Code:** 9CHN

**Country Name:** CHINA

**Publication Year:** 2002

7/8/21 (Item 3 from file: 31)

World Surface Coatings Abs

(c) 2009 PRA Coat. Tech. Cen. All rights reserved.

00614521 **WSCA Abstract Number:** 09-06095 **WSCA ID Number:** 686095

**Self-cleaning performance of polycarbonate surfaces coated with titanium dioxide nanoparticles.**

**2009**

**Descriptors:** Titanium Dioxide; Nanoparticles; Photoactivity; Plastics; Pretreatment; Adhesion

**Chemical Names:** titanium dioxide; sodium hydroxide; silica; hydroxyl; carboxyl; methylene blue

**Identifiers:** Titanium Dioxide-- nanoparticles, on plastics, adhesion/photoactivity; Nanoparticles-- titanium dioxide, on plastics, adhesion/photoactivity; Photoactivity-- titanium dioxide, nanoparticles on plastics; Plastics-- pretreatment, before titanium dioxide nanoparticles; Pretreatment-- plastics, before titanium dioxide nanoparticles; Adhesion-- titanium dioxide nanoparticles, to plastics

**Additional Terms (Identifiers):** photo-Fries reaction; plastics substrate; photodegradation; UV radiation ; ultraviolet radiation; anti-misting; dye

7/8/22 (Item 4 from file: 31)

World Surface Coatings Abs

(c) 2009 PRA Coat. Tech. Cen. All rights reserved.

00614158 **WSCA Abstract Number:** 09-05732 **WSCA ID Number:** 685732

**Highly stable molecular layers on nanocrystalline anatase titanium dioxide through photochemical grafting.**

**2009**

**Descriptors:** Titanium Dioxide; Grafting

**Chemical Names:** dodecene; methyl 10-undecylenate; anatase; titanium dioxide; water; acetonitrile; oxide; hydroxyl

**Identifiers:** Titanium Dioxide-- anatase, grafting on, & stability; Grafting-- on titanium dioxide, photo-grafting, & stability

**Additional Terms (Identifiers):** solvent; oxide substrate; infrared; IR; X-ray photoelectron spectroscopy; ESCA; electron spectroscopy for chemical analysis; photochemistry; alkene; alpha-olefin; hydrogen ion concentration

## Appendix A-5. Irrelevant Titles

7/8/23 (Item 5 from file: 31)

World Surface Coatings Abs

(c) 2009 PRA Coat. Tech. Cen. All rights reserved.

00613988 **WSCA Abstract Number:** 09-05562 **WSCA ID Number:** 685562

**Ultraviolet-driven reversible switching of a polystyrene/titanium dioxide nanocomposite coating between superhydrophobicity and superhydrophilicity.**

**2009**

**Descriptors:** Hydrophobicity; Hydrophilicity; Titanium Dioxide; Nanoparticles

**Chemical Names:** polystyrene; titanium dioxide; Titanium dioxide; polystyrene; water; metal oxide

**Identifiers:** Hydrophobicity-- high, switching hydrophilicity (high); Hydrophilicity-- high, switching hydrophobicity (high); Titanium Dioxide-- nanoparticles, polystyrene &, hydrophilicity switching; Nanoparticles-- titanium dioxide, polystyrene &, hydrophilicity switching

**Additional Terms (Identifiers):** MW; glass substrate; particle size; wettability; high hydrophobicity; high hydrophilicity; UV radiation; ultraviolet radiation

7/8/24 (Item 6 from file: 31)

World Surface Coatings Abs

(c) 2009 PRA Coat. Tech. Cen. All rights reserved.

00613534 **WSCA Abstract Number:** 09-05108 **WSCA ID Number:** 685108

**Preparation and characterisation of sulphur-doped titanium dioxide nanoparticles: effect of calcination temperature and evaluation of photocatalytic activity.**

**2009**

**Descriptors:** Titanium Dioxide; Photoactivity; Light

**Chemical Names:** Sulphur; titanium dioxide; thiourea; anatase; rutile; methyl orange

**Identifiers:** Titanium Dioxide-- sulphur-doped, photoactivity, visible/ultraviolet; Photoactivity-- titanium dioxide (sulphur-doped), visible/ultraviolet; Light-- visible, photoactivity, titanium dioxide (sulphur-doped)

**Additional Terms (Identifiers):** UV radiation; ultraviolet radiation

7/8/26 (Item 8 from file: 31)

World Surface Coatings Abs

(c) 2009 PRA Coat. Tech. Cen. All rights reserved.

00613033 **WSCA Abstract Number:** 09-04607 **WSCA ID Number:** 684607

**Synthesis and kinetics of graft polymerisation of methyl methacrylate from the reversible addition/fragmentation chain transfer (RAFT) co-ordinated surface of nano-titanium dioxide.**

**2008**

**Descriptors:** Methyl Methacrylate; Grafting; Titanium Dioxide; Nanoparticles; Polymerisation

**Chemical Names:** methyl methacrylate; titanium dioxide; dithioester

**Identifiers:** Methyl Methacrylate-- grafting, on titanium dioxide nanoparticles; Grafting-- methyl methacrylate, on titanium dioxide nanoparticles; Titanium Dioxide-- nanoparticles,

## Appendix A-5. Irrelevant Titles

grafting on, methyl methacrylate; Nanoparticles-- titanium dioxide, grafting on, methyl methacrylate; Polymerisation-- chain transfer, addition/fragmentation (reversible), grafting on titanium dioxide

**Additional Terms (Identifiers):** titanium dioxide nanoparticle; MW

7/8/28 (Item 10 from file: 31)

World Surface Coatings Abs

(c) 2009 PRA Coat. Tech. Cen. All rights reserved.

00611291 **WSCA Abstract Number:** 09-02865 **WSCA ID Number:** 682865

**Synthesis and characterisation of titanium dioxide nanopowders from peroxotitanium solutions.**

**2009**

**Descriptors:** Titanium Dioxide; Nanoparticles

**Chemical Names:** hydrogen peroxide; titanium dioxide

**Identifiers:** Titanium Dioxide-- nanoparticles, manufacture, peroxotitanium/hydrolysis; Nanoparticles-- titanium dioxide, manufacture, peroxotitanium/hydrolysis

**Additional Terms (Identifiers):**

ph; transmission EM; nanoparticle; TGA; thermogravimetry

7/8/30 (Item 12 from file: 31)

World Surface Coatings Abs

(c) 2009 PRA Coat. Tech. Cen. All rights reserved.

00610657 **WSCA Abstract Number:** 09-02231 **WSCA ID Number:** 682231

**Substrate-induced coagulation (SIC) of nano-disperse titanium dioxide in non-aqueous media: the dispersibility and stability of titanium dioxide in N-methyl-2-pyrrolidone.**

**2009**

**Descriptors:** Titanium Dioxide; Coagulation; Nanoparticles

**Chemical Names:** titanium dioxide; sodium bis(2-ethylhexyl) sulphosuccinate; lithium chloride

**Identifiers:** Titanium Dioxide-- coagulation (substrates-induced), in non-aq; Coagulation-- substrates-induced, titanium dioxide, in non-aq; Nanoparticles-- titanium dioxide, coagulation (substrates-induced)

7/8/31 (Item 13 from file: 31)

World Surface Coatings Abs

(c) 2009 PRA Coat. Tech. Cen. All rights reserved.

00610296 **WSCA Abstract Number:** 09-01870 **WSCA ID Number:** 681870

**Synthesis of gadolinium-doped titanium dioxide nanoparticles under mild condition and their photocatalytic activity.**

**2009**

**Descriptors:** Titanium Dioxide; Photoactivity; Dyes; Photodegradation

## Appendix A-5. Irrelevant Titles

**Chemical Names:** Gadolinium; titanium dioxide

**Identifiers:** Titanium Dioxide-- doped, nanoparticles, photoactivity, gadolinium dopants; Photoactivity-- titanium dioxide, doped, nanoparticles; Dyes-- photodegradation, titanium dioxide (doped) nanoparticles; Photodegradation -- dyes, titanium dioxide (doped) nanoparticles

**Additional Terms (Identifiers):** transmission EM; photoactivity; UV radiation; ultraviolet radiation; photodegradation

7/8/32 (Item 14 from file: 31)

World Surface Coatings Abs

(c) 2009 PRA Coat. Tech. Cen. All rights reserved.

00610294 **WSCA Abstract Number:** 09-01868 **WSCA ID Number:** 681868

**Kinetics of sonophotocatalytic degradation of anionic dyes with nano -titanium dioxide. 2009**

**Descriptors:** Dyes; Photodegradation; Titanium Dioxide

**Chemical Names:** anthraquinone; indigo; sulphonate; triphenylmethane; sulphone; azo; titanium dioxide

**Identifiers:** Dyes-- degradation, photoactives/sono, kinetics; Photodegradation-- dyes, titanium dioxide, sono &, kinetics; Titanium Dioxide-- photoactivity, dyes, sono &, kinetics

**Additional Terms (Identifiers):** ultrasonics; photoactivity

7/8/33 (Item 15 from file: 31)

World Surface Coatings Abs

(c) 2009 PRA Coat. Tech. Cen. All rights reserved.

00610288 **WSCA Abstract Number:** 09-01862 **WSCA ID Number:** 681862

**Preparation and photocatalytic activity of rare earth-doped titanium dioxide nanoparticles. 2009**

**Descriptors:** Titanium Dioxide; Photoactivity; Photodegradation; Dyes

**Chemical Names:** oxide; sulphate; nitrate; acetate; azo; sulphonate; rare earth; titanium dioxide; lanthanum; cerium; praseodymium; samarium; neodymium ; europium; dysprosium; gadolinium

**Identifiers:** Titanium Dioxide-- nanoparticles, doped, rare earths/photoactivity; Photoactivity-- light (visible), titanium dioxide (doped) nanoparticles); Photodegradation-- dyes, titanium dioxide (doped) nanoparticles; Dyes-- photodegradation, titanium dioxide (doped) nanoparticles

**Additional Terms (Identifiers):** photoactivity; photocatalyst; sulphonated azo dye

7/8/34 (Item 16 from file: 31)

World Surface Coatings Abs

(c) 2009 PRA Coat. Tech. Cen. All rights reserved.

00610147 **WSCA Abstract Number:** 09-01721 **WSCA ID Number:** 681721

**Markedly controllable adhesion of superhydrophobic sponge-like nanostructure titanium dioxide films.**

## Appendix A-5. Irrelevant Titles

**2008**

**Descriptors:** Titanium Dioxide; Hydrophobicity; **Water**

**Chemical Names:** fluorosilane; fluoro; nitrocellulose; water; titanium dioxide; methanol; nitro; hydrogen; silanol; silane

**Identifiers:** Titanium Dioxide-- sponge-like, hydrophobicity/water drops adhesion; Hydrophobicity-- titanium dioxide (sponge-like); Water-- drops, adhesion, titanium dioxide/nitrocellulose

7/8/35 (Item 17 from file: 31)

World Surface Coatings Abs

(c) 2009 PRA Coat. Tech. Cen. All rights reserved.

00609678 **WSCA Abstract Number:** 09-01252 **WSCA ID Number:** 681252

**Size effect of titanium dioxide/silica nano-hybrid particle.**

**2009**

**Descriptors:** Silica; Nanoparticles; Titanium Dioxide

**Chemical Names:** anatase

**Identifiers:** Silica-- nanoparticles, coated by titanium dioxide; Nanoparticles-- silica, coated by titanium dioxide; Titanium Dioxide-- coatings, on silica nanoparticles

**Additional Terms (Identifiers):** UV/visible spectroscopy

7/8/37 (Item 19 from file: 31)

World Surface Coatings Abs

(c) 2009 PRA Coat. Tech. Cen. All rights reserved.

00609080 **WSCA Abstract Number:** 09-00654 **WSCA ID Number:** 680654

**Synthesis and photocatalytic activity of stable nanocrystalline titanium dioxide with high crystallinity and large surface area.**

**2009**

**Descriptors:** Titanium Dioxide; Photoactivity; Nanoparticles; Photodegradation

**Chemical Names:** ammonium; titanium dioxide; cetyltrimethylammonium bromide; ammonia; anatase; rutile; methylene blue; phenol

**Identifiers:** Titanium Dioxide-- photoactivity, nanoparticles, manufacture/characterisation/activity; Photoactivity-- titanium dioxide, nanoparticles; Nanoparticles-- titanium dioxide, photoactivity; Photodegradation-- dyes, titanium dioxide

**Additional Terms (Identifiers):** ESCA; electron spectroscopy for chemical analysis; photoactivity; nanoparticle; dye

7/8/38 (Item 20 from file: 31)

World Surface Coatings Abs

(c) 2009 PRA Coat. Tech. Cen. All rights reserved.

00609054 **WSCA Abstract Number:** 09-00628 **WSCA ID Number:** 680628

**Synthesis and characterisation of 2-methoxy-5-(2'-ethylhexyloxy)-p-phenylene vinylene/nano-sized titanium dioxide hybrids prepared via in situ sol/gel reaction.**

**2008**

**Descriptors:** Polyphenylenevinylene; Titanium Dioxide; Inorganic Compounds

## Appendix A-5. Irrelevant Titles

**Identifiers:** Polyphenylenevinylene-- hybrids (inorg/org), titanium dioxide &; Titanium Dioxide-- hybrids (inorg/org), polyphenylenevinylene &; Inorganic Compounds-- hybrids (inorg/org), titanium dioxide/polyphenylenevinylene

**Additional Terms (Identifiers):** MW; SEM; MEH-PPV

7/8/40 (Item 22 from file: 31)

World Surface Coatings Abs

(c) 2009 PRA Coat. Tech. Cen. All rights reserved.

00607841 **WSCA Abstract Number:** 08-06844 **WSCA ID Number:** 666844

**Visible light-induced electron transfer process over nitrogen-doped titanium dioxide nanocrystals prepared by oxidation of titanium nitride.**

**2008**

**Descriptors:** Titanium Dioxide; Photoactivity; Light; Toluene

**Chemical Names:** Nitrogen; titanium dioxide; anatase; rutile; titanium nitride; toluene

**Identifiers:** Titanium Dioxide-- doped, by nitrogen, photoactivity, light (visible); Photoactivity-- titanium dioxide (doped), light (visible); Light-- visible, photoactivity, titanium dioxide (doped); Toluene-- photodegradation, titanium dioxide (doped), light (visible)

**Additional Terms (Identifiers):** photoactivity; photodegradation; ESCA; electron spectroscopy for chemical analysis

7/8/41 (Item 23 from file: 31)

World Surface Coatings Abs

(c) 2009 PRA Coat. Tech. Cen. All rights reserved.

00607840 **WSCA Abstract Number:** 08-06843 **WSCA ID Number:** 666843

**Effects of different acids on the preparation of titanium dioxide nanostructure in liquid media at low temperature.**

**2008**

**Descriptors:** Titanium Dioxide; Phase Behaviour

**Chemical Names:** titanium dioxide; hydrochloric acid; nitric acid; rutile; sulphuric acid; anatase

**Identifiers:** Titanium Dioxide-- manufacture of, titanite dissolution/precipitation, phase formation/morphology; Phase Behaviour-- titanium dioxide, titanite dissolution/precipitation

**Additional Terms (Identifiers):** transmission EM

7/8/42 (Item 24 from file: 31)

World Surface Coatings Abs

(c) 2009 PRA Coat. Tech. Cen. All rights reserved.

00607835 **WSCA Abstract Number:** 08-06838 **WSCA ID Number:** 666838

**Study of photocatalysis under ultraviolet plus visible two-beam light irradiation using undoped nano-titanium dioxide.**

**2008**

**Descriptors:**

## Appendix A-5. Irrelevant Titles

Photoactivity; Titanium Dioxide; Light; Dyes

**Chemical Names:** methyl orange; phenol

**Identifiers:** Photoactivity-- titanium dioxide, ultraviolet/light (visible) combination; Titanium Dioxide-- photoactivity, ultraviolet/light (visible) combination; Light-- visible, photoactivity, combination ultraviolet; Dyes-- photodegradation, titanium dioxide, ultraviolet/visible &

**Additional Terms (Identifiers):** dye; photodegradation; photoactivity; photocatalyst

7/8/43 (Item 25 from file: 31)

World Surface Coatings Abs

(c) 2009 PRA Coat. Tech. Cen. All rights reserved.

00607219 **WSCA Abstract Number:** 08-06222 **WSCA ID Number:** 666222

**Preparation of ligand-free titanium dioxide (anatase) nanoparticles through a non-aqueous process and their surface functionalisation.**

**2008**

**Descriptors:** Titanium Dioxide; Nanoparticles

**Chemical Names:** dopamine; titanium tetrachloride; ethanol; Titanium ethoxide; titanium tetrachloride; benzyl alcohol; anatase; catechol

**Identifiers:** Titanium Dioxide-- anatase, nanoparticles, manufacture; Nanoparticles-- titanium dioxide, anatase, manufacture

**Additional Terms (Identifiers):** pH; zeta potential; electron microscopy; EM; X-ray photoelectron spectroscopy; XPS; electron spectroscopy for chemical analysis; ESCA

7/8/44 (Item 26 from file: 31)

World Surface Coatings Abs

(c) 2009 PRA Coat. Tech. Cen. All rights reserved.

00605985 **WSCA Abstract Number:** 08-04988 **WSCA ID Number:** 664988

**Preparation and visible light-driven photoelectrocatalytic properties of boron-doped titanium dioxide nanotubes.**

**2008**

**Descriptors:** Photoactivity; Titanium Dioxide; Dyes; Degradation; Nanoparticles; Light; Photoactivity

**Chemical Names:** boron; titanium dioxide; oxalic acid; ammonium fluoride; methyl orange

**Identifiers:** Photoactivity-- electrical potential &, titanium dioxide nanotubes (doped); Titanium Dioxide-- nanotubes (doped), photoactivity, electrical potential &; Dyes-- degradation, photoactives/electrical potential; Degradation-- dyes, photoactives/electrical potential; Nanoparticles-- nanotubes, titanium dioxide, doping/photoelectrocatalytic; Light-- visible, photoactivity; Photoactivity-- light (visible)

**Additional Terms (Identifiers):** photoactivity; UV spectroscopy; ultraviolet spectroscopy; dye photodegradation; electrochemistry; electrical potential

7/8/46 (Item 28 from file: 31)

World Surface Coatings Abs

(c) 2009 PRA Coat. Tech. Cen. All rights reserved.

## Appendix A-5. Irrelevant Titles

00604776 **WSCA Abstract Number:** 08-03779 **WSCA ID Number:** 663779

**Single nanocrystals of anatase-type titanium dioxide prepared from layered titanate nanosheets: formation mechanism and characterisation of surface properties.**  
**2007**

**Descriptors:** Titanium Dioxide; Photoactivity; Titanates; Photodegradation; Dyes

**Chemical Names:** tetrabutylammonium hydroxide; propylamine; ammonium; dipyrityl; potassium; lithium; titanate; anatase; titanium dioxide; rutile; methylene blue; ruthenium; thiocyanate

**Identifiers:** Titanium Dioxide-- anatase, nanocrystals from titanates nano-sheets;

Photoactivity-- titanium dioxide, from titanates; Titanates-- titanium dioxide from;

Photodegradation-- dyes, titanium dioxide; Dyes-- photodegradation, titanium dioxide

**Additional Terms (Identifiers):** adsorption; Brunauer-Emmett-Teller; BET; nanoparticle; hydrogen ion concentration

7/8/47 (Item 29 from file: 31)

World Surface Coatings Abs

(c) 2009 PRA Coat. Tech. Cen. All rights reserved.

00604760 **WSCA Abstract Number:** 08-03763 **WSCA ID Number:** 663763

**Microstructure characterisation and photocatalytic activity of mesoporous titanium dioxide films with ultrafine anatase nanocrystallites.**  
**2008**

**Descriptors:** Titanium Dioxide; Porosity; Photoactivity

**Chemical Names:** titanium dioxide; anatase; creatinine

**Identifiers:** Titanium Dioxide-- porosity, formation presence surfactants, photoactivity;

Porosity-- titanium dioxide, formation presence surfactants, photoactivity ; Photoactivity-- titanium dioxide, porosity/formation presence surfactants

**Additional Terms (Identifiers):** borosilicate glass substrate; transmission EM; ultraviolet/visible spectroscopy; photoactivity; photocatalyst; porosity; X-ray diffraction ; XRD; scanning electron microscopy; SEM; high resolution-transmission electron microscopy; UV/visible spectroscopy; nitrogen adsorption/desorption isotherm analysis

7/8/50 (Item 32 from file: 31)

World Surface Coatings Abs

(c) 2009 PRA Coat. Tech. Cen. All rights reserved.

00604316 **WSCA Abstract Number:** 08-03319 **WSCA ID Number:** 663319

**Synthesis and properties of functional composites formed from a responsive polymer and titanium dioxide nanoparticles.**  
**2007**

**Descriptors:** Microgels; Titanium Dioxide; Nanoparticles

**Chemical Names:** acrylic acid; titanium dioxide; polyacrylic acid; N-isopropylacrylamide

**Identifiers:** Microgels-- polymers, titanium dioxide nanoparticles immobilise; Titanium

Dioxide-- nanoparticles, immobilisation by microgels; Nanoparticles-- titanium dioxide, immobilisation by microgels

**Additional Terms (Identifiers):** waste water remediation

## Appendix A-5. Irrelevant Titles

7/8/51 (Item 33 from file: 31)

World Surface Coatings Abs

(c) 2009 PRA Coat. Tech. Cen. All rights reserved.

00604153 **WSCA Abstract Number:** 08-03156 **WSCA ID Number:** 663156

**Dispersion stability of titanium dioxide nanoparticles covered with silicon oxide monolayers in water.**

**2007**

**Descriptors:** Titanium Dioxide; Nanoparticles; Silicon Oxides; Titanium Dioxide; Siloxanes; Photoactivity

**Chemical Names:** titanium dioxide; 1,3,5,7-tetramethylcyclotetrasiloxane; silicon-29; siloxane

**Identifiers:** Titanium Dioxide-- nanoparticles, silicon oxides monolayers on; Nanoparticles-- titanium dioxide, silicon oxides monolayers; Silicon Oxides-- layers, on titanium dioxide; Titanium Dioxide-- treatment by, siloxanes then photo-oxidation; Siloxanes-- treatment with, titanium dioxide, then photo-oxidation; Photoactivity-- titanium dioxide, siloxanes on, photo-oxidation to oxides

**Additional Terms (Identifiers):** diffuse reflectance FTIR; silicon-29 NMR; dispersibility

7/8/52 (Item 34 from file: 31)

World Surface Coatings Abs

(c) 2009 PRA Coat. Tech. Cen. All rights reserved.

00603562 **WSCA Abstract Number:** 08-02565 **WSCA ID Number:** 662565

**Titanium dioxide nanoparticles and nanoparticle suspensions and methods of making the same.**

**Publication Year: 2008**

**Descriptors:** Titanium Dioxide; Nanoparticles; Dispersants

**Chemical Names:** titanium dioxide

**Identifiers:** Titanium Dioxide-- nanoparticles, manufacture, particle size (controlled); Nanoparticles-- titanium dioxide, manufacture, particle size (controlled); Dispersants-- titanium dioxide nanoparticles manufacture presence

**Additional Terms (Identifiers):** dispersant

7/8/53 (Item 35 from file: 31)

World Surface Coatings Abs

(c) 2009 PRA Coat. Tech. Cen. All rights reserved.

00603410 **WSCA Abstract Number:** 08-02413 **WSCA ID Number:** 662413

**Photodegradation of nitrogen oxides by nano-titanium dioxide: role of morphological and structural features of the titanium dioxide materials.**

**2007**

**Descriptors:** Titanium Dioxide; Photoactivity; Nitrogen Oxides; Toluene; Titanium Dioxide; Photoactivity

**Company Names:** Evonik

**Brand/Product Names:** P-25

**Chemical Names:** titanium dioxide; anatase; brookite; rutile; nitrogen oxide; Toluene

## Appendix A-5. Irrelevant Titles

**Identifiers:** Titanium Dioxide-- photoactivity, factors/nitrogen oxides; Photoactivity-- titanium dioxide, factors/nitrogen oxides; Nitrogen Oxides-- photodegradation, titanium dioxide; Toluene-- photodegradation, titanium dioxide; Titanium Dioxide-- photoactivity, toluene; Photoactivity-- titanium dioxide, toluene &

**Additional Terms (Identifiers):** HPL; photoactivity; photocatalyst; air pollution control; photodegradation; nanoparticle

7/8/54 (Item 36 from file: 31)

World Surface Coatings Abs

(c) 2009 PRA Coat. Tech. Cen. All rights reserved.

00602332 **WSCA Abstract Number:** 08-01335 **WSCA ID Number:** 661335

**Titanium dioxide nanostructured films on mica using liquid phase.**

**2008**

**Descriptors:** Titanium Dioxide; Mica; Titanium Tetrafluoride

**Chemical Names:** Titanium dioxide; mica; titanium tetrafluoride

**Identifiers:** Titanium Dioxide-- films, on mica, deposition, growth rates/porosity etc; Mica-- deposition on, titanium dioxide; Titanium Tetrafluoride-- hydrolysis etc, films deposition on mica

**Additional Terms (Identifiers):** mica substrate; hydrogen ion concentration; glass substrate

7/8/55 (Item 37 from file: 31)

World Surface Coatings Abs

(c) 2009 PRA Coat. Tech. Cen. All rights reserved.

00602329 **WSCA Abstract Number:** 08-01332 **WSCA ID Number:** 661332

**Preparation and characterisation of titanium dioxide and polymer nanocomposite films with high refractive index.**

**2007**

**Descriptors:** Nanocomposites; Titanium Dioxide; Refractive Index

**Chemical Names:** bisphenol A; epichlorohydrin; epoxy resin; titanium dioxide; styrene; maleic anhydride; carboxylic acid; amine

**Identifiers:** Nanocomposites-- titanium dioxide/polymers, manufacture/refractive index; Titanium Dioxide-- nanocomposites, refractive index etc; Refractive Index -- nanocomposites, titanium dioxide/polymers

**Additional Terms (Identifiers):** transmission EM; TGA

7/8/57 (Item 39 from file: 31)

World Surface Coatings Abs

(c) 2009 PRA Coat. Tech. Cen. All rights reserved.

00601031 **WSCA Abstract Number:** 08-00034 **WSCA ID Number:** 660034

**Synthesis and infrared emissivity study of collagen-graft-polymethyl methacrylate/titanium dioxide-coated silver nanocomposite.**

**2007**

## Appendix A-5. Irrelevant Titles

**Descriptors:** Infrared; Nanocomposites; Titanium Dioxide; Silver; Collagen; Methyl Methacrylate; Nanoparticles

**Chemical Names:** collagen; polymethyl methacrylate; titanium dioxide; silver; silver nitrate; hydrazine; titanium isopropoxide

**Identifiers:** Infrared-- emissivity, nanocomposites, collagen/acrylics/oxide-coated silver; Nanocomposites-- infrared emissivity, collagen/acrylics/oxide-coated silver; Titanium Dioxide-- coatings, on silver, collagen/acrylics & ; Silver-- nanoparticles (coated), by titanium dioxide; Collagen-- grafting on, methyl methacrylate, nanocomposites; Methyl Methacrylate-- grafting, on collagen, nanocomposites; Nanoparticles-- silver, coated by titanium dioxide

7/8/58 (Item 40 from file: 31)

World Surface Coatings Abs

(c) 2009 PRA Coat. Tech. Cen. All rights reserved.

00601023 **WSCA Abstract Number:** 08-00026 **WSCA ID Number:** 660026

**Synthesis of structured titanium dioxide from carbonaceous templates. Preparation of supported nanoscale titanium dioxide particles.**

**2007**

**Descriptors:** Titanium Dioxide; Titanium Dioxide; Nanoparticles; Carbon Fibres

**Chemical Names:** Titanium dioxide; titanium tetrachloride; oxide; carbon; phosphorous oxychloride

**Identifiers:** Titanium Dioxide-- by chlorides adsorption, then substrates decomposition; Titanium Dioxide-- nanoparticles, on carbon fibres; Nanoparticles-- titanium dioxide, on carbon fibres; Carbon Fibres-- titanium dioxide nanoparticles on

7/8/59 (Item 41 from file: 31)

World Surface Coatings Abs

(c) 2009 PRA Coat. Tech. Cen. All rights reserved.

00601002 **WSCA Abstract Number:** 08-00005 **WSCA ID Number:** 660005

**Photocatalytic degradation of methyl orange in aqueous suspension of mesoporous titanium dioxide nanoparticles.**

**2007**

**Descriptors:** Photoactivity; Titanium Dioxide; Dyes; Photodegradation; Nanoparticles

**Chemical Names:** methyl orange; titanium dioxide

**Identifiers:** Photoactivity-- titanium dioxide, mesostructures, dyes degradation; Titanium Dioxide-- nanoparticles, mesostructures, photoactivity, dyes degradation; Dyes-- photodegradation, titanium dioxide, mesostructures; Photodegradation-- dyes, titanium dioxide, mesostructures; Nanoparticles-- titanium dioxide, photoactivity

**Additional Terms (Identifiers):** photoactivity; ultraviolet radiation; UV radiation; hydrogen ion concentration; dye

7/8/60 (Item 42 from file: 31)

World Surface Coatings Abs

## Appendix A-5. Irrelevant Titles

(c) 2009 PRA Coat. Tech. Cen. All rights reserved.

00600817 **WSCA Abstract Number:** 07-07588 **WSCA ID Number:** 647588

**Synthesis of a perpendicular titanium dioxide nano-sheet film with the superhydrophilic property without ultraviolet (UV) irradiation.**

**2007**

**Descriptors:** Titanium Dioxide; Hydrophilicity; Titanium Dioxide

**Chemical Names:** titanium; urea; ammonia; ammonium titanate; oxide; water

**Identifiers:** Titanium Dioxide-- nano-sheets, growth (perpendicular) from substrates; Hydrophilicity-- high, titanium dioxide nano-sheets (perpendicular); Titanium Dioxide-- nano-sheets, hydrophilicity

**Additional Terms (Identifiers):** hydrophobicity; X-ray photoelectron spectroscopy; ESCA; electron spectroscopy for chemical analysis; titanium substrate

7/8/65 (Item 47 from file: 31)

World Surface Coatings Abs

(c) 2009 PRA Coat. Tech. Cen. All rights reserved.

00597819 **WSCA Abstract Number:** 07-04590 **WSCA ID Number:** 644590

**Photostabilisation of cationic ultraviolet-cured coatings in the presence of nano-titanium dioxide.**

**2007**

**Descriptors:** Ultraviolet-curable Coatings; Titanium Dioxide; Nanoparticles; Ultraviolet Absorbers; Sols

**Company Names:** Degussa

**Brand/Product Names:** P-25

**Chemical Names:** epoxy siloxane; epoxy silane; titanate; iodonium; titanium dioxide

**Identifiers:** Ultraviolet-curable Coatings-- ultraviolet absorbers, titanium dioxide nanoparticles; Titanium Dioxide-- nanoparticles, ultraviolet absorbers, ultraviolet-curable; Nanoparticles-- titanium dioxide, ultraviolet absorbers, ultraviolet-curable; Ultraviolet Absorbers-- ultraviolet-curable, titanium dioxide nanoparticles; Sols-- sols/gels processes, titanium dioxide

**Additional Terms (Identifiers):** FTIR; UV absorber; ultraviolet absorber

7/8/66 (Item 48 from file: 31)

World Surface Coatings Abs

(c) 2009 PRA Coat. Tech. Cen. All rights reserved.

00596660 **WSCA Abstract Number:** 07-03431 **WSCA ID Number:** 643431

**Fabrication and photovoltaic properties of self-assembled sulphonated polyaniline/titanium dioxide nanocomposite ultrathin films.**

**2007**

**Descriptors:** Nanocomposites; Titanium Dioxide; Aniline; Photochemistry

**Chemical Names:** sulphonate; polyaniline; titanium dioxide; aniline

**Identifiers:** Nanocomposites-- titanium dioxide/aniline polymers (sulphonated); Titanium Dioxide-- nanocomposites, aniline polymers (sulphonated) &; Aniline-- polymers (sulphonated), nanocomposites, titanium dioxide &; Photochemistry-- photocurrents, nanocomposites, polymers/oxides

## Appendix A-5. Irrelevant Titles

7/8/67 (Item 49 from file: 31)

World Surface Coatings Abs

(c) 2009 PRA Coat. Tech. Cen. All rights reserved.

00596648 **WSCA Abstract Number:** 07-03419 **WSCA ID Number:** 643419

**Capillary condensation on to titanium dioxide nanoparticle agglomerates.**

**2007**

**Descriptors:** Titanium Dioxide; Nanoparticles; Silica; Ethyl Silicate

**Chemical Names:** ethyl silicate; titanium dioxide; oxide; silica; tetraethyl silicate

**Identifiers:** Titanium Dioxide-- nanoparticles, interconnections by silica condensation; Nanoparticles-- titanium dioxide, interconnections by silica condensation; Silica-- condensation, titanium dioxide nanoparticles interconnections; Ethyl Silicate-- condensation/hydrolysis, titanium dioxide nanoparticles interconnections

**Additional Terms (Identifiers):** X-ray photoelectron spectroscopy; ESCA; electron spectroscopy for chemical analysis; BET; electron microscopy; EM; oxide substrate; mechanical properties; agglomerate; organic silicate; hydrolysis

7/8/68 (Item 50 from file: 31)

World Surface Coatings Abs

(c) 2009 PRA Coat. Tech. Cen. All rights reserved.

00596008 **WSCA Abstract Number:** 07-02779 **WSCA ID Number:** 642779

**Preparation and characterisation of acrylic resin/titanium dioxide hybrid nanocomposite coatings by photopolymerisation and sol/gel process.**

**2006**

**Descriptors:** Nanocomposites; Titanium Dioxide; Siloxanes, Unsaturated; Photopolymerisation

**Chemical Names:** isopropyl titanate; acrylic; titanium dioxide; siloxane; acrylate; titanium tetraisopropoxide

**Identifiers:** Nanocomposites-- titanium dioxide/siloxanes (unsatd), coatings; Titanium Dioxide-- nanocomposites, from titanates/siloxanes (unsatd); Siloxanes, Unsaturated-- photopolymerisation, titanates condensation & Photopolymerisation-- siloxanes (unsatd), titanates condensation &

**Additional Terms (Identifiers):** unsaturated siloxane; AFM

7/8/69 (Item 51 from file: 31)

World Surface Coatings Abs

(c) 2009 PRA Coat. Tech. Cen. All rights reserved.

00596006 **WSCA Abstract Number:** 07-02777 **WSCA ID Number:** 642777

**Optimum conditions of water/oil microemulsion for preparation of titanium dioxide nanoparticles.**

**2007**

**Descriptors:** Titanium Dioxide; Nanoparticles; Titanates

**Chemical Names:** tetraisopropyl titanate; isopropyl titanate; sodium bis(2-ethylhexyl)

## Appendix A-5. Irrelevant Titles

sulphosuccinate; hydroxypropylcellulose; sodium dodecyl sulphate

**Identifiers:** Titanium Dioxide-- nanoparticles, from titanates, microemulsions methods; Nanoparticles-- titanium dioxide, from titanates, microemulsions methods; Titanates-- hydrolysis, titanium dioxide nanoparticles manufacture

**Additional Terms (Identifiers):** sol/gel process; surfactant

7/8/70 (Item 52 from file: 31)

World Surface Coatings Abs

(c) 2009 PRA Coat. Tech. Cen. All rights reserved.

00595994 **WSCA Abstract Number:** 07-02765 **WSCA ID Number:** 642765

**Optical efficiency and nitrogen oxides reduction properties of photocatalytic titanium dioxide nanoparticles activated by ultraviolet.**

**2007**

**Descriptors:** Titanium Dioxide; Nanoparticles; Photoactivity; Sols; Nitrogen Oxides

**Brand/Product Names:** Nanomat; Nanotext

**Chemical Names:** anatase; Titanium dioxide; methylene blue; nitrogen oxide

**Identifiers:** Titanium Dioxide-- nanoparticles, sols/gels, photoactivity; Nanoparticles -- titanium dioxide, sols/gels, photoactivity; Photoactivity-- titanium dioxide, nanoparticles, sols/gels; Sols-- sols/gels systems, titanium dioxide nanoparticles; Nitrogen Oxides-- reduction, titanium dioxide nanoparticles

**Additional Terms (Identifiers):** 3-D; near-ultraviolet; accelerated weathering; natural weathering; decorative coating; photodegradation; photoactivity; photocatalyst

7/8/72 (Item 54 from file: 31)

World Surface Coatings Abs

(c) 2009 PRA Coat. Tech. Cen. All rights reserved.

00593236 **WSCA Abstract Number:** 07-00007 **WSCA ID Number:** 640007

**Surface modification on nanoscale titanium dioxide by radiation: preparation and characterisation.**

**2006**

**Descriptors:** Titanium Dioxide; Grafting; Electron Beams; Nanoparticles; Methyl Methacrylate

**Chemical Names:** acrylic; titanium dioxide; anatase; rutile; methyl methacrylate

**Identifiers:** Titanium Dioxide-- nanoparticles, grafting on, electron beams; Grafting-- on titanium dioxide, nanoparticles, electron beams; Electron Beams-- grafting, on titanium dioxide; Nanoparticles-- titanium dioxide, grafting on; Methyl Methacrylate-- grafting, on titanium dioxide

**Additional Terms (Identifiers):** ESCA; electron spectroscopy for chemical analysis; hydrophilicity; hydrophobicity

7/8/73 (Item 55 from file: 31)

World Surface Coatings Abs

(c) 2009 PRA Coat. Tech. Cen. All rights reserved.

00592527 **WSCA Abstract Number:** 06-07705 **WSCA ID Number:** 627705

## Appendix A-5. Irrelevant Titles

### **Effects of boron doping on photocatalytic activity and microstructure of titanium dioxide nanoparticles.**

**2006**

**Descriptors:** Titanium Dioxide; Nanoparticles; Photoactivity

**Chemical Names:** boric oxide; Boron; titanium dioxide; anatase; rutile; nicotinamide adenine dinucleotide

**Identifiers:** Titanium Dioxide-- doped, nanoparticles, microstructure/photoactivity; Nanoparticles-- titanium dioxide (doped), microstructure/photoactivity; Photoactivity-- titanium dioxide (doped), NADH (reduced) regeneration

**Additional Terms (Identifiers):** photoactivity; photocatalyst; ESCA; electron spectroscopy for chemical analysis; Fourier transform infrared spectroscopy; UV spectroscopy; ultraviolet spectroscopy; calcination

7/8/74 (Item 56 from file: 31)

World Surface Coatings Abs

(c) 2009 PRA Coat. Tech. Cen. All rights reserved.

00591831 **WSCA Abstract Number:** 06-07009 **WSCA ID Number:** 627009

### **Fabrication and shape-evolution of nanostructured titanium dioxide via a sol/solvothermal process based on benzene/water interfaces.**

**2006**

**Descriptors:** Titanium Dioxide; Nanoparticles

**Chemical Names:** butyl titanate; titanium dioxide; titanium tetrachloride; tetrabutyl titanate

**Identifiers:** Titanium Dioxide-- nanoparticles, from sols, solvothermal; Nanoparticles-- titanium dioxide, from sols, solvothermal

7/8/76 (Item 58 from file: 31)

World Surface Coatings Abs

(c) 2009 PRA Coat. Tech. Cen. All rights reserved.

00591160 **WSCA Abstract Number:** 06-06338 **WSCA ID Number:** 626338

### **Hydrothermal synthesis, characterisation, and photocatalytic performance of silica-modified titanium dioxide nanoparticles.**

**2005**

**Descriptors:** Titanium Dioxide; Photoactivity; Nanoparticles; Silica

**Chemical Names:** Silica; anatase; rutile

**Identifiers:** Titanium Dioxide-- modified, by silica, & photoactivity; Photoactivity -- titanium dioxide (modified), by silica; Nanoparticles-- titanium dioxide (modified), by silica; Silica-- titanium dioxide modified by

**Additional Terms (Identifiers):** FTIR; ESCA; electron spectroscopy for chemical analysis; transmission EM ; UV spectroscopy; ultraviolet spectroscopy; photocatalyst; photoactivity; calcination

7/8/77 (Item 59 from file: 31)

World Surface Coatings Abs

(c) 2009 PRA Coat. Tech. Cen. All rights reserved.

## Appendix A-5. Irrelevant Titles

00588879 **WSCA Abstract Number:** 06-04057 **WSCA ID Number:** 624057

**Stabilised dispersions of titanium dioxide nanoparticles via a sol/gel process and applications in ultraviolet-curable hybrid systems.**

**2006**

**Descriptors:** Titanium Dioxide; Nanoparticles; Ultraviolet-curable Coatings; Sols

**Chemical Names:** butyl titanate; titanium dioxide; tetrabutyl titanate; hydrochloric acid ; Silane; 3-trimethoxysilylpropyl methacrylate; Ethyl acrylate; hexanediol diacrylate

**Identifiers:** Titanium Dioxide-- nanoparticles, dispersions/ultraviolet-curables;

Nanoparticles-- titanium dioxide, dispersions/ultraviolet-curables; Ultraviolet-curable Coatings-- titanium dioxide, nanoparticles; Sols-- sols/gels processes, titanium dioxide nanoparticles by

**Additional Terms (Identifiers):** UV-curable coating; ultraviolet-curable coating

7/8/78 (Item 60 from file: 31)

World Surface Coatings Abs

(c) 2009 PRA Coat. Tech. Cen. All rights reserved.

00588349 **WSCA Abstract Number:** 06-03527 **WSCA ID Number:** 623527

**Visible light-sensitised production of hydrogen using perfluorosulphonate polymer-coated titanium dioxide nanoparticles: an alternative approach to sensitiser anchoring.**

**2006**

**Descriptors:**

Titanium Dioxide; Hydrogen; Photoactivity; Polymers, Sulphonated

**Company Names:** Degussa; Aberchromics; Dupont

**Brand/Product Names:** P-25; Aberchrome 540; Nafion

**Chemical Names:** ethylenediaminetetraacetic acid; platinum; fluoro; dipyrityl; sulphonic acid; titanium dioxide; hydrogen; anatase; chloroplatinic acid; ruthenium(II)

**Identifiers:** Titanium Dioxide-- modified, hydrogen generation/light (visible); Hydrogen -- generation, titanium dioxide (modified)/light (visible); Photoactivity -- titanium dioxide (modified), hydrogen generation; Polymers, Sulphonated -- titanium dioxide modified by

**Additional Terms (Identifiers):** photocatalyst; photocatalytic activity; photoactivity; zeta potential; adsorption

7/8/79 (Item 61 from file: 31)

World Surface Coatings Abs

(c) 2009 PRA Coat. Tech. Cen. All rights reserved.

00584076 **WSCA Abstract Number:** 05-07655 **WSCA ID Number:** 607655

**Fabrication and photocatalytic characterisations of ordered nano -porous X-doped (X being nitrogen, carbon, sulphur, ruthenium, tellurium or silicon) titanium dioxide/aluminium oxide films on indium tin oxide (ITO)/glass.**

**2005**

**Descriptors:** Photoactivity; Titanium Dioxide; Acetaldehyde; Dioxins

**Chemical Names:** dioxin; chloro; titanium dioxide; aluminium oxide; acetaldehyde; oxide ; nitrogen; carbon; sulphur; silicon; ruthenium; tellurium; heptachlorodibenzodioxin

**Identifiers:** Photoactivity-- titanium dioxide/aluminium oxide, & doping effects; Titanium Dioxide-- aluminium oxide &, photoactivity, & doping effects; Acetaldehyde--

## Appendix A-5. Irrelevant Titles

photodegradation, titanium dioxide/aluminium oxide ; Dioxins-- photodegradation, titanium dioxide/aluminium oxide

**Additional Terms (Identifiers):** glass substrate; catalyst; UV; pollutant; scanning electron microscopy; SEM; electron microscopy; EM; photocatalyst; photodegradation; photoactivity

7/8/80 (Item 62 from file: 31)

World Surface Coatings Abs

(c) 2009 PRA Coat. Tech. Cen. All rights reserved.

00583136 **WSCA Abstract Number:** 05-06715 **WSCA ID Number:** 606715

**High-density arrays of titanium dioxide nanoparticles using monolayer micellar films of diblock copolymers as templates.**

**2005**

**Descriptors:** Titanium Dioxide; Block Copolymers; Nanoparticles; Luminescence; Vinylpyridines

**Chemical Names:** titanium dioxide; styrene; 2-vinylpyridine; titanium tetrachloride; oxygen

**Identifiers:** Titanium Dioxide-- nanoparticles, arrays from block copolymers micelles monolayers; Block Copolymers-- micelles, monolayers, oxides nanoparticles arrays by; Nanoparticles-- titanium dioxide, arrays from block copolymers micelles monolayers; Luminescence-- titanium dioxide nanoparticles arrays; Vinylpyridines-- block copolymers, titanium dioxide formation in domains

**Additional Terms (Identifiers):** particle size; UV radiation; ultraviolet radiation

7/8/81 (Item 63 from file: 31)

World Surface Coatings Abs

(c) 2009 PRA Coat. Tech. Cen. All rights reserved.

00582612 **WSCA Abstract Number:** 05-06191 **WSCA ID Number:** 606191

**Photocatalytic polypyrrole/titanium dioxide nanoparticles composite thin film generated at the air/water interface.**

**2005**

**Descriptors:** Photoactivity; Titanium Dioxide; Pyrroles; Nanoparticles; Dyes; Photodegradation; Titanium Dioxide

**Chemical Names:** tetraisopropyl titanate; isopropyl titanate; titanium dioxide; hydrogen peroxide; peroxy; pyrrole; polypyrrole; oxide; methylene blue; methyl orange; iodide

**Identifiers:** Photoactivity-- titanium dioxide/pyrroles polymers, films, generation & ; Titanium Dioxide-- nanoparticles, pyrroles polymerisation presence, films by; Pyrroles-- polymerisation, presence titanium dioxide/hydrogen peroxide products; Nanoparticles-- titanium dioxide, pyrroles polymerisation presence, films by; Dyes-- photodegradation, titanium dioxide/hydrogen peroxide; Photodegradation-- dyes, titanium dioxide/hydrogen peroxide; Titanium Dioxide-- modified, by hydrogen peroxide

**Additional Terms (Identifiers):** anatase; X-ray diffraction; conductive polymer; photoactivity; dye; photodegradation

## Appendix A-5. Irrelevant Titles

7/8/82 (Item 64 from file: 31)

World Surface Coatings Abs

(c) 2009 PRA Coat. Tech. Cen. All rights reserved.

00582533 **WSCA Abstract Number:** 05-06112 **WSCA ID Number:** 606112

**Nanometre titanium dioxide.**

**2005**

**Descriptors:** Titanium Dioxide; Nanoparticles; Antimicrobial Activity; Titanium Dioxide; Anhui Kena New Materials Co

**Company Names:** Anhui Kena New Materials Co; Huaibei Luling Coal Mine; Tengling Industry & Trade Co

**Geographic Names:** China; Suzhou; Anhui

**Chemical Names:** titanium dioxide

**Identifiers:** Titanium Dioxide-- nanoparticles, grades (Chinese); Nanoparticles-- titanium dioxide, grades (Chinese); Antimicrobial Activity-- titanium dioxide, companies (Chinese); Titanium Dioxide-- antimicrobial activity, companies (Chinese); Anhui Kena New Materials Co-- titanium dioxide, nanoparticles grades/antimicrobial activity

**Additional Terms (Identifiers):** BUSN; joint venture; investment; Chinese chemicals manufacturer; nanoparticle; antimicrobial activity

7/8/83 (Item 65 from file: 31)

World Surface Coatings Abs

(c) 2009 PRA Coat. Tech. Cen. All rights reserved.

00581895 **WSCA Abstract Number:** 05-05474 **WSCA ID Number:** 605474

**Preparation and photoactivity of nanostructured titanium dioxide particles obtained by hydrolysis of titanium(IV) chloride.**

**2005**

**Descriptors:** Titanium Dioxide; Photoactivity

**Company Names:** Degussa

**Brand/Product Names:** P-25

**Chemical Names:** titanium dioxide; chloride; 4-Nitrophenol; chloride

**Identifiers:** Titanium Dioxide-- manufacture/photoactivity; Photoactivity-- titanium dioxide, from titanium chloride

**Additional Terms (Identifiers):** SEM; proprietary

7/8/84 (Item 66 from file: 31)

World Surface Coatings Abs

(c) 2009 PRA Coat. Tech. Cen. All rights reserved.

00577125 **WSCA Abstract Number:** 05-00704 **WSCA ID Number:** 600704

**Aqueous sol/gel route to synthesise nano-sized lanthana-doped titanium dioxide have an increased anatase phase stability for photocatalytic application.**

**2005**

**Descriptors:** Titanium Dioxide; Lanthanum Oxide; Photoactivity; Titanium Dioxide; Sols; Nanoparticles

**Chemical Names:** lanthanum oxide; titanium dioxide; titanyl sulphate; anatase; methylene

## Appendix A-5. Irrelevant Titles

blue

**Identifiers:** Titanium Dioxide-- colloidal, doped by lanthanum oxide; Lanthanum Oxide-- titanium dioxide doped by; Photoactivity-- titanium dioxide (doped), by lanthanum oxide; Titanium Dioxide-- doped, photoactivity; Sols-- sols/gels processes, titanium dioxide (doped) by; Nanoparticles-- titanium dioxide (doped)

**Additional Terms (Identifiers):** UV radiation; ultraviolet radiation; photodegradation

7/8/85 (Item 67 from file: 31)

World Surface Coatings Abs

(c) 2009 PRA Coat. Tech. Cen. All rights reserved.

00576938 **WSCA Abstract Number:** 05-00517 **WSCA ID Number:** 600517

**Modelling of nanostructured titanium dioxide spheres obtained by ultrasonic spray pyrolysis.**

**2004**

**Descriptors:** Titanium Dioxide; Nanoparticles; Nanoparticles

**Identifiers:** Titanium Dioxide-- nanoparticles, spheres/spheres (hollow), modelling; Nanoparticles-- titanium dioxide, spheres/spheres (hollow), modelling; Nanoparticles-- titanium dioxide, spheres/spheres (hollow), dimensions

**Additional Terms (Identifiers):** particle size distribution; ultrasonics

7/8/86 (Item 68 from file: 31)

World Surface Coatings Abs

(c) 2009 PRA Coat. Tech. Cen. All rights reserved.

00575748 **WSCA Abstract Number:** 04-07903 **WSCA ID Number:** 587903

**Metachromatic effects and photodegradation of Basic Blue on nanocrystalline titanium dioxide films.**

**2004**

**Descriptors:** Humidity; Dyes; Colour Changes; Photodegradation; Dyes

**Company Names:** Dow Chemical

**Brand/Product Names:** Triton X-100

**Chemical Names:** azo; methyl silicate; benzothiazole; benzothiazolium; zinc; titanium dioxide; silica; oxide; tetraisopropyl titanate; tetramethyl silicate

**Identifiers:** Humidity-- sensors, dyes on oxides, metachromaticity; Dyes-- on oxides, metachromaticity; Colour Changes-- dyes, on oxides, metachromaticity/humidity;

Photodegradation-- dyes, on oxides, humidity &; Dyes-- photodegradation, on oxides

**Additional Terms (Identifiers):** optical properties; contact angle; metachromasy; sol/gel process; photoactivity

7/8/87 (Item 69 from file: 31)

World Surface Coatings Abs

(c) 2009 PRA Coat. Tech. Cen. All rights reserved.

00575736 **WSCA Abstract Number:** 04-07891 **WSCA ID Number:** 587891

**Designing of nanostructured hollow titanium dioxide spheres obtained by ultrasonic spray pyrolysis.**

## Appendix A-5. Irrelevant Titles

**2004**

**Descriptors:** Titanium Dioxide; Nanoparticles

**Chemical Names:** titanium dioxide

**Identifiers:** Titanium Dioxide-- spheres (hollow), from nanoparticles/spray pyrolysis; Nanoparticles-- titanium dioxide, precursors for spheres (hollow)

**Additional Terms (Identifiers):** hollow sphere; particle size distribution; ultrasonics

7/8/88 (Item 70 from file: 31)

World Surface Coatings Abs

(c) 2009 PRA Coat. Tech. Cen. All rights reserved.

00574837 **WSCA Abstract Number:** 04-06992 **WSCA ID Number:** 586992

**Influence of zinc dopant on the structural transformation of gel-derived nano-sized titanium dioxide powders.**

**2003**

**Descriptors:** Titanium Dioxide; Zinc Compounds; Phase Behaviour; Ultraviolet Radiation

**Chemical Names:** zinc titanate; metatitanate; Titanium dioxide; tetrabutyl titanate; zinc nitrate; zinc; rutile; zinc metatitanate; rutile; anatase

**Identifiers:** Titanium Dioxide-- doped, zinc, effects/phase transformation; Zinc Compounds-- titanium dioxide (doped); Phase Behaviour-- transformation, titanium dioxide, zinc compounds effects; Ultraviolet Radiation-- absorption, titanium dioxide (doped)

**Additional Terms (Identifiers):** ultrasonics; UV absorption; ultraviolet absorption; crystallinity; Brunauer-Emmett-Teller; BET; morphology; phase transformation

7/8/90 (Item 72 from file: 31)

World Surface Coatings Abs

(c) 2009 PRA Coat. Tech. Cen. All rights reserved.

00570555 **WSCA Abstract Number:** 04-02710 **WSCA ID Number:** 582710

**Photocatalytic degradation of organic compounds over combustion-synthesised nano-titanium dioxide.**

**2004**

**Descriptors:** Titanium Dioxide; Nanoparticles; Photoactivity; Phenols; Salicylic Acid

**Company Names:** Degussa

**Brand/Product Names:** P-25

**Chemical Names:** phenol; p-nitrophenol; salicylic acid; catechol; hydroquinone; hydroxyl

**Identifiers:** Titanium Dioxide-- nanoparticles, photoactivity, organics degradation; Nanoparticles-- titanium dioxide, photoactivity, organics degradation; Photoactivity-- titanium dioxide, nanoparticles, organics degradation; Phenols-- photodegradation, titanium dioxide nanoparticles; Salicylic Acid -- photodegradation, titanium dioxide nanoparticles

**Additional Terms (Identifiers):** HPL; photoactivity; photodegradation; UV radiation; ultraviolet radiation; sunlight; nanoparticle

7/8/91 (Item 73 from file: 31)

World Surface Coatings Abs

(c) 2009 PRA Coat. Tech. Cen. All rights reserved.

## Appendix A-5. Irrelevant Titles

00569162 **WSCA Abstract Number:** 04-01317 **WSCA ID Number:** 581317

**Photocatalytic water treatment with different titanium dioxide nanoparticles and hydrophilic/hydrophobic layer silicate adsorbents.**

**2003**

**Descriptors:** Chlorophenols; Photodegradation; Titanium Dioxide; Montmorillonite; Water

**Company Names:** Degussa

**Brand/Product Names:** P25

**Chemical Names:** pyridinium; clay; titanium dioxide; silicate; montmorillonite; hexadecylpyridinium chloride

**Identifiers:** Chlorophenols-- photodegradation, titanium dioxide/montmorillonite; Photodegradation-- chlorophenols, titanium dioxide/montmorillonite; Titanium Dioxide-- photoactivity, montmorillonite &, chlorophenols; Montmorillonite-- titanium dioxide &, photoactivity, chlorophenols; Water-- treatment, chlorophenols photodegradation

**Additional Terms (Identifiers):** HPL; photoactivity; photocatalyst; intercalation compound

7/8/92 (Item 74 from file: 31)

World Surface Coatings Abs

(c) 2009 PRA Coat. Tech. Cen. All rights reserved.

00567861 **WSCA Abstract Number:** 04-00016 **WSCA ID Number:** 580016

**Nanocrystalline titanium dioxide thin films on soda-lime/silica glass by using a titanium naphthenate precursor.**

**2003**

**Descriptors:** Titanium Dioxide; Titanium Naphthenate

**Chemical Names:** titanium naphthenate; anatase; titanium dioxide

**Identifiers:** Titanium Dioxide-- thin films, from naphthenates/healing; Titanium Naphthenate-- application, titanium dioxide, thin films from

**Additional Terms (Identifiers):** APP; glass substrate; AFM; atomic force microscopy; transparency; spectroscopy

7/8/93 (Item 75 from file: 31)

World Surface Coatings Abs

(c) 2009 PRA Coat. Tech. Cen. All rights reserved.

00567855 **WSCA Abstract Number:** 04-00010 **WSCA ID Number:** 580010

**Photocatalytic properties of nanostructured titanium dioxide plasma sprayed coating.**

**2003**

**Descriptors:** Titanium Dioxide; Photoactivity; Plasma; Dyes; Nanoparticles

**Chemical Names:** titanium; anatase; methylene blue

**Identifiers:** Titanium Dioxide-- nanoparticles, plasma spraying/coatings, photoactivity; Photoactivity-- titanium dioxide, coatings by plasma spraying; Plasma-- spraying, titanium dioxide coatings by; Dyes-- photodegradation, titanium dioxide coatings by; Nanoparticles-- titanium dioxide, plasma spraying/coatings photoactivity

**Additional Terms (Identifiers):** APP; stainless steel substrate; photoactivity; dye; nanoparticle; photocatalyst

## Appendix A-5. Irrelevant Titles

7/8/94 (Item 76 from file: 31)

World Surface Coatings Abs

(c) 2009 PRA Coat. Tech. Cen. All rights reserved.

00566974 **WSCA Abstract Number:** 03-08141 **WSCA ID Number:** 568141

**Tibet develops nanometre titanium dioxide.**

**2003**

**Descriptors:** Titanium Dioxide; Nanoparticles; Tibet Lhasa Green Energy Science & Technology Biochemical Institute

**Company Names:** Tibet Lhasa Green Energy Science & Technology Biochemical Institute

**Geographic Names:** Tibet

**Chemical Names:** titanium dioxide

**Identifiers:** Titanium Dioxide-- nanoparticles, developments (Tibetan); Nanoparticles-- titanium dioxide, developments (Tibetan); Tibet Lhasa Green Energy Science & Technology Biochemical Institute-- titanium dioxide

**Additional Terms (Identifiers):** BUSN; investment; nanoparticle

7/8/95 (Item 77 from file: 31)

World Surface Coatings Abs

(c) 2009 PRA Coat. Tech. Cen. All rights reserved.

00566423 **WSCA Abstract Number:** 03-07590 **WSCA ID Number:** 567590

**Synthesis of uniform anatase titanium dioxide nanoparticles by gel/sol method. III.**

**Formation process and size control.**

**2003**

**Descriptors:** Titanium Dioxide; Nanoparticles; Sols; Particle Size

**Chemical Names:** titanium hydroxide; anatase; titanium dioxide; titanitic acid; triethanolamine; hydroxide; amine

**Identifiers:** Titanium Dioxide-- anatase, nanoparticles, from titanitic, size/shape; Nanoparticles-- titanium dioxide (anatase), from titanitic, size/shape; Sols -- sols/gels processes, titanium dioxide from titanitic; Particle Size-- titanium dioxide, nanoparticles, size control

**Additional Terms (Identifiers):** sol/gel process; hydrogen ion concentration; particle size

7/8/97 (Item 79 from file: 31)

World Surface Coatings Abs

(c) 2009 PRA Coat. Tech. Cen. All rights reserved.

00565665 **WSCA Abstract Number:** 03-06832 **WSCA ID Number:** 566832

**Optimal conditions for synthesis of titanium dioxide nanoparticles in semi-batch reactor.**

**2003**

**Descriptors:** Titanium Dioxide; Nanoparticles

**Chemical Names:** ethyl titanate; cellulose ether; tetraethyl titanate; titanium dioxide; hydroxypropylcellulose

**Identifiers:** Titanium Dioxide-- nanoparticles, synthesis optimum conditions; Nanoparticles-

## Appendix A-5. Irrelevant Titles

- titanium dioxide, synthesis optimum conditions

7/8/98 (Item 80 from file: 31)

World Surface Coatings Abs

(c) 2009 PRA Coat. Tech. Cen. All rights reserved.

00565436 **WSCA Abstract Number:** 03-06603 **WSCA ID Number:** 566603

**Dispersion properties of titanium dioxide nano-powder synthesised by homogeneous precipitation process at low temperatures.**

**2003**

**Descriptors:** Titanium Dioxide; Nanoparticles; Dispersions

**Company Names:** Degussa; Tayca

**Brand/Product Names:** P-25; MT-500 HD

**Chemical Names:** rutile; titanium dioxide; caesium chloride; calcium chloride; ferric chloride; zirconium tetrachloride

**Identifiers:** Titanium Dioxide-- nanoparticles, dispersions, stability, aq/solvents/electrolytes; Nanoparticles-- titanium dioxide, dispersions, stability, aq/solvents/electrolytes; Dispersions-- titanium dioxide, nanoparticles, stability, aq/solvents/electrolytes

**Additional Terms (Identifiers):** viscosity; hydrogen ion concentration; valency; nanoparticle; aqueous dispersion

7/8/99 (Item 81 from file: 31)

World Surface Coatings Abs

(c) 2009 PRA Coat. Tech. Cen. All rights reserved.

00562596 **WSCA Abstract Number:** 03-03763 **WSCA ID Number:** 563763

**Preparation of nanoporous titanium dioxide films by surface sol/gel process accompanied by low temperature oxygen plasma treatment.**

**2002**

**Descriptors:** Titanium Dioxide; Pores; Sols; Titanates

**Chemical Names:** butyl titanate; titanate; titanium dioxide; tetrabutyl titanate; polyacrylic acid; oxygen; oxide; silver

**Identifiers:** Titanium Dioxide-- thin films, by sols/gels, pores; Pores-- nano-, titanium dioxide thin films; Sols-- sols/gels processes, titanates/polyacrylic acid, organics removal; Titanates-- sols/gels processes

**Additional Terms (Identifiers):** EM; pores; scanning electron microscopy; SEM; ESCA; electron spectroscopy for chemical analysis; gold substrate; quartz substrate; mica substrate

7/8/100 (Item 82 from file: 31)

World Surface Coatings Abs

(c) 2009 PRA Coat. Tech. Cen. All rights reserved.

00561974 **WSCA Abstract Number:** 03-03141 **WSCA ID Number:** 563141

**Synthesis and morphology characterisation study of bis(aminophenyl)oxadiazole/oxydiphthalic anhydride polyimide/ titanium dioxide nano-hybrid films.**

**2003**

## Appendix A-5. Irrelevant Titles

**Descriptors:** Polyimides; Titanium Dioxide; Nanoparticles; Sols

**Chemical Names:** diphenyl ether tetracarboxylic dianhydride; titanate; ethyl titanate; oxadiazole; Polyamic acid; tetraethyl titanate

**Identifiers:** Polyimides-- films, titanium dioxide nanoparticles &, formation; Titanium Dioxide-- nanoparticles, films, polyimides &, formation; Nanoparticles-- titanium dioxide, films, polyimides &, formation; Sols -- sols/gels processes, polyimides/titanium dioxide nanoparticles

**Additional Terms (Identifiers):** ESCA; electron spectroscopy for chemical analysis; transmission EM; FTIR ; Fourier transform infrared spectroscopy

7/8/101 (Item 83 from file: 31)

World Surface Coatings Abs

(c) 2009 PRA Coat. Tech. Cen. All rights reserved.

00560826 **WSCA Abstract Number:** 03-01993 **WSCA ID Number:** 561993

**Chemiluminescence determination of chlorinated volatile organic compounds by conversion on nanometre titanium dioxide.**

**2002**

**Descriptors:** Titanium Dioxide; Nanoparticles; Volatiles, Organic; Chlorinated Compounds

**Chemical Names:**

chloro; methylene chloride; chloroform; chlorine; carbon tetrachloride

**Identifiers:** Titanium Dioxide-- nanoparticles, chlorinated compounds decomposition; Nanoparticles-- titanium dioxide, chlorinated compounds decomposition; Volatiles, Organic-- chlorinated compounds, determination; Chlorinated Compounds-- volatiles (org), determination

**Additional Terms (Identifiers):** HPL; nanoparticle; transmission EM; ESCA; electron spectroscopy for chemical analysis; chlorinated VOC

7/8/102 (Item 84 from file: 31)

World Surface Coatings Abs

(c) 2009 PRA Coat. Tech. Cen. All rights reserved.

00559589 **WSCA Abstract Number:** 03-00756 **WSCA ID Number:** 560756

**Preparation and characterisation of nano-titanium dioxide powder.**

**2002**

**Descriptors:** Titanium Dioxide; Nanoparticles; X-Ray Diffraction; Sols

**Chemical Names:** butyl titanate; titanate; titanium dioxide

**Identifiers:** Titanium Dioxide-- nanoparticles, manufacture, particle size/morphology; Nanoparticles-- titanium dioxide, manufacture, particle size/morphology; X-Ray Diffraction-- titanium dioxide, nanoparticles; Sols-- sols/gels processes, titanium dioxide nanoparticles manufacture

**Additional Terms (Identifiers):** morphology; hydrogen ion concentration; microparticle; nanoparticle; sol/gel process

7/8/103 (Item 85 from file: 31)

## Appendix A-5. Irrelevant Titles

World Surface Coatings Abs

(c) 2009 PRA Coat. Tech. Cen. All rights reserved.

00559402 **WSCA Abstract Number:** 03-00569 **WSCA ID Number:** 560569

**Synthesis of uniform anatase titanium dioxide nanoparticles by gel/sol method. II. Adsorption of hydroxide ions to orthotitanic acid gel and titanium dioxide particles. 2002**

**Descriptors:** Titanium Dioxide; Adsorption; Titanates; Sols

**Chemical Names:** titanium isopropoxide; tetraisopropyl titanate; titanate; titanic acid; anatase; titanium dioxide; hydroxide; sodium perchlorate; orthotitanic acid

**Identifiers:** Titanium Dioxide-- anatase, manufacture, adsorption/desorption during; Adsorption-- hydroxides/protons, during titanium dioxide manufacture; Titanates-- products, titanium dioxide manufacture adsorption during; Sols -- sols/gels processes, titanium dioxide manufacture

**Additional Terms (Identifiers):** hydrogen ion concentration; sol/gel process

7/8/104 (Item 86 from file: 31)

World Surface Coatings Abs

(c) 2009 PRA Coat. Tech. Cen. All rights reserved.

00558838 **WSCA Abstract Number:** 03-00005 **WSCA ID Number:** 560005

**Process-dependent photocatalytic properties of polymer thin films containing titanium dioxide nanoparticles: dip versus spin self-assembly methods. 2002**

**Descriptors:** Titanium Dioxide; Photoactivity; Microparticles

**Chemical Names:** iodine; allylamine; amine; anatase; titanium dioxide; allylamine; hydrochloride; acrylic acid; methyl orange; iodide; polyacrylic acid

**Identifiers:** Titanium Dioxide-- nanoparticles, layers, polymers layers &, & photoactivity; Photoactivity-- titanium dioxide, nanoparticles layers, polymers layers &; Microparticles-- nanoparticles, titanium dioxide, layers

**Additional Terms (Identifiers):** photodegradation; electron microscopy; EM; stratified coating; photocatalyst; photoactivity; glass substrate; plastics substrate; polystyrene substrate; silicon substrate; microparticle

7/8/105 (Item 87 from file: 31)

World Surface Coatings Abs

(c) 2009 PRA Coat. Tech. Cen. All rights reserved.

00555359 **WSCA Abstract Number:** 02-05206 **WSCA ID Number:** 545206

**Titanium dioxide nanoparticle coatings for self-cleaning and anti-microbial application. 2002**

**Descriptors:** Titanium Dioxide; Photoactivity; Self-cleaning Coatings; Anti-misting Coatings; Antimicrobial Activity; Silanes; Plastics; Microparticles

**Chemical Names:** protein; silane; titanium dioxide; anatase; alkoxy silane; albumin

**Identifiers:** Titanium Dioxide-- modified, by silanes, nanoparticles, photoactivity etc; Photoactivity-- titanium dioxide (modified), coatings, proteins &; Self-cleaning Coatings-- titanium dioxide (modified), by silanes; Anti-misting Coatings-- titanium dioxide (modified), by silanes; Antimicrobial Activity-- titanium dioxide (modified), by silanes; Silanes --

## Appendix A-5. Irrelevant Titles

titanium dioxide modified by, coatings/activity; Plastics-- coatings, photoactivity etc;  
Microparticles-- nanoparticles, titanium dioxide (modified)

**Additional Terms (Identifiers):** anti-misting coating; plastics substrate; primer

7/8/106 (Item 88 from file: 31)

World Surface Coatings Abs

(c) 2009 PRA Coat. Tech. Cen. All rights reserved.

00553951 **WCSA Abstract Number:** 02-03798 **WCSA ID Number:** 543798

**Low temperature synthesis of nanosize rutile titanium dioxide crystal in liquid media. 2002**

**Descriptors:** Titanium Dioxide; Microparticles; Photoactivity; Phenol

**Company Names:** Degussa

**Brand/Product Names:** P-25

**Chemical Names:** tetraisopropyl titanate; hydrochloric acid; nitric acid; phenol

**Identifiers:** Titanium Dioxide-- nanoparticles, from titanates, hydrolysis/dissolution/reprecipitation; Microparticles-- nanoparticles, titanium dioxide; Photoactivity-- titanium dioxide, nanoparticles/phenol degradation; Phenol-- photodegradation, titanium dioxide photoactivity

**Additional Terms (Identifiers):** HPL; nanoparticle; hydrogen ion concentration; photocatalyst; photoactivity; Raman spectroscopy; hydrogen ion concentration; photodegradation

7/8/107 (Item 1 from file: 32)

METADEX

(c) 2009 CSA. All rights reserved.

0004876412 IP Accession No: 200911-71-1328834

**Synthesis and characterization of colloidal titania nanoparticles**

**Publication Date:** 2008

**Descriptors:** Titanium dioxide; Ethyl alcohol; Annealing; Titanium; Sol gel **process**; Ethanol; Diffraction; Catalysts; Deposition; Acetonitrile; Catalysis; Synthesis; Crystal structure; X-rays; Wafers; Alkoxides; Scanning electron microscopy; Colloids; Hydrolysis; Condensing; Nanoparticles; Monolayers; Silicon

**Subj Catg:** 71, General and Nonclassified

7/8/108 (Item 2 from file: 32)

METADEX

(c) 2009 CSA. All rights reserved.

0004875685 IP Accession No: 200911-23-1332486

**Study on simultaneous determination of zinc and copper by flame atomic absorption spectrometry after pre-enrichment with nanometer titanium dioxide**

**Publication Date:** 2009

**Descriptors:** Titanium dioxide; Atomic absorption **analysis**; Zinc; Linearity; Hydrochloric

## Appendix A-5. Irrelevant Titles

acid; Titanium oxides; Metallurgical **analysis**; Copper; Metal ions; Recovery  
**Subj Catg:** 23, Analysis

7/8/109 (Item 3 from file: 32)

METADEX

(c) 2009 CSA. All rights reserved.

0004873876 IP Accession No: 200911-71-1328988

**Shape deformation of colloidal titania nanoparticles by means of ion irradiation**

**Publication Date: 2008**

**Descriptors:** Titanium dioxide; Silicon; Ethyl alcohol; Ion beams; Ion irradiation; Irradiation; Deformation; Electronics; Annealing; Titanium; Sol gel **process**; Ethanol; Catalysts; Silicon substrates; Deposition; Acetonitrile; Fluence; Silicon dioxide; Scanning electron microscopy; Colloids; Hydrolysis; Condensing; Nanoparticles; Monolayers; Ammonia

**Subj Catg:** 71, General and Nonclassified

7/8/110 (Item 4 from file: 32)

METADEX

(c) 2009 CSA. All rights reserved.

0004868260 IP Accession No: 200911-71-1328293

**Anti-microbial activity of doped anatase titania coated nickel ferrite composite nanoparticles**

**Publication Date: 2007**

**Descriptors:** Titanium dioxide; Nanoparticles; Nickel ferrites; Anatase; Heat treatment; Materials science; Shells; Magnetic cores

**Subj Catg:** 71, General and Nonclassified

7/8/111 (Item 5 from file: 32)

METADEX

(c) 2009 CSA. All rights reserved.

0004851317 IP Accession No: 200910-34-1291525

**W-doped titania nanoparticles for UV and visible-light photocatalytic reactions**

**Publication Date: 2009**

**Descriptors:** Tungsten; Degradation; titanium dioxide; Chlorides; Catalysis; Hydrolysis; Absorption; Titanium dioxide; Photocatalysis; Tungsten; Sol gel **process**; Photocatalysts; Precursors; **Aqueous** solutions; Chlorides

**Subj Catg:** 34, Chemical and Electrochemical Properties

7/8/113 (Item 7 from file: 32)

METADEX

(c) 2009 CSA. All rights reserved.

0004848528 IP Accession No: 200910-71-1292360

## Appendix A-5. Irrelevant Titles

**Synthesis, structure and properties of a novel hybrid bimodal network elastomer with inorganic cross-links: The case of silicone- nanocrystalline titania**

**Publication Date: 2009**

**Descriptors:** Titanium dioxide; Elastomers; Crosslinking; Networks; Nanostructure; Nanocrystals; Nanomaterials; Reinforcement

**Subj Catg:** 71, General and Nonclassified

7/8/114 (Item 8 from file: 32)

METADEX

(c) 2009 CSA. All rights reserved.

0004843283 IP Accession No: 200910-71-1297018

**Preparation and photocatalytic properties of mixed-phase titania nanospheres by laser ablation**

**Publication Date: 2009**

**Descriptors:** Titanium dioxide; Scanning electron microscopy; Nanospheres; Laser ablation ; Anatase; Rutile; Phase transformations; Photocatalysis

**Subj Catg:** 71, General and Nonclassified

7/8/115 (Item 9 from file: 32)

METADEX

(c) 2009 CSA. All rights reserved.

0004843282 IP Accession No: 200910-71-1296517

**Preparation and photocatalytic performance of nano titania -coated beads**

**Publication Date: 2009**

**Descriptors:** Titanium dioxide; Beads; Photocatalysis; Nanostructure; Chemical vapor deposition; Decomposition reactions; Morphology; Images; Coating; Methylene blue; Nanomaterials; Glass; Catalysts; **Aqueous environments**; Iron; Fluidized beds; Catalysis; Aluminum oxide; Reaction kinetics; Nanocomposites

**Subj Catg:** 71, General and Nonclassified

7/8/116 (Item 10 from file: 32)

METADEX

(c) 2009 CSA. All rights reserved.

0004843265 IP Accession No: 200910-71-1296056

**Preparation and electrochemical capacitance of ruthenium oxide- titania nanotube composite**

**Publication Date: 2009**

**Descriptors:** Nanostructure; Titanium dioxide; Titanium; Nanomaterials; Nanocomposites; Ruthenium oxide; Arrays; Capacitance; Ruthenium; Anodizing; Electrodes; Energy density; Sulfates; Aqueous electrolytes; Glycols; Deposition; Polytechnics; Capacitors; Electrolytes; Utilization; Supercapacitors

**Subj Catg:** 71, General and Nonclassified

## Appendix A-5. Irrelevant Titles

7/8/117 (Item 11 from file: 32)

METADEX

(c) 2009 CSA. All rights reserved.

0004843180 IP Accession No: 200910-71-1298092

**Preparation of platinum-iridium nanoparticles on titania nanotubes by MOCVD and their catalytic evaluation**

**Publication Date: 2009**

**Descriptors:** Titanium dioxide; Nanotubes; Platinum; Catalysts; Catalysis; Nanoparticles; Nanostructure; Hydrogenation

**Subj Catg:** 71, General and Nonclassified

7/8/118 (Item 12 from file: 32)

METADEX

(c) 2009 CSA. All rights reserved.

0004836959 IP Accession No: 200910-54-1290161

**Morphological and structural features of individual and composite nanooxides with alumina, silica, and titania in powders and aqueous suspensions**

**Publication Date: 2009**

**Descriptors:** Nanostructure; Titanium dioxide; Nanocomposites; Aluminum oxide; Nanomaterials; Oxides; Silicon dioxide; Nanoparticles

**Subj Catg:** 54, Powder Technology

7/8/119 (Item 13 from file: 32)

METADEX

(c) 2009 CSA. All rights reserved.

0004828443 IP Accession No: 200910-34-1290823

**Controlled attachment of gold nanoparticles on ordered titania nanotube arrays**

**Publication Date: 2009**

**Descriptors:** Nanostructure; Titanium dioxide; Gold; Nanoparticles; Nanomaterials; Nanocomposites; Arrays; Deposition

**Subj Catg:** 34, Chemical and Electrochemical Properties

7/8/120 (Item 14 from file: 32)

METADEX

(c) 2009 CSA. All rights reserved.

0004820064 IP Accession No: 200909-34-1260650

**Ethanol vapor processing of titania nanotube array films: enhanced crystallization and photoelectrochemical performance**

**Publication Date: 2009**

**Descriptors:** Titanium dioxide; Nanostructure; Ethyl alcohol; Nanocomposites; Nanomaterials; Arrays; Ethanol; Crystallization; Annealing

## Appendix A-5. Irrelevant Titles

**Subj Catg:** 34, Chemical and Electrochemical Properties

7/8/121 (Item 15 from file: 32)

METADEX

(c) 2009 CSA. All rights reserved.

0004804721 IP Accession No: 200909-34-1266661

**Preparation, characterization and visible-light-driven photocatalytic activity of Fe-doped titania nanorods and first-principles study for electronic structures**

**Publication Date: 2009**

**Descriptors:** Spectroscopy; Absorption; Catalysis; Photooxidation; nanotechnology; Irradiation; X-ray diffraction; acetone; Nanorods; Titanium dioxide; Iron; Photocatalysis; Scanning electron microscopy; X-rays; Nanostructure; Titanates

**Subj Catg:** 34, Chemical and Electrochemical Properties

7/8/123 (Item 17 from file: 32)

METADEX

(c) 2009 CSA. All rights reserved.

0004800771 IP Accession No: 200909-34-1260202

**Photocatalytic performance of alumina-incorporated titania composite nanoparticles: Surface area and crystallinity**

**Publication Date: 2009**

**Descriptors:** Titanium dioxide; Aluminum; Titanium; Photocatalysis; Crystallinity; Nanoparticles; Nanostructure; Surface area; Degradation

**Subj Catg:** 34, Chemical and Electrochemical Properties

7/8/124 (Item 18 from file: 32)

METADEX

(c) 2009 CSA. All rights reserved.

0004774155 IP Accession No: 200909-71-1272481

**Effect of organic modification temperature on the microstructure of nanoscale titania**

**Publication Date: 2009**

**Descriptors:** Titanium dioxide; Nanostructure; Nanomaterials; Nanocomposites; Stearic acid; X-ray photoelectron spectroscopy; Crystallites; Spectrometers; Dispersions; Derivatives; Dissolution; Thermogravimetry; Fourier transforms ; Microstructure; Infrared spectra; Distillation; Photoelectrons; X-rays; Monolayers

**Subj Catg:** 71, General and Nonclassified

7/8/125 (Item 19 from file: 32)

METADEX

(c) 2009 CSA. All rights reserved.

0004761259 IP Accession No: 200908-31-1215058

**Wear behaviour of nanostructured alumina-titania coatings deposited by atmospheric**

## Appendix A-5. Irrelevant Titles

### plasma spray

**Publication Date:** 2009

**Descriptors:** Nanostructure; Wear; Cracks; Deflection; Titanium dioxide; Nanomaterials; Coatings

**Subj Catg:** 31, Mechanical Properties

7/8/126 (Item 20 from file: 32)

METADEX

(c) 2009 CSA. All rights reserved.

0004760363 IP Accession No: 200908-32-1212548

**Surface modification of polyethylene (pe) by the deposition of titanium dioxide (TiO@d2) nanoparticles to enhance the photocatalytic activities**

**Publication Date:** 2009

**Descriptors:** Titanium dioxide; Deposition; Surface chemistry; Photocatalysis; Polyethylenes; Atomic force microscopy; X-ray photoelectron spectroscopy

**Subj Catg:** 32, Physical Properties

7/8/127 (Item 21 from file: 32)

METADEX

(c) 2009 CSA. All rights reserved.

0004759719 IP Accession No: 200908-61-1211857

**Preparation and characterization of lanthanum-doped titanium dioxide nanotubes by using anodized aluminum oxide template**

**Publication Date:** 2009

**Descriptors:** Titanium dioxide; Aluminum oxide; Nanotubes; Anodizing; Transmission electron microscopy; Sol gel **process**; Forming; Mechanical engineering; Scanning electron microscopy

**Subj Catg:** 61, Engineering Components and Structures

7/8/128 (Item 22 from file: 32)

METADEX

(c) 2009 CSA. All rights reserved.

0004758668 IP Accession No: 200908-71-1212864

**Morphology-controlled synthesis of chromia-titania nanofibers via electrospinning followed by annealing**

**Publication Date:** 2009

**Descriptors:** Titanium dioxide; Fibers; Chromium; Annealing; Chromium oxides; Electrospinning; Nitrates

**Subj Catg:** 71, General and Nonclassified

7/8/129 (Item 23 from file: 32)

## Appendix A-5. Irrelevant Titles

METADEX

(c) 2009 CSA. All rights reserved.

0004757197 IP Accession No: 200908-34-1212503

**Fabrication of crack-free anodic nanoporous titania and its enhanced photoelectrochemical response**

**Publication Date: 2009**

**Descriptors:** Titanium dioxide; Nanostructure; Nanocomposites; Nanomaterials; Photocatalysis; Waste **water**; Oranges

**Subj Catg:** 34, Chemical and Electrochemical Properties

7/8/130 (Item 24 from file: 32)

METADEX

(c) 2009 CSA. All rights reserved.

0004756156 IP Accession No: 200907-34-1208019

**Visible-induced photocatalytic reactivity of polymer-sensitized titania nanotube films**

**Publication Date: 2009**

**Descriptors:** nanotechnology; Irradiation; sunlight; composite materials; Degradation; Polymers; **Water** treatment; electrolytes; Catalysis; Electrochemistry ; Catalysts; Morphology; Titanium dioxide; Nanostructure; TNT; Nanomaterials; Polythiophene; Nanocomposites; X-ray photoelectron spectroscopy; Sunlight; Anodizing

**Subj Catg:** 34, Chemical and Electrochemical Properties

7/8/131 (Item 25 from file: 32)

METADEX

(c) 2009 CSA. All rights reserved.

0004755828 IP Accession No: 200907-12-1208249

**Through-mask anodization of titania dot- and pillar-like nanostructures on bulk Ti substrates using a nanoporous anodic alumina mask**

**Publication Date: 2009**

**Descriptors:** Nanostructure; Titanium dioxide; Nanomaterials; Nanocomposites; Anodizing; Titanium; Electrolytic cells; In vitro testing; Anodic

**Subj Catg:** 12, Crystal Properties

7/8/132 (Item 26 from file: 32)

METADEX

(c) 2009 CSA. All rights reserved.

0004755075 IP Accession No: 200907-34-1210467

**Self-assembled titania-silica-sepiolite based nanocomposites for water decontamination**

**Publication Date: 2009**

**Descriptors:** Titanium dioxide; Self assembly; Decontamination; Waste water; Nanoparticles; Sepiolite; Fibres

**Subj Catg:** 34, Chemical and Electrochemical Properties

## Appendix A-5. Irrelevant Titles

7/8/133 (Item 27 from file: 32)

METADEX

(c) 2009 CSA. All rights reserved.

0004754717 IP Accession No: 200907-42-1209029

**Optimisation of an annular photoreactor process for degradation of Congo Red using a newly synthesized titania impregnated kaolinite nano-photocatalyst**

**Publication Date: 2009**

**Descriptors:** Titanium dioxide; Photocatalysis; Degradation; Nanostructure; pH; Byproducts; Reactors; Annular; Kaolinite

**Subj Catg:** 42, Extraction and Smelting

7/8/134 (Item 28 from file: 32)

METADEX

(c) 2009 CSA. All rights reserved.

0004754612 IP Accession No: 200907-71-1209090

**Preparation and characterization of nitrogen-doped titania nanotubes**

**Publication Date: 2009**

**Descriptors:** Titanium dioxide; Nanotubes; Annealing; Rutile; Doping; Phase transformations; Anatase; Anodizing; Ammonia

**Subj Catg:** 71, General and Nonclassified

7/8/135 (Item 29 from file: 32)

METADEX

(c) 2009 CSA. All rights reserved.

0004754376 IP Accession No: 200907-34-1208007

**Photo-electro-catalysis enhancement on carbon nanotubes/ titanium dioxide (CNTs/TiO<sub>2</sub>) composite prepared by a novel surfactant wrapping sol-gel method**

**Publication Date: 2008**

**Descriptors:** composite materials; Microscopy; Surfactants; Degradation; Electrodes; Metals; Sodium; X-ray diffraction; nanotechnology; Titanium dioxide; Nanostructure; Mathematical models; Nanomaterials; Nanocomposites; Degradation; Sol gel **process**; Surfactants; Wrapping

**Subj Catg:** 34, Chemical and Electrochemical Properties

7/8/136 (Item 30 from file: 32)

METADEX

(c) 2009 CSA. All rights reserved.

0004754362 IP Accession No: 200907-12-1206992

**Photocatalytic degradation of selected dyes by titania thin films with various nanostructures**

**Publication Date: 2009**

**Descriptors:** Titanium dioxide; Nanostructure; Thin films; Photodegradation; Nanorods; Scanning electron microscopy; Nanomaterials; Nanocomposites; Nanotubes

## Appendix A-5. Irrelevant Titles

**Subj Catg:** 12, Crystal Properties

7/8/137 (Item 31 from file: 32)

METADEX

(c) 2009 CSA. All rights reserved.

0004754053 IP Accession No: 200907-71-1207498

**In-situ growth of titania nanoparticles in electrospun polymer nanofibers at low temperature**

**Publication Date: 2009**

**Descriptors:** Titanium dioxide; Polyethylene terephthalates; Electrospinning; Nanofibers; Nanoparticles; Crystallinity; Ethylene; Titanates; Networks

**Subj Catg:** 71, General and Nonclassified

7/8/138 (Item 32 from file: 32)

METADEX

(c) 2009 CSA. All rights reserved.

0004754020 IP Accession No: 200907-34-1210903

**Nanowire-structured titanate with anatase titania: Characterization and photocatalytic activity**

**Publication Date: 2009**

**Descriptors:** Titanium dioxide; Nanowires; Titanates; Nanostructure; Photocatalysis; Crystallites; Roasting

**Subj Catg:** 34, Chemical and Electrochemical Properties

7/8/139 (Item 33 from file: 32)

METADEX

(c) 2009 CSA. All rights reserved.

0004753779 IP Accession No: 200907-34-1210973

**Influence of water content on nanotubular anodic titania formed in fluoride/glycerol electrolytes**

**Publication Date: 2009**

**Descriptors:** Nanostructure; Titanium dioxide; Nanotubes; Electrolytes; Moisture content; Dissolution; Nanomaterials

**Subj Catg:** 34, Chemical and Electrochemical Properties

7/8/140 (Item 34 from file: 32)

METADEX

(c) 2009 CSA. All rights reserved.

0004753159 IP Accession No: 200907-12-1208044

**Low temperature @iN,N@-dimethylformamide-assisted synthesis and characterization of anatase-rutile biphasic nanostructured titania**

**Publication Date: 2009**

## Appendix A-5. Irrelevant Titles

**Descriptors:** Titanium dioxide; Anatase; Rutile; Nanostructure; Nanorods; X-rays; Specific surface; Spectrometers; Interstitials

**Subj Catg:** 12, Crystal Properties

7/8/141 (Item 35 from file: 32)

METADEX

(c) 2009 CSA. All rights reserved.

0004752625 IP Accession No: 200907-71-1209172

**Formation mechanism of titania nanosheet crytallites on silica-titania gel films by vibration hot-water treatment**

**Publication Date:** 2009

**Descriptors:** Nanostructure; Titanium dioxide; Vibration; Nanomaterials; Nanocomposites; Coatings; Crystallites; Materials science; Dissolution

**Subj Catg:** 71, General and Nonclassified

7/8/142 (Item 36 from file: 32)

METADEX

(c) 2009 CSA. All rights reserved.

0004752218 IP Accession No: 200907-42-1207022

**Fabrication and photo-electrocatalytic properties of highly oriented titania nanotube arrays with {101} crystal face**

**Publication Date:** 2009

**Descriptors:** Titanium dioxide; Nanostructure; Nanocomposites; Nanomaterials; Arrays; Scanning electron microscopy; Crystal structure; Semiconductors; Degradation

**Subj Catg:** 42, Extraction and Smelting

7/8/143 (Item 37 from file: 32)

METADEX

(c) 2009 CSA. All rights reserved.

0004752199 IP Accession No: 200907-61-1207984

**Fabrication of pillar-like titania nanostructures on titanium and their interactions with human skeletal stem cells**

**Publication Date:** 2009

**Descriptors:** Nanostructure; Titanium dioxide; Titanium; Nanomaterials; Nanocomposites; Topography; **Human**; Stem cells; Bones

**Subj Catg:** 61, Engineering Components and Structures

7/8/144 (Item 38 from file: 32)

METADEX

(c) 2009 CSA. All rights reserved.

0004752090 IP Accession No: 200907-42-1209028

**Adsorption and visible-light-derived photocatalytic kinetics of organic dye on Co-doped**

## Appendix A-5. Irrelevant Titles

### **titania nanotubes prepared by hydrothermal synthesis**

**Publication Date: 2009**

**Descriptors:** Photocatalysis; Titanium dioxide; TNT; Surface chemistry; Adsorption; Cobalt; Rate constants; Nanotubes; Dyes

**Subj Catg:** 42, Extraction and Smelting

7/8/145 (Item 39 from file: 32)

METADEX

(c) 2009 CSA. All rights reserved.

0004751762 IP Accession No: 200907-34-1210893

### **Carbon nanotubes/titanium dioxide (CNTs/TiO<sub>2</sub>) nanocomposites prepared by conventional and novel surfactant wrapping sol-gel methods exhibiting enhanced photocatalytic activity**

**Publication Date: 2009**

**Descriptors:** Titanium dioxide; Sol gel **process**; Nanocomposites; Clusters; Surfactants; Wrapping; Photocatalysis

**Subj Catg:** 34, Chemical and Electrochemical Properties

7/8/146 (Item 40 from file: 32)

METADEX

(c) 2009 CSA. All rights reserved.

0004751357 IP Accession No: 200907-61-1209495

### **Bioactive nano-titania ceramics with biomechanical compatibility prepared by doping with piezoelectric BaTiO<sub>3</sub>**

**Publication Date: 2009**

**Descriptors:** Nanostructure; Nanomaterials; Ceramics; Nanocomposites; Inhibitors; Additives; Biocompatibility; Piezoelectricity; Barium titanates

**Subj Catg:** 61, Engineering Components and Structures

7/8/147 (Item 41 from file: 32)

METADEX

(c) 2009 CSA. All rights reserved.

0004739626 IP Accession No: 200906-71-1108867

### **Synthesis and Characterization of Titania Nanoribbons for Lithium Selective Adsorption**

**Publication Date: 2009**

**Descriptors:** Titanium dioxide; Nanostructure; Lithium; Nanomaterials; Selective adsorption; Nanocomposites; Adsorption; Sea **water**; Agglomeration; Extraction; Metal ions; Transmission electron microscopy; Coefficients; Calcines; Oxides; Physical chemistry; Isotherms; Selectivity; Synthesis; Salt **water**; Precursors; Utilization

**Subj Catg:** 71, General and Nonclassified

## Appendix A-5. Irrelevant Titles

7/8/148 (Item 42 from file: 32)

METADEX

(c) 2009 CSA. All rights reserved.

0004683662 IP Accession No: 200906-34-1109801

**Electrochemical synthesis of silica-doped high aspect-ratio titania nanotubes as nanobioceramics for implant applications**

**Publication Date: 2009**

**Descriptors:** Titanium dioxide; Nanotubes; Nanostructure; Anodizing; Electrolytes; Chlorides; Titanium; Nanomaterials; Glass; Deposition; Blood plasma; Ion concentration; Apatite; Synthesis; Implants; **Human**; Silicon dioxide; Nanocomposites

**Subj Catg:** 34, Chemical and Electrochemical Properties

7/8/149 (Item 43 from file: 32)

METADEX

(c) 2009 CSA. All rights reserved.

0004668851 IP Accession No: 200906-71-1206476

**Direct continuous hydrothermal synthesis of high surface area nanosized titania**

**Publication Date: 2009**

**Descriptors:** Nanostructure; Titanium dioxide; Heat treatment; Nanomaterials; Nanocomposites; Anatase; Surface area; Synthesis; Particle size; Rutile; Crystallites; Dioxides; Diffraction; Reactors; Phase composition; Crystallization; Raman spectroscopy; Catalytic activity; Photocatalysis; Crystallinity; X-rays; Methylene blue; C band; Electron microscopy; **Aqueous** solutions; Dyes

**Subj Catg:** 71, General and Nonclassified

7/8/152 (Item 46 from file: 32)

METADEX

(c) 2009 CSA. All rights reserved.

0004598793 IP Accession No: 200905-12-1019740

**Nanostructured Electrode with Titania Nanotube Arrays: Fabrication, Electrochemical Properties, and Applications for Biosensing**

**Publication Date: 2009**

**Descriptors:** Arrays; Titanium dioxide; TNT; Nanostructure; Annealing; Electrochemical impedance spectroscopy; Electrodes; Roasting; Nanomaterials; Resistivity; Electrical resistivity; Electrical conductivity; Scanning electron microscopy; Nanocomposites; Chlorides; Anodizing; Foils; Silver; Capacitance; Reduction; Titanium; Diffraction; Morphology; Drying; Argon; Oxidation; pH; Peroxidase; Calcination; Electrolytes

**Subj Catg:** 12, Crystal Properties

7/8/153 (Item 47 from file: 32)

METADEX

(c) 2009 CSA. All rights reserved.

0004579742 IP Accession No: 200905-71-1021058

## Appendix A-5. Irrelevant Titles

### **Microfabricated structures and devices featuring nanostructured titania thin films.**

**Publication Date: 2007**

**Descriptors:** Titanium dioxide; Nanostructure; Thin films; Titanium; Devices; Format; Wafers; Arrays; Microstructure; Nanocomposites; Nanomaterials; Microfluidics; Photovoltaic cells; Design engineering; Sol gel **process**; Solar cells; Hydrogen peroxide; Bridges (structures); Sensors; Bonding; Patterning; **Detection**; Tides; Etching; **Exposure**; Harvesting; Numerical **analysis**; Wicks; Nanoparticles; Dyes

**Subj Catg:** 71, General and Nonclassified

7/8/154 (Item 48 from file: 32)

METADEX

(c) 2009 CSA. All rights reserved.

0004560395 IP Accession No: 200905-12-1018292

### **Fabrication of titania nanotubular film with metal nanoparticles**

**Publication Date: 2009**

**Descriptors:** Titanium dioxide; Nanostructure; Photocatalysis; Nanocomposites; Nanomaterials; Noble metals; Deposition; Dyes; Annealing; Wetting; Nanoparticles; Synthesis; Catalysis; Decomposition; Catalysts

**Subj Catg:** 12, Crystal Properties

7/8/155 (Item 49 from file: 32)

METADEX

(c) 2009 CSA. All rights reserved.

0004514873 IP Accession No: 200904-12-0951994; 200904-12-0774049

### **Atomic layer deposition of titanium dioxide nanostructures using carbon nanosheets as a template**

**Publication Date: 2009**

**Descriptors:** Nanostructure; Titanium dioxide; Nanocomposites; Nanomaterials; Deposition; Nucleation; Carbon; Pinholes; Anatase; Crystal defects; Crystal structure; Solar cells; Photovoltaic cells; Grains; Photocatalysis

**Subj Catg:** 12, Crystal Properties

7/8/156 (Item 50 from file: 32)

METADEX

(c) 2009 CSA. All rights reserved.

0004508196 IP Accession No: 200904-71-0958020

### **Synthesis and photocatalysis study of brookite phase titanium dioxide nanoparticles.**

**Publication Date: 2007**

**Descriptors:** Titanium dioxide; Phases; Brookite; Nanoparticles; Coatings; Synthesis; Rutile; Scanning electron microscopy; Binders; Anatase; Nanostructure; Binders (adhesives); Adhesion; Paints; Painting; Photocatalysis; Scratch resistance; Calcination; Degradation; Glass; Protective coatings; Transmission electron microscopy; Crystallites; Crystal structure; Estimates; Diffraction; Thermal

## Appendix A-5. Irrelevant Titles

**analysis;** Morphology; Fibers; Pigments  
**Subj Catg:** 71, General and Nonclassified

7/8/157 (Item 51 from file: 32)

METADEX

(c) 2009 CSA. All rights reserved.

0004503441 IP Accession No: 200904-71-0990614

**Study on preparation of Eu(3+) doped titania nano crystals and photoluminescence property**

**Publication Date: 2008**

**Descriptors:** Titanium dioxide; Nanocrystals; Spectra; Precursors; Crystals; Photoluminescence; Phase transformations; Particle size; Sol gel **process**; Doping

**Subj Catg:** 71, General and Nonclassified

7/8/158 (Item 52 from file: 32)

METADEX

(c) 2009 CSA. All rights reserved.

0004442664 IP Accession No: 200904-61-0990087

**Photocatalytic property of cerium-doped titanium dioxide nanotubes**

**Publication Date: 2008**

**Descriptors:** Nanostructure; Nanotubes; Titanium dioxide; Photocatalysis; Nanocomposites; Nanomaterials; Degradation; Oranges; Aluminum oxide; Anodic; Optimization; Cerium; Sol gel **process**; Titanium; Mechanical engineering; Scanning electron microscopy

**Subj Catg:** 61, Engineering Components and Structures

7/8/160 (Item 54 from file: 32)

METADEX

(c) 2009 CSA. All rights reserved.

0004306296 IP Accession No: 200903-23-0770942

**Voltammetric determination of trace doxorubicin at a nano- titania/nafion composite film modified electrode in the presence of cetyltrimethylammonium bromide**

**Publication Date: 2009**

**Descriptors:** Nanostructure; Doxorubicin; Nanocomposites; Nanomaterials; Reduction; Electrodes; Optimization; Reproducibility; Evaporation; Solvents; **Human**; Glassy carbon; Cetyltrimethylammonium bromide; **Exposure**; Recovery; Assaying; Dispersion

**Subj Catg:** 23, Analysis

7/8/161 (Item 55 from file: 32)

METADEX

(c) 2009 CSA. All rights reserved.

0004281643 IP Accession No: 200903-71-0514193

**Structure, morphology and corrosion resistance of nano-sized titanium dioxide coating**

## Appendix A-5. Irrelevant Titles

**on low carbon steel surface**

**Publication Date: 2008**

**Descriptors:** Nanostructure; Coating; X-ray photoelectron spectroscopy; Titanium dioxide; Nanomaterials; Protective coatings; Low carbon steels; Nanocomposites; Morphology; Corrosion resistance; Fracture mechanics; Scanning electron microscopy; Stress corrosion cracking; Blackening; Titanium; Heat treatment ; Sol gel **process**; Iron; Spectra; Corrosion tests; Anatase; Corrosion potential; Corrosion

**Subj Catg:** 71, General and Nonclassified

7/8/162 (Item 56 from file: 32)

METADEX

(c) 2009 CSA. All rights reserved.

0004277286 IP Accession No: 200903-32-0694025

**Surface-modification of indium tin oxide nanoparticles with titanium dioxide by a nonaqueous process and its photocatalytic properties**

**Publication Date: 2009**

**Descriptors:** Nanoparticles; Indium tin oxide; Photocatalysis; Titanium dioxide; Photodegradation; pH; Tetrachlorides; Optimization; Precursors; Titanium; Benzyl alcohol; Rhodamine; Morphology

**Subj Catg:** 32, Physical Properties

7/8/163 (Item 57 from file: 32)

METADEX

(c) 2009 CSA. All rights reserved.

0004235179 IP Accession No: 200903-32-0694048

**Preparation, characterization of Au (or Pt)-loaded titania nanotubes and their photocatalytic activities for degradation of methyl orange**

**Publication Date: 2009**

**Descriptors:** Titanium dioxide; Nanotubes; Gold; Photocatalysis; Nanostructure; Platinum; Specific surface; Degradation; Photocatalysts; Oranges; Surface chemistry; X-rays; Adsorption; Phase transformations; X-ray photoelectron spectroscopy ; Rutile; Walls; Roasting; Nanomaterials; Reflectance; Diffraction; Transmission electron microscopy; Catalysts; Diffusion; Mercury lamps; Anatase; Spectroscopy; Calcination; Photoelectron spectroscopy; Crystal structure

**Subj Catg:** 32, Physical Properties

7/8/164 (Item 58 from file: 32)

METADEX

(c) 2009 CSA. All rights reserved.

0004111401 IP Accession No: 200903-46-0771960

**Effect of the Ion Concentration in Electrolyte on the Microstructure of Titania Nanotubes**

**Publication Date: 2008**

**Descriptors:** Titanium dioxide; Nanotubes; Arrays; Electrolytes; Anodizing; Heat treatment;

## Appendix A-5. Irrelevant Titles

Photocatalysis; Anatase; Ion concentration; Microstructure; Titanium oxides; Synthesis; Decomposition; Titanium; Scanning electron microscopy; Rhodamine

**Subj Catg:** 46, Nonferrous Alloy Production

7/8/165 (Item 59 from file: 32)

METADEX

(c) 2009 CSA. All rights reserved.

0004107034 IP Accession No: 200903-23-0770946

**Determination of trace molybdenum in biological and water samples by graphite furnace atomic absorption spectrometry after separation and preconcentration on immobilized titanium dioxide nanoparticles**

**Publication Date:** 2009

**Descriptors:** Titanium dioxide; Nanoparticles; Molybdenum; Graphite; Furnaces; Atomic absorption **analysis**; pH; **Separation**; Biological; Standard deviation; Optimization; Silica gel; Flow rate; Cations; Eluents; Enrichment

**Subj Catg:** 23, Analysis

7/8/166 (Item 60 from file: 32)

METADEX

(c) 2009 CSA. All rights reserved.

0004056104 IP Accession No: 200902-12-0357741

**X-ray absorption spectroscopy studies of phase transformations and amorphicity in nanotitania powder and silica-titania core-shell photocatalysts**

**Publication Date:** 2008

**Descriptors:** Titanium dioxide; Nanostructure; Anatase; Rutile; Titanium; Photocatalysis; Crystallization; X-rays; Nanocomposites; Crystal defects; Photocatalysts; Nanomaterials; Absorption spectroscopy; Phase transformations; Architecture ; Trends; Crystal structure; Sol gel **process**; Transformations; Catalysts; Interatomic distance; Diffraction patterns; Correlation; Silica glass; Nanocrystals; Specific surface; Cobalt; Vacancies; Silicon dioxide; Glassy

**Subj Catg:** 12, Crystal Properties

7/8/167 (Item 61 from file: 32)

METADEX

(c) 2009 CSA. All rights reserved.

0004027978 IP Accession No: 200902-71-0436473

**The effect of doping titanium dioxide nanoparticles on phase transformation, photocatalytic activity and anti-bacterial properties.**

**Publication Date:** 2007

**Descriptors:** Titanium dioxide; Nanoparticles; Photocatalysis; Scanning electron microscopy; Rutile; Doping; Anatase; Silver; Cations; Nanostructure; Dopants; Phase transformations; Sol gel **process**; X-ray photoelectron spectroscopy; Devices; Metalorganic

## Appendix A-5. Irrelevant Titles

chemical vapor deposition; Anions; X-rays; Transmission electron microscopy; Crystallites; Methylene blue; Infrared spectroscopy; Photovoltaic cells; Escherichia coli; Spintronics; Solar cells; Remediation; Organic compounds; Crystal lattices; Chromium  
**Subj Catg:** 71, General and Nonclassified

7/8/168 (Item 62 from file: 32)

METADEX

(c) 2009 CSA. All rights reserved.

0004027964 IP Accession No: 200902-71-0436502

**The efficacy of surface modified nano titanium dioxide against photocatalytic activity from the ultra violet irradiation.**

**Publication Date: 2007**

**Descriptors:** Titanium dioxide; Nanostructure; Free radicals; Coating; Deoxyribonucleic acid; **Exposure;** Nanomaterials; Wavelengths; Irradiation; Nanocomposites; Dyes; Brushes; Electrophoresis; Rutile; Scavengers; Coated particles; In vitro testing; Estimates; Damage; Spectra; Deionization; Spectroscopy; Surface chemistry; Superplastic forming; Photocatalysis; Breakage; Gravimetric **analysis;** Chain scission; Nanoparticles; Color

**Subj Catg:** 71, General and Nonclassified

7/8/169 (Item 63 from file: 32)

METADEX

(c) 2009 CSA. All rights reserved.

0004005405 IP Accession No: 200902-12-0433125

**Soft-Chemical Synthesis of Nanometer-Thick Carbon-Coated Titania: Effect of Carbon-Coating on the Photocatalytic Activity of TiO<sub>2</sub>**

**Publication Date: 2008**

**Descriptors:** Titanium dioxide; Titanium oxides; Carbon; Photocatalysis; X-rays; Dehydration; Atomic beam spectroscopy; Titanium; Diffraction; Metal oxides; Anatase; Spectroscopy; Synthesis; Surface chemistry; Spectroscopic analysis ; Carbohydrates; Atomic absorption analysis; Pollutants; Sulfuric acid; Positioning; Electron microscopy

**Subj Catg:** 12, Crystal Properties

7/8/170 (Item 64 from file: 32)

METADEX

(c) 2009 CSA. All rights reserved.

0003998650 IP Accession No: 200902-12-0432466

**Oriented single crystalline titanium dioxide nanowires**

**Publication Date: 2008**

**Descriptors:** Nanowires; Titanium dioxide; Crystal structure; Titanium; Nanostructure; Foils (structural shapes); Arrays; Solar cells; Synthesis; Photovoltaic cells; Single crystals; Nanoparticles; Sodium; Devices; Titanates; Walls; Transformations; Nanomaterials; Morphology; Electron transport; Carpets; Anatase; Nanotubes; Calcination; Photocatalysis; Decoration; Performance enhancement; Nanocomposites; Dyes

## Appendix A-5. Irrelevant Titles

**Subj Catg:** 12, Crystal Properties

7/8/171 (Item 65 from file: 32)

METADEX

(c) 2009 CSA. All rights reserved.

0003930366 IP Accession No: 200902-71-0359453

**Aligned Titania Nanotubes as an Intercalation Anode Material for Hybrid Electrochemical Energy Storage**

**Publication Date: 2008**

**Descriptors:** Titanium dioxide; Electrolytic cells; Cathodes; Anodes; Uptakes; Transport; Lithium; Anode effect; Alignment; Energy storage; Nanotubes; Density; Safes ; Specific surface; Carbon; Energy density; Dendritic structure; Anions; Wall thickness; Solid electrolytes; Tubes; Electrochemical cells; Electrolytes; Intercalation; Penetration depth; Electrochemistry; Interphase; Ion diffusion; Optimization

**Subj Catg:** 71, General and Nonclassified

7/8/172 (Item 66 from file: 32)

METADEX

(c) 2009 CSA. All rights reserved.

0003787020 IP Accession No: 200812-12-2383200

**Synthesis and Control of Physical Properties of Titania Nanoparticles as a Function of Synthetic Parameters**

**Publication Date: 2008**

**Descriptors:** Titanium dioxide; Reaction time; pH; Nanoparticles; Doping; Anatase; Synthesis; Physical properties; Transition metals; Calcination; Alkoxides; Chromium; Nickel; Sol gel **process**; Iron; Sole; Manganese; Copper; Zinc; Grain size; Phase transformations; Photoluminescence; Surface area

**Subj Catg:** 12, Crystal Properties

7/8/173 (Item 67 from file: 32)

METADEX

(c) 2009 CSA. All rights reserved.

0003761249 IP Accession No: 200812-34-2354250

**Pt/titania-nanotube: A potential catalyst for CO<sub>2</sub> adsorption and hydrogenation**

**Publication Date: 2008**

**Descriptors:** Platinum; TNT; Catalysts; Surface chemistry; Carbon dioxide; Adsorption; X-rays; Scanning electron microscopy; Hydrogenation; Nanoparticles; Reduction; Diffraction; Temperature programmed desorption; Dispersion; Deposition; Methane; Infrared spectroscopy; Isotherms; Desorption; Photochemical; Photoelectron spectroscopy; Surface area

**Subj Catg:** 34, Chemical and Electrochemical Properties

## Appendix A-5. Irrelevant Titles

7/8/174 (Item 68 from file: 32)

METADEX

(c) 2009 CSA. All rights reserved.

0003744961 IP Accession No: 200812-12-2383145

**Polymer Embedded Nanocrystalline Titania Sorbent for <sup>99</sup>Mo-<sup>99m</sup>Tc Generator**

**Publication Date: 2008**

**Descriptors:** Titanium dioxide; Adsorbents; Titanium; Generators; Sorbents; Nanocrystals; Chlorides; Infrared absorption; Rutile; Crystallites; Micrographs; Elution; Transmission electron microscopy; Dispersion; Diffraction patterns; Spectra ; Shelf life; Specifications; pH; Surface chemistry; Precursors; Columns ( **process**); Pore size; Photomicrographs; X-rays; Adsorption; Isopropyl alcohol; Porosity; Surface area; Saline solutions

**Subj Catg:** 12, Crystal Properties

7/8/175 (Item 69 from file: 32)

METADEX

(c) 2009 CSA. All rights reserved.

0003744163 IP Accession No: 200812-71-2286529

**Plasma electrolytic deposition of titanium dioxide nanorods and nano-particles**

**Publication Date: 2008**

**Descriptors:** Nanostructure; Nanocomposites; Nanomaterials; Electrodeposition; Nanorods; Titanium dioxide; Liquids; Barometric pressure; Discharge; Coatings; Atmospheric pressure; Solar cells; Dioxides; Photovoltaic cells; Titanium; Morphology

**Subj Catg:** 71, General and Nonclassified

7/8/176 (Item 70 from file: 32)

METADEX

(c) 2009 CSA. All rights reserved.

0003742458 IP Accession No: 200812-34-2354265

**Photodegradation of dye pollutant under UV light by nano-catalyst doped titania thin films**

**Publication Date: 2008**

**Descriptors:** Titanium dioxide; Nanostructure; Manganese; Doping; Annealing; Photocatalysis; Thin films; X-ray photoelectron spectroscopy; Dyes; Contact angle; Crystallites; Conduction band; Sol gel **process**; Nanomaterials ; Rate constants; Scavenging; Degradation; Energy bands; Spectroscopy; Spectroscopic **analysis**; Charge carriers; Pollutants; Methylene blue; Scanning electron microscopy; Photodegradation; Surface area;

**Exposure;** Nanocomposites

**Subj Catg:** 34, Chemical and Electrochemical Properties

7/8/177 (Item 71 from file: 32)

METADEX

(c) 2009 CSA. All rights reserved.

0003695595 IP Accession No: 200812-34-2354268

## Appendix A-5. Irrelevant Titles

### **Grafted multifunctional titanium dioxide nanotube membrane: Separation and photodegradation of aquatic pollutant**

**Publication Date: 2008**

**Descriptors:** Nanostructure; Titanium dioxide; Nanomaterials; Nanocomposites; Membranes; Hydroxyapatite; Grafting; Filtration; Photodegradation; Channels; Dioxides; Fouling; Distilled **water**; Deposition; Humic acids; **Separation** ; Permeability; Energy of solution; Energy use; Anatase; Photocatalysis; Irradiation; Pollutants; Microfiltration; Aluminum oxide; Stability

**Subj Catg:** 34, Chemical and Electrochemical Properties

7/8/178 (Item 72 from file: 32)

METADEX

(c) 2009 CSA. All rights reserved.

0003686387 IP Accession No: 200812-12-2383215

### **Fabrication of Thin Film Titania with Nanopores, Nanopoles, and Nanopipes by Nanoporous Alumina Template**

**Publication Date: 2008**

**Descriptors:** Nanostructure; Titanium dioxide; Nanomaterials; Nanocomposites; Aluminum oxide; Thin films; Polymethyl methacrylates; Arrays; Anodizing; Lithography ; Molds; Solar cells; Poles; Aspect ratio; Photocatalysis; Photovoltaic cells; Detection; Porosity; Approximation; Pipe

**Subj Catg:** 12, Crystal Properties

7/8/179 (Item 73 from file: 32)

METADEX

(c) 2009 CSA. All rights reserved.

0003679840 IP Accession No: 200812-12-2382945

### **Deposition of anatase titania onto carbon encapsulated magnetite nanoparticles**

**Publication Date: 2008**

**Descriptors:** Titanium dioxide; Photocatalysis; Magnetite; Carbon; Encapsulation; Hydroxyl groups; Phenol; Magnetic fields; Electron microscopes; Transmission electron microscopy; Contact; Degradation; Deposition; Diffractometers; Mathematical models; Fourier transforms; Anatase; Electric contacts; Slurries; Iron oxides; X-rays; **Aqueous** solutions; Infrared spectrometers; **Contamination**; Nanoparticles

**Subj Catg:** 12, Crystal Properties

7/8/180 (Item 74 from file: 32)

METADEX

(c) 2009 CSA. All rights reserved.

0003626442 IP Accession No: 200811-71-1972534

### **The study of photocatalysis under ultraviolet + visible two-beam light irradiation using undoped nano-titanium dioxide**

## Appendix A-5. Irrelevant Titles

**Publication Date: 2008**

**Descriptors:** Nanostructure; Photocatalysis; Nanomaterials; Light irradiation; Nanocomposites; Ultraviolet; Titanium dioxide; Spectroscopy; X-rays; X-ray photoelectron spectroscopy; Conduction band; Phenol; Dioxides; Electron microscopes; Diffraction; Transmission electron microscopy; Raman spectroscopy; Oranges; Surface chemistry; Photoelectron spectroscopy; Irradiation; Photoluminescence; Photodegradation

**Subj Catg:** 71, General and Nonclassified

7/8/181 (Item 75 from file: 32)

METADEX

(c) 2009 CSA. All rights reserved.

0003619278 IP Accession No: 200811-71-2171097

**Synthesis and characterization of silica-titania nanocomposite via a combination of sol-gel and mechanochemical process**

**Publication Date: 2008**

**Descriptors:** Nanostructure; Scanning electron microscopy; Nanomaterials; Silicon dioxide ; Nanocomposites; Sol gel **process**; Particle size; Bonding; Spectrometers; Roasting; Diffraction; Estimates; Morphology; Fourier transforms; Anatase; Synthesis; Crystal structure; X-rays; Phases; Amorphous structure; Infrared; Chemical properties

**Subj Catg:** 71, General and Nonclassified

7/8/182 (Item 76 from file: 32)

METADEX

(c) 2009 CSA. All rights reserved.

0003563865 IP Accession No: 200811-71-2225028

**Preparation and Application of Stilbite Loading Nano- titanium Dioxide Photocatalyst**

**Publication Date: 2008**

**Descriptors:** Titanium dioxide; Waste water; Photocatalysis; Nanostructure; Dyes; Azo; Nanocomposites; Nanomaterials; Dioxides; Decoloring; Roasting

**Subj Catg:** 71, General and Nonclassified

7/8/183 (Item 77 from file: 32)

METADEX

(c) 2009 CSA. All rights reserved.

0003518537 IP Accession No: 200811-71-2104056

**Enhanced ductility in thermally sprayed titania coating synthesized using a nanostructured feedstock**

**Publication Date: 2005**

**Descriptors:** Titanium dioxide; Coating; Nanostructure; Abrasion resistance; Abrasion resistant coatings; Microstructure; Wear; Ductility; Feedstock; Scars; Wear resistance; Fracture toughness; Bonding strength; Flame spraying; Roughness ; Cracks; Plastic deformation; Diamond pyramid hardness; Artifacts; Nanomaterials; Protective coatings; Deformation wear; Arresters; Deformation mechanisms; Fracture mechanics; Abrasive wear; Oxy-fuel; Scanning electron microscopy; Porosity; Crack propagation

## Appendix A-5. Irrelevant Titles

**Subj Catg:** 71, General and Nonclassified

7/8/184 (Item 78 from file: 32)

METADEX

(c) 2009 CSA. All rights reserved.

0003322393 IP Accession No: 200810-71-1942607

**Study of synthesis and photocatalytic property of nano- titania powder by H<sub>2</sub>/air flame diffusion combustion**

**Publication Date: 2008**

**Descriptors:** Titanium dioxide; Nanostructure; Photocatalysis; Nanocomposites; Nanomaterials; Nanoparticles; Synthesis; Dispersions; Tetrachlorides; Optimization; Diffusion flames; Precursors; Transmission electron microscopy; Combustion; Diffusion; Titanium

**Subj Catg:** 71, General and Nonclassified

7/8/185 (Item 79 from file: 32)

METADEX

(c) 2009 CSA. All rights reserved.

0002529212 IP Accession No: 200808-23-1240174

**Surface-Assisted Laser Desorption/Ionization Mass Spectrometry on Titania Nanotube Arrays**

**Publication Date: 2008**

**Descriptors:** Titanium dioxide; Nanostructure; NTA; Nanocomposites; Arrays; Nanomaterials ; Deposition; Lasers; Ionization; Mass spectrometry; Desorption; Quantitative analysis; Reproducibility; Anodizing; Peptides

**Subj Catg:** 23, Analysis

7/8/186 (Item 80 from file: 32)

METADEX

(c) 2009 CSA. All rights reserved.

0002528171 IP Accession No: 200808-71-1089732

**Preparation and optical properties of titania/epoxy nanocomposite coatings**

**Publication Date: 2008**

**Descriptors:** Nanostructure; Titanium dioxide; Nanocomposites; Nanomaterials; Coatings; Nanoparticles; Refractive index; Refractivity; Sol gel **process**; Dispersion; Thin films; Optical properties; Cracks; Lithium; Surfactants

**Subj Catg:** 71, General and Nonclassified

7/8/187 (Item 81 from file: 32)

METADEX

(c) 2009 CSA. All rights reserved.

0002528133 IP Accession No: 200808-71-1221748

## Appendix A-5. Irrelevant Titles

### **Preparation and Characterization of the Composite Nano-material of Titanium Dioxide/Carbon Nanotubes (TiO<sub>2</sub>/CNT)**

**Publication Date: 2008**

**Descriptors:** Nanostructure; Titanium dioxide; Nanocomposites; Nanomaterials; Thin films; Scanning electron microscopy; Oranges; Electrodes; Carbon; Precursors; Sol gel **process**; Particulate composites; Spectroscopy; Electrochemical impedance spectroscopy; Titanium; Spectrophotometry

**Subj Catg:** 71, General and Nonclassified

7/8/188 (Item 82 from file: 32)

METADEX

(c) 2009 CSA. All rights reserved.

0002525717 IP Accession No: 200808-12-1012563

### **Electrochemical fabrication of Sn nanowires on titania nanotube guide layers**

**Publication Date: 2008**

**Descriptors:** Titanium dioxide; Nanostructure; Nanowires; Tin; Nanocomposites; Nanomaterials; Crystallites; Density; Electrodeposition; Electrochemical fabrication; High aspect ratio; Florence; Electrochemistry

**Subj Catg:** 12, Crystal Properties

7/8/189 (Item 83 from file: 32)

METADEX

(c) 2009 CSA. All rights reserved.

0002525569 IP Accession No: 200808-56-1012759

### **HRTEM in situ observation of nanometer-sized titania crystal structures variation by electron-beam irradiation**

**Publication Date: 2008**

**Descriptors:** Titanium dioxide; Grains; Irradiation; Rutile; Crystal structure; Crystals; Amorphous structure; Images; Anatase; Asymmetry; Crystallization; Sol gel **process**; Electron microscopy

**Subj Catg:** 56, Thermal Treatment

7/8/190 (Item 84 from file: 32)

METADEX

(c) 2009 CSA. All rights reserved.

0002525043 IP Accession No: 200808-61-1096110

### **Effects of hydroxyapatite additive content on the bioactivity and biomechanical compatibility of bioactive nano-titania ceramics**

**Publication Date: 2008**

**Descriptors:** Nanostructure; Ceramics; Nanomaterials; Nanocomposites; Hydroxyapatite; Additives; Biochemistry; Surgical implants; Biomedical materials; Biomechanics; Inhibitors; Biocompatibility; Culture; Particle size; Grains; Compressive strength; Bones; Loose powder sintering; Bend strength; Mechanical properties; Sintering; Mechanical tests; Pressureless

## Appendix A-5. Irrelevant Titles

sintering; Osteoblasts; Grain growth; Grain size; Modulus of elasticity

**Subj Catg:** 61, Engineering Components and Structures

7/8/191 (Item 85 from file: 32)

METADEX

(c) 2009 CSA. All rights reserved.

0002523825 IP Accession No: 200808-71-0954469

**Comparative study of antimicrobial and photocatalytic activity in titania encapsulated composite nanoparticles with different dopants**

**Publication Date: 2008**

**Descriptors:** Titanium dioxide; Nanoparticles; Photocatalysis; Encapsulation; Dopants; Nickel ferrites; Hydrolysis; Ferrite; Tungsten; Reverse micelles; Inhibition; Strength

**Subj Catg:** 71, General and Nonclassified

7/8/192 (Item 86 from file: 32)

METADEX

(c) 2009 CSA. All rights reserved.

0002515747 IP Accession No: 200807-61-0863421

**TITANIUM DIOXIDE (TiO<sub>2</sub>) NANOPARTICLES FILLED POLY(D,L LACTIC ACID) (PDLLA) MATRIX COMPOSITES FOR BONE TISSUE ENGINEERING**

**Publication Date: 2007**

**Descriptors:** Titanium dioxide; Nanoparticles; Nanostructure; Hydroxyapatite; Biochemistry; Bones; Biomedical materials; Magnesium; Tissue engineering; Particulate composites; Nanocrystals; Immersion; Nanomaterials; Surgical implants; Solvents; Viability; Lactic acid; Biocompatibility; Assaying; Nanocomposites

**Subj Catg:** 61, Engineering Components and Structures

7/8/193 (Item 87 from file: 32)

METADEX

(c) 2009 CSA. All rights reserved.

0002506224 IP Accession No: 200807-54-0951497

**Synthesis of high grade structure integrated material made of titania nano tube and nano particles**

**Publication Date: 2007**

**Descriptors:** Nanostructure; Titanium dioxide; Nanomaterials; Nanocomposites; TNT; Tubes; Ultrasonic testing; Silver; Ethyl alcohol; Transmission electron microscopy ; Images; Oxides; Carbon; Technical colleges; Anisotropy; Boron nitride; Powder metallurgy; Chemical vapor deposition; Reduction; Rods; Ethanol; Silver oxides; Rejection; Thermal analysis; Drying; Pressure vessels ; Generators; Conduction; Anatase; Ultrasound

**Subj Catg:** 54, Powder Technology

7/8/194 (Item 88 from file: 32)

## Appendix A-5. Irrelevant Titles

METADEX

(c) 2009 CSA. All rights reserved.

0002463349 IP Accession No: 200807-71-0950598

**Novel transparent ternary nanocomposite films of trialkoxysilane-capped poly(methyl methacrylate)/zirconia/titania with incorporating networks**

**Publication Date: 2008**

**Descriptors:** Nanostructure; Titanium dioxide; Nanomaterials; Nanocomposites; Polymethyl methacrylates; Zirconium dioxide; Networks; Lithium; Thermal stability; Field emission; Roughness; Thermogravimetric analysis; Titanium; Sol gel **process**; Monomers; Morphology; Coatings; Clusters; Scanning probe microscopy; Mathematical models; Zirconium; Fourier transforms; Infrared spectroscopy; Optical properties; Properties; Photoelectrons; Particulate composites; X-rays; Chains (polymeric); Refractivity

**Subj Catg:** 71, General and Nonclassified

7/8/195 (Item 89 from file: 32)

METADEX

(c) 2009 CSA. All rights reserved.

0002435664 IP Accession No: 200807-32-0950933

**Molecular imprinting and adsorption of metallothionein on nanocrystalline titania membranes**

**Publication Date: 2008**

**Descriptors:** Titanium dioxide; Membranes; Microorganisms; Surface chemistry; Nanocrystals; Molecular imprinting; Adsorption; Quartz crystals; Sol gel **process**; Chemical engineering; Holes; Recognition; Silicon; Proteins ; Selectivity; pH

**Subj Catg:** 32, Physical Properties

7/8/196 (Item 90 from file: 32)

METADEX

(c) 2009 CSA. All rights reserved.

0002409894 IP Accession No: 200807-71-0953739

**Fabrication and characterization of highly-ordered titania nanotubes via electrochemical anodization**

**Publication Date: 2008**

**Descriptors:** Titanium dioxide; Nanotubes; Anodizing; Images; Arrays; Rutile; Electric potential; Annealing; Nanomaterials; Acetic acid; Cathodes; Iron; Voltage; Anatase; Microstructure; Optical properties; Electrolytes; Controlled atmospheres; Crystallinity; Thin films; Germanium; Graphite

**Subj Catg:** 71, General and Nonclassified

7/8/197 (Item 91 from file: 32)

METADEX

(c) 2009 CSA. All rights reserved.

## Appendix A-5. Irrelevant Titles

0002347644 IP Accession No: 200806-71-748442

**A quantitative study of the calcination and sintering of nanocrystalline titanium dioxide and its flexural strength properties**

**Publication Date: 2008**

**Descriptors:** Titanium dioxide; Nanostructure; Sintering (powder metallurgy); Calcination ; Modulus of rupture in bending; Nanomaterials; Flexural strength; **Quantitative analysis;** Sintering; Nanocrystals; Density; Nanocomposites; Compacting; Computer programs; Sol gel **process;** Diffraction; Cold pressing; Microstructural **analysis;** Isopropanol; Aerospace engineering; Software; Titanium base alloys; Deionization; Anatase; Microstructure; Crystal structure; X-rays; Grain size; Scanning electron microscopy; Strength

**Subj Catg:** 71, General and Nonclassified

7/8/198 (Item 92 from file: 32)

METADEX

(c) 2009 CSA. All rights reserved.

0002333543 IP Accession No: 200806-71-810816

**Application of glass shell of absorption ultraviolet with nano-titanium dioxide**

**Publication Date: 2008**

**Descriptors:** Nanostructure; Glass; Nanocomposites; Nanomaterials; Titanium dioxide; Rutile; Ultraviolet; Silicates; Standards; Polytechnics; Absorbing; Sol gel **process;** Ultraviolet radiation; Boron; Dioxides

**Subj Catg:** 71, General and Nonclassified

7/8/199 (Item 93 from file: 32)

METADEX

(c) 2009 CSA. All rights reserved.

0002301286 IP Accession No: 200806-71-748620

**Letter: Flash synthesis of titanium dioxide nanoparticles by strong exothermic reaction between solids without external energy**

**Publication Date: 2008**

**Descriptors:** Titanium dioxide; Titanium; Nanostructure; Combustion synthesis; Nanoparticles; Self-propagating synthesis; Heating; Raw materials; Oxides; Exothermic reactions; Mass production; Gasification; Adiabatic flow; Rutile ; Foils; Nucleation; Cooling; Nanomaterials; Distilled water; Metal oxides; Direct power generation; Electric furnaces; Energy use; Sodium perchlorate; Anatase; Boiling points; Solid phases; Crystal growth; Crystal structure; Energy conservation

**Subj Catg:** 71, General and Nonclassified

7/8/200 (Item 94 from file: 32)

METADEX

(c) 2009 CSA. All rights reserved.

0002293655 IP Accession No: 200806-12-747838

**Hybrid titanium dioxide/PS-b-PEO block copolymer nanocomposites based on sol-gel synthesis**

## Appendix A-5. Irrelevant Titles

**Publication Date: 2008**

**Descriptors:** Titanium dioxide; Block copolymers; Nanocomposites; Sol gel **process**; Atomic force microscopy; Morphology; Images; Construction; Atomic structure ; Molecular structure; Polyamide-imides; Micelles; Oxides; Fourier transforms; Affinity; Forming; Coronas; Spectroscopy; Optical properties; Molecular weight; Precursors; Nanoparticles

**Subj Catg:** 12, Crystal Properties

7/8/201 (Item 95 from file: 32)

METADEX

(c) 2009 CSA. All rights reserved.

0002237656 IP Accession No: 200805-15-687763

**The Synthesis and Characterization of Titania Nanotubes Formed at Various Anodisation Time**

**Publication Date: 2008**

**Descriptors:** Titanium dioxide; Nanotubes; Nanostructure; Scanning electron microscopy; Fluorides; Nanowires; Electrolytes; Field emission; Anodizing; Photoelectrolysis; **Process** parameters; Nanomaterials; Diffraction; Solar cells; pH; Gas sensors; Physical properties; Photocatalysis; X-rays; Photovoltaic cells; Nanocomposites; Mineral resources

**Subj Catg:** 15, Physics of Metals

7/8/202 (Item 96 from file: 32)

METADEX

(c) 2009 CSA. All rights reserved.

0002231722 IP Accession No: 200805-12-685832

**Synthesis and performance of novel magnetically separable nanospheres of titanium dioxide photocatalyst with egg-like structure**

**Publication Date: 2008**

**Descriptors:** Titanium dioxide; Photocatalysis; Nanospheres; Silicon dioxide; Magnetic fields; Nanoparticles; Combustion; Recycled materials; Electron microscopes ; Magnetic properties; Transmission electron microscopy; Degradation; Catalysts; Carriers; Diffractometers; Wastewater treatment; Forming; Encapsulation; Oranges; Catalysis; Reverse micelles; Surface chemistry; Aggregates; Nickel ferrites; Precipitation; X-rays; Reproducibility; Repeatability; Phase transformations

**Subj Catg:** 12, Crystal Properties

7/8/203 (Item 97 from file: 32)

METADEX

(c) 2009 CSA. All rights reserved.

0002229338 IP Accession No: 200805-71-490427

**Strong electrorheological effect of surface-modified titania nano-particles.**

**Publication Date: 2006**

**Descriptors:** Titanium dioxide; Nanostructure; Nanocomposites; Nanomaterials; Fluid dynamics; Fluid flow; Fluids; Wettability; Contact; Yield stress; Sol gel **process**; Stress concentration; Direct current; Dispersing; Contact stresses

## Appendix A-5. Irrelevant Titles

**Subj Catg:** 71, General and Nonclassified

7/8/204 (Item 98 from file: 32)

METADEX

(c) 2009 CSA. All rights reserved.

0002218167 IP Accession No: 200805-34-685776

**Sol-gel route to advanced nanoelectrode arrays (NEA) based on titania gold nanocomposites**

**Publication Date: 2008**

**Descriptors:** Nanostructure; Titanium dioxide; Nanocomposites; Nanomaterials; Membranes; Arrays; Self assembly; Conduction; Gold; Calibration; X-ray photoelectron spectroscopy; Electrodes; Sol gel **process**; Voltammetry; Dispersion; Deposition; Diffusion; Evaporation; Oxides; Forming; Precursors; Pore size; Adjustment; Ceramics; Porosity; Atomic force microscopy; Control surfaces

**Subj Catg:** 34, Chemical and Electrochemical Properties

7/8/205 (Item 99 from file: 32)

METADEX

(c) 2009 CSA. All rights reserved.

0002191011 IP Accession No: 200805-71-683913

**Preparation of aligned titania nanowires with an aligned carbon nanotube composite template**

**Publication Date: 2008**

**Descriptors:** Titanium dioxide; Nanowires; Alignment; Nanostructure; Hydrogels; Nanomaterials; Carbon nanotubes; Polymerization; Lithium; Sol gel **process**; Alcohols; Education; Calcines; Materials **processing**; Chemical reactions; Nanoparticles; Nanocomposites; Multi wall carbon nanotubes

**Subj Catg:** 71, General and Nonclassified

7/8/206 (Item 100 from file: 32)

METADEX

(c) 2009 CSA. All rights reserved.

0002168557 IP Accession No: 200805-71-685712

**Photocatalytic activities of nanocrystalline Si-modified titania xerogels prepared by the glycothermal method**

**Publication Date: 2008**

**Descriptors:** Titanium dioxide; Xerogels; Photocatalysis; Dyes; Catalysts; Catalysis; Nanocrystals; Decomposition; Surface area; Silicon; Crystallites; Dispersion; Drying; Zeta potential; Cationic dyes; Evaporation; Photocatalysts; Materials **processing**; Hydrocarbons; Coagulation; Thermal stability; Surface charge

**Subj Catg:** 71, General and Nonclassified

## Appendix A-5. Irrelevant Titles

7/8/207 (Item 101 from file: 32)

METADEX

(c) 2009 CSA. All rights reserved.

0002095515 IP Accession No: 200805-12-685830

**Growth mechanism of titanium dioxide nanowires for dye-sensitized solar cells**

**Publication Date: 2008**

**Descriptors:** Nanowires; Nanotubes; Titanium dioxide; Anatase; Transformations; Titanium; Solar cells; Photovoltaic cells; Dyes; Crystal structure; Foils (structural shapes); Foils; Morphology; Oxidation; Microstructure; Chemical engineering ; Exfoliation; Pathways; Dehydration; Bonding

**Subj Catg:** 12, Crystal Properties

7/8/208 (Item 102 from file: 32)

METADEX

(c) 2009 CSA. All rights reserved.

0002083053 IP Accession No: 200805-34-551258

**Fabrication of nickel oxide-embedded titania nanotube array for redox capacitance application**

**Publication Date: 2008**

**Descriptors:** Titanium dioxide; Nanostructure; Nanocomposites; Nanomaterials; Nickel; Capacitance; Scanning electron microscopy; Arrays; Nickel oxides; Titanium; Electrodes; Diffraction; Tubes; X-rays; Dispersions; Walls; Carbon; Glycols ; Field emission; Heating; Morphology; Microstructure; Anodizing; Mechanical engineering; Hydroxides; Hydrothermal reactions; Energy dispersive; Electrolytes; Expansion; Cathodes

**Subj Catg:** 34, Chemical and Electrochemical Properties

7/8/209 (Item 103 from file: 32)

METADEX

(c) 2009 CSA. All rights reserved.

0002049719 IP Accession No: 200805-12-551531

**Characterization of silver nanoparticles synthesized on titanium dioxide fine particles**

**Publication Date: 2008**

**Descriptors:** Titanium dioxide; Silver; Nanoparticles; Standards; Scanning electron microscopy; Scanning transmission electron microscopy; Transmission electron microscopy; X-rays; Nanocomposites; X-ray photoelectron spectroscopy; Light scattering; Reduction; Diffraction; Microscopy; Dynamic tests; Absorption spectroscopy; Dynamics; Spectroscopy; Particle size distribution; Surface chemistry; Photoelectron spectroscopy; Reducing agents

**Subj Catg:** 12, Crystal Properties

7/8/210 (Item 104 from file: 32)

METADEX

(c) 2009 CSA. All rights reserved.

0002039935 IP Accession No: 200805-46-491634

## Appendix A-5. Irrelevant Titles

### **Eu<sup>2+</sup>/Gd<sup>3+</sup>-codoped nanocrystalline titania catalyst and its photocatalytic activity under natural light**

**Publication Date: 2007**

**Descriptors:** Titanium dioxide; Catalysts; Photocatalysis; Nanocrystals; Chemical engineering; Oranges; Spectra; Diffraction; Optimization; Energy transfer; Light irradiation; X-rays; Sol gel **process**; Mass ratios; Photodegradation; Electron microscopy; Excitation

**Subj Catg:** 46, Nonferrous Alloy Production

7/8/212 (Item 106 from file: 32)

METADEX

(c) 2009 CSA. All rights reserved.

0002019719 IP Accession No: 200804-71-469624

### **The preparation and characterization of organic solvent dispersible polyaniline coated titania hybrid nanocomposites**

**Publication Date: 2008**

**Descriptors:** Titanium dioxide; Polyanilines; Nanostructure; Resistivity; Solvents; Conductivity; Nanocomposites; Sodium; Oxidants; Industrial research; Nanomaterials; P-n junctions; Electrical resistivity; Coating; Irradiation; X-rays; Electrical conductivity; Oxidizing agents; Electron microscopy

**Subj Catg:** 71, General and Nonclassified

7/8/213 (Item 107 from file: 32)

METADEX

(c) 2009 CSA. All rights reserved.

0002019330 IP Accession No: 200804-71-469223

### **The formation mechanism of titania nanotube arrays in hydrofluoric acid electrolyte**

**Publication Date: 2008**

**Descriptors:** Titanium dioxide; Nanostructure; Tubes; Titanium; Electrolytes; Arrays; Nanomaterials; Images; Hydrofluoric acid; Porosity; Nanocomposites; Current density; Pore formation; Lithium; Foils; Morphology; Oxides; Foils (structural shapes)

**Subj Catg:** 71, General and Nonclassified

7/8/214 (Item 108 from file: 32)

METADEX

(c) 2009 CSA. All rights reserved.

0002002837 IP Accession No: 200804-71-469697

### **SOL-GEL-MICROEMULSION TITANIA NANOPARTICLES AND ITS PERFORMANCE IN PHOTOCATALYTIC OXIDATION OF ACETIC ACID**

**Publication Date: 2008**

**Descriptors:** Titanium dioxide; Photocatalysis; Acetic acid; Pollutants; Degradation; Catalysts; Oxidation; Catalysis; Crystal structure; Nanoparticles; Carbon; Colon; Rutile;

## Appendix A-5. Irrelevant Titles

Water purification; Sol gel **process**; Diffraction patterns; Low concentrations; Surface structure; Anatase; Reverse micelles; Irradiation; X-rays; Carbon dioxide; Organic compounds

**Subj Catg:** 71, General and Nonclassified

7/8/215 (Item 109 from file: 32)

METADEX

(c) 2009 CSA. All rights reserved.

0001978693 IP Accession No: 200804-71-356932

**Preparation and its application of titania nanotube composite film electrodes in dye-sensitized solar cells.**

**Publication Date: 2008**

**Descriptors:** Titanium dioxide; Nanostructure; Dyes; Electrodes; Nanomaterials; Solar cells; Photovoltaic cells; Nanocomposites; Porosity; Density; Photoelectric effect; Photocurrent; Roasting; Sun; Photovoltages; Chemical engineering; Pore size; Surface area; Conversion

**Subj Catg:** 71, General and Nonclassified

7/8/216 (Item 110 from file: 32)

METADEX

(c) 2009 CSA. All rights reserved.

0001951031 IP Accession No: 200804-71-378662

**Nanocarving of Titania as a Diffusion-Driven Morphological Instability**

**Publication Date: 2008**

**Descriptors:** Titanium dioxide; Nanostructure; Instability; Stability; Diffusion; Specific surface; Arrays; Casting; Cations; Potential gradients; Nanomaterials; Morphology; Foundry practice; Transport equations; Foundry engineering; Physical chemistry; Fibers; Nonstoichiometric compounds; Chemical diffusion; Reaction kinetics; Nanocomposites

**Subj Catg:** 71, General and Nonclassified

7/8/217 (Item 111 from file: 32)

METADEX

(c) 2009 CSA. All rights reserved.

0001827703 IP Accession No: 200803-34-258753

**Suppression of dioxin emission in incineration of poly(vinyl chloride) (PVC) as hybridized with titanium dioxide (TiO<sub>2</sub>) nanoparticles**

**Publication Date: 2008**

**Descriptors:** Titanium dioxide; Nanostructure; Polyvinyl chlorides; Dioxins; Nanocomposites; Nanomaterials; Incineration; Combustion; Scanning electron microscopy; Nanoparticles; Emission; Chlorides; Precursors; Standards; Dispersions; Self assembly; Solution blending; Blends; Exhaust gases; Iron; Branched; Emittance; Chains (polymeric); Electric furnaces; Organic compounds; Calibration; Dip coatings; Polymer matrix composites; Agglomerates; Energy dispersive

## Appendix A-5. Irrelevant Titles

**Subj Catg:** 34, Chemical and Electrochemical Properties

7/8/218 (Item 112 from file: 32)

METADEX

(c) 2009 CSA. All rights reserved.

0001806307 IP Accession No: 200803-34-252973

**A novel label-free voltammetric immunosensor for the detection of alpha-fetoprotein using functional titanium dioxide nanoparticles**

**Publication Date: 2008**

**Descriptors:** Nanoparticles; Immunosensors; Titanium dioxide; Surface chemistry; Electrochemical impedance spectroscopy; Electrodes; Dibromides; Gold; Charging; Scanning electron microscopy; Adsorption; Specific surface; Lithium; Antigens; Biosensors; **Analytical** chemistry; Maintenance; Electrostatics; Voltammetry; Electron transfer; Antibodies; Selectivity; Capping; Chemical engineering; Correlation coefficients; Biochemistry; Biocompatibility; Attachment; Assaying; Optimization

**Subj Catg:** 34, Chemical and Electrochemical Properties

7/8/219 (Item 113 from file: 32)

METADEX

(c) 2009 CSA. All rights reserved.

0001804024 IP Accession No: 200803-34-253261

**Nano-titania assisted photoreduction of Cr(VI) The role of the different TiO<sub>2</sub> polymorphs**

**Publication Date: 2008**

**Descriptors:** Titanium dioxide; Photocatalysis; Nanostructure; Photochemistry; Anatase; X-ray photoelectron spectroscopy; Rutile; Nanocrystals; Reaction time; Mathematical **analysis**; Crystallites; Reflectance; Physical chemistry ; **Remediation**; Electrochemistry; Energy levels; Spectra; Formic acid ; Slurries; Coupling (molecular); Surface chemistry; Radicals; Conduction band; Nanocomposites; Chromates; pH; Nanomaterials; Thermodynamics; Phase composition; Diffusion

**Subj Catg:** 34, Chemical and Electrochemical Properties

7/8/220 (Item 114 from file: 32)

METADEX

(c) 2009 CSA. All rights reserved.

0001803979 IP Accession No: 200803-71-188646

**An in situ approach to prepare nanorods of titania -hydroxyapatite (TiO<sub>2</sub>-HAp) nanocomposite by microwave hydrothermal technique**

**Publication Date: 2008**

**Descriptors:** Nanostructure; Titanium dioxide; Nanomaterials; Surgical implants; Hydroxyapatite; Biomedical materials; Nanocomposites; Nanorods; Tissue engineering; Biochemistry; Bones; Genetic algorithms; Orthopedics; Ultrafines; Mechanical properties; Bioceramics; Variability; Microwaves; Ceramics; Strength; Stress distribution; Dental

## Appendix A-5. Irrelevant Titles

implants

**Subj Catg:** 71, General and Nonclassified

7/8/221 (Item 115 from file: 32)

METADEX

(c) 2009 CSA. All rights reserved.

0001800765 IP Accession No: 200803-57-252904

**A method to improve mechanical properties of glass plates by surface-coating titania nanofilms with sol-gel technique**

**Publication Date: 2008**

**Descriptors:** Titanium dioxide; Glass; Nanostructure; Mechanical properties; Rare earth metals; Plates; Sol gel **process**; Anatase; Doping; Nanomaterials; Coating; X-rays; Density; Nanocomposites; Rutile; Spectrometers; Reduction; Atomic force microscopes; Correlation; Film thickness; Diffractometers; Crystallization; Microcracks; Microstructure; Microhardness; Sintering; Fracture toughness; Photoelectrons; Thin films; Surface roughness

**Subj Catg:** 57, Finishing

7/8/222 (Item 116 from file: 32)

METADEX

(c) 2009 CSA. All rights reserved.

0001774552 IP Accession No: 200803-71-188644

**Effects of polymer media on electrospun mesoporous titania nanofibers**

**Publication Date: 2008**

**Descriptors:** Titanium dioxide; Nanostructure; Nanofibers; Electrospinning; Nanomaterials ; Sintering; Nanocomposites; Sol gel **process**; Crystal structure; Electrodes; Needles; **Process** parameters; Titanium; Solvents; Morphology; Alcohols; Ejection; Metal oxides; Electron diffraction; Evaporation; Crystallization; Fibers; Charging; Phase transformations; Solidification

**Subj Catg:** 71, General and Nonclassified

7/8/223 (Item 117 from file: 32)

METADEX

(c) 2009 CSA. All rights reserved.

0001748030 IP Accession No: 200802-34-006757

**Hydrogen production by photocatalytic alcohol reforming employing highly efficient nanocrystalline titania films**

**Publication Date: 2007**

**Descriptors:** Titanium dioxide; Photocatalysis; Nanocrystals; Reforming; Hydrogen **production**; Alcohols; Energy conversion efficiency; Deposition; Photons; Sol gel **process**; Surfactants; Glass; Platinum; Excitation

**Subj Catg:** 34, Chemical and Electrochemical Properties

## Appendix A-5. Irrelevant Titles

7/8/224 (Item 118 from file: 32)

METADEX

(c) 2009 CSA. All rights reserved.

0001694644 IP Accession No: 200801-46-002258

**Nanoindentation and FEM Study on Glass Coated with Titania Nanofilms**

**Publication Date: 2007**

**Descriptors:** Computer simulation; Titanium dioxide; Finite element method; Mathematical models; Nanoindentation; Nanostructure; Film thickness; Modulus of elasticity; Hardness; Sol gel **process**; Glass; Elastic modulus; Nanocomposites; Nanomaterials; Mathematical analysis; Mechanical properties

**Subj Catg:** 46, Nonferrous Alloy Production

7/8/225 (Item 119 from file: 32)

METADEX

(c) 2009 CSA. All rights reserved.

0001694626 IP Accession No: 200801-61-002492

**Nanocrystalline hydroxyapatite/titania coatings on titanium improves osteoblast adhesion**

**Publication Date: 2008**

**Descriptors:** Titanium dioxide; Nanostructure; Hydroxyapatite; Coatings; Biocompatibility ; Surgical implants; Nanomaterials; Nanocomposites; Titanium; Protective coatings; Biomedical materials; Nanocrystals; Orthopedics; Composite coatings; Bones; Crystallites; Adhesion; In vitro testing; Deposition; Adhesion tests; Forming; Hydrothermal treatment; Grain size; Materials engineering

**Subj Catg:** 61, Engineering Components and Structures

7/8/226 (Item 120 from file: 32)

METADEX

(c) 2009 CSA. All rights reserved.

0001691408 IP Accession No: 200712-71-217437

**Synthesis of structured titanium dioxide from carbonaceous templates Preparation of supported nanoscaled titania particles**

**Publication Date: 2007**

**Descriptors:** Titanium dioxide; Nanostructure; Chemical vapor deposition; Nanomaterials; Oxides; Surface chemistry; Nanocomposites; Chlorides; Heating; Comets; Diffraction; Deposition; Carbon fibers; Tubes; X-rays; Decomposition; Scanning electron microscopy; Adsorption; Electron microscopy; Hydrolysis; Conversion

**Subj Catg:** 71, General and Nonclassified

7/8/227 (Item 121 from file: 32)

METADEX

(c) 2009 CSA. All rights reserved.

0001691172 IP Accession No: 200712-12-217464

## Appendix A-5. Irrelevant Titles

### **Structural control on crystal growth of titanate in aqueous system: Selective production of nanostructures of layered titanate and anatase-type titania**

**Publication Date: 2007**

**Descriptors:** Nanostructure; Titanium dioxide; Titanates; Nanomaterials; Nanocomposites; Anatase; Cations; Cationic; Construction; Crystal structure; Sodium; Molecular structure; Titanium compounds; Titanium; Architecture; Agar; Decomposition reactions; Control systems; Assembly; Crystal growth; Precursors; Ureas; Ammonia; Monolayers

**Subj Catg:** 12, Crystal Properties

7/8/228 (Item 122 from file: 32)

METADEX

(c) 2009 CSA. All rights reserved.

0001689731 IP Accession No: 200712-71-522861

### **Preparation of Transition-metal Ion Doped Titania Nanowires and the Visible Photocatalytic Activity**

**Publication Date: 2007**

**Descriptors:** Titanium dioxide; Nanowires; Photocatalysis; Arrays; Nanostructure; Scanning electron microscopy; Specific surface; Anodizing; Chromium; Lithium; Doping; Nanomaterials; Correlation; Absorption spectra; Degradation; Education; Strings; Deposition; Spectra; Oranges; Band spectra ; Machining; Orientation; Ceramics; Aluminum oxide; Nanocomposites

**Subj Catg:** 71, General and Nonclassified

7/8/229 (Item 123 from file: 32)

METADEX

(c) 2009 CSA. All rights reserved.

0001688549 IP Accession No: 200712-34-254248

### **Enhanced photoelectrocatalytic performance of polyoxometalate- titania nanocomposite photoanode**

**Publication Date: 2007**

**Descriptors:** Nanostructure; Titanium dioxide; Nanomaterials; Nanocomposites; Titanium; Arrays; Performance enhancement; Vertical orientation; Carbon; Field emission; Channels; Anodizing; Electrodes; Photoelectric effect; Photocurrent; Mechanical engineering; Diffraction; Degradation; Voltammetry ; Cathodes; Polytechnics; Thermogravimetry; Anatase; Spectroscopy; Crystal structure; X-rays; Pollutants; Scanning electron microscopy; Fourier analysis

**Subj Catg:** 34, Chemical and Electrochemical Properties

7/8/230 (Item 124 from file: 32)

METADEX

(c) 2009 CSA. All rights reserved.

0001686300 IP Accession No: 200712-71-788850

### **Fabrication of titania nanocoatings on ZnS-type phosphors using titanium precursor modified by glacial acetic acid**

## Appendix A-5. Irrelevant Titles

**Publication Date: 2007**

**Descriptors:** Titanium dioxide; Nanostructure; Phosphors; Nanomaterials; Acetic acid; Nanocomposites; Sol gel **process**; Degradation; Precursors; Ligands; Zinc sulfides; Field emission; Titanates; Titanium; Electrostatics; Coatings; Chemical technology; Tetrabutyls; Roads; Encapsulation; Coating; Gelation; Hydrolysis; Bonding

**Subj Catg:** 71, General and Nonclassified

7/8/231 (Item 125 from file: 32)

METADEX

(c) 2009 CSA. All rights reserved.

0001684030 IP Accession No: 200711-71-212313

**Tubular Titania Nanostructures via Layer-by-Layer Self-Assembly**

**Publication Date: 2007**

**Descriptors:** Titanium dioxide; Nanostructure; Nanomaterials; Tubes; Scanning electron microscopy; Nanocomposites; Self assembly; Deposition; Anatase; Polycarbonates; Rutile; Filtration; Diffraction; Polyetherimides; Absorbance; Transmission electron microscopy; Morphology; Degradation; Recycling; Multilayers; Oranges; Catalysis; Charging; Calcination; Precursors; Photocatalysis; Crystal structure; X-rays; Detection; Porosity

**Subj Catg:** 71, General and Nonclassified

7/8/232 (Item 126 from file: 32)

METADEX

(c) 2009 CSA. All rights reserved.

0001683910 IP Accession No: 200711-71-214164

**Synthesis of Nano-sized Barium Titanate Powder by Solid-state Reaction between Barium Carbonate and Titania**

**Publication Date: 2007**

**Descriptors:** Titanium dioxide; Nanostructure; Barium titanates; Nanocomposites; Nanomaterials; Information systems; Uranium; Surface area; Calcines; Carbonates; Diffusion; Particles (of physics)

**Subj Catg:** 71, General and Nonclassified

7/8/233 (Item 127 from file: 32)

METADEX

(c) 2009 CSA. All rights reserved.

0001681029 IP Accession No: 200711-71-215280

**Mesoporous Titania Nanotubes: Their Preparation and Application as Electrode Materials for Rechargeable Lithium Batteries**

**Publication Date: 2007**

**Descriptors:** Titanium dioxide; Electrode materials; Lithium batteries; Energy technology ; Nanotubes

**Subj Catg:** 71, General and Nonclassified

## Appendix A-5. Irrelevant Titles

7/8/234 (Item 128 from file: 32)

METADEX

(c) 2009 CSA. All rights reserved.

0001680401 IP Accession No: 200711-71-211586

### **LAMELLAR MICELLES-MEDIATED SYNTHESIS OF NANOSCALE THICK SHEETS OF TITANIA**

**Publication Date: 2007**

**Descriptors:** Titanium dioxide; Nanostructure; Extraction; Mathematical models; Sol gel **process**; Nanomaterials; Chemical technology; Micelles; Slits; Lamellar structure; Forming; Surfactants; Orientation; Nanocrystals; Carbon dioxide; Porosity; Approximation; Surface area; Nanocomposites

**Subj Catg:** 71, General and Nonclassified

7/8/235 (Item 129 from file: 32)

METADEX

(c) 2009 CSA. All rights reserved.

0001674340 IP Accession No: 200710-34-206359

### **Photocatalytic properties of phosphor-doped titania nanoparticles**

**Publication Date: 2007**

**Descriptors:** Titanium dioxide; Photocatalysis; Surface chemistry; Anatase; Spectroscopy; X-rays; Adsorption; Surface area; Nanoparticles; X-ray photoelectron spectroscopy; Pyridines; Hydroxyl groups; Rutile; Crystallites; Phosphors; Sol gel **process**; Peking; Diffraction; Degradation; Spectra; Fourier transforms; Infrared spectroscopy; Thermal stability; Precursors; Photoelectron spectroscopy; Irradiation; Differential thermal analysis; Methylene blue; Phase transformations; Electron microscopy

**Subj Catg:** 34, Chemical and Electrochemical Properties

7/8/236 (Item 130 from file: 32)

METADEX

(c) 2009 CSA. All rights reserved.

0001670986 IP Accession No: 200710-46-208425

### **Effect of Applied Voltage on the Microstructure of Aligned Titania Nanotubes Fabricated by Anodic Oxidation Method**

**Publication Date: 2007**

**Descriptors:** Titanium dioxide; Nanotubes; Electric potential; Voltage; Electronics; Anodizing; Lithium; Microscopy; Microstructure; Electrolytes; Thin films; Annealing; Diffraction; Transmission electron microscopy; Alignment; Anatase; Heating rate; Crystals; X-rays; Scanning electron microscopy; Scanning

**Subj Catg:** 46, Nonferrous Alloy Production

7/8/237 (Item 131 from file: 32)

## Appendix A-5. Irrelevant Titles

METADEX

(c) 2009 CSA. All rights reserved.

0001668539 IP Accession No: 200709-71-187449

### **TEMPLATE SYNTHESIS OF POROUS TITANIA USING CELLULOSE NANOCRYSTALS**

**Publication Date: 2007**

**Descriptors:** Titanium dioxide; Anatase; Nanocrystals; Cellulose; Northwest; Transmission electron microscopy; Calcination; Specific surface; Hydroxyl groups; Scanning electron microscopy; Colloids; Roasting; Morphology

**Subj Catg:** 71, General and Nonclassified

7/8/238 (Item 132 from file: 32)

METADEX

(c) 2009 CSA. All rights reserved.

0001664695 IP Accession No: 200709-71-192244

### **Preparation and characterization of titanium dioxide nanocomposite fibers**

**Publication Date: 2007**

**Descriptors:** Fibers; Titanium dioxide; Nanostructure; Polypropylenes; Agglomeration; Nanomaterials; Hydrophilicity; Coating; Nanoparticles; Nanocomposites; Contact angle; Education; Scanning probe microscopy; Dynamic tests; Dynamics; Coated fibers; Irradiation; Energy dispersive; X-rays; Scanning electron microscopy

**Subj Catg:** 71, General and Nonclassified

7/8/239 (Item 133 from file: 32)

METADEX

(c) 2009 CSA. All rights reserved.

0001664544 IP Accession No: 200709-71-187401

### **PREPARATION OF COBALT-TITANIUM DIOXIDE NANOCOMPOSITE FILMS BY COMBINING INVERSE MICELLE METHOD AND PLASMA TREATMENT**

**Publication Date: 2007**

**Descriptors:** Nanostructure; Nanocomposites; Nanomaterials; Cobalt; Micelles; Thin films; Drying; Transmission electron microscopy; Equilibrium conditions; Plasma **processing**; Dioxides; Colloiding

**Subj Catg:** 71, General and Nonclassified

7/8/240 (Item 134 from file: 32)

METADEX

(c) 2009 CSA. All rights reserved.

0001660437 IP Accession No: 200709-71-192605

### **Hydrothermal preparation of nano titanium dioxide materials.**

**Publication Date: 2007**

**Descriptors:** Nanostructure; Nanocomposites; Nanomaterials; Titanium dioxide; Raw materials; Anatase; Mathematical analysis; Rutile; Diffraction; Crystal structure; Crystals; Transmission electron microscopy; X-rays; Reaction mechanisms; Pictures; Morphology

## Appendix A-5. Irrelevant Titles

**Subj Catg:** 71, General and Nonclassified

7/8/241 (Item 135 from file: 32)

METADEX

(c) 2009 CSA. All rights reserved.

0001655982 IP Accession No: 200708-61-181373

**Titanium dioxide (TiO<sub>2</sub>) nanoparticles filled poly(d,l lactid acid) (PDLA) matrix composites for bone tissue engineering**

**Publication Date: 2007**

**Descriptors:** Titanium dioxide; Nanoparticles; Nanostructure; Hydroxyapatite; Biochemistry; Bones; Biomedical materials; Magnesium; Tissue engineering; Particulate composites; Nanocrystals; Immersion; Nanomaterials; Surgical implants; Solvents; Viability; Roads; Materials selection; Biocompatibility ; Conferences; Assaying; Nanocomposites

**Subj Catg:** 61, Engineering Components and Structures

7/8/242 (Item 136 from file: 32)

METADEX

(c) 2009 CSA. All rights reserved.

0001654229 IP Accession No: 200708-71-179670

**Study on titania nanotube arrays prepared by titanium anodization in NH<sub>4</sub>F/H<sub>2</sub>SO<sub>4</sub> solution**

**Publication Date: 2007**

**Descriptors:** Titanium dioxide; Nanostructure; Nanocomposites; Nanomaterials; Arrays; Electrolytes; Anatase; Anodizing; Crystallization; Rutile; High temperature ; Titanium

**Subj Catg:** 71, General and Nonclassified

7/8/243 (Item 137 from file: 32)

METADEX

(c) 2009 CSA. All rights reserved.

0001651594 IP Accession No: 200708-71-179740

**Preparation, characterization and photocatalytic activity of TiO<sub>2</sub> / Methylcellulose nanocomposite films derived from nanopowder TiO<sub>2</sub> and modified sol-gel titania**

**Publication Date: 2007**

**Descriptors:** Nanostructure; Titanium dioxide; Nanomaterials; Nanocomposites; Scanning electron microscopy; Ethyl alcohol; Sol gel **process**; Photocatalysis; Spin coating; Thick films; Textiles; Scratch tests; Shrinkage; Titanium; Ethanol; Inhomogeneity; Glass; Crystal defects; Degradation; Catalysts; Dispersion; Deposition; Dispersants; Peeling; Mathematical models; Crystallization; Calcines; Catalysis; Surface chemistry; Fracture mechanics

**Subj Catg:** 71, General and Nonclassified

7/8/244 (Item 138 from file: 32)

METADEX

## Appendix A-5. Irrelevant Titles

(c) 2009 CSA. All rights reserved.

0001650976 IP Accession No: 200708-34-178571

### **Photocatalytic reduction of 4-nitrophenol with arginine-modified titanium dioxide nanoparticles**

**Publication Date: 2007**

**Descriptors:** Titanium dioxide; Photocatalysis; Degradation; Reduction; Byproducts; pH; Surface chemistry; Adsorption; Surface charge; Nanoparticles; Monolayers; Electrode potentials; Electrostatics; Terminals; Oxidation; Chromatography; Attraction;

**Environmental engineering;** Amines

**Subj Catg:** 34, Chemical and Electrochemical Properties

7/8/245 (Item 139 from file: 32)

METADEX

(c) 2009 CSA. All rights reserved.

0001650036 IP Accession No: 200708-34-178579

### **Nanocrystalline cobalt oxide immobilized on titanium dioxide nanoparticles for the heterogeneous activation of peroxymonosulfate**

**Publication Date: 2007**

**Descriptors:** Titanium dioxide; Activation; Cobalt; Surface chemistry; Catalysts; Nanoparticles; Hydroxyl groups; Sulfates; Titanium; Heat treatment; Leaching; Nanocrystals; Decomposition; Reduction; Remediation; Wetness; Performance evaluation; Oxidation; Catalytic activity; Impregnation; Activation **analysis**; Pathways; Pollutants; Radicals; Cobalt oxides; **Environmental engineering**

**Subj Catg:** 34, Chemical and Electrochemical Properties

7/8/246 (Item 140 from file: 32)

METADEX

(c) 2009 CSA. All rights reserved.

0001648857 IP Accession No: 200708-12-177405

### **Multistep Loading of Titania Nanoparticles in the Mesopores of SBA-15 for Enhanced Photocatalytic Activity**

**Publication Date: 2007**

**Descriptors:** Titanium dioxide; Nanoparticles; Anatase; Deposition; Photocatalysis; Sol gel process; Degradation; Channels

**Subj Catg:** 12, Crystal Properties

7/8/247 (Item 141 from file: 32)

METADEX

(c) 2009 CSA. All rights reserved.

0001640959 IP Accession No: 200707-34-158056

### **Size dependent photocatalytic activity of hydrothermally crystallized titania nanoparticles on poorly adsorbing phenol in absence and presence of fluoride ion**

## Appendix A-5. Irrelevant Titles

**Publication Date: 2007**

**Descriptors:** Titanium dioxide; Nanostructure; Phenol; Fluorides; Photocatalysis; Heat treatment; Sol gel **process**; Nanomaterials; Degradation; Catalysts; Fluorination; Crystallization; Catechol; Calcination; Crystallinity; Hydroquinone; Covering; Nanoparticles; Nanocomposites

**Subj Catg:** 34, Chemical and Electrochemical Properties

7/8/249 (Item 143 from file: 32)

METADEX

(c) 2009 CSA. All rights reserved.

0001638484 IP Accession No: 200707-12-152854

**Self-Organized Magnetic Nanowire Arrays Based on Alumina and Titania Templates**

**Publication Date: 2007**

**Descriptors:** Nanostructure; Nanocomposites; Nanomaterials; Titanium dioxide; Arrays; Order disorder; Anisotropy; Aluminum oxide; Density; Ferromagnetism; Anodizing; Magnetic properties; Magnetic storage; Electronic devices; Aspect ratio; Electrodeposition; Lattice parameters; Detection; Membranes

**Subj Catg:** 12, Crystal Properties

7/8/250 (Item 144 from file: 32)

METADEX

(c) 2009 CSA. All rights reserved.

0001638149 IP Accession No: 200707-57-168432

**Successful Application of Nanostructured Titanium Dioxide Coating for High-Pressure Acid-Leach Application**

**Publication Date: 2007**

**Descriptors:** Titanium dioxide; Nanostructure; Coating; Ball valves; Wear; Wear resistance; Hardness; Commerce; Abrasion resistance; Toughness; Abrasive erosion; Abrasive wear; Strength; Performance enhancement

**Subj Catg:** 57, Finishing

7/8/251 (Item 145 from file: 32)

METADEX

(c) 2009 CSA. All rights reserved.

0001636762 IP Accession No: 200707-34-155911

**Pure versus metal-ion-doped nanocrystalline titania for photocatalysis**

**Publication Date: 2007**

**Descriptors:** Titanium dioxide; Excitation; Photocatalysis; Dopants; Doping; Semiconductors; Anatase; Nanocrystals; Photodegradation; Dyes; Nanostructure; Rutile; Titanates; Sol gel **process**; Glass; Deposition ; Materials selection; Surfactants; Cobalt; Mixed oxides; Crystallinity; Triton; Thin films; Discoloration

**Subj Catg:** 34, Chemical and Electrochemical Properties

## Appendix A-5. Irrelevant Titles

7/8/252 (Item 146 from file: 32)

METADEX

(c) 2009 CSA. All rights reserved.

0001636428 IP Accession No: 200707-46-171749

**Preparation and characterization of nanosized titania sensing film.**

**Publication Date: 2006**

**Descriptors:** Titanium dioxide; Nanostructure; Scanning electron microscopy; Nanocomposites; Nanomaterials; Atomic force microscopy; Grain size; Detection; Dispersion; Diffraction; Surface area; X-rays; Sol gel **process**; Microstructure; Calcination; Addition polymerization; Morphology

**Subj Catg:** 46, Nonferrous Alloy Production

7/8/253 (Item 147 from file: 32)

METADEX

(c) 2009 CSA. All rights reserved.

0001636353 IP Accession No: 200707-71-155809

**Preparation of titanium dioxide nanostructures facilitated by poly-L-lysine peptide**

**Publication Date: 2007**

**Descriptors:** Nanostructure; Nanomaterials; Titanium dioxide; Scanning electron microscopy; Nanocomposites; Peptides; Nanorods; Cadmium; Combustion; Paris; Titanium; Sol gel **process**; Diffraction; Transmission electron microscopy; Calcines; Spectroscopy; Precursors; Crystal structure; X-rays

**Subj Catg:** 71, General and Nonclassified

7/8/254 (Item 148 from file: 32)

METADEX

(c) 2009 CSA. All rights reserved.

0001635178 IP Accession No: 200707-71-165021

**Photo-catalytic Activity of Fe<sup>3+</sup>/Sn<sup>4+</sup> Co-doped Titanium Dioxide Nano-crystalline Thin Films for Methyl Orange Degradation**

**Publication Date: 2007**

**Descriptors:** Nanocrystals; Titanium dioxide; Oranges; Thin films; Degradation; Mathematical models; Surface chemistry; Atomic force microscopy; Dip coatings; Doping; Sol gel **process**; Glass; Diffraction; Morphology; Iron; Mercury lamps; Cobalt; Synergistic effect; Atomic structure; Irradiation; X-rays; Tin; Spectrophotometers

**Subj Catg:** 71, General and Nonclassified

7/8/255 (Item 149 from file: 32)

METADEX

(c) 2009 CSA. All rights reserved.

0001633709 IP Accession No: 200707-71-155422

**Nanostructured titania/hydroxyapatite composite coatings deposited by high velocity**

## Appendix A-5. Irrelevant Titles

### **oxy-fuel (HVOF) spraying**

**Publication Date: 2007**

**Descriptors:** Titanium dioxide; Hydroxyapatite; Nanostructure; Coating; Spraying; Bonding strength; Flame spraying; Surgical implants; Blends; Microstructure; Particulate composites; Biocompatibility; Feedstock; Oxy-fuel; Roughness; Polymer blends; Diamond pyramid hardness; Protective coatings; Diffraction patterns; Deposition; Corrosion resistance; Titanium base alloys; Sprayed coatings; Composite coatings; Particle size distribution; Chemical reactions; Hardness; X-rays; Porosity; Vickers hardness

**Subj Catg:** 71, General and Nonclassified

7/8/256 (Item 150 from file: 32)

METADEX

(c) 2009 CSA. All rights reserved.

0001632894 IP Accession No: 200707-71-164099

### **ENHANCED PHOTOACTIVITY AND ANATASE THERMAL STABILITY OF SILICA-ALUMINA MIXED OXIDE ADDITIVES ON SOL-GEL NANOCRYSTALLINE TITANIA**

**Publication Date: 2007**

**Descriptors:** Titanium dioxide; Mixed oxides; Anatase; Specific surface; Rutile; Sol gel process; Nanocrystals; Silicon dioxide; Sulfates; Phase stability; Transformations; Degradation; Calcination; Thermal stability; Precursors; Photocatalysis; Methylene blue; Phase transformations; Surface area

**Subj Catg:** 71, General and Nonclassified

7/8/257 (Item 151 from file: 32)

METADEX

(c) 2009 CSA. All rights reserved.

0001632592 IP Accession No: 200707-71-159029

### **Influence of process parameters on the synthesis of nano- titania by sol-gel route**

**Publication Date: 2007**

**Descriptors:** Nanostructure; Sol gel process; Nanomaterials; Catalysts; Crystallization; Nanocomposites; Transformation temperature; Rutile; Metallurgy; Heating; Ethyl alcohol; Moisture content; Titanium; Process parameters; Acetylacetone; Solvents; Anatase; Calcination; Precursors; Materials engineering

**Subj Catg:** 71, General and Nonclassified

7/8/258 (Item 152 from file: 32)

METADEX

(c) 2009 CSA. All rights reserved.

0001632556 IP Accession No: 200707-61-169106

### **Influence of engineered titania nanotubular surfaces on bone cells**

**Publication Date: 2007**

**Descriptors:** Titanium dioxide; Nanostructure; Nanomaterials; Nanocomposites; Surgical implants; Biocompatibility; Surface chemistry; Bones; Analysis of variance; Biomedical

## Appendix A-5. Irrelevant Titles

materials; Anodizing; Orthopedics; Males; Physiology; Bioengineering; Acceleration; Adhesion; Titanium; In vitro testing; Biomaterials; Culture; Deposition; Wound healing; Biomechanics; Differentiation; In vivo tests; Platforms; In vivo testing; Design engineering; Rats

**Subj Catg:** 61, Engineering Components and Structures

7/8/259 (Item 153 from file: 32)

METADEX

(c) 2009 CSA. All rights reserved.

0001632234 IP Accession No: 200707-63-172345

### **NIOBIUM-DOPED TITANIA NANOPOWDERS FOR GAS SENSOR APPLICATIONS**

**Publication Date:** 2005

**Descriptors:** Titanium dioxide; Nanostructure; Nanocomposites; Nanomaterials; Physical properties; Precursors; Electronic engineering; Sol gel **process**; Gas sensors; Alkoxides; Niobium; Detection; Scanning electron microscopy; Roasting

**Subj Catg:** 63, Electronic Devices

7/8/260 (Item 154 from file: 32)

METADEX

(c) 2009 CSA. All rights reserved.

0001628252 IP Accession No: 200707-57-155601

### **Fatigue and mechanical properties of nanostructured and conventional titania (TiO<sub>2</sub>) thermal spray coatings**

**Publication Date:** 2007

**Descriptors:** Titanium dioxide; Coatings; Nanostructure; Scanning electron microscopy; Fatigue (materials); Fatigue strength; Mechanical properties; Fracture mechanics; Fracture surfaces; Flame spraying; Fatigue failure; Crack initiation; Spray coating; Deposition; Low carbon steels; Air plasma; Amplitudes; Microstructure; Deformation mechanisms; Strain; Vickers indentation; Hardness; Oxy-fuel; Deformation; Spraying; Halls; Crack propagation

**Subj Catg:** 57, Finishing

7/8/261 (Item 155 from file: 32)

METADEX

(c) 2009 CSA. All rights reserved.

0001626508 IP Accession No: 200707-71-165038

### **Effect of Drying Methods on Photocatalytic Activity of Nanosized Titanium Dioxide**

**Publication Date:** 2007

**Descriptors:** Titanium dioxide; Drying; Nanostructure; Photocatalysis; Infrared; Nanocomposites; Nanomaterials; Heat treatment; Crystal structure; Precursors; Hydrolysis; Alkoxides; Phase composition

**Subj Catg:** 71, General and Nonclassified

## Appendix A-5. Irrelevant Titles

7/8/262 (Item 156 from file: 32)

METADEX

(c) 2009 CSA. All rights reserved.

0001626103 IP Accession No: 200707-12-152895

**Dye-Sensitized Solar Cells Based on Nanocrystalline Titania Electrodes Made at Various Sintering Temperatures**

**Publication Date: 2007**

**Descriptors:** Titanium dioxide; Electrodes; Solar cells; Sintering; Nanocrystals; Photovoltaic cells; Nanostructure; Deposition; Dyes; Electric potential; Adhesion; Sodium salts; Sol gel **process**; Nanomaterials; Distilled water; Tin dioxide; Cyclohexane; Voltage; Surfactants; Reverse micelles; Tin oxides; Rinsing; Short circuit currents; Nanocomposites

**Subj Catg:** 12, Crystal Properties

7/8/263 (Item 157 from file: 32)

METADEX

(c) 2009 CSA. All rights reserved.

0001619996 IP Accession No: 200706-71-138165

**Biodegradable polyester hybrid nanocomposites containing titanium dioxide network and poly(epsilon-caprolactone): Synthesis and characterization**

**Publication Date: 2007**

**Descriptors:** Titanium dioxide; Crystallization; Biodegradability; Differential scanning calorimetry; X-rays; X-ray photoelectron spectroscopy; Electronics; Lithium ; Titanates; Networks; Sol gel **process**; Diffraction; Polyester resins; Tetrabutyls; Microscopy; Fourier transforms; Infrared spectroscopy; Melting; Precursors; Photoelectron spectroscopy; Scanning electron microscopy; **Environmental** engineering; Nanocomposites; Scanning

**Subj Catg:** 71, General and Nonclassified

7/8/265 (Item 159 from file: 32)

METADEX

(c) 2009 CSA. All rights reserved.

0001616446 IP Accession No: 200705-71-135298

**Antimicrobial activity of composite nanoparticles consisting of titania photocatalytic shell and nickel ferrite magnetic core**

**Publication Date: 2007**

**Descriptors:** Titanium dioxide; Bacteria; Photocatalysis; Nanoparticles; Nickel ferrites; Magnetic cores; Particulate composites; Anatase; Superparamagnetism; Inactivation; Magnetic measurement; Photocatalysts; Remanence; Magnetic moment; Reverse micelles; Superconducting quantum interference devices; Hysteresis; SQUIDS; Nanocrystals; Particle size; Hydrolysis

**Subj Catg:** 71, General and Nonclassified

## Appendix A-5. Irrelevant Titles

7/8/267 (Item 161 from file: 32)

METADEX

(c) 2009 CSA. All rights reserved.

0001600327 IP Accession No: 200703-71-043719

**Polymer microspheres stabilized by titania nanoparticles.**

**Publication Date: 2006**

**Descriptors:** Titanium dioxide; Nanostructure; Nanoparticles; Nanocomposites; Nanomaterials; Microspheres; Emulsions; Polytechnics; Microstructure; Nanotechnology; Emulsifiers; Forming; Air purification; Protuberances; Emulsion polymerization

**Subj Catg:** 71, General and Nonclassified

7/8/268 (Item 162 from file: 32)

METADEX

(c) 2009 CSA. All rights reserved.

0001600326 IP Accession No: 200703-71-038535

**POLYMER MICROSPHERES STABILISED BY TITANIA NANOPARTICLES**

**Publication Date: 2006**

**Descriptors:** Titanium dioxide; Nanostructure; Nanoparticles; Nanocomposites; Nanomaterials; Emulsions; Microspheres; Polytechnics; Microstructure; Emulsifiers; Forming; Air purification; Polymerization; Protuberances

**Subj Catg:** 71, General and Nonclassified

7/8/269 (Item 163 from file: 32)

METADEX

(c) 2009 CSA. All rights reserved.

0001600128 IP Accession No: 200703-34-048651

**Photoelectrochemical application of nanotubular titania photoanode**

**Publication Date: 2006**

**Descriptors:** Titanium dioxide; Nanostructure; Titanium; Electrodes; Nanomaterials; Nanocomposites; Electrolytes; Arrays; Field emission; Anodizing; Hafnium; Photoelectric effect; Photocurrent; Diffraction; Degradation; Voltammetry; Surface structure; Crystallization; Nanotubes; Crystals; Photocatalysis; X-rays; Pollutants; Scanning electron microscopy; Foils (structural shapes)

**Subj Catg:** 34, Chemical and Electrochemical Properties

7/8/270 (Item 164 from file: 32)

METADEX

(c) 2009 CSA. All rights reserved.

0001599623 IP Accession No: 200703-32-049637

**Investigation on mechanism of photocatalytic activity enhancement of nanometer cerium-doped titania**

## Appendix A-5. Irrelevant Titles

**Publication Date: 2006**

**Descriptors:** Titanium dioxide; Reflectance; Cerium; Cerium oxide; Photocatalysis; Valence; X-ray photoelectron spectroscopy; Reflectivity; Trapping; Doppler effect; Titanium; Sol gel **process**; Raw materials; Transmission electron microscopy; Degradation; Agricultural chemicals; Aberration; Planes; Agronomy; Calcination; Retarding; Nitrates; Red shift; Formaldehyde

**Subj Catg:** 32, Physical Properties

7/8/271 (Item 165 from file: 32)

METADEX

(c) 2009 CSA. All rights reserved.

0001598070 IP Accession No: 200703-71-043680

**Enhanced photoelectrochemical current response of titania nanotube array.**

**Publication Date: 2006**

**Descriptors:** Titanium dioxide; Nanostructure; Nanocomposites; Nanomaterials; Titanium; Electrodes; Arrays; Anodizing; Electrolytes; Foils (structural shapes); Polytechnics; Crystallization; Microstructure; Lithium; Mechanical engineering; Oxidation; Morphology

**Subj Catg:** 71, General and Nonclassified

7/8/272 (Item 166 from file: 32)

METADEX

(c) 2009 CSA. All rights reserved.

0001597013 IP Accession No: 200703-23-055427

**Amperometric nitrite sensor based on hemoglobin/colloidal gold nanoparticles immobilized on a glassy carbon electrode by a titania sol-gel film**

**Publication Date: 2005**

**Descriptors:** Titanium dioxide; Sensors; Nitrites; Sol gel **process**; pH; Gold; Colloids; Nanoparticles; Electrodes; Glassy carbon; Hemoglobin; Reduction; Electrical measurements; Lithium; Silver; Phosphates; Separation; Sun; Electron transfer; Immobilization; Transportation; Selectivity; Buffer solutions; Republic of China; Joining; Reproducibility; Repeatability

**Subj Catg:** 23, Analysis

7/8/273 (Item 167 from file: 32)

METADEX

(c) 2009 CSA. All rights reserved.

0001596241 IP Accession No: 200703-71-044636

**Microstructure effect of nanocrystalline titanium dioxide prepared by microemulsion technique on photocatalytic decomposition of phenol.**

**Publication Date: 2006**

**Descriptors:** Titanium dioxide; Microemulsions; Phenol; Photocatalysis; Microstructure; Precipitation; Decomposition; Sodium; Titanium; Crude oil; Morphology; Degradation; Surfactants; Surface chemistry; Crystals; Nanocrystals; **Exposure**; Nanoparticles; Bangkok

## Appendix A-5. Irrelevant Titles

**Subj Catg:** 71, General and Nonclassified

7/8/274 (Item 168 from file: 32)

METADEX

(c) 2009 CSA. All rights reserved.

0001594231 IP Accession No: 200703-71-039857

**Aggregation Behavior and the Resulting Morphology of Nanocrystalline Titania in Peptization and Hydrothermal Process**

**Publication Date: 2007**

**Descriptors:** Titanium dioxide; Colloiding; Scanning electron microscopy; Agglomeration; Crystallization; Crystal structure; Morphology; Anatase; Nanocrystals; Grains; Nanoparticles; Rutile; Lithium; Light scattering; Diffraction; Dynamic tests; Dynamics; X-rays

**Subj Catg:** 71, General and Nonclassified

7/8/275 (Item 169 from file: 32)

METADEX

(c) 2009 CSA. All rights reserved.

0001593056 IP Accession No: 200703-34-050729

**Effect of microemulsion composition on textural and photocatalytic activity of titania nanomaterial**

**Publication Date: 2006**

**Descriptors:** Titanium dioxide; Nanostructure; Photocatalysis; Microemulsions; Reduction; Nanomaterials; Catalysts; Hexavalent chromium; Decomposition; Nanocomposites; Sunlight; Rutile; Crystallites; Moisture content; Correlation; Transmission electron microscopy; Cyclohexane; Anatase; pH; Particle size; Colloids; Surface area; Composition effects

**Subj Catg:** 34, Chemical and Electrochemical Properties

7/8/276 (Item 170 from file: 32)

METADEX

(c) 2009 CSA. All rights reserved.

0001592717 IP Accession No: 200703-71-044779

**Fabrication and I-V characteristics of nanocrystalline titania electrode sensitized by zinc phthalocyanine.**

**Publication Date: 2006**

**Descriptors:** Titanium dioxide; Zinc; Electrodes; Density; Photoelectric effect; Photocurrent; Photovoltages; Lauric acid; Lithium; Solar simulators; Profilometers; Sol gel **process**; Deposition; Sun; Oxides; Conduction; Autoclaving; Chemical engineering; Nanocrystals; Scanning electron microscopy; Colloids; Atomic force microscopy

**Subj Catg:** 71, General and Nonclassified

7/8/277 (Item 171 from file: 32)

## Appendix A-5. Irrelevant Titles

METADEX

(c) 2009 CSA. All rights reserved.

0001588151 IP Accession No: 200702-71-030864

**Two-dimensional, open-pored, mesoscopic titania layers using polymeric nanoparticle monolayers as a template.**

**Publication Date: 2004**

**Descriptors:** Titanium dioxide; Nanostructure; Nanocomposites; Nanomaterials; Two dimensional; Monolayers; Toluene; Iodides; Porosity; Sol gel **process** ; Pore size; Dissolution

**Subj Catg:** 71, General and Nonclassified

7/8/278 (Item 172 from file: 32)

METADEX

(c) 2009 CSA. All rights reserved.

0001588113 IP Accession No: 200702-34-037184

**Titanium dioxide nanotube arrays fabricated by anodizing processes. Electrochemical properties.**

**Publication Date: 2006**

**Descriptors:** Nanostructure; Nanomaterials; Nanocomposites; Anodizing; Arrays; Titanium dioxide; Titanium; Electric potential; Architecture; Hole size; Morphology; Deposition; Separation; Anodizing baths; Voltage; Chemical engineering; United States; Intercalation; Orientation; Corrosion

**Subj Catg:** 34, Chemical and Electrochemical Properties

7/8/279 (Item 173 from file: 32)

METADEX

(c) 2009 CSA. All rights reserved.

0001586107 IP Accession No: 200702-71-036990

**Synthesis, processing and characterization of nanocrystalline titanium dioxide.**

**Publication Date: 2006**

**Descriptors:** Titanium dioxide; Sintering; Nanostructure; Nanocrystals; Density; Compressive strength; Compacting; Thermal properties; Crystallites; Sol gel **process**; Nanomaterials; Diffraction; Morphology; Transmission electron microscopy; Isopropanol; Aerospace engineering; Titanium base alloys; Deionization; Anatase; Mechanical properties; Calcination; Hardness ; Differential scanning calorimetry; X-rays; Lattices; Nanocomposites; Densification

**Subj Catg:** 71, General and Nonclassified

7/8/280 (Item 174 from file: 32)

METADEX

(c) 2009 CSA. All rights reserved.

0001586083 IP Accession No: 200702-71-019867

## Appendix A-5. Irrelevant Titles

**Synthesis and optical absorption property of ordered macroporous titania film doped with Ag nanoparticles.**

**Publication Date: 2006**

**Descriptors:** Titanium dioxide; Silver; Nanostructure; Nanomaterials; Anatase; Nanoparticles; Interstitials; Doping; Polystyrene resins; Sol gel **process**; Voids; Sun; Plasma resonance; Solid state physics; Catalysis; Gas sensors; Silver nitrates; Atmospheres; Properties; Colloids; Nanocomposites

**Subj Catg:** 71, General and Nonclassified

7/8/281 (Item 175 from file: 32)

METADEX

(c) 2009 CSA. All rights reserved.

0001585952 IP Accession No: 200702-12-032916

**Synthesis of Titanium Dioxide (TiO<sub>2</sub>) nanomaterials.**

**Publication Date: 2006**

**Descriptors:** Titanium dioxide; Nanomaterials; Nanostructure; Nanowires; Nanorods; Quantum confinement; Nanocomposites; Nanoparticles; Vapor deposition; Extreme values; Sol gel **process**; United States; Energy technology; Carriers; Nanotubes; Mechanical engineering; Environmental law

**Subj Catg:** 12, Crystal Properties

7/8/282 (Item 176 from file: 32)

METADEX

(c) 2009 CSA. All rights reserved.

0001584213 IP Accession No: 200702-71-034911

**Sono-and photochemical routes for the formation of highly dispersed gold nanoclusters in mesoporous titania films.**

**Publication Date: 2004**

**Descriptors:** Titanium dioxide; Nanostructure; Gold; Nanoparticles; Dispersion; Precursors; Gold chloride; Reduction; Nanomaterials; Tungsten; Stabilization; Catalysts; C (programming language); Photochemical; Aggregates; Photocatalysis; Porosity; Ligands; Nanocomposites

**Subj Catg:** 71, General and Nonclassified

7/8/283 (Item 177 from file: 32)

METADEX

(c) 2009 CSA. All rights reserved.

0001578166 IP Accession No: 200702-71-030537

**Neodymium ion dopant effects on the phase transformation in sol-gel derived titania nanostructures.**

**Publication Date: 2004**

**Descriptors:** Titanium dioxide; Nanostructure; Dopants; Anatase; Phase transformations; Rutile; Doping; Sol gel **process**; Distortion; Spectroscopy; X-rays; Neodymium; Lithium; Accommodation; Interstitials; Burns; Nanomaterials; Diffraction; Spectrometry; United

## Appendix A-5. Irrelevant Titles

States; Structural analysis; Activation energy; Energy dispersive; Lattices; Thermodynamics; Scanning electron microscopy; Halls; Nanocomposites

**Subj Catg:** 71, General and Nonclassified

7/8/284 (Item 178 from file: 32)

METADEX

(c) 2009 CSA. All rights reserved.

0001577640 IP Accession No: 200702-71-032654

**Morphology tuning in nontemplated solvothermal synthesis of titania nanoparticles.**

**Publication Date:** 2006

**Descriptors:** Titanium dioxide; Morphology; Tuning; Nanoparticles; Ethyl alcohol; Nanocrystals; Manchester; Crystal growth; Anatase; Nucleation; Crystallites ; Ethanol; Isopropanol; Acicular structure; Reaction mechanisms

**Subj Catg:** 71, General and Nonclassified

7/8/286 (Item 180 from file: 32)

METADEX

(c) 2009 CSA. All rights reserved.

0001575730 IP Accession No: 200702-71-030015

**Ligand-directed assembly of preformed titania nanocrystals into highly anisotropic nanostructures.**

**Publication Date:** 2004

**Descriptors:** Nanostructure; Titanium dioxide; Self assembly; Nanomaterials; Assembly; Nanoparticles; Nanocomposites; Anisotropy; Nanotechnology; Surface properties; Superstructures; Strategy; Crystal structure; Nanocrystals; Particle size; Positioning; Colloids; Control surfaces

**Subj Catg:** 71, General and Nonclassified

7/8/288 (Item 182 from file: 32)

METADEX

(c) 2009 CSA. All rights reserved.

0001567914 IP Accession No: 200701-71-015166

**Titania nanocrystals-dispersed coatings from SiO<sub>2</sub>-TiO<sub>2</sub> gel films through hydrolysis and dissolution.**

**Publication Date:** 2006

**Descriptors:** Titanium dioxide; Silicon dioxide; Nanocrystals; Nanostructure; Coatings; Anatase; Dissolution; Hot water; Hydrolysis; Water vapor; Vibration; Nucleation; Habits; Sol gel **process**; Nanomaterials; Morphology; Crystals; Photocatalysis; Nanocomposites; Migration

**Subj Catg:** 71, General and Nonclassified

7/8/289 (Item 183 from file: 32)

## Appendix A-5. Irrelevant Titles

METADEX

(c) 2009 CSA. All rights reserved.

0001566285 IP Accession No: 200701-71-015093

**Synthesis and properties of titania nanotube doped with small amount of cations.**

**Publication Date: 2006**

**Descriptors:** Titanium dioxide; Nanostructure; Nanocomposites; Nanomaterials; Manganese; Chromium; Cations; Spectra; Color; Electrical properties; Electrical resistivity; Dopants; Properties; Niobium; Absorption spectra; Morphology

**Subj Catg:** 71, General and Nonclassified

7/8/290 (Item 184 from file: 32)

METADEX

(c) 2009 CSA. All rights reserved.

0001566215 IP Accession No: 200701-58-007934

**Synthesis and characteristics of polyimide/titania nano hybrid films**

**Publication Date: 2006**

**Descriptors:** Titanium dioxide; Nanostructure; Polyimide resins; Nanomaterials; Images; Nanocomposites; Dynamical systems; Metallurgy; Ethers; Weight loss; Crosslinking; Sol gel **process;** Chains; Electron microscopes; Transmission electron microscopy; Coatings; Thermal decomposition; Thermal analysis; Dynamic tests; Flexibility; Dynamics; Phthalic anhydride; Thin films; Chelating; Materials engineering; Conferences; Particle size; Refractivity; Refractive index; Glass transition temperature

**Subj Catg:** 58, Metallic Coating

7/8/291 (Item 185 from file: 32)

METADEX

(c) 2009 CSA. All rights reserved.

0001564983 IP Accession No: 200701-12-016335

**Spiral growth of one dimensional titania nanostructures using anodic oxidation.**

**Publication Date: 2006**

**Descriptors:** Titanium dioxide; Nanostructure; Images; Spirals; Nanomaterials; Atomic force microscopy; Nanocomposites; Anodizing; Current density; Field emission; Anisotropy; Nanotechnology; Seals; Aerospace engineering; Fluorides; Titanium base alloys; Tubes; Materials **processing;** Nanotubes; High resolution; United States; Scanning electron microscopy; Electron micrographs; Phosphoric acid

**Subj Catg:** 12, Crystal Properties

7/8/292 (Item 186 from file: 32)

METADEX

(c) 2009 CSA. All rights reserved.

0001564916 IP Accession No: 200701-71-006495

**Spectroscopic investigation of the composition of electrospun titania nanofibers.**

**Publication Date: 2006**

**Descriptors:** Titanium dioxide; Electrospinning; Spectroscopy; Nanofibers; Molecular

## Appendix A-5. Irrelevant Titles

structure; X-ray photoelectron spectroscopy; Pyrolysis; Bending machines; Clathrates; Fourier transforms; Silicones; United States; Photoelectron spectroscopy; Impurities; Syringes; Pumps; X-rays; Carbon dioxide; Infrared ; Silicon  
**Subj Catg:** 71, General and Nonclassified

7/8/293 (Item 187 from file: 32)

METADEX

(c) 2009 CSA. All rights reserved.

0001560744 IP Accession No: 200701-12-013032

**One step process for chemical vapour deposition of titanium dioxide thin films incorporating controlled structure nanoparticles**

**Publication Date: 2006**

**Descriptors:** Nanostructure; Mathematical models; Titanium dioxide; Thin films; Nanoparticles; Chemical vapor deposition; Nanomaterials; Glass; Nanocomposites; Diffraction; Atmospheric pressure; UK; Diffusion; Reactors; Thermophoresis; Particle size distribution; Barometric pressure; Photocatalysis; Crystallinity; X-rays; Decomposition; Stearic acid; Scanning electron microscopy; Conversion

**Subj Catg:** 12, Crystal Properties

7/8/294 (Item 188 from file: 32)

METADEX

(c) 2009 CSA. All rights reserved.

0001558827 IP Accession No: 200701-71-011778

**Immobilization and photocatalytic efficiency of titania nanoparticles on silica carrier spheres.**

**Publication Date: 2006**

**Descriptors:** Titanium dioxide; Photocatalysis; Catalysts; Nanoparticles; Nanostructure; Silicon dioxide; Immobilization; Carriers; Chemical engineering; Nanocomposites; Nanomaterials; Surface area; Diffusion; Methylene blue; Republic of China; Catalysis

**Subj Catg:** 71, General and Nonclassified

7/8/295 (Item 189 from file: 32)

METADEX

(c) 2009 CSA. All rights reserved.

0001555287 IP Accession No: 200701-71-011684

**Effects of postthermal treatment and UV irradiation on the structure of titania-polyacrylate nanocomposites.**

**Publication Date: 2006**

**Descriptors:** Titanium dioxide; Irradiation; Atomic force microscopy; Nanocomposites; X-ray photoelectron spectroscopy; Sol gel **process**; Gravimetry; Photopolymerization; Reverse micelles; Colleges; Prolongation; Wide area networks; Thermal stability; Atomic structure; Photoelectrons; Polyacrylates; X-rays; Decomposition; Materials engineering

## Appendix A-5. Irrelevant Titles

**Subj Catg:** 71, General and Nonclassified

7/8/296 (Item 190 from file: 32)

METADEX

(c) 2009 CSA. All rights reserved.

0001549555 IP Accession No: 200612-61-62413

**The Effect of Substrates on the Characteristics of Titania Nano-Coated Particles Prepared by Fluidized Bed Chemical Vapor Deposition (FBCVD)**

**Publication Date: 2006**

**Descriptors:** Titanium dioxide; Nanostructure; Photocatalysis; Beads; Volatile organic compounds; Carbon dioxide; Chemical vapor deposition; Fluidized beds; Nanocomposites; Nanomaterials; Oxidation; Acetaldehyde; Degradation; Photocatalysts; Painting; X-ray photoelectron spectroscopy; Air pollution; Catalysts; Paints; Protective coatings

**Subj Catg:** 61, Engineering Components and Structures

7/8/297 (Item 191 from file: 32)

METADEX

(c) 2009 CSA. All rights reserved.

0001549186 IP Accession No: 200612-12-53225

**Synthesis of TiO<sub>2</sub> Au Composites by Titania-Nanorod Assisted Generation of Gold Nanoparticles at Aqueous/Nonpolar Interfaces**

**Publication Date: 2006**

**Descriptors:** Gold; Titanium dioxide; Nanostructure; Nanoparticles; Nanorods; Generation; Catalysis; Hybrid systems; Synthesis; Tools; Anatase; Colloiding; Interfacial energy; Modulation; Solvents; Reduction; Nucleation; Nanocomposites; Ligands; Access

**Subj Catg:** 12, Crystal Properties

7/8/298 (Item 192 from file: 32)

METADEX

(c) 2009 CSA. All rights reserved.

0001547889 IP Accession No: 200612-12-53297

**Sol-gel growth of titania from electrospun polyacrylonitrile nanofibres**

**Publication Date: 2006**

**Descriptors:** Nanostructure; Titanium dioxide; Nanocomposites; Nanomaterials; Electrospinning; Precursors; Sol gel **process**; Polyacrylonitriles; Density; Spark plasma sintering; Photovoltages; Anatase; Stability; Pattern **analysis**; Catalysis; Nanotechnology; Hydrolysis; Transmission electron microscopy; Indium tin oxide; Water pollution

**Subj Catg:** 12, Crystal Properties

7/8/299 (Item 193 from file: 32)

METADEX

(c) 2009 CSA. All rights reserved.

## Appendix A-5. Irrelevant Titles

0001547280 IP Accession No: 200612-61-62404

### **Raman Spectroscopic Investigation of Nitrogen-doped Titanium dioxide Nanoparticles**

**Publication Date: 2006**

**Descriptors:** Titanium dioxide; Nanoparticles; X-ray photoelectron spectroscopy; Materials science; Peaks; Raman spectroscopy; Microstructure; Sol gel **process**; Annealing; Red shift; Absorption spectra; Doppler effect; Spectroscopy

**Subj Catg:** 61, Engineering Components and Structures

7/8/300 (Item 194 from file: 32)

METADEX

(c) 2009 CSA. All rights reserved.

0001546773 IP Accession No: 200612-32-55572

### **Optical properties of in situ doped and undoped titania nanocatalysts and doped titania sol-gel nanofilms**

**Publication Date: 2006**

**Descriptors:** Titanium dioxide; Nanostructure; Sol gel **process**; Mathematical analysis; Nanocomposites; Nanomaterials; Density; Optical properties; Rhodamine 6G; Absorption spectra; Excitation; Quenching; Rutile; Spectroscopic analysis; Approximation; Band structure of solids; Thin films ; Band spectra; Electronics; Emission

**Subj Catg:** 32, Physical Properties

7/8/301 (Item 195 from file: 32)

METADEX

(c) 2009 CSA. All rights reserved.

0001545716 IP Accession No: 200612-34-57634

### **New Experimental Routes to Prepare Titania Foam and Thiol-functionalized Nanoporous Titania-silica**

**Publication Date: 2005**

**Descriptors:** Titanium dioxide; Nanostructure; Sol gel **process**; Foams; Synthesis; Anatase; Porosity; Nanocomposites; Thiols; Joints; Photocatalysis; Nanomaterials; Surface area; Dissolution; Crystal structure; Silicon dioxide; Mercury; Activated carbon; Silicon; Titanium

**Subj Catg:** 34, Chemical and Electrochemical Properties

7/8/302 (Item 196 from file: 32)

METADEX

(c) 2009 CSA. All rights reserved.

0001545171 IP Accession No: 200612-61-63430

### **Antimicrobial function of Nd<sup>3+</sup>-doped anatase titania-coated nickel ferrite composite nanoparticles: A biomaterial system**

**Publication Date: 2006**

**Descriptors:** Titanium dioxide; Nanoparticles; Particulate composites; Ferrite; Photocatalysis; Shells; Nickel ferrites; Magnetic fields; Synthesis; Anatase; Methodology; Neodymium; Viability; Hydrolysis; Movement; Energy gap; Biomedical materials; Coating; Reverse micelles; Strength

## Appendix A-5. Irrelevant Titles

**Subj Catg:** 61, Engineering Components and Structures

7/8/303 (Item 197 from file: 32)

METADEX

(c) 2009 CSA. All rights reserved.

0001544786 IP Accession No: 200612-34-56476

**Nanopatterning of photonic crystals with a photocurable silica- titania organic-inorganic hybrid material by a UV-based nanoimprint technique**

**Publication Date: 2005**

**Descriptors:** Nanostructure; Nanocomposites; Nanomaterials; Photonic crystals; Sol-gel; Refractivity; Refractive index; Silicon; Low pressure; Shrinkage; Industrial engineering; Networks; Replication; Fabrication; Alkoxides; **Manufacturing** engineering

**Subj Catg:** 34, Chemical and Electrochemical Properties

7/8/304 (Item 198 from file: 32)

METADEX

(c) 2009 CSA. All rights reserved.

0001538862 IP Accession No: 200612-34-57545

**Controlled growth of titania nanospheres in supercritical carbon dioxide using a novel surfactant stabilised precursor**

**Publication Date: 2006**

**Descriptors:** Titanium dioxide; Carbon dioxide; Precursors; Nanospheres; Particle size distribution; Solvents; Hydrolysis; Titanium; Surfactants

**Subj Catg:** 34, Chemical and Electrochemical Properties

7/8/305 (Item 199 from file: 32)

METADEX

(c) 2009 CSA. All rights reserved.

0001535815 IP Accession No: 200611-32-49624

**Dynamic nucleation and growth of Ni nanoparticles on high-surface area titania**

**Publication Date: 2006**

**Descriptors:** Titanium dioxide; Nickel; Rutile; Nanoparticles; Anatase; Nucleation; Morphology; Clusters; Wetness; Dynamic tests; Interfacial energy; Catalysis ; Electron microscopes; Precursors; Wetting; Catalysts

**Subj Catg:** 32, Physical Properties

7/8/306 (Item 200 from file: 32)

METADEX

(c) 2009 CSA. All rights reserved.

0001529923 IP Accession No: 200610-42-46165

**Nanostructured Titania Coated Titanium.**

**Publication Date: 2005**

## Appendix A-5. Irrelevant Titles

**Descriptors:** Patents; Titanium dioxide; Titanium; Nanostructured materials; Ball valves; Acid leaching; Nickel ores; Corrosion resistance; Protective coatings

**Subj Catg:** 42, Extraction and Smelting

7/8/307 (Item 201 from file: 32)

METADEX

(c) 2009 CSA. All rights reserved.

0001529811 IP Accession No: 200610-33-45772

**Nanocomposite titanium dioxide/polymer photovoltaic cells: effects of TiO<sub>2</sub> microstructure, time, and illumination power**

**Publication Date: 2003**

**Descriptors:** Titanium dioxide; Illumination; Photovoltaic cells; Equivalent circuits; Sol gel process; Nanocomposites; Crystal structure; Dark current; Microstructure; Shunt resistance; Gold; Trapped charge; Indium tin oxide

**Subj Catg:** 33, Electrical and Magnetic Phenomena

7/8/308 (Item 202 from file: 32)

METADEX

(c) 2009 CSA. All rights reserved.

0001521588 IP Accession No: 200609-34-33644

**Photoelectrochemical Properties of Highly-ordered Titania Nanotube-arrays**

**Publication Date: 2005**

**Descriptors:** Titanium dioxide; Nanostructure; Nanocomposites; Nanomaterials; Hydrogen storage; Illumination; Porosity; Charge transport; Computational efficiency ; Photoelectrolysis; Quantum efficiency; Mathematical analysis

**Subj Catg:** 34, Chemical and Electrochemical Properties

7/8/309 (Item 203 from file: 32)

METADEX

(c) 2009 CSA. All rights reserved.

0001520418 IP Accession No: 200609-57-35554

**From APS to HVOF spraying of conventional and nanostructured titania feedstock powders: a study on the enhancement of the mechanical properties**

**Publication Date: 2006**

**Descriptors:** Titanium dioxide; High velocity oxyfuel spraying; Plasma spraying; Low carbon steels; Nanostructured materials; Crack propagation; Abrasion resistance; Vickers indentation; Bonding strength; Crack tips; Abrasion resistant coatings; Agglomeration; Microstructure

**Subj Catg:** 57, Finishing

7/8/310 (Item 204 from file: 32)

METADEX

## Appendix A-5. Irrelevant Titles

(c) 2009 CSA. All rights reserved.

0001504629 IP Accession No: 200605-57-18435

**Electrophoresis coating of titanium dioxide nanoparticles in anodic nanotemplate**

**Publication Date: 2005**

**Descriptors:** Nanoparticles; Titanium oxides; Aluminum; Electrophoresis; Anodic coatings; Titanium dioxide; Templates; Nanomaterials; Oxide coatings

**Subj Catg:** 57, Finishing

7/8/311 (Item 205 from file: 32)

METADEX

(c) 2009 CSA. All rights reserved.

0001498592 IP Accession No: 200603-61-09849

**Vibrational Spectroscopic Studies on the Formation of Ion-exchangeable Titania**

**Nanotubes**

**Publication Date: 2005**

**Descriptors:** Titanium dioxide; Nanotubes; Nanostructure; Images; Transmission electron microscopy; Materials science; Spectroscopic analysis; Spirals; High resolution; Nanocomposites; Nanoparticles; Multi wall carbon nanotubes; Electronic properties; Coaxial; Cadmium sulfides; Doping

**Subj Catg:** 61, Engineering Components and Structures

7/8/312 (Item 206 from file: 32)

METADEX

(c) 2009 CSA. All rights reserved.

0001497562 IP Accession No: 200603-34-07589

**Preparation of noble metal nanoparticles \* titania precursor composite electrostatic self--assembled film**

**Publication Date: 2006**

**Descriptors:** Titanium dioxide; Precursors; Gold; Palladium; Platinum; Nanoparticles; Catalysis; Ion exchangers; Self assembly; Thin films

**Subj Catg:** 34, Chemical and Electrochemical Properties

7/8/313 (Item 207 from file: 32)

METADEX

(c) 2009 CSA. All rights reserved.

0001494013 IP Accession No: 200602-57-05634

**Preparation of Plasma Sprayed Titania/Hydroxyapatite Photocatalytic Coatings with Nanostructured Powder**

**Publication Date: 2005**

**Descriptors:** Stainless steels; Titanium dioxide; Nanostructured materials; Microstructure; Hydroxyapatite; Phase composition; Plasma spraying; Photocatalysis

## Appendix A-5. Irrelevant Titles

**Subj Catg:** 57, Finishing

7/8/314 (Item 208 from file: 32)

METADEX

(c) 2009 CSA. All rights reserved.

0001493067 IP Accession No: 200602-57-05679

**Electrolytic deposition of titania films as interference coatings on biomedical implants: Microstructure, chemistry and nano--mechanical properties**

**Publication Date: 2006**

**Descriptors:** Austenitic stainless steels; Heat resistant steels; Titanium base alloys; Titanium dioxide; Nanostructure; Surgical implants; Biocompatibility; Deposition; Coatings; Mechanical properties; Thin films

**Subj Catg:** 57, Finishing

**Material Class:** Austenitic stainless steels

**Materials:** 316L; Ti-6Al-4V

7/8/315 (Item 209 from file: 32)

METADEX

(c) 2009 CSA. All rights reserved.

0001488512 IP Accession No: 200514-32-38069

**The preparation and spectrum characteristic of europium-doped titania nanocrystals**

**Publication Date: 2005**

**Descriptors:** Titanium dioxide; Nanocrystals; Europium; Doped crystals; Anatase; Band structure of solids; Excitation spectra; Photoluminescence; Energy gaps (solid state); Crystal defects; Sol gel **processes**; Excitation; Luminescence; Band spectra; Emission; Excitons; Grains; X-rays; Sol-gel; Spectral lines

**Subj Catg:** 32, Physical Properties

7/8/316 (Item 210 from file: 32)

METADEX

(c) 2009 CSA. All rights reserved.

0001483548 IP Accession No: 200513-34-34682

**Electrochemical performance of granulated titania nanoparticles**

**Publication Date: 2004**

**Descriptors:** Titanium dioxide; Nanoparticles; Charge; Granulation; Electrodes; Granular materials; Granules; Spray drying; Anatase; Power sources; Sol-gel; Phase composition; Specific surface; Calcination

**Subj Catg:** 34, Chemical and Electrochemical Properties

7/8/317 (Item 211 from file: 32)

METADEX

(c) 2009 CSA. All rights reserved.

## Appendix A-5. Irrelevant Titles

0001468277 IP Accession No: 200509-41-21080

**Characterization of nanocrystalline anatase titania: an in situ HTXRD study**

**Publication Date: 2005**

**Descriptors:** Anatase; Rutile; Titanium dioxide; Phase transformations; Crystallites; Synthesis; Hydrolysis

**Subj Catg:** 41, Ores and Raw Materials

7/8/319 (Item 213 from file: 32)

METADEX

(c) 2009 CSA. All rights reserved.

0001428298 IP Accession No: 200507-57-14747

**Degradation and stabilisation of polymers and coatings: nano versus pigmentary titania particles**

**Publication Date: 2004**

**Descriptors:** Stainless steels; Aluminum; Painting; Pigments; Titanium dioxide; Particle size; Photocatalysis

**Subj Catg:** 57, Finishing

7/8/320 (Item 214 from file: 32)

METADEX

(c) 2009 CSA. All rights reserved.

0001407577 IP Accession No: 200503-61-09589

**Nanocarving of Bulk Titania Crystals into Oriented Arrays of Single-Crystal Nanofibers via Reaction with Hydrogen-Bearing Gas**

**Publication Date: 2004**

**Descriptors:** Nanostructure; Titanium oxides; Single crystals; Crystal structure; Nanotubes; Titanium dioxide; Nanowires; Nanofibers; Hydrogen; Chemical reactions; Mass **production**; Electronic devices; Fabrication; Photocatalysis

**Subj Catg:** 61, Engineering Components and Structures

7/8/321 (Item 215 from file: 32)

METADEX

(c) 2009 CSA. All rights reserved.

0001394379 IP Accession No: 200412-57-2274

**FABRICATION OF NANO-STRUCTURED TITANIA - THIN-FILMS ON CARBON-COATED NICKEL SHEETS**

**Publication Date: 2004**

**Descriptors:** Titanium dioxide; Semiconductors; Ceramic coatings; Nickel; Sheet metal; Interlayers; Sol gel **process**; Immersion coating; Catalysis; Nanostructure; Solar cells; Thin films; Carbon nanotubes; Plasma enhanced chemical vapor deposition

**Subj Catg:** 57, Finishing

## Appendix A-5. Irrelevant Titles

7/8/322 (Item 216 from file: 32)

METADEX

(c) 2009 CSA. All rights reserved.

0001388151 IP Accession No: 200506-57-10400

**Abrasion behavior of nanostructured and conventional titania coatings thermally sprayed via APS, VPS and HVOF**

**Publication Date: 2004**

**Descriptors:** Ceramic coatings; Nanostructure; Abrasion resistant coatings; Titanium dioxide; Flame spraying; Morphology; Hardness; Porosity; Vacuum plasma spraying; High velocity oxyfuel spraying; Vickers indentation; Protective coatings; Low carbon steels

**Subj Catg:** 57, Finishing

7/8/323 (Item 217 from file: 32)

METADEX

(c) 2009 CSA. All rights reserved.

0001380238 IP Accession No: 200404-42-0429

**Structure transition of nano-titania during calcination.**

**Publication Date: 2003**

**Descriptors:** Titanium; Extraction; Roasting; Rutile; Beneficiation; Titanium dioxide; Reduction (chemical)

**Subj Catg:** 42, Extraction and Smelting

7/8/325 (Item 219 from file: 32)

METADEX

(c) 2009 CSA. All rights reserved.

0001345222 IP Accession No: 200211-57-2320

**Experiments and modeling of the deposition of nano-structured alumina-titania coatings by detonation waves**

**Publication Date: 2002**

**Descriptors:** Journal article; Carbon steels; Coating; Ceramic coatings; Detonation; Microhardness

**Subj Catg:** 57, Finishing

7/8/326 (Item 220 from file: 32)

METADEX

(c) 2009 CSA. All rights reserved.

0001339582 IP Accession No: 200303-57-0571

**Synthesis of nanocrystalline titania films by micro-arc oxidation**

**Publication Date: 2002**

**Descriptors:** Journal article; Titanium; Coating; Oxide coatings; Arc deposition; Adhesion; Nanostructure; Grain size; Titania; Nanocrystalline films; Synthesis; Nanocrystalline titania films; Films; Nanocrystalline titania; Nanocrystalline materials; Titania films; Adhesive

## Appendix A-5. Irrelevant Titles

strength; Anatase; Catalyst; Crystalline; Dental **application**

**Subj Catg:** 57, Finishing

7/8/327 (Item 221 from file: 32)

METADEX

(c) 2009 CSA. All rights reserved.

0001298940 IP Accession No: 200109-57-1324

**Scratch testing of nanocrystalline alumina + 13%titania + zirconia**

**Publication Date: 2001**

**Descriptors:** Symposia; Reference lists; **Process** parameters; **Process** conditions; Plasma spraying; Coating methods; Spraying; Sprayed coatings; Coatings; Ceramic coatings; Nonmetallic coatings; Alumina; Ceramics; Oxides ; Wear; Hardness; Mechanical properties; Fractures; Microstructure; Cracking; Defects; Conference paper; Carbon steels; Coating; Oxides; Coatings; Powder spraying; Plasma spraying; Scratch tests; Wear rate; **Processing** effects; Melting

**Identifiers:** NANOTECHNOLOGY

**Subj Catg:** 57, Finishing

7/8/328 (Item 222 from file: 32)

METADEX

(c) 2009 CSA. All rights reserved.

0001295921 IP Accession No: 200108-57-1142

**Properties and microstructures of nanostructured alumina-13% titania+zirconia coatings**

**Publication Date: 2001**

**Descriptors:** Extended abstract; Carbon steels; Coating; Nanomaterials; Coatings; Oxides; Plasma spraying; Microhardness; **Processing** effects

**Subj Catg:** 57, Finishing

7/8/329 (Item 223 from file: 32)

METADEX

(c) 2009 CSA. All rights reserved.

0001196237 IP Accession No: 200105-57-0804

**Fabrication and evaluation of plasma sprayed nanostructured alumina- titania coatings with superior properties**

**Publication Date: 2001**

**Descriptors:** Conference paper; Carbon steels; Coating; Ceramic coatings; Nanomaterials; Coatings; Mixtures; Aluminum oxide; Titanium dioxide; Plasma spraying; Powder spraying; Adhesion; Wear resistance; Diamond pyramid hardness; Fracture toughness

**Subj Catg:** 57, Finishing

7/8/330 (Item 1 from file: 34)

## Appendix A-5. Irrelevant Titles

SciSearch(R) Cited Ref Sci

(c) 2010 The Thomson Corp. All rights reserved.

20091888 **Genuine Article#:** 537SC **Number of References:** 41

**Title:** Size control synthesis of sulfur doped titanium dioxide (anatase) nanoparticles, its optical property and its photo catalytic reactivity for CO<sub>2</sub> + H<sub>2</sub>O conversion and phenol degradation ( ABSTRACT AVAILABLE )

**Publication date:** 20091200

**Journal Subject Category:** CHEMISTRY, APPLIED; CHEMISTRY, PHYSICAL; ENERGY & FUELS; ENGINEERING, CHEMICAL

**Descriptors:** SCIAuthor Keywords: S doped TiO<sub>2</sub> ; photocatalyst ; CO<sub>2</sub> conversion ; phenol degradation ; UV ; IR radiation

**Identifiers:** KeyWord Plus(R): SOL-GEL METHOD; VISIBLE-LIGHT; PHOTOCATALYTIC ACTIVITY; TIO<sub>2</sub> POWDERS; NANOCRYSTALLINE TITANIA; SURFACE; SPECTROSCOPY; TOLUENE; CARBON; WATER

7/8/331 (Item 2 from file: 34)

SciSearch(R) Cited Ref Sci

(c) 2010 The Thomson Corp. All rights reserved.

20076640 **Genuine Article#:** 534TI **Number of References:** 22

**Title:** Phase transformation of nanostructured titanium dioxide from anatase-to-rutile via combined ultrasound assisted sol-gel technique ( ABSTRACT AVAILABLE )

**Publication date:** 20100200

**Journal Subject Category:** ACOUSTICS; CHEMISTRY, MULTIDISCIPLINARY

**Descriptors:** SCIAuthor Keywords: Sol-gel ; Acoustic cavitation (ultrasound) ; Titanium dioxide (TiO<sub>2</sub>) ; Anatase-to-rutile phase transformation

**Identifiers:** KeyWord Plus(R): THIN-FILM; NANOPARTICLES; MICROEMULSION; CAVITATION; PARTICLES

7/8/332 (Item 3 from file: 34)

SciSearch(R) Cited Ref Sci

(c) 2010 The Thomson Corp. All rights reserved.

20075168 **Genuine Article#:** 534SI **Number of References:** 22

**Title:** Biocompatibility and in vitro antineoplastic drug-loaded trial of titania nanotubes prepared by anodic oxidation of a pure titanium ( ABSTRACT AVAILABLE )

**Publication date:** 20091200

**Journal Subject Category:** CHEMISTRY, MULTIDISCIPLINARY

**Descriptors:** SCIAuthor Keywords: drug delivery ; biocompatibility ; titania nanotubes ; cell adhesion ; cisplatin

**Identifiers:** KeyWord Plus(R): TIO<sub>2</sub> NANOTUBE; PHOTOELECTROCHEMICAL PROPERTIES; OSTEOPROGENITOR RESPONSE; CATALYTIC-PROPERTIES; ARRAYS; FABRICATION

## Appendix A-5. Irrelevant Titles

7/8/333 (Item 4 from file: 34)

SciSearch(R) Cited Ref Sci

(c) 2010 The Thomson Corp. All rights reserved.

20072721 **Genuine Article#:** 536IK **Number of References:** 31

**Title:** Dependence of surface atomic arrangement of titanium dioxide on metallic nanowire nucleation by thermally assisted photoreduction ( ABSTRACT AVAILABLE )

**Publication date:** 20100000

**Journal Subject Category:** CHEMISTRY, PHYSICAL; PHYSICS, ATOMIC, MOLECULAR & CHEMICAL

**Identifiers:** KeyWord Plus(R): TIO2 THIN-FILMS; TIME-RESOLVED SPECTROSCOPY; ROOM-TEMPERATURE; ANATASE TIO2; DEPOSITION; PHOTOLUMINESCENCE; PHOTOCATALYSIS; ZNO; ELECTRODE; EMISSION

7/8/334 (Item 5 from file: 34)

SciSearch(R) Cited Ref Sci

(c) 2010 The Thomson Corp. All rights reserved.

20033074 **Genuine Article#:** 532IA **Number of References:** 55

**Title:** Tailoring the surface functionalities of titania nanotube arrays ( ABSTRACT AVAILABLE )

**Publication date:** 20100100

**Journal Subject Category:** ENGINEERING, BIOMEDICAL; MATERIALS SCIENCE, BIOMATERIALS

**Descriptors:** SCIAuthor Keywords: Titanium oxide ; Titania nanotubes ; Surface modifications ; Plasma polymerizations

**Identifiers:** KeyWord Plus(R): NANOPOROUS ALUMINA MEMBRANES; ANODIC OXIDE-FILMS; TIO2 NANOTUBES; PLASMA POLYMER; ETHYLENE-GLYCOL; POROUS SILICON; CELL-ADHESION; FABRICATION; SCALE; COATINGS

7/8/335 (Item 6 from file: 34)

SciSearch(R) Cited Ref Sci

(c) 2010 The Thomson Corp. All rights reserved.

20031456 **Genuine Article#:** 531ZE **Number of References:** 29

**Title:** Functionalized monolayers on mesoporous silica and on titania nanoparticles for mercuric sensing ( ABSTRACT AVAILABLE )

**Publication date:** 20100000

**Journal Subject Category:** CHEMISTRY, ANALYTICAL

**Identifiers:** KeyWord Plus(R): ATOMIC-ABSORPTION-SPECTROMETRY; TOXIC METAL-IONS; PERMANENT MODIFIERS; SELECTIVE DETECTION; AQUEOUS-SOLUTION; WATER; FLUOROIONOPHORE; CHEMODOSIMETER; CHEMOSENSOR; BIOSENSORS

7/8/336 (Item 7 from file: 34)

## Appendix A-5. Irrelevant Titles

SciSearch(R) Cited Ref Sci

(c) 2010 The Thomson Corp. All rights reserved.

20019619 **Genuine Article#:** 530AD **Number of References:** 49

**Title: Infrared and Computational Studies on Interactions of Carbon Dioxide and Titania Nanoparticles with Acetate Groups ( ABSTRACT AVAILABLE )**

**Publication date:** 20091217

**Journal Subject Category:** CHEMISTRY, PHYSICAL; NANOSCIENCE & NANOTECHNOLOGY; MATERIALS SCIENCE, MULTIDISCIPLINARY

**Identifiers:** KeyWord Plus(R): SOL-GEL ROUTE; TOTAL-ENERGY CALCULATIONS; AUGMENTED-WAVE METHOD; DOT-O INTERACTIONS; SUPERCRITICAL CO<sub>2</sub>; BASIS-SETS; SPECTROSCOPY; PSEUDOPOTENTIALS; FLUIDS; FTIR

7/8/337 (Item 8 from file: 34)

SciSearch(R) Cited Ref Sci

(c) 2010 The Thomson Corp. All rights reserved.

20012193 **Genuine Article#:** 529TR **Number of References:** 36

**Title: Preparation and characterization of [60] fullerene nanoparticles supported on titania used as a photocatalyst ( ABSTRACT AVAILABLE )**

**Publication date:** 20091005

**Journal Subject Category:** CHEMISTRY, PHYSICAL

**Descriptors:** SCIAuthor Keywords: Titanium oxide ; [60] Fullerene ; Photocatalysis ; Supported catalysts ; Preparation of catalysts ; Incipient wetness impregnation ; DRS ; XRD ; BET ; Microelectrophoresis

**Identifiers:** KeyWord Plus(R): ELECTROCHEMICAL DETECTION; AQUEOUS SYSTEMS; TRIPLET-STATE; SOLAR-ENERGY; C-60; C60; CARBON; WATER; C-70; ABSORPTION

7/8/338 (Item 9 from file: 34)

SciSearch(R) Cited Ref Sci

(c) 2010 The Thomson Corp. All rights reserved.

19997173 **Genuine Article#:** 527TF **Number of References:** 23

**Title: Nanohybrids of Ultrathin Titania Nanosheets and Zinc Oxide Nanoparticles by an Electrostatic Interaction ( ABSTRACT AVAILABLE )**

**Publication date:** 20100100

**Journal Subject Category:** CHEMISTRY, MULTIDISCIPLINARY; NANOSCIENCE & NANOTECHNOLOGY; MATERIALS SCIENCE, MULTIDISCIPLINARY; PHYSICS, APPLIED; PHYSICS, CONDENSED MATTER

**Descriptors:** SCIAuthor Keywords: Nanosheet ; Nanoparticle ; Intercalation ; Exfoliation ; Reassembly ; Sol-Gel Method ; Nanohybrid ; N-2 Adsorption-Desorption Isotherm ; Mesoporous Material

**Identifiers:** KeyWord Plus(R): EXFOLIATION; FILMS

## Appendix A-5. Irrelevant Titles

7/8/339 (Item 10 from file: 34)

SciSearch(R) Cited Ref Sci

(c) 2010 The Thomson Corp. All rights reserved.

19986676 **Genuine Article#:** 528JI **Number of References:** 44

**Title:** Three-dimensionally ordered macroporous (3DOM) gold-nanoparticle -doped titanium dioxide (GTD) photonic crystals modified electrodes for hydrogen peroxide biosensor ( ABSTRACT AVAILABLE )

**Publication date:** 20091215

**Journal Subject Category:** BIOPHYSICS; BIOTECHNOLOGY & APPLIED MICROBIOLOGY; CHEMISTRY, ANALYTICAL ; ELECTROCHEMISTRY; NANOSCIENCE & NANOTECHNOLOGY

**Descriptors:** SCIAuthor Keywords: Gold-nanoparticle-doped ; Titanium dioxide ; Photonic crystals ; Horseradish peroxidase ; Electrocatalysis

**Identifiers:** KeyWord Plus(R): HORSERADISH-PEROXIDASE; DIRECT ELECTROCHEMISTRY; INVERSE OPAL; FILM; TIO2; ELECTROCATALYSIS; IMMOBILIZATION; IMMUNOSENSOR; BIOELECTROCHEMISTRY; BIOELECTROCATALYSIS

7/8/340 (Item 11 from file: 34)

SciSearch(R) Cited Ref Sci

(c) 2010 The Thomson Corp. All rights reserved.

19980179 **Genuine Article#:** 526RW **Number of References:** 34

**Title:** Synthesis of titanium dioxide nanocrystalline layers using hexaprismatic shaped mu-oxo Ti(IV) alkoxo carboxylates as precursors ( ABSTRACT AVAILABLE )

**Publication date:** 20091116

**Journal Subject Category:** CHEMISTRY, INORGANIC & NUCLEAR; CRYSTALLOGRAPHY

**Descriptors:** SCIAuthor Keywords: Hexanuclear mu-oxo titanium(IV) alkoxo carboxylato complexes ; Thermal properties ; VT IR ; CVD ; TiO2 layers

**Identifiers:** KeyWord Plus(R): CHEMICAL-VAPOR-DEPOSITION; TIO2 THIN-FILMS; SILICATE GATE DIELECTRICS; THERMAL-BEHAVIOR; CVD; GROWTH; MOCVD; OXIDE; MICROSTRUCTURE; CHEMISTRY

7/8/341 (Item 12 from file: 34)

SciSearch(R) Cited Ref Sci

(c) 2010 The Thomson Corp. All rights reserved.

19976076 **Genuine Article#:** 525WW **Number of References:** 17

**Title:** NANO-VANADIUM DOPING-DRIVEN LOW TEMPERATURE STRUCTURAL PHASE TRANSFORMATION IN TITANIA ( ABSTRACT AVAILABLE )

**Publication date:** 20091120

**Journal Subject Category:** PHYSICS, APPLIED; PHYSICS, CONDENSED MATTER; PHYSICS, MATHEMATICAL

**Descriptors:** SCIAuthor Keywords: V-doped n-TiO2 ; X-ray diffraction ; scanning electron

## Appendix A-5. Irrelevant Titles

microscopy ; magnetization

**Identifiers:** KeyWord Plus(R): ROOM-TEMPERATURE; THIN-FILMS;  
FERROMAGNETISM; OXIDE; DIOXIDE

7/8/342 (Item 13 from file: 34)

SciSearch(R) Cited Ref Sci

(c) 2010 The Thomson Corp. All rights reserved.

19972419 **Genuine Article#:** 524KJ **Number of References:** 52

**Title:** Electrostatic interactions for directed assembly of nanostructured materials: composites of titanium dioxide nanotubes with gold nanoparticles ( ABSTRACT AVAILABLE )

**Publication date:** 20090000

**Journal Subject Category:** CHEMISTRY, PHYSICAL; MATERIALS SCIENCE, MULTIDISCIPLINARY

**Identifiers:** KeyWord Plus(R): CARBON NANOTUBES; TITANATE NANOTUBES; TIO<sub>2</sub> NANOTUBES; SURFACE MODIFICATION; QUANTUM DOTS; FABRICATION; NANORIBBONS; SUSPENSIONS; TRANSITION; DEPOSITION

7/8/344 (Item 15 from file: 34)

SciSearch(R) Cited Ref Sci

(c) 2010 The Thomson Corp. All rights reserved.

19964546 **Genuine Article#:** 524AG **Number of References:** 24

**Title:** Palladium/titanium dioxide nanofibers for glycerol electrooxidation in alkaline medium ( ABSTRACT AVAILABLE )

**Publication date:** 20091100

**Journal Subject Category:** ELECTROCHEMISTRY

**Descriptors:** SCIAuthor Keywords: Pd/TiO<sub>2</sub> nanofibers ; Glycerol ; Electrooxidation ; Poisoning intermediate

**Identifiers:** KeyWord Plus(R): ALCOHOL FUEL-CELLS; PD NANOWIRE ARRAYS; ELECTROCATALYTIC OXIDATION; ETHANOL ELECTROOXIDATION; METHANOL; PLATINUM; ELECTRODES; PRODUCTS; CATALYST; KINETICS

7/8/345 (Item 16 from file: 34)

SciSearch(R) Cited Ref Sci

(c) 2010 The Thomson Corp. All rights reserved.

19946844 **Genuine Article#:** 521TR **Number of References:** 52

**Title:** Titania Nanostructures Fabricated by Atomic Layer Deposition Using Spherical Protein Cages ( ABSTRACT AVAILABLE )

**Publication date:** 20091201

**Journal Subject Category:** CHEMISTRY, MULTIDISCIPLINARY; CHEMISTRY, PHYSICAL; MATERIALS SCIENCE, MULTIDISCIPLINARY

**Identifiers:** KeyWord Plus(R): THIN-FILMS; OSMOTIC DEHYDRATION; TIO<sub>2</sub> SURFACES; FERRITIN; NANOPARTICLES; APOFERRITIN; CELLS;

## Appendix A-5. Irrelevant Titles

PHOTOCATALYSIS; NANOCOMPOSITES; ISOPROPOXIDE

7/8/346 (Item 17 from file: 34)

SciSearch(R) Cited Ref Sci

(c) 2010 The Thomson Corp. All rights reserved.

19944582 **Genuine Article#:** 522EO **Number of References:** 29

**Title:** Mechanism and kinetics of Pb(II) adsorption on ultrathin nanocrystalline titania coatings ( ABSTRACT AVAILABLE )

**Publication date:** 20091230

**Journal Subject Category:** ENGINEERING, ENVIRONMENTAL; ENGINEERING, CIVIL; ENVIRONMENTAL SCIENCES

**Descriptors:** SCIAuthor Keywords: Titania coatings ; Pb(II) ; QCM ; Mechanism ; Kinetics

**Identifiers:** KeyWord Plus(R): QUARTZ-CRYSTAL MICROBALANCE; ACTIVATED CARBON; AQUEOUS-SOLUTION; REMOVAL; LEAD; PROTEIN; SURFACE; TIO<sub>2</sub>; OPTIMIZATION; EQUILIBRIUM

7/8/347 (Item 18 from file: 34)

SciSearch(R) Cited Ref Sci

(c) 2010 The Thomson Corp. All rights reserved.

19925050 **Genuine Article#:** 522ZR **Number of References:** 32

**Title:** Single-Step Synthesis and Structural Study of Mesoporous Sulfated Titania Nanopowder by a Controlled Hydrolysis Process ( ABSTRACT AVAILABLE )

**Publication date:** 20091100

**Journal Subject Category:** NANOSCIENCE & NANOTECHNOLOGY; MATERIALS SCIENCE, MULTIDISCIPLINARY

**Descriptors:** SCIAuthor Keywords: mesoporous sulfated titania ; single-step synthesis ; titanium oxysulfate ; seeding method

**Identifiers:** KeyWord Plus(R): SOLID SUPERACID CATALYST; VISIBLE-LIGHT; PHOTOCATALYTIC PERFORMANCE; METAL-OXIDES; DOPED ZRO<sub>2</sub>; IRON-OXIDE; TIO<sub>2</sub>; ACIDITY; SULFUR; DICHLORODIFLUOROMETHANE

7/8/348 (Item 19 from file: 34)

SciSearch(R) Cited Ref Sci

(c) 2010 The Thomson Corp. All rights reserved.

19925049 **Genuine Article#:** 522ZR **Number of References:** 55

**Title:** New Approach Toward Nanosized Ferrous Ferric Oxide and Fe(3)O<sub>4</sub>-doped Titanium Dioxide Photocatalysts ( ABSTRACT AVAILABLE )

**Publication date:** 20091100

**Journal Subject Category:** NANOSCIENCE & NANOTECHNOLOGY; MATERIALS SCIENCE, MULTIDISCIPLINARY

**Descriptors:** SCIAuthor Keywords: Titanium dioxide ; ferrous ferric oxide ; sol-gel synthesis ; doping ; photocatalysis

## Appendix A-5. Irrelevant Titles

**Identifiers:** KeyWord Plus(R): SOL-GEL METHOD; TIO2 PARTICLES; DEGRADATION MECHANISM; COTTON FABRICS; CATALYSTS; DYE; POWDERS; ACID; NANOPARTICLES; ADSORPTION

7/8/349 (Item 20 from file: 34)

SciSearch(R) Cited Ref Sci

(c) 2010 The Thomson Corp. All rights reserved.

19912897 **Genuine Article#:** 519KM **Number of References:** 25

**Title:** Phonon confinement in individual titanium dioxide nanowires ( ABSTRACT AVAILABLE )

**Publication date:** 20091200

**Journal Subject Category:** OPTICS

**Descriptors:** SCIAuthor Keywords: Nanowires ; Phonons ; Titanium dioxide

**Identifiers:** KeyWord Plus(R): TIO2 NANOCRYSTALS; CARBON NANOTUBES; RAMAN-SPECTRUM; GROWTH; RUTILE; VAPOR; SIZE

7/8/350 (Item 21 from file: 34)

SciSearch(R) Cited Ref Sci

(c) 2010 The Thomson Corp. All rights reserved.

19911089 **Genuine Article#:** 519RP **Number of References:** 15

**Title:** Thermal properties and characterization of the titania nanotube and silver nanoparticle systems ( ABSTRACT AVAILABLE )

**Publication date:** 20091000

**Journal Subject Category:** MATERIALS SCIENCE, CERAMICS

**Descriptors:** SCIAuthor Keywords: Titania Nanotube ; Silver Nanoparticle ; Thermal Properties ; Sonochemical **Process**

**Identifiers:** KeyWord Plus(R): CARBON NANOTUBES; MORPHOLOGY; CELLS; TIO2

7/8/351 (Item 22 from file: 34)

SciSearch(R) Cited Ref Sci

(c) 2010 The Thomson Corp. All rights reserved.

19903951 **Genuine Article#:** 518DI **Number of References:** 8

**Title:** Formation of titanium dioxide nanostructures in the interlayer space of clay minerals ( ABSTRACT AVAILABLE )

**Publication date:** 20091000

**Journal Subject Category:** CHEMISTRY, PHYSICAL

7/8/353 (Item 24 from file: 34)

SciSearch(R) Cited Ref Sci

(c) 2010 The Thomson Corp. All rights reserved.

19899671 **Genuine Article#:** 518BE **Number of References:** 57

**Title:** Photodegradation of DMMP and CEES on zirconium doped titania nanoparticles

## Appendix A-5. Irrelevant Titles

( ABSTRACT AVAILABLE )

**Publication date:** 20091109

**Journal Subject Category:** CHEMISTRY, PHYSICAL; ENGINEERING, ENVIRONMENTAL; ENGINEERING, CHEMICAL

**Descriptors:** SCIAuthor Keywords: TiO<sub>2</sub> ; Zirconium ; Photocatalysis ; DMMP ; CEES ; FTIR ; Raman

**Identifiers:** KeyWord Plus(R): 2-CHLOROETHYL ETHYL SULFIDE; ANATASE-TYPE TIO<sub>2</sub>; PHOTOCATALYTIC DEGRADATION; DIMETHYL METHYLPHOSPHONATE; PHASE-STABILITY; RAMAN-SPECTRUM; RUTILE TIO<sub>2</sub>; GAS-PHASE; SURFACE; ADSORPTION

7/8/356 (Item 27 from file: 34)

SciSearch(R) Cited Ref Sci

(c) 2010 The Thomson Corp. All rights reserved.

19885926 **Genuine Article#:** 517AM **Number of References:** 46

**Title:** Screening tests for the evaluation of nanoparticle titania photocatalysts ( ABSTRACT AVAILABLE )

**Publication date:** 20091100

**Journal Subject Category:** BIOTECHNOLOGY & APPLIED MICROBIOLOGY; CHEMISTRY, MULTIDISCIPLINARY; ENGINEERING, CHEMICAL

**Descriptors:** SCIAuthor Keywords: photocatalysis ; titania ; methylene blue ; visible light ; screening

**Identifiers:** KeyWord Plus(R): CONTINUOUS HYDROTHERMAL SYNTHESIS; VISIBLE-LIGHT IRRADIATION; NEAR-CRITICAL WATER; ONE-STEP SYNTHESIS; METHYLENE-BLUE; HYDROGEN GENERATION; SOLID-SOLUTIONS; TIO<sub>2</sub>; PHOTOOXIDATION; DIOXIDE

7/8/358 (Item 29 from file: 34)

SciSearch(R) Cited Ref Sci

(c) 2010 The Thomson Corp. All rights reserved.

19884853 **Genuine Article#:** 516ZX **Number of References:** 59

**Title:** Synthesis and Characterization of Titania-Graphene Nanocomposites ( ABSTRACT AVAILABLE )

**Publication date:** 20091119

**Journal Subject Category:** CHEMISTRY, PHYSICAL; NANOSCIENCE & NANOTECHNOLOGY; MATERIALS SCIENCE, MULTIDISCIPLINARY

**Identifiers:** KeyWord Plus(R): EXFOLIATED GRAPHITE OXIDE; CARBON NANOTUBES; AQUEOUS DISPERSIONS; SURFACE-AREA; ANATASE TIO<sub>2</sub>; SHEETS; NANOPARTICLES; COMPOSITES; NANOSTRUCTURES; NANOSHEETS

7/8/359 (Item 30 from file: 34)

SciSearch(R) Cited Ref Sci

## Appendix A-5. Irrelevant Titles

(c) 2010 The Thomson Corp. All rights reserved.

19861585 **Genuine Article#:** 513VM **Number of References:** 19

**Title:** Nanostructure development in photodeposited, titania-based thin films ( ABSTRACT AVAILABLE )

**Publication date:** 20091100

**Journal Subject Category:** MATERIALS SCIENCE, MULTIDISCIPLINARY

**Identifiers:** KeyWord Plus(R): SIMULATION; ALKOXIDES

7/8/360 (Item 31 from file: 34)

SciSearch(R) Cited Ref Sci

(c) 2010 The Thomson Corp. All rights reserved.

19853914 **Genuine Article#:** 512QJ **Number of References:** 23

**Title:** Active anatase (001)-like surface of hydrothermally synthesized titania nanotubes ( ABSTRACT AVAILABLE )

**Publication date:** 20091106

**Journal Subject Category:** CHEMISTRY, PHYSICAL; PHYSICS, ATOMIC, MOLECULAR & CHEMICAL

**Identifiers:** KeyWord Plus(R): DELAMINATED ANATASE; TIO<sub>2</sub>; NANOSHEETS; CHEMISTRY; TITANATES; DIOXIDE; NMR

7/8/361 (Item 32 from file: 34)

SciSearch(R) Cited Ref Sci

(c) 2010 The Thomson Corp. All rights reserved.

19853791 **Genuine Article#:** 513BX **Number of References:** 34

**Title:** Particle diameter prediction in supercritical nanoparticle synthesis using three-dimensional CFD simulations. Validation for anatase titanium dioxide production ( ABSTRACT AVAILABLE )

**Publication date:** 20090701

**Journal Subject Category:** ENGINEERING, CHEMICAL

**Descriptors:** SCIAuthor Keywords: CFD ; Supercritical synthesis ; Titanium dioxide ; Nanoparticles

**Identifiers:** KeyWord Plus(R): CONTINUOUS HYDROTHERMAL SYNTHESIS; VAPOR-LIQUID-EQUILIBRIA; CARBON-DIOXIDE; OXIDE NANOPARTICLES; HIGH-PRESSURES; GAS-PHASE; CRYSTALLIZATION; ANTISOLVENT; CONVECTION; FLUIDS

7/8/362 (Item 33 from file: 34)

SciSearch(R) Cited Ref Sci

(c) 2010 The Thomson Corp. All rights reserved.

19840667 **Genuine Article#:** 511WJ **Number of References:** 26

**Title:** Transformation of microporous titanium glycolate nanorods into mesoporous anatase titania nanorods by hot water treatment ( ABSTRACT AVAILABLE )

**Publication date:** 20091200

**Journal Subject Category:** MATERIALS SCIENCE, MULTIDISCIPLINARY

## Appendix A-5. Irrelevant Titles

**Identifiers:** KeyWord Plus(R): TIO2 THIN-FILMS; PHOTOCATALYTIC ACTIVITY; ETHYLENE-GLYCOL; ACID; DEGRADATION; POLLUTANTS; NANOWIRES; ALCOHOLS; OXIDE

7/8/363 (Item 34 from file: 34)

SciSearch(R) Cited Ref Sci

(c) 2010 The Thomson Corp. All rights reserved.

19835357 **Genuine Article#:** 510GT **Number of References:** 19

**Title:** MICROWAVE-ASSISTED HYDROTHERMAL SYNTHESIS OF NITROGEN-DOPED TITANIA NANOPARTICLES ( ABSTRACT AVAILABLE )

**Publication date:** 20081200

**Journal Subject Category:** MATERIALS SCIENCE, MULTIDISCIPLINARY

**Descriptors:** SCIAuthor Keywords: Nitrogen-doped titania ; photocatalyst ; microwave-assisted hydrothermal **process**

**Identifiers:** KeyWord Plus(R): PHOTOCATALYTIC ACTIVITY; SOLVOTHERMAL PROCESS; TIO2

7/8/364 (Item 35 from file: 34)

SciSearch(R) Cited Ref Sci

(c) 2010 The Thomson Corp. All rights reserved.

19832463 **Genuine Article#:** 510IO **Number of References:** 12

**Title:** Detection of Trace Heavy Metals Ions by Arrays of Titania Nanotubes Annealed in Nitrogen ( ABSTRACT AVAILABLE )

**Publication date:** 20090902

**Journal Subject Category:** CHEMISTRY, MULTIDISCIPLINARY

**Descriptors:** SCIAuthor Keywords: Trace heavy metals ions ; Redox response ; Titania nanotubes arrays

**Identifiers:** KeyWord Plus(R): CARBON NANOTUBES; PERFORMANCE; AMMONIA; IMPURITY

7/8/366 (Item 37 from file: 34)

SciSearch(R) Cited Ref Sci

(c) 2010 The Thomson Corp. All rights reserved.

19818757 **Genuine Article#:** 508RU **Number of References:** 20

**Title:** Aerobic oxidation of alpha-pinene catalyzed by nano-titania -supported manganese tetraphenylporphyrin ( ABSTRACT AVAILABLE )

**Publication date:** 20090800

**Journal Subject Category:** CHEMISTRY, MULTIDISCIPLINARY

**Descriptors:** SCIAuthor Keywords: metalloporphyrin ; **air** ; alpha-pinene ; nano-titanium dioxide ; catalysis

**Identifiers:** KeyWord Plus(R): MOLECULAR-OXYGEN; NANOSIZED TIO2;

## Appendix A-5. Irrelevant Titles

METALLOPORPHYRINS; CYCLOHEXANE; PORPHYRINS; ALKANES

7/8/368 (Item 39 from file: 34)

SciSearch(R) Cited Ref Sci

(c) 2010 The Thomson Corp. All rights reserved.

19792381 **Genuine Article#:** 504NZ **Number of References:** 141

**Title:** Photocatalytic electron flow through the interface of titania nanosheets and mesoporous silica hybrid films ( ABSTRACT AVAILABLE )

**Publication date:** 20090905

**Journal Subject Category:** CHEMISTRY, PHYSICAL

**Descriptors:** SCIAuthor Keywords: Charge separation ; Photocurrents ; Electron transfer ; Nanosheet ; Mesoporous silica ; Organic-inorganic hybrids ; Porphyrin ; Viologen

**Identifiers:** KeyWord Plus(R): PHOTOINDUCED CHARGE SEPARATION; CATIONIC PORPHYRIN COMPLEXES; RHODIUM HYDROXIDE NANOPARTICLES; LAYERED NIOBATE K4NB6O17; HIGH-DENSITY ADSORPTION; LANGMUIR-BLODGETT-FILM; LASER FLASH-PHOTOLYSIS; THIN-FILMS; INTERCALATION COMPOUNDS; ENERGY-TRANSFER

7/8/370 (Item 41 from file: 34)

SciSearch(R) Cited Ref Sci

(c) 2010 The Thomson Corp. All rights reserved.

19755973 **Genuine Article#:** 501EK **Number of References:** 39

**Title:** High Lithium Storage in Mixed Crystallographic Phase Nanotubes of Titania and Carbon-Titania ( ABSTRACT AVAILABLE )

**Publication date:** 20091008

**Journal Subject Category:** CHEMISTRY, PHYSICAL; NANOSCIENCE & NANOTECHNOLOGY; MATERIALS SCIENCE, MULTIDISCIPLINARY

**Identifiers:** KeyWord Plus(R): ION BATTERIES; TIO2-B NANOWIRES; ANODE MATERIAL; ELECTROCHEMICAL CHARACTERIZATION; COMPOSITE ELECTRODE; NEGATIVE ELECTRODES; ANATASE; PERFORMANCE; NANOSTRUCTURES; INTERCALATION

7/8/371 (Item 42 from file: 34)

SciSearch(R) Cited Ref Sci

(c) 2010 The Thomson Corp. All rights reserved.

19748563 **Genuine Article#:** 502LO **Number of References:** 47

**Title:** Synthesis of Mn-Substituted Titania Nanosheets and Ferromagnetic Thin Films with Controlled Doping ( ABSTRACT AVAILABLE )

**Publication date:** 20091013

**Journal Subject Category:** CHEMISTRY, PHYSICAL; MATERIALS SCIENCE, MULTIDISCIPLINARY

**Identifiers:** KeyWord Plus(R): RAY PHOTOELECTRON-SPECTROSCOPY; LAYERED DOUBLE HYDROXIDES; POSITIVELY CHARGED NANOSHEETS; ROOM-TEMPERATURE; ULTRATHIN FILMS; COMPOSITE FILMS; DOPED ZNO; GROWTH;

## Appendix A-5. Irrelevant Titles

OXIDE; DELAMINATION

7/8/372 (Item 43 from file: 34)

SciSearch(R) Cited Ref Sci

(c) 2010 The Thomson Corp. All rights reserved.

19747827 **Genuine Article#:** 499ZQ **Number of References:** 20

**Title:** Photocatalytic activity of porous titania nanocrystals prepared by nanoscale permeation process in supercritical CO<sub>2</sub>: Effects of supercritical conditions ( ABSTRACT AVAILABLE )

**Publication date:** 20090915

**Journal Subject Category:** CHEMISTRY, PHYSICAL

**Descriptors:** SCIAuthor Keywords: Supercritical CO<sub>2</sub> ; TiO<sub>2</sub> nanocrystals ; Pores ; Photocatalysis ; Methylene blue

**Identifiers:** KeyWord Plus(R): CARBON-DIOXIDE; TIO2; DEGRADATION; COMPOSITES; CHEMISTRY; POWDERS; FLUIDS; FILMS

7/8/373 (Item 44 from file: 34)

SciSearch(R) Cited Ref Sci

(c) 2010 The Thomson Corp. All rights reserved.

19734165 **Genuine Article#:** 498GE **Number of References:** 33

**Title:** A novel magnetic nanocomposite involving anatase titania coating on silica-modified cobalt ferrite via lower temperature hydrolysis of a water-soluble titania precursor ( ABSTRACT AVAILABLE )

**Publication date:** 20091000

**Journal Subject Category:** MATERIALS SCIENCE, MULTIDISCIPLINARY

**Descriptors:** SCIAuthor Keywords: Nanostructures ; Composites ; Magnetic materials ; X-ray diffraction ; Photoelectron spectroscopy ; Catalytic properties

**Identifiers:** KeyWord Plus(R): VISIBLE-LIGHT IRRADIATION; PHOTOCATALYTIC DEGRADATION; METHYL-ORANGE; MAGNESIUM FERRITE; NANOPARTICLES; OXIDE; SIZE; DECOMPOSITION; DIHYDROXIDE; PARTICLES

7/8/374 (Item 45 from file: 34)

SciSearch(R) Cited Ref Sci

(c) 2010 The Thomson Corp. All rights reserved.

19733728 **Genuine Article#:** 498JV **Number of References:** 15

**Title:** Nanochannel Design by Molecular Imprinting on a Free-Standing Ultrathin Titania Membrane ( ABSTRACT AVAILABLE )

**Publication date:** 20091006

**Journal Subject Category:** CHEMISTRY, MULTIDISCIPLINARY; CHEMISTRY, PHYSICAL; MATERIALS SCIENCE, MULTIDISCIPLINARY

**Identifiers:** KeyWord Plus(R): SOL-GEL PROCESS; FILMS; SIZE

## Appendix A-5. Irrelevant Titles

7/8/375 (Item 46 from file: 34)

SciSearch(R) Cited Ref Sci

(c) 2010 The Thomson Corp. All rights reserved.

19718319 **Genuine Article#:** 497CT **Number of References:** 34

**Title:** Electrochemiluminescence detection based on Ruthenium(II) tris(bipyridine) immobilised in sulfonic-functionalised titania nanoparticles by ion exchange strategy ( ABSTRACT AVAILABLE )

**Publication date:** 20090000

**Journal Subject Category:** CHEMISTRY, ANALYTICAL

**Identifiers:** KeyWord Plus(R): ELECTROGENERATED CHEMILUMINESCENCE BIOSENSOR; CARBON-PASTE ELECTRODE; COMPOSITE FILMS; SILICA NANOPARTICLES; PHOSPHOTUNGSTIC ACID; SENSOR; NAFION; DEHYDROGENASE; SELECTIVITY; MEMBRANE

7/8/376 (Item 47 from file: 34)

SciSearch(R) Cited Ref Sci

(c) 2010 The Thomson Corp. All rights reserved.

19715280 **Genuine Article#:** 496SO **Number of References:** 36

**Title:** La-Ce-Codoping Nano-Titania Photocatalyst: Preparation Via Microwave-Assisted Sol Process, Spectroscopy Characterization and Photocatalytic Activity ( ABSTRACT AVAILABLE )

**Publication date:** 20090800

**Journal Subject Category:** SPECTROSCOPY

**Descriptors:** SCIAuthor Keywords: Nano-titanium dioxide ; La-Ce-codoping ; Microwave-assisted sol process ; Photocatalytic activity

**Identifiers:** KeyWord Plus(R): RAY PHOTOELECTRON-SPECTROSCOPY; TIO2 SUSPENSIONS; LANTHANIDE IONS; VISIBLE-LIGHT; DOPED TIO2; THIN-FILM; DEGRADATION; OXIDATION; IRRADIATION; CATALYSTS

7/8/377 (Item 48 from file: 34)

SciSearch(R) Cited Ref Sci

(c) 2010 The Thomson Corp. All rights reserved.

19707032 **Genuine Article#:** 494WN **Number of References:** 41

**Title:** Fractal character of titania nanoparticles formed by laser ablation ( ABSTRACT AVAILABLE )

**Publication date:** 20090901

**Journal Subject Category:** PHYSICS, APPLIED

**Descriptors:** SCIAuthor Keywords: fractals ; laser ablation ; nanofabrication ; nanoparticles ; Raman spectra ; titanium compounds ; transmission electron microscopy ; X-ray diffraction

**Identifiers:** KeyWord Plus(R): RAMAN-SCATTERING; TIO2 NANOCRYSTALS; SIZE DISTRIBUTION; PHASE EXPLOSION; METAL COLLOIDS; TEMPERATURE; DIMENSION; CATALYSTS; SURFACE; FILMS

## Appendix A-5. Irrelevant Titles

7/8/378 (Item 49 from file: 34)

SciSearch(R) Cited Ref Sci

(c) 2010 The Thomson Corp. All rights reserved.

19702160 **Genuine Article#:** 495OX **Number of References:** 28

**Title:** Erosion-Corrosion Behavior of Plasma-Sprayed Nanostructured Titanium Dioxide Coating in Sodium Chloride-Polystyrene Slurry ( ABSTRACT AVAILABLE )

**Publication date:** 20090900

**Journal Subject Category:** MATERIALS SCIENCE, MULTIDISCIPLINARY;  
METALLURGY & METALLURGICAL ENGINEERING

**Descriptors:** SCIAuthor Keywords: erosion-corrosion ; homogeneous structure ; nanofeed powder ; nanostructured coatings ; plasma air spraying ; splat lamellae ; spraying key parameters ; surface topography

7/8/379 (Item 50 from file: 34)

SciSearch(R) Cited Ref Sci

(c) 2010 The Thomson Corp. All rights reserved.

19700622 **Genuine Article#:** 496QR **Number of References:** 10

**Title:** Preparation and characterization of nano silver-doped mesoporous titania photocatalysts for dye degradation ( ABSTRACT AVAILABLE )

**Publication date:** 20090900

**Journal Subject Category:** CHEMISTRY, APPLIED; CHEMISTRY, PHYSICAL;  
ENGINEERING, CHEMICAL

**Descriptors:** SCIAuthor Keywords: Titanium dioxide ; Sol-gel method ; Ag-doped

**Identifiers:** KeyWord Plus(R): PHENOL

7/8/382 (Item 53 from file: 34)

SciSearch(R) Cited Ref Sci

(c) 2010 The Thomson Corp. All rights reserved.

19676751 **Genuine Article#:** 493GM **Number of References:** 14

**Title:** Efficient sintering of nanocrystalline titanium dioxide films for dye solar cells via raster scanning laser ( ABSTRACT AVAILABLE )

**Publication date:** 20090907

**Journal Subject Category:** PHYSICS, APPLIED

**Descriptors:** SCIAuthor Keywords: laser beam applications ; nanostructured materials ; sintering ; solar cells ; thin films ; titanium compounds

**Identifiers:** KeyWord Plus(R): TIO2

7/8/383 (Item 54 from file: 34)

SciSearch(R) Cited Ref Sci

(c) 2010 The Thomson Corp. All rights reserved.

19661633 **Genuine Article#:** 491SB **Number of References:** 35

**Title:** Comparative Investigations on Nano and Micro Titania Photocatalysts in Degradation and Mineralization: Use of Turbidity in Kinetic Studies ( ABSTRACT

## Appendix A-5. Irrelevant Titles

AVAILABLE )

**Publication date:** 20090900

**Journal Subject Category:** CHEMISTRY, MULTIDISCIPLINARY

**Descriptors:** SCIAuthor Keywords: Photocatalysis ; Nano and micro catalysts ; Turbidity ; Kinetics ; Water purification

**Identifiers:** KeyWord Plus(R): AZO-DYE; AQUEOUS-SOLUTION; UV/TIO2 PROCESS; WASTE-WATER; TIO2; PHOTODEGRADATION; SEMICONDUCTOR; OXIDATION; ZNO; DECOLORIZATION

7/8/384 (Item 55 from file: 34)

SciSearch(R) Cited Ref Sci

(c) 2010 The Thomson Corp. All rights reserved.

19655675 **Genuine Article#:** 492LN **Number of References:** 33

**Title:** Photocatalytic water splitting for hydrogen production under visible light on Ir and Co ionized titania nanotube ( ABSTRACT AVAILABLE )

**Publication date:** 20090815

**Journal Subject Category:** CHEMISTRY, APPLIED; CHEMISTRY, PHYSICAL; ENGINEERING, CHEMICAL

**Descriptors:** SCIAuthor Keywords: **Water** splitting ; Hydrogen **production** ; Titania nanotube ; Ir and Co ; Visible light

**Identifiers:** KeyWord Plus(R): TIO2 PHOTOCATALYSTS; PARTICLES; OXIDES; CDS; NANOCRYSTALLITES; SIZE

7/8/387 (Item 58 from file: 34)

SciSearch(R) Cited Ref Sci

(c) 2010 The Thomson Corp. All rights reserved.

19641334 **Genuine Article#:** 489WT **Number of References:** 45

**Title:** Nanostructural Evolution of Titania-Based Materials Using Modified Titanium Precursors ( ABSTRACT AVAILABLE )

**Publication date:** 20090900

**Journal Subject Category:** MATERIALS SCIENCE, CERAMICS

**Identifiers:** KeyWord Plus(R): ANATASE-TO-RUTILE; X-RAY STRUCTURES; SOL-GEL CHEMISTRY; NANOCRYSTALLINE ANATASE; ALKOXIDE PRECURSORS; CHEMICAL-MODIFICATION; PHASE-TRANSFORMATION; ZIRCONIUM ALKOXIDES; INORGANIC MATRICES; HYBRID MATERIALS

7/8/388 (Item 59 from file: 34)

SciSearch(R) Cited Ref Sci

(c) 2010 The Thomson Corp. All rights reserved.

19640422 **Genuine Article#:** 490BG **Number of References:** 70

**Title:** Photoactivity of mechanochemically prepared nanoparticulate titanium dioxide investigated by EPR spectroscopy ( ABSTRACT AVAILABLE )

**Publication date:** 20090815

**Journal Subject Category:** CHEMISTRY, PHYSICAL

## Appendix A-5. Irrelevant Titles

**Descriptors:** SCIAuthor Keywords: Titanium dioxide ; Mechanochemical synthesis ; EPR spectroscopy ; Spin trapping ; Absorption and scattering

**Identifiers:** KeyWord Plus(R): ELECTRON-SPIN-RESONANCE; ANATASE TIO2 NANOCRYSTALS; TRANSITION-METAL IONS; SOL-GEL METHOD; PHOTOCATALYTIC DEGRADATION; THIN-FILMS; PARTICULATE SUSPENSIONS; MAGNETIC-RESONANCE; AQUEOUS SUSPENSION; OPTICAL-PROPERTIES

7/8/389 (Item 60 from file: 34)

SciSearch(R) Cited Ref Sci

(c) 2010 The Thomson Corp. All rights reserved.

19639573 **Genuine Article#:** 487XD **Number of References:** 16

**Title:** Synthesis of Titanium Dioxide Nanomaterial by Pulsed Laser Ablation in Water ( ABSTRACT AVAILABLE )

**Publication date:** 20090900

**Journal Subject Category:** CHEMISTRY, MULTIDISCIPLINARY; NANOSCIENCE & NANOTECHNOLOGY; MATERIALS SCIENCE, MULTIDISCIPLINARY; PHYSICS, APPLIED; PHYSICS, CONDENSED MATTER

**Descriptors:** SCIAuthor Keywords: Pulsed Laser Ablation in Aqueous Media ; Laser Irradiance ; Titanium Oxide Nanoparticles ; Colloidal Solution

**Identifiers:** KeyWord Plus(R): TIO2; NANOPARTICLES; FILMS; METAL

7/8/391 (Item 62 from file: 34)

SciSearch(R) Cited Ref Sci

(c) 2010 The Thomson Corp. All rights reserved.

19627382 **Genuine Article#:** 487SM **Number of References:** 17

**Title:** Supercapacitor application of nickel oxide-titania nanocomposites ( ABSTRACT AVAILABLE )

**Publication date:** 20091000

**Journal Subject Category:** MATERIALS SCIENCE, COMPOSITES

**Descriptors:** SCIAuthor Keywords: Nano composite ; Oxides ; Electrical properties ; Surface treatments ; Scanning electron microscopy

**Identifiers:** KeyWord Plus(R): TIO2 NANOTUBES; CARBON MATERIALS; CAPACITANCE; STORAGE; GROWTH; ENERGY

7/8/392 (Item 63 from file: 34)

SciSearch(R) Cited Ref Sci

(c) 2010 The Thomson Corp. All rights reserved.

19613666 **Genuine Article#:** 486LK **Number of References:** 53

**Title:** Highly Quasi-Monodisperse Ag Nanoparticles on Titania Nanotubes by Impregnative Aqueous Ion Exchange ( ABSTRACT AVAILABLE )

**Publication date:** 20090901

**Journal Subject Category:** CHEMISTRY, MULTIDISCIPLINARY; CHEMISTRY, PHYSICAL; MATERIALS SCIENCE, MULTIDISCIPLINARY

**Identifiers:** KeyWord Plus(R): FERMI-LEVEL EQUILIBRATION; SILVER

## Appendix A-5. Irrelevant Titles

NANOPARTICLES; TRITITANATE NANOTUBES; INORGANIC NANOTUBES;  
CHARGE-DISTRIBUTION; ESCHERICHIA-COLI; OXIDE NANOTUBES; TIO<sub>2</sub>;  
REDUCTION; CATALYSTS

7/8/393 (Item 64 from file: 34)

SciSearch(R) Cited Ref Sci

(c) 2010 The Thomson Corp. All rights reserved.

19603286 **Genuine Article#:** 486OM **Number of References:** 33

**Title:** Optical investigation on sulfur-doping effects in titanium dioxide nanoparticles ( ABSTRACT AVAILABLE )

**Publication date:** 20091000

**Journal Subject Category:** MATERIALS SCIENCE, MULTIDISCIPLINARY; PHYSICS, APPLIED

**Identifiers:** KeyWord Plus(R): S-DOPED TIO<sub>2</sub>; VISIBLE-LIGHT; PHOTOCATALYTIC ACTIVITY; ANATASE TIO<sub>2</sub>; TIS<sub>2</sub>; ABSORPTION; PHENOL; RUTILE; STM; XPS

7/8/394 (Item 65 from file: 34)

SciSearch(R) Cited Ref Sci

(c) 2010 The Thomson Corp. All rights reserved.

19599316 **Genuine Article#:** 483FC **Number of References:** 20

**Title:** Effects of NH<sub>3</sub> center dot H<sub>2</sub>O pretreatment on the fabrication of uniform titania nanocoating in an aqueous solution ( ABSTRACT AVAILABLE )

**Publication date:** 20091025

**Journal Subject Category:** ENGINEERING, CHEMICAL

**Descriptors:** SCIAuthor Keywords: Nanocoating ; Phosphors ; Sol-gel ; Titania ; NH<sub>3</sub> center dot H<sub>2</sub>O

**Identifiers:** KeyWord Plus(R): LOW-VOLTAGE CATHODOLUMINESCENCE; SULFIDE PHOSPHORS; ZNS PHOSPHORS; ZINC-SULFIDE; DEGRADATION; GLASS; WATER; ACID

7/8/395 (Item 66 from file: 34)

SciSearch(R) Cited Ref Sci

(c) 2010 The Thomson Corp. All rights reserved.

19590647 **Genuine Article#:** 482RX **Number of References:** 44

**Title:** Enhanced Stability Effect in Composite Polymeric Nanofibers Containing Titanium Dioxide and Carbon Nanotubes ( ABSTRACT AVAILABLE )

**Publication date:** 20090820

**Journal Subject Category:** CHEMISTRY, PHYSICAL; NANOSCIENCE & NANOTECHNOLOGY; MATERIALS SCIENCE, MULTIDISCIPLINARY

**Identifiers:** KeyWord Plus(R): SOL-GEL METHOD; PHOTOCATALYTIC ACTIVITY; TIO<sub>2</sub>; DEGRADATION; OXYGEN; ADSORPTION; PARTICLES;

## Appendix A-5. Irrelevant Titles

PHOTODEGRADATION; NANOCOMPOSITES; NANOPARTICLES

7/8/396 (Item 67 from file: 34)

SciSearch(R) Cited Ref Sci

(c) 2010 The Thomson Corp. All rights reserved.

19580386 **Genuine Article#:** 484BN **Number of References:** 16

**Title:** Flame Atomic Absorption Spectrometric Determination of Gold by Solid Phase Extraction Using Modified Nanometer Titanium Dioxide as Sorbent ( ABSTRACT AVAILABLE )

**Publication date:** 20090800

**Journal Subject Category:** CHEMISTRY, MULTIDISCIPLINARY

**Descriptors:** SCIAuthor Keywords: Flame atomic absorption spectrometry ; Gold(III) ; Solid phase extraction ; Nanometer titanium dioxide immobilized on silica gel ; 5-(2-Hydroxy-5-nitrophenylazo)-thiorhodanine

**Identifiers:** KeyWord Plus(R): SPECTROPHOTOMETRIC DETERMINATION; ONLINE PRECONCENTRATION; EMISSION-SPECTROMETRY; METAL-IONS; WATER

7/8/397 (Item 68 from file: 34)

SciSearch(R) Cited Ref Sci

(c) 2010 The Thomson Corp. All rights reserved.

19579469 **Genuine Article#:** 484OD **Number of References:** 43

**Title:** Laser-induced incandescence of titania nanoparticles synthesized in a flame ( ABSTRACT AVAILABLE )

**Publication date:** 20090900

**Journal Subject Category:** OPTICS; PHYSICS, APPLIED

**Identifiers:** KeyWord Plus(R): SOOT-VOLUME FRACTION; PARTICLE-SIZE MEASUREMENTS; GAS TEMPERATURES; SURROUNDING GAS; NANOPARTICLES; PULSED-LASER; LII; DISTRIBUTIONS; CALIBRATION; INTENSITY

7/8/398 (Item 69 from file: 34)

SciSearch(R) Cited Ref Sci

(c) 2010 The Thomson Corp. All rights reserved.

19579156 **Genuine Article#:** 482RW **Number of References:** 41

**Title:** Titania Microparticles and Nanoparticles as Matrixes for in Vitro and in Situ Analysis of Small Molecules by MALDI-MS ( ABSTRACT AVAILABLE )

**Publication date:** 20090815

**Journal Subject Category:** CHEMISTRY, ANALYTICAL

**Identifiers:** KeyWord Plus(R): DESORPTION/IONIZATION MASS-SPECTROMETRY; PARTICLE SUSPENSION MATRIXES; DESORPTION-IONIZATION; TOF-MS; STRUCTURAL-CHARACTERIZATION; POROUS SILICON; TISSUE; PHOSPHOLIPIDS; ROSA; GEL

## Appendix A-5. Irrelevant Titles

7/8/399 (Item 70 from file: 34)

SciSearch(R) Cited Ref Sci

(c) 2010 The Thomson Corp. All rights reserved.

19549717 **Genuine Article#:** 479IW **Number of References:** 46

**Title:** Estimation of zeta potentials of titania nanoparticles by molecular simulation ( ABSTRACT AVAILABLE )

**Publication date:** 20091001

**Journal Subject Category:** PHYSICS, MULTIDISCIPLINARY

**Descriptors:** SCIAuthor Keywords: Nanoparticles ; Titania ; Zeta potential ; Electrostatic potential ; Molecular dynamics ; Poisson-Boltzmann ; Electrophoresis ; Electric Field

**Identifiers:** KeyWord Plus(R): FUNCTIONAL THEORETICAL APPROACH; SPHERICAL COLLOID PARTICLE; ELECTRICAL DOUBLE-LAYER; ATOMISTIC SIMULATION; DYNAMICS SIMULATIONS; TIO2 POLYMORPHS; LIQUID WATER; RUTILE TIO2; SURFACE; ENERGIES

7/8/400 (Item 71 from file: 34)

SciSearch(R) Cited Ref Sci

(c) 2010 The Thomson Corp. All rights reserved.

19537328 **Genuine Article#:** 479HH **Number of References:** 32

**Title:** Flame aerosol synthesis and characterization of pure and carbon coated titania nano powder ( ABSTRACT AVAILABLE )

**Publication date:** 20090800

**Journal Subject Category:** ENGINEERING, CHEMICAL; ENVIRONMENTAL SCIENCES; METEOROLOGY & ATMOSPHERIC SCIENCES

**Descriptors:** SCIAuthor Keywords: TiO2 nano powder ; Flame aerosol synthesis ; Pure anatase phase ; Carbon coated TiO2 powder ; Optical absorption

**Identifiers:** KeyWord Plus(R): CERAMIC POWDERS; DIFFUSION FLAME; PARTICLES; TIO2; RUTILE; PHOTOCATALYSIS; NANOPARTICLES; EVOLUTION

7/8/401 (Item 72 from file: 34)

SciSearch(R) Cited Ref Sci

(c) 2010 The Thomson Corp. All rights reserved.

19536966 **Genuine Article#:** 476WY **Number of References:** 51

**Title:** Electron Transfer from Organic Aminophenyl Acid Sensitizers to Titanium Dioxide Nanoparticle Films ( ABSTRACT AVAILABLE )

**Publication date:** 20090806

**Journal Subject Category:** CHEMISTRY, PHYSICAL; NANOSCIENCE & NANOTECHNOLOGY; MATERIALS SCIENCE, MULTIDISCIPLINARY

**Identifiers:** KeyWord Plus(R): NONADIABATIC MOLECULAR-DYNAMICS; TIO2 SOLAR-CELLS; COUMARIN DYES; NANOCRYSTALLINE TIO2; MEROCYANINE DYES; AB-INITIO; SEMICONDUCTOR; PHOTSENSITIZATION; INJECTION; RECOMBINATION

## Appendix A-5. Irrelevant Titles

7/8/402 (Item 73 from file: 34)

SciSearch(R) Cited Ref Sci

(c) 2010 The Thomson Corp. All rights reserved.

19534599 **Genuine Article#:** 476XG **Number of References:** 29

**Title:** Dispersion Stability Enhancement of Titania Nanoparticles in Organic Solvent Using a Bead Mill Process ( ABSTRACT AVAILABLE )

**Publication date:** 20090805

**Journal Subject Category:** ENGINEERING, CHEMICAL

**Identifiers:** KeyWord Plus(R): SURFACE; POLYMERIZATION; PARTICLES

7/8/403 (Item 74 from file: 34)

SciSearch(R) Cited Ref Sci

(c) 2010 The Thomson Corp. All rights reserved.

19524048 **Genuine Article#:** 478SY **Number of References:** 6

**Title:** Corrosion studies on the plasma-sprayed nanostructured titanium dioxide coatings ( ABSTRACT AVAILABLE )

**Publication date:** 20090000

**Journal Subject Category:** METALLURGY & METALLURGICAL ENGINEERING

**Descriptors:** SCIAuthor Keywords: Corrosion ; Plasma physics ; Nanotechnology ; Coatings

7/8/404 (Item 75 from file: 34)

SciSearch(R) Cited Ref Sci

(c) 2010 The Thomson Corp. All rights reserved.

19515294 **Genuine Article#:** 476FS **Number of References:** 45

**Title:** Mesoporous titania nanocrystals prepared using hexadecylamine surfactant template: Crystallization progress monitoring, morphological characterization and application in dye-sensitized solar cells ( ABSTRACT AVAILABLE )

**Publication date:** 20090800

**Journal Subject Category:** CHEMISTRY, APPLIED; CHEMISTRY, PHYSICAL; NANOSCIENCE & NANOTECHNOLOGY; MATERIALS SCIENCE, MULTIDISCIPLINARY

**Descriptors:** SCIAuthor Keywords: Mesoporous titania nanocrystals ; Hexadecylamine surfactant ; Dye-sensitized solar cells

**Identifiers:** KeyWord Plus(R): TIO2 FILMS; OXIDE; ELECTRODES; EFFICIENCY; PERFORMANCE; CONVERSION; NANOTUBES; LIGHT; SIZE; GELS

7/8/405 (Item 76 from file: 34)

SciSearch(R) Cited Ref Sci

(c) 2010 The Thomson Corp. All rights reserved.

19505342 **Genuine Article#:** 476KL **Number of References:** 32

**Title:** Nanochemistry aspects of titania in dye-sensitized solar cells ( ABSTRACT AVAILABLE )

**Publication date:** 20090000

## Appendix A-5. Irrelevant Titles

**Journal Subject Category:** CHEMISTRY, MULTIDISCIPLINARY; ENERGY & FUELS; ENGINEERING, CHEMICAL; ENVIRONMENTAL SCIENCES

**Identifiers:** KeyWord Plus(R): TIO2 NANOTUBE ARRAYS; PERFORMANCE; RECOMBINATION; TRANSPORT; EFFICIENCY; CONVERSION; ENERGY; LAYERS; LIGHT; FILMS

7/8/407 (Item 78 from file: 34)

SciSearch(R) Cited Ref Sci

(c) 2010 The Thomson Corp. All rights reserved.

19489381 **Genuine Article#:** 473MA **Number of References:** 22

**Title:** Preparation and pressureless sintering of nanostructured zirconia- titania composite powders ( ABSTRACT AVAILABLE )

**Publication date:** 20090000

**Journal Subject Category:** MATERIALS SCIENCE, MULTIDISCIPLINARY

**Descriptors:** SCIAuthor Keywords: ZrO<sub>2</sub>-Y<sub>2</sub>O<sub>3</sub>-TiO<sub>2</sub> ; crystallization ; nanocomposites ; pressureless sintering

**Identifiers:** KeyWord Plus(R): MICROSTRUCTURAL CHARACTERIZATION; NANOCRYSTALLINE CERAMICS; LOW-TEMPERATURE; NANOCOMPOSITES; STABILIZATION; CRYSTALLIZATION; BEHAVIOR; SYSTEM; ZRO2

7/8/408 (Item 79 from file: 34)

SciSearch(R) Cited Ref Sci

(c) 2010 The Thomson Corp. All rights reserved.

19489374 **Genuine Article#:** 473MA **Number of References:** 18

**Title:** Preparation and bioactivity of embedded-style hydroxyapatite-titania nanotube arrays ( ABSTRACT AVAILABLE )

**Publication date:** 20090000

**Journal Subject Category:** MATERIALS SCIENCE, MULTIDISCIPLINARY

**Descriptors:** SCIAuthor Keywords: hydroxyapatite ; bioactivity ; composite ; biomaterial ; nanotube array ; titania

**Identifiers:** KeyWord Plus(R): ANODIC-OXIDATION; POROUS TITANIUM; COATINGS; ELECTROLYTES; FABRICATION

7/8/409 (Item 80 from file: 34)

SciSearch(R) Cited Ref Sci

(c) 2010 The Thomson Corp. All rights reserved.

19487721 **Genuine Article#:** 472NI **Number of References:** 57

**Title:** Double-Wall Anodic Titania Nanotube Arrays for Water Photooxidation ( ABSTRACT AVAILABLE )

**Publication date:** 20090721

**Journal Subject Category:** CHEMISTRY, PHYSICAL

**Identifiers:** KeyWord Plus(R): SENSITIZED SOLAR-CELLS; HYDROGEN GENERATION; TIO2 PARTICLES; IONIC LIQUIDS; DOPED TIO2; DYE;

## Appendix A-5. Irrelevant Titles

FABRICATION; SEMICONDUCTOR; ANODIZATION; OXIDATION

7/8/411 (Item 82 from file: 34)

SciSearch(R) Cited Ref Sci

(c) 2010 The Thomson Corp. All rights reserved.

19469725 **Genuine Article#:** 473DA **Number of References:** 31

**Title:** {110}-exposed rutile titanium dioxide nanorods in photocatalytic performance ( ABSTRACT AVAILABLE )

**Publication date:** 20090000

**Journal Subject Category:** CHEMISTRY, MULTIDISCIPLINARY;  
CRYSTALLOGRAPHY

**Identifiers:** KeyWord Plus(R): LOW-TEMPERATURE SYNTHESIS; HYDROGEN-PEROXIDE; CRYSTALLINE PHASES; NANOSIZE RUTILE; TIO<sub>2</sub> NANORODS; LIQUID-MEDIA; ANATASE; NANOPARTICLES; DEGRADATION; REACTIVITY

7/8/413 (Item 84 from file: 34)

SciSearch(R) Cited Ref Sci

(c) 2010 The Thomson Corp. All rights reserved.

19448508 **Genuine Article#:** 470AN **Number of References:** 34

**Title:** Nanomechanical characterization of microwave hydrothermally synthesized titania nanowires ( ABSTRACT AVAILABLE )

**Publication date:** 20090721

**Journal Subject Category:** PHYSICS, APPLIED

**Identifiers:** KeyWord Plus(R): MECHANICAL-PROPERTIES; YOUNGS MODULUS; THIN-FILMS; SURFACE; NANOTUBES; DEPENDENCE; NANOBELTS; CATALYSTS; GROWTH; TIO<sub>2</sub>

7/8/414 (Item 85 from file: 34)

SciSearch(R) Cited Ref Sci

(c) 2010 The Thomson Corp. All rights reserved.

19424013 **Genuine Article#:** 463PU **Number of References:** 13

**Title:** Synthesis of mesoporous nanocrystalline titania powders by nonhydrolytic sol-gel method ( ABSTRACT AVAILABLE )

**Publication date:** 20090700

**Journal Subject Category:** PHYSICS, CONDENSED MATTER

**Descriptors:** SCIAuthor Keywords: Nonhydrolytic sol-gel ; Titania ; Anatase ; Mesoporosity ; Photocatalytic activity

**Identifiers:** KeyWord Plus(R): PHASE; TIO<sub>2</sub>; DIOXIDE

7/8/415 (Item 86 from file: 34)

SciSearch(R) Cited Ref Sci

(c) 2010 The Thomson Corp. All rights reserved.

## Appendix A-5. Irrelevant Titles

19411269 **Genuine Article#:** 465GW **Number of References:** 63

**Title:** Liquid phase deposition of titania onto nanostructured poly-p-xylylene thin films ( ABSTRACT AVAILABLE )

**Publication date:** 20090000

**Journal Subject Category:** CHEMISTRY, PHYSICAL; MATERIALS SCIENCE, MULTIDISCIPLINARY

**Identifiers:** KeyWord Plus(R): SELF-ASSEMBLED MONOLAYERS; ELECTROLESS METAL-DEPOSITION; POLY(P-XYLYLENE) FILMS; VAPOR-DEPOSITION; SELECTIVE DEPOSITION; SURFACE MODIFICATION; AQUEOUS-SOLUTION; ANATASE TIO<sub>2</sub>; DIOXIDE; ADHESION

7/8/416 (Item 87 from file: 34)

SciSearch(R) Cited Ref Sci

(c) 2010 The Thomson Corp. All rights reserved.

19405796 **Genuine Article#:** 464ND **Number of References:** 23

**Title:** NANOSTRUCTURE TITANIA REINFORCED CONDUCTING POLYMER COMPOSITES ( ABSTRACT AVAILABLE )

**Publication date:** 20090620

**Journal Subject Category:** PHYSICS, APPLIED; PHYSICS, CONDENSED MATTER; PHYSICS, MATHEMATICAL

**Descriptors:** SCIAuthor Keywords: Nanostructure ; titania ; nanocomposites ; polyaniline ; conducting polymers ; electrical conductivity

**Identifiers:** KeyWord Plus(R): TRANSPORT-PROPERTIES; ELECTRONIC TRANSPORT; POLYANILINE; BLENDS

7/8/417 (Item 88 from file: 34)

SciSearch(R) Cited Ref Sci

(c) 2010 The Thomson Corp. All rights reserved.

19389733 **Genuine Article#:** 466QA **Number of References:** 29

**Title:** Titania nanotubes supported platinum catalyst in CO oxidation process ( ABSTRACT AVAILABLE )

**Publication date:** 20090630

**Journal Subject Category:** CHEMISTRY, PHYSICAL; ENVIRONMENTAL SCIENCES

**Descriptors:** SCIAuthor Keywords: Titania nanotubes ; Platinum catalyst ; Carbon monoxide oxidation ; Metal-support interaction

**Identifiers:** KeyWord Plus(R): PT/TIO<sub>2</sub> CATALYSTS; AU NANOPARTICLES; TIO<sub>2</sub>; OXIDE; NANOFIBERS; MORPHOLOGY; NANOWIRES; AG

7/8/418 (Item 89 from file: 34)

SciSearch(R) Cited Ref Sci

(c) 2010 The Thomson Corp. All rights reserved.

19386486 **Genuine Article#:** 464VM **Number of References:** 38

**Title:** Patterned Production of Silver-Mesoporous Titania Nanocomposite Thin Films

## Appendix A-5. Irrelevant Titles

### **Using Lithography-Assisted Metal Reduction ( ABSTRACT AVAILABLE )**

**Publication date:** 20090400

**Journal Subject Category:** NANOSCIENCE & NANOTECHNOLOGY; MATERIALS SCIENCE, MULTIDISCIPLINARY

**Descriptors:** SCIAuthor Keywords: patterning ; metal nanoparticles ; mesoporous films ; UV lithography ; photodeposition

**Identifiers:** KeyWord Plus(R): AG NANOPARTICLES; GOLD NANOPARTICLES; TIO2 FILMS; SILICA; ARRAYS; PHOTOCATALYSIS; DEPOSITION; ANATASE; MULTILAYER; SUBSTRATE

7/8/419 (Item 90 from file: 34)

SciSearch(R) Cited Ref Sci

(c) 2010 The Thomson Corp. All rights reserved.

19383525 **Genuine Article#:** 461YK **Number of References:** 30

**Title:** Citrate-nitrate synthesis of nano-structured titanium dioxide ceramics for gas sensors ( ABSTRACT AVAILABLE )

**Publication date:** 20090618

**Journal Subject Category:** CHEMISTRY, ANALYTICAL; ELECTROCHEMISTRY; INSTRUMENTS & INSTRUMENTATION

**Descriptors:** SCIAuthor Keywords: TiO2 ; Citrate-nitrate ; Gas sensor ; Yttrium

**Identifiers:** KeyWord Plus(R): SOL-GEL PROCESS; THIN-FILMS; TEMPERATURE SYNTHESIS; CARBON-MONOXIDE; OXIDES; TIO2; ALPHA-FE2O3; POWDERS

7/8/423 (Item 94 from file: 34)

SciSearch(R) Cited Ref Sci

(c) 2010 The Thomson Corp. All rights reserved.

19348322 **Genuine Article#:** 457XF **Number of References:** 51

**Title:** Comparative Photoactivity and Antibacterial Properties of C-60 Fullerenes and Titanium Dioxide Nanoparticles ( ABSTRACT AVAILABLE )

**Publication date:** 20090615

**Journal Subject Category:** ENGINEERING, ENVIRONMENTAL; ENVIRONMENTAL SCIENCES

**Identifiers:** KeyWord Plus(R): SINGLET MOLECULAR-OXYGEN; WATER-SOLUBLE FULLERENES; ESCHERICHIA-COLI; OXIDATIVE STRESS; TIO2 PARTICLES; INACTIVATION; SUSPENSIONS; MECHANISM; DAMAGE; NANOMATERIALS

7/8/424 (Item 95 from file: 34)

SciSearch(R) Cited Ref Sci

(c) 2010 The Thomson Corp. All rights reserved.

19346809 **Genuine Article#:** 458UE **Number of References:** 38

**Title:** Low-Temperature Synthesis of Mesoporous Titania-Silica Films with Pre-Formed Anatase Nanocrystals ( ABSTRACT AVAILABLE )

**Publication date:** 20090623

**Journal Subject Category:** CHEMISTRY, PHYSICAL; MATERIALS SCIENCE,

## Appendix A-5. Irrelevant Titles

### MULTIDISCIPLINARY

**Identifiers:** KeyWord Plus(R): SUPPORTED TIO2 PHOTOCATALYSTS; METAL-OXIDE NANOPARTICLES; SOL-GEL PROCESS; THIN-FILMS; NONAQUEOUS SYNTHESIS; CRYSTALLINE; RAMAN; NANOCOMPOSITE; SPECTROSCOPY; MECHANISMS

7/8/425 (Item 96 from file: 34)

SciSearch(R) Cited Ref Sci

(c) 2010 The Thomson Corp. All rights reserved.

19324511 **Genuine Article#:** 456SM **Number of References:** 46

**Title:** **Contrasting properties of gold nanoshells and titanium dioxide nanoparticles for optical coherence tomography imaging of skin: Monte Carlo simulations and in vivo study** ( ABSTRACT AVAILABLE )

**Publication date:** 20090300

**Journal Subject Category:** BIOCHEMICAL RESEARCH METHODS; OPTICS; RADIOLOGY, NUCLEAR MEDICINE & MEDICAL IMAGING

**Descriptors:** SCIAuthor Keywords: optical coherence tomography ; skin ; nanoparticles ; contrasting ; Monte Carlo simulations

**Identifiers:** KeyWord Plus(R): REFRACTIVE-INDEX; SCATTERING; THERAPY; TISSUES; CANCER; AGENTS; PARTICLES; CELLS

7/8/426 (Item 97 from file: 34)

SciSearch(R) Cited Ref Sci

(c) 2010 The Thomson Corp. All rights reserved.

19304275 **Genuine Article#:** 453VN **Number of References:** 28

**Title:** **Hybrid poly (3-hexylthiophene)/titanium dioxide nanorods material for solar cell applications** ( ABSTRACT AVAILABLE )

**Publication date:** 20090600

**Journal Subject Category:** ENERGY & FUELS; MATERIALS SCIENCE, MULTIDISCIPLINARY

**Descriptors:** SCIAuthor Keywords: Titanium dioxide ; Nanorod ; Poly(3-hexylthiophene) ; Solar cell ; Hybrid ; Kelvin probe force microscopy

**Identifiers:** KeyWord Plus(R): PHOTOINDUCED CHARGE-TRANSFER; PHOTOVOLTAIC DEVICES; REGIOREGULAR POLY(3-HEXYLTHIOPHENE); MORPHOLOGY; NANOCOMPOSITES; COMPOSITES; MOBILITY; NETWORK; BLEND; FILMS

7/8/427 (Item 98 from file: 34)

SciSearch(R) Cited Ref Sci

(c) 2010 The Thomson Corp. All rights reserved.

19296241 **Genuine Article#:** 453FQ **Number of References:** 19

**Title:** **Influence of Different Sizes of Titanium Dioxide Nanoparticles on Hepatic and**

## Appendix A-5. Irrelevant Titles

**Renal Functions in Rats with Correlation to Oxidative Stress** ( ABSTRACT AVAILABLE )

**Publication date:** 20090000

**Journal Subject Category:** ENVIRONMENTAL SCIENCES; PUBLIC, ENVIRONMENTAL & OCCUPATIONAL HEALTH; TOXICOLOGY

**Identifiers:** KeyWord Plus(R): SUBCHRONIC INHALATION; PULMONARY RESPONSES; ULTRAFINE TIO<sub>2</sub>; SURFACE-AREA; PARTICLES; TOXICITY; CELLS; FINE; MICE; CYTOTOXICITY

7/8/428 (Item 99 from file: 34)

SciSearch(R) Cited Ref Sci

(c) 2010 The Thomson Corp. All rights reserved.

19293417 **Genuine Article#:** 453MX **Number of References:** 23

**Title: Ethanol vapor processing of titania nanotube array films: enhanced crystallization and photoelectrochemical performance** ( ABSTRACT AVAILABLE )

**Publication date:** 20090000

**Journal Subject Category:** CHEMISTRY, PHYSICAL; MATERIALS SCIENCE, MULTIDISCIPLINARY

**Identifiers:** KeyWord Plus(R): SOLVOTHERMAL SYNTHESIS; TIO<sub>2</sub> NANOTUBES; SOLAR-CELLS; NANOPARTICLES; OXIDATION; GROWTH; LENGTH

7/8/429 (Item 100 from file: 34)

SciSearch(R) Cited Ref Sci

(c) 2010 The Thomson Corp. All rights reserved.

19283543 **Genuine Article#:** 453BN **Number of References:** 39

**Title: Laboratory studies and CFD modeling of photocatalytic degradation of colored textile wastewater by titania nanoparticles** ( ABSTRACT AVAILABLE )

**Publication date:** 20090100

**Journal Subject Category:** ENGINEERING, CHEMICAL; WATER RESOURCES

**Descriptors:** SCIAuthor Keywords: Photocatalysis ; CFD modeling ; Decolorization ; Mineralization ; Titania nanoparticle

**Identifiers:** KeyWord Plus(R): IMMOBILIZED TIO<sub>2</sub>; METHYLENE-BLUE; AZO-DYE; OPERATIONAL PARAMETERS; HYDROGEN-PEROXIDE; REACTIVE RED-198; AQUEOUS-SOLUTION; DECOLORIZATION; ADSORPTION; OXIDATION

7/8/431 (Item 102 from file: 34)

SciSearch(R) Cited Ref Sci

(c) 2010 The Thomson Corp. All rights reserved.

19259952 **Genuine Article#:** 451YU **Number of References:** 24

**Title: In vivo acute toxicity of titanium dioxide nanoparticles to mice after intraperitoneal injection** ( ABSTRACT AVAILABLE )

**Publication date:** 20090500

**Journal Subject Category:** TOXICOLOGY

## Appendix A-5. Irrelevant Titles

**Descriptors:** SCIAuthor Keywords: acute **toxicity** ; nano-sized TiO<sub>2</sub> particle ; mice ; titanium content ; histopathological examination ; intraperitoneal injection

**Identifiers:** KeyWord Plus(R): SUBCHRONIC INHALATION; PULMONARY RESPONSES; PARTICLES; NANOMATERIALS; RATS; TIO<sub>2</sub>

7/8/432 (Item 103 from file: 34)

SciSearch(R) Cited Ref Sci

(c) 2010 The Thomson Corp. All rights reserved.

19254659 **Genuine Article#:** 451XO **Number of References:** 34

**Title:** Comparison of various anodization and annealing conditions of titanium dioxide nanotubular film on MB degradation ( ABSTRACT AVAILABLE )

**Publication date:** 20090700

**Journal Subject Category:** PHYSICS, APPLIED

**Identifiers:** KeyWord Plus(R): SENSITIZED SOLAR-CELLS; ANODIC TIO<sub>2</sub> NANOTUBES; ARRAYS; PHOTOCATALYSIS; FABRICATION; SURFACES; RATIO; GLASS

7/8/433 (Item 104 from file: 34)

SciSearch(R) Cited Ref Sci

(c) 2010 The Thomson Corp. All rights reserved.

19244755 **Genuine Article#:** 449IH **Number of References:** 76

**Title:** Construction of Highly Ordered Lamellar Nanostructures through Langmuir-Blodgett Deposition of Molecularly Thin Titania Nanosheets Tens of Micrometers Wide and Their Excellent Dielectric Properties ( ABSTRACT AVAILABLE )

**Publication date:** 20090500

**Journal Subject Category:** CHEMISTRY, MULTIDISCIPLINARY; NANOSCIENCE & NANOTECHNOLOGY; MATERIALS SCIENCE, MULTIDISCIPLINARY

**Descriptors:** SCIAuthor Keywords: nanosheet ; Langmuir-Blodgett procedure ; layer-by-layer deposition ; multilayer film ; dielectric properties

**Identifiers:** KeyWord Plus(R): MANGANESE OXIDE NANOSHEETS; MULTILAYER ULTRATHIN FILMS; LAYERED TITANATE; VISIBLE-LIGHT; FABRICATION; EXFOLIATION; PHOSPHOR; DIOXIDE; GROWTH; PHOTOLUMINESCENCE

7/8/434 (Item 105 from file: 34)

SciSearch(R) Cited Ref Sci

(c) 2010 The Thomson Corp. All rights reserved.

19233579 **Genuine Article#:** 446KY **Number of References:** 26

**Title:** Photocatalytic inactivation of Bacillus anthracis by titania nanomaterials ( ABSTRACT AVAILABLE )

**Publication date:** 20090615

**Journal Subject Category:** ENGINEERING, ENVIRONMENTAL; ENGINEERING, CIVIL; ENVIRONMENTAL SCIENCES

## Appendix A-5. Irrelevant Titles

**Descriptors:** SCIAuthor Keywords: Photocatalysis ; Bacillus anthracis ; Nanosized titania ; Inactivation

**Identifiers:** KeyWord Plus(R): ESCHERICHIA-COLI; WATER; TIO<sub>2</sub>; STERILIZATION; CHLORINATION; DISINFECTION; POWDERS; LIGHT

7/8/435 (Item 106 from file: 34)

SciSearch(R) Cited Ref Sci

(c) 2010 The Thomson Corp. All rights reserved.

19231317 **Genuine Article#:** 448SQ **Number of References:** 60

**Title:** Crystallite phase-controlled preparation, characterisation and photocatalytic properties of titanium dioxide nanoparticles ( ABSTRACT AVAILABLE )

**Publication date:** 20090000

**Journal Subject Category:** CHEMISTRY, MULTIDISCIPLINARY; NANOSCIENCE & NANOTECHNOLOGY; MATERIALS SCIENCE, MULTIDISCIPLINARY; PHYSICS, APPLIED

**Descriptors:** SCIAuthor Keywords: nanoparticles ; nano-TiO<sub>2</sub> ; photocatalyst ; nanocatalyst ; advanced oxidation processes

**Identifiers:** KeyWord Plus(R): CHEMICAL-VAPOR-DEPOSITION; COMBUSTION-SYNTHESIZED TIO<sub>2</sub>; SOL-GEL SYNTHESIS; NANOSIZED TIO<sub>2</sub>; NANOCRYSTALLINE TIO<sub>2</sub>; HYDROTHERMAL SYNTHESIS; REVERSE MICROEMULSION; PLASMA EVAPORATION; ORGANIC-COMPOUNDS; SURFACE SCIENCE

7/8/436 (Item 107 from file: 34)

SciSearch(R) Cited Ref Sci

(c) 2010 The Thomson Corp. All rights reserved.

19224308 **Genuine Article#:** 447KO **Number of References:** 32

**Title:** Using the Box-Benkhen technique to statistically model phenol photocatalytic degradation by titanium dioxide nanoparticles ( ABSTRACT AVAILABLE )

**Publication date:** 20090715

**Journal Subject Category:** ENGINEERING, CHEMICAL

**Descriptors:** SCIAuthor Keywords: Photocatalysis ; Maximization ; Titanium dioxide ; Box-Benkhen design

**Identifiers:** KeyWord Plus(R): HETEROGENEOUS PHOTOCATALYSIS; WASTE-WATER; TIO<sub>2</sub>; OXIDATION; CONTAMINANTS; OPTIMIZATION; DESTRUCTION; MECHANISMS; REMOVAL

7/8/437 (Item 108 from file: 34)

SciSearch(R) Cited Ref Sci

(c) 2010 The Thomson Corp. All rights reserved.

19224264 **Genuine Article#:** 448NQ **Number of References:** 17

**Title:** Design of hybrid titania nanocrystallites as supports for gold catalysts ( ABSTRACT AVAILABLE )

**Publication date:** 20090000

## Appendix A-5. Irrelevant Titles

**Journal Subject Category:** CHEMISTRY, MULTIDISCIPLINARY

**Identifiers:** KeyWord Plus(R): OXIDATION; TIO<sub>2</sub>; CO; EPOXIDATION; MECHANISM; STILBENE

7/8/438 (Item 109 from file: 34)

SciSearch(R) Cited Ref Sci

(c) 2010 The Thomson Corp. All rights reserved.

19211485 **Genuine Article#:** 442PV **Number of References:** 35

**Title:** In situ investigation of molecular kinetics and particle formation of water-dispersible titania nanocrystals ( ABSTRACT AVAILABLE )

**Publication date:** 20090000

**Journal Subject Category:** CHEMISTRY, PHYSICAL; PHYSICS, ATOMIC, MOLECULAR & CHEMICAL

**Identifiers:** KeyWord Plus(R): METAL-OXIDE NANOPARTICLES; VERSATILE REACTION SYSTEM; NONAQUEOUS SYNTHESIS; BENZYL ALCOHOL; SURFACE; TIO<sub>2</sub>; FUNCTIONALIZATION; CRYSTALLINE; ROUTES

7/8/439 (Item 110 from file: 34)

SciSearch(R) Cited Ref Sci

(c) 2010 The Thomson Corp. All rights reserved.

19211481 **Genuine Article#:** 442PV **Number of References:** 51

**Title:** Blue nano titania made in diffusion flames ( ABSTRACT AVAILABLE )

**Publication date:** 20090000

**Journal Subject Category:** CHEMISTRY, PHYSICAL; PHYSICS, ATOMIC, MOLECULAR & CHEMICAL

**Identifiers:** KeyWord Plus(R): TIO<sub>2</sub> PARTICLES; PHOTOCATALYTIC ACTIVITY; TIO<sub>2</sub>(110) SURFACES; MAGNELI PHASES; OXYGEN SYSTEM; NANOPARTICLES; RUTILE; POWDERS; DIOXIDE; ANATASE

7/8/440 (Item 111 from file: 34)

SciSearch(R) Cited Ref Sci

(c) 2010 The Thomson Corp. All rights reserved.

19211126 **Genuine Article#:** 443DL **Number of References:** 12

**Title:** Effect of the conditions of platinum deposition on titania nanocrystalline films on the efficiency of photocatalytic oxidation of ethanol and production of hydrogen ( ABSTRACT AVAILABLE )

**Publication date:** 20090000

**Journal Subject Category:** BIOCHEMISTRY & MOLECULAR BIOLOGY; BIOPHYSICS; CHEMISTRY, PHYSICAL

**Identifiers:** KeyWord Plus(R): ALCOHOL; WATER

7/8/441 (Item 112 from file: 34)

## Appendix A-5. Irrelevant Titles

SciSearch(R) Cited Ref Sci

(c) 2010 The Thomson Corp. All rights reserved.

19190288 **Genuine Article#:** 445TO **Number of References:** 18

**Title: Correlating Photoluminescence and Photocatalytic Activity of Mixed-phase Nanocrystalline Titania** ( ABSTRACT AVAILABLE )

**Publication date:** 20090600

**Journal Subject Category:** CHEMISTRY, PHYSICAL

**Descriptors:** SCIAuthor Keywords: Nanocrystalline ; Photocatalytic activity ; Photoluminescence ; Sol-gel ; Titania

**Identifiers:** KeyWord Plus(R): SOL-GEL; TIO<sub>2</sub>; DIOXIDE; WATER; FILM

7/8/442 (Item 113 from file: 34)

SciSearch(R) Cited Ref Sci

(c) 2010 The Thomson Corp. All rights reserved.

19177931 **Genuine Article#:** 438BC **Number of References:** 43

**Title: Mechanistic Insight by in Situ FTIR for the Gas Phase Photo-oxidation of Ethylene by V-Doped Titania and Nano Titania** ( ABSTRACT AVAILABLE )

**Publication date:** 20090430

**Journal Subject Category:** CHEMISTRY, PHYSICAL

**Identifiers:** KeyWord Plus(R): QUANTUM-SIZED TIO<sub>2</sub>; METAL-ION DOPANTS; VANADIA-TITANIA; OXIDE CATALYSTS; FLOW REACTOR; MIXED OXIDES; OXIDATION; SURFACE; IR; REACTIVITY

7/8/443 (Item 114 from file: 34)

SciSearch(R) Cited Ref Sci

(c) 2010 The Thomson Corp. All rights reserved.

19172836 **Genuine Article#:** 441PK **Number of References:** 71

**Title: A Novel Method for Synthesis of Titania Nanotube Powders using Rapid Breakdown Anodization** ( ABSTRACT AVAILABLE )

**Publication date:** 20090512

**Journal Subject Category:** CHEMISTRY, PHYSICAL; MATERIALS SCIENCE, MULTIDISCIPLINARY

**Identifiers:** KeyWord Plus(R): SENSITIZED SOLAR-CELLS; ULTRAHIGH-ASPECT-RATIO; CARBON-DOPED TITANIA; TIO<sub>2</sub> NANOTUBES; OXIDE NANOTUBE; PHOTOCATALYTIC ACTIVITY; POROUS TIO<sub>2</sub>; ARRAYS; ELECTROLYTES; FLUORIDE

7/8/444 (Item 115 from file: 34)

SciSearch(R) Cited Ref Sci

(c) 2010 The Thomson Corp. All rights reserved.

19167141 **Genuine Article#:** 438AC **Number of References:** 12

**Title: SURFACE MODIFICATION OF POLYETHYLENE (PE) BY THE**

## Appendix A-5. Irrelevant Titles

### **DEPOSITION OF TITANIUM DIOXIDE (TiO<sub>2</sub>) NANOPARTICLES TO ENHANCE THE PHOTOCATALYTIC ACTIVITIES ( ABSTRACT AVAILABLE )**

**Publication date:** 20090400

**Journal Subject Category:** CHEMISTRY, PHYSICAL; PHYSICS, CONDENSED MATTER

**Descriptors:** SCIAuthor Keywords: Titanium dioxide (TiO<sub>2</sub>) ; photodegradation ; polyethylene ; particle deposition ; surface modification

**Identifiers:** KeyWord Plus(R): DEGRADATION; FILM

7/8/445 (Item 116 from file: 34)

SciSearch(R) Cited Ref Sci

(c) 2010 The Thomson Corp. All rights reserved.

19154146 **Genuine Article#:** 435ZV **Number of References:** 79

**Title:** Titania Nanofilm with Electrical Switching Effects upon Hydrogen/Air Exposure at Room Temperature ( ABSTRACT AVAILABLE )

**Publication date:** 20090423

**Journal Subject Category:** CHEMISTRY, PHYSICAL; NANOSCIENCE & NANOTECHNOLOGY; MATERIALS SCIENCE, MULTIDISCIPLINARY

**Identifiers:** KeyWord Plus(R): ATOMIC LAYER DEPOSITION; GAS-SENSING PROPERTIES; SEMICONDUCTIVE THIN FILMS; SENSITIZED SOLAR-CELLS; TIO<sub>2</sub> NANOTUBE ARRAYS; METAL-OXIDES; GASEOUS COMPONENTS; NANOWIRE ARRAYS; SELECTIVE DETECTION; CHEMICAL SENSORS

7/8/446 (Item 117 from file: 34)

SciSearch(R) Cited Ref Sci

(c) 2010 The Thomson Corp. All rights reserved.

19144139 **Genuine Article#:** 436KG **Number of References:** 48

**Title:** Improving the Photocatalytic Performance of Mesoporous Titania Films by Modification with Gold Nanostructures ( ABSTRACT AVAILABLE )

**Publication date:** 20090428

**Journal Subject Category:** CHEMISTRY, PHYSICAL; MATERIALS SCIENCE, MULTIDISCIPLINARY

**Identifiers:** KeyWord Plus(R): THIN-FILMS; METAL NANOPARTICLES; OPTICAL-PROPERTIES; ROOM-TEMPERATURE; TIO<sub>2</sub> FILMS; OXIDATION; AU; NANOCOMPOSITES; NANOCRYSTALS; DEPOSITION

7/8/447 (Item 118 from file: 34)

SciSearch(R) Cited Ref Sci

(c) 2010 The Thomson Corp. All rights reserved.

19134632 **Genuine Article#:** 435EM **Number of References:** 15

**Title:** Magnetoswitchable controlled photocatalytic system using ferromagnetic Fe-0-doped titania nanorods photocatalysts with enhanced photoactivity ( ABSTRACT AVAILABLE )

**Publication date:** 20090407

## Appendix A-5. Irrelevant Titles

**Journal Subject Category:** ENGINEERING, CHEMICAL

**Descriptors:** SCIAuthor Keywords: Titania nanorods ; Fe-0 ; Photoactivity ; Ferromagnetic property ; Magnetoswitchable

**Identifiers:** KeyWord Plus(R): NANOTUBES; TIO2; DEGRADATION; REDUCTION; IONS; FE

7/8/448 (Item 119 from file: 34)

SciSearch(R) Cited Ref Sci

(c) 2010 The Thomson Corp. All rights reserved.

19127119 **Genuine Article#:** 434TZ **Number of References:** 31

**Title:** Photoelectrochemical behavior of titania nanotube array grown on nanocrystalline titanium ( ABSTRACT AVAILABLE )

**Publication date:** 20090600

**Journal Subject Category:** MATERIALS SCIENCE, MULTIDISCIPLINARY

**Identifiers:** KeyWord Plus(R): SENSITIZED SOLAR-CELLS; OXIDE FILMS; ANODIC-OXIDATION; TIO2 NANOTUBES; ANODIZATION; NANOSTRUCTURES; SMAT; ELECTRODES; MECHANISM

7/8/449 (Item 120 from file: 34)

SciSearch(R) Cited Ref Sci

(c) 2010 The Thomson Corp. All rights reserved.

19085046 **Genuine Article#:** 430UQ **Number of References:** 37

**Title:** Colloidal suspensions of clay or titanium dioxide nanoparticles can inhibit leaf growth and transpiration via physical effects on root water transport ( ABSTRACT AVAILABLE )

**Publication date:** 20090500

**Journal Subject Category:** PLANT SCIENCES

**Descriptors:** SCIAuthor Keywords: bentonite ; cell walls ; hydraulic conductivity ; pore size ; root clogging ; TiO2

**Identifiers:** KeyWord Plus(R): PARTICLE SURFACE CHARACTERISTICS; CELL-WALLS; ALUMINA NANOPARTICLES; SIZE DISTRIBUTION; PORE-SIZE; POROSITY; MAIZE; XYLEM; SOIL; MEMBRANE

7/8/450 (Item 121 from file: 34)

SciSearch(R) Cited Ref Sci

(c) 2010 The Thomson Corp. All rights reserved.

19078503 **Genuine Article#:** 427PY **Number of References:** 23

**Title:** Synthesis of Titania Nanosheets with a High Percentage of Exposed (001) Facets and Related Photocatalytic Properties ( ABSTRACT AVAILABLE )

**Publication date:** 20090311

**Journal Subject Category:** CHEMISTRY, MULTIDISCIPLINARY

**Identifiers:** KeyWord Plus(R): SURFACE SCIENCE; TIO2; NANOCRYSTALS;

## Appendix A-5. Irrelevant Titles

ANATASE; CHEMISTRY; MECHANISM; CRYSTALS; NANORODS; DIOXIDE;  
WATER

7/8/451 (Item 122 from file: 34)

SciSearch(R) Cited Ref Sci

(c) 2010 The Thomson Corp. All rights reserved.

19074948 **Genuine Article#:** 430ZD **Number of References:** 46

**Title:** Comparing Ultraviolet and Chemical Reduction Techniques for Enhancing Photocatalytic Activity of Silver Oxide/Silver Deposited Nanocrystalline Anatase Titania ( ABSTRACT AVAILABLE )

**Publication date:** 20090416

**Journal Subject Category:** CHEMISTRY, PHYSICAL; NANOSCIENCE & NANOTECHNOLOGY; MATERIALS SCIENCE, MULTIDISCIPLINARY

**Identifiers:** KeyWord Plus(R): NEGATIVE-ION IMPLANTATION; SOL-GEL; THIN-FILMS; TIO2 PHOTOCATALYST; INORGANIC ANIONS; AQUEOUS-SOLUTION; METHYLENE-BLUE; AZO-DYE; PARTICLES; NANOPARTICLES

7/8/453 (Item 124 from file: 34)

SciSearch(R) Cited Ref Sci

(c) 2010 The Thomson Corp. All rights reserved.

19060775 **Genuine Article#:** 428EI **Number of References:** 25

**Title:** Hierarchical Titanate Nanostructures through Hydrothermal Treatment of Commercial Titania Powders ( ABSTRACT AVAILABLE )

**Publication date:** 20090000

**Journal Subject Category:** CHEMISTRY, INORGANIC & NUCLEAR

**Descriptors:** SCIAuthor Keywords: Hydrothermal synthesis ; Nanostructures ; Nanowire arrays ; Titanates

**Identifiers:** KeyWord Plus(R): LAYERED TITANATES; ION-EXCHANGE; NANOWIRE ARRAYS; TIO2 B; NANOTUBES; NA2TI3O7; WATER

7/8/454 (Item 125 from file: 34)

SciSearch(R) Cited Ref Sci

(c) 2010 The Thomson Corp. All rights reserved.

19059785 **Genuine Article#:** 426EX **Number of References:** 39

**Title:** Sulfonated polyaniline-titanium dioxide nanocomposites synthesized by one-pot UV-curable polymerization method ( ABSTRACT AVAILABLE )

**Publication date:** 20090200

**Journal Subject Category:** MATERIALS SCIENCE, MULTIDISCIPLINARY; PHYSICS, CONDENSED MATTER; POLYMER SCIENCE

**Descriptors:** SCIAuthor Keywords: UV-curable polymerization method ; Sulfonated polyaniline ; Titanium dioxide nanocomposites

**Identifiers:** KeyWord Plus(R): CONDUCTING POLYANILINE; TIO2 NANOPARTICLES; AQUEOUS-SOLUTION; COMPOSITES; ROUTE; FILMS;

## Appendix A-5. Irrelevant Titles

IRRADIATION; DERIVATIVES; FABRICATION; NANOTUBES

7/8/455 (Item 126 from file: 34)

SciSearch(R) Cited Ref Sci

(c) 2010 The Thomson Corp. All rights reserved.

19042751 **Genuine Article#:** 427MF **Number of References:** 43

**Title:** Influence of titanium dioxide nanoparticles on speciation and bioavailability of arsenite ( ABSTRACT AVAILABLE )

**Publication date:** 20090400

**Journal Subject Category:** ENVIRONMENTAL SCIENCES

**Descriptors:** SCIAuthor Keywords: Arsenic ; TiO<sub>2</sub> ; Nanoparticles ; Bioaccumulation ; Carp ; Facilitated **transport**

**Identifiers:** KeyWord Plus(R): ULTRAFINE PARTICLES; ADSORPTION; DRUGS; BIOACCUMULATION; GEOCHEMISTRY; ACCUMULATION; SUSPENSIONS; TRANSPORT; EXPOSURE; ARSENATE

7/8/457 (Item 128 from file: 34)

SciSearch(R) Cited Ref Sci

(c) 2010 The Thomson Corp. All rights reserved.

19041265 **Genuine Article#:** 427SA **Number of References:** 43

**Title:** Optimization of Silica Content in Initial Sol-Gel Grain Particles for the Low Temperature Hydrothermal Synthesis of Titania Nanotubes ( ABSTRACT AVAILABLE )

**Publication date:** 20090400

**Journal Subject Category:** CHEMISTRY, MULTIDISCIPLINARY; CRYSTALLOGRAPHY; MATERIALS SCIENCE, MULTIDISCIPLINARY

**Identifiers:** KeyWord Plus(R): RAMAN-SCATTERING; NANOPHASE TIO<sub>2</sub>; SIZE QUANTIZATION; DIOXIDE; WATER; PHOTOLUMINESCENCE; SEMICONDUCTOR; NANOCRYSTALS; OXIDATION; SCIENCE

7/8/458 (Item 129 from file: 34)

SciSearch(R) Cited Ref Sci

(c) 2010 The Thomson Corp. All rights reserved.

19029014 **Genuine Article#:** 425LV **Number of References:** 31

**Title:** The size dependence of the surface free energy of titania nanocrystals ( ABSTRACT AVAILABLE )

**Publication date:** 20090000

**Journal Subject Category:** CHEMISTRY, PHYSICAL; PHYSICS, ATOMIC, MOLECULAR & CHEMICAL

**Identifiers:** KeyWord Plus(R): AMORPHOUS TITANIA; PHASE-STABILITY; PARTICLE-SIZE; ANATASE TIO<sub>2</sub>; STRESS; TEMPERATURE; KINETICS; TENSION;

## Appendix A-5. Irrelevant Titles

### GROWTH

7/8/460 (Item 131 from file: 34)

SciSearch(R) Cited Ref Sci

(c) 2010 The Thomson Corp. All rights reserved.

18993800 **Genuine Article#:** 421VH **Number of References:** 30

**Title:** Effect of process parameters on the chemical vapour synthesis of nanocrystalline titania (vol 41, 155313, 2008)

**Publication date:** 20090407

**Journal Subject Category:** PHYSICS, APPLIED

**Identifiers:** KeyWord Plus(R): THERMODYNAMIC ANALYSIS; TIO2; POWDERS; NANOPARTICLE; CONDENSATION; TEMPERATURE; REACTOR; FILMS

7/8/461 (Item 132 from file: 34)

SciSearch(R) Cited Ref Sci

(c) 2010 The Thomson Corp. All rights reserved.

18993613 **Genuine Article#:** 422DY **Number of References:** 41

**Title:** Synthesis of highly active H2O2-sensitized sulfated titania nanoparticles with a response to visible light ( ABSTRACT AVAILABLE )

**Publication date:** 20090225

**Journal Subject Category:** CHEMISTRY, PHYSICAL

**Descriptors:** SCIAuthor Keywords: Sulfated TiO2 ; Hydrogen peroxide ; Visible light ; Surface acidity

**Identifiers:** KeyWord Plus(R): PHOTOCATALYTIC DEGRADATION; HYDROGEN-PEROXIDE; PHENOL DEGRADATION; TIO2; H2O2; OXIDATION; REDUCTION; O-2(CENTER-DOT-); TEMPERATURE; SUSPENSIONS

7/8/462 (Item 133 from file: 34)

SciSearch(R) Cited Ref Sci

(c) 2010 The Thomson Corp. All rights reserved.

18992311 **Genuine Article#:** 418PH **Number of References:** 14

**Title:** Photodegradation of the herbicide azimsulfuron using nanocrystalline titania films as photocatalyst and low intensity Black Light radiation or simulated solar radiation as excitation source ( ABSTRACT AVAILABLE )

**Publication date:** 20090430

**Journal Subject Category:** ENGINEERING, ENVIRONMENTAL; ENGINEERING, CIVIL; ENVIRONMENTAL SCIENCES

**Descriptors:** SCIAuthor Keywords: Azimsulfuron ; Heterogeneous Photocatalysis ; Titania

**Identifiers:** KeyWord Plus(R): ADVANCED OXIDATION PROCESSES; AQUEOUS-SOLUTIONS; PHOTO-FENTON; DEGRADATION; TIO2; WATER; DYES

7/8/463 (Item 134 from file: 34)

## Appendix A-5. Irrelevant Titles

SciSearch(R) Cited Ref Sci

(c) 2010 The Thomson Corp. All rights reserved.

18991871 **Genuine Article#:** 421TT **Number of References:** 26

**Title: Evaluation of the adsorption potential of titanium dioxide nanoparticles for arsenic removal ( ABSTRACT AVAILABLE )**

**Publication date:** 20090000

**Journal Subject Category:** ENVIRONMENTAL SCIENCES

**Descriptors:** SCIAuthor Keywords: arsenic removal ; titanium dioxide nanoparticles ; adsorption isotherm ; immobilization of nanoparticles on sand

**Identifiers:** KeyWord Plus(R): PHOTOCATALYTIC OXIDATION; AQUEOUS-SOLUTION; GROUNDWATER; FERRIHYDRITE; EQUILIBRIUM; KINETICS; AS(III); AS(V); IRON

7/8/464 (Item 135 from file: 34)

SciSearch(R) Cited Ref Sci

(c) 2010 The Thomson Corp. All rights reserved.

18985682 **Genuine Article#:** 420DF **Number of References:** 35

**Title: Photocatalytic properties of nanocrystalline titanium dioxide films in the degradation of domoic acid in aqueous solution: potential for use in molluscan shellfish biotoxin depuration facilities ( ABSTRACT AVAILABLE )**

**Publication date:** 20090000

**Journal Subject Category:** CHEMISTRY, APPLIED; FOOD SCIENCE & TECHNOLOGY; TOXICOLOGY

**Descriptors:** SCIAuthor Keywords: domoic acid ; low temperature crystallization ; nanocrystalline titanium dioxide ; thin film ; photocatalytic activity ; photodegradation mechanism

**Identifiers:** KeyWord Plus(R): TIO2 THIN-FILMS; PSEUDO-NITZSCHIA; PHOTODEGRADATION; IDENTIFICATION; MUSSELS; GLASS

7/8/465 (Item 136 from file: 34)

SciSearch(R) Cited Ref Sci

(c) 2010 The Thomson Corp. All rights reserved.

18981877 **Genuine Article#:** 422OL **Number of References:** 18

**Title: Photocatalytic activity of iron doped nanocrystalline titania for the oxidative degradation of 2,4,6-trichlorophenol ( ABSTRACT AVAILABLE )**

**Publication date:** 20090315

**Journal Subject Category:** CHEMISTRY, APPLIED; CHEMISTRY, PHYSICAL; ENGINEERING, CHEMICAL

**Descriptors:** SCIAuthor Keywords: Photocatalysis ; Nanocrystalline titania ; UV-Vis DRS ; Trichlorophenol

**Identifiers:** KeyWord Plus(R): SEMICONDUCTOR PHOTOCATALYSIS; AQUEOUS SUSPENSION; TIO2; WATER; 2-CHLOROPHENOL; REACTIVITY

## Appendix A-5. Irrelevant Titles

7/8/466 (Item 137 from file: 34)

SciSearch(R) Cited Ref Sci

(c) 2010 The Thomson Corp. All rights reserved.

18981865 **Genuine Article#:** 422OL **Number of References:** 28

**Title:** Photocatalytic mineralization of benzene over gold containing titania nanotubes: Role of adsorbed water and nanosize gold crystallites ( ABSTRACT AVAILABLE )

**Publication date:** 20090315

**Journal Subject Category:** CHEMISTRY, APPLIED; CHEMISTRY, PHYSICAL; ENGINEERING, CHEMICAL

**Descriptors:** SCIAuthor Keywords: TiO<sub>2</sub> nanotubes ; Gold containing ; Photocatalyst ; Benzene degradation ; Role of adsorbed water ; Transient species

**Identifiers:** KeyWord Plus(R): TIO<sub>2</sub>; DEGRADATION; PHOTOOXIDATION; OXIDATION; NANOPARTICLES; ZEOLITE; SURFACE; PHENOL; IR

7/8/467 (Item 138 from file: 34)

SciSearch(R) Cited Ref Sci

(c) 2010 The Thomson Corp. All rights reserved.

18981778 **Genuine Article#:** 420WA **Number of References:** 26

**Title:** Photooxidation Products of Ethanol During Photoelectrochemical Operation Using a Nanocrystalline Titania Anode and a Two Compartment Chemically Biased Cell ( ABSTRACT AVAILABLE )

**Publication date:** 20090500

**Journal Subject Category:** CHEMISTRY, PHYSICAL

**Descriptors:** SCIAuthor Keywords: Titanium dioxide ; Ethanol photooxidation ; Photoelectrochemical cell ; Photooxidation intermediates ; Hydrogen production

**Identifiers:** KeyWord Plus(R): HYDROGEN-PRODUCTION; PHOTOCATALYTIC DECOMPOSITION; AZO-DYES; TIO<sub>2</sub>; WATER; DEGRADATION; ENHANCEMENT; SUSPENSIONS; GENERATION; PT-TIO<sub>2</sub>

7/8/468 (Item 139 from file: 34)

SciSearch(R) Cited Ref Sci

(c) 2010 The Thomson Corp. All rights reserved.

18959265 **Genuine Article#:** 416KI **Number of References:** 30

**Title:** Preparation of Immobilized Nanostructured Titania by Using Mesoporous Carbons as Nanoreactors: Investigation of Process Parameters ( ABSTRACT AVAILABLE )

**Publication date:** 20080000

**Journal Subject Category:** ENGINEERING, CHEMICAL

**Descriptors:** SCIAuthor Keywords: Nanoreactor ; Flash Pyrolysis ; Metal Alkoxide ; Titania Nanoparticles ; Mesoporous Materials

**Identifiers:** KeyWord Plus(R): PORE-SIZE DISTRIBUTION; INDOOR AIR LEVEL; ACTIVATED CARBON; METAL-CLUSTERS; TIO<sub>2</sub>; CATALYSIS; DIOXIDE; ANATASE; PHOTODEGRADATION; POLLUTANTS

## Appendix A-5. Irrelevant Titles

7/8/470 (Item 141 from file: 34)

SciSearch(R) Cited Ref Sci

(c) 2010 The Thomson Corp. All rights reserved.

18928130 **Genuine Article#:** 414KU **Number of References:** 20

**Title:** Synthesis and Characterization of Nanostructured Titania Films for Dye-Sensitized Solar Cells ( ABSTRACT AVAILABLE )

**Publication date:** 20090120

**Journal Subject Category:** CHEMISTRY, MULTIDISCIPLINARY

**Descriptors:** SCIAuthor Keywords: Nanostructured titania films ; N719 dye ; Dye-sensitized solar cell ; Adsorption

**Identifiers:** KeyWord Plus(R): TIO2 FILMS; REGULARIZATION; PERFORMANCE; ADSORPTION; COMPLEXES; SURFACE

7/8/471 (Item 142 from file: 34)

SciSearch(R) Cited Ref Sci

(c) 2010 The Thomson Corp. All rights reserved.

18906982 **Genuine Article#:** 412ZE **Number of References:** 66

**Title:** Titanium Dioxide Nanoparticles Aggravate Atopic Dermatitis-Like Skin Lesions in NC/Nga Mice ( ABSTRACT AVAILABLE )

**Publication date:** 20090300

**Journal Subject Category:** MEDICINE, RESEARCH & EXPERIMENTAL

**Descriptors:** SCIAuthor Keywords: atopic dermatitis ; titanium dioxide ; eosinophils ; mast cells ; histamine ; IL-4

**Identifiers:** KeyWord Plus(R): DIESEL EXHAUST PARTICLES; CAUSE ICHTHYOSIS VULGARIS; OF-FUNCTION MUTATIONS; AIRWAY INFLAMMATION; ALLERGIC INFLAMMATION; TOPICAL APPLICATION; INTERFERON-GAMMA; DI-(2-ETHYLHEXYL) PHTHALATE; SUBCHRONIC INHALATION; PULMONARY RESPONSES

7/8/472 (Item 143 from file: 34)

SciSearch(R) Cited Ref Sci

(c) 2010 The Thomson Corp. All rights reserved.

18906073 **Genuine Article#:** 412XX **Number of References:** 38

**Title:** Influence of Ionic Strength, pH, and Cation Valence on Aggregation Kinetics of Titanium Dioxide Nanoparticles ( ABSTRACT AVAILABLE )

**Publication date:** 20090301

**Journal Subject Category:** ENGINEERING, ENVIRONMENTAL; ENVIRONMENTAL SCIENCES

**Identifiers:** KeyWord Plus(R): ZEROVALENT IRON DISPERSIONS; COLLOIDAL STABILITY; AQUEOUS-SOLUTIONS; POROUS-MEDIA; HUMIC-ACID; SURFACE; ADSORPTION; NANOMATERIALS; ANATASE; SEDIMENTATION

## Appendix A-5. Irrelevant Titles

7/8/473 (Item 144 from file: 34)

SciSearch(R) Cited Ref Sci

(c) 2010 The Thomson Corp. All rights reserved.

18906061 **Genuine Article#:** 412XX **Number of References:** 34

**Title:** Aggregation of Titanium Dioxide Nanoparticles: Role of a Fulvic Acid ( ABSTRACT AVAILABLE )

**Publication date:** 20090301

**Journal Subject Category:** ENGINEERING, ENVIRONMENTAL; ENVIRONMENTAL SCIENCES

**Identifiers:** KeyWord Plus(R): FLUORESCENCE CORRELATION SPECTROSCOPY; ADSORBED HUMIC SUBSTANCES; ATOMIC-FORCE MICROSCOPY; NATURAL ORGANIC-MATTER; DIFFUSION-COEFFICIENTS; COLLOID STABILITY; IONIC-STRENGTH; PH; ADSORPTION; SIZE

7/8/474 (Item 145 from file: 34)

SciSearch(R) Cited Ref Sci

(c) 2010 The Thomson Corp. All rights reserved.

18890046 **Genuine Article#:** 409GI **Number of References:** 53

**Title:** Simple and fast annealing synthesis of titanium dioxide nanostructures and morphology transformation during annealing processes ( ABSTRACT AVAILABLE )

**Publication date:** 20090311

**Journal Subject Category:** ENGINEERING, MULTIDISCIPLINARY; NANOSCIENCE & NANOTECHNOLOGY; MATERIALS SCIENCE, MULTIDISCIPLINARY; PHYSICS, APPLIED

**Identifiers:** KeyWord Plus(R): TIO2 NANOWIRE ARRAYS; CONTROLLED GROWTH; ANODIC ALUMINA; SEMICONDUCTING OXIDES; ALPHA-FE2O3 NANOWIRES; GAS SENSORS; NANOBELTS; FABRICATION; TEMPERATURE; MECHANISM

7/8/475 (Item 146 from file: 34)

SciSearch(R) Cited Ref Sci

(c) 2010 The Thomson Corp. All rights reserved.

18890043 **Genuine Article#:** 409GI **Number of References:** 27

**Title:** The photoinduced formation of gold nanoparticles in a mesoporous titania gel monolith ( ABSTRACT AVAILABLE )

**Publication date:** 20090311

**Journal Subject Category:** ENGINEERING, MULTIDISCIPLINARY; NANOSCIENCE & NANOTECHNOLOGY; MATERIALS SCIENCE, MULTIDISCIPLINARY; PHYSICS, APPLIED

**Identifiers:** KeyWord Plus(R): THIN-FILMS; OPTICAL-ABSORPTION; AU NANOPARTICLES; REFRACTIVE-INDEX; TIO2; PARTICLES; SILICA; MICROSTRUCTURE; NANOCLUSTERS; DISSOLUTION

7/8/477 (Item 148 from file: 34)

## Appendix A-5. Irrelevant Titles

SciSearch(R) Cited Ref Sci

(c) 2010 The Thomson Corp. All rights reserved.

18890021 **Genuine Article#:** 411CN **Number of References:** 26

**Title:** BIOLOGICAL EFFECT OF INTRANASALLY INSTILLED TITANIUM DIOXIDE NANOPARTICLES ON FEMALE MICE ( ABSTRACT AVAILABLE )

**Publication date:** 20080800

**Journal Subject Category:** NANOSCIENCE & NANOTECHNOLOGY; MATERIALS SCIENCE, MULTIDISCIPLINARY; PHYSICS, APPLIED

**Descriptors:** SCIAuthor Keywords: Nanoparticles ; TiO<sub>2</sub> ; nanotoxicology ; biological effect ; deposition ; ICP-MS

**Identifiers:** KeyWord Plus(R): ULTRAFINE PARTICLES; IN-VIVO; SUBCHRONIC INHALATION; PULMONARY RESPONSES; CARBON-BLACK; RATS; TIO<sub>2</sub>; SIZE; TRANSLOCATION; TOXICITY

7/8/478 (Item 149 from file: 34)

SciSearch(R) Cited Ref Sci

(c) 2010 The Thomson Corp. All rights reserved.

18870370 **Genuine Article#:** 408RX **Number of References:** 16

**Title:** Photocatalytic printing of inorganic nanopatterns via poly(styrene-block-carbosilane) copolymer thin films on titania substrates ( ABSTRACT AVAILABLE )

**Publication date:** 20090000

**Journal Subject Category:** CHEMISTRY, MULTIDISCIPLINARY

**Identifiers:** KeyWord Plus(R): MOLECULAR-WEIGHT DISTRIBUTION; DIBLOCK COPOLYMER; HYPERBRANCHED POLYMERS; NANOSTRUCTURES; BLOCK; POLYSTYRENE; ARRAYS

7/8/479 (Item 150 from file: 34)

SciSearch(R) Cited Ref Sci

(c) 2010 The Thomson Corp. All rights reserved.

18855494 **Genuine Article#:** 405HC **Number of References:** 48

**Title:** The photostability of wool doped with photocatalytic titanium dioxide nanoparticles ( ABSTRACT AVAILABLE )

**Publication date:** 20090200

**Journal Subject Category:** POLYMER SCIENCE

**Descriptors:** SCIAuthor Keywords: Wool ; Photocatalysis ; Photoyellowing ; Titanium dioxide ; Nanoparticles ; Chemiluminescence

**Identifiers:** KeyWord Plus(R): RUTILE TIO<sub>2</sub> NANOPARTICLES; UV-ABSORBERS; PHOTOINDUCED CHEMILUMINESCENCE; ANATASE; LIGHT; PHOTOLUMINESCENCE; POLYPROPYLENE; POLYETHYLENE; OXIDATION; MIXTURES

7/8/480 (Item 151 from file: 34)

SciSearch(R) Cited Ref Sci

## Appendix A-5. Irrelevant Titles

(c) 2010 The Thomson Corp. All rights reserved.

18851148 **Genuine Article#:** 405UL **Number of References:** 44

**Title:** Influence of hydroxyl contents on photocatalytic activities of polymorphic titania nanoparticles ( ABSTRACT AVAILABLE )

**Publication date:** 20090315

**Journal Subject Category:** MATERIALS SCIENCE, MULTIDISCIPLINARY

**Descriptors:** SCIAuthor Keywords: Polymorphic titania ; Lattice hydroxyls ; Photocatalytic activity

**Identifiers:** KeyWord Plus(R): HYDROTHERMAL BARIUM-TITANATE; ELECTRON-PARAMAGNETIC-RES; CONDITION SOL PROCESS; SOLVOTHERMAL SYNTHESIS; H-1-NMR SPECTROSCOPY; PHASE-TRANSFORMATION; TIO2 NANOPARTICLES; FIBROUS TITANIA; SURFACE; RUTILE

7/8/481 (Item 152 from file: 34)

SciSearch(R) Cited Ref Sci

(c) 2010 The Thomson Corp. All rights reserved.

18847626 **Genuine Article#:** 404QA **Number of References:** 26

**Title:** Catalyst-free low temperature synthesis of discrete anatase titanium dioxide nanocrystals with highly thermal stability and UVC-cut capability ( ABSTRACT AVAILABLE )

**Publication date:** 20080000

**Journal Subject Category:** CHEMISTRY, MULTIDISCIPLINARY; NANOSCIENCE & NANOTECHNOLOGY; MATERIALS SCIENCE, MULTIDISCIPLINARY

**Descriptors:** SCIAuthor Keywords: Catalyst-free ; Low temperature ; Anatase titanium dioxide ; Nanocrystals ; Thermal stability ; Colloids ; Nanoparticle synthesis

**Identifiers:** KeyWord Plus(R): SOLAR-CELLS; PHOTOCATALYTIC ACTIVITY; TIO2 NANOCRYSTALS; GROWTH-KINETICS; RUTILE TIO2; THIN-FILMS; MICROSTRUCTURE; TRANSFORMATION; NANOPARTICLES; HYDROLYSIS

7/8/483 (Item 154 from file: 34)

SciSearch(R) Cited Ref Sci

(c) 2010 The Thomson Corp. All rights reserved.

18819432 **Genuine Article#:** 400PD **Number of References:** 42

**Title:** Facile synthesis of mesoporous titanium dioxide nanocomposites with controllable phase compositions by microwave-assisted esterification ( ABSTRACT AVAILABLE )

**Publication date:** 20090101

**Journal Subject Category:** CHEMISTRY, APPLIED; CHEMISTRY, PHYSICAL; NANOSCIENCE & NANOTECHNOLOGY; MATERIALS SCIENCE, MULTIDISCIPLINARY

**Descriptors:** SCIAuthor Keywords: Mesoporous ; Titanium dioxide ; Phase composition ; Microwave ; Photocatalytic

**Identifiers:** KeyWord Plus(R): SBA-15 MOLECULAR-SIEVE; PHOTOCATALYTIC ACTIVITY; HYDROTHERMAL SYNTHESIS; NANOCRYSTALLINE ANATASE; RUTILE TITANIA; TIO2; TEMPERATURE; NANOPARTICLES; MECHANISMS;

## Appendix A-5. Irrelevant Titles

### MORPHOLOGY

7/8/484 (Item 155 from file: 34)

SciSearch(R) Cited Ref Sci

(c) 2010 The Thomson Corp. All rights reserved.

18819402 **Genuine Article#:** 400PD **Number of References:** 43

**Title: Synthesis and characterisation of novel titania impregnated kaolinite nano-photocatalyst ( ABSTRACT AVAILABLE )**

**Publication date:** 20090101

**Journal Subject Category:** CHEMISTRY, APPLIED; CHEMISTRY, PHYSICAL; NANOSCIENCE & NANOTECHNOLOGY; MATERIALS SCIENCE, MULTIDISCIPLINARY

**Descriptors:** SCIAuthor Keywords: TiO<sub>2</sub> ; Kaolinite ; Photocatalysts ; Heterocoagulation ; Congo red ; Sol-gel

**Identifiers:** KeyWord Plus(R): TIO2 THIN-FILMS; SOL-GEL METHODS; HEAT-TREATMENT; ACID TREATMENT; ORANGE-II; DEGRADATION; NANOPARTICLES; WATER; REMOVAL; OXIDE

7/8/485 (Item 156 from file: 34)

SciSearch(R) Cited Ref Sci

(c) 2010 The Thomson Corp. All rights reserved.

18818573 **Genuine Article#:** 400RL **Number of References:** 24

**Title: Formation and stability of anatase phase of phosphate incorporated and carbon doped titania nanotubes ( ABSTRACT AVAILABLE )**

**Publication date:** 20090204

**Journal Subject Category:** MATERIALS SCIENCE, MULTIDISCIPLINARY

**Descriptors:** SCIAuthor Keywords: Nanostructures ; Differential scanning calorimetry ; X-ray diffraction ; Crystal structure

**Identifiers:** KeyWord Plus(R): PHOTOELECTROCHEMICAL PROPERTIES; HYDROGEN GENERATION; OXIDE; CRYSTALLIZATION; TIO<sub>2</sub>; WATER

7/8/486 (Item 157 from file: 34)

SciSearch(R) Cited Ref Sci

(c) 2010 The Thomson Corp. All rights reserved.

18808549 **Genuine Article#:** 401HK **Number of References:** 30

**Title: Enhanced light-conversion efficiency of titanium-dioxide dye-sensitized solar cells with the addition of indium-tin-oxide and fluorine-tin-oxide nanoparticles in electrode films ( ABSTRACT AVAILABLE )**

**Publication date:** 20080000

**Journal Subject Category:** NANOSCIENCE & NANOTECHNOLOGY; OPTICS

**Descriptors:** SCIAuthor Keywords: dye-sensitized solar cell ; nanoparticle ; electrode film ; light-conversion efficiency

**Identifiers:** KeyWord Plus(R): NANOPOROUS SNO<sub>2</sub> ELECTRODES; SHELL WORKING ELECTRODES; TEMPLATE-BASED GROWTH; CHARGE

## Appendix A-5. Irrelevant Titles

RECOMBINATION; ZNO NANOCRYSTALLITES; OPTICAL-PROPERTIES;  
NANOROD ARRAYS; LAYERS; PHOTOCURRENT; PERFORMANCE

7/8/487 (Item 158 from file: 34)

SciSearch(R) Cited Ref Sci

(c) 2010 The Thomson Corp. All rights reserved.

18800960 **Genuine Article#:** 404LP **Number of References:** 30

**Title: Modeling of Growth and Dissolution of Nanotubular Titania in Fluoride-Containing Electrolytes ( ABSTRACT AVAILABLE )**

**Publication date:** 20090000

**Journal Subject Category:** ELECTROCHEMISTRY; MATERIALS SCIENCE, MULTIDISCIPLINARY

**Identifiers:** KeyWord Plus(R): POROUS ANODIC ALUMINA; TIO<sub>2</sub> NANOTUBES; OXIDE-FILMS; FABRICATION; ANODIZATION; MECHANISM; TRACER; ARRAYS; ACID

7/8/488 (Item 159 from file: 34)

SciSearch(R) Cited Ref Sci

(c) 2010 The Thomson Corp. All rights reserved.

18796500 **Genuine Article#:** 400QZ **Number of References:** 24

**Title: Photocatalytic degradation of furfural by titania nanoparticles in a floating-bed photoreactor ( ABSTRACT AVAILABLE )**

**Publication date:** 20090115

**Journal Subject Category:** ENGINEERING, CHEMICAL

**Descriptors:** SCIAuthor Keywords: Photocatalytic degradation ; Furfural ; Titanium dioxide (TiO<sub>2</sub>) ; Perlite

**Identifiers:** KeyWord Plus(R): TIO<sub>2</sub> PARTICLES; SOLAR LIGHT; WATER; PHOTODEGRADATION; PURIFICATION; PERFORMANCE; OXIDATION; CATALYSTS; PRODUCTS; TOLUENE

7/8/489 (Item 160 from file: 34)

SciSearch(R) Cited Ref Sci

(c) 2010 The Thomson Corp. All rights reserved.

18796471 **Genuine Article#:** 400SF **Number of References:** 37

**Title: Numerical finite volume modeling of dye decolorization using immobilized titania nanophotocatalysis ( ABSTRACT AVAILABLE )**

**Publication date:** 20090201

**Journal Subject Category:** ENGINEERING, CHEMICAL

**Descriptors:** SCIAuthor Keywords: Numerical finite volume ; Nanophotocatalysis ; Modeling ; Decolorization ; Textile dyes ; Immobilized titania nanoparticle

**Identifiers:** KeyWord Plus(R): PHOTOCATALYTIC DEGRADATION; AZO-DYE; AQUEOUS-SOLUTION; METHYLENE-BLUE; TEXTILE DYES; WASTE-WATER;

## Appendix A-5. Irrelevant Titles

TIO<sub>2</sub>; NANOPARTICLES; MINERALIZATION; KINETICS

7/8/490 (Item 161 from file: 34)

SciSearch(R) Cited Ref Sci

(c) 2010 The Thomson Corp. All rights reserved.

18795926 **Genuine Article#:** 403GI **Number of References:** 21

**Title: Enhanced Solar-Radiation Induced Photocatalytic Activity of Surface-Modified Nanocrystalline Anatase-Titania ( ABSTRACT AVAILABLE )**

**Publication date:** 20090300

**Journal Subject Category:** CHEMISTRY, PHYSICAL

**Descriptors:** SCIAuthor Keywords: Nanocrystalline ; Photocatalysis ; Silver ; Sol-gel ; Titania ; UV-reduction

**Identifiers:** KeyWord Plus(R): METHYL-ORANGE; THIN-FILMS; TIO<sub>2</sub>; DIOXIDE; NANOPARTICLES; DEGRADATION; PARTICLES

7/8/491 (Item 162 from file: 34)

SciSearch(R) Cited Ref Sci

(c) 2010 The Thomson Corp. All rights reserved.

18765137 **Genuine Article#:** 399AQ **Number of References:** 45

**Title: Sintering of titania nanoceramic: Densification and grain growth ( ABSTRACT AVAILABLE )**

**Publication date:** 20090300

**Journal Subject Category:** MATERIALS SCIENCE, CERAMICS

**Descriptors:** SCIAuthor Keywords: Sintering ; Grain boundaries ; TiO<sub>2</sub> ; Triple junctions ; Grain growth

**Identifiers:** KeyWord Plus(R): BULK NANOCRYSTALLINE TIO<sub>2</sub>; LOW-TEMPERATURE; PHASE-TRANSFORMATION; ANATASE CERAMICS; TRIPLE JUNCTIONS; OXIDE; SIZE; MICROSTRUCTURE; NANOCOMPOSITES; BEHAVIOR

7/8/493 (Item 164 from file: 34)

SciSearch(R) Cited Ref Sci

(c) 2010 The Thomson Corp. All rights reserved.

18739418 **Genuine Article#:** 396QG **Number of References:** 30

**Title: Substrate-induced coagulation (SIC) of nano-disperse titania in non-aqueous media: The dispersibility and stability of titania in N-methyl-2-pyrrolidinone ( ABSTRACT AVAILABLE )**

**Publication date:** 20090205

**Journal Subject Category:** CHEMISTRY, PHYSICAL

**Descriptors:** SCIAuthor Keywords: Contact angle ; Non-aqueous dispersions ; Electrophoretic mobilities ; Substrate-induced coagulation (SIC) ; Titandioxide ; Zeta potential

**Identifiers:** KeyWord Plus(R): CARBON-BLACK; ADSORPTION; SURFACES; FIBERS; POLAR

## Appendix A-5. Irrelevant Titles

7/8/495 (Item 166 from file: 34)

SciSearch(R) Cited Ref Sci

(c) 2010 The Thomson Corp. All rights reserved.

18724064 **Genuine Article#:** 392UP **Number of References:** 49

**Title: Preparation and application of nanoglued binary titania-silica aerogel (**  
ABSTRACT AVAILABLE )

**Publication date:** 20090115

**Journal Subject Category:** ENGINEERING, ENVIRONMENTAL; ENGINEERING,  
CIVIL; ENVIRONMENTAL SCIENCES

**Descriptors:** SCIAuthor Keywords: Binary aerogel ; Silica matrix ; Photocatalysis ; Reaction  
kinetics ; Hydroxyl radical

**Identifiers:** KeyWord Plus(R): PHOTOCATALYTIC DEGRADATION; SUPPORTED  
TIO<sub>2</sub>; TEREPHTHALATE DOSIMETER; COMPOSITE AEROGELS; HYDROXYL  
RADICALS; AQUEOUS-SOLUTIONS; OXIDATION; KINETICS; DIOXIDE; SURFACE

7/8/496 (Item 167 from file: 34)

SciSearch(R) Cited Ref Sci

(c) 2010 The Thomson Corp. All rights reserved.

18724031 **Genuine Article#:** 392GY **Number of References:** 23

**Title: Structure and photoactivity of titania derived from nanotubes and nanofibers (**  
ABSTRACT AVAILABLE )

**Publication date:** 20090130

**Journal Subject Category:** ENGINEERING, ENVIRONMENTAL; ENGINEERING,  
CIVIL; ENVIRONMENTAL SCIENCES

**Descriptors:** SCIAuthor Keywords: Titania nanotube ; Photoactivity ; Annealing ;  
Crystallinity ; Adsorptivity

**Identifiers:** KeyWord Plus(R): PHOTOCATALYTIC ACTIVITY; ANATASE POWDERS;  
OXIDE NANOTUBES; MICROSTRUCTURES; OXIDATION; LAYER

7/8/497 (Item 168 from file: 34)

SciSearch(R) Cited Ref Sci

(c) 2010 The Thomson Corp. All rights reserved.

18720142 **Genuine Article#:** 394TV **Number of References:** 36

**Title: Development of a Short-Term Inhalation Test in the Rat Using Nano- Titanium  
Dioxide as a Model Substance (** ABSTRACT AVAILABLE )

**Publication date:** 20090000

**Journal Subject Category:** TOXICOLOGY

**Identifiers:** KeyWord Plus(R): CARDIAC TROPONIN-I; GAMMA-GLUTAMYL-  
TRANSPEPTIDASE; PULMONARY TOXICITY; SUBCHRONIC INHALATION;  
RESEARCH STRATEGIES; AMORPHOUS SILICAS; SAFETY EVALUATION;  
WISTAR RATS; RESPONSES; NANOMATERIALS

7/8/499 (Item 170 from file: 34)

## Appendix A-5. Irrelevant Titles

SciSearch(R) Cited Ref Sci

(c) 2010 The Thomson Corp. All rights reserved.

18698286 **Genuine Article#:** 389UE **Number of References:** 40

**Title: Characterisation and spectral properties of surface adsorbed phenosafranine dye in zeolite-Y and ZSM-5: Photosensitisation of embedded nanoparticles of titanium dioxide ( ABSTRACT AVAILABLE )**

**Publication date:** 20090115

**Journal Subject Category:** CHEMISTRY, APPLIED; CHEMISTRY, PHYSICAL; NANOSCIENCE & NANOTECHNOLOGY; MATERIALS SCIENCE, MULTIDISCIPLINARY

**Descriptors:** SCIAuthor Keywords: Phenosafranine ; Titanium dioxide in zeolites ; Zeolite-Y ; ZSM-5 ; Photosensitisation

**Identifiers:** KeyWord Plus(R): CHARGE-TRANSFER; ELECTRON-TRANSFER; INTRAZEOLITE PHOTOCHEMISTRY; PHOTOPHYSICAL PROPERTIES; ORGANIC-MOLECULES; QUANTUM DOTS; TIO<sub>2</sub>; RU(BPY)(3)(2+); SYSTEMS; 2,4,6-TRIPHENYLPYRYLIUM

7/8/500 (Item 171 from file: 34)

SciSearch(R) Cited Ref Sci

(c) 2010 The Thomson Corp. All rights reserved.

18694456 **Genuine Article#:** 389WM **Number of References:** 47

**Title: Nanosized metal deposits on titanium dioxide for augmenting gas-phase toluene photooxidation ( ABSTRACT AVAILABLE )**

**Publication date:** 20090100

**Journal Subject Category:** CHEMISTRY, MULTIDISCIPLINARY; NANOSCIENCE & NANOTECHNOLOGY; MATERIALS SCIENCE, MULTIDISCIPLINARY

**Descriptors:** SCIAuthor Keywords: Photocatalytic ; Titanium dioxide ; Toluene ; Noble metal ; Platinum ; Nanotechnology ; Occupational health ; EHS

**Identifiers:** KeyWord Plus(R): VOLATILE ORGANIC-COMPOUNDS; HETEROGENEOUS PHOTOCATALYTIC OXIDATION; TIO<sub>2</sub> CATALYSTS; VISIBLE-LIGHT; CO OXIDATION; OXALIC-ACID; DEGRADATION; MINERALIZATION; DEACTIVATION; PLATINUM

7/8/501 (Item 172 from file: 34)

SciSearch(R) Cited Ref Sci

(c) 2010 The Thomson Corp. All rights reserved.

18689508 **Genuine Article#:** 389MJ **Number of References:** 30

**Title: Gaseous phase benzene decomposition by non-thermal plasma coupled with nano titania catalyst ( ABSTRACT AVAILABLE )**

**Publication date:** 20090100

**Journal Subject Category:** ENVIRONMENTAL SCIENCES

**Descriptors:** SCIAuthor Keywords: Dielectric barrier discharge ; removal efficiency ; anatase ; carbon dioxide

**Identifiers:** KeyWord Plus(R): DIELECTRIC BARRIER DISCHARGE; VOLATILE ORGANIC-COMPOUNDS; ATMOSPHERIC-PRESSURE; REMOVAL; REACTOR;

## Appendix A-5. Irrelevant Titles

CORONA; VOCS; DESTRUCTION; PERFORMANCE; MECHANISM

7/8/502 (Item 173 from file: 34)

SciSearch(R) Cited Ref Sci

(c) 2010 The Thomson Corp. All rights reserved.

18688818 **Genuine Article#:** 390IA **Number of References:** 19

**Title:** Separation and preconcentration of trace indium(III) from environmental samples with nanometer-size titanium dioxide ( ABSTRACT AVAILABLE )

**Publication date:** 20090100

**Journal Subject Category:** METALLURGY & METALLURGICAL ENGINEERING

**Descriptors:** SCIAuthor Keywords: Nanometer TiO<sub>2</sub> ; Indium ; Preconcentration ; Yellow red soil ; Ultrasonic

**Identifiers:** KeyWord Plus(R): ATOMIC EMISSION-SPECTROMETRY; SOLVENT-EXTRACTION; HYDROCHLORIC-ACID; CHLORIDE MEDIA; ADSORPTION; RECOVERY; COLUMN; WATER; OXIDE

7/8/504 (Item 175 from file: 34)

SciSearch(R) Cited Ref Sci

(c) 2010 The Thomson Corp. All rights reserved.

18665897 **Genuine Article#:** 385UR **Number of References:** 30

**Title:** Surface properties and photocatalytic activity of nanocrystalline titania films ( ABSTRACT AVAILABLE )

**Publication date:** 20081215

**Journal Subject Category:** CHEMISTRY, PHYSICAL

**Descriptors:** SCIAuthor Keywords: TiO<sub>2</sub> films ; Photocatalysis ; XPS ; Hydroxyl radicals ; AFM

**Identifiers:** KeyWord Plus(R): TIO<sub>2</sub> THIN-FILMS; SOL-GEL METHOD; SEMICONDUCTOR PHOTOCATALYSIS; CALCINATION TEMPERATURE; DIOXIDE; POWDERS; LIQUID

7/8/505 (Item 176 from file: 34)

SciSearch(R) Cited Ref Sci

(c) 2010 The Thomson Corp. All rights reserved.

18590766 **Genuine Article#:** 378YU **Number of References:** 61

**Title:** Influence of morphology and surface characteristics on the photocatalytic activity of rutile titania nanocrystals ( ABSTRACT AVAILABLE )

**Publication date:** 20081201

**Journal Subject Category:** MATERIALS SCIENCE, MULTIDISCIPLINARY

**Descriptors:** SCIAuthor Keywords: Nanostructures ; Oxides ; electron microscopy ; Raman spectroscopy ; X-ray diffraction

**Identifiers:** KeyWord Plus(R): TIO<sub>2</sub> PARTICLES; HYDROTHERMAL METHOD; METHYLENE-BLUE; NANOPHASE TIO<sub>2</sub>; RAMAN-SPECTRUM; NANOSIZED TIO<sub>2</sub>;

## Appendix A-5. Irrelevant Titles

AZO-DYE; WATER; DEGRADATION; POWDERS

7/8/506 (Item 177 from file: 34)

SciSearch(R) Cited Ref Sci

(c) 2010 The Thomson Corp. All rights reserved.

18566943 **Genuine Article#:** 377PB **Number of References:** 36

**Title:** Direct electrochemistry of hemoglobin on carbonized titania nanotubes and its application in a sensitive reagentless hydrogen peroxide biosensor ( ABSTRACT AVAILABLE )

**Publication date:** 20081201

**Journal Subject Category:** BIOPHYSICS; BIOTECHNOLOGY & APPLIED MICROBIOLOGY; CHEMISTRY, ANALYTICAL ; ELECTROCHEMISTRY; NANOSCIENCE & NANOTECHNOLOGY

**Descriptors:** SCIAuthor Keywords: Hemoglobin direct electrochemistry ; Carbonized TiO<sub>2</sub> nanotubes ; H<sub>2</sub>O<sub>2</sub> biosensor of third generation

**Identifiers:** KeyWord Plus(R): DIRECT ELECTRON-TRANSFER; MICROBIAL FUEL-CELLS; FILMS; NANOPARTICLES; MYOGLOBIN; IMMOBILIZATION; NANOCOMPOSITE; REACTIVITY

7/8/507 (Item 178 from file: 34)

SciSearch(R) Cited Ref Sci

(c) 2010 The Thomson Corp. All rights reserved.

18552586 **Genuine Article#:** 375SM **Number of References:** 23

**Title:** Impact of mesoporous pore distribution on adsorption of methylene blue onto titania nanotubes in aqueous solution ( ABSTRACT AVAILABLE )

**Publication date:** 20081200

**Journal Subject Category:** CHEMISTRY, APPLIED; CHEMISTRY, PHYSICAL; NANOSCIENCE & NANOTECHNOLOGY; MATERIALS SCIENCE, MULTIDISCIPLINARY

**Descriptors:** SCIAuthor Keywords: Titania nanotubes ; Hydrothermal treatment ; Liquid-phase adsorption ; Methylene blue ; Mesoporosity

**Identifiers:** KeyWord Plus(R): ACTIVATED CARBONS; TIO<sub>2</sub> NANOTUBES; SURFACE; SIZE; DYE

7/8/508 (Item 179 from file: 34)

SciSearch(R) Cited Ref Sci

(c) 2010 The Thomson Corp. All rights reserved.

18552513 **Genuine Article#:** 375SM **Number of References:** 49

**Title:** Transformation of layered titanate nanosheets into nanostructured porous titanium dioxide in polycation solution ( ABSTRACT AVAILABLE )

**Publication date:** 20081200

**Journal Subject Category:** CHEMISTRY, APPLIED; CHEMISTRY, PHYSICAL; NANOSCIENCE & NANOTECHNOLOGY; MATERIALS SCIENCE,

## Appendix A-5. Irrelevant Titles

### MULTIDISCIPLINARY

**Descriptors:** SCIAuthor Keywords: Layered titanate sheet ; Polycation intercalation ; Porous TiO<sub>2</sub> ; Nanorod-like crystal ; Dye adsorption

**Identifiers:** KeyWord Plus(R): MANGANESE OXIDE; MESOPOROUS TIO<sub>2</sub>; PHOTOCATALYTIC ACTIVITY; THIN-FILMS; NANOTUBES; TEMPERATURE; HYDROGEN; ELECTRODE; WATER; PHOTODEGRADATION

7/8/509 (Item 180 from file: 34)

SciSearch(R) Cited Ref Sci

(c) 2010 The Thomson Corp. All rights reserved.

18547084 **Genuine Article#:** 376UB **Number of References:** 18

**Title:** WO<sub>x</sub> nanoclusters highly dispersed on titania nanofibers ( ABSTRACT AVAILABLE )

**Publication date:** 20081000

**Journal Subject Category:** MATERIALS SCIENCE, CERAMICS

**Descriptors:** SCIAuthor Keywords: Tungsten oxide ; TiO<sub>2</sub> ; Catalyst ; Nanofibers ; HRTEM ; HAADF-sTEM ; Raman spectroscopy

**Identifiers:** KeyWord Plus(R): WO<sub>3</sub>-ZRO<sub>2</sub> CATALYSTS; GOLD NANOPARTICLES; TUNGSTEN-OXIDE; CO OXIDATION; NANOTUBES; RAMAN; GENERATION; ZIRCONIA; ACIDITY; ORIGIN

7/8/510 (Item 181 from file: 34)

SciSearch(R) Cited Ref Sci

(c) 2010 The Thomson Corp. All rights reserved.

18539111 **Genuine Article#:** 377OA **Number of References:** 19

**Title:** Novel nanocomposite membranes of sodium alginate filled with polyaniline-coated titanium dioxide for dehydration of 1,4-dioxane/water mixtures ( ABSTRACT AVAILABLE )

**Publication date:** 20081215

**Journal Subject Category:** ENGINEERING, CHEMICAL; WATER RESOURCES

**Descriptors:** SCIAuthor Keywords: NaAlg ; Pervaporation ; TiO<sub>2</sub> ; Nanocomposite membrane ; 1,4-Dioxane ; Crosslinking

**Identifiers:** KeyWord Plus(R): PERVAPORATION SEPARATION; BLEND MEMBRANES

7/8/512 (Item 183 from file: 34)

SciSearch(R) Cited Ref Sci

(c) 2010 The Thomson Corp. All rights reserved.

18528304 **Genuine Article#:** 373WI **Number of References:** 27

**Title:** Analysis of protein phosphorylation by monolithic extraction columns based on poly(divinylbenzene) containing embedded titanium dioxide and zirconium dioxide nano-powders ( ABSTRACT AVAILABLE )

**Publication date:** 20081100

**Journal Subject Category:** BIOCHEMICAL RESEARCH METHODS; BIOCHEMISTRY

## Appendix A-5. Irrelevant Titles

& MOLECULAR BIOLOGY

**Descriptors:** SCIAuthor Keywords: Hollow monolithic-tip ; MALDI-TOF MS ; Nanoparticles ; Phosphopeptides ; Phosphoproteomics

**Identifiers:** KeyWord Plus(R): METAL-AFFINITY-CHROMATOGRAPHY; PHOSPHOPEPTIDE ENRICHMENT; PHOSPHOPROTEOME ANALYSIS; SELECTIVE ENRICHMENT; MASS-SPECTROMETRY; PEPTIDES; POROSITY; SILICA

7/8/513 (Item 184 from file: 34)

SciSearch(R) Cited Ref Sci

(c) 2010 The Thomson Corp. All rights reserved.

18523784 **Genuine Article#:** 374DH **Number of References:** 12

**Title:** Synthesis and characterization of MEH-PPV/nanosized titania hybrids prepared via in situ sol-gel reaction ( ABSTRACT AVAILABLE )

**Publication date:** 20081201

**Journal Subject Category:** MATERIALS SCIENCE, MULTIDISCIPLINARY

**Descriptors:** SCIAuthor Keywords: MEH-PPV/titania hybrid ; In situ sol-gel reaction ; Morphology

**Identifiers:** KeyWord Plus(R): POLYMERS

7/8/514 (Item 185 from file: 34)

SciSearch(R) Cited Ref Sci

(c) 2010 The Thomson Corp. All rights reserved.

18521306 **Genuine Article#:** 370QF **Number of References:** 17

**Title:** Polymer Embedded Nanocrystalline Titania Sorbent for Mo-99-Tc-99m

**Generator** ( ABSTRACT AVAILABLE )

**Publication date:** 20080900

**Journal Subject Category:** CHEMISTRY, MULTIDISCIPLINARY; NANOSCIENCE & NANOTECHNOLOGY; MATERIALS SCIENCE, MULTIDISCIPLINARY; PHYSICS, APPLIED; PHYSICS, CONDENSED MATTER

**Descriptors:** SCIAuthor Keywords: Nano-Crystalline ; Polymer ; TiO<sub>2</sub> ; Radiopharmaceuticals

**Identifiers:** KeyWord Plus(R): ZIRCONIUM MOLYBDATE; TC-99M; MO-99; GEL; CYCLOTRON; PERFORMANCE

7/8/516 (Item 187 from file: 34)

SciSearch(R) Cited Ref Sci

(c) 2010 The Thomson Corp. All rights reserved.

18482720 **Genuine Article#:** 370QB **Number of References:** 21

**Title:** The Antibacterial Effects of Biphasic Brookite-Anatase Titanium Dioxide Nanoparticles on Multiple-Drug-Resistant Staphylococcus aureus ( ABSTRACT AVAILABLE )

**Publication date:** 20080900

**Journal Subject Category:** NANOSCIENCE & NANOTECHNOLOGY; MEDICINE, RESEARCH & EXPERIMENTAL

## Appendix A-5. Irrelevant Titles

**Descriptors:** SCIAuthor Keywords: Antibacterial ; Brookite ; Anatase ; Biphasic ; Titanium Dioxide ; Nanoparticles ; Multiple-Drug-Resistant Staphylococcus aureus ; MRSA ; Ultraviolet Light

**Identifiers:** KeyWord Plus(R): TIO2; INFECTIONS; BACTERIA; PHOTOCATALYSIS; DISINFECTION; LIGHT

7/8/517 (Item 188 from file: 34)

SciSearch(R) Cited Ref Sci

(c) 2010 The Thomson Corp. All rights reserved.

18450821 **Genuine Article#:** 339MA **Number of References:** 40

**Title:** Surfactant-Templated Synthesis and Catalytic Properties of Patterned Nanoporous Titania Supports Loaded with Platinum Nanoparticles ( ABSTRACT AVAILABLE )

**Publication date:** 20080826

**Journal Subject Category:** CHEMISTRY, PHYSICAL; MATERIALS SCIENCE, MULTIDISCIPLINARY

**Identifiers:** KeyWord Plus(R): GAS SHIFT REACTION; PHOTOCATALYTIC ACTIVITY; TIO2; PT/TIO2; HYDROGEN; WATER; TEMPERATURE; REDUCTION; MESOPHASE; OXIDATION

7/8/518 (Item 189 from file: 34)

SciSearch(R) Cited Ref Sci

(c) 2010 The Thomson Corp. All rights reserved.

18450811 **Genuine Article#:** 339MA **Number of References:** 39

**Title:** Nanostructured Titania-Polymer Photovoltaic Devices Made Using PFPE-Based Nanomolding Techniques ( ABSTRACT AVAILABLE )

**Publication date:** 20080826

**Journal Subject Category:** CHEMISTRY, PHYSICAL; MATERIALS SCIENCE, MULTIDISCIPLINARY

**Identifiers:** KeyWord Plus(R): SOLAR-CELLS; MESOPOROUS TITANIA; CONJUGATED POLYMERS; SOFT LITHOGRAPHY; THIN-FILMS; TIO2; FABRICATION; PERFORMANCE; MORPHOLOGY; MICROSTRUCTURES

7/8/519 (Item 190 from file: 34)

SciSearch(R) Cited Ref Sci

(c) 2010 The Thomson Corp. All rights reserved.

18442136 **Genuine Article#:** 363WB **Number of References:** 43

**Title:** Inflammatory response of mice to manufactured titanium dioxide nanoparticles: Comparison of size effects through different exposure routes ( ABSTRACT AVAILABLE )

**Publication date:** 20070000

**Journal Subject Category:** NANOSCIENCE & NANOTECHNOLOGY; TOXICOLOGY

## Appendix A-5. Irrelevant Titles

**Descriptors:** SCIAuthor Keywords: Aerosol ; inhalation ; instillation ; murine models ; nanoparticle agglomeration ; aggregation ; titanium dioxide ; inflammation

**Identifiers:** KeyWord Plus(R): PARTICLE SURFACE-AREA; INTRATRACHEAL INSTILLATION; INHALATION TOXICOLOGY; SUBCHRONIC INHALATION; PULMONARY RESPONSES; EPITHELIAL-CELLS; LUNG; ULTRAFINE; TOXICITY; RATS

7/8/520 (Item 191 from file: 34)

SciSearch(R) Cited Ref Sci

(c) 2010 The Thomson Corp. All rights reserved.

18440492 **Genuine Article#:** 363OJ **Number of References:** 31

**Title:** Hydroxyapatite/titania nanocomposites derived by combining high-energy ball milling with spark plasma sintering processes ( ABSTRACT AVAILABLE )

**Publication date:** 20081200

**Journal Subject Category:** MATERIALS SCIENCE, CERAMICS

**Descriptors:** SCIAuthor Keywords: Milling ; Nanocomposites ; X-ray-methods ; Mechanical properties ; Biomedical applications

**Identifiers:** KeyWord Plus(R): IN-VITRO; COMPOSITE COATINGS; REINFORCED HYDROXYAPATITE; TITANIUM; OSTEOBLASTS; CERAMICS; BEHAVIOR; BIOMATERIALS; IMPLANTS; DIOXIDE

7/8/521 (Item 192 from file: 34)

SciSearch(R) Cited Ref Sci

(c) 2010 The Thomson Corp. All rights reserved.

18436809 **Genuine Article#:** 361LO **Number of References:** 25

**Title:** An Approach for Controllable Synthesis of Different-Phase Titanium Dioxide Nanocomposites with Peroxotitanium Complex as Precursor

( ABSTRACT AVAILABLE )

**Publication date:** 20081000

**Journal Subject Category:** CHEMISTRY, PHYSICAL; NANOSCIENCE & NANOTECHNOLOGY; MATERIALS SCIENCE, MULTIDISCIPLINARY

**Identifiers:** KeyWord Plus(R): LOW-TEMPERATURE SYNTHESIS; MODIFIED ANATASE SOL; TIO<sub>2</sub> THIN-FILM; ACID-SOLUTION; AQUEOUS-SOLUTIONS; BROOKITE; RUTILE; TRANSFORMATION; NANOPARTICLES; NANORODS

7/8/522 (Item 193 from file: 34)

SciSearch(R) Cited Ref Sci

(c) 2010 The Thomson Corp. All rights reserved.

18431454 **Genuine Article#:** 363SL **Number of References:** 42

**Title:** Purification of water containing agricultural organophosphorus pollutant using titania nanophotocatalysis: Laboratory studies and numerical modeling ( ABSTRACT AVAILABLE )

**Publication date:** 20080930

## Appendix A-5. Irrelevant Titles

**Journal Subject Category:** ENGINEERING, CHEMICAL; WATER RESOURCES  
**Descriptors:** SCIAuthor Keywords: Fenitrothion ; Degradation ; Nanophotocatalysis ; Numerical modeling ; Immobilized nanoparticle ; Mineralization  
**Identifiers:** KeyWord Plus(R): PHOTOCATALYTIC DEGRADATION; IMMOBILIZED NANOPARTICLES; INSECTICIDE FENITROTHION; OXIDE NANOPARTICLES; ORGANIC POLLUTANTS; HYDROGEN-PEROXIDE; METHYLENE-BLUE; TEXTILE DYES; WASTE-WATER; TIO2

7/8/523 (Item 194 from file: 34)

SciSearch(R) Cited Ref Sci

(c) 2010 The Thomson Corp. All rights reserved.

18414910 **Genuine Article#:** 364UG **Number of References:** 15

**Title:** Surface modification of titanium dioxide nanoparticles by polyaniline via an in situ method ( ABSTRACT AVAILABLE )

**Publication date:** 20081100

**Journal Subject Category:** BIOTECHNOLOGY & APPLIED MICROBIOLOGY; CHEMISTRY, MULTIDISCIPLINARY; ENGINEERING, CHEMICAL

**Descriptors:** SCIAuthor Keywords: TiO2 nanoparticles ; polyaniline ; in situ polymerisation ; dispersion ; photoactivity

**Identifiers:** KeyWord Plus(R): COMPOSITES; FILM

7/8/524 (Item 195 from file: 34)

SciSearch(R) Cited Ref Sci

(c) 2010 The Thomson Corp. All rights reserved.

18399752 **Genuine Article#:** 358SO **Number of References:** 20

**Title:** Properties of titania/hydroxyapatite nanostructured coating produced by gas tunnel type plasma spraying ( ABSTRACT AVAILABLE )

**Publication date:** 20080904

**Journal Subject Category:** MATERIALS SCIENCE, MULTIDISCIPLINARY; PHYSICS, APPLIED

**Descriptors:** SCIAuthor Keywords: Titania/hydroxyapatite composite coating ; Gas tunnel type plasma spraying ; TiO2/HAP ; Phase composition ; Photo-catalysis

**Identifiers:** KeyWord Plus(R): PHOTOCATALYTIC PROPERTIES; CERAMIC COATINGS; TIO2 COATINGS; MICROSTRUCTURE; POWDERS; JET

7/8/525 (Item 196 from file: 34)

SciSearch(R) Cited Ref Sci

(c) 2010 The Thomson Corp. All rights reserved.

18398974 **Genuine Article#:** 356AJ **Number of References:** 40

**Title:** The promotion effect of titania nanoparticles on the direct electrochemistry of lactate dehydrogenase sol-gel modified gold electrode ( ABSTRACT AVAILABLE )

**Publication date:** 20080915

**Journal Subject Category:** CHEMISTRY, ANALYTICAL

**Descriptors:** SCIAuthor Keywords: lactate dehydrogenase (LDH) ; direct electrochemistry ;

## Appendix A-5. Irrelevant Titles

sol-gel ; nano-TiO<sub>2</sub> ; lactic acid

**Identifiers:** KeyWord Plus(R): GLASSY-CARBON ELECTRODE; FILM-MODIFIED ELECTRODE; PLASMON RESONANCE; REDOX ENZYMES; AMINO-ACIDS; ELECTROCATALYSIS; HEMOGLOBIN; NANOTUBES; CATALYSIS; CATALASE

7/8/526 (Item 197 from file: 34)

SciSearch(R) Cited Ref Sci

(c) 2010 The Thomson Corp. All rights reserved.

18389477 **Genuine Article#:** 357GJ **Number of References:** 26

**Title:** Photo-catalysis using titanium dioxide nanotube layers ( ABSTRACT AVAILABLE )

**Publication date:** 20080925

**Journal Subject Category:** CHEMISTRY, PHYSICAL

**Descriptors:** SCIAuthor Keywords: titanium dioxide nanotubes ; anatase ; rutile ; photo-degradation ; acid orange 7 (AO7) ; mineralization

**Identifiers:** KeyWord Plus(R): PHOTOCATALYTIC DEGRADATION; ENVIRONMENTAL APPLICATIONS; CRYSTALLINE ANATASE; TIO<sub>2</sub> PHOTOCATALYSTS; ANODIC-OXIDATION; IMMOBILIZED TIO<sub>2</sub>; WATER-TREATMENT; POROUS ALUMINA; ARRAYS; FILMS

7/8/527 (Item 198 from file: 34)

SciSearch(R) Cited Ref Sci

(c) 2010 The Thomson Corp. All rights reserved.

18379540 **Genuine Article#:** 356GB **Number of References:** 11

**Title:** Improved short-circuit photocurrent densities in dye-sensitized solar cells based on ordered arrays of titania nanotubule electrodes ( ABSTRACT AVAILABLE )

**Publication date:** 20090100

**Journal Subject Category:** MATERIALS SCIENCE, MULTIDISCIPLINARY; PHYSICS, APPLIED

**Descriptors:** SCIAuthor Keywords: nanotubules ; titania ; diffusion ; photoelectrochemical

7/8/528 (Item 199 from file: 34)

SciSearch(R) Cited Ref Sci

(c) 2010 The Thomson Corp. All rights reserved.

18368997 **Genuine Article#:** 355RT **Number of References:** 43

**Title:** Photosensitive high-refractive-index poly(acrylic acid)-graft-poly(ethylene glycol methacrylate) nanocrystalline titania hybrid films ( ABSTRACT AVAILABLE )

**Publication date:** 20080904

**Journal Subject Category:** POLYMER SCIENCE

**Descriptors:** SCIAuthor Keywords: graft copolymers ; hybrid materials ; optical films ; patterning ; titania

**Identifiers:** KeyWord Plus(R): ORGANIC-INORGANIC HYBRID; OPTICAL THIN-FILMS; SOL-GEL PROCESS; POLY(ETHYLENE GLYCOL); TIO<sub>2</sub>; POLYMERS;

## Appendix A-5. Irrelevant Titles

SILICA; PMMA; NANOCOMPOSITES; NANOHYBRIDS

7/8/531 (Item 202 from file: 34)

SciSearch(R) Cited Ref Sci

(c) 2010 The Thomson Corp. All rights reserved.

18348835 **Genuine Article#:** 352WN **Number of References:** 21

**Title:** Microarrayed nanostructured titania thin films functionalized for hydrogen detection ( ABSTRACT AVAILABLE )

**Publication date:** 20080000

**Journal Subject Category:** ELECTROCHEMISTRY; MATERIALS SCIENCE, COATINGS & FILMS

**Identifiers:** KeyWord Plus(R): CARBON-MONOXIDE; TIO<sub>2</sub>; SENSORS; CELLS; TEMPERATURE; CATALYSTS; DIOXIDE; OXIDES

7/8/532 (Item 203 from file: 34)

SciSearch(R) Cited Ref Sci

(c) 2010 The Thomson Corp. All rights reserved.

18338036 **Genuine Article#:** 353IW **Number of References:** 43

**Title:** Surface chemical structure of titania-silica nanocomposite powder ( ABSTRACT AVAILABLE )

**Publication date:** 20081000

**Journal Subject Category:** MULTIDISCIPLINARY SCIENCES

**Descriptors:** SCIAuthor Keywords: surface structure ; titania-silica ; sol-gel ; suboxide ; nanocomposite

**Identifiers:** KeyWord Plus(R): VISIBLE-LIGHT IRRADIATION; SOL-GEL PROCESS; PHOTOCATALYTIC ACTIVITY; ACTIVE-SITES; MIXED OXIDES; THIN-FILMS; TIO<sub>2</sub>; TIO<sub>2</sub>/SIO<sub>2</sub>; MICROSTRUCTURE; TIO<sub>2</sub>-SIO<sub>2</sub>

7/8/533 (Item 204 from file: 34)

SciSearch(R) Cited Ref Sci

(c) 2010 The Thomson Corp. All rights reserved.

18331330 **Genuine Article#:** 351YD **Number of References:** 42

**Title:** Oxidative stress and apoptosis induced by titanium dioxide nanoparticles in cultured BEAS-2B cells ( ABSTRACT AVAILABLE )

**Publication date:** 20080828

**Journal Subject Category:** TOXICOLOGY

**Descriptors:** SCIAuthor Keywords: titanium dioxide nanoparticles ; apoptosis ; oxidative stress ; BEAS-2B cells

**Identifiers:** KeyWord Plus(R): QUANTUM DOTS; EPITHELIAL-CELLS; INDUCED DNA; TOXICITY; PARTICLES; MICE; MITOCHONDRIA; EXPOSURE; CANCER; DAMAGE

## Appendix A-5. Irrelevant Titles

7/8/534 (Item 205 from file: 34)

SciSearch(R) Cited Ref Sci

(c) 2010 The Thomson Corp. All rights reserved.

18327776 **Genuine Article#:** 351KM **Number of References:** 34

**Title:** The study of photocatalysis under ultraviolet plus visible two-beam light irradiation using undoped nano-titanium dioxide ( ABSTRACT AVAILABLE )

**Publication date:** 20081115

**Journal Subject Category:** MATERIALS SCIENCE, MULTIDISCIPLINARY

**Descriptors:** SCIAuthor Keywords: nano-TiO<sub>2</sub> ; photocatalysis ; d-d transition ; two-beam light-induced photocatalysis

**Identifiers:** KeyWord Plus(R): SOL-GEL METHOD; ANATASE TIO<sub>2</sub>; DOPED TIO<sub>2</sub>; FILMS; PHOTOLUMINESCENCE; PARTICLES; DEGRADATION; DEPOSITION; SPECTRA

7/8/535 (Item 206 from file: 34)

SciSearch(R) Cited Ref Sci

(c) 2010 The Thomson Corp. All rights reserved.

18291562 **Genuine Article#:** 349IU **Number of References:** 36

**Title:** Cytotoxicity of titanium dioxide nanoparticles in mouse fibroblast cells ( ABSTRACT AVAILABLE )

**Publication date:** 20080900

**Journal Subject Category:** CHEMISTRY, MEDICINAL; CHEMISTRY, MULTIDISCIPLINARY; TOXICOLOGY

**Identifiers:** KeyWord Plus(R): EPITHELIAL-CELLS; IN-VITRO; PULMONARY TOXICITY; OXIDATIVE DAMAGE; PARTICLES; NANOMATERIALS; APOPTOSIS; RATS

7/8/536 (Item 207 from file: 34)

SciSearch(R) Cited Ref Sci

(c) 2010 The Thomson Corp. All rights reserved.

18257760 **Genuine Article#:** 343PY **Number of References:** 21

**Title:** Credible role of copper oxide on structure of nanocrystalline mesoporous titanium dioxide ( ABSTRACT AVAILABLE )

**Publication date:** 20080900

**Journal Subject Category:** CHEMISTRY, MULTIDISCIPLINARY

**Descriptors:** SCIAuthor Keywords: TiO<sub>2</sub> ; CuO ; mesoporous ; nanocrystalline

**Identifiers:** KeyWord Plus(R): PHOTOCATALYTIC DEGRADATION; OPTICAL-PROPERTIES; MOLECULAR-SIEVES; OXIDATION; PHENOL; TIO<sub>2</sub>; CUO; REDUCTION; CATALYSTS; ANATASE

7/8/537 (Item 208 from file: 34)

## Appendix A-5. Irrelevant Titles

SciSearch(R) Cited Ref Sci

(c) 2010 The Thomson Corp. All rights reserved.

18250018 **Genuine Article#:** 342WL **Number of References:** 19

**Title:** Ambient atmosphere bonding of titanium foil to a transparent conductive oxide and anodic growth of titanium dioxide nanotubes ( ABSTRACT AVAILABLE )

**Publication date:** 20080900

**Journal Subject Category:** ENERGY & FUELS; MATERIALS SCIENCE, MULTIDISCIPLINARY

**Descriptors:** SCIAuthor Keywords: TiO<sub>2</sub> ; anodization ; nanotubes ; adhesion ; transparent conducting oxide

**Identifiers:** KeyWord Plus(R): SENSITIZED SOLAR-CELLS; TIO<sub>2</sub> FILMS; ARRAYS; ZINC; ANODIZATION; TIN; FABRICATION; EFFICIENCY; TRANSPORT

7/8/538 (Item 209 from file: 34)

SciSearch(R) Cited Ref Sci

(c) 2010 The Thomson Corp. All rights reserved.

18214841 **Genuine Article#:** 341PY **Number of References:** 23

**Title:** Effect of rutile titanium dioxide nano-particles and hindered amine light stabilizer on the ageing resistant properties of ABS ( ABSTRACT AVAILABLE )

**Publication date:** 20080800

**Journal Subject Category:** POLYMER SCIENCE

**Descriptors:** SCIAuthor Keywords: nano-scale rutile TiO<sub>2</sub> ; HALS ; ABS ; impact properties ; aging resistance ; fractured surface morphology

**Identifiers:** KeyWord Plus(R): OPTICAL-PROPERTIES; DEGRADATION; POLYMERS

7/8/539 (Item 210 from file: 34)

SciSearch(R) Cited Ref Sci

(c) 2010 The Thomson Corp. All rights reserved.

18207150 **Genuine Article#:** 337JJ **Number of References:** 36

**Title:** Fabrication, characterization and photocatalytic activity of Gd<sup>3+</sup>-doped titania nanoparticles with mesostructure ( ABSTRACT AVAILABLE )

**Publication date:** 20080901

**Journal Subject Category:** CHEMISTRY, APPLIED; CHEMISTRY, PHYSICAL; NANOSCIENCE & NANOTECHNOLOGY; MATERIALS SCIENCE, MULTIDISCIPLINARY

**Descriptors:** SCIAuthor Keywords: Gd-doping ; mesostructure ; nanoparticle ; Titania ; photocatalysis

**Identifiers:** KeyWord Plus(R): TIO<sub>2</sub> FILMS; SEMICONDUCTOR ELECTRODES; ACETONITRILE SOLUTIONS; DIOXIDE NANOPARTICLES; PHASE-TRANSFORMATION; LIGHT; DEGRADATION; BEHAVIOR; OXIDES

7/8/540 (Item 211 from file: 34)

SciSearch(R) Cited Ref Sci

(c) 2010 The Thomson Corp. All rights reserved.

## Appendix A-5. Irrelevant Titles

18205055 **Genuine Article#:** 339FG **Number of References:** 49

**Title:** Nonaqueous synthesis of metal oxide nanoparticles: Short review and doped titanium dioxide as case study for the preparation of transition metal-doped oxide nanoparticles ( ABSTRACT AVAILABLE )

**Publication date:** 20080700

**Journal Subject Category:** CHEMISTRY, INORGANIC & NUCLEAR; CHEMISTRY, PHYSICAL

**Descriptors:** SCIAuthor Keywords: nonaqueous synthesis ; metal oxides ; nanoparticles ; doped titania

**Identifiers:** KeyWord Plus(R): ORIENTED ATTACHMENT; MAGNETIC-PROPERTIES; NANOCRYSTALS; TIO<sub>2</sub>; FERROMAGNETISM; MECHANISM; NANORODS; ROUTES; GROWTH; ZNO

7/8/541 (Item 212 from file: 34)

SciSearch(R) Cited Ref Sci

(c) 2010 The Thomson Corp. All rights reserved.

18201397 **Genuine Article#:** 338GH **Number of References:** 57

**Title:** Bandgap renormalization in titania modified nanostructured tungsten oxide thin films prepared by pulsed laser deposition technique for solar cell applications ( ABSTRACT AVAILABLE )

**Publication date:** 20080801

**Journal Subject Category:** PHYSICS, APPLIED

**Identifiers:** KeyWord Plus(R): WO<sub>3</sub> FILMS; ELECTRICAL-CONDUCTIVITY; RAMAN-SPECTROSCOPY; OPTICAL-PROPERTIES; WO<sub>3</sub>-TIO<sub>2</sub> FILMS; TEMPERATURE; TIO<sub>2</sub>; SIZE; DEPENDENCE; SCATTERING

7/8/542 (Item 213 from file: 34)

SciSearch(R) Cited Ref Sci

(c) 2010 The Thomson Corp. All rights reserved.

18194548 **Genuine Article#:** 339AL **Number of References:** 29

**Title:** Ecotoxicological characterization of photoelectrocatalytic process for degradation of pentachlorophenol on titania nanotubes electrode ( ABSTRACT AVAILABLE )

**Publication date:** 20080900

**Journal Subject Category:** ENVIRONMENTAL SCIENCES; TOXICOLOGY

**Descriptors:** SCIAuthor Keywords: photoelectrocatalysis ; pentachlorophenol ; luminescent bacteria ; EROD induction ; dioxin ; **environmental** safety

**Identifiers:** KeyWord Plus(R): DIBENZO-P-DIOXINS; WASTE-WATER TREATMENT; PHOTOCATALYTIC DEGRADATION; VIBRIO-FISCHERI; FILM ELECTRODES; TOXICITY; TIO<sub>2</sub>; PHOTOLYSIS; PHOTODEGRADATION; EFFLUENTS

7/8/544 (Item 215 from file: 34)

## Appendix A-5. Irrelevant Titles

SciSearch(R) Cited Ref Sci

(c) 2010 The Thomson Corp. All rights reserved.

18155714 **Genuine Article#:** 334ZZ **Number of References:** 24

**Title:** Intermolecular interactions and the structure of near-surface layers in heterogeneous two-component systems based on nanocrystallites of titanium dioxide ( ABSTRACT AVAILABLE )

**Publication date:** 20080500

**Journal Subject Category:** CHEMISTRY, INORGANIC & NUCLEAR; CHEMISTRY, PHYSICAL

**Descriptors:** SCIAuthor Keywords: heterogeneous system ; titanium dioxide ; nanocrystallite ; benzophenone ; 4-pentyl-4'-cyanobiphenyl ; hydrogen bond ; near-surface layer ; structure ; IR spectrum ; molecular simulation

**Identifiers:** KeyWord Plus(R): TIO2

7/8/545 (Item 216 from file: 34)

SciSearch(R) Cited Ref Sci

(c) 2010 The Thomson Corp. All rights reserved.

18132487 **Genuine Article#:** 329AQ **Number of References:** 29

**Title:** Effect of process parameters on the chemical vapour synthesis of nanocrystalline titania ( ABSTRACT AVAILABLE )

**Publication date:** 20080807

**Journal Subject Category:** PHYSICS, APPLIED

**Identifiers:** KeyWord Plus(R): THERMODYNAMIC ANALYSIS; TIO2; NANOPARTICLE; TEMPERATURE; POWDERS; REACTOR; FILMS

7/8/546 (Item 217 from file: 34)

SciSearch(R) Cited Ref Sci

(c) 2010 The Thomson Corp. All rights reserved.

18128314 **Genuine Article#:** 331GA **Number of References:** 34

**Title:** Highly photoactive monodisperse titania hollow nanospheres ( ABSTRACT AVAILABLE )

**Publication date:** 20080731

**Journal Subject Category:** CHEMISTRY, PHYSICAL

**Descriptors:** SCIAuthor Keywords: sol-gel synthesis ; core-shell approach ; TiO2 hollow nanospheres ; photocatalysis

**Identifiers:** KeyWord Plus(R): PHOTOCATALYTIC DEGRADATION; MESOPOROUS TIO2; AZO-DYES; MICROSPHERES; SPHERES; NANOPARTICLES; EXTRACTION; OXIDATION; LIGHT; FILMS

7/8/547 (Item 218 from file: 34)

SciSearch(R) Cited Ref Sci

(c) 2010 The Thomson Corp. All rights reserved.

18127953 **Genuine Article#:** 330FZ **Number of References:** 22

**Title:** Synergistic effect in photocatalysis as observed for mixed-phase nanocrystalline

## Appendix A-5. Irrelevant Titles

**titania processed via sol-gel solvent mixing and calcination** ( ABSTRACT AVAILABLE )

**Publication date:** 20080731

**Journal Subject Category:** CHEMISTRY, PHYSICAL; NANOSCIENCE & NANOTECHNOLOGY; MATERIALS SCIENCE, MULTIDISCIPLINARY

**Identifiers:** KeyWord Plus(R): TIO2 PARTICLES; RUTILE PHASE; ANATASE; OXIDATION; POWDERS; NANOPARTICLES; SIZE

7/8/548 (Item 219 from file: 34)

SciSearch(R) Cited Ref Sci

(c) 2010 The Thomson Corp. All rights reserved.

18127937 **Genuine Article#:** 330FZ **Number of References:** 28

**Title: Highly photoconductive copper phthalocyanine-coated titania nanoarrays via secondary deposition** ( ABSTRACT AVAILABLE )

**Publication date:** 20080731

**Journal Subject Category:** CHEMISTRY, PHYSICAL; NANOSCIENCE & NANOTECHNOLOGY; MATERIALS SCIENCE, MULTIDISCIPLINARY

**Identifiers:** KeyWord Plus(R): NANOWIRE ARRAYS; ELECTROPHORETIC DEPOSITION; FABRICATION; NANORODS; ALUMINA; CELLS

7/8/549 (Item 220 from file: 34)

SciSearch(R) Cited Ref Sci

(c) 2010 The Thomson Corp. All rights reserved.

18120838 **Genuine Article#:** 332LF **Number of References:** 36

**Title: Biomimetic synthesis of titania nanoparticles induced by protamine** ( ABSTRACT AVAILABLE )

**Publication date:** 20080000

**Journal Subject Category:** CHEMISTRY, INORGANIC & NUCLEAR

**Identifiers:** KeyWord Plus(R): SILICA FORMATION; NEUTRAL PH; SILICIFICATION; LYSOZYME; DIOXIDE; BIOMINERALIZATION; MORPHOGENESIS; SPERMIDINE; CHEMISTRY; PHOSPHATE

7/8/550 (Item 221 from file: 34)

SciSearch(R) Cited Ref Sci

(c) 2010 The Thomson Corp. All rights reserved.

18115591 **Genuine Article#:** 332AH **Number of References:** 36

**Title: One-step synthesis of noble metal-titanium dioxide nanocomposites in a flame aerosol reactor** ( ABSTRACT AVAILABLE )

**Publication date:** 20080801

**Journal Subject Category:** CHEMISTRY, PHYSICAL; ENVIRONMENTAL SCIENCES

**Descriptors:** SCIAuthor Keywords: flame synthesis ; platinum ; palladium ; TiO2 nanoparticle ; photocatalysis

## Appendix A-5. Irrelevant Titles

**Identifiers:** KeyWord Plus(R): PHOTOCATALYTIC ACTIVITY; STRUCTURAL-PROPERTIES; CATALYTIC BEHAVIOR; OXIDATION; TIO<sub>2</sub>; NANOPARTICLES; PHOTOOXIDATION; PHOTODEGRADATION; HYDROGENATION; ENHANCEMENT

7/8/551 (Item 222 from file: 34)

SciSearch(R) Cited Ref Sci

(c) 2010 The Thomson Corp. All rights reserved.

18106179 **Genuine Article#:** 328RI **Number of References:** 36

**Title:** Synthesis and characterization of copper ions surface-doped titanium dioxide nanotubes ( ABSTRACT AVAILABLE )

**Publication date:** 20080800

**Journal Subject Category:** MATERIALS SCIENCE, MULTIDISCIPLINARY

**Descriptors:** SCIAuthor Keywords: nanostructures ; oxides ; chemical synthesis ; X-ray diffraction ; catalytic properties

**Identifiers:** KeyWord Plus(R): PHOTOCATALYTIC ACTIVITY; TIO<sub>2</sub> NANOTUBES; OXIDE; NANOPARTICLES; FABRICATION; PARTICLES; NANOWIRES; NANORODS; COMPOSITES; NANOFIBERS

7/8/552 (Item 223 from file: 34)

SciSearch(R) Cited Ref Sci

(c) 2010 The Thomson Corp. All rights reserved.

18102804 **Genuine Article#:** 327TS **Number of References:** 34

**Title:** Photocatalytic inactivation of viruses using titanium dioxide nanoparticles and low-pressure UV light

( ABSTRACT AVAILABLE )

**Publication date:** 20080000

**Journal Subject Category:** ENGINEERING, ENVIRONMENTAL; ENVIRONMENTAL SCIENCES

**Descriptors:** SCIAuthor Keywords: disinfection ; UV ; photocatalysis ; titanium dioxide ; PRD1 ; MS2 ; phi-X174 ; fr

**Identifiers:** KeyWord Plus(R): ESCHERICHIA-COLI; DISINFECTION; TIO<sub>2</sub>; WATER; BACTERIOPHAGE-PRD1; STANDARDIZATION; RADIATION; PEPTIDES; ANATASE; PHASES

7/8/553 (Item 224 from file: 34)

SciSearch(R) Cited Ref Sci

(c) 2010 The Thomson Corp. All rights reserved.

18086948 **Genuine Article#:** 323UV **Number of References:** 11

**Title:** Sol-gel preparation and characterization of high activity titanium dioxide nanocrystalline photocatalyst ( ABSTRACT AVAILABLE )

**Publication date:** 20080500

**Journal Subject Category:** MATERIALS SCIENCE, MULTIDISCIPLINARY; METALLURGY & METALLURGICAL ENGINEERING

## Appendix A-5. Irrelevant Titles

**Descriptors:** SCIAuthor Keywords: sol-gel ; nanocrystalline titanium dioxide ; photocatalytic activity ; methyl orange

**Identifiers:** KeyWord Plus(R): HEAT-TREATMENT; KINETICS

7/8/554 (Item 225 from file: 34)

SciSearch(R) Cited Ref Sci

(c) 2010 The Thomson Corp. All rights reserved.

18081608 **Genuine Article#:** 325FV **Number of References:** 36

**Title:** Process-property-performance relationships for titanium dioxide coatings engineered from nanostructured and conventional powders ( ABSTRACT AVAILABLE )

**Publication date:** 20081000

**Journal Subject Category:** MATERIALS SCIENCE, MULTIDISCIPLINARY

**Descriptors:** SCIAuthor Keywords: thermal spray coating ; nanostructured titania (TiO<sub>2</sub>) powder ; dry-sliding wear ; microstructure ; **processing**

**Identifiers:** KeyWord Plus(R): SLIDING-WEAR BEHAVIOR; ZIRCONIA COATINGS; CERAMIC COATINGS; COMPOSITE COATINGS; PLASMA; HVOF; MICROSTRUCTURE; RESISTANCE; ALUMINA; NANOPOWDERS

7/8/555 (Item 226 from file: 34)

SciSearch(R) Cited Ref Sci

(c) 2010 The Thomson Corp. All rights reserved.

18079242 **Genuine Article#:** 324NC **Number of References:** 26

**Title:** Highly photocatalytic activity of metallic hydroxide/titanium dioxide nanoparticles prepared via a modified wet precipitation process ( ABSTRACT AVAILABLE )

**Publication date:** 20080815

**Journal Subject Category:** CHEMISTRY, PHYSICAL

**Descriptors:** SCIAuthor Keywords: titanium dioxide ; surface modification ; ferric hydroxide ; cupric hydroxide ; photocatalysis

**Identifiers:** KeyWord Plus(R): TIO<sub>2</sub> PHOTOCATALYSTS; BAND-GAP; DEGRADATION; PHENOL; PHASE; WATER; OXIDE; IONS; DYE

7/8/556 (Item 227 from file: 34)

SciSearch(R) Cited Ref Sci

(c) 2010 The Thomson Corp. All rights reserved.

18058066 **Genuine Article#:** 323NG **Number of References:** 21

**Title:** Preparation and characteristics of poly(amide-imide)/titania nanocomposite thin films ( ABSTRACT AVAILABLE )

**Publication date:** 20080630

**Journal Subject Category:** MATERIALS SCIENCE, MULTIDISCIPLINARY; MATERIALS SCIENCE, COATINGS & FILMS; PHYSICS, APPLIED; PHYSICS, CONDENSED MATTER

**Descriptors:** SCIAuthor Keywords: poly(amide imide) ; titania ; sol-gel ; hydrogen bond ;

## Appendix A-5. Irrelevant Titles

nanocomposite

**Identifiers:** KeyWord Plus(R): IN-SITU FORMATION; INTERFACIAL ADHESION; HYBRID FILMS; MECHANICAL-PROPERTIES; POLYIMIDE FILMS; COMPLEXES; TITANIUM

7/8/557 (Item 228 from file: 34)

SciSearch(R) Cited Ref Sci

(c) 2010 The Thomson Corp. All rights reserved.

18046679 **Genuine Article#:** 320LY **Number of References:** 26

**Title:** Fabrication of titania nanocoatings on ZnS-type phosphors using the titanium diethanolamine as the precursor in an aqueous solution ( ABSTRACT AVAILABLE )

**Publication date:** 20080800

**Journal Subject Category:** MATERIALS SCIENCE, CERAMICS

**Descriptors:** SCIAuthor Keywords: sol-gel ; nanocoatings ; phosphors ; titania ; diethanolamine

**Identifiers:** KeyWord Plus(R): LOW-VOLTAGE CATHODOLUMINESCENCE; ACETIC-ACID; PARTICLES; TIO<sub>2</sub>; DEGRADATION; MECHANISM; ADHESION; SURFACES; POWDERS; UNIFORM

7/8/558 (Item 229 from file: 34)

SciSearch(R) Cited Ref Sci

(c) 2010 The Thomson Corp. All rights reserved.

18042180 **Genuine Article#:** 321DE **Number of References:** 43

**Title:** Silica-/titania-coated Y<sub>2</sub>O<sub>3</sub> : Tm<sup>3+</sup>, Yb<sup>3+</sup> nanoparticles with improvement in upconversion luminescence induced by different thickness shells ( ABSTRACT AVAILABLE )

**Publication date:** 20080615

**Journal Subject Category:** PHYSICS, APPLIED

**Identifiers:** KeyWord Plus(R): RESOLVED FLUOROMETRIC APPLICATION; RARE-EARTH IONS; SOL-GEL; SURFACE MODIFICATION; NANOCRYSTALS; CORE; MONODISPERSE; FLUORESCENCE; SPECTROSCOPY; PARTICLES

7/8/559 (Item 230 from file: 34)

SciSearch(R) Cited Ref Sci

(c) 2010 The Thomson Corp. All rights reserved.

18007869 **Genuine Article#:** 318GY **Number of References:** 39

**Title:** Kinetics and mechanism of hydroxyl radical formation studied via electron spin resonance for photocatalytic nanocrystalline titania: Effect of particle size distribution, concentration, and agglomeration ( ABSTRACT AVAILABLE )

**Publication date:** 20080000

**Journal Subject Category:** MATERIALS SCIENCE, CERAMICS

**Descriptors:** SCIAuthor Keywords: nanoparticles ; titanium dioxide (TiO<sub>2</sub>) ; agglomerate ; photocatalysis ; hydroxyl radical ; ESR

**Identifiers:** KeyWord Plus(R): TIO<sub>2</sub> PARTICLES; ESCHERICHIA-COLI; WATER;

## Appendix A-5. Irrelevant Titles

OXIDATION; HYDROGEN; DIOXIDE; ANATASE; PHOTOELECTROLYSIS;  
INACTIVATION; MOLECULES

7/8/560 (Item 231 from file: 34)

SciSearch(R) Cited Ref Sci

(c) 2010 The Thomson Corp. All rights reserved.

18002273 **Genuine Article#:** 317UK **Number of References:** 26

**Title:** Nanostructured titania-diphosphonate hybrid materials with a porous hierarchy  
( ABSTRACT AVAILABLE )

**Publication date:** 20080600

**Journal Subject Category:** CHEMISTRY, INORGANIC & NUCLEAR

**Descriptors:** SCIAuthor Keywords: nanostructure ; titanium phosphonates ; hierarchical porosity ; organic-inorganic hybrids ; self-assembly

**Identifiers:** KeyWord Plus(R): COUPLING MOLECULES; PHOSPHONATE;  
TITANIUM(IV); DERIVATIVES; PHOSPHATES; ADSORPTION; NANORODS;  
SILICA; TIO2; PORE

7/8/561 (Item 232 from file: 34)

SciSearch(R) Cited Ref Sci

(c) 2010 The Thomson Corp. All rights reserved.

18001792 **Genuine Article#:** 318HW **Number of References:** 52

**Title:** Titanium dioxide nanoparticles trigger p53-mediated damage response in peripheral blood lymphocytes ( ABSTRACT AVAILABLE )

**Publication date:** 20080600

**Journal Subject Category:** ENVIRONMENTAL SCIENCES; GENETICS & HEREDITY;  
TOXICOLOGY

**Descriptors:** SCIAuthor Keywords: titanium dioxide nanoparticles ; micronuclei ; single-cell gel electrophoresis ; p53 damage ; response ; ROS

**Identifiers:** KeyWord Plus(R): IN-VITRO TOXICITY; OXIDATIVE STRESS;  
ALVEOLAR MACROPHAGES; ULTRAFINE PARTICLES; DNA-DAMAGE;  
MICRONUCLEUS TECHNIQUE; APOPTOSIS; CELLS; RATS; P53

7/8/562 (Item 233 from file: 34)

SciSearch(R) Cited Ref Sci

(c) 2010 The Thomson Corp. All rights reserved.

17996065 **Genuine Article#:** 319PM **Number of References:** 15

**Title:** Controllable synthesis of titania nanocrystals with different morphologies and application to the degradation of phenol ( ABSTRACT AVAILABLE )

**Publication date:** 20080500

**Journal Subject Category:** CHEMISTRY, MULTIDISCIPLINARY

**Descriptors:** SCIAuthor Keywords: TiO2 ; hydrothermal synthesis ; nanoparticle ; anatase ; phenol degradation

**Identifiers:** KeyWord Plus(R): ANATASE; BROOKITE; RUTILE; TIO2; FILM

## Appendix A-5. Irrelevant Titles

7/8/563 (Item 234 from file: 34)

SciSearch(R) Cited Ref Sci

(c) 2010 The Thomson Corp. All rights reserved.

17975621 **Genuine Article#:** 314NV **Number of References:** 6

**Title:** Synthesis, characterization, and electrochemical properties of a thin flake titania fabricated from exfoliated nanosheets ( ABSTRACT AVAILABLE )

**Publication date:** 20080500

**Journal Subject Category:** CHEMISTRY, MULTIDISCIPLINARY; PHYSICS, CONDENSED MATTER

**Descriptors:** SCIAuthor Keywords: inorganic compounds ; oxides ; chemical synthesis ; electrochemical properties

**Identifiers:** KeyWord Plus(R): LAYERED TITANATE; FILMS

7/8/564 (Item 235 from file: 34)

SciSearch(R) Cited Ref Sci

(c) 2010 The Thomson Corp. All rights reserved.

17975394 **Genuine Article#:** 314AC **Number of References:** 47

**Title:** The photocatalytic activity of TiO<sub>2</sub> foam and surface modified binary oxide titania nanoparticles ( ABSTRACT AVAILABLE )

**Publication date:** 20080625

**Journal Subject Category:** CHEMISTRY, PHYSICAL

**Descriptors:** SCIAuthor Keywords: foam ; spectroscopy ; composites ; nanoparticles ; X-ray diffraction ; SEM microscopy

**Identifiers:** KeyWord Plus(R): AZO-DYE DEGRADATION; THIN-FILMS; HETEROGENEOUS PHOTOCATALYSIS; WATER-TREATMENT; METHYL-ORANGE; PHOTOOXIDATION; OXIDATION; DIOXIDE; PHASE; DECOLORIZATION

7/8/566 (Item 237 from file: 34)

SciSearch(R) Cited Ref Sci

(c) 2010 The Thomson Corp. All rights reserved.

17958760 **Genuine Article#:** 315VY **Number of References:** 51

**Title:** Enhancing photocatalytic activity of polymorphic titania nanoparticles by NMP solvent-based ambient condition process ( ABSTRACT AVAILABLE )

**Publication date:** 20080700

**Journal Subject Category:** CHEMISTRY, PHYSICAL

**Descriptors:** SCIAuthor Keywords: polymorphic titania ; solvothermal ; photocatalytic activity

**Identifiers:** KeyWord Plus(R): NITROGEN-DOPED TITANIA; ELECTRON-PARAMAGNETIC-RES; CONDITION SOL PROCESS; SOLVOTHERMAL PROCESS; TIO<sub>2</sub> NANOPARTICLES; PHASE-TRANSFORMATION; FIBROUS TITANIA; BROOKITE; POWDERS; ANATASE

## Appendix A-5. Irrelevant Titles

7/8/567 (Item 238 from file: 34)

SciSearch(R) Cited Ref Sci

(c) 2010 The Thomson Corp. All rights reserved.

17958376 **Genuine Article#:** 316IA **Number of References:** 61

**Title:** Titania encapsulation of flat gold nanoparticles - A simple route to Au@TiO<sub>2</sub> core-shell nanosheets ( ABSTRACT AVAILABLE )

**Publication date:** 20080700

**Journal Subject Category:** CHEMISTRY, MULTIDISCIPLINARY

**Descriptors:** SCIAuthor Keywords: core-shell ; titanium dioxide ; anisotropic nanoparticles ; semiconductor thin films ; nanocomposite material

**Identifiers:** KeyWord Plus(R): PHOTOCATALYTIC ACTIVITY; OXALIC-ACID; FERMI-LEVEL; TIO<sub>2</sub>; SILICA; METAL; SILVER; SIZE; NANOCOMPOSITES; NANOCRYSTALS

7/8/568 (Item 239 from file: 34)

SciSearch(R) Cited Ref Sci

(c) 2010 The Thomson Corp. All rights reserved.

17945340 **Genuine Article#:** 313AK **Number of References:** 36

**Title:** Sol-gel nanostructured titanium dioxide: Controlling the crystal structure, crystallite size, phase transformation, packing and ordering ( ABSTRACT AVAILABLE )

**Publication date:** 20080701

**Journal Subject Category:** CHEMISTRY, APPLIED; CHEMISTRY, PHYSICAL; NANOSCIENCE & NANOTECHNOLOGY; MATERIALS SCIENCE, MULTIDISCIPLINARY

**Descriptors:** SCIAuthor Keywords: titania ; sol-gel **processing** ; stability ; phase transformation ; peptisation ; drying

**Identifiers:** KeyWord Plus(R): POLYMERIC FUGITIVE AGENTS; NANOCRYSTALLINE ANATASE; THIN-FILMS; LOW-TEMPERATURE; TIO<sub>2</sub>; ROUTE; RUTILE; NANOPARTICLES; SULFATE; OXIDES

7/8/569 (Item 240 from file: 34)

SciSearch(R) Cited Ref Sci

(c) 2010 The Thomson Corp. All rights reserved.

17927909 **Genuine Article#:** 312XP **Number of References:** 19

**Title:** Interesting magnetic behavior from reduced titanium dioxide nanobelts ( ABSTRACT AVAILABLE )

**Publication date:** 20080609

**Journal Subject Category:** PHYSICS, APPLIED

**Identifiers:** KeyWord Plus(R): TIO<sub>2</sub>; FERROMAGNETISM; NANOTUBES; ESR

7/8/570 (Item 241 from file: 34)

SciSearch(R) Cited Ref Sci

## Appendix A-5. Irrelevant Titles

(c) 2010 The Thomson Corp. All rights reserved.

17924531 **Genuine Article#:** 310DM **Number of References:** 25

**Title:** Preparation of uniform titania nanocoating on ZnS-based phosphors by a sol-gel process ( ABSTRACT AVAILABLE )

**Publication date:** 20080602

**Journal Subject Category:** MATERIALS SCIENCE, MULTIDISCIPLINARY;  
MATERIALS SCIENCE, COATINGS & FILMS; PHYSICS, APPLIED; PHYSICS,  
CONDENSED MATTER

**Descriptors:** SCIAuthor Keywords: field emission display ; nanocoating ; phosphors ; sol-gel ; surface morphology ; titanium oxide ; zinc sulfide

**Identifiers:** KeyWord Plus(R): EMISSION DISPLAY PHOSPHORS; ZNS-AG,CL  
PHOSPHORS; ZINC-SULFIDE; NANOPARTICLES; DEGRADATION; PARTICLES;  
SILICA; OXIDE; TIO2

7/8/571 (Item 242 from file: 34)

SciSearch(R) Cited Ref Sci

(c) 2010 The Thomson Corp. All rights reserved.

17921030 **Genuine Article#:** 310NY **Number of References:** 41

**Title:** Morphology and catalytic application of homogeneous nano -composite oxides containing titania ( ABSTRACT AVAILABLE )

**Publication date:** 20080000

**Journal Subject Category:** ENERGY & FUELS; ENGINEERING, CHEMICAL;  
ENGINEERING, PETROLEUM

**Descriptors:** SCIAuthor Keywords: chromia ; hydrocracking ; hydrogenation ;  
hydrodesulfurization ; iron oxide ; nano-composite oxides ; titania

**Identifiers:** KeyWord Plus(R): GAS-OIL; HYDRODESULFURIZATION CATALYSTS;  
HYDROTREATING CATALYSTS; DEEP DESULFURIZATION; ALUMINA; HDS;  
NIMO; COMO; PHOTOCATALYSTS; ZEOLITE

7/8/572 (Item 243 from file: 34)

SciSearch(R) Cited Ref Sci

(c) 2010 The Thomson Corp. All rights reserved.

17919412 **Genuine Article#:** 309JG **Number of References:** 39

**Title:** Titania-germanium nanocomposite for photo-thermo-electric application ( ABSTRACT AVAILABLE )

**Publication date:** 20080702

**Journal Subject Category:** ENGINEERING, MULTIDISCIPLINARY; NANOSCIENCE  
& NANOTECHNOLOGY; MATERIALS SCIENCE, MULTIDISCIPLINARY; PHYSICS,  
APPLIED

**Identifiers:** KeyWord Plus(R): SMALL SEMICONDUCTOR CRYSTALLITES;  
ANATASE-RUTILE TRANSFORMATION; QUANTUM-DOT SUPERLATTICES;  
PHASE-TRANSFORMATION; SOLAR-CELL; VISIBLE PHOTOLUMINESCENCE;  
TIO2 NANOPARTICLES; GE MICROCRYSTALS; RAMAN; CONDUCTIVITY

## Appendix A-5. Irrelevant Titles

7/8/573 (Item 244 from file: 34)

SciSearch(R) Cited Ref Sci

(c) 2010 The Thomson Corp. All rights reserved.

17915057 **Genuine Article#:** 310AD **Number of References:** 9

**Title:** Smooth titania nanotubes: Self-organization and stabilization of anatase phase ( ABSTRACT AVAILABLE )

**Publication date:** 20080501

**Journal Subject Category:** MATERIALS SCIENCE, CERAMICS; MATERIALS SCIENCE, MULTIDISCIPLINARY

**Descriptors:** SCIAuthor Keywords: amorphous semiconductors ; nanocrystals ; electron diffraction/scattering ; TEM ; Raman spectroscopy ; short-range order

7/8/574 (Item 245 from file: 34)

SciSearch(R) Cited Ref Sci

(c) 2010 The Thomson Corp. All rights reserved.

17883728 **Genuine Article#:** 307JH **Number of References:** 41

**Title:** Genotoxic and cytotoxic potential of titanium dioxide (TiO<sub>2</sub>) nanoparticles on fish cells in vitro ( ABSTRACT AVAILABLE )

**Publication date:** 20080700

**Journal Subject Category:** ECOLOGY; ENVIRONMENTAL SCIENCES; TOXICOLOGY

**Descriptors:** SCIAuthor Keywords: nanoparticles ; genotoxicity ; cytotoxicity ; photo-genotoxicity ; RTG-2 cells ; comet assay ; micronucleus assay ; neutral red retention assay

**Identifiers:** KeyWord Plus(R): MICRONUCLEUS TECHNIQUE; OXIDATIVE DAMAGE; COMET ASSAY; DNA-DAMAGE; TOXICITY; PARTICLES; INDUCTION; DEGRADATION; SUNSCREENS; RISKS

7/8/575 (Item 246 from file: 34)

SciSearch(R) Cited Ref Sci

(c) 2010 The Thomson Corp. All rights reserved.

17846786 **Genuine Article#:** 301OM **Number of References:** 6

**Title:** Synthesis of nano titanium dioxide and its application in photocatalysis ( ABSTRACT AVAILABLE )

**Publication date:** 20080500

**Journal Subject Category:** PHYSICS, MULTIDISCIPLINARY

**Descriptors:** SCIAuthor Keywords: titania nanotubes ; microwave oven ; photocatalysis

7/8/576 (Item 247 from file: 34)

SciSearch(R) Cited Ref Sci

(c) 2010 The Thomson Corp. All rights reserved.

17832765 **Genuine Article#:** 302QZ **Number of References:** 24

**Title:** The comparison of Cu(II) adsorption capability of baker's yeast, nano-titania and their composite adsorbent ( ABSTRACT AVAILABLE )

## Appendix A-5. Irrelevant Titles

**Publication date:** 20080500

**Journal Subject Category:** MULTIDISCIPLINARY SCIENCES

**Descriptors:** SCIAuthor Keywords: nano-TiO<sub>2</sub> ; baker's yeast biomass ; composite adsorbent ; cooperative action ; active group

**Identifiers:** KeyWord Plus(R): HEAVY-METAL IONS; SOLID-PHASE EXTRACTION; WASTE-WATER; BEER YEAST; BIOSORPTION; COPPER; REDUCTION; INTERFACE; CATALYSTS; BEHAVIOR

7/8/577 (Item 248 from file: 34)

SciSearch(R) Cited Ref Sci

(c) 2010 The Thomson Corp. All rights reserved.

17821621 **Genuine Article#:** 301LE **Number of References:** 34

**Title:** Titanium dioxide nanoparticles assembled by DNA molecules hybridization and loading of DNA interacting proteins ( ABSTRACT AVAILABLE )

**Publication date:** 20080200

**Journal Subject Category:** NANOSCIENCE & NANOTECHNOLOGY; MATERIALS SCIENCE, MULTIDISCIPLINARY; PHYSICS, APPLIED

**Descriptors:** SCIAuthor Keywords: titanium dioxide nanoparticles ; DNA ; PCNA protein ; atomic force microscopy ; transmission electron microscopy ; assembly ; agarose ; nanoconjugate

**Identifiers:** KeyWord Plus(R): CELL NUCLEAR ANTIGEN; SENSITIZED SOLAR-CELLS; FORCE MICROSCOPY; PCNA; REPLICATION; BIOLOGY; SITES; SHELL; ACIDS

7/8/578 (Item 249 from file: 34)

SciSearch(R) Cited Ref Sci

(c) 2010 The Thomson Corp. All rights reserved.

17806152 **Genuine Article#:** 298VJ **Number of References:** 21

**Title:** Application of an empirical transport model to simulate retention of nanocrystalline titanium dioxide in sand columns ( ABSTRACT AVAILABLE )

**Publication date:** 20080400

**Journal Subject Category:** ENVIRONMENTAL SCIENCES

**Descriptors:** SCIAuthor Keywords: particle transport ; porous media ; passive chemical barrier ; TiO<sub>2</sub>

**Identifiers:** KeyWord Plus(R): SATURATED POROUS-MEDIA; TO-GRAIN CONTACTS; DEPOSITION; COLLOIDS; ATTACHMENT

7/8/579 (Item 250 from file: 34)

SciSearch(R) Cited Ref Sci

(c) 2010 The Thomson Corp. All rights reserved.

17806025 **Genuine Article#:** 299ZS **Number of References:** 9

**Title:** Photoelectrocatalytic degradation of methylene blue dye on titania nanotube

## Appendix A-5. Irrelevant Titles

**array film** ( ABSTRACT AVAILABLE )

**Publication date:** 20080405

**Journal Subject Category:** CHEMISTRY, MULTIDISCIPLINARY

**Identifiers:** KeyWord Plus(R): TIO2; FABRICATION; ELECTRODES; DIOXIDE

7/8/580 (Item 251 from file: 34)

SciSearch(R) Cited Ref Sci

(c) 2010 The Thomson Corp. All rights reserved.

17804290 **Genuine Article#:** 299ZD **Number of References:** 34

**Title: Enhanced photoelectrochemical method for linear DNA hybridization detection using Au-nanoparticle labeled DNA as probe onto titanium dioxide electrode** ( ABSTRACT AVAILABLE )

**Publication date:** 20080515

**Journal Subject Category:** BIOPHYSICS; BIOTECHNOLOGY & APPLIED MICROBIOLOGY; CHEMISTRY, ANALYTICAL ; ELECTROCHEMISTRY; NANOSCIENCE & NANOTECHNOLOGY

**Descriptors:** SCIAuthor Keywords: DNA ; sensor ; photoelectrochemical cell ; nanoparticles

**Identifiers:** KeyWord Plus(R): SIGNAL AMPLIFICATION; NANOPOROUS TIO2; CHARGE-TRANSFER; HOLE TRANSPORT; FILMS; NANOSTRUCTURES; BIOSENSORS; SENSORS

7/8/581 (Item 252 from file: 34)

SciSearch(R) Cited Ref Sci

(c) 2010 The Thomson Corp. All rights reserved.

17803845 **Genuine Article#:** 301GH **Number of References:** 36

**Title: Nano titanium dioxide photocatalytic protein tyrosine nitration: A potential hazard of TiO<sub>2</sub> on skin** ( ABSTRACT AVAILABLE )

**Publication date:** 20080613

**Journal Subject Category:** BIOCHEMISTRY & MOLECULAR BIOLOGY; BIOPHYSICS

**Descriptors:** SCIAuthor Keywords: nitrite ; protein nitration ; titanium dioxide ; UV exposure

**Identifiers:** KeyWord Plus(R): NITRIC-OXIDE; AQUEOUS-SOLUTION; CONTACT HYPERSENSITIVITY; MOUSE MODEL; OXIDATION; PEROXYNITRITE; DAMAGE; DEGRADATION; OXYGEN; WATER

7/8/582 (Item 253 from file: 34)

SciSearch(R) Cited Ref Sci

(c) 2010 The Thomson Corp. All rights reserved.

17777033 **Genuine Article#:** 297WU **Number of References:** 57

**Title: A novel electrogenerated chemiluminescence (ECL) sensor based on Ru(bpy)<sub>3</sub>(<sup>3</sup>2+)-doped titania nanoparticles dispersed in Nafion on glassy carbon electrode** ( ABSTRACT AVAILABLE )

**Publication date:** 20080400

## Appendix A-5. Irrelevant Titles

**Journal Subject Category:** CHEMISTRY, ANALYTICAL; ELECTROCHEMISTRY

**Descriptors:** SCIAuthor Keywords: electrogenerated chemiluminescence (ECL) sensor ; Ru(bpy)(3)(2+) ; titania nanoparticles ; Nafion film

**Identifiers:** KeyWord Plus(R): DOPED SILICA NANOPARTICLES; TIN OXIDE ELECTRODES; THIN-FILM; ELECTROCHEMILUMINESCENCE DETECTION; CAPILLARY-ELECTROPHORESIS; MULTILAYER FILMS; TIO2 PARTICLES; GEL MEMBRANE; MICROCHIP; EMISSION

7/8/583 (Item 254 from file: 34)

SciSearch(R) Cited Ref Sci

(c) 2010 The Thomson Corp. All rights reserved.

17766431 **Genuine Article#:** 295NO **Number of References:** 15

**Title:** Soft solution synthesis of a zinc oxide nano-screw superstructure and its composite with nitrogen-doped titania ( ABSTRACT AVAILABLE )

**Publication date:** 20080000

**Journal Subject Category:** CHEMISTRY, MULTIDISCIPLINARY

**Descriptors:** SCIAuthor Keywords: soft solution process ; ZnO nano-screw ; nitrogen-doped titania ; photocatalyst

**Identifiers:** KeyWord Plus(R): ROOM-TEMPERATURE; ZNO; NANOSTRUCTURES; PHOTOCATALYST; NANOBELTS; NANORINGS; FILMS

7/8/584 (Item 255 from file: 34)

SciSearch(R) Cited Ref Sci

(c) 2010 The Thomson Corp. All rights reserved.

17760877 **Genuine Article#:** 292WB **Number of References:** 12

**Title:** Photocatalytic decomposition of methylene nanocrystalline titania prepared by different blue on methods ( ABSTRACT AVAILABLE )

**Publication date:** 20080506

**Journal Subject Category:** MATERIALS SCIENCE, MULTIDISCIPLINARY

**Descriptors:** SCIAuthor Keywords: nanostructures ; sol-gel chemistry ; catalytic properties

**Identifiers:** KeyWord Plus(R): ANATASE; TIO2

7/8/585 (Item 256 from file: 34)

SciSearch(R) Cited Ref Sci

(c) 2010 The Thomson Corp. All rights reserved.

17755130 **Genuine Article#:** 295AO **Number of References:** 10

**Title:** Flash synthesis of titanium dioxide nanoparticles by strong exothermic reaction between solids without external energy ( ABSTRACT AVAILABLE )

**Publication date:** 20080508

**Journal Subject Category:** CHEMISTRY, PHYSICAL; MATERIALS SCIENCE, MULTIDISCIPLINARY; METALLURGY & METALLURGICAL ENGINEERING

**Descriptors:** SCIAuthor Keywords: nanofabrications ; oxide materials ; self-propagating high-temperature synthesis (SHS)

## Appendix A-5. Irrelevant Titles

7/8/586 (Item 257 from file: 34)

SciSearch(R) Cited Ref Sci

(c) 2010 The Thomson Corp. All rights reserved.

17721654 **Genuine Article#:** 290CK **Number of References:** 46

**Title: Effects of carboxylic acids on the microstructure and performance of titania nanocrystals ( ABSTRACT AVAILABLE )**

**Publication date:** 20080501

**Journal Subject Category:** ENGINEERING, CHEMICAL

**Descriptors:** SCIAuthor Keywords: titania ; hydrothermal **process** ; carboxylic acid ; chelate ; photocatalytic activity ; TiCl<sub>4</sub>

**Identifiers:** KeyWord Plus(R): ENHANCED PHOTOCATALYTIC ACTIVITY; VISIBLE-LIGHT IRRADIATION; GAS-PHASE PHOTOOXIDATION; AQUEOUS-SOLUTIONS; HYDROTHERMAL METHOD; TIO<sub>2</sub> PARTICLES; RUTILE TIO<sub>2</sub>; RHODAMINE-B; ANATASE; SURFACE

7/8/587 (Item 258 from file: 34)

SciSearch(R) Cited Ref Sci

(c) 2010 The Thomson Corp. All rights reserved.

17714063 **Genuine Article#:** 282WG **Number of References:** 23

**Title: Photocatalytic properties of titanium dioxide sputtered on a nanostructured substrate ( ABSTRACT AVAILABLE )**

**Publication date:** 20080303

**Journal Subject Category:** MATERIALS SCIENCE, MULTIDISCIPLINARY; MATERIALS SCIENCE, COATINGS & FILMS; PHYSICS, APPLIED; PHYSICS, CONDENSED MATTER

**Descriptors:** SCIAuthor Keywords: photocatalysis ; TiO<sub>2</sub> ; nanoporous alumina ; magnetron sputtering

**Identifiers:** KeyWord Plus(R): TIO<sub>2</sub> PARTICLES; POROUS ALUMINA; THIN-FILMS; MICROEMULSION; FABRICATION; OXIDATION; GLASS; ION

7/8/588 (Item 259 from file: 34)

SciSearch(R) Cited Ref Sci

(c) 2010 The Thomson Corp. All rights reserved.

17706932 **Genuine Article#:** 289UZ **Number of References:** 59

**Title: Hydroxyl radicals ((OH)-O-center dot) are associated with titanium dioxide (TiO<sub>2</sub>) nanoparticle-induced cytotoxicity and oxidative DNA damage in fish cells ( ABSTRACT AVAILABLE )**

**Publication date:** 20080402

**Journal Subject Category:** BIOTECHNOLOGY & APPLIED MICROBIOLOGY; GENETICS & HEREDITY; TOXICOLOGY

**Descriptors:** SCIAuthor Keywords: titanium dioxide ; nanoparticles ; UVA ; oxidative stress ; DNA damage ; ESR

**Identifiers:** KeyWord Plus(R): COMET ASSAY; AQUATIC ORGANISMS; ULTRAVIOLET-RADIATION; EPITHELIAL-CELLS; POTENTIAL VALUE; SINGLET

## Appendix A-5. Irrelevant Titles

OXYGEN; BASE DAMAGE; IN-VITRO; PARTICLES; STRESS

7/8/589 (Item 260 from file: 34)

SciSearch(R) Cited Ref Sci

(c) 2010 The Thomson Corp. All rights reserved.

17678248 **Genuine Article#:** 286AL **Number of References:** 32

**Title:** Preparation and corrosion protective properties of nanostructured titania-containing hybrid sol-gel coatings on AA2024 ( ABSTRACT AVAILABLE )

**Publication date:** 20080400

**Journal Subject Category:** CHEMISTRY, APPLIED; MATERIALS SCIENCE, COATINGS & FILMS

**Descriptors:** SCIAuthor Keywords: hybrid coating ; sol-gel ; corrosion ; EIS ; AA2024

**Identifiers:** KeyWord Plus(R): CHROMATE CONVERSION COATINGS; ALUMINUM-ALLOYS; THIN-FILMS

7/8/590 (Item 261 from file: 34)

SciSearch(R) Cited Ref Sci

(c) 2010 The Thomson Corp. All rights reserved.

17667551 **Genuine Article#:** 286PL **Number of References:** 30

**Title:** State-sensitive monitoring of gold nanoparticle sites on titania and the interaction of the positive Au site with O-2 by Au L alpha 1-selecting X-ray absorption fine structure ( ABSTRACT AVAILABLE )

**Publication date:** 20080303

**Journal Subject Category:** CHEMISTRY, INORGANIC & NUCLEAR

**Descriptors:** SCIAuthor Keywords: gold ; titanium oxide ; X-ray absorption fine structure ; fluorescence spectrometry ; chemical state

**Identifiers:** KeyWord Plus(R): STRUCTURE XAFS SPECTROSCOPY; SURFACE-ACTIVE SITES; FLUORESCENCE SPECTROMETRY; CO OXIDATION; CATALYTIC-ACTIVITY; SELECTIVE XAFS; ADSORPTION; TIO2; DEPOSITION; TIO2(110)

7/8/593 (Item 264 from file: 34)

SciSearch(R) Cited Ref Sci

(c) 2010 The Thomson Corp. All rights reserved.

17645611 **Genuine Article#:** 284MP **Number of References:** 27

**Title:** Diffusion-controlled self-assembly and dendrite formation in silver-seeded anatase titania nanospheres ( ABSTRACT AVAILABLE )

**Publication date:** 20080410

**Journal Subject Category:** CHEMISTRY, PHYSICAL; NANOSCIENCE & NANOTECHNOLOGY; MATERIALS SCIENCE, MULTIDISCIPLINARY

**Identifiers:** KeyWord Plus(R): SURFACE SCIENCE; POROUS-SILICON; OXIDE HYDRATE; TRANSFORMATION

## Appendix A-5. Irrelevant Titles

7/8/594 (Item 265 from file: 34)

SciSearch(R) Cited Ref Sci

(c) 2010 The Thomson Corp. All rights reserved.

17642364 **Genuine Article#:** 282UY **Number of References:** 23

**Title:** Structural effects of codoping of Nb and Sc in titanium dioxide nanoparticles ( ABSTRACT AVAILABLE )

**Publication date:** 20080200

**Journal Subject Category:** CHEMISTRY, INORGANIC & NUCLEAR

**Descriptors:** SCIAuthor Keywords: TiO<sub>2</sub> ; nanostructures ; sol-gel processes ; calcination ; niobium ; scandium

**Identifiers:** KeyWord Plus(R): DOPED TIO<sub>2</sub> NANOPARTICLES; PHOTOCATALYTIC DEGRADATION; ANATASE; TRANSFORMATION; PHENOL

7/8/595 (Item 266 from file: 34)

SciSearch(R) Cited Ref Sci

(c) 2010 The Thomson Corp. All rights reserved.

17630653 **Genuine Article#:** 279GG **Number of References:** 17

**Title:** Preparation of anatase, rutile and brookite type anion doped titania photocatalyst nanoparticles and thin films ( ABSTRACT AVAILABLE )

**Publication date:** 20071200

**Journal Subject Category:** PHYSICS, MULTIDISCIPLINARY

**Identifiers:** KeyWord Plus(R): TIO<sub>2</sub>; DIOXIDE; PHASE; WATER

7/8/596 (Item 267 from file: 34)

SciSearch(R) Cited Ref Sci

(c) 2010 The Thomson Corp. All rights reserved.

17627604 **Genuine Article#:** 281EU **Number of References:** 52

**Title:** Effect of carbon doping on the mesoporous structure of nanocrystalline titanium dioxide and its solar-light-driven photocatalytic degradation of NO<sub>x</sub> ( ABSTRACT AVAILABLE )

**Publication date:** 20080401

**Journal Subject Category:** CHEMISTRY, PHYSICAL

**Identifiers:** KeyWord Plus(R): INDOOR AIR PURIFICATION; DOPED TIO<sub>2</sub> PHOTOCATALYSTS; VISIBLE-LIGHT; ACTIVATED CARBON; LOCAL STRUCTURES; DECOMPOSITION; PHOTODEGRADATION; OXIDATION; POLLUTANTS; REDUCTION

7/8/597 (Item 268 from file: 34)

SciSearch(R) Cited Ref Sci

(c) 2010 The Thomson Corp. All rights reserved.

17620667 **Genuine Article#:** 281BR **Number of References:** 29

**Title:** Rapid synthesis of titania nanowires by microwave-assisted hydrothermal treatments ( ABSTRACT AVAILABLE )

## Appendix A-5. Irrelevant Titles

**Publication date:** 20080402

**Journal Subject Category:** ENGINEERING, CHEMICAL

**Identifiers:** KeyWord Plus(R): SONOCHEMICAL SYNTHESIS; OXIDE NANOTUBES; ANATASE TIO<sub>2</sub>; RUTILE

7/8/598 (Item 269 from file: 34)

SciSearch(R) Cited Ref Sci

(c) 2010 The Thomson Corp. All rights reserved.

17583996 **Genuine Article#:** 277UW **Number of References:** 22

**Title:** Tissue distribution and toxicity of intravenously administered titanium dioxide nanoparticles in rats ( ABSTRACT AVAILABLE )

**Publication date:** 20080300

**Journal Subject Category:** TOXICOLOGY

**Descriptors:** SCIAuthor Keywords: nano-TiO<sub>2</sub> ; tissue distribution ; adverse effects ; toxicokinetics ; cytokines

**Identifiers:** KeyWord Plus(R): PARTICLES; INHALATION; RESPONSES; MICE

7/8/599 (Item 270 from file: 34)

SciSearch(R) Cited Ref Sci

(c) 2010 The Thomson Corp. All rights reserved.

17578250 **Genuine Article#:** 274YO **Number of References:** 29

**Title:** Spectral effects in laser induced incandescence application to flame-made titania nanoparticles ( ABSTRACT AVAILABLE )

**Publication date:** 20080200

**Journal Subject Category:** SPECTROSCOPY

**Descriptors:** SCIAuthor Keywords: laser induced incandescence ; combustion diagnostics ; flame synthesis ; titania nanoparticles

**Identifiers:** KeyWord Plus(R): PHASE COMBUSTION SYNTHESIS; PARTICLE SYNTHESIS; DIFFUSION FLAME; SURROUNDING GAS; TIO<sub>2</sub> PARTICLES; NANO-PARTICLES; SIZE; REACTORS; SOOT; LII

7/8/600 (Item 271 from file: 34)

SciSearch(R) Cited Ref Sci

(c) 2010 The Thomson Corp. All rights reserved.

17561380 **Genuine Article#:** 271MA **Number of References:** 37

**Title:** Photocatalytic H<sub>2</sub> production from methanol aqueous solution over titania nanoparticles with mesostructures ( ABSTRACT AVAILABLE )

**Publication date:** 20080100

**Journal Subject Category:** CHEMISTRY, PHYSICAL; ENERGY & FUELS; ENVIRONMENTAL SCIENCES; PHYSICS, ATOMIC, MOLECULAR & CHEMICAL

**Descriptors:** SCIAuthor Keywords: photocatalytic activity ; titania ; mesostructured nanoparticles ; hydrogen production

**Identifiers:** KeyWord Plus(R): TIO<sub>2</sub> SUSPENSIONS; PHOTO-FENTON; WATER;

## Appendix A-5. Irrelevant Titles

DEGRADATION; OXIDATION; HYDROGEN; DIOXIDE; SYSTEMS;  
DECOMPOSITION; SPECTROSCOPY

7/8/601 (Item 272 from file: 34)

SciSearch(R) Cited Ref Sci

(c) 2010 The Thomson Corp. All rights reserved.

17558338 **Genuine Article#:** 274VD **Number of References:** 19

**Title:** Vertically oriented titania nanotubes prepared by anodic oxidation on Si substrates ( ABSTRACT AVAILABLE )

**Publication date:** 20080300

**Journal Subject Category:** ENGINEERING, ELECTRICAL & ELECTRONIC;  
NANOSCIENCE & NANOTECHNOLOGY; MATERIALS SCIENCE,  
MULTIDISCIPLINARY; PHYSICS, APPLIED

**Descriptors:** SCIAuthor Keywords: anodization ; aqueous electrolyte ; nanotube arrays ; thin film ; titania

**Identifiers:** KeyWord Plus(R): POROUS ALUMINA MEMBRANES; TIO2  
NANOTUBES; FABRICATION; ANODIZATION; ARRAYS

7/8/602 (Item 273 from file: 34)

SciSearch(R) Cited Ref Sci

(c) 2010 The Thomson Corp. All rights reserved.

17550937 **Genuine Article#:** 271PC **Number of References:** 45

**Title:** A one-pot approach to hierarchically nanoporous titania hollow microspheres with high photocatalytic activity ( ABSTRACT AVAILABLE )

**Publication date:** 20080300

**Journal Subject Category:** CHEMISTRY, MULTIDISCIPLINARY;  
CRYSTALLOGRAPHY; MATERIALS SCIENCE, MULTIDISCIPLINARY

**Identifiers:** KeyWord Plus(R): LIQUID-PHASE DEPOSITION; MACRO-/MESOPOROUS  
TITANIA; TIO2 THIN-FILMS; MESOPOROUS TITANIA; CALCINATION  
TEMPERATURE; SELF-TRANSFORMATION; SILICA MICROSPHERES;  
HYDROTHERMAL METHOD; METHYLENE-BLUE; SURFACE-AREA

7/8/603 (Item 274 from file: 34)

SciSearch(R) Cited Ref Sci

(c) 2010 The Thomson Corp. All rights reserved.

17548447 **Genuine Article#:** 273WA **Number of References:** 25

**Title:** One-pot synthesis of Ni-nanoparticle-embedded mesoporous titania/silica catalyst and its application for CO<sub>2</sub>-reforming of methane ( ABSTRACT AVAILABLE )

**Publication date:** 20080331

**Journal Subject Category:** CHEMISTRY, PHYSICAL

**Descriptors:** SCIAuthor Keywords: Ni/TiO<sub>2</sub>-SiO<sub>2</sub> catalyst ; sol-gel ; CO<sub>2</sub>-reforming of methane

**Identifiers:** KeyWord Plus(R): CARBON-DIOXIDE; NI/AL<sub>2</sub>O<sub>3</sub> CATALYSTS;

## Appendix A-5. Irrelevant Titles

SYNTHESIS GAS; CO<sub>2</sub>; NICKEL; OXIDE; SUPPORT; SILICA; MCM-41

7/8/604 (Item 275 from file: 34)

SciSearch(R) Cited Ref Sci

(c) 2010 The Thomson Corp. All rights reserved.

17540345 **Genuine Article#:** 271IX **Number of References:** 15

**Title: Determination of trace gold by flame atomic absorption spectrometry after separation and preconcentration with load nanometer titanium dioxide ( ABSTRACT AVAILABLE )**

**Publication date:** 20080200

**Journal Subject Category:** SPECTROSCOPY

**Descriptors:** SCIAuthor Keywords: nanometer TiO<sub>2</sub> ; p-dimethylaminobenzylidenerhodanine ; **separation** and preconcentration ; FAAS ; gold

**Identifiers:** KeyWord Plus(R): ADSORPTION BEHAVIOR; ICP-AES; PLATINUM; RESIN

7/8/605 (Item 276 from file: 34)

SciSearch(R) Cited Ref Sci

(c) 2010 The Thomson Corp. All rights reserved.

17540144 **Genuine Article#:** 270QW **Number of References:** 27

**Title: Titania-germanium nanocomposite as a photovoltaic material ( ABSTRACT AVAILABLE )**

**Publication date:** 20080000

**Journal Subject Category:** ENERGY & FUELS

**Identifiers:** KeyWord Plus(R): SMALL SEMICONDUCTOR CRYSTALLITES; DOT SOLAR-CELLS; VISIBLE PHOTOLUMINESCENCE; SiO<sub>2</sub> MATRIX; QUANTUM; ELECTRON; MODEL

7/8/606 (Item 277 from file: 34)

SciSearch(R) Cited Ref Sci

(c) 2010 The Thomson Corp. All rights reserved.

17528717 **Genuine Article#:** 271BF **Number of References:** 21

**Title: The effect of particle size and crystal structure of titanium dioxide nanoparticles on the photocatalytic properties ( ABSTRACT AVAILABLE )**

**Publication date:** 20080000

**Journal Subject Category:** ENGINEERING, ENVIRONMENTAL; ENVIRONMENTAL SCIENCES

**Descriptors:** SCIAuthor Keywords: advanced oxidation **processes** (AOPs) ; heterogeneous photocatalysis ; TiO<sub>2</sub> nanoparticles ; crystalline structure ; nanoparticles size ; decolorization ; C. I. acid red 88

**Identifiers:** KeyWord Plus(R): AZO-DYE; AQUEOUS SUSPENSIONS; DEGRADATION; TiO<sub>2</sub>; ZNO; PHOTODEGRADATION; MINERALIZATION

## Appendix A-5. Irrelevant Titles

7/8/607 (Item 278 from file: 34)

SciSearch(R) Cited Ref Sci

(c) 2010 The Thomson Corp. All rights reserved.

17501371 **Genuine Article#:** 265XG **Number of References:** 54

**Title:** Preparation of organoclay having titania nano-crystals in interlayer hydrophobic field and its characterization ( ABSTRACT AVAILABLE )

**Publication date:** 20080200

**Journal Subject Category:** MATERIALS SCIENCE, CERAMICS

**Descriptors:** SCIAuthor Keywords: **environmental** clean-up material ; photocatalytic decomposition ; organoclay ; Titania nanocrystals ; hybridization ; **toxic** organic compounds

**Identifiers:** KeyWord Plus(R): ALUMINA-PILLARED CLAY; SELECTIVE CATALYTIC-REDUCTION; ANATASE TIO2 NANOPARTICLES; GEL-SOL METHOD; ADSORPTION PROPERTIES; MONTMORILLONITE CLAY; POLYVINYL-ALCOHOL; IRON-OXIDE; N-OCTANE; WATER

7/8/608 (Item 279 from file: 34)

SciSearch(R) Cited Ref Sci

(c) 2010 The Thomson Corp. All rights reserved.

17486699 **Genuine Article#:** 265KU **Number of References:** 24

**Title:** Effect of trimethylamine on the formation of anatase titania nanoparticles by gel-sol method ( ABSTRACT AVAILABLE )

**Publication date:** 20080200

**Journal Subject Category:** CHEMISTRY, PHYSICAL

**Identifiers:** KeyWord Plus(R): TIO2 NANOPARTICLES; SHAPE CONTROL; PARTICLES; PHOTOCATALYSIS; MECHANISM; CRYSTALS

7/8/609 (Item 280 from file: 34)

SciSearch(R) Cited Ref Sci

(c) 2010 The Thomson Corp. All rights reserved.

17485098 **Genuine Article#:** 265SV **Number of References:** 53

**Title:** Preparation and photocatalytic activity of nanotubes obtained from titanium dioxide ( ABSTRACT AVAILABLE )

**Publication date:** 20080229

**Journal Subject Category:** CHEMISTRY, APPLIED; CHEMISTRY, PHYSICAL; ENGINEERING, CHEMICAL

**Descriptors:** SCIAuthor Keywords: TiO2 ; titanates ; nanotubes ; hydrothermal **process** ; photocatalytic activity

**Identifiers:** KeyWord Plus(R): EXCHANGEABLE TITANATE NANOTUBES; GAS-PHASE PHOTOOXIDATION; TIO2 NANOTUBES; NANOSTRUCTURED TIO2; STRUCTURAL FEATURES; OXIDE NANOTUBE; NANOCRYSTALS; TEMPERATURE; CATALYSTS; ANATASE

## Appendix A-5. Irrelevant Titles

7/8/610 (Item 281 from file: 34)

SciSearch(R) Cited Ref Sci

(c) 2010 The Thomson Corp. All rights reserved.

17463988 **Genuine Article#:** 261SK **Number of References:** 23

**Title:** A plasmonic photocatalyst consisting of silver nanoparticles embedded in titanium dioxide ( ABSTRACT AVAILABLE )

**Publication date:** 20080206

**Journal Subject Category:** CHEMISTRY, MULTIDISCIPLINARY

**Identifiers:** KeyWord Plus(R): TIO2 POWDER; THIN-FILMS; DECOMPOSITION; SUBSTRATE; SILVER

7/8/611 (Item 282 from file: 34)

SciSearch(R) Cited Ref Sci

(c) 2010 The Thomson Corp. All rights reserved.

17430575 **Genuine Article#:** 259HJ **Number of References:** 12

**Title:** Formation of titania nanoarrays by hydrothermal reaction and their application in photovoltaic cells ( ABSTRACT AVAILABLE )

**Publication date:** 20080200

**Journal Subject Category:** MATERIALS SCIENCE, CERAMICS

**Identifiers:** KeyWord Plus(R): SENSITIZED SOLAR-CELLS; ARRAYS; NANOTUBES; FILMS

7/8/612 (Item 283 from file: 34)

SciSearch(R) Cited Ref Sci

(c) 2010 The Thomson Corp. All rights reserved.

17430306 **Genuine Article#:** 258NR **Number of References:** 22

**Title:** Role of surface-purity in photocatalytic activity of nanocrystalline anatase-titania processed via polymer-modified sol-gel ( ABSTRACT AVAILABLE )

**Publication date:** 20080200

**Journal Subject Category:** MATERIALS SCIENCE, CERAMICS

**Descriptors:** SCIAuthor Keywords: hydroxypropyl cellulose ; nanocrystalline ; photocatalysis ; sol-gel ; titania

**Identifiers:** KeyWord Plus(R): DEGRADATION; CARBON; NANOPARTICLES; PROPERTY; SIZE; FTIR; FILM; NANO

7/8/613 (Item 284 from file: 34)

SciSearch(R) Cited Ref Sci

(c) 2010 The Thomson Corp. All rights reserved.

17430035 **Genuine Article#:** 253IY **Number of References:** 32

**Title:** High dispersion and electrocatalytic activity of Pd/titanium dioxide nanotubes catalysts for hydrazine oxidation ( ABSTRACT AVAILABLE )

**Publication date:** 20080103

**Journal Subject Category:** ELECTROCHEMISTRY; ENERGY & FUELS

## Appendix A-5. Irrelevant Titles

**Descriptors:** SCIAuthor Keywords: titanium dioxide nanotubes ; Pd nanoparticles ; supporting materials ; hydrazine oxidation

**Identifiers:** KeyWord Plus(R): WALLED CARBON NANOTUBES; FUEL-CELLS; METHANOL ELECTROOXIDATION; PALLADIUM NANOPARTICLES; PLATINUM; NANOCOMPOSITES; PERFORMANCE; ELECTRODES; SUPPORT; ETHANOL

7/8/614 (Item 285 from file: 34)

SciSearch(R) Cited Ref Sci

(c) 2010 The Thomson Corp. All rights reserved.

17422482 **Genuine Article#:** 260UU **Number of References:** 22

**Title:** Precipitation of nanosized titanium dioxide from aqueous titanium (IV) chloride solutions by neutralization with MgO ( ABSTRACT AVAILABLE )

**Publication date:** 20080100

**Journal Subject Category:** METALLURGY & METALLURGICAL ENGINEERING

**Descriptors:** SCIAuthor Keywords: titanium dioxide ; preparation ; magnesium oxide ; titanium tetrachloride ; hydrolysis ; neutralization ; recovery

**Identifiers:** KeyWord Plus(R): TIO2 NANOPARTICLES; ANATASE; RUTILE; PARTICLES; TICL4; GEL; TETRAISOPROPOXIDE; HYDROLYSIS; POWDERS

7/8/615 (Item 286 from file: 34)

SciSearch(R) Cited Ref Sci

(c) 2010 The Thomson Corp. All rights reserved.

17384549 **Genuine Article#:** 254CN **Number of References:** 35

**Title:** Influence of particle temperature and velocity on the microstructure and mechanical behaviour of high velocity oxy-fuel (HVOF)-sprayed nanostructured titania coatings ( ABSTRACT AVAILABLE )

**Publication date:** 20080303

**Journal Subject Category:** ENGINEERING, INDUSTRIAL; ENGINEERING, MANUFACTURING; MATERIALS SCIENCE, MULTIDISCIPLINARY

**Descriptors:** SCIAuthor Keywords: thermal spray ; high velocity oxy-fuel (HVOF) ; in-flight particle diagnostics ; nanostructured titania (TiO<sub>2</sub>) ; microstructure ; bond strength

**Identifiers:** KeyWord Plus(R): PLASMA-SPRAYED COATINGS; POROUS HYDROXYAPATITE; NANOPHASE CERAMICS; RESIDUAL-STRESS; POWDERS; COMPONENTS; ALUMINA

7/8/616 (Item 287 from file: 34)

SciSearch(R) Cited Ref Sci

(c) 2010 The Thomson Corp. All rights reserved.

17351719 **Genuine Article#:** 254PM **Number of References:** 35

**Title:** Automated phosphoproteome analysis for cultured cancer cells by two-dimensional nanoLC-MS using a calcined titania/C18 biphasic column ( ABSTRACT AVAILABLE )

**Publication date:** 20080100

## Appendix A-5. Irrelevant Titles

**Journal Subject Category:** CHEMISTRY, ANALYTICAL

**Identifiers:** KeyWord Plus(R): TANDEM MASS-SPECTROMETRY; SWITCHING HPLC ANALYSIS; AFFINITY-CHROMATOGRAPHY; PHOSHOPEPTIDE ENRICHMENT; LIQUID-CHROMATOGRAPHY; PHOSPHORYLATION ANALYSIS; CHEMO-AFFINITY; IN-VIVO; PROTEOMICS; PEPTIDES

7/8/617 (Item 288 from file: 34)

SciSearch(R) Cited Ref Sci

(c) 2010 The Thomson Corp. All rights reserved.

17350154 **Genuine Article#:** 257DX **Number of References:** 18

**Title:** Synergistic effects of microwave doped Ag on the phase transformation and photocatalytic activity of nano-titania ( ABSTRACT AVAILABLE )

**Publication date:** 20080114

**Journal Subject Category:** CHEMISTRY, MULTIDISCIPLINARY

**Descriptors:** SCIAuthor Keywords: nano-titania ; Ag dopant ; microwave ; phase transformation ; photocatalytic activity

**Identifiers:** KeyWord Plus(R): AQUEOUS TIO2 SUSPENSIONS; DEGRADATION; REDUCTION

7/8/618 (Item 289 from file: 34)

SciSearch(R) Cited Ref Sci

(c) 2010 The Thomson Corp. All rights reserved.

17337558 **Genuine Article#:** 252YC **Number of References:** 31

**Title:** Methods for functionalization of microsized polystyrene beads with titania nanoparticles for cathodic electrophoretic deposition ( ABSTRACT AVAILABLE )

**Publication date:** 20080215

**Journal Subject Category:** CHEMISTRY, PHYSICAL

**Descriptors:** SCIAuthor Keywords: heterocoagulation ; coating ; macroporosity ; template ; polyelectrolyte

**Identifiers:** KeyWord Plus(R): HOLLOW SPHERES; TEMPLATES; PARTICLES; ELECTRODEPOSITION; FABRICATION; CERAMICS; CRYSTALS; SURFACES; COLLOIDS; COATINGS

7/8/619 (Item 290 from file: 34)

SciSearch(R) Cited Ref Sci

(c) 2010 The Thomson Corp. All rights reserved.

17297904 **Genuine Article#:** 248XK **Number of References:** 6

**Title:** Production of titanium dioxide nanoparticles by combustion of liquid titanium droplets ( ABSTRACT AVAILABLE )

**Publication date:** 20070000

**Journal Subject Category:** ENGINEERING, CHEMICAL

## Appendix A-5. Irrelevant Titles

7/8/620 (Item 291 from file: 34)

SciSearch(R) Cited Ref Sci

(c) 2010 The Thomson Corp. All rights reserved.

17288708 **Genuine Article#:** 246ZW **Number of References:** 33

**Title:** Crystal morphology of anatase titania nanocrystals used in dye-sensitized solar cells ( ABSTRACT AVAILABLE )

**Publication date:** 20080100

**Journal Subject Category:** CHEMISTRY, MULTIDISCIPLINARY;  
CRYSTALLOGRAPHY; MATERIALS SCIENCE, MULTIDISCIPLINARY

**Identifiers:** KeyWord Plus(R): TIO2 FILMS; ELECTRON-TRANSPORT; GRAIN MORPHOLOGY; RECOMBINATION; PERFORMANCE; CONVERSION; DIFFUSION; INSIGHTS; GROWTH; RUTILE

7/8/621 (Item 292 from file: 34)

SciSearch(R) Cited Ref Sci

(c) 2010 The Thomson Corp. All rights reserved.

17262055 **Genuine Article#:** 245FA **Number of References:** 21

**Title:** Polymethylmethacrylate-grafted titanium dioxide nanoparticles prepared via radical polymerization ( ABSTRACT AVAILABLE )

**Publication date:** 20080100

**Journal Subject Category:** MATERIALS SCIENCE, MULTIDISCIPLINARY

**Identifiers:** KeyWord Plus(R): SOLID SUBSTRATE; PARTICLES; SURFACE; ENCAPSULATION; TIO2; FILLERS; HYBRID; PMMA

7/8/622 (Item 293 from file: 34)

SciSearch(R) Cited Ref Sci

(c) 2010 The Thomson Corp. All rights reserved.

17260092 **Genuine Article#:** 246GM **Number of References:** 22

**Title:** Experimental study of the photocatalytic degradation of formaldehyde in indoor air using a nano-particulate titanium dioxide photocatalyst ( ABSTRACT AVAILABLE )

**Publication date:** 20071200

**Journal Subject Category:** CONSTRUCTION & BUILDING TECHNOLOGY;  
ENGINEERING, ENVIRONMENTAL; PUBLIC, ENVIRONMENTAL &  
OCCUPATIONAL HEALTH

**Descriptors:** SCIAuthor Keywords: nano ; TiO2 ; photocatalysis ; formaldehyde ; experiment

**Identifiers:** KeyWord Plus(R): VOLATILE ORGANIC-COMPOUNDS;  
HETEROGENEOUS PHOTOCATALYSIS; GAS-PHASE; TIO2; OXIDATION;  
TRICHLOROETHYLENE; PURIFICATION; TOLUENE; VOCs; INHIBITION

7/8/623 (Item 294 from file: 34)

SciSearch(R) Cited Ref Sci

## Appendix A-5. Irrelevant Titles

(c) 2010 The Thomson Corp. All rights reserved.

17254497 **Genuine Article#:** 246ZT **Number of References:** 57

**Title:** Titania-Sepiolite nanocomposites prepared by a surfactant templating colloidal route ( ABSTRACT AVAILABLE )

**Publication date:** 20080108

**Journal Subject Category:** CHEMISTRY, PHYSICAL; MATERIALS SCIENCE, MULTIDISCIPLINARY

**Identifiers:** KeyWord Plus(R): S-DOPED TIO<sub>2</sub>; PHOTOCATALYTIC ACTIVITY; VISIBLE-LIGHT; PILLARED CLAYS; AQUEOUS SUSPENSION; DEGRADATION; ANATASE; SILICATES; DIOXIDE; CARBON

7/8/624 (Item 295 from file: 34)

SciSearch(R) Cited Ref Sci

(c) 2010 The Thomson Corp. All rights reserved.

17224101 **Genuine Article#:** 243FG **Number of References:** 24

**Title:** The effect of process parameters on the Liquid Flame Spray generated titania nanoparticles ( ABSTRACT AVAILABLE )

**Publication date:** 20071100

**Journal Subject Category:** BIOCHEMICAL RESEARCH METHODS; BIOTECHNOLOGY & APPLIED MICROBIOLOGY; GENETICS & HEREDITY

**Descriptors:** SCIAuthor Keywords: liquid flame spray ; scale-up ; titania ; nanoparticles

**Identifiers:** KeyWord Plus(R): PARTICLES

7/8/625 (Item 296 from file: 34)

SciSearch(R) Cited Ref Sci

(c) 2010 The Thomson Corp. All rights reserved.

17187645 **Genuine Article#:** 239LA **Number of References:** 101

**Title:** Synthesis of morphology-controlled titania nanocrystals and application for dye-sensitized solar cell's ( ABSTRACT AVAILABLE )

**Publication date:** 20071100

**Journal Subject Category:** BIOTECHNOLOGY & APPLIED MICROBIOLOGY; NANOSCIENCE & NANOTECHNOLOGY; MATERIALS SCIENCE, MULTIDISCIPLINARY

**Descriptors:** SCIAuthor Keywords: titanium oxide ; nanorod ; nanowire ; dye-sensitized solar cells ; morphology-control ; electron transport

**Identifiers:** KeyWord Plus(R): TIO<sub>2</sub> NANOTUBE-ARRAYS; ELECTRON-TRANSPORT; NANOWIRE ARRAYS; THIN-FILMS; PHOTOELECTROCHEMICAL PERFORMANCE; LEPIDOCROCITE NANOSHEETS; IMPEDANCE SPECTROSCOPY; CONVERSION EFFICIENCY; ANODIC-OXIDATION; NANOPOROUS TIO<sub>2</sub>

7/8/628 (Item 299 from file: 34)

SciSearch(R) Cited Ref Sci

(c) 2010 The Thomson Corp. All rights reserved.

17163601 **Genuine Article#:** 235KB **Number of References:** 21

## Appendix A-5. Irrelevant Titles

**Title:** Hydrothermal/microwave and hydrothermal/ultrasonic synthesis of nanocrystalline titania, zirconia, and hafnia ( ABSTRACT AVAILABLE )

**Publication date:** 20071100

**Journal Subject Category:** CHEMISTRY, INORGANIC & NUCLEAR

**Identifiers:** KeyWord Plus(R): POWDERS

7/8/629 (Item 300 from file: 34)

SciSearch(R) Cited Ref Sci

(c) 2010 The Thomson Corp. All rights reserved.

17150477 **Genuine Article#:** 233YS **Number of References:** 28

**Title:** Photocatalytic degradation of methyl orange in aqueous suspension of mesoporous titania nanoparticles

( ABSTRACT AVAILABLE )

**Publication date:** 20071100

**Journal Subject Category:** ENVIRONMENTAL SCIENCES

**Descriptors:** SCIAuthor Keywords: mesoporous TiO<sub>2</sub> nanoparticle ; photocatalysis ; methyl orange ; degradation mechanism

**Identifiers:** KeyWord Plus(R): AZO-DYES; MASS-SPECTROMETRY; ORGANIC-COMPOUNDS; WASTE-WATER; TIO<sub>2</sub>; ANATASE; PHOTODEGRADATION; IRRADIATION; PARAMETERS; DIOXIDE

7/8/630 (Item 301 from file: 34)

SciSearch(R) Cited Ref Sci

(c) 2010 The Thomson Corp. All rights reserved.

17091500 **Genuine Article#:** 228YY **Number of References:** 46

**Title:** Nanosize titanium dioxide stimulates reactive oxygen species in brain microglia and damages neurons in vitro ( ABSTRACT AVAILABLE )

**Publication date:** 20071100

**Journal Subject Category:** ENVIRONMENTAL SCIENCES; PUBLIC, ENVIRONMENTAL & OCCUPATIONAL HEALTH

**Descriptors:** SCIAuthor Keywords: BV2 ; **environmental** nanotoxicity ; neurotoxicity ; oxidative stress ; P25 ; titanium dioxide

**Identifiers:** KeyWord Plus(R): ALVEOLAR MACROPHAGES; DOPAMINERGIC-NEURONS; ULTRAFINE PARTICLES; OXIDATIVE STRESS; EPITHELIAL-CELLS; TIO<sub>2</sub>; TOXICITY; CYTOTOXICITY; NEUROTOXICITY; PULMONARY

7/8/631 (Item 302 from file: 34)

SciSearch(R) Cited Ref Sci

(c) 2010 The Thomson Corp. All rights reserved.

17049069 **Genuine Article#:** 215IM **Number of References:** 8

**Title:** The effect of soluble sulfate concentration on the rheological behavior of nanoparticulate titania suspensions ( ABSTRACT AVAILABLE )

**Publication date:** 20070000

## Appendix A-5. Irrelevant Titles

**Journal Subject Category:** MATERIALS SCIENCE, CERAMICS

**Descriptors:** SCIAuthor Keywords: agglomeration/agglomerates ; rheology/rheometry ; titanium dioxide

7/8/632 (Item 303 from file: 34)

SciSearch(R) Cited Ref Sci

(c) 2010 The Thomson Corp. All rights reserved.

16988647 **Genuine Article#:** 216JR **Number of References:** 38

**Title:** Toxicity of titanium dioxide nanoparticles to rainbow trout (*Oncorhynchus mykiss*): Gill injury, oxidative stress, and other physiological effects ( ABSTRACT AVAILABLE )

**Publication date:** 20071030

**Journal Subject Category:** MARINE & FRESHWATER BIOLOGY; TOXICOLOGY

**Descriptors:** SCIAuthor Keywords: titanium dioxide nanoparticles ; gill ; intestine ; haematology ; Na+K+-ATPase ; TBARS ; glutathione ; rainbow trout ; copper ; zinc

**Identifiers:** KeyWord Plus(R): ULTRAFINE PARTICLES; SUBCHRONIC INHALATION; PULMONARY RESPONSES; EPITHELIAL-CELLS; SURFACE; EXPOSURE; FISH; NANOMATERIALS; INSTILLATION; INFLAMMATION

7/8/633 (Item 304 from file: 34)

SciSearch(R) Cited Ref Sci

(c) 2010 The Thomson Corp. All rights reserved.

16950179 **Genuine Article#:** 211YX **Number of References:** 37

**Title:** Preparation and properties of polyamide-titania nanocomposites ( ABSTRACT AVAILABLE )

**Publication date:** 20071000

**Journal Subject Category:** MATERIALS SCIENCE, CERAMICS

**Descriptors:** SCIAuthor Keywords: polyamide ; titania ; nanocomposites ; sol-gel process ; stress-strain data ; glass transition temperature ; morphology

**Identifiers:** KeyWord Plus(R): SOL-GEL PROCESS; SILICA HYBRID MATERIALS; COMPOSITES; COATINGS

7/8/634 (Item 305 from file: 34)

SciSearch(R) Cited Ref Sci

(c) 2010 The Thomson Corp. All rights reserved.

16949218 **Genuine Article#:** 213FK **Number of References:** 8

**Title:** Use of photoresist templates in the synthesis of highly-ordered arrays of titania nanorods ( ABSTRACT AVAILABLE )

**Publication date:** 20071200

**Journal Subject Category:** CHEMISTRY, MULTIDISCIPLINARY; NANOSCIENCE & NANOTECHNOLOGY; MATERIALS SCIENCE, MULTIDISCIPLINARY

**Descriptors:** SCIAuthor Keywords: template ; photoresist ; nanobibrils ; sol-gel process ; nanofabrication ; nanopatterns ; polymers

## Appendix A-5. Irrelevant Titles

**Identifiers:** KeyWord Plus(R): NANOMATERIALS

7/8/635 (Item 306 from file: 34)

SciSearch(R) Cited Ref Sci

(c) 2010 The Thomson Corp. All rights reserved.

16949213 **Genuine Article#:** 213FK **Number of References:** 28

**Title:** Synthesis of anatase titania-carbon nanotubes nanocomposites with enhanced photocatalytic activity through a nanocoating-hydrothermal process ( ABSTRACT AVAILABLE )

**Publication date:** 20071200

**Journal Subject Category:** CHEMISTRY, MULTIDISCIPLINARY; NANOSCIENCE & NANOTECHNOLOGY; MATERIALS SCIENCE, MULTIDISCIPLINARY

**Descriptors:** SCIAuthor Keywords: carbon nanotubes ; MWNT ; titanium dioxide ; nanocomposite ; nanocoating-hydrothermal **process** ; photocatalysis

**Identifiers:** KeyWord Plus(R): DIOXIDE NANOPARTICLES; NANOCRYSTALLINE TIO<sub>2</sub>; PHOTODEGRADATION; DEGRADATION; PHENOL; DYES

7/8/636 (Item 307 from file: 34)

SciSearch(R) Cited Ref Sci

(c) 2010 The Thomson Corp. All rights reserved.

16925650 **Genuine Article#:** 197BM **Number of References:** 33

**Title:** Synthesis of titania and titanate nanomaterials and their application in environmental analytical chemistry ( ABSTRACT AVAILABLE )

**Publication date:** 20070731

**Journal Subject Category:** CHEMISTRY, ANALYTICAL

**Descriptors:** SCIAuthor Keywords: solvothermal method ; titania ; nanotube ; photocatalyst

**Identifiers:** KeyWord Plus(R): OXIDATIVE DECOLORIZATION; PHOTOCATALYTIC ACTIVITY; VISIBLE IRRADIATION; TIO<sub>2</sub> NANOPARTICLES; HYDROGEN-PEROXIDE; DYE POLLUTANTS; WASTE-WATER; PHOTODEGRADATION; NANOTUBES; DEGRADATION

7/8/637 (Item 308 from file: 34)

SciSearch(R) Cited Ref Sci

(c) 2010 The Thomson Corp. All rights reserved.

16869107 **Genuine Article#:** 194ZD **Number of References:** 49

**Title:** Preparation of nanocrystalline titania films with different porosity by water-based chemical solution deposition ( ABSTRACT AVAILABLE )

**Publication date:** 20070900

**Journal Subject Category:** MATERIALS SCIENCE, CERAMICS

**Descriptors:** SCIAuthor Keywords: titanium dioxide ; superhydrophilic ; pore forming agent ; porous

**Identifiers:** KeyWord Plus(R): SOLUTION-GEL ROUTE; DIOXIDE THIN-FILMS; METAL-CHELATE GEL; MESOPOROUS TITANIA; BISMUTH TITANATE; PHASE-

## Appendix A-5. Irrelevant Titles

FORMATION; SOLAR-CELLS; TIO2 FILMS; PHOTOCATALYSIS; DECOMPOSITION

7/8/638 (Item 309 from file: 34)

SciSearch(R) Cited Ref Sci

(c) 2010 The Thomson Corp. All rights reserved.

16852736 **Genuine Article#:** 209QK **Number of References:** 29

**Title:** Photocatalysis of methylene blue on titanium dioxide nanoparticles synthesized by modified sol-hydrothermal process of TiCl<sub>4</sub> ( ABSTRACT AVAILABLE )

**Publication date:** 20070900

**Journal Subject Category:** CHEMISTRY, PHYSICAL

**Descriptors:** SCIAuthor Keywords: TiO<sub>2</sub> nanoparticle ; photoactivity ; methylene blue ; TiCl<sub>4</sub>

**Identifiers:** KeyWord Plus(R): TIO2 NANOPARTICLES; SUSPENDED MIXTURE; ACTIVATED CARBON; PARTICLE-SIZE; THIN-FILMS; DEGRADATION; HYDROLYSIS; OXIDATION; POWDERS; WATER

7/8/639 (Item 310 from file: 34)

SciSearch(R) Cited Ref Sci

(c) 2010 The Thomson Corp. All rights reserved.

16842039 **Genuine Article#:** 197HZ **Number of References:** 21

**Title:** Nano-cerium-element-doped titanium dioxide induces apoptosis of Bel 7402 human hepatoma cells in the presence of visible light ( ABSTRACT AVAILABLE )

**Publication date:** 20070807

**Journal Subject Category:** GASTROENTEROLOGY & HEPATOLOGY

**Descriptors:** SCIAuthor Keywords: nano titanium dioxide ; cerium ; photocatalysis ; apoptosis ; hepatoma cells

**Identifiers:** KeyWord Plus(R): TIO2 NANOPARTICLES; MALIGNANT-CELLS; PARTICLES; CYTOTOXICITY; IRRADIATION; MICRONUCLEI; INDUCTION; POWDER; DAMAGE

7/8/640 (Item 311 from file: 34)

SciSearch(R) Cited Ref Sci

(c) 2010 The Thomson Corp. All rights reserved.

16811783 **Genuine Article#:** 204JL **Number of References:** 35

**Title:** Characterization of titanium dioxide nanoparticles dispersed in organic ligand solutions by using a diffusion-ordered spectroscopy-based strategy ( ABSTRACT AVAILABLE )

**Publication date:** 20070000

**Journal Subject Category:** CHEMISTRY, MULTIDISCIPLINARY

**Descriptors:** SCIAuthor Keywords: diffusion ; ligand effects ; nanostructures ; NMR spectroscopy ; titanium dioxide

**Identifiers:** KeyWord Plus(R): FIELD GRADIENT NMR; DOSY NMR; PGSE NMR; MIXTURES; SYSTEMS; DYNAMICS; CLUSTERS; EXCHANGE; SIZE; TOOL

## Appendix A-5. Irrelevant Titles

7/8/641 (Item 312 from file: 34)

SciSearch(R) Cited Ref Sci

(c) 2010 The Thomson Corp. All rights reserved.

16788578 **Genuine Article#:** 192GD **Number of References:** 62

**Title:** Low-temperature hydrothermal synthesis of phase-pure rutile titania nanocrystals: Time temperature tuning of morphology and photocatalytic activity ( ABSTRACT AVAILABLE )

**Publication date:** 20070904

**Journal Subject Category:** MATERIALS SCIENCE, MULTIDISCIPLINARY

**Descriptors:** SCIAuthor Keywords: nanostructures ; chemical synthesis ; electron-diffraction ; X-ray diffraction ; surface properties

**Identifiers:** KeyWord Plus(R): NANOSIZED TIO2 POWDERS; NANOSTRUCTURED TITANIA; REVERSE MICELLES; THIN-FILMS; HYDROLYSIS; DIOXIDE; ANATASE; TRANSFORMATION; PARTICLES; DYES

7/8/642 (Item 313 from file: 34)

SciSearch(R) Cited Ref Sci

(c) 2010 The Thomson Corp. All rights reserved.

16784874 **Genuine Article#:** 189EB **Number of References:** 29

**Title:** Preparation of nanocrystalline porous titania films on titanium substrates by a sol-gel method with polyethylene glycol as a template ( ABSTRACT AVAILABLE )

**Publication date:** 20070800

**Journal Subject Category:** MATERIALS SCIENCE, CERAMICS

**Descriptors:** SCIAuthor Keywords: TiO2 porous film ; sol-gel ; templating ; polyethylene glycol ; titanium substrate

**Identifiers:** KeyWord Plus(R): CALCIUM-PHOSPHATE FORMATION; DIP-COATING METHOD; POLY(ETHYLENE OXIDE); PHASE-SEPARATION; TIO2 FILMS; IMPLANTS; SURFACE; SILICA; HYDROXYAPATITE; APATITE

7/8/643 (Item 314 from file: 34)

SciSearch(R) Cited Ref Sci

(c) 2010 The Thomson Corp. All rights reserved.

16782090 **Genuine Article#:** 192CI **Number of References:** 61

**Title:** Synthesis and characterization of mordenites encapsulated titania nanoparticles: Photocatalytic degradation of meta-chlorophenol ( ABSTRACT AVAILABLE )

**Publication date:** 20070801

**Journal Subject Category:** CHEMISTRY, PHYSICAL

**Descriptors:** SCIAuthor Keywords: mordenite ; synthesis ; Ti-incorporation ; characterization ; photocatalytic degradation

**Identifiers:** KeyWord Plus(R): CATALYTIC-PROPERTIES; SINGLE-CRYSTALS; METHYLENE-BLUE; DOPED TIO2; ADSORPTION; ZEOLITES; SILICALITE-1; WATER; DECOMPOSITION; REDUCTION

## Appendix A-5. Irrelevant Titles

7/8/644 (Item 315 from file: 34)

SciSearch(R) Cited Ref Sci

(c) 2010 The Thomson Corp. All rights reserved.

16778096 **Genuine Article#:** 200LX **Number of References:** 45

**Title: Rodlike silica and titania objects templated on extremely dilute aqueous dispersions of self-assembled sodium lithocholate nanotubes ( ABSTRACT AVAILABLE )**

**Publication date:** 20070915

**Journal Subject Category:** CHEMISTRY, PHYSICAL

**Descriptors:** SCIAuthor Keywords: alignment ; lithocholic acid ; nanorods ; inorganic oxide ; template ; silica ; titania ; self-assembly ; BET isotherms

**Identifiers:** KeyWord Plus(R): MESOPOROUS MOLECULAR-SIEVES; STEROID NANOTUBES; BILE-ACIDS; CHEMISTRY; NANOSTRUCTURES; SUSPENSIONS; SCATTERING; COMPLEXES; OXIDES; GELS

7/8/645 (Item 316 from file: 34)

SciSearch(R) Cited Ref Sci

(c) 2010 The Thomson Corp. All rights reserved.

16768142 **Genuine Article#:** 192VX **Number of References:** 43

**Title: Effect of titanium dioxide solubility on the formation of BaTiO<sub>3</sub> nanoparticles in supercritical water ( ABSTRACT AVAILABLE )**

**Publication date:** 20070825

**Journal Subject Category:** THERMODYNAMICS; CHEMISTRY, PHYSICAL; ENGINEERING, CHEMICAL

**Descriptors:** SCIAuthor Keywords: supercritical water ; BaTiO<sub>3</sub> nanoparticles ; solubility ; formation mechanism

**Identifiers:** KeyWord Plus(R): HYDROTHERMAL BARIUM-TITANATE; NANOCRYSTALLINE BATIO<sub>3</sub>; FINE POWDERS; TETRAGONAL BATIO<sub>3</sub>; PHASE-TRANSITION; THIN-FILMS; SIZE; TEMPERATURES; HYDROLYSIS; PRESSURES

7/8/646 (Item 317 from file: 34)

SciSearch(R) Cited Ref Sci

(c) 2010 The Thomson Corp. All rights reserved.

16758106 **Genuine Article#:** 192NL **Number of References:** 76

**Title: Au/titania composite nanoparticle arrays with controlled size and spacing by organic-inorganic nanohybridization in thin film block copolymer templates ( ABSTRACT AVAILABLE )**

**Publication date:** 20070620

**Journal Subject Category:** CHEMISTRY, MULTIDISCIPLINARY

**Descriptors:** SCIAuthor Keywords: Au/TiO<sub>2</sub> nanoparticle ; block copolymer ; sol-gel ; organic-inorganic hybrid ; photoluminescence

**Identifiers:** KeyWord Plus(R): CORE-SHELL NANOPARTICLES; GOLD

## Appendix A-5. Irrelevant Titles

NANOPARTICLES; TIO<sub>2</sub> FILMS; MESOPOROUS SILICA; TITANIUM-DIOXIDE;  
SILVER NANOPARTICLES; PHOTONIC CRYSTALS; NANOWIRE ARRAYS;  
MICELLAR FILMS; METAL-OXIDES

7/8/647 (Item 318 from file: 34)

SciSearch(R) Cited Ref Sci

(c) 2010 The Thomson Corp. All rights reserved.

16649716 **Genuine Article#:** 183EK **Number of References:** 19

**Title:** Bioelectrocatalytic application of titania nanotube array for molecule detection ( ABSTRACT AVAILABLE )

**Publication date:** 20070615

**Journal Subject Category:** BIOPHYSICS; BIOTECHNOLOGY & APPLIED MICROBIOLOGY; CHEMISTRY, ANALYTICAL ; ELECTROCHEMISTRY; NANOSCIENCE & NANOTECHNOLOGY

**Descriptors:** SCIAuthor Keywords: biosensor ; titania nanotube array ; bioelectrocatalysis ; amperometric detection

**Identifiers:** KeyWord Plus(R): GLUCOSE-OXIDASE; BIOSENSOR; ENZYME; TIO<sub>2</sub>; IMMOBILIZATION; FILMS; ADSORPTION; PROTEINS; MATRIX

7/8/648 (Item 319 from file: 34)

SciSearch(R) Cited Ref Sci

(c) 2010 The Thomson Corp. All rights reserved.

16640395 **Genuine Article#:** 181RG **Number of References:** 22

**Title:** Nanophotocatalysis using nanoparticles of titania Mineralization and finite element modelling of Solophenyl dye decolorization ( ABSTRACT AVAILABLE )

**Publication date:** 20070610

**Journal Subject Category:** CHEMISTRY, PHYSICAL

**Descriptors:** SCIAuthor Keywords: nanophotocatalysis ; finite element model ; immobilized titania nanoparticle ; mineralization ; SEEP/W and CTRN/W models

**Identifiers:** KeyWord Plus(R): TEXTILE WASTE-WATER; PHOTOCATALYTIC DEGRADATION; AQUEOUS-SOLUTION; KINETICS; REMOVAL; TIO<sub>2</sub>; EQUILIBRIUM; ADSORPTION; OXIDATION; DIOXIDE

7/8/649 (Item 320 from file: 34)

SciSearch(R) Cited Ref Sci

(c) 2010 The Thomson Corp. All rights reserved.

16639850 **Genuine Article#:** 181JG **Number of References:** 13

**Title:** Sonocatalytic degradation of methyl parathion in the presence of micron-sized and nano-sized rutile titanium dioxide catalysts and comparison of their sonocatalytic abilities ( ABSTRACT AVAILABLE )

**Publication date:** 20070702

**Journal Subject Category:** CHEMISTRY, PHYSICAL

**Descriptors:** SCIAuthor Keywords: micron-sized ; nano-sized ; rutile titanium dioxide (TiO<sub>2</sub>) ; ultrasonic irradiation ; sonocatalytic degradation ; methyl parathion

## Appendix A-5. Irrelevant Titles

**Identifiers:** KeyWord Plus(R): ULTRASOUND; REDUCTION; DYES

7/8/650 (Item 321 from file: 34)

SciSearch(R) Cited Ref Sci

(c) 2010 The Thomson Corp. All rights reserved.

16638329 **Genuine Article#:** 194QH **Number of References:** 19

**Title:** Preparation of crystalline nanosized titania by microemulsion: Evaluation of process variables ( ABSTRACT AVAILABLE )

**Publication date:** 20070731

**Journal Subject Category:** CHEMISTRY, PHYSICAL

**Descriptors:** SCIAuthor Keywords: docusate sodium salt (AOT) ; microemulsion ; methylene blue ; nanoparticles ; titanium (IV) isopropoxide (TTIP)

**Identifiers:** KeyWord Plus(R): REVERSE MICELLES; PHOTOCATALYTIC DEGRADATION; SIZE QUANTIZATION; TIO<sub>2</sub>; 2,4-DICHLOROPHENOL; SEMICONDUCTOR; DECOMPOSITION; PARTICLES; DIOXIDE; LIGHT

7/8/651 (Item 322 from file: 34)

SciSearch(R) Cited Ref Sci

(c) 2010 The Thomson Corp. All rights reserved.

16636240 **Genuine Article#:** 195CT **Number of References:** 48

**Title:** Preparation and characterization of poly(imide siloxane) (PIS)/ titania(TiO<sub>2</sub>) hybrid nanocomposites by sol-gel processes ( ABSTRACT AVAILABLE )

**Publication date:** 20070600

**Journal Subject Category:** POLYMER SCIENCE

**Descriptors:** SCIAuthor Keywords: polyimide ; poly(imide siloxane) ; titanium dioxide ; nanocomposites ; sol-gel process

**Identifiers:** KeyWord Plus(R): THIN-FILMS; MECHANICAL-PROPERTIES; OPTICAL-PROPERTIES; POLYIMIDE FILMS; MORPHOLOGY; TIO<sub>2</sub>; SURFACE; COMPOSITES; HYDROLYSIS; PRECURSORS

7/8/652 (Item 323 from file: 34)

SciSearch(R) Cited Ref Sci

(c) 2010 The Thomson Corp. All rights reserved.

16623074 **Genuine Article#:** 191RQ **Number of References:** 5

**Title:** Temperature influence on the anodic growth of self-aligned Titanium dioxide nanotube arrays ( ABSTRACT AVAILABLE )

**Publication date:** 20070900

**Journal Subject Category:** MATERIALS SCIENCE, MULTIDISCIPLINARY; PHYSICS, CONDENSED MATTER

**Descriptors:** SCIAuthor Keywords: anodic process ; self-ordered nanoporous materials ; titania nanotubes

## Appendix A-5. Irrelevant Titles

7/8/653 (Item 324 from file: 34)

SciSearch(R) Cited Ref Sci

(c) 2010 The Thomson Corp. All rights reserved.

16601475 **Genuine Article#:** 177YE **Number of References:** 43

**Title:** Behavioral and physiological changes in *Daphnia magna* when exposed to nanoparticle suspensions (titanium dioxide, nano-C-60, and C(60)HxC(70)Hx) ( ABSTRACT AVAILABLE )

**Publication date:** 20070615

**Journal Subject Category:** ENGINEERING, ENVIRONMENTAL; ENVIRONMENTAL SCIENCES

**Identifiers:** KeyWord Plus(R): ANTI-BARNACLE ACTIVITIES; WATER FLEA; CARBON NANOTUBES; OXYGEN-TRANSPORT; CYTOTOXICITY; ZOOPLANKTON; FULLERENES; AVOIDANCE; PARTICLES; CHEMISTRY

7/8/654 (Item 325 from file: 34)

SciSearch(R) Cited Ref Sci

(c) 2010 The Thomson Corp. All rights reserved.

16599293 **Genuine Article#:** 177DM **Number of References:** 24

**Title:** An integrated low temperature approach to highly photoactive nanocrystalline mesostructured titania ( ABSTRACT AVAILABLE )

**Publication date:** 20070700

**Journal Subject Category:** CHEMISTRY, PHYSICAL

**Descriptors:** SCIAuthor Keywords: nanocrystalline mesostructured TiO<sub>2</sub> ; anatase ; UV-illumination ; low temperature ; nonhydrolytic sol-gel

**Identifiers:** KeyWord Plus(R): PHOTOCATALYTIC ACTIVITY; SUPERCRITICAL CONDITIONS; TIO<sub>2</sub>; ANATASE; RUTILE; LIGHT; NANOPARTICLES; CALCINATION; IRRADIATION; PARTICLES

7/8/655 (Item 326 from file: 34)

SciSearch(R) Cited Ref Sci

(c) 2010 The Thomson Corp. All rights reserved.

16597515 **Genuine Article#:** 177HZ **Number of References:** 18

**Title:** Formation and photopatterning of nanoporous titania thin films ( ABSTRACT AVAILABLE )

**Publication date:** 20070604

**Journal Subject Category:** PHYSICS, APPLIED

**Identifiers:** KeyWord Plus(R): TIO<sub>2</sub>; ANATASE; OXIDES; COMPOSITES; SILICA

7/8/656 (Item 327 from file: 34)

SciSearch(R) Cited Ref Sci

(c) 2010 The Thomson Corp. All rights reserved.

## Appendix A-5. Irrelevant Titles

16587550 **Genuine Article#:** 181YL **Number of References:** 27

**Title:** Determination of trace rare earth elements by inductively coupled plasma optical emission spectrometry after preconcentration with immobilized nanometer titanium dioxide ( ABSTRACT AVAILABLE )

**Publication date:** 20070600

**Journal Subject Category:** CHEMISTRY, ANALYTICAL

**Descriptors:** SCIAuthor Keywords: immobilized nanometer titanium dioxide ; preconcentration ; rare earth elements ; ICP-OES

**Identifiers:** KeyWord Plus(R): HEAVY-METAL IONS; TIO2 THIN-FILM; ICP-AES; ONLINE PRECONCENTRATION; MICRO-COLUMN; WATER; ANATASE; CERIUM; SEA

7/8/657 (Item 328 from file: 34)

SciSearch(R) Cited Ref Sci

(c) 2010 The Thomson Corp. All rights reserved.

16549230 **Genuine Article#:** 172AN **Number of References:** 47

**Title:** Photoelectrochemical properties of alternating multilayer films composed of titania nanosheets and Zn porphyrin ( ABSTRACT AVAILABLE )

**Publication date:** 20070605

**Journal Subject Category:** CHEMISTRY, PHYSICAL

**Identifiers:** KeyWord Plus(R): SELF-ASSEMBLED MONOLAYERS; PHOTOCURRENT GENERATION; ELECTRON-TRANSFER; ENERGY-TRANSFER; THIN-FILMS; INTERCALATION COMPOUNDS; BORON-DIPYRRIN; SURFACE; FABRICATION; COMPLEXES

7/8/658 (Item 329 from file: 34)

SciSearch(R) Cited Ref Sci

(c) 2010 The Thomson Corp. All rights reserved.

16547976 **Genuine Article#:** 171ME **Number of References:** 63

**Title:** Chemical composition and phase identification of sodium titanate nanostructures grown from titania by hydrothermal processing ( ABSTRACT AVAILABLE )

**Publication date:** 20070400

**Journal Subject Category:** CHEMISTRY, MULTIDISCIPLINARY; PHYSICS, CONDENSED MATTER

**Descriptors:** SCIAuthor Keywords: X-ray diffraction

**Identifiers:** KeyWord Plus(R): STRUCTURAL FEATURES; AUGER PARAMETER; OXIDE NANOTUBES; TIO2 NANOTUBES; SOL-GEL; NANOWIRES; NANORODS; TEMPERATURE; HYDROGEN; BEHAVIOR

7/8/659 (Item 330 from file: 34)

SciSearch(R) Cited Ref Sci

(c) 2010 The Thomson Corp. All rights reserved.

## Appendix A-5. Irrelevant Titles

16547237 **Genuine Article#:** 170CS **Number of References:** 46

**Title:** Carbon-containing nano-titania prepared by chemical vapor deposition and its visible-light-responsive photocatalytic activity ( ABSTRACT AVAILABLE )

**Publication date:** 20070601

**Journal Subject Category:** CHEMISTRY, PHYSICAL

**Descriptors:** SCIAuthor Keywords: visible-light-responsive photocatalyst ; carbon-containing ; chemical vapor deposition

**Identifiers:** KeyWord Plus(R): SEMICONDUCTOR PHOTOCATALYSIS; TIO2 PHOTOCATALYST; NITROGEN-OXIDES; SURFACE-AREA; DIOXIDE; ANATASE; WATER; NANOPARTICLES; IRRADIATION; PHASE

7/8/660 (Item 331 from file: 34)

SciSearch(R) Cited Ref Sci

(c) 2010 The Thomson Corp. All rights reserved.

16536193 **Genuine Article#:** 171EY **Number of References:** 23

**Title:** Fabrication and fluorescence property of titanium dioxide nanotube arrays by anodizing processes ( ABSTRACT AVAILABLE )

**Publication date:** 20070500

**Journal Subject Category:** CHEMISTRY, INORGANIC & NUCLEAR

**Descriptors:** SCIAuthor Keywords: TiO2 nanotubes ; two-step anodization ; mechanism ; luminescence

**Identifiers:** KeyWord Plus(R): OXIDE NANOTUBE; ALUMINA MEMBRANES; TIO2; SEMICONDUCTOR; PHOTOCATALYSIS; NANOSTRUCTURES; OXIDATION; FILMS

7/8/661 (Item 332 from file: 34)

SciSearch(R) Cited Ref Sci

(c) 2010 The Thomson Corp. All rights reserved.

16536142 **Genuine Article#:** 171EN **Number of References:** 16

**Title:** Molecular imprinting and adsorption of bovine serum albumin on nanocrystalline titania films ( ABSTRACT AVAILABLE )

**Publication date:** 20070400

**Journal Subject Category:** CHEMISTRY, ANALYTICAL

**Descriptors:** SCIAuthor Keywords: bovine serum albumin ; molecular imprinting ; quartz crystal microbalance ; nanocrystalline titania

**Identifiers:** KeyWord Plus(R): POLYMERS; ACIDS

7/8/662 (Item 333 from file: 34)

SciSearch(R) Cited Ref Sci

(c) 2010 The Thomson Corp. All rights reserved.

16521277 **Genuine Article#:** 169IG **Number of References:** 35

**Title:** Synthesis and spectroscopic characterization of nanostructured anatase titania: A photocatalyst ( ABSTRACT AVAILABLE )

**Publication date:** 20070600

**Journal Subject Category:** MATERIALS SCIENCE, CHARACTERIZATION &

## Appendix A-5. Irrelevant Titles

### TESTING

**Descriptors:** SCIAuthor Keywords: nanocrystalline TiO<sub>2</sub> ; sol-gel ; FT-Raman ; FT-IR ; thermal analysis ; SEM

**Identifiers:** KeyWord Plus(R): NANOCRYSTALLINE ANATASE; RUTILE TITANIA; TIO<sub>2</sub> PARTICLES; THIN-FILMS; DEGRADATION; DIOXIDE; DECOMPOSITION; NANOPARTICLES; TEMPERATURE; FABRICATION

7/8/663 (Item 334 from file: 34)

SciSearch(R) Cited Ref Sci

(c) 2010 The Thomson Corp. All rights reserved.

16505533 **Genuine Article#:** 168UE **Number of References:** 22

**Title:** A nanostructured titania bioceramic implantable device capable of drug delivery to the temporal lobe of the brain ( ABSTRACT AVAILABLE )

**Publication date:** 20070601

**Journal Subject Category:** CHEMISTRY, PHYSICAL

**Descriptors:** SCIAuthor Keywords: controlled drug release ; epilepsy ; implantable devices ; valproic acid ; titania reservoirs

**Identifiers:** KeyWord Plus(R): SYSTEMS; SPECTROSCOPY; SEIZURES; FTIR

7/8/664 (Item 335 from file: 34)

SciSearch(R) Cited Ref Sci

(c) 2010 The Thomson Corp. All rights reserved.

16504475 **Genuine Article#:** 168SC **Number of References:** 94

**Title:** Bioinspired nanodevice based on the folic acid/titanium dioxide system ( ABSTRACT AVAILABLE )

**Publication date:** 20070000

**Journal Subject Category:** CHEMISTRY, MULTIDISCIPLINARY

**Descriptors:** SCIAuthor Keywords: folic acid ; molecular devices ; photochemistry ; photosensitizer ; titanium

**Identifiers:** KeyWord Plus(R): UNIVERSAL FORCE-FIELD; PHOTOSYNTHETIC REACTION-CENTER; INTERFACIAL ELECTRON-TRANSFER; PHOTOELECTROCHEMICAL PROPERTIES; TITANIUM-DIOXIDE; SOLAR-CELLS; LIGHT-DRIVEN; LOGIC GATES; RHODOPSEUDOMONAS-VIRIDIS; CONJUGATED OLIGOMERS

7/8/665 (Item 336 from file: 34)

SciSearch(R) Cited Ref Sci

(c) 2010 The Thomson Corp. All rights reserved.

16492223 **Genuine Article#:** 167DQ **Number of References:** 40

**Title:** Rapid hydrolysis of organophosphorous esters induced by nanostructured, fluorine-doped titania replicas of diatom frustules ( ABSTRACT AVAILABLE )

**Publication date:** 20070500

**Journal Subject Category:** MATERIALS SCIENCE, CERAMICS

**Identifiers:** KeyWord Plus(R): CATALYZED-HYDROLYSIS; TIO<sub>2</sub> POWDERS;

## Appendix A-5. Irrelevant Titles

TRANSFORMATIONS; PESTICIDES; CONVERSION; DIOXIDE; ALUMINA; SILICA

7/8/666 (Item 337 from file: 34)

SciSearch(R) Cited Ref Sci

(c) 2010 The Thomson Corp. All rights reserved.

16483680 **Genuine Article#:** 164WV **Number of References:** 35

**Title:** Temperature dependent photoluminescence of photocatalytically active titania nanopowders ( ABSTRACT AVAILABLE )

**Publication date:** 20070415

**Journal Subject Category:** CHEMISTRY, APPLIED; CHEMISTRY, PHYSICAL; ENGINEERING, CHEMICAL

**Descriptors:** SCIAuthor Keywords: TiO<sub>2</sub> nanoparticles ; charge recombination ; temperature dependent photoluminescence

**Identifiers:** KeyWord Plus(R): X-RAY PHOTOEMISSION; TIO<sub>2</sub>; OXIDATION; ANATASE; BEHAVIOR; HETEROJUNCTIONS; SEMICONDUCTORS; PARTICLES; INTERFACE; CATALYSTS

7/8/667 (Item 338 from file: 34)

SciSearch(R) Cited Ref Sci

(c) 2010 The Thomson Corp. All rights reserved.

16483669 **Genuine Article#:** 164WV **Number of References:** 60

**Title:** Photoactive titania nanostructured thin films: Synthesis and characteristics of ordered helical nanocoil array ( ABSTRACT AVAILABLE )

**Publication date:** 20070415

**Journal Subject Category:** CHEMISTRY, APPLIED; CHEMISTRY, PHYSICAL; ENGINEERING, CHEMICAL

**Descriptors:** SCIAuthor Keywords: titania ; nanocoil ; nanotube array ; thin film ; nanostructure

**Identifiers:** KeyWord Plus(R): OPTICAL BAND-GAP; SENSITIZED SOLAR-CELLS; OXIDE NANOTUBE ARRAYS; OF-THE-ART; PHOTOELECTROCHEMICAL CELLS; TIO<sub>2</sub> NANOTUBES; PHOTOCATALYSIS; FABRICATION; TRANSPORT; WATER

7/8/668 (Item 339 from file: 34)

SciSearch(R) Cited Ref Sci

(c) 2010 The Thomson Corp. All rights reserved.

16457883 **Genuine Article#:** 163NJ **Number of References:** 18

**Title:** Synthesis of the (hydroxypropyl)cellulose-titania hybrid nanocomposite as seen by Raman spectroscopy ( ABSTRACT AVAILABLE )

**Publication date:** 20070500

**Journal Subject Category:** POLYMER SCIENCE

**Descriptors:** SCIAuthor Keywords: (hydroxypropyl) cellulose ; nanocomposites ; synthesis ; Raman spectroscopy ; sol-gel process

**Identifiers:** KeyWord Plus(R): DERIVATIVES; ALKOXIDES; CLUSTER; ACID

## Appendix A-5. Irrelevant Titles

7/8/669 (Item 340 from file: 34)

SciSearch(R) Cited Ref Sci

(c) 2010 The Thomson Corp. All rights reserved.

16451332 **Genuine Article#:** 171SU **Number of References:** 46

**Title:** Effect of silver addition on the formation and deposition of titania nanoparticles produced by liquid flame spray ( ABSTRACT AVAILABLE )

**Publication date:** 20070800

**Journal Subject Category:** CHEMISTRY, MULTIDISCIPLINARY; NANOSCIENCE & NANOTECHNOLOGY; MATERIALS SCIENCE, MULTIDISCIPLINARY

**Descriptors:** SCIAuthor Keywords: nanoparticles ; deposition ; growth ; silver addition ; aerosols

**Identifiers:** KeyWord Plus(R): CHEMICAL-VAPOR-DEPOSITION; ONE-STEP SYNTHESIS; STRUCTURAL-PROPERTIES; CATALYTIC BEHAVIOR; SIZE DISTRIBUTION; AEROSOL SYNTHESIS; EFFECTIVE DENSITY; PARTICLES; METAL; TIO2

7/8/670 (Item 341 from file: 34)

SciSearch(R) Cited Ref Sci

(c) 2010 The Thomson Corp. All rights reserved.

16449009 **Genuine Article#:** 170VX **Number of References:** 43

**Title:** One-pot synthesis of Pt-nanoparticle-embedded mesoporous titania/silica and its remarkable thermal stability ( ABSTRACT AVAILABLE )

**Publication date:** 20070531

**Journal Subject Category:** CHEMISTRY, PHYSICAL; NANOSCIENCE & NANOTECHNOLOGY; MATERIALS SCIENCE, MULTIDISCIPLINARY

**Identifiers:** KeyWord Plus(R): THIN-FILMS; SURFACE-AREA; PHASE-TRANSFORMATION; TITANIUM-DIOXIDE; MOLECULAR-SIEVES; METAL-OXIDES; SILICA; TIO2; FRAMEWORK; DEPOSITION

7/8/671 (Item 342 from file: 34)

SciSearch(R) Cited Ref Sci

(c) 2010 The Thomson Corp. All rights reserved.

16449006 **Genuine Article#:** 170VX **Number of References:** 48

**Title:** Photocatalytic activity of sol-gel-derived nanocrystalline titania ( ABSTRACT AVAILABLE )

**Publication date:** 20070531

**Journal Subject Category:** CHEMISTRY, PHYSICAL; NANOSCIENCE & NANOTECHNOLOGY; MATERIALS SCIENCE, MULTIDISCIPLINARY

**Identifiers:** KeyWord Plus(R): PHASE-STABILITY; METHYLENE-BLUE; RUTILE TRANSFORMATION; DOPED TITANIA; PARTICLE-SIZE; TIO2; POWDERS; ANATASE; WATER; DEGRADATION

## Appendix A-5. Irrelevant Titles

7/8/672 (Item 343 from file: 34)

SciSearch(R) Cited Ref Sci

(c) 2010 The Thomson Corp. All rights reserved.

16404021 **Genuine Article#:** 158NV **Number of References:** 44

**Title:** Electrochemical lithium storage of titanate and titania nanotubes and nanorods ( ABSTRACT AVAILABLE )

**Publication date:** 20070426

**Journal Subject Category:** CHEMISTRY, PHYSICAL; NANOSCIENCE & NANOTECHNOLOGY; MATERIALS SCIENCE, MULTIDISCIPLINARY

**Identifiers:** KeyWord Plus(R): NANOCRYSTALLINE TIO<sub>2</sub> ANATASE; INTERCALATION PROPERTIES; ANNEALING TEMPERATURE; PHASE-TRANSITION; ION; ELECTRODE; PERFORMANCE; NANOWIRES; NANOSTRUCTURES; NANOPARTICLES

7/8/673 (Item 344 from file: 34)

SciSearch(R) Cited Ref Sci

(c) 2010 The Thomson Corp. All rights reserved.

16359266 **Genuine Article#:** 156IH **Number of References:** 8

**Title:** Large-scale production of titania nano-coated silica-gel beads by fluidized bed chemical vapor deposition ( ABSTRACT AVAILABLE )

**Publication date:** 20070300

**Journal Subject Category:** CHEMISTRY, MULTIDISCIPLINARY; ENGINEERING, CHEMICAL

**Descriptors:** SCIAuthor Keywords: fluidized bed chemical vapor deposition ; photocatalyst ; titania ; nano-coating

**Identifiers:** KeyWord Plus(R): PHOTOCATALYSIS; TIO<sub>2</sub>

7/8/674 (Item 345 from file: 34)

SciSearch(R) Cited Ref Sci

(c) 2010 The Thomson Corp. All rights reserved.

16351541 **Genuine Article#:** 154XN **Number of References:** 21

**Title:** Development of a self-sterilizing lancet coated with a titanium dioxide photocatalytic nano-layer for self-monitoring of blood glucose ( ABSTRACT AVAILABLE )

**Publication date:** 20070415

**Journal Subject Category:** BIOPHYSICS; BIOTECHNOLOGY & APPLIED MICROBIOLOGY; CHEMISTRY, ANALYTICAL ; ELECTROCHEMISTRY; NANOSCIENCE & NANOTECHNOLOGY

**Descriptors:** SCIAuthor Keywords: lancet ; self-sterilizing ; photocatalytic titanium dioxide nano-layer ; antibacterial properties ; lancing resistance ; SMBG

7/8/675 (Item 346 from file: 34)

## Appendix A-5. Irrelevant Titles

SciSearch(R) Cited Ref Sci

(c) 2010 The Thomson Corp. All rights reserved.

16322487 **Genuine Article#:** 151VA **Number of References:** 30

**Title:** Electrical conductivity of cluster-assembled carbon/titania nanocomposite films irradiated by highly focused vacuum ultraviolet photon beams ( ABSTRACT AVAILABLE )

**Publication date:** 20070315

**Journal Subject Category:** PHYSICS, APPLIED

**Identifiers:** KeyWord Plus(R): DIAMOND-LIKE CARBON; NANOSTRUCTURED THIN-FILMS; AMORPHOUS-CARBON; PHOTOREDUCTION; OXIDATION; DEPOSITION

7/8/676 (Item 347 from file: 34)

SciSearch(R) Cited Ref Sci

(c) 2010 The Thomson Corp. All rights reserved.

16305262 **Genuine Article#:** 151KI **Number of References:** 46

**Title:** Large aspect ratio titanate nanowire prepared by monodispersed titania submicron sphere via simple wet-chemical reactions ( ABSTRACT AVAILABLE )

**Publication date:** 20070300

**Journal Subject Category:** CHEMISTRY, INORGANIC & NUCLEAR; CHEMISTRY, PHYSICAL

**Descriptors:** SCIAuthor Keywords: nanowire ; hydrothermal ; monodisperse sphere ; nanorod

**Identifiers:** KeyWord Plus(R): TIO2 NANOTUBE ARRAYS; STRUCTURAL FEATURES; K2TI6O13 NANOWIRES; OXIDE NANOTUBES; NANOSTRUCTURES; NANOFIBERS; NANORODS; ABSORPTION; PARTICLES; STABILITY

7/8/677 (Item 348 from file: 34)

SciSearch(R) Cited Ref Sci

(c) 2010 The Thomson Corp. All rights reserved.

16281101 **Genuine Article#:** 149LQ **Number of References:** 30

**Title:** A novel method for the synthesis of titania nanotubes using sonoelectrochemical method and its application for photoelectrochemical splitting of water ( ABSTRACT AVAILABLE )

**Publication date:** 20070310

**Journal Subject Category:** CHEMISTRY, PHYSICAL; ENGINEERING, CHEMICAL

**Descriptors:** SCIAuthor Keywords: TiO2 nanotubes ; sonoelectrochemistry ; photoelectrocatalysis ; water splitting

**Identifiers:** KeyWord Plus(R): TIO2 NANOTUBES; HYDROGEN GENERATION; ANODIC-OXIDATION; SOLAR LIGHT; ARRAYS; OXIDE; ELECTROLYTES; FABRICATION; PHOTOCATALYSIS

7/8/678 (Item 349 from file: 34)

SciSearch(R) Cited Ref Sci

## Appendix A-5. Irrelevant Titles

(c) 2010 The Thomson Corp. All rights reserved.

16261283 **Genuine Article#:** 147LU **Number of References:** 53

**Title:** Low-temperature growth of a nitrogen-doped titania nanoflower film and its ability to assist photodegradation of rhodamine B in water ( ABSTRACT AVAILABLE )

**Publication date:** 20070118

**Journal Subject Category:** CHEMISTRY, PHYSICAL; NANOSCIENCE & NANOTECHNOLOGY; MATERIALS SCIENCE, MULTIDISCIPLINARY

**Identifiers:** KeyWord Plus(R): HIGH PHOTOCATALYTIC ACTIVITY; VISIBLE-LIGHT; HYDROGEN-PEROXIDE; THIN-FILMS; NANOCRYSTALLINE TIO<sub>2</sub>; AQUEOUS-SOLUTIONS; NANOTUBES; NANORODS; ANATASE; NANOSTRUCTURES

7/8/679 (Item 350 from file: 34)

SciSearch(R) Cited Ref Sci

(c) 2010 The Thomson Corp. All rights reserved.

16222812 **Genuine Article#:** 145UP **Number of References:** 0

**Title:** Nanoscale and pigment-grade titanium dioxide in rats after inhalation exposure: Evidence for atmospheric agglomeration without subsequent des-agglomeration in the lungs

**Publication date:** 20070000

**Journal Subject Category:** PATHOLOGY; TOXICOLOGY

7/8/680 (Item 351 from file: 34)

SciSearch(R) Cited Ref Sci

(c) 2010 The Thomson Corp. All rights reserved.

16216227 **Genuine Article#:** 143KM **Number of References:** 11

**Title:** Nucleation and growth of titania nanoparticles prepared by pulsed injection metal organic chemical vapor deposition from a single molecular precursor ( ABSTRACT AVAILABLE )

**Publication date:** 20070300

**Journal Subject Category:** MATERIALS SCIENCE, CERAMICS

**Identifiers:** KeyWord Plus(R): RUTILE TRANSFORMATION; THIN-FILMS; ANATASE; MOCVD; TIO<sub>2</sub>

7/8/681 (Item 352 from file: 34)

SciSearch(R) Cited Ref Sci

(c) 2010 The Thomson Corp. All rights reserved.

16210647 **Genuine Article#:** 142LN **Number of References:** 41

**Title:** Inhalation exposure study of titanium dioxide nanoparticles with a primary particle size of 2 to 5 nm ( ABSTRACT AVAILABLE )

**Publication date:** 20070300

**Journal Subject Category:** ENVIRONMENTAL SCIENCES; PUBLIC, ENVIRONMENTAL & OCCUPATIONAL HEALTH

**Descriptors:** SCIAuthor Keywords: aerosol ; inhalation **toxicology study** ; murine models ;

## Appendix A-5. Irrelevant Titles

nanoparticles ; nanotoxicity ; particle aggregation ; surface area ; titanium dioxide

**Identifiers:** KeyWord Plus(R): INDUCED LUNG INFLAMMATION; SURFACE-AREA; PULMONARY RESPONSES; MICE; NANOTECHNOLOGY; TOXICITY; SAFE; RATS; NANOMATERIALS; INSTILLATION

7/8/683 (Item 354 from file: 34)

SciSearch(R) Cited Ref Sci

(c) 2010 The Thomson Corp. All rights reserved.

16176044 **Genuine Article#:** 142FZ **Number of References:** 28

**Title:** Enhanced bioaccumulation of cadmium in carp in the presence of titanium dioxide nanoparticles ( ABSTRACT AVAILABLE )

**Publication date:** 20070200

**Journal Subject Category:** ENVIRONMENTAL SCIENCES

**Descriptors:** SCIAuthor Keywords: TiO<sub>2</sub> ; facilitated **transport** ; nanotoxicology ; bioaccumulation

**Identifiers:** KeyWord Plus(R): ULTRAFINE PARTICLES; ONCORHYNCHUS-MYKISS; RAINBOW-TROUT; TRANSPORT; CATALYSIS; ACCUMULATION; CONTAMINANTS; MECHANISMS; COLLOIDS; LUNG

7/8/684 (Item 355 from file: 34)

SciSearch(R) Cited Ref Sci

(c) 2010 The Thomson Corp. All rights reserved.

16134188 **Genuine Article#:** 136UD **Number of References:** 47

**Title:** Capillary condensation onto titania (TiO<sub>2</sub>) nanoparticle agglomerates ( ABSTRACT AVAILABLE )

**Publication date:** 20070227

**Journal Subject Category:** CHEMISTRY, PHYSICAL

**Identifiers:** KeyWord Plus(R): CHEMICAL-VAPOR-DEPOSITION; DIP-PEN NANOLITHOGRAPHY; ATOMIC LAYER DEPOSITION; FLOW DIFFUSION CHAMBER; HOMOGENEOUS NUCLEATION; SILICA; FILMS; DIOXIDE; SPHERES; NANOCRYSTALLINE

7/8/685 (Item 356 from file: 34)

SciSearch(R) Cited Ref Sci

(c) 2010 The Thomson Corp. All rights reserved.

16125484 **Genuine Article#:** 139YC **Number of References:** 29

**Title:** Preparation of mixed-phase titanium dioxide nanocomposites via solvothermal processing ( ABSTRACT AVAILABLE )

**Publication date:** 20070306

**Journal Subject Category:** CHEMISTRY, PHYSICAL; MATERIALS SCIENCE, MULTIDISCIPLINARY

**Identifiers:** KeyWord Plus(R): PHOTOCATALYTIC ACTIVITY; TEMPERATURE SYNTHESIS; TIO<sub>2</sub> PARTICLES; ANATASE; RUTILE; MECHANISMS;

## Appendix A-5. Irrelevant Titles

TRANSFORMATION; NANOPARTICLES; FABRICATION; SEPARATION

7/8/686 (Item 357 from file: 34)

SciSearch(R) Cited Ref Sci

(c) 2010 The Thomson Corp. All rights reserved.

16116283 **Genuine Article#:** 136GK **Number of References:** 17

**Title:** Synthesis and structural characterization of novel flower-like titanium dioxide nanostructures ( ABSTRACT AVAILABLE )

**Publication date:** 20070301

**Journal Subject Category:** PHYSICS, CONDENSED MATTER

**Descriptors:** SCIAuthor Keywords: semiconductors ; nanomaterials ; titanium dioxide

**Identifiers:** KeyWord Plus(R): ANATASE THIN-FILMS; SPRAY-PYROLYSIS; METAL-OXIDES; TIO2

7/8/687 (Item 358 from file: 34)

SciSearch(R) Cited Ref Sci

(c) 2010 The Thomson Corp. All rights reserved.

16105556 **Genuine Article#:** 131SS **Number of References:** 50

**Title:** Electronic states and photoexcitation processes of titanium dioxide nanoparticle films dip coated from aqueous Degussa P25 photocatalyst suspension ( ABSTRACT AVAILABLE )

**Publication date:** 20070115

**Journal Subject Category:** PHYSICS, APPLIED

**Identifiers:** KeyWord Plus(R): SURFACE PHOTOVOLTAGE SPECTROSCOPY; NANOCRYSTALLINE TIO2 FILMS; RESOLVED INFRARED-ABSORPTION; SENSITIZED SOLAR-CELLS; THIN-FILMS; PHOTOGENERATED ELECTRONS; TRANSFER DYNAMICS; NANOPOROUS TIO2; TRANSPORT; EFFICIENCY

7/8/688 (Item 359 from file: 34)

SciSearch(R) Cited Ref Sci

(c) 2010 The Thomson Corp. All rights reserved.

16064434 **Genuine Article#:** 132ZG **Number of References:** 21

**Title:** The instructive redox behaviour of 4-ferrocenylcatechol on nanocrystalline titanium dioxide electrodes ( ABSTRACT AVAILABLE )

**Publication date:** 20070200

**Journal Subject Category:** CHEMISTRY, APPLIED; CHEMISTRY, INORGANIC & NUCLEAR

**Descriptors:** SCIAuthor Keywords: titanium dioxide ; ferrocene ; catechol ; electrochemistry

**Identifiers:** KeyWord Plus(R): SOLAR-CELLS; SURFACE COMPLEXATION; TIO2; CATECHOL; FILMS; PHOTOSENSITIZERS; SEMICONDUCTORS; SENSITIZATION; DYES

## Appendix A-5. Irrelevant Titles

7/8/689 (Item 360 from file: 34)

SciSearch(R) Cited Ref Sci

(c) 2010 The Thomson Corp. All rights reserved.

16053299 **Genuine Article#:** 130EU **Number of References:** 30

**Title:** Anti-microbial activity of doped anatase titania coated nickel ferrite composite nanoparticles ( ABSTRACT AVAILABLE )

**Publication date:** 20070100

**Journal Subject Category:** MATERIALS SCIENCE, MULTIDISCIPLINARY;  
METALLURGY & METALLURGICAL ENGINEERING

**Descriptors:** SCIAuthor Keywords: nanoparticles ; magnetic core ; photocatalytic shell ; heat treatment ; doping effect ; anti-microbial agent

**Identifiers:** KeyWord Plus(R): REVERSE MICELLE TECHNIQUE; SEMICONDUCTOR PHOTOCATALYSIS; MAGNETIC-PROPERTIES; NIFE2O4 PARTICLES; TIO2; BACTERIA; WATER; DISINFECTION; INACTIVATION; DIOXIDE

7/8/690 (Item 361 from file: 34)

SciSearch(R) Cited Ref Sci

(c) 2010 The Thomson Corp. All rights reserved.

16034389 **Genuine Article#:** 127VO **Number of References:** 16

**Title:** Physico-chemical, photoelectrochemical and photocatalytic properties of electrodepo sited nanocrystalline titanium dioxide thin films

( ABSTRACT AVAILABLE )

**Publication date:** 20070105

**Journal Subject Category:** MATERIALS SCIENCE, MULTIDISCIPLINARY; PHYSICS,  
APPLIED

**Descriptors:** SCIAuthor Keywords: electrodeposition ; titanium dioxide ; heat treatment ; photocatalysis ; photoelectrochemical properties

**Identifiers:** KeyWord Plus(R): SOL-GEL METHOD; CATHODIC ELECTRODEPOSITION; PHOTOINDUCED HYDROPHILICITY; TIO2 FILM; ANATASE

7/8/691 (Item 362 from file: 34)

SciSearch(R) Cited Ref Sci

(c) 2010 The Thomson Corp. All rights reserved.

16034386 **Genuine Article#:** 127VO **Number of References:** 53

**Title:** Microwave dielectric behavior of nanocrystalline titanium dioxide thin films ( ABSTRACT AVAILABLE )

**Publication date:** 20070105

**Journal Subject Category:** MATERIALS SCIENCE, MULTIDISCIPLINARY; PHYSICS,  
APPLIED

**Descriptors:** SCIAuthor Keywords: sputtering ; thin films ; X-ray diffraction ; microwave dielectric properties

**Identifiers:** KeyWord Plus(R): BEAM-ASSISTED DEPOSITION; OPTICAL-PROPERTIES; TIO2 FILMS; SPUTTER-DEPOSITION; V CHARACTERISTICS; RF

## Appendix A-5. Irrelevant Titles

MAGNETRON; ION; TEMPERATURE; ANATASE; MORPHOLOGY

7/8/692 (Item 363 from file: 34)

SciSearch(R) Cited Ref Sci

(c) 2010 The Thomson Corp. All rights reserved.

16017109 **Genuine Article#:** 127LT **Number of References:** 18

**Title:** High visible-light photocatalytic activity of nitrogen-doped titania prepared from layered titania/isostearate nanocomposite ( ABSTRACT AVAILABLE )

**Publication date:** 20070215

**Journal Subject Category:** CHEMISTRY, APPLIED; CHEMISTRY, PHYSICAL; ENGINEERING, CHEMICAL

**Descriptors:** SCIAuthor Keywords: nitrogen-doped ; titanium oxide ; titania ; anatase ; photocatalysis ; visible-light photocatalyst ; sol-gel **process** ; layered material

**Identifiers:** KeyWord Plus(R): OXIDE; AMMONIA; DIOXIDE; ANATASE; TIO<sub>2</sub>; ADSORPTION; FILM

7/8/693 (Item 364 from file: 34)

SciSearch(R) Cited Ref Sci

(c) 2010 The Thomson Corp. All rights reserved.

16012496 **Genuine Article#:** 124VU **Number of References:** 30

**Title:** Enhanced accumulation of arsenate in carp in the presence of titanium dioxide nanoparticles ( ABSTRACT AVAILABLE )

**Publication date:** 20070100

**Journal Subject Category:** ENVIRONMENTAL SCIENCES; METEOROLOGY & ATMOSPHERIC SCIENCES; WATER RESOURCES

**Descriptors:** SCIAuthor Keywords: arsenic ; TiO<sub>2</sub> ; nanoparticles ; accumulation ; carp ; facilitated **transport**

**Identifiers:** KeyWord Plus(R): ULTRAFINE PARTICLES; ONCORHYNCHUS-MYKISS; RAINBOW-TROUT; ADSORPTION; TRANSPORT; GEOCHEMISTRY; REMOVAL; COLUMN; FISH

7/8/694 (Item 365 from file: 34)

SciSearch(R) Cited Ref Sci

(c) 2010 The Thomson Corp. All rights reserved.

15957662 **Genuine Article#:** 121ZI **Number of References:** 46

**Title:** Unusual crystallization behaviors of anatase nanocrystallites from a molecularly thin titania nanosheet and its stacked forms: Increase in nucleation temperature and oriented growth ( ABSTRACT AVAILABLE )

**Publication date:** 20070110

**Journal Subject Category:** CHEMISTRY, MULTIDISCIPLINARY

**Identifiers:** KeyWord Plus(R): MODULATED ELEMENTAL REACTANTS; LAYERED TITANATE; MANGANESE OXIDE; LIQUID NUCLEATION; CRYSTAL-GROWTH; FILMS; INTERCALATION; DELAMINATION; EXFOLIATION; ABSORPTION

## Appendix A-5. Irrelevant Titles

7/8/695 (Item 366 from file: 34)

SciSearch(R) Cited Ref Sci

(c) 2010 The Thomson Corp. All rights reserved.

15846219 **Genuine Article#:** 111QN **Number of References:** 29

**Title:** Preparation and characterization of titania nanotubes with mesostructured walls ( ABSTRACT AVAILABLE )

**Publication date:** 20061200

**Journal Subject Category:** MATERIALS SCIENCE, MULTIDISCIPLINARY; PHYSICS, APPLIED

**Descriptors:** SCIAuthor Keywords: titania ; nanotubes ; mesoporous ; chemical synthesis

**Identifiers:** KeyWord Plus(R): TIO2 THIN-FILMS; HYDROTHERMAL PROCESS; SILICA; TEMPLATES; CARBON; OXIDE

7/8/696 (Item 367 from file: 34)

SciSearch(R) Cited Ref Sci

(c) 2010 The Thomson Corp. All rights reserved.

15846071 **Genuine Article#:** 112FO **Number of References:** 33

**Title:** Preparation, characterization and photocatalytic performance of Nd<sup>3+</sup>-doped titania nanoparticles with mesostructure ( ABSTRACT AVAILABLE )

**Publication date:** 20070100

**Journal Subject Category:** MATERIALS SCIENCE, MULTIDISCIPLINARY; PHYSICS, APPLIED

**Descriptors:** SCIAuthor Keywords: Nd-doping ; mesostructure ; titania ; photocatalytic activity ; nanoparticles

**Identifiers:** KeyWord Plus(R): EARTH-DOPED TIO2; MESOPOROUS TIO2; DIOXIDE PHOTOCATALYSTS; ENHANCED DEGRADATION; MOLECULAR-SIEVES; ANATASE WALL; OXIDE; TRANSFORMATION; SPECTROMETRY; RESONANCE

7/8/697 (Item 368 from file: 34)

SciSearch(R) Cited Ref Sci

(c) 2010 The Thomson Corp. All rights reserved.

15838088 **Genuine Article#:** 111BJ **Number of References:** 21

**Title:** Decolorization and mineralization of textile dyes at solution bulk by heterogeneous nanophotocatalysis using immobilized nanoparticles of titanium dioxide ( ABSTRACT AVAILABLE )

**Publication date:** 20061115

**Journal Subject Category:** CHEMISTRY, PHYSICAL

**Descriptors:** SCIAuthor Keywords: TiO2 nanoparticle ; heterogeneous nanophotocatalysis ; nanostructured semiconductors ; solution bulk ; immobilized system

**Identifiers:** KeyWord Plus(R): INDUCED PHOTOCATALYTIC DEGRADATION; AQUEOUS TIO2 SUSPENSIONS; AZO DYES; REACTIVE DYES; KINETICS; WATER; PHOTODEGRADATION; POLLUTANTS; OXIDATION

## Appendix A-5. Irrelevant Titles

7/8/698 (Item 369 from file: 34)

SciSearch(R) Cited Ref Sci

(c) 2010 The Thomson Corp. All rights reserved.

15822149 **Genuine Article#:** 110FN **Number of References:** 17

**Title:** Photocatalytic degradation of the herbicide erioglaucine in the presence of nanosized titanium dioxide: Comparison and modeling of reaction kinetics (

ABSTRACT AVAILABLE )

**Publication date:** 20060000

**Journal Subject Category:** ENVIRONMENTAL SCIENCES; PUBLIC, ENVIRONMENTAL & OCCUPATIONAL HEALTH

**Descriptors:** SCIAuthor Keywords: erioglaucine ; herbicides ; photocatalysis ; advanced oxidation process ; TiO<sub>2</sub>

**Identifiers:** KeyWord Plus(R): WATER; TIO<sub>2</sub>; DYES

7/8/699 (Item 370 from file: 34)

SciSearch(R) Cited Ref Sci

(c) 2010 The Thomson Corp. All rights reserved.

15783733 **Genuine Article#:** 104XU **Number of References:** 28

**Title:** Unprecedented coloration of rutile titanium dioxide nanocrystalline thin films (

ABSTRACT AVAILABLE )

**Publication date:** 20070000

**Journal Subject Category:** MICROSCOPY

**Descriptors:** SCIAuthor Keywords: rutile TiO<sub>2</sub> ; XRD ; SAED ; SEM ; TEM ; UV-vis

**Identifiers:** KeyWord Plus(R): TIO<sub>2</sub>; SEMICONDUCTOR; BIOMATERIALS;

DEPOSITION; PHOTOCATALYSIS; NANOPARTICLES; CELLS

7/8/700 (Item 371 from file: 34)

SciSearch(R) Cited Ref Sci

(c) 2010 The Thomson Corp. All rights reserved.

15761750 **Genuine Article#:** 103LY **Number of References:** 26

**Title:** The removal of sodium dodecylbenzene sulfonate surfactant from water using silica/titania nanorods/nanotubes composite membrane with photocatalytic capability (

ABSTRACT AVAILABLE )

**Publication date:** 20061015

**Journal Subject Category:** CHEMISTRY, PHYSICAL; MATERIALS SCIENCE, COATINGS & FILMS; PHYSICS, APPLIED; PHYSICS, CONDENSED MATTER

**Descriptors:** SCIAuthor Keywords: silica/titania composite membrane ; photocatalysis ; membrane separation ; SDBS

**Identifiers:** KeyWord Plus(R): BINARY METAL-OXIDES; WASTE-WATER; TIO<sub>2</sub>; GEL; DEGRADATION; TIO<sub>2</sub>/SIO<sub>2</sub>; PHOTODEGRADATION; NANOTUBES; DYES

7/8/701 (Item 372 from file: 34)

SciSearch(R) Cited Ref Sci

## Appendix A-5. Irrelevant Titles

(c) 2010 The Thomson Corp. All rights reserved.

15740378 **Genuine Article#:** 100XD **Number of References:** 46

**Title:** Titanium dioxide nanoparticles induce emphysema-like lung injury in mice ( ABSTRACT AVAILABLE )

**Publication date:** 20061100

**Journal Subject Category:** BIOCHEMISTRY & MOLECULAR BIOLOGY; BIOLOGY; CELL BIOLOGY

**Descriptors:** SCIAuthor Keywords: nanotechnology ; chemokines ; placenta growth factor ; microarray ; pulmonary emphysema

**Identifiers:** KeyWord Plus(R): PLACENTAL GROWTH-FACTOR; OBSTRUCTIVE PULMONARY-DISEASE; EPITHELIAL-CELLS; GENE-EXPRESSION; INTRATRACHEAL INSTILLATION; ALVEOLAR MACROPHAGES; IN-VITRO; RAT LUNG; PARTICLES; INFLAMMATION

7/8/702 (Item 373 from file: 34)

SciSearch(R) Cited Ref Sci

(c) 2010 The Thomson Corp. All rights reserved.

15723911 **Genuine Article#:** 099KQ **Number of References:** 22

**Title:** Preparation and characterization of acrylic resin/titania hybrid nanocomposite coatings by photopolymerization and sol-gel process ( ABSTRACT AVAILABLE )

**Publication date:** 20061205

**Journal Subject Category:** POLYMER SCIENCE

**Descriptors:** SCIAuthor Keywords: hybrid nanocomposites ; radical photopolymerization ; coatings ; AFM

**Identifiers:** KeyWord Plus(R): ORGANIC-INORGANIC HYBRID; TITANIA; SILICA; FILMS

7/8/703 (Item 374 from file: 34)

SciSearch(R) Cited Ref Sci

(c) 2010 The Thomson Corp. All rights reserved.

15723712 **Genuine Article#:** 099KR **Number of References:** 26

**Title:** Preparation of titanium dioxide/polyacrylate nanocomposites by sol-gel process in reverse micelles and in situ photopolymerization ( ABSTRACT AVAILABLE )

**Publication date:** 20061215

**Journal Subject Category:** POLYMER SCIENCE

**Descriptors:** SCIAuthor Keywords: micelles ; nanocomposites ; atomic force microscopy (AFM) ; irradiation

**Identifiers:** KeyWord Plus(R): REFRACTIVE-INDEX NANOCOMPOSITES; THIN-FILMS; OPTICAL-PROPERTIES; MORPHOLOGY; PARTICLES; ALKOXIDES; PRODUCTS

7/8/704 (Item 375 from file: 34)

## Appendix A-5. Irrelevant Titles

SciSearch(R) Cited Ref Sci

(c) 2010 The Thomson Corp. All rights reserved.

15713482 **Genuine Article#:** 099ZL **Number of References:** 33

**Title: Stabilized dispersion of titania nanoparticle in UV-curable matrix through sol-gel process ( ABSTRACT AVAILABLE )**

**Publication date:** 20060900

**Journal Subject Category:** POLYMER SCIENCE

**Descriptors:** SCIAuthor Keywords: organic-inorganic hybrid ; sol-gel ; titanate ; photocurable coating ; nanocomposite

**Identifiers:** KeyWord Plus(R): ORGANIC-INORGANIC MATERIALS; INFRARED SPECTRA; HYDROLYSIS; ALKOXIDES; TIO<sub>2</sub>; PRECURSORS; PRODUCTS; DESIGN; FILMS; ACID

7/8/705 (Item 376 from file: 34)

SciSearch(R) Cited Ref Sci

(c) 2010 The Thomson Corp. All rights reserved.

15657605 **Genuine Article#:** 092HI **Number of References:** 30

**Title: Biocompatible titania microtubes formed by nanoparticles and its application in the drug delivery of valproic acid**

( ABSTRACT AVAILABLE )

**Publication date:** 20061000

**Journal Subject Category:** MATERIALS SCIENCE, MULTIDISCIPLINARY; OPTICS

**Descriptors:** SCIAuthor Keywords: microtubes ; sol-gel ; titania ; brain biocompatibility ; electronic microscopy

**Identifiers:** KeyWord Plus(R): OXIDE NANOTUBES; TIO<sub>2</sub>

7/8/706 (Item 377 from file: 34)

SciSearch(R) Cited Ref Sci

(c) 2010 The Thomson Corp. All rights reserved.

15648797 **Genuine Article#:** 092YZ **Number of References:** 21

**Title: Investigation on the sonocatalytic degradation of parathion in the presence of nanometer rutile titanium dioxide (TiO<sub>2</sub>) catalyst ( ABSTRACT AVAILABLE )**

**Publication date:** 20060921

**Journal Subject Category:** ENGINEERING, ENVIRONMENTAL; ENGINEERING, CIVIL; ENVIRONMENTAL SCIENCES

**Descriptors:** SCIAuthor Keywords: nanometer rutile titanium dioxide (TiO<sub>2</sub>) ; sonocatalytic degradation ; parathion

**Identifiers:** KeyWord Plus(R): PHOTOCATALYTIC DECOMPOSITION; ULTRASONIC IRRADIATION; AQUEOUS-SOLUTION; SUSPENSIONS; WATER

7/8/708 (Item 379 from file: 34)

SciSearch(R) Cited Ref Sci

(c) 2010 The Thomson Corp. All rights reserved.

## Appendix A-5. Irrelevant Titles

15624064 **Genuine Article#:** 089SN **Number of References:** 27

**Title:** Preparation and application of alumina- and titania- nanocrystals-dispersed thin films via sol-gel process with hot water treatment ( ABSTRACT AVAILABLE )

**Publication date:** 20061200

**Journal Subject Category:** MATERIALS SCIENCE, CERAMICS

**Descriptors:** SCIAuthor Keywords: hot water treatment ; alumina ; titania ; nanosheet

**Identifiers:** KeyWord Plus(R): NANOSHEET-PRECIPIATED COATINGS; LAYERED DOUBLE HYDROXIDES; ANATASE NANOCRYSTALS; HIGH TRANSPARENCY; FLOWERLIKE ALUMINA; POLY(ETHYLENE GLYCOL); AQUEOUS-SOLUTION; LOW-TEMPERATURES; DEPOSITION

7/8/709 (Item 380 from file: 34)

SciSearch(R) Cited Ref Sci

(c) 2010 The Thomson Corp. All rights reserved.

15610986 **Genuine Article#:** 089UU **Number of References:** 46

**Title:** Electrochemical study of photovoltaic effect of nano titanium dioxide on hemoglobin ( ABSTRACT AVAILABLE )

**Publication date:** 20060900

**Journal Subject Category:** BIOCHEMISTRY & MOLECULAR BIOLOGY; BIOLOGY; BIOPHYSICS; ELECTROCHEMISTRY

**Descriptors:** SCIAuthor Keywords: titanium dioxide ; photovoltaic effect ; hemoglobin ; electrochemistry

**Identifiers:** KeyWord Plus(R): PROTEIN SECONDARY STRUCTURE; INFRARED-SPECTRA; PHOTOCATALYTIC DEGRADATION; CYTOCHROME-C; TIO2 FILMS; OXIDE ELECTRODES; NANOPOROUS TIO2; NUCLEIC-ACIDS; ADSORPTION; HEME

7/8/710 (Item 381 from file: 34)

SciSearch(R) Cited Ref Sci

(c) 2010 The Thomson Corp. All rights reserved.

15610983 **Genuine Article#:** 089UU **Number of References:** 33

**Title:** Hemoglobin/colloidal silver nanoparticles immobilized in titania sol-gel film on glassy carbon electrode: Direct electrochemistry and electrocatalysis ( ABSTRACT AVAILABLE )

**Publication date:** 20060900

**Journal Subject Category:** BIOCHEMISTRY & MOLECULAR BIOLOGY; BIOLOGY; BIOPHYSICS; ELECTROCHEMISTRY

**Descriptors:** SCIAuthor Keywords: hemoglobin ; colloidal silver nanoparticles ; titania sol-gel ; direct electrochemistry ; electrocatalysis

**Identifiers:** KeyWord Plus(R): PYROLYTIC-GRAPHITE ELECTRODES; MODIFIED GOLD ELECTRODE; BIOMEMBRANE-LIKE FILMS; LAYER-BY-LAYER; HORSERADISH-PEROXIDASE; AMPEROMETRIC BIOSENSOR; CYTOCHROME-C; MYOGLOBIN; BIOELECTROCATALYSIS; MEMBRANE

## Appendix A-5. Irrelevant Titles

7/8/711 (Item 382 from file: 34)

SciSearch(R) Cited Ref Sci

(c) 2010 The Thomson Corp. All rights reserved.

15604167 **Genuine Article#:** 087PD **Number of References:** 15

**Title:** Nano-crystalline titanium dioxide formed by reactive plasma synthesis ( ABSTRACT AVAILABLE )

**Publication date:** 20060907

**Journal Subject Category:** MATERIALS SCIENCE, MULTIDISCIPLINARY; PHYSICS, APPLIED

**Descriptors:** SCIAuthor Keywords: nano-crystalline material ; reactive plasma synthesis ; plasma **processing** ; photocatalysis ; titanium oxide

**Identifiers:** KeyWord Plus(R): THERMAL PLASMA; ALUMINA; OXIDATION

7/8/712 (Item 383 from file: 34)

SciSearch(R) Cited Ref Sci

(c) 2010 The Thomson Corp. All rights reserved.

15596745 **Genuine Article#:** 085VW **Number of References:** 17

**Title:** Modification of titanium surface species of titania by attachment of silica nanoparticles ( ABSTRACT AVAILABLE )

**Publication date:** 20060825

**Journal Subject Category:** MATERIALS SCIENCE, MULTIDISCIPLINARY; PHYSICS, CONDENSED MATTER

**Descriptors:** SCIAuthor Keywords: silica nanoparticles-attached titania ; titanium surface species ; surface modification

**Identifiers:** KeyWord Plus(R): AQUEOUS HYDROGEN-PEROXIDE; PHASE-BOUNDARY CATALYSIS; ALKENE EPOXIDATION; TIO<sub>2</sub>; PARTICLES; OXIDE

7/8/713 (Item 384 from file: 34)

SciSearch(R) Cited Ref Sci

(c) 2010 The Thomson Corp. All rights reserved.

15595249 **Genuine Article#:** 086GI **Number of References:** 36

**Title:** Surface modification of titania nanoparticles using ultrathin ceramic films ( ABSTRACT AVAILABLE )

**Publication date:** 20061000

**Journal Subject Category:** MATERIALS SCIENCE, CERAMICS

**Identifiers:** KeyWord Plus(R): CHEMICAL-VAPOR-DEPOSITION; ATOMIC LAYER DEPOSITION; BINARY REACTION SEQUENCE; FLUIDIZED-BED REACTOR; BN PARTICLES; THIN-FILMS; GROWTH; AL<sub>2</sub>O<sub>3</sub>; CHEMISTRY; COATINGS

7/8/714 (Item 385 from file: 34)

SciSearch(R) Cited Ref Sci

(c) 2010 The Thomson Corp. All rights reserved.

15588269 **Genuine Article#:** 086UT **Number of References:** 8

## Appendix A-5. Irrelevant Titles

**Title: Synthesis and characterization of titania nanoparticles by microemulsion process**  
( ABSTRACT AVAILABLE )

**Publication date:** 20060900

**Journal Subject Category:** CHEMISTRY, MULTIDISCIPLINARY

7/8/715 (Item 386 from file: 34)

SciSearch(R) Cited Ref Sci

(c) 2010 The Thomson Corp. All rights reserved.

15585204 **Genuine Article#:** 087ES **Number of References:** 35

**Title: Photocatalytic treatment of RDX wastewater with nano-sized titanium dioxide** ( ABSTRACT AVAILABLE )

**Publication date:** 20060900

**Journal Subject Category:** ENVIRONMENTAL SCIENCES

**Descriptors:** SCIAuthor Keywords: degradation ; photocatalysis ; RDX ; titanium dioxide ; wastewater

**Identifiers:** KeyWord Plus(R): HEXAHYDRO-1,3,5-TRINITRO-1,3,5-TRIAZINE RDX; FENTONS REAGENT; EXPLOSIVES RDX; BIODEGRADATION; OXIDATION; SOIL; TOXICITY; KINETICS; SLURRY; HMX

7/8/716 (Item 387 from file: 34)

SciSearch(R) Cited Ref Sci

(c) 2010 The Thomson Corp. All rights reserved.

15584698 **Genuine Article#:** 087CZ **Number of References:** 24

**Title: Electrochemiluminescent determination of chlorphenamine maleate based on Ru(bpy)(2+)(3) immobilized in a nano-titania/nafion membrane** ( ABSTRACT AVAILABLE )

**Publication date:** 20060900

**Journal Subject Category:** CHEMISTRY, ANALYTICAL; ELECTROCHEMISTRY

**Descriptors:** SCIAuthor Keywords: electrochemiluminescence ; Ru(bpy)(2+)(3) ; modified electrode ; immobilized ; chlorpheniramine maleate

**Identifiers:** KeyWord Plus(R): COMPOSITE THIN-FILMS; ELECTROGENERATED CHEMILUMINESCENT DETERMINATION; LIQUID-CHROMATOGRAPHIC DETERMINATION; TRIS(2,2'-BIPYRIDINE)RUTHENIUM(II); TRIS(2,2'-BIPYRIDYL)RUTHENIUM(III); CHLORPHENIRAMINE; ALKALOIDS; CODEINE

7/8/717 (Item 388 from file: 34)

SciSearch(R) Cited Ref Sci

(c) 2010 The Thomson Corp. All rights reserved.

15579826 **Genuine Article#:** 088DQ **Number of References:** 11

**Title: Surface functionalisation of polymer nanofibres by sputter coating of titanium dioxide** ( ABSTRACT AVAILABLE )

**Publication date:** 20060915

**Journal Subject Category:** CHEMISTRY, PHYSICAL; MATERIALS SCIENCE, COATINGS & FILMS; PHYSICS, APPLIED; PHYSICS, CONDENSED MATTER

## Appendix A-5. Irrelevant Titles

**Descriptors:** SCIAuthor Keywords: nanofibres ; TiO<sub>2</sub> ; sputtering ; AFM ; XRD ; XPS ; ESEM

**Identifiers:** KeyWord Plus(R): HYDROPHILICITY; FILMS

7/8/718 (Item 389 from file: 34)

SciSearch(R) Cited Ref Sci

(c) 2010 The Thomson Corp. All rights reserved.

15508036 **Genuine Article#:** 081FF **Number of References:** 22

**Title:** Preparation of mesoporous titania nanocrystals using alkylamine surfactant templates ( ABSTRACT AVAILABLE )

**Publication date:** 20060000

**Journal Subject Category:** MATERIALS SCIENCE, CERAMICS

**Descriptors:** SCIAuthor Keywords: calcination ; sol-gel processes ; TiO<sub>2</sub> ; surfactant-assisted templating method

**Identifiers:** KeyWord Plus(R): SYSTEMS; TIO<sub>2</sub>; AREA

7/8/719 (Item 390 from file: 34)

SciSearch(R) Cited Ref Sci

(c) 2010 The Thomson Corp. All rights reserved.

15491250 **Genuine Article#:** 077QO **Number of References:** 28

**Title:** 4,4'-Bismaleimidodiphenyl methane modified novolak resin/titania nanocomposites: Preparation and properties ( ABSTRACT AVAILABLE )

**Publication date:** 20061005

**Journal Subject Category:** POLYMER SCIENCE

**Descriptors:** SCIAuthor Keywords: nanocomposites ; resins ; thermal properties

**Identifiers:** KeyWord Plus(R): SOL-GEL PROCESS; HYBRID MATERIALS; INORGANIC MATERIALS; SILICA; POLYMERS; METHACRYLATE); COMPOSITES; ALKOXIDES; GLASSES; FILMS

7/8/720 (Item 391 from file: 34)

SciSearch(R) Cited Ref Sci

(c) 2010 The Thomson Corp. All rights reserved.

15477792 **Genuine Article#:** 075VO **Number of References:** 39

**Title:** A novel approach to the hydrothermal synthesis of anatase Titania nanoparticles and the photocatalytic degradation of rhodamine B ( ABSTRACT AVAILABLE )

**Publication date:** 20060000

**Journal Subject Category:** CHEMISTRY, MULTIDISCIPLINARY; ENGINEERING, CHEMICAL

**Identifiers:** KeyWord Plus(R): AQUEOUS TIO<sub>2</sub> DISPERSIONS; PHOTOASSISTED DEGRADATION; NANOCRYSTALLINE ANATASE; MESOPOROUS TITANIA; CATALYTIC-ACTIVITY; LIGHT IRRADIATION; METHYLENE-BLUE; DYE POLLUTANTS; VISIBLE-LIGHT; AZO-DYE

## Appendix A-5. Irrelevant Titles

7/8/721 (Item 392 from file: 34)

SciSearch(R) Cited Ref Sci

(c) 2010 The Thomson Corp. All rights reserved.

15468093 **Genuine Article#:** 074NB **Number of References:** 29

**Title:** Influence of N-doping on the structure and electronic properties of titania nanoparticle photocatalysts ( ABSTRACT AVAILABLE )

**Publication date:** 20060824

**Journal Subject Category:** CHEMISTRY, PHYSICAL

**Identifiers:** KeyWord Plus(R): X-RAY-ABSORPTION; CONTAINING TIO2 PHOTOCATALYSTS; EDGE STRUCTURE; K EDGES; OXIDES; SPECTROSCOPY; SPECTRA; XANES; ANATASE; COORDINATION

7/8/722 (Item 393 from file: 34)

SciSearch(R) Cited Ref Sci

(c) 2010 The Thomson Corp. All rights reserved.

15445981 **Genuine Article#:** 072KH **Number of References:** 48

**Title:** Photocatalytic activity of epoxide sol-gel derived titania transformed into nanocrystalline aerogel powders by supercritical drying ( ABSTRACT AVAILABLE )

**Publication date:** 20060801

**Journal Subject Category:** CHEMISTRY, PHYSICAL

**Descriptors:** SCIAuthor Keywords: aerogel TiO2 ; nanocrystalline ; epoxide ; sol-gel ; supercritical drying ; photocatalysis ; phenol degradation

**Identifiers:** KeyWord Plus(R): HETEROGENEOUS PHOTOCATALYSIS; SURFACE PHOTOCHEMISTRY; MESOPOROUS ANATASE; ALUMINA AEROGELS; TIO2 AEROGELS; SEMICONDUCTOR; DIOXIDE; CRYSTALLINE; DEGRADATION; PRECURSORS

7/8/723 (Item 394 from file: 34)

SciSearch(R) Cited Ref Sci

(c) 2010 The Thomson Corp. All rights reserved.

15439648 **Genuine Article#:** 071RQ **Number of References:** 24

**Title:** The template preparation and characterization of three new shapes of titania nanometer-array systems ( ABSTRACT AVAILABLE )

**Publication date:** 20060600

**Journal Subject Category:** MULTIDISCIPLINARY SCIENCES

**Descriptors:** SCIAuthor Keywords: titania ; template preparation ; nanometer-arrays ; solelectrophoresis ; sol-gel

**Identifiers:** KeyWord Plus(R): NANOWIRE ARRAYS; TIO2; SILICON

7/8/724 (Item 395 from file: 34)

## Appendix A-5. Irrelevant Titles

SciSearch(R) Cited Ref Sci

(c) 2010 The Thomson Corp. All rights reserved.

15435694 **Genuine Article#:** 072CG **Number of References:** 26

**Title:** Sonocatalytic degradation of methyl parathion in the presence of nanometer and ordinary anatase titanium dioxide catalysts and comparison of their sonocatalytic abilities ( ABSTRACT AVAILABLE )

**Publication date:** 20060900

**Journal Subject Category:** ACOUSTICS; CHEMISTRY, MULTIDISCIPLINARY

**Descriptors:** SCIAuthor Keywords: anatase titanium dioxide (TiO<sub>2</sub>) ; ultrasonic irradiation ; sonocatalytic degradation ; methyl parathion

**Identifiers:** KeyWord Plus(R): HETEROGENEOUS PHOTOCATALYTIC DECOMPOSITION; AQUEOUS-SOLUTIONS; SONOCHEMICAL DEGRADATION; ULTRASONIC IRRADIATION; TIO<sub>2</sub> POWDER; PHENOL; SUSPENSIONS; OXIDATION; WATER; PHOTODEGRADATION

7/8/725 (Item 396 from file: 34)

SciSearch(R) Cited Ref Sci

(c) 2010 The Thomson Corp. All rights reserved.

15395955 **Genuine Article#:** 066TQ **Number of References:** 22

**Title:** Daphnia magna mortality when exposed to titanium dioxide and fullerene (C-60) nanoparticles ( ABSTRACT AVAILABLE )

**Publication date:** 20060400

**Journal Subject Category:** ENVIRONMENTAL SCIENCES; TOXICOLOGY

**Descriptors:** SCIAuthor Keywords: fullerenes ; titanium dioxide ; nanoparticles ; Daphnia magna ; mortality

**Identifiers:** KeyWord Plus(R): CARBON NANOTUBES; PARTICLES; TOXICITY; BRAIN

7/8/726 (Item 397 from file: 34)

SciSearch(R) Cited Ref Sci

(c) 2010 The Thomson Corp. All rights reserved.

15384794 **Genuine Article#:** 065EI **Number of References:** 38

**Title:** Photoinduced charge separation in titania nanotubes ( ABSTRACT AVAILABLE )

**Publication date:** 20060727

**Journal Subject Category:** CHEMISTRY, PHYSICAL

**Identifiers:** KeyWord Plus(R): DIFFUSE-REFLECTANCE SPECTROSCOPY; ONE-ELECTRON OXIDATION; CHLORINATED METHANES; CARRIER DYNAMICS; FLASH-PHOTOLYSIS; HOLE SCAVENGERS; TIO<sub>2</sub> PARTICLES; DIOXIDE FILMS; SOLAR-CELLS; SURFACE

7/8/728 (Item 399 from file: 34)

SciSearch(R) Cited Ref Sci

(c) 2010 The Thomson Corp. All rights reserved.

## Appendix A-5. Irrelevant Titles

15360251 **Genuine Article#:** 064XX **Number of References:** 19

**Title:** Electrochemical investigation on the catalytic ability of tyrosinase with the effect of nano titanium dioxide ( ABSTRACT AVAILABLE )

**Publication date:** 20060700

**Journal Subject Category:** ELECTROCHEMISTRY

**Descriptors:** SCIAuthor Keywords: chronoamperometry ; tyrosinase ; nano titanium dioxide ; photovoltaic effect

**Identifiers:** KeyWord Plus(R): PROTEIN SECONDARY STRUCTURE; HYDROGEN-PEROXIDE; BIOSENSOR; ELECTRODE; PHENOLS; SPECTRA

7/8/729 (Item 400 from file: 34)

SciSearch(R) Cited Ref Sci

(c) 2010 The Thomson Corp. All rights reserved.

15336200 **Genuine Article#:** 06100 **Number of References:** 29

**Title:** Photocatalytic degradation of trace-level of Microcystin-LR by nano -film of titanium dioxide ( ABSTRACT AVAILABLE )

**Publication date:** 20060500

**Journal Subject Category:** MULTIDISCIPLINARY SCIENCES

**Descriptors:** SCIAuthor Keywords: photocatalytic ; microcystin-LR ; TiO<sub>2</sub> ; degradation ; trace-level

**Identifiers:** KeyWord Plus(R): TIO<sub>2</sub>; CYANOBACTERIA; DESTRUCTION; TOXINS; WATER; PHOTODEGRADATION; OXIDATION; ACID

7/8/730 (Item 401 from file: 34)

SciSearch(R) Cited Ref Sci

(c) 2010 The Thomson Corp. All rights reserved.

15326273 **Genuine Article#:** 059PH **Number of References:** 30

**Title:** Preparation of inorganic-organic hybrid titania sol-gel nanocomposite films, and their dielectric properties ( ABSTRACT AVAILABLE )

**Publication date:** 20060600

**Journal Subject Category:** MATERIALS SCIENCE, MULTIDISCIPLINARY; PHYSICS, APPLIED; PHYSICS, CONDENSED MATTER

**Identifiers:** KeyWord Plus(R): RUTILE TIO<sub>2</sub>; HYBRID; COMPOSITES; ANATASE; POWDERS

7/8/731 (Item 402 from file: 34)

SciSearch(R) Cited Ref Sci

(c) 2010 The Thomson Corp. All rights reserved.

15314559 **Genuine Article#:** 057YX **Number of References:** 27

**Title:** Electrophoretic deposition of titanate nanotubes from commercial titania nanoparticles: Application to dye-sensitized solar cells ( ABSTRACT AVAILABLE )

**Publication date:** 20060600

**Journal Subject Category:** ELECTROCHEMISTRY

**Descriptors:** SCIAuthor Keywords: titanate nanotubes ; FTO glass ; electrophoretic

## Appendix A-5. Irrelevant Titles

deposition ; dye-sensitized solar cells

**Identifiers:** KeyWord Plus(R): ZINC-OXIDE FILMS; CATHODIC ELECTRODEPOSITION; COPPER(I) OXIDE; CONVERSION; COATINGS

7/8/733 (Item 404 from file: 34)

SciSearch(R) Cited Ref Sci

(c) 2010 The Thomson Corp. All rights reserved.

15283503 **Genuine Article#:** 055IB **Number of References:** 10

**Title:** Regularity control of porous anodic alumina and photodegradation activity of highly ordered titania nanostructures ( ABSTRACT AVAILABLE )

**Publication date:** 20060600

**Journal Subject Category:** METALLURGY & METALLURGICAL ENGINEERING

**Descriptors:** SCIAuthor Keywords: PAA template ; titania structures ; theoretical model ; photocatalytic activity

**Identifiers:** KeyWord Plus(R): NANOWIRE; ARRAYS

7/8/734 (Item 405 from file: 34)

SciSearch(R) Cited Ref Sci

(c) 2010 The Thomson Corp. All rights reserved.

15283127 **Genuine Article#:** 052QS **Number of References:** 21

**Title:** Synthesis and photoluminescence of poly(3-hexylthiophene)/titania nanostructured hybrids ( ABSTRACT AVAILABLE )

**Publication date:** 20060726

**Journal Subject Category:** MATERIALS SCIENCE, MULTIDISCIPLINARY; MATERIALS SCIENCE, COATINGS & FILMS; PHYSICS, APPLIED; PHYSICS, CONDENSED MATTER

**Descriptors:** SCIAuthor Keywords: polymer/titania hybrids ; silane-containing polythiophene ; conductive polymers ; photoluminescence

**Identifiers:** KeyWord Plus(R): DONOR-ACCEPTOR HETEROJUNCTIONS; SOLAR-CELLS; PHOTOVOLTAIC CELLS; CONJUGATED POLYMER; CHARGE SEPARATION; COMPOSITES; NANOPARTICLES; FABRICATION; CONVERSION; TIO<sub>2</sub>

7/8/735 (Item 406 from file: 34)

SciSearch(R) Cited Ref Sci

(c) 2010 The Thomson Corp. All rights reserved.

15272465 **Genuine Article#:** 053TV **Number of References:** 24

**Title:** Synthesis, characterization and sintering of nanocrystalline titania powders produced by chemical vapour synthesis ( ABSTRACT AVAILABLE )

**Publication date:** 20060521

**Journal Subject Category:** PHYSICS, APPLIED

**Identifiers:** KeyWord Plus(R): PHASE-TRANSFORMATION; TIO<sub>2</sub>; TEMPERATURE;

## Appendix A-5. Irrelevant Titles

PARTICLES; CONSOLIDATION; DENSIFICATION; PRESSURE; GROWTH; SIZE; SPS

7/8/736 (Item 407 from file: 34)

SciSearch(R) Cited Ref Sci

(c) 2010 The Thomson Corp. All rights reserved.

15200222 **Genuine Article#:** 048GD **Number of References:** 60

**Title: Effects of boron doping on photocatalytic activity and microstructure of titanium dioxide nanoparticles ( ABSTRACT AVAILABLE )**

**Publication date:**

20060607

**Journal Subject Category:** ENGINEERING, CHEMICAL

**Identifiers:** KeyWord Plus(R): CODOPED TIO2 PHOTOCATALYSTS; VISIBLE-LIGHT; PHOSPHITE DEHYDROGENASE; POLYETHYLENE-GLYCOL; SPRAY-PYROLYSIS; REGENERATION; NADH; EFFICIENT; HYDROGEN; WATER

7/8/737 (Item 408 from file: 34)

SciSearch(R) Cited Ref Sci

(c) 2010 The Thomson Corp. All rights reserved.

15145451 **Genuine Article#:** 042HK **Number of References:** 26

**Title: Biomolecular modification of hierarchical cellulose fibers through titania nanocoating**

**Publication date:** 20060000

**Journal Subject Category:** CHEMISTRY, MULTIDISCIPLINARY

**Descriptors:** SCIAuthor Keywords: cellulose fibers ; fluorescence ; nanostructures ; proteins ; sol-gel processes

**Identifiers:** KeyWord Plus(R): SOL-GEL PROCESS; CARBON NANOTUBES; PROTEIN; REPLICATION; ADSORPTION; SURFACE; FILMS; TRANSPORTERS; NANOPARTICLE; PRECISION

7/8/738 (Item 409 from file: 34)

SciSearch(R) Cited Ref Sci

(c) 2010 The Thomson Corp. All rights reserved.

15099982 **Genuine Article#:** 035QK **Number of References:** 29

**Title: Surface modification on nanoscale titanium dioxide by radiation: Preparation and characterization ( ABSTRACT AVAILABLE )**

**Publication date:** 20060605

**Journal Subject Category:** POLYMER SCIENCE

**Descriptors:** SCIAuthor Keywords: nanoscale titanium dioxide ; MMA ; radiation induced ; graft polymerization ; surface modification ; nanocomposites

**Identifiers:** KeyWord Plus(R): ION-BEAM MODIFICATION; VINYL MONOMERS; GRAFT-POLYMERIZATION; MAGNESIUM-OXIDE; TIO2 FILM; IN-VITRO; IMMOBILIZATION; POLYMERS; PHOTOPOLYMERIZATION; FORCES

## Appendix A-5. Irrelevant Titles

7/8/739 (Item 410 from file: 34)

SciSearch(R) Cited Ref Sci

(c) 2010 The Thomson Corp. All rights reserved.

15086384 **Genuine Article#:** 034SZ **Number of References:** 20

**Title:** **Organo-silica-titania nanocomposite elaborated by sol-gel processing with tunable optical properties** ( ABSTRACT AVAILABLE )

**Publication date:** 20060415

**Journal Subject Category:** MATERIALS SCIENCE, MULTIDISCIPLINARY; PHYSICS, CONDENSED MATTER

**Descriptors:** SCIAuthor Keywords: refractive index ; transmission ; organic-inorganic hybrid materials ; sol-gel ; photopolymerisation ; chelating agent

**Identifiers:** KeyWord Plus(R): INORGANIC NANOCOMPOSITES; HYBRID; FILMS; POLYMERIZATION; COATINGS; NETWORKS

7/8/740 (Item 411 from file: 34)

SciSearch(R) Cited Ref Sci

(c) 2010 The Thomson Corp. All rights reserved.

15075367 **Genuine Article#:** 034WP **Number of References:** 52

**Title:** **Processing of macroporous titania thin films: From multiscale functional porosity to nanocrystalline macroporous TiO<sub>2</sub>** ( ABSTRACT AVAILABLE )

**Publication date:** 20060418

**Journal Subject Category:** CHEMISTRY, PHYSICAL; MATERIALS SCIENCE, MULTIDISCIPLINARY

**Identifiers:** KeyWord Plus(R): DIP-COATING METHOD; PERIODIC MESOPOROUS SILICA; POLY(ETHYLENE GLYCOL); GEL; SYSTEM; MORPHOLOGY; NANOCOMPOSITES; DESIGN; OXIDES; TEXTURATION

7/8/741 (Item 412 from file: 34)

SciSearch(R) Cited Ref Sci

(c) 2010 The Thomson Corp. All rights reserved.

15069516 **Genuine Article#:** 034BW **Number of References:** 11

**Title:** **Study on ageing resistance of polypropylene/nano-scale rutile titanium dioxide/POE polyolefin elastomer composites** ( ABSTRACT AVAILABLE )

**Publication date:** 20060400

**Journal Subject Category:** POLYMER SCIENCE

**Descriptors:** SCIAuthor Keywords: nano-TiO<sub>2</sub> ; bulk-TiO<sub>2</sub> ; polypropylene ; ultraviolet-visible light properties ; impact properties ; ageing resistance

**Identifiers:** KeyWord Plus(R): ANATASE

7/8/742 (Item 413 from file: 34)

SciSearch(R) Cited Ref Sci

(c) 2010 The Thomson Corp. All rights reserved.

15037990 **Genuine Article#:** 030QQ **Number of References:** 20

## Appendix A-5. Irrelevant Titles

**Title:** Synthesis and characterisation of nanotubular titanates and titania ( ABSTRACT AVAILABLE )

**Publication date:** 20060000

**Journal Subject Category:** MATERIALS SCIENCE, CERAMICS

**Descriptors:** SCIAuthor Keywords: nanotubes ; TiO<sub>2</sub> ; titanates

**Identifiers:** KeyWord Plus(R): OXIDE NANOTUBES; TIO2 NANOTUBES

7/8/743 (Item 414 from file: 34)

SciSearch(R) Cited Ref Sci

(c) 2010 The Thomson Corp. All rights reserved.

15018174 **Genuine Article#:** 028FU **Number of References:** 24

**Title:** Stabilized dispersions of titania nanoparticles via a sol-gel process and applications in UV-curable hybrid systems ( ABSTRACT AVAILABLE )

**Publication date:** 20060400

**Journal Subject Category:** POLYMER SCIENCE

**Descriptors:** SCIAuthor Keywords: nanocomposite ; organic-inorganic hybrid ; photopolymerization ; sol-gel ; titanate

**Identifiers:** KeyWord Plus(R): FILMS; TIO<sub>2</sub>

7/8/744 (Item 415 from file: 34)

SciSearch(R) Cited Ref Sci

(c) 2010 The Thomson Corp. All rights reserved.

15017012 **Genuine Article#:** 028DO **Number of References:** 22

**Title:** Intensity-dependent relaxation of photoconductivity in nanocrystalline titania thin films ( ABSTRACT AVAILABLE )

**Publication date:** 20060300

**Journal Subject Category:** PHYSICS, CONDENSED MATTER

**Identifiers:** KeyWord Plus(R): TRANSIENT PHOTOCONDUCTIVITY; NANOSTRUCTURED TIO<sub>2</sub>; CHARGE-CARRIERS; SPRAY-PYROLYSIS; ANATASE TIO<sub>2</sub>; TRANSPORT; DIOXIDE; ELECTRONS; MOBILITY; CELLS

7/8/745 (Item 416 from file: 34)

SciSearch(R) Cited Ref Sci

(c) 2010 The Thomson Corp. All rights reserved.

15010377 **Genuine Article#:** 028PW **Number of References:** 53

**Title:** Preparation, phase transformation and photocatalytic activities of cerium-doped mesoporous titania nanoparticles ( ABSTRACT AVAILABLE )

**Publication date:** 20060400

**Journal Subject Category:** CHEMISTRY, INORGANIC & NUCLEAR; CHEMISTRY, PHYSICAL

**Descriptors:** SCIAuthor Keywords: cerium doped ; mesoporous materials ; titania ; nanoparticles ; anatase

**Identifiers:** KeyWord Plus(R): TIO<sub>2</sub> PARTICLES; MOLECULAR-SIEVES; SURFACE-AREA; ANATASE WALL; THIN-FILMS; DIOXIDE; OXIDE; OXIDATION;

## Appendix A-5. Irrelevant Titles

CATALYSTS; LANTHANA

7/8/746 (Item 417 from file: 34)

SciSearch(R) Cited Ref Sci

(c) 2010 The Thomson Corp. All rights reserved.

15010112 **Genuine Article#:** 027HZ **Number of References:** 69

**Title:** Photoinduced hydrophilic conversion properties of titania nanosheets ( ABSTRACT AVAILABLE )

**Publication date:** 20060330

**Journal Subject Category:** CHEMISTRY, PHYSICAL

**Identifiers:** KeyWord Plus(R): TIO2 THIN-FILMS; SURFACE WETTABILITY CONVERSION; VISIBLE-LIGHT IRRADIATION; SUM-FREQUENCY GENERATION; X-RAY-DIFFRACTION; PHOTOCATALYTIC ACTIVITY; DOPED TIO2; SEMICONDUCTOR PHOTOCATALYSIS; H-1-NMR SPECTROSCOPY; WATER

7/8/747 (Item 418 from file: 34)

SciSearch(R) Cited Ref Sci

(c) 2010 The Thomson Corp. All rights reserved.

14937419 **Genuine Article#:** 020WS **Number of References:** 52

**Title:** Hydrothermal synthesis and characterization of nanorods of various titanates and titanium dioxide ( ABSTRACT AVAILABLE )

**Publication date:** 20060309

**Journal Subject Category:** CHEMISTRY, PHYSICAL

**Identifiers:** KeyWord Plus(R): TIO2 NANOWIRE ARRAYS; CRYSTAL-STRUCTURE; NANOTUBES; FABRICATION; TEMPERATURE; GROWTH; PHOTOLUMINESCENCE; INTERCALATION; NANOFIBERS; DEPOSITION

7/8/748 (Item 419 from file: 34)

SciSearch(R) Cited Ref Sci

(c) 2010 The Thomson Corp. All rights reserved.

14937408 **Genuine Article#:** 020WS **Number of References:** 37

**Title:** Dissolution kinetics of titanium dioxide nanoparticles : The observation of an unusual kinetic size effect ( ABSTRACT AVAILABLE )

**Publication date:** 20060309

**Journal Subject Category:** CHEMISTRY, PHYSICAL

**Identifiers:** KeyWord Plus(R): ANATASE TIO2 NANOPARTICLES; GEL-SOL METHOD; CATHODIC STRIPPING VOLTAMMETRY; AMORPHOUS TITANIA; NANOCRYSTALLINE ANATASE; ZERO CHARGE; HIGH-PURITY; POWDERS; TEMPERATURE; HYDROLYSIS

7/8/749 (Item 420 from file: 34)

SciSearch(R) Cited Ref Sci

## Appendix A-5. Irrelevant Titles

(c) 2010 The Thomson Corp. All rights reserved.

14913137 **Genuine Article#:** 003RL **Number of References:** 44

**Title:** Synthesis and growth mechanism of titanate and titania one-dimensional nanostructures self-assembled into hollow micrometer-scale spherical aggregates ( ABSTRACT AVAILABLE )

**Publication date:** 20060119

**Journal Subject Category:** CHEMISTRY, PHYSICAL

**Identifiers:** KeyWord Plus(R): ALKALI TREATMENT; TIO2 NANOTUBES; NANOWIRES; FILMS; RAMAN; NANOCRYSTALS; ORGANIZATION; FABRICATION; ABSORPTION; DANDELIONS

7/8/750 (Item 421 from file: 34)

SciSearch(R) Cited Ref Sci

(c) 2010 The Thomson Corp. All rights reserved.

14904444 **Genuine Article#:** 019HR **Number of References:** 33

**Title:** Multilayer hybrid films of titania semiconductor nanosheet and silver metal fabricated via layer-by-layer self-assembly and subsequent UV irradiation ( ABSTRACT AVAILABLE )

**Publication date:** 20060307

**Journal Subject Category:** CHEMISTRY, PHYSICAL; MATERIALS SCIENCE, MULTIDISCIPLINARY

**Identifiers:** KeyWord Plus(R): GRAPHITE LAYERS; MANGANESE OXIDE; NANOPARTICLES; INTERCALATION; SUPERLATTICES; CRYSTALLITES; DELAMINATION; EXFOLIATION; CLUSTERS; SILICA

7/8/751 (Item 422 from file: 34)

SciSearch(R) Cited Ref Sci

(c) 2010 The Thomson Corp. All rights reserved.

14891457 **Genuine Article#:** 014SH **Number of References:** 35

**Title:** Sol-gel auto-igniting synthesis and structural property of cerium-doped titanium dioxide nanosized powders ( ABSTRACT AVAILABLE )

**Publication date:** 20060000

**Journal Subject Category:** MATERIALS SCIENCE, CERAMICS

**Descriptors:** SCIAuthor Keywords: sol-gel processes ; TiO2 ; powder preparation ; optical properties

**Identifiers:** KeyWord Plus(R): LOW-TEMPERATURE SYNTHESIS; COMBUSTION SYNTHESIS; PHOTOCATALYTIC PROPERTIES; PHASE-TRANSITION; THIN-FILMS; TIO2; OXIDE; ANATASE; RUTILE; OXIDATION

7/8/752 (Item 423 from file: 34)

SciSearch(R) Cited Ref Sci

(c) 2010 The Thomson Corp. All rights reserved.

## Appendix A-5. Irrelevant Titles

14890803 **Genuine Article#:** 014UB **Number of References:** 42

**Title:** Visible light photoelectrochemical and water-photoelectrolysis properties of titania nanotube arrays ( ABSTRACT AVAILABLE )

**Publication date:** 20060220

**Journal Subject Category:** CHEMISTRY, PHYSICAL

**Descriptors:** SCIAuthor Keywords: hydrogen ; photolysis ; photoelectrolysis ; titania ; nanotube ; nanotube array

**Identifiers:** KeyWord Plus(R): SENSITIZED SOLAR-CELLS; ELECTRON-TRANSPORT; ANODIC-OXIDATION; OXIDE-FILMS; HYDROGEN; TIO<sub>2</sub>; FABRICATION; PHOTOPRODUCTION; TRANSFORMATION; RECOMBINATION

7/8/753 (Item 424 from file: 34)

SciSearch(R) Cited Ref Sci

(c) 2010 The Thomson Corp. All rights reserved.

14870010 **Genuine Article#:** 013ZK **Number of References:** 30

**Title:** Structure and thermal properties of titanium dioxide -polyacrylate nanocomposites ( ABSTRACT AVAILABLE )

**Publication date:** 20060300

**Journal Subject Category:** POLYMER SCIENCE

**Descriptors:** SCIAuthor Keywords: photopolymerization ; titanium dioxide ; nanocomposites

**Identifiers:** KeyWord Plus(R): SOL-GEL PROCESS; THIN-FILMS; ULTRAVIOLET-IRRADIATION; REVERSE MICELLES; WATER-VAPOR; HYDROLYSIS; ALKOXIDES; TEMPERATURE; MORPHOLOGY; PRODUCTS

7/8/754 (Item 425 from file: 34)

SciSearch(R) Cited Ref Sci

(c) 2010 The Thomson Corp. All rights reserved.

14862686 **Genuine Article#:** 013PI **Number of References:** 2

**Title:** Preparation and characterization of nano-scale anatase titania by electrolytic precipitate method ( ABSTRACT AVAILABLE )

**Publication date:** 20060100

**Journal Subject Category:** MATERIALS SCIENCE, CERAMICS

**Descriptors:** SCIAuthor Keywords: electrolytic method ; titania ; ultrafine powder

7/8/755 (Item 426 from file: 34)

SciSearch(R) Cited Ref Sci

(c) 2010 The Thomson Corp. All rights reserved.

14854889 **Genuine Article#:** 013IZ **Number of References:** 50

**Title:** Synthesis and photoluminescence of titania nanoparticle arrays templated by block-copolymer thin films ( ABSTRACT AVAILABLE )

**Publication date:** 20060213

## Appendix A-5. Irrelevant Titles

**Journal Subject Category:** CHEMISTRY, PHYSICAL; PHYSICS, ATOMIC, MOLECULAR & CHEMICAL

**Descriptors:** SCIAuthor Keywords: organic-inorganic hybrid ; photophysics ; polymers ; sol-gel processes ; thin films

**Identifiers:** KeyWord Plus(R): MESOPOROUS METAL-OXIDES; DIBLOCK COPOLYMER; NANOWIRE ARRAYS; TIO<sub>2</sub>; ANATASE; NANOSTRUCTURES; SEMICONDUCTOR; LITHOGRAPHY; FABRICATION; MECHANISMS

7/8/756 (Item 427 from file: 34)

SciSearch(R) Cited Ref Sci

(c) 2010 The Thomson Corp. All rights reserved.

14849162 **Genuine Article#:** 011EA **Number of References:** 98

**Title:** Synthesis of TiO<sub>2</sub>-Au composites by titania-nanorod-assisted generation of gold nanopartictes at aqueous/nonpolar interfaces ( ABSTRACT AVAILABLE )

**Publication date:** 20060300

**Journal Subject Category:** CHEMISTRY, MULTIDISCIPLINARY; NANOSCIENCE & NANOTECHNOLOGY; MATERIALS SCIENCE, MULTIDISCIPLINARY; PHYSICS, APPLIED; PHYSICS, CONDENSED MATTER

**Descriptors:** SCIAuthor Keywords: colloids ; gold ; nanocomposites ; nanorods ; titania

**Identifiers:** KeyWord Plus(R): SURFACE-PLASMON RESONANCE; COLLOIDAL SEMICONDUCTOR NANOCRYSTALS; METAL-ENHANCED FLUORESCENCE; FERMI-LEVEL EQUILIBRATION; CORE-SHELL NANOPARTICLES; LIQUID-LIQUID INTERFACE; ONE-STEP SYNTHESIS; SILVER NANOPARTICLES; SHAPE CONTROL; PALLADIUM NANOPARTICLES

7/8/757 (Item 428 from file: 34)

SciSearch(R) Cited Ref Sci

(c) 2010 The Thomson Corp. All rights reserved.

14845040 **Genuine Article#:** 010TW **Number of References:** 30

**Title:** Unprecedented ultra-high hydrogen gas sensitivity in undoped titania nanotubes ( ABSTRACT AVAILABLE )

**Publication date:** 20060128

**Journal Subject Category:** ENGINEERING, MULTIDISCIPLINARY; NANOSCIENCE & NANOTECHNOLOGY; MATERIALS SCIENCE, MULTIDISCIPLINARY; PHYSICS, APPLIED

**Identifiers:** KeyWord Plus(R): SEMICONDUCTING OXIDE NANOBELTS; CARBON-MONOXIDE; METAL-OXIDES; THIN-FILMS; SENSORS; FABRICATION; OXIDATION; DIOXIDE; ARRAYS; WATER

7/8/758 (Item 429 from file: 34)

SciSearch(R) Cited Ref Sci

(c) 2010 The Thomson Corp. All rights reserved.

14777047 **Genuine Article#:** 004PT **Number of References:** 18

**Title:** A self-cleaning, room-temperature titania-nanotube hydrogen gas sensor (

## Appendix A-5. Irrelevant Titles

ABSTRACT AVAILABLE )

**Publication date:** 20031200

**Journal Subject Category:** CHEMISTRY, ANALYTICAL; ELECTROCHEMISTRY; INSTRUMENTS & INSTRUMENTATION; PHYSICS, APPLIED

**Descriptors:** SCIAuthor Keywords: hydrogen ; sensor ; poisoning ; self-cleaning ; nanoporous

**Identifiers:** KeyWord Plus(R): TITANIUM(IV) OXIDE PARTICLES; PHOTOCATALYTIC ACTIVITY; TIO<sub>2</sub> FILMS; CLUSTERS; NANOPARTICLES; ARRAYS

7/8/759 (Item 430 from file: 34)

SciSearch(R) Cited Ref Sci

(c) 2010 The Thomson Corp. All rights reserved.

14768911 **Genuine Article#:** 004GS **Number of References:** 17

**Title:** Synthesis and characterization of porous single-crystalline titanium dioxide nanorods ( ABSTRACT AVAILABLE )

**Publication date:** 20060200

**Journal Subject Category:** MATERIALS SCIENCE, CERAMICS

**Identifiers:** KeyWord Plus(R): MESOPOROUS TIO<sub>2</sub>; TEMPERATURE; BIOMINERALIZATION; NANOCRYSTALS; PHOTONICS; GROWTH; OXIDES; CELLS

7/8/760 (Item 431 from file: 34)

SciSearch(R) Cited Ref Sci

(c) 2010 The Thomson Corp. All rights reserved.

14760498 **Genuine Article#:** 003HR **Number of References:** 14

**Title:** Factors affecting the interfacial adsorption of stabilisers on to titanium dioxide particles (flow microcalorimetry, modelling, oxidation and FTIR studies): Nano versus pigmentary grades ( ABSTRACT AVAILABLE )

**Publication date:** 20060000

**Journal Subject Category:** CHEMISTRY, APPLIED; ENGINEERING, CHEMICAL; MATERIALS SCIENCE, TEXTILES

**Descriptors:** SCIAuthor Keywords: titanium dioxide ; pigments ; nanoparticles ; degradation ; oxidation ; microcalorimetry ; interfacial adsorption

**Identifiers:** KeyWord Plus(R): MICRO-CALORIMETRY; DEGRADATION; COATINGS

7/8/761 (Item 432 from file: 34)

SciSearch(R) Cited Ref Sci

(c) 2010 The Thomson Corp. All rights reserved.

14733922 **Genuine Article#:** 001LQ **Number of References:** 49

**Title:** Formation of self-organized titania nano-tubes by dealloying and anodic oxidation ( ABSTRACT AVAILABLE )

**Publication date:** 20060100

**Journal Subject Category:** ELECTROCHEMISTRY

## Appendix A-5. Irrelevant Titles

**Descriptors:** SCIAuthor Keywords: dealloying ; nanoporous ; nanotubes ; anodic oxidation ; anatase

**Identifiers:** KeyWord Plus(R): OXIDE NANOTUBES; SELECTIVE DISSOLUTION; CARBON NANOTUBES; TIO2 NANOTUBES; ALLOYS; BEHAVIOR; ELECTROLYTES; SPECTROSCOPY; FABRICATION; EVOLUTION

7/8/762 (Item 433 from file: 34)

SciSearch(R) Cited Ref Sci

(c) 2010 The Thomson Corp. All rights reserved.

14712599 **Genuine Article#:** 997PW **Number of References:** 79

**Title:** Molecular dynamics simulation of titanium dioxide nanoparticle sintering ( ABSTRACT AVAILABLE )

**Publication date:** 20051229

**Journal Subject Category:** CHEMISTRY, PHYSICAL

**Identifiers:** KeyWord Plus(R): TO-RUTILE TRANSFORMATION; HYDROTHERMAL SYNTHESIS; NANOCRYSTALLINE TITANIA; ATOMISTIC SIMULATION; TIO2 POLYMORPHS; NANOSIZE RUTILE; GAS-PHASE; ANATASE PARTICLES; CRYSTAL-STRUCTURE; SURFACE-AREA

7/8/763 (Item 434 from file: 34)

SciSearch(R) Cited Ref Sci

(c) 2010 The Thomson Corp. All rights reserved.

14711591 **Genuine Article#:** 998ZF **Number of References:** 42

**Title:** Synthesis and characterization of titania-based monodisperse fluorescent europium nanoparticles for biolabeling ( ABSTRACT AVAILABLE )

**Publication date:** 20060300

**Journal Subject Category:** OPTICS

**Descriptors:** SCIAuthor Keywords: europium ; fluorescence ; nanoparticle ; titanium oxide ; biolabeling material

**Identifiers:** KeyWord Plus(R): RESOLVED FLUOROMETRIC APPLICATION; PROSTATE-SPECIFIC ANTIGEN; FUNCTIONALIZED SILICA-GEL; LUMINESCENCE PROPERTIES; TIO2 NANOPARTICLES; HYBRID MATERIALS; THIN-FILMS; COMPLEXES; PARTICLES; COMPOSITE

7/8/764 (Item 435 from file: 34)

SciSearch(R) Cited Ref Sci

(c) 2010 The Thomson Corp. All rights reserved.

14688335 **Genuine Article#:** 995JP **Number of References:** 21

**Title:** Controlled growth of titania nanospheres in supercritical carbon dioxide using a novel surfactant stabilised precursor ( ABSTRACT AVAILABLE )

**Publication date:** 20060000

**Journal Subject Category:** CHEMISTRY, PHYSICAL; MATERIALS SCIENCE, MULTIDISCIPLINARY

## Appendix A-5. Irrelevant Titles

**Identifiers:** KeyWord Plus(R): CHEMISTRY; FLUIDS; TIO2; PARTICLES

7/8/765 (Item 436 from file: 34)

SciSearch(R) Cited Ref Sci

(c) 2010 The Thomson Corp. All rights reserved.

14686282 **Genuine Article#:** 996PF **Number of References:** 22

**Title:** The anti-microbial activity of titania-nickel ferrite composite nanoparticles ( ABSTRACT AVAILABLE )

**Publication date:** 20051200

**Journal Subject Category:** MATERIALS SCIENCE, MULTIDISCIPLINARY; METALLURGY & METALLURGICAL ENGINEERING; MINERALOGY; MINING & MINERAL PROCESSING

**Identifiers:** KeyWord Plus(R): MAGNETICALLY SEPARATED PHOTOCATALYST; REVERSE MICELLE TECHNIQUE; INACTIVATION; BACTERIA; WATER; TIO2; DISINFECTION; DIOXIDE; VIRUSES; DYES

7/8/766 (Item 437 from file: 34)

SciSearch(R) Cited Ref Sci

(c) 2010 The Thomson Corp. All rights reserved.

14670264 **Genuine Article#:** 995LI **Number of References:** 13

**Title:** Manufacture of titanium dioxide nanocrystalline by electrochemistry ( ABSTRACT AVAILABLE )

**Publication date:** 20051000

**Journal Subject Category:** CHEMISTRY, APPLIED

**Descriptors:** SCIAuthor Keywords: titanium dioxide ; nanocrystalline ; electrochemistry

**Identifiers:** KeyWord Plus(R): LOW-TEMPERATURE; TIO2; DECOMPOSITION; POWDERS

7/8/767 (Item 438 from file: 34)

SciSearch(R) Cited Ref Sci

(c) 2010 The Thomson Corp. All rights reserved.

14658699 **Genuine Article#:** 992KC **Number of References:** 14

**Title:** Controlling the particle size of nanocrystalline titania via a thermal dissociation of substrates with ammonium chloride ( ABSTRACT AVAILABLE )

**Publication date:** 20060200

**Journal Subject Category:** MATERIALS SCIENCE, MULTIDISCIPLINARY; PHYSICS, APPLIED

**Descriptors:** SCIAuthor Keywords: anatase titania ; nanocrystals ; sol-gel method ; thermal decomposition ; solid substrate ; ammonium chloride

**Identifiers:** KeyWord Plus(R): TIO2 POWDER; ANATASE; PHASE

## Appendix A-5. Irrelevant Titles

7/8/768 (Item 439 from file: 34)

SciSearch(R) Cited Ref Sci

(c) 2010 The Thomson Corp. All rights reserved.

14637052 **Genuine Article#:** 990VP **Number of References:** 17

**Title:** Photocatalytic electron transfer in hybrid titania nanosheets studied by nanosecond laser flash photolysis ( ABSTRACT AVAILABLE )

**Publication date:** 20051105

**Journal Subject Category:** CHEMISTRY, MULTIDISCIPLINARY

**Identifiers:** KeyWord Plus(R): DIOXIDE NANOPARTICLE; SURFACE

7/8/769 (Item 440 from file: 34)

SciSearch(R) Cited Ref Sci

(c) 2010 The Thomson Corp. All rights reserved.

14620835 **Genuine Article#:** 989LP **Number of References:** 30

**Title:** On-line tracking of the coating of nanoscaled silica with titania nanoparticles via zeta-potential measurements ( ABSTRACT AVAILABLE )

**Publication date:** 20060101

**Journal Subject Category:** CHEMISTRY, PHYSICAL

**Descriptors:** SCIAuthor Keywords: titania ; silica ; Stober method ; nanoparticles ; sol ; coating ; heterogenic coagulation ; zeta-potential

**Identifiers:** KeyWord Plus(R): ELECTROACOUSTIC SPECTROSCOPY; SPHERES; SIZE; PARTICLES; ANATASE; GROWTH; RUTILE

7/8/770 (Item 441 from file: 34)

SciSearch(R) Cited Ref Sci

(c) 2010 The Thomson Corp. All rights reserved.

14598285 **Genuine Article#:** 987BX **Number of References:** 43

**Title:** Synthesis and magnetic properties of Ni nanocylinders in self-aligned and randomly disordered grown titania nanotubes ( ABSTRACT AVAILABLE )

**Publication date:** 20051100

**Journal Subject Category:** ENGINEERING, MULTIDISCIPLINARY; MATERIALS SCIENCE, MULTIDISCIPLINARY; PHYSICS, APPLIED

**Identifiers:** KeyWord Plus(R): ANODIC OXIDE-FILMS; 2-STEP REPLICATION; POROUS ALUMINA; THIN-FILMS; ARRAYS; FABRICATION; NANOWIRES; DIOXIDE; TRANSITION; HYDROGEN

7/8/771 (Item 442 from file: 34)

SciSearch(R) Cited Ref Sci

(c) 2010 The Thomson Corp. All rights reserved.

14593232 **Genuine Article#:** 985PR **Number of References:** 17

**Title:** Finishing of cotton fabrics with aqueous nano-titanium dioxide dispersion and the decomposition of gaseous ammonia by ultraviolet irradiation ( ABSTRACT

## Appendix A-5. Irrelevant Titles

AVAILABLE )

**Publication date:** 20060105

**Journal Subject Category:** POLYMER SCIENCE

**Descriptors:** SCIAuthor Keywords: degradation ; irradiation ; nanoparticles

**Identifiers:** KeyWord Plus(R): DEGRADATION; POLLUTANTS; INDOOR

7/8/772 (Item 443 from file: 34)

SciSearch(R) Cited Ref Sci

(c) 2010 The Thomson Corp. All rights reserved.

14543053 **Genuine Article#:** 982GX **Number of References:** 20

**Title:** Nanocomposites based on titanium dioxide and polythiophene: Structure and properties ( ABSTRACT AVAILABLE )

**Publication date:** 20051100

**Journal Subject Category:** CHEMISTRY, APPLIED; ENGINEERING, CHEMICAL; POLYMER SCIENCE

**Descriptors:** SCIAuthor Keywords: polythiophene ; titanium dioxide ; nanocomposites ; electrophoretic deposition ; photoelectrochemical spectra

**Identifiers:** KeyWord Plus(R): FILMS

7/8/773 (Item 444 from file: 34)

SciSearch(R) Cited Ref Sci

(c) 2010 The Thomson Corp. All rights reserved.

14521893 **Genuine Article#:** 979IA **Number of References:** 39

**Title:** Diffusion-equation approach to describe ionic mobility in nanostructured titania ( ABSTRACT AVAILABLE )

**Publication date:** 20051000

**Journal Subject Category:** PHYSICS, CONDENSED MATTER

**Identifiers:** KeyWord Plus(R): O THIN-FILMS; MICROSTRUCTURAL CHARACTERIZATION; RUTHERFORD BACKSCATTERING; THERMODYNAMIC PROPERTIES; LOW-TEMPERATURE; NANOPARTICLES; COALESCENCE; TRANSPORT

7/8/774 (Item 445 from file: 34)

SciSearch(R) Cited Ref Sci

(c) 2010 The Thomson Corp. All rights reserved.

14504737 **Genuine Article#:** 977PL **Number of References:** 39

**Title:** Nanometer titanium dioxide immobilized on silica gel as sorbent for preconcentration of metal ions prior to their determination by inductively coupled plasma atomic emission spectrometry ( ABSTRACT AVAILABLE )

**Publication date:** 20051115

**Journal Subject Category:** CHEMISTRY, ANALYTICAL

**Descriptors:** SCIAuthor Keywords: immobilized nanometer titanium dioxide ; preconcentration ; metal ions ; ICP-AES

**Identifiers:** KeyWord Plus(R): INJECTION ONLINE PRECONCENTRATION; SOLID-

## Appendix A-5. Irrelevant Titles

PHASE EXTRACTION; BEADS PACKED-COLUMN; TIO<sub>2</sub> THIN-FILM;  
ABSORPTION-SPECTROMETRY; MICRO-COLUMN; TRACE-METALS; FLOW-  
INJECTION; ICP-AES; WATER

7/8/775 (Item 446 from file: 34)

SciSearch(R) Cited Ref Sci

(c) 2010 The Thomson Corp. All rights reserved.

14469438 **Genuine Article#:** 973YJ **Number of References:** 34

**Title:** Raman spectroscopy characterization of titania nanoparticles produced by flame pyrolysis: The influence of size and stoichiometry ( ABSTRACT AVAILABLE )

**Publication date:** 20051001

**Journal Subject Category:** PHYSICS, APPLIED

**Identifiers:** KeyWord Plus(R): TIO<sub>2</sub> NANOCRYSTALS; LIGHT-SCATTERING;  
SPECTRA; ANATASE; CRYSTALS; FILMS; DIOXIDE; RUTILE

7/8/776 (Item 447 from file: 34)

SciSearch(R) Cited Ref Sci

(c) 2010 The Thomson Corp. All rights reserved.

14462696 **Genuine Article#:** 976OT **Number of References:** 14

**Title:** Bright visible photoluminescence from nanotube titania grown by soft chemical process ( ABSTRACT AVAILABLE )

**Publication date:** 20051018

**Journal Subject Category:** CHEMISTRY, PHYSICAL; MATERIALS SCIENCE,  
MULTIDISCIPLINARY

**Identifiers:** KeyWord Plus(R): TIO<sub>2</sub>; LUMINESCENCE

7/8/777 (Item 448 from file: 34)

SciSearch(R) Cited Ref Sci

(c) 2010 The Thomson Corp. All rights reserved.

14462655 **Genuine Article#:** 976PK **Number of References:** 19

**Title:** 3D nanoarchitecture from ultrathin titania film via surface sol-gel process and photolithography ( ABSTRACT AVAILABLE )

**Publication date:** 20051005

**Journal Subject Category:** CHEMISTRY, MULTIDISCIPLINARY

**Identifiers:** KeyWord Plus(R): FABRICATION; PARTICLES; MEMBRANES; SPHERES

7/8/778 (Item 449 from file: 34)

SciSearch(R) Cited Ref Sci

(c) 2010 The Thomson Corp. All rights reserved.

14460158 **Genuine Article#:** 976ON **Number of References:** 23

**Title:** Synthesis and characterization of silica-capped titania nanorods: An enhanced photocatalyst ( ABSTRACT AVAILABLE )

## Appendix A-5. Irrelevant Titles

**Publication date:** 20051004

**Journal Subject Category:** CHEMISTRY, PHYSICAL; ENVIRONMENTAL SCIENCES

**Descriptors:** SCIAuthor Keywords: photocatalyst ; titania ; nanocomposite materials ; sol-gel

**Identifiers:** KeyWord Plus(R): TRIBLOCK-COPOLYMER SYSTEMS; CDSE NANOCRYSTALS; AQUEOUS-SOLUTIONS; TIO<sub>2</sub>; SIZE; NANOPARTICLES; TIO<sub>2</sub>/SIO<sub>2</sub>; OXIDATION; CYANIDE; POWDERS

7/8/780 (Item 451 from file: 34)

SciSearch(R) Cited Ref Sci

(c) 2010 The Thomson Corp. All rights reserved.

14412832 **Genuine Article#:** 969LZ **Number of References:** 53

**Title:** Sol-gel derived silver doped nanocrystalline titania catalysed photodegradation of methylene blue from aqueous solution ( ABSTRACT AVAILABLE )

**Publication date:** 20060000

**Journal Subject Category:** CHEMISTRY, APPLIED; ENGINEERING, CHEMICAL; MATERIALS SCIENCE, TEXTILES

**Descriptors:** SCIAuthor Keywords: photodegradation ; methylene blue ; sol-gel derived TiO<sub>2</sub> ; silver doping ; common inorganic salts

**Identifiers:** KeyWord Plus(R): HETEROGENEOUS PHOTOCATALYTIC DECOMPOSITION; SONOCHEMICAL SYNTHESIS; HYDROGEN-PEROXIDE; TIO<sub>2</sub> PARTICLES; ORGANIC-CARBON; THIN-FILMS; DEGRADATION; ANATASE; DYES; WATER

7/8/781 (Item 452 from file: 34)

SciSearch(R) Cited Ref Sci

(c) 2010 The Thomson Corp. All rights reserved.

14403582 **Genuine Article#:** 965YN **Number of References:** 5

**Title:** Preparation and characterization of nanometer titania-coated silica particles ( ABSTRACT AVAILABLE )

**Publication date:** 20050600

**Journal Subject Category:** MATERIALS SCIENCE, MULTIDISCIPLINARY; METALLURGY & METALLURGICAL ENGINEERING

**Descriptors:** SCIAuthor Keywords: nanometer TiO<sub>2</sub>-coated silica particles ; microemulsion technology ; sol-gel **process** ; chemical bond

7/8/782 (Item 453 from file: 34)

SciSearch(R) Cited Ref Sci

(c) 2010 The Thomson Corp. All rights reserved.

14335923 **Genuine Article#:** 963FS **Number of References:** 15

**Title:** Close-packed colloidal crystalline arrays composed of polystyrene latex coated with titania nanosheets ( ABSTRACT AVAILABLE )

**Publication date:** 20050913

**Journal Subject Category:** CHEMISTRY, PHYSICAL

## Appendix A-5. Irrelevant Titles

**Identifiers:** KeyWord Plus(R): CORE-SHELL PARTICLES; EMULSION  
POLYMERIZATION; PHOTONIC CRYSTALS; IONIC COMONOMER; SPHERES

7/8/783 (Item 454 from file: 34)

SciSearch(R) Cited Ref Sci

(c) 2010 The Thomson Corp. All rights reserved.

14335920 **Genuine Article#:** 963FS **Number of References:** 39

**Title:** Nanocopying of individual DNA strands and formation of the corresponding surface pattern of titania nanotube ( ABSTRACT AVAILABLE )

**Publication date:** 20050913

**Journal Subject Category:** CHEMISTRY, PHYSICAL

**Identifiers:** KeyWord Plus(R): WALLED CARBON NANOTUBES; ROOM-TEMPERATURE; METAL NANOSTRUCTURES; NANOWIRE FORMATION; HYDROGEN STORAGE; HOLLOW INTERIORS; SINGLE; TEMPLATES; SILICA; TRANSCRIPTION

7/8/784 (Item 455 from file: 34)

SciSearch(R) Cited Ref Sci

(c) 2010 The Thomson Corp. All rights reserved.

14334156 **Genuine Article#:** 962VC **Number of References:** 29

**Title:** Humidity sensing properties of nanostructured-bilayered potassium tantalate: Titania films ( ABSTRACT AVAILABLE )

**Publication date:** 20050800

**Journal Subject Category:** ENGINEERING, ELECTRICAL & ELECTRONIC; MATERIALS SCIENCE, MULTIDISCIPLINARY; PHYSICS, CONDENSED MATTER

**Identifiers:** KeyWord Plus(R): TIO2 THIN-FILMS; SENSORS; OXIDE; TIN

7/8/785 (Item 456 from file: 34)

SciSearch(R) Cited Ref Sci

(c) 2010 The Thomson Corp. All rights reserved.

14333106 **Genuine Article#:** 961RY **Number of References:** 36

**Title:** Ultrathin films of tetrasulfonated copper phthalocyanine-capped titanium dioxide nanoparticles: Fabrication, characterization, and photovoltaic effect ( ABSTRACT AVAILABLE )

**Publication date:** 20051001

**Journal Subject Category:** CHEMISTRY, PHYSICAL

**Descriptors:** SCIAuthor Keywords: phthalocyanine ; titanium dioxide ; layer-by-layer ; electrochemistry ; photovoltaic

**Identifiers:** KeyWord Plus(R): ELECTROCHEMICALLY ASSISTED PHOTOCATALYSIS; NANOSTRUCTURED TIO2 ELECTRODE; PHOTOELECTRIC CONVERSION; SPECTRAL SENSITIZATION; SURFACE; SEMICONDUCTOR; AGGREGATION; OXIDE; 4-CHLOROPHENOL; DEGRADATION

## Appendix A-5. Irrelevant Titles

7/8/786 (Item 457 from file: 34)

SciSearch(R) Cited Ref Sci

(c) 2010 The Thomson Corp. All rights reserved.

14312451 **Genuine Article#:** 960OF **Number of References:** 39

**Title:** Synthesis of Iron(III)-doped titania nanoparticles and its application for photodegradation of sulforhodamine-B pollutant ( ABSTRACT AVAILABLE )

**Publication date:** 20051000

**Journal Subject Category:** CHEMISTRY, MULTIDISCIPLINARY; MATERIALS SCIENCE, MULTIDISCIPLINARY

**Descriptors:** SCIAuthor Keywords: iron(III)-doped titania ; photocatalysis ; sol-gel ; sulforhodamine-B ; titania ; visible light ; nanotechnology ; water quality

**Identifiers:** KeyWord Plus(R): DOPED TIO2 PHOTOCATALYST; VISIBLE-LIGHT; SEMICONDUCTOR PHOTOCATALYSIS; IRRADIATION; PHOTOOXIDATION; DEGRADATION; PARTICLES; CHROMIUM; SURFACES; DIOXIDE

7/8/787 (Item 458 from file: 34)

SciSearch(R) Cited Ref Sci

(c) 2010 The Thomson Corp. All rights reserved.

14277400 **Genuine Article#:** 957MS **Number of References:** 22

**Title:** Nanoglued titanium dioxide aerogels for photocatalysis ( ABSTRACT AVAILABLE )

**Publication date:** 20050900

**Journal Subject Category:** ENGINEERING, ENVIRONMENTAL; ENVIRONMENTAL SCIENCES

**Descriptors:** SCIAuthor Keywords: photodegradation ; photocatalysis ; advanced oxidation processes ; TiO2

**Identifiers:** KeyWord Plus(R): TIO2 AEROGELS; WATER; SILICA; SURFACE; DEGRADATION; PHENOL

7/8/788 (Item 459 from file: 34)

SciSearch(R) Cited Ref Sci

(c) 2010 The Thomson Corp. All rights reserved.

14272314 **Genuine Article#:** BCO63 **Number of References:** 10

**Title:** Preparation of bioactive nanophase Titania ceramics by alkali-heat ( ABSTRACT AVAILABLE )

**Publication date:** 20050000

**Journal Subject Category:** MATERIALS SCIENCE, CERAMICS; MATERIALS SCIENCE, COMPOSITES

**Descriptors:** SCIAuthor Keywords: bioactive nanophase titania ceramics ; sodium titanate ; bonelike apatite ; alkali-heat treatment ; FCS

## Appendix A-5. Irrelevant Titles

7/8/789 (Item 460 from file: 34)

SciSearch(R) Cited Ref Sci

(c) 2010 The Thomson Corp. All rights reserved.

14272303 **Genuine Article#:** BCO63 **Number of References:** 9

**Title:** In vitro bioactivity of composite of nanophase titania /bioactive glass-ceramic in simulated body fluid ( ABSTRACT AVAILABLE )

**Publication date:** 20050000

**Journal Subject Category:** MATERIALS SCIENCE, CERAMICS; MATERIALS SCIENCE, COMPOSITES

**Descriptors:** SCIAuthor Keywords: bioactivity ; composites ; glass ceramic ; TiO<sub>2</sub> ; hydroxyapatite

**Identifiers:** KeyWord Plus(R): IMPLANTS

7/8/790 (Item 461 from file: 34)

SciSearch(R) Cited Ref Sci

(c) 2010 The Thomson Corp. All rights reserved.

14265908 **Genuine Article#:** 955FE **Number of References:** 21

**Title:** Photocatalytic activity of titania nanocrystals prepared by surfactant-assisted templating method - Effect of calcination conditions ( ABSTRACT AVAILABLE )

**Publication date:** 20051000

**Journal Subject Category:** MATERIALS SCIENCE, MULTIDISCIPLINARY; PHYSICS, APPLIED

**Descriptors:** SCIAuthor Keywords: titania ; photocatalytic activity ; surfactant-assisted templating method ; anatase

**Identifiers:** KeyWord Plus(R): RUTILE TIO<sub>2</sub>; DEGRADATION; DIOXIDE; ANATASE

7/8/791 (Item 462 from file: 34)

SciSearch(R) Cited Ref Sci

(c) 2010 The Thomson Corp. All rights reserved.

14242683 **Genuine Article#:** 952PU **Number of References:** 42

**Title:** Preparation of lanthana-doped titania nanoparticles with anatase mesoporous walls and high photocatalytic activity ( ABSTRACT AVAILABLE )

**Publication date:** 20050901

**Journal Subject Category:** CHEMISTRY, PHYSICAL

**Descriptors:** SCIAuthor Keywords: lanthana doped ; mesoporous materials ; Titania ; nanoparticles ; anatase

**Identifiers:** KeyWord Plus(R): NANOCRYSTALLINE TITANIA; TIO<sub>2</sub> PARTICLES; SURFACE-AREA; THIN-FILMS; DIOXIDE; OXIDE; PORE; DEGRADATION; REACTIVITY; STABILITY

7/8/792 (Item 463 from file: 34)

SciSearch(R) Cited Ref Sci

(c) 2010 The Thomson Corp. All rights reserved.

## Appendix A-5. Irrelevant Titles

14197934 **Genuine Article#:** 948CV **Number of References:** 26

**Title:** Increased osteoblast functions on nanophase titania dispersed in poly-lactic-co-glycolic acid composites ( ABSTRACT AVAILABLE )

**Publication date:** 20050700

**Journal Subject Category:** ENGINEERING, MULTIDISCIPLINARY; MATERIALS SCIENCE, MULTIDISCIPLINARY; PHYSICS, APPLIED

**Identifiers:** KeyWord Plus(R): TISSUE ENGINEERING SCAFFOLDS; IN-VITRO; BONE; CERAMICS; ALUMINA; DEGRADATION; ADHESION; FOAMS

7/8/793 (Item 464 from file: 34)

SciSearch(R) Cited Ref Sci

(c) 2010 The Thomson Corp. All rights reserved.

14173541 **Genuine Article#:** 947HX **Number of References:** 23

**Title:** Raman study of titania nanotube by soft chemical process ( ABSTRACT AVAILABLE )

**Publication date:** 20050715

**Journal Subject Category:** CHEMISTRY, PHYSICAL

**Descriptors:** SCIAuthor Keywords: Raman spectra ; titania nanotube ; soft chemical process

**Identifiers:** KeyWord Plus(R): FORMATION MECHANISM; CARBON NANOTUBES; TIO<sub>2</sub>; SCATTERING

7/8/794 (Item 465 from file: 34)

SciSearch(R) Cited Ref Sci

(c) 2010 The Thomson Corp. All rights reserved.

14098821 **Genuine Article#:** 941DO **Number of References:** 29

**Title:** Polyimide/silica/titania nanohybrids via a novel non-hydrolytic sol-gel route ( ABSTRACT AVAILABLE )

**Publication date:** 20050000

**Journal Subject Category:** ENGINEERING, MANUFACTURING; MATERIALS SCIENCE, COMPOSITES

**Descriptors:** SCIAuthor Keywords: nano-structures ; polymer-matrix composites (PMCs) ; optical properties techniques ; thermal properties

**Identifiers:** KeyWord Plus(R): POLYIMIDE-SILICA HYBRIDS; THIN-FILMS; OPTICAL-PROPERTIES; COMPOSITES; NANOCOMPOSITES; MORPHOLOGY; TITANIA; PRECURSORS; ACID)

7/8/795 (Item 466 from file: 34)

SciSearch(R) Cited Ref Sci

(c) 2010 The Thomson Corp. All rights reserved.

14091760 **Genuine Article#:** 913TZ **Number of References:** 0

**Title:** Impact of titania and quartz nanoparticulate exposures on respiratory health: Role of particle size.

**Publication date:** 20050313

## Appendix A-5. Irrelevant Titles

**Journal Subject Category:** CHEMISTRY, MULTIDISCIPLINARY

7/8/796 (Item 467 from file: 34)

SciSearch(R) Cited Ref Sci

(c) 2010 The Thomson Corp. All rights reserved.

14084175 **Genuine Article#:** 938JQ **Number of References:** 19

**Title:** Ambient temperature growth of nanocrystalline titanium dioxide thin films ( ABSTRACT AVAILABLE )

**Publication date:** 20050700

**Journal Subject Category:** PHYSICS, CONDENSED MATTER

**Descriptors:** SCIAuthor Keywords: nanostructures ; thin films ; crystal structure and symmetry ; optical properties

**Identifiers:** KeyWord Plus(R): BEAM-ASSISTED DEPOSITION; TIO2 FILMS; OPTICAL-PROPERTIES

7/8/797 (Item 468 from file: 34)

SciSearch(R) Cited Ref Sci

(c) 2010 The Thomson Corp. All rights reserved.

14073211 **Genuine Article#:** 936PG **Number of References:** 52

**Title:** Calculated structural and electronic interactions of the ruthenium dye N3 with a titanium dioxide nanocrystal ( ABSTRACT AVAILABLE )

**Publication date:** 20050623

**Journal Subject Category:** CHEMISTRY, PHYSICAL

**Identifiers:** KeyWord Plus(R): EFFECTIVE CORE POTENTIALS; BI-ISONICOTINIC ACID; DENSITY-FUNCTIONAL THEORY; MOLECULAR CALCULATIONS; CHARGE-TRANSFER; ABSORPTION-SPECTRUM; TIO2 NANOPARTICLES; TRANSFER DYNAMICS; EXCITED-STATES; SEMICONDUCTOR

7/8/798 (Item 469 from file: 34)

SciSearch(R) Cited Ref Sci

(c) 2010 The Thomson Corp. All rights reserved.

14048797 **Genuine Article#:** 936NB **Number of References:** 29

**Title:** Hydrothermal synthesis, characterization, and photocatalytic performance of silica-modified titanium dioxide nanoparticles ( ABSTRACT AVAILABLE )

**Publication date:** 20050801

**Journal Subject Category:** CHEMISTRY, PHYSICAL

**Descriptors:** SCIAuthor Keywords: titanium dioxide ; silica ; hydrothermal ; anatase ; photocatalytic

**Identifiers:** KeyWord Plus(R): SOL-GEL; TIO2 NANOPARTICLES; NANOCRYSTALLINE TITANIA; PHASE-TRANSFORMATION; MIXED OXIDES; ANATASE; PARTICLES; TIO2/SIO2

## Appendix A-5. Irrelevant Titles

7/8/799 (Item 470 from file: 34)

SciSearch(R) Cited Ref Sci

(c) 2010 The Thomson Corp. All rights reserved.

14036548 **Genuine Article#:** 934SS **Number of References:** 66

**Title:** Ligand functionality as a versatile tool to control the assembly behavior of preformed titania nanocrystals ( ABSTRACT AVAILABLE )

**Publication date:** 20050606

**Journal Subject Category:** CHEMISTRY, MULTIDISCIPLINARY

**Descriptors:** SCIAuthor Keywords: anatase ; nanoparticle assembly ; nanostructures ; nonaqueous synthesis ; surface chemistry

**Identifiers:** KeyWord Plus(R): LOW-TEMPERATURE SYNTHESIS; NONAQUEOUS SYNTHESIS; ORIENTED ATTACHMENT; REACTION SYSTEM; BENZYL ALCOHOL; NANOPARTICLES; OXIDE; TIO<sub>2</sub>; NANORODS; NANOWIRES

7/8/800 (Item 471 from file: 34)

SciSearch(R) Cited Ref Sci

(c) 2010 The Thomson Corp. All rights reserved.

13977008 **Genuine Article#:** 928TD **Number of References:** 25

**Title:** Preparation of a transparent and flexible self-standing film of layered titania/isostearate nanocomposite ( ABSTRACT AVAILABLE )

**Publication date:** 20050500

**Journal Subject Category:** MATERIALS SCIENCE, MULTIDISCIPLINARY

**Identifiers:** KeyWord Plus(R): SOL-GEL PROCESS; TITANIUM-OXIDE; SILICA FILMS; TIO<sub>2</sub>; CHEMISTRY; CATALYSTS; POLYMERS; COATINGS; ALKOXIDE

7/8/801 (Item 472 from file: 34)

SciSearch(R) Cited Ref Sci

(c) 2010 The Thomson Corp. All rights reserved.

13956122 **Genuine Article#:** 928AP **Number of References:** 52

**Title:** High-density arrays of titania nanoparticles using monolayer micellar films of diblock copolymers as templates ( ABSTRACT AVAILABLE )

**Publication date:** 20050524

**Journal Subject Category:** CHEMISTRY, PHYSICAL

**Identifiers:** KeyWord Plus(R): BLOCK-COPOLYMERS; THIN-FILMS; NANOSPHERE LITHOGRAPHY; NANOWIRE ARRAYS; SILICON-OXIDE; TIO<sub>2</sub>; SURFACES; NANOSTRUCTURES; POLYMERS; POLYSTYRENE-BLOCK-POLY(4-VINYLPYRIDINE)

7/8/802 (Item 473 from file: 34)

SciSearch(R) Cited Ref Sci

(c) 2010 The Thomson Corp. All rights reserved.

## Appendix A-5. Irrelevant Titles

13954709 **Genuine Article#:** 925SE **Number of References:** 30

**Title:** Structural and microstructural evolution during pyrolysis of hybrid polydimethylsiloxane-titania nanocomposites ( ABSTRACT AVAILABLE )

**Publication date:** 20050400

**Journal Subject Category:** MATERIALS SCIENCE, CERAMICS

**Descriptors:** SCIAuthor Keywords: polydimethylsiloxane-oxide hybrids ; nanocomposites ; pyrolysis ; silicon oxycarbide ; TiC

**Identifiers:** KeyWord Plus(R): SILOXANE-OXIDE MATERIALS; SILICON OXYCARBIDE; RIETVELD METHOD; PHASE; CHEMISTRY; ZIRCONIUM; DESIGN; GLASS; NMR

7/8/803 (Item 474 from file: 34)

SciSearch(R) Cited Ref Sci

(c) 2010 The Thomson Corp. All rights reserved.

13954421 **Genuine Article#:** 927BE **Number of References:** 23

**Title:** Physicochemical and electrochemical characterization of anatase titanium dioxide nanoparticles ( ABSTRACT AVAILABLE )

**Publication date:** 20050427

**Journal Subject Category:** ELECTROCHEMISTRY; ENERGY & FUELS

**Descriptors:** SCIAuthor Keywords: nano-sized TiO<sub>2</sub> ; anatase ; electrochemical lithium insertion

**Identifiers:** KeyWord Plus(R): LITHIUM INSERTION; TIO<sub>2</sub> ANATASE; OXIDE; INTERCALATION; TIO<sub>2</sub>(110); GROWTH; FILMS

7/8/804 (Item 475 from file: 34)

SciSearch(R) Cited Ref Sci

(c) 2010 The Thomson Corp. All rights reserved.

13953491 **Genuine Article#:** 926JQ **Number of References:** 25

**Title:** Vapor-phase photo-oxidation of methanol over nano-size titanium dioxide clusters dispersed in MCM-41 host material part 2: Catalytic properties and surface transient species ( ABSTRACT AVAILABLE )

**Publication date:** 20050500

**Journal Subject Category:** CHEMISTRY, MULTIDISCIPLINARY; MATERIALS SCIENCE, MULTIDISCIPLINARY

**Descriptors:** SCIAuthor Keywords: photocatalytic oxidation ; oxidation of methanol ; nanodispersed titania ; MCM-41

**Identifiers:** KeyWord Plus(R): FT-IR; OXIDE CATALYSTS; TIO<sub>2</sub>; ADSORPTION; ALCOHOLS; PHOTOCATALYSIS; DECOMPOSITION; REACTIVITY; OXIDATION; MECHANISM

7/8/806 (Item 477 from file: 34)

SciSearch(R) Cited Ref Sci

(c) 2010 The Thomson Corp. All rights reserved.

## Appendix A-5. Irrelevant Titles

13898338 **Genuine Article#:** 921WU **Number of References:** 18

**Title:** A novel approach to synthesis of high-dispersed anatase titania nanocrystals ( ABSTRACT AVAILABLE )

**Publication date:** 20050600

**Journal Subject Category:** MATERIALS SCIENCE, MULTIDISCIPLINARY; PHYSICS, APPLIED

**Descriptors:** SCIAuthor Keywords: anatase titania ; high-dispersed ; nanocrystals ; needle-shape ; sol-gel **process** ; forming solid substrates

**Identifiers:** KeyWord Plus(R): SOL-GEL METHOD; AMORPHOUS TITANIA; AMMONIUM-NITRATE; PARTICLE-SIZE; TEMPERATURE; POWDER; PHASE

7/8/807 (Item 478 from file: 34)

SciSearch(R) Cited Ref Sci

(c) 2010 The Thomson Corp. All rights reserved.

13877684 **Genuine Article#:** 910FA **Number of References:** 22

**Title:** Synthesis of bundle-like structure of titania nanotubes ( ABSTRACT AVAILABLE )

**Publication date:** 20050400

**Journal Subject Category:** MATERIALS SCIENCE, MULTIDISCIPLINARY; PHYSICS, APPLIED

**Descriptors:** SCIAuthor Keywords: bundle-like structure ; nanotube ; nanobelt ; chemical **process** ; titania

**Identifiers:** KeyWord Plus(R): TIO2 NANOTUBES; POROUS TITANIA; FABRICATION; RUTILE

7/8/808 (Item 479 from file: 34)

SciSearch(R) Cited Ref Sci

(c) 2010 The Thomson Corp. All rights reserved.

13862707 **Genuine Article#:** BBZ54 **Number of References:** 4

**Title:** New bioactive bone cement containing nano-sized titania particles ( ABSTRACT AVAILABLE )

**Publication date:** 20050000

**Journal Subject Category:** MATERIALS SCIENCE, CERAMICS; MATERIALS SCIENCE, COMPOSITES

**Descriptors:** SCIAuthor Keywords: bioactive ; osteoconductivity ; polymethylmethacrylate ; titania

7/8/809 (Item 480 from file: 34)

SciSearch(R) Cited Ref Sci

(c) 2010 The Thomson Corp. All rights reserved.

13843361 **Genuine Article#:** 918BG **Number of References:** 33

**Title:** Photodegradation of ethylene using visible light responsive surfaces prepared from titania nanoparticle slurries ( ABSTRACT AVAILABLE )

**Publication date:** 20050428

## Appendix A-5. Irrelevant Titles

**Journal Subject Category:** CHEMISTRY, PHYSICAL; ENGINEERING, ENVIRONMENTAL

**Descriptors:** SCIAuthor Keywords: TiO<sub>2</sub> ; titania ; nanoparticle ; visible light responsive ; nitridation ; nitrogen doping ; metal seeding ; photocatalysis ; ethylene oxidation ; stop-flow reactor

**Identifiers:** KeyWord Plus(R): YAG LASER IRRADIATION; PHOTOELECTRON-SPECTROSCOPY; PHOTOCATALYTIC OXIDATION; TIO<sub>2</sub> NANOPARTICLES; THIN-FILMS; TEMPERATURE; DEGRADATION; NITROGEN; WATER; ABSORPTION

7/8/810 (Item 481 from file: 34)

SciSearch(R) Cited Ref Sci

(c) 2010 The Thomson Corp. All rights reserved.

13833828 **Genuine Article#:** 916AW **Number of References:** 11

**Title:** Preparation of titanium dioxide nanocrystallite with high photocatalytic activities ( ABSTRACT AVAILABLE )

**Publication date:** 20050400

**Journal Subject Category:** MATERIALS SCIENCE, CERAMICS

**Identifiers:** KeyWord Plus(R): HYDROTHERMAL SYNTHESIS; TIO<sub>2</sub>; ANATASE; POWDERS; CALCINATION; HYDROLYSIS; PARTICLES

7/8/811 (Item 482 from file: 34)

SciSearch(R) Cited Ref Sci

(c) 2010 The Thomson Corp. All rights reserved.

13816829 **Genuine Article#:** 913MH **Number of References:** 9

**Title:** Nanometer-size titanium dioxide separation/preconcentration and ICP-AES for the determination of Cd, Co and Zn ( ABSTRACT AVAILABLE )

**Publication date:** 20050300

**Journal Subject Category:** SPECTROSCOPY

**Descriptors:** SCIAuthor Keywords: nanometer-size TiO<sub>2</sub> ; preconcentration ; ICP-AES ; Cd ; Co ; Zn

**Identifiers:** KeyWord Plus(R): PARTICLES; SPECTROMETRY

7/8/812 (Item 483 from file: 34)

SciSearch(R) Cited Ref Sci

(c) 2010 The Thomson Corp. All rights reserved.

13784390 **Genuine Article#:** 911HS **Number of References:** 18

**Title:** Synthesis of highly active sulfate-promoted rutile titania nanoparticles with a response to visible light ( ABSTRACT AVAILABLE )

**Publication date:** 20050331

**Journal Subject Category:** CHEMISTRY, PHYSICAL

**Identifiers:** KeyWord Plus(R): PHOTOCATALYTIC OXIDATION; TIO<sub>2</sub>

## Appendix A-5. Irrelevant Titles

7/8/813 (Item 484 from file: 34)

SciSearch(R) Cited Ref Sci

(c) 2010 The Thomson Corp. All rights reserved.

13777515 **Genuine Article#:** 910MF **Number of References:** 46

**Title:** Microstructure, interfacial interaction, and properties of polyimide/poly(vinylsilsesquioxane)/titania ternary hybrid nanocomposites ( ABSTRACT AVAILABLE )

**Publication date:** 20050000

**Journal Subject Category:** MATERIALS SCIENCE, COMPOSITES

**Descriptors:** SCIAuthor Keywords: polyimide ; hybrid ; nanocomposites ; silsesquioxane ; titania ; sol-gel reaction

**Identifiers:** KeyWord Plus(R): GLYCIDOXYPROPYLTRIMETHOXYSILANE-WATER-TITANIUMTETRAETHOXIDE; THIN-FILMS; WAVE-GUIDES; POLYIMIDE; SILICA; GEL; COMPOSITES; SPECTROSCOPY; PRECURSORS; MORPHOLOGY

7/8/814 (Item 485 from file: 34)

SciSearch(R) Cited Ref Sci

(c) 2010 The Thomson Corp. All rights reserved.

13770169 **Genuine Article#:** 909SW **Number of References:** 28

**Title:** Preparation and humidity sensing behaviors of nanostructured potassium tantalate: titania films ( ABSTRACT AVAILABLE )

**Publication date:** 20050328

**Journal Subject Category:** CHEMISTRY, ANALYTICAL; ELECTROCHEMISTRY; INSTRUMENTS & INSTRUMENTATION

**Descriptors:** SCIAuthor Keywords: nanostructure ; bilayered film ; humidity sensor

**Identifiers:** KeyWord Plus(R): TIO2 THIN-FILMS; CERAMIC SENSORS; OXIDE; TIN

7/8/815 (Item 486 from file: 34)

SciSearch(R) Cited Ref Sci

(c) 2010 The Thomson Corp. All rights reserved.

13731931 **Genuine Article#:** 907RB **Number of References:** 36

**Title:** Synthesis of titanium dioxide nanoparticles with mesoporous anatase wall and high photocatalytic activity ( ABSTRACT AVAILABLE )

**Publication date:** 20050324

**Journal Subject Category:** CHEMISTRY, PHYSICAL

**Identifiers:** KeyWord Plus(R): TIO2 PARTICLES; SURFACE-AREA; RUTILE; OXIDE; STABILITY; POLYMERS; BEHAVIOR; MIXTURE

7/8/816 (Item 487 from file: 34)

SciSearch(R) Cited Ref Sci

(c) 2010 The Thomson Corp. All rights reserved.

13635469 **Genuine Article#:** 899CX **Number of References:** 36

**Title:** Formation and characterization of titania nanosheet -precipitated coatings via

## Appendix A-5. Irrelevant Titles

**sol-gel process with hot water treatment under vibration** ( ABSTRACT AVAILABLE )

**Publication date:** 20050222

**Journal Subject Category:** CHEMISTRY, PHYSICAL; MATERIALS SCIENCE, MULTIDISCIPLINARY

**Identifiers:** KeyWord Plus(R): HYDROPHILIC PROPERTY; STRUCTURAL-CHANGES; HIGH-TEMPERATURE; CRYSTAL-GROWTH; SIO2-TIO2 GEL; HIGH HUMIDITY; FILMS; SURFACES; PHOTOCATALYSIS; TETRATITANATE

7/8/817 (Item 488 from file: 34)

SciSearch(R) Cited Ref Sci

(c) 2010 The Thomson Corp. All rights reserved.

13621001 **Genuine Article#:** 897YG **Number of References:** 25

**Title: Synthesis, characterization, and photocatalytic activity for hydrogen evolution of nanocrystalline mesoporous titania prepared by surfactant-assisted templating sol-gel process** ( ABSTRACT AVAILABLE )

**Publication date:** 20050100

**Journal Subject Category:** CHEMISTRY, INORGANIC & NUCLEAR; CHEMISTRY, PHYSICAL

**Descriptors:** SCIAuthor Keywords: sol-gel **process** ; surfactant-assisted template ; mesoporous titania ; photocatalysis ; hydrogen evolution ; crystallinity ; anatase phase

**Identifiers:** KeyWord Plus(R): SEMICONDUCTOR PHOTOCATALYSIS; TIO2; WATER; PARTICLES; OXIDE

7/8/818 (Item 489 from file: 34)

SciSearch(R) Cited Ref Sci

(c) 2010 The Thomson Corp. All rights reserved.

13568993 **Genuine Article#:** 893KN **Number of References:** 16

**Title: Photocatalytic evolution of hydrogen over nanocrystalline mesoporous titania prepared by surfactant-assisted templating sol-gel process** ( ABSTRACT AVAILABLE )

**Publication date:** 20050200

**Journal Subject Category:** CHEMISTRY, PHYSICAL

**Descriptors:** SCIAuthor Keywords: photocatalysis ; hydrogen evolution ; mesoporous titania ; surfactant-assisted template ; sol-gel **process**

**Identifiers:** KeyWord Plus(R): TIO2; WATER; PARTICLES

7/8/819 (Item 490 from file: 34)

SciSearch(R) Cited Ref Sci

(c) 2010 The Thomson Corp. All rights reserved.

13554921 **Genuine Article#:** 890SV **Number of References:** 17

**Title: Zinc ions surface-doped titanium dioxide nanotubes and its photocatalysis activity**

## Appendix A-5. Irrelevant Titles

**for degradation of methyl orange in water ( ABSTRACT AVAILABLE )**

**Publication date:** 20050201

**Journal Subject Category:** CHEMISTRY, PHYSICAL

**Descriptors:** SCIAuthor Keywords: titanium dioxide ; nanotubes ; doping ; zinc ions ; surface

**Identifiers:** KeyWord Plus(R): QUANTUM-SIZED TIO<sub>2</sub>; ACETYLACETONATE; DOPANTS

7/8/820 (Item 491 from file: 34)

SciSearch(R) Cited Ref Sci

(c) 2010 The Thomson Corp. All rights reserved.

13521026 **Genuine Article#:** 888RH **Number of References:** 26

**Title: Effect of substrate type on nanostructured titania sol-gel coatings for sensors applications ( ABSTRACT AVAILABLE )**

**Publication date:** 20050000

**Journal Subject Category:** MATERIALS SCIENCE, CERAMICS

**Descriptors:** SCIAuthor Keywords: films ; sol-gel **processes** ; TiO<sub>2</sub> ; sensors ; substrates

**Identifiers:** KeyWord Plus(R): ANATASE-RUTILE TRANSITION; THIN-FILMS; CRYSTAL-STRUCTURES; OXYGEN SENSORS; TIO<sub>2</sub>; DEPOSITION; PHASE; DIOXIDE; OXIDES

7/8/821 (Item 492 from file: 34)

SciSearch(R) Cited Ref Sci

(c) 2010 The Thomson Corp. All rights reserved.

13503824 **Genuine Article#:** 886UF **Number of References:** 34

**Title: An aqueous sol-gel route to synthesize nanosized lanthanadoped titania having an increased anatase phase stability for photocatalytic application ( ABSTRACT AVAILABLE )**

**Publication date:** 20050315

**Journal Subject Category:** MATERIALS SCIENCE, MULTIDISCIPLINARY

**Descriptors:** SCIAuthor Keywords: sol-gel ; titanyl sulphate ; photocatalyst ; anatase ; rutile

**Identifiers:** KeyWord Plus(R): TIO<sub>2</sub> ULTRAFINE POWDERS; RUTILE TRANSFORMATION; NANOCRYSTALLINE TITANIA; PRECIPITATION; ATMOSPHERE; KINETICS; BEHAVIOR; OXIDE

7/8/822 (Item 493 from file: 34)

SciSearch(R) Cited Ref Sci

(c) 2010 The Thomson Corp. All rights reserved.

13497327 **Genuine Article#:** 885VW **Number of References:** 17

**Title: Study on the formation process of titania nanohole arrays ( ABSTRACT AVAILABLE )**

**Publication date:** 20050111

**Journal Subject Category:** CHEMISTRY, PHYSICAL; MATERIALS SCIENCE, MULTIDISCIPLINARY; METALLURGY & METALLURGICAL ENGINEERING

## Appendix A-5. Irrelevant Titles

**Descriptors:** SCIAuthor Keywords: nanostructure ; nanofabrication ; chemical synthesis ; thin films

**Identifiers:** KeyWord Plus(R): LIQUID-PHASE DEPOSITION; OXIDE THIN-FILMS; FABRICATION; ALUMINUM; NANOSTRUCTURES; GROWTH

7/8/823 (Item 494 from file: 34)

SciSearch(R) Cited Ref Sci

(c) 2010 The Thomson Corp. All rights reserved.

13416418 **Genuine Article#:** 877PP **Number of References:** 12

**Title:** Structure of nanocrystalline titania ceramics studied by x-ray diffraction, atomic force microscopy, and thermal phonon kinetics ( ABSTRACT AVAILABLE )

**Publication date:** 20041100

**Journal Subject Category:** MATERIALS SCIENCE, MULTIDISCIPLINARY

7/8/824 (Item 495 from file: 34)

SciSearch(R) Cited Ref Sci

(c) 2010 The Thomson Corp. All rights reserved.

13411668 **Genuine Article#:** 878WX **Number of References:** 18

**Title:** A simple method to synthesize nanowires titanium dioxide from layered titanate particles ( ABSTRACT AVAILABLE )

**Publication date:** 20041211

**Journal Subject Category:** PHYSICS, ATOMIC, MOLECULAR & CHEMICAL

**Identifiers:** KeyWord Plus(R): TIO2; NANOTUBES; GROWTH; ARRAYS

7/8/825 (Item 496 from file: 34)

SciSearch(R) Cited Ref Sci

(c) 2010 The Thomson Corp. All rights reserved.

13405486 **Genuine Article#:** 874ZW **Number of References:** 51

**Title:** The application of inverse titania opals in nanostructured solar cells ( ABSTRACT AVAILABLE )

**Publication date:** 20050101

**Journal Subject Category:** ENERGY & FUELS; MATERIALS SCIENCE, MULTIDISCIPLINARY

**Descriptors:** SCIAuthor Keywords: inverse opals ; photonic crystals ; solar cells ; nanostructures ; titanium dioxide

**Identifiers:** KeyWord Plus(R): FILM PHOTONIC CRYSTALS; OPTICAL-PROPERTIES; LARGE AREAS; MESOSCALE PARTICLES; COLLOIDAL CRYSTALS; EMULSION DROPLETS; POROUS STRUCTURE; LATEX-PARTICLES; COMPOSITE FILMS; SPHERES

7/8/826 (Item 497 from file: 34)

SciSearch(R) Cited Ref Sci

## Appendix A-5. Irrelevant Titles

(c) 2010 The Thomson Corp. All rights reserved.

13364002 **Genuine Article#:** 871TH **Number of References:** 26

**Title:** Erbia-modified electrospun titania nanofibres for selective infrared emitters ( ABSTRACT AVAILABLE )

**Publication date:** 20041020

**Journal Subject Category:** PHYSICS, CONDENSED MATTER

**Identifiers:** KeyWord Plus(R): THERMOPHOTOVOLTAIC ENERGY-CONVERSION; POLYMER TEMPLATE FIBERS; FABRICATION; COMPOSITES; METAL

7/8/827 (Item 498 from file: 34)

SciSearch(R) Cited Ref Sci

(c) 2010 The Thomson Corp. All rights reserved.

13355807 **Genuine Article#:** 871RJ **Number of References:** 14

**Title:** Preparation of nitrogen-doped anatase titania by treatment of layered titania/isostearate nanocomposite with aqueous ammonia ( ABSTRACT AVAILABLE )

**Publication date:** 20041105

**Journal Subject Category:** CHEMISTRY, MULTIDISCIPLINARY

**Identifiers:** KeyWord Plus(R): DIOXIDE; TIO<sub>2</sub>; PHOTOCATALYST; OXIDE; ADSORPTION; FILMS

7/8/828 (Item 499 from file: 34)

SciSearch(R) Cited Ref Sci

(c) 2010 The Thomson Corp. All rights reserved.

13344071 **Genuine Article#:** 870UJ **Number of References:** 31

**Title:** Highly efficient dye-sensitized solar cells with a titania thin-film electrode composed of a network structure of single-crystal-like TiO<sub>2</sub> nanowires made by the "oriented attachment" mechanism ( ABSTRACT AVAILABLE )

**Publication date:** 20041117

**Journal Subject Category:** CHEMISTRY, MULTIDISCIPLINARY

**Identifiers:** KeyWord Plus(R): NANOCRYSTALLINE TIO<sub>2</sub>; CDSE NANOCRYSTALS; GROWTH-KINETICS; TRANSPORT; ADSORPTION; BIOMINERALIZATION; NANORODS; SHAPE

7/8/829 (Item 500 from file: 34)

SciSearch(R) Cited Ref Sci

(c) 2010 The Thomson Corp. All rights reserved.

13326033 **Genuine Article#:** 870BC **Number of References:** 45

**Title:** A Raman spectroscopic study of the adsorption of fibronectin and fibrinogen on titanium dioxide nanoparticles ( ABSTRACT AVAILABLE )

**Publication date:** 20040000

**Journal Subject Category:** CHEMISTRY, PHYSICAL; PHYSICS, ATOMIC, MOLECULAR & CHEMICAL

**Identifiers:** KeyWord Plus(R): BOVINE SERUM-ALBUMIN; PROTEIN SECONDARY STRUCTURE; METAL-OXIDE SURFACES; CRYSTAL-STRUCTURE; CELL

## Appendix A-5. Irrelevant Titles

ATTACHMENT; IMPLANTS; HYDROXYAPATITE; BIOMATERIAL; MECHANISM;  
MOLECULES

7/8/830 (Item 501 from file: 34)

SciSearch(R) Cited Ref Sci

(c) 2010 The Thomson Corp. All rights reserved.

13322191 **Genuine Article#:** 870FH **Number of References:** 18

**Title:** A novel route to the synthesis of mesoporous Titania with full anatase nanocrystalline domains ( ABSTRACT AVAILABLE )

**Publication date:** 20040800

**Journal Subject Category:** MATERIALS SCIENCE, CERAMICS

**Descriptors:** SCIAuthor Keywords: mesoporous titania ; anatase seeds ; hydrothermal self-assembly

**Identifiers:** KeyWord Plus(R): PHOTOCATALYTIC ACTIVITY; SONOCHEMICAL SYNTHESIS; FRAMEWORK; TIO2

7/8/831 (Item 502 from file: 34)

SciSearch(R) Cited Ref Sci

(c) 2010 The Thomson Corp. All rights reserved.

13304066 **Genuine Article#:** 867EK **Number of References:** 25

**Title:** Highly efficient nanocrystalline titania films made from organic/inorganic nanocomposite gels ( ABSTRACT AVAILABLE )

**Publication date:** 20041102

**Journal Subject Category:** CHEMISTRY, APPLIED; CHEMISTRY, PHYSICAL; MATERIALS SCIENCE, MULTIDISCIPLINARY

**Descriptors:** SCIAuthor Keywords: titania ; films ; organic/inorganic nano composite ; gels

**Identifiers:** KeyWord Plus(R): SENSITIZED SOLAR-CELLS; PHOTOCATALYTIC DEGRADATION; TIO2 NANOPARTICLES; MESOPOROUS TITANIA; THIN-FILMS; BASIC-BLUE; DYE; ELECTRODES; PERFORMANCE; LIGHT

7/8/832 (Item 503 from file: 34)

SciSearch(R) Cited Ref Sci

(c) 2010 The Thomson Corp. All rights reserved.

13292375 **Genuine Article#:** 865HA **Number of References:** 35

**Title:** Low-pressure organometallic chemical vapor deposition of indium nitride on titanium dioxide nanoparticles

**Publication date:** 20041018

**Journal Subject Category:** CHEMISTRY, PHYSICAL; PHYSICS, ATOMIC, MOLECULAR & CHEMICAL

**Descriptors:** SCIAuthor Keywords: indium nitride ; photochemistry ; sol-gel processes ; titanium dioxide ; visible absorption

**Identifiers:** KeyWord Plus(R): INN THIN-FILMS; MOLECULAR-BEAM EPITAXY; TIO2 ELECTRODES; SOLAR-CELLS; GROWTH; DYE; GAN; SENSITIZERS; LIGHT

## Appendix A-5. Irrelevant Titles

7/8/833 (Item 504 from file: 34)

SciSearch(R) Cited Ref Sci

(c) 2010 The Thomson Corp. All rights reserved.

13287730 **Genuine Article#:** 866TJ **Number of References:** 11

**Title:** Photoelectrochemical characteristics of nano-titanium dioxide thin films prepared by RF magnetron sputtering ( ABSTRACT AVAILABLE )

**Publication date:** 20041000

**Journal Subject Category:** CHEMISTRY, PHYSICAL

**Descriptors:** SCIAuthor Keywords: RF(radio frequency) magnetron sputtering ; titanium dioxide thin films ; cyclic voltammetry ; hydrophilicity ; photocatalytic

**Identifiers:** KeyWord Plus(R): UV ILLUMINATION; BEHAVIOR

7/8/834 (Item 505 from file: 34)

SciSearch(R) Cited Ref Sci

(c) 2010 The Thomson Corp. All rights reserved.

13280445 **Genuine Article#:** 863YO **Number of References:** 39

**Title:** Surfactant-assisted preparation and characterization of mesoporous titania nanocrystals - Effect of various processing conditions ( ABSTRACT AVAILABLE )

**Publication date:** 20041000

**Journal Subject Category:** MATERIALS SCIENCE, CERAMICS

**Descriptors:** SCIAuthor Keywords: sol-gel ; nanoparticle ; morphology ; transmission electron microscopy (TEM)

**Identifiers:** KeyWord Plus(R): SENSITIZED SOLAR-CELLS; TIO2 THIN-FILMS; MOLECULAR-SIEVES; REVERSE MICELLES; GEL CHEMISTRY; NANOTUBES; CALCINATION; TEMPERATURE; HYDROLYSIS; PARTICLES

7/8/835 (Item 506 from file: 34)

SciSearch(R) Cited Ref Sci

(c) 2010 The Thomson Corp. All rights reserved.

13279902 **Genuine Article#:** 864JR **Number of References:** 19

**Title:** Quantitative study of F center in high-surface-area anatase titania nanoparticles prepared by MOCVD ( ABSTRACT AVAILABLE )

**Publication date:** 20041100

**Journal Subject Category:**

CHEMISTRY, MULTIDISCIPLINARY; PHYSICS, CONDENSED MATTER

**Descriptors:** SCIAuthor Keywords: MOCVD ; nanoparticles ; titania ; EPR ; F center

**Identifiers:** KeyWord Plus(R): TIO2 THIN-FILMS; VISIBLE-LIGHT IRRADIATION; PHOTOCATALYTIC ACTIVITY; HYDROPHILICITY; WATER

7/8/836 (Item 507 from file: 34)

SciSearch(R) Cited Ref Sci

## Appendix A-5. Irrelevant Titles

(c) 2010 The Thomson Corp. All rights reserved.

13242422 **Genuine Article#:** 860LZ **Number of References:** 23

**Title:** Development of self-lubricating titania/diamond nanoparticle composite ( ABSTRACT AVAILABLE )

**Publication date:** 20040900

**Journal Subject Category:** MATERIALS SCIENCE, MULTIDISCIPLINARY; METALLURGY & METALLURGICAL ENGINEERING

**Descriptors:** SCIAuthor Keywords: nanoparticle composites ; diamond ; titania ; self-lubricating

**Identifiers:** KeyWord Plus(R): COATINGS; SURFACE; DIAMOND; FILMS; ALLOY; TIO2

7/8/837 (Item 508 from file: 34)

SciSearch(R) Cited Ref Sci

(c) 2010 The Thomson Corp. All rights reserved.

13222019 **Genuine Article#:** 858TA **Number of References:** 29

**Title:** Photoelectron spectroscopic investigation of nitrogen-doped titania nanoparticles ( ABSTRACT AVAILABLE )

**Publication date:** 20041007

**Journal Subject Category:** CHEMISTRY, PHYSICAL

**Identifiers:** KeyWord Plus(R): PHOTOCATALYTIC ACTIVITY; SEMICONDUCTOR PHOTOCATALYSIS; ION-IMPLANTATION; SINGLE-CRYSTALS; TIO2; NANOCRYSTALS; CHEMISTRY; POWDERS; WATER

7/8/838 (Item 509 from file: 34)

SciSearch(R) Cited Ref Sci

(c) 2010 The Thomson Corp. All rights reserved.

13221313 **Genuine Article#:** 858TE **Number of References:** 33

**Title:** Photoelectrochemical properties of titania nanotubes ( ABSTRACT AVAILABLE )

**Publication date:** 20041000

**Journal Subject Category:** MATERIALS SCIENCE, MULTIDISCIPLINARY

**Identifiers:** KeyWord Plus(R): TIO2 FILMS; ELECTRODES; WATER; NANOPARTICLES; PALLADIUM; TRANSPORT; OXIDATION; ARRAYS; CELLS

7/8/839 (Item 510 from file: 34)

SciSearch(R) Cited Ref Sci

(c) 2010 The Thomson Corp. All rights reserved.

13212723 **Genuine Article#:** 858CR **Number of References:** 14

**Title:** Nanocarving of titania (TiO<sub>2</sub>): a novel approach for fabricating chemical sensing platform ( ABSTRACT AVAILABLE )

**Publication date:** 20040000

**Journal Subject Category:** MATERIALS SCIENCE, CERAMICS

**Descriptors:** SCIAuthor Keywords: TiO<sub>2</sub> ; sensors ; nanofiber ; nanomaterials

## Appendix A-5. Irrelevant Titles

**Identifiers:** KeyWord Plus(R): CARBON-MONOXIDE; GAS SENSORS; CRYSTALS; SIZE

7/8/840 (Item 511 from file: 34)

SciSearch(R) Cited Ref Sci

(c) 2010 The Thomson Corp. All rights reserved.

13181852 **Genuine Article#:** 855RI **Number of References:** 14

**Title:** Preparation and characterization of nanocrystalline transition metal-loaded sulfated titania through sol-gel method ( ABSTRACT AVAILABLE )

**Publication date:** 20041000

**Journal Subject Category:** MATERIALS SCIENCE, MULTIDISCIPLINARY; PHYSICS, APPLIED

**Descriptors:** SCIAuthor Keywords: sol-gel **processing** ; nano materials ; titania ; sulfated titania

**Identifiers:** KeyWord Plus(R): CATALYSTS; OXIDES

7/8/841 (Item 512 from file: 34)

SciSearch(R) Cited Ref Sci

(c) 2010 The Thomson Corp. All rights reserved.

13176030 **Genuine Article#:** 855IH **Number of References:** 12

**Title:** Phase composition of nanocrystalline titania synthesized under hydrothermal conditions from different titanil compounds ( ABSTRACT AVAILABLE )

**Publication date:** 20040800

**Journal Subject Category:** MATERIALS SCIENCE, MULTIDISCIPLINARY

**Identifiers:** KeyWord Plus(R): TIO2 POWDERS; ANATASE; HYDROLYSIS; TI(SO4)(2)

7/8/842 (Item 513 from file: 34)

SciSearch(R) Cited Ref Sci

(c) 2010 The Thomson Corp. All rights reserved.

13143403 **Genuine Article#:** 852RH **Number of References:** 16

**Title:** Dynamics and mechanistic features in the photocatalyzed oxidation of disulfonated anionic surfactants on the surface of UV-irradiated titania nanoparticles ( ABSTRACT AVAILABLE )

**Publication date:** 20040000

**Journal Subject Category:** CHEMISTRY, MULTIDISCIPLINARY

**Identifiers:** KeyWord Plus(R): SODIUM DODECYLBENZENE SULFONATE; PHOTODEGRADATION; DEGRADATION; DEPENDENCE

7/8/843 (Item 514 from file: 34)

SciSearch(R) Cited Ref Sci

(c) 2010 The Thomson Corp. All rights reserved.

13088942 **Genuine Article#:** 848JQ **Number of References:** 33

## Appendix A-5. Irrelevant Titles

**Title:** Microstructure characterization of titanium dioxide nanodispersions and thin films for dye-sensitized solar cell devices ( ABSTRACT AVAILABLE )

**Publication date:** 20041100

**Journal Subject Category:** MATERIALS SCIENCE, MULTIDISCIPLINARY; PHYSICS, APPLIED

**Identifiers:** KeyWord Plus(R): MANUFACTURING NANOSTRUCTURED ELECTRODES; NANOCRYSTALLINE TIO<sub>2</sub>; PHASE-TRANSFORMATION; MICROSCOPY; PHOTOVOLTAICS; HYDROLYSIS; PARTICLES; POWDERS

7/8/844 (Item 515 from file: 34)

SciSearch(R) Cited Ref Sci

(c) 2010 The Thomson Corp. All rights reserved.

13074349 **Genuine Article#:** BAO19 **Number of References:** 6

**Title:** Preparation and microstructural development of nanocrystalline titania and alumina ( ABSTRACT AVAILABLE )

**Publication date:** 20040000

**Journal Subject Category:** MATERIALS SCIENCE, CERAMICS; MATERIALS SCIENCE, COMPOSITES

**Descriptors:** SCIAuthor Keywords: titania ; alumina ; nanocrystalline ; sol-gel ; grain size

**Identifiers:** KeyWord Plus(R): SUPERPLASTICITY; TEMPERATURE

7/8/845 (Item 516 from file: 34)

SciSearch(R) Cited Ref Sci

(c) 2010 The Thomson Corp. All rights reserved.

13073790 **Genuine Article#:** BAO19 **Number of References:** 5

**Title:** Effects of positive ionic radius on the phase transition of titania nano powders from aqueous TiOCl<sub>2</sub> solutions ( ABSTRACT AVAILABLE )

**Publication date:** 20040000

**Journal Subject Category:** MATERIALS SCIENCE, CERAMICS; MATERIALS SCIENCE, COMPOSITES

**Descriptors:** SCIAuthor Keywords: TiO<sub>2</sub> powder ; positive ionic radius ; phase transition ; capillary forces ; metal-chlorides

**Identifiers:** KeyWord Plus(R): TIO<sub>2</sub> ULTRAFINE POWDERS; HOMOGENEOUS PRECIPITATION; RUTILE PHASE; TEMPERATURE

7/8/846 (Item 517 from file: 34)

SciSearch(R) Cited Ref Sci

(c) 2010 The Thomson Corp. All rights reserved.

13068888 **Genuine Article#:** 845NP **Number of References:** 40

**Title:** Studies on photophysical and electrochemical properties of synthesized hydroxy perylenediimides in nanostructured titania thin films ( ABSTRACT AVAILABLE )

**Publication date:** 20040827

**Journal Subject Category:** MATERIALS SCIENCE, MULTIDISCIPLINARY; PHYSICS, CONDENSED MATTER; POLYMER SCIENCE

## Appendix A-5. Irrelevant Titles

**Descriptors:** SCIAuthor Keywords: perylenediimide ; solubility ; photophysical property ; sol-gel thin film ; nanostructured TiO<sub>2</sub> ; dye sensitized solar cells

**Identifiers:** KeyWord Plus(R): NANOCRYSTALLINE TIO<sub>2</sub>; DYE SENSITIZATION; ENERGY-TRANSFER; ELECTRON-TRANSFER; SOLAR-CELLS; DIIMIDE; PHOTOSENSITIZATION; DERIVATIVES; STANDARD; PROBES

7/8/847 (Item 518 from file: 34)

SciSearch(R) Cited Ref Sci

(c) 2010 The Thomson Corp. All rights reserved.

13067464 **Genuine Article#:** 845TE **Number of References:** 9

**Title:** Controlled-hydrolytic synthesis of nanosized titania and evaluation of photodegradation of methyl orange ( ABSTRACT AVAILABLE )

**Publication date:** 20031200

**Journal Subject Category:** MATERIALS SCIENCE, MULTIDISCIPLINARY; METALLURGY & METALLURGICAL ENGINEERING

**Descriptors:** SCIAuthor Keywords: TiO<sub>2</sub> ; hydrolysis ; photocatalysis ; methyl orange

7/8/848 (Item 519 from file: 34)

SciSearch(R) Cited Ref Sci

(c) 2010 The Thomson Corp. All rights reserved.

13062063 **Genuine Article#:** 845BD **Number of References:** 14

**Title:** Electrochemical performance of granulated titania nanoparticles ( ABSTRACT AVAILABLE )

**Publication date:** 20040812

**Journal Subject Category:** ELECTROCHEMISTRY; ENERGY & FUELS

**Descriptors:** SCIAuthor Keywords: sol-gel ; nanocrystalline titania ; electrochemical lithium insertion ; granulation ; structured electrode

**Identifiers:** KeyWord Plus(R): LI INSERTION; TIO<sub>2</sub>; ELECTRODES; ANATASE

7/8/849 (Item 520 from file: 34)

SciSearch(R) Cited Ref Sci

(c) 2010 The Thomson Corp. All rights reserved.

12998676 **Genuine Article#:** 840MY **Number of References:** 98

**Title:** Titania nanoparticles prepared with pulsed laser ablation of rutile single crystals in water ( ABSTRACT AVAILABLE )

**Publication date:** 20040729

**Journal Subject Category:** CHEMISTRY, PHYSICAL

**Identifiers:** KeyWord Plus(R): RAY PHOTOELECTRON-SPECTROSCOPY; PT/TIO<sub>2</sub> NANOCOMPOSITE FILMS; THIN-FILMS; METATHESIS REACTION; OPTICAL-PROPERTIES; OLEFIN METATHESIS; ROOM-TEMPERATURE; MOLYBDENUM OXIDE; AQUEOUS-SOLUTION; TIO<sub>2</sub> PARTICLES

## Appendix A-5. Irrelevant Titles

7/8/850 (Item 521 from file: 34)

SciSearch(R) Cited Ref Sci

(c) 2010 The Thomson Corp. All rights reserved.

12993196 **Genuine Article#:** 840QU **Number of References:** 34

**Title:** Titanium dioxide nanoribers prepared by using electrospinning method ( ABSTRACT AVAILABLE )

**Publication date:** 20040600

**Journal Subject Category:** MATERIALS SCIENCE, TEXTILES; POLYMER SCIENCE

**Descriptors:** SCIAuthor Keywords: hybrid nanofibers ; titanium isopropoxide/poly(vinyl acetate) ; titanium dioxide ; calcination

**Identifiers:** KeyWord Plus(R): TIO2-II THIN-FILMS; PHASE-TRANSFORMATION; OPTICAL-PROPERTIES; POWDERS; POLYMERIZATION; DEPOSITION; CHEMISTRY; FIBERS; GROWTH; RAMAN

7/8/851 (Item 522 from file: 34)

SciSearch(R) Cited Ref Sci

(c) 2010 The Thomson Corp. All rights reserved.

12990151 **Genuine Article#:** 840ZP **Number of References:** 10

**Title:** Towards flexible inorganic "mesomaterials": one-pot low temperature synthesis of mesostructured nanocrystalline titania ( ABSTRACT AVAILABLE )

**Publication date:** 20040707

**Journal Subject Category:** CHEMISTRY, MULTIDISCIPLINARY

**Identifiers:** KeyWord Plus(R): ANATASE; FILMS

7/8/852 (Item 523 from file: 34)

SciSearch(R) Cited Ref Sci

(c) 2010 The Thomson Corp. All rights reserved.

12940583 **Genuine Article#:** 833NY **Number of References:** 11

**Title:** Synthesis of nanotube from a layered H<sub>2</sub>Ti<sub>4</sub>O<sub>9</sub> center dot H<sub>2</sub>O in a hydrothermal treatment using various titania sources ( ABSTRACT AVAILABLE )

**Publication date:** 20040701

**Journal Subject Category:** MATERIALS SCIENCE, MULTIDISCIPLINARY

**Identifiers:** KeyWord Plus(R): OXIDE

7/8/853 (Item 524 from file: 34)

SciSearch(R) Cited Ref Sci

(c) 2010 The Thomson Corp. All rights reserved.

12914253 **Genuine Article#:** 833DI **Number of References:** 22

**Title:** A study on the growth and structure of titania nanotubes ( ABSTRACT AVAILABLE )

**Publication date:** 20040200

## Appendix A-5. Irrelevant Titles

**Journal Subject Category:** MATERIALS SCIENCE, MULTIDISCIPLINARY

**Identifiers:** KeyWord Plus(R): OXIDE NANOTUBE; TIO<sub>2</sub> NANOTUBES; ARRAYS; SIZE

7/8/854 (Item 525 from file: 34)

SciSearch(R) Cited Ref Sci

(c) 2010 The Thomson Corp. All rights reserved.

12914108 **Genuine Article#:** 833DN **Number of References:** 34

**Title:** Growth and characterization of gallium nitride nanowires produced on different sol-gel derived catalyst dispersed in titania and polyvinyl alcohol matrix ( ABSTRACT AVAILABLE )

**Publication date:** 20040600

**Journal Subject Category:** MATERIALS SCIENCE, MULTIDISCIPLINARY

**Identifiers:** KeyWord Plus(R): ALUMINUM NITRIDE; EPITAXIAL-GROWTH; LASER-ABLATION; HEXAGONAL GAN; NANORODS; FILMS; RAMAN; DEPOSITION; MECHANISM

7/8/855 (Item 526 from file: 34)

SciSearch(R) Cited Ref Sci

(c) 2010 The Thomson Corp. All rights reserved.

12904991 **Genuine Article#:** 832FJ **Number of References:** 28

**Title:** Preparation and thermal stability of gold nanoparticles in silk-templated porous filaments of titania and zirconia ( ABSTRACT AVAILABLE )

**Publication date:** 20040629

**Journal Subject Category:** CHEMISTRY, PHYSICAL; MATERIALS SCIENCE, MULTIDISCIPLINARY

**Identifiers:** KeyWord Plus(R): NOBLE-METAL NANOPARTICLES; ULTRATHIN TIO<sub>2</sub>-GEL FILMS; IN-SITU SYNTHESIS; SPIDER SILK; FABRICATION; NANOARCHITECTURES; COMPOSITES; PARTICLES; FIBERS; SILVER

7/8/856 (Item 527 from file: 34)

SciSearch(R) Cited Ref Sci

(c) 2010 The Thomson Corp. All rights reserved.

12898929 **Genuine Article#:** 830VX **Number of References:** 24

**Title:** Photocatalytic oxidation on nanostructured chalcogenide modified titanium dioxide ( ABSTRACT AVAILABLE )

**Publication date:** 20040700

**Journal Subject Category:** ENERGY & FUELS; MATERIALS SCIENCE, MULTIDISCIPLINARY

**Descriptors:** SCIAuthor Keywords: RuxSex ; nanoparticle ; anatase (TiO<sub>2</sub>) ; photocatalysis

**Identifiers:** KeyWord Plus(R): TIO<sub>2</sub> FILMS; KINETIC APPROACH; ELECTRODES; OXYGEN; NANOPARTICLES; REDUCTION; ELECTROREDUCTION; PHOTOCURRENTS; TRANSPORT; ALKALINE

## Appendix A-5. Irrelevant Titles

7/8/857 (Item 528 from file: 34)

SciSearch(R) Cited Ref Sci

(c) 2010 The Thomson Corp. All rights reserved.

12887128 **Genuine Article#:** 830PW **Number of References:** 15

**Title:** Production of titania nanoparticles by using a new microreactor assembled with same axle dual pipe ( ABSTRACT AVAILABLE )

**Publication date:** 20040801

**Journal Subject Category:** ENGINEERING, CHEMICAL

**Descriptors:** SCIAuthor Keywords: titania nanoparticles ; microreactor ; axle dual pipe

**Identifiers:** KeyWord Plus(R): COLLOIDAL METAL; NANOCRYSTALS; PARTICLES; DEVICES

7/8/858 (Item 529 from file: 34)

SciSearch(R) Cited Ref Sci

(c) 2010 The Thomson Corp. All rights reserved.

12884034 **Genuine Article#:** BAF50 **Number of References:** 6

**Title:** Active nanocrystals in erbium-doped silica-titania sol-gel films ( ABSTRACT AVAILABLE )

**Publication date:** 20040000

**Journal Subject Category:** MATERIALS SCIENCE, MULTIDISCIPLINARY

**Descriptors:** SCIAuthor Keywords: erbium ; nanocrystals ; EXAFS ; sol-gel films

7/8/859 (Item 530 from file: 34)

SciSearch(R) Cited Ref Sci

(c) 2010 The Thomson Corp. All rights reserved.

12858119 **Genuine Article#:** 826QN **Number of References:** 30

**Title:** Shape-controlled synthesis of nanocrystalline titania at low temperature ( ABSTRACT AVAILABLE )

**Publication date:** 20040600

**Journal Subject Category:** PHYSICS, CONDENSED MATTER

**Descriptors:** SCIAuthor Keywords: titania ; titanium tetrachloride ; hydrolysis ; transmission electron microscopy ; X-ray diffraction

**Identifiers:** KeyWord Plus(R): NANOSIZE RUTILE; ORIENTED ATTACHMENT; ANATASE PARTICLES; CRYSTALLINE TIO<sub>2</sub>; ROOM-TEMPERATURE; GROWTH; PHOTOCATALYSIS; MEMBRANES; SURFACES; INSIGHTS

7/8/860 (Item 531 from file: 34)

SciSearch(R) Cited Ref Sci

(c) 2010 The Thomson Corp. All rights reserved.

12849140 **Genuine Article#:** 826FR **Number of References:** 31

**Title:** Photoelectrocatalytic production of active chlorine on nanocrystalline titanium dioxide thin-film electrodes ( ABSTRACT AVAILABLE )

**Publication date:** 20040601

## Appendix A-5. Irrelevant Titles

**Journal Subject Category:** ENGINEERING, ENVIRONMENTAL; ENVIRONMENTAL SCIENCES

**Identifiers:** KeyWord Plus(R): ELECTROGENERATED HYPOCHLORITE ION; FORMIC-ACID; ANODIC EVOLUTION; DEGRADATION; DISINFECTION; ELECTROCATALYSIS; FORMALDEHYDE; MECHANISM; OXIDATION; OXYGEN

7/8/861 (Item 532 from file: 34)

SciSearch(R) Cited Ref Sci

(c) 2010 The Thomson Corp. All rights reserved.

12837682 **Genuine Article#:** 825JB **Number of References:** 26

**Title:** Synthesis and characterization of titania-coated silver nanoparticles ( ABSTRACT AVAILABLE )

**Publication date:** 20040300

**Journal Subject Category:** CHEMISTRY, MULTIDISCIPLINARY; MATERIALS SCIENCE, MULTIDISCIPLINARY

**Descriptors:** SCIAuthor Keywords: titania ; silver ; nanoparticles ; plasmon resonance ; sol-gel ; hydrothermal

**Identifiers:** KeyWord Plus(R): SEMICONDUCTOR PHOTOCATALYSIS; METAL NANOPARTICLES; AMORPHOUS TITANIA; PARTICLES; ANATASE; CELLS

7/8/862 (Item 533 from file: 34)

SciSearch(R) Cited Ref Sci

(c) 2010 The Thomson Corp. All rights reserved.

12837669 **Genuine Article#:** 825JB **Number of References:** 28

**Title:** Nanostructured titania powders by hydrothermal processing and spray drying ( ABSTRACT AVAILABLE )

**Publication date:** 20040300

**Journal Subject Category:** CHEMISTRY, MULTIDISCIPLINARY; MATERIALS SCIENCE, MULTIDISCIPLINARY

**Descriptors:** SCIAuthor Keywords: spray drying ; titania ; nanoparticle ; hydrothermal process ; sol-gel ; nanostructure ; pore structure ; phase composition

**Identifiers:** KeyWord Plus(R): RUTILE TRANSFORMATION; AMORPHOUS TITANIA; CERAMIC POWDERS; ANATASE; PHASE; MEMBRANES; TEMPERATURE; HYDROLYSIS; CALCINATION; PARAMETERS

7/8/863 (Item 534 from file: 34)

SciSearch(R) Cited Ref Sci

(c) 2010 The Thomson Corp. All rights reserved.

12801764 **Genuine Article#:** 820BR **Number of References:** 17

**Title:** Electro-rheological behavior of suspension composed of titanium dioxide nanoparticles ( ABSTRACT AVAILABLE )

**Publication date:** 20040501

**Journal Subject Category:** ENGINEERING, ELECTRICAL & ELECTRONIC; INSTRUMENTS & INSTRUMENTATION

## Appendix A-5. Irrelevant Titles

**Descriptors:** SCIAuthor Keywords: nano-particles ; suspension ; functional fluids ; electro-rheology ; narrow gap

**Identifiers:** KeyWord Plus(R): CONDUCTIVITY; ELECTRODES; POLYMER

7/8/864 (Item 535 from file: 34)

SciSearch(R) Cited Ref Sci

(c) 2010 The Thomson Corp. All rights reserved.

12774169 **Genuine Article#:** 818TW **Number of References:** 48

**Title:** Electronic band structure of titania semiconductor nanosheets revealed by electrochemical and photoelectrochemical studies ( ABSTRACT AVAILABLE )

**Publication date:** 20040512

**Journal Subject Category:** CHEMISTRY, MULTIDISCIPLINARY

**Identifiers:** KeyWord Plus(R): POLYCRYSTALLINE TIO<sub>2</sub> ELECTRODES; SPECTROSCOPIC DETERMINATION; OPTICAL-PROPERTIES; FILMS; PHOTOCATALYSIS; ANATASE; SYSTEMS; DIOXIDE; CRYSTALLITES; IRRADIATION

7/8/865 (Item 536 from file: 34)

SciSearch(R) Cited Ref Sci

(c) 2010 The Thomson Corp. All rights reserved.

12707212 **Genuine Article#:** 813VW **Number of References:** 22

**Title:** Hydrothermal synthesis of nanocrystalline and mesoporous titania from aqueous complex titanyl oxalate acid solutions ( ABSTRACT AVAILABLE )

**Publication date:** 20040421

**Journal Subject Category:** PHYSICS, ATOMIC, MOLECULAR & CHEMICAL

**Identifiers:** KeyWord Plus(R): ANATASE; RUTILE; PHOTOCATALYSIS; POWDERS

7/8/866 (Item 537 from file: 34)

SciSearch(R) Cited Ref Sci

(c) 2010 The Thomson Corp. All rights reserved.

12702186 **Genuine Article#:** 810LW **Number of References:** 8

**Title:** A novel synthetic method for nanosized crystalline titania for use in the decomposition of dyes ( ABSTRACT AVAILABLE )

**Publication date:** 20040000

**Journal Subject Category:** ENGINEERING, ENVIRONMENTAL; ENVIRONMENTAL SCIENCES; WATER RESOURCES

**Descriptors:** SCIAuthor Keywords: dye decomposition ; hydrothermal ; nanoparticle ; photocatalyst ; TiO<sub>2</sub> ; titania

**Identifiers:** KeyWord Plus(R): TIO<sub>2</sub>

7/8/867 (Item 538 from file: 34)

SciSearch(R) Cited Ref Sci

## Appendix A-5. Irrelevant Titles

(c) 2010 The Thomson Corp. All rights reserved.

12694880 **Genuine Article#:** 810UC **Number of References:** 13

**Title:** Synthesis of visible-light-active nanosize rutile titania photocatalyst by low temperature dissolution-precipitation process ( ABSTRACT AVAILABLE )

**Publication date:** 20040415

**Journal Subject Category:** CHEMISTRY, PHYSICAL

**Descriptors:** SCIAuthor Keywords: visible-light-active photocatalyst ; nanosize rutile titania ; low temperature dissolution-precipitation **process** ; hydrogen evolution ; nitrogen monoxide destruction

**Identifiers:** KeyWord Plus(R): LIQUID-MEDIA; ANATASE; TIO2

7/8/868 (Item 539 from file: 34)

SciSearch(R) Cited Ref Sci

(c) 2010 The Thomson Corp. All rights reserved.

12678646 **Genuine Article#:** 809KO **Number of References:** 38

**Title:** Low-temperature synthesis and microstructural control of titania nano-particles ( ABSTRACT AVAILABLE )

**Publication date:** 20040400

**Journal Subject Category:** CHEMISTRY, INORGANIC & NUCLEAR; CHEMISTRY, PHYSICAL

**Descriptors:** SCIAuthor Keywords: titania ; nanoparticles ; microstructure control ; sol-gel

**Identifiers:** KeyWord Plus(R): NANOCRYSTALLINE ANATASE; TIO2

PHOTOCATALYSTS; METAL-OXIDES; SOL; GROWTH; ULTRAFINE; INSIGHTS; KINETICS; POWDERS; RUTILE

7/8/869 (Item 540 from file: 34)

SciSearch(R) Cited Ref Sci

(c) 2010 The Thomson Corp. All rights reserved.

12671563 **Genuine Article#:** 809KA **Number of References:** 44

**Title:** Tailoring the surface and solubility properties of nanocrystalline titania by a nonaqueous in situ functionalization process ( ABSTRACT AVAILABLE )

**Publication date:** 20040406

**Journal Subject Category:** CHEMISTRY, PHYSICAL; MATERIALS SCIENCE, MULTIDISCIPLINARY

**Identifiers:** KeyWord Plus(R): VERSATILE REACTION SYSTEM; TIO2

NANOPARTICLES; SIZE QUANTIZATION; BUILDING-BLOCKS; BENZYL ALCOHOL; PARTICLE-SIZE; GAS-SENSORS; THIN-FILMS; ANATASE; NANOCOMPOSITES

7/8/870 (Item 541 from file: 34)

SciSearch(R) Cited Ref Sci

(c) 2010 The Thomson Corp. All rights reserved.

## Appendix A-5. Irrelevant Titles

12550513 **Genuine Article#:** 779RX **Number of References:** 6

**Title:** Study on solvent resistance and thermal resistance of polyimide/ titania nanocomposites ( ABSTRACT AVAILABLE )

**Publication date:** 20030400

**Journal Subject Category:** POLYMER SCIENCE

**Descriptors:** SCIAuthor Keywords: polyimide/TiO<sub>2</sub> sol-gel ; nanocomposite ; solvent resistance ; thermal properties

7/8/871 (Item 542 from file: 34)

SciSearch(R) Cited Ref Sci

(c) 2010 The Thomson Corp. All rights reserved.

12497689 **Genuine Article#:** 751JG **Number of References:** 0

**Title:** Synthesis and characterization of nanosized anatase and rutile titania with narrow size distribution in sol-gel process.

**Publication date:** 20030900

**Journal Subject Category:** CHEMISTRY, MULTIDISCIPLINARY

7/8/872 (Item 543 from file: 34)

SciSearch(R) Cited Ref Sci

(c) 2010 The Thomson Corp. All rights reserved.

12366377 **Genuine Article#:** 760GG **Number of References:** 24

**Title:** Behavior of bromide in the photoelectrocatalytic process and bromine generation using nanoporous titanium dioxide thin-film electrodes ( ABSTRACT AVAILABLE )

**Publication date:** 20040200

**Journal Subject Category:** ENVIRONMENTAL SCIENCES

**Descriptors:** SCIAuthor Keywords: bromine generation ; titanium dioxide ; electrodes ; photoelectrocatalytic

**Identifiers:** KeyWord Plus(R): ULTRAVIOLET WAVELENGTHS; AQUEOUS CHLORINE; DRINKING-WATER; HUMIC-ACID; DEGRADATION; PHOTOLYSIS; PRODUCTS; DISINFECTION; SUNLIGHT; KINETICS

7/8/873 (Item 544 from file: 34)

SciSearch(R) Cited Ref Sci

(c) 2010 The Thomson Corp. All rights reserved.

12342152 **Genuine Article#:** 753MU **Number of References:** 39

**Title:** Synthesis and photocatalytic properties of quantum confined titanium dioxide nanoparticle ( ABSTRACT AVAILABLE )

**Publication date:** 20040200

**Journal Subject Category:** MATERIALS SCIENCE, MULTIDISCIPLINARY; METALLURGY & METALLURGICAL ENGINEERING

**Descriptors:** SCIAuthor Keywords: chemical synthesis ; catalysis ; oxides ; nanocrystalline

**Identifiers:** KeyWord Plus(R): RUTILE PHASE-TRANSITION; ANATASE-TO-RUTILE; TIO<sub>2</sub> SUSPENSIONS; OXIDATION; TRANSFORMATION; CYCLOHEXANE;

## Appendix A-5. Irrelevant Titles

MECHANISM; SURFACES; KINETICS; OXIDE

7/8/874 (Item 545 from file: 34)

SciSearch(R) Cited Ref Sci

(c) 2010 The Thomson Corp. All rights reserved.

12195207 **Genuine Article#:** 739LT **Number of References:** 14

**Title:** Hydrothermal processing of nanocrystalline anatase films from tetraethylammonium hydroxide peptized titania sols ( ABSTRACT AVAILABLE )

**Publication date:** 20040000

**Journal Subject Category:** MATERIALS SCIENCE, CERAMICS

**Descriptors:** SCIAuthor Keywords: hydrothermal methods ; peptization ; anatase ; TiO<sub>2</sub> ; films

**Identifiers:** KeyWord Plus(R): THIN-FILMS; MICROSPHERES; POWDERS

7/8/875 (Item 546 from file: 34)

SciSearch(R) Cited Ref Sci

(c) 2010 The Thomson Corp. All rights reserved.

12194401 **Genuine Article#:** 739LB **Number of References:** 16

**Title:** Nanostructured polysilane-titania hybrids and their application to porous titania thin films ( ABSTRACT AVAILABLE )

**Publication date:** 20031115

**Journal Subject Category:** CHEMISTRY, INORGANIC & NUCLEAR; CHEMISTRY, ORGANIC

**Descriptors:** SCIAuthor Keywords: polysilane ; titanium oxide ; organic-inorganic hybrid ; nanostructures ; atomic force microscope

**Identifiers:** KeyWord Plus(R): METHACRYLATE COPOLYMERS; OPTICAL-PROPERTIES; FABRICATION; SEGMENTS

7/8/876 (Item 547 from file: 34)

SciSearch(R) Cited Ref Sci

(c) 2010 The Thomson Corp. All rights reserved.

12194068 **Genuine Article#:** 739ZX **Number of References:** 36

**Title:** Fabrication of tapered, conical-shaped titania nanotubes ( ABSTRACT AVAILABLE )

**Publication date:** 20031100

**Journal Subject Category:** MATERIALS SCIENCE, MULTIDISCIPLINARY

**Identifiers:** KeyWord Plus(R): ANODIC AL<sub>2</sub>O<sub>3</sub> FILMS; NANOPOROUS ALUMINA FILMS; HEXAGONAL PORE ARRAYS; OXIDE-FILMS; ELECTROCHEMICAL-BEHAVIOR; TIO<sub>2</sub> NANOTUBES; TA6V ALLOY; GROWTH; TEMPERATURE; OXIDATION

7/8/877 (Item 548 from file: 34)

## Appendix A-5. Irrelevant Titles

SciSearch(R) Cited Ref Sci

(c) 2010 The Thomson Corp. All rights reserved.

12167746 **Genuine Article#:** 736KB **Number of References:** 15

**Title:** Formation of zinc oxide-titanium dioxide composite nanoparticles in supercritical water ( ABSTRACT AVAILABLE )

**Publication date:** 20031029

**Journal Subject Category:** ENGINEERING, CHEMICAL

**Identifiers:** KeyWord Plus(R): HYDROTHERMAL SYNTHESIS; SPRAY PYROLYSIS; FINE PARTICLES

7/8/878 (Item 549 from file: 34)

SciSearch(R) Cited Ref Sci

(c) 2010 The Thomson Corp. All rights reserved.

12146590 **Genuine Article#:** 734HY **Number of References:** 22

**Title:** Controlled iron-doping of macrotextured nanocrystalline titania ( ABSTRACT AVAILABLE )

**Publication date:** 20031021

**Journal Subject Category:** CHEMISTRY, PHYSICAL; MATERIALS SCIENCE, MULTIDISCIPLINARY

**Identifiers:** KeyWord Plus(R): RAMAN-SPECTROSCOPY; TIO<sub>2</sub>; PHOTOCATALYSIS; ANATASE; RUTILE; GLASS

7/8/879 (Item 550 from file: 34)

SciSearch(R) Cited Ref Sci

(c) 2010 The Thomson Corp. All rights reserved.

12131475 **Genuine Article#:** 732UB **Number of References:** 30

**Title:** Liquid phase processing and thin film deposition of titania nanocrystallites for photocatalytic applications on thermally sensitive substrates ( ABSTRACT AVAILABLE )

**Publication date:** 20031001

**Journal Subject Category:** MATERIALS SCIENCE, MULTIDISCIPLINARY

**Identifiers:** KeyWord Plus(R): SOL-GEL PREPARATION; NANOSTRUCTURED TITANIA; ANATASE TIO<sub>2</sub>; TRANSFORMATION; DENSIFICATION; GLASS; FUNDAMENTALS; PEPTIZATION; LAYERS

7/8/880 (Item 551 from file: 34)

SciSearch(R) Cited Ref Sci

(c) 2010 The Thomson Corp. All rights reserved.

12020508 **Genuine Article#:** 722HG **Number of References:** 16

**Title:** Study on adsorption behavior of rare earth complexes on nanometer -size titanium dioxide with ICP-AES ( ABSTRACT AVAILABLE )

**Publication date:** 20030800

**Journal Subject Category:** CHEMISTRY, APPLIED

**Descriptors:** SCIAuthor Keywords: inorganic metallic materials ; nanometer TiO<sub>2</sub> ; Eu

## Appendix A-5. Irrelevant Titles

complexes ; adsorption ; speciation ; rare earths

**Identifiers:** KeyWord Plus(R): TRACE-METALS; SPECIATION; ELEMENTS

7/8/881 (Item 552 from file: 34)

SciSearch(R) Cited Ref Sci

(c) 2010 The Thomson Corp. All rights reserved.

12011259 **Genuine Article#:** 719TT **Number of References:** 32

**Title:** Oversized titania nanosheet crystallites derived from flux-grown layered titanate single crystals ( ABSTRACT AVAILABLE )

**Publication date:** 20030909

**Journal Subject Category:** CHEMISTRY, PHYSICAL; MATERIALS SCIENCE, MULTIDISCIPLINARY

**Identifiers:** KeyWord Plus(R): REASSEMBLING PROCESS; CHEMICAL PROCESS; MANGANESE OXIDE; EXFOLIATION; PEROVSKITE; INTERCALATION; DELAMINATION; FILMS; FABRICATION; DISPERSIONS

7/8/882 (Item 553 from file: 34)

SciSearch(R) Cited Ref Sci

(c) 2010 The Thomson Corp. All rights reserved.

12005436 **Genuine Article#:** 717KP **Number of References:** 16

**Title:** Photocarrier generation at nano-interfaces in organic polysilane- titania matrix hybrid thin films ( ABSTRACT AVAILABLE )

**Publication date:** 20030822

**Journal Subject Category:** MATERIALS SCIENCE, MULTIDISCIPLINARY; PHYSICS, APPLIED; PHYSICS, CONDENSED MATTER

**Descriptors:** SCIAuthor Keywords: polymers ; titanium oxide ; luminescence ; photoconductivity

**Identifiers:** KeyWord Plus(R): REFRACTIVE-INDEX; METHACRYLATE COPOLYMERS; OPTICAL-PROPERTIES; FABRICATION; TRANSPORT; SEGMENTS

7/8/883 (Item 554 from file: 34)

SciSearch(R) Cited Ref Sci

(c) 2010 The Thomson Corp. All rights reserved.

11956020 **Genuine Article#:** 713TJ **Number of References:** 30

**Title:** Micro/nano-structural properties of imprinted macroporous titania and zirconia ( ABSTRACT AVAILABLE )

**Publication date:** 20030000

**Journal Subject Category:** CHEMISTRY, PHYSICAL; MATERIALS SCIENCE, MULTIDISCIPLINARY

**Identifiers:** KeyWord Plus(R): SOL-GEL PROCESS; INVERSE OPALS; METAL-OXIDES; POLY; COLLOIDAL SPHERES; INORGANIC OXIDES; HOLLOW SPHERES; POLYMER LATEX; POROUS SILICA; TIO2

## Appendix A-5. Irrelevant Titles

7/8/884 (Item 555 from file: 34)

SciSearch(R) Cited Ref Sci

(c) 2010 The Thomson Corp. All rights reserved.

11956012 **Genuine Article#:** 713TJ **Number of References:** 39

**Title:** Europium doped nanocrystalline titanium dioxide: preparation, phase transformation and photocatalytic properties ( ABSTRACT AVAILABLE )

**Publication date:** 20030000

**Journal Subject Category:** CHEMISTRY, PHYSICAL; MATERIALS SCIENCE, MULTIDISCIPLINARY

**Identifiers:** KeyWord Plus(R): SELECTIVE CATALYTIC REDUCTION; QUANTUM-SIZED TIO<sub>2</sub>; METAL-ION DOPANTS; RUTILE; REACTIVITY; PARTICLES; MECHANISM; LANTHANA; AMMONIA; METHANE

7/8/885 (Item 556 from file: 34)

SciSearch(R) Cited Ref Sci

(c) 2010 The Thomson Corp. All rights reserved.

11934494 **Genuine Article#:** 709YT **Number of References:** 98

**Title:** Controlled formation of highly organized mesoporous titania thin films: From mesostructured hybrids to mesoporous nanoanatase TiO<sub>2</sub> ( ABSTRACT AVAILABLE )

**Publication date:** 20030813

**Journal Subject Category:** CHEMISTRY, MULTIDISCIPLINARY

**Identifiers:** KeyWord Plus(R): LYOTROPIC LIQUID-CRYSTALLINE; AMPHIPHILIC BLOCK-COPOLYMERS; X-RAY-SCATTERING; MOLECULAR-SIEVES; SILICA STRUCTURES; CHEMICAL MODIFICATION; TRIBLOCK COPOLYMERS; THERMAL-STABILITY; AQUEOUS-SOLUTIONS; METAL ALKOXIDES

7/8/886 (Item 557 from file: 34)

SciSearch(R) Cited Ref Sci

(c) 2010 The Thomson Corp. All rights reserved.

11927596 **Genuine Article#:** 710PC **Number of References:** 24

**Title:** Titania from nanoclusters to nanowires and nanoforks ( ABSTRACT AVAILABLE )

**Publication date:** 20030600

**Journal Subject Category:** PHYSICS, ATOMIC, MOLECULAR & CHEMICAL

**Identifiers:** KeyWord Plus(R): TIO<sub>2</sub>; NANORODS; SENSOR

7/8/887 (Item 558 from file: 34)

SciSearch(R) Cited Ref Sci

(c) 2010 The Thomson Corp. All rights reserved.

11919613 **Genuine Article#:** 708WE **Number of References:** 12

**Title:** Semiconducting nanocomposite from titanium dioxide and organic charge transporting compound ( ABSTRACT AVAILABLE )

**Publication date:** 20030808

## Appendix A-5. Irrelevant Titles

**Journal Subject Category:** MATERIALS SCIENCE, MULTIDISCIPLINARY; PHYSICS, CONDENSED MATTER; POLYMER SCIENCE

**Descriptors:** SCIAuthor Keywords: TPD ; titanium dioxide ; nanoparticle ; semiconducting

**Identifiers:** KeyWord Plus(R): FIELD-EFFECT TRANSISTORS; THIN-FILM TRANSISTORS; POLYMER INTEGRATED-CIRCUITS; HIGH-MOBILITY

7/8/888 (Item 559 from file: 34)

SciSearch(R) Cited Ref Sci

(c) 2010 The Thomson Corp. All rights reserved.

11916489 **Genuine Article#:** BX19D **Number of References:** 21

**Title:** Hydrothermal synthesis of titania nanotube and its application for dye-sensitized solar cell ( ABSTRACT AVAILABLE )

**Publication date:** 20030000

**Journal Subject Category:** CHEMISTRY, PHYSICAL

**Identifiers:** KeyWord Plus(R): TIO2 NANOTUBES; POWDER; OXIDE

7/8/889 (Item 560 from file: 34)

SciSearch(R) Cited Ref Sci

(c) 2010 The Thomson Corp. All rights reserved.

11893385 **Genuine Article#:** 707UR **Number of References:** 27

**Title:** Controlled nanophase development in photocatalytic titania ( ABSTRACT AVAILABLE )

**Publication date:** 20030700

**Journal Subject Category:** MATERIALS SCIENCE, MULTIDISCIPLINARY; METALLURGY & METALLURGICAL ENGINEERING

**Descriptors:** SCIAuthor Keywords: nanoparticles ; catalyst ; titania polytypes ; photoreactivity ; sol gel **processing**

**Identifiers:** KeyWord Plus(R): TEMPERATURE SYNTHESIS; SOL; CHEMISTRY; CLUSTERS; POWDERS; ANATASE; FILM; ACID

7/8/890 (Item 561 from file: 34)

SciSearch(R) Cited Ref Sci

(c) 2010 The Thomson Corp. All rights reserved.

11892847 **Genuine Article#:** 707TU **Number of References:** 27

**Title:** Surface fabrication of hollow nanoarchitectures of ultrathin titania layers from assembled latex particles and tobacco mosaic viruses as templates ( ABSTRACT AVAILABLE )

**Publication date:** 20030805

**Journal Subject Category:** CHEMISTRY, PHYSICAL

**Identifiers:** KeyWord Plus(R): SOL-GEL PROCESS; PLASMA TREATMENT; SPHERES; FILMS; TIO2

## Appendix A-5. Irrelevant Titles

7/8/892 (Item 563 from file: 34)

SciSearch(R) Cited Ref Sci

(c) 2010 The Thomson Corp. All rights reserved.

11817137 **Genuine Article#:** 698JT **Number of References:** 27

**Title:** Effects of Y<sup>3+</sup> dopant on the photoinduced superhydrophilicity of thin nanostructured titania films and its mechanism ( ABSTRACT AVAILABLE )

**Publication date:** 20030700

**Journal Subject Category:** CHEMISTRY, INORGANIC & NUCLEAR

**Descriptors:** SCIAuthor Keywords: Y<sup>3+</sup> doping ; titania ; photoinduced superhydrophilicity ; solid state chemistry

**Identifiers:** KeyWord Plus(R): WATER; TIO<sub>2</sub>(110); SURFACES; POWDERS

7/8/893 (Item 564 from file: 34)

SciSearch(R) Cited Ref Sci

(c) 2010 The Thomson Corp. All rights reserved.

11811776 **Genuine Article#:** 697LG **Number of References:** 25

**Title:** High-temperature high-pressure crystallization and sintering behavior of brookite-free nanostructured titanium dioxide: in situ experiments using synchrotron radiation ( ABSTRACT AVAILABLE )

**Publication date:** 20030626

**Journal Subject Category:** CHEMISTRY, ANALYTICAL; CHEMISTRY, PHYSICAL

**Descriptors:** SCIAuthor Keywords: nanomaterials ; sol-gel synthesis ; phase transitions

**Identifiers:** KeyWord Plus(R): BULK NANOCRYSTALLINE TIO<sub>2</sub>; PHASE-TRANSFORMATION; STRUCTURAL TRANSFORMATIONS; SIZE; STABILIZATION

7/8/894 (Item 565 from file: 34)

SciSearch(R) Cited Ref Sci

(c) 2010 The Thomson Corp. All rights reserved.

11706123 **Genuine Article#:** 685WE **Number of References:** 39

**Title:** Visible and near-IR luminescence via energy transfer in rare earth doped mesoporous titania thin films with nanocrystalline walls ( ABSTRACT AVAILABLE )

**Publication date:** 20030400

**Journal Subject Category:** CHEMISTRY, INORGANIC & NUCLEAR; CHEMISTRY, PHYSICAL

**Descriptors:** SCIAuthor Keywords: europium ; mesoporous materials ; luminescence ; titania ; nanocrystals ; rare earth ; energy transfer

**Identifiers:** KeyWord Plus(R): SOLAR-CELLS; SONOCHEMICAL SYNTHESIS; METAL-OXIDES; TIO<sub>2</sub>; STATES; GLASS; SPECTROSCOPY; FLUORESCENCE; SURFACTANTS; FRAMEWORK

7/8/895 (Item 566 from file: 34)

SciSearch(R) Cited Ref Sci

(c) 2010 The Thomson Corp. All rights reserved.

## Appendix A-5. Irrelevant Titles

11703821 **Genuine Article#:** 685QC **Number of References:** 2  
**Title:** Intracellular localization of titanium dioxide-biomolecule nanocomposites ( ABSTRACT AVAILABLE )  
**Publication date:** 20030300  
**Journal Subject Category:** PHYSICS, MULTIDISCIPLINARY

7/8/896 (Item 567 from file: 34)  
SciSearch(R) Cited Ref Sci  
(c) 2010 The Thomson Corp. All rights reserved.  
11599398 **Genuine Article#:** 672YW **Number of References:** 29  
**Title:** Extreme changes in the electrical resistance of titania nanotubes with hydrogen exposure  
**Publication date:** 20030417  
**Journal Subject Category:** MATERIALS SCIENCE, MULTIDISCIPLINARY  
**Identifiers:** KeyWord Plus(R): SCANNING TUNNELING SPECTROSCOPY; TIO2  
SOLAR-CELLS; CARBON NANOTUBES; THIN-FILMS; NANOCRYSTALLINE;  
CONDUCTIVITY; OXIDATION; DIOXIDE; OXYGEN; OXIDE

7/8/897 (Item 568 from file: 34)  
SciSearch(R) Cited Ref Sci  
(c) 2010 The Thomson Corp. All rights reserved.  
11530330 **Genuine Article#:** 662ZT **Number of References:** 33  
**Title:** Preparation and characterization of clay mineral intercalated titanium dioxide nanoparticles ( ABSTRACT AVAILABLE )  
**Publication date:** 20030401  
**Journal Subject Category:** CHEMISTRY, PHYSICAL  
**Identifiers:** KeyWord Plus(R): PHOTOCATALYTIC ACTIVITY; PILLARED CLAYS;  
HYDROTHERMAL SYNTHESIS; TIO2; ANATASE; PARTICLES; RUTILE;  
HYDROLYSIS; OXIDE; CRYSTALLIZATION

7/8/898 (Item 569 from file: 34)  
SciSearch(R) Cited Ref Sci  
(c) 2010 The Thomson Corp. All rights reserved.  
11495060 **Genuine Article#:** 659ZT **Number of References:** 26  
**Title:** A chemiluminescence study of micron and nanoparticle titanium dioxide: effect on the thermal stability of metallocene polyethylene ( ABSTRACT AVAILABLE )  
**Publication date:** 20030320  
**Journal Subject Category:** CHEMISTRY, PHYSICAL  
**Descriptors:** SCIAuthor Keywords: chemiluminescence ; titanium dioxide ; metallocene polyethylene  
**Identifiers:** KeyWord Plus(R): ANTIOXIDANT EFFECTIVENESS; SEMICONDUCTING POLYMER; POLYPROPYLENE; FILMS; PHOTOOXIDATION; OXIDATION; DIODES

## Appendix A-5. Irrelevant Titles

7/8/899 (Item 570 from file: 34)

SciSearch(R) Cited Ref Sci

(c) 2010 The Thomson Corp. All rights reserved.

11490820 **Genuine Article#:** BW36C **Number of References:** 12

**Title:** Semiconductor nanoparticles in the channels of mesoporous silica and titania thin films ( ABSTRACT AVAILABLE )

**Publication date:** 20020000

**Journal Subject Category:** CHEMISTRY, PHYSICAL

7/8/900 (Item 571 from file: 34)

SciSearch(R) Cited Ref Sci

(c) 2010 The Thomson Corp. All rights reserved.

11473599 **Genuine Article#:** 656GB **Number of References:** 43

**Title:** Labeling the defects of single-walled carbon nanotubes using titanium dioxide nanoparticles ( ABSTRACT AVAILABLE )

**Publication date:** 20030320

**Journal Subject Category:** CHEMISTRY, PHYSICAL

**Identifiers:** KeyWord Plus(R): TIO2; INTERFERENCE; INTERFACES; TRANSPORT; OXIDATION; DIAMETER; GROWTH; ROPES; CELL

7/8/901 (Item 572 from file: 34)

SciSearch(R) Cited Ref Sci

(c) 2010 The Thomson Corp. All rights reserved.

11397031 **Genuine Article#:** 645VW **Number of References:** 44

**Title:** Novel approach to the fabrication of macroporous polymers and their use as a template for crystalline titania nanorings ( ABSTRACT AVAILABLE )

**Publication date:** 20030200

**Journal Subject Category:** CHEMISTRY, MULTIDISCIPLINARY; MATERIALS SCIENCE, MULTIDISCIPLINARY

**Identifiers:** KeyWord Plus(R): LARGE-SCALE SYNTHESIS; PHOTONIC CRYSTALS; HOLLOW SPHERES; INVERSE OPALS; BANDGAP; NANOSTRUCTURES; NANOWIRES; PARTICLES; OXIDATION; ARRAYS

7/8/902 (Item 573 from file: 34)

SciSearch(R) Cited Ref Sci

(c) 2010 The Thomson Corp. All rights reserved.

11366094 **Genuine Article#:** 643XK **Number of References:** 33

**Title:** Self-assembled multilayers of titania nanoparticles and nanosheets with polyelectrolytes ( ABSTRACT AVAILABLE )

**Publication date:** 20030211

**Journal Subject Category:** CHEMISTRY, PHYSICAL; MATERIALS SCIENCE, MULTIDISCIPLINARY

**Identifiers:** KeyWord Plus(R): TIO2 FILMS; ULTRATHIN FILMS; WATER; ACID;

## Appendix A-5. Irrelevant Titles

DECOMPOSITION; CRYSTALLITES; CONVERSION; ELECTRODES

7/8/903 (Item 574 from file: 34)

SciSearch(R) Cited Ref Sci

(c) 2010 The Thomson Corp. All rights reserved.

11324827 **Genuine Article#:** 638JE **Number of References:** 24

**Title:** Separation and preconcentration of Se(IV)/Se(VI) species by selective adsorption onto nanometer-sized titanium dioxide and determination by graphite furnace atomic absorption spectrometry ( ABSTRACT AVAILABLE )

**Publication date:** 20021200

**Journal Subject Category:** BIOCHEMICAL RESEARCH METHODS; CHEMISTRY, ANALYTICAL

**Descriptors:** SCIAuthor Keywords: selenium ; speciation ; preconcentration ; titanium dioxide ; atomic absorption spectrometry

**Identifiers:** KeyWord Plus(R): SEA-WATER; SELENIUM(IV); TIO2

7/8/904 (Item 575 from file: 34)

SciSearch(R) Cited Ref Sci

(c) 2010 The Thomson Corp. All rights reserved.

11248719 **Genuine Article#:** 626VG **Number of References:** 13

**Title:** Nanoarchitecture of titania designed for ruthenium dye-sensitized photoelectrochemical cells ( ABSTRACT AVAILABLE )

**Publication date:** 20021101

**Journal Subject Category:** PHYSICS, APPLIED

**Descriptors:** SCIAuthor Keywords: photoelectrochemical cell ; nanoarchitecture ; anatase ; CVD ; SEM ; XRD

**Identifiers:** KeyWord Plus(R): CHEMICAL-VAPOR-DEPOSITION; ZINC-OXIDE WHISKERS; TIO2 SOLAR-CELLS; EPITAXIAL-GROWTH; ANATASE; FILMS; EFFICIENCY; ELECTRODES

7/8/905 (Item 576 from file: 34)

SciSearch(R) Cited Ref Sci

(c) 2010 The Thomson Corp. All rights reserved.

11214312 **Genuine Article#:** BV62B **Number of References:** 8

**Title:** Physical and spectroscopic characterisation of active nanocrystals in erbium-doped silica-titania sol-gel films

( ABSTRACT AVAILABLE )

**Publication date:** 20020000

**Journal Subject Category:** MATERIALS SCIENCE, CERAMICS; MATERIALS SCIENCE, COMPOSITES

**Descriptors:** SCIAuthor Keywords: ASAXS ; erbium ; EXAFS ; nanocomposite films ; nanocrystals

## Appendix A-5. Irrelevant Titles

**Identifiers:** KeyWord Plus(R): X-RAY-SCATTERING

7/8/906 (Item 577 from file: 34)

SciSearch(R) Cited Ref Sci

(c) 2010 The Thomson Corp. All rights reserved.

11208333 **Genuine Article#:** 622AM **Number of References:** 3

**Title:** Nanostructure manipulation device for transmission electron microscopy: application to titania nanoparticle chain aggregates ( ABSTRACT AVAILABLE )

**Publication date:** 20021200

**Journal Subject Category:** MICROSCOPY

**Descriptors:** SCIAuthor Keywords: nanostructure ; specimen support ; cartridge ; specimen holder ; titania chain aggregates

**Identifiers:** KeyWord Plus(R): ELASTIC BEHAVIOR

7/8/907 (Item 578 from file: 34)

SciSearch(R) Cited Ref Sci

(c) 2010 The Thomson Corp. All rights reserved.

11189638 **Genuine Article#:** 618HK **Number of References:** 27

**Title:** Titanium dioxide nanoparticles co-doped with Fe<sup>3+</sup> and Eu<sup>3+</sup> ions for photocatalysis ( ABSTRACT AVAILABLE )

**Publication date:** 20021200

**Journal Subject Category:** MATERIALS SCIENCE, MULTIDISCIPLINARY; PHYSICS, APPLIED

**Descriptors:** SCIAuthor Keywords: sol-gel ; titanium dioxide ; nanoparticles ; Eu<sup>3+</sup> and Fe<sup>3+</sup> co-doping ; photocatalysis

**Identifiers:** KeyWord Plus(R): VISIBLE-LIGHT; DINITROGEN PHOTOREDUCTION; TIO<sub>2</sub> FILMS; PARTICLES; ELECTRON; SIZE; SENSITIZATION; DEGRADATION; AMMONIA

7/8/908 (Item 579 from file: 34)

SciSearch(R) Cited Ref Sci

(c) 2010 The Thomson Corp. All rights reserved.

11152458 **Genuine Article#:** 612QN **Number of References:** 55

**Title:** Preparation of nanoporous titania films by surface sol-gel process accompanied by low-temperature oxygen plasma treatment ( ABSTRACT AVAILABLE )

**Publication date:** 20021112

**Journal Subject Category:** CHEMISTRY, PHYSICAL

**Identifiers:** KeyWord Plus(R): LANGMUIR-BLODGETT-FILMS; MESOPOROUS SILICA FILMS; TIO<sub>2</sub> ULTRATHIN-FILM; DIP-COATING METHOD; METAL-OXIDE FILMS; THIN-FILMS; POLY(ETHYLENE GLYCOL); ELECTRONIC-STRUCTURE; DIOXIDE; PARTICLES

## Appendix A-5. Irrelevant Titles

7/8/909 (Item 580 from file: 34)

SciSearch(R) Cited Ref Sci

(c) 2010 The Thomson Corp. All rights reserved.

11151584 **Genuine Article#:** 614HC **Number of References:** 27

**Title:** New hydrolytic process for producing zirconium dioxide, tin dioxide, and titanium dioxide nanoparticles ( ABSTRACT AVAILABLE )

**Publication date:** 20021100

**Journal Subject Category:** MATERIALS SCIENCE, CERAMICS

**Identifiers:** KeyWord Plus(R): ELECTRICAL-PROPERTIES; SENSORS; PHASE; SNO2; DEPOSITION; PARTICLES; FILMS; ZRO2

7/8/910 (Item 581 from file: 34)

SciSearch(R) Cited Ref Sci

(c) 2010 The Thomson Corp. All rights reserved.

11112561 **Genuine Article#:** 607JU **Number of References:** 6

**Title:** Deposition of titania nanoparticles on spherical silica ( ABSTRACT AVAILABLE )

**Publication date:** 20030100

**Journal Subject Category:** MATERIALS SCIENCE, CERAMICS

**Descriptors:** SCIAuthor Keywords: isoelectric point (IEP) ; nano sol ; peptization ; pH ; titania-coated silica

**Identifiers:** KeyWord Plus(R): COATINGS

7/8/911 (Item 582 from file: 34)

SciSearch(R) Cited Ref Sci

(c) 2010 The Thomson Corp. All rights reserved.

11098497 **Genuine Article#:** 604VG **Number of References:** 32

**Title:** Spin-on-based fabrication of titania nanowires using a sol-gel process ( ABSTRACT AVAILABLE )

**Publication date:** 20021000

**Journal Subject Category:** CHEMISTRY, MULTIDISCIPLINARY; MATERIALS SCIENCE, MULTIDISCIPLINARY

**Identifiers:** KeyWord Plus(R): THIN-FILMS; POLYMER-FILMS; NM; PLANARIZATION; GRATINGS; MEMBRANE; SPHERES; ARRAYS; WIRES; SNO2

7/8/912 (Item 583 from file: 34)

SciSearch(R) Cited Ref Sci

(c) 2010 The Thomson Corp. All rights reserved.

11058852 **Genuine Article#:** 602GM **Number of References:** 28

**Title:** Preparation of rutile titania nanocrystals by liquid method at room temperature ( ABSTRACT AVAILABLE )

**Publication date:** 20030115

**Journal Subject Category:** MATERIALS SCIENCE, MULTIDISCIPLINARY

## Appendix A-5. Irrelevant Titles

**Descriptors:** SCIAuthor Keywords: rutile titania ; nanocrystals ; preparation ; peptizing ; liquid phase ; room temperature

**Identifiers:** KeyWord Plus(R): PHASE-TRANSFORMATION; ANATASE; KINETICS; OXIDES; TIO<sub>2</sub>; MECHANISM; SOL

7/8/913 (Item 584 from file: 34)

SciSearch(R) Cited Ref Sci

(c) 2010 The Thomson Corp. All rights reserved.

10983046 **Genuine Article#:** 590KB **Number of References:** 17

**Title:** Preparation of nanosized titania by hydrolysis of alkoxide titanium in micelles ( ABSTRACT AVAILABLE )

**Publication date:** 20020808

**Journal Subject Category:** MATERIALS SCIENCE, MULTIDISCIPLINARY

**Descriptors:** SCIAuthor Keywords: nano structures ; oxides ; chemical synthesis ; phase transactions

**Identifiers:** KeyWord Plus(R): NANOPHASE TIO<sub>2</sub>; MICROEMULSION; PARAMETERS; PARTICLES; MEMBRANES

7/8/914 (Item 585 from file: 34)

SciSearch(R) Cited Ref Sci

(c) 2010 The Thomson Corp. All rights reserved.

10959077 **Genuine Article#:** 588MH **Number of References:** 44

**Title:** Titania nanostructured films derived from a titania nanosheet/polycation multilayer assembly via heat treatment and UV irradiation ( ABSTRACT AVAILABLE )

**Publication date:** 20020800

**Journal Subject Category:** CHEMISTRY, PHYSICAL; MATERIALS SCIENCE, MULTIDISCIPLINARY

**Identifiers:** KeyWord Plus(R): SOL-GEL PROCESS; TIO<sub>2</sub> FILMS; NANOSHEET CRYSTALLITES; ULTRATHIN FILMS; OXIDATION; ACID; NANOCRYSTALLITES; MONOLAYERS; SURFACES; LAYERS

7/8/915 (Item 586 from file: 34)

SciSearch(R) Cited Ref Sci

(c) 2010 The Thomson Corp. All rights reserved.

10949416 **Genuine Article#:** 588JC **Number of References:** 34

**Title:** Osteoblast and chondrocyte proliferation in the presence of alumina and titania nanoparticles ( ABSTRACT AVAILABLE )

**Publication date:** 20020600

**Journal Subject Category:** CHEMISTRY, MULTIDISCIPLINARY; MATERIALS SCIENCE, MULTIDISCIPLINARY

**Descriptors:** SCIAuthor Keywords: nanoceramics ; particles ; alumina ; titania ; osteoblasts ; chondrocytes ; orthopedic ; biomedicine

**Identifiers:** KeyWord Plus(R): POLYETHYLENE WEAR DEBRIS; NANOPHASE

## Appendix A-5. Irrelevant Titles

CERAMICS; PARTICLES; ADHESION; SIZE; ACTIVATION; CELLS; SHAPE

7/8/916 (Item 587 from file: 34)

SciSearch(R) Cited Ref Sci

(c) 2010 The Thomson Corp. All rights reserved.

10860213 **Genuine Article#:** 576ZD **Number of References:** 19

**Title:** Charge transport in porous nanocrystalline titanium dioxide ( ABSTRACT AVAILABLE )

**Publication date:** 20020400

**Journal Subject Category:** PHYSICS, CONDENSED MATTER

**Descriptors:** SCIAuthor Keywords: TiO<sub>2</sub> ; solar cells ; light ; photoconductivity ; charge transport ; recombination

**Identifiers:** KeyWord Plus(R): TIO2 FILMS; OXIDE ELECTRODES; SOLAR-CELL; RECOMBINATION; TRANSIENTS

7/8/917 (Item 588 from file: 34)

SciSearch(R) Cited Ref Sci

(c) 2010 The Thomson Corp. All rights reserved.

10858835 **Genuine Article#:** 576MR **Number of References:** 20

**Title:** Promoted phase transition of titania nanoparticles prepared by a photo-assisted sol-gel method ( ABSTRACT AVAILABLE )

**Publication date:** 20020000

**Journal Subject Category:** CHEMISTRY, MULTIDISCIPLINARY

**Identifiers:** KeyWord Plus(R): TIO2 SURFACES; PHOTOCATALYTIC ACTIVITY; NANOPHASE TIO<sub>2</sub>; RAMAN-SPECTRUM; TIO<sub>2</sub>(110); DEFECTS

7/8/918 (Item 589 from file: 34)

SciSearch(R) Cited Ref Sci

(c) 2010 The Thomson Corp. All rights reserved.

10834418 **Genuine Article#:** 574DG **Number of References:** 22

**Title:** Alumina and titania multilayer membranes for nanofiltration: preparation, characterization and chemical stability ( ABSTRACT AVAILABLE )

**Publication date:** 20020901

**Journal Subject Category:** ENGINEERING, CHEMICAL; POLYMER SCIENCE

**Descriptors:** SCIAuthor Keywords: ceramic membranes ; sol-gel ; characterization ; chemical stability ; nanofiltration

**Identifiers:** KeyWord Plus(R): CERAMIC MEMBRANES

7/8/919 (Item 590 from file: 34)

SciSearch(R) Cited Ref Sci

(c) 2010 The Thomson Corp. All rights reserved.

10827977 **Genuine Article#:** 574CG **Number of References:** 55

## Appendix A-5. Irrelevant Titles

**Title: Population balance modeling of flame synthesis of titania nanoparticles ( ABSTRACT AVAILABLE )**

**Publication date:** 20020600

**Journal Subject Category:** ENGINEERING, CHEMICAL

**Descriptors:** SCIAuthor Keywords: **population** balance ; titania ; nanoparticle

**Identifiers:** KeyWord Plus(R): CHEMICAL VAPOR-DEPOSITION; TIO2 PARTICLES; GAS-PHASE; AGGLOMERATE PARTICLES; DIFFUSION FLAME; PIVOT TECHNIQUE; CVD METHOD; FT-IR; COAGULATION; GROWTH

7/8/920 (Item 591 from file: 34)

SciSearch(R) Cited Ref Sci

(c) 2010 The Thomson Corp. All rights reserved.

10792465 **Genuine Article#:** 570PV **Number of References:** 18

**Title: Visible frequency thin film photonic crystals from colloidal systems of nanocrystalline titania and polystyrene microspheres ( ABSTRACT AVAILABLE )**

**Publication date:** 20020600

**Journal Subject Category:** MATERIALS SCIENCE, CERAMICS

**Identifiers:** KeyWord Plus(R): ORDERED MACROPOROUS MATERIALS; OPTICAL WAVELENGTHS; BAND-GAP; ARRAYS; VOIDS

7/8/921 (Item 592 from file: 34)

SciSearch(R) Cited Ref Sci

(c) 2010 The Thomson Corp. All rights reserved.

10773290 **Genuine Article#:** 567RC **Number of References:** 21

**Title: Cadmium removal from water using thiolactic acid-modified titanium dioxide nanoparticles ( ABSTRACT AVAILABLE )**

**Publication date:** 20020531

**Journal Subject Category:** CHEMISTRY, PHYSICAL

**Descriptors:** SCIAuthor Keywords: titanium dioxides ; cadmium ; reduction ; photocatalysis

**Identifiers:** KeyWord Plus(R): PHOTOCATALYTIC REDUCTION; SURFACE MODIFICATION; TIO2 COLLOIDS; METAL-IONS; XAFS

7/8/922 (Item 593 from file: 34)

SciSearch(R) Cited Ref Sci

(c) 2010 The Thomson Corp. All rights reserved.

10773244 **Genuine Article#:** 567RC **Number of References:** 24

**Title: Photoconductivity and charge trapping in porous nanocrystalline titanium dioxide ( ABSTRACT AVAILABLE )**

**Publication date:** 20020531

**Journal Subject Category:** CHEMISTRY, PHYSICAL

**Descriptors:** SCIAuthor Keywords: TiO2 ; photoconductivity ; light ; solar cells ; photocatalysis ; trap states

**Identifiers:**

## Appendix A-5. Irrelevant Titles

KeyWord Plus(R): TIO2 FILMS; OXIDE ELECTRODES; TRANSPORT;  
RECOMBINATION; CELLS; EFFICIENCY; TRANSIENTS; ANATASE

7/8/923 (Item 594 from file: 34)

SciSearch(R) Cited Ref Sci

(c) 2010 The Thomson Corp. All rights reserved.

10741403 **Genuine Article#:** 565BE **Number of References:** 10

**Title: Phase-compositional and morphological control of titania nanoparticles via low temperature dissolution-precipitation process in liquid media ( ABSTRACT AVAILABLE )**

**Publication date:** 20020605

**Journal Subject Category:** CHEMISTRY, MULTIDISCIPLINARY

**Identifiers:** KeyWord Plus(R): CRYSTALLITES; ANATASE

7/8/924 (Item 595 from file: 34)

SciSearch(R) Cited Ref Sci

(c) 2010 The Thomson Corp. All rights reserved.

10732821 **Genuine Article#:** 562KC **Number of References:** 18

**Title: Zirconia-titania nanofilm with composition gradient ( ABSTRACT AVAILABLE )**

**Publication date:** 20020600

**Journal Subject Category:** CHEMISTRY, MULTIDISCIPLINARY; MATERIALS SCIENCE, MULTIDISCIPLINARY

**Identifiers:** KeyWord Plus(R): LANGMUIR-BLODGETT-FILMS; SOL-GEL PROCESS; THIN-FILMS

7/8/925 (Item 596 from file: 34)

SciSearch(R) Cited Ref Sci

(c) 2010 The Thomson Corp. All rights reserved.

10724786 **Genuine Article#:** 562QG **Number of References:** 16

**Title: Application of titania nanotubes to a dye-sensitized solar cell ( ABSTRACT AVAILABLE )**

**Publication date:** 20020600

**Journal Subject Category:** ELECTROCHEMISTRY

**Descriptors:** SCIAuthor Keywords: dye-sensitized solar cell ; hydrothermal synthesis ; titanium dioxide ; titania nanotube

**Identifiers:** KeyWord Plus(R): OXIDE

7/8/926 (Item 597 from file: 34)

SciSearch(R) Cited Ref Sci

(c) 2010 The Thomson Corp. All rights reserved.

## Appendix A-5. Irrelevant Titles

10685433 **Genuine Article#:** 555MF **Number of References:** 25

**Title:** Effects of erbium oxalate content and temperature on green up-conversion luminescence of erbium oxalate nanoparticles/titania/ormosil composite thin films ( ABSTRACT AVAILABLE )

**Publication date:** 20020515

**Journal Subject Category:** OPTICS

**Descriptors:** SCIAuthor Keywords: nanoparticle ; ormosil ; sol-gel thin film ; up-conversion emission ; lifetime

**Identifiers:** KeyWord Plus(R): 800 NM EXCITATION; RARE-EARTH IONS; ER3+ IONS; FLUOROZIRCONATE GLASSES; EMISSION; FLUORESCENCE; NANOCRYSTALS; SPECTROSCOPY; TRANSITIONS; FIBER

7/8/927 (Item 598 from file: 34)

SciSearch(R) Cited Ref Sci

(c) 2010 The Thomson Corp. All rights reserved.

10643920 **Genuine Article#:** 550GG **Number of References:** 25

**Title:** Synthesis and microstructural control of nanocrystalline titania powders via a stearic acid method ( ABSTRACT AVAILABLE )

**Publication date:** 20020500

**Journal Subject Category:** MATERIALS SCIENCE, MULTIDISCIPLINARY

**Descriptors:** SCIAuthor Keywords: stearic acid method ; nanocrystalline titania ; doping ; microstructure

**Identifiers:** KeyWord Plus(R): SOL-GEL PROCESS; TIO2; OXIDE; ANATASE; DIOXIDE; SIZE

7/8/928 (Item 599 from file: 34)

SciSearch(R) Cited Ref Sci

(c) 2010 The Thomson Corp. All rights reserved.

10600825 **Genuine Article#:** 546UK **Number of References:** 36

**Title:** Study of anatase to rutile phase transition in nanocrystalline titania films ( ABSTRACT AVAILABLE )

**Publication date:** 20020700

**Journal Subject Category:** MATERIALS SCIENCE, CERAMICS

**Descriptors:** SCIAuthor Keywords: titania films ; nanocrystalline ; sol-gel ; complexing agent-assisted ; Raman ; FTIR ; XRD

**Identifiers:** KeyWord Plus(R): TIO2 THIN-FILMS; RAMAN-SCATTERING; TRANSFORMATION; SIZE; NUCLEATION; EVOLUTION; COATINGS; SPECTRUM; FTIR

7/8/929 (Item 600 from file: 34)

SciSearch(R) Cited Ref Sci

(c) 2010 The Thomson Corp. All rights reserved.

10563186 **Genuine Article#:** 539XK **Number of References:** 20

**Title:** Low temperature synthesis of nanosize rutile titania crystal in liquid media (

## Appendix A-5. Irrelevant Titles

ABSTRACT AVAILABLE )

**Publication date:** 20020428

**Journal Subject Category:** MATERIALS SCIENCE, MULTIDISCIPLINARY

**Descriptors:** SCIAuthor Keywords: titania ; low temperature solution reaction ; dissolution-reprecipitation **process** ; photocatalyst

**Identifiers:** KeyWord Plus(R): TIO2 ULTRAFINE POWDERS; CRYSTALLIZATION; PRECIPITATION; DIOXIDE; PHASE

7/8/930 (Item 601 from file: 34)

SciSearch(R) Cited Ref Sci

(c) 2010 The Thomson Corp. All rights reserved.

10460727 **Genuine Article#:** 530MA **Number of References:** 30

**Title:** Effects of oxygen on the properties of titania nanoparticles prepared by MOCVD ( ABSTRACT AVAILABLE )

**Publication date:** 20020401

**Journal Subject Category:** MATERIALS SCIENCE, MULTIDISCIPLINARY

**Identifiers:** KeyWord Plus(R): CHEMICAL-VAPOR-DEPOSITION; GAN BUFFER LAYER; AEROSOL-PARTICLES; PHASE HYDROLYSIS; THERMOPHORESIS; DECOMPOSITION; SUBSTRATE; MECHANISM; ALKOXIDE; POWDER

7/8/931 (Item 602 from file: 34)

SciSearch(R) Cited Ref Sci

(c) 2010 The Thomson Corp. All rights reserved.

10458060 **Genuine Article#:** 529FA **Number of References:** 13

**Title:** Preparation, morphology, wettability and mechanism of nanometer titania film ( ABSTRACT AVAILABLE )

**Publication date:** 20010000

**Journal Subject Category:** MATERIALS SCIENCE, MULTIDISCIPLINARY

**Descriptors:** SCIAuthor Keywords: sol-gel ; scanning probe microscope ; contact angle ; oxygen vacancy ; amphiphobic

**Identifiers:** KeyWord Plus(R): PHOTOCATALYTIC ACTIVITY; SURFACES; WATER; TIO2(110)

7/8/932 (Item 603 from file: 34)

SciSearch(R) Cited Ref Sci

(c) 2010 The Thomson Corp. All rights reserved.

10455040 **Genuine Article#:** 528FH **Number of References:** 23

**Title:** Synthesis of nanoscale shell-core titania coated silica particles in the presence of polyether polyamine and the phase transition ( ABSTRACT AVAILABLE )

**Publication date:** 20020200

**Journal Subject Category:** CHEMISTRY, MULTIDISCIPLINARY

**Descriptors:** SCIAuthor Keywords: nanoscale particle ; silica sol ; titania coated silica

**Identifiers:** KeyWord Plus(R): POWDERS; TETRAETHOXIDE; HYDROLYSIS

## Appendix A-5. Irrelevant Titles

7/8/933 (Item 604 from file: 34)

SciSearch(R) Cited Ref Sci

(c) 2010 The Thomson Corp. All rights reserved.

10390044 **Genuine Article#:** 521UM **Number of References:** 24

**Title:** Photocatalytic characteristics of nanometer-sized titania powders fabricated by a homogeneous-precipitation process ( ABSTRACT AVAILABLE )

**Publication date:** 20020200

**Journal Subject Category:** MATERIALS SCIENCE, CERAMICS

**Identifiers:** KeyWord Plus(R): TIO2 POWDERS; OXIDATION; PARTICLES; ANATASE; RUTILE; HYDROLYSIS; KINETICS

7/8/934 (Item 605 from file: 34)

SciSearch(R) Cited Ref Sci

(c) 2010 The Thomson Corp. All rights reserved.

10368490 **Genuine Article#:** 519MF **Number of References:** 11

**Title:** Synthesis of titania-supported copper nanoparticles via refined alkoxide sol-gel process ( ABSTRACT AVAILABLE )

**Publication date:** 20010600

**Journal Subject Category:** CHEMISTRY, MULTIDISCIPLINARY; MATERIALS SCIENCE, MULTIDISCIPLINARY

**Descriptors:** SCIAuthor Keywords: TiO2 ; copper ; sol-gel ; hydrolysis ; alkoxide

**Identifiers:** KeyWord Plus(R): PHOTOCATALYTIC REDUCTION; PRECURSOR; ZIRCONIA; H2O

7/8/935 (Item 606 from file: 34)

SciSearch(R) Cited Ref Sci

(c) 2010 The Thomson Corp. All rights reserved.

10368483 **Genuine Article#:** 519MG **Number of References:** 17

**Title:** Nanoparticle microreactor: Application to synthesis of titania by thermal decomposition of titanium tetraisopropoxide ( ABSTRACT AVAILABLE )

**Publication date:** 20010800

**Journal Subject Category:** CHEMISTRY, MULTIDISCIPLINARY; MATERIALS SCIENCE, MULTIDISCIPLINARY

**Descriptors:** SCIAuthor Keywords: nanoparticle microreactor ; gas phase synthesis ; nucleation ; TiO2 ; titanium tetraisopropoxide

**Identifiers:** KeyWord Plus(R): CHEMICAL-VAPOR-DEPOSITION; GAS-PHASE; PARTICLE-SIZE; TIO2; GROWTH

7/8/936 (Item 607 from file: 34)

SciSearch(R) Cited Ref Sci

(c) 2010 The Thomson Corp. All rights reserved.

10368481 **Genuine Article#:** 519MG **Number of References:** 89

**Title:** Degradation of sucrose and nitrate over titania coated nano -hematite

## Appendix A-5. Irrelevant Titles

**photocatalysts** ( ABSTRACT AVAILABLE )

**Publication date:** 20010800

**Journal Subject Category:** CHEMISTRY, MULTIDISCIPLINARY; MATERIALS SCIENCE, MULTIDISCIPLINARY

**Descriptors:** SCIAuthor Keywords: photocatalysis ; titanium dioxide ; hematite ; iron oxide ; sucrose ; nitrate reduction

**Identifiers:** KeyWord Plus(R): HETEROGENEOUS PHOTOCATALYSIS; AQUEOUS SUSPENSIONS; SEMICONDUCTOR POWDERS; OXIDE PHOTOCATALYSTS; TIO2 PHOTOCATALYST; COLLOIDAL TIO2; QUANTUM YIELDS; NATURAL-WATERS; IRON-OXIDES; OXIDATION

7/8/937 (Item 608 from file: 34)

SciSearch(R) Cited Ref Sci

(c) 2010 The Thomson Corp. All rights reserved.

10345598 **Genuine Article#:** 514UK **Number of References:** 37

**Title:** Synthesis and characterization of titania nanostructures on glass by Al anodization and sol-gel process ( ABSTRACT AVAILABLE )

**Publication date:** 20020100

**Journal Subject Category:** CHEMISTRY, PHYSICAL; MATERIALS SCIENCE, MULTIDISCIPLINARY

**Identifiers:** KeyWord Plus(R): ANODICALLY OXIDIZED ALUMINUM; TEMPLATE-SYNTHESIS; 2-STEP REPLICATION; POROUS ALUMINA; OXIDE; MEMBRANES; NANOMATERIALS; NANOTUBES; FILM; NANOPARTICLES

7/8/938 (Item 609 from file: 34)

SciSearch(R) Cited Ref Sci

(c) 2010 The Thomson Corp. All rights reserved.

10312769 **Genuine Article#:** 511EC **Number of References:** 14

**Title:** Nanoporous Titania synthesized by a nanoscale casting process in supercritical carbon dioxide ( ABSTRACT AVAILABLE )

**Publication date:** 20020100

**Journal Subject Category:** MATERIALS SCIENCE, CERAMICS

**Identifiers:** KeyWord Plus(R): FLUID; CO2

7/8/939 (Item 610 from file: 34)

SciSearch(R) Cited Ref Sci

(c) 2010 The Thomson Corp. All rights reserved.

10312052 **Genuine Article#:** 510RH **Number of References:** 28

**Title:** Study of the phase transition and the thermal nitridation of nanocrystalline sol-gel titania films ( ABSTRACT AVAILABLE )

**Publication date:** 20020100

**Journal Subject Category:** MATERIALS SCIENCE, CERAMICS

**Identifiers:** KeyWord Plus(R): RAY PHOTOELECTRON-SPECTROSCOPY; CHEMICAL

## Appendix A-5. Irrelevant Titles

VAPOR-DEPOSITION; THIN-FILMS; TIN; FIBERS

7/8/940 (Item 611 from file: 34)

SciSearch(R) Cited Ref Sci

(c) 2010 The Thomson Corp. All rights reserved.

10311921 **Genuine Article#:**

511PJ **Number of References:** 32

**Title:** Nanosized anatase TiO<sub>2</sub> as precursor for preparation of sulfated titania catalysts ( ABSTRACT AVAILABLE )

**Publication date:** 20020123

**Journal Subject Category:** CHEMISTRY, PHYSICAL

**Descriptors:** SCIAuthor Keywords: sol-gel hydrothermal **process** ; nanosized TiO<sub>2</sub> ; sulfated titania ; solid acid catalyst

**Identifiers:** KeyWord Plus(R): SOLID-ACID CATALYSTS; DOPED ZRO<sub>2</sub>; ZIRCONIA; ALKYLATION; SUPERACIDS; AL; SO<sub>4</sub><sup>2-</sup>/TIO<sub>2</sub>/LA<sub>3</sub><sup>+</sup>; TEMPERATURE; SURFACE; CFC-12

7/8/941 (Item 612 from file: 34)

SciSearch(R) Cited Ref Sci

(c) 2010 The Thomson Corp. All rights reserved.

10296844 **Genuine Article#:** 508GQ **Number of References:** 14

**Title:** Surface activation by Pt-nanoclusters on titania for gas sensing applications ( ABSTRACT AVAILABLE )

**Publication date:** 20020102

**Journal Subject Category:** MATERIALS SCIENCE, MULTIDISCIPLINARY

**Descriptors:** SCIAuthor Keywords: platinum ; titanium dioxide ; impregnation ; clusters distribution ; gas sensors

**Identifiers:** KeyWord Plus(R): TIO<sub>2</sub> THIN-FILMS; SOL-GEL METHOD; POLLUTION; SENSOR; NB

7/8/942 (Item 613 from file: 34)

SciSearch(R) Cited Ref Sci

(c) 2010 The Thomson Corp. All rights reserved.

10271503 **Genuine Article#:** 507TG **Number of References:** 20

**Title:** Sonochemical synthesis of titania whiskers and nanotubes ( ABSTRACT AVAILABLE )

**Publication date:** 20011221

**Journal Subject Category:** CHEMISTRY, MULTIDISCIPLINARY

**Identifiers:** KeyWord Plus(R): CARBON NANOTUBES; NANOSTRUCTURES; DIOXIDE

## Appendix A-5. Irrelevant Titles

7/8/943 (Item 614 from file: 34)

SciSearch(R) Cited Ref Sci

(c) 2010 The Thomson Corp. All rights reserved.

10264401 **Genuine Article#:** 503TK **Number of References:** 3

**Title:** Preparation of sol-gel derived nanocrystalline TiO<sub>2</sub> particles in titania-silica composite for photocatalytic applications ( ABSTRACT AVAILABLE )

**Publication date:** 20010000

**Journal Subject Category:** CRYSTALLOGRAPHY

**Descriptors:** SCIAuthor Keywords: photocatalyst ; titania-silica nanocomposite ; sol-gel process

7/8/944 (Item 615 from file: 34)

SciSearch(R) Cited Ref Sci

(c) 2010 The Thomson Corp. All rights reserved.

10229741 **Genuine Article#:** BT32X **Number of References:** 5

**Title:** Characteristics of nano-sized titania prepared by sol-gel polymeric route ( ABSTRACT AVAILABLE )

**Publication date:** 20020000

**Journal Subject Category:** MATERIALS SCIENCE, CERAMICS; MATERIALS SCIENCE, COMPOSITES

**Descriptors:** SCIAuthor Keywords: nanoparticles ; titania ; sol-gel ; particle size ; properties

7/8/945 (Item 616 from file: 34)

SciSearch(R) Cited Ref Sci

(c) 2010 The Thomson Corp. All rights reserved.

10220595 **Genuine Article#:** 499VJ **Number of References:** 33

**Title:** Factors that affect protein adsorption on nanostructured titania films. A novel spectroelectrochemical application to sensing ( ABSTRACT AVAILABLE )

**Publication date:** 20011211

**Journal Subject Category:** CHEMISTRY, PHYSICAL

**Identifiers:** KeyWord Plus(R): NITRIC-OXIDE; CYTOCHROME-C; TIO<sub>2</sub> FILMS; ELECTRODES; ELECTROCHEMISTRY; ENCAPSULATION; SPECTROSCOPY; VOLTAMMETRY; MYOGLOBIN

7/8/946 (Item 617 from file: 34)

SciSearch(R) Cited Ref Sci

(c) 2010 The Thomson Corp. All rights reserved.

10099128 **Genuine Article#:** 487AM **Number of References:** 32

**Title:** Size distribution change of titania nano-particle agglomerates generated by gas phase reaction, agglomeration, and sintering ( ABSTRACT AVAILABLE )

**Publication date:** 20011100

**Journal Subject Category:** ENGINEERING, MECHANICAL; ENVIRONMENTAL SCIENCES

## Appendix A-5. Irrelevant Titles

**Identifiers:** KeyWord Plus(R): CHEMICAL VAPOR-DEPOSITION; TIO2 PARTICLES; AEROSOL; COAGULATION; COALESCENCE; OXIDATION; EVOLUTION; KINETICS; EQUATION; POWDER

7/8/947 (Item 618 from file: 34)

SciSearch(R) Cited Ref Sci

(c) 2010 The Thomson Corp. All rights reserved.

10024709 **Genuine Article#:** 475RG **Number of References:** 34

**Title:** The synthesis of nanocrystalline anatase and rutile titania in mixed organic media ( ABSTRACT AVAILABLE )

**Publication date:** 20010924

**Journal Subject Category:** CHEMISTRY, INORGANIC & NUCLEAR

**Identifiers:** KeyWord Plus(R): SOL-GEL PROCESS; ELECTRICAL-PROPERTIES; AMORPHOUS TITANIA; DIOXIDE PARTICLES; TIO2; SEMICONDUCTOR; SPECTROSCOPY; TEMPERATURE; SENSORS; OXIDE

7/8/948 (Item 619 from file: 34)

SciSearch(R) Cited Ref Sci

(c) 2010 The Thomson Corp. All rights reserved.

10019566 **Genuine Article#:** 477ML **Number of References:** 14

**Title:** Nanoparticle routes to mesoporous titania thin films ( ABSTRACT AVAILABLE )

**Publication date:** 20010921

**Journal Subject Category:** CHEMISTRY, MULTIDISCIPLINARY

**Identifiers:** KeyWord Plus(R): SURFACTANTS; TIO2

7/8/949 (Item 620 from file: 34)

SciSearch(R) Cited Ref Sci

(c) 2010 The Thomson Corp. All rights reserved.

09991749 **Genuine Article#:** 472DM **Number of References:** 22

**Title:** High surface area anatase titania nanoparticles prepared by MOCVD ( ABSTRACT AVAILABLE )

**Publication date:** 20011003

**Journal Subject Category:** MATERIALS SCIENCE, MULTIDISCIPLINARY; PHYSICS, CONDENSED MATTER

**Descriptors:** SCIAuthor Keywords: MOCVD ; titania ; nanoparticles ; anatase ; transformation

**Identifiers:** KeyWord Plus(R): CHEMICAL-VAPOR-DEPOSITION; GAN BUFFER LAYER; PHASE-TRANSFORMATION; TIO2; HYDROLYSIS; GROWTH; THERMOPHORESIS; EVOLUTION; SUBSTRATE; MEMBRANES

7/8/950 (Item 621 from file: 34)

## Appendix A-5. Irrelevant Titles

SciSearch(R) Cited Ref Sci

(c) 2010 The Thomson Corp. All rights reserved.

09925997 **Genuine Article#:** 464XX **Number of References:** 25

**Title:** Nanometer-sized titanium dioxide micro-column on-line preconcentration of La, Y, Yb, Eu, Dy and their determination by inductively coupled plasma atomic emission spectrometry ( ABSTRACT AVAILABLE )

**Publication date:** 20010800

**Journal Subject Category:** CHEMISTRY, ANALYTICAL; SPECTROSCOPY

**Identifiers:** KeyWord Plus(R): RARE-EARTH ELEMENTS; NEUTRON-ACTIVATION ANALYSIS; MASS-SPECTROMETRY; ICP-AES; PARTICLES; METAL; SEPARATION/PRECONCENTRATION; BEHAVIOR; YTTRIUM; ROCKS

7/8/951 (Item 622 from file: 34)

SciSearch(R) Cited Ref Sci

(c) 2010 The Thomson Corp. All rights reserved.

09768811 **Genuine Article#:** 444QJ **Number of References:** 22

**Title:** Electrochemically induced surface modification of titanols in a 'nanoglued' titania aerogel-silica aerogel composite film ( ABSTRACT AVAILABLE )

**Publication date:** 20010601

**Journal Subject Category:** MATERIALS SCIENCE, CERAMICS

**Identifiers:** KeyWord Plus(R): POLYCRYSTALLINE TIO<sub>2</sub> ELECTRODES; FLAT-BAND POTENTIALS; SPECTROSCOPIC DETERMINATION; ANATASE ELECTRODES; ACCUMULATION; ADSORPTION; SOL

7/8/952 (Item 623 from file: 34)

SciSearch(R) Cited Ref Sci

(c) 2010 The Thomson Corp. All rights reserved.

09691718 **Genuine Article#:** 437KH **Number of References:** 17

**Title:** Synthesis of titanium dioxide nanoparticles by reversible reaction in semibatch-batch mixed method ( ABSTRACT AVAILABLE )

**Publication date:** 20010500

**Journal Subject Category:** CHEMISTRY, MULTIDISCIPLINARY; ENGINEERING, CHEMICAL

**Descriptors:** SCIAuthor Keywords: titanium dioxide ; reversible reaction ; nanoparticles ; semibatch-batch

**Identifiers:** KeyWord Plus(R): HPC DISPERSANT; HYDROLYSIS; PARTICLES; TIO<sub>2</sub>; CONDENSATION; POWDERS

7/8/953 (Item 624 from file: 34)

SciSearch(R) Cited Ref Sci

(c) 2010 The Thomson Corp. All rights reserved.

09588476 **Genuine Article#:** 425BR **Number of References:** 21

**Title:** Structural characterization and formation mechanism of surface-modified titanium dioxide nanoparticles ( ABSTRACT AVAILABLE )

## Appendix A-5. Irrelevant Titles

**Publication date:** 20010400

**Journal Subject Category:** CHEMISTRY, PHYSICAL

**Descriptors:** SCIAuthor Keywords: titanium dioxide ; surface modification ; nanoparticles ; sol-gel ; competitive reaction

**Identifiers:** KeyWord Plus(R): RAY PHOTOELECTRON-SPECTROSCOPY; SILVER NANOPARTICLES; PARTICLES; TIO2; CERAMICS

7/8/954 (Item 625 from file: 34)

SciSearch(R) Cited Ref Sci

(c) 2010 The Thomson Corp. All rights reserved.

09434182 **Genuine Article#:** 405CG **Number of References:** 65

**Title:** Multilayered titania, silica, and Laponite nanoparticle coatings on polystyrene colloidal templates and resulting inorganic hollow spheres ( ABSTRACT AVAILABLE )

**Publication date:** 20010200

**Journal Subject Category:** CHEMISTRY, PHYSICAL; MATERIALS SCIENCE, MULTIDISCIPLINARY

**Identifiers:** KeyWord Plus(R): CORE-SHELL PARTICLES; OPTICAL-PROPERTIES; CONSECUTIVE ADSORPTION; SPHERICAL-PARTICLES; ENZYME MULTILAYERS; DIOXIDE FILMS; THIN-FILMS; POLYELECTROLYTE; OXIDE; TIO2

7/8/955 (Item 626 from file: 34)

SciSearch(R) Cited Ref Sci

(c) 2010 The Thomson Corp. All rights reserved.

09407384 **Genuine Article#:** 400EB **Number of References:** 27

**Title:** Fabrication and evaluation of plasma sprayed nanostructured alumina- titania coatings with superior properties ( ABSTRACT AVAILABLE )

**Publication date:** 20010315

**Journal Subject Category:** MATERIALS SCIENCE, MULTIDISCIPLINARY

**Descriptors:** SCIAuthor Keywords: alumina-titania coatings ; thermal spray ; nanomaterials

**Identifiers:** KeyWord Plus(R): CEMENTED CARBIDES

7/8/956 (Item 1 from file: 35)

Dissertation Abs Online

(c) 2009 ProQuest Info&Learning. All rights reserved.

02417487 ORDER NO: AADAA-I1464419

**Geometry and morphology of titanium dioxide and hematite nanotubes for solar photolysis of water**

**Year:** 2009

**Descriptors:** ENGINEERING, MATERIALS SCIENCE

**Descriptor Codes:** 0794

## Appendix A-5. Irrelevant Titles

7/8/957 (Item 2 from file: 35)

Dissertation Abs Online

(c) 2009 ProQuest Info&Learning. All rights reserved.

02412499 ORDER NO: AADAA-I3352742

**The morphology and catalytic activity of bimetallic nanoclusters supported on titanium dioxide (110)**

**Year: 2009**

**Descriptors:** CHEMISTRY, PHYSICAL

**Descriptor Codes:** 0494

7/8/958 (Item 3 from file: 35)

Dissertation Abs Online

(c) 2009 ProQuest Info&Learning. All rights reserved.

02412261 ORDER NO: AADAA-I3352546

**Titanium dioxide/carbon nanotube composite for photoreactive membrane filtration**

**Year: 2009**

**Descriptors:** ENGINEERING, MECHANICAL

**Descriptor Codes:** 0548; 0775

7/8/960 (Item 5 from file: 35)

Dissertation Abs Online

(c) 2009 ProQuest Info&Learning. All rights reserved.

02397618 ORDER NO: AADAA-I1460754

**Enhancement of photoactivity by synthesizing nanotube- nanoparticle composites of titanium dioxide and cadmium sulfide for generation of hydrogen via splitting of water**

**Year: 2008**

**Descriptors:** ENGINEERING, MATERIALS SCIENCE

**Descriptor Codes:** 0794

7/8/961 (Item 6 from file: 35)

Dissertation Abs Online

(c) 2009 ProQuest Info&Learning. All rights reserved.

02396550 ORDER NO: AADAA-I1460062

**Titanium dioxide/epoxy nanocomposites: Effects of ultrasonic processing and particle shapes**

**Year: 2008**

**Descriptors:** PHYSICS, CONDENSED MATTER

**Descriptor Codes:** 0611

7/8/963 (Item 8 from file: 35)

## Appendix A-5. Irrelevant Titles

Dissertation Abs Online

(c) 2009 ProQuest Info&Learning. All rights reserved.

02383139 ORDER NO: AADAA-I3331098

**Synthesizing mixed phase titania nanocomposites with enhanced photoactivity and redshifted photoresponse by reactive DC magnetron sputtering**

**Year: 2008**

**Descriptors:** ENGINEERING, MATERIALS SCIENCE

**Descriptor Codes:** 0775; 0794

7/8/965 (Item 10 from file: 35)

Dissertation Abs Online

(c) 2009 ProQuest Info&Learning. All rights reserved.

02371777 ORDER NO: AADAA-IC829726

**Functional one-dimensional nanostructures of silicon oxide, titanium dioxide and platinum**

**Year: 2007**

**Descriptors:** CHEMISTRY, INORGANIC

**Descriptor Codes:** 0488

7/8/966 (Item 11 from file: 35)

Dissertation Abs Online

(c) 2009 ProQuest Info&Learning. All rights reserved.

02369743 ORDER NO: AADAA-I1445888

**The antibacterial properties of brookite phase titanium dioxide nanoparticles against methicillin-resistant Staphylococcus aureus**

**Year: 2007**

**Descriptors:** BIOLOGY, MICROBIOLOGY

**Descriptor Codes:** 0410

7/8/967 (Item 12 from file: 35)

Dissertation Abs Online

(c) 2009 ProQuest Info&Learning. All rights reserved.

02366625 ORDER NO: AADAA-I3280756

**Polydiacetylene/titania nanocomposites for dye-sensitized photovoltaic applications**

**Year: 2007**

**Descriptors:** CHEMISTRY, POLYMER ; ENERGY ; ENGINEERING, MATERIALS SCIENCE

**Descriptor Codes:** 0495; 0791; 0794

7/8/968 (Item 13 from file: 35)

Dissertation Abs Online

(c) 2009 ProQuest Info&Learning. All rights reserved.

## Appendix A-5. Irrelevant Titles

02351009 ORDER NO: AADAA-I1447622

**Hydroxyapatite deposition onto nanoporous titanium dioxide and assessment of bone cell growth and proliferation**

**Year: 2008**

**Descriptors:** ENGINEERING, BIOMEDICAL

**Descriptor Codes:** 0541

7/8/969 (Item 14 from file: 35)

Dissertation Abs Online

(c) 2009 ProQuest Info&Learning. All rights reserved.

02343321 ORDER NO: AADAA-I3292210

**Fabrication and application of tin oxide doped titanium dioxide nanofibers, lead sulfide QDS doped titanium dioxide nanotubes, silver vanadium oxide nanowires**

**Year: 2007**

**Descriptors:** CHEMISTRY, INORGANIC

**Descriptor Codes:** 0488

7/8/971 (Item 16 from file: 35)

Dissertation Abs Online

(c) 2009 ProQuest Info&Learning. All rights reserved.

02337350 ORDER NO: AADAA-I1457133

**Nanotoxicology: From nano titanium dioxide particle size effect on Ceriodaphnia dubia to death mechanism**

**Year: 2008**

**Descriptor Codes:** 0775

7/8/972 (Item 17 from file: 35)

Dissertation Abs Online

(c) 2009 ProQuest Info&Learning. All rights reserved.

02337341 ORDER NO: AADAA-I1457124

**Interactions between titanium dioxide nanoparticles and algal cells at moderate particle concentration**

**Year: 2008**

**Descriptor Codes:** 0775

7/8/973 (Item 18 from file: 35)

Dissertation Abs Online

(c) 2009 ProQuest Info&Learning. All rights reserved.

02330965 ORDER NO: AADAA-I3316240

**NMR studies of complex carbon-containing materials: Maillard reaction products, soil, nanodiamond, and carbon modified titanium dioxide**

**Year: 2008**

## Appendix A-5. Irrelevant Titles

**Descriptors:** CHEMISTRY, ANALYTICAL

**Descriptor Codes:** 0486

7/8/974 (Item 19 from file: 35)

Dissertation Abs Online

(c) 2009 ProQuest Info&Learning. All rights reserved.

02329931 ORDER NO: AADAA-I3316382

**Ordered titanium dioxide nanotubular arrays: Synthesis, characterization and photoelectrochemical behavior**

**Year: 2008**

**Descriptors:** ENGINEERING, METALLURGY ; ENERGY ; ENGINEERING, MATERIALS SCIENCE

**Descriptor Codes:** 0743; 0791; 0794

7/8/975 (Item 20 from file: 35)

Dissertation Abs Online

(c) 2009 ProQuest Info&Learning. All rights reserved.

02323571 ORDER NO: AADAA-I3323526

**Zeolite-based nanosized titanium dioxide photocatalytic paper for antimicrobial barrier and toxin passivation in packaging: Design, synthesis and characterization**

**Year: 2008**

**Descriptors:** ENGINEERING, CHEMICAL ; ENGINEERING, PACKAGING

**Descriptor Codes:** 0542; 0549

7/8/976 (Item 21 from file: 35)

Dissertation Abs Online

(c) 2009 ProQuest Info&Learning. All rights reserved.

02322090 ORDER NO: AADAA-I3319475

**Processing, microstructure, and mechanical behavior of titanium dioxide nanotubes**

**Year: 2008**

**Descriptors:** ENGINEERING, MATERIALS SCIENCE

**Descriptor Codes:** 0794

7/8/977 (Item 22 from file: 35)

Dissertation Abs Online

(c) 2009 ProQuest Info&Learning. All rights reserved.

02302666 ORDER NO: AADAA-I3304422

**Synthesis and applications of titania nanotubes: Drug delivery and ionomer composites**

**Year: 2008**

**Descriptors:** ENGINEERING, BIOMEDICAL ; ENGINEERING, MATERIALS SCIENCE

**Descriptor Codes:** 0541; 0794

## Appendix A-5. Irrelevant Titles

7/8/978 (Item 23 from file: 35)

Dissertation Abs Online

(c) 2009 ProQuest Info&Learning. All rights reserved.

02251975 ORDER NO: AADAA-IMR31860

**Synthesis, characterization and photocatalytic application of titanium dioxide nanosized particles**

**Year: 2007**

**Descriptor Codes: 0775**

7/8/979 (Item 24 from file: 35)

Dissertation Abs Online

(c) 2009 ProQuest Info&Learning. All rights reserved.

02246302 ORDER NO: AADAA-I3283640

**Raman spectroscopy on the nanoscale: An investigation of silver triangle arrays, polymer laminates and gold-loaded mesoporous titania films**

**Year: 2007**

**Descriptors: CHEMISTRY, INORGANIC ; CHEMISTRY, PHYSICAL**

**Descriptor Codes: 0488; 0494**

7/8/981 (Item 26 from file: 35)

Dissertation Abs Online

(c) 2009 ProQuest Info&Learning. All rights reserved.

02215848 ORDER NO: AADAA-I3264427

**Novel preparation of nanostructured titanium dioxide photocatalytic particles, films, membranes, and devices for environmental applications**

**Year: 2007**

**Descriptors: ENGINEERING, SANITARY AND MUNICIPAL ; ENVIRONMENTAL SCIENCES**

**Descriptor Codes: 0554; 0768; 0775**

7/8/982 (Item 27 from file: 35)

Dissertation Abs Online

(c) 2009 ProQuest Info&Learning. All rights reserved.

02208488 ORDER NO: AADAA-I3252598

**Multi-functional porous mix-valent manganese oxide nano-materials and ruthenium/titanium dioxide for magnetic, electronic, and catalytic applications**

**Year: 2006**

**Descriptors: CHEMISTRY, INORGANIC ; ENGINEERING, CHEMICAL ; ENGINEERING, MATERIALS SCIENCE**

**Descriptor Codes: 0488; 0542; 0794**

## Appendix A-5. Irrelevant Titles

7/8/983 (Item 28 from file: 35)

Dissertation Abs Online

(c) 2009 ProQuest Info&Learning. All rights reserved.

02202112 ORDER NO: AADAA-I1440608

**Manufacturing and performance of titanium dioxide -ultra high molecular weight polyethylene nanocomposite materials**

**Year: 2007**

**Descriptors:** ENGINEERING, MECHANICAL

**Descriptor Codes:** 0548

7/8/984 (Item 29 from file: 35)

Dissertation Abs Online

(c) 2009 ProQuest Info&Learning. All rights reserved.

02191185 ORDER NO: AADAA-I3243305

**Reactions of heme catalysts at nanocrystalline titanium dioxide thin film interfaces with organohalide pollutants**

**Year: 2007**

**Descriptors:** CHEMISTRY, INORGANIC ; ENVIRONMENTAL SCIENCES

**Descriptor Codes:** 0488; 0768; 0775

7/8/985 (Item 30 from file: 35)

Dissertation Abs Online

(c) 2009 ProQuest Info&Learning. All rights reserved.

02161988 ORDER NO: AADAA-I3224608

**Titania carbon nanotube composites for enhanced photocatalysis**

**Year: 2006**

**Descriptors:** ENGINEERING, MATERIALS SCIENCE

**Descriptor Codes:** 0794

7/8/986 (Item 31 from file: 35)

Dissertation Abs Online

(c) 2009 ProQuest Info&Learning. All rights reserved.

02161298 ORDER NO: AADAA-I3222857

**Nanoparticle titanium dioxide aqueous interfacial energy can be modified to control phase stability, coarsening, and morphology**

**Year: 2006**

**Descriptors:** ENGINEERING, MATERIALS SCIENCE

**Descriptor Codes:** 0794

7/8/988 (Item 33 from file: 35)

Dissertation Abs Online

## Appendix A-5. Irrelevant Titles

(c) 2009 ProQuest Info&Learning. All rights reserved.  
02156707 ORDER NO: AADAA-IMR16317

**Synthesis, characterization and photoconductivity behavior of inverted nanocrystalline titania and nanocrystalline titania-silica photonic crystals**

**Year: 2006**

**Descriptors:** CHEMISTRY, PHYSICAL

**Descriptor Codes:** 0494

7/8/989 (Item 34 from file: 35)

Dissertation Abs Online

(c) 2009 ProQuest Info&Learning. All rights reserved.  
02155935 ORDER NO: AADAA-I1436015

**Growth of carbon nanotubes on nanotubular titanium dioxide template and electrochemical hydrogen storage thereof**

**Year: 2006**

**Descriptors:** ENGINEERING, METALLURGY ; ENERGY

**Descriptor Codes:** 0743; 0791

7/8/990 (Item 35 from file: 35)

Dissertation Abs Online

(c) 2009 ProQuest Info&Learning. All rights reserved.  
02148148 ORDER NO: AADAA-I1433878

**Photocatalytic degradation of 2,4-dinitrophenol using nanosized titanium dioxide colloidal particles**

**Year: 2005**

**Descriptors:** ENGINEERING, CHEMICAL

**Descriptor Codes:** 0542

7/8/991 (Item 36 from file: 35)

Dissertation Abs Online

(c) 2009 ProQuest Info&Learning. All rights reserved.  
02134042 ORDER NO: AADAA-I3207209

**Furnace aerosol reactor (FuAR) synthesis, characterization and study of collisional-sintering growth of nanostructured pristine and doped titanium dioxide particles**

**Year: 2005**

**Descriptors:** ENGINEERING, CHEMICAL ; ENGINEERING, MECHANICAL

**Descriptor Codes:** 0775; 0542; 0548

## Appendix A-5. Irrelevant Titles

7/8/992 (Item 37 from file: 35)

Dissertation Abs Online

(c) 2009 ProQuest Info&Learning. All rights reserved.

02129326 ORDER NO: AADAA-I3203225

**Functionalized porous titania nanostructures as efficient photocatalysts**

**Year: 2005**

**Descriptors:** CHEMISTRY, PHYSICAL ; ENGINEERING, MATERIALS SCIENCE

**Descriptor Codes:** 0494; 0794

7/8/993 (Item 38 from file: 35)

Dissertation Abs Online

(c) 2009 ProQuest Info&Learning. All rights reserved.

02119890 ORDER NO: AADAA-I3192271

**RF pulsed plasma surface modification of titanium dioxide nanoparticles for environmental applications**

**Year: 2005**

**Descriptors:** ENVIRONMENTAL SCIENCES

**Descriptor Codes:** 0768; 0775

7/8/994 (Item 39 from file: 35)

Dissertation Abs Online

(c) 2009 ProQuest Info&Learning. All rights reserved.

02102593 ORDER NO: AADAA-I3183417

**Titanium dioxide thin films: Understanding nanoscale oxide heteroepitaxy for silicon-based applications**

**Year: 2005**

**Descriptors:** PHYSICS, CONDENSED MATTER

**Descriptor Codes:** 0611

7/8/995 (Item 40 from file: 35)

Dissertation Abs Online

(c) 2009 ProQuest Info&Learning. All rights reserved.

02094197 ORDER NO: AADAA-I3178755

**Integration of nanostructured titania into microsystems**

**Year: 2005**

**Descriptors:** ENGINEERING, MATERIALS SCIENCE

**Descriptor Codes:** 0794

7/8/996 (Item 41 from file: 35)

Dissertation Abs Online

(c) 2009 ProQuest Info&Learning. All rights reserved.

## Appendix A-5. Irrelevant Titles

02091161 ORDER NO: AADAA-I3176888

**Oriented arrays of single-crystal titanium dioxide nanofibers by gas-phase etching:  
Processing and characterization**

**Year: 2005**

**Descriptors:** ENGINEERING, MATERIALS SCIENCE

**Descriptor Codes:** 0794

7/8/997 (Item 42 from file: 35)

Dissertation Abs Online

(c) 2009 ProQuest Info&Learning. All rights reserved.

02074213 ORDER NO: AADAA-IC820587

**Photoinduced dynamics of Ru(dcbpy)<sub>2</sub>(NCS)<sub>2</sub>: In solution and on nanocrystalline titanium dioxide thin films**

**Year: 2004**

**Descriptors:** CHEMISTRY, PHYSICAL

**Descriptor Codes:** 0494

7/8/998 (Item 43 from file: 35)

Dissertation Abs Online

(c) 2009 ProQuest Info&Learning. All rights reserved.

02057481 ORDER NO: AADAA-I3158830

**Photocatalytic nanocomposites based on titania and carbon nanotubes**

**Year: 2004**

**Descriptors:** ENGINEERING, MATERIALS SCIENCE

**Descriptor Codes:** 0794; 0775

7/8/999 (Item 44 from file: 35)

Dissertation Abs Online

(c) 2009 ProQuest Info&Learning. All rights reserved.

02046842 ORDER NO: AADAA-I3151377

**Kinetics and thermodynamics of dye (group VIII metal)-sensitized nanocrystalline titanium dioxide photoelectrodes**

**Year: 2004**

**Descriptors:** CHEMISTRY, INORGANIC

**Descriptor Codes:** 0488

7/8/1000 (Item 45 from file: 35)

Dissertation Abs Online

(c) 2009 ProQuest Info&Learning. All rights reserved.

02046303 ORDER NO: AADAA-I3150929

**Model catalyst studies of the carbon monoxide oxidation reaction on titania supported gold nanoclusters**

## Appendix A-5. Irrelevant Titles

**Year: 2004**

**Descriptors:** ENGINEERING, CHEMICAL

**Descriptor Codes:** 0542

7/8/1001 (Item 46 from file: 35)

Dissertation Abs Online

(c) 2009 ProQuest Info&Learning. All rights reserved.

02042209 ORDER NO: AADAA-I3148791

**Rigid-rod sensitizers for functionalization of titanium dioxide nanoparticles**

**Year: 2004**

**Descriptors:** CHEMISTRY, ORGANIC ; ENERGY

**Descriptor Codes:** 0490; 0791

7/8/1002 (Item 47 from file: 35)

Dissertation Abs Online

(c) 2009 ProQuest Info&Learning. All rights reserved.

02024543 ORDER NO: AADAA-I0806741

**Preparation and characterization of sol-gel derived peroxo titania and its application for nano-crystalline dye sensitized solar cell**

**Year: 2003**

**Descriptors:** ENGINEERING, CHEMICAL ; ENERGY

**Descriptor Codes:** 0542; 0791

7/8/1003 (Item 48 from file: 35)

Dissertation Abs Online

(c) 2009 ProQuest Info&Learning. All rights reserved.

02011528 ORDER NO: AADAA-I3128386

**Surface reactions on stoichiometric and defective titanium dioxide: From single crystals to nanoparticles**

**Year: 2004**

**Descriptors:** CHEMISTRY, PHYSICAL ; ENGINEERING, CHEMICAL

**Descriptor Codes:** 0494; 0542

7/8/1004 (Item 49 from file: 35)

Dissertation Abs Online

(c) 2009 ProQuest Info&Learning. All rights reserved.

01977082 ORDER NO: AADAA-I3107522

**Charge separation and recombination in dye-sensitized nanocrystalline titanium dioxide films**

**Year: 2004**

**Descriptors:** CHEMISTRY, INORGANIC ; PHYSICS, CONDENSED MATTER

## Appendix A-5. Irrelevant Titles

**Descriptor Codes:** 0488; 0611

7/8/1006 (Item 51 from file: 35)

Dissertation Abs Online

(c) 2009 ProQuest Info&Learning. All rights reserved.

01928087 ORDER NO: AADAA-I3076699

**Microstructure investigation of plasma sprayed alumina 13 weight percent titania coatings from nanocrystalline feed powders**

**Year: 2002**

**Descriptors:** ENGINEERING, MATERIALS SCIENCE

**Descriptor Codes:** 0794

7/8/1007 (Item 52 from file: 35)

Dissertation Abs Online

(c) 2009 ProQuest Info&Learning. All rights reserved.

01836443 ORDER NO: AADAA-I3014921

**The synthesis and characterization of nanostructured titanium dioxide photocatalysts and their performance in selected environmental and industrial applications**

**Year: 2001**

**Descriptors:** ENGINEERING, CHEMICAL

**Descriptor Codes:** 0775; 0542

7/8/1008 (Item 53 from file: 35)

Dissertation Abs Online

(c) 2009 ProQuest Info&Learning. All rights reserved.

01825651 ORDER NO: AADAA-I3007802

**Oxidations of organic substrates by ruthenium oxo complexes on nanocrystalline thin films of titanium dioxide**

**Year: 2001**

**Descriptors:** CHEMISTRY, INORGANIC ; ENGINEERING, MATERIALS SCIENCE

**Descriptor Codes:** 0488; 0794

7/8/1009 (Item 1 from file: 36)

MetalBase

(c) 2010 The Thomson Corporation. All rights reserved.

0004975402 IP Accession No.: 09-0306596

**The photostability of wool doped with photocatalytic titanium dioxide nanoparticles 2009**

**Descriptors:** Photochemical stability; Wool; Chemical treatment; Inorganic pigment-ACT; Titanium IV Oxides-ACT; Nanocrystal-ACT; Chemiluminescence; Photochemical degradation; Ultraviolet absorbent; Yellowing; Kinetics; Experimental study ; Natural fiber; Animal fiber; Additive; Stabilizer agent; Artificial ageing; Stabilite photochimique; Laine;

## Appendix A-5. Irrelevant Titles

Traitement chimique; Pigment mineral-ACT; Titane IV Oxyde-ACT; Nanocristal-ACT; Chimiluminescence; Degradation photochimique; Absorbant UV; Jaunissement; Cinetique; Etude experimentale; Fibre naturelle; Fibre animale; Additif; Stabilisant; Vieillissement accelere; Degradation photooxydante; Vieillissement photochimique; Stabilisation photochimique; Estabilidad fotoquimica; Lana; Tratamiento quimico; Pigmento inorganico-ACT; Titanio IV Oxido-ACT; Nanocristal-ACT; Quimioluminiscencia; Degradacion fotoquimica; Absorbente UV; Amarilleo; Cinetica; Estudio experimental; Fibra natural; Fibra animal; Aditivo; Estabilizante; Envejecimiento acelerado  
PASC

7/8/1010 (Item 2 from file: 36)

MetalBase

(c) 2010 The Thomson Corporation. All rights reserved.

0004967917 IP Accession No.: 09-0285776

**Separation and preconcentration of trace indium(III) from environmental samples with nanometer-size titanium dioxide**

**2009**

**Descriptors:** Separation; Titanium oxide; Hydrometallurgy; Separation; Oxyde de titane; Hydrometallurgie; Separacion; Titanio oxido; Hidrometalurgia; Titanoxid; Hydrometallurgie  
PASC

7/8/1011 (Item 3 from file: 36)

MetalBase

(c) 2010 The Thomson Corporation. All rights reserved.

0004967509

**Study on the ohmic contact, electrical and optical properties of nanostructured titanium dioxide thin films**

**2009**

**Descriptors:** electrical conductivity; electrical resistivity; energy gap; infrared spectra; ohmic contacts; semiconductor thin films; sol-gel processing; titanium compounds; ultraviolet spectra; visible spectra

**Identifiers:** ohmic contact; nanostructured titanium dioxide thin films; sol-gel concentrations; sol-gel spin coating method; Advantest source meter; metal contact; sheet resistance; optical transmission spectra; UV-VIS-NIR spectrophotometer; band gap; wavelength 200 nm to 1000 nm; TiO<sub>2</sub>-Pt; TiO<sub>2</sub>-Au

INSP

7/8/1012 (Item 4 from file: 36)

MetalBase

(c) 2010 The Thomson Corporation. All rights reserved.

0004963776

**Nanomechanical characterization of microwave hydrothermally synthesized titania nanowires - art. no. 145105**

**2009**

## Appendix A-5. Irrelevant Titles

**Identifiers:** MECHANICAL-PROPERTIES; YOUNGS MODULUS; THIN-FILMS; SURFACE; NANOTUBES; DEPENDENCE; NANOBELTS; CATALYSTS; GROWTH; TIO<sub>2</sub>  
CURC

7/8/1013 (Item 5 from file: 36)

MetalBase

(c) 2010 The Thomson Corporation. All rights reserved.

0004930968 **IP Accession No.:** 09-0441870

### **Synthesis and properties of photosensitive polyimide-nanocrystalline titania optical thin films**

**2009**

**Descriptors:** Hybrid material; Polyimide; Fluorine containing polymer; Aromatic polymer; Functional polymer; Photoresist; Titanium oxide-SEC; Thin film; Preparation ; Polyaddition; Polyacid-ENT; Chemical modification; Esterification; Methacrylic acid esters-ENT; Sol gel **process**; Morphology; Dispersion degree; Optical absorption; Refraction index; Photolithography; Resolving power; Thermal stability; Experimental study; Materiau hybride; Imide polymere; Polymere fluor; Polymere aromatique; Polymere fonctionnel; Photoresist; Oxyde de titane-SEC; Couche mince; Preparation; Polyaddition; Acide polymere-ENT; Modification chimique; Esterification; Methacrylique acide ester-ENT; Procede sol gel; Morphologie; Degre dispersion; Absorption optique; Indice refraction; Photolithographie; Limite resolution; Stabilite thermique; Etude experimentale; Materiau a indice de refraction eleve; Material hibrido; Imida polimero; Polimero fluor; Polimero aromatico; Polimero funcional; Fotorresistencia; Titanio oxido-SEC; Capa fina; Preparacion; Poliadicion; Acido polimero-ENT; Modificacion quimica; Esterificacion; Procedimiento sol gel; Morfologia; Grado dispersion; Absorcion optica; Indice refraccion; Fotolitografia; Poder resolucion; Estabilidad termica; Estudio experimental; Optical properties; Propriete optique; Propiedad optica  
PASC

7/8/1014 (Item 6 from file: 36)

MetalBase

(c) 2010 The Thomson Corporation. All rights reserved.

0004914419 **IP Accession No.:** 09-0386080

### **Fabrication of Gold-Doped Titanium Dioxide (TiO<sub>2</sub>:Au) Nanofibers Photocatalyst by Vacuum Ion Sputter Coating**

**2009**

**Descriptors:** Nanocomposite; Nanofiber; Styrene copolymer; Methacrylic acid copolymer; Titanium oxide-SEC-ACT; Doped compound-SEC; Gold-SEC; Precursor; Catalyst; **Manufacturing:** Electrospinning; Sputter coating; Morphology; Thermal decomposition; Catalyst activity; Photocatalysis; Photolysis; Acetaldehyde-ENT; Experimental study; Nanocomposite; Nanofibre; Styrene copolymere; Methacrylique acide copolymere; Oxyde de titane-SEC-ACT; Compose dope-SEC; Or-SEC; Precurseur; Catalyseur; Fabrication;

## Appendix A-5. Irrelevant Titles

Electrofilage; Revetement pulverisation; Morphologie; Decomposition thermique; Activite catalytique; Photocatalyse; Photolyse; Acetaldehyde-ENT ; Etude experimentale; Fibre composite; Nanocompuesto; Nanofibra; Estireno copolimero; Metacrilico acido copolimero; Titanio oxido-SEC-ACT; Compuesto dopado-SEC; Oro-SEC; Precursor; Catalizador; Fabricacion; Electrohilado; Revestimiento pulverizacion; Morfologia; Descomposicion termica; Actividad catalitica; Fotocatalisis; Fotolisis; Acetaldehido-ENT; Estudio experimental  
PASC

7/8/1015 (Item 7 from file: 36)

MetalBase

(c) 2010 The Thomson Corporation. All rights reserved.

0004910049

### **Fractal character of titania nanoparticles formed by laser ablation - art. no. 054306 2009**

**Descriptors:** fractals ; laser ablation ; nanofabrication ; nanoparticles ; Raman spectra ; titanium compounds ; transmission electron microscopy ; X-ray diffraction

**Identifiers:** RAMAN-SCATTERING; TIO<sub>2</sub> NANOCRYSTALS; SIZE DISTRIBUTION; PHASE EXPLOSION; METAL COLLOIDS; TEMPERATURE; DIMENSION; CATALYSTS; SURFACE; FILMS

CURC

7/8/1016 (Item 8 from file: 36)

MetalBase

(c) 2010 The Thomson Corporation. All rights reserved.

0004907779

### **Efficient sintering of nanocrystalline titanium dioxide films for dye solar cells via raster scanning laser - art. no. 103312 2009**

**Descriptors:** laser beam applications ; nanostructured materials ; sintering ; solar cells ; thin films ; titanium compounds

**Identifiers:** TIO<sub>2</sub>

CURC

7/8/1017 (Item 9 from file: 36)

MetalBase

(c) 2010 The Thomson Corporation. All rights reserved.

0004886635 **IP Accession No.:** 08-0424976

### **Polymethylmethacrylate-Grafted Titanium Dioxide Nanoparticles Prepared via Radical Polymerization 2008**

**Descriptors:** Methyl methacrylate polymer; Titanium IV Oxides-SEC-SUB; Nanoparticle-SUB; Free radical polymerization; Composite particles; Coupling agent; Organic silane-ACT; Surface reaction; Graft polymers; Property **processing** relationship; Thermal stability;

## Appendix A-5. Irrelevant Titles

Structure **processing** relationship; Morphology; Experimental study; Composite material; Thermal properties; Methacrylate de methyle polymere; Titane IV Oxyde-SEC-SUB; Nanoparticule-SUB; Polymerisation radicalaire; Particule composite; Agent accrochage; Silane organique-ACT; Reaction surface; Polymere greffe; Relation mise en oeuvre propriete; Stabilite thermique; Relation mise en oeuvre structure; Morphologie; Etude experimentale; Materiau composite; Propriete thermique; Metacrilato de metilo polimero; Titanio IV Oxido-SEC-SUB; Nanoparticula-SUB; Polimerizacion radicalar; Agente enganche ; Silano organico-ACT; Reaccion superficie; Relacion puesta en marcha propiedad; Estabilidad termica; Relacion puesta en marcha estructura; Morfologia; Estudio experimental; Material compuesto; Propiedad termica  
PASC

7/8/1018 (Item 10 from file: 36)

MetalBase

(c) 2010 The Thomson Corporation. All rights reserved.

0004876567

**Effect of process parameters on the chemical vapour synthesis of nanocrystalline titania - art. no. 155313**

**2008**

**Identifiers:** THERMODYNAMIC ANALYSIS; TIO<sub>2</sub>; NANOPARTICLE; TEMPERATURE; POWDERS; REACTOR; FILMS

CURC

7/8/1019 (Item 11 from file: 36)

MetalBase

(c) 2010 The Thomson Corporation. All rights reserved.

0004874001 **IP Accession No.:** 08-0340557

**Precipitation of nanosized titanium dioxide from aqueous titanium (IV) chloride solutions by neutralization with MgO**

**2008**

**Descriptors:** Microstructure; Precipitation; **Aqueous** solution; Chlorides; Magnesium oxide; Recovery; Hydrometallurgy; Microstructure; Precipitation; Solution aqueuse; Chlorure; Oxyde de magnesium; Recuperation; Hydrometallurgie; Microestructura; Precipitacion; Solucion acuosa; Cloruro; Magnesio oxido; Recuperacion; Hidrometalurgia; Mikrogefuege; Ausscheidung; Waessrige Loesung; Chlorid; Magnesiumoxid; Hydrometallurgie

PASC

7/8/1020 (Item 12 from file: 36)

MetalBase

(c) 2010 The Thomson Corporation. All rights reserved.

0004866933

**Silica/titania-coated Y<sub>2</sub>O<sub>3</sub> : Tm<sup>3+</sup>, Yb<sup>3+</sup> nanoparticles with improvement in upconversion luminescence induced by different thickness shells - art. no. 123533**

**2008**

## Appendix A-5. Irrelevant Titles

**Identifiers:** RESOLVED FLUOROMETRIC APPLICATION; RARE-EARTH IONS; SOL-GEL; SURFACE MODIFICATION; NANOCRYSTALS; CORE; MONODISPERSE; FLUORESCENCE; SPECTROSCOPY; PARTICLES  
CURC

7/8/1021 (Item 13 from file: 36)

MetalBase

(c) 2010 The Thomson Corporation. All rights reserved.

0004856176

**Interesting magnetic behavior from reduced titanium dioxide nanobelts - art. no. 232502**

**2008**

**Identifiers:** TIO<sub>2</sub>; FERROMAGNETISM; NANOTUBES; ESR  
CURC

7/8/1022 (Item 14 from file: 36)

MetalBase

(c) 2010 The Thomson Corporation. All rights reserved.

0004854757

**Titania-germanium nanocomposite for photo-thermo-electric application - art. no. 265701**

**2008**

**Identifiers:** SMALL SEMICONDUCTOR CRYSTALLITES; ANATASE-RUTILE TRANSFORMATION; QUANTUM-DOT SUPERLATTICES; PHASE-TRANSFORMATION; SOLAR-CELL; VISIBLE PHOTOLUMINESCENCE; TIO<sub>2</sub> NANOPARTICLES; GE MICROCRYSTALS; RAMAN; CONDUCTIVITY  
CURC

7/8/1023 (Item 15 from file: 36)

MetalBase

(c) 2010 The Thomson Corporation. All rights reserved.

0004839783

**Preparation and capacitance behavior of nickel oxide-titania nanocomposite 2007**

**Descriptors:** anodisation; capacitance; electrochemical electrodes; electrodeposition; field emission electron microscopy; heat treatment; nanocomposites; nanotubes; nickel compounds; oxidation; reduction (chemical); scanning electron microscopy; titanium compounds; voltammetry (chemical analysis); X-ray chemical analysis; X-ray diffraction

**Identifiers:** electrochemical capacitance behavior; nickel oxide-titania nanocomposite; titania nanotube array; potentiostatic anodization; titanium metal sheet; electrodeposition; electrooxidation; heating treatment processes; microstructure; field emission scanning electron microscopy; FESEM; X-ray diffraction; XRD; energy dispersive X-ray analysis; EDX; functional electrode; cyclic voltammetry; redox peaks; sodium hydroxide aqueous solution; supercapacitance; size 110 nm; size 700 nm; Ni-TiO<sub>2</sub>/Ti; Ti

## Appendix A-5. Irrelevant Titles

INSP

7/8/1024 (Item 16 from file: 36)

MetalBase

(c) 2010 The Thomson Corporation. All rights reserved.

0004834476

**Electrochemical fabrication of Sn nanowires on titania nanotube guide layers - art. no. 205601**

**2008**

**Identifiers:** ONE-DIMENSIONAL NANOSTRUCTURES; TIO<sub>2</sub> NANOTUBES; TEMPLATE; FILMS; ANODIZATION; NANORODS; GROWTH; ARRAYS  
CURC

7/8/1025 (Item 17 from file: 36)

MetalBase

(c) 2010 The Thomson Corporation. All rights reserved.

0004824998

**Hybrid titanium dioxide/PS-b-PEO block copolymer nanocomposites based on sol-gel synthesis - art. no. 155607**

**2008**

**Identifiers:** SEMICONDUCTOR-POLYMER COMPOSITES; DIBLOCK COPOLYMER; TIO<sub>2</sub> NANOPARTICLES; NANOCRYSTALLINE TITANIA; SIZE CONTROL; FILMS; ANATASE; FABRICATION; SIMULATION; IONOMERS  
CURC

7/8/1026 (Item 18 from file: 36)

MetalBase

(c) 2010 The Thomson Corporation. All rights reserved.

0004824944

**Synthesis and performance of novel magnetically separable nanospheres of titanium dioxide photocatalyst with egg-like structure - art. no. 095606**

**2008**

**Identifiers:** SOL-GEL; NICKEL FERRITE; TIO<sub>2</sub>; DEGRADATION; WATER; NANOPARTICLES; PARTICLES ; DESIGN; OXIDES  
CURC

7/8/1027 (Item 19 from file: 36)

MetalBase

(c) 2010 The Thomson Corporation. All rights reserved.

0004824942

**Growth mechanism of titanium dioxide nanowires for dye-sensitized solar cells - art. no. 095604**

## Appendix A-5. Irrelevant Titles

**2008**

**Identifiers:** NANOCRYSTALLINE TIO<sub>2</sub> FILMS; HYDROTHERMAL SYNTHESIS; PHOTOELECTROCHEMICAL PROPERTIES; NANOTUBES; TITANATE; ARRAYS; NANORODS; PERFORMANCE; TRANSPORT  
CURC

7/8/1028 (Item 20 from file: 36)

MetalBase

(c) 2010 The Thomson Corporation. All rights reserved.

0004812357

**Characterization of silver nanoparticles synthesized on titanium dioxide fine particles - art. no. 065711**

**2008**

**Identifiers:** TIO<sub>2</sub> THIN-FILM; PHOTOCATALYTIC DEGRADATION; AQUEOUS SUSPENSIONS; OPTICAL-PROPERTIES; BACTERIAL; SURFACES; LIGHT  
CURC

7/8/1029 (Item 21 from file: 36)

MetalBase

(c) 2010 The Thomson Corporation. All rights reserved.

0004779974

**Nanostructured titania/hydroxyapatite composite coatings deposited by high velocity oxy-fuel (HVOF) spraying**

**2007**

**Descriptors:** biomedical materials; calcium compounds; nanocomposites; particle size; porosity; spray coatings; surface roughness; thermal spraying; thin films; titanium compounds; Vickers hardness; X-ray diffraction

**Identifiers:** TiAlV; TiO<sub>2</sub>/Ca<sub>10</sub>(PO<sub>4</sub>)<sub>6</sub>(OH)<sub>2</sub>-TiAlV; bioactive phase; chemical stability; thermal sprayed coatings; spray process; chemical reaction; XRD; X-ray diffraction; bond strength; Vickers hardness; surface roughness; porosity; microstructures; coating properties; spray jet ; particle size distributions; feedstock powders; HA powders; HVOF-sprayed coatings; high velocity oxy-fuel spraying; nanostructured titania-hydroxyapatite composite coatings

INSP

7/8/1030 (Item 22 from file: 36)

MetalBase

(c) 2010 The Thomson Corporation. All rights reserved.

0004758238

**Formation and photopatterning of nanoporous titania thin films - art. no. 233102**

**2007**

**Identifiers:** TIO<sub>2</sub>; ANATASE; OXIDES; COMPOSITES; SILICA

## Appendix A-5. Irrelevant Titles

CURC

7/8/1031 (Item 23 from file: 36)

MetalBase

(c) 2010 The Thomson Corporation. All rights reserved.

0004758036 IP Accession No.: 07-0331026

**Preparation and characterization of poly(imide siloxane) (PIS)/ titania(TiO SUB 2 ) hybrid nanocomposites by sol-gel processes  
2007**

**Descriptors:** Nanocomposite; Hybrid material; Imide copolymer; Siloxane copolymer; Dimethylsiloxane copolymer; Titanium oxide-SEC; Preparation; Polyaddition; Sol gel process; Morphology; Dispersion degree; Molecular structure; Optical absorption; Tensile property; Thermal stability; Concentration effect; Experimental study; Nanocomposite; Materiau hybride; Imide copolymere; Siloxane copolymere; Siloxane(dimethyl) copolymere; Titane oxyde-SEC; Preparation; Polyaddition; Procede sol gel; Morphologie; Degre dispersion; Structure moleculaire; Absorption optique; Propriete traction; Stabilite thermique; Effet concentration; Etude experimentale; Copolymere titane; Siloxane(diphenyl) copolymere; Nanocompuesto; Material hibrido; Imida copolimero; Siloxano copolimero; Siloxano(dimetil) copolimero; Titanio oxido-SEC; Preparacion; Poliadicion; Procedimiento sol gel; Morfologia; Grado dispersion; Estructura molecular; Absorcion optica; Propiedad traccion; Estabilidad termica; Efecto concentracion; Estudio experimental; Optical properties Mechanical properties; Propriete optique Propriete mecanique; Propiedad optica Propiedad mecanica  
PASC

7/8/1032 (Item 24 from file: 36)

MetalBase

(c) 2010 The Thomson Corporation. All rights reserved.

0004753114

**Preparation of cobalt-titanium dioxide nanocomposite films by combining inverse micelle method and plasma treatment  
2007**

**Descriptors:** cobalt compounds; colloids; nanocomposites; plasma materials processing; thin films; titanium compounds  
**Identifiers:** nanocomposite films; inverse micelle method; plasma treatment; metal nanogranular thin film; colloidal wet process; dry process; plasma processing; CoTiO  
INSP

7/8/1033 (Item 25 from file: 36)

MetalBase

(c) 2010 The Thomson Corporation. All rights reserved.

0004731184 IP Accession No.: 229166

## Appendix A-5. Irrelevant Titles

### **Spraying of agglomerated TiO<sub>2</sub> [titania] nanopowder by water-stabilised plasma. 2006**

**Descriptors:** CONFERENCES; PLASMA SPRAYING; SPRAYED COATINGS; POWDER; CERAMIC COATINGS; OXIDE COATINGS; TITANIA; **PROCESS** PROCEDURES; PARTICLE SIZE; MICROSTRUCTURE; ELASTICITY; HARDNESS; STABILITY; **PROCESS** PARAMETERS; POROSITY; COMPOSITION; CONFERENCES; DEFECTS; CAVITIES; **PROCESS** CONDITIONS; MECHANICAL PROPERTIES; PARTICLES; OXIDES; CERAMICS; COATINGS; NONMETALLIC COATINGS; COATING METHODS; SPRAYING WELD

7/8/1034 (Item 26 from file: 36)

MetalBase

(c) 2010 The Thomson Corporation. All rights reserved.

0004730360 **IP Accession No.:** 07-0417998

### **Preparation of titanium dioxide/polyacrylate nanocomposites by sol-gel process in reverse micelles and in situ photopolymerization 2006**

**Descriptors:** Preparation; Acrylate polymer; Nanocomposite; Sol gel **process**; Reverse micelle; Photopolymerization; Hybrid material; Polyfunctional compound-ENT; Crosslinked polymer; Refraction index; Titanium oxide-SEC; Successive reaction; Property **processing** relationship; Roughness; Heat treatment; Experimental study; Composite material; Optical properties; Surface properties; Preparation; Acrylate polymere; Nanocomposite; Procède sol gel; Micelle inverse; Polymerisation photochimique; Materiau hybride; Compose polyfonctionnel-ENT; Polymere reticule; Indice refraction; Titane oxyde-SEC; Reaction successive; Relation mise en oeuvre propriete; Rugosite ; Traitement thermique; Etude experimentale; Materiau composite; Propriete optique; Propriete surface; Preparacion; Acrilato polimero; Nanocompuesto; Procedimiento sol gel; Micela inversa; Polimerizacion fotoquimica; Material hibrido; Compuesto polifuncional-ENT; Polimero reticulado; Indice refraccion; Titanio oxido-SEC; Reaccion consecutiva; Relacion puesta en marcha propiedad; Rugosidad; Tratamiento termico; Estudio experimental; Material compuesto; Propiedad optica; Propiedad superficie PASC

7/8/1035 (Item 27 from file: 36)

MetalBase

(c) 2010 The Thomson Corporation. All rights reserved.

0004726932 **IP Accession No.:** 07-0260982

### **4,4'-bismaleimidodiphenyl methane modified novolak resin/titania nanocomposites : Preparation and properties 2006**

**Descriptors:** Nanocomposite; Preparation; Sol gel **process**; Titanates-ENT; Novolac; Thermal stability; Thermal properties; Polymer blends; Bismaleimide resin; Titanium oxide-SEC; Curing(plastics); Allyl resin; Structure **processing** relationship; Morphology; Property **processing** relationship; Dynamic mechanical properties; Dispersion reinforced material ;

## Appendix A-5. Irrelevant Titles

Experimental study; Composite material; Phenoplasts; Nanocomposite; Preparation; Procédé sol gel; Titanate-ENT; Novolaque; Stabilité thermique; Propriété thermique; Mélange polymère; Bismaleimide résine; Titane oxyde-SEC; Durcissement(matière plastique); Allylique dérivé polymère; Relation mise en œuvre structure; Morphologie; Relation mise en œuvre propriété; Propriété dynamomécanique; Matériau renforcé dispersion; Étude expérimentale; Matériau composite; Phenoplaste; Nanocompuesto; Preparación; Procedimiento sol gel; Titanato-ENT; Novolaca; Estabilidad térmica; Propiedad térmica; Bismaleimida resina; Titanio óxido-SEC; Endurecimiento(material plástico); Alílico derivado polímero; Relación puesta en marcha estructura; Morfología; Relación puesta en marcha propiedad; Propiedad dinamomécanica; Material reforzado dispersion; Estudio experimental; Material compuesto; Fenoplasto  
PASC

7/8/1036 (Item 28 from file: 36)

MetalBase

(c) 2010 The Thomson Corporation. All rights reserved.

0004726538 IP Accession No.: 07-0248096

**Structure and properties of composite films prepared from cellulose and nanocrystalline titanium dioxide particles**

**2006**

**Descriptors:** Nanocomposite; Cellulose; Titanium oxide-SEC; Morphology; Antibacterial agent; Bactericidal effect; Nanocrystal-SEC; Tensile strength; **Manufacturing;** Growth from solution; Structure **processing** relationship; Concentration effect; Property **processing** relationship ; Thermal stability; Dispersion reinforced material; Optical properties; Experimental study; Biological properties; Thermal properties; Mechanical properties; Composite material; Nanocomposite; Cellulose; Titane oxyde-SEC; Morphologie; Antibacterien; Bactericidie; Nanocrystal-SEC; Resistance traction; Fabrication; Methode en solution; Relation mise en œuvre structure; Effet concentration; Relation mise en œuvre propriété; Stabilité thermique; Matériau renforcé dispersion; Propriété optique; Étude expérimentale; Propriété biologique; Propriété thermique; Propriété mécanique; Matériau composite; Nanocompuesto; Celulosa; Titanio óxido-SEC; Morfología; Antibacteriano; Bactericidia; Nanocrystal-SEC; Resistencia tracción; Fabricación; Metodo en solución; Relación puesta en marcha estructura; Efecto concentración; Relación puesta en marcha propiedad; Estabilidad térmica; Material reforzado dispersion; Propiedad óptica; Estudio experimental; Propiedad biológica; Propiedad térmica; Propiedad mecánica; Material compuesto

PASC

7/8/1037 (Item 29 from file: 36)

MetalBase

(c) 2010 The Thomson Corporation. All rights reserved.

0004724818 IP Accession No.: 07-0176277

**Photo-differential scanning calorimetry where science meets business study on photopolymerization of nanosized titanium dioxide /polyacrylate hybrid materials**

**2006**

## Appendix A-5. Irrelevant Titles

**Descriptors:** Photopolymerization; Acrylate polymer; Hybrid material; Titanium oxide-SEC; Reverse micelle; Transparent material; Kinetics; Sol gel **process**; Nanocomposite; Titanates-ENT; Crosslinked polymer; Structure **processing** relationship; Morphology; Dispersion degree; Reaction mechanism; Experimental study; Composite material; Polymerisation photochimique; Acrylate polymere; Materiau hybride; Titane oxyde-SEC; Micelle inverse; Materiau transparent; Cinetique; Procede sol gel; Nanocomposite; Titanate-ENT; Polymere reticule; Relation mise en oeuvre structure; Morphologie; Degre dispersion; Mecanisme reaction; Etude experimentale; Materiau composite; Polimerizacion fotoquimica; Acrilato polimero; Material hibrido; Titanio oxido-SEC; Micela inversa; Material transparente; Cinetica; Procedimiento sol gel; Nanocompuesto; Titanato-ENT; Polimero reticulado; Relacion puesta en marcha estructura; Morfologia; Grado dispersion; Mecanismo reaccion; Estudio experimental; Material compuesto  
PASC

7/8/1039 (Item 31 from file: 36)

MetalBase

(c) 2010 The Thomson Corporation. All rights reserved.

0004710899

**Electronic states and photoexcitation processes of titanium dioxide nanoparticle films dip coated from aqueous Degussa P25 photocatalyst suspension - art. no. 023714  
2007**

**Identifiers:** SURFACE PHOTOVOLTAGE SPECTROSCOPY; NANOCRYSTALLINE TIO<sub>2</sub> FILMS; RESOLVED INFRARED-ABSORPTION; SENSITIZED SOLAR-CELLS; THIN-FILMS; PHOTOGENERATED ELECTRONS; TRANSFER DYNAMICS; NANOPOROUS TIO<sub>2</sub>; TRANSPORT; EFFICIENCY  
CURC

7/8/1040 (Item 32 from file: 36)

MetalBase

(c) 2010 The Thomson Corporation. All rights reserved.

0004691129 **IP Accession No.:** 06-0454968

**Stabilized dispersions of titania nanoparticles via a sol-gel process and applications in UV-curable hybrid systems  
2006**

**Descriptors:** Titanium oxide-SEC; Sol gel **process**; Hybrid material; Coating material; Coupling agent; Particle size; Hardness; Nanocomposite; Photopolymerization; Methacrylate polymer; Phosphorus polymer; Lateral group; Organic phosphate; Structure **processing** relationship; Titanates-SEC-ACT; Morphology; Polymer filler interaction; Experimental study; Mechanical properties; Composite material; Titane oxyde-SEC; Procede sol gel; Materiau hybride; Materiau revetement; Agent accrochage; Dimension particule; Durete; Nanocomposite; Polymerisation photochimique; Methacrylate polymere; Polymere phosphore; Groupe lateral; Phosphate organique; Relation mise en oeuvre structure; Titanate-SEC-ACT; Morphologie ; Interaction matiere charge polymere; Etude experimentale; Propriete mecanique; Materiau composite; Titanio oxido-SEC; Procedimiento sol gel; Material hibrido; Material revestimiento; Agente enganche; Dimension particula; Dureza;

## Appendix A-5. Irrelevant Titles

Nanocompuesto; Polimerizacion fotoquimica; Metacrilato polimero; Polimero fosforo;  
Grupo lateral; Fosfato organico; Relacion puesta en marcha estructura; Titanato-SEC-ACT;  
Morfologia; Interaccion materia carga polimero; Estudio experimental; Propiedad mecanica;  
Material compuesto  
PASC

7/8/1041 (Item 33 from file: 36)

MetalBase

(c) 2010 The Thomson Corporation. All rights reserved.

0004678290 IP Accession No.: 06-0406392

### **Finishing of cotton fabrics with aqueous nano-titanium dioxide dispersion and the decomposition of gaseous ammonia by ultraviolet irradiation 2006**

**Descriptors:** Textile finishing; Cotton; Woven material; Natural fiber; Synthetic fiber; Polymer blends; Ester polymer; Chemical treatment; Aqueous dispersion; Nanoparticle; Titanium IV Oxides; Photocatalysis; Photochemical degradation ; Ammonia; Property **processing** relationship; Whiteness; Mechanical properties; Use; Decontamination; Indoor pollution; Experimental **study**; Finissage textile; Coton; Tissu textile; Fibre naturelle; Fibre synthetique; Melange polymere; Ester polymere; Traitement chimique; Dispersion aqueuse; Nanoparticule; Titane IV Oxyde; Photocatalyse; Degradation photochimique; Ammoniac; Relation mise en oeuvre propriete; Blancheur; Propriete mecanique; Utilisation; Decontamination; Pollution interieur; Etude experimentale; Degradation photooxydante; Acabado textil; Algodon; Tela textil; Fibra natural; Fibra sintetica; Ester polimero; Tratamiento quimico; Dispersion acuosa; Nanoparticula; Titanio IV Oxido; Fotocatalisis; Degradacion fotoquimica; Amoniaco; Relacion puesta en marcha propiedad; Blancura; Propiedad mecanica; Uso; Descontaminacion; Polucion interior; Estudio experimental  
PASC

7/8/1042 (Item 34 from file: 36)

MetalBase

(c) 2010 The Thomson Corporation. All rights reserved.

0004670629 IP Accession No.: 06-0372283

### **Fabrication of PEO SUB 1 SUB 7 -OPV SUB 3 templated titania nano-hollow rods and their aggregating microspheres 2006**

**Descriptors:** Phenylenevinylene copolymer; Diblock copolymer; Ethylene oxide copolymer; Amphiphilic polymer; Asymmetric molecule; Luminescent material; Titanium-SEC; Nanostructured materials; Hollow shape; Chemical synthesis; Sol gel **process**; Template reaction; Morphology; Formation mechanism; Spherical particle; Composite particles; Microparticle; Experimental study; Phenylenevinylene copolymere; Copolymere bisequence; Ethylene oxyde copolymere; Polymere amphiphile; Molecule asymetrique; Materiau luminescent ; Titane-SEC; Nanomateriau; Forme creuse; Synthese chimique; Procede sol gel; Reaction dirigee; Morphologie; Mecanisme formation; Particule spherique; Particule composite; Microparticule; Etude experimentale; Titane IV isopropanolate-ENT; Nanotige

## Appendix A-5. Irrelevant Titles

creuse; Faisceau nanotige; Fenilenovinileno copolimero; Copolimero biseuencia; Etileno oxido copolimero; Polimero amfifilo; Molecula asimetrica; Material luminescente; Titanio-SEC; Forma hueca; Sintesis quimica; Procedimiento sol gel; Reaccion dirigida; Morfologia; Mecanismo formacion; Particula esferica; Microparticula; Estudio experimental  
PASC

7/8/1043 (Item 35 from file: 36)

MetalBase

(c) 2010 The Thomson Corporation. All rights reserved.

0004618461 **IP Accession No.:** 221931

**Nanostructured and conventional titania coatings for abrasion and slurry-erosion resistance sprayed via APS [air plasma spraying], VPS [vacuum plasma spraying] and HVOF [high velocity oxyfuel].**

**2005**

**Descriptors:** SYMPOSIA; PLASMA SPRAYING; COATING METHODS; SPRAYING; SPRAYED COATINGS; COATINGS; HVOF SPRAYING; FLAME SPRAYING; WEAR RESISTANCE; MECHANICAL PROPERTIES; STRENGTH; EROSION; WEAR; ANGLE; TITANIA; CERAMICS; OXIDES; MICROSTRUCTURE; POROSITY; CAVITIES; DEFECTS; COMPARISONS; **PROCESS** SELECTION; SELECTION; HARDNESS; CRACK PROPAGATION; ADHESION; ROUGHNESS; SURFACE CONDITIONS; PLASTIC DEFORMATION; DEFORMATION; MICROCRACKS; CRACK PATTERN; CRACKING; BRITTLE FRACTURE; FRACTURES; CERAMIC COATINGS; NONMETALLIC COATINGS; OXIDE COATINGS; VACUUM; GASES; PARTICLE SIZE; PARTICLES; REFERENCE LISTS  
WELD

7/8/1044 (Item 36 from file: 36)

MetalBase

(c) 2010 The Thomson Corporation. All rights reserved.

0004590665

**Comparative study of sol-gel-hydrothermal and sol-gel synthesis of titania-silica composite nanoparticles**

**2005**

**Descriptors:** calcination; catalysis; decomposition; Fourier transform spectra; infrared spectra; magic angle spinning; nanoparticles; nanotechnology; particle reinforced composites; phase transformations; photochemistry; silicon compounds; sol-gel **processing**; titanium compounds; transmission electron microscopy; X-ray diffraction; X-ray photoelectron spectra

**Identifiers:** sol-gel-hydrothermal synthesis; titania-silica composite nanoparticles; photocatalytic properties; XRD; TEM; anatase; rutile; phase transformation; agglomeration; FTIR; XPS; /sup 29/Si MAS-NMR; methylene decomposition; calcination; 1000 degC; TiO/sub 2/-SiO/sub 2/  
INSP

## Appendix A-5. Irrelevant Titles

7/8/1045 (Item 37 from file: 36)

MetalBase

(c) 2010 The Thomson Corporation. All rights reserved.

0004590204

**Diffusion-equation approach to describe ionic mobility in nanostructured titania - art. no. 155401**

**2005**

**Identifiers:** O THIN-FILMS; MICROSTRUCTURAL CHARACTERIZATION; RUTHERFORD BACKSCATTERING; THERMODYNAMIC PROPERTIES; LOW-TEMPERATURE; NANOPARTICLES; COALESCENCE; TRANSPORT  
CURC

7/8/1046 (Item 38 from file: 36)

MetalBase

(c) 2010 The Thomson Corporation. All rights reserved.

0004568193 **IP Accession No.:** 05-0358358

**Fabrication of au/titania composite nanodot arrays from au-loaded block copolymer micellar films**

**2005**

**Descriptors:** Styrene copolymer; Diblock copolymer; Pyridine(2-vinyl) copolymer; Monodispersed polymer; Monolayer; Micellar systems; Reaction support; Template activity; Chemical reduction; Gold compound-ENT; Chemical vapor deposition; Titanium chloride-ENT; Composite particles; Nanoparticle; Array ; Gold-FIN; Titanium oxide-FIN; Semiconductor materials; Plasma assisted **processing; Manufacturing;** Experimental study; Styrene copolymere; Copolymere bisequence; Pyridine(2-vinyl)copolymere; Polymere monodisperse; Couche monomoleculaire; Systeme micellaire; Support reaction; Activite matricielle; Reduction chimique; Or compose-ENT; Depot chimique phase vapeur; Titane chlorure-ENT; Particule composite; Nanoparticule; Reseau(arrangement); Or-FIN; Titane oxyde-FIN; Semiconducteur; Traitement par plasma; Fabrication; Etude experimentale; Acide tetrachloroaurique-ENT; Film micellaire; Estireno copolimero; Copolimero bisequencia; Piridina(2-vinil) copolimero; Polimero monodispersado; Capa monomolecular; Soporte reaccion; Actividad modelo; Reduccion quimica; Oro compuesto-ENT; Deposito quimico fase vapor; Titanio cloruro-ENT; Nanoparticula; Red; Oro-FIN; Titanio oxido-FIN; Semiconductor(material); Fabricacion; Estudio experimental  
PASC

7/8/1047 (Item 39 from file: 36)

MetalBase

(c) 2010 The Thomson Corporation. All rights reserved.

0004454731 **IP Accession No.:** 218570

**Abrasion behaviour of nanostructured and conventional titania coatings thermally sprayed via APS [air plasma spraying], VPS [vacuum plasma spraying] and HVOF [high velocity oxyfuel].**

**2004**

## Appendix A-5. Irrelevant Titles

**Descriptors:** CAVITIES; CERAMIC COATINGS; CERAMICS; COATING METHODS; COATINGS; CRACK PROPAGATION; DEFECTS; FLAME SPRAYING; HARDNESS; HVOF SPRAYING; MECHANICAL PROPERTIES; MICROSTRUCTURE; NONMETALLIC COATINGS; OXIDE COATINGS; OXIDES; PARTICLE SIZE; PARTICLES; PLASMA SPRAYING; POROSITY; POWDER; **PROCESS** CONDITIONS; **PROCESS** PARAMETERS; **PROCESS** SELECTION; REFERENCE LISTS; SELECTION; SPEED; SPRAYED COATINGS; SPRAYING; STRENGTH; SYMPOSIA; TEMPERATURE; TITANIA; WEAR; WEAR RESISTANCE  
WELD

7/8/1048 (Item 40 from file: 36)

MetalBase

(c) 2010 The Thomson Corporation. All rights reserved.

0004433594 **IP Accession No.:** 05-0049722

**Preparation and thermal stability of gold nanoparticles in silk-templated porous filaments of titania and zirconia**

**2004**

**Descriptors:** Inorganic compounds; Organic compounds; Polymers; Compose mineral; Compose organique; Polymere  
PASC

7/8/1049 (Item 41 from file: 36)

MetalBase

(c) 2010 The Thomson Corporation. All rights reserved.

0004328452 **IP Accession No.:** 03-0305157

**Fabrication of titania nanofibers by electrospinning**

**2003**

**Descriptors:** Experimental study; Nanostructures; Nanostructured materials; Fibers; Porous materials; Preparation; Spinning; Electric fields; Anatase; Titanium oxides; Oxide ceramics; Nanocomposite; Polymers; PVP; Amorphous state; Calcination; **Process** control; Etude experimentale; Nanostructure; Nanomateriau; Fibre; Materiau poreux; Preparation; Filage; Champ électrique ; Anatase; Titane oxyde; Ceramique oxyde; Nanocomposite; Polymere; Pyrrolidone(vinyl) polymere; Etat amorphe; Calcination; Commande **processus**; 8107B; TiO<sub>2</sub>; O Ti; Preparacion; Hilado; Anatasa; Ceramica oxido; Nanocompuesto; Inorganic compounds Oxides Transition element compounds; Compose mineral Oxyde Metal transition compose  
PASC

7/8/1050 (Item 42 from file: 36)

MetalBase

(c) 2010 The Thomson Corporation. All rights reserved.

0004321567 **IP Accession No.:** 03-0178525

**Novel approach to the fabrication of macroporous polymers and their use as a template**

## Appendix A-5. Irrelevant Titles

### for crystalline titania nanorings

2003

**Descriptors:** Experimental study; Colloidal dispersion; Polymer networks; Styrene copolymer; Benzene(divinyl) copolymer; Preparation; Template; Porous materials; Self-assembly; Two dimensional structure; Three dimensional structure; Honeycomb structures; Pore size; **Process** control; Spin-on coating; Calcination; Nanostructured materials; Nanocrystal; Titanium oxides; Rings; Etude experimentale; Dispersion colloïdale; Polymere reticule; Styrene copolymere; Benzene(divinyl) copolymere; Preparation; Template; Materiau poreux; Autoassemblage; Structure 2 dimensions; Structure 3 dimensions; Structure nid abeille; Dimension pore; Commande **processus**; Depot centrifugation; Calcination; Nanomateriau; Nanocrystal; O Ti; 8107B; Titane oxyde; Anneau; Structure opale inverse; TiO<sub>2</sub>; Dispersion coloidal; Estireno copolimero; Benceno(divinil) copolimero ; Preparacion; Estructura 2 dimensiones; Estructura 3 dimensiones; Dimension poro; Nanocrystal; Inorganic compounds Transition element compounds; Compose mineral Metal transition compose PASC

7/8/1051 (Item 43 from file: 36)

MetalBase

(c) 2010 The Thomson Corporation. All rights reserved.

0004143220 **IP Accession No.:** 02-0361540

**Titanium dioxide nanoparticle films made by using poly(ethylene glycol) oligomers as templates, Trends in colloid and interface science XV : Patras, September 2000**

2001

**Descriptors:** Nanoparticle; Titanium Oxides; Ethylene oxide polymer; Oligomer; Structure effect; Chain length; Atomic force microscopy; Nanoparticule; Titane Oxyde; Ethylene oxyde polymere; Oligomere; Effet structure; Longueur chaine; Microscopie force atomique; Nanoparticula; Titanio Oxido; Etileno oxido polimero; Oligomero; Efecto estructura; Longitud cadena; Microscopia fuerza atomica; Transition metal Compounds; Metal transition Compose; Metal transicion Compuesto PASC

7/8/1052 (Item 44 from file: 36)

MetalBase

(c) 2010 The Thomson Corporation. All rights reserved.

0004134664 **IP Accession No.:** 01-0460983

**Photoluminescence characteristics of neodymium oxide nanocrystal/ titania/ormosil composite sol-gel thin films**

2001

**Descriptors:** Photoluminescence; Energy-level transitions; Heat treatments; TEM; Synthesis; Sol-gel **process**; Thin films; Composite materials; Nanocrystal; Neodymium oxides; Titanium oxides; Organic silane; Experimental study; Nanoparticles; Photoluminescence; Transition niveau energie; Traitement thermique; TEM; Synthese; Procede sol gel; Couche mince ; Materiau composite; Nanocrystal; Neodyme oxyde; Titane oxyde; Silane organique; Etude experimentale; Nd O; 7855K; Nanoparticule; Nanocrystal; Silano organico

## Appendix A-5. Irrelevant Titles

PASC

7/8/1053 (Item 45 from file: 36)

MetalBase

(c) 2010 The Thomson Corporation. All rights reserved.

0004117171 **IP Accession No.:** 01-0091448

**Up-conversion luminescence of erbium (III) oxalate nanoparticles/ titania/y-glycidoxypropyltrimethoxysilane composite sol-gel thin films**  
**2001**

**Descriptors:** Experimental study; Luminescence; Nanostructured materials; Thin films; Sol-gel **process**; Composite materials; Erbium compounds; Oxalates; Organic silane; TEM; Ultraviolet spectra; Visible spectra; Titanium oxides; Photonic crystal; Etude experimentale; Luminescence; Nanomateriau; Couche mince; Procede sol gel; Materiau composite; Erbium compose; Oxalate; Silane organique; TEM; Spectre UV; Spectre visible; Titane oxyde; Cristal photonique; 7866S; 7855; 4270Q; Silano organico; Cristal fotonico  
PASC

7/8/1054 (Item 1 from file: 40)

Enviroline(R)

(c) 2008 Congressional Information Service. All rights reserved.

00718027 **Enviroline Number:** 07-12562

**Behavioral and Physiological Changes in Daphnia magna when Exposed to Nanoparticle Suspensions (Titanium Dioxide, Nano-C60, and C60HxC60)**

Jun 15, 07

**Special Features:** 8 graph(s) 43 reference(s) 1 table(s)

**Major Descriptors:** TITANIUM DIOXIDE; RISK ASSESSMENT; PHYSIOLOGICAL RESPONSES; TOXICOLOGY; REPRODUCTION; ENV MANAGEMENT; AQUATIC ECOSYSTEMS; RAINWATER ;

**Review Classification:** 02

7/8/1055 (Item 2 from file: 40)

Enviroline(R)

(c) 2008 Congressional Information Service. All rights reserved.

00699313 **Enviroline Number:** 06-12385

**Application of Nanometer-Size Titanium Dioxide in Extreme-Trace V(V) Analysis**

Mar 06

**Special Features:** 1 graph(s) 11 reference(s) 3 table(s)

**Major Descriptors:** TITANIUM DIOXIDE; WATER POLLUTION; GRAPHITE; VANADIUM; ATOMIC ABSORPTION; ACIDS; WATER ANALYSIS; CHEMICALS ;

**Review Classification:** 19

7/8/1056 (Item 1 from file: 41)

## Appendix A-5. Irrelevant Titles

Pollution Abstracts

(c) 2009 CSA. All rights reserved.

0000360467 IP Accession No: 8751927

**Suppression of dioxin emission in incineration of poly(vinyl chloride) (PVC) as hybridized with titanium dioxide (TiO<sub>2</sub>) nanoparticles**

**Publication Date: 2008**

**Descriptors:** Catalysis; Chlorides; Dioxins; Emissions; Exhaust emissions; Furnaces; Incineration; Polymers; Solvents; Spectroscopy; composite materials; titanium dioxide

**Subj Catg:** 0000, AIR POLLUTION

7/8/1057 (Item 2 from file: 41)

Pollution Abstracts

(c) 2009 CSA. All rights reserved.

0000344230 IP Accession No: 8321602

**Acute Toxicity of Nanometer Titanium Dioxide to Liver and Kidney of Mice**

**Publication Date: 2008**

**Descriptors:** Acute **toxicity**; Alanine; Bilirubin; Body weight; Cytoplasm; Degeneration; Glomerulus; Hepatocytes; Histopathology; Kidney; Liver; Mice; Necrosis; Nitrogen; Osteoporosis; Paraffin; Titanium dioxide; **Toxicity**; Urea; Veins; acute **toxicity**; body weight; dehydrogenase; osteoporosis; renal tubules; titanium dioxide; urea

**Subj Catg:** 6000, TOXICOLOGY AND HEALTH

7/8/1059 (Item 4 from file: 41)

Pollution Abstracts

(c) 2009 CSA. All rights reserved.

0000326822 IP Accession No: 7110234

**Bioaccumulation of Titanium Dioxide Nanoparticles in Carp**

**Publication Date: 2006**

**Descriptors:** Ammonium; Bioaccumulation; Gills; Muscles; Sulfuric acid; Water **sampling**; titanium dioxide; Cyprinus carpio

**Subj Catg:** 2000, FRESHWATER POLLUTION

7/8/1060 (Item 1 from file: 57)

Electronics & Communications Abstracts

(c) 2009 CSA. All rights reserved.

0000722245 IP Accession No: 200903-34-0011052

**ESR Analysis on the Ozone Enhanced Photocatalytic Activity of Aqueous Nanosized Titanium Dioxide Suspensions**

**Publication Date: 2008**

**Descriptors:** Titanium dioxide; Nanostructure; Ozone; Nanocomposites; Electron spin resonance; Nanomaterials; Electron paramagnetic resonance; Reaction time; Dissolution; Catalysts; Photocatalysis

**Subj Catg:** 34, Vision

## Appendix A-5. Irrelevant Titles

7/8/1061 (Item 2 from file: 57)

Electronics & Communications Abstracts

(c) 2009 CSA. All rights reserved.

0000687816 IP Accession No: 200807-34-0031300

**Preparation and Photoelectric Performance of Flexible Titania Nanotubes Thin Filth**

**Publication Date: 2008**

**Descriptors:** Titanium dioxide; Nanotubes; Electrodes; Photoelectricity; Dyes; Energy conversion efficiency; Surface chemistry; Isotherms; Thin films; Transmission electron microscopy; Short circuit currents; Astronautics; Morphology

**Subj Catg:** 34, Vision

7/8/1062 (Item 3 from file: 57)

Electronics & Communications Abstracts

(c) 2009 CSA. All rights reserved.

0000578388 IP Accession No: 200703-34-015108

**Effects of Gelatin on Phase Transformation and Photocatalytic Activity of Nano-size Titanium Dioxide**

**Publication Date: 2006**

**Descriptors:** Gelatins; Titanium dioxide; Photocatalysis; Nanostructure; Nanocrystals; Dosage; Phase transformations; Roasting; Anatase; Particle size; Transformation temperature; Fine chemicals; Titanates; Sol gel **process**; Nanomaterials; Tetrabutyls; Dispersants; Oranges; Calcination; Photodegradation; Atomic force microscopy; Mass ratios; Nanocomposites

**Subj Catg:** 34, Vision

7/8/1067 (Item 8 from file: 57)

Electronics & Communications Abstracts

(c) 2009 CSA. All rights reserved.

0000323379 IP Accession No: 200604-20-07749

**Characterisation of nano-crystalline titanium dioxide films grown by atmospheric pressure plasma electrolytic deposition**

**Publication Date: 2006**

**Descriptors:** Titanium dioxide; Coating; Deposition; Atmospheric pressure; X-rays; Nanocrystals; Barometric pressure; Thin films; Ethyl alcohol; Scanning electron microscopy; Cathodes; Electric potential; Voltage; Anatase; Crystal structure; Rutile; Current voltage characteristics; Nanocrystalline ; Physical properties; Liquid phases

**Subj Catg:** 20, Components and Materials (General)

7/8/1068 (Item 9 from file: 57)

Electronics & Communications Abstracts

(c) 2009 CSA. All rights reserved.

## Appendix A-5. Irrelevant Titles

0000270417 IP Accession No: 200312-74-0234

**Hydrothermal synthesis of titania nano colloids to dye-sensitized solar cell**

**Publication Date: 2003**

**Descriptors:** Titania; Synthesis; Colloids; Production; pH; Components; Capacity; Photographs; Oxidation; Autoclaves; Stabilizers; Glycols; Temperature; Reaction time; Semiconductors (materials); Products; Tables (data); Ratios; Crystallites; Functions; Solar cells; Electrodes

**Subj Catg:** 74, Solar Cells

7/8/1069 (Item 10 from file: 57)

Electronics & Communications Abstracts

(c) 2009 CSA. All rights reserved.

0000250117 IP Accession No: 611895

**Effects of erbium oxalate content and temperature on green up-conversion luminescence of erbium oxalate nanoparticles/titania/ormosil composite thin films**

**Publication Date: 2002**

**Descriptors:** Erbium compounds; Thin films; Nanostructured materials; Microemulsions; Sol-gels; Heat treatment; Low temperature effects

**Identifiers:** Photon absorptions

**Subj Catg:** E 741.1, Light/Optics; E 804.2, Inorganic Compounds; E 714.2, Semiconductor Devices and Integrated Circuits; E 933.1, Crystalline Solids; E 537.1, Heat Treatment Processes; E 644.4, Cryogenics

7/8/1070 (Item 1 from file: 60)

ANTE: Abstracts in New Tech & Engineer

(c) 2009 CSA. All rights reserved.

0000359811 IP Accession No: 283403

**Nano technology meets titanium dioxide.**

**Publication Date: 2004**

**Descriptors:** Paint; Pigments; Titanium dioxide; Nanoparticles; Paint; Pigments; Titanium dioxide; Nanoparticles

7/8/1071 (Item 1 from file: 64)

Environmental Engineering Abstracts

(c) 2009 CSA. All rights reserved.

0000300495 IP Accession No: 10140321

**Photocatalytic decomposition of direct red 16 and kinetics analysis in a conic body packed bed reactor with nanostructure titania coated Raschig rings**

**Publication Date: 2009**

**Descriptors:** Kinetics; Model Studies; Decomposition; Streams; Degradation; Industrial Wastewater; Azo Dyes; Chemical Engineering; Hydroxyl Radical; Hydroxyl radicals; Photolysis; Wastewater; Particulates; pH; Temperature; Titanium dioxide; Mathematical models; Photocatalysis; Dyes; Nanostructure; Decomposition reactions; Degradation; Power law; Reactors

## Appendix A-5. Irrelevant Titles

**Subj Catg:** , EE 50 Water & Wastewater Treatment

7/8/1073 (Item 2 from file: 65)

Inside Conferences

(c) 2010 BLDSC all rts. reserv. All rights reserved.

0007136088 **Inside Conference Item ID:** CN073528845

**Application of highly ordered arrays of Titania-coated titanium nanorods in enhanced photoelectro chemical cells**

**Conference:** International Solar Energy Society; solar energy and human settlement; edited by D. Yogi Goswami, Yuwen Zhao - Conference ( 200700 )

**Descriptors:** Solar energy; Solar energy; Human settlements

7/8/1074 (Item 3 from file: 65)

Inside Conferences

(c) 2010 BLDSC all rts. reserv. All rights reserved.

0007128830 **Inside Conference Item ID:** CN073456264

**Quantitative Proteomic Analysis of Mouse Lymph Nodes Exposed to Titanium Dioxide Nanoparticles**

**Conference:** Mass spectrometry and allied topics; ASMS - Conference; 57th ( 200905 )

**Descriptors:** Mass spectrometry; Spectrometry; ASMS

7/8/1075 (Item 4 from file: 65)

Inside Conferences

(c) 2010 BLDSC all rts. reserv. All rights reserved.

0007107392 **Inside Conference Item ID:** CN073241880

**Ruthenium Tris-bypyridine/Zeolite-Y/Titanium Dioxide Nano-Assembly: `Ship-in-a-Bottle' Synthesis and Application in Heterogeneous Photodegradation of 2,4-xylidine**

**Conference:** Eurasia Conference on Chemical Sciences; Innovations in chemical biology - 9th ( 200600 )

**Descriptors:** Biochemistry

7/8/1076 (Item 5 from file: 65)

Inside Conferences

(c) 2010 BLDSC all rts. reserv. All rights reserved.

0007105250 **Inside Conference Item ID:** CN073220463

**Influence of Glacial Acetic Acid and Nitric Acid as a Chelating Agent in Sol-Gel Process to the Nanostructured Titanium Dioxide Thin Films**

**Conference:** International Conference on Nanoscience and Nanotechnology ( 200800 )

**Descriptors:** Nanoscience; Nanotechnology

7/8/1077 (Item 6 from file: 65)

## Appendix A-5. Irrelevant Titles

Inside Conferences

(c) 2010 BLDSC all rts. reserv. All rights reserved.

0007049521 **Inside Conference Item ID:** CN072661550

**Formation of Anodic Titania Nanotubes and Application**

**Conference:** Electrochemical Society - Meeting; 214th ( 200810 )

**Descriptors:** electrochemical; ECS

7/8/1078 (Item 7 from file: 65)

Inside Conferences

(c) 2010 BLDSC all rts. reserv. All rights reserved.

0007020507 **Inside Conference Item ID:** CN072371419

**Synthesis of Nanometer Core-shelled Titanium Dioxide /Tungsten Oxide Powder**

**Conference:** Minerals, Metals and Materials Society. Extraction and Processing Division;

EPD Congress 2009 - Congress ( 200902 )

**Descriptors:** Extraction; Minerals processing

7/8/1079 (Item 8 from file: 65)

Inside Conferences

(c) 2010 BLDSC all rts. reserv. All rights reserved.

0006943640 **Inside Conference Item ID:** CN071590020

**Modification of Nanometer Titanium Dioxide and Its Application as Part of Novel Retention Systems**

**Conference:** International Papermaking and Environment Conference - 2nd ( 200805 )

**Descriptors:** Papermaking industry; Environmental concerns

7/8/1080 (Item 9 from file: 65)

Inside Conferences

(c) 2010 BLDSC all rts. reserv. All rights reserved.

0006916199 **Inside Conference Item ID:** CN071315616

**Development of Novel Biocompatible Hydroxyapatite Coated Nanotubular Titania for Implant Application**

**Conference:** Porous ceramics: Novel developments and applications; Advances in bioceramics and porous ceramics - Symposium ( 200801 )

**Descriptors:** Porous ceramics; Next generation bioceramics; Advanced ceramics; Composites; ICACC

7/8/1081 (Item 10 from file: 65)

Inside Conferences

(c) 2010 BLDSC all rts. reserv. All rights reserved.

0006901603 **Inside Conference Item ID:** CN071169650

**Synthesis and Characterization of Anatase Titania Nanoparticles for Acetic Acid Wastewater Treatment**

## Appendix A-5. Irrelevant Titles

**Conference:** American Chemical Society. Division of Environmental Chemistry - Meeting; 236th ( 200808 )

**Descriptors:** Environmental chemistry

7/8/1082 (Item 11 from file: 65)

Inside Conferences

(c) 2010 BLDSC all rts. reserv. All rights reserved.

0006812264 **Inside Conference Item ID:** CN070262421

**Light Scattering in Poly(Methyl Methacrylate) Hybrid Sheet Filled by Titanium Dioxide Nanocrystals Prepared by High Electric Field Assisted Spray Pyrolysis Process**

**Conference:** International Conference on Smart Materials, Smart/Intelligent Materials and Nanotechnology ( Advanced materials research ) ( 200800 )

**Descriptors:** Smart materials; Nanotechnology

7/8/1083 (Item 12 from file: 65)

Inside Conferences

(c) 2010 BLDSC all rts. reserv. All rights reserved.

0006742515 **Inside Conference Item ID:** CN069544512

**Process dynamics of titanium dioxide nanoparticle formation: simultaneous agglomeration and redispersion kinetics**

**Conference:** International congress of chemical and process engineering - 17th ( 200608 )

**Descriptors:** Chemical engineering; Process engineering; CHISA

7/8/1084 (Item 13 from file: 65)

Inside Conferences

(c) 2010 BLDSC all rts. reserv. All rights reserved.

0006742163 **Inside Conference Item ID:** CN069540994

**Influence of nanometric titanium dioxide on the thermal and light stability of PVC**

**Conference:** International congress of chemical and process engineering - 17th ( 200608 )

**Descriptors:** Chemical engineering; Process engineering; CHISA

7/8/1085 (Item 14 from file: 65)

Inside Conferences

(c) 2010 BLDSC all rts. reserv. All rights reserved.

0006741963 **Inside Conference Item ID:** CN069538990

**Effect of the calcine condition on surface structure of titania nanocrystal photocatalyst**

**Conference:** International congress of chemical and process engineering - 17th ( 200608 )

**Descriptors:** Chemical engineering; Process engineering; CHISA

7/8/1086 (Item 15 from file: 65)

## Appendix A-5. Irrelevant Titles

Inside Conferences

(c) 2010 BLDSC all rts. reserv. All rights reserved.

0006741218 **Inside Conference Item ID:** CN069531543

**Synthesis of Titania Nanostructures and their Application as Catalyst Supports for Hydrogenation and Oxidation Reactions**

**Conference:** Perspectives of nanoscience and nanotechnology - workshop ( 200709 )

**Descriptors:** Nanotechnology; Nanoscience

7/8/1087 (Item 16 from file: 65)

Inside Conferences

(c) 2010 BLDSC all rts. reserv. All rights reserved.

0006659895 **Inside Conference Item ID:** CN068775113

**Synthesis of Nano Titanium Dioxide and Its Application in Photocatalysis**

**Conference:** International workshop on functional materials IWO FM - 1st ( 200612 )

**Descriptors:** Functional materials; Nanophysics; Materials science

7/8/1088 (Item 17 from file: 65)

Inside Conferences

(c) 2010 BLDSC all rts. reserv. All rights reserved.

0006649263 **Inside Conference Item ID:** CN068668795

**Preparation of Nanoporous Titania Photocatalyst with High Photocatalytic Activity Using Metatitanic Acid**

**Conference:** Materials processing for properties and performance - International conference; 6th ( 200709 )

**Descriptors:** Materials **processing**; Properties; Performance; MP3

7/8/1089 (Item 18 from file: 65)

Inside Conferences

(c) 2010 BLDSC all rts. reserv. All rights reserved.

0006511508 **Inside Conference Item ID:** CN067278561

**Synthesis and Characterisation of Titania Nanotubes: Effect of Phase and Crystallite Size on Nanotube Formation**

**Conference:** Advanced materials and processing - INTERNATIONAL CONFERENCE; 4th ( 200612 )

**Descriptors:** **Manufacturing processes**; Materials; Advanced materials; ICAMP; **Processing**

7/8/1090 (Item 19 from file: 65)

Inside Conferences

(c) 2010 BLDSC all rts. reserv. All rights reserved.

0006468241 **Inside Conference Item ID:** CN066831447

## Appendix A-5. Irrelevant Titles

### **Photocatalytic hydrogen production over CdS/titania- nanotube composite films [6650-31]**

**Conference:** Solar hydrogen and nanotechnology - Conference; 2nd ( 200708 )

**Descriptors:** Solar energy; Nanotechnology; Photocatalysis; Solar hydrogen; SPIE

7/8/1091 (Item 20 from file: 65)

Inside Conferences

(c) 2010 BLDSC all rts. reserv. All rights reserved.

0006468235 **Inside Conference Item ID:** CN066831381

### **Photocatalytic hydrogen production using surface-modified titania nanoparticles [6650-18]**

**Conference:** Solar hydrogen and nanotechnology - Conference; 2nd ( 200708 )

**Descriptors:** Solar energy; Nanotechnology; Photocatalysis; Solar hydrogen; SPIE

7/8/1092 (Item 21 from file: 65)

Inside Conferences

(c) 2010 BLDSC all rts. reserv. All rights reserved.

0006438842 **Inside Conference Item ID:** CN066522177

### **Synthesis of Anodized Titania Nanotubes Array and Its Application to Gas Sensors**

**Conference:** Sensor symposium on sensors, micromachines and applied systems - 24th ( 200710 )

**Descriptors:** Sensors; Micromachines; Applied systems

7/8/1094 (Item 23 from file: 65)

Inside Conferences

(c) 2010 BLDSC all rts. reserv. All rights reserved.

0006152981 **Inside Conference Item ID:** CN059149633

### **Nanosized titania produced by the sol-gel process**

**Conference:** Particle technology; PARTEC 2004 - INTERNATIONAL CONGRESS ( 200403 )

**Descriptors:** Particle technology; PARTEC

7/8/1095 (Item 24 from file: 65)

Inside Conferences

(c) 2010 BLDSC all rts. reserv. All rights reserved.

0006113382 **Inside Conference Item ID:** CN063191126

### **Effects of Substrate on Dye-Sensitized Solar Cell Performance Using Nanocrystalline Titania**

**Conference:** Symposium on Charge Transfer Processes in Semi-Conductor and Metal Nanoparticles; Electron transfer in nanomaterials ( 200405 )

**Descriptors:** Nanostructured materials; Nanoparticles; Charge transfer **processes** ; Metal

## Appendix A-5. Irrelevant Titles

nanoparticles

7/8/1096 (Item 25 from file: 65)

Inside Conferences

(c) 2010 BLDSC all rts. reserv. All rights reserved.

0006012537 **Inside Conference Item ID:** CN062204691

**Preparation of Normally-Aligned Titania Nanotube Layer Formed on Ti Substrate and Its Application to Dye-Sensitized Solar Cells**

**Conference:** Electrochemical Society; ECS - 208th.; MEETING ( 2005; , Oct )

**Descriptors:** Electrochemical; ECS

7/8/1097 (Item 26 from file: 65)

Inside Conferences

(c) 2010 BLDSC all rts. reserv. All rights reserved.

05977051 **Inside Conference Item ID:** CN061849838

**P3.136: Research and mathematical modeling of titania nanoparticles production via sol-gel technology**

**Conference:** International congress of chemical and process engineering; CHISA 2002 - 15th ( 200208 )

**Descriptors:** Chemical engineering; **Process** engineering; CHISA; CSCHI

7/8/1098 (Item 27 from file: 65)

Inside Conferences

(c) 2010 BLDSC all rts. reserv. All rights reserved.

05644821 **Inside Conference Item ID:** CN058527530

**Hydrogen Production Via Nanostructured Photocatalytic Titania Thin-Films**

**Conference:** American Institute of Chemical Engineers; 05 AIChE - Annual meeting and full showcase ( 200510 )

**Descriptors:** Chemical engineers; AIChE

7/8/1099 (Item 28 from file: 65)

Inside Conferences

(c) 2010 BLDSC all rts. reserv. All rights reserved.

05396403 **Inside Conference Item ID:** CN056029410

**Giant nonlinear optical response application for nanoporous titanium dioxide photocatalytic activity monitoring**

**Conference:** Porous semiconductors -science and technology; PSST 2004 - International conference; 4th ( 200403 )

**Descriptors:** PSST; Porous semiconductors

7/8/1100 (Item 29 from file: 65)

## Appendix A-5. Irrelevant Titles

Inside Conferences

(c) 2010 BLDSC all rts. reserv. All rights reserved.

05371114 **Inside Conference Item ID:** CN055776520

**Low Cost Integrated Sensors Utilizing Patterned Nano-Structured Titania Arrays Fabricated Using a Simple Process**

**Conference:** Semiconductor materials for sensing - Symposium ( 200411 )

**Descriptors:** Semiconductors; Metal oxide semiconductors; Detectors; Nanostructured materials; Integrated circuits; Sensing; Semiconductor materials

7/8/1101 (Item 30 from file: 65)

Inside Conferences

(c) 2010 BLDSC all rts. reserv. All rights reserved.

05335576 **Inside Conference Item ID:** CN055421144

**MORPHOLOGY EFFECT OF NANO-TITANIUM DIOXIDE PREPARED BY MICROEMULSION TECHNIQUE ON PHOTOCATALYTIC DECOMPOSITION OF PHENOL**

**Conference:** Process intensification & miniaturisation - 1st.; INTERNATIONAL SYMPOSIUM ( 200308 )

**Descriptors:** Process intensification; Miniaturisation; Energy conversion technologies; PIM

7/8/1102 (Item 31 from file: 65)

Inside Conferences

(c) 2010 BLDSC all rts. reserv. All rights reserved.

05289359 **Inside Conference Item ID:** CN054965540

**Effect of H SUB 2 on Microstructure and Property of Nano- Titania Coatings**

**Conference:** Eco-materials processing and design VI: proceedings of the 6th International symposium on eco-materials processing and design - International symposium; 6th ( 200501 )

**Descriptors:** Eco-materials processing

7/8/1103 (Item 32 from file: 65)

Inside Conferences

(c) 2010 BLDSC all rts. reserv. All rights reserved.

05219973 **Inside Conference Item ID:** CN054288138

**Titanium Dioxide Nano-Particles through Thermal Plasma Oxidation of Titanium Nitride Powders**

**Conference:** IUMRS/ICAM; Computational materials science and materials design & processing.: D-10 - Symposia ( 200310 )

**Descriptors:** Computational materials science; Materials design; IUMRS; ICAM; Processing

7/8/1104 (Item 33 from file: 65)

## Appendix A-5. Irrelevant Titles

Inside Conferences

(c) 2010 BLDSC all rts. reserv. All rights reserved.

05090278 **Inside Conference Item ID:** CN053004203

**Photochemical Properties of Titania Nanocrystals Prepared by Hydrothermal Process in Urea Solution**

**Conference:** Soft solution processing; SSP 2003 - International symposium; 3rd ( 200310 )

**Descriptors:** Soft solution **processing**; SSP; IUMRS; ICAM

7/8/1105 (Item 34 from file: 65)

Inside Conferences

(c) 2010 BLDSC all rts. reserv. All rights reserved.

05090265 **Inside Conference Item ID:** CN053004074

**Solvothermal Synthesis of Visible-light Reactive Titania Nanocrystals**

**Conference:** Soft solution processing; SSP 2003 - International symposium; 3rd ( 200310 )

**Descriptors:** Soft solution **processing**; SSP; IUMRS; ICAM

7/8/1106 (Item 35 from file: 65)

Inside Conferences

(c) 2010 BLDSC all rts. reserv. All rights reserved.

04922302 **Inside Conference Item ID:** CN051309982

**Synthesis and Novel Application of Nanomaterials in Tungstate, Titania and Silicon Nitride Systems**

**Conference:** Nanostructures: Synthesis, Functional Properties, Applications - NATO Advanced Study Institute ( 200106 )

**Descriptors:** nanostructures; functional properties; synthesis

7/8/1107 (Item 36 from file: 65)

Inside Conferences

(c) 2010 BLDSC all rts. reserv. All rights reserved.

04832209 **Inside Conference Item ID:**

CN050409053

**Nano Titanium Dioxide-Properties and Application**

**Conference:** Nanofair; new ideas for industry - Tagung ( 200311 )

**Descriptors:** nanofair; VDI; nanotechnik

7/8/1108 (Item 37 from file: 65)

Inside Conferences

(c) 2010 BLDSC all rts. reserv. All rights reserved.

04797579 **Inside Conference Item ID:** CN050062752

**TEM characterization of sol-gel-processed alumina-silica and alumina-titania nano-hybrid oxide catalysts**

**Conference:** Ceramic processing - International conference; 8th ( 200209 )

## Appendix A-5. Irrelevant Titles

**Descriptors:** ceramic **processing**

7/8/1109 (Item 38 from file: 65)

Inside Conferences

(c) 2010 BLDSC all rts. reserv. All rights reserved.

04302126 **Inside Conference Item ID:** CN045088870

**Laser Flash Photolysis Study of Intermolecular Electron Transfer Processes of Adsorbed Anthracene-N,Ndimethylaniline Pair on Titania-silica Nanosized Photocatalysts**

**Conference:** Electrochemical Society - Meeting; 201st ( 200205 )

**Descriptors:** electrochemical; ECS

7/8/1110 (Item 1 from file: 73)

EMBASE

(c) 2010 Elsevier B.V. All rights reserved.

0083388343 **EMBASE/MEDLINE No:** 2009609437

**Surface plasmon resonance biosensor based on Au nanoparticle in titania sol-gel membrane**

**Publication Date:** February 1, 2010

**Drug Descriptors:**

\* gold nanoparticle; \*immunoglobulin G; \*titanium dioxide colloidal gold; immunoglobulin G antibody

**Medical Descriptors:**

\* biosensor; \*surface plasmon resonance article; concentration response; controlled **study**; encapsulation; immobilization; molecular recognition; porosity; priority journal; protein **analysis**; sensitivity and specificity

**CAS Registry Number:** 117924-90-0 (colloidal gold); 97794-27-9 (immunoglobulin G); 1317-70-0, 1317-80-2, 13463-67-7, 51745-87-0 (titanium dioxide)

7/8/1111 (Item 2 from file: 73)

EMBASE

(c) 2010 Elsevier B.V. All rights reserved.

0083374008 **EMBASE/MEDLINE No:** 2009574620

**Carbon black and titanium dioxide nanoparticles induce pro-inflammatory responses in bronchial epithelial cells: Need for multiparametric evaluation due to adsorption artifacts**

**Publication Date:** December 28, 2009

**Drug Descriptors:**

\* carbon nanofiber; \*nanoparticle; \*titanium dioxide cell protein--endogenous compound--ec; granulocyte macrophage colony stimulating factor--endogenous compound--ec; interleukin 6--endogenous compound--ec; tumor necrosis factor alpha--endogenous compound--ec

**Medical Descriptors:**

\* bronchus mucosa; \*inflammation

## Appendix A-5. Irrelevant Titles

article; controlled **study**; cytokine release; **human**; **human cell**; priority journal; respiratory epithelium

**CAS Registry Number:** 1317-70-0, 1317-80-2, 13463-67-7, 51745-87-0 (titanium dioxide)

7/8/1114 (Item 5 from file: 73)

EMBASE

(c) 2010 Elsevier B.V. All rights reserved.

0083302468 **EMBASE/MEDLINE No:** 2009532661

**Fabrication and superhydrophobicity of fluorinated titanium dioxide nanocoatings**

**Publication Date:** December 15, 2009

**Drug Descriptors:**

\* fluoride; \*nanocoating; \*titanium dioxide

**water**

**Medical Descriptors:**

\* hydrophobicity

article; density; engineering; fluoridation; hysteresis; optics; priority journal; surface property; synthesis

**CAS Registry Number:** 16984-48-8 (fluoride); 1317-70-0, 1317-80-2, 13463-67-7, 51745-87-0 ( titanium dioxide); 7732-18-5 (water)

7/8/1115 (Item 6 from file: 73)

EMBASE

(c) 2010 Elsevier B.V. All rights reserved.

0083189050 **EMBASE/MEDLINE No:** 2009410546

**Preliminary in vitro investigation of the potential health effects of optisol, a nanoparticulate manganese modified titanium dioxide UV-filter used in certain sunscreen products**

**Publication Date:** June 1, 2009

**Drug Descriptors:**

\* nanoparticle--drug **toxicity**--to; \*titanium dioxide--drug **toxicity**--to manganese; sunscreen

**Medical Descriptors:**

article; controlled **study**; cytotoxicity; evaluation; eye irritation; genotoxicity; **health hazard**; **human**; **human cell**; phototoxicity; priority journal; screening; skin irritation; **toxicity** testing; ultraviolet radiation

**CAS Registry Number:** 16397-91-4, 7439-96-5 (manganese); 1317-70-0, 1317-80-2, 13463-67-7, 51745-87-0 (titanium dioxide)

7/8/1116 (Item 7 from file: 73)

EMBASE

(c) 2010 Elsevier B.V. All rights reserved.

0083130375 **EMBASE/MEDLINE No:** 2009357296

## Appendix A-5. Irrelevant Titles

### **Effects of NH SUB 3 .H SUB 2 O pretreatment on the fabrication of uniform titania nanocoating in an aqueous solution**

**Publication Date:** October 25, 2009

**Drug Descriptors:**

\* nitrite; \*titanium; \***water**  
diethanolamine; hydroxyl group; zinc sulfate

**Medical Descriptors:**

\* material coating; \*nanotechnology  
**aqueous** solution; article; binding kinetics; controlled study; hydrolysis; mathematical **analysis**; pH; scanning electron microscopy; suspension; X ray diffraction

**CAS Registry Number:** 111-42-2 (diethanolamine); 14797-65-0 (nitrite); 7440-32-6 (titanium); 7732-18-5 (water); 7733-02-0 (zinc sulfate)

7/8/1117 (Item 8 from file: 73)

EMBASE

(c) 2010 Elsevier B.V. All rights reserved.

0083049490 **EMBASE/MEDLINE No:** 2009301093

### **Comparative photoactivity and antibacterial properties of C SUB 60 fullerenes and titanium dioxide nanoparticles**

**Publication Date:** June 15, 2009

**Drug Descriptors:**

\* fullerene derivative--pharmaceutics--pr; \*fullerene derivative --pharmacology--pd;  
\*nanoparticle--pharmacology--pd  
fullerene--pharmacology--pd; hydroxyl radical--endogenous compound--ec; oxygen--endogenous compound--ec; povidone--pharmacology--pd; reactive oxygen metabolite--endogenous compound--ec; superoxide--endogenous compound --ec; tetrahydrofuran; unclassified drug; **water**

**Medical Descriptors:**

\* antibacterial activity; \*disinfection; \*photoactivation  
animal experiment; article; comparative study; culture medium; drug delivery system; Escherichia coli; hydroxylation; microbial **contamination**; microbial growth; microorganism; nanoencapsulation; nonhuman; oxidation; phototoxicity; pollutant; solar energy; suspension; ultraviolet radiation; **water** treatment

**Drug Terms (Uncontrolled):** titanium dioxide nanoparticle--pharmacology--pd

**CAS Registry Number:** 3352-57-6 (hydroxyl radical); 7782-44-7 (oxygen); 9003-39-8 (povidone); 11062-77-4 (superoxide); 109-99-9 (tetrahydrofuran); 7732-18-5 (water)

7/8/1118 (Item 9 from file: 73)

EMBASE

(c) 2010 Elsevier B.V. All rights reserved.

0083017899 **EMBASE/MEDLINE No:** 2009245604

### **Bioactive nano-titania ceramics with biomechanical compatibility prepared by doping with piezoelectric BaTiO SUB 3**

**Publication Date:** July 1, 2009

**Drug Descriptors:**

## Appendix A-5. Irrelevant Titles

\* biomaterial

unclassified drug

**Medical Descriptors:**

\* nanotechnology; \*piezoelectricity

animal cell; article; biocompatibility; biological activity; biomechanics; cell culture; cell proliferation; ceramics; controlled **study**; crystallization; doping; **human**; **human tissue**; nonhuman; osteoblast; particle size; priority journal; rat; young modulus

**Drug Terms (Uncontrolled):** barium titanate

**CAS Registry Number:** 12047-27-7, 67290-80-6 (barium titanate)

7/8/1119 (Item 10 from file: 73)

EMBASE

(c) 2010 Elsevier B.V. All rights reserved.

0082932324 **EMBASE/MEDLINE No:** 2009167135

**Synthesis of titania nanosheets with a high percentage of exposed (001) facets and related photocatalytic properties**

**Publication Date:** March 11, 2009

**Drug Descriptors:**

\* nanoparticle; \*titanium dioxide

**Medical Descriptors:**

article; photocatalysis; synthesis; transmission electron microscopy; X ray diffraction

**CAS Registry Number:** 1317-70-0, 1317-80-2, 13463-67-7, 51745-87-0 (titanium dioxide)

7/8/1121 (Item 12 from file: 73)

EMBASE

(c) 2010 Elsevier B.V. All rights reserved.

0082674379 **EMBASE/MEDLINE No:** 2008507974

**Primary study on the antibacterial property of silver-loaded nano- titania coatings**

**Publication Date:** July 29, 2008

**Drug Descriptors:**

\* silver nitrate; \*titanium derivative

alkaline phosphatase--endogenous compound--ec; **water**

**Medical Descriptors:**

antibacterial activity; article; bacterial growth; bacterial survival; bactericidal activity; cell proliferation; controlled study; cytotoxicity; immersion; implant; in vitro study; inhibition kinetics; material coating; minimum inhibitory concentration; osteoblast; **process** optimization; protein expression; scanning electron microscopy; spectrometry;

Staphylococcus aureus; surface property

**CAS Registry Number:** 9001-78-9 (alkaline phosphatase); 7761-88-8 (silver nitrate); 7732-18-5 ( water)

7/8/1123 (Item 14 from file: 73)

EMBASE

(c) 2010 Elsevier B.V. All rights reserved.

## Appendix A-5. Irrelevant Titles

0082471601 EMBASE/MEDLINE No: 2008259193

**Genotoxic and cytotoxic potential of titanium dioxide (TiO SUB 2) nanoparticles on fish cells in vitro**

**Issue Title:** Special issue on Ecotoxicology, Chemistry and Risk Assessment of Nanoparticles. Guest Editors: Richard Handy and Richard Owen.

**Publication Date:** July 1, 2008

**Drug Descriptors:**

\* nanoparticle; \*titanium dioxide

phosphate buffered saline

**Medical Descriptors:**

article; controlled **study**; cytotoxicity; fish; genotoxicity; in vitro **study**; nonhuman; priority journal; rainbow trout; scanning electron microscopy; transmission electron microscopy; ultraviolet radiation

**CAS Registry Number:** 1317-70-0, 1317-80-2, 13463-67-7, 51745-87-0 (titanium dioxide)

7/8/1124 (Item 15 from file: 73)

EMBASE

(c) 2010 Elsevier B.V. All rights reserved.

0082412081 EMBASE/MEDLINE No: 2008215026

**Nano titanium dioxide photocatalytic protein tyrosine nitration: A potential hazard of TiO SUB 2 on skin**

**Publication Date:** June 13, 2008

**Drug Descriptors:**

\* nanoparticle; \*protein tyrosine kinase--endogenous compound--ec; \*titanium dioxide--drug **toxicity--to**

bovine serum albumin

**Medical Descriptors:**

\* nitration; \*photocatalysis; \*skin **toxicity**

animal tissue; article; controlled **study**; mouse; nitrate stress; nonhuman; oxidative stress; priority journal; protein modification; skin disease; ultraviolet irradiation

**CAS Registry Number:** 80449-02-1 (protein tyrosine kinase); 1317-70-0, 1317-80-2, 13463-67-7, 51745-87-0 (titanium dioxide)

7/8/1125 (Item 16 from file: 73)

EMBASE

(c) 2010 Elsevier B.V. All rights reserved.

0082353025 EMBASE/MEDLINE No: 2008163027

**Enhanced photoelectrochemical method for linear DNA hybridization detection using Au-nanoparticle labeled DNA as probe onto titanium dioxide electrode**

**Publication Date:** May 15, 2008

**Drug Descriptors:**

\* gold; \*nanoparticle; \*titanium dioxide

oligonucleotide

**Medical Descriptors:**

\* DNA hybridization; \*DNA probe; \*electrochemistry; \*photochemistry

article; gene targeting; mismatch repair; quantitative analysis; signal transduction

**CAS Registry Number:** 7440-57-5 (gold); 1317-70-0, 1317-80-2, 13463-67-7, 51745-87-0

## Appendix A-5. Irrelevant Titles

(titanium dioxide)

7/8/1126 (Item 17 from file: 73)

EMBASE

(c) 2010 Elsevier B.V. All rights reserved.

0082330516 **EMBASE/MEDLINE No:** 2008136405

**Ordinary and nano-titanium dioxide denture appliances influence caries activity in children: A comparative study**

**Publication Date:** January 1, 2008

**Device Brand Name:** Dentocult SM

**Drug Descriptors:**

\* nanomaterial; \*titanium dioxide

**Medical Descriptors:**

\* dental caries--diagnosis--di; \*denture

article; child **health**; clinical article; clinical **assessment**; comparative **study**; controlled **study**; female; **human**; male; school child; tooth implantation

**CAS Registry Number:** 1317-70-0, 1317-80-2, 13463-67-7, 51745-87-0 (titanium dioxide)

7/8/1128 (Item 19 from file: 73)

EMBASE

(c) 2010 Elsevier B.V. All rights reserved.

0082274517 **EMBASE/MEDLINE No:** 2008069162

**A plasmonic photocatalyst consisting of silver nanoparticles embedded in titanium dioxide**

**Publication Date:** February 6, 2008

**Drug Descriptors:**

\* nanoparticle; \*silver; \*titanium dioxide

methylene blue; silicon dioxide

**Medical Descriptors:**

\* catalyst; \*photocatalysis

article; decomposition; dielectric constant; light **exposure**; oxidation; reaction **analysis**; thickness; ultraviolet irradiation

**Medical Terms (Uncontrolled):** plasmonic photocatalysis

**CAS Registry Number:** 61-73-4 (methylene blue); 10279-57-9, 14464-46-1, 14808-60-7, 15468-32-3, 60676-86-0, 7631-86-9 (silicon dioxide); 7440-22-4 (silver); 1317-70-0, 1317-80-2, 13463-67-7, 51745-87-0 (titanium dioxide)

7/8/1129 (Item 20 from file: 73)

EMBASE

(c) 2010 Elsevier B.V. All rights reserved.

0082100995 **EMBASE/MEDLINE No:** 2008126498

**Hydroxyl radicals ( $\cdot\text{OH}$ ) are associated with titanium dioxide (TiO<sub>2</sub>) nanoparticle-induced cytotoxicity and oxidative DNA damage in fish cells**

**Publication Date:** April 2, 2008

## Appendix A-5. Irrelevant Titles

### Drug Descriptors:

\* hydroxyl radical--drug **toxicity**--to; \*nanoparticle--drug **toxicity**--to; \*titanium dioxide--drug **toxicity**--to

DNA base; DNA formamidopyrimidine glycosylase; endonuclease; free radical; guanine; neutral red; purine

### Medical Descriptors:

\* cytotoxicity; \*DNA damage; \*oxidative stress

animal cell; article; cell viability; comet assay; concentration response; controlled **study**; **dose** response; electron spin resonance; genotoxicity; goldfish; lysosome membrane; membrane structure; nonhuman; particle size; priority journal; qualitative **analysis**; radiation **exposure**; skin cell; spin trapping; ultraviolet A radiation

**CAS Registry Number:** 78783-53-6 (DNA formamidopyrimidine glycosylase); 9055-11-2 (endonuclease); 69257-39-2, 73-40-5 (guanine); 3352-57-6 (hydroxyl radical); 553-24-2 (neutral red); 120-73-0 (purine); 1317-70-0, 1317-80-2, 13463-67-7, 51745-87-0 (titanium dioxide)

7/8/1130 (Item 21 from file: 73)

EMBASE

(c) 2010 Elsevier B.V. All rights reserved.

0081882467 **EMBASE/MEDLINE No:** 2007316662

**Titanium dioxide (TiO SUB 2) nanoparticles filled poly(D,L lactid acid) (PDLA) matrix composites for bone tissue engineering**

**Issue Title:** Special Section: Selected Papers from the EUROMAT 2005 Conference, Prague, September 2005

**Publication Date:** July 1, 2007

### Drug Descriptors:

\* nanoparticle; \*polylactic acid; \*titanium dioxide

hydroxyapatite; nanocrystal

### Medical Descriptors:

\* tissue engineering

**analytic** method; article; body fluid; cell metabolism; cell viability; controlled **study**; cytotoxicity; film; **human**; **human cell**; immersion; priority journal

**CAS Registry Number:** 1306-06-5, 51198-94-8 (hydroxyapatite); 26100-51-6 (polylactic acid); 1317-70-0, 1317-80-2, 13463-67-7, 51745-87-0 (titanium dioxide)

7/8/1131 (Item 22 from file: 73)

EMBASE

(c) 2010 Elsevier B.V. All rights reserved.

0081600725 **EMBASE/MEDLINE No:** 2007034024

**Daphnia magna mortality when exposed to titanium dioxide and fullerene (C SUB 60) nanoparticles**

**Publication Date:** April 1, 2006

### Drug Descriptors:

\* fullerene--drug **toxicity**--to; \*nanoparticle--drug **toxicity** --to; \*titanium dioxide--drug **toxicity**--to

## Appendix A-5. Irrelevant Titles

### Medical Descriptors:

\* **toxicity** testing

animal experiment; animal tissue; aquatic **environment**; article; concentration response; controlled **study**; Daphnia; **environmental exposure**; filtration; image **analysis**; LC 50; mortality; nanotechnology; nonhuman; priority journal; transmission electron microscopy; ultrasound

**CAS Registry Number:** 1317-70-0, 1317-80-2, 13463-67-7, 51745-87-0 (titanium dioxide)

7/8/1132 (Item 23 from file: 73)

EMBASE

(c) 2010 Elsevier B.V. All rights reserved.

0081372851 **EMBASE/MEDLINE No:** 2006435573

**Investigation on the sonocatalytic degradation of parathion in the presence of nanometer rutile titanium dioxide (TiO SUB 2) catalyst**

**Publication Date:** September 21, 2006

### Drug Descriptors:

\* parathion; \*titanium dioxide

ion; nanoparticle; nitrite; phosphate; sulfate

### Medical Descriptors:

\* catalysis; \*catalyst; \*degradation; \*ultrasound

alkalinity; aqueous solution; article; chemical structure; heat treatment; high temperature; irradiation; kinetics; low temperature; organic waste; powder; reaction analysis; waste water management

### Medical Terms (Uncontrolled):

sonocatalytic degradation

**CAS Registry Number:** 14797-65-0 (nitrite); 3270-86-8, 56-38-2, 597-88-6 (parathion); 14066-19-4, 14265-44-2 (phosphate); 14808-79-8 (sulfate); 1317-70-0, 1317-80-2, 13463-67-7, 51745-87-0 (titanium dioxide)

7/8/1133 (Item 24 from file: 73)

EMBASE

(c) 2010 Elsevier B.V. All rights reserved.

0080312641 **EMBASE/MEDLINE No:** 2004498459

**Highly efficient dye-sensitized solar cells with a titania thin-film electrode composed of a network structure of single-crystal-like TiO SUB 2 nanowires made by the "oriented attachment" mechanism**

**Publication Date:** November 17, 2004

### Drug Descriptors:

\* dye; \*titanium; \*titanium dioxide

acetylacetone; nanoparticle; surfactant

### Medical Descriptors:

\* crystal structure; \*film

adsorption; article; crystallization; electrode; electron **transport**; energy; low temperature; materials

**CAS Registry Number:** 123-54-6 (acetylacetone); 1317-70-0, 1317-80-2, 13463-67-7,

## Appendix A-5. Irrelevant Titles

51745-87-0 ( titanium dioxide); 7440-32-6 (titanium)

7/8/1134 (Item 25 from file: 73)

EMBASE

(c) 2010 Elsevier B.V. All rights reserved.

0079621395 EMBASE/MEDLINE No: 2003329419

**Controlled formation of highly organized mesoporous titania thin films: From mesostructured hybrids to mesoporous nanoanatase TiO SUB 2**

**Publication Date:** August 13, 2003

**Drug Descriptors:**

\* titanium dioxide

ethylene oxide derivative; metal oxide; unclassified drug

**Medical Descriptors:**

\* film

article; heat treatment; nuclear magnetic resonance; spectroscopy; synthesis; technique; ultraviolet radiation

**Drug Terms (Uncontrolled):** poly(ethylene oxide)

**CAS Registry Number:** 1317-70-0, 1317-80-2, 13463-67-7, 51745-87-0 (titanium dioxide)

7/8/1135 (Item 26 from file: 73)

EMBASE

(c) 2010 Elsevier B.V. All rights reserved.

0078736083 EMBASE/MEDLINE No: 2001342416

**Nanoparticle routes to mesoporous titania thin films**

**Publication Date:** September 21, 2001

**Drug Descriptors:**

\* titanium dioxide

copolymer; nanoparticle

**Medical Descriptors:**

article; film; porosity; reaction analysis; synthesis; X ray diffraction

**CAS Registry Number:** 1317-70-0, 1317-80-2, 13463-67-7, 51745-87-0 (titanium dioxide)

7/8/1137 (Item 2 from file: 76)

Environmental Sciences

(c) 2009 CSA. All rights reserved.

0002313558 IP Accession No: 9284677

**Antimicrobial Activity of Titanium Dioxide Nanoparticles Synthesized by Sol-Gel Technique**

**Publication Date: 2009**

**Descriptors:** Antimicrobial activity; Energy; Illumination; Light effects; Microorganisms; Titanium dioxide; U.V. radiation; nanoparticles; Escherichia coli; Klebsiella pneumoniae; Pseudomonas aeruginosa; Staphylococcus aureus

## Appendix A-5. Irrelevant Titles

**Subj Catg:** 01340, Antibiotics & Antimicrobials; 02450, Ecology

7/8/1138 (Item 3 from file: 76)

Environmental Sciences

(c) 2009 CSA. All rights reserved.

0002239818 IP Accession No: 8751871

**Nano-titania assisted photoreduction of Cr(VI): The role of the different TiO sub(2) polymorphs**

**Publication Date: 2008**

**Descriptors:** Alcohol; Catalysis; Kinetics; Salts; Slurries; Sodium; Thermodynamics ; composite materials; pH; surface area

**Subj Catg:** 40, Water Pollution: Monitoring, Control & Remediation

7/8/1139 (Item 4 from file: 76)

Environmental Sciences

(c) 2009 CSA. All rights reserved.

0002227421 IP Accession No: 8683081

**Pt/titania-nanotube: A potential catalyst for CO sub(2) adsorption and hydrogenation**

**Publication Date: 2008**

**Descriptors:** Adsorption; Carbon dioxide; Catalysis; Catalysts; Desorption; Methane; Microscopy; Photochemicals; Physicochemical properties; Spectroscopy; X-ray diffraction; low temperature; surface area

**Subj Catg:** 10, General Environmental Engineering

7/8/1140 (Item 5 from file: 76)

Environmental Sciences

(c) 2009 CSA. All rights reserved.

0002113916 IP Accession No: 7967734

**Photocatalysis of methylene blue on titanium dioxide nanoparticles synthesized by modified sol-hydrothermal process of TiCl sub(4)**

**Publication Date: 2007**

**Descriptors:** Absorbance; Biodegradation; Catalysis; Condensation; Economics; Energy ; Hydrolysis; I.R. spectroscopy; Methylene blue; Photodegradation; Powder; Scanning electron microscopy; Solvents; Titanium; Titanium dioxide; Transmission electron microscopy; Wavelength; X-ray diffraction ; alcohols; nanoparticles

**Subj Catg:** 01450, Environmental Pollution & Waste Treatment

7/8/1141 (Item 6 from file: 76)

Environmental Sciences

(c) 2009 CSA. All rights reserved.

0002077363 IP Accession No: 8105184

## Appendix A-5. Irrelevant Titles

### **Study on Influencing Factors for Degradation of Dimethoate Solution by Nanosized Titanium Dioxide Photocatalysis**

**Publication Date: 2007**

**Descriptors:** Degradation; **Environmental** degradation; Irradiation; Oxidants; Photochemicals; Photodegradation; Titanium; Ultrasonics; Wastewater; dimethoate; titanium dioxide

**Subj Catg:** 50, Water & Wastewater Treatment; 3040, Wastewater treatment processes

7/8/1142 (Item 7 from file: 76)

Environmental Sciences

(c) 2009 CSA. All rights reserved.

0001931285 IP Accession No: 6028104

### **Studies on the Photocatalytic Degradation of Reactive Brilliant Red X-3B in Water by Nanometer Titanium Dioxide**

**Publication Date: 2002**

**Descriptors:** Acids; Behavior; Catalysts; Degradation; Dye Concentrations; Ecology; Hydrogen Ion Concentration; Kinetics; Light Intensity; Light intensity; Titanium; Ultraviolet radiation

**Subj Catg:** 01521, Mechanical and natural changes; 50, Water & Wastewater Treatment

7/8/1143 (Item 8 from file: 76)

Environmental Sciences

(c) 2009 CSA. All rights reserved.

0001846941 IP Accession No: 5955721

### **Selective Separation of La super(3+) and Lanthanum Organic Complexes with Nanometer-Sized Titanium Dioxide and Their Detection by Using Fluorination-Assisted Electrothermal Vaporization ICP-AES with In-Situ Matrix Removal**

**Publication Date: 2004**

**Descriptors:** titanium dioxide; Fluoride; Vaporization; Lanthanum; Separation **processes**; Furnaces; Humic acids; pH

**Subj Catg:** 20, Air Pollution: Monitoring, Control & Remediation

7/8/1144 (Item 1 from file: 95)

TEME-Technology & Management

(c) 2010 FIZ TECHNIK. All rights reserved.

02485375 20090904694

**A novel magnetic nanocomposite involving anatase titania coating on silica-modified cobalt ferrite via lower temperature hydrolysis of a water-soluble titania precursor** ( Erzeugung einer neuartigen magnetischen **Nanokompositbeschichtung** mit Anatas auf einem mit Silica modifizierten Cobaltferrit mittels Niedrigtemperatur-Hydrolyse einer wasserloeslichen **Titania**-Vorstufe ) , **2009**

**Descriptors:** ANATASE; TITANIUM DIOXIDE; SILICA--SILICEOUS EARTH; COBALT FERRITE; MAGNETIC CHARACTERISTICS; X RAY DIFFRACTION; PES--PHOTOELECTRON SPECTROSCOPY; CATALYSIS

## Appendix A-5. Irrelevant Titles

**Identifiers:** NANOKOMPOSIT; Cobaltferrit; Nanokomposit; Titandioxid; Silica; magnetische Eigenschaft

7/8/1145 (Item 2 from file: 95)  
TEME-Technology & Management  
(c) 2010 FIZ TECHNIK. All rights reserved.  
02482954 20090803194

**Dye-sensitized solar cell based on titania nanofibers produced by electrospinning, 2009**

**Descriptors:** NANOFIBERS; SUBSTITUTES--GENERAL; ELECTRIC FIELD; SPINNING--TEXTILE **PROCESS**; TITANIUM OXIDES; SOLAR BATTERIES; POLY VINYL PYRROLIDONE; LIGHT ABSORPTION; CONVERSION--GENERAL

**Identifiers:** NANOTEILCHEN; Solarzelle; Nanofaser

7/8/1146 (Item 3 from file: 95)  
TEME-Technology & Management  
(c) 2010 FIZ TECHNIK. All rights reserved.  
02457048 20090608930

**Bioactive nano-titania ceramics with biomechanical compatibility prepared by doping with piezoelectric BaTiO<sub>3</sub>**

( Bioaktive **nanokristalline** Titandioxid-Keramik mit biomechanischer Kompatibilitaet durch Dotieren mit piezoelektrischem BaTiO<sub>3</sub> ), **2009**

**Descriptors:** NANOCERAMICS; DOPING--**PROCESS**; PIEZOCERAMICS; BARIUM TITANATE; CRYSTAL GROWTH; SINTERING; ELASTIC MODULUS; BONES--ANATOMY; BIOACTIVITY; ADDITIVES; INHIBITOR--MATERIAL; CELL CULTURES; TITANIUM DIOXIDE

**Identifiers:** KRISTALLWACHSTUM INHIBITOR; nanokristalline Titandioxid-Keramik; piezoelektrisches BaTiO<sub>3</sub>; Inhibitor

7/8/1148 (Item 5 from file: 95)  
TEME-Technology & Management  
(c) 2010 FIZ TECHNIK. All rights reserved.  
02444911 20090401765

**Biocompatible electrospun titania-composite nanofiber networks for whole cell sensing, 2008**

**Descriptors:** BIOSENSORS; TITANIUM OXIDES; NANOFIBERS; IMPEDANCE SPECTROMETRY

**Identifiers:** ELEKTROSPINNEN; Elektrospinnen; Titanoxid-Nanofaser

7/8/1149 (Item 6 from file: 95)  
TEME-Technology & Management  
(c) 2010 FIZ TECHNIK. All rights reserved.

## Appendix A-5. Irrelevant Titles

02440646 20080402999

**Vertically oriented titania nanotubes prepared by anodic oxidation on Si substrates**

( Herstellung vertikal orientierter Titandioxid-Nanoroehrchen durch anodische Oxidation auf Si-Substraten ) , **2008**

**Descriptors:** TITANIUM OXIDES; NANOTUBES; FABRICATION METHOD; ANODIC OXIDATION; SI SUBSTRATES; ORIENTATION--GENERAL; POROSE MATERIALS; ROOM TEMPERATURE TEST; METAL FILMS; TITANIUM; AQUEOUS SOLUTIONS; SODIUM SULFATE; CITRIC ACID; CURRENT DENSITY; SCANNING ELECTRON MICROSCOPY

**Identifiers:** VERTIKALE ORIENTIERUNG; Titanoxid-Nanoroehrchenherstellung; anodische Oxidation

7/8/1150 (Item 7 from file: 95)

TEME-Technology & Management

(c) 2010 FIZ TECHNIK. All rights reserved.

02440264 20090403971

**Development of ceramic composite coatings with titania nanofibers**

( Entwicklung keramischer Verbundbeschichtungen mit Titanoxid- Nanofasern ) , **2008**

**Descriptors:** AL SUB 2 O SUB 3 ; TITANIUM OXIDES; NANOCERAMICS; COMPOSITE CERAMICS; NANOPARTICLES; NANOFIBERS; BREAKING RESISTANCE; MICROSTRUCTURE; FRACTURE TOUGHNESS; HOT SPRAYING; VICKERS HARDNESS; CRACK GROWTH

**Identifiers:** ATMOSPHAERISCHES PLASMASPRITZEN; Al<sub>2</sub>O<sub>3</sub>-TiO<sub>2</sub>-Verbundbeschichtung; Plasmaspritzen; Titanoxidnanofaser

7/8/1151 (Item 8 from file: 95)

TEME-Technology & Management

(c) 2010 FIZ TECHNIK. All rights reserved.

02368514 20080900741

**Synthesis of titania/carbon nanocomposites by polymeric precursor method**

( Synthese von TiO<sub>2</sub>/Kohlenstoffnanoverbundwerkstoffen mit Hilfe eines polymeren Vorprodukts ) , **2008**

**Descriptors:** SYNTHESIS--GENERAL; NANOPARTICLES; TITANIUM OXIDES; CARBON; AMORPHOUS MATERIALS; CRYSTALLINE MATERIALS; NANOCOMPOSITE MATERIALS; GRAIN SIZE; PHOTOCATALYSIS; CATALYSTS--REACTION ACCELERATOR; RHODAMINE; CHEMICAL DEGRADATION; MATERIALS STRUCTURE; HEAT UP--GENERAL; ANATASE; RUTILE-- MINERAL

**Identifiers:** Ni-TiO<sub>2</sub>-C-Nanoverbundwerkstoff; Struktur; Photokatalyse; Erwaermen; Anatas; Rutil

7/8/1152 (Item 9 from file: 95)

TEME-Technology & Management

(c) 2010 FIZ TECHNIK. All rights reserved.

## Appendix A-5. Irrelevant Titles

02357492 20080700170

### **Sol-gel-microemulsion titania nanoparticles and its performance in photocatalytic oxidation of acetic acid**

( Sol-Gel-Mikroemulsion von Titandioxid-Nanopartikeln und ihre Wirksamkeit bei der photokatalytischen Oxidation der Essigsaeure ) , 2008

**Descriptors:** PHOTOCATALYSIS; SOL GEL **PROCESS**; RUTILE--MINERAL; ANATASE; ACETIC ACID; REVERSE MICELLE; X RAY DIFFRACTION; NANOPARTICLES; HETEROGENEOUS CATALYSIS; CATALYST ACTIVITY; CATALYTIC OXIDATION

**Identifiers:** HETEROGENE PHOTOKATALYSE; TiO<sub>2</sub>-Nanopartikel; Sol-Gel-Weg; Photokatalyse; Oxidation

7/8/1153 (Item 10 from file: 95)

TEME-Technology & Management

(c) 2010 FIZ TECHNIK. All rights reserved.

02344075 20080611074

### **Photocatalytic hydrogen production using surface-modified titania nanoparticles , 2007**

**Descriptors:** CADMIUM COMPOUNDS; CATALYSIS; HYDROGEN STORAGE; 2 6 COMPOUNDS; NANOCOMPOSITE MATERIALS; NANOPARTICLES; PHOTOCHEMISTRY; SEMICONDUCTOR QUANTUM DOTS; TITANIUM COMPOUNDS; TITANIUM DIOXIDE; ULTRAVIOLET **EXPOSURE**; ELECTROSTATIC ATTRACTION; QUANTUM DOTS; ILLUMINATION

**Identifiers:** WASSERSTOFFWIRTSCHAFT; ORGANISCHES SUBSTRAT; Cadmiumverbindung; Katalyse

7/8/1154 (Item 11 from file: 95)

TEME-Technology & Management

(c) 2010 FIZ TECHNIK. All rights reserved.

02344072 20080611077

### **Photocatalytic hydrogen production over CdS/titania- nanotube composite films , 2007**

**Descriptors:** CADMIUM COMPOUNDS; CATALYSIS; HYDROGEN STORAGE; 2 6 COMPOUNDS; NANOCOMPOSITE MATERIALS; NANOTUBES; PHOTOCHEMISTRY; PHOTOCONDUCTIVITY; TITANIUM COMPOUNDS; HYDROTHERMAL REACTION; PHOTOCATALYSIS; PHOTOCURRENT; ELECTRIC ENERGY GENERATION; CRYSTALLINITY

**Identifiers:** KRISTALLWACHSTUM AUS DER LOESUNGSPHASE; WASSERSTOFFWIRTSCHAFT; Cadmiumverbindung; Katalyse

7/8/1155 (Item 12 from file: 95)

TEME-Technology & Management

## Appendix A-5. Irrelevant Titles

(c) 2010 FIZ TECHNIK. All rights reserved.

02336475 20080209956

**Photocatalytic H<sub>2</sub> production from methanol aqueous solution over titania nanoparticles with mesostructures**, 2008

**Descriptors:** HYDROGEN; PHOTOCATALYSIS; SOLAR ENERGY; DIRECT ENERGY CONVERSION; TITANIUM DIOXIDE; NANOPARTICLES; METHYL ALCOHOL; PRETREATMENT; CALCINATION; PLATINUM ; CATALYST SUPPORT; CATALYST ACTIVITY

**Identifiers:** PHOTOKATALYTISCHE WASSERSTOFFPRODUKTION; photokatalytische Wasserstoffproduktion; Methanol; Titandioxid; Nanopartikel

7/8/1156 (Item 13 from file: 95)

TEME-Technology & Management

(c) 2010 FIZ TECHNIK. All rights reserved.

02333186 20080600987

**Effect of carbon doping on the mesoporous structure of nanocrystalline titanium dioxide and its solar-light-driven photocatalytic degradation of NO(x)**

( Einfluss einer Kohlenstoff-Dotierung auf die mesoporoese Struktur von **nanokristallinem** Titandioxid und dem Sonnenlicht-induzierten photokatalytischen Abbau von NO(x) ), 2008

**Descriptors:** TITANIUM OXIDES; NANOCRYSTALLINE MATERIALS; DOPING--PROCESS; CARBON ADDITION; FABRICATION METHOD; CARBONIZATION; TITANIUM COMPOUNDS; CHLORIDES; ABSORPTION SPECTRUM; CHEMICAL DEGRADATION; NITRIC OXIDES; EFFECT OF SUNLIGHT; PHOTOCATALYSIS; NOXIOUS AGENTS; POROUS CATALYST; INDOOR AIR TECHNIQUE; NANOTUBES

**Identifiers:** nanokristallines TiO<sub>2</sub>; C-Dotierung; Photokatalysator

7/8/1157 (Item 14 from file: 95)

TEME-Technology & Management

(c) 2010 FIZ TECHNIK. All rights reserved.

02321221 20080405839

**Toughening of nanotransformable t'-YSZ by addition of titania**

( Zaehigkeitserhoehung bei nichttransformierbarem t'-YSZ durch Zusatz von Titanoxid ), 2007

**Descriptors:** YTTRIA STABILIZED ZIRCONIUM OXIDE; REPLACEMENT; TITANIUM OXIDES; TITANIUM ION; MINERALOGICAL COMPOSITION; TETRAGONAL CRYSTAL SYSTEM; FERRO ELASTICITY ; TOUGHNESS; SCANNING ELECTRON MICROSCOPY; HEAT TREATING--MATERIALS; THERMAL BARRIER COATINGS; GAS TURBINES; TEM--TRANSMISSION ELECTRON MICROSCOPY; VICKERS HARDNESS; GRAIN SIZE; MICROSTRUCTURE; CRACK GROWTH; LATTICE PARAMETERS; RAMAN SPECTRA; X RAY DIFFRACTION

**Identifiers:** Zirkoniumoxid; TiO<sub>2</sub>-Substitution; Kristallstruktur; Phasendiagramm;

## Appendix A-5. Irrelevant Titles

Zaehigkeit

7/8/1158 (Item 15 from file: 95)

TEME-Technology & Management

(c) 2010 FIZ TECHNIK. All rights reserved.

02318000 20080406182

**A novel electrogenerated chemiluminescence (ECL) sensor based on Ru(bpy)<sub>3</sub>(2+)-doped titania nanoparticles dispersed in nafion on glassy carbon electrode**

( Ein neuartiger elektrochemischer Chemilumineszenz-Sensor (ECL) auf Basis von auf einer Glascarbonatelektrode in Nafion dispergierten Ru(bpy)<sub>3</sub>(2+)-dotierten Titanoxid-

**Nanopartikeln ) , 2008**

**Descriptors:** CHEMILUMINESCENCE; RUTHENIUM COMPOUNDS; NANOPARTICLES; TITANIUM DIOXIDE; IONIC POLYMERS; GLASSY CARBON; EMULSION POLYMERIZATION; IMMOBILIZATION; CHEMOELECTRICAL SENSORS; **DETECTION LIMIT**

**Identifiers:** elektrochemischer Chemilumineszenz-Sensor; dotiertes Nanotitanoxid

7/8/1159 (Item 16 from file: 95)

TEME-Technology & Management

(c) 2010 FIZ TECHNIK. All rights reserved.

02262316 20070408272

**Fatigue and mechanical properties of nanostructured and conventional titania (TiO<sub>2</sub>) thermal spray coatings**

**, 2007**

**Descriptors:** FRACTURE APPEARANCE; ENDURANCE STRENGTH; FATIGUE LIFE; FATIGUE CRACK; LOW CARBON STEEL; ARC FLAME SPRAYING; HIGH VELOCITY AIR FUEL; MECHANICAL MATERIAL PROPERTIES; NANOSTRUCTURE; SCANNING ELECTRON MICROSCOPY; CRACK FORMATION; CRACK GROWTH; HIGH VELOCITY OXY FUEL; VIBRATION FATIGUE; TITANIUM DIOXIDE; VICKERS HARDNESS

**Identifiers:** NANO TiO<sub>2</sub> FILMABSCHIEDUNG; kohlenstoffarmer Stahl; nano-TiO<sub>2</sub>-Filmabscheidung; Materialermuedung

7/8/1160 (Item 17 from file: 95)

TEME-Technology & Management

(c) 2010 FIZ TECHNIK. All rights reserved.

02253792 20071007646

**Synthesis, structural and electrical characterization of PbS NCs in titania sol-gel films**

( Synthese, strukturelle und elektrische Eigenschaft halbleitender PbS- **Nanokristalle** (NCs) in Titanoxid-Sol-Gel-Schichten ) , **2007**

**Descriptors:** LEAD SULFIDE; NANOCRYSTALLINE MATERIALS; CLUSTER--GENERAL; SOL GEL **PROCESS**; HIGH RESOLUTION TRANSMISSION ELECTRON MICROSCOPY; SCANNING ELECTRON MICROSCOPY; AFM--ATOMIC FORCE MICROSCOPY; OPTICAL PROPERTIES; RHODANIDES; ELECTRIC TENSION; SOL

## Appendix A-5. Irrelevant Titles

### GEL FILMS

**Identifiers:** halbleitendes PbS-Nanokristall; Sol-Gel-Schicht; Struktur

7/8/1161 (Item 18 from file: 95)

TEME-Technology & Management

(c) 2010 FIZ TECHNIK. All rights reserved.

02242065 20070905301

**Superhydrophilicity and photocatalytic property of nanocrystalline titania sol-gel films , 2007**

**Descriptors:** AFM--ATOMIC FORCE MICROSCOPY; CATALYSIS; CRYSTAL STRUCTURE; DIP COATING; GELS; NANOCRYSTALLINE MATERIALS; PHOTOCHEMISTRY; RAMAN SPECTRA; SOL-- COLLOID; ROUGHNESS; THIN COATINGS; TITANIUM COMPOUNDS; ULTRAVIOLET **EXPOSURE**; RADIATION EFFECT; X RAY DIFFRACTION; TITANIUM DIOXIDE; GLASS SUBSTRATE; PHOTOCATALYSIS

**Identifiers:** Atomkraftmikroskopie; Katalyse

7/8/1162 (Item 19 from file: 95)

TEME-Technology & Management

(c) 2010 FIZ TECHNIK. All rights reserved.

02239244 20070307409

**Synthesis, characterization and measurements of electrical properties of alumina-titania nano-composites**

( Synthese und Charakterisierung sowie Messung der elektrischen Eigenschaften von Aluminiumoxid-Titandioxid-**Nanoverbundstoffen** ) , 2007

**Descriptors:** NANOCOMPOSITE MATERIALS; ELECTRONIC APPLIANCES; AL SUB 2 O SUB 3 ; MATERIAL PROPERTIES; TITANIUM OXIDES; SOL GEL **PROCESS**; MICROGELS; AMORPHOUS MATERIALS; HEAT TREATING--MATERIALS; X RAY DIFFRACTION; HIGH RESOLUTION TRANSMISSION ELECTRON MICROSCOPY; POWDER COMPACTION; FRITTING; MINERALOGICAL COMPOSITION; DENSIFICATION--GENERAL; DIELECTRIC PROPERTIES; DISSIPATION FACTOR; ALUMINIUM TITANATE

**Identifiers:** Nanoverbund; Aluminiumtitanoxid; dielektrische Eigenschaft

7/8/1163 (Item 20 from file: 95)

TEME-Technology & Management

(c) 2010 FIZ TECHNIK. All rights reserved.

02236292 20070804191

**Titanium dioxide (TiO<sub>2</sub>) nanoparticles filled poly(D,L lactid acid) (PDLLA) matrix composites for bone tissue engineering**

( Mit Titandioxid (TiO<sub>2</sub>)-**Nanopartikeln** gefuellte PDLLA-Filme fuer die Knochenregeneration ) , 2007

**Descriptors:** NANOPARTICLES; TITANIUM DIOXIDE; POLY LACTID ACID; TISSUE REGENERATION; BONES--ANATOMY; CYTOTOXICITY; HYDROXYAPATITE;

## Appendix A-5. Irrelevant Titles

IMMERSE--FLUID; BIOACTIVITY; COMPOSITE MATERIALS; POLYMER FILMS;  
CRYSTALLISATION; BIOMIMETIC **PROCESS**; IN VITRO; FIELD ELECTRON  
MICROSCOPES; SURFACE TOPOGRAPHY

**Identifiers:** SIMULIERTE KOERPERFLUESSIGKEIT; OSTEOBLASTEN; POLY DL  
LACTID; Titandioxidnanopartikel; Polylactidfilm; Bioaktivitaet

7/8/1164 (Item 21 from file: 95)

TEME-Technology & Management

(c) 2010 FIZ TECHNIK. All rights reserved.

02232373 20070800628

**Preparation, characterization and photocatalytic activity of TiO<sub>2</sub> / methylcellulose  
nanocomposite films derived from nanopowder TiO<sub>2</sub> and modified sol-gel titania**

( Herstellung, Charakterisierung und photokatalytische Aktivitaet von TiO<sub>2</sub>/Methylcellulose-

**Nanoverbundwerkstoff-Duennschichten - hergestellt aus TiO<sub>2</sub>-Nanopulver und  
modifiziertem Sol-Gel-Titandioxid ) , 2007**

**Descriptors:** ANATASE; PHOTOCATALYSIS; CATALYST ACTIVITY;  
NANOCOMPOSITE MATERIALS; THIN COATINGS; SOL GEL **PROCESS**;  
FABRICATION METHOD; SPIN COATING; GLASS SUBSTRATE; ROUGH SURFACE;  
HEAT TREATING--MATERIALS; HARDNESS; PHOTOCHEMICAL DEGRADATION;  
ORGANIC POLLUTANT; ADHESION STRENGTH; NANO POWDERS

**Identifiers:** Nanoverbundwerkstoff; Anatas; Methylcellulose; Beschichtung;  
Photokatalysator

7/8/1165 (Item 22 from file: 95)

TEME-Technology & Management

(c) 2010 FIZ TECHNIK. All rights reserved.

02226744 20070708382

**Photochromic silver nanoparticles in titania  
, 2007**

**Descriptors:** ELECTRON EMISSION; NANOPARTICLES; SILVER; TITANIUM  
COMPOUNDS; TITANIUM OXIDES; OPTICAL MEASUREMENT; LASER  
IRRADIATED; TITANIUM DIOXIDE

**Identifiers:** OBERFLAECHEPLASMONSCHWINGUNG; OPTISCHE  
SPEKTROSKOPIE; Elektronenemission; Nanopartikel

7/8/1166 (Item 23 from file: 95)

TEME-Technology & Management

(c) 2010 FIZ TECHNIK. All rights reserved.

02225476 20070704914

**Synthesis and characterization of titania and rare earth doped titania nanoparticles by  
sol-gel process  
, 2006**

**Descriptors:** HYDROLYSIS; PHASE CHANGE; X RAY DIFFRACTION;

## Appendix A-5. Irrelevant Titles

LANTHANIDES; SOL GEL **PROCESS**; TEM--TRANSMISSION ELECTRON MICROSCOPY; TITANIUM DIOXIDE; ULTRAVIOLET RESISTANCE; ULTRAVIOLET SPECTROMETRY

**Identifiers:** Seltene Erden; Sol-Gel-Verfahren; Titannanopartikel

7/8/1167 (Item 24 from file: 95)

TEME-Technology & Management

(c) 2010 FIZ TECHNIK. All rights reserved.

02220679 20070702245

**Multistep loading of titania nanoparticles in the mesopores of SBA-15 for enhanced photocatalytic activity**

( Mehrstufige Einlagerung von Titandioxid-**Nanopartikel** in die Mesoporen von SBA-15 fuer eine verstaerkte photokatalytische Aktivitaet ) , **2007**

**Descriptors:** ANATASE; NANOPARTICLES; CHEMICAL SYNTHESIS; SOL GEL **PROCESS**; PORE STRUCTURE; CATALYST ACTIVITY; PHOTOCATALYSIS; RHODAMINE

**Identifiers:** Anatas-Nanopartikel; Mesoporeneinlagerung; Photokatalyse

7/8/1168 (Item 25 from file: 95)

TEME-Technology & Management

(c) 2010 FIZ TECHNIK. All rights reserved.

02218266 20070700207

**Preparation and characterization of poly(imide siloxane) (PIS)/ titania(TiO<sub>2</sub>) hybrid nanocomposites by sol-gel processes**  
, **2007**

**Descriptors:** AFM--ATOMIC FORCE MICROSCOPY; CHEMICAL SYNTHESIS; STRAIN MEASUREMENT; DIFFERENTIAL SCANNING CALORIMETRY; DMTA--DYNAMIC MECHANICAL THERMAL ANALYSIS; FOURIER TRANSFORM INFRARED SPECTROSCOPY; GLASS TRANSITION TEMPERATURE; HYBRID COMPOSITES; MINERAL FILLER; NANOCOMPOSITE MATERIALS; LIGHT TRANSMISSION; POLYIMIDE RESINS; POLYMER **PROCESSING**; PMC-- POLYMER MATRIX COMPOSITES; REACTION MECHANISM; X RAY PHOTOELECTRON SPECTROMETRY; SILOXANE; SOL GEL **PROCESS**; THERMOGRAVIMETRIC ANALYSIS; TITANIUM DIOXIDE; TEM--TRANSMISSION ELECTRON MICROSCOPY; HEAT RESISTANCE; YOUNG MODULUS; PULL STRENGTH

**Identifiers:** POLYDIMETHYLDIPHENYLSILOXAN; POLYIMIDSILOXAN; TIO<sub>2</sub> NANOPARTIKELVERSTAERKUNG ; Polyimidsiloxan; TiO<sub>2</sub>-Nanopartikelverstaerkung; Materialeigenschaft

7/8/1169 (Item 26 from file: 95)

TEME-Technology & Management

(c) 2010 FIZ TECHNIK. All rights reserved.

## Appendix A-5. Irrelevant Titles

02217699 20070604881

### **Dye-sensitized solar cell architecture based on indium-tin oxide nanowires coated with titanium dioxide**

( Farbstoffsensibilisierte Solarzellenarchitektur auf der Basis von Indiumzinnoxid-Nanodrahten, die beschichtet sind mit Titandioxid ) , 2007

**Descriptors:** SOLAR BATTERIES; ELECTRODES; NANOWIRES; INDIUM TIN OXIDE; 3D OBJECTS; MONOCRYSTAL; COATING TECHNIQUE; NANOCRYSTALLINE MATERIALS; TITANIUM DIOXIDE ; GLASS SUBSTRATE; LIME SODA GLASS; LASER ABLATION; RADIO FREQUENCY SPUTTERING; **PROCESS DESIGN**; **PROCESS PARAMETERS**; SENSITIZATION --GENERAL; DYE UPTAKE; MICROSTRUCTURE; CURRENT VOLTAGE CHARACTERISTICS; TEM --TRANSMISSION ELECTRON MICROSCOPY; X RAY DIFFRACTION; CAPABILITY STUDY

**Identifiers:** TiO<sub>2</sub>-Solarzelle; 3D-Elektrode; Machbarkeitstest

7/8/1170 (Item 27 from file: 95)

TEME-Technology & Management

(c) 2010 FIZ TECHNIK. All rights reserved.

02202618 20070407342

### **Bilirubin adsorption on nanocrystalline titania films** , 2007

**Descriptors:** BIOCHEMISTRY; BIOCOMPATIBLE MATERIALS; DISSOCIATION; INFRARED SPECTRA; NANOCRYSTALLINE MATERIALS; PH NUMBER; PHOTOCHEMISTRY; SEMICONDUCTING MATERIALS; SEMICONDUCTOR THIN FILMS; TITANIUM COMPOUNDS; ULTRAVIOLET **EXPOSURE**; RADIATION EFFECT; ULTRAVIOLET SPECTRA; LIGHT; HYDOXYL ION; CHEMICAL DECOMPOSITION; TITANIUM DIOXIDE; PHYSICAL CHEMISTRY

**Identifiers:** QUARZKRISTALLMIKROWAAGE; Adsorption; Biochemie

7/8/1171 (Item 28 from file: 95)

TEME-Technology & Management

(c) 2010 FIZ TECHNIK. All rights reserved.

02197884 20070304031

### **Synthesis of titanium dioxide photocatalyst with tunable nanoporosity using supercritical fluids** , 2006

**Descriptors:** TITANIUM DIOXIDE; PHOTOCATALYSIS; PORE SIZE DISTRIBUTION; POROSITY; NANOSTRUCTURE; SOL GEL **PROCESS**; SUPERCRITICAL OPERATING AREA; DEHUMIDIFICATION; CALCINATION; CRYSTAL STRUCTURE

**Identifiers:** Titandioxid-Photokatalysator; Nanoporositaet; Sol-Gel-Prozess

7/8/1172 (Item 29 from file: 95)

TEME-Technology & Management

(c) 2010 FIZ TECHNIK. All rights reserved.

## Appendix A-5. Irrelevant Titles

02190161 20061108334

**Preparation of inorganic-organic hybrid titania sol-gel nanocomposite films, and their dielectric properties**  
**, 2006**

**Descriptors:** DIELECTRIC LAYERS; FOURIER TRANSFORM SPECTRA; INFRARED SPECTRA; NANOCOMPOSITE MATERIALS; NANOPARTICLES; ORGANIC INORGANIC HYBRID MATERIALS; DIELECTRIC CONSTANT; PHASE SEPARATION; SCANNING ELECTRON MICROSCOPY; SOL GEL **PROCESS**; TITANIUM COMPOUNDS; TEM--TRANSMISSION ELECTRON MICROSCOPY; X RAY DIFFRACTION; DIELECTRIC PROPERTIES; HYDROLYSIS; CONDENSATION POLYMERISATION; AGEING--MATERIALS; CRYSTAL PHASE; MICROSTRUCTURE; TITANIUM DIOXIDE

**Identifiers:** 80 GRAD C BEREICH; Dielektrische Schicht; Fourier-Transformationesspektrum

7/8/1173 (Item 30 from file: 95)

TEME-Technology & Management

(c) 2010 FIZ TECHNIK. All rights reserved.

02181785 20070308764

**Microwave dielectric behavior of nanocrystalline titanium dioxide thin films**  
**, 2007**

**Descriptors:** AFM--ATOMIC FORCE MICROSCOPY; DIELECTRIC LOSS; DIELECTRIC LAYERS; ENERGY GAP; NANOCRYSTALLINE MATERIALS; DIELECTRIC CONSTANT; INDEX OF REFRACTION; SCANNING ELECTRON MICROSCOPY; SPUTTER DEPOSITION; TITANIUM COMPOUNDS; DC-- DIRECT CURRENT; MAGNETRON SPUTTER DEPOSITION; DISTURBANCE VARIABLE FEEDFORWARD; BAND GAP; DIELECTRIC PROPERTIES; SCANNING ELECTRON MICROSCOPES ; TITANIUM DIOXIDE

**Identifiers:** MIKROWELLENWERKSTOFF; Atomkraftmikroskopie; Dielektrischer Verlustfaktor

7/8/1174 (Item 31 from file: 95)

TEME-Technology & Management

(c) 2010 FIZ TECHNIK. All rights reserved.

02177824 20070209750

**Metal ions incorporated titania nanotubes for hydrocarbon oxidation**  
**, 2006**

**Descriptors:** ACETALDEHYDE; DECONTAMINATION; ENERGY DISPERSIVE X RAY SPECTROMETRY; GOLD ION; HIGH RESOLUTION TRANSMISSION ELECTRON MICROSCOPY; CATALYST ACTIVITY; CATALYST **PRODUCTION**; CATALYTIC OXIDATION; HYDROCARBONS; NANOPARTICLES; NANOTUBES; PHOTOCATALYSIS; PLATINUM ION; STEM--SCANNING TRANSMISSION ELECTRON MICROSCOPY; TITANIUM OXIDES

**Identifiers:** Katalysatoraktivitaet; Titanoxid; Platinion

## Appendix A-5. Irrelevant Titles

7/8/1175 (Item 32 from file: 95)  
TEME-Technology & Management  
(c) 2010 FIZ TECHNIK. All rights reserved.  
02130596 20050102026

**Titanium dioxide nanofibers prepared by using electrospinning method**

( Titandioxidnanofasern, hergestellt durch Elektrospinnen ) , **2004**

**Descriptors:** NANOFIBERS; NANO SYSTEM TECHNOLOGY; TITANIUM DIOXIDE;  
CALCINATION; HYBRID FIBERS; FIBER PROPERTIES; DIAMETER; SOL GEL  
**PROCESS;** COMPOSITE FABRICS

**Identifiers:** ELEKTROSPINNEN; Titandioxidnanofaser; Fasereigenschaft

7/8/1176 (Item 33 from file: 95)  
TEME-Technology & Management  
(c) 2010 FIZ TECHNIK. All rights reserved.  
02089792 20060506119

**Synthesis and characterisation on nanotubular titanates and titania**

( Synthese und Charakterisierung von rohrenfoermigem Titanat und Titandioxid im  
**Nanometerbereich** ) , **2006**

**Descriptors:** TITANATE; TITANIUM DIOXIDE; NANOTUBES; SYNTHESIS--  
GENERAL; PH NUMBER; HEAT RESISTANCE; CURVE--GEOMETRY; ANATASE

**Identifiers:** Titanat; Titandioxid; Roehrenform

7/8/1177 (Item 34 from file: 95)  
TEME-Technology & Management  
(c) 2010 FIZ TECHNIK. All rights reserved.  
02084315 20060310741

**Effects of titania different phases on the microstructure and properties of K(ind  
2)Ti(ind 6)O(ind 13) nanowires**  
, **2006**

**Descriptors:** NANO SYSTEM TECHNOLOGY; NANOWIRES; POTASSIUM  
COMPOUNDS; ULTRAVIOLET SPECTRA ; VISIBLE SPECTRA; TITANIUM OXIDES;  
MICROSTRUCTURE; HYDROTHERMAL **PROCESS**

**Identifiers:** HYDROTHERMALE SYNTHESE; Nanotechnologie; Nanodraht

7/8/1178 (Item 35 from file: 95)  
TEME-Technology & Management  
(c) 2010 FIZ TECHNIK. All rights reserved.  
02041796 20060106099

**The anti-microbial activity of titania-nickel ferrite composite nanoparticles**

( Die antimikrobielle Aktivitaet von TiO<sub>2</sub>/NiFe<sub>2</sub>O<sub>4</sub>-Verbundwerkstoff- **Nanoteilchen** ) ,  
**2005**

**Descriptors:** NANOCOMPOSITE MATERIALS; NANOPARTICLES; ANATASE;  
NICKEL FERRITE; MAGNET CORES; ANTIMICROBIAL AGENT; MAGNETISATION;

## Appendix A-5. Irrelevant Titles

TEMPERATURE DEPENDENCE; PHOTOCATALYSIS; ULTRAVIOLET RADIATION;  
NANOSTRUCTURE; **PRODUCTION SEQUENCE**; FLOW CHART

**Identifiers:** KERN SCHALE SYSTEM; ANTIMIKROBIELLE AKTIVITAET;  
Nanopartikel; TiO<sub>2</sub>-Schale; NiFe<sub>2</sub>O<sub>4</sub>-Kern; antimikrobielle Aktivitaet

7/8/1179 (Item 36 from file: 95)

TEME-Technology & Management

(c) 2010 FIZ TECHNIK. All rights reserved.

01975715 20050605666

**Preparation of titanium dioxide nanocrystalline with high photocatalytic activities**  
( Herstellung von Titandioxid-**Nanokristalliten** mit hoher photokatalytischer Aktivitaet ) ,  
**2005**

**Descriptors:** ANATASE; AMORPHOUS PHASE; CRYSTALLISATION;  
HYDROTHERMAL **PROCESS**; NANOCERAMICS; GRAIN GROWTH;  
MICROSTRUCTURE; MORPHOLOGY--GENERAL; PHOTOCATALYSIS;  
METHYLENE BLUE; TEM--TRANSMISSION ELECTRON MICROSCOPY; X RAY  
DIFFRACTION; FOURIER TRANSFORM INFRARED SPECTROSCOPY; BET  
METHOD; FINE GRAIN POWDERS

**Identifiers:** Anatas; Mikrogefuege; Photokatalyse

7/8/1180 (Item 37 from file: 95)

TEME-Technology & Management

(c) 2010 FIZ TECHNIK. All rights reserved.

01901620 20041004681

**Nanocarving of titania (TiO<sub>2</sub>): A novel approach for fabricating chemical sensing platform**  
, **2004**

**Descriptors:** NANOCRYSTALLINE MATERIALS; CHEMICAL SENSORS;  
POLYCRYSTALLINE MATERIALS; CRYSTALLOGRAPHY; SINTERING; SOLAR  
BATTERY; TITANIUM OXIDES; TITANIUM DIOXIDES; ENGRAVINGS;  
ENGRAVING--**PROCESS**

**Identifiers:** NANO GRAVUR TECHNIK; NANOFASER; Nanofaser; Titandioxid; nano-  
Gravur-Technik

7/8/1181 (Item 38 from file: 95)

TEME-Technology & Management

(c) 2010 FIZ TECHNIK. All rights reserved.

01888760 20040803835

**Synthesis of nanotube from a layered H<sub>2</sub>Ti<sub>4</sub>O<sub>9</sub>.H<sub>2</sub>O in a hydrothermal treatment using various titania sources**

( Synthese von **Nanoroehrchen** aus schichtfoermigem H<sub>2</sub>Ti<sub>4</sub>O<sub>9</sub>.H<sub>2</sub>O durch eine hydrothermale Behandlung ausgehend von verschiedenen Titanoxidverbindungen ) , **2004**

**Descriptors:** HYDROTHERMAL **PROCESS**; POWDERS; NANOTUBES;

## Appendix A-5. Irrelevant Titles

MORPHOLOGY; CRYSTALLINITY; REACTION TIME; TEMPERATURE  
DEPENDENCE; PHOTOCATALYSIS; TITANIUM OXIDES; TITANIUM COMPOUNDS  
**Identifiers:** Titanverbindung; Nanoroehrchen; hydrothermale Synthese; Photovoltaik

7/8/1182 (Item 39 from file: 95)  
TEME-Technology & Management  
(c) 2010 FIZ TECHNIK. All rights reserved.  
01858243 20040504981

### **Nanostructured titania (TiO(ind 2)) as hydrogen gas sensor , 2003**

**Descriptors:** CALCINATION; CARBON COMPOUNDS; GAS SENSORS; SOL GEL  
**PROCESS;** TITANIUM COMPOUNDS; TITANIUM DIOXIDES; ANATASE; RUTILE;  
POLY ETHYLENEGLYCOL ; GELLING; AQUEOUS MEDIUM; PORE SIZE;  
HYDROGEN

**Identifiers:** WASSERSTOFFNEUTRALMOLEKUEL; NANOPOROESER WERKSTOFF;  
REAKTIONSTEMPERATUR; 100 GRAD C BEREICH; 4 NANOMETER BEREICH; 600  
GRAD C BEREICH; Calcinieren; Kohlenstoffverbindung

7/8/1183 (Item 40 from file: 95)  
TEME-Technology & Management  
(c) 2010 FIZ TECHNIK. All rights reserved.  
01815331 20030906597

### **Herstellung nanostrukturierter optischer Schichten auf der Basis Titania-Silika mittels einer Kombination der hydrothermalen Synthese und der Sol-Gel Technologie ( Preparation of **nanostructured** optical layers based on **titania** -silica by a combination of hydrothermal synthesis and sol gel technique ) , 2003**

**Descriptors:** ANTI REFLECTION FILMS; COATINGS; INDEX OF REFRACTION;  
HYDROTHERMAL **PROCESS;** NANOCRYSTALLINE MATERIALS; OPTICAL  
APPLICATIONS; LIGHT FILTERS; ORGANIC MATERIAL; PARTICLE SIZE;  
REFLECTING POWER; FILM THICKNESS; SILICON OXIDES; SOL GEL **PROCESS;**  
SUBSTRATES; TITANIUM OXIDES; **PROCESS** PARAMETERS

**Identifiers:** VERBUNDSCHICHT; TiO<sub>2</sub>-SiO<sub>2</sub>-Schicht; hydrothermale Synthese; Sol-Gel-  
Technik

7/8/1184 (Item 41 from file: 95)  
TEME-Technology & Management  
(c) 2010 FIZ TECHNIK. All rights reserved.  
01788088 20030601726

### **Hydrothermal synthesis of nanostructured titania particles and their optical properties ( Hydrothermale Synthese und optische Eigenschaften von **nanokristallinen** Titanoxidpartikeln ) , 2003**

**Descriptors:** ANATASE; FOURIER TRANSFORM INFRARED SPECTROSCOPY;  
HYDROTHERMAL **PROCESS;** CRYSTAL STRUCTURE; NANOCRYSTALLINE  
CERAMICS; OPTICAL PROPERTIES; POWDERS; RUTILE; STRUCTURAL

## Appendix A-5. Irrelevant Titles

STABILITY; PARTICLE SIZE; TITANIUM OXIDES; X RAY PHOTOELECTRON SPECTROSCOPY

**Identifiers:** TiO<sub>2</sub>; optische Eigenschaft; Struktur; hydrothermale Synthese

7/8/1185 (Item 42 from file: 95)

TEME-Technology & Management

(c) 2010 FIZ TECHNIK. All rights reserved.

01765164 20030404441

**Mechanical and tribological properties of an epoxy resin containing titanium dioxide nanoparticles**

( Mechanische und tribologische Eigenschaften von Epoxidharz, das Titandioxid-Nanopartikel enthaelt ) , 2002

**Descriptors:** BENDING STRENGTH; FLEXURAL MODULUS; EPOXIDE RESINS; CERAMICS; MECHANICAL PROPERTIES; MECHANICAL TEST; MECHANICAL REINFORCEMENT; PARTICLE SIZE; SCANNING ELECTRON MICROSCOPY; TITANIUM DIOXIDES; WEAR RESISTANCE

**Identifiers:** Epoxidharz; Titandioxid-Nanopartikel; mechanische Pruefung

7/8/1186 (Item 43 from file: 95)

TEME-Technology & Management

(c) 2010 FIZ TECHNIK. All rights reserved.

01712082 20030105048

**New hydrolytic process for producing zirconium dioxide, and titanium dioxide nanoparticles**

( Ein neuer hydrolytischer Prozess zur Herstellung von Zirkondioxid-, Zinndioxid- und Titandioxid-Nanopartikeln ) , 2002

**Descriptors:** ZIRCONIUM OXIDES; STANNIC OXIDES; TITANIUM OXIDES; NANOCRYSTALLINE CERAMICS ; ETHERIFICATION; X RAY DIFFRACTION; ETHYL ALCOHOL; TEMPERATURE DEPENDENCE; HOMOGENEITY

**Identifiers:** Oxidkeramik; Nanopartikel; hydrolytische Synthese

7/8/1187 (Item 44 from file: 95)

TEME-Technology & Management

(c) 2010 FIZ TECHNIK. All rights reserved.

01659143 20020709361

**Effects of erbium oxalate content and temperature on green up-conversion luminescence of erbium oxalate nanoparticles/titania/ormosil composite thin films , 2002**

**Descriptors:** COMPOSITE MATERIALS; ERBIUM COMPOUNDS; MICROEMULSION; NANOCRYSTALLINE MATERIALS; OPTICAL FILMS; OPTICAL FREQUENCY CONVERSION; PHOTOLUMINESCENCE; SOL GEL PROCESS; LOW TEMPERATURE; THIN FILMS

## Appendix A-5. Irrelevant Titles

**Identifiers:** STRAHLUNGSLEBENSDAUER; MIKROEMULSIONSTECHNIK;  
WAERMEBEHANDLUNGSTEMPERATUR; 500 NANOMETER BEREICH;  
Verbundwerkstoff; Erbiumverbindung

7/8/1188 (Item 45 from file: 95)

TEME-Technology & Management

(c) 2010 FIZ TECHNIK. All rights reserved.

01622920 20020400607

**Photocatalytic characteristics of nanometer-sized titania powders fabricated by a homogeneous-precipitation process**

( Photokatalytische Charakterisierung von Titanoxidpulvern mit Korngrößen im Nanometerbereich, hergestellt mittels eines homogenen Fällungsprozesses ) , 2002

**Descriptors:** TITANIUM OXIDES; POWDERS; CHEMICAL PRECIPITATION; GRAIN SIZE; SUSPENSIONS; LEAD ION; COPPER ION; SPECIFIC AREA; PHOTOCATALYSIS

**Identifiers:** Titanoxidpulver; Fällung; Korngröße

7/8/1189 (Item 46 from file: 95)

TEME-Technology & Management

(c) 2010 FIZ TECHNIK. All rights reserved.

01575163 20020108261

**Power and limits of reactive agents , 2002**

**Descriptors:** LEARNING--ARTIFICIAL INTELLIGENCE; AUTONOMOUS ROBOTS; ARTIFICIAL NEURAL NETWORKS; ROBOTS; COGNITION

**Identifiers:** HANDLUNG; VERHALTEN IM BEDARFSFALL; INTERNE DARSTELLUNG; EVOLUTIONÄRE ROBOTER; Lernen; Mobiler Roboter

7/8/1190 (Item 47 from file: 95)

TEME-Technology & Management

(c) 2010 FIZ TECHNIK. All rights reserved.

01486664 20010203203

**Up-conversion luminescence of erbium(III) oxalate nanoparticles/ titania/ $\gamma$ -glycidoxypropylmethoxysilane composite sol-gel thin films**

( Aufwärtsumwandlungslumineszenz von Sol-Gel-Verbundwerkstoff-Dünnschichten aus Erbium(III)oxalat-Nanopartikeln, Titandioxid und  $\gamma$ -Glycidoxypropyltrimethoxysilan ) , 2001

**Descriptors:** PHOTOLUMINESCENCE; OXALATE; ERBIUM COMPOUNDS; TITANIUM DIOXIDES; ORGANIC COMPOUNDS; SILICON COMPOUNDS; SOL GEL FILMS; NANOCRYSTALLINE MATERIALS; COMPOSITE MATERIALS; MICROEMULSION; SOL GEL PROCESS; PARTICLE SIZE; DURATION OF LIFE; ULTRAVIOLET SPECTROMETRY; HEAT TREATMENT--MATERIALS; ELECTRON TRANSITION; THIN FILMS; GLASS; SILICON; TEM--TRANSMISSION ELECTRON MICROSCOPY; CONSTITUTIONAL DIAGRAM; ENERGY LEVEL; LAMP PUMPING;

## Appendix A-5. Irrelevant Titles

### LIGHT TRANSMISSION

**Identifiers:** ERBIUMOXALAT; Photolumineszenz; Er-Oxalat-TiO<sub>2</sub>-Siloxan-  
Verbundwerkstoff

7/8/1191 (Item 1 from file: 99)

Wilson Appl. Sci & Tech Abs

(c) 2009 The HW Wilson Co. All rights reserved.

3588120 **H.W. Wilson Record Number:** BAST09140456

**Comparative Photoactivity and Antibacterial Properties of C60 Fullerenes and Titanium Dioxide Nanoparticles**

**Descriptors:** Antibacterial agents; Buckminsterfullerene; Titanium dioxide ;  
20090615

7/8/1192 (Item 2 from file: 99)

Wilson Appl. Sci & Tech Abs

(c) 2009 The HW Wilson Co. All rights reserved.

3542859 **H.W. Wilson Record Number:** BAST09125658

**Corrigendum: Effect of process parameters on the chemical vapour synthesis of nanocrystalline titania**

**Descriptors:** Titanium oxide powders--Synthesis; Nanostructured materials ;  
20090407

7/8/1193 (Item 3 from file: 99)

Wilson Appl. Sci & Tech Abs

(c) 2009 The HW Wilson Co. All rights reserved.

3450453 **H.W. Wilson Record Number:** BAST08160915

**Effect of process parameters on the chemical vapour synthesis of nanocrystalline titania**

**Descriptors:** Titanium oxide powders--Synthesis; Nanostructured materials ;  
20080807

7/8/1194 (Item 4 from file: 99)

Wilson Appl. Sci & Tech Abs

(c) 2009 The HW Wilson Co. All rights reserved.

3267554 **H.W. Wilson Record Number:** BAST07142099

**Behavioral and Physiological Changes in Daphnia magna when Exposed to Nanoparticle Suspensions (Titanium Dioxide, Nano-C60, and C60HxC70Hx)**

**Descriptors:** Nanoparticles--Physiological effect; Daphnia ;  
20070615

7/8/1195 (Item 5 from file: 99)

Wilson Appl. Sci & Tech Abs

## Appendix A-5. Irrelevant Titles

(c) 2009 The HW Wilson Co. All rights reserved.

3213305 **H.W. Wilson Record Number:** BAST04147866

**Synthesis of nanotube from a layered H<sub>2</sub>Ti<sub>4</sub>O<sub>9</sub> {Graphic character omitted} H<sub>2</sub>O in a hydrothermal treatment using various titania sources**

**Descriptors:** Titanium oxides--Derivatives; Nanotubes-- Synthesis ;  
20040701

7/8/1196 (Item 6 from file: 99)

Wilson Appl. Sci & Tech Abs

(c) 2009 The HW Wilson Co. All rights reserved.

2854265 **H.W. Wilson Record Number:** BAST05131009

**Preparation of Titania Nanotubes and Their Environmental Applications as Electrode**

**Descriptors:** Photocatalytic oxidation; Industrial waste **disposal**--Electrolytic treatment;

Semiconductor electrodes-- Efficiency; Nanotubes ;

20050515

7/8/1197 (Item 1 from file: 103)

Energy SciTec

(c) 2010 Contains copyrighted material. All rights reserved.

07030189 BRN; RN09129133; TVI 4043

**Title: Thin films of nano structured and nano particulated titanium dioxide produced by sol-gel method; Filmes finos de dióxido de titânio nanoestruturado e nanoparticulado confeccionados pelo método Sol-Gel**

**Publication Date: 20080701**

**Availability Date:** 20091203

**Descriptors:** ANGULAR DISTRIBUTION; BRAZILIAN LNLS; COLLOIDS;  
CRYSTALLOGRAPHY; GELATION; LIGHT SOURCES; MICROSTRUCTURE;  
NANOSTRUCTURES; SMALL ANGLE SCATTERING; SOL-GEL **PROCESS**; SOLIDS;  
STRUCTURAL CHEMICAL ANALYSIS; SYNCHROTRON RADIATION; TITANIUM;  
TITANIUM OXIDES; X RADIATION; X-RAY DIFFRACTION

**Subject Categories:** 75 -- CONDENSED MATTER PHYSICS, SUPERCONDUCTIVITY  
& SUPERFLUIDITY

7/8/1198 (Item 2 from file: 103)

Energy SciTec

(c) 2010 Contains copyrighted material. All rights reserved.

06545912 INIS; RN09039842; TVI 4011

**Title: Nano structured Titania membrane: preparation, characterization and photo catalytic activity; Sakhte membran-e titaniai-ye nanosakhtar va barresi-ye khasiat-e photocatalysti-ye an**

**Publication Date: 20080915**

**Availability Date:** 20090514

## Appendix A-5. Irrelevant Titles

**Descriptors:** CALCINATION; COLLOIDS; CRACKING; DIP COATING; MEMBRANES; METHYL ORANGE; NANOSTRUCTURES; PARTICLE SIZE; PHOTOCATALYSIS; SCANNING ELECTRON MICROSCOPY ; SOL-GEL **PROCESS**; SOLS; TITANIUM OXIDES

**Subject Categories:** 36 -- MATERIALS SCIENCE

7/8/1199 (Item 3 from file: 103)

Energy SciTec

(c) 2010 Contains copyrighted material. All rights reserved.

06368377 INIS; RN08109456; TVI 3931

**Title:** Hydrothermal/microwave and hydrothermal/ultrasonic synthesis of nanocrystalline titania, zirconia, and hafnia; **Gidrotermal'no-mikrovolnovoj i gidrotermal'no-ul'trazvukovoj sintez nanokristallicheskih dioksidov titana, tsirkoniya, gafniya**

**Publication Date:** 20071115

**Availability Date:** 20080915

**Descriptors:** CHEMICAL PREPARATION; COMPARATIVE EVALUATIONS; CRYSTAL LATTICES; CRYSTALLIZATION; HAFNIUM OXIDES; KINETICS; MICROWAVE RADIATION; PARTICLE SIZE; PHASE STUDIES; POWDERS; SPECIFIC SURFACE AREA; STABILITY; TEMPERATURE RANGE 0400-1000 K; ULTRASONIC WAVES; X-RAY DIFFRACTION; ZIRCONIUM OXIDES

**Subject Categories:** 37 -- INORGANIC, ORGANIC, PHYSICAL & ANALYTICAL CHEMISTRY

7/8/1200 (Item 4 from file: 103)

Energy SciTec

(c) 2010 Contains copyrighted material. All rights reserved.

06292563 NLN; RN08093201; TVI 3926

**Title:** Hydroxyl radicals ( $\text{OH}\cdot$ ) are associated with titanium dioxide ( $\text{TiO}_2$ ) nanoparticle-induced cytotoxicity and oxidative DNA damage in fish cells

**Publication Date:** 20080402

**Availability Date:** 20080807

**Descriptors:** DNA; DNA DAMAGES; ELECTRON SPIN RESONANCE; ENDONUCLEASES; GOLDFISH; GUANINE ; HYDROXYL RADICALS; NANOSTRUCTURES; OXIDATION; PYRAZINES; TITANIUM OXIDES; **TOXICITY**

**Subject Categories:** 60 -- APPLIED LIFE SCIENCES

7/8/1201 (Item 5 from file: 103)

Energy SciTec

(c) 2010 Contains copyrighted material. All rights reserved.

06273942 GB; RN08084395; TVI 0803

**Title:** Photocatalytic  $\text{H}_2$  production from methanol aqueous solution over titania nanoparticles with mesostructures

**Publication Date:** 20080115

## Appendix A-5. Irrelevant Titles

**Availability Date:** 20080724

**Descriptors:** TITANIUM OXIDES; **AQUEOUS SOLUTIONS**; HYDROGEN; METHANOL; PHOTOCATALYSIS; FEDERAL REPUBLIC OF GERMANY; CALCINATION; NANOSTRUCTURES; PARTICLES; SPECIFIC SURFACE AREA; HYDROGEN **PRODUCTION**; CATALYSTS; IRRADIATION; REAGENTS

**Subject Categories:** 08 -- HYDROGEN

7/8/1202 (Item 6 from file: 103)

Energy SciTec

(c) 2010 Contains copyrighted material. All rights reserved.

06200156 INIS; RN08037611; TVI 3910

**Title:** Crystallization behavior and micromorphology of sol-gel derived mesoporous nano-particles Titania; Kelakuan kristalisasi dan mikromorpologi nano-partikel Titania mesopori diperoleh dari metode sol-gel

**Publication Date:** 20041015

**Availability Date:** 20080414

**Descriptors:** ADSORPTION; ANNEALING; CRYSTALLIZATION; FRACTALS; MESOSPHERE; MORPHOLOGY; NITROGEN; SOL-GEL **PROCESS**; TITANIUM; TRANSMISSION ELECTRON MICROSCOPY; X-RAY DIFFRACTION

**Subject Categories:** 36 -- MATERIALS SCIENCE

7/8/1203 (Item 7 from file: 103)

Energy SciTec

(c) 2010 Contains copyrighted material. All rights reserved.

06094947 NLN; RN07132986; TVI 3844

**Title:** Optical properties of in situ doped and undoped titania nanocatalysts and doped titania sol-gel nanofilms

**Publication Date:** 20060530

**Availability Date:** 20071227

**Descriptors:** ABSORPTION; ABSORPTION SPECTRA; DOPED MATERIALS; EMISSION SPECTROSCOPY; EV RANGE 01-10; FLUORESCENCE; OPTICAL PROPERTIES; QUENCHING; RUTILE; SOL-GEL **PROCESS**; SPUTTERING; THIN FILMS; TITANIUM OXIDES

**Subject Categories:** 36 -- MATERIALS SCIENCE

7/8/1204 (Item 8 from file: 103)

Energy SciTec

(c) 2010 Contains copyrighted material. All rights reserved.

05980932 GBN; RN07101542; TVI 3834

**Title:** Structural effects of niobium and silver doping on titanium dioxide nanoparticles

**Publication Date:** 20070315

**Availability Date:** 20070927

## Appendix A-5. Irrelevant Titles

**Descriptors:** ANNEALING; CONCENTRATION RATIO; DOPED MATERIALS; NANOSTRUCTURES; NIOBIUM; PARTICLES; PHASE TRANSFORMATIONS; SCANNING ELECTRON MICROSCOPY; SILVER; SOL-GEL **PROCESS**; TEMPERATURE DEPENDENCE; TITANIUM OXIDES; TRANSMISSION ELECTRON MICROSCOPY; X-RAY DIFFRACTION; X-RAY PHOTOELECTRON SPECTROSCOPY; X-RAY SPECTROSCOPY

**Subject Categories:** 75 -- CONDENSED MATTER PHYSICS, SUPERCONDUCTIVITY & SUPERFLUIDITY

7/8/1205 (Item 9 from file: 103)

Energy SciTec

(c) 2010 Contains copyrighted material. All rights reserved.

05434243 LBNL; RN05145360

**Title:** Surfactant-assisted elimination of a high energy facet as a means of controlling the shapes of TiO<sub>2</sub> nanocrystals

**Publication Date:** 20031101

**Availability Date:** 20060109

**Descriptors:** TITANIUM OXIDES; CRYSTAL GROWTH; **PROCESS CONTROL**; SURFACTANTS; NANOSTRUCTURES

**Subject Categories:** 36 -- MATERIALS SCIENCE

7/8/1206 (Item 10 from file: 103)

Energy SciTec

(c) 2010 Contains copyrighted material. All rights reserved.

05308971 INIS; RN05066699; TVI 3624; TRN RU0501261052218

**Title:** Separation and preconcentration of trace heavy metal ions with nanometer-size titanium dioxide (anatase) and determination by fluorination assisted ETV-ICP-AES with slurry sampling; Kонтсентрирование следовых количеств ионов тяжелых металлов с помощью нанометровых частиц диоксида титана (анатаза) с целью последующего их определения методом атомно-эмиссионной спектроскопии с индуктивно связанной плазмой с электротермическим испарением проб

**Publication Date:** 20031101

**Availability Date:** 20050703

**Descriptors:** ACCURACY; ADSORPTION; CADMIUM COMPOUNDS; DISTRIBUTION FUNCTIONS; EMISSION SPECTROSCOPY; PH VALUE; QUANTITATIVE CHEMICAL ANALYSIS; SAMPLE PREPARATION; SENSITIVITY; SEPARATION **PROCESSES**; TITANIUM OXIDES; TRACE AMOUNTS; WATER

**Subject Categories:** 37 -- INORGANIC, ORGANIC, PHYSICAL & ANALYTICAL CHEMISTRY

7/8/1207 (Item 11 from file: 103)

Energy SciTec

(c) 2010 Contains copyrighted material. All rights reserved.

05055301 INIS

## Appendix A-5. Irrelevant Titles

**Title:** Structural transformation of nanocrystalline titania by sol-gel and the growth kinetics of crystallites

**Publication Date:** 20020501

**Availability Date:** 20040412

**Descriptors:** ACTIVATION ENERGY; CRYSTAL GROWTH; CRYSTAL STRUCTURE; CRYSTAL-PHASE TRANSFORMATIONS; CRYSTALLIZATION; GRAIN SIZE; NANOSTRUCTURES; RUTILE; SOL-GEL **PROCESS**; TEMPERATURE DEPENDENCE; TITANIUM OXIDES; X-RAY DIFFRACTION

**Subject Categories:** 75 -- CONDENSED MATTER PHYSICS, SUPERCONDUCTIVITY & SUPERFLUIDITY

7/8/1208 (Item 12 from file: 103)

Energy SciTec

(c) 2010 Contains copyrighted material. All rights reserved.

04888950 MXN

**Title:** Study of high resolution Tem images of nano crystals of cobalt titanate obtained from cobalt doped titania gels

**Publication Date:** 20020701

**Availability Date:** 20030120

**Descriptors:** COBALT; COMPOSITE MATERIALS; CRYSTAL STRUCTURE; DOPED MATERIALS; GELS; HEAT TREATMENTS; SOL-GEL **PROCESS**; SYNTHESIS; THERMOLUMINESCENCE; TIME DEPENDENCE; TITANATES; TRANSMISSION ELECTRON MICROSCOPY; X-RAY DIFFRACTION

**Subject Categories:** 36 -- MATERIALS SCIENCE

7/8/1210 (Item 2 from file: 149)

TGG Health&Wellness DB(SM)

(c) 2010 Gale/Cengage. All rights reserved.

04612397 **Supplier Number:** 214335429

**Nanosized titanium dioxide enhanced inflammatory responses in the septic brain of mouse.(Report)**

2010

**Descriptors:** Titanium dioxide--Analysis; Surface active agents--Analysis; Brain-- Analysis; Enzyme-linked immunosorbent assay--Analysis; Nitric oxide-- Analysis; Mitogens-- Analysis; Neurosciences--Analysis; Sulfates--Analysis

**SIC Codes:** 2841 Soap and other detergents; 2843 Surface active agents; 2816 Inorganic pigments; 2813 Industrial gases; 2819 Industrial inorganic chemicals, not elsewhere classified

**Product/Industry Names:** 2843000 (Surface Active Agents); 2816000 (Inorganic Pigments & Fillers) ; 2813772 (Nitric Oxide)

**NAICS Codes:** 325613 Surface Active Agent **Manufacturing**; 325131 Inorganic Dye and Pigment **Manufacturing**; 32512 Industrial Gas **Manufacturing**

7/8/1211 (Item 3 from file: 149)

## Appendix A-5. Irrelevant Titles

TGG Health&Wellness DB(SM)

(c) 2010 Gale/Cengage. All rights reserved.

04523850 **Supplier Number:** 210442871

**Determination of trace amounts of total dissolved cationic aluminium species in environmental samples by solid phase extraction using nanometer-sized titanium dioxide and atomic spectrometry techniques.(Report)**

2009

**Descriptors:** Titanium dioxide--Usage; Titanium dioxide--**Analysis**; Titanium dioxide--Methods; Pyrolysis--**Analysis**; Pyrolysis--Methods; Anabolic steroids--Usage; Anabolic steroids--**Analysis**; Anabolic steroids-- Methods; Adsorption--**Analysis**; Adsorption--Methods; Spectrum **analysis**--**Analysis**; Spectrum **analysis**--Methods; Universities and colleges--**Analysis**; Universities and colleges-- Methods; Hydrochloric acid--**Analysis**; Hydrochloric acid--Methods

**SIC Codes:** 2834 Pharmaceutical preparations; 2816 Inorganic pigments; 8221 Colleges and universities; 2819 Industrial inorganic chemicals, not elsewhere classified

**Product/Industry Names:** 2834137 (Anabolic Agents); 2816000 (Inorganic Pigments & Fillers); 8220000 (Colleges & Universities); 2819441 (Hydrochloric Acid)

**NAICS Codes:** 325412 Pharmaceutical Preparation **Manufacturing**; 325131 Inorganic Dye and Pigment **Manufacturing**; 61131 Colleges, Universities, and Professional Schools; 325188 All Other Basic Inorganic Chemical **Manufacturing**

7/8/1212 (Item 4 from file: 149)

TGG Health&Wellness DB(SM)

(c) 2010 Gale/Cengage. All rights reserved.

04497507 **Supplier Number:** 209395969

**Preparation and antibacterial properties of plasma sprayed nano- titania/silver coatings.(Report)**

2009

**Descriptors:** Escherichia coli--**Analysis**; **Water** quality--**Analysis**; Silver--**Analysis**; Coatings--**Analysis**; Antibacterial agents-- **Analysis**; Coatings industry--**Analysis**

**SIC Codes:** 2834 Pharmaceutical preparations; 2851 Paints and allied products

**Product/Industry Names:** 3339550 (Silver); 2850000 (Paints & Allied Products); 2852330 (Wire & Insulating Coatings); 2834880 (Bacteriostats)

**NAICS Codes:** 331419 Primary Smelting and Refining of Nonferrous Metal (except Copper and Aluminum); 32551 Paint and Coating **Manufacturing**; 325412 Pharmaceutical Preparation **Manufacturing**

7/8/1213 (Item 5 from file: 149)

TGG Health&Wellness DB(SM)

(c) 2010 Gale/Cengage. All rights reserved.

04433667 **Supplier Number:** 207288113

**Preparation and characterization of nano silver-doped mesoporous titania photocatalysts for dye degradation.(Report)**

2009

**Descriptors:** Azo compounds--Chemical properties; Dextrose--Chemical properties; Glucose

## Appendix A-5. Irrelevant Titles

--Chemical properties; Titanium dioxide--Chemical properties; Urea-- Chemical properties

**SIC Codes:** 2873 Nitrogenous fertilizers

**Product/Industry Names:** 2873200 (Urea)

**NAICS Codes:** 325311 Nitrogenous Fertilizer **Manufacturing**

7/8/1214 (Item 6 from file: 149)

TGG Health&Wellness DB(SM)

(c) 2010 Gale/Cengage. All rights reserved.

04424167 **Supplier Number:** 206962389 (USE FORMAT 7 OR 9 FOR FULL TEXT )

**Nanostructural Evolution of Titania-Based Materials Using Modified Titanium**

**Precursors.(Report)**

2009

**Descriptors:** Condensation--Analysis; Hydrolysis--Analysis; Nuclear magnetic resonance spectroscopy--Analysis; Aminosalicylic acids--Analysis; Titanium--Analysis; Atmospheric nucleation--Analysis

7/8/1215 (Item 7 from file: 149)

TGG Health&Wellness DB(SM)

(c) 2010 Gale/Cengage. All rights reserved.

04338965 **Supplier Number:** 204016011

**Titanium dioxide nanoparticles induce apoptosis through the JNK/p38-caspase-8-Bid pathway in phytohemagglutinin-stimulated human lymphocytes.(Report)**

2009

**Descriptors:** Protein kinases--Analysis; Apoptosis--Analysis; Lymphocytes-- Analysis; Titanium dioxide--Analysis; Public health-- Analysis; RNA--Analysis; Nanoparticles-- Analysis

**SIC Codes:** 2816 Inorganic pigments

**Product/Industry Names:** 8000120 (Public Health Care); 9005200 (Health Programs-Total Govt); 9105200 (Health Programs); 2816000 (Inorganic Pigments & Fillers)

**NAICS Codes:** 62 Health Care and Social Assistance; 923 Administration of **Human** Resource Programs; 92312 Administration of Public **Health** Programs; 325131 Inorganic Dye and Pigment **Manufacturing**

7/8/1216 (Item 8 from file: 149)

TGG Health&Wellness DB(SM)

(c) 2010 Gale/Cengage. All rights reserved.

04320364 **Supplier Number:** 203418108

**Specific effects of single antioxidants in the lipid peroxidation caused by nano-titania used in sunscreen lotions.(Report)**

2009

**Descriptors:** Powders--Analysis; Essential fatty acids--Analysis; Lipid peroxidation-- Analysis; Sunscreens (Cosmetics)--Analysis; Phenylalanine--Analysis; Phosphates-- Analysis; Toiletries industry--Analysis; Unsaturated fatty acids--Analysis; Organic compounds--Analysis

## Appendix A-5. Irrelevant Titles

**SIC Codes:** 2844 Toilet preparations; 2899 Chemical preparations, not elsewhere classified

**Product/Industry Names:** 2844515 (Suntan & Sunscreen Lotions); 2899260 (Unsaturated Fatty Acids) ; 2860000 (Organic Chemicals)

**NAICS Codes:** 32562 Toilet Preparation **Manufacturing**; 325998 All Other Miscellaneous Chemical Product and Preparation **Manufacturing**; 3251 Basic Chemical **Manufacturing**

7/8/1217 (Item 9 from file: 149)

TGG Health&Wellness DB(SM)

(c) 2010 Gale/Cengage. All rights reserved.

04295051 **Supplier Number:** 202611298

**A nitric oxide biosensor based on the photovoltaic effect of nano titanium dioxide on hemoglobin.(Author abstract)(Report)**

2009

**Descriptors:** Biosensors--Materials; Nitric oxide--Usage; Nitric oxide--Chemical properties; Titanium dioxide--Chemical properties; Hemoglobin--Chemical properties

**Geographic Codes/Names:** 9CHIN China

**SIC Codes:** 2813 Industrial gases

**Product/Industry Names:** 2813772 (Nitric Oxide)

**NAICS Codes:** 32512 Industrial Gas **Manufacturing**

7/8/1218 (Item 10 from file: 149)

TGG Health&Wellness DB(SM)

(c) 2010 Gale/Cengage. All rights reserved.

04227680 **Supplier Number:** 200421209

**Nanowire-structured titanate with anatase titania: Characterization and photocatalytic activity.(Report)**

2009

**Descriptors:** Acetic acid--Optical properties; Organic acids--Optical properties; Nanotechnology--Optical properties; Universities and colleges--Optical properties; Alkalies--Optical properties; Sulfates--Optical properties; Crystals--Structure; Crystals--Optical properties

**SIC Codes:** 2819 Industrial inorganic chemicals, not elsewhere classified; 2869 Industrial organic chemicals, not elsewhere classified; 8221 Colleges and universities

**Product/Industry Names:** 2819870 (Precious Metal Compounds); 2868402 (Acetic Acid); 8220000 (Colleges & Universities)

**NAICS Codes:** 325188 All Other Basic Inorganic Chemical **Manufacturing**; 325199 All Other Basic Organic Chemical **Manufacturing**; 61131 Colleges, Universities, and Professional Schools

7/8/1220 (Item 12 from file: 149)

TGG Health&Wellness DB(SM)

(c) 2010 Gale/Cengage. All rights reserved.

## Appendix A-5. Irrelevant Titles

04226390 **Supplier Number:** 200399875

**Induction of chronic inflammation in mice treated with titanium dioxide nanoparticles by intratracheal instillation.(Report)**

2009

**Descriptors:** Inflammation--Analysis; Titanium dioxide--Analysis; Antigens--Analysis; Immunoglobulin E--Analysis; Nanotechnology--Analysis; Nanoparticles-- Analysis

**SIC Codes:** 2816 Inorganic pigments

**Product/Industry Names:** 2816000 (Inorganic Pigments & Fillers)

**NAICS Codes:** 325131 Inorganic Dye and Pigment **Manufacturing**

7/8/1221 (Item 13 from file: 149)

TGG Health&Wellness DB(SM)

(c) 2010 Gale/Cengage. All rights reserved.

04113406 **Supplier Number:** 196391333 (USE FORMAT 7 OR 9 FOR FULL TEXT )

**Magnetoswitchable controlled photocatalytic system using ferromagnetic Fe<sub>3</sub>O<sub>4</sub>-doped titania nanorods photocatalysts with enhanced photoactivity.(Report)**

2009

**Descriptors:** Formaldehyde; Ferromagnetism; Organic acids

**SIC Codes:** 2869 Industrial organic chemicals, not elsewhere classified

**Product/Industry Names:** 2868520 (Formaldehyde)

**NAICS Codes:** 325199 All Other Basic Organic Chemical **Manufacturing**

7/8/1222 (Item 14 from file: 149)

TGG Health&Wellness DB(SM)

(c) 2010 Gale/Cengage. All rights reserved.

03954435 **Supplier Number:** 190961978 (USE FORMAT 7 OR 9 FOR FULL TEXT )

**Nano-titania assisted photoreduction of Cr(VI).**

2008

**Descriptors:** Organic acids--Analysis; Thermodynamics--Analysis; Formic acid--Analysis; Health maintenance organizations--Analysis; Electrochemistry--Analysis; Rutile--Analysis; Electrochemical reactions--Analysis; Sulfites--Analysis

**SIC Codes:** 2834 Pharmaceutical preparations; 2869 Industrial organic chemicals, not elsewhere classified; 6324 Hospital and medical service plans

**Product/Industry Names:** 2834981 (Veterinary Antibiotics); 2868406 (Formic Acid); 8000130 (Health Maintenance Organizations)

**NAICS Codes:** 325412 Pharmaceutical Preparation **Manufacturing**; 325199 All Other Basic Organic Chemical **Manufacturing**; 621491 HMO Medical Centers

7/8/1223 (Item 15 from file: 149)

TGG Health&Wellness DB(SM)

(c) 2010 Gale/Cengage. All rights reserved.

03952415 **Supplier Number:** 190950993 (USE FORMAT 7 OR 9 FOR FULL TEXT )

**An in situ approach to prepare nanorods of titania -hydroxyapatite (TiO<sub>2</sub>-HAp) nanocomposite by microwave hydrothermal technique.(Report)**

## Appendix A-5. Irrelevant Titles

2008

**Descriptors:** Nanotechnology--Mechanical properties; Nanotechnology--Methods; Hydroxylapatite--Mechanical properties; Hydroxylapatite--Methods; Implant dentures--Mechanical properties; Implant dentures--Methods

7/8/1224 (Item 16 from file: 149)

TGG Health&Wellness DB(SM)

(c) 2010 Gale/Cengage. All rights reserved.

03890459 **Supplier Number:** 188287301 (USE FORMAT 7 OR 9 FOR FULL TEXT )

**Platinum nanoparticles supported on titania as an efficient hydrogen-transfer catalyst.(Report)**

2008

**Descriptors:** Hydrogenation; Nanotechnology; Oxidoreductases; Nanoparticles

**SIC Codes:** 2812 Alkalies and chlorine

**Product/Industry Names:** 2812420 (Potassium Hydroxide)

**NAICS Codes:** 325181 Alkalies and Chlorine **Manufacturing**

7/8/1225 (Item 17 from file: 149)

TGG Health&Wellness DB(SM)

(c) 2010 Gale/Cengage. All rights reserved.

03884488 **Supplier Number:** 188071276 (USE FORMAT 7 OR 9 FOR FULL TEXT )

**Preparation and antibacterial effect of silver-hydroxyapatite/ titania nanocomposite thin film on titanium.(Report)**

2008

**Descriptors:** Nanotechnology--Analysis; Titanium--Analysis; Antibacterial agents--Analysis; Hydroxylapatite--Analysis

**SIC Codes:** 2834 Pharmaceutical preparations

**Product/Industry Names:** 2834880 (Bacteriostats)

**NAICS Codes:** 325412 Pharmaceutical Preparation **Manufacturing**

7/8/1226 (Item 18 from file: 149)

TGG Health&Wellness DB(SM)

(c) 2010 Gale/Cengage. All rights reserved.

03883398 **Supplier Number:** 188006698 (USE FORMAT 7 OR 9 FOR FULL TEXT )

**Effect of Hydroxyapatite and Titania Nanostructures on Early In Vivo Bone Response.(Report)**

2008

**Descriptors:** Implants, Artificial--Analysis; Prosthesis--Analysis; Nanotechnology--Analysis; Biological products--Analysis; Hydroxylapatite--Analysis

**SIC Codes:** 2830 Drugs

**Product/Industry Names:** 2831000 (Biological Products)

**NAICS Codes:** 325414 Biological Product (except Diagnostic) **Manufacturing**

## Appendix A-5. Irrelevant Titles

7/8/1227 (Item 19 from file: 149)

TGG Health&Wellness DB(SM)

(c) 2010 Gale/Cengage. All rights reserved.

03874351 **Supplier Number:** 187631169 (USE FORMAT 7 OR 9 FOR FULL TEXT )

**Direct electrochemistry of hemoglobin on carbonized titania nanotubes and its application in a sensitive reagentless hydrogen peroxide biosensor.(Report)**

2008

**Descriptors:** Electrochemical reactions; Nanotubes; Hydrogen peroxide; Nanotechnology; Glycosylated hemoglobin; Detectors; Electrochemistry

**SIC Codes:** 2819 Industrial inorganic chemicals, not elsewhere classified; 2892 Explosives

**Product/Industry Names:** 2819939 (Hydrogen Peroxide); 2866934 (Trinitrotoluene)

**NAICS Codes:** 325188 All Other Basic Inorganic Chemical **Manufacturing**; 325192 Cyclic Crude and Intermediate **Manufacturing**

7/8/1228 (Item 20 from file: 149)

TGG Health&Wellness DB(SM)

(c) 2010 Gale/Cengage. All rights reserved.

03830066 **Supplier Number:** 185393669 (USE FORMAT 7 OR 9 FOR FULL TEXT )

**Hydroxyapatite/titania nanocomposites derived by combining high-energy ball milling with spark plasma sintering processes .(Report)**

2008

**Descriptors:** Biomedical engineering; Nanotechnology; Hydroxylapatite; Sintering

7/8/1231 (Item 23 from file: 149)

TGG Health&Wellness DB(SM)

(c) 2010 Gale/Cengage. All rights reserved.

03638016 **Supplier Number:** 177859797

**Photocatalytic inactivation effect of gold-doped Ti(O.sub.2) (Au/Ti(O.sub.2)) nanocomposites on human colon carcinoma LoVo cells.(Research Article)(titanium dioxide, gold)(Report)**

2007

**Descriptors:** Catalysis--Research; Photochemical research--Reports; Nanotechnology--Research; Composite materials--Research; Gold compounds--Chemical properties; Titanium dioxide--Chemical properties; Cancer cells--Research; Colon cancer--Research

**Geographic Codes/Names:** 9CHIN China

**SIC Codes:** 2819 Industrial inorganic chemicals, not elsewhere classified

**Event Codes/Names:** 310 Science & research

**Product/Industry Names:** 2819875 (Gold Compounds)

**NAICS Codes:** 325188 All Other Basic Inorganic Chemical **Manufacturing**

7/8/1232 (Item 24 from file: 149)

TGG Health&Wellness DB(SM)

(c) 2010 Gale/Cengage. All rights reserved.

03309164 **Supplier Number:** 165680921 (USE FORMAT 7 OR 9 FOR FULL TEXT )

## Appendix A-5. Irrelevant Titles

**Titanium dioxide (TiO<sub>2</sub>) nanoparticles filled poly(d,l lactid acid) (PDLLA) matrix composites for bone tissue engineering.(Author abstract)**

2007

**Descriptors:** Nanotechnology; Titanium dioxide; Composite materials industry; Nanoparticles; Bones

**SIC Codes:** 2490 Miscellaneous Wood Products; 3080 Miscellaneous Plastics Products, NEC; 3399 Primary metal products, not elsewhere classified

7/8/1233 (Item 25 from file: 149)

TGG Health&Wellness DB(SM)

(c) 2010 Gale/Cengage. All rights reserved.

03276904 **Supplier Number:** 164116971 (USE FORMAT 7 OR 9 FOR FULL TEXT )

**Sonocatalytic degradation of methyl parathion in the presence of micron-sized and nano-sized rutile titanium dioxide catalysts and comparison of their sonocatalytic abilities.(Author abstract)**

2007

**Descriptors:** Catalysts--Comparative **analysis**; Titanium dioxide--Comparative **analysis**; Cholinesterase inhibitors--Comparative **analysis**; Indicators and test-papers--Comparative **analysis**

**SIC Codes:** 2899 Chemical preparations, not elsewhere classified

**Product/Industry Names:** 2899940 (Catalysts)

**NAICS Codes:** 325998 All Other Miscellaneous Chemical Product and Preparation **Manufacturing**

7/8/1234 (Item 26 from file: 149)

TGG Health&Wellness DB(SM)

(c) 2010 Gale/Cengage. All rights reserved.

03251164 **Supplier Number:** 163068318 (USE FORMAT 7 OR 9 FOR FULL TEXT )

**Photocatalytic reduction of 4-nitrophenol with arginine-modified titanium dioxide nanoparticles.(Author abstract)**

2007

**Descriptors:** Nanotechnology; Arginine; Titanium dioxide; Nanoparticles

7/8/1235 (Item 27 from file: 149)

TGG Health&Wellness DB(SM)

(c) 2010 Gale/Cengage. All rights reserved.

03228435 **Supplier Number:** 162472664 (USE FORMAT 7 OR 9 FOR FULL TEXT )

**A nanostructured titania bioceramic implantable device capable of drug delivery to the temporal lobe of the brain.(Author abstract)**

2007

**Descriptors:** Drugs--Vehicles; Implants, Artificial; Prosthesis; Nanotechnology; LSD (Drug); Drug delivery systems

## Appendix A-5. Irrelevant Titles

**SIC Codes:** 2834 Pharmaceutical preparations  
**Product/Industry Names:** 2834030 (Drug Delivery Systems)  
**NAICS Codes:** 325412 Pharmaceutical Preparation **Manufacturing**

7/8/1236 (Item 28 from file: 149)  
TGG Health&Wellness DB(SM)  
(c) 2010 Gale/Cengage. All rights reserved.  
03221118 **Supplier Number:** 162117773 (USE FORMAT 7 OR 9 FOR FULL TEXT )  
**Nanostructured titania/hydroxyapatite composite coatings deposited by high velocity oxy-fuel (HVOF) spraying.(Author abstract)**  
2007  
**Descriptors:** Biomedical engineering; Nanotechnology; Coatings; Coatings industry  
**SIC Codes:** 2851 Paints and allied products  
**Product/Industry Names:** 2850000 (Paints & Allied Products); 2852330 (Wire & Insulating Coatings)  
**NAICS Codes:** 32551 Paint and Coating **Manufacturing**

7/8/1238 (Item 30 from file: 149)  
TGG Health&Wellness DB(SM)  
(c) 2010 Gale/Cengage. All rights reserved.  
03200855 **Supplier Number:** 161271644 (USE FORMAT 7 OR 9 FOR FULL TEXT )  
**Electrochemical sensing DNA damage with nano-titanium dioxide and repair with a medicinal herb species resveratrol.(Author abstract)**  
2007  
**Descriptors:** Medicine, Botanic; Medicine, Herbal; DNA  
**SIC Codes:** 2830 Drugs  
**Product/Industry Names:** 2831812 (Deoxyribonucleic Acid)  
**NAICS Codes:** 325414 Biological Product (except Diagnostic) **Manufacturing**

7/8/1239 (Item 1 from file: 185)  
Zoological Record Online(R)  
(c) 2010 The Thomson Corp. All rights reserved.  
09029966 BIOSIS No. 14501001230  
**Effects of ingested nano-sized titanium dioxide on terrestrial isopods (Porcellio scaber).**  
**Descriptors:**  
Porcellio scaber--Weight, Weight change, Pollutants, Nano-sized titanium dioxide ingestion, Enzymes, Antioxidant enzymes activity, Ingestion, Diet, Energy intake, Food assimilation efficiency, Feeding rate, Digestive gland, Survival, **Environmental** indicators, **Environmental** biomarkers evaluation, Chemical pollution, Chemical factors  
**Broader Terms:**  
Biometrics; Biochemistry; Proteins; Nutrition; Digestion; Energy budget; Digestive system; Ecology; **Population** dynamics; Pollution; Abiotic factors  
**Super Taxa:**  
Animalia

## Appendix A-5. Irrelevant Titles

\*Arthropoda  
\*\*Crustacea  
\*\*\*Malacostraca  
\*\*\*\*Eumalacostraca  
\*\*\*\*\*Peracarida  
\*\*\*\*\*Isopoda

### **Taxa Notes:**

**Notes:** Arthropods; Crustaceans; Invertebrates

### **Systematics:**

Porcellio scaber--( Isopoda ) **Publication Year: 2008**

7/8/1240 (Item 1 from file: 245)

WATERNET(TM)

(c) 2010 American Water Works Association. All rights reserved.

063010

**Adsorption Behavior of Arsenic on Highly Ordered Mesoporous Solids with Nano-Scaled Titania Reactive Sites**

**2006**

**Descriptors:** Adsorption |pH |Arsenic |Ion Exchange |Groundwater |Reverse Osmosis |Water Treatment

7/8/1241 (Item 1 from file: 293)

Engineered Materials Abstracts

(c) 2009 CSA. All rights reserved.

0000624771 IP Accession No: 200911-G1-C-0083092

**Potassium deposition on titania nanotubes boosts action of solar water-splitting cells**

**Publication Date: 2009**

**Descriptors:** Titanium dioxide; Nanotubes; Standards; Deposition; Potassium; Arrays; Ceramics; Residues

**Subj Catg:** G1, General and Nonclassified

7/8/1243 (Item 3 from file: 293)

Engineered Materials Abstracts

(c) 2009 CSA. All rights reserved.

0000469222 IP Accession No: 200802-G1-C-004764

**EFFECT OF SOLUBLE SULPHATE CONCENTRATION ON THE RHEOLOGICAL BEHAVIOUR OF NANOPARTICULATE TITANIA SUSPENSIONS**

**Publication Date: 2007**

**Descriptors:** Titanium dioxide; Nanostructure; Sulfates; Rheological properties; Nanocomposites; Nanomaterials; Agglomeration; Microstructure; Distilled water; Agglomerates; pH; Sulfuric acid; Yield point

**Subj Catg:** G1, General and Nonclassified

## Appendix A-5. Irrelevant Titles

7/8/1244 (Item 4 from file: 293)

Engineered Materials Abstracts

(c) 2009 CSA. All rights reserved.

0000439677 IP Accession No: 200709-D1-P-128806

### **SURFACE MODIFICATION AND POLYMER GRAFTING ?FROM? AND ?THROUGH? TITANIA NANOPARTICLES**

**Publication Date: 2007**

**Descriptors:** Titanium dioxide; Grafting; Nanostructure; Nanoparticles; Surface chemistry ; Adsorption; Polymerization; Agglomeration; Nanomaterials; Catalysts; Silicon dioxide; Initiators; Nanocomposites; Covalent bonds; Gems; Absorbance; Solar cells; Condensation polymerization; Heat stabilizers; Halides; Thermal stability; Luminescence; Enamels; Compact disks; Quantum dots; Photovoltaic cells; Cadmium sulfides; Refractivity; Refractive index; Silicates

**Subj Catg:** D1, Raw Materials

7/8/1245 (Item 5 from file: 293)

Engineered Materials Abstracts

(c) 2009 CSA. All rights reserved.

0000371890 IP Accession No: 200702-G1-C-022468

### **SYNTHESIS AND CHARACTERISATION OF NANO-COMPOSITE ALUMINA-TITANIA CERAMIC MEMBRANE FOR GAS SEPARATION ALUMINA-TITANIA CERAMIC MEMBRANE FOR GAS SEPARATION**

**Publication Date: 2006**

**Descriptors:** Membranes; Titanium dioxide; Polyvinyl alcohols; Porosity; Density; Nanostructure; Ceramics; Permeability; Sintering (powder metallurgy); Viscosity; Ceramic coatings; Pore size; Cracks; Binders; Sol gel **process**; Nanomaterials; Gas separation; Platforms; Aluminum oxide; Surface area; Nanocomposites

**Subj Catg:** G1, General and Nonclassified

7/8/1246 (Item 6 from file: 293)

Engineered Materials Abstracts

(c) 2009 CSA. All rights reserved.

0000370670 IP Accession No: 200702-G1-C-022434

### **SURFACE MODIFICATION OF TITANIA NANOPARTICLES USING ULTRATHIN CERAMIC FILMS CERAMIC FILMS**

**Publication Date: 2006**

**Descriptors:** Titanium dioxide; Deposition; Coating; Aluminum oxide; Nanoparticles; X-ray photoelectron spectroscopy; Vibration; Low pressure; Surface reactions; Ceramics; Surface area; Transmission electron microscopy; Reactors; Infrared radiation; Lithium; Spectroscopy; Sintering

**Subj Catg:** G1, General and Nonclassified

7/8/1247 (Item 7 from file: 293)

## Appendix A-5. Irrelevant Titles

Engineered Materials Abstracts

(c) 2009 CSA. All rights reserved.

0000338710 IP Accession No: 200612-C4-C-30716; 200612-C4-D-30716; 200612-C4-P-30716

**Preparation of Nanometer Titanium Dioxide Powders by Hydrothermal Method and their Isoelectric Points**

**Publication Date: 2005**

**Descriptors:** pH; Titanium dioxide; Transmission electron microscopy; X ray diffraction; Hydrothermal reactions; Anatase; Photographs; Zeta potential; Crystal structure; Chemical engineering; Adjustment; Absorbance

**Subj Catg:** C4, Chemical and Electrochemical Properties; C4, Chemical and Electrochemical Properties; C4, Chemical and Electrochemical Properties

7/8/1248 (Item 8 from file: 293)

Engineered Materials Abstracts

(c) 2009 CSA. All rights reserved.

0000338285 IP Accession No: 200612-C2-C-30464

**Application of Nanometer-Size Titanium Dioxide in Extreme-Trace V(V) Analysis**

**Publication Date: 2006**

**Descriptors:** Titanium dioxide; Nanomaterials; Adsorption; Atomic absorption analysis; pH

**Subj Catg:** C2, Physical Properties

7/8/1249 (Item 9 from file: 293)

Engineered Materials Abstracts

(c) 2009 CSA. All rights reserved.

0000328017 IP Accession No: 200611-F1-C-27125; 200611-F1-D-27125; 200611-F1-P-27125

**Development of low temperature synthesizing nano-sized titania film.**

**Publication Date: 2006**

**Descriptors:** Titanium dioxide; Nanostructure; Thin films; Synthesis; Surface area; Crystal structure; Dyes; Gas sensors; Nanocomposites; Photovoltaic cells; Solar cells; Materials engineering; Photocatalysis; Crystals; Nanomaterials

**Subj Catg:** F1, Engineering Components and Structures; F1, Engineering Components and Structures; F1, Engineering Components and Structures

7/8/1250 (Item 10 from file: 293)

Engineered Materials Abstracts

(c) 2009 CSA. All rights reserved.

0000322241 IP Accession No: 200608-E7-C-18987

**Titania Nanosheet-precipitated Coatings by Hot Water Treatment under Electric Field**

**Publication Date: 2005**

**Descriptors:** Titanium dioxide; Nanostructure; Electric fields; Hot water; Sol gel process;

## Appendix A-5. Irrelevant Titles

Oxide coatings; Nanomaterials  
**Subj Catg:** E7, Surface Finishing

7/8/1251 (Item 11 from file: 293)  
Engineered Materials Abstracts  
(c) 2009 CSA. All rights reserved.  
0000318995 IP Accession No: 200607-E2-D-16268  
**PREPARATION OF PA6/NANO TITANIUM DIOXIDE COMPOSITE AND ITS SPINNABILITY**  
**Publication Date: 2004**  
**Descriptors:** Nanocomposites; Titanium dioxide; Nylon 6; Polyamide resins; Nanostructure; Fiber technology; Spinning (materials)  
**Subj Catg:** E2, Working and Forming

7/8/1252 (Item 12 from file: 293)  
Engineered Materials Abstracts  
(c) 2009 CSA. All rights reserved.  
0000314462 IP Accession No: 200605-D1-C-09799  
**Preparation of Nano-Structured Titania Porous Films by Polyethylene Glycol Templating**  
**Publication Date: 2004**  
**Descriptors:** Titanium dioxide; Nanostructure; Porosity; Oxide films; Nanomaterials; Polyethylene glycol; Glass; Surface area; Dip coatings; Molecular weight; Sol gel **process**; Precursors; Surface chemistry; Morphology; Pore size  
**Subj Catg:** D1, Raw Materials

7/8/1253 (Item 13 from file: 293)  
Engineered Materials Abstracts  
(c) 2009 CSA. All rights reserved.  
0000313664 IP Accession No: 200605-C2-C-08832  
**M Low-Temperature Photocleaning of Sulfur-Poisoned Au Nanoparticles on Titanium Dioxide Film**  
**Publication Date: 2006**  
**Descriptors:** Sulfur; Surface chemistry; Desorption; Chemisorption; X-rays; Anatase; Reaction kinetics; Adsorption; Titanium dioxide; Sol gel **process**; Spectra; Nanoparticles; Rate constants; Photoelectrons; Deposition  
**Subj Catg:** C2, Physical Properties

7/8/1254 (Item 14 from file: 293)  
Engineered Materials Abstracts  
(c) 2009 CSA. All rights reserved.  
0000306578 IP Accession No: 200602-D1-C-03266

## Appendix A-5. Irrelevant Titles

### **FABRICATION OF ELECTROSPUN TITANIA NANOFIBRE**

**Publication Date:** 2005

**Descriptors:** Titanium dioxide; Nanomaterials; Electrospinning; Electric fields; Anatase; Ceramic fibers; **Process** parameters; Precursors

**Subj Catg:** D1, Raw Materials

7/8/1257 (Item 17 from file: 293)

Engineered Materials Abstracts

(c) 2009 CSA. All rights reserved.

0000294209 IP Accession No: 200510-E7-C-18317

**Surface - modification of nanosized titanium dioxide particles**

**Publication Date:** 2004

**Descriptors:** Titanium dioxide; Nanomaterials; Surface treatment; Dispersing

**Subj Catg:** E7, Surface Finishing

7/8/1258 (Item 18 from file: 293)

Engineered Materials Abstracts

(c) 2009 CSA. All rights reserved.

0000291226 IP Accession No: 200509-A1-C-14863

**Effect of brookite phase on titania nanocrystal phase transition.**

**Publication Date:** 2005

**Descriptors:** Phase transformations; Titanium dioxide; Nanostructure; Anatase; X ray diffraction; Precursors; Lattice parameters; Sol-gel **processes**

**Subj Catg:** A1, Constitution and Structural Hardening

7/8/1259 (Item 19 from file: 293)

Engineered Materials Abstracts

(c) 2009 CSA. All rights reserved.

0000282236 IP Accession No: 200409-A2-C-0968

**Synthesis and features investigation of mesoporous nanocrystalline titania.**

**Publication Date:** 2004

**Descriptors:** Titanium dioxide; Amorphous structure; Rutile; Nanostructure; Texture; Porosity; Surface area

**Subj Catg:** A2, Microstructure

7/8/1260 (Item 20 from file: 293)

Engineered Materials Abstracts

(c) 2009 CSA. All rights reserved.

0000274458 IP Accession No: 200506-C4-D-08853

**Multicolor photochromism of titanium dioxide loaded with silver nanoparticles**

**Publication Date:** 2004

**Descriptors:** Colors (materials); Silver; Photographic film; Titanium dioxide; Nanoparticles;

## Appendix A-5. Irrelevant Titles

Photochromism; Photoabsorption; Low cost; Free electrons; Photons; White light;  
Photocatalysis

**Subj Catg:** C4, Chemical and Electrochemical Properties

7/8/1261 (Item 21 from file: 293)

Engineered Materials Abstracts

(c) 2009 CSA. All rights reserved.

0000268655 IP Accession No: 200409-C4-C-0851

**Combustion synthesis of nanosized titania and its photocatalytic activity.**

**Publication Date:** 2004

**Descriptors:** Titanium dioxide; Nanomaterials; Combustion; Photocatalysis; Degradation

**Subj Catg:** C4, Chemical and Electrochemical Properties

7/8/1262 (Item 22 from file: 293)

Engineered Materials Abstracts

(c) 2009 CSA. All rights reserved.

0000262099 IP Accession No: 200402-E7-C-0109

**Preparation and structure characteristics of nanocrystalline titania porous films by sol-gel method.**

**Publication Date:** 2003

**Descriptors:** Titanium dioxide; Porous materials; Thin films; Sol gel process; Porosity

**Subj Catg:** E7, Surface Finishing

7/8/1263 (Item 23 from file: 293)

Engineered Materials Abstracts

(c) 2009 CSA. All rights reserved.

0000247310 IP Accession No: 200303-E4-C-0185

**Preparation of Nanometer Titanium Dioxide Powder**

**Publication Date:** 2002

**Descriptors:** Journal article; Titanium dioxide; Ceramic powders; Powder technology; Hydrolysis; Precipitation; Particle shape

**Subj Catg:** E4, Powder Technology

7/8/1264 (Item 24 from file: 293)

Engineered Materials Abstracts

(c) 2009 CSA. All rights reserved.

0000242354 IP Accession No: 200301-C1-C-0243

**Affects of alumina and titania nanoparticulates on bone cell function**

**Publication Date:** 2002

**Descriptors:** Conference paper; Titanium dioxide; Aluminum oxide; Biomedical materials; Surgical implants; Prosthetics; Biocompatibility; Wear resistance; Friction ; Nanoparticles; Bone cell function in presence of  $Al_2O_3$  and  $TiO_2$  particles ; Wear debris due to friction in

## Appendix A-5. Irrelevant Titles

orthopaedic implants; Alumina; Bone cell function in presence of nanoparticles; Titania; Biomedical applications; Bone cell function in presence of  $\text{Al}_2\text{O}_3$  and  $\text{TiO}_2$  nanoparticles; Nanophase ceramics as bone prostheses with improved osseointegration; Biomaterials; Aluminium oxide; **Analysis**; Bioceramic; Biological **process**

**Subj Catg:** C1, Mechanical Properties

7/8/1265 (Item 25 from file: 293)

Engineered Materials Abstracts

(c) 2009 CSA. All rights reserved.

0000240059 IP Accession No: 200210-E7-C-0475

**Characteristics and property of photo - catalytic nanocrystalline titanium dioxide film prepared by electrochemical oxidation**

**Publication Date:** 2002

**Descriptors:** Journal article; Titanium dioxide; Thin films; Nanomaterials; Photocatalysis; Kinetics

**Subj Catg:** E7, Surface Finishing

7/8/1266 (Item 1 from file: 315)

ChemEng & Biotech Abs

(c) 2009 DECHEMA. All rights reserved.

705237 0000705237

**Particle diameter prediction in supercritical nanoparticle synthesis using threedimensional CFD simulations. Validation for anatase titanium dioxide production**

**Original Title:** Vorhersage des Partikeldurchmessers bei der ueberkritischen Nanopartikelsynthese unter Verwendung dreidimensionaler CFD-Simulationen. Validierung am Beispiel der Anatas-TiO(sub 2)-Herstellung

**Descriptors (English):** CFD (computational fluid dynamics); titanium dioxide; nanoparticles; mathematical model; Reynolds number; particle-size; precursors; supercritical fluids

**Descriptors (German):** mathematisches Modell; numerische Stroemungssimulation; Titanoxid; Nanopartikel; Partikelgroesse; ueberkritisches Fluid; Kohlendioxid; Ethanol; Rohrreaktor; Zustandsgleichung; Mischungsregel; Temperatureinfluss; Druckabhaengigkeit; Dichte; Hydrodynamik; Materialbilanz; Energiebilanz; Kinetik; Reynolds-Zahl; Abweichung (Divergenz); Anatas; CFD-Simulation

**Section:** Kinetics and Thermodynamics ( 35 )

**Section Cross-Reference:** Physicochemical Properties (04)

**DECHEMA Classification:** Simulation methods, simulation models (3BAS); Nanotechnology, nanotubes (3QN); Chemical reactions, chemical reaction engineering (3PLC)

7/8/1267 (Item 2 from file: 315)

ChemEng & Biotech Abs

## Appendix A-5. Irrelevant Titles

(c) 2009 DECHEMA. All rights reserved.

693917 0000693917

### **One-pot synthesis of Ni-nanoparticle-embedded mesoporous titania/silica catalyst and its application for CO(sub 2)-reforming of methane**

**Original Title:** Einstufensynthese eines mesoporoesen Titandioxid/Siliciumdioxid-Katalysators mit eingebetteten Ni- **Nanopartikeln** und seine Anwendung fuer das CO(sub 2)-Reforming von Methan

**Descriptors (English):** catalytic reforming; catalyst activity; methane; syngas production; nanoparticles; properties (physicochemical); catalyst production; nickel ; particle size; carbon dioxide; fischer-tropsch synthesis; titanium dioxide; silica

**Descriptors (German):** heterogene Katalyse; Kohlendioxid; Methan; Synthese; Katalysatoraktivitaet

**Section:** Reaction Kinetics and Thermodynamics ( 03 )

**Section Cross-Reference:** Material Science (24)

**DECHEMA Classification:** Inorganic chemistry (fundamentals) ( 3BXA ) ; Chemical equilibrium, kinetics, catalysis, chemical solutions ( 3PLA ) ; Chemical reactions, chemical reaction engineering (3PLC) ; Chemical process-development, -modelling, -performance and -optimization ( 3PLD)

7/8/1268 (Item 3 from file: 315)

ChemEng & Biotec Abs

(c) 2009 DECHEMA. All rights reserved.

686827 0000686827

### **Effect of titanium dioxide solubility on the formation of BaTiO(sub 3) nanoparticles in supercritical water**

**Original Title:** Einfluss der Titandioxid-Loeslichkeit auf die Bildung von BaTiO(sub 3)-**Nanopartikeln** in ueberkritischem Wasser

**Descriptors (English):** supercritical flow; nanoparticles; solubility; hydrothermal reaction; dissolution (general); batch reactor

**Descriptors (German):** Titandioxid; Barium; Titanat; Nanopartikel; Praeparation; experimentell; BaTiO3-Nanopartikel; ueberkritisches Wasser; Bariumhydroxid

**Section:** Physicochemical Properties ( 04 )

**DECHEMA Classification:** Fluid dynamics (3BBS) ; Thermodynamics, statistical physics, heat flow (3BN) ; Nanotechnology, nanotubes (3QN) ; Phase diagrams of materials (3KWR)

7/8/1269 (Item 4 from file: 315)

ChemEng & Biotec Abs

(c) 2009 DECHEMA. All rights reserved.

685554 0000685554

## Appendix A-5. Irrelevant Titles

### **An integrated low temperature approach to highly photoactive nanocrystalline mesostructured titania**

**Original Title:** Herstellung eines photoaktiven, **nanokristallinen** mesostrukturierten Titanias mittels der integrierten Tieftemperaturmethode

**Descriptors (English):** titanium dioxide; sol-gel method; uv irradiation; crystal size; ceramics; photocatalysis; energy conservation; phase equilibrium; inorganic chemical **production**; catalyst **production**; ceramics **production**

**Descriptors (German):** Titandioxid; Struktur (Werkstoff); nanokristalliner Werkstoff; Synthese; Tieftemperatur; Anatas; UV-Bestrahlung; Mesostruktur; Photoaktivitaet

**Section:** Process Operation, Loss Prevention, and Optimization ( 02 )

**Section Cross-Reference:** Reaction Kinetics and Thermodynamics (03) ; Material Science (24)

**DECHEMA Classification:** Ceramic/refractory materials, glass ceramics (3KGG) ; Materials properties (3KX) ; Electrical/magnetic properties of materials (3KXE) ; Nanotechnology, nanotubes (3QN)

7/8/1270 (Item 5 from file: 315)

ChemEng & Biotec Abs

(c) 2009 DECHEMA. All rights reserved.

684701 0000684701

### **Strategically designed silica and silica-titania nanomaterials for high-tech applications**

**Original Title:** Strategisch entworfene Siliciumdioxid- und Siliciumdioxid-Titandioxid-Nanowerkstoffe fuer High-Tech-Anwendungen

**Descriptors (English):** silica; titanium dioxide; silicon; particle size; ceramics; ceramics **production**; catalyst **production**; sol-gel method; powder **production**; particle size measurement; ammoxidation

**Descriptors (German):** Siliciumdioxid; Titandioxid; nanokristalliner Werkstoff; Sol-Gel-Verfahren; TEOS (Tetraoxysilan); Nanopulver; Kugel; Korngroessenverteilung; Katalysator (Verfahrenstechnik); katalytische Oxidation; Cyclohexanon; Ketoxim; energiedispersive Spektrometrie; Nanokugel; Nanokatalysator

**Section:** Reaction Kinetics and Thermodynamics ( 03 )

**Section Cross-Reference:** Material Science (24)

**DECHEMA Classification:** Ceramic/refractory materials, glass ceramics (3KGG) ; Production/processing of non-metallic inorganic materials (3LEM) ; Nanotechnology, nanotubes (3QN) ; Crystal structure, material structure/textures (3KWG)

7/8/1271 (Item 6 from file: 315)

ChemEng & Biotec Abs

(c) 2009 DECHEMA. All rights reserved.

607550 0000607550

### **Synthesis of transparent solution with high concentrated nano titanium dioxide**

## Appendix A-5. Irrelevant Titles

**Original Title:** Die Synthese einer transparenten Loesung mit hoher Konzentration an dispergierten Nano-Titandioxiden

**Descriptors (English):** titanium dioxide; colloid; uv radiation; absorption; cosmetic; health and safety

**Descriptors (German):** Nano-Titandioxid; UV-Schutz; Nanopartikel; Nano-Cluster; Kolloidsysteme

**Section:** Reaction Kinetics and Thermodynamics ( 03 )

**DECHEMA Classification:** Production of organic chemical final products (3PLG) ; Ceramic/refractory materials, glass ceramics ( 3KGG)

7/8/1273 (Item 2 from file: 317)

Chemical Safety NewsBase

(c) 2009 Royal Soc Chemistry. All rights reserved.

00083515

**Behavioral and physiological changes in Daphnia magna when exposed to nanoparticle suspensions (titanium dioxide, nano-C60and C60HxC70Hx).**

**Publication Date:** 15 Jun 2007 ( 20070615 )

**Descriptors:** particles, nano- ; **environmental impact assessment** ; Daphnia magna ; ecotoxicity ; heart rate ; reprotoxins

**Chemical Substance:** ; titanium oxide (TiO<sub>2</sub>) (13463-67-7) ; fullerenes

**Section:** General and Miscellaneous Biological Effects ( 09 )

7/8/1275 (Item 1 from file: 323)

RAPRA Polymer Library

(c) 2010 RAPRA Technology Ltd. All rights reserved.

01051002

**Title: TEMPLATE-DIRECTED SYNTHESIS OF HYBRID TITANIA NANOWIRES WITHIN CORE-SHELL BISHYDROPHILIC CYLINDRICAL POLYMER BRUSHES**

**Descriptors:** AMORPHOUS; ANALYSIS

; ANIONIC POLYMERISATION; ANIONIC POLYMERIZATION; ATOM TRANSFER RADICAL POLYMERISATION; ATOM TRANSFER RADICAL POLYMERIZATION; ATOMIC FORCE MICROSCOPY; CORE-SHELL; CRYSTALLINE; CYLINDER; DATA; DISCRIMINANT ANALYSIS; ETHYLENE GLYCOL METHACRYLATE COPOLYMER; FRACTURE MORPHOLOGY; FREE RADICAL POLYMERISATION; GRAPH; HYBRID; HYDROLYSIS ; HYDROPHILIC; HYDROPHILICITY; HYDROXYETHYL METHACRYLATE COPOLYMER; INORGANIC; INSTITUTION; MORPHOLOGICAL PROPERTIES; MORPHOLOGY; NANOPARTICLE; NANOWIRE; NMR; NMR SPECTRA; NMR SPECTROSCOPY; NMR SPECTRUM; NUCLEAR MAGNETIC RESONANCE; PLASTIC; POLYMERIC BRUSH; POLYMERISATION; POLYMERIZATION; PYROLYSIS; RADICAL POLYMERISATION; RADICAL POLYMERIZATION; SCANNING ELECTRON MICROSCOPY; SOLUBILITY; SOLUBLE; SOLVENT; SYNTHESIS; TECHNICAL; TEM; TEMPLATE; TRANSMISSION ELECTRON MICROSCOPY; WATER SOLUBLE

## Appendix A-5. Irrelevant Titles

7/8/1276 (Item 2 from file: 323)

RAPRA Polymer Library

(c) 2010 RAPRA Technology Ltd. All rights reserved.

01049724

**Title: SYNTHESIS AND PROPERTIES OF PHOTSENSITIVE POLYIMIDE-NANOCRYSTALLINE TITANIA OPTICAL THIN FILMS**

**Descriptors:** CARBOXYLIC ACID COPOLYMER; COMPOSITE; COPOLYIMIDE; CURING; DOMAIN SIZE; FILM; FILMS; GRAFT COPOLYMER; GRAPH; IMIDE COPOLYMER; IMIDE POLYMER; INITIATION; INSTITUTION; LITHOGRAPHY; METHACRYLATE COPOLYMER; METHACRYLIC ESTER COPOLYMER; NANOCOMPOSITE; NANOCRYSTALLINE; NANODISPERSION; NANOFILLER ; NANOPARTICLE; NANOPHASE; OPTICAL PROPERTIES; ORGANIC-INORGANIC COMPOSITE; PATTERN; PATTERNING; PHOTOCROSSLINKING; PHOTOCURING; PHOTOINITIATION; PHOTOPATTERN; PHOTSENSITIVE; PHOTSENSITIVITY; POLYIMIDE; PROPERTIES; REFRACTIVE INDEX; REFRACTIVE INDICES; SENSITIVITY; SOLUBILITY; SOLUBLE; SYNTHESIS; TABLES; TECHNICAL; THIN FILM; THIN-FILM; TUNABLE; TWO-PHOTON 3D LITHOGRAPHY

7/8/1277 (Item 3 from file: 323)

RAPRA Polymer Library

(c) 2010 RAPRA Technology Ltd. All rights reserved.

01037187

**Title: PREPARATION AND CHARACTERIZATIONS OF A NOVEL TITANIUM DIOXIDE NANOPARTICLE SELF-ASSEMBLED MEMBRANE**

**Descriptors:** ABSORPTION; ANHYDRIDE GROUP; ANTIFOULING; ASSEMBLY; BLEND; CHARACTERISATION ; CHARACTERIZATION; COMPANIES; COMPANY; COMPOSITE; COMPOSITION; CONTACT ANGLE; DATA; DIFFRACTION; ELECTRON MICROGRAPH; ELECTROSTATIC; ESCA; FABRICATION; FRACTURE MORPHOLOGY; GRAPH; HYBRID; HYDROPHILIC; HYDROPHILICITY; INSTITUTION; MEASUREMENT; MEMBRANE; MORPHOLOGICAL PROPERTIES; MORPHOLOGY; NANOPARTICLE; NOVEL; PARTICLE SIZE; PHOTOELECTRON SPECTROSCOPY; PLASTIC; POLYVINYLIDENE FLUORIDE; PREPARATION; **PROCESSING** CONDITIONS; PROPERTIES; PROTEIN; PVDF; REINFORCED PLASTIC ; REINFORCED PLASTICS; SCANNING ELECTRON MICROSCOPY; SCATTERING; SELF-ASSEMBLY; SEM; SPECTRA; SPECTROSCOPY; STYRENE-MALEIC ANHYDRIDE COPOLYMER; SURFACE CHEMISTRY; SURFACE MODIFICATION; SURFACE PROPERTIES; SURFACE TREATMENT; TABLES; TECHNICAL; TEM; THERMOPLASTIC; TRANSMISSION ELECTRON MICROSCOPY; X-RAY DIFFRACTION; X-RAY PHOTOELECTRON SPECTROSCOPY; X-RAY SCATTERING; X-RAY SPECTRA; X-RAY SPECTROSCOPY

7/8/1278 (Item 4 from file: 323)

RAPRA Polymer Library

(c) 2010 RAPRA Technology Ltd. All rights reserved.

## Appendix A-5. Irrelevant Titles

01035271

**Title: ANTIBACTERIAL ELECTROSPUN CHITOSAN/POLY(VINYL ALCOHOL) NANOFIBERS CONTAINING SILVER NITRATE AND TITANIUM DIOXIDE**

**Descriptors:** ANTIBACTERIAL; BLEND; CHARACTERISATION; **CHARACTERIZATION**; CHITOSAN; DATA; DIAGRAM; ELECTRON MICROSCOPY; ELECTROSPINNING; EQUATION; FIBER; FIBRE ; FILAMENT; FILLER; FOURIER TRANSFORM INFRARED SPECTROSCOPY; FRACTURE MORPHOLOGY; FTIR SPECTROSCOPY; GRAPH; INSTITUTION; LASER INDUCED BREAKDOWN SPECTROSCOPY; MICROGRAPHY; MICROSCOPY; MOISTURE CONTENT; MORPHOLOGICAL PROPERTIES; MORPHOLOGY; NATURAL POLYMER; PLASTIC; POLYVINYL ALCOHOL; PRIOR TO 1995 THIS WAS A NON-POLYMER TERM; PVAL; RHEOLOGICAL PROPERTIES; SCANNING ELECTRON MICROSCOPY; SEM; SPECTRA; SPECTROSCOPY; TABLES; TECHNICAL; THERMOPLASTIC; VINYL ALCOHOL POLYMER; VISCOSITY; **WATER CONTENT**

7/8/1279 (Item 5 from file: 323)

RAPRA Polymer Library

(c) 2010 RAPRA Technology Ltd. All rights reserved.

01034667

**Title: FACILE SYNTHESIS OF HOLLOW ANATASE TITANIA PREPARED BY CHARGED POLYMERIC NANOSPHERE TEMPLATE**

**Descriptors:** ACRYLIC COPOLYMER; ADSORPTION; **APPLICATION**; CALCINATION; CATIONIC; CHEMICAL MODIFICATION; CHEMICAL REAGENT; COLLOID; CORE-SHELL; DATA; DIFFRACTION; DIMETHACRYLATE COPOLYMER; EMULSIFIER-FREE; EMULSION POLYMERISATION; EMULSION POLYMERIZATION; ETHYLENE GLYCOL DIMETHACRYLATE COPOLYMER; ETHYLENE GLYCOL-DIMETHACRYLATE COPOLYMER; GRAPH; HOLLOW; HYDROLYSIS; INITIATOR; INSTITUTION; METHACRYLOXYETHYLTRIMETHYLAMMONIUM CHLORIDE COPOLYMER; METHYL METHACRYLATE COPOLYMER; METHYLMETHACRYLATE COPOLYMER; MODIFICATION; NANOPARTICLE; NANOSPHERE; NITROGEN-CONTAINING POLYMER; PARTICLE SIZE; PLASTIC; POLYMERIC SUPPORT; POLYMERISATION; POLYMERISATION INITIATOR; POLYMERIZATION; POLYMERIZATION INITIATOR; PRECURSOR; SCANNING ELECTRON MICROSCOPY; SCATTERING; SEM; TABLES; TECHNICAL ; TEMPLATE; THERMOPLASTIC; X-RAY DIFFRACTION; X-RAY SCATTERING

7/8/1280 (Item 6 from file: 323)

RAPRA Polymer Library

(c) 2010 RAPRA Technology Ltd. All rights reserved.

01031964

**Title: IMMOBILIZATION OF COLLAGEN AND HYALURONIC ACID ON HYDROXYAPATITE/ TITANIA COMPOSITE NANOFIBERS FOR TISSUE ENGINEERING**

## Appendix A-5. Irrelevant Titles

**Descriptors:** APPLICATION; CELL ADHESION; CHARACTERISATION; CHARACTERIZATION; COLLAGEN; COMPOSITE; DATA; DIAGRAM; ELECTRON MICROSCOPY; ESCA; FIBER; FIBRE ; FILAMENT; FOURIER TRANSFORM INFRARED SPECTROSCOPY; FTIR SPECTROSCOPY; IMMOBILISATION; IMMOBILIZATION; IN-VITRO; INSTITUTION; LASER INDUCED BREAKDOWN SPECTROSCOPY; MEDICAL APPLICATION; MICROGRAPHY; MICROSCOPY ; NANOFIBER; NANOFIBRE; PHOTOELECTRON SPECTROSCOPY; PLASTIC; POLYVINYL PYRROLIDINONE; POLYVINYL PYRROLIDONE; POLYVINYL PYRROLIDINONE; POLYVINYL PYRROLIDONE; PYROLYSIS; SCANNING ELECTRON MICROSCOPY; SCATTERING; SEM; SPECTRA; SPECTROSCOPY; SPINNING; SURGICAL APPLICATION; SURGICAL GOWN; SYNTHESIS; TECHNICAL; THERMOPLASTIC; TISSUE ENGINEERING; VINYL PYRROLIDONE POLYMER; X-RAY DIFFRACTION; X-RAY PHOTOELECTRON SPECTROSCOPY; X-RAY SCATTERING; X-RAY SPECTRA; X-RAY SPECTROSCOPY

7/8/1281 (Item 7 from file: 323)

RAPRA Polymer Library

(c) 2010 RAPRA Technology Ltd. All rights reserved.

01028381

**Title: PREPARATION AND PROPERTIES OF KONJAC  
GLUCOMANNAN/TITANIUM DIOXIDE NANOCOMPOSITES**

**Descriptors:** CASTING; CHARACTERISATION; CHARACTERIZATION; DATA; DISPERSION; ELECTRON MICROSCOPY; FILLER; FILM; FILMS; FOURIER TRANSFORM INFRARED SPECTROSCOPY; FRACTURE MORPHOLOGY; FTIR SPECTROSCOPY; GRAPH; GRAVIMETRIC ANALYSIS; INSTITUTION; KONJAC GLUCOMANNAN; LASER INDUCED BREAKDOWN SPECTROSCOPY; MECHANICAL PROPERTIES; MICROGRAPHY; MICROSCOPY; MORPHOLOGICAL PROPERTIES; MORPHOLOGY; NATURAL POLYMER; PLASTIC; POLYSACCHARIDE; PROPERTIES; SCANNING ELECTRON MICROSCOPY; SPECTRA; SPECTROSCOPY; SUSPENSION ; TECHNICAL; TEM; TENSILE PROPERTIES; TGA; THERMAL GRAVIMETRIC ANALYSIS; THERMOGRAVIMETRIC ANALYSIS; THERMOPLASTIC; TRANSMISSION ELECTRON MICROSCOPY

7/8/1282 (Item 8 from file: 323)

RAPRA Polymer Library

(c) 2010 RAPRA Technology Ltd. All rights reserved.

01027644

**Title: MESOPOROUS NANOCRYSTALLINE TITANIUM DIOXIDE ELECTRODE  
WITH IONIC LIQUID-BASED SOLID POLYMER ELECTROLYTE FOR DYE-  
SENSITIZED SOLAR CELL APPLICATION**

**Descriptors:** APPLICATION; DATA; DIFFRACTION; ELECTRICAL APPLICATION; ELECTRICAL CONDUCTIVITY; ELECTRODE; FILM; FILMS; FRACTURE MORPHOLOGY; GRAPH ; INSTITUTION; IONIC CONDUCTIVITY; MEMBRANE;

## Appendix A-5. Irrelevant Titles

MORPHOLOGICAL PROPERTIES; MORPHOLOGY; OPTICAL **APPLICATION**;  
PHOTOVOLTAIC PROPERTIES; PLASTIC; POLYELECTROLYTE; PROPERTIES;  
SCANNING ELECTRON MICROSCOPY; SCATTERING; SEM; SOLAR CELL; SOLAR  
PANEL; TABLES; TECHNICAL; TEM; THEORY; THERMOPLASTIC;  
TRANSMISSION ELECTRON MICROSCOPY; X-RAY DIFFRACTION; X-RAY  
SCATTERING

7/8/1283 (Item 9 from file: 323)

RAPRA Polymer Library

(c) 2010 RAPRA Technology Ltd. All rights reserved.

01027629

**Title: PHOTSENSITIVE HIGH-REFRACTIVE-INDEX POLYACRYLIC ACID-  
GRAFT-POLYETHYLENE GLYCOL METHACRYLATE NANOCRYSTALLINE  
TITANIA HYBRID FILMS**

**Descriptors:** ACRYLIC ACID COPOLYMER; ATOMIC FORCE MICROSCOPY;  
CHEMICAL STRUCTURE; CHROMATOGRAPHY; DATA; DIFFRACTION;  
ELLIPSOMETRY; ETHYLENE GLYCOL METHACRYLATE COPOLYMER; FILM;  
FILMS; FRACTURE MORPHOLOGY; GEL PERMEATION CHROMATOGRAPHY;  
GPC; GRAPH; GRAVIMETRIC ANALYSIS; INSTITUTION; LITHOGRAPHY;  
MOLECULAR STRUCTURE; MORPHOLOGICAL PROPERTIES; MORPHOLOGY;  
OPTICAL PROPERTIES; PHOTSENSITIVITY; PLASTIC; PROPERTIES;  
REFRACTIVE INDEX; REFRACTIVE INDICES; SCANNING ELECTRON  
MICROSCOPY; SCATTERING; SENSITIVITY; SURFACE PROPERTIES; SURFACE  
TREATMENT; TABLES; TECHNICAL; TEM; TGA; THEORY; THERMAL  
GRAVIMETRIC ANALYSIS; THERMOGRAVIMETRIC ANALYSIS;  
THERMOPLASTIC; TRANSMISSION ELECTRON MICROSCOPY;  
TRIMETHOXYSILYLPROPYL METHACRYLATE COPOLYMER; TWO-PHOTON 3D  
LITHOGRAPHY; X-RAY DIFFRACTION; X-RAY SCATTERING

7/8/1284 (Item 10 from file: 323)

RAPRA Polymer Library

(c) 2010 RAPRA Technology Ltd. All rights reserved.

01024705

**Title: WATER VAPOR PERMEABILITY OF THE POLYURETHANE/TITANIUM  
DIOXIDE NANOHYBRID MEMBRANE WITH TEMPERATURE SENSITIVITY**

**Descriptors:** COLOURANT; COMPOSITE; DATA; DIFFERENTIAL THERMAL  
ANALYSIS; DSC; FILLER; FOURIER TRANSFORM INFRARED SPECTROSCOPY;  
FRACTURE MORPHOLOGY; FTIR; GRAPH; INFRA-RED SPECTRA; INFRARED  
SPECTRA; INFRARED SPECTROPHOTOMETRY; INFRARED SPECTROSCOPY;  
INSTITUTION; IR SPECTRA; IR SPECTROMETRY; IR SPECTROSCOPY; IR  
SPECTRUM; MEMBRANE; MORPHOLOGICAL PROPERTIES; MORPHOLOGY;  
PIGMENT; PLASTIC; POLYURETHANE; PU; REINFORCED PLASTIC; REINFORCED  
PLASTICS ; SCANNING ELECTRON MICROSCOPY; SEM; SOLVENT;  
SPECTROSCOPY; TABLES; TECHNICAL; THEORY; THERMOPLASTIC; VAPOUR  
PERMEABILITY; VIBRATIONAL SPECTROSCOPY; **WATER VAPOR**

## Appendix A-5. Irrelevant Titles

PERMEABILITY; WATER VAPOUR PERMEABILITY

7/8/1285 (Item 11 from file: 323)

RAPRA Polymer Library

(c) 2010 RAPRA Technology Ltd. All rights reserved.

01020812

**Title: SYNTHESIS OF HOLLOW SILICA AND TITANIA NANOSPHERES**

**Descriptors:** ADSORPTION; ANALYSIS; **APPLICATION**; BEAD; BEADS; BIOMEDICAL **APPLICATION**; CALCINATION; CATALYSIS; CHEMICAL MODIFICATION; CONDENSATION POLYMERISATION; CORE; DATA; DISCRIMINANT ANALYSIS; DISSOLUTION ; ELECTRON MICROSCOPY; ELECTRON SCANNING MICROSCOPY; FUNCTIONALISATION; FUNCTIONALIZATION; GRAPH; HOLLOW; INSTITUTION; LYSINE POLYMER; MEDICAL

**APPLICATION**; MODIFICATION; MONODISPERSE; NANOSPHERE; PARTICLE SIZE; PLASTIC; POLYCONDENSATION; POLYLYSINE; POLYSTYRENE; PS; SCANNING ELECTRON MICROGRAPH; SCANNING ELECTRON MICROSCOPY; SEM; SOLVENT; SURGICAL **APPLICATION**; SURGICAL GOWN; TABLES; TECHNICAL; TEM; TEMPLATE; THERMOPLASTIC; TRANSMISSION ELECTRON MICROSCOPY

7/8/1286 (Item 12 from file: 323)

RAPRA Polymer Library

(c) 2010 RAPRA Technology Ltd. All rights reserved.

01009711

**Title: NOVEL POLYMETHYLPENTYNE/TITANIUM DIOXIDE HYBRID NANOCOMPOSITE MEMBRANE FOR NATURAL GAS CONDITIONING. BUTANE/METHANE SEPARATION**

**Descriptors:** **APPLICATION**; CHEMICAL STRUCTURE; CHROMATOGRAPHY; COMPOSITE; DATA; ENERGY **APPLICATION**; FILLER; GAS TRANSPORT; GEL PERMEATION CHROMATOGRAPHY; GPC; GRAPH; INSTITUTION; MEMBRANE; MOLEC.WT.; MOLECULAR MASS; MOLECULAR STRUCTURE; MOLECULAR WEIGHT; NANOCOMPOSITE; NMR; NMR SPECTRA; NMR SPECTROSCOPY; NMR SPECTRUM; NUCLEAR MAGNETIC RESONANCE; PERMEABILITY; PLASTIC; POLYMERISATION MECHANISM; POLYMERIZATION MECHANISM; POLYMETHYLPENTYNE; REINFORCED PLASTIC; REINFORCED PLASTICS; RHEOLOGICAL PROPERTIES; RHEOLOGY; TABLES; TECHNICAL; THEORY; THERMOPLASTIC; VISCOSITY

7/8/1288 (Item 14 from file: 323)

RAPRA Polymer Library

(c) 2010 RAPRA Technology Ltd. All rights reserved.

01002272

## Appendix A-5. Irrelevant Titles

**Title: PREPARATION OF NANOCRYSTALLINE POROUS TITANIA FILMS ON TITANIUM SUBSTRATES BY A SOL-GEL METHOD WITH POLYETHYLENE GLYCOL AS A TEMPLATE**

**Descriptors:** ADSORPTION; **APPLICATION**; ASSEMBLY; BIOMEDICAL **APPLICATION**; CONCENTRATION; DATA; DIFFERENTIAL THERMAL ANALYSIS; DIFFRACTION; DTA; ETHER POLYMER; ETHYLENE GLYCOL POLYMER; FILM; FILMS; GRAPH; GRAVIMETRIC ANALYSIS; INSTITUTION; MEDICAL **APPLICATION**; MOLEC.WT.; MOLECULAR MASS; MOLECULAR WEIGHT; NANOCRYSTALLINE; PHASE SEPARATION; PLASTIC; POLYETHER; POLYETHYLENE GLYCOL; POLYMERIC SUPPORT; POROUS; PREPARATION; SCANNING ELECTRON MICROSCOPY; SCATTERING; SELF-ASSEMBLY; SEM; SOL-GEL; SURGICAL **APPLICATION**; SURGICAL GOWN; TABLES; TECHNICAL; TEMPLATE; TGA; THERMAL GRAVIMETRIC ANALYSIS; THERMOGRAVIMETRIC ANALYSIS; THERMOPLASTIC; X-RAY DIFFRACTION; X-RAY SCATTERING; XEROGEL

7/8/1289 (Item 15 from file: 323)

RAPRA Polymer Library

(c) 2010 RAPRA Technology Ltd. All rights reserved.

00996681

**Title: PREPARATION AND CHARACTERIZATION OF POLY(IMIDE SILOXANE) (PIS)/ TITANIA(TIO<sup>2</sup>) HYBRID NANOCOMPOSITES BY SOL-GEL PROCESSES**

**Descriptors:** ATOMIC FORCE MICROSCOPY; CALORIMETRY; CHARACTERISATION; CHARACTERIZATION; CHEMICAL STRUCTURE; CHROMATOGRAPHIC ANALYSIS; CHROMATOGRAPHY; CLARITY; COPOLYIMIDE; DATA; DIFFERENTIAL THERMAL ANALYSIS; DIPHENYL GROUP; DMA; DSC; DYNAMIC MECHANICAL ANALYSIS; E-MODULUS; ELASTIC MODULUS; ESCA; FILLER; FILM ; FILMS; FOURIER TRANSFORM INFRARED SPECTROSCOPY; FTIR SPECTROSCOPY; GEL PERMEATION CHROMATOGRAPHY; GLASS TRANSITION; GLASS TRANSITION TEMPERATURE; GPC; GRAPH; GRAVIMETRIC ANALYSIS; HEAT RESISTANCE; HOMOGENEITY; HYDRODYNAMIC CHROMATOGRAPHY; IMIDE COPOLYMER; INSTITUTION; LASER INDUCED BREAKDOWN SPECTROSCOPY; LIGHT TRANSMISSION; MECHANICAL PROPERTIES; MICROGRAPHY; MICROSCOPY; MOLEC.WT.; MOLECULAR MASS; MOLECULAR STRUCTURE; MOLECULAR WEIGHT; NANOCOMPOSITE; OPTICAL PROPERTIES; PACKED COLUMN HYDRODYNAMIC CHROMATOGRAPHY; PHOTOELECTRON SPECTROSCOPY; PLASTIC; PYROLYSIS COMBUSTION FLOW CALORIMETRY; SCANNING ELECTRON MICROSCOPY; SEGMENT; SILICON COPOLYMER; SILICON-CONTAINING COPOLYMER; SILICONE COPOLYMER; SILOXANE COPOLYMER; SOL-GEL; SPECTRA; SPECTROSCOPY; STABILITY; SYNTHESIS; TABLES; TECHNICAL; TEM; TENSILE PROPERTIES; TENSILE STRENGTH; TG; TGA; THERMAL GRAVIMETRIC ANALYSIS; THERMAL RESISTANCE; THERMAL STABILITY; THERMOGRAVIMETRIC ANALYSIS; THERMOOXIDATIVE STABILITY; THERMOPLASTIC; TRANSLUCENCY; TRANSMISSION ELECTRON MICROSCOPY; TRANSPARENCY; UV SPECTROSCOPY; UV VIS SPECTROSCOPY; VISIBLE SPECTRA; VISIBLE SPECTROSCOPY; X-RAY PHOTOELECTRON SPECTROSCOPY;

## Appendix A-5. Irrelevant Titles

X-RAY SPECTRA; X-RAY SPECTROSCOPY; YOUNG'S MODULUS

7/8/1290 (Item 16 from file: 323)

RAPRA Polymer Library

(c) 2010 RAPRA Technology Ltd. All rights reserved.

00988785

**Title: HYPERBRANCHED POLYMER/TITANIUM DIOXIDE HYBRID NANOPARTICLES SYNTHESIZED VIA AN IN SITU SOL-GEL PROCESS**

**Descriptors:** ALIPHATIC POLYESTER; AROMATIC; ATOMIC FORCE MICROSCOPY; CHARACTERISATION; CHARACTERIZATION; CHEMICAL STRUCTURE; CHROMATOGRAPHY; COATING; COMPOSITE; CURING; DATA; DENDRITIC; DISPERSION; DYNAMIC LIGHT SCATTERING; FRACTURE MORPHOLOGY; FUNCTIONAL GROUP; GEL CHROMATOGRAPHY; GEL PERMEATION CHROMATOGRAPHY; GPC; GRAPH; GRAVIMETRIC ANALYSIS; HARDNESS; HYBRID COMPOSITE; HYPERBRANCHED; IN-SITU; INSTITUTION; INTERACTION; INTERFACIAL INTERACTION; INTERFACIAL PROPERTIES; LIGHT SCATTERING; LIGHT-SCATTERING; MATRIX; MECHANICAL PROPERTIES; MOLECULAR STRUCTURE; MORPHOLOGICAL PROPERTIES; MORPHOLOGY; NANOCOMPOSITE; NMR; NMR SPECTRA; NMR SPECTROSCOPY; NMR SPECTRUM; NUCLEAR MAGNETIC RESONANCE; ORGANIC-INORGANIC COMPOSITE; PLASTIC; PROPERTIES; REINFORCED PLASTIC; REINFORCED PLASTICS; SCATTERING; SMALL ANGLE X-RAY SCATTERING; SOL-GEL; SURFACE MODIFICATION; SURFACE TREATMENT; SYNTHESIS; TABLES; TECHNICAL; TEST METHOD; TESTING; TGA; THEORY; THERMAL CURING; THERMAL GRAVIMETRIC ANALYSIS; THERMAL PROPERTIES; THERMOGRAVIMETRIC ANALYSIS; THERMOSET; X-RAY DIFFRACTION; X-RAY SCATTERING

7/8/1291 (Item 17 from file: 323)

RAPRA Polymer Library

(c) 2010 RAPRA Technology Ltd. All rights reserved.

00982220

**Title: NANOTUBINGS OF TITANIA/POLYMER COMPOSITE: TEMPLATE SYNTHESIS AND NANOPARTICLE INCLUSION**

**Descriptors:** ADDITIVE; APPLICATION; ASSEMBLY; CERAMIC; COLLOID; COMPOSITE; DATA; ENCAPSULATION; FILLER; FILM; FLEXIBILITY; FLEXIBLE; FRACTURE MORPHOLOGY; INCLUSION; INSTITUTION; LATEX; LATICES; MECHANICAL PROPERTIES; MEMBRANE; MESOPOROUS; MICROSHERE; MORPHOLOGICAL PROPERTIES; MORPHOLOGY; NANOCOMPOSITE; NANOPARTICLE; NANOTUBE; PLASMA TREATMENT; PLASTIC; POROUS; PROPERTIES; SCANNING ELECTRON MICROSCOPY; SEM; SPHERE; SYNTHESIS; TABLES; TECHNICAL; TEMPLATE; THERMOPLASTIC; THIN FILM; THIN-FILM

## Appendix A-5. Irrelevant Titles

7/8/1292 (Item 18 from file: 323)

RAPRA Polymer Library

(c) 2010 RAPRA Technology Ltd. All rights reserved.

00980140

**Title: EFFECT OF NANO-TITANIUM DIOXIDE ON MECHANICAL PERFORMANCE OF SILICONE RUBBER REINFORCED WITH MQ RESIN UNDER PROTON RADIATION**

**Descriptors:** COLOR; COLOUR; DAMAGE; DATA; ELASTOMER; FRACTURE MORPHOLOGY; GRAPH; HARDNESS; INSTITUTION; MECHANICAL PROPERTIES; MORPHOLOGICAL PROPERTIES; MORPHOLOGY; MQ RESIN; NANOFILLER; PROPERTIES; PROTON IRRADIATION; REINFORCED RUBBER; RUBBER; SILICON ELASTOMER; SILICON RUBBER; SILICONE ELASTOMER; SILICONE RUBBER; STORAGE MODULUS; SURFACE PROPERTIES; TABLES; TECHNICAL; TENSILE PROPERTIES; TENSILE STRENGTH

7/8/1293 (Item 19 from file: 323)

RAPRA Polymer Library

(c) 2010 RAPRA Technology Ltd. All rights reserved.

00977670

**Title: PREPARATION OF N-BUTYL-PYRIDINIUM NITRATE/SPAN80-TWEEN80/TOLUENE MICROEMULSION AND ITS APPLICATION IN SYNTHESIS OF TITANIUM DIOXIDE NANOPARTICLES**

**Trade Names:** SPAN80; TWEEN80

**Descriptors:** CHEMICAL STRUCTURE; COMPANIES; COMPANY; COMPOSITE; DATA; ELASTOMER; ELECTRICAL CONDUCTIVITY; ELECTRON MICROGRAPH; EMULSION; FRACTURE MORPHOLOGY ; GRAPH; IMAGING; INSTITUTION; IONIC; KEY ARTICLE; LIQUID; MICROEMULSION; MOLECULAR STRUCTURE; MORPHOLOGICAL PROPERTIES; MORPHOLOGY; NANOPARTICLE; PARTICLE SIZE; PLASTIC; POLAR SOLVENT; PREPARATION; **PROCESSING** CONDITIONS; PROPERTIES; REACTION CONDITIONS; REINFORCED PLASTIC; REINFORCED PLASTICS; RUBBER; SCANNING ELECTRON MICROSCOPY; SOLVENT; SURFACE ACTIVE AGENT; SURFACTANT; SYNTHESIS; TECHNICAL; TEM; THERMOPLASTIC; THERMOSET; TRANSMISSION ELECTRON MICROSCOPY; WATER-IN-OIL

7/8/1294 (Item 20 from file: 323)

RAPRA Polymer Library

(c) 2010 RAPRA Technology Ltd. All rights reserved.

00977371

**Title: BISMALEIMIDODIPHENYL METHANE MODIFIED NOVOLAK RESIN/TITANIA NANOCOMPOSITES. PREPARATION AND PROPERTIES**

**Descriptors:** CHEMICAL MODIFICATION; CHEMICAL STRUCTURE; COMPOSITE; DATA; DMA; DYNAMIC MECHANICAL ANALYSIS; FILLER; FOURIER TRANSFORM INFRARED SPECTROSCOPY; FRACTURE; FRACTURE

## Appendix A-5. Irrelevant Titles

MORPHOLOGY; FTIR; GLASS TRANSITION TEMPERATURE; GRAPH; HEAT RESISTANCE; INFRA-RED SPECTRA; INFRARED SPECTRA; INFRARED SPECTROPHOTOMETRY; INFRARED SPECTROSCOPY; INSTITUTION; IR SPECTRA; IR SPECTROMETRY; IR SPECTROSCOPY; IR SPECTRUM; MODIFICATION; MOLECULAR STRUCTURE; MORPHOLOGICAL PROPERTIES; MORPHOLOGY; NMR; NMR SPECTRA; NMR SPECTROSCOPY; NMR SPECTRUM; NOVOLAC POLYMER; NOVOLAC RESIN; NOVOLAK POLYMER ; NUCLEAR MAGNETIC RESONANCE; OPTICAL PROPERTIES; PLASTIC; PROPERTIES; REINFORCED PLASTIC; REINFORCED PLASTICS; SCANNING ELECTRON MICROSCOPY; SEM; SPECTROSCOPY; STABILITY; TABLES; TECHNICAL; TEM; TG; THEORY; THERMAL PROPERTIES; THERMAL STABILITY; THERMOSET; TRANSMISSION ELECTRON MICROSCOPY; VIBRATIONAL SPECTROSCOPY

7/8/1295 (Item 21 from file: 323)

RAPRA Polymer Library

(c) 2010 RAPRA Technology Ltd. All rights reserved.

00971118

**Title: NANOSIZED-HYBRID COLLOIDS OF POLY(ACRYLIC ACID)/TITANIA VIA IN-SITU SOL-GEL REACTION**

**Descriptors:** ACRYLIC ACID POLYMER; ACRYLIC POLYMER; ADDITIVE; AGGREGATION; CHELATE; COLLOID; COMPOSITE; CONCENTRATION; CONDENSATION POLYMERISATION; DATA; FILLER; FOURIER TRANSFORM INFRARED SPECTROSCOPY; FTIR; GRAPH; GRAVIMETRIC ANALYSIS; HYDROLYSIS; IN-SITU; INFRA-RED SPECTRA; INFRARED SPECTRA; INFRARED SPECTROPHOTOMETRY; INFRARED SPECTROSCOPY; INSTITUTION; IR SPECTRA; IR SPECTROMETRY; IR SPECTROSCOPY; IR SPECTRUM; ORGANIC-INORGANIC COMPOSITE; PARTICLE SIZE; PLASTIC; POLYACRYLIC ACID; POLYCONDENSATION; PRECURSOR; PROPERTIES; SCANNING ELECTRON MICROSCOPY; SEM; SOL-GEL REACTION; SOLUTION; SPECTROSCOPY; STOICHIOMETRY; TABLES; TECHNICAL; TGA; THERMAL GRAVIMETRIC ANALYSIS; THERMOGRAVIMETRIC ANALYSIS; THERMOPLASTIC; VIBRATIONAL SPECTROSCOPY

7/8/1296 (Item 22 from file: 323)

RAPRA Polymer Library

(c) 2010 RAPRA Technology Ltd. All rights reserved.

00970940

**Title: RHEOLOGY AND DISPERSION BEHAVIOR OF HIGH-IMPACT POLYSTYRENE/ETHYLENE-VINYL ACETATE COPOLYMER/TITANIUM DIOXIDE NANOCOMPOSITES**

**Trade Names:** HIPS 466F; EVA 334N

**Descriptors:** ABSORPTION SPECTRA; ATOMIC FORCE MICROSCOPY; COMPANIES; COMPANY; COMPOSITE; COMPOSITION; DATA; DISPERSION; ELECTRON MICROGRAPH; ETHYLENE-VINYL ACETATE COPOLYMER; EVA; FILLER CONTENT; FLOW; FRACTURE MORPHOLOGY; GRAPH; HIGH IMPACT PS;

## Appendix A-5. Irrelevant Titles

HIGH-IMPACT PS; IMAGING; INSTITUTION; MASTERBATCH; MECHANICAL PROPERTIES; MELT COMPOUNDING; MORPHOLOGICAL PROPERTIES; MORPHOLOGY; NANOCOMPOSITE; NANOPARTICLE; PLASTIC; **PROCESSING** CONDITIONS; PROPERTIES; REACTION CONDITIONS; REINFORCED PLASTIC; REINFORCED PLASTICS; RHEOLOGICAL PROPERTIES; RHEOLOGY; RHEOMETRY; SCANNING ELECTRON MICROSCOPY; SHEAR RATE; SPECTROSCOPY; SURFACE MORPHOLOGY; SURFACE PROPERTIES; SYNTHESIS ; TECHNICAL; TEM; THERMOPLASTIC; TRANSMISSION ELECTRON MICROSCOPY; UV SPECTROSCOPY; UV VIS SPECTROSCOPY; VISCOSITY; VISIBLE SPECTRA; VISIBLE SPECTROSCOPY

7/8/1297 (Item 23 from file: 323)

RAPRA Polymer Library

(c) 2010 RAPRA Technology Ltd. All rights reserved.

00915962

**Title: PREPARATION OF PA6/NANO TITANIUM DIOXIDE(TiO<sub>2</sub>) COMPOSITES AND THEIR SPINNABILITY**

**Descriptors:** ADDITIVE; AGGLOMERATION; AMIDE POLYMER; ANCHORED; CAPROLACTAM POLYMER; COMPOSITE; COMPOUNDING; COUPLING AGENT; DATA; DEGREE OF DISPERSION; DISPERSION; DISPERSIVITY; EXTRUDING; EXTRUSION; FIBER; FIBRE; FILLER; GRAPH ; HOMOGENEOUS; INSTITUTION; MECHANICAL PROPERTIES; MELT; MELTS; NANOCOMPOSITE; NYLON; NYLON-6; PLASTIC; POLY-EPSILON-CAPROLACTAM; POLYAMIDE ; POLYAMIDE-6; POLYCAPROAMIDE; POLYCAPROLACTAM; PREPARATION; **PROCESS** ; **PROCESSING**; PROPERTIES; SOL; SPINNING; SURFACE MODIFICATION; SURFACE PROPERTIES; SURFACE TREATMENT; TABLES; TECHNICAL; THERMOPLASTIC

7/8/1298 (Item 24 from file: 323)

RAPRA Polymer Library

(c) 2010 RAPRA Technology Ltd. All rights reserved.

00904183

**Title: NANOSCALE TITANIUM DIOXIDE COATINGS APPLIED TO ELECTROSPUN NANOFIBRES**

**Descriptors:** ACRYLONITRILE POLYMER; CATALYST; COATED FABRIC; COATED FIBER; COATED FIBRE; COATING; COMPANIES; COMPANY; DATA; DEPOSITION; ELECTRODE; ELECTRON MICROGRAPH; ELECTROSPINNING; ENERGY DISPERSIVE SPECTROSCOPY; FABRIC; FIBRE; GRAPH; INSTITUTION; MEMBRANE; NANOFIBER; NANOFIBRE; PAN; PLASTIC; POLYACRYLONITRILE; POLYVINYL CYANIDE; **PROCESSING** CONDITIONS; SENSOR; SOLUTION; SPECTROSCOPY; SURFACE AREA; TECHNICAL; TEM; TEMPLATE; THERMOPLASTIC; TRANSMISSION ELECTRON MICROSCOPY

7/8/1299 (Item 25 from file: 323)

## Appendix A-5. Irrelevant Titles

RAPRA Polymer Library

(c) 2010 RAPRA Technology Ltd. All rights reserved.

00885765

**Title: THE SYNTHESIS AND MORPHOLOGY CHARACTERISTIC STUDY OF BAO-ODPA POLYIMIDE/ TITANIUM DIOXIDE NANO HYBRID FILMS**

**Descriptors:** CHARACTERISATION; CHARACTERIZATION; COMPOSITE; DATA; DIFFRACTION; DIFFRACTION PATTERN; DISPERSION; FILLER; FILM; FILMS; FOURIER TRANSFORM INFRARED SPECTROSCOPY; FRACTURE MORPHOLOGY; FTIR SPECTROSCOPY; GRAPH; GRAVIMETRIC ANALYSIS; HYBRID; IMIDE POLYMER; INSTITUTION; MICROGRAPHY; MICROSCOPY; MORPHOLOGICAL PROPERTIES; MORPHOLOGY; OPTICAL PROPERTIES; PHOTOELECTRON SPECTROSCOPY; PLASTIC; POLYIMIDE; SPECTROSCOPY; TABLES; TECHNICAL; TEM; TGA; THERMAL GRAVIMETRIC ANALYSIS; THERMOGRAVIMETRIC ANALYSIS; THERMOPLASTIC; TRANSMISSION ELECTRON MICROSCOPY; TRANSPARENCY; UV SPECTROSCOPY; UV VIS SPECTROSCOPY; VISIBLE SPECTROSCOPY; X-RAY DIFFRACTION; X-RAY PHOTOELECTRON SPECTROSCOPY; X-RAY SCATTERING; X-RAY SPECTROSCOPY

7/8/1300 (Item 26 from file: 323)

RAPRA Polymer Library

(c) 2010 RAPRA Technology Ltd. All rights reserved.

00884400

**Title: TITANIA/POLYPYRROLE HYBRID COMPOSITES BUILT FROM IN-SITU GENERATED ORGANICALLY FUNCTIONALISED NANOANATASE BUILDING BLOCKS**

**Descriptors:** DATA; ELECTROINITIATED POLYMERISATION; ELECTRON MICROSCOPY; ELECTRON SCANNING MICROSCOPY; ELECTROPOLYMERISATION; ELECTROPOLYMERIZATION; GEL; GELS; GRAPH; HYBRID; INSTITUTION; MODIFIER; NANOCOMPOSITE; PARTICLE SIZE; PLASTIC; POLYMERISATION; POLYMERIZATION; POLYPYRROLE; PYRROLE POLYMER; SCANNING ELECTRON MICROGRAPH; SCANNING ELECTRON MICROSCOPY; SEM; SOLUBILITY ; TABLES; TECHNICAL; THERMOPLASTIC; THERMOSET; TRANSMISSION ELECTRON MICROSCOPY

7/8/1301 (Item 27 from file: 323)

RAPRA Polymer Library

(c) 2010 RAPRA Technology Ltd. All rights reserved.

00875604

**Title: FABRICATION OF CONTROLLABLE ULTRATHIN HOLLOW SHELLS BY LAYER-BY-LAYER ASSEMBLY OF EXFOLIATED TITANIA NANOSHEETS ON POLYMER TEMPLATES**

**Descriptors:** ACRYLIC POLYMER; ALKENE POLYMER; APPLICATION; AROMATIC; ASSEMBLY; CALCINATION; CHEMICAL MODIFICATION; COLLOID; CORE-SHELL; DATA; ETHYLENIMINE POLYMER; EXFOLIATION; FABRICATION; GRAPH; HOLLOW; INSTITUTION; NITROGEN-CONTAINING POLYMER; OLEFIN

## Appendix A-5. Irrelevant Titles

POLYMER; OPTICAL PROPERTIES; PLASTIC; PMMA; POLYALKENE;  
POLYETHYLENE IMINE; POLYETHYLENEIMINE; POLYETHYLENIMINE;  
POLYMERIC SUPPORT; POLYMETHYL METHACRYLATE; POLYOLEFIN;  
POLYSTYRENE; PROPERTIES; PS; SCANNING ELECTRON MICROSCOPY; SEM;  
TABLES; TECHNICAL; TEMPLATE; THERMOPLASTIC; THICKNESS; ULTRA-THIN;  
ULTRAVIOLET IRRADIATION; UV IRRADIATION; X-RAY DIFFRACTION; X-RAY  
SCATTERING

7/8/1302 (Item 28 from file: 323)

RAPRA Polymer Library

(c) 2010 RAPRA Technology Ltd. All rights reserved.

00857637

**Title: CHARACTERIZATION OF POLY(VINYLDENE FLUORIDE-CO-  
HEXAFLUOROPROPYLENE)-BASED POLYMER ELECTROLYTE FILLED  
WITH TITANIUM DIOXIDE NANOPARTICLES**

**Descriptors:** ABSORPTION; **APPLICATION**; BATTERY; CHARACTERISATION;  
CHARACTERIZATION ; CHEMICAL STABILITY; COMPANIES; COMPANY;  
COMPATIBILITY; COMPOSITION; CRYSTALLINITY; CRYSTALLISATION;  
CRYSTALLIZATION; CYCLIC VOLTAMMETRY; DATA; DIFFERENTIAL THERMAL  
ANALYSIS; DSC; ELECTRICAL **APPLICATION**; ELECTRICAL CONDUCTIVITY;  
ELECTRICAL PROPERTIES; ELECTROCHEMICAL; ELECTROCHEMICAL  
PROPERTIES; ELECTROLYTE; ELECTRON MICROGRAPH; FILLER; FILM; FILMS;  
GRAPH; IMPEDANCE; INSTITUTION; INTERFACE; IONIC CONDUCTIVITY;  
MORPHOLOGICAL PROPERTIES; MORPHOLOGY; NANOPARTICLE;  
OPTIMISATION; OPTIMIZATION; PLASTIC; PROPERTIES; RECHARGEABLE;  
SCANNING ELECTRON MICROSCOPY; SEM; SOLUTION; SPECTRA; STABILITY;  
SURFACE MORPHOLOGY; SURFACE PROPERTIES; SWELLING; TECHNICAL;  
TEMPERATURE; THERMAL PROPERTIES; THERMOGRAM; THERMOPLASTIC;  
VINYLDENE FLUORIDE-HEXAFLUOROPROPYLENE COPOLYMER;  
VOLTAMMETRY

7/8/1303 (Item 29 from file: 323)

RAPRA Polymer Library

(c) 2010 RAPRA Technology Ltd. All rights reserved.

00827457

**Title: STUDY OF THE MECHANICAL AND PERMEABILITY PROPERTIES OF  
NANO- AND MICRON-TITANIUM DIOXIDE FILLED EPOXY COMPOSITES**

**Descriptors:** ADDITIVE; COMPOSITE; CONCENTRATION; DATA; EPOXIDE RESIN;  
EPOXY RESIN; FAILURE; FILLER; GRAPH; INSTITUTION; MECHANICAL  
PROPERTIES; MODULI; MODULUS ; NANOCOMPOSITE; NANOPARTICLE;  
PERMEABILITY; PLASTIC; POLYEPOXIDE; **PROCESS**; **PROCESSING**;  
PROPERTIES; SCRATCH RESISTANCE; STRAIN; SWELLING RESISTANCE;  
TABLES; TECHNICAL; THERMOSET; TOUGHNESS; ULTRASONIC

## Appendix A-5. Irrelevant Titles

7/8/1304 (Item 1 from file: 335)

Ceramic Abstracts/World Ceramics Abstracts

(c) 2009 CSA. All rights reserved.

0000405008 IP Accession No: 85-26128

**Nanometer Titanium Dioxide Powder Preparation and Its Performance Investigation**

**Publication Date: 2005**

**Descriptors:** Grains; Titanium dioxide; Sol gel **process**; Crystals; Anatase; Rutile ;  
Methylene blue; Transmission electron microscopy; Degradation; Assessments; Standards;  
Combustion; Photocatalysis

**Subj Catg:** 15A, Oxides

7/8/1305 (Item 2 from file: 335)

Ceramic Abstracts/World Ceramics Abstracts

(c) 2009 CSA. All rights reserved.

0000372056 IP Accession No: 84-15289

**NOVEL APPROACH TO SYNTHESIS OF HIGH-DISPERSED ANATASE TITANIA NANOCRYSTALS**

**Publication Date: 2005**

**Descriptors:** Titanium dioxide; Anatase; Nanocrystals; Synthesis; Agglomeration; Melting;  
Transmission electron microscopy; Sol-gel; Products; Nanoparticles; Letters ;  
Decomposition; Roasting; Calcination

**Subj Catg:** 14, Raw Materials

7/8/1306 (Item 3 from file: 335)

Ceramic Abstracts/World Ceramics Abstracts

(c) 2009 CSA. All rights reserved.

0000355426 IP Accession No: 84-05036

**Preparation and Photoluminescence of Europium-Doped Titania Nanocrystals**

**Publication Date: 2004**

**Descriptors:** Titanium dioxide; Nanocrystals; Europium; Doped crystals; Photoluminescence  
; Excitation spectra; Anatase; Sol-gel **processes**; Crystal structure

**Subj Catg:** 16B, Physical Properties

7/8/1307 (Item 4 from file: 335)

Ceramic Abstracts/World Ceramics Abstracts

(c) 2009 CSA. All rights reserved.

0000348424 IP Accession No: 83-02289A

**SYNTHESISING AND COMPARING THE PHOTOCATALYTIC PROPERTIES OF HIGH SURFACE AREA RUTILE AND ANATASE TITANIA NANOPARTICLES**

**Publication Date: 2003**

**Descriptors:** Titania; Rutile and anatase nanopowders with high surface area; Decomposition  
reaction of nanopowders with phenol; Nanoparticles; Powders; Decomposition reaction of  
tio2 nanopowders with phenol; Preparation; Photocatalytic properties; Morphology; Thermal

## Appendix A-5. Irrelevant Titles

analysis; Active site; Amorphous phase; Anatase; Aqueous solution; Calcination; Calcination temperature; Calcined powder; Cation; Chemical reaction; Crystalline; Crystalline phase; Crystallisation; Crystallite; Crystallite size; Decomposition; Degradation; Fine particle; Hydrolysis; Hydroxy group; Ion; Ionic site; Microstructure; Nanocrystalline; Nanocrystalline material; Nanoparticle; Nanosize; Particle; Particle morphology; Particle size; Phase ; Phase composition; Phenol; Photoactivity; Photocatalyst; Photocatalytic activity; Photodegradation; Pore size distribution; Powder; Powder morphology; Powder preparation; **Processing**; Raw material; Reaction; Rutile; Specific surface area; Surface analysis; Surface area; Synthesis; Technical; Thermal **processing**; Titanium chloride; Titanium dioxide; Titanium ion; Titanium tetrachloride

**Subj Catg:** 15A, Oxides

7/8/1308 (Item 5 from file: 335)

Ceramic Abstracts/World Ceramics Abstracts

(c) 2009 CSA. All rights reserved.

0000335345 IP Accession No: 81-06899A

### **PHOTOCATALYTIC CHARACTERISTICS OF NANOMETRE-SIZED TITANIA POWDERS FABRICATED BY A HOMOGENEOUS-PRECIPITATION PROCESS**

**Publication Date:** 2002

**Descriptors:** Titania; Nanopowders prepared by homogeneous precipitation; Powders; Tio<sub>2</sub> nanopowders prepared by homogeneous precipitation; Nanoparticles; Preparation; Tio<sub>2</sub> nanopowders by homogeneous precipitation; Precipitation; Homogeneous precipitation of tio<sub>2</sub> nanopowders; Photocatalysts; Photocatalytic properties; Removal of pb and cu ions from aqueous edta solution by tio<sub>2</sub> powder; Adsorption; Aqueous solution; Chemical preparation ; Chemical **processing**; Commercial material

**Subj Catg:** 15A, Oxides

7/8/1309 (Item 6 from file: 335)

Ceramic Abstracts/World Ceramics Abstracts

(c) 2009 CSA. All rights reserved.

0000334644 IP Accession No: 81-06879A

### **NANOPOROUS TITANIA SYNTHESISED BY A NANOSCALE CASTING PROCESS IN SUPERCRITICAL CARBON DIOXIDE**

**Publication Date:** 2002

**Descriptors:** Titania; **Processing** of nanoporous material by templating; Morphology ; Nanoporous titania **processed** by templating; Porous ceramics; **Processing** of titania by templating; Activated carbon; Adsorption isotherm; Anatase; Calcination temperature; Carbon dioxide

**Subj Catg:** 15A, Oxides

7/8/1310 (Item 7 from file: 335)

Ceramic Abstracts/World Ceramics Abstracts

(c) 2009 CSA. All rights reserved.

## Appendix A-5. Irrelevant Titles

0000325336 IP Accession No: 81-04199A

### **NANOCRYSTALLINE IRON-DOPED MESOPOROUS TITANIA AND ITS PHASE TRANSITION**

**Publication Date:** 2001

**Descriptors:** Nanocrystalline materials; Sol-gel derived fe-doped mesoporous tio2; Titania; Sol-gel derived nanocrystalline fe-doped mesoporous tio2; Porous materials; Preparation; Nanocrystalline fe-doped mesoporous tio2 by novel sol-gel route; Sol-gel **process**; Nanocrystalline fe-doped mesoporous tio2 prepared by novel route; Phase transitions; Crystallisation; Particle growth; Nanoparticles; Absorption spectra; Additive; Analysis; Calcination; Calcination temperature

**Subj Catg:** 15A, Oxides

7/8/1312 (Item 2 from file: 636)

Gale Group Newsletter DB(TM)

(c) 2010 Gale/Cengage. All rights reserved.

06336763 **Supplier Number:** 149460737 (USE FORMAT 7 FOR FULLTEXT)

**Titanium dioxide nanoparticles may affect mice brain cells.(NANOTECHNOLOGY)**

August , 2006

**Word Count:** 275

**Publisher Name:** International Newsletters

**Descriptors:** \*Cell research; Nanotechnology; Titanium dioxide; Skin care products; Nanoparticles; Toiletries industry

**Product Names:** \*2834642 (Skin Care Cream)

**Industry Names:** CHEM (Chemicals, plastics and rubber industries); ENG (Engineering and manufacturing industries )

**SIC Codes:** 2834 (Pharmaceutical preparations); 2844 (Toilet preparations )

**NAICS Codes:** 325412 (Pharmaceutical Preparation **Manufacturing** )





Office of Research  
and Development (8101R)  
Washington, DC 20460

Official Business  
Penalty for Private Use  
\$300

EPA/600/R-10/089  
August 2010  
[www.epa.gov](http://www.epa.gov)

Please make all necessary changes on the below label,  
detach or copy, and return to the address in the upper  
left-hand corner.

If you do not wish to receive these reports CHECK HERE ;  
detach, or copy this cover, and return to the address in the  
upper left-hand corner.

PRESORTED STANDARD  
POSTAGE & FEES PAID  
EPA PERMIT No. G-35



**Recycled/Recyclable**

Printed with vegetable-based ink on  
paper that contains a minimum of  
50% post-consumer fiber content  
processed chlorine free