

**Appendix A**  
**IDX Technologies Summary Test Report**

**NOTE: This document was prepared by IDX Technologies and is published as received. This document was not edited or verified by Battelle.**



March 22 2006

# ETV REPORT

## IDX-Technologies

### 1. Introduction

As we have reported in many occasions in the world that we have succeeded in the development of RIMMPA (Resonance Ionization with the Multi-Mirror system Photon Accumulation)-TOFMS. By the development of it, we have achieved the 2 color 2 photon resonance ionization of tetra to octa chlorinated DDs and DFs with selective soft ionization of PCDD's and PCDF's isomers.

Thus, the ETV for us is to verify the technical results on RIMMPA-TOFMS. We have adopted two countermeasures upon this current situation. The first countermeasure is to adopt an accumulation tube as a condenser for obtaining the high density sample gas and to use helium gas for desorbing it as carrier gas. The second is to adopt the fixed wavelength laser to make the size compact and to realize easy operation and mobile-ability.

What we had achieved in the laboratory was to detect the PCDD's and PCDF's isomers of 2,3,4,7,8-PeCDF at 410 ppq sensitivity by changing the excitation wavelength and could detect only objective parent ion without any fragmentation.

We haven't reached, however, the stage to detect the PCDD's and PCDF's isomers in the real gas. This is one of the purposes of this ETV tests for us to establish the method and verify the on-site and rapid analysis method in the real gas from boiler.

### 2. Target

What we have targeted through ETV test this time was that after filtering, adsorbing and accumulating the exhausting gas into a TENAX column, desorption of PCDD's and PCDF's are carried under the specifically controlled temperature and then is loaded to RIMMPA-TOFMS with helium carrier gas. We aimed at the two kinds of analysis, one was the Congener analysis and the other was the Isomer analysis.

Here, we mean that the congeners analysis is to calculate the TEQ from the relation between the sum of the total ion signals of tetra to octa chlorinated DDs and DFs and that of the Method 23(M23). The sum of the total ion signals of tetra to octa chlorinated DDs and

DFs congener's ion is calculated as follows. Selecting and fixing an appropriate wavelength of excitation laser wavelength as 310.99nm, we can get all the tetra to octa chlorinated DDs and DFs congener's ion signals and sum up the amount of time variation.

And the isomer analysis is to calculate the TEQ from the correlation between the total amount of target isomer's ion signal and that of M23 signals. Setting the excitation laser wavelength for the target isomer and getting the isomer signal and integrating it by time, we can get the total amount of target isomers.

### **3. Test circumstances**

Terms: Sep. 12 2005 to Sep. 22 2005

Place: U.S. Environmental Protection Agency, Research Triangle Park

Test facilities: A 2.94 MBtu/hr, 3-Pass Wetback Scotch Marine Package Boiler manufactured by Superior Boiler Works, Inc.,

(Details are in the ETV program report)

### **4. Test method**

The schematic diagram of sampling is shown in Fig.1

The sampling steps are briefly divided into next four steps.

#### **4.1 Adsorption**

The exhausted gas flows in the Adsorption and Heat Desorption (AHD) unit from sampling port in flue gas duct heated at 160 degree C through sampling probe heated at 200 degree C, glass fiber filter and 5m heated sampling line (Teflon tube). At the AHD, PCDD's and PCDF's in the exhausted gas are adsorbed in the 105 degree C heated TENAX column. The exhausted gas is disposed lastly in APCS (Air Pollutant Control System) through Silica gel, NaOH solution and pump.

#### **4.2 Helium Substitution**

To remove nitrogen, oxygen and low boiling point organic compounds that remain in TENAX column, helium gas of 120 degree C is substituted for the gases in TENAX column of 105 degree C for 5 minutes with 3L/min.

#### **4.3 Desorption**

The column is heated up to 300 degree C after closing the entrance and exit of it. Keeping it for 10 minutes after the temperature rises up to 300 degree C, the objective gas in helium carrier gas is injected to RIMMPA-TOFMS at 200 degree C.

#### **4.4 Analysis**

Analysis of congeners and isomers by RIMMPA-TOFMS are carried out.

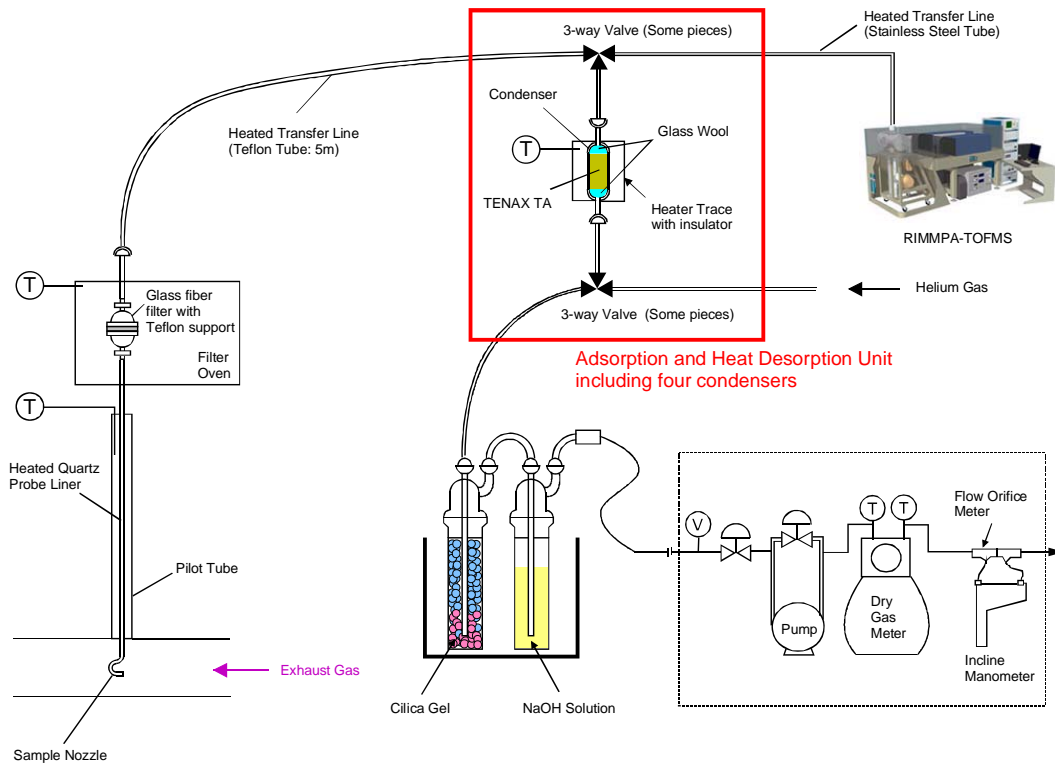

Fig.1 Schematic diagram of the sampling train, adsorption and heat desorption unit, and measurement by RIMMPA-TOFMS

## 5. Test conditions

Chart 1 shows the test conditions of each day during ETV tests.

Chart 1

Test Number	Sampling			DXN-Desorption		Excitation Laser		Ionization Laser
	time [min]	rate [L/min]	volume [L]	temp. [deg.C]	flow rate [L/min]	Energy [mJ]	Wavelength [nm]	Energy [mJ]
9/12	240	2.739	657.36	300	1	3	310.99	0.1
9/14	90	4.85	436.5	280	1	3	310.99	0.1
9/16-#1	70	17.083	1195.81	300	1	3	310.99	0.1
9/16-#2	90	16.562	1490.58	300	1	3	310.99	0.1
9/19	240	15.19	3645.6	300	1	3	315.83	0.1
9/20-#1	120	13.76	1651.2	300	0.5	3	310.19	0.5
9/20-#2	240	12.51	3002.4	300	0.5	3	310.19	0.5
9/21-#1	120	17.19	2062.8	300	0.5	3	310.19	0.5
9/21-#2	200	19.3	3860	300	0.5	3	310.19	0.5
9/22-#1	15	16.19	242.85	300	0.5	3	310.19	0.5
9/22-#2	15	16.33	244.95	200-300	0.5	3	310.19	0.5

## 6. Test results

### 6.1 Congener Analysis Test Results

Chart 2 is the results of our ETV tests. The Test Number 9/19 is the result of isomer analysis and the other all are congener analysis. The values in the chart show the signal strengths of the dioxin congeners that RIMMPA-TOFMS detected. Although RIMMPA-TOFMS has succeeded in congener identification of several high-chlorinated dioxins, RIMMPA-TOFMS has not succeeded in determination of isomers due to the bad influence of impurities that exist close to dioxins in mass numbers.

Chart 2

	9/12	9/14	9/16-#1	9/16-#2	9/19	9/20-#1	9/20-#2	9/21-#1	9/21-#2	9/22-#1	9/22-#2
TeCDD						7.1		12.1			
PeCDD						6.1		5.1			
HxCDD											
HpCDD											
OCDD											
TeCDF	1.7										
PeCDF											
HxCDF											
HpCDF											
OCDF	1.3										

Blank=Not identified

## 6.2 Test result details

### First half

The chart 3 below shows the results from Sep. 12 to Sep. 16.

Chart 3

	9/12	9/13	9/14	9/15	9/16
Sample transfer	5m Teflon tube		5m Teflon tube		5m Teflon tube
Adsorption	105 degree C	Pipe cleaning by solvent	105 degree C	Brand new pipe TENAX cleaning	105 degree C
Helium substitution	3L/min, 5min	AHD unit cleaning	3L/min, 5min	change of glass wool	3L/min, 5min
Desorption	300 degree C		300 degree C	Improvement sampling unit	300 degree C
RIMMPA- TOFMS	310.99nm, 3mJ 213nm, 0.1mJ	New HTPD	310.99nm, 3mJ 213nm, 0.1mJ	Cleaning and change HTPD	310.99nm, 3mJ 213nm, 0.1mJ
Others	Preheating of He gas 200 degree C  Congener analysis		preheating of He gas 200 degreeC  Congener analysis		New He bomb Insert activate charcoal between TENAX column and He bonbe  No preheating of He gas Congener analysis
Results	Fig.2-12 Lots of impurity TENAX decomposition Impossible to identify and determine	Abherence of TENAX in inside of HTPD  Adherence of TENAX in the pipe	Fig13 same as 9/12  Fig14, 15 stains in the AHD unit	Higher volume of sampling rate by changing glass wool	Fig17, 18 spectrum quenching of m/z320, 345  No changes in the others  Change from Helium to N <sub>2</sub> for cleaning  Chamber baking

**Sep. 12 2005**

Figure 2 (Test number: 9/12) shows the mass spectrum of 270 to 500 measured by RIMMPA-TOFMS. The ion signal was obtained by integrated value of 3 minutes measurement. Although we recognized the PCDD's and PCDF's peaks, it was tough to identify and determine PCDD's and PCDF's because the spectra of other impurities overlapped the peak signals of the PCDD's and PCDF's. As indicated a and b in Fig.2, we detected the spectrum of impurities that adhere to the TENAX, the mass number of which increase by m/z 75 regularly, and the spectrum obstruct the measurements of PCDD's and PCDF's. It was thought as impurity in TENAX and it disturbs the PCDD's and PCDF's spectra.

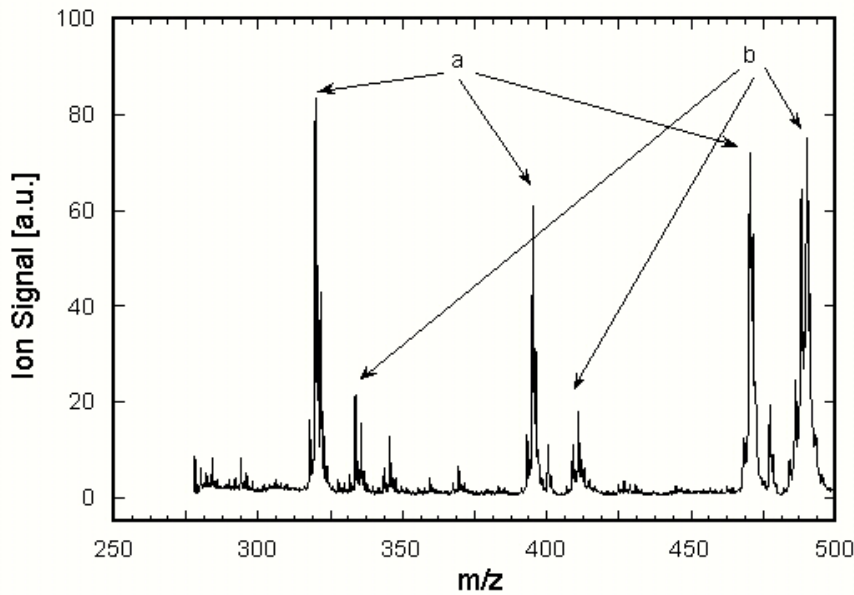

Fig.2 Mass spectrum (Test number: 9/12)

Figures 3 to 12 are the mass spectra which are expanded near PCDD's and PCDF's congeners. The indicated values are relative intensity of each peak normalized by M+2 ion signal in the case of TeCDF or M+4 ion signal in the case of OCDF. We recognized some differences in the intensity ratio between the observed one and that estimated from existence ratio of chlorine isotope. In the case of TeCDF, the observed ratios are 50.6/100 and 60.5/100, while the estimated ratios are 76/100 and 49/100. We assume that these differences might be caused by the spectra overlapping.

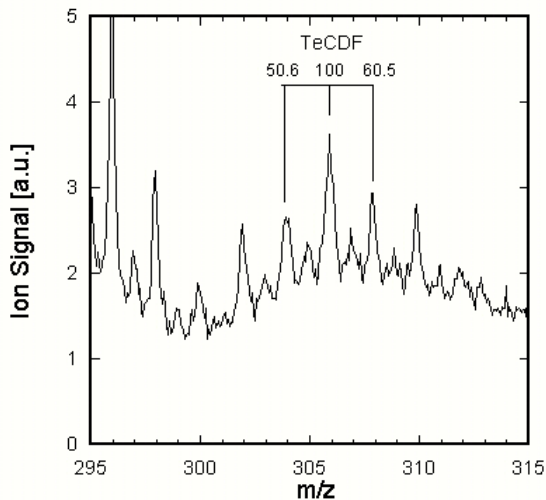

Fig.3 TeCDF

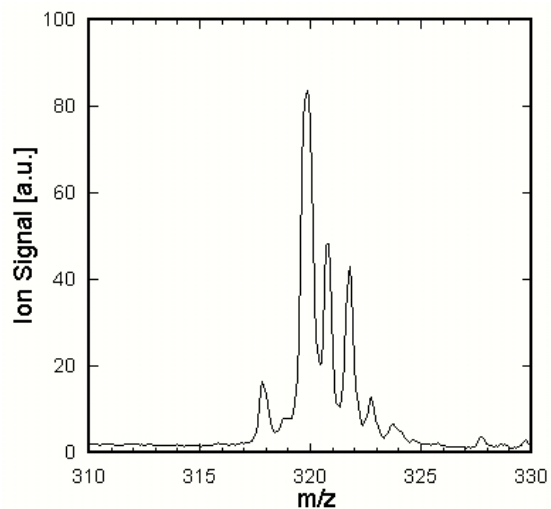

Fig.4 TeCDD

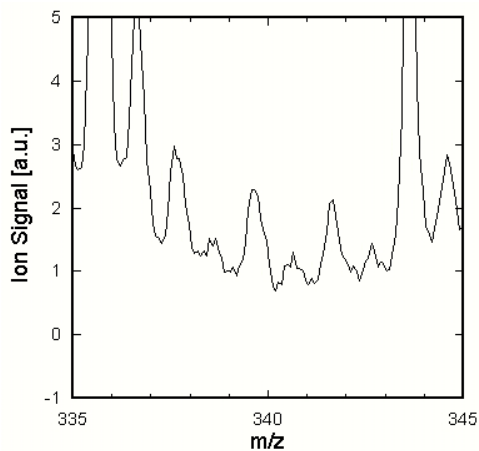

Fig.5 PeCDF

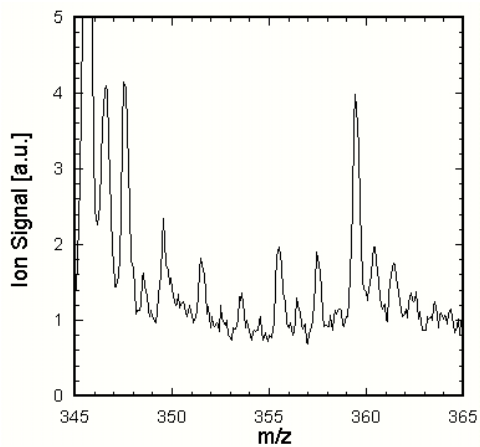

Fig.6 PeCDD

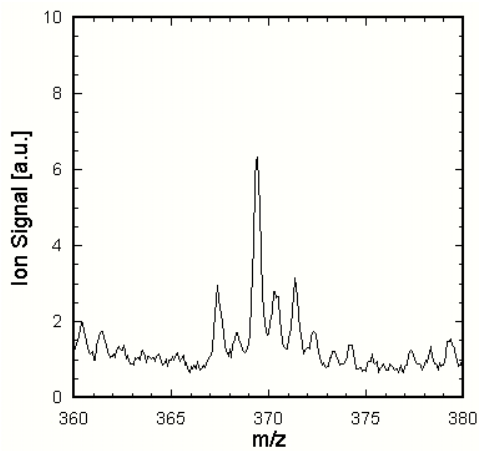

Fig.7 HxCDF

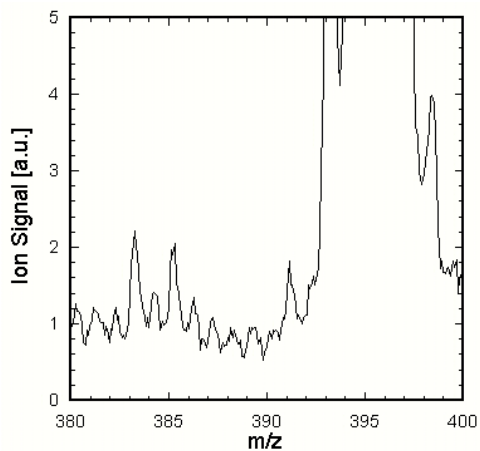

Fig.8 HxCDD

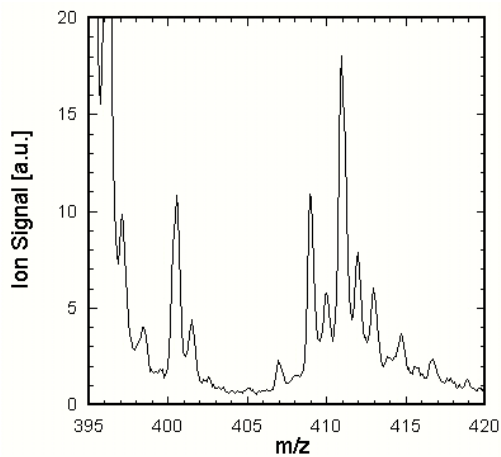

Fig.9 HpCDF

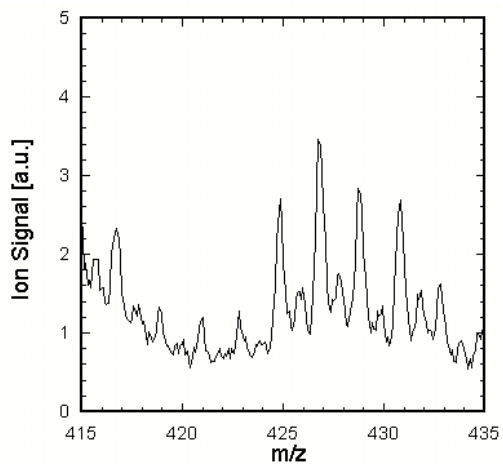

Fig.10 HpCDD

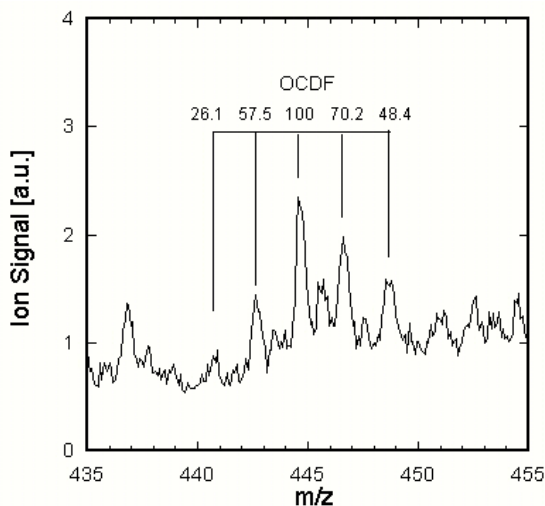

Fig.11 OCDF

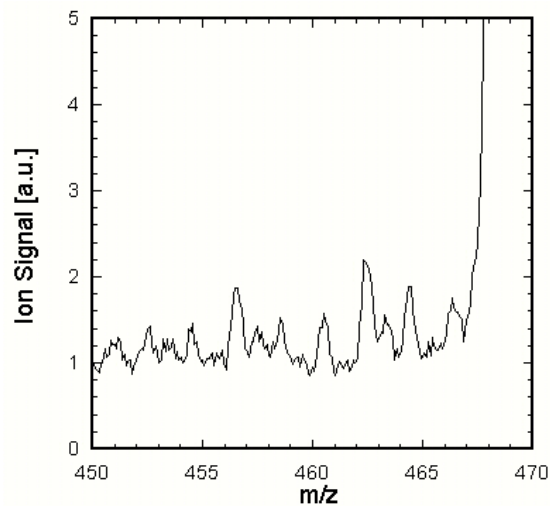

Fig.12 OCDD

**Sep. 13 2005**

To avoid the stains in the AHD unit, pipes and High Temperature Pulsed gas Device (HTPD), HTPD was changed to new one. We blow off TENAX in the AHD unit by the compressed air. And we also cleaned pipes between the AHD unit by both of compressed air and solvent.

**Sep. 14 2005**

Figure 13 is the mass spectrum (mass number: 270 to 500) measured by RIMMPA-TOFMS. The ion signals are obtained by integrated value of 3 minutes measurement. The signals of impurity, however, did not disappear even after cleaning and changing of HTPD to new one. It was tough to identify and determine PCDD's and PCDF's because the spectra of the other impurity overlapped the peak signal of the PCDD's and PCDF's although we recognized the PCDD's and PCDF's peaks in our results.

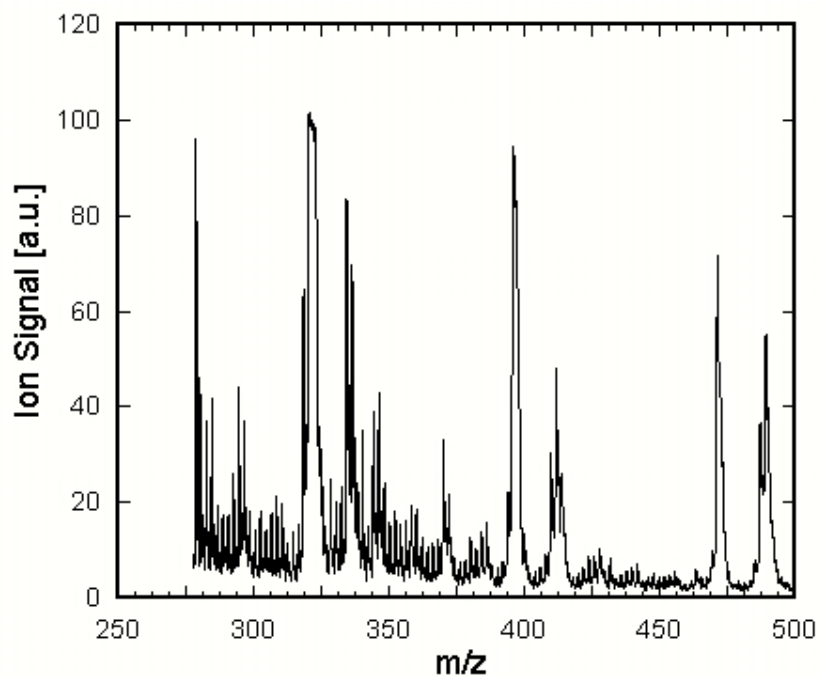

Fig.13 Mass spectrum (Test number: 9/14)

Figure 14 and 15 show the two cases of helium gas pass through the AHD unit and the case of not passes through the unit. From these results, we realized that the inside of the AHD unit has stained, so that we newly created another way of sampling without using the unit. (Refer Fig.16). And we cleaned HTPD and changed the parts of the units. Also we cleaned TENAX as well at 280 degree C for 16 hours assuming that TENAX itself has its stain.

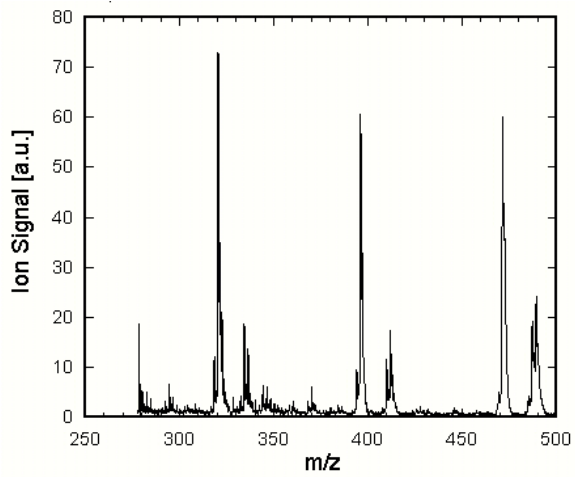

Fig.14 through the AHD unit

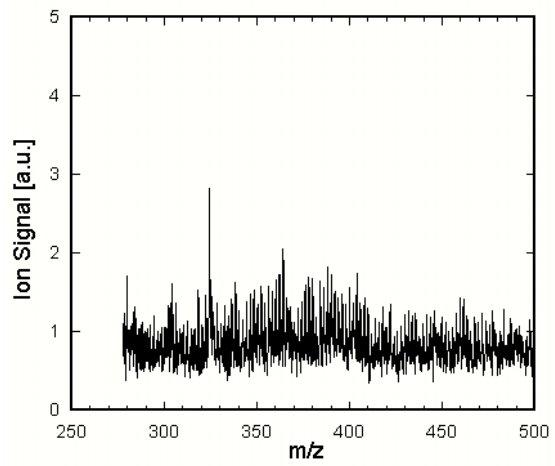

Fig.15 not going through the AHD unit

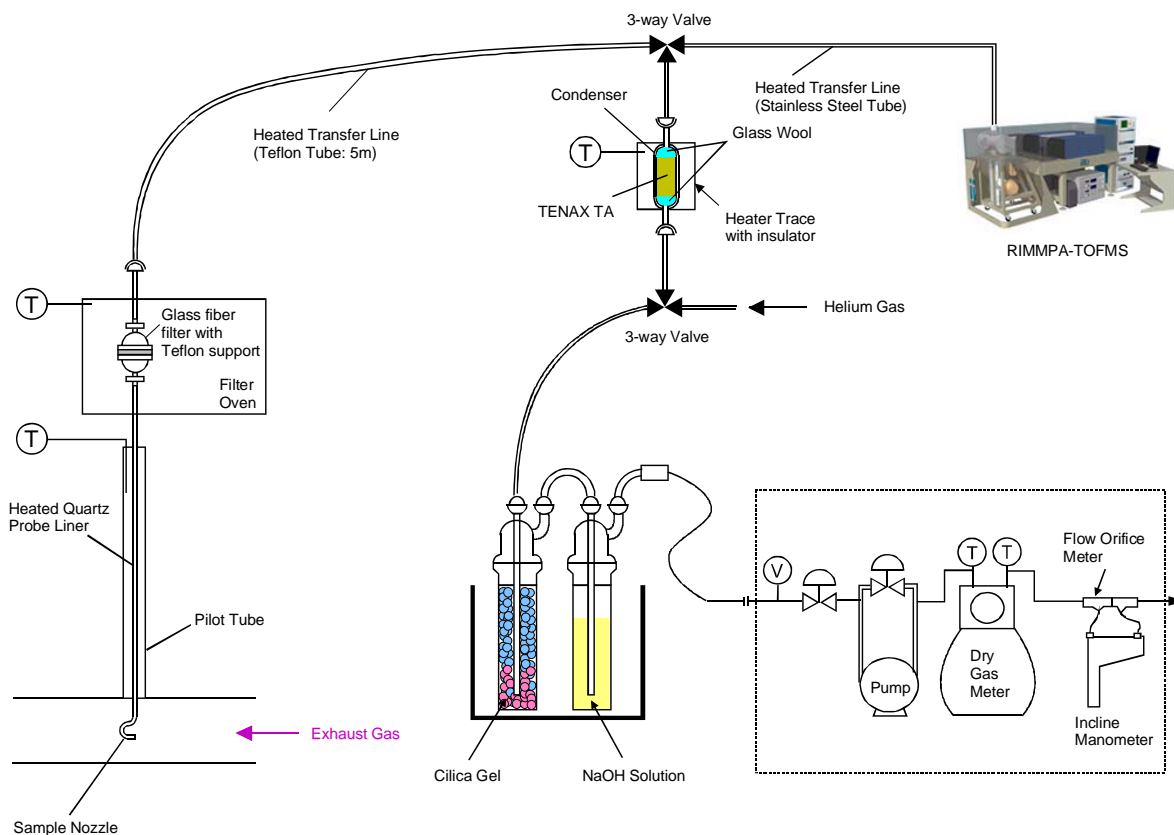

Fig.16 Schematic diagram of the sampling train, adsorption and heat desorption by single condenser, and measurement by RIMMPA-TOFMS

**Sep. 16 2005**

We changed the glass wool to raise the sampling rate, and changed a helium cylinder to a new one as well. And we inserted the activated charcoal filter between helium cylinder and TENAX column to avoid impurity in the helium gas.

Figure 17(Test number: 9/16-#1), Fig.18 (Test number: 9/16-#2) are the mass spectra (mass number: 270 to 500) measured by RIMMPA-TOFMS and the mass spectra are obtained by integrated value of 3 minutes measurement. If we compare with the Fig.14, the ion signal of mass number 320 and 345 are decreased. However, we could not identify and determine the PCDD's and PCDF's due to the peaks of impurity.

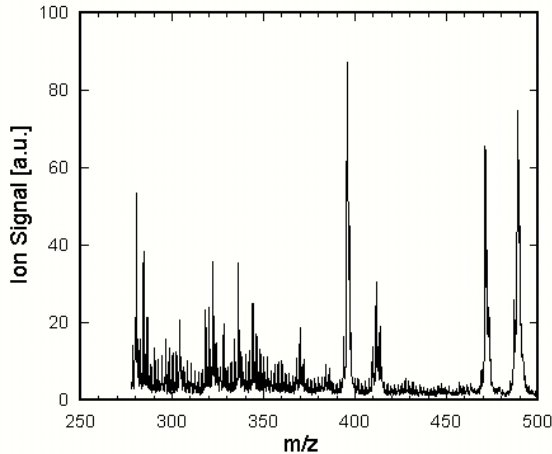

Fig.17 Mass spectrum(Test number:9/16-#1)

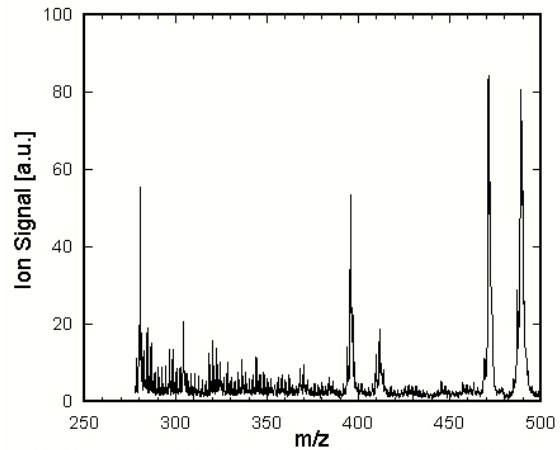

Fig.18 Mass spectrum(Test number: 9/16-#2)

We changed the cleaning solvents from helium to nitrogen and cleaned HTPD again at 200 degree C for a day. Baking in the chamber was also done for a day. Another way that we did was to change to a 3/4 inch tube that doesn't require seal tape because we assumed that the exhausted gas from seal tape might cause the noise in the spectra of PCDD's and PCDF's.

## Second half

The chart 4 below shows the summary of the results of sep. 19 thru Sep.22

Chart 4

	9/19	9/20	9/21	9/22
Sample transfer	5m Teflon tube	5m Teflon tube	No use	No use
Adsorption	105 degree C	105 degree C	105 degree C	105 degree C
Helium substitution	3L/min, 5min	3L/min, 5min	3L/min, 5min	3L/min, 5min
Desorption	300 degree C	300 degree C	300 degree C	300 degree C
RIMMPA- TOFMS	315.83nm, 3mJ 213nm, 0.1mJ	310.19nm, 3mJ 213nm, 0.5mJ Change to improve the sensitivity	310.19nm, 3mJ 213nm, 0.5mJ	310.19nm, 3mJ 213nm, 0.5mJ
Others	No preheating of He gas Isomer analysis (2,3,4,7,8-PeCDF) Change the 3/4 inch tube	No preheating of He gas Leak check of sampling line Doubled the volume the second sampling of first volume Congener analysis	No preheating of He gas Congener analysis Set TENAX column directly after the filter	No preheating of He gas Congener analysis Set TENAX column directly after the filter
Results	Fig.19 Spectrum quenching of m/z395, 410 Spectrum decreasing of m/z470, 490 Fig.20 Detect the peak signals in the m/z=338,340 and 342 2,3,4,7,8-PeCDF isomer is impossible to identify	Fig.21-32 TeCDD, PeCDD is possible to identify No detection of HpCDD, OCDF,OCDD Other congeners are impossible to identify	Fig.34-45 Same as previous day There is a possibility TENAX was broken through due to the too much sampling amount	Fig.46-56 m/z278 signal increased Congeners are impossible to identify Detection of mass spectrum m/z260, 262 Fig.57 The flow rate 0.5 to 3 L/min the ion signals increased

### Sep.19 2005

Though many kinds of material are ionized because we use the shorter wavelength of the excitation laser in the congener analysis, the only selected isomers would be ionized in the isomer analysis because the longer wavelength of excitation laser is applied.

Figure 19 (Test number: 9/19) is the mass spectrum (mass number: 270 to 500) when we carried out the isomer analysis of 2,3,4,7,8-PeCDF. The ion signal is integrated value for 3 minutes measurement. The peak signals of mass number 395, 410 quenched, 470 and 490 decreased and peak signal of mass number 362 was increased. These materials are resonantly ionized by the excitation laser wavelength of 2,3,4,7,8-PeCDF.

Figure 20 is the mass spectrum near the 2,3,4,7,8-PeCDF. Although there exist the peak signals in the m/z=338, 340 and 342, we could not identify the 2,3,4,7,8-PeCDF isomer because the ionization intensity is different from the ionization intensity ratio that can be estimated by the isotope existence ratio.

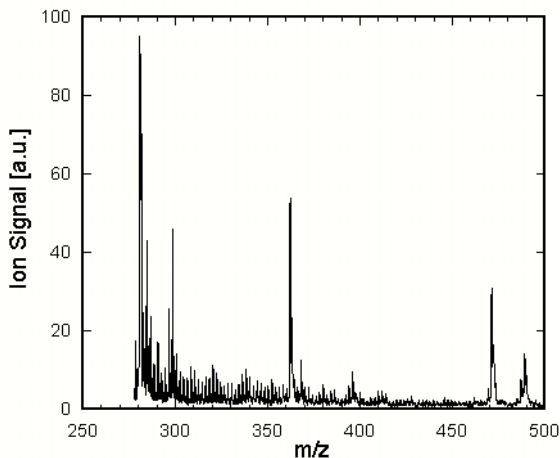

Fig.19 Mass spectrum (Test number: 9/19)

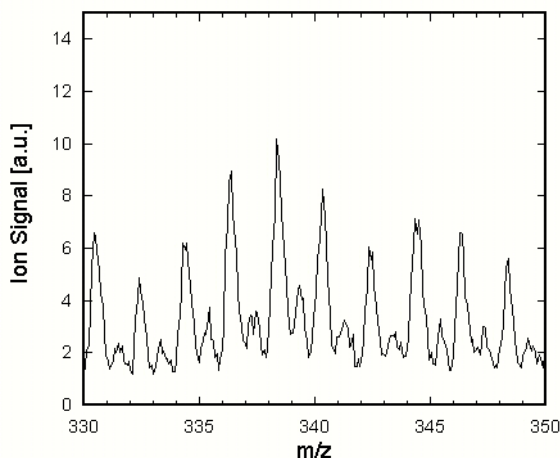

Fig.20 2,3,4,7,8-PeCDF

**Sep.20 2005**

We changed from isomer analysis to congener analysis because we could not identify 2,3,4,7,8-PeCDF in isomer analysis. We did leak check of sampling port before tests. To rise up the sensitivity, we changed the excitation laser wavelength to 310.19nm and ionization laser energy to 0.5 mJ because we thought the PCDD's and PCDF's density was too low to detect. We tested whether the peak signals become doubled when we sample the double volume as first sampling volume.

Figure 21 (Test number: 9/20-#1), Fig.22 (Test number: 9/20-#2) are the mass spectra (mass number: 270 to 500) measured by RIMMPA-TOFMS and the mass spectra are obtained by integrated value of 3 minutes measurement. The second sampling volume was double of the first one, however, the signals in the second sampling were lower than the first one.

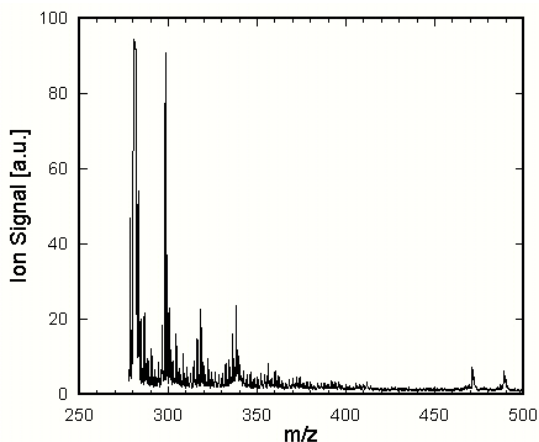

Fig.21 Mass spectrum (Test number:9/20-#1)

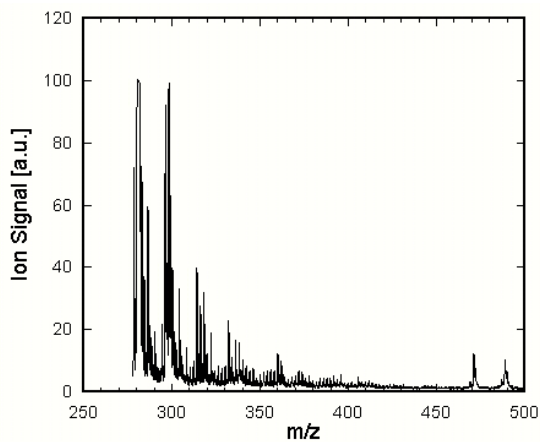

Fig.22 Mass spectrum (Test number:9/20-#2)

Figures 23 to 32 are the mass spectra which are expanded the near parent-ion spectrum of the tetra to octa chlorinated DDs and DFs. The indicated values are relative intensity of each peak normalized by M+2 ion signal in the case of TeCDD, PeCDD. We recognized some differences in the intensity ratio between the observed one and that estimated from existence ratio of chlorine isotope. In the case of TeCDD, the observed ratios are 71.2/100 and 57.6/100, while the estimated ratios are 77.4/100 and 48.7/100. But no detection was made on HpCDD, OCDF and OCDD or of the other congeners.

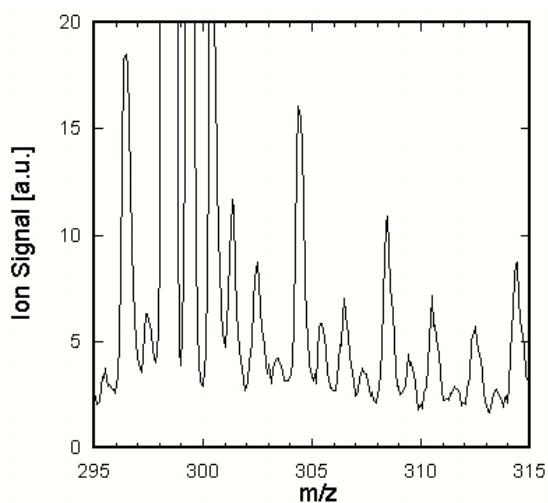

Fig.23 TeCDF

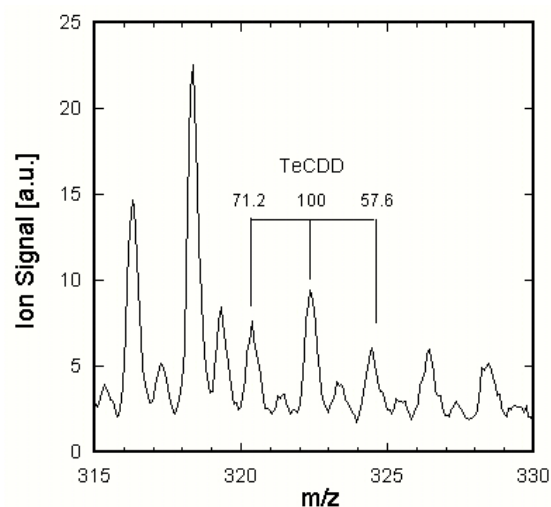

Fig.24 TeCDD

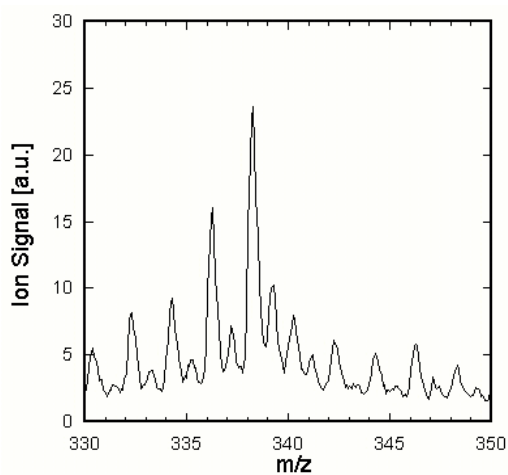

Fig.25 PeCDF

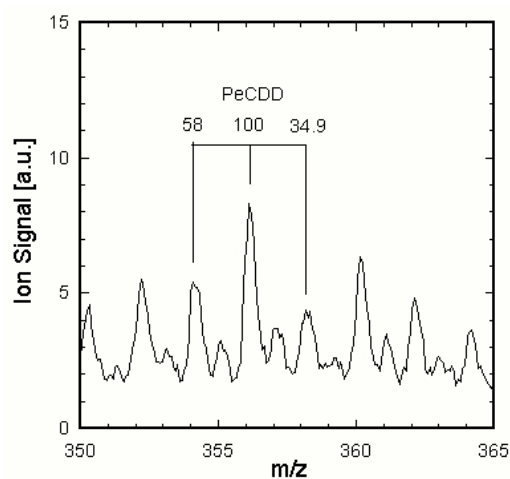

Fig.26 PeCDD

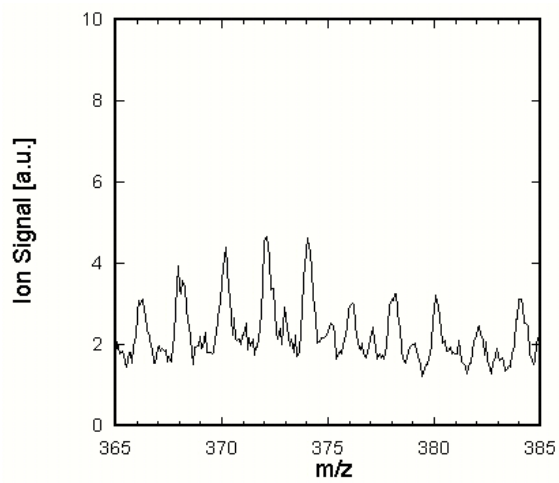

Fig.27 HxCDF

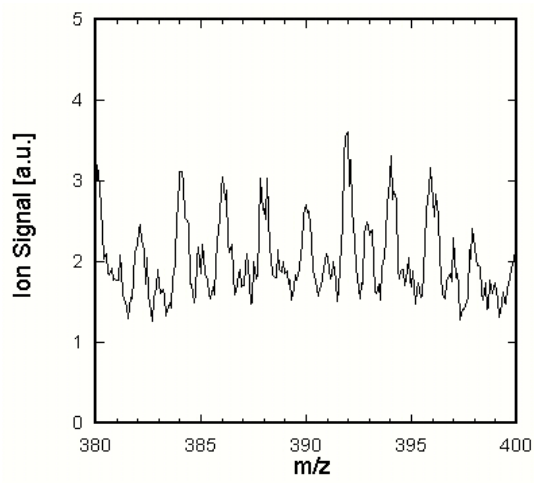

Fig.28 HxCDD

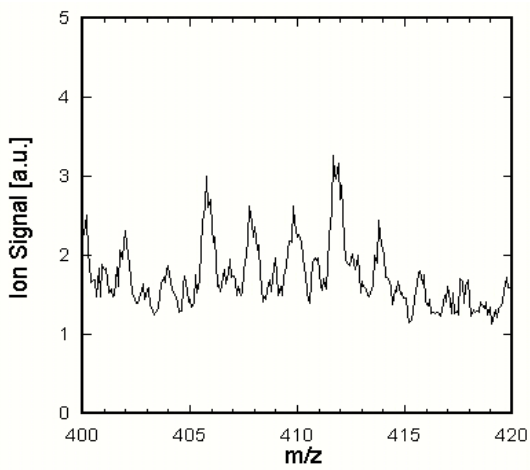

Fig.29 HpCDF

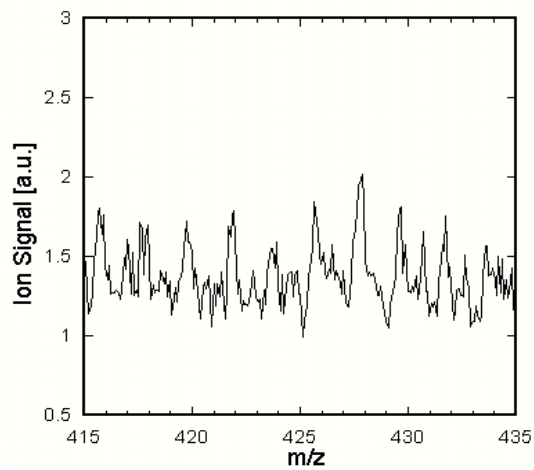

Fig.30 HpCDD

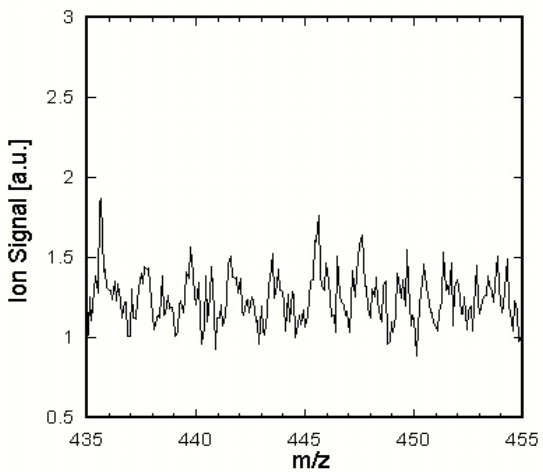

Fig.31 OCDF

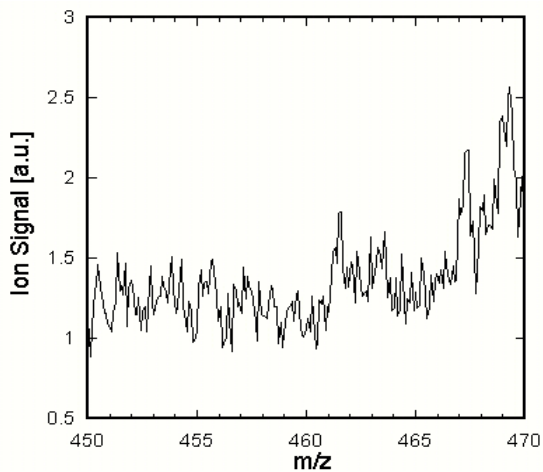

Fig.32 OCDD

**Sep.21 2005**

Knowing the fact that PCDD's and PCDF's are decreased to 1/2 during the gas moves 30cm in a 1/4 inch size Teflon tube, and that if a Teflon tube is heated at 200 degrees C, out gas will occur and PCDD's and PCDF's will be denatured, the 5m heated sampling line (Teflon tube) prepared before the experiment was removed. So the TENAX column was set directly after the filter of filter oven (Fig.33). After sampling, the temperature of the TENAX column was cooled down from 105 degree C and took it out from Filter Oven. And bringing it to the site of RIMMPA-TOFMS and going into the steps of helium substitution, desorption and analysis were carried out.

Figure 34 (Test number: 9/21-#1), Fig.35 (Test number: 9/21-#2) are the mass spectra (mass number: 270 to 500) measured by RIMMPA-TOFMS and the mass spectra are obtained by integrated value of 3 minutes measurement. The total trend of the results of no-use of Teflon tube was not different from the case of use of it. The second sampling volume was doubled as the previous day and the signals of impurity were decreased on this day. We decided it had break through since there are too many amounts of samplings.

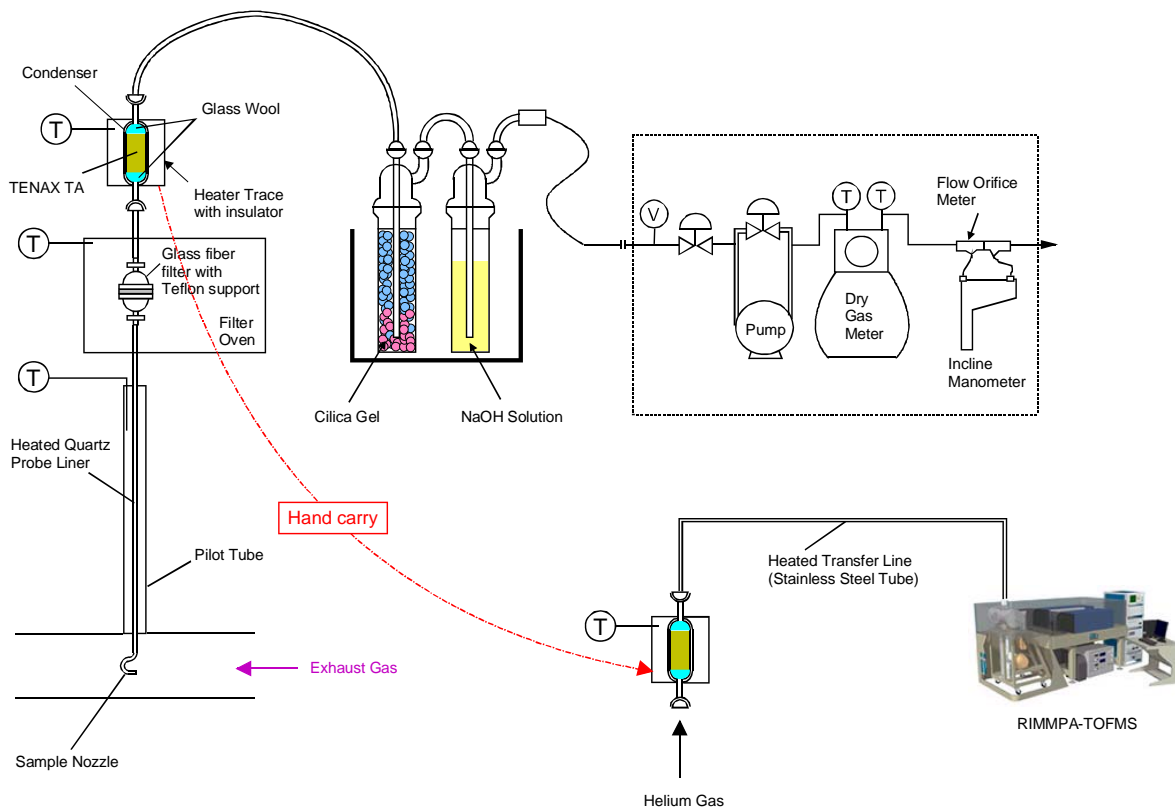

Fig.33 Schematic diagram of the sampling train, with single condenser, connected to filter directly, and measurement by RIMMPA-TOFMS

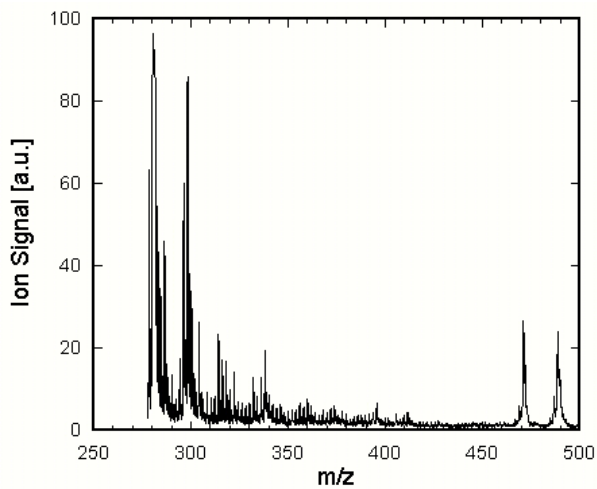

Fig.34 Mass spectrum (9/21-#1)

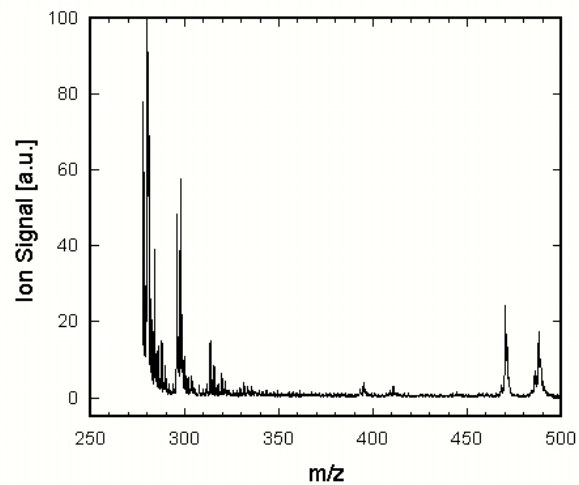

Fig.35 Mass spectrum (9/21-#2)

Figures 36 to 45 are the mass spectra which are expanded near parent-ion spectrum of the tetra to octa chlorinated DDs and DFs. The indicated values are relative intensity of each peak normalized by M+2 ion signal in the case of TeCDD, PeCDD. We recognized some differences in the intensity ratio between the observed one and that estimated from existence ratio of chlorine isotope. In the case of TeCDD the observed ratios are 67.2/100 and 38.8/100, while the estimated ratios are 77.4/100 and 48.7/100. But the other congeners were impossible to identify.

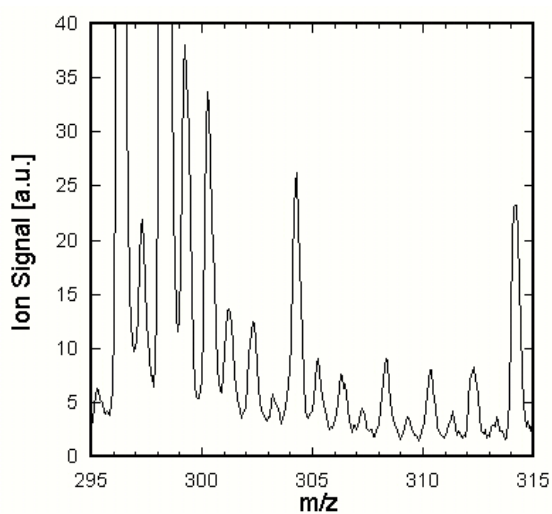

Fig.36 TeCDF

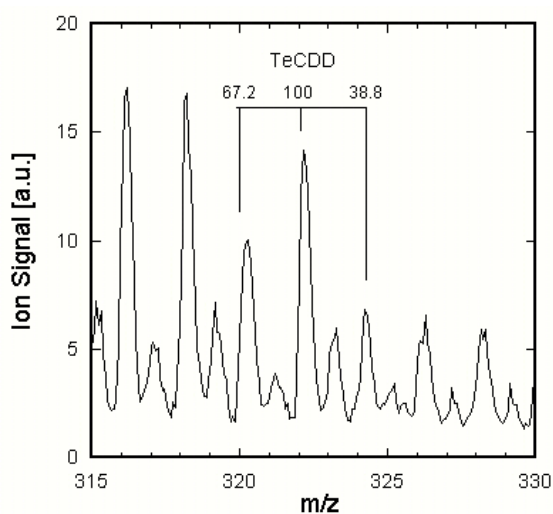

Fig.37 TeCDD

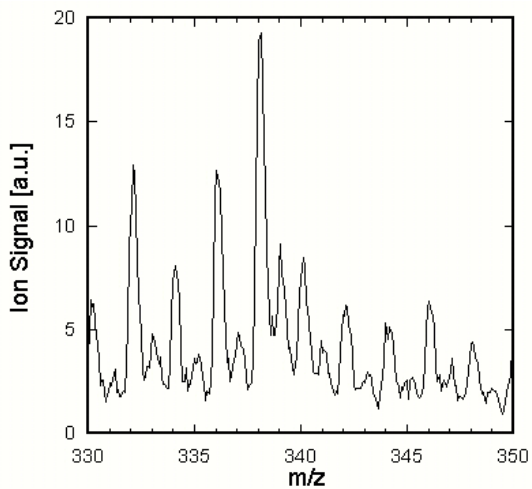

Fig.38 PeCDF

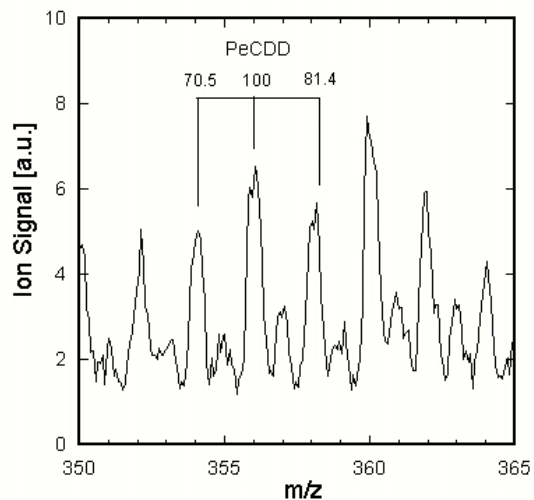

Fig.39 PeCDD

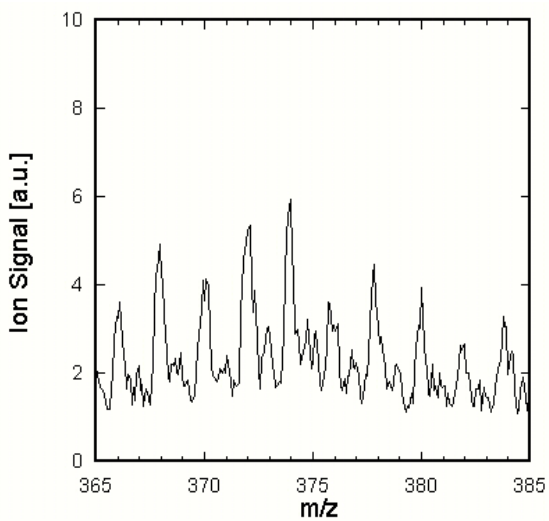

Fig.40 HxCDF

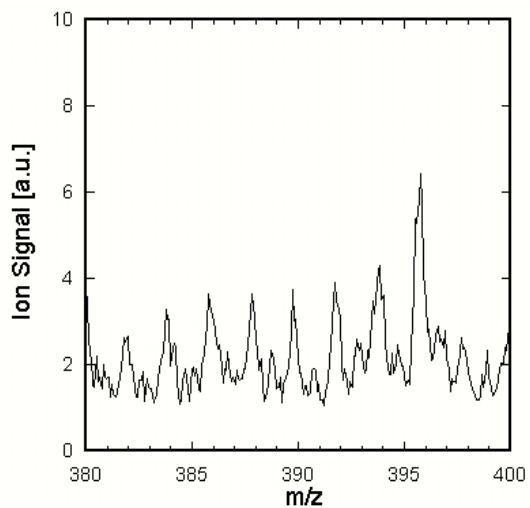

Fig.41 HxCDD

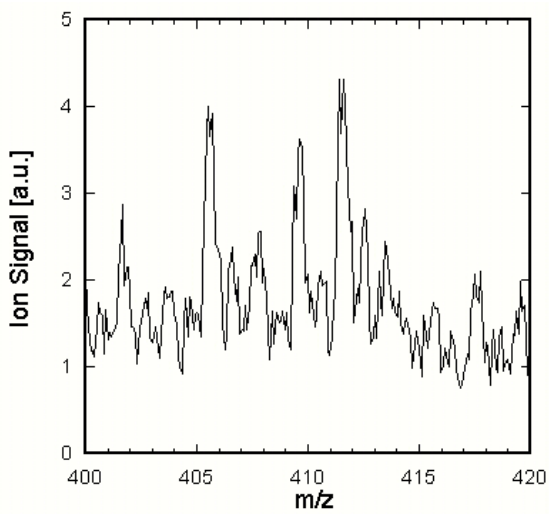

Fig.42 HpCDF

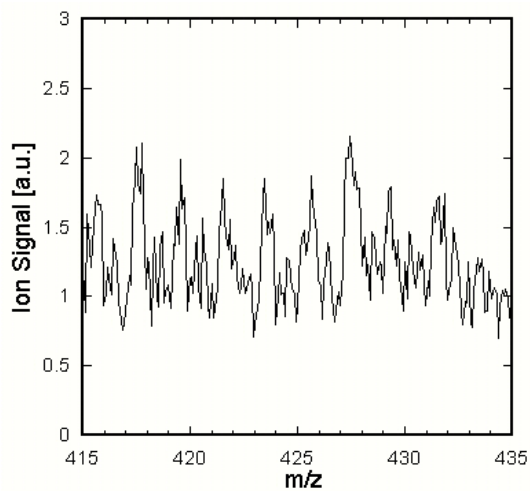

Fig.43 HpCDD

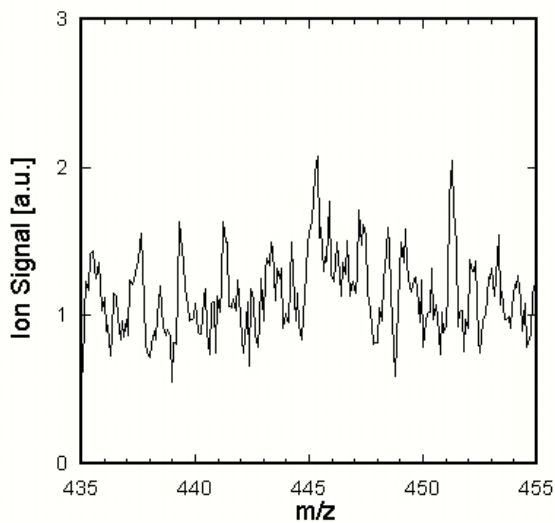

Fig.44 OCDF

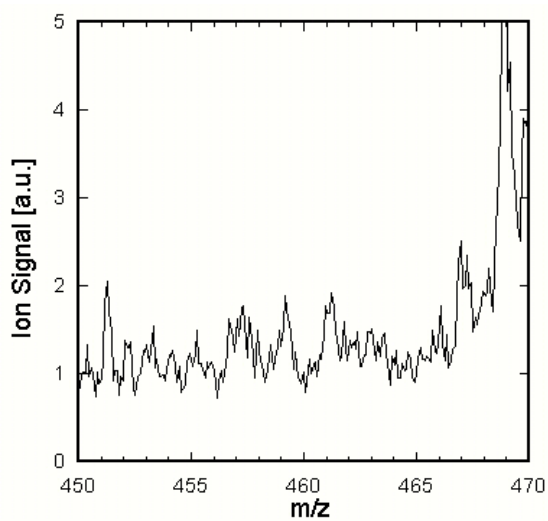

Fig. 45 OCDD

**Sep.22 2005**

To avoid the break through, we reduced the TENAX volume to 1 g and for the second sampling 2.5g and the volume of sampling itself were reduced.

Figure 46(Test number: 9/22-#1) is the mass spectrum (mass number: 270 to 500) measured by RIMMPA-TOFMS and the mass spectrum was obtained by integrated value of 3 minute measurements. Although the sampling volume was 1/8 of the previous day, the ion signals of mass number 278 and 280 were increased, and the other signals are decreased. We also measured the lower mass region from 250 to 270 and we recognized the spectra in mass number 260 and 262. It was assumed that the PAH or chlorinated PAH from boiler.

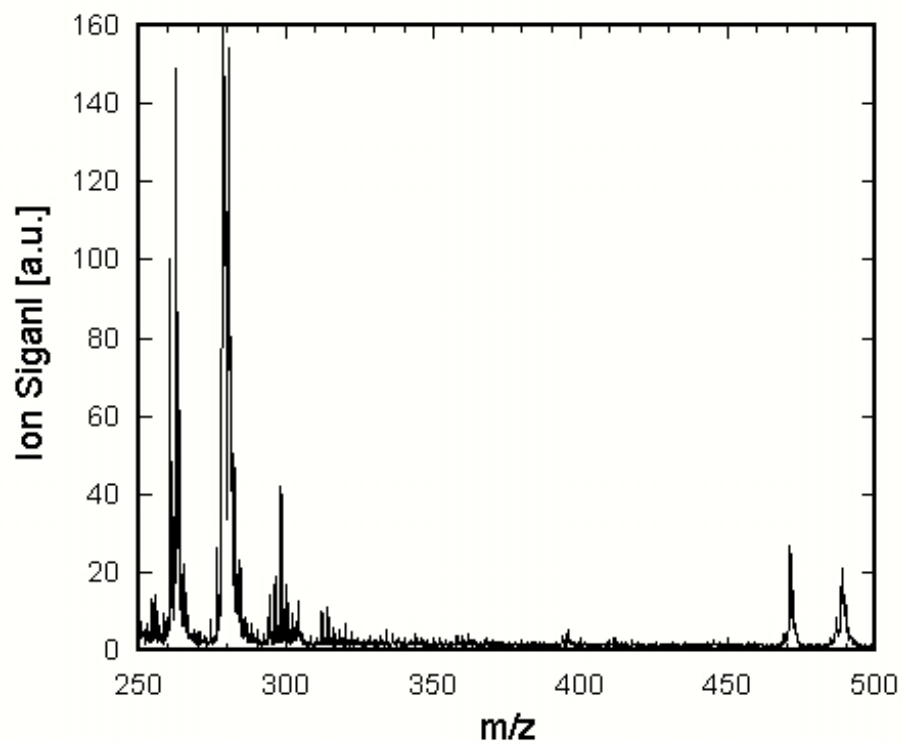

Fig.46 Mass spectrum (Test number:9/22-#1)

Figures 47 to 56 are the mass spectra which are expanded near parent-ion spectrum of the tetra to octa chlorinated DDs and DFs. The signals of impurity were decreased because the sampling volume was decreased and also the tetra to octa chlorinated DDs and DFs mass signals are decreased and we could not identify it nor determinate it.

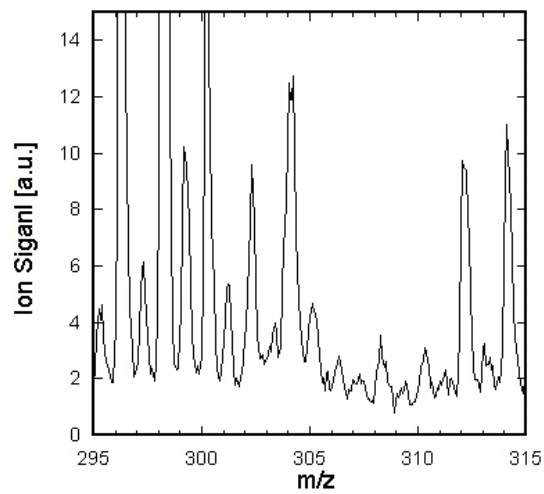

Fig.47 TeCDF

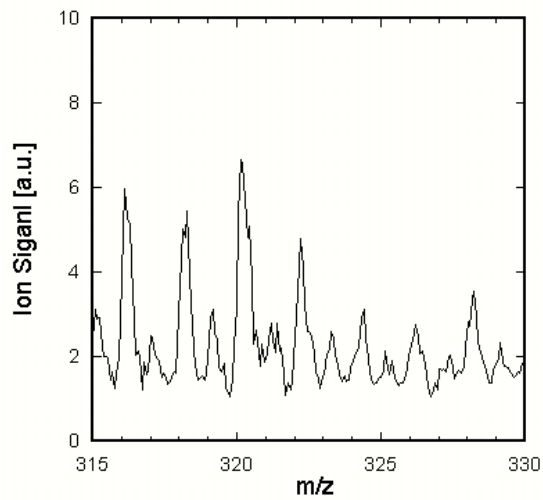

Fig.48 TeCDD

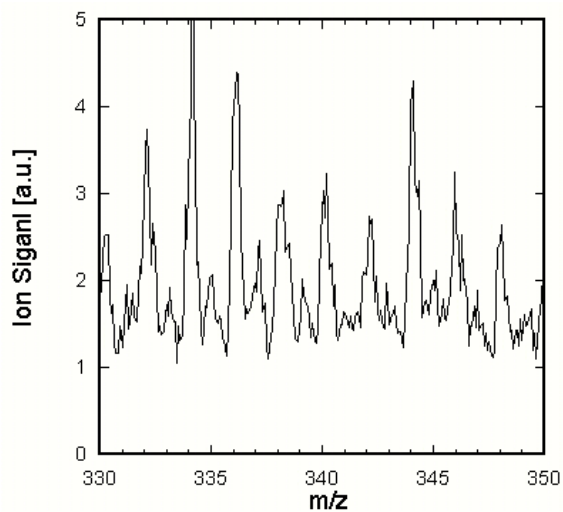

Fig.49 PeCDF

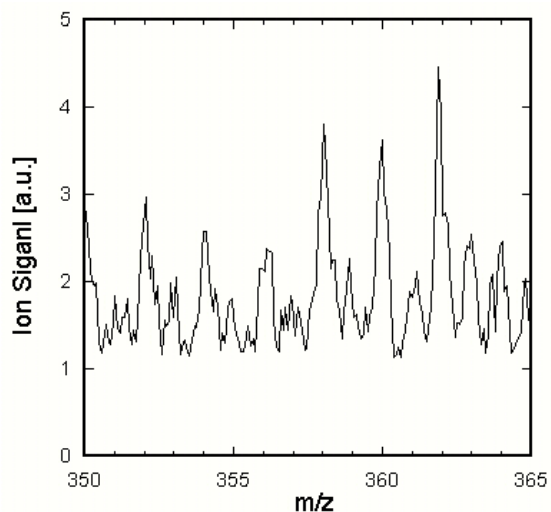

Fig.50 PeCDD

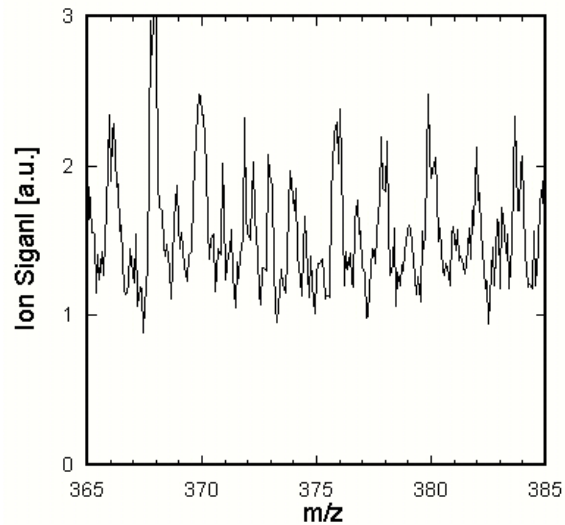

Fig.51 HxCDF

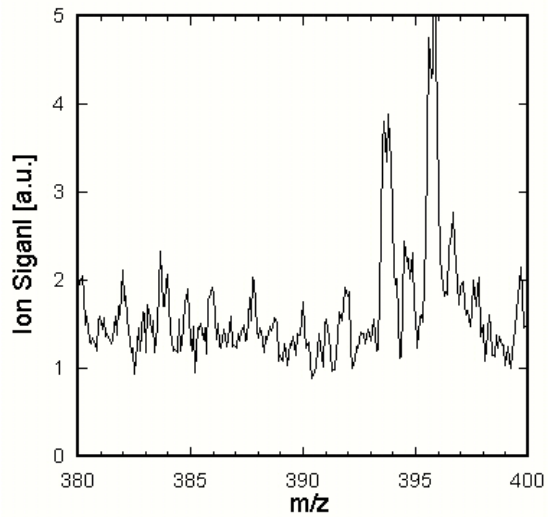

Fig.52 HxCDD

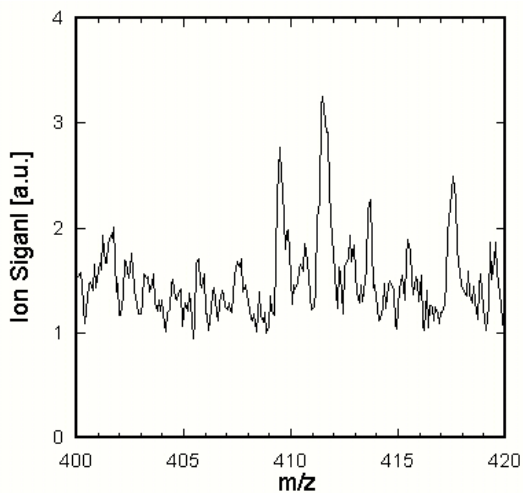

Fig.53 HpCDF

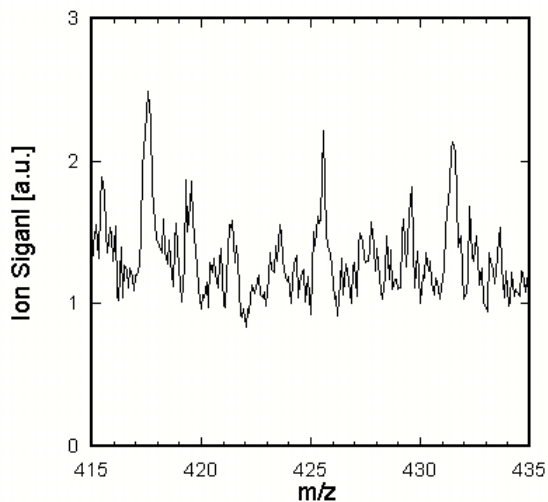

Fig.54 HpCDD

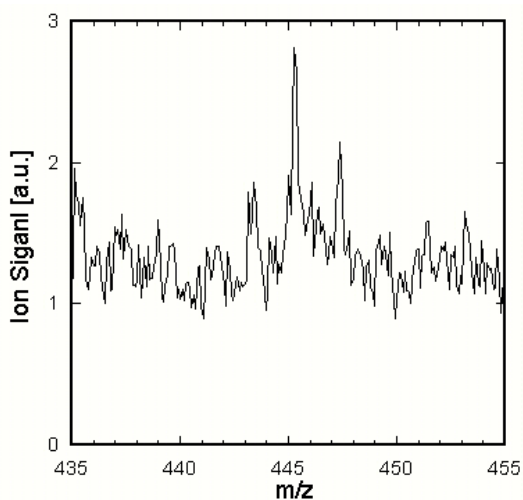

Fig.55 OCDF

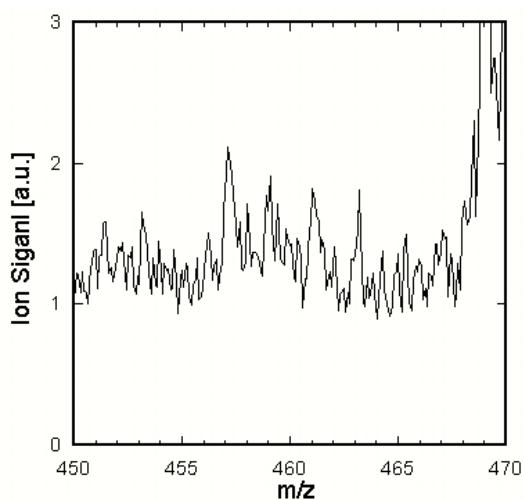

Fig.56 OCDD

It is because the some absorbed materials in TENAX were remained due to the low flow rate of helium gas.

Figure 57 is the mass spectrum obtained by RIMMPA-TOMS in the case of increasing helium flow rate to 3 L/min after the measurement end of Test number: 9/22-#2. Comparing to the data of 0.5 L/min, the ion signals increased. We thought the sample remained in the TENAX column not being pushed out.

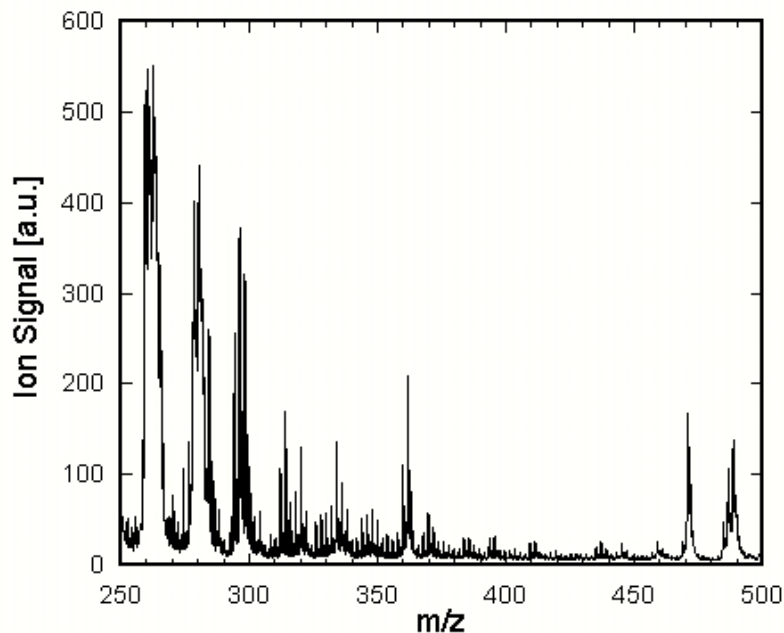

Fig.57 Mass spectrum

## 7. Conclusion

What we have performed this time through the test is

1. We struggled for adjusting the Adsorption and Heated Desorption.
2. It has taken us much time to get rid of unexpected occurrence of PAH & Poly-Chlorinated PAH that caused from Naphthalene Cu to generate Dioxin.
3. This PC-PAH causes the damages to break the congener ratio which is essential to identification of PCDDs/PCDFs because they overlap with those of PCDDs/PCDFs.

Even under this situation, we tried two types of analysis of congeners and isomers.

In the congener analysis, the peaks detected in the vicinity of mass of TeCDF, TeCDD, PeCDD, and OCDF were able to be identified. However, it was difficult to identify other congeners because PAH and chlorinated PAH contained in exhaust gas came in succession with spectra of PCDD's and PCDF's. With regard to the results of PAH or chlorinated PAH that we have got in the experiment, are shown in chart 5.

In the case of isomer analysis 2,3,4,7,8-PeCDF, we detected mass peaks in the mass number 338, 340 and 342. It was tough however, to identify and to measure because the intensity ratio of the isotopes 338, 340, 342 observed is different from the signal calculated by the existence ratio. It was not possible to identify the isotope signals of 2, 3, 4, 7, 8- PeCDF, because the mass spectra of impurities (PAH and chlorinated PAH etc.) that existed in the mass neighborhood of 2, 3, 4, 7, 8- PeCDF came in succession, and detection was obstructed.

Through this ETV test this time, we realized that the toughness in the real gas but at the same time we learned many things and eventually we have to the stage to convince that we are very close to be able to detect the isomer analysis in real gas in the very near future.

Chart 5

m/z	Compound		
260	$C_{18}H_9Cl$	$C_{18}H_{12}O_2Cl_4$	
262	$C_{18}H_{11}Cl$	$C_{18}H_{14}O_2$	
278	$C_{18}H_{12}OCl$	$C_{22}H_{14}$	
280	$C_{22}H_{16}$		
284	$C_{12}H_6S_2Cl_2$	$C_{12}H_6O_2SCl_2$	
286	$C_{20}H_{11}Cl$		
292	$C_{23}H_{16}$		
294	$C_{18}H_8Cl_2$	$C_{12}H_{10}Cl_4$	
296	$C_{18}H_{10}Cl_2$	$C_{18}H_{13}O_2Cl$	
298	$C_{12}H_7O_3S_2Cl$	$C_{18}H_{15}O_2Cl$	
304	$C_{20}H_{16}O_3$	$C_{24}H_{16}$	$C_{18}H_{24}O_4$
312	$C_{18}H_{10}OCl_2$		
314	$C_{14}H_{12}O_2SCl_2$		
318	$C_{21}H_{15}OCl$	$C_{12}H_5S_2Cl_3$	$C_{12}H_5SO_2Cl_3$
320	$C_{20}H_{10}Cl_2$		
328	$C_{22}H_{13}OCl$		
334	$C_{24}H_{11}Cl$		
336	$C_{20}H_{10}OCl_2$		
344	$C_{18}H_{10}O_3Cl_2$	$C_{22}H_{10}Cl_2$	$C_{18}H_7OCl_3$
346	$C_{18}H_9OCl_3$	$C_{22}H_{12}Cl_2$	
360	$C_{22}H_{10}OCl_2$		
362	$C_{28}H_{26}$	$C_{26}H_{15}Cl$	$C_{26}H_{18}O_2$
368	$C_{24}H_{10}Cl_2$		
380	$C_{18}H_8OCl_4$		
384	$C_{24}H_{10}OCl_2$		
394	$C_{26}H_{12}Cl_2$	$C_{26}H_{15}O_2Cl$	
396	$C_{26}H_{14}Cl_2$	$C_{26}H_{17}O_2Cl$	
410	$C_{26}H_{12}OCl_2$	$C_{26}H_{14}OCl_4$	
412	$C_{26}H_{14}OCl_2$		