



Land And  
Emergency Management  
5401R

EPA 510-B-17-003  
October 2017  
[www.epa.gov/ust](http://www.epa.gov/ust)

---

# **How To Evaluate Alternative Cleanup Technologies For Underground Storage Tank Sites**

## **A Guide For Corrective Action Plan Reviewers**

## **Chapter XI**

# **Dual-Phase Extraction**

# Contents

---

|                                                                 |       |
|-----------------------------------------------------------------|-------|
| Overview .....                                                  | XI-1  |
| Initial Screening Of DPE Effectiveness .....                    | XI-11 |
| Detailed Evaluation Of DPE Effectiveness .....                  | XI-12 |
| Site Characteristics .....                                      | XI-13 |
| Intrinsic Permeability .....                                    | XI-13 |
| Soil Structure And Stratification .....                         | XI-15 |
| Moisture Content In The Unsaturated Zone .....                  | XI-15 |
| Depth To Groundwater .....                                      | XI-16 |
| Chemical Properties .....                                       | XI-17 |
| Effective Volatility .....                                      | XI-17 |
| Chemical Sorptive Capacity .....                                | XI-19 |
| Pilot Scale Studies .....                                       | XI-19 |
| Evaluation Of The DPE System Design .....                       | XI-21 |
| Rationale For The Design .....                                  | XI-21 |
| Components Of A DPE System .....                                | XI-24 |
| Extraction Wells .....                                          | XI-25 |
| Manifold Piping .....                                           | XI-29 |
| Vapor Pretreatment .....                                        | XI-29 |
| Vapor Treatment .....                                           | XI-30 |
| Blower Selection .....                                          | XI-30 |
| Instrumentation and Controls .....                              | XI-31 |
| Optional DPE Components .....                                   | XI-32 |
| Land Surface Seals .....                                        | XI-33 |
| Injection Wells .....                                           | XI-33 |
| Evaluations Of Operation And Monitoring Plans .....             | XI-33 |
| Start-Up Operations .....                                       | XI-34 |
| Long-Term Operations .....                                      | XI-34 |
| Remediation Progress Monitoring .....                           | XI-34 |
| References .....                                                | XI-37 |
| Checklist: Can Dual-Phase Extraction Be Used At This Site? .... | XI-38 |

## List Of Exhibits

---

| <b>Number</b> | <b>Title</b>                                                                              | <b>Page</b> |
|---------------|-------------------------------------------------------------------------------------------|-------------|
| XI-1          | Typical Single-Pump DPE System . . . . .                                                  | XI-2        |
| XI-2          | Typical Multi-Pump DPE System . . . . .                                                   | XI-3        |
| XI-3          | Typical Single-Pump, DPE Extraction Well . . . . .                                        | XI-5        |
| XI-4          | Typical Multi-Pump, DPE Extraction Well . . . . .                                         | XI-6        |
| XI-5          | Advantages and Disadvantages of Single-Pump DPE . . .                                     | XI-7        |
| XI-6          | Advantages and Disadvantages of Dual-Pump DPE . . . .                                     | XI-8        |
| XI-7          | DPE Evaluation Process Flow Chart . . . . .                                               | XI-9        |
| XI-8          | Initial Screening for DPE Effectiveness . . . . .                                         | XI-12       |
| XI-9          | Key Parameters Used To Evaluate Site Characteristics<br>And Chemical Properties . . . . . | XI-13       |
| XI-10         | Vapor Pressures Of Common Petroleum Constituents . .                                      | XI-18       |
| XI-11         | Petroleum Product Boiling Ranges . . . . .                                                | XI-18       |
|               | Henry's Law Constant Of Common Petroleum<br>Constituents . . . . .                        | XI-19       |
| XI-12         | Schematic of Single Pump DPE System . . . . .                                             | XI-26       |
| XI-13         | Schematic of Dual-Pump DPE System . . . . .                                               | XI-27       |
| XI-14         | Performance Curves For Three Types Of Blowers . . . . .                                   | XI-31       |
| XI-15         | Monitoring And Control Equipment . . . . .                                                | XI-32       |
| XI-16         | System Monitoring Recommendations . . . . .                                               | XI-35       |
| XI-17         | Relationship Between Concentration Reduction And<br>Mass Removal . . . . .                | XI-36       |

# Chapter XI

## Dual-Phase Extraction

---

### Overview

Dual-phase extraction, also known as multi-phase extraction, vacuum-enhanced extraction, or bioslurping, is an in-situ technology that uses pumps to remove various combinations of contaminated groundwater, separate-phase petroleum product, and hydrocarbon vapor from the subsurface. Extracted liquids and vapor are treated and collected for disposal, or re-injected to the subsurface (where permissible). Dual-phase extraction systems can be effective in removing separate-phase product from the subsurface, thereby reducing concentrations of petroleum hydrocarbons in both the saturated and unsaturated zones of the subsurface. Dual-phase extraction systems are typically designed to maximize extraction rates; however, the technology also stimulates biodegradation of petroleum constituents in the unsaturated zone by increasing the supply of oxygen, in a manner similar to bioventing (see Chapter III for more information on bioventing).

Although the general class of technologies presented in this chapter is referred to as dual-phase extraction (DPE), significant variations in the technology exist. DPE systems often apply relatively high vacuums to the subsurface. Thus, the adjective "high-vacuum" is sometimes used to describe DPE technologies, even though all DPE systems are not high-vacuum systems. DPE technologies can be divided into two general categories, depending on whether subsurface liquid(s) and soil vapor are extracted together as a high-velocity dual-phase (liquid(s) and vapor) stream using a single pump or whether the subsurface liquid(s) and soil vapor are extracted separately using two or more pumps. Exhibits XI- 1 and XI-2 display typical single- and dual-pump DPE systems, respectively.

Single-pump systems rely on high-velocity airflow to lift suspended liquid droplets upwards by frictional drag through an extraction tube to the land surface. Single-pump vacuum extraction systems can be used to extract groundwater or combinations of separate-phase product and groundwater. The somewhat more conventional dual-pump systems use one pump to extract liquids from the well and a surface blower (the second pump) to extract soil vapor. A third DPE configuration uses a total of three pumps, including the surface blower together with one pump to extract floating product and one to extract groundwater. Because both double- and triple-pump DPE systems extract the well liquids separately from the soil vapor and are similar in operation and

Exhibit XI-1  
 Typical Single-Pump DPE System

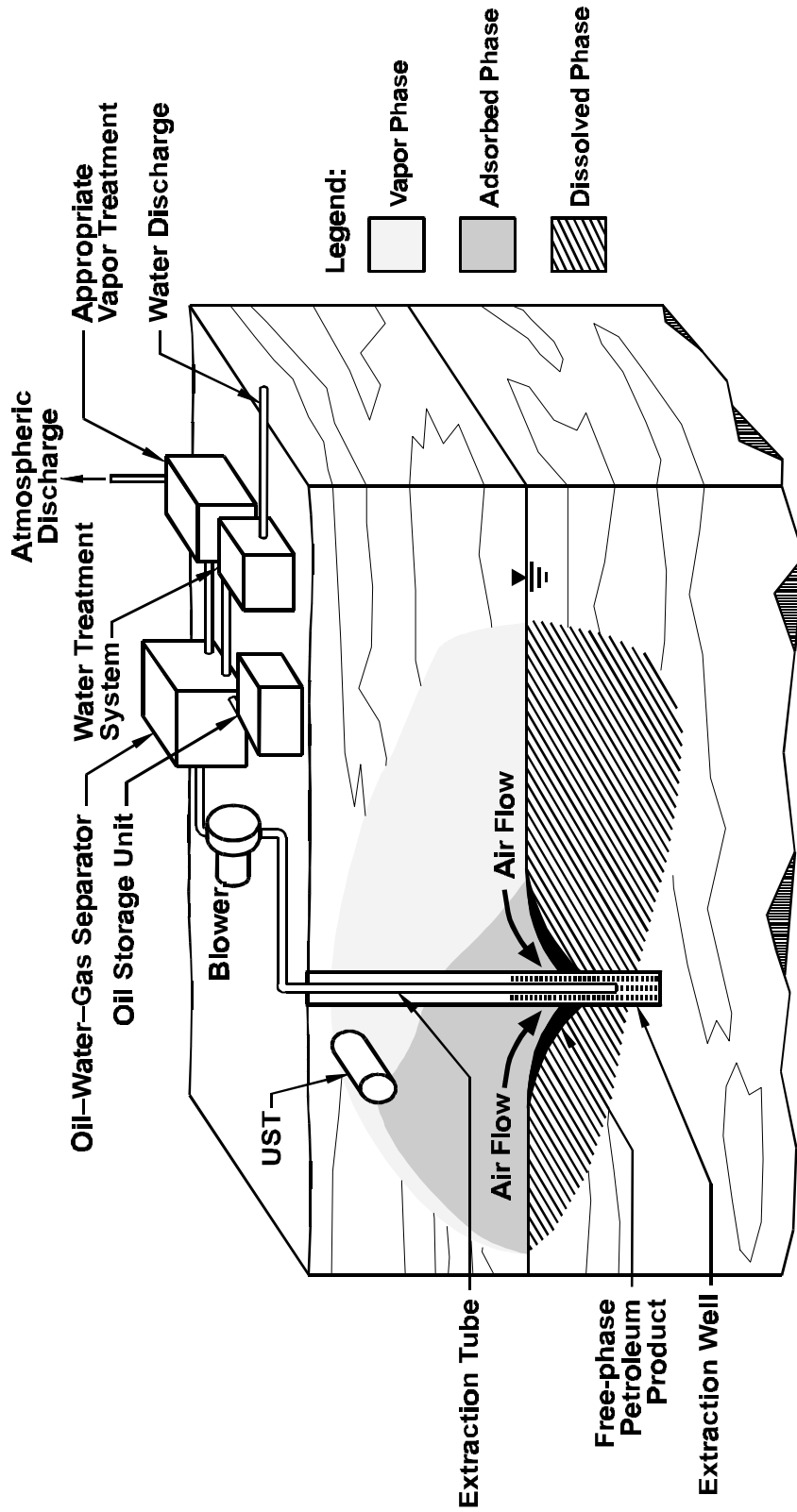
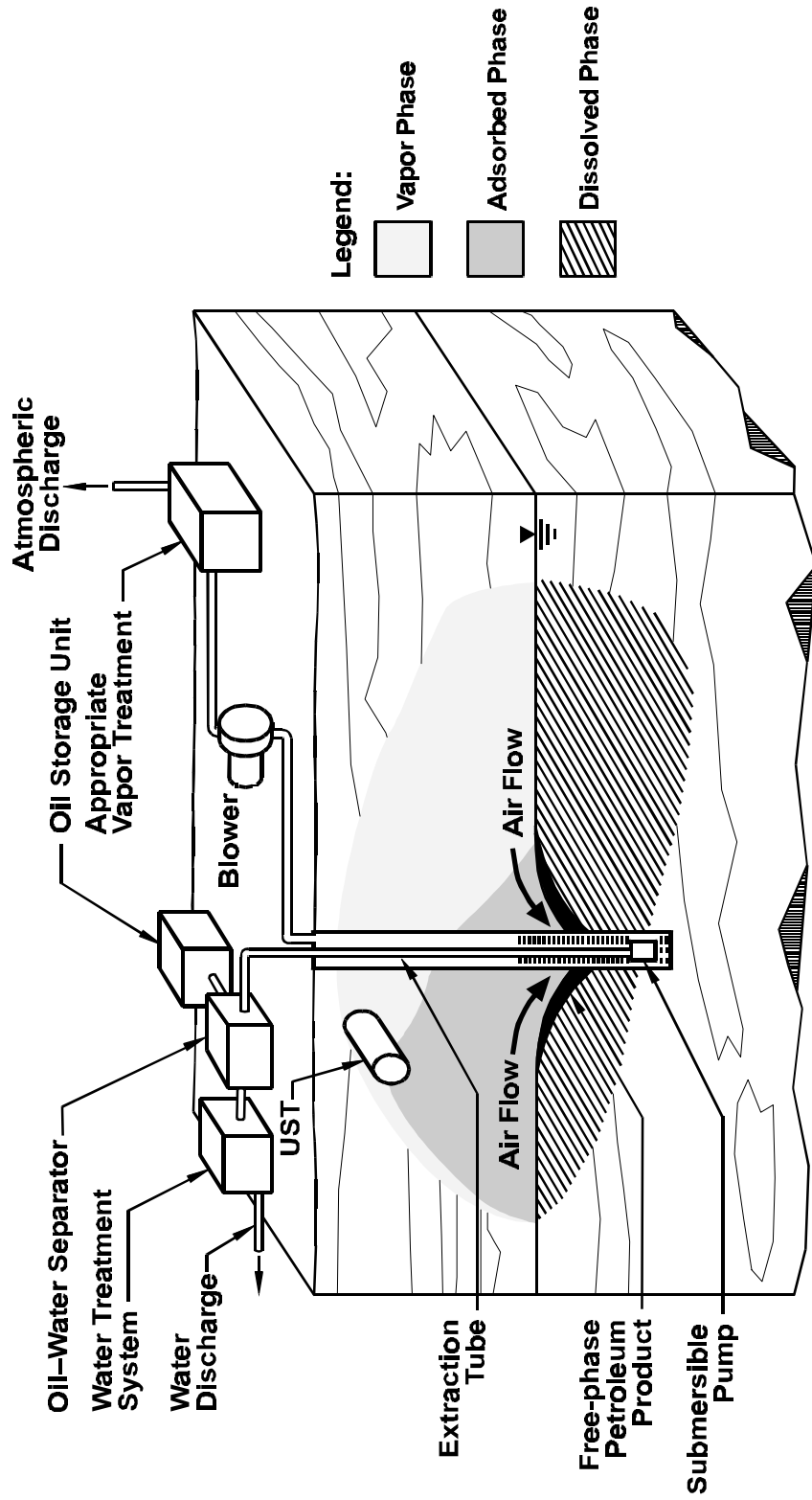

Exhibit XI-2  
 Typical Multi-Pump DPE System



application, these systems will be discussed together under the heading of "dual-pump DPE systems" in the remainder of this chapter. Exhibits X I-3 and XI-4 are diagrams of typical single-pump and dual-pump DPE extraction wells, respectively.

Vacuum groundwater extraction has been used for many decades as a standard method for extracting groundwater to control seepage or effect dewatering during construction and mining activities (Powers, 1981). Single-pump DPE systems represent a recent adaptation of this long-established technology to the task of subsurface remediation. Single-pump DPE systems are generally better suited to low-permeability conditions, and they are difficult to implement at sites where natural fluctuations in groundwater levels are substantial. United States patents exist on certain applications of single-pump DPE systems (Hess et al., 1991; Hajali et al., 1992; Hess et al., 1993). Single-pump DPE technology is sometimes referred to as bioslurping (U.S. Air Force, 1994).

Dual-pump DPE systems are simply a combination of traditional soil vapor extraction (SVE) and groundwater (and/or floating product) recovery systems. Dual-pump systems tend to be more flexible than single-pump systems, making dual-pump systems easier to apply over a wider range of site conditions (e.g., fluctuating water tables, wide permeability ranges); however, equipment costs are higher.

The vacuum applied to the subsurface with DPE systems creates vapor-phase pressure gradients toward the vacuum well. These vapor-phase pressure gradients are also transmitted directly to the subsurface liquids present, and those liquids existing in a continuous phase (e.g., water and "free" petroleum product) will flow toward the vacuum well in response to the imposed gradients (the term "free" product is a commonly used, though imprecise term because a greater fraction of resident petroleum product may be recovered using vacuum-enhanced DPE compared to the fraction of product recoverable using gravity drainage alone). The higher the applied vacuum, the larger the hydraulic gradients that can be achieved in both vapor and liquid phases, and thus the greater the vapor and liquid recovery rates.

Dramatic enhancements in both water and petroleum product recovery rates resulting from the large hydraulic gradients attainable with DPE systems have been reported in the literature (Blake and Gates, 1986; Blake, et al., 1990; Bruce, et al., 1992). The depressed groundwater table that results from these high recovery rates serves both to hydraulically control groundwater migration and to increase the efficiency of vapor extraction. The remedial effectiveness of DPE within the zone of dewatering that commonly develops during DPE application



**Exhibit XI-3**  
**Typical Single-Pump, DPE Extraction Well**

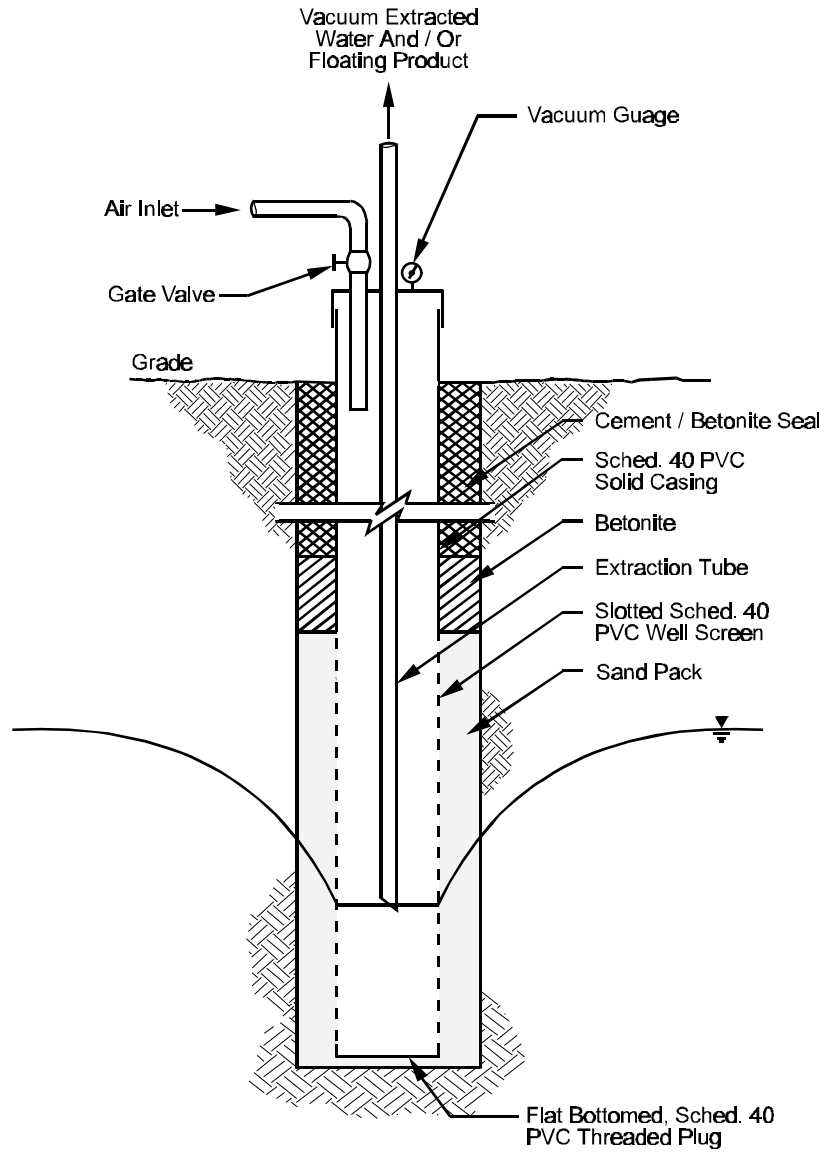
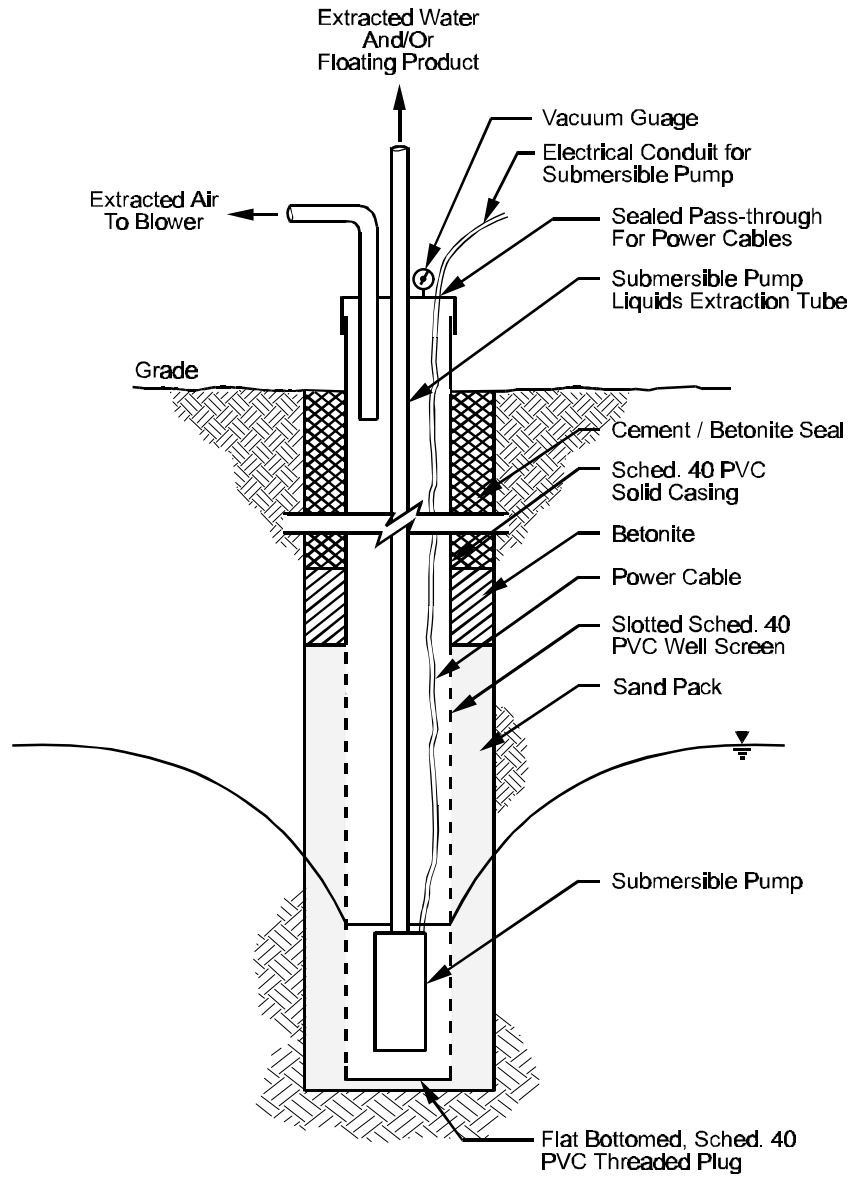

Exhibit XI-4  
Typical Multi-Pump, DPE Extraction Well



should be greater than that of air sparging due to the more uniform air flow developed using DPE (Johnson, et al., 1992).

Because of the varied nature of DPE systems, the conceptual design objectives for DPE can vary widely. DPE is often selected because it enhances groundwater and/or product recovery rates, especially in layered, fine-grained soils. The application of DPE also maximizes the effectiveness of SVE by lowering the water table and therefore increasing air-phase permeabilities in the vadose zone. Finally, DPE can enhance biodegradation by substantially increasing the supply of oxygen to the vadose zone. Exhibits XI-5 and XI-6 list the advantages and disadvantages of single-pump and dual-pump DPE systems, respectively.

| <b>Exhibit XI-5<br/>Advantages and Disadvantages of Single-Pump DPE</b>                                                                                                                                                                                                                                                                                                                                                                                                                                                                                                                                                                                                                          |                                                                                                                                                                                                                                                                                                                                                                                                                                                                                                                                     |
|--------------------------------------------------------------------------------------------------------------------------------------------------------------------------------------------------------------------------------------------------------------------------------------------------------------------------------------------------------------------------------------------------------------------------------------------------------------------------------------------------------------------------------------------------------------------------------------------------------------------------------------------------------------------------------------------------|-------------------------------------------------------------------------------------------------------------------------------------------------------------------------------------------------------------------------------------------------------------------------------------------------------------------------------------------------------------------------------------------------------------------------------------------------------------------------------------------------------------------------------------|
| <b>Advantages</b>                                                                                                                                                                                                                                                                                                                                                                                                                                                                                                                                                                                                                                                                                | <b>Disadvantages</b>                                                                                                                                                                                                                                                                                                                                                                                                                                                                                                                |
| <ul style="list-style-type: none"> <li>○ Proven performance in low-permeability soils. Requires no downhole pumps.</li> <li>○ Minimal disturbance to site operations.</li> <li>○ Short treatment times (usually 6 months to 2 years under optimal conditions).</li> <li>○ Substantially increases groundwater extraction rates.</li> <li>○ Can be applied at sites with floating product, and can be combined with other technologies, such as air sparging and bioremediation.</li> <li>○ Can be used under buildings and other locations that cannot be excavated.</li> <li>○ Can reduce the cost of groundwater treatment through air stripping within the vacuum extraction tube.</li> </ul> | <ul style="list-style-type: none"> <li>○ Expensive to implement at sites with medium to high-permeability soils.</li> <li>○ Difficult to apply to sites where the water table fluctuates.</li> <li>○ Treatment may be expensive for extracted vapors and for oil-water separation</li> <li>○ Can extract a large volume of groundwater that may require treatment.</li> <li>○ Requires specialized equipment with sophisticated control capability.</li> <li>○ Requires complex monitoring and control during operation.</li> </ul> |

This chapter will assist you in evaluating a corrective action plan (CAP) that proposes DPE as a remedy for petroleum-contaminated soil and groundwater. The evaluation process, which is summarized in the flow diagram shown in Exhibit XI-7, will serve as a roadmap for the

| <b>Exhibit XI-6<br/>Advantages and Disadvantages of Multi-Pump DPE</b>                                                                                                                                                                                                                                                                                                                                                                                                                                                                                                                                                                                                                            |                                                                                                                                                                                                                                                                                                                                                                                                                                                           |
|---------------------------------------------------------------------------------------------------------------------------------------------------------------------------------------------------------------------------------------------------------------------------------------------------------------------------------------------------------------------------------------------------------------------------------------------------------------------------------------------------------------------------------------------------------------------------------------------------------------------------------------------------------------------------------------------------|-----------------------------------------------------------------------------------------------------------------------------------------------------------------------------------------------------------------------------------------------------------------------------------------------------------------------------------------------------------------------------------------------------------------------------------------------------------|
| <b>Advantages</b>                                                                                                                                                                                                                                                                                                                                                                                                                                                                                                                                                                                                                                                                                 | <b>Disadvantages</b>                                                                                                                                                                                                                                                                                                                                                                                                                                      |
| <ul style="list-style-type: none"> <li>○ Proven performance under a wide range of conditions; readily available equipment.</li> <li>○ Minimal disturbance to site operations.</li> <li>○ Short treatment times (usually 6 months to 2 years under optimal conditions).</li> <li>○ Substantially increases groundwater extraction rates.</li> <li>○ Flexible applications to sites with water-table fluctuations or widely ranging permeabilities.</li> <li>○ Can be applied to sites with floating product, and can be combined with other technologies, such as air sparging and bioremediation.</li> <li>○ Can be used under buildings and other locations that cannot be excavated.</li> </ul> | <ul style="list-style-type: none"> <li>○ Effectiveness less certain when applied to soils with very low permeabilities or when applied with lack of sufficient information of subsurface conditions.</li> <li>○ May require costly treatment for atmospheric discharge of extracted vapors.</li> <li>○ May require costly oil/water separation and groundwater treatment.</li> <li>○ Requires complex monitoring and control during operation.</li> </ul> |

decisions you will make during your evaluation. The evaluation can be divided into the following steps.

- **Step 1: An initial screening of DPE effectiveness**, which will allow you to quickly gauge whether DPE is likely to be effective, moderately effective, or ineffective for a given site-specific application.
- **Step 2: A detailed evaluation of DPE effectiveness**, which provides further screening criteria to confirm whether DPE is likely to be effective at a given site. To complete the detailed evaluation, you will need to identify key site characteristics and soil properties in the CAP, compare them with conditions under which DPE is typically effective, decide whether pilot studies are needed, and conclude whether DPE is likely to be effective for the site-specific application.
- **Step 3: An evaluation of the DPE system design**, which will allow you to determine whether the rationale for the design has been appropriately defined based on pilot study data or other studies, whether the necessary design components have been specified, and

**Exhibit XI-7  
DPE Evaluation Process Flow Chart**

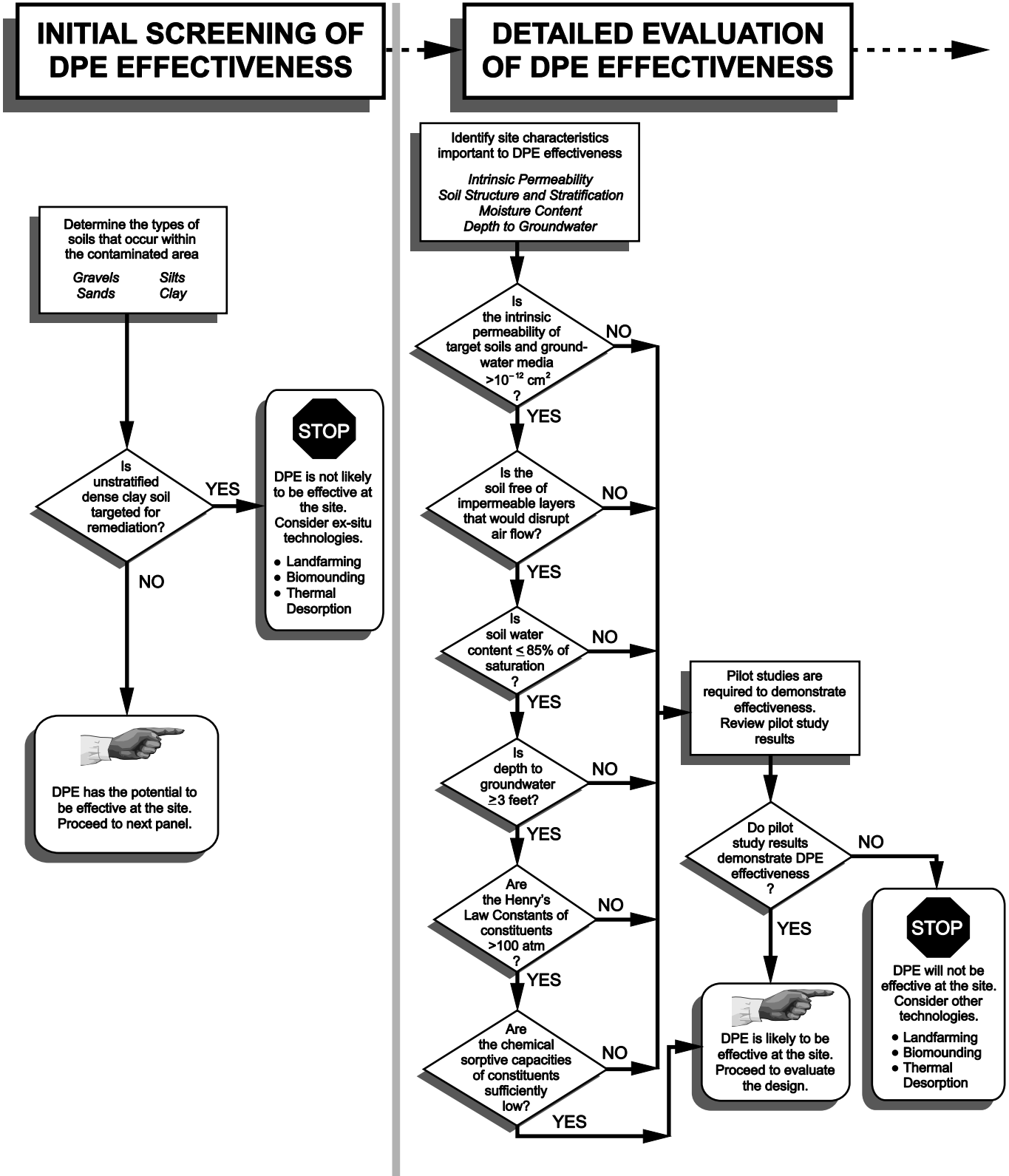

**Exhibit XI-7  
DPE Evaluation Process Flow Chart**

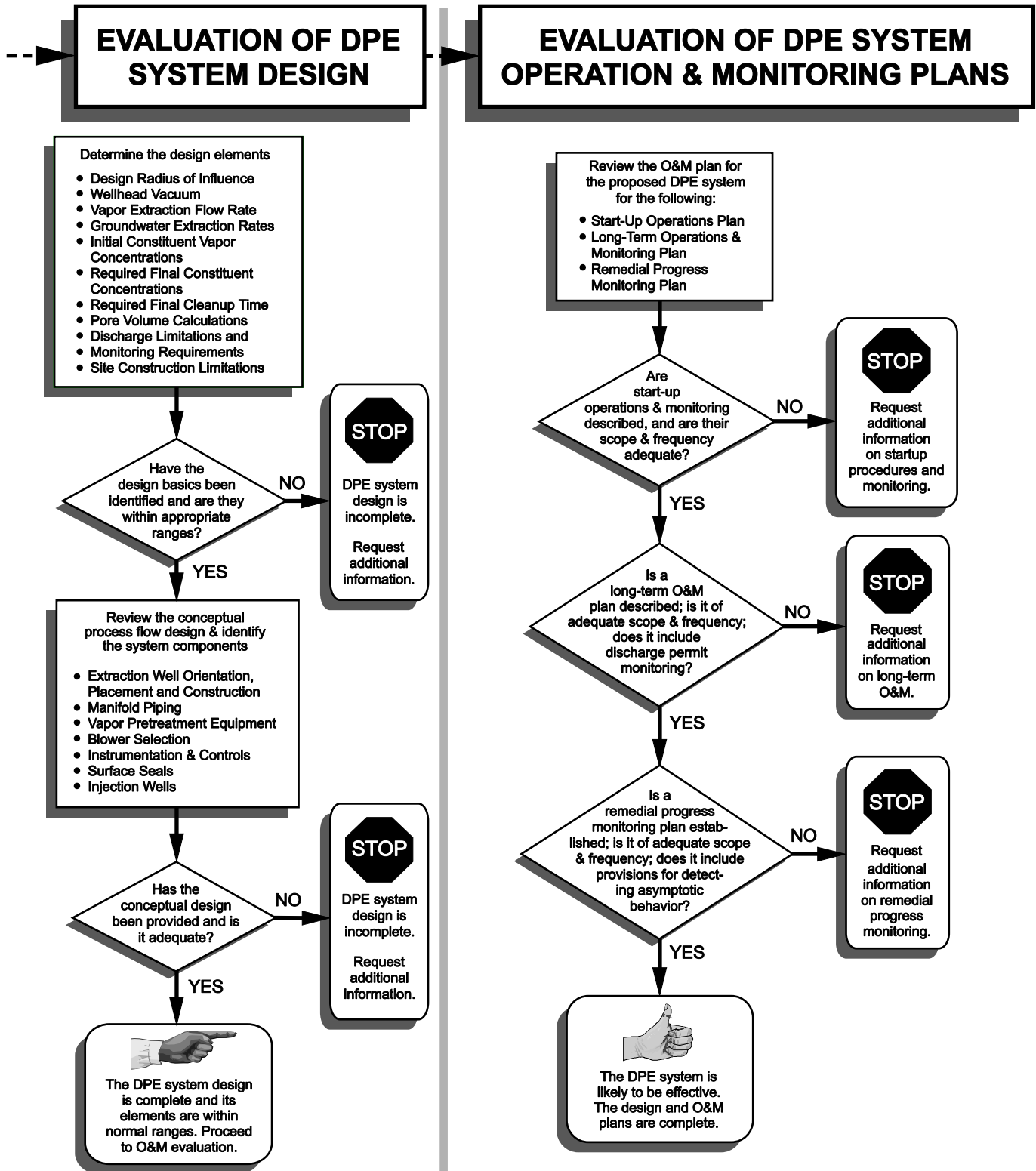

whether the construction process flow designs are consistent with standard practice.

- **Step 4: An evaluation of the operation and monitoring plans**, which will allow you to determine whether plans for start-up and long-term monitoring of the system are of sufficient scope and frequency and whether remedial progress monitoring plans are appropriate.

## **Initial Screening Of DPE Effectiveness**

---

Because of the differences in application of various types of DPE systems and the complexity of DPE, determining whether DPE will work effectively at a given site is complex. This section discusses the key site parameters that should be evaluated in deciding whether DPE will be a viable remedy for a particular site. The key site parameters include:

- *Permeability* of the petroleum-contaminated soils and aquifer media. Permeability affects the rates at which groundwater and soil vapors can be extracted and controls the pore volume exchange rate.
- *Volatility* of the petroleum constituents. Volatility determines the rate at and degree to which petroleum constituents will vaporize to the soil vapor state.

In general, the type of soil (e.g., clay, silt, sand) will determine its *permeability*. Fine-grained soils (e.g., clays and silts) have lower permeability than coarse-grained soils (e.g., sands and gravels). Permeability usually varies significantly with depth; for screening purposes, consider the effects of the most permeable soil that is found areally continuous through a significant portion of the chemically-affected soil profile. Permeability affects remediation in both the vadose and groundwater zones.

The *volatility* of a petroleum product or its constituents is a measure of its ability to vaporize and can be measured in several ways. Because petroleum products are highly complex mixtures of chemical constituents, the volatility of the product mixture can be gauged most easily by its boiling point. If the boiling point is low, the volatility of the product will be high. Conversely, petroleum products with higher boiling points are less volatile. If product volatility is low, DPE will be less effective in removing petroleum constituents in the vapor phase from the unsaturated zone.

Exhibit XI-8 is an initial screening tool that can be used to help assess the potential effectiveness of DPE for a given site. It provides a

**Exhibit XI-8  
Initial Screening for DPE Effectiveness**

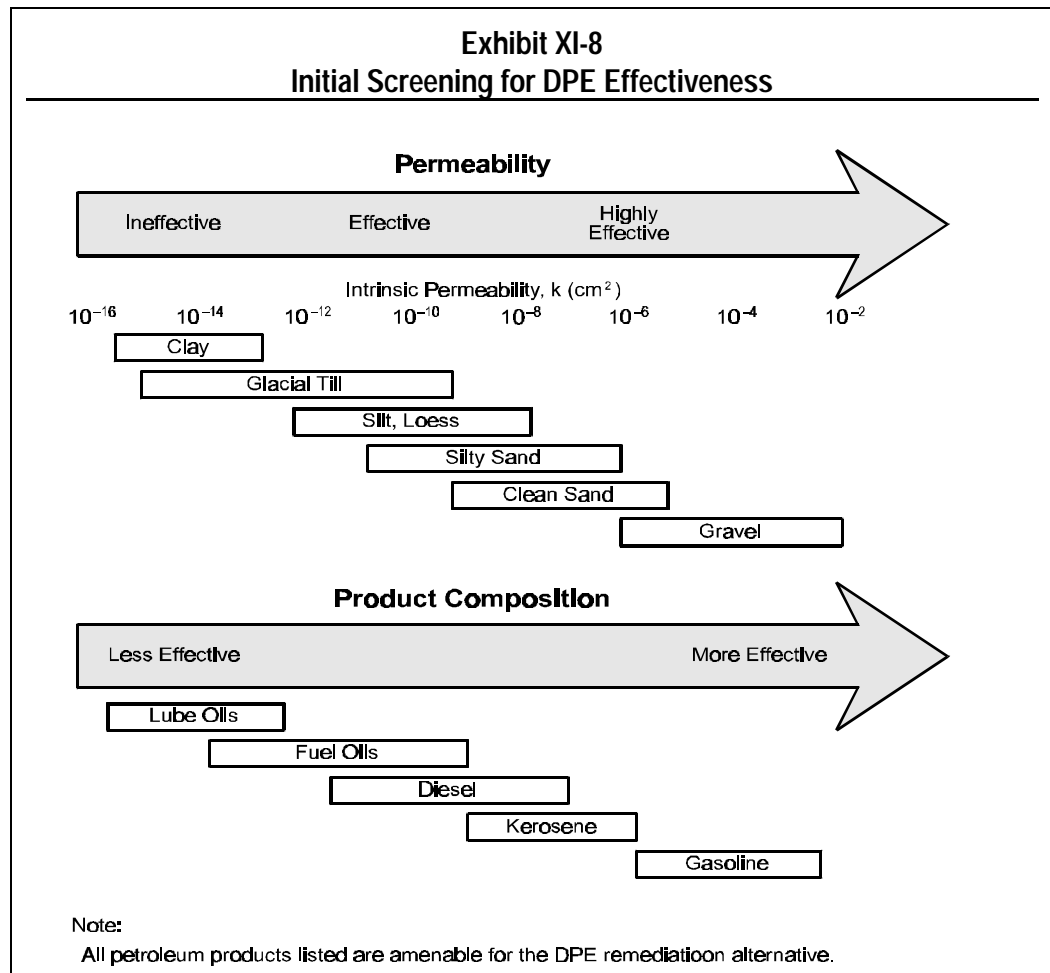

range of soil permeabilities for typical soil types as well as ranges in composition for typical petroleum products. Use this screening tool to make an initial assessment of the potential effectiveness of DPE. To use this tool, you should scan the CAP to determine the soil type present and the type of petroleum product released to assess the potential remedial effectiveness of DPE at the site.

Information provided in the following section will allow a more thorough effectiveness evaluation and will identify issues that could require special design considerations.

**Detailed Evaluation Of DPE Effectiveness**

Once you have completed the initial screening and determined that DPE is potentially effective for the soil permeability and petroleum products composition present, you need to further evaluate the CPA to



confirm that DPE will be effective. While the initial screen focused on permeability and constituent volatility, the detailed evaluation should consider a broader range of site and constituent characteristics, which are listed in Exhibit XI-9.

The factors listed on Exhibit XI-9 largely control the initial contaminant mass extraction rate, which will decrease during DPE operation as concentration of volatile organics in the soil (and soil vapor) are reduced. However, based on the total contaminant mass present in soils and a reasonable remediation time frame, acceptable ranges for the site-specific factors can be determined.

| <b>Exhibit XI-9</b>                                                                                                             |                                                    |
|---------------------------------------------------------------------------------------------------------------------------------|----------------------------------------------------|
| <b>Key Parameters Used To Evaluate Site Characteristics And Chemical Properties</b>                                             |                                                    |
| <b>Site Characteristics</b>                                                                                                     | <b>Chemical Properties</b>                         |
| Intrinsic permeability<br>Soil structure and stratification<br>Moisture content in the unsaturated zone<br>Depth to groundwater | Effective volatility<br>Chemical sorptive capacity |

The remainder of this section describes these parameters, why each is important to DPE, how they can be determined, and the range of each parameter considered appropriate for DPE. Keep in mind that the site-specific factors that govern the effectiveness of DPE are generally the same as those that govern the effectiveness of both SVE and bioventing.

## **Site Characteristics**

### ***Intrinsic Permeability***

*Intrinsic permeability* is a measure of the ability of soil to transmit fluids and is the most important factor in determining the effectiveness of DPE because it controls the pore volume rates of groundwater and soil vapor extraction. In addition, intrinsic permeability influences the amount of oxygen supply that can be delivered to the unsaturated zone bacteria and it controls the groundwater drawdown associated with given extraction rates.

Intrinsic permeability varies over 13 orders of magnitude (from  $10^{-16}$  to  $10^{-3}$  cm<sup>2</sup>) for the full range of earth materials, although a more limited range applies for most soil types ( $10^{-13}$  to  $10^{-5}$  cm<sup>2</sup>). Intrinsic permeability is best determined from field or laboratory tests, but it can

be estimated within one or two orders of magnitude from soil boring log data and laboratory tests. Coarse-grained soils (e.g., sands) have higher intrinsic permeability than fine-grained soils (e.g., clays, silts). Note that the ability of a soil to transmit air, which is of great importance in DPE, is reduced by the presence of soil water, which can block the soil pores and reduce air flow. The presence of soil water is especially important in fine-grained soils, which tend to retain pore water.

The relatively high vacuum achievable with DPE systems is generally effective in extracting liquids from relatively uniform soils with permeabilities as low as  $10^{-11}$  cm<sup>2</sup>. Single-pump DPE technology is best suited to sites with intrinsic permeabilities ranging from  $10^{-9}$  to  $10^{-11}$  cm<sup>2</sup>, although it can be effective at sites with permeabilities as low as  $10^{-12}$  cm<sup>2</sup>. Single-pump DPE systems are generally not economical at sites with permeabilities greater than  $10^{-9}$  cm<sup>2</sup> because of the large air flow required to maintain an adequate vacuum. There is no maximum permeability limit for application of dual-pump DPE systems, provided sufficient air confinement exists above the soils targeted for remediation (see Depth to Groundwater, below). However, the added cost of vacuum enhanced extraction is not warranted strictly to enhance groundwater recovery rates in more permeable soils, and DPE should only be considered for highly permeable soils in cases where soil and groundwater remediation is required.

At most sites, intrinsic permeability varies significantly with depth, and therefore the effectiveness of DPE systems depends on the soil stratification. This relationship is further discussed in the "Soil Structure and Stratification" section on page XI- 15. Soils with very low intrinsic permeabilities (i.e.,  $< 10^{-11}$  ~ cm<sup>2</sup>) can be dewatered if they are interbedded with coarser-grained sediments. The coarser-grained sediments are dewatered first, then the fine-grained sediments drain to the dewatered layers, which are under high vacuum.

Hydraulic conductivity is a measure of the ability of soils to transmit water. Hydraulic conductivity can be determined from aquifer tests, including slug tests and pumping tests. You can convert hydraulic conductivity to intrinsic permeability using the following equation:

$$k = K (\mu/\rho g)$$

where:  $k$  = intrinsic permeability (cm<sup>2</sup>)  
 $K$  = hydraulic conductivity (cm/sec)  
 $\mu$  = water dynamic viscosity (g/cm · sec)  
 $\rho$  = water density (g/cm<sup>3</sup>)

$g = \text{acceleration due to gravity (cm/sec}^2\text{)}$

At 20°C:  $\mu/\rho g = 1.02 \times 10^{-5} \text{ cm} \cdot \text{sec}$

To convert  $k$  from  $\text{cm}^2$  to darcy, multiply by  $10^8$ .

*The effective air-phase permeability* of the petroleum-contaminated vadose-zone soils, along with the supply of air to the subsurface, controls the air-flow rates achievable using DPE. The extracted air-flow rate largely determines both the efficiency of vapor extraction and the rates at which oxygen can be supplied to hydrocarbon-degrading microorganisms in the subsurface. The effective air-phase permeability is the product of the intrinsic soil permeability and the relative permeability of the soil to the air phase in situ. The relative permeability to air is greatest at low volumetric contents (or saturations) of soil-water and petroleum product, and decreases as the liquid content increases owing to the blockage of soil pores by the liquid(s).

### ***Soil Structure And Stratification***

Soil structure and stratification are important to DPE because they affect how and where soil vapors will flow within the soil matrix during extraction. Structural characteristics such as microfracturing and secondary porosity features (e.g., root holes, mole holes, and worm holes) can result in higher permeabilities than expected for certain soils (e.g., clays). Increased flow will occur in the fractured but not in the unfractured media. Stratification of soils with different permeabilities can dramatically increase the lateral flow of soil vapors in more permeable strata while reducing the soil vapor flow through less permeable strata. Consequently, a significant volume of contaminated soil can remain untreated, and the remaining residual contamination can act as a future source of groundwater contamination.

You can determine soil structure and stratification by reviewing soil boring logs for wells or borings and by examining geologic cross-sections. Verify that soil types have been identified, that visual observations of soil structure have been documented, and that boring logs are of sufficient detail to define soil stratification. Special design provisions may be necessary for stratified soils to ensure that less-permeable strata are adequately vented.

### ***Moisture Content In The Unsaturated Zone***

High moisture content in the unsaturated zone soils can reduce soil permeability and, therefore, the effectiveness of DPE in removing hydrocarbons from the unsaturated zone. Generally, with water

saturation levels equal to or greater than 85 percent of field capacity, air flow is blocked because the effective air permeability is essentially zero.

Airflow is particularly important for soils within the capillary fringe, where a significant portion of petroleum constituents often accumulate. Fine-grained soils create a thicker capillary fringe than coarse-grained soils. The thickness of the capillary fringe can usually be determined from soil boring logs (i.e., in the capillary fringe, soils are usually described as moist or wet). By lowering the Groundwater table, DPE can effectively vent soils within the capillary fringe.

### ***Depth To Groundwater***

DPE is difficult to apply at sites where the water table is located less than 3 feet below the land surface. This difficulty is due primarily to the high potential for air-flow short circuiting due to large vertical air-flow rates in the immediate vicinity of extraction wells within highly permeable soils. Vertical short circuiting of air flow prevents more uniform and lateral air flow through the affected soils. If a natural barrier (e.g., shallow moist clay layer or sealed building slab) does not exist to provide the necessary air confinement near the ground surface, then an engineered surface seal must be installed to prevent the undesirable air-flow short circuiting at sites with shallow groundwater.

Groundwater upwelling that can occur within SVE wells under vacuum pressures generally does not pose a problem for DPE systems because of the concurrent Groundwater extraction that offsets potential upwelling in the vicinity of DPE wells. Groundwater extraction with DPE can be used to lower the water table and significantly expand the thickness of unsaturated soil through which air can be circulated, thus enhancing remedial effectiveness in shallow soils.

If water-table elevations fluctuate significantly at the site, special design provisions must be made to accommodate them. Knowledge of water table elevation fluctuations is especially critical if a single-pump DPE system is in use because the inlet ends of the downhole extraction tubes must be kept at or very near the liquid-gas interface in the wells to maintain the entrainment of suspended liquid droplets within the extracted air stream. As Groundwater levels fluctuate, the liquid-gas interface will move accordingly, making it difficult to keep the vacuum extraction tubes in the optimal position for extraction of the air/droplet stream.

## Chemical Properties

### *Effective Volatility*

*Effective volatility* controls the rate at and degree to which constituents will vaporize from the adsorbed and aqueous phases in the unsaturated zone to the soil-vapor phase. The effective volatility of petroleum constituents in the subsurface depends on whether mobile free-phase product is present. If free-phase product is not present, the effective volatility of petroleum constituents is characterized by their Henry's law constants. In general, Henry's law constants increase as the boiling points of the constituents decreases. When free petroleum product exists in the subsurface, the product directly contacts soil vapor, and the effective volatility is given by the constituent's saturation vapor concentration times the mole fraction of the constituent in the product mixture (Raoult's Law).

*Vapor pressure* of a constituent is the pressure that a vapor exerts when in equilibrium with its pure liquid or solid form. This is an approximate measure of its tendency to evaporate. Constituents with higher vapor pressures ( $> 0.5$  mm Hg) are generally volatilized efficiently by the induced air stream of DPE systems. Constituents with vapor pressures less than 0.5 mm Hg will not volatilize to a significant degree and are primarily remediated by in-situ biodegradation by microorganisms.

As previously discussed, petroleum products contain many different chemical constituents. Depending on its vapor pressure, each constituent will be volatilized to different degrees by a DPE system. If concentrations of volatile constituents are significant, treatment of extracted vapors may be needed. Exhibit XI-10 lists the vapor pressures of common petroleum constituents.

Boiling point is another measure of constituent volatility. Because of their complex constituent compositions, petroleum products are often classified by their boiling point ranges rather than their vapor pressures. Products with boiling points of less than about 250°C to 300°C are sufficiently volatile to be amenable to physical removal from the unsaturated zone by volatilization in a DPE system. Nearly all gasoline constituents, a portion of kerosene and diesel fuel constituents, and a lesser portion of heating oil constituents can be removed by volatilization. Biodegradation will also contribute to removal of these constituents and will be a primary mechanism for removal of heavier, less volatile constituents. If the petroleum product at the site comprises predominantly low-volatility constituents, the DPE system should be designed to maximize biodegradation, in a manner similar to bioventing

| Exhibit XI-10<br>Vapor Pressures Of Common Petroleum Constituents |                                   |
|-------------------------------------------------------------------|-----------------------------------|
| Constituent                                                       | Vapor Pressure<br>(mm Hg at 20°C) |
| Methyl t-butyl ether                                              | 245                               |
| Benzene                                                           | 76                                |
| Toluene                                                           | 22                                |
| Ethylene dibromide                                                | 11                                |
| Ethylbenzene                                                      | 7                                 |
| Xylenes                                                           | 6                                 |
| Naphthalene                                                       | 0.5                               |
| Tetraethyl lead                                                   | 0.2                               |

(see Chapter III), or bioventing could be used in lieu of DPE. If, however, the constituents are primarily volatile (e.g., gasoline), then higher air flow, similar to that used in conventional SVE systems, would be appropriate (see Chapter II). The boiling point ranges for common petroleum products are shown in Exhibit XI-11.

| Exhibit XI-11<br>Petroleum Product Boiling Ranges |                       |
|---------------------------------------------------|-----------------------|
| Product                                           | Boiling Range<br>(°C) |
| Gasoline                                          | 40 to 205             |
| Kerosene                                          | 180 to 300            |
| Diesel fuel                                       | 200 to 338            |
| Heating oil                                       | > 275                 |
| Lubricating oils                                  | Nonvolatile           |

*Henry's law constant* is the partition coefficient that relates the concentration of a constituent dissolved in water to its partial vapor pressure under equilibrium conditions. In other words, it describes the relative tendency for a dissolved constituent to exist in the vapor phase. Henry's law constant is a measure of the degree to which constituents that are dissolved in soil moisture or groundwater will volatilize for physical removal by DPE. Henry's law constants for several common constituents found in petroleum products are shown in Exhibit XI-12. Constituents with Henry's law constants of greater than 100 atmospheres are considered sufficiently volatile to be physically removed with extracted soil vapor.

| <b>Exhibit XI-12</b>                                         |                                       |
|--------------------------------------------------------------|---------------------------------------|
| <b>Henry's Law Constant Of Common Petroleum Constituents</b> |                                       |
| <b>Constituent</b>                                           | <b>Henry's Law Constant<br/>(atm)</b> |
| Tetraethyl lead                                              | 4,700                                 |
| Ethylbenzene                                                 | 359                                   |
| Xylenes                                                      | 266                                   |
| Benzene                                                      | 230                                   |
| Toluene                                                      | 217                                   |
| Naphthalene                                                  | 72                                    |
| Ethylene dibromide                                           | 34                                    |
| Methyl t-butyl ether                                         | 27                                    |

### ***Chemical Sorptive Capacity***

The chemical sorptive capacity determines the amount and degree of adsorption of constituents onto the soils and aquifer media. The higher the sorptive capacity of the soil, the more difficult the removal of constituents from the subsurface. The sorptive capacity is described by the soil-water partition coefficient,  $K_d$ , which is primarily a function of the organic carbon-water partition coefficient,  $K_{oc}$  (a chemical-specific parameter) and the fractional content of soil organic carbon,  $f_{oc}$  (a soil-specific parameter). For a given petroleum constituent, the sorptive capacity (and thus the difficulty of remediation) tends to increase as the soil becomes finer grained. The sorptive capacity affects the remedial higher sorption decreases vadose and groundwater zones. Although higher sorptive decreases remedial effectiveness, it also reduces the risk of hydrocarbon transport from affected soil to underlying groundwater or to the atmosphere, thus decreasing the need for thorough remediation (i.e., increasing the residual chemical concentrations) that may be safely left behind in the targeted soils.

### **Pilot Scale Studies**

After you have examined the data in the CAP to gauge the potential effectiveness of DPE, you will be in a position to decide if DPE is likely to be highly effective, somewhat effective, or ineffective given the site conditions. If the site shows marginal to moderate potential for effectiveness to DPE, you should evaluate the design closely and verify that adequate DPE pilot studies have been completed at the site and that the test results indicate DPE should be effective.

While pilot studies are valuable to any DPE evaluation and design, they are critical in cases where the screening-level assessment of the site conditions indicates only moderate to marginal applicability to DPE. Ideally, a small-scale pilot version of the actual DPE system intended for use at the site should be tested. For small sites, where the volume of soil requiring remediation is less than roughly 2000 cubic yards, it may not be economically attractive to conduct thorough DPE pilot tests in the field. Nevertheless, it is advisable to at least conduct a simple soil vapor extraction (SVE) test to verify that soil vapor can be extracted at achievable vacuum pressures. Also, aquifer testing is recommended to gather information needed to design the groundwater extraction portion of the DPE system.

For SVE testing, different extraction rates and wellhead vacuums are applied to the well to determine optimal operating conditions. The vacuum influence is measured at increasing distances from the extraction well using vapor probes or existing wells to establish the pressure field induced in the subsurface by the extraction system. The pressure field measurements can be used to define the radius of vacuum influence for the vadose-zone portion of the DPE system. Vapor concentrations should also be measured two or more times during the pilot testing to estimate the initial vapor concentrations that might be expected of a full-scale system at the site. This information serves as the basis for the vapor treatment system design. If an extended pilot test is conducted, long-term changes in soil-vapor concentrations can be used to assess how concentrations will vary over time, and to estimate the time required for full remediation.

Mistakes in the SVE field test commonly lead to erroneous conclusions regarding the potential effectiveness of DPE. Sometimes, the applied vacuum is too great, and the water level within the well casing rises rapidly to a level above the slotted portion of the well casing. When the applied vacuum is too high, no air can be extracted from the subsurface, leading to the erroneous conclusion that DPE cannot be applied at the site. Similarly, DPE is erroneously thought to be infeasible because the results from a simple pumping aquifer test (using conventional pumps) indicate that insufficient production of groundwater and/or petroleum product is obtained. In such cases, the high vacuum achievable with DPE systems can greatly enhance groundwater and/or product recovery, and DPE could still be a potentially effective remedy for low permeability sites. This illustrates the importance of actual DPE pilot testing.

To assess the groundwater flow parameters necessary to design the groundwater extraction portion of the DPE system, aquifer testing should be conducted. The use of DPE equipment for vacuum-assisted



aquifer testing is desirable, because such testing yields information that is directly relevant to the potential effectiveness of a full-scale DPE system at the site. However, this approach may be prohibitively expensive for smaller sites; in such cases, traditional aquifer testing (using groundwater extraction alone) may be used. Aquifer pumping tests are preferred over slug tests because slug tests only yield information regarding the local transmissivity (hydraulic conductivity times the thickness of the groundwater flow zone) in the immediate vicinity of the tested well, whereas pumping tests yield information regarding the transmissivity over a relatively wide area surrounding the pumped well. When properly conducted and analyzed, aquifer tests will yield reliable estimates of the relevant hydraulic parameters (transmissivity and storage coefficients) of the tested groundwater flow zone(s) that are targeted for remediation. These values should then be used in an appropriate groundwater model to simulate the potential groundwater extraction effectiveness under the applied vacuums achievable with a DPE system. In this way, the feasibility of the groundwater extraction portion of the DPE system can be properly assessed.

If the success of the DPE application is particularly dependent on biodegradation, relevant field and/or laboratory testing should be conducted. Chapter III on Bioventing describes several types of pilot-scale tests that can be performed to confirm the potential effectiveness of biodegradation.

## **Evaluation Of The DPE System Design**

---

Once you have verified that DPE is generally applicable to the site, you can scrutinize the design of the system. A pilot study that provides data used to design the full-scale DPE system is highly recommended. The CAP should include a discussion of the rationale for the design and a presentation of the conceptual engineering design. Detailed engineering design documents might also be included, depending on state requirements. Further detail about information to look for in the discussion of the design is provided below.

### **Rationale For The Design**

The primary basis for any subsurface remedial design is a definition of the volume of the subsurface targeted for active remediation (volume of attainment) and the cleanup levels or concentrations of constituents that must be achieved within the volume of attainment to protect human health and the environment. The cleanup levels may either be defined by state regulated "remedial action levels" or be determined on a site-

specific basis using transport modeling and risk assessment. Site characterization data must be used to determine what volumes of site soils and/or groundwater exceed the state action levels or site-specific, health-based cleanup levels. The CAP should clearly describe how the proposed DPE system is designed to meet the remedial action objectives. In addition, information such as the following should be included:

- *The Design Radius of Influence (ROI)* is the maximum distance from a vapor extraction well at which sufficient air flow can be induced to sustain acceptable rates of remediation (as dictated by the desired or required remediation time). The usefulness of the simple ROI concept is limited to certain site conditions (e.g., a single extraction well operating without air inlets or air-injection wells), and even when applicable, the task of establishing a meaningful ROI is not trivial. The ROI depends on many factors including the geometric configuration of extraction and injection wells, intrinsic permeability of the soil, soil moisture content, and desired remediation time. The ROI is best determined through field pilot studies, but it can be estimated from air flow modeling or other empirical methods. Generally, the design ROI can range from 5 feet (for fine-grained soils) to 100 feet (for coarse-grained soils) for a single well operating alone. For sites with stratified geology, radii of influence should be defined for each major soil type that occupies a significant portion of the chemically affected soil profile.
- For applications where the groundwater is shallow, ambient air is supplied readily through the land surface to the soils requiring treatment. In this case, the ROI can be used in a simple manner to determine the appropriate number and spacing of extraction wells. For applications in deeper treatment intervals, or treatment intervals that are effectively isolated from surface air supply, air inlet wells are required for effective remediation, and the simple ROI concept is not directly applicable. In such cases, subsurface air-flow stimulation is recommended to aid in properly designing a system of extraction and injection wells (or passive air inlets) that provides reasonably uniform air circulation throughout the targeted regions of the vadose zone.
- *Wellhead Vacuum* is the vacuum pressure that is required at the top of the vent well to produce the desired radius of vacuum influence in the soils. Required wellhead vacuums are usually determined with the aid of field pilot studies, and they typically range from 3 to 100 inches of water vacuum. Less permeable soils generally require higher wellhead vacuum pressures to produce reasonable influence radii of influence. It should be noted, however, that high vacuums can cause upwelling of the water table and occlusion of all or part of the extraction well screens.

- *Vapor Extraction Flow Rate* is the volumetric flow rate of soil vapor that will be extracted from each extraction well. Vapor extraction rate, radius of influence, and wellhead vacuum are all interdependent, (i.e., a change in the extraction rate will cause a change in wellhead vacuum and radius of influence). Appropriate vapor extraction flow rates are best determined from pilot studies, but they can be estimated using mathematical models and estimated values of the air-flow parameters such as effective air permeability and flow-zone thickness. The flow rate will contribute to the operational time requirements of the DPE system. Typical extraction rates range from 2 to 50 cubic feet per minute (cfm) per well.
- *Groundwater Extraction Rates* should, at a minimum, be sufficient to capture groundwater that has constituent concentrations that exceed applicable standards or that pose a threat to human health or the environment. Higher groundwater extraction rates may also be specified to produce greater water-table drawdowns and enhance the effectiveness of vadose zone remediation. The design of the groundwater extraction portion of the DPE system should be based on the results of aquifer testing and groundwater flow modeling. This is especially true when groundwater extraction is proposed from multiple groundwater flow zones, or when the objectives of the groundwater extraction include lowering the water table (dewatering).
- *Initial Constituent Vapor Concentrations* can be measured during pilot studies or estimated from soil gas samples or soil samples. They are used to estimate constituent mass removal rate and DPE operational time requirements, and to determine whether treatment of extracted vapors will be required prior to atmospheric discharge or reinfection (if allowed).

The concentration of constituents in the extracted vapor is typically much higher during system start up than during sustained, long-term operations. The higher initial vapor concentrations usually last only a few hours or days before dropping off significantly. Vapor treatment requirements may be greater during this early phase of remediation, compared to the long-term requirements.

- *Required Final Constituent Concentrations* in soils, or soil cleanup levels, may be defined by state regulations as “remedial action levels,” or they may be determined on a site-specific basis using fate and transport modeling and risk assessment. The required soil cleanup levels will determine what areas of the site require treatment and when DPE operation can be terminated.

- *Required Remedial Cleanup Time* may also influence the design of the system. The designer may reduce the spacing of the extraction wells to increase the rate of remediation to meet cleanup deadlines or client preferences, as required.
- *Soil Volume To Be Treated* is determined by state action levels or a site-specific risk assessment using site characterization data for the soils.
- *Pore Volume Calculations* are used along with extraction flow rate to determine the pore volume exchange rate. The exchange rate is calculated by dividing the pore space within the treatment zone by the design extraction rate (for vapor and groundwater separately). The pore space within the treatment zone is calculated by multiplying the soil porosity by the volume of soil to be treated. Some literature suggests that one pore volume of soil vapor be extracted at least daily for effective remedial progress if volatilization is intended to be the primary removal mechanism.

You can calculate the time required to exchange one pore volume of soil vapor using the following equation:

$$E = \frac{\epsilon V}{Q}$$

where: E = pore volume exchange time (hr)  
 $\epsilon$  = soil porosity (m<sup>3</sup> vapor / m<sup>3</sup> soil)  
 V = volume of soil to be treated (m<sup>3</sup> soil)  
 Q = total vapor extraction flow rate (m<sup>3</sup> vapor / hr)

- *Discharge Limitations And Monitoring Requirements* are usually established by state regulations, but they must be considered by designers of a DPE system to ensure that monitoring ports are included in the system hardware. Discharge limitations imposed by state air quality regulations will determine the offgas treatment requirements.
- *Site Construction Limitations*, such as building locations, utilities, buried objects, and residences must be identified and considered in the design process.

### **Components Of A DPE System**

Once the design basis is defined, the design of the DPE system can be developed. A typical DPE system design will include the following components and information:

- Extraction well orientation, placement, and construction details
- Manifold piping
- Vapor pretreatment (if necessary)
- Vapor treatment (if necessary)
- Blower selection
- Instrumentation and control design
- Optional DPE components
- Surface seals
- Injection wells

Exhibits XI-13 and XI-14 are schematic diagrams of single-pump and dual-pump DPE systems, respectively.

The following subsections provide guidance for selecting the appropriate system configuration, standard system components, and additional system components to adequately address petroleum contaminated soils at a particular UST site.

### ***Extraction Wells***

**Well Orientation.** DPE systems generally use vertical extraction wells, although horizontal wells can be used for air injection and/or for nutrient addition to enhance biodegradation, if needed.

**Well Placement And Number Of Wells.** This design element is critical to the effectiveness of a DPE system. For complex sites, numerical modeling should be used to simulate subsurface vapor flow and groundwater flow. For simpler, shallow groundwater sites, you can determine the number and location of extraction wells by using several methods. In the first method, divide the area of the site requiring treatment by the area of influence for a single well to obtain the total number of wells needed.

Then, space the wells evenly within the treatment area to provide areal coverage so that the areas of influence cover the entire area of contamination.

$$\text{Area of influence for a single well} = \pi \cdot (\text{ROI})^2$$

$$\text{Number of wells needed} = \frac{\text{Treatment area (m}^2\text{)}}{\text{Area of influence for single extraction well (m}^2\text{/well)}}$$

This approximation method will work reasonably well in cases where ambient air is readily supplied to the extraction wells through the affected soils from the land surface. When there is no significant airflow from the land surface downward through the treatment zone,

**Exhibit XI-13  
Schematic of Single Pump DPE System**

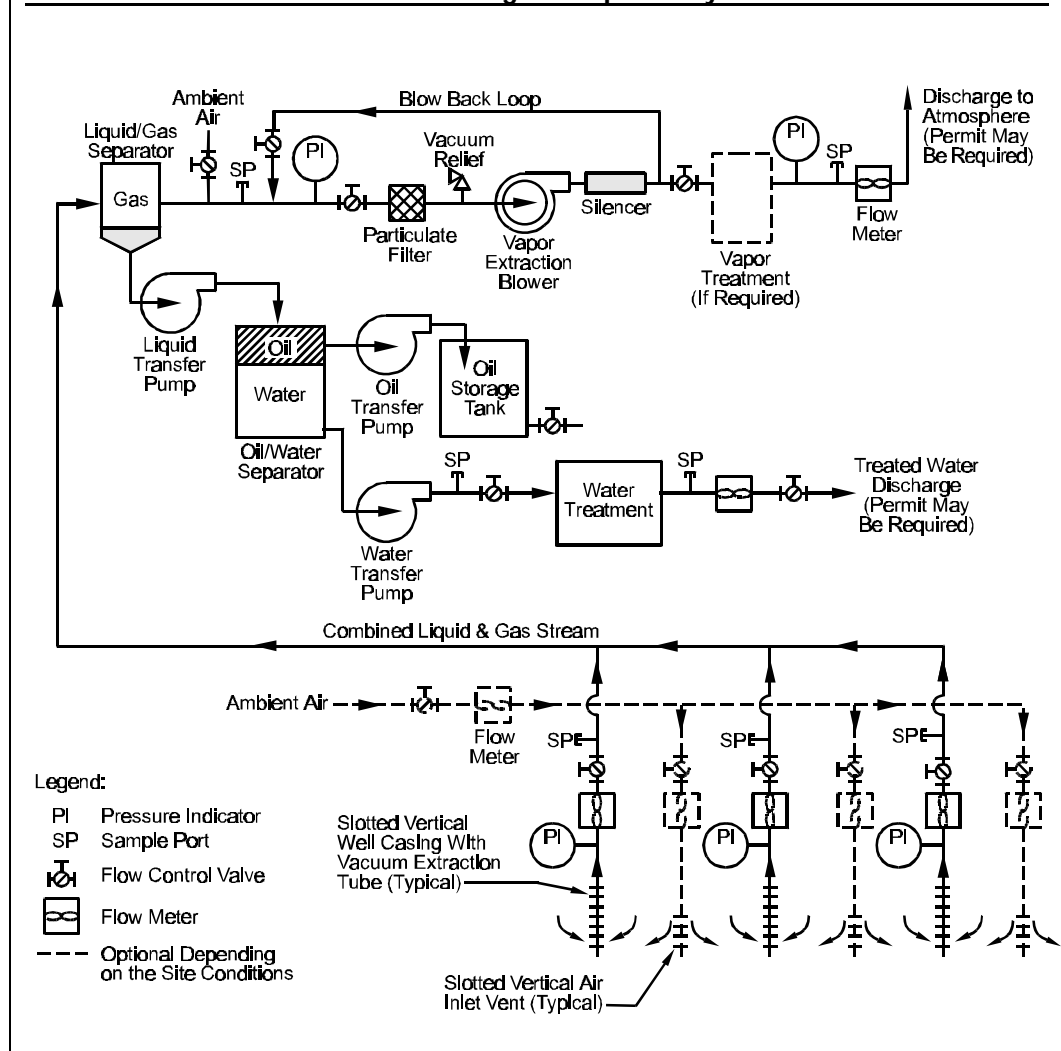

approximately half of the evenly spaced wells specified should be air injection wells or passive air inlets.

It is important to note the potential for "short circuiting" of vertical air flow downward from the land surface in the immediate vicinity of an extraction well. Such short circuiting leads to ineffective remediation because the resulting air-flow circulation pattern only affects a small volume of soil surrounding the extraction well. Short circuiting may occur at system startup, or it may begin to occur after a DPE system has been in operation for some time. Short circuiting at initial system startup usually results from placing screened intervals at shallow depths in media with high effective vertical air permeabilities. This allows a relatively large volume of air to enter near the extraction well, reducing the well's effective radius of influence. The potential for this problem can

**Exhibit XI-14  
Schematic of Multi-Pump DPE System**

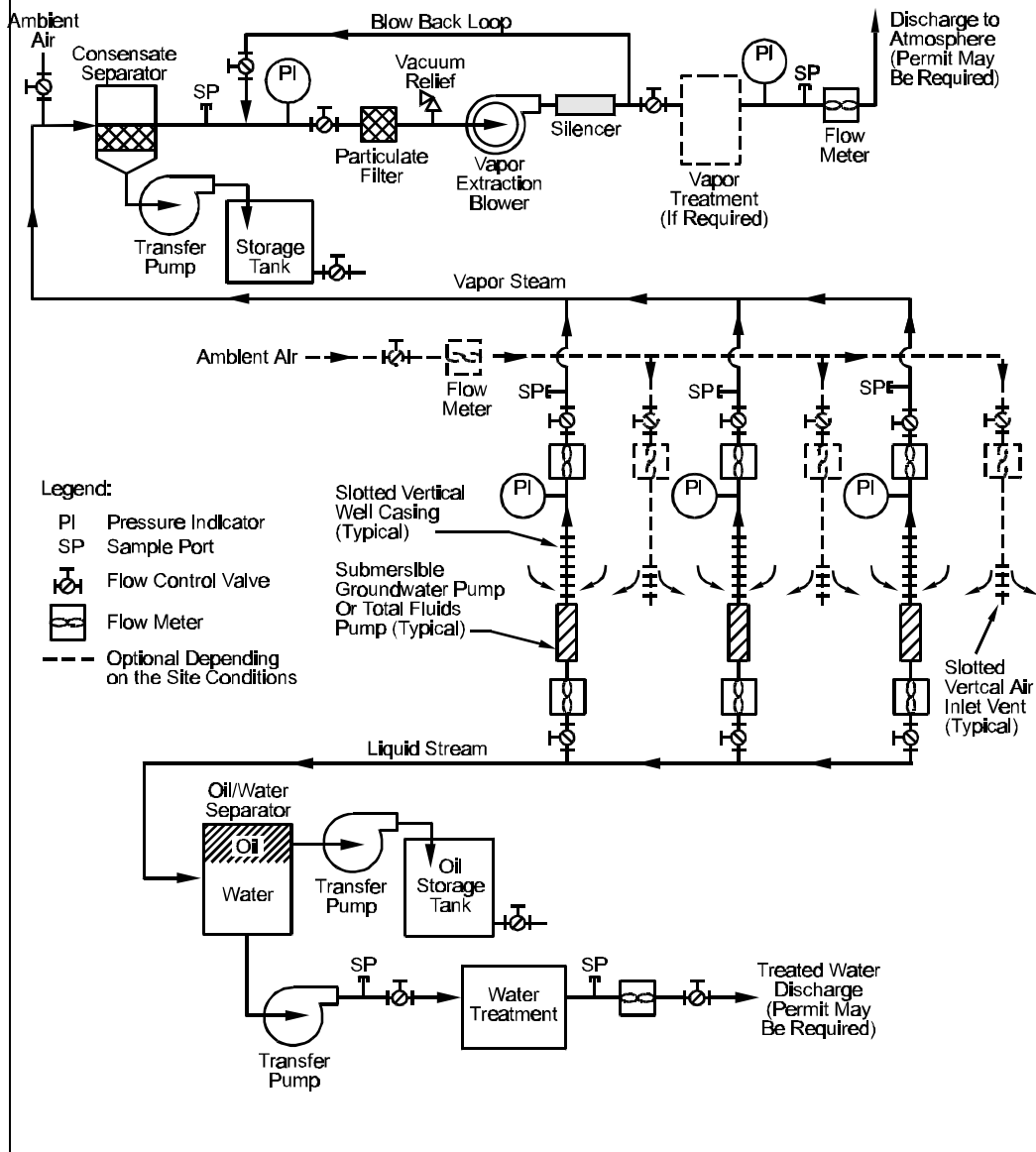

usually be assessed by conducting field testing, as previously discussed, and engineered surface seals may be used to overcome this type of problem. Short circuiting can likewise be caused by improper sealing of the well boring annulus during the well construction. In such cases, the well must be carefully sealed or replaced with a well of more air-tight design.

The potential for short circuiting after a period of sustained operations can be difficult to predict based on the results of a short field test. Short circuiting that develops after a period of system operation is

usually caused by a significant increase in effective vertical air-flow permeability due to the drainage of water and/or product from the soil pores, which increases the air-filled porosity of the aquifer matrix and hence the effective air permeability. Adequate monitoring systems are therefore required to detect changes in the system vacuum and/or air-flow rates over time.

In the second method used to estimate the number of wells needed, determine the total extraction flow rate required to exchange the soil pore volume within the treatment area in 1 to 7 days. Determine the number of wells required by dividing the total extraction flow rate needed by the flow rate achievable with a single well.

$$\text{Number of wells needed} = \frac{\epsilon V/t}{q}$$

where:  $\epsilon$  = soil porosity ( $\text{m}^3$  vapor /  $\text{m}^3$  soil)  
 $V$  = volume of soil in treatment area ( $\text{m}^3$  soil)  
 $q$  = vapor extraction rate from single extraction well  
( $\text{m}^3$  vapor/hr)  
 $t$  = pore volume exchange time (hours)

Similar calculations can be used for evaluating groundwater extraction. Consider the following additional factors in determining well spacing.

- Use closer well spacing in areas of high contaminant concentrations to increase mass removal rates.
- If a surface seal exists or is planned for the design, space the wells slightly farther apart because air is drawn from a greater lateral distance and not directly from the surface. However, be aware that the presence of a surface seal and the increase in extraction well spacing increases the need for air injection wells.
- At sites with stratified soils, wells that are screened in strata with low intrinsic permeabilities should be spaced more closely than wells that are screened in strata with higher intrinsic permeabilities. Well spacing may be irregular.

**Well Construction.** Typical single-pump and dual-pump DPE extraction wells are shown in Exhibits XI-3 and XI-4, presented earlier. Extraction wells are similar in construction to monitoring wells and are drilled using the same techniques. Extraction wells are usually constructed of polyvinyl chloride (PVC) casing and screening. Extraction well diameters typically range from 2 to 8 inches, depending on flow rates and depth; a 4-inch diameter is most common.



Extraction wells are constructed by placing the casing and screen in the center of a borehole. Filter pack material is placed in the annular space between the casing/screen and the walls of the borehole. The filter pack material extends 1 to 2 feet above the top of the well screen; a 1 to 2 foot thick bentonite seal is placed above the filter pack. Cement-bentonite grout seals the remaining space up to the land surface. Filter pack material and screen slot size must be consistent with the grain size of the surrounding soils.

The location and length of the well screen in vertical extraction wells can vary and should be based on the depth to groundwater, the stratification of the soil, and the location and distribution of contaminants. The bottom of the screened interval must be sufficiently deep to allow for the maximum anticipated groundwater drawdown.

- At a site with homogeneous soil conditions, ensure that the well is screened throughout the contaminated zone. A deeper well helps to ensure remediation of the greatest amount of soil during seasonal low groundwater conditions.
- At a site with stratified soils or Ethology, check to see that an adequate number of wells have been screened within the lower permeability zones, as well as the higher permeability zones, because these zones are generally more difficult to remediate.

### ***Manifold Piping***

Manifold piping connects the extraction wells to the surface blower. Piping can either be placed above or below grade depending on site operations, ambient temperature, and local building codes. Below-grade piping is most common and is installed in shallow utility trenches that lead from the extraction wellhead vault(s) to a central equipment location. The piping can either be manifolded in the equipment area or connected to a common vacuum main that supplies the wells in series, in which case flow control valves are sited at the wellheads. Piping to the well locations should be sloped toward the well so that condensate or groundwater that is entrained with the air flow stream will flow back toward the well.

### ***Vapor Pretreatment***

Extracted vapor can contain condensate, entrained groundwater, and particulates that can damage blower parts and inhibit the effectiveness of downstream treatment systems. In order to minimize damage, vapors are usually passed through a moisture separator and a particulate filter

prior to entering the blower. Check the CAP to verify that these elements have been included in the design.

### ***Vapor Treatment***

Look for vapor treatment systems in the DPE design if pilot study data indicate that extracted vapors will contain VOC concentrations in excess of established air quality limits. Available options for vapor treatment include granular activated carbon (GAC), catalytic oxidation, or thermal oxidation.

GAC is a popular choice because of its simplicity and effectiveness. Catalytic oxidation is often used, however, when the contaminant mass loading rate is expected to be too high to make GAC economical, and when concentrations are at or below 20 percent of their lower explosive limit (LEL). A thermal oxidizer may be employed when concentrations of chemical constituents are expected to be sustained at levels greater than 20 percent of their LELs.

### ***Blower Selection***

The type and size of blower selected should be based on (1) the vacuum required to achieve design vacuum pressure at the vent wellheads (including upstream and downstream piping losses, and (2) the total flow rate required. The flow rate requirement should be based on the sum of the flow rates from the contributing vapor extraction wells. In applications where explosive concentrations of hydrocarbon vapors can collect, be sure the CAP specifies blowers with explosion-proof motors, starters, and electrical systems. Exhibit XI- 15 depicts the performance curves for the three basic types of blowers that can be used in a DPE system.

- *Centrifugal blowers* (such as squirrel-cage fans) should be used for high-flow, low-vacuum applications. Centrifugal blowers are only applicable for dual-pump DPE systems, because higher vacuums are required for single-pump DPE systems.
- *Regenerative and turbine* blowers should be used when a moderately high vacuum is needed.
- *Rotary lobe* and other positive displacement blowers should be used when a very high vacuum is needed.

Liquid ring vacuum pumps are also commonly used for DPE applications in very low permeability environments where high vacuums are required.

**Exhibit XI-15  
Performance Curves For Three Types Of Blowers**

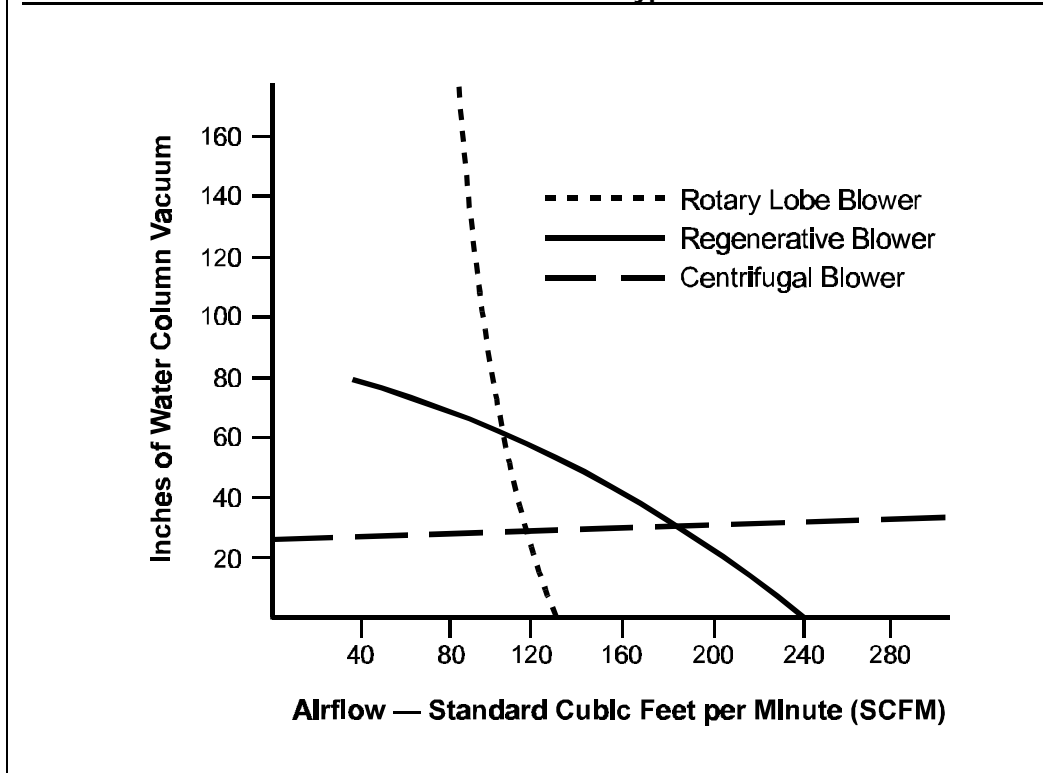

Note: Centrifugal blower type shown is a New York model 2004A at 3500 rpm. Regenerative blower type shown is a Rotron model DR707. Rotary lobe blower type shown is a M-D Pneumatics model 3204 at 3000 rpm.

From "Guidance for Design, Installation and Operation of Soil Venting Systems." Wisconsin Department of Natural Resources, Emergency and Remedial Response Section, PUBL-SW 185-93, July 1993.

### ***Instrumentation and Controls***

The parameters typically monitored in an DPE system include:

- Pressure (or vacuum)
- Air/vapor flow rate
- Groundwater extraction rates
- Carbon dioxide and/or oxygen concentrations in extracted air (to monitor biodegradation)
- Contaminant mass removal rates
- Temperature

The equipment in a DPE system used to monitor these parameters provides the information necessary to make appropriate system adjustments and track remedial progress. The monitoring equipment in a DPE system enables you to control each component of the system. Exhibit XI- 16 lists typical monitoring and control equipment for a DPE

system, where each of these pieces of monitoring equipment should be placed, and the types of equipment that are available.

| <b>Exhibit XI-16<br/>Monitoring And Control Equipment</b>        |                                                                                                                                                                                             |                                                                                                                                                                               |
|------------------------------------------------------------------|---------------------------------------------------------------------------------------------------------------------------------------------------------------------------------------------|-------------------------------------------------------------------------------------------------------------------------------------------------------------------------------|
| <b>Monitoring Equipment</b>                                      | <b>Location In System</b>                                                                                                                                                                   | <b>Example Of Equipment</b>                                                                                                                                                   |
| Flow meter                                                       | <ul style="list-style-type: none"> <li>○ At each wellhead</li> <li>○ Manifold to blower</li> <li>○ Blower discharge</li> </ul>                                                              | <ul style="list-style-type: none"> <li>○ Pitot tube</li> <li>○ In-line rotameter</li> <li>○ Orifice plate</li> <li>○ Venturi or flow tube</li> </ul>                          |
| Vacuum gauge                                                     | <ul style="list-style-type: none"> <li>○ At each well head or manifold branch</li> <li>○ Before and after filters upstream of blower</li> <li>○ Before and after vapor treatment</li> </ul> | <ul style="list-style-type: none"> <li>○ Manometer</li> <li>○ Magnehelic gauge</li> <li>○ Vacuum gauge</li> </ul>                                                             |
| Vapor temperature sensor                                         | <ul style="list-style-type: none"> <li>○ Manifold to blower</li> <li>○ Blower discharge (prior to vapor treatment)</li> </ul>                                                               | <ul style="list-style-type: none"> <li>○ Bi-metal dial-type thermometer</li> </ul>                                                                                            |
| Sampling port                                                    | <ul style="list-style-type: none"> <li>○ At each well head or manifold branch</li> <li>○ Manifold to blower</li> <li>○ Blower discharge</li> </ul>                                          | <ul style="list-style-type: none"> <li>○ Hose barb</li> <li>○ Septa fitting</li> </ul>                                                                                        |
| Vapor sample collection equipment (used through a sampling port) | <ul style="list-style-type: none"> <li>○ At each well head or manifold branch</li> <li>○ Manifold to blower</li> <li>○ Blower discharge</li> </ul>                                          | <ul style="list-style-type: none"> <li>○ Tedlar bags</li> <li>○ Sorbent tubes</li> <li>○ Sorbent canisters</li> <li>○ Polypropylene tubing for direct GC injection</li> </ul> |
| <b>Control Equipment</b>                                         |                                                                                                                                                                                             |                                                                                                                                                                               |
| Flow control valves                                              | <ul style="list-style-type: none"> <li>○ At each well head or manifold branch</li> <li>○ Dilution or bleed valve at manifold to blower</li> </ul>                                           | <ul style="list-style-type: none"> <li>○ Ball valve</li> <li>○ Gate/globe valve</li> <li>○ Butterfly valve</li> </ul>                                                         |

### Optional DPE Components

Additional DPE system components might be required when certain site conditions exist or pilot studies dictate they are necessary. These components include land surface seals and injection wells. Each of these system components is discussed on the following pages.

## ***Land Surface Seals***

Land surface seals might be included in an DPE system design in order to prevent surface water infiltration that can reduce air flow rates, reduce fugitive emissions, and increase the lateral extent of air flow to increase the volume of soil being treated. These results are accomplished because surface seals force fresh air to be drawn from a greater distance from the extraction well. If a surface seal is used, lower pressure gradients may exist and decreased flow velocities will result unless a higher vacuum is applied to the extraction well, or additional air injection wells are used.

Surface seals or caps should be selected to match the site conditions and regular business activities at the site. Options include high density polyethylene (HDPE) liners (similar to landfill liners), clay or bentonite seals, or concrete or asphalt paving. Existing covers (e.g., pavement or concrete slabs) might not be effective as an air-flow barrier if they are constructed with a porous subgrade material.

## ***Injection Wells***

Air injection wells are used to enhance air flow rates from the extraction wells by providing an active or passive air source to the subsurface. These wells are often used at sites that are covered with an impermeable cap (e.g., pavement or buildings) because the cap restricts direct air flow to the subsurface. They may also be used to help reduce short-circuiting of air flow in the subsurface. In addition, air injection is used to eliminate potential stagnation zones (areas of no flow) which can exist between extraction wells.

Air injection wells are similar in construction to extraction wells, and they may be operated in either passive or active mode. Active injection wells force compressed air into soils. Passive injection wells, or inlets, simply provide a pathway that helps extraction wells draw ambient air into the subsurface. Air injection wells should be placed to eliminate stagnation zones, but should not force contaminants toward areas from which they cannot be recovered (i.e., away from the influence areas of the systems' extraction wells).

## **Evaluation Of Operation And Monitoring Plans**

---

Make sure that a system operation and monitoring plan has been developed for both the system start-up phase and for long-term operations. Operations and monitoring are necessary to ensure that system performance is optimized and contaminant mass removal is tracked. When significant biodegradation occurs in the subsurface, mass

removal cannot be directly measured by simply monitoring extracted liquid and vapors. Both constituent concentrations and carbon dioxide concentrations (to measure microbial respiration) should be monitored in the extracted vapor stream. Dissolved constituent concentrations in the extracted groundwater and the quantity of petroleum product collected must be monitored to assess constituent mass removal.

### **Start-Up Operations**

The start-up phase of operations for single-pump DPE systems will include about 7 to 10 days of adjustments in the vacuum pump settings and the depth of the extraction tube inlet. Multi-pump systems will require a similar period of adjusting the valves and pumps for the separate groundwater and air extraction systems. The start-up phase should also include manifold valving adjustments. These adjustments should balance flow between the wells within the system. To optimize DPE effectiveness, flow measurements, pressure or vacuum readings, carbon dioxide concentrations, oxygen concentrations, and volatile organic compound (VOC) concentrations should be recorded daily from each extraction well, from the manifold, and from the effluent stack during the start up adjustment period. These measurement can be used to decide how to best operate the system. Nutrient delivery (if needed to enhance biodegradation) should not be performed until after start-up operations are complete.

### **Long-Term Operations**

Long-term monitoring should consist of flow-balancing, flow and pressure measurements, and vapor concentration readings. Measurements are commonly made at weekly or biweekly intervals for the duration of the system operational period.

Exhibit XI-17 provides a brief synopsis of system monitoring requirements.

### **Remediation Progress Monitoring**

Monitoring the performance of the DPE system in reducing contaminant concentrations in soils is necessary to track the progress of remediation. Since concentrations of petroleum constituents may be reduced due to both volatilization and biodegradation, both processes should be monitored in order to track their cumulative effect. Constituent mass extraction can be tracked and calculated by multiplying the vapor concentrations measured in the extraction manifold by the extraction air flow rate and adding the rate of petroleum

**Exhibit XI-17  
System Monitoring Recommendations**

| Phase                   | Monitoring Frequency | What To Monitor                                                                                                                                                                                                                                                                                          | Where To Monitor                                                                                                                                                               |
|-------------------------|----------------------|----------------------------------------------------------------------------------------------------------------------------------------------------------------------------------------------------------------------------------------------------------------------------------------------------------|--------------------------------------------------------------------------------------------------------------------------------------------------------------------------------|
| Start-up<br>(7-10 days) | At least daily       | <ul style="list-style-type: none"> <li><input type="radio"/> Flow</li> <li><input type="radio"/> Vacuum readings</li> <li><input type="radio"/> Vapor concentrations</li> <li><input type="radio"/> Carbon dioxide</li> <li><input type="radio"/> Oxygen</li> </ul>                                      | <ul style="list-style-type: none"> <li><input type="radio"/> Extraction vents</li> <li><input type="radio"/> Manifold</li> <li><input type="radio"/> Effluent stack</li> </ul> |
| Remedial<br>(ongoing)   | Weekly to bi-weekly  | <ul style="list-style-type: none"> <li><input type="radio"/> Flow-balancing</li> <li><input type="radio"/> Flow</li> <li><input type="radio"/> Vacuum</li> <li><input type="radio"/> Vapor concentrations</li> <li><input type="radio"/> Carbon dioxide</li> <li><input type="radio"/> Oxygen</li> </ul> | <ul style="list-style-type: none"> <li><input type="radio"/> Extraction vents</li> <li><input type="radio"/> Manifold</li> <li><input type="radio"/> Effluent stack</li> </ul> |

product recovery and dissolved aqueous phase recovery. The constituent mass that is biodegraded is more difficult to quantify but can be estimated from monitoring data on carbon dioxide and oxygen concentrations in the extracted air stream. The quantities of petroleum hydrocarbons degraded can then be estimated stoichiometrically (see Chapter III, Bioventing).

Remediation progress of DPE systems typically exhibits asymptotic behavior with respect to the rates of recovery of free product and groundwater, and a reduction in vapor concentration and the overall rate of mass removed. (See Exhibit XI-18.) When asymptotic behavior begins to occur, the operator should evaluate alternatives that may increase DPE effectiveness (e.g., altering the subsurface airflow patterns by changing airflow rates). Other more aggressive steps to renew remediation effectiveness can include installing additional injection wells or extraction wells. If very low effluent concentrations persist, extraction flow rates may be reduced significantly, or the system may be operated in a pulsed mode (although pulsed operation is generally less efficient than operating at a very low, sustained extraction rate). Pulsing involves the periodic shutdown and startup of extraction wells to allow the subsurface environment to come to equilibrium (shutdown) before beginning to extract vapors again.

If asymptotic behavior persists for periods greater than about 6 months, the concentration rebound remains small following periods of system shutdown, and residual contamination levels are at or below regulatory limits, termination of operations may be appropriate. If not,

Exhibit XI-18  
Relationship Between Concentration Reduction And Mass Removal

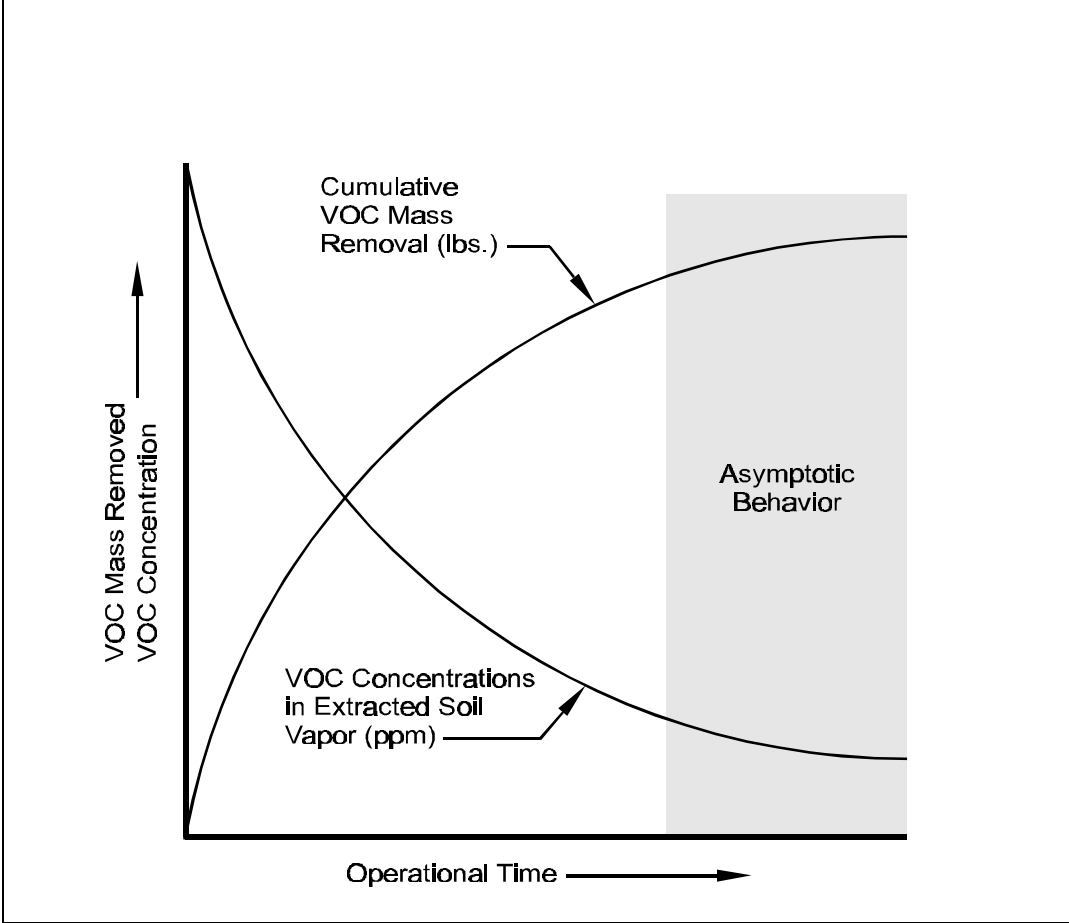

operation of the system as a bioventing system with reduced vacuum and air flow may be effective way to complete remediation.



## References

---

- Blake, S.B., and N.M. Gates. "Vacuum Enhanced Hydrocarbon Recovery: A Case Study," *in Proceedings of NWWA/API Conference on Petroleum Hydrocarbons and Organic Chemicals in Ground Water: Prevention, Detection, and Restoration*. November 12-14, Houston, Texas, p. 709-721, 1986.
- Blake, S., B. Hockman, and M. Martin. "Applications of Vacuum Dewatering Techniques to Hydrocarbon Remediation," *in Proceedings of NWWA/API Conference on Petroleum Hydrocarbons and Organic Chemicals in Ground Water: Prevention, Detection, and Restoration*. October 31 - November 2, Houston, Texas, p. 211-226, 1990.
- Bruce, L., B. Hockman, R. James-Deanes, J. King, and D. Laws. "Vacuum Recovery Barrier Wall System Dewateres Contaminated Aqulfer: A Solution Based on Proper Evaluation of Hydrogeologic Parameters," *in Proceedings of the NGWA/API Conference on Petroleum Hydrocarbons and Organic Chemicals in Ground Water: Prevention, Detection, and Restoration*. November 4-6, Houston, Texas, p. 303-311, 1992.
- Hajali, P.A., and W.F. Revely, III. *Process and Apparatus for Groundwater Extraction Using a High Vacuum Process*. U.S. Patent No. 5,172,764, December 22, 1992.
- Hess, R.E., A.A. Hooper, S.R. Morrow, D.J. Walker, and E. Zimmerman. *Process for Two Phase Vacuum Extraction of Soil Contaminants*. U.S. Patent No. 5,050,676, September 24, 1991.
- Hess, R.E., A.A. Hooper, S.R. Morrow, D.J. Walker, and E. Zimmerman. *Apparatus for Two Phase Vacuum Extraction of Soil Contaminants*. U.S. Patent No. 5,197,541, March 30, 1993.
- Johnson, R.L., Bagby, W., Matthew, P., and Chien, C.T. "Experimental Examination of Integrated Soil Vapor Extraction Techniques," *in Proceedings of Petroleum Hydrocarbons and Organic Chemicals in Ground Water: Prevention, Detection, and Restoration*. National Ground Water Association, November, 1992.
- Powers, J.P. *Construction Dewatering, A Guide to Theory and Practice*. Wiley Interscience, 1981.
- U.S. Air Force. *Technology Profile: Vacuum-Mediated LNAPL Free Product Recovery/Bioremediation (Bioslurper)*. Air Force Center for Environmental Excellence, March 1994.

# Checklist: Can Dual-Phase Extraction Be Used At This Site?

---

This checklist can help you evaluate the completeness of the CAP and to identify areas that require closer scrutiny. As you go through the CAP, answer the following questions. If the answer to several questions is no, you should request additional information to determine if DPE will accomplish cleanup goals at the site:

## 1. Site Characteristics

**Yes No**

- Are the soil and aquifer media intrinsic permeabilities greater than  $10^{-12}$  cm<sup>2</sup>?
- Is the soil free of impermeable layers or other conditions that would disrupt air flow?
- Is the soil moisture in the unsaturated zone less than or equal to 85 percent of saturation?
- Is depth to groundwater at least three feet?

## 2. Constituent Characteristics

**Yes No**

- Are constituent vapor pressures greater than 0.5 mm Hg, boiling points less than 300°C, and Henry's law constants greater than 100 atm?
- Are the chemical sorptive capacities of the constituents present sufficiently low?

## 3. Evaluation Of The DPE System Design

**Yes No**

- Does the radius of influence (ROI) for the proposed extraction wells fall within the range of 5 to 100 feet?
- Has the ROI been calculated for each soil type at the site?

- For more complex sites with multiple treatment depth intervals and/or the need for multiple extraction wells, was subsurface airflow modeling conducted to determine well placement?
- Is wellhead vacuum determined from field pilot studies and between 3 and 100 inches of water?
- Is vapor extraction flow rate between 2 and 50 cfm per well?
- Are groundwater extraction rates sufficient to capture groundwater with constituent concentrations above cleanup goals?
- Will initial constituent vapor concentrations be monitored?
- Are required final constituent concentrations specified?
- Is a specified cleanup time required?
- Is soil volume to be treated estimated?
- Is the pore volume exchange rate calculated?
- Are discharge limits specified?
- Were site construction limitations considered?
- Is the well density appropriate, given the total area to be cleaned up and the radius of influence of each well?
- Is manifold piping design addressed and do extraction pipes slope toward the wells?
- Is vapor pretreatment specified?
- Is vapor treatment included, if warranted based on treatability study?
- Is the blower selected appropriate for the desired vacuum conditions?

- Are appropriate instrumentation and controls specified, including means to monitor pressure (or vacuum), air/vapor flow rate, groundwater extraction rates, carbon dioxide and/or oxygen concentrations in extracted air, contaminant concentrations in extracted air, and temperature.

#### **4. Optional DPE Components**

**Yes No**

- Are land surface seals proposed?
- Are air injection or passive inlet wells proposed and are they appropriate to the site?

#### **5. Operation And Monitoring Plans**

**Yes No**

- Does the CAP propose daily monitoring for at least 1 week of flow measurements, constituent concentrations, vacuum readings, and carbon dioxide and oxygen concentrations?
- Does the CAP propose weekly to biweekly ongoing monitoring of these same parameters?