



Fuel Displacement & CO2 Benefits of Vehicle Electrification



Al Weverstad
Executive Director Public Policy
General Motors Corporation

Electrification enables ...

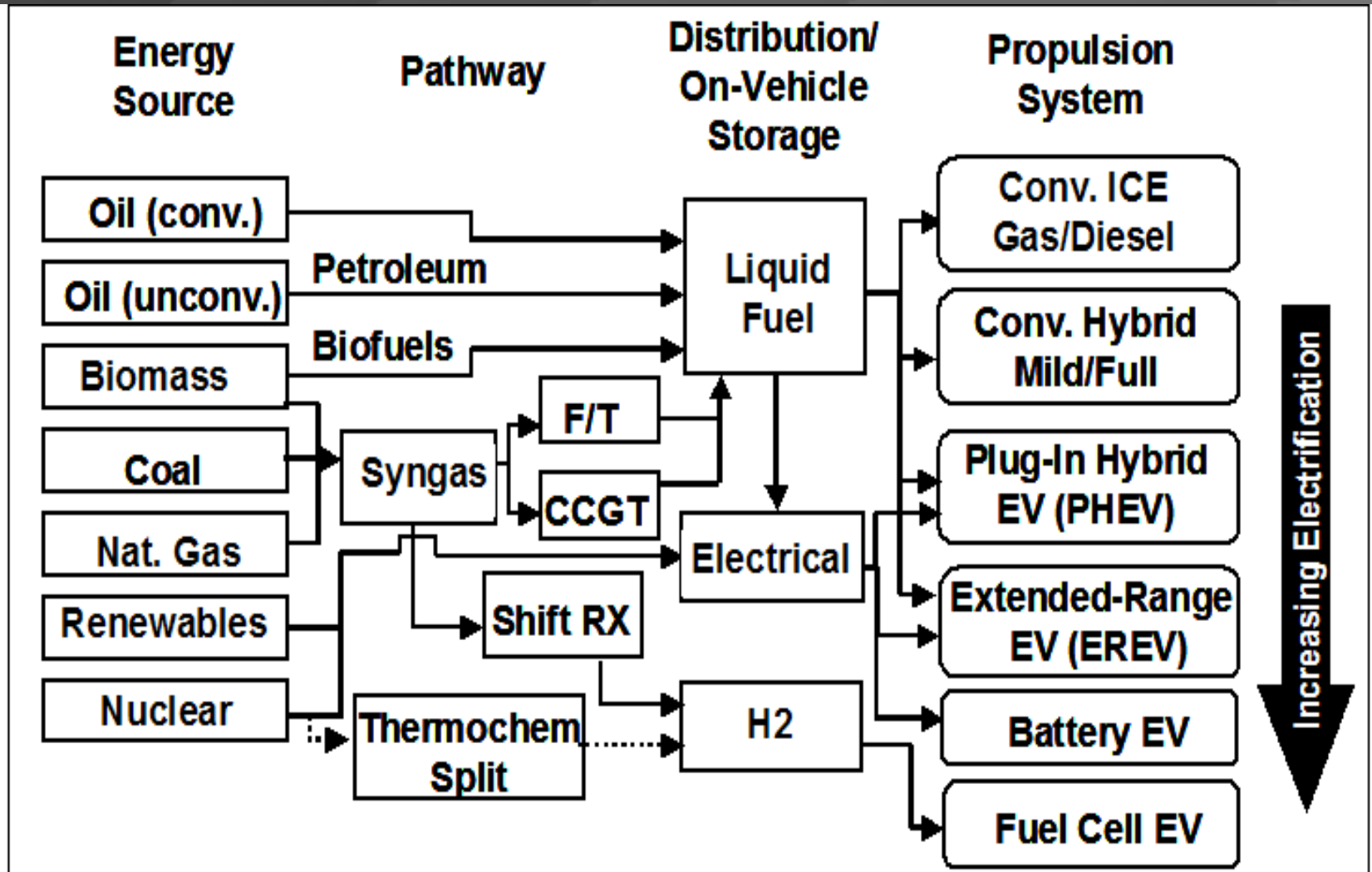

Important Questions

- What are the CO₂ effects of electrically powered transportation?
- How do PHEV compare with E-REVs for Petroleum displaced and for CO₂ generated?
- How does fleet petroleum consumption and CO₂ generation vary with battery pack size?
- How useful are multiple charges per day?
- How useful is higher power charging?

Vehicle Types By Attribute

Vehicle Type	Electric Power	Onboard Electric Storage	Grid Recharge	Electric Driving Capability	Preferential Electric Driving	Range Limit
Mild HEV	low	low	no	no	no	Gasoline
Full HEV	med	low	no	very limited	no	Gasoline
PHEV	med	med	yes	Urban Only	no	Gasoline + Battery
E-REV	high	high	yes	Full	yes	Gasoline + Battery
BEV	high	highest	yes	yes	yes	Battery

Vehicle Type Characterized by Energy Use

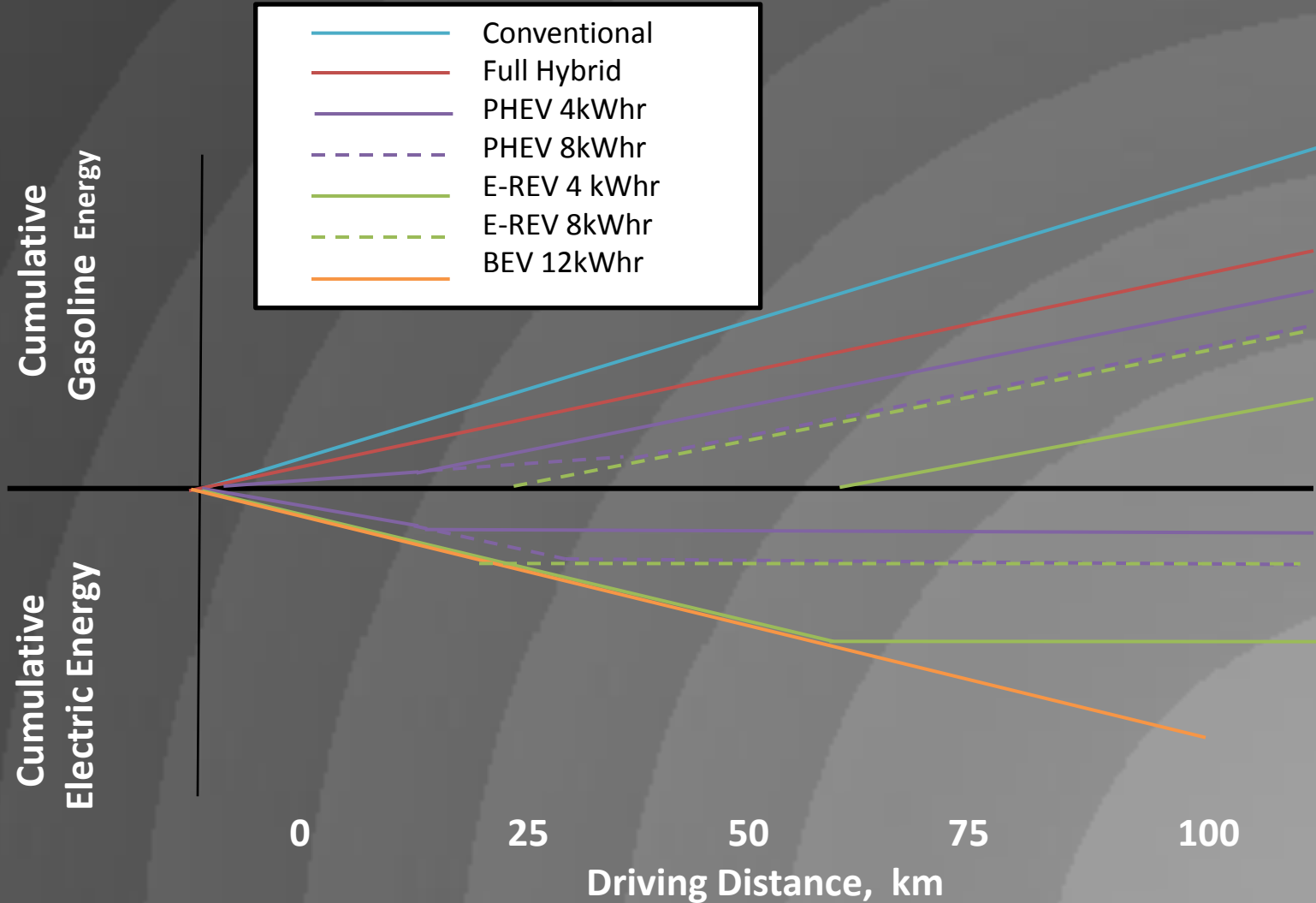

Studies of US Vehicle Use

- Two Major Populations Studied:
 - Southern California Association of Governments Regional Travel Survey, 2003
 - Speed vs. time of day, every second, aggregated days, 621 drivers
 - Basis of single charge per day study 2007
 - National Household Travel Survey, 2001
 - Vehicle location vs. arrival times, several weeks, separated days, >50,000 vehicles, >200,000 travel days
 - Basis of multiple charge per day studies

Analysis Study Vehicles Normalized



Based upon a 2009 Malibu, Full Hybrid, PHEV and E-REV was constructed. All achieve approximately 36 mpg charge sustaining FE on US Schedules

	Conventional or HEV	PHEV	E-REV
Charge Sustaining Fuel Economy		36 [mpg] 6.53 [l/100 km]	
Charge Decreasing Electrical Energy Consumption [kw-hr/mile]	n/a	0.350 [kw-hr/mi] 0.2175 [kw-hr/km]	
Charge Decreasing Energy Split	n/a	0.7	1.0

ZEV Power and Speed

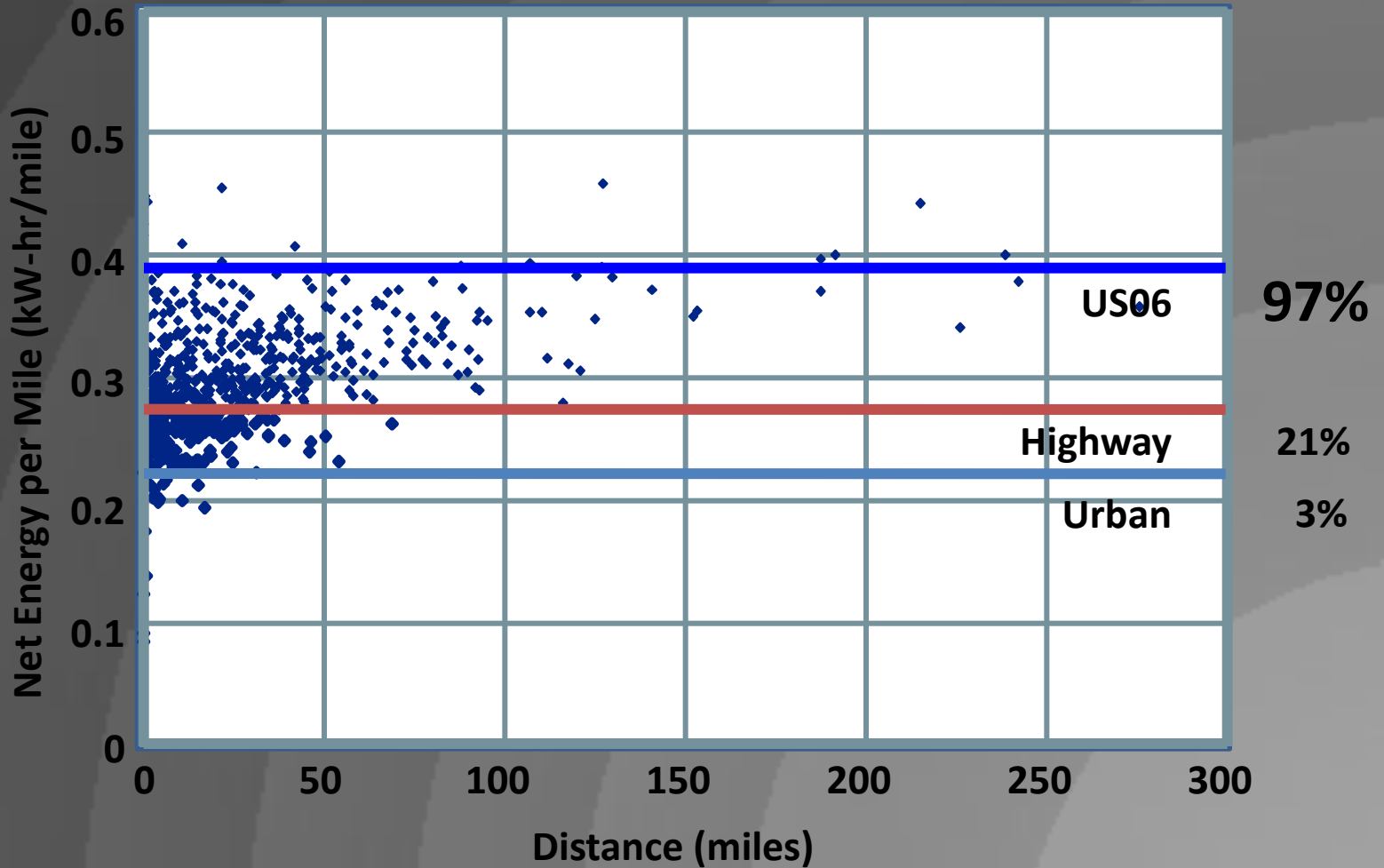

Mid-Sized Vehicle Simulated with
SCAG Regional Transportation Survey Data

Examining the “Average Driver”

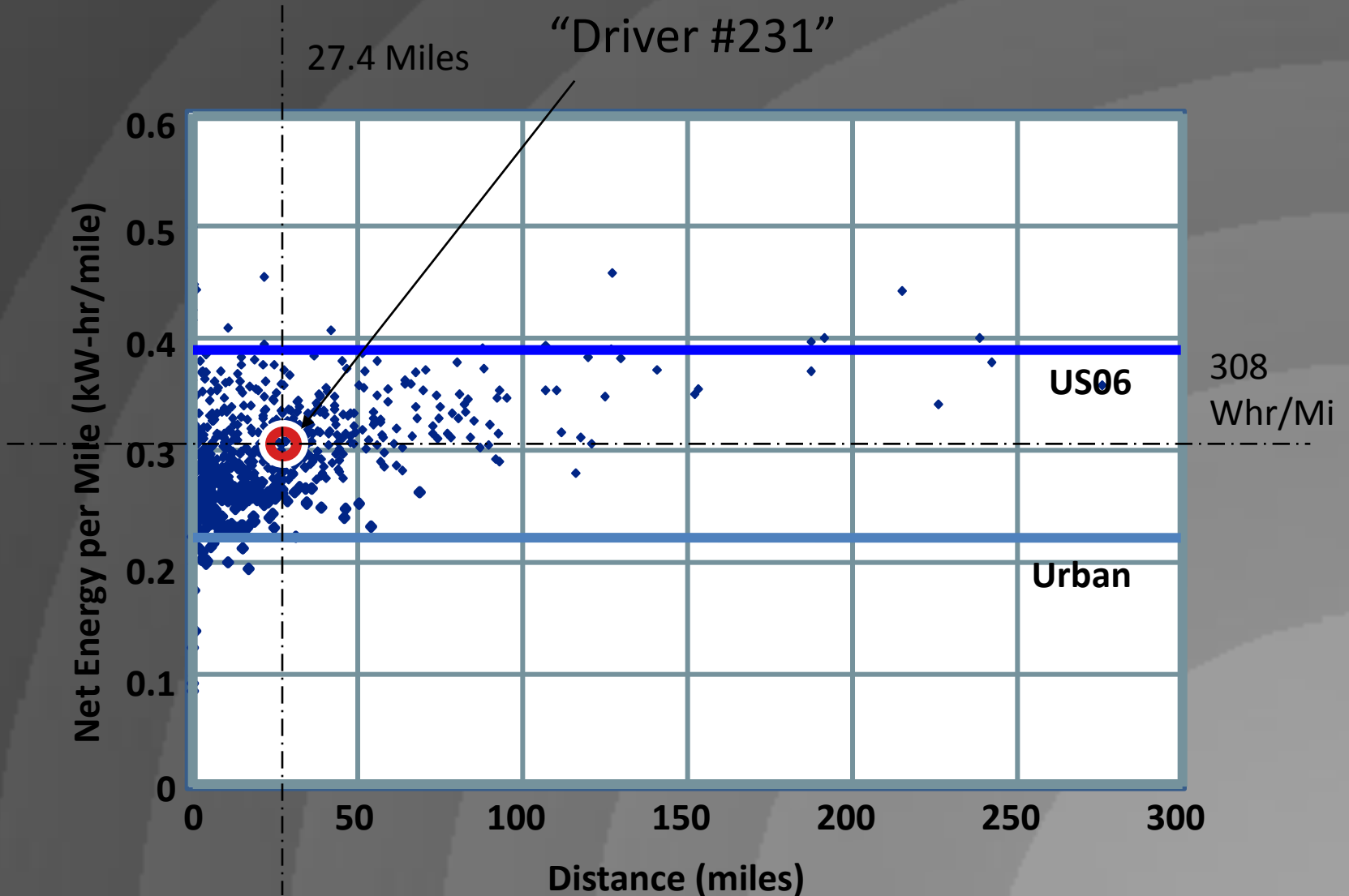

Mid-Sized Vehicle Simulated with SCAG Regional Transportation Survey Data

Driver #231's Driving Day

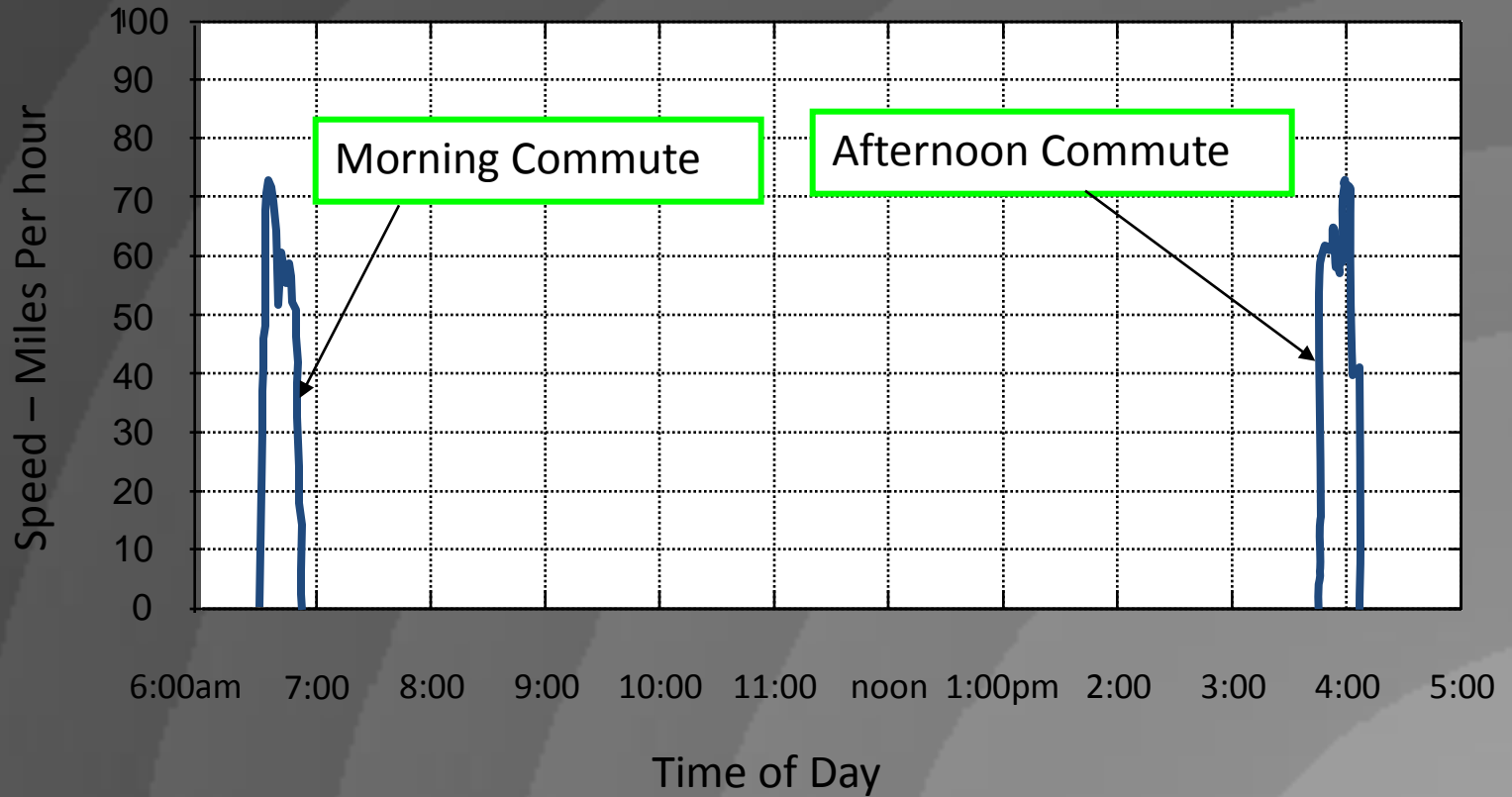

Driver #231's Morning Commute

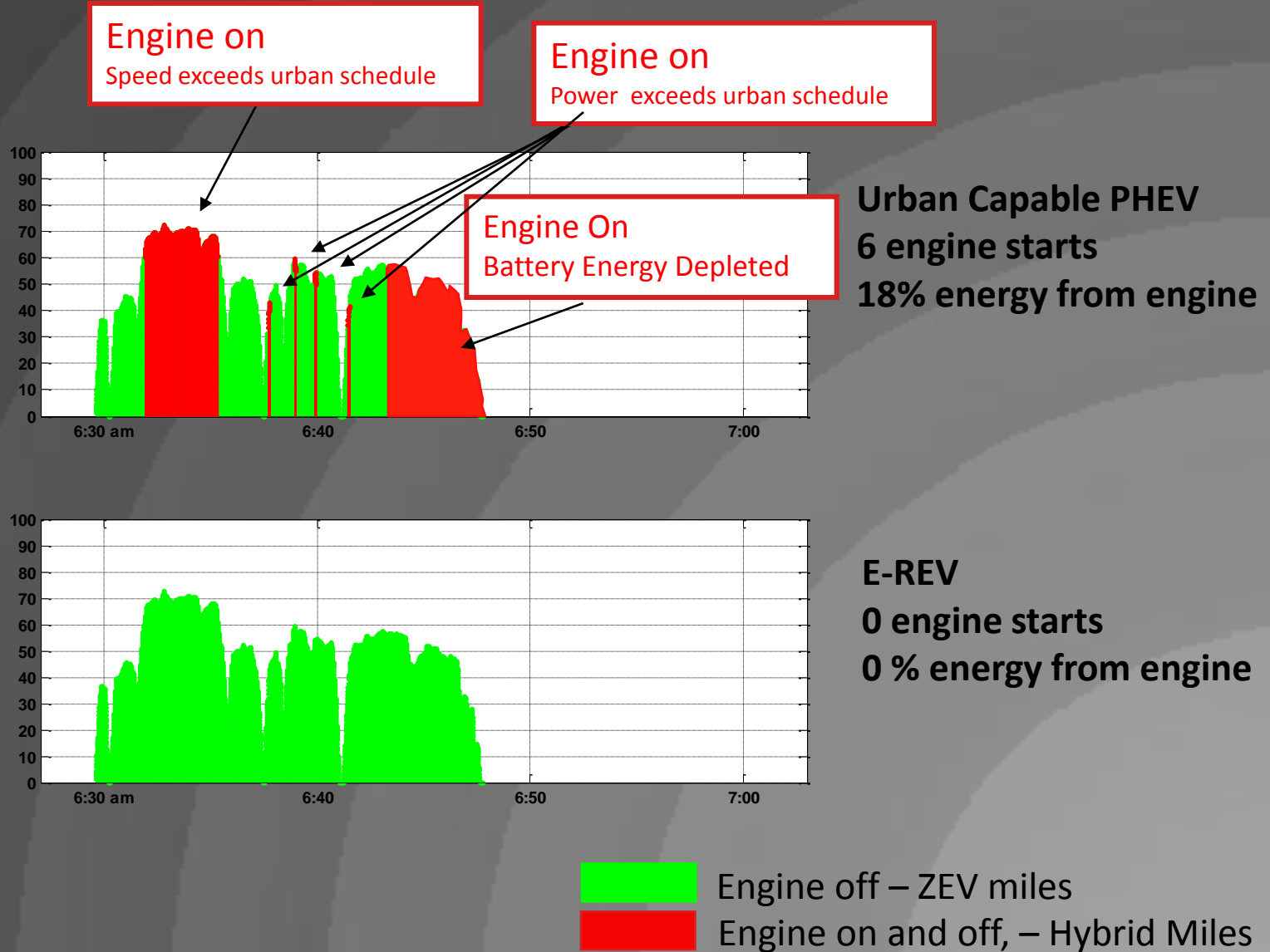

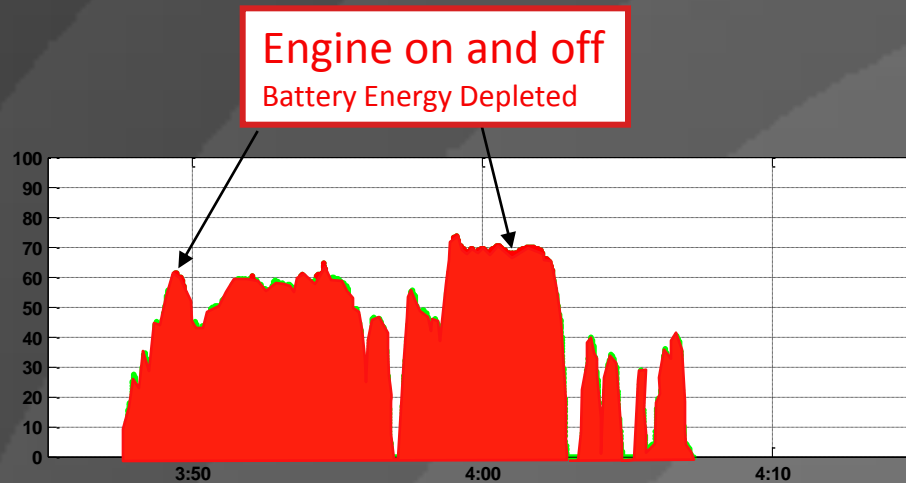

Driver #231's Afternoon Commute

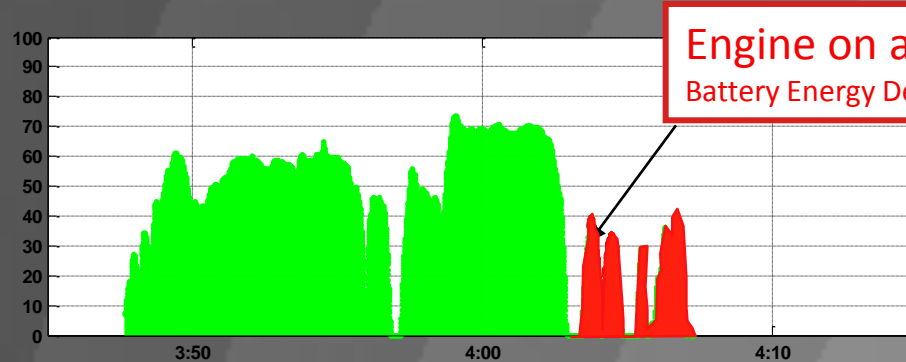

Urban Capable PHEV
1 initial engine start
100% energy from engine



E-REV
1 engine start
5% energy from engine

 Engine off – ZEV miles
 Engine on and off, – Hybrid Miles

Differences in PHEV and E-REV Energy Usage

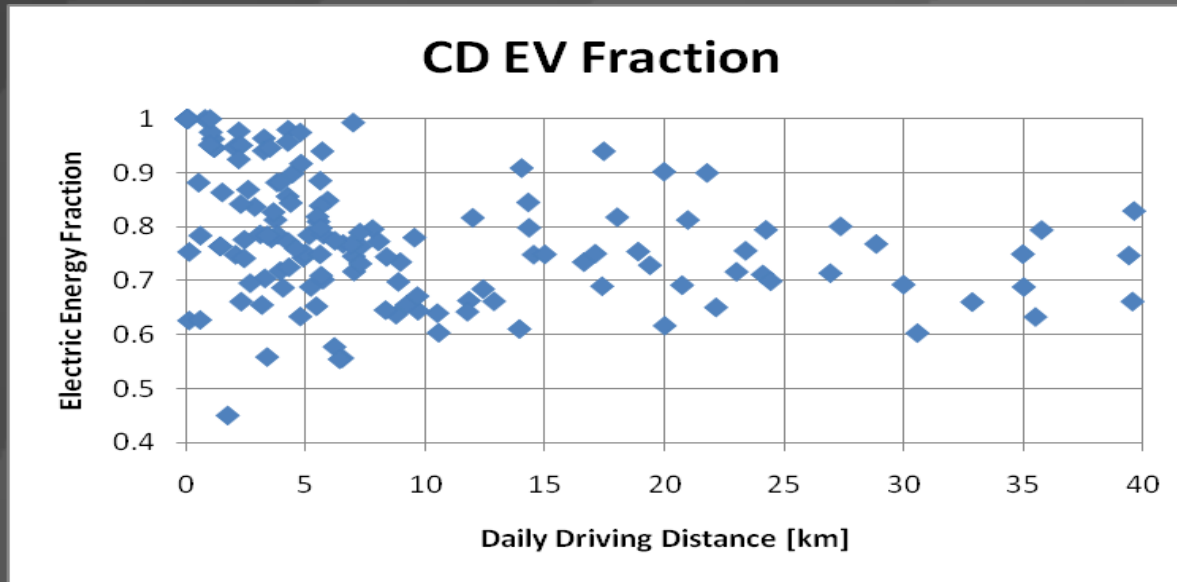

- SCAG survey reveals that 30% of all aggregate driving energy is used at power levels and speed levels beyond the “Urban” power and speed levels (greater than 56 mph or greater than 53 kW)
- PHEV uses a 70% EV energy fraction and a 30% gasoline fraction in Charge Depleting (CD) Mode (*energy remaining in the battery*)
- E-REV uses a 100% energy fraction in CD Mode

Fuel & Battery Use vs Distance Driven

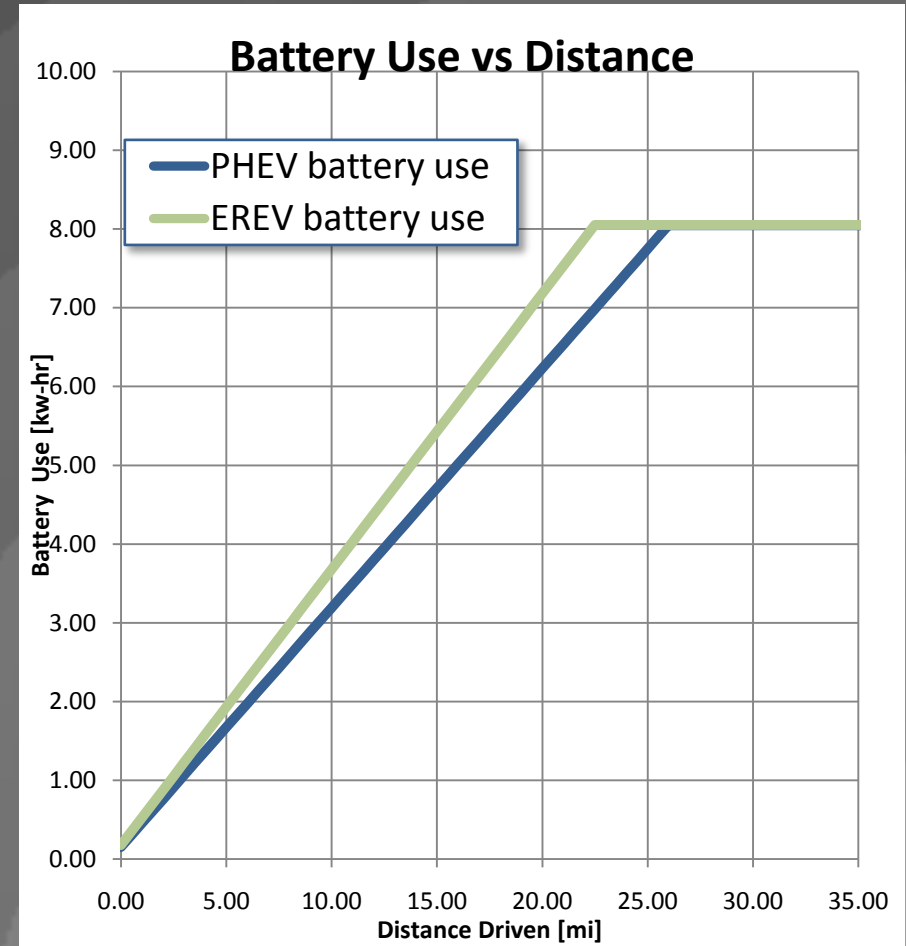
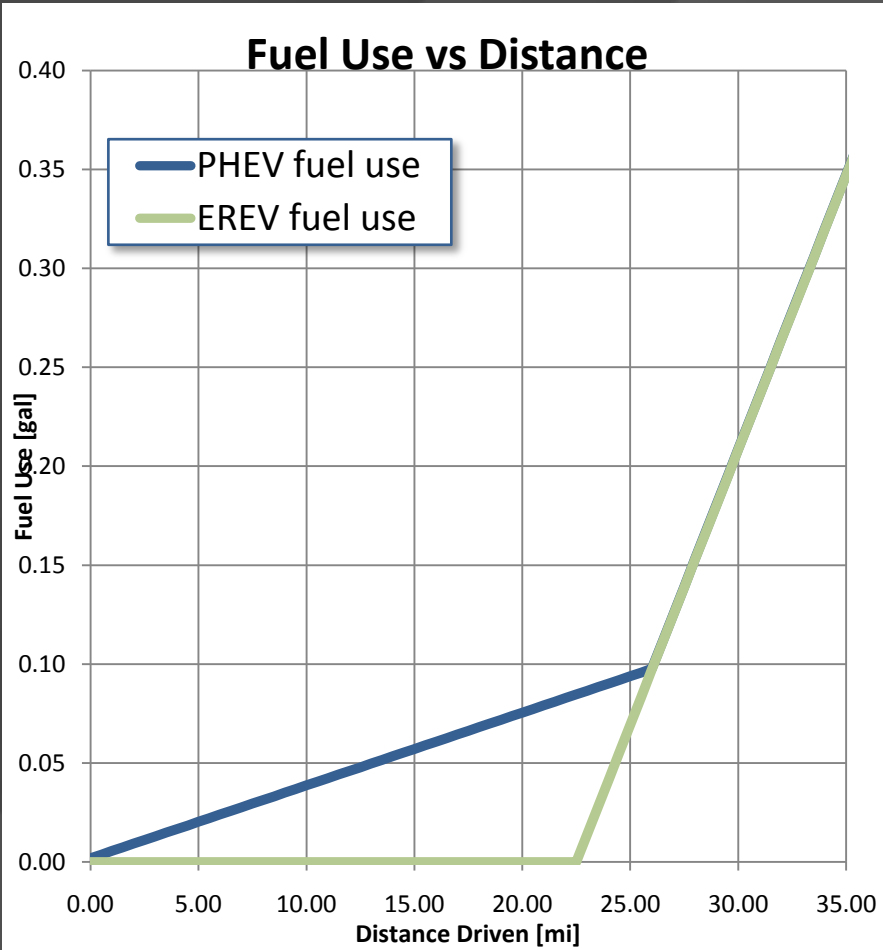

- EREV and PHEV use same fuel for all travel beyond charge-depleting operation.

Where are the Cars?

Fleet Distribution during week

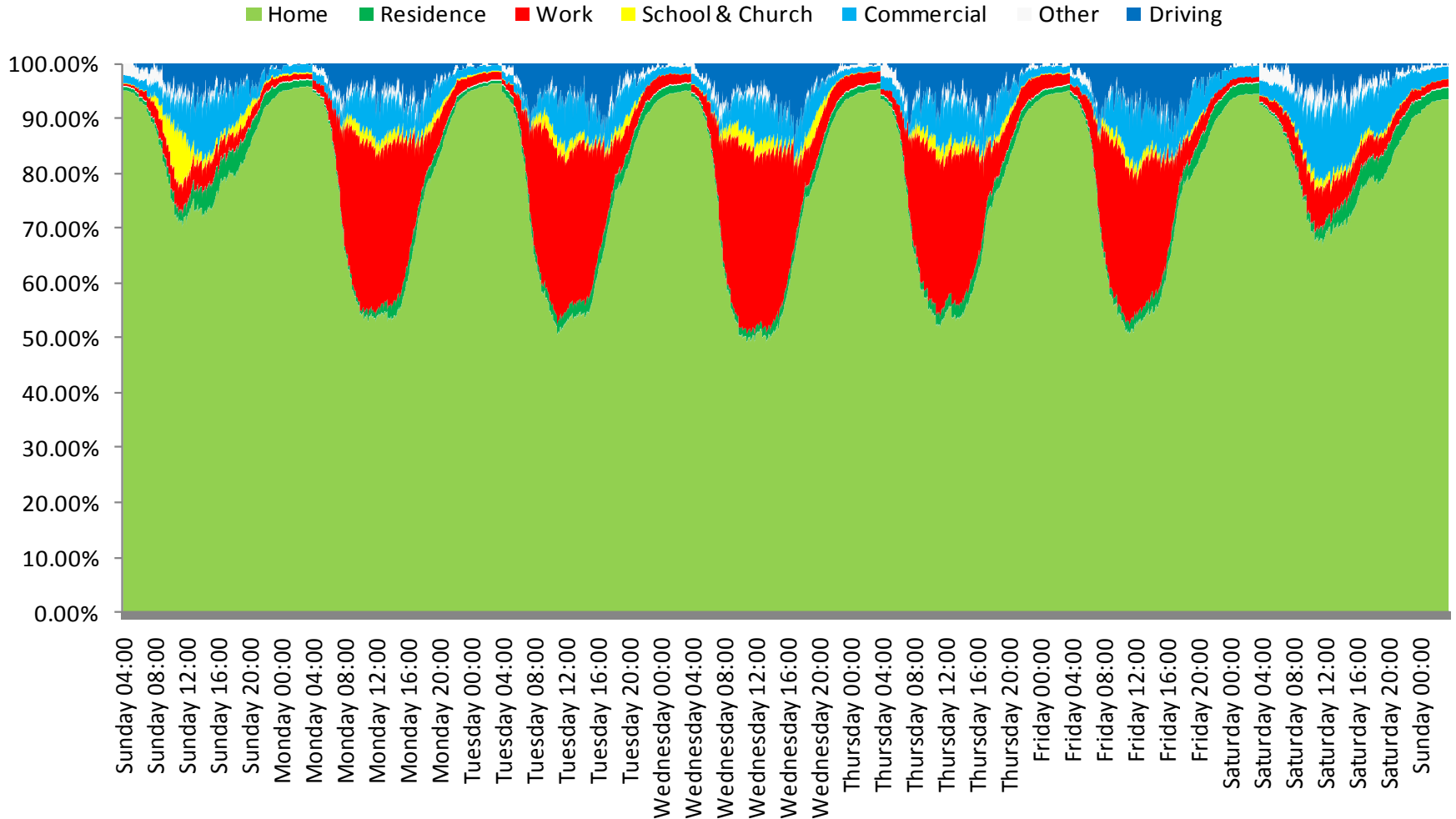

How far do people drive?

2001 USA Daily Distance vs Fraction of Driven Vehicles

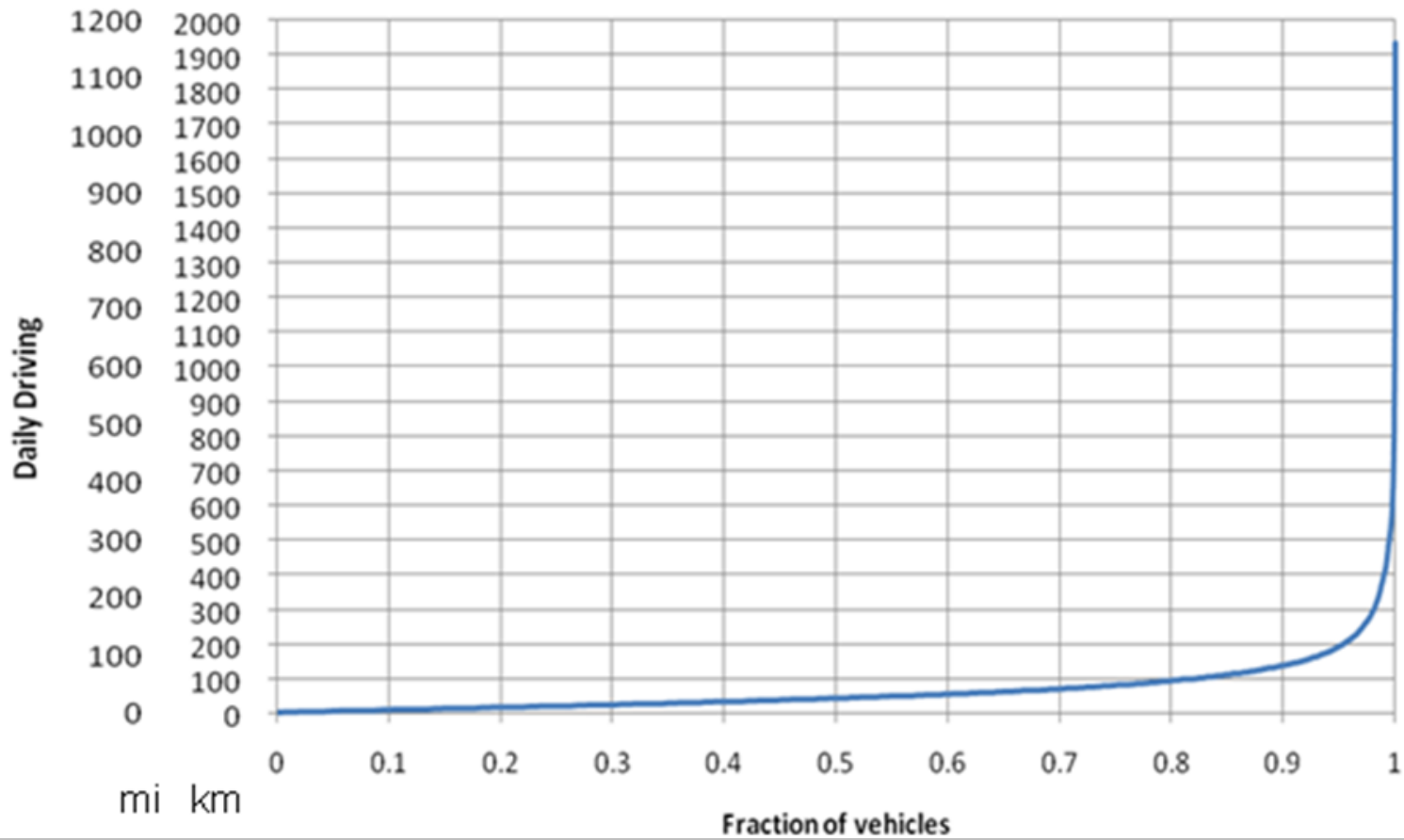

Petroleum Displacement and CO₂ Reduction - 3.3 kw Charging at Work & Home

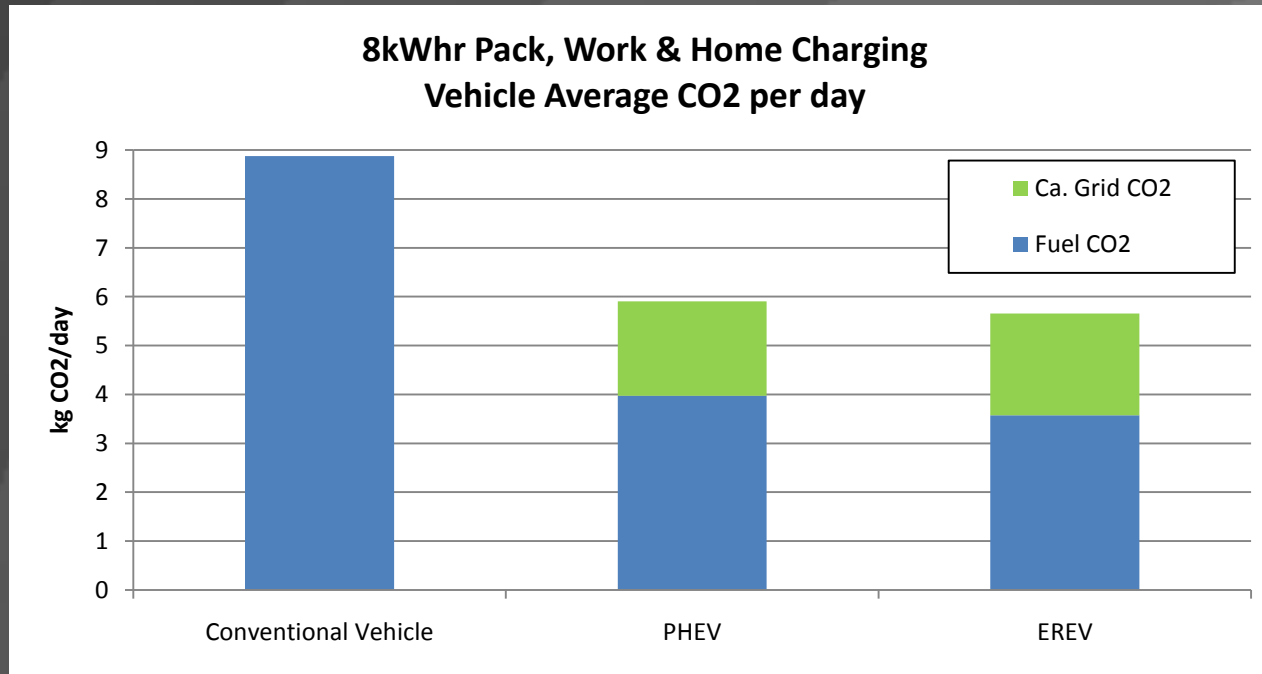

- For the same size battery pack
 - The EREV displaces 60% of fuel versus 55% for the PHEV.
 - The EREV displaces 36% of CO₂ versus 33% for the PHEV.

Three Charging Scenarios Examined

- 1.1 kW charging: 15 Amp, 110 volt outlet
 - Restricted to at home only
 - 9 pm to 9 am; randomized start; charge until full
 - effectively one charge per day
- 3.3 kW charging: 15 amp, 220 volt outlet
 - Restricted to home and work
 - Charge at any time; charge until full
 - effectively two charges per day
- 6.6 kW charging: 30 amp, 220 volt outlet
 - Unrestricted location; wherever you park
 - Charge at anytime; charge until full
 - effectively unlimited charges per day



E-REV Fuel Displacement Advantage Grows with Increasing Battery Size, More Charging

Fuel Use/Day vs Battery Size

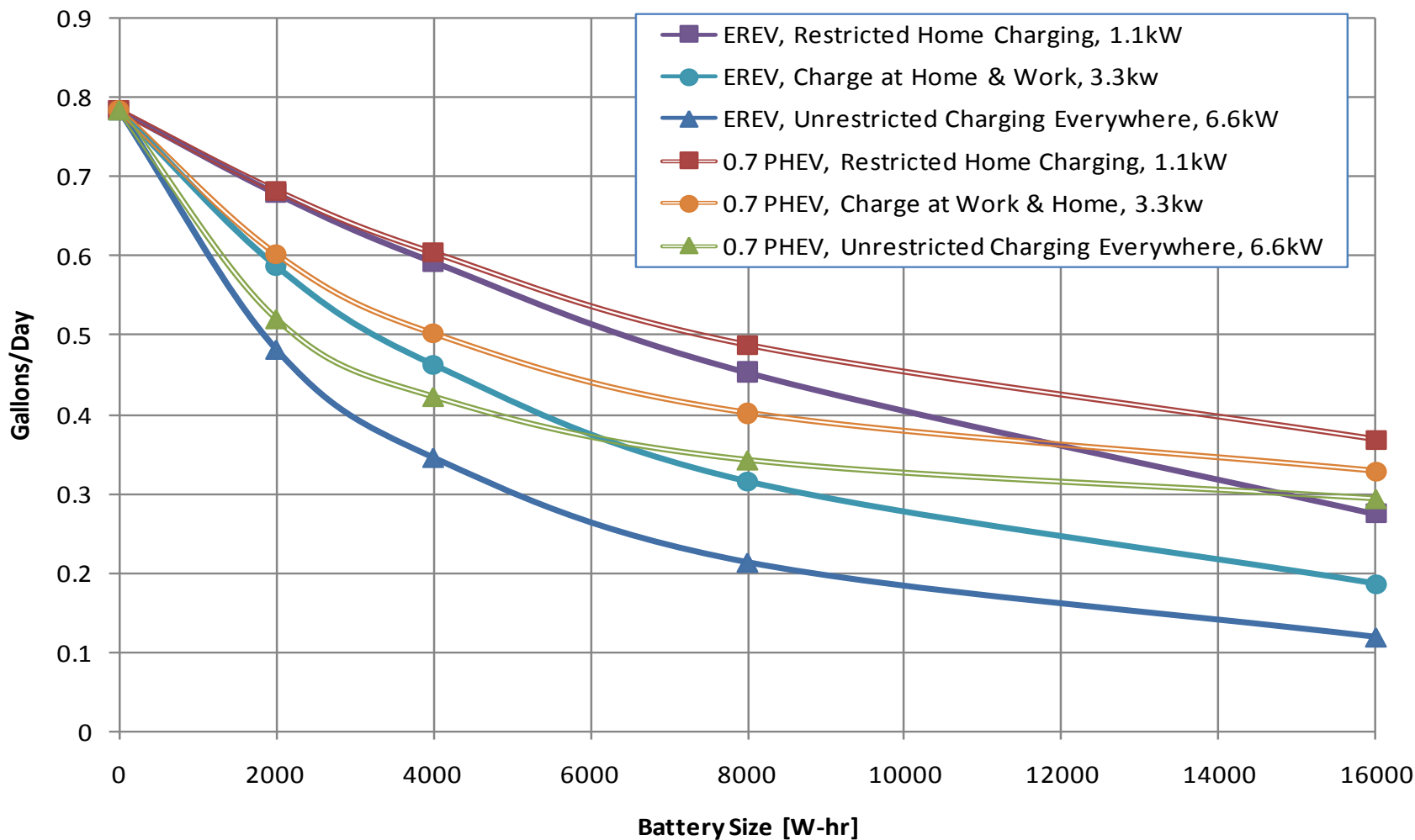

Powertrain and Infrastructure can replace batteries

an example

Fuel Use/Day vs Battery Size

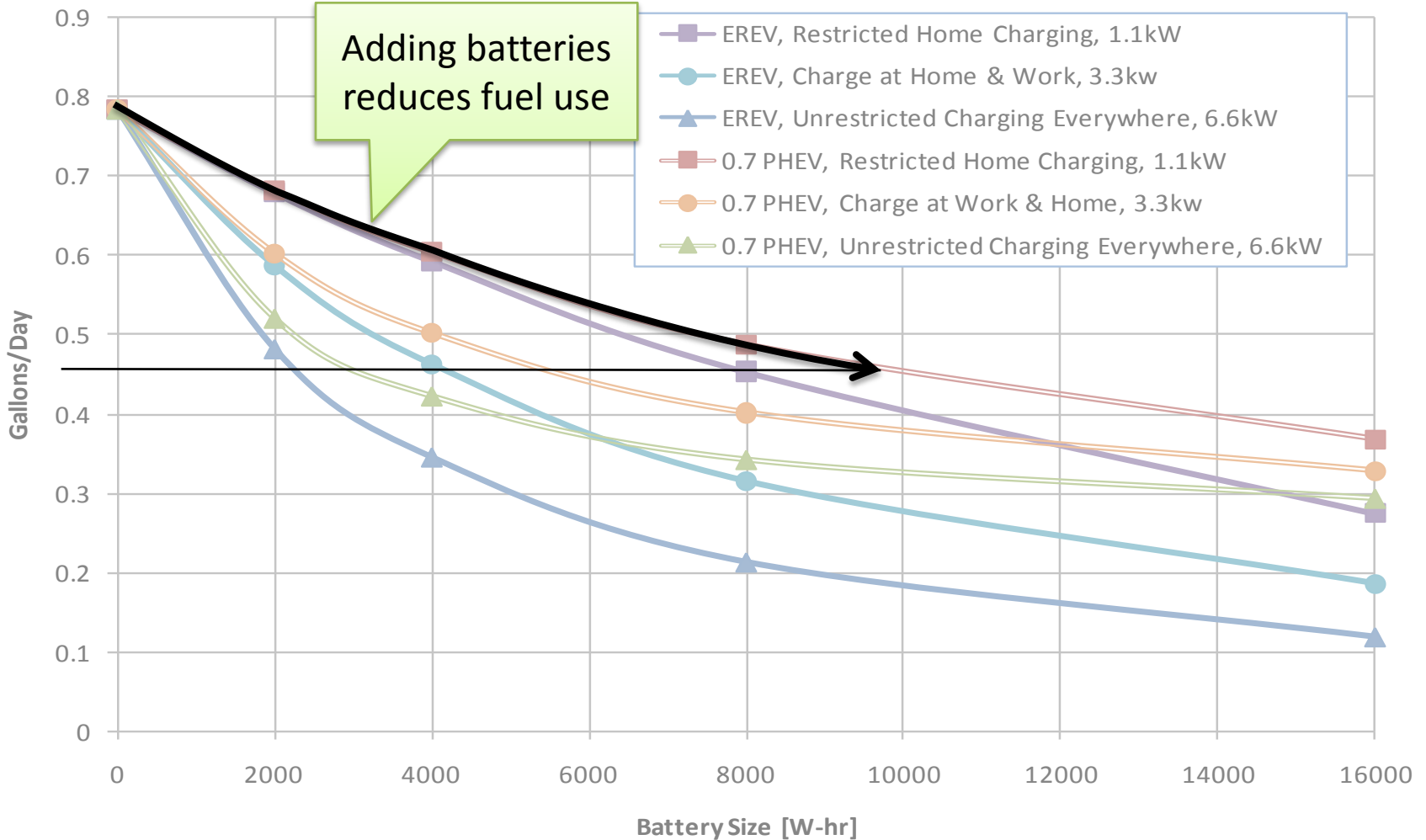

Powertrain and Infrastructure can replace batteries

an example

Fuel Use/Day vs Battery Size

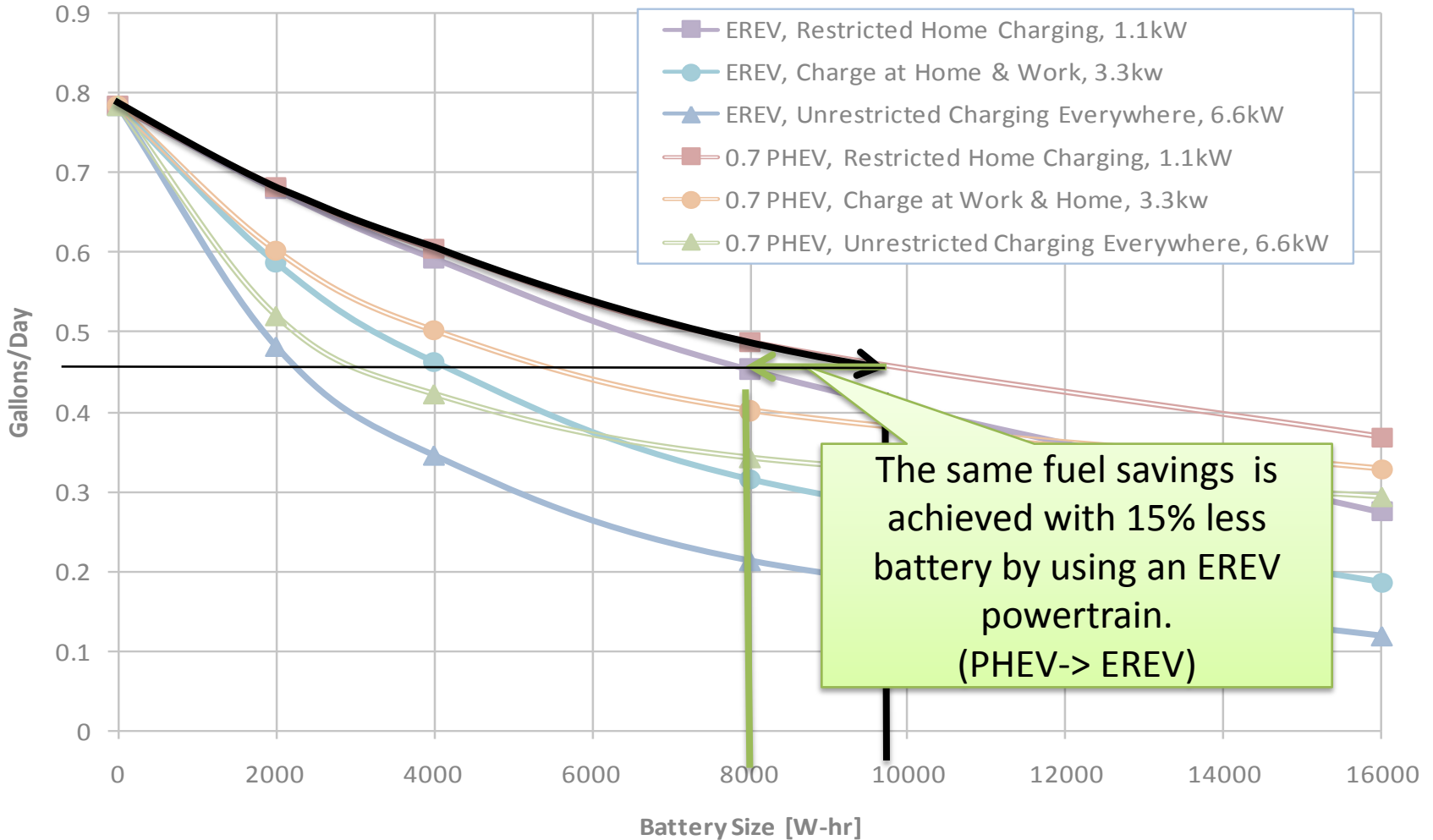

Powertrain and Infrastructure can replace batteries

an example

Fuel Use/Day vs Battery Size

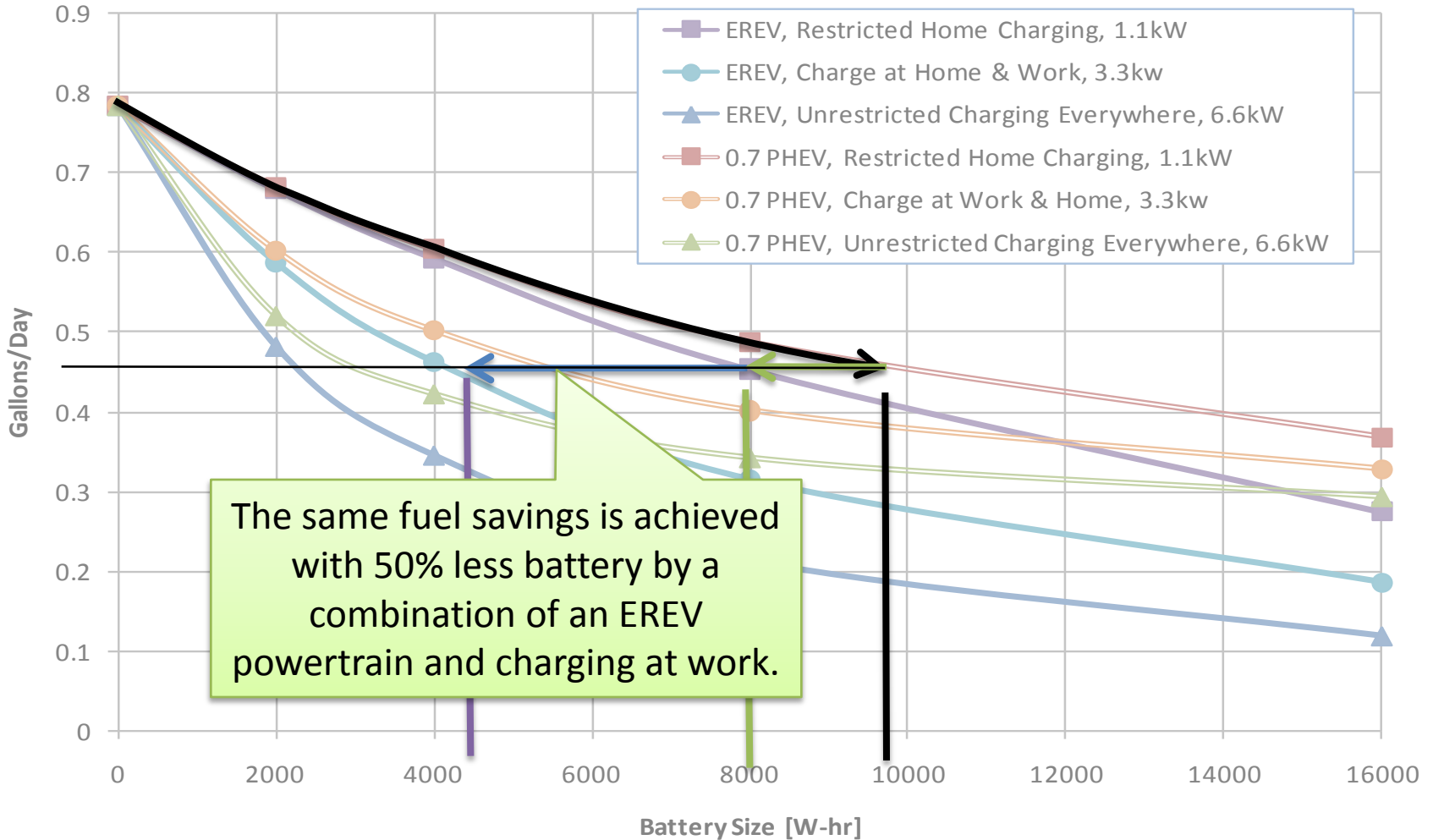

Powertrain and Infrastructure can replace batteries an example

Fuel Use/Day vs Battery Size

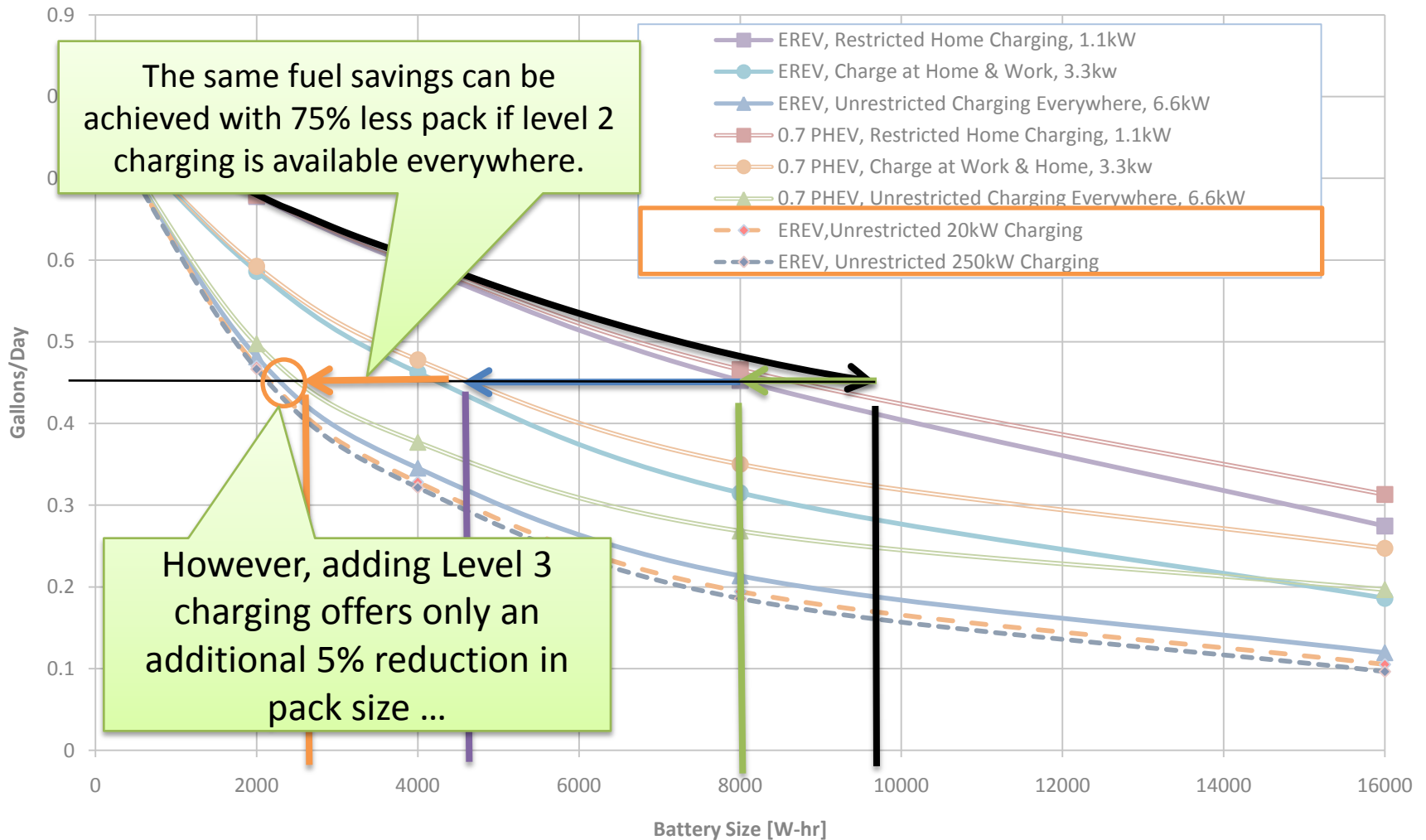

Powertrain and Infrastructure increase fuel savings an example

Fuel Use/Day vs Battery Size

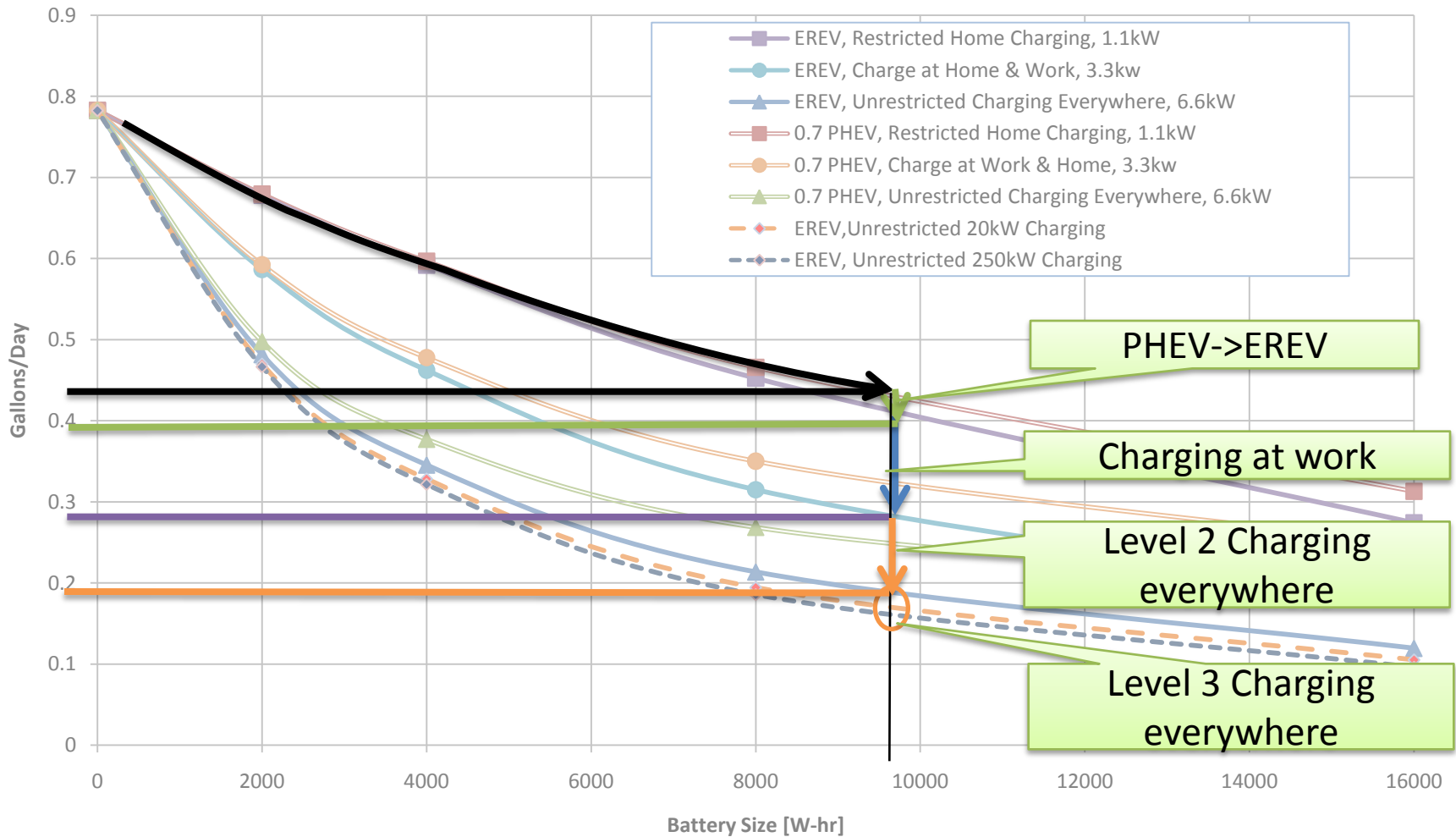

Infrastructure Capacity Does not Appear to be a Constraint to Vehicle Electrification

Expected Charger Wall Power
8kW-hr EREV, 3.3kW Charger, Charge at Work & Home

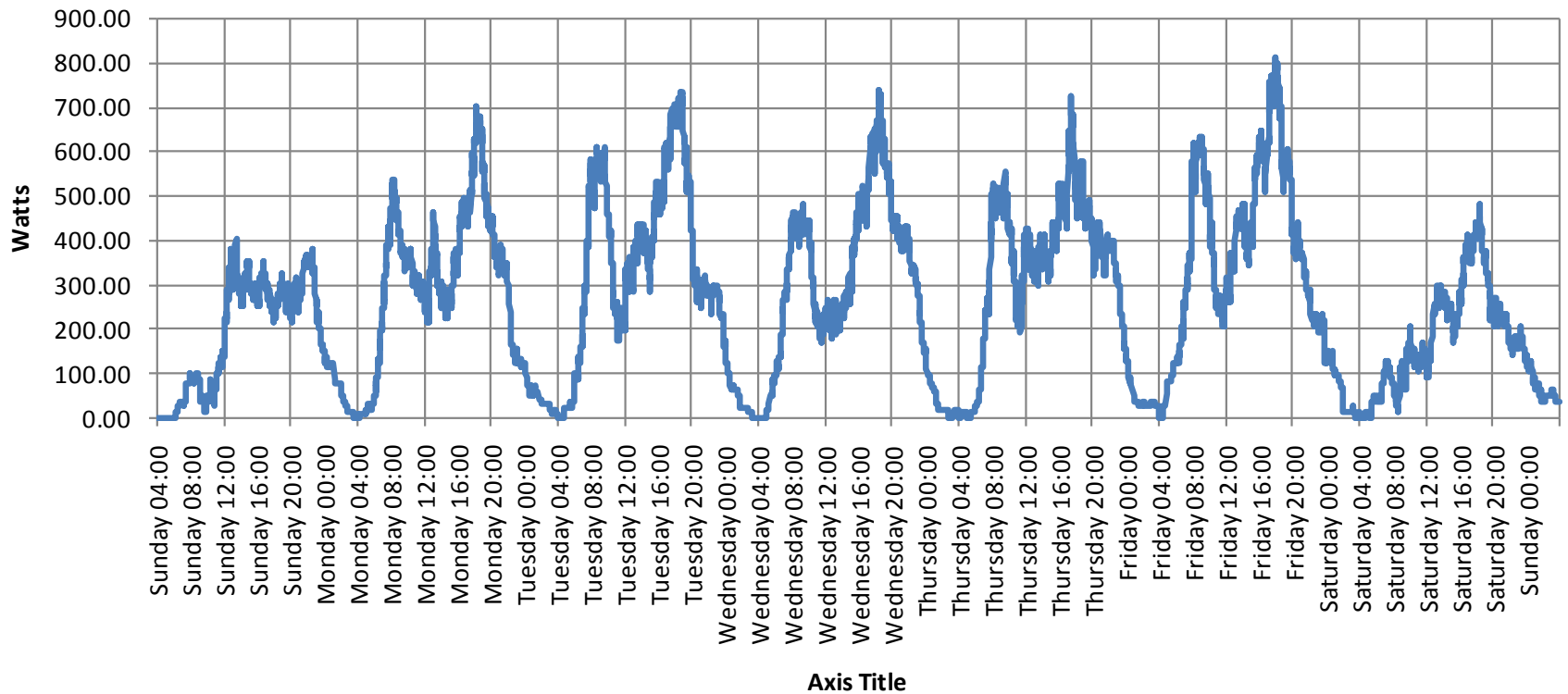

Even at higher Peak Charge rates, Grid Capacity Does not Appear to be a Large Issue

Expected Peak Electrical Power

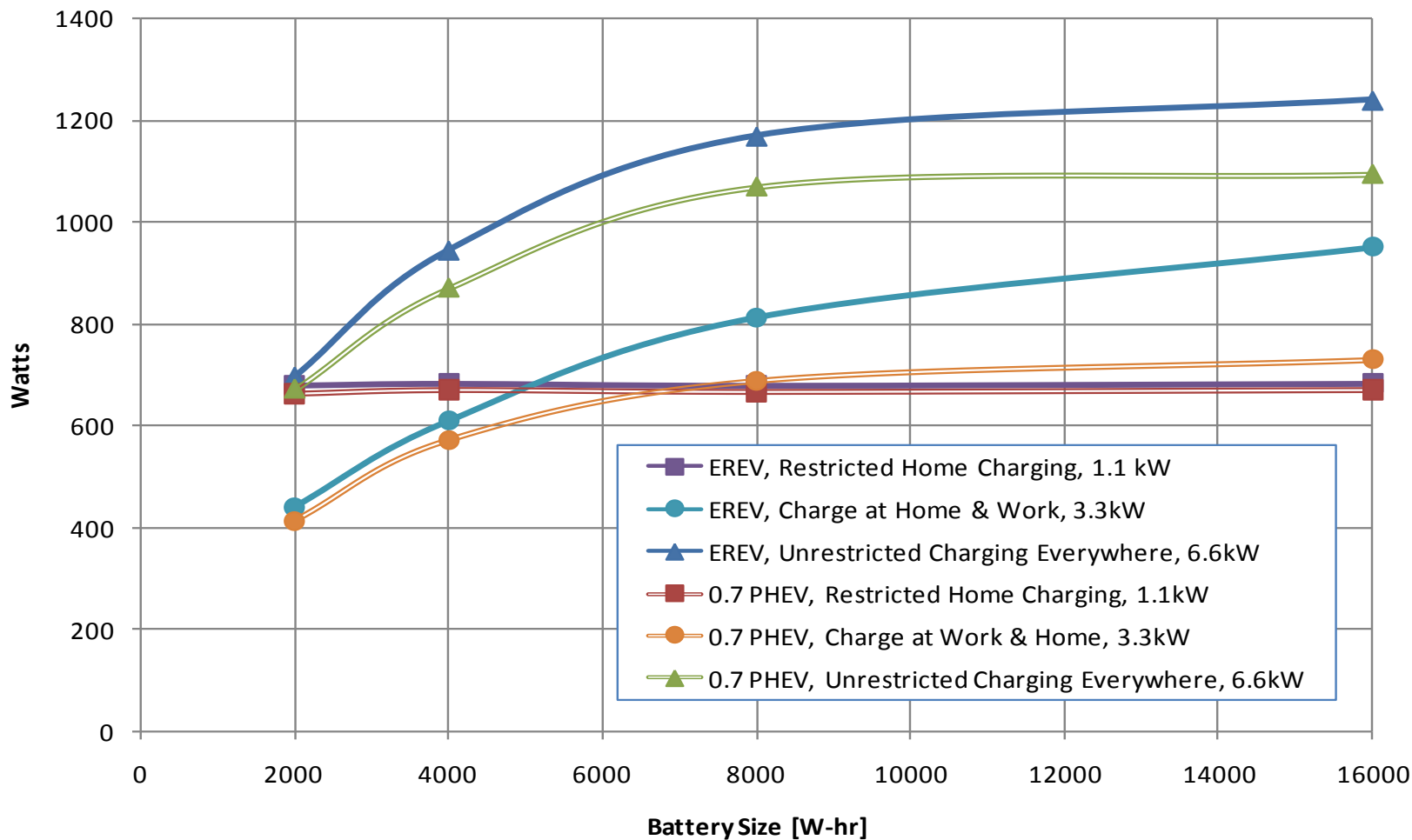

Conclusions

- 1. E-REVs offer an advantage over PHEVs for fuel displaced and CO2 reduced. This advantage is more pronounced with larger batteries. E.g, an 8 kWhr E-REV will give an 11% reduction in fuel consumed relative to an 8kWhr PHEV. (3.3 kW charging at home and work)**
- 2. Since E-REVs are more likely to be produced with larger batteries than PHEVs, an 8kWhr E-REV shows an 23% reduction in fuel consumed and CO2 generated compared to a 2kWhr PHEV. (3.3 kW charging at home and at work)**
- 3. If renewable electricity is used CO2 reduction is equal to fuel displacement.**
- 4. The grid capacity impact of introducing PHEVs and E-REVs is not, in general, great. Considering an 8kWhr E-REV using a 3.3kW charge has an expected peak grid load roughly of roughly 800 Watts. This is equivalent to two plasma TVs.**
- 5. Making charging available at work significantly improves the ability of an E-REV or PHEV to displace fuel. For instance, a 8 kWhr E-REV charged at 3.3 kW at home and at work will lower fuel consumption by 24% when compared to 1.1kW charging restricted to use only at home.**
- 6. An infrastructure improvement allowing multiple charges per day is one factor that could allow a reduction in E-REV or PHEV battery size while maintaining similar levels of petroleum displacement and CO2 reduction.**



Thank You!

