

EPA 402-R-10-001a  
www.epa.gov/narel  
October 2011  
Revision 0.1

# **Rapid Radiochemical Method for Americium-241 in Water for Environmental Remediation Following Homeland Security Events**

**U.S. Environmental Protection Agency**

**Office of Air and Radiation  
Office of Radiation and Indoor Air  
National Air and Radiation Environmental Laboratory  
Montgomery, AL 36115**

**Office of Research and Development  
National Homeland Security Research Center  
Cincinnati, OH 45268**

### Revision History

Revision 0	Original release.	02/23/2010
Revision 0.1	<ul style="list-style-type: none"> <li>• Corrected typographical and punctuation errors.</li> <li>• Improved wording consistency with other methods.</li> <li>• Corrected specification of analytical balance (6.1) to 10<sup>-4</sup>-g readability.</li> <li>• Added pH paper to list of equipment and supplies (6.6).</li> <li>• Added equations in 12.1.2 that allow theoretical calculation of the MDC and critical level for different decision error rates.</li> <li>• Updated footnote 2 to further clarify origin of critical value and minimum detectable concentration formulations.</li> <li>• Updated rounding example in 12.2.2.2 for clarity.</li> <li>• (Deleted Appendix (Composition of Atlanta tap waster) as irrelevant.</li> </ul>	10/28/2011

This report was prepared for the National Air and Radiation Environmental Laboratory of the Office of Radiation and Indoor Air and the National Homeland Security Research Center of the Office of Research and Development, United States Environmental Protection Agency. It was prepared by Environmental Management Support, Inc., of Silver Spring, Maryland, under contracts 68-W-03-038, work assignment 43, and EP-W-07-037, work assignments B-41 and I-41, all managed by David Garman. Mention of trade names or specific applications does not imply endorsement or acceptance by EPA.

**AMERICIUM-241 IN WATER:  
RAPID METHOD FOR HIGH-ACTIVITY SAMPLES**

1. Scope and Application

- 1.1. The method will be applicable to samples where radioactive contamination is either from known or unknown origins. If any filtration of the sample is performed prior to starting the analysis, those solids should be analyzed separately. The results from the analysis of these solids should be reported separately (as a suspended activity concentration for the water volume filtered), but identified with the filtrate results.
- 1.2. The method is specific for  $^{241}\text{Am}$  in drinking water and other aqueous samples. However, if any isotopes of curium are present in the sample, they will be carried with americium during the analytical separation process and will be observed in the final alpha spectrum.
- 1.3. The method uses rapid radiochemical separation techniques for determining americium in water samples following a radiological or nuclear incident. Although the method can detect concentrations of  $^{241}\text{Am}$  on the same order of magnitude as methods used for the Safe Drinking Water Act (SDWA), the method is not a substitute for SDWA-approved methods for  $^{241}\text{Am}$ .
- 1.4. The method is capable of achieving a required method uncertainty for  $^{241}\text{Am}$  of 1.9 pCi/L at an analytical action level of 15 pCi/L. To attain the stated measurement quality objectives (MQOs) (see Sections 9.3 and 9.4), a sample volume of approximately 200 mL and count time of at least 1 hour are recommended. The sample turnaround time and throughput may vary based on additional project MQOs, the time for analysis of the final counting form, and initial sample volume. The method must be validated prior to use following the protocols provided in *Method Validation Guide for Qualifying Methods Used by Radiological Laboratories Participating in Incident Response Activities* (EPA 2009, reference 16.5).
- 1.5. The method is intended to be used for water samples that are similar in composition to drinking water. The rapid  $^{241}\text{Am}$  method was evaluated following the guidance presented for “Level E Method Validation: Adapted or Newly Developed Methods, Including Rapid Methods” in *Method Validation Guide for Qualifying Methods Used by Radiological Laboratories Participating in Incident Response Activities* (EPA 2009, reference 16.5) and Chapter 6 of *Multi-Agency Radiological Laboratory Analytical Protocols Manual* (MARLAP 2004, reference 16.6). Multi-radionuclide analysis using sequential separation may be possible using this method in conjunction with other rapid methods.
- 1.6. The method is applicable to the determination of soluble  $^{241}\text{Am}$ . The method is not applicable to the determination of  $^{241}\text{Am}$  in highly insoluble particulate matter possibly present in water samples contaminated as a result of a radiological dispersion device (RDD) event.

2. Summary of Method

- 2.1. The method is based on a sequence of two chromatographic extraction resins used to concentrate, isolate, and purify americium by removing interfering radionuclides as well as other components of the water matrix in order to prepare the americium fraction for counting by alpha spectrometry. The method utilizes vacuum-assisted flow to

improve the speed of the separations. Prior to the use of the extraction resins, the water sample is filtered as necessary to remove any insoluble fractions, equilibrated with  $^{243}\text{Am}$  tracer, and concentrated by evaporation or calcium phosphate precipitation. The sample test source (STS) is prepared by microprecipitation with  $\text{NdF}_3$ . Standard laboratory protocol for the use of an alpha spectrometer should be used when the sample is ready for counting.

### 3. Definitions, Abbreviations, and Acronyms

- 3.1. Analytical Protocol Specifications (APS). The output of a directed planning process that contains the project's analytical data needs and requirements in an organized, concise form.
- 3.2. Analytical Action Level (AAL). The term "analytical action level" is used to denote the value of a quantity that will cause the decisionmaker to choose one of the alternative actions.
- 3.3. Analytical Decision Level (ADL). The analytical decision level refers to the value that is less than the AAL and based on the acceptable error rate and the required method uncertainty.
- 3.4. Discrete Radioactive Particles (DRPs or Hot Particles). Particulate matter in a sample of any matrix where a high concentration of radioactive material is contained in a tiny particle ( $\mu\text{m}$  range).
- 3.5. *Multi-Agency Radiological Laboratory Analytical Protocols Manual* (See Reference 16.6.).
- 3.6. Measurement Quality Objective (MQO). MQOs are the analytical data requirements of the data quality objectives and are project- or program-specific. They can be quantitative or qualitative. MQOs serve as measurement performance criteria or objectives of the analytical process.
- 3.7. Radiological Dispersal Device (RDD), i.e., a "dirty bomb." This is an unconventional weapon constructed to distribute radioactive material(s) into the environment either by incorporating them into a conventional bomb or by using sprays, canisters, or manual dispersal.
- 3.8. Required Method Uncertainty ( $u_{\text{MR}}$ ). The required method uncertainty is a target value for the individual measurement uncertainties, and is an estimate of uncertainty (of measurement) before the sample is actually measured. The required method uncertainty is applicable below an AAL.
- 3.9. Required Relative Method Uncertainty ( $\phi_{\text{MR}}$ ). The required relative method uncertainty is the  $u_{\text{MR}}$  divided by the AAL and typically expressed as a percentage. It is applicable above the AAL.
- 3.10. Sample Test Source (STS). This is the final form of the sample that is used for nuclear counting. This form is usually specific for the nuclear counting technique used in the method, such as a solid deposited on a filter for alpha spectrometry analysis.

### 4. Interferences

- 4.1. Radiological: Alpha-emitting radionuclides with irresolvable alpha energies, such as  $^{241}\text{Am}$  (5.48 MeV),  $^{238}\text{Pu}$  (5.50 MeV), and  $^{228}\text{Th}$  (5.42 MeV), must be chemically separated to enable radionuclide-specific measurements. This method separates these radionuclides effectively. The significance of peak overlap will be determined by the

individual detector's alpha energy resolution characteristics and the quality of the final precipitate that is counted.

- 4.2. Non-Radiological: Very high levels of competing higher valence anions (greater than divalent such as phosphates) will lead to lower yields when using the evaporation option due to competition with active sites on the resin. If higher valence anions are present, the phosphate precipitation option may need to be used initially in place of evaporation. If calcium phosphate coprecipitation is performed to collect americium (and other potentially present actinides) from large-volume samples, the amount of phosphate added to coprecipitate the actinides (in Step 11.1.4.3) should be reduced to accommodate the sample's high phosphate concentration.

## 5. Safety

### 5.1. General

- 5.1.1. Refer to your safety manual for concerns of contamination control, personal exposure monitoring and radiation dose monitoring.
- 5.1.2. Refer to the laboratory chemical hygiene plan (or equivalent) for general safety rules regarding chemicals in the workplace.

### 5.2. Radiological

#### 5.2.1. Hot Particles (DRPs)

- 5.2.1.1. Hot particles, also termed "discrete radioactive particles" (DRPs), will be small, on the order of 1 mm or less. Typically, DRPs are not evenly distributed in the media and their radiation emissions are not uniform in all directions (anisotropic). Filtration using a 0.45- $\mu\text{m}$  or finer filter will minimize the presence of these particles.
  - 5.2.1.2. Care should be taken to provide suitable containment for filter media used in the pretreatment of samples that may have DRPs, because the particles become highly statically charged as they dry out and will "jump" to other surfaces causing contamination.
  - 5.2.1.3. Filter media should be individually surveyed for the presence of these particles, and this information should be reported with the final sample results.
- 5.2.2. For samples with detectable activity concentrations of this radionuclide, labware should be used only once due to potential for cross contamination.

### 5.3. Procedure-Specific Non-Radiological Hazards

Particular attention should be paid to the use of hydrofluoric acid (HF). HF is an extremely dangerous chemical used in the preparation of some of the reagents and in the microprecipitation procedure. Appropriate personal protective equipment (PPE) must be used in strict accordance with the laboratory safety program specification.

## 6. Equipment and Supplies

- 6.1. Analytical balance with a  $10^{-4}$ -g readability or better.
- 6.2. Cartridge reservoirs, 10- or 20-mL syringe style with locking device, or equivalent.
- 6.3. Centrifuge able to accommodate 250-mL flasks.
- 6.4. Centrifuge flasks, 250-mL capacity.
- 6.5. Filter with 0.45- $\mu\text{m}$  membrane.

- 6.6. pH paper.
- 6.7. Filter apparatus with 25-mm-diameter polysulfone filtration chimney, stem support, and stainless steel support. A single-use (disposable) filter funnel/filter combination may be used, to avoid cross-contamination.
- 6.8. 25-mm polypropylene filter, 0.1- $\mu$ m pore size, or equivalent.
- 6.9. Stainless steel planchets or other sample mounts able to hold the 25 mm filter.
- 6.10. Tweezers.
- 6.11. 100- $\mu$ L pipette or equivalent and appropriate plastic tips.
- 6.12. 10-mL plastic culture tubes with caps.
- 6.13. Tips, white inner, Eichrom part number AC-1000-IT, or equivalent.
- 6.14. Tips, yellow outer, Eichrom part number AC-1000-OT, or equivalent.
- 6.15. Vacuum box, such as Eichrom part number AC-24-BOX, or equivalent.
- 6.16. Vortex mixer.
- 6.17. Vacuum pump or laboratory vacuum system.
- 6.18. Miscellaneous laboratory ware, plastic or glass, 250 mL and 350 mL.

## 7. Reagents and Standards

**Note: All reagents are American Chemical Society (ACS) reagent grade or equivalent unless otherwise specified.**

**Note: Unless otherwise indicated, all references to laboratory water should be understood to mean Type I Reagent water. All solutions used in microprecipitation should be prepared with water filtered through a 0.45- $\mu$ m (or better) filter.**

- 7.1. Am-243 tracer solution: 6–10 dpm of  $^{243}\text{Am}$  per aliquant, activity added known to at least 5% (combined standard uncertainty  $\leq 5\%$ ).
- 7.2. Ammonium hydrogen phosphate (3.2 M): Dissolve 106 g of ammonium hydrogen phosphate ( $(\text{NH}_4)_2\text{HPO}_4$ ) in 200 mL of water, heat gently to dissolve, and dilute to 250 mL with water.
- 7.3. Ammonium hydroxide (15 M): Concentrated  $\text{NH}_4\text{OH}$ , available commercially.
- 7.4. Ammonium thiocyanate indicator (1 M): Dissolve 7.6 g of ammonium thiocyanate ( $\text{NH}_4\text{SCN}$ ) in 90 mL of water and dilute to 100 mL with water. An appropriate quantity of sodium thiocyanate (8.1 g) or potassium thiocyanate (9.7 g) may be substituted for ammonium thiocyanate.
- 7.5. Ascorbic acid (1 M): Dissolve 17.6 g of ascorbic acid ( $\text{C}_6\text{H}_8\text{O}_6$ ) in 90 mL of water and dilute to 100 mL with water. Prepare weekly.
- 7.6. Calcium nitrate (0.9 M): Dissolve 53 g of calcium nitrate tetrahydrate ( $\text{Ca}(\text{NO}_3)_2 \cdot 4\text{H}_2\text{O}$ ) in 100 mL of water and dilute to 250 mL with water.
- 7.7. Ethanol, 100%: Anhydrous  $\text{C}_2\text{H}_5\text{OH}$ , available commercially.
  - 7.7.1. Ethanol (~80% v/v): Mix 80 mL 100% ethanol and 20 mL water.
- 7.8. Ferrous sulfamate (0.6 M): Add 57 g of sulfamic acid ( $\text{NH}_2\text{SO}_3\text{H}$ ) to 150 mL of water, heat to 70°C. Slowly add 7 g of iron powder (< 100 mesh size) while heating and stirring with a magnetic stirrer until dissolved (may take as long as two hours). Filter the hot solution using a qualitative filter, transfer to flask, and dilute to 200 mL with water. Prepare fresh weekly.
- 7.9. Hydrochloric acid (12 M): Concentrated HCl, available commercially.

- 7.9.1. Hydrochloric acid (9 M): Add 750 mL of concentrated HCl to 100 mL of water and dilute to 1 L with water.
  - 7.9.2. Hydrochloric acid (4 M): Add 333 mL of concentrated HCl to 500 mL of water and dilute to 1 L with water.
  - 7.9.3. Hydrochloric acid (1 M): Add 83 mL of concentrated HCl to 500 mL of water and dilute to 1 L with water.
  - 7.10. Hydrofluoric acid (28 M): Concentrated HF, available commercially.
    - 7.10.1. Hydrofluoric acid (0.58 M): Add 20 mL of concentrated HF to 980 mL of filtered demineralized water and mix. Store in a plastic bottle.
  - 7.11. Neodymium standard solution (1000  $\mu\text{g/mL}$ ): May be purchased from a supplier of standards for atomic spectroscopy.
  - 7.12. Neodymium carrier solution (0.50 mg/mL): Dilute 10 mL of the neodymium standard solution (7.11) to 20.0 mL with filtered demineralized water. This solution is stable.
  - 7.13. Neodymium fluoride substrate solution (10  $\mu\text{g/mL}$ ): Pipette 5 mL of neodymium standard solution (7.11) into a 500-mL plastic bottle. Add 460 mL of 1-M HCl to the plastic bottle. Cap the bottle and shake to mix. Measure 40 mL of concentrated HF in a plastic graduated cylinder and add to the bottle. Recap the bottle and shake to mix thoroughly. This solution is stable for up to six months.
  - 7.14. Nitric acid (16 M): Concentrated  $\text{HNO}_3$ , available commercially.
    - 7.14.1. Nitric acid (3 M): Add 191 mL of concentrated  $\text{HNO}_3$  to 700 mL of water and dilute to 1 L with water.
    - 7.14.2. Nitric acid (2 M): Add 127 mL of concentrated  $\text{HNO}_3$  to 800 mL of water and dilute to 1 L with water.
    - 7.14.3. Nitric acid (0.5 M): Add 32 mL of concentrated  $\text{HNO}_3$  to 900 mL of water and dilute to 1 L with water.
  - 7.15. Nitric acid (2M) – sodium nitrite (0.1 M) solution: Add 32 mL of concentrated  $\text{HNO}_3$  (7.14) to 200 mL of water and mix. Dissolve 1.7 g of sodium nitrite ( $\text{NaNO}_2$ ) in the solution and dilute to 250 mL with water. Prepare fresh daily.
  - 7.16. Nitric acid (3 M) – aluminum nitrate (1.0M) solution: Dissolve 213 g of anhydrous aluminum nitrate ( $\text{Al}(\text{NO}_3)_3$ ) in 700 mL of water. Add 190 mL of concentrated  $\text{HNO}_3$  (7.14) and dilute to 1 L with water. An appropriate quantity of aluminum nitrate nonahydrate (375 g) may be substituted for anhydrous aluminum nitrate.
  - 7.17. Phenolphthalein solution: Dissolve 1 g of phenolphthalein in 100 mL 95% isopropyl alcohol and dilute with 100 mL of water.
  - 7.18. TRU Resin: 2-mL cartridge, 50- to 100- $\mu\text{m}$  mesh size, Eichrom part number TR-R50-S and TR-R200-S, or equivalent.
  - 7.19. UTEVA Resin: 2-mL cartridge, 50- to 100- $\mu\text{m}$  mesh size, Eichrom part number UT-R50-S and UT-R200-S, or equivalent.
8. Sample Collection, Preservation, and Storage
    - 8.1. No sample preservation is required if sample is delivered to the laboratory within 3 days of sampling date/time.
    - 8.2. If the dissolved concentration of americium is sought, the insoluble fraction must be removed by filtration before preserving with acid.
    - 8.3. If the sample is to be held for more than 3 days, concentrated  $\text{HNO}_3$  shall be added to achieve a  $\text{pH} < 2$ .

## 9. Quality Control

- 9.1. Batch quality control results shall be evaluated and meet applicable Analytical Project Specifications (APS) prior to release of unqualified data. In the absence of project-defined APS or a project-specific quality assurance project plan (QAPP), the quality control sample acceptance criteria defined in the laboratory quality manual and procedures shall be used to determine acceptable performance for this method.
  - 9.1.1. A laboratory control sample (LCS) shall be run with each batch of samples. The concentration of the LCS shall be at or near the action level or level of interest for the project.
  - 9.1.2. One method blank shall be run with each batch of samples. The laboratory blank should consist of laboratory water.
  - 9.1.3. One laboratory duplicate shall be run with each batch of samples. The laboratory duplicate is prepared by removing an aliquant from the original sample container.
  - 9.1.4. A matrix spike sample may be included as a batch quality control sample if there is concern that matrix interferences may compromise chemical yield measurements or overall data quality.
- 9.2. The source preparation method should produce a sample test source whose spectrum shows the full width at half maximum (FWHM) of ~60-80 keV for each peak in the spectrum. Precipitate reprocessing should be considered if this range of FWHM cannot be achieved.
- 9.3. This method is capable of achieving a  $u_{MR}$  of 1.9 pCi/L at or below an action level of 15 pCi/L. This may be adjusted in the event specific MQOs are different.
- 9.4. This method is capable of achieving a  $\phi_{MR}$  13% above 15 pCi/L. This may be adjusted if the event specific MQOs are different.
- 9.5. This method is capable of achieving a required minimum detectable concentration (MDC) of 1.5 pCi/L.

## 10. Calibration and Standardization

- 10.1. Set up the alpha spectrometry system according to the manufacturer's recommendations. The energy range of the spectrometry system should at least include the region between 3 and 8 MeV.
- 10.2. Calibrate each detector used to count samples according to ASTM Standard Practice D7282, Section 18, "Alpha Spectrometry Instrument Calibrations" (see Reference 16.3).
- 10.3. Continuing Instrument Quality Control Testing shall be performed according to ASTM Standard Practice D7282, Sections 20, 21, and 24.

## 11. Procedure

### 11.1. Water Sample Preparation

- 11.1.1. As required, filter the 100- to 200-mL sample aliquant through a 0.45- $\mu$ m filter and collect the sample in an appropriate size beaker.
- 11.1.2. Acidify the sample with concentrated HNO<sub>3</sub> to a pH of less than 2.0 by adding enough HNO<sub>3</sub>. This usually requires about 2 mL of HNO<sub>3</sub> per 1000 mL of sample.



- 11.1.3. Add 6-10 dpm of  $^{243}\text{Am}$  as a tracer, following laboratory protocol.

**Note: For a sample approximately 100 mL or less, the evaporation option is recommended. Proceed to Step 11.1.5. Otherwise, go to Step 11.1.4.**

- 11.1.4. Calcium phosphate coprecipitation option
- 11.1.4.1. Add 0.5 mL of 0.9-M  $\text{Ca}(\text{NO}_3)_2$  to each beaker. Place each beaker on a hot plate, cover with a watch glass, and heat until boiling.
- 11.1.4.2. Once the sample boils, take the watch glass off the beaker and lower the heat.
- 11.1.4.3. Add 2–3 drops of phenolphthalein indicator and 200  $\mu\text{L}$  of 3.2 M  $(\text{NH}_4)_2\text{HPO}_4$  solution.
- 11.1.4.4. Add enough concentrated  $\text{NH}_4\text{OH}$  with a squeeze bottle to reach the phenolphthalein end point and form  $\text{Ca}_3(\text{PO}_4)_2$  precipitate.  $\text{NH}_4\text{OH}$  should be added very slowly. Stir the solution with a glass rod. Allow the sample to heat gently to digest the precipitate for another 20-30 minutes.
- 11.1.4.5. If the sample volume is too large to centrifuge the entire sample, allow precipitate to settle until solution can be decanted (30 minutes to 2 hours) and go to Step 11.1.4.7.
- 11.1.4.6. If the volume is small enough to centrifuge, go to Step 11.1.4.8.
- 11.1.4.7. Decant supernatant solution and discard to waste.
- 11.1.4.8. Transfer the precipitate to a 250-mL centrifuge tube, completing the transfer with a few milliliters of water, and centrifuging the precipitate for approximately 10 minutes at 2000 rpm.
- 11.1.4.9. Decant supernatant solution and discard to waste.
- 11.1.4.10. Wash the precipitate with an amount of water approximately twice the volume of the precipitate. Mix well using a stirring rod, breaking up the precipitate if necessary. Centrifuge for 5–10 minutes at 2000 rpm. Discard the supernatant solution.
- 11.1.4.11. Dissolve precipitate in approximately 5 mL concentrated  $\text{HNO}_3$ . Transfer solution to a 100-mL beaker. Rinse centrifuge tube with 2–3 mL of concentrated  $\text{HNO}_3$  and transfer to the same beaker. Evaporate solution to dryness and go to Step 11.2.
- 11.1.5. Evaporation option to reduce volume and to digest organic components
- 11.1.5.1. Evaporate sample to less than 50 mL and transfer to a 100-mL beaker.

**Note: For some water samples,  $\text{CaSO}_4$  formation may occur during evaporation. If this occurs, use the  $\text{Ca}_3(\text{PO}_4)_2$  precipitation option in Step 11.1.4.**

- 11.1.5.2. Gently evaporate the sample to dryness and redissolve in approximately 5 mL of concentrated  $\text{HNO}_3$ .
- 11.1.5.3. Repeat Step 11.1.5.2 two more times, evaporate to dryness, and go to Step 11.2.

## 11.2. Actinide Separations Using Eichrom Resins

### 11.2.1. Redissolve $\text{Ca}_3(\text{PO}_4)_2$ residue or evaporated water sample

11.2.1.1. Dissolve either residue with 10 mL of 3-M  $\text{HNO}_3$  - 1.0-M  $\text{Al}(\text{NO}_3)_3$ .

**Note:** An additional 5 mL may be necessary if the residue volume is large.

11.2.1.2. Add 2 mL of 0.6-M ferrous sulfamate to each solution. Swirl to mix.

**Note:** If the additional 5 mL was used to dissolve the sample in Step 11.2.1.1, add a total of 3 mL of ferrous sulfamate solution.

11.2.1.3. Add 1 drop of 1-M ammonium thiocyanate indicator to each sample and mix.

**Note:** The color of the solution turns deep red, due to the presence of soluble ferric thiocyanate complex.

11.2.1.4. Add 1 mL of 1-M ascorbic acid to each solution, swirling to mix. Wait for 2–3 minutes.

**Note:** The red color should disappear, which indicates reduction of  $\text{Fe}^{+3}$  to  $\text{Fe}^{+2}$ . If the red color still persists, then additional ascorbic acid solution has to be added drop-wise with mixing until the red color disappears.

**Note:** If particles are observed suspended in the solution, centrifuge the sample. The supernatant solution will be transferred to the column in Step 11.2.3.1. The precipitates will be discarded.

### 11.2.2. Setup of UTEVA and TRU cartridges in tandem on the vacuum box system

**Note:** Steps 11.2.2.1 to 11.2.2.5 deal with a commercially available filtration system. Other vacuum systems developed by individual laboratories may be substituted here as long as the laboratory has provided guidance to analysts in their use.

11.2.2.1. Place the inner tube rack (supplied with vacuum box) into the vacuum box with the centrifuge tubes in the rack. Fit the lid to the vacuum system box.

11.2.2.2. Place the yellow outer tips into all 24 openings of the lid of the vacuum box. Fit in the inner white tip into each yellow tip.

11.2.2.3. For each sample solution, fit in a TRU cartridge on to the inner white tip. Ensure the UTEVA cartridge is locked into the top end of the TRU cartridge.

11.2.2.4. Lock syringe barrels (funnels/reservoirs) to the top end of the UTEVA cartridge.

11.2.2.5. Connect the vacuum pump to the box. Turn the vacuum pump on and ensure proper fitting of the lid.

**IMPORTANT: The unused openings on the vacuum box should be sealed. Yellow caps (included with the vacuum box) can be used to plug unused white tips to achieve good seal during the separation.**

- 11.2.2.6. Add 5 mL of 3-M HNO<sub>3</sub> to the funnel to precondition the UTEVA and TRU cartridges.
- 11.2.2.7. Adjust the vacuum pressure to achieve a flow-rate of ~1 mL/min.

**IMPORTANT: Unless otherwise specified in the procedure, use a flow rate of ~1 mL/min for load and strip solutions and ~3 mL/min for rinse solutions.**

- 11.2.3. Preliminary purification of the americium fraction using UTEVA and TRU resins
  - 11.2.3.1. Transfer each solution from Step 11.2.1.4 into the appropriate funnel by pouring or by using a plastic transfer pipette. Allow solution to pass through both cartridges at a flow rate of ~1 mL/min.
  - 11.2.3.2. Add 5 mL of 3-M HNO<sub>3</sub> to each beaker (from Step 11.2.1.4) as a rinse and transfer each solution into the appropriate funnel (the flow rate can be adjusted to ~3 mL/min).
  - 11.2.3.3. Add 5 mL of 3-M HNO<sub>3</sub> into each funnel as a second column rinse (flow rate ~3 mL/min).
  - 11.2.3.4. Separate UTEVA cartridge from TRU cartridge. Discard UTEVA cartridge and the effluent collected so far. Place new funnel on the TRU cartridge.
- 11.2.4. Final americium separation using TRU cartridge

**Note: Steps 11.2.4.1 to 11.2.4.3 may be omitted if the samples are known not to contain plutonium**

- 11.2.4.1. Pipette 5 mL of 2-M HNO<sub>3</sub> into each TRU cartridge from Step 11.2.3.4. Allow to drain.
- 11.2.4.2. Pipette 5 mL of 2-M HNO<sub>3</sub> - 0.1-M NaNO<sub>2</sub> directly into each cartridge, rinsing each cartridge reservoir while adding the 2-M HNO<sub>3</sub> - 0.1-M NaNO<sub>2</sub>.

**IMPORTANT: The flow rate for the cartridge should be adjusted to ~1 mL/min for this step.**

**Note: Sodium nitrite is used to oxidize any Pu<sup>+3</sup> to Pu<sup>+4</sup> and enhance the Pu/Am separation.**

- 11.2.4.3. Allow the rinse solution to drain through each cartridge.
- 11.2.4.4. Add 5 mL of 0.5-M HNO<sub>3</sub> to each cartridge and allow it to drain.

**Note: 0.5-M HNO<sub>3</sub> is used to lower the nitrate concentration prior to conversion to the chloride system.**

- 11.2.4.5. Discard the load and rinse solutions to waste.
- 11.2.4.6. Ensure that clean, labeled tubes (at least 25-mL capacity) are placed in the tube rack.
- 11.2.4.7. Add 3 mL of 9-M HCl to each cartridge to convert to chloride system. Collect eluate.
- 11.2.4.8. Add 20 mL of 4-M HCl to elute americium. Collect eluate in the same tube.
- 11.2.4.9. Transfer the combined eluates from Steps 11.2.4.7 and 11.2.4.8 to a 50-mL beaker.
- 11.2.4.10. Rinse tube with a few milliliters of water and add to the same beaker.
- 11.2.4.11. Evaporate samples to near dryness.

**Important: Do not bake the residue.**

- 11.2.4.12. Allow the beaker to cool slightly and then add a few drops of concentrated HCl followed by 1 mL of water.
- 11.2.4.13. Transfer the solution from Step 11.2.4.12 to a 10-mL plastic culture tube. Wash the original sample vessel twice with 1-mL washes of 1M HCl. Transfer the washings to the culture tube. Mix by gently swirling the solution in the tube.
- 11.2.4.14. Proceed to neodymium fluoride microprecipitation in Step 11.3.
- 11.2.4.15. Discard the TRU cartridge.

### 11.3. Preparation of the Sample Test Source

**Note: Instructions below describe preparation of a single Sample Test Source. Several STSs can be prepared simultaneously if a multi-channel vacuum box (whale apparatus) is available.**

- 11.3.1. Add 100  $\mu$ L of the neodymium carrier solution to the tube from Step 11.2.4.14 with a micropipette. Gently swirl the tube to mix the solution.
- 11.3.2. Add 10 drops (0.5 mL) of concentrated HF to the tube and mix well by gentle swirling.
- 11.3.3. Cap the tube and place it in a cold-water bath for at least 30 minutes.
- 11.3.4. Insert the polysulfone filter stem in the 250-mL vacuum flask. Place the stainless steel screen on top of the fitted plastic filter stem.
- 11.3.5. Place a 25-mm polymeric filter face up on the stainless steel screen. Center the filter on the stainless steel screen support and apply vacuum. Wet the filter with 100% ethanol, followed by filtered Type I water.

**Caution: There is no visible difference between the two sides of the filter. If the filter is turned over accidentally, it is recommended that the filter be discarded and a fresh one removed from the container.**

- 11.3.6. Lock the filter chimney firmly in place on the filter screen and wash the filter with additional filtered Type I water.

- 11.3.7. Pour 5.0 mL of neodymium substrate solution down the side of the filter chimney, avoiding directing the stream at the filter. When the solution passes through the filter, wait at least 15 seconds before the next step.
- 11.3.8. Repeat Step 11.3.7 with an additional 5.0 mL of the substrate solution.
- 11.3.9. Pour the sample from Step 11.3.3 down the side of the filter chimney and allow the vacuum to draw the solution through.
- 11.3.10. Rinse the tube twice with 2 mL of 0.58 M HF, stirring each wash briefly using a vortex mixer, and pouring each wash down the side of the filter chimney.
- 11.3.11. Repeat rinse using 2 mL of filtered Type I water once.
- 11.3.12. Repeat rinse using 2 mL of 80% ethyl alcohol once.

**Note: Steps 11.3.10 and 11.3.12 were shown to improve the FWHM in the alpha spectrum, providing more consistent peak resolution.**

- 11.3.13. Wash any drops remaining on the sides of the chimney down toward the filter with a few milliliters of 80% ethyl alcohol.

**Caution: Directing a stream of liquid onto the filter will disturb the distribution of the precipitate on the filter and render the sample unsuitable for  $\alpha$ -spectrometry resolution.**

- 11.3.14. Without turning off the vacuum, remove the filter chimney.
- 11.3.15. Turn off the vacuum to remove the filter. Discard the filtrate to waste for future disposal. If the filtrate is to be retained, it should be placed in a plastic container to avoid dissolution of the glass vessel by dilute HF.
- 11.3.16. Place the filter on a properly labeled mounting disc. Secure with a mounting ring or other device that will render the filter flat for counting.
- 11.3.17. Let the sample air-dry for a few minutes and when dry, place in a container suitable for transfer and submit for counting.

**Note: Other methods for STS preparation, such as electroplating or microprecipitation with cerium fluoride, may be used in lieu of the neodymium fluoride microprecipitation, but any such substitution must be validated as described in Section 1.4.**

## 12. Data Analysis and Calculations

- 12.1. Equation for determination of final result, combined standard uncertainty, and radiochemical yield (if requested):

The activity concentration of an analyte and its combined standard uncertainty are calculated using the following equations:

$$AC_a = \frac{A_t \times R_a \times D_t \times I_t}{V_a \times R_t \times D_a \times I_a}$$

and

$$u_c(AC_a) = \sqrt{u^2(R_a) \times \frac{A_t^2 \times D_t^2 \times I_t^2}{V_a^2 \times R_t^2 \times D_a^2 \times I_a^2} + AC_a^2 \times \left( \frac{u^2(A_t)}{A_t^2} + \frac{u^2(V_a)}{V_a^2} + \frac{u^2(R_t)}{R_t^2} \right)}$$

where:

- $AC_a$  = activity concentration of the analyte at time of count, (pCi/L)
- $A_t$  = activity of the tracer added to the sample aliquant at its reference date/time, (pCi)
- $R_a$  = net count rate of the analyte in the defined region of interest (ROI), in counts per second
- $R_t$  = net count rate of the tracer in the defined ROI, in counts per second
- $V_a$  = volume of the sample aliquant, (L)
- $D_t$  = correction factor for decay of the tracer from its reference date and time to the midpoint of the counting period
- $D_a$  = correction factor for decay of the analyte from the time of sample collection (or other reference time) to the midpoint of the counting period, if required
- $I_t$  = probability of  $\alpha$  emission in the defined ROI per decay of the tracer (Table 17.1)
- $I_a$  = probability of  $\alpha$  emission in the defined ROI per decay of the analyte (Table 17.1)
- $u_c(AC_a)$  = combined standard uncertainty of the activity concentration of the analyte (pCi/L)
- $u(A_t)$  = standard uncertainty of the activity of the tracer added to the sample (pCi)
- $u(V_a)$  = standard uncertainty of the volume of sample aliquant (L)
- $u(R_a)$  = standard uncertainty of the net count rate of the analyte in counts per second
- $u(R_t)$  = standard uncertainty of the net count rate of the tracer in counts per second

**Note: The uncertainties of the decay-correction factors and of the probability of decay factors are assumed to be negligible.**

**Note: The equation for the combined standard uncertainty ( $u_c(AC_a)$ ) calculation is arranged to eliminate the possibility of dividing by zero if  $R_a = 0$ .**

**Note: The standard uncertainty of the activity of the tracer added to the sample must reflect that associated with the activity of the standard reference material and any other significant sources of uncertainty such as those introduced during the preparation of the tracer solution (e.g., weighing or dilution factors) and during the process of adding the tracer to the sample.**

**Note: The alpha spectrum of americium isotopes should be examined carefully and the ROI reset manually, if necessary, to minimize the spillover of  $^{241}\text{Am}$  peak into the  $^{243}\text{Am}$  peak.**

12.1.1. The net count rate of an analyte or tracer and its standard uncertainty can be calculated using the following equations:

$$R_x = \frac{C_x}{t_s} - \frac{C_{bx}}{t_b}$$

and

$$u(R_x) = \sqrt{\frac{C_x + 1}{t_s^2} + \frac{C_{bx} + 1}{t_b^2}}$$

where:

- $R_x$  = net count rate of analyte or tracer, in counts per second
- $C_x$  = sample counts in the analyte or the tracer ROI
- $t_s$  = sample count time (s)
- $C_{bx}$  = background counts in the same ROI as for x
- $t_b$  = background count time (s)
- $u(R_x)$  = standard uncertainty of the net count rate of tracer or analyte, in counts per second<sup>1</sup>

If the radiochemical yield of the tracer is requested, the yield and its combined standard uncertainty can be calculated using the following equations:

$$RY = \frac{R_t}{0.037 \times A_t \times D_t \times I_t \times \varepsilon}$$

and

$$u(RY) = RY \times \sqrt{\frac{u^2(R_t)}{R_t^2} + \frac{u^2(A_t)}{A_t^2} + \frac{u^2(\varepsilon)}{\varepsilon^2}}$$

where:

- $RY$  = radiochemical yield of the tracer, expressed as a fraction
- $R_t$  = net count rate of the tracer, in counts per second
- $A_t$  = activity of the tracer added to the sample (pCi)
- $D_t$  = correction factor for decay of the tracer from its reference date and time to the midpoint of the counting period
- $I_t$  = probability of  $\alpha$  emission in the defined ROI per decay of the tracer (Table 17.1)
- $\varepsilon$  = detector efficiency, expressed as a fraction
- $u_c(RY)$  = combined standard uncertainty of the radiochemical yield
- $u(R_t)$  = standard uncertainty of the net count rate of the tracer, in counts per second
- $u(A_t)$  = standard uncertainty of the activity of the tracer added to the sample (pCi)

---

<sup>1</sup> For methods with very low counts, MARLAP Section 19.5.2.2 recommends adding one count each to the gross counts and the background counts when estimating the uncertainty of the respective net counts. This minimizes negative bias in the estimate of uncertainty and protects against calculating zero uncertainty when a total of zero counts are observed for the sample and background.

$u(\varepsilon)$  = standard uncertainty of the detector efficiency

12.1.2. If the critical level concentration ( $S_c$ ) or the minimum detectable concentration (MDC) are requested (at an error rate of 5%), they can be calculated using the following equations:<sup>2</sup>

$$S_c = \frac{\left[ d \times \left( \frac{t_s}{t_b} - 1 \right) + \frac{z_{1-\alpha}^2}{4} \times \left( 1 + \frac{t_s}{t_b} \right) + z_{1-\alpha} \sqrt{\left( R_{ba} t_b + d \right) \times \frac{t_s}{t_b} \times \left( 1 + \frac{t_s}{t_b} \right)} \right] \times A_t \times D_t \times I_t}{t_s \times V_a \times R_t \times D_a \times I_a}$$

When the Type I decision error rate,  $\alpha$ , equals 0.05,  $z_{1-\alpha} = 1.645$ , and the constant,  $d$ , from the Stapleton approximation is set to 0.4, the expression above becomes:

$$S_c = \frac{\left[ 0.4 \times \left( \frac{t_s}{t_b} - 1 \right) + 0.677 \times \left( 1 + \frac{t_s}{t_b} \right) + 1.645 \times \sqrt{\left( R_{ba} t_b + 0.4 \right) \times \frac{t_s}{t_b} \times \left( 1 + \frac{t_s}{t_b} \right)} \right] \times A_t \times D_t \times I_t}{t_s \times V_a \times R_t \times D_a \times I_a}$$

$$\text{MDC} = \frac{\left[ \frac{\left( z_{1-\alpha} + z_{1-\beta} \right)^2}{4} \times \left( 1 + \frac{t_s}{t_b} \right) + \left( z_{1-\alpha} + z_{1-\beta} \right) \times \sqrt{R_{ba} t_s \times \left( 1 + \frac{t_s}{t_b} \right)} \right] \times A_t \times D_t \times I_t}{t_s \times V_a \times R_t \times D_a \times I_a \times 2.22}$$

When the Type I decision error rate,  $\alpha$ , equals 0.05,  $z_{1-\alpha} = 1.645$ , and the Type II decision error rate,  $\beta$ , equals 0.05,  $z_{1-\beta} = 1.645$ , the expression above becomes:

$$\text{MDC} = \frac{\left[ 2.71 \times \left( 1 + \frac{t_s}{t_b} \right) + 3.29 \times \sqrt{R_{ba} t_s \times \left( 1 + \frac{t_s}{t_b} \right)} \right] \times A_t \times D_t \times I_t}{t_s \times V_a \times R_t \times D_a \times I_a}$$

where:

<sup>2</sup> The formulations for the critical level and minimum detectable concentrations are as recommended in MARLAP Section 20A.2.2, Equation 20.54, and Section 20A.3.2, Equation 20.74, respectively. For methods with very low numbers of counts, these expressions provide better estimates than do the traditional formulas for the critical level and MDC assuming that the observed variance of the background conforms to Poisson statistics. Consult MARLAP when background variance may exceed that predicted by the Poisson model or when other decision error rates may apply.



$R_{ba}$  = background count rate for the analyte in the defined ROI, in counts per second

## 12.2. Results Reporting

12.2.1. The following items should be reported for each result: volume of sample used; yield of tracer and its uncertainty; and full width at half maximum (FWHM) of each peak used in the analysis.

12.2.2. The following conventions should be used for each result:

12.2.2.1. Result in scientific notation  $\pm$  combined standard uncertainty.

12.2.2.2. If solid material was filtered from the solution and analyzed separately, the results of that analysis should be reported separately as pCi/L of the original volume from which the solids were filtered if no other guidance is provided on reporting of results for the solids. For example:

$^{241}\text{Am}$  for Sample 12-1-99:

Filtrate Result:  $(1.28 \pm 0.15) \times 10^1$  pCi/L

Filtered Residue Result:  $(2.50 \pm 0.32) \times 10^0$  pCi/L

## 13. Method Performance

13.1. Method validation results are to be reported as an attachment.

13.1.1. Expected turnaround time per batch of 14 samples plus QC, assuming microprecipitations for the whole batch are performed simultaneously using a vacuum box system:

13.1.2. For an analysis of a 200-mL sample aliquant, sample preparation and digestion should take 3.5 h.

13.1.3. Purification and separation of the americium fraction using cartridges and vacuum box system should take 2.5 h.

13.1.4. Sample evaporation to near dryness should take ~ 30 minutes.

13.1.5. The last step of source preparation takes ~1 h.

13.1.6. A 1–3 h counting time is sufficient to meet the MQOs listed in 9.3 and 9.4, assuming detector efficiency of 0.2–0.3, and radiochemical yield of at least 0.5. Longer counting time may be necessary to meet these MQOs if detector efficiency is lower.

13.1.7. Data should be ready for reduction between 8.5 and 10.5 h after beginning of analysis.

14. Pollution Prevention: This method utilizes small volume (2-mL) extraction chromatographic resin columns. This approach leads to a significant reduction in the volumes of load, rinse and strip solutions, as compared to classical methods using ion exchange resins to separate and purify the americium fraction.

## 15. Waste Management

15.1. Types of waste generated per sample analyzed

15.1.1. If  $\text{Ca}_3(\text{PO}_4)_2$  coprecipitation is performed, approximately 100–1000 mL of decanted solution that is pH neutral are generated.

- 15.1.2. Approximately 35 mL of acidic waste from loading and rinsing the two extraction columns are generated.
  - 15.1.3. Approximately 35 mL of acidic waste from microprecipitation method for source preparation, contains 1 mL of HF and ~ 8 mL ethanol.
  - 15.1.4. Unless processed further, the UTEVA cartridge may contain isotopes of uranium, neptunium, and thorium, if any of these were present in the sample originally.
  - 15.1.5. Unless processed further, the TRU cartridge may contain isotopes of plutonium if any of them were present in the sample originally.
  - 15.2. Evaluate all waste streams according to disposal requirements by applicable regulations.
16. References
- 16.1. ACW03 VBS, Rev. 1.6, "Americium, Plutonium, and Uranium in Water (with Vacuum Box System)," Eichrom Technologies, Inc., Lisle, Illinois (February 2005).
  - 16.2. G-03, V.1 "Microprecipitation Source Preparation for Alpha Spectrometry," HASL-300, 28th Edition, (February 1997).
  - 16.3. ASTM D7282 "Standard Practice for Set-up, Calibration, and Quality Control of Instruments Used for Radioactivity Measurements," ASTM Book of Standards 11.02, current version, ASTM International, West Conshohocken, PA.
  - 16.4. VBS01, Rev.1.3, "Setup and Operation Instructions for Eichrom's Vacuum Box System (VBS)," Eichrom Technologies, Inc., Lisle, Illinois (January 2004).
  - 16.5. U.S. Environmental Protection Agency (EPA). 2009. *Method Validation Guide for Radiological Laboratories Participating in Incident Response Activities*. Revision 0. Office of Air and Radiation, Washington, DC. EPA 402-R-09-006, June. Available at: [www.epa.gov/narel/incident\\_guides.html](http://www.epa.gov/narel/incident_guides.html) and [www.epa.gov/erln/radiation.html](http://www.epa.gov/erln/radiation.html).
  - 16.6. *Multi-Agency Radiological Laboratory Analytical Protocols Manual (MARLAP)*. 2004. EPA 402-B-1304 04-001A, July. Volume I, Chapters 6, 7, 20, Glossary; Volume II and Volume III, Appendix G. Available at: [www.epa.gov/radiation/marlap/index.html](http://www.epa.gov/radiation/marlap/index.html).
  - 16.7. ASTM D1193, "Standard Specification for Reagent Water" ASTM Book of Standards 11.01, current version, ASTM International, West Conshohocken, PA.

## 17. Tables, Diagrams, Flow Charts, and Validation Data

## 17.1. Tables [including major radiation emissions from all radionuclides separated]

**Table 17.1 Alpha Particle Energies and Abundances of Importance<sup>[1]</sup>**

<b>Nuclide</b>	<b>Half-Life (Years)</b>	<b><math>\lambda</math> (s<sup>-1</sup>)</b>	<b>Abundance</b>	<b><math>\alpha</math> Energy (MeV)</b>
<sup>241</sup> Am	432.6	$5.077 \times 10^{-11}$	0.848	5.486
			0.131	5.443
			0.0166	5.388
<sup>243</sup> Am	$7.37 \times 10^3$	$2.98 \times 10^{-12}$	0.871	5.275
			0.112	5.233
			0.0136	5.181

<sup>[1]</sup> Only the most abundant particle energies and abundances have been noted here.

17.2. Ingrowth Curves and Ingrowth Factors

*This section intentionally left blank*

17.3. Spectrum from a Processed Sample

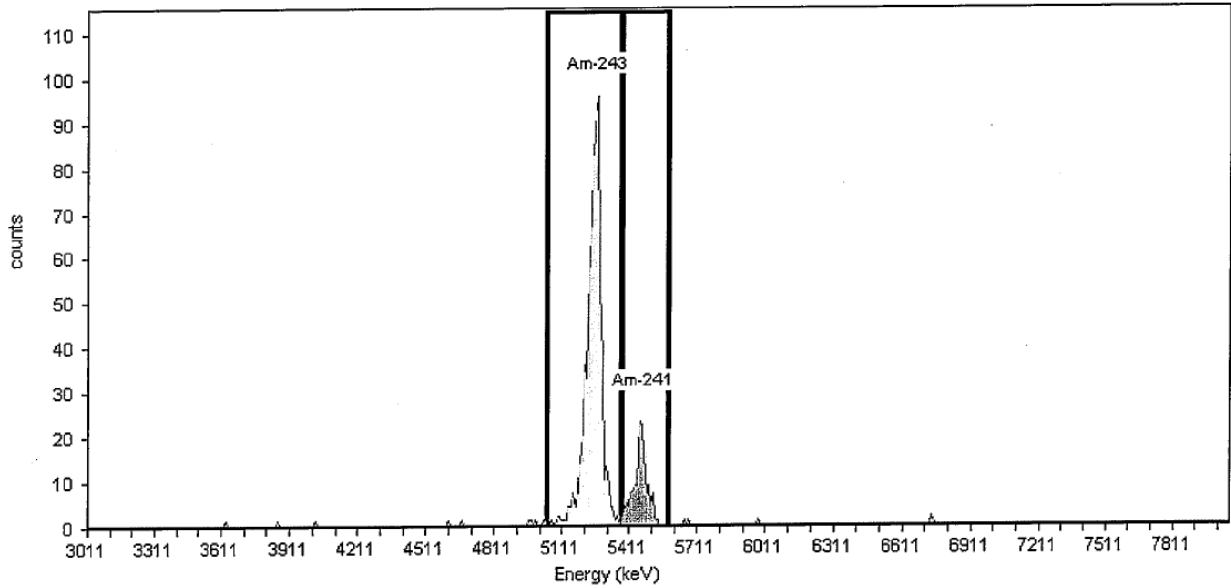

17.2 Decay Scheme

**<sup>241</sup>Am and <sup>243</sup>Am Decay Scheme**

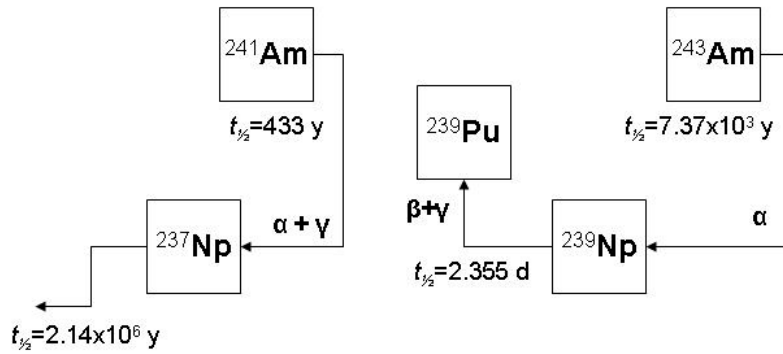

17.4. Flow Chart

