

EPA 204-R-14-009  
[www.epa.gov/narel](http://www.epa.gov/narel)  
September 2014

**Validation of  
Rapid Radiochemical Method  
for Pu-238 and Pu-239/240  
in Brick Samples  
for Environmental Remediation Following  
Radiological Incidents**

**U.S. Environmental Protection Agency**

**Office of Air and Radiation  
Office of Radiation and Indoor Air  
National Analytical Radiation Environmental Laboratory  
Montgomery, AL 36115**

**Office of Research and Development National  
Homeland Security Research Center  
Cincinnati, OH 45268**

This report was prepared for the National Analytical Radiation Environmental Laboratory of the Office of Radiation and Indoor Air and the National Homeland Security Research Center of the Office of Research and Development, United States Environmental Protection Agency (EPA). It was prepared by Environmental Management Support, Inc., of Silver Spring, Maryland, under contract EP-W-13-016, Task Order 0014, managed by Dan Askren. This document has been reviewed in accordance with EPA policy and approved for publication. Note that approval does not signify that the contents necessarily reflect the views of the Agency. Mention of trade names, products, or services does not convey EPA approval, endorsement, or recommendation.

## Contents

Acronyms, Abbreviations, Units, and Symbols.....	iii
Radiometric and General Unit Conversions .....	v
1. Introduction .....	1
2. Radioanalytical Methods .....	2
3. Method Validation Process Summary .....	2
4. Participating Laboratory .....	4
5. Measurement Quality Objectives .....	4
6. Method Validation Plan.....	5
6.1 Method Uncertainty .....	5
6.2 Detection Capability.....	5
6.3 Method Bias .....	6
6.4 Analyte Concentration Range .....	7
6.5 Method Specificity .....	7
6.6 Method Ruggedness .....	8
7. Techniques Used to Evaluate the Measurement Quality Objectives for the Rapid Methods Development Project .....	8
7.1 Required Method Uncertainty.....	8
7.2 Required Minimum Detectable Concentration .....	9
8. Evaluation of Experimental Results .....	10
8.1 Summary of the Combined Rapid <sup>239/240</sup> Pu - Brick Method .....	10
8.2 Required Method Uncertainty.....	11
8.3 Required Minimum Detectable Concentration .....	12
8.4 Evaluation of the Absolute and Relative Bias .....	14
8.5 Method Ruggedness and Specificity .....	15
9. Timeline to Complete a Batch of Samples .....	16
10. Reported Modifications and Recommendations .....	17
11. Summary and Conclusions .....	17
12. References .....	18
Attachment I: Estimated Elapsed Times.....	19
Attachment II: Rapid Method for Sodium Hydroxide Fusion of Concrete and Brick Matrices Prior to Americium, Plutonium, Strontium, Radium, and Uranium Analyses for Environmental Remediation Following Radiological Incidents .....	20
Appendix: Rapid Technique for Milling and Homogenizing Concrete and Brick Samples .....	41
Attachment III: Rapid Radiochemical Method for Pu-238 and Pu-239/240 in Building Materials for Environmental Remediation Following Radiological Incidents.....	50
Attachment IV: Composition of Brick Used for Spiking in this Study.....	68

**Figure**

Figure 1 – Yields for Method Based on Measurement of <sup>242</sup>Pu ..... 16

**Tables**

Table 1 – Pu-239/240 Method Validation Test Concentrations and Results ..... 4  
Table 2 – Sample Identification and Test Concentration Level for Evaluating the Required  
Minimum Detectable Concentration..... 5  
Table 3 – MARLAP Level C Acceptance Criteria ..... 9  
Table 4A – Pu-239/240 Analytical Results for Required Method Uncertainty Evaluation ..... 11  
Table 4B – Experimental Standard Deviation of the Five PT Samples by Test Level..... 12  
Table 5 – Reported <sup>239/240</sup>Pu Concentration Blank Brick Samples ..... 12  
Table 6 – Reported Results for Samples Containing <sup>239/240</sup>Pu at the As-Tested MDC Value  
(0.2040 pCi/g)..... 14  
Table 7 – Absolute and Relative Bias Evaluation of the Combined Rapid <sup>239</sup>Pu - Brick Method  
..... 15  
Table 8 – Summary of <sup>242</sup>Pu Radiochemical % Yield Results for Test and Quality Control  
Samples..... 16

## Acronyms, Abbreviations, Units, and Symbols

AAL	analytical action level
ACS	American Chemical Society
APS	analytical protocol specification
Bq	becquerel
$CL_{NC}$	critical net concentration
CSU	combined standard uncertainty
Ci	curie
d	day
DL	discrimination level
dpm	disintegrations per minute
dps	disintegrations per second
DQO	data quality objective
DRP	discrete radioactive particle
E&Z	Eckert & Ziegler Analytics
EPA	U.S. Environmental Protection Agency
FRMAC	Federal Radiological Monitoring and Assessment Center
ft	foot
FWHM	full width at half maximum
g	gram
gal	gallon
G-M	Geiger-Muller [counter or probe]
h	hour
ICP-AES	inductively coupled plasma – atomic emission spectrometry
ID	identifier/identification number
IND	improvised nuclear device
IUPAC	International Union of Pure and Applied Chemistry
kg	kilogram ( $10^3$ gram)
L	liter
$L_c$	critical level
LCS	laboratory control sample
m	meter
M	molar
MARLAP	<i>Multi-Agency Radiological Laboratory Analytical Protocols Manual</i>
MDC	minimum detectable concentration
MeV	million electron volts ( $10^6$ electron volts)
mg	milligram ( $10^{-3}$ gram)
min	minute
mL	milliliter ( $10^{-3}$ liter)
mm	millimeter ( $10^{-3}$ meter)
MQO	measurement quality objective
MVRM	method validation reference material
$\mu\text{Ci}$	microcurie ( $10^{-6}$ curie)
$\mu\text{m}$	micrometer ( $10^{-6}$ meter)
NAREL	EPA's National Analytical Radiation Environmental Laboratory, Montgomery, Alabama

NHSRC .....EPA's National Homeland Security Research Center, Cincinnati, Ohio  
NIST.....National Institute of Standards and Technology  
ORIA.....U.S. EPA Office of Radiation and Indoor Air  
 $\phi_{mr}$ .....required relative method uncertainty  
pCi.....picocurie ( $10^{-12}$  curie)  
PPE.....personal protective equipment  
ppm.....parts per million  
PT.....proficiency test or performance test  
QAPP .....quality assurance project plan  
R.....Roentgen – unit of X or  $\gamma$  radiation exposure in air  
rad .....unit of radiation absorbed dose in any material  
RDD .....radiological dispersal device  
rem .....roentgen equivalent: man  
ROI.....region of interest  
s.....second  
SI.....International System of Units  
Sv.....sievert  
 $u_{mr}$ .....required method uncertainty  
wt% .....percent by mass  
y.....year

### Radiometric and General Unit Conversions

To Convert	To	Multiply by	To Convert	To	Multiply by
years (y)	seconds (s)	$3.16 \times 10^7$	s	y	$3.17 \times 10^{-8}$
	minutes (min)	$5.26 \times 10^5$	min		$1.90 \times 10^{-6}$
	hours (h)	$8.77 \times 10^3$	h		$1.14 \times 10^{-4}$
	days (d)	$3.65 \times 10^2$	d		$2.74 \times 10^{-3}$
disintegrations per second (dps)	becquerel (Bq)	1	Bq	dps	1
Bq	picocurie (pCi)	27.0	pCi	Bq	$3.70 \times 10^{-2}$
Bq/kilogram (kg)	pCi/gram (g)	$2.70 \times 10^{-2}$	pCi/g	Bq/kg	37.0
Bq/cubic meters (m <sup>3</sup> )	pCi/g	$2.70 \times 10^{-2}$	pCi/g	Bq/m <sup>3</sup>	37.0
Bq/m <sup>3</sup>	Bq/L	$10^{-3}$	Bq/L	Bq/m <sup>3</sup>	$10^3$
microcuries per milliliter (μCi/mL)	pCi/g	$10^9$	pCi/g	μCi/mL	$10^{-9}$
disintegrations per minute (dpm)	μCi	$4.50 \times 10^{-7}$	pCi	dpm	2.22
	pCi	$4.50 \times 10^{-1}$			
cubic feet (ft <sup>3</sup> )	m <sup>3</sup>	$2.83 \times 10^{-2}$	m <sup>3</sup>	ft <sup>3</sup>	35.3
gallons (gal)	liters (L)	3.78	L	gal	0.264
gray (Gy)	rad	$10^2$	rad	Gy	$10^{-2}$
roentgen equivalent: man (rem)	sievert (Sv)	$10^{-2}$	Sv	rem	$10^2$

NOTE: Traditional units are used throughout this document instead of the International System of Units (SI). Conversion to SI units will be aided by the unit conversions in this table.

## **Acknowledgments**

The U.S. Environmental Protection Agency's (EPA's) Office of Radiation and Indoor Air's (ORIA) National Analytical Radiation Environmental Laboratory (NAREL), in conjunction with the EPA Office of Research and Development's National Homeland Security Research Center (NHSRC) developed this method validation report. Dr. John Griggs served as project lead. Several individuals provided valuable support and input to this document throughout its development. Special acknowledgment and appreciation are extended to Kathleen M. Hall, of NHSRC.

We also wish to acknowledge the valuable suggestions provided by the staff of NAREL, who conducted the method validation studies. Dr. Keith McCroan, of NAREL, provided significant assistance with the equations used to calculate minimum detectable concentrations and critical levels. Numerous other individuals, both inside and outside of EPA, provided comments and criticisms of this method, and their suggestions contributed greatly to the quality, consistency, and usefulness of the final method. Environmental Management Support, Inc. provided technical support.



## 1. Introduction

Rapid methods need to be developed and validated for processing samples taken in response to a radiological incident. In order to address this need, a project was initiated to develop rapid methods that can be used to prioritize environmental sample processing as well as provide quantitative results that meet measurement quality objectives (MQOs) that apply to the intermediate and recovery phases of an incident.<sup>1</sup> Similar to the rapid method project initiated in 2007 for other radionuclides in water samples (EPA 2008), this rapid method development project for a brick matrix addressed four different radionuclides in addition to  $^{238}\text{Pu}$  +  $^{239/240}\text{Pu}$ :  $^{241}\text{Am}$ ,  $^{\text{nat}}\text{U}$ ,  $^{226}\text{Ra}$ , and  $^{90}\text{Sr}$ . Each of these radionuclides will have separate method validation reports for the brick matrix.

The method validation plan developed for the rapid methods project follows the guidance in *Method Validation Guide for Qualifying Methods Used by Radiological Laboratories Participating in Incident Response Activities* (EPA 2009), *Validation and Peer Review of U.S. Environmental Protection Agency Radiochemical Methods of Analysis* (2006), and Chapter 6 of *Multi-Agency Radiological Laboratory Analytical Protocols Manual (MARLAP)* (EPA 2004). The method was evaluated according to MARLAP method validation “Level C.” The method formulated was preliminarily tested at EPA’s National Analytical Radiation Environmental Laboratory (NAREL) and refinements to the method made according to the feedback from the laboratory and the quality of the generated results. For the method validation process, the laboratory analyzed several sets of blind proficiency test (PT) samples according to specifications that meet established MQOs and guidance outlined in *Radiological Sample Analysis Guide for Radiological Incidents — Radionuclides in Soil* (EPA 2012). The MQO specification for the required method uncertainty ( $u_{\text{MR}}$ ) of 0.20 pCi/g was based on a  $^{239}\text{Pu}$  brick concentration similar to the MQO for the soil matrix, i.e., at approximately  $1 \times 10^{-5}$  risk limit for a 50-year exposure of 1.5 pCi/g.

This report provides a summary of the results of the method validation process for a combination of two methods; *Rapid Method for Sodium Hydroxide Fusion of Concrete and Brick Matrices Prior to Americium, Plutonium, Strontium, Radium, and Uranium Analyses for Environmental Remediation Following Radiological Incidents* (Attachment II) and *Rapid Radiochemical Method for Pu-238 and Pu-239/240 in Building Materials for Environmental Remediation Following Radiological Incidents* (Attachment III). Although the method validation presented here is for  $^{239/240}\text{Pu}$  only, similar results would be expected for  $^{238}\text{Pu}$ . In this document, the combined methods are referred to as “combined rapid  $^{239}\text{Pu}$  - Brick method.” The method validation process is applied to the fusion dissolution of brick using sodium hydroxide, the subsequent separation of plutonium using extraction chromatography, and the quantitative analysis of  $^{239}\text{Pu}$  using alpha spectrometry to detect the 5.106 MeV (11.9%), 5.144 MeV (17.1%), and 5.157 MeV (70.8%) alpha particles from the decay of  $^{239}\text{Pu}$ . Pu-242 was used as a tracer to quantify the chemical yield and account for overall detection efficiency. The laboratory’s complete report, including a case narrative and a compilation of the reported results for this study, can be obtained by contacting EPA’s NAREL (<http://www.epa.gov/narel/contactus.html>).

---

<sup>1</sup> ORIA and the Office of Research and Development jointly undertook the rapid methods development projects. The MQOs were derived from Protective Action Guides determined by ORIA.

## 2. Radioanalytical Methods

The combined rapid  $^{239}\text{Pu}$  - Brick method was written in a format consistent with EPA guidance and conventions. The rapid method was formulated to optimize analytical throughput for sample preparation, fusion process, chemical processing, and radiation detection. The final step of this method prepares the sample for separation and analysis by the “*Rapid Radiochemical Method for Pu-239/240 in Building Materials for Environmental Remediation Following Radiological Incidents*” (Attachment III). Specifications for sample processing were incorporated into the rapid method. These specifications are reflected in the scope and application and in the body of the methods. The specifications include the use of a radiotracer yield monitor and the required method uncertainty. Known interferences are addressed in Section 4 of the attached method (Attachment III). For this validation study, the laboratory used a 500-minute counting time for three test level samples and a 360-minute counting time for the required minimum detectable concentration (MDC) samples. A 1-g sample of the brick matrix was processed. A summary of the rapid method is presented in Section 8.1 prior to presenting the experimental results of the method validation analyses.

The final combined rapid  $^{239}\text{Pu}$  - Brick method is included as Attachments II and III to this report. The validation process was performed using the final combined method in the attachments.

## 3. Method Validation Process Summary

The method validation plan for the combined rapid  $^{239}\text{Pu}$  - Brick method containing  $^{239}\text{Pu}$  follows the guidance provided in *Method Validation Guide for Qualifying Methods Used by Radiological Laboratories Participating in Incident Response Activities* (EPA 2009), *Validation and Peer Review of U.S. Environmental Protection Agency Radiochemical Methods of Analysis* (EPA 2006), and Chapter 6 of MARLAP (2004). This method validation process was conducted under the generic *Quality Assurance Project Plan Validation of Rapid Radiochemical Methods for Radionuclides Listed in EPA’s Standardized Analytical Methods (SAM) for Use During Homeland Security Events* (EPA 2011). The combined rapid  $^{239}\text{Pu}$  - Brick method is considered a “new application/similar matrix” of an existing  $^{238}\text{Pu}$  and  $^{239}\text{Pu}$  method for soil and concrete matrices (EPA 2004, Section 6.6.3.5). Therefore, the combined rapid  $^{239}\text{Pu}$  - Brick method was evaluated according to MARLAP method validation “Level C.” More specifically, the method was validated against acceptance criteria for the required method uncertainty ( $u_{\text{mr}}$ ) at a specified analytical action level (AAL) concentration and the required MDC. In addition, analytical results were evaluated for statistical bias, absolute bias for blank samples and relative bias at each of the three test level radionuclide activities. The radiochemical yield of the method was also evaluated as a characteristic of method ruggedness.

The method validation process was divided into four phases:

1. Phase I
  - a. Laboratory familiarization with the method concept.
  - b. Set-up of the laboratory and acquisition of reagents, standards and preparation of in-house PT samples.

- c. Perform preliminary tests of the rapid fusion method.
  - d. Make changes to improve the method based on the preliminary tests.
2. Phase II
  - a. Conduct blank sample analyses to assess the method critical level concentration.
  - b. Conduct method validation for required method uncertainty.
3. Phase III
  - a. Conduct verification of the required MDC.
4. Phase IV
  - a. Report results.
  - b. Laboratory writes report to describe the process and narratives on the method.
  - c. Review and comment on method.
  - d. Environmental Management Support, Inc., writes method validation report, which is reviewed by laboratory.

During Phases I, II, and III, the laboratory processed and evaluated batch quality control samples according to their laboratory quality manual, including an analytical reagent blank, laboratory control sample (LCS) and a sample duplicate.

The objective of the first (preliminary) phase was to familiarize the laboratory with the formulated rapid method and then gain hands-on experience in using the rapid method to identify areas that might require optimization. During this phase, the laboratory processed samples of blank brick material and blank brick that was spiked in-house with  $^{239}\text{Pu}$  activities consistent with evaluating the targeted required method uncertainty at the AAL and the required MDC (see “Pu-239 Method Validation Test Concentrations and Results,” Table 1). The analysis of the blank and laboratory spiked brick samples used in Phase I provided insight into the feasibility of the proposed method. Based on information and experience gained during Phase I practice runs, the combined rapid  $^{239}\text{Pu}$  - Brick method was optimized without compromising data collected during the validation process in Phases II and III. The method was not subjected to a “formal” method validation evaluation process in Phase I.

During Phases II and III of the method validation process, the laboratory analyzed external PT samples provided by an external, National Institute of Standards and Technology (NIST)-traceable source manufacturer (Eckert & Ziegler Analytics (E&Z), Atlanta, GA). The PT samples were pulverized brick prepared by E&Z. The macro-analysis of brick material is provided in Attachment IV. The laboratory was instructed to analyze specific blind PT samples having concentration levels consistent with validation test levels for the required method uncertainty and the required MDC. The test levels of the PT samples are listed in Tables 1 and 2. Following completion of the method validation studies, comments from the laboratory were evaluated, and the method revised to conform to the documented “as-tested” conditions in Phases II and III. Thus the validation data presented in this report reflect the combined final method included in the attachments to this document.

#### 4. Participating Laboratory

EPA's National Analytical Radiation Environmental Laboratory, Montgomery, AL, validated the rapid fusion of brick samples using chemically characterized brick samples spiked with NIST-traceable  $^{239}\text{Pu}$  sources.

#### 5. Measurement Quality Objectives

The combined rapid  $^{239/240}\text{Pu}$  - Brick method was developed to meet pre-established MQOs for the rapid methods project. The selected MQOs included the radionuclide concentration range, the required method uncertainty at a specified radionuclide concentration (e.g., AAL), and the required MDC. The required relative method uncertainty ( $\phi_{\text{MR}}$ ) for the combined rapid  $^{239/240}\text{Pu}$  - Brick method was set at 13%<sup>2</sup> at a targeted brick analytical action level equal to 1.8 pCi/g, which is approximately the  $1 \times 10^{-5}$  risk concentration for a 50-year exposure period for a soil matrix. This soil concentration value is based on guidance found in the Federal Radiological Monitoring and Assessment Center (FRMAC).<sup>2</sup> The target MDC for the rapid  $^{239/240}\text{Pu}$  method for the brick matrix was 0.2 pCi/g (~11 % of the AAL) (see Attachment IV for the chemical composition of the brick matrix). However, the PT sample supplier generated method validation and MDC samples having  $^{239}\text{Pu}$  concentrations slightly different than the targeted values. Table 1 summarizes the targeted MQOs for the  $^{239}\text{Pu}$  method validation process and the study test values based on the actual spiked concentrations of the PT samples. It should be noted that the method was validated for a brick matrix having a typical chemical composition and four additional radionuclides in concentrations corresponding to a  $10^{-5}$  risk analytical action level for soil. The brick concentration for the four other radionuclides were  $^{241}\text{Am}$  (1.57 pCi/g),  $^{238}\text{U}$  (12.4 pCi/g),  $^{226}\text{Ra}$  (4.76 pCi/g), and  $^{90}\text{Sr}$  (2.44 pCi/g). The PT sample supplier provided test data for 10 1-g samples that documents the spread in the spike in the samples as a 1.59 % standard deviation in the distribution of results.

**Table 1 – Pu-239/240 Method Validation Test Concentrations and Results**

	Target Value	Known Value, pCi/g ( $k=1$ )	Average Measured Value	Required Method Uncertainty, $u_{\text{MR}}$	Standard Deviation of Measurements <sup>2</sup>
MDC	0.20	0.2040 ± 0.0020	0.198	—	0.033
$\frac{1}{2} \times \text{AAL}$	0.75	0.9280 ± 0.0093	0.945	0.25	0.044
AAL	1.5	1.890 ± 0.019	1.89	0.25	0.12
$3 \times \text{AAL}$	4.5	5.770 ± 0.058	5.57	0.75 <sup>[1]</sup>	0.21

[1] The value of 0.75 pCi/g is the absolute value for the required method uncertainty and represents 13% of 5.77 pCi/g.

[2] Calculated standard deviation of the 10 and 5 measurement results for the MDC and Test Level samples, respectively

<sup>2</sup> Type I and II decision error rates were set at  $z_{1-\alpha} = 0.01$  and  $z_{1-\beta} = 0.05$ . The required method uncertainty is calculated using the formula,  $u_{\text{MR}} = (\text{AAL}-\text{DL})/[z_{1-\alpha} + z_{1-\beta}]$  where the analytical action level (AAL) is as noted above and the discrimination level (DL) is  $\frac{1}{2}$  of the AAL.

<sup>2</sup> Federal Radiological Monitoring and Assessment Center. Appendix C of the FRMAC Manual (FRMAC 2010) or calculated using TurboFRMAC 2010 available from Sandia National Laboratory.

## 6. Method Validation Plan

The combined rapid  $^{239/240}\text{Pu}$  – Brick method was evaluated for the six important performance characteristics for radioanalytical methods specified in *Quality Assurance Project Plan Validation of Rapid Radiochemical Methods for Radionuclides Listed in EPA’s Standardized Analytical Methods (SAM) for Use During Homeland Security Events* (EPA 2011). These characteristics include method uncertainty, detection capability, bias, analyte activity range, method ruggedness, and method specificity. A summary of the manner in which these performance characteristics were evaluated is presented below. The chemical yield of the method, an important characteristic for method ruggedness, was also evaluated.

### 6.1 Method Uncertainty

The method uncertainty of the combined rapid  $^{239/240}\text{Pu}$  - Brick method was evaluated at the AAL concentration (1.890 pCi/g known value) specified in the MQOs presented in Table 1. In accordance with MARLAP method validation “Level C,” this is a similar matrix as the combined rapid methods for  $^{239/240}\text{Pu}$  in concrete and was evaluated at each of three test concentration levels, one of which was the AAL equivalent activity concentration to approximately  $1 \times 10^{-5}$  risk for a soil matrix. The laboratory analyzed five replicate external PT samples containing  $^{239}\text{Pu}$  activities at approximately one-half the AAL, the AAL and three times the AAL. The method was evaluated against the required method uncertainty,  $u_{\text{MR}} = 0.25$  pCi/g, at and below the AAL, and against the relative required method uncertainty,  $\phi_{\text{MR}} = 13\%$  of the known test value, above the AAL. The test level concentrations analyzed are listed in Table 1 “Known Value.”

### 6.2 Detection Capability

The detection capability of the combined rapid  $^{239/240}\text{Pu}$  - Brick method was evaluated to meet a required MDC of 0.2040 pCi/g as specified in Table 2. In accordance with the guidance provided in *Method Validation Guide for Radiological Laboratories Participating in Incident Response Activities* (EPA 2009), the laboratory estimated the critical net concentration based on the results of seven reagent blank samples. Results from 10 replicate samples having an “as tested” concentration at the required MDC were compared to the critical net concentration to determine method detection capability.

**Table 2 – Sample Identification and Test Concentration Level for Evaluating the Required Minimum Detectable Concentration**

Test Sample Designation	Number of Samples Prepared	Nuclide	MDC Known Value (pCi/g)	Mean Measured Concentration (pCi/g) <sup>[1]</sup>
P30-P39 (Brick MDC samples)	10	$^{239/240}\text{Pu}$	$0.2040 \pm 0.0020$ ( $k = 1$ )	$0.198 \pm 0.033$ ( $k = 1$ )
P41-P47 (Brick <sup>2</sup> matrix blanks)	7	$^{239/240}\text{Pu}$	—	$-0.0003 \pm 0.0041$

[1] Mean and standard deviation of 10 spiked samples and 7 blanks. The stated combined standard uncertainty (CSU) for the known value includes the uncertainty in the  $^{239}\text{Pu}$  reference standard used to prepare the samples. The concentration of  $^{239}\text{Pu}$  in the blank brick sample matrix was not statistically different than zero.

2] Blank brick matrix supplied by Eckert & Ziegler Analytics, Atlanta, Georgia.

### 6.3 Method Bias

Two types of method bias were evaluated, absolute and relative.

#### *Absolute Bias*

Absolute bias was determined as a method performance parameter. The results from the seven blank brick samples for the required MDC evaluation were evaluated for absolute bias according to the protocol and equation presented in the *Method Validation Guide for Qualifying Methods Used by Radiological Laboratories Participating in Incident Response Activities* (EPA 2009). There was no acceptance limit for bias established for the method in this method validation process.

The following protocol was used to test the combined rapid  $^{239/240}\text{Pu}$  - Brick method for absolute bias:

1. Calculate the mean ( $\bar{X}$ ) and estimated standard deviation ( $s_x$ ) for “N” (at least seven) blank sample net results.
2. Use the equation below to calculate the |T| value:

$$|T| = \frac{|\bar{X}|}{s_x / \sqrt{N}} \quad (1)$$

3. An absolute bias in the measurement process is indicated if

$$|T| > t_{1-\alpha/2}(N-1) \quad (2)$$

where  $t_{1-\alpha/2}(N-1)$  represents the  $(1 - \alpha/2)$ -quantile of the  $t$ -distribution with  $N-1$  degrees of freedom. For seven blanks, an absolute bias is identified at a significance level of 0.05, when  $|T| > 2.447$ .

#### *Relative Bias*

The results from the five external PT brick samples for each of the three test levels were evaluated for relative bias according to the protocol and equation presented in the *Method Validation Requirements for Qualifying Methods Used by Radioanalytical Laboratories Participating in Incident Response Activities*. No acceptable relative bias limit was specified for this method validation process.

The following protocol was used to test the combined rapid  $^{239/240}\text{Pu}$  - Brick method for relative bias:

1. Calculate the mean ( $\bar{X}$ ) and estimated standard deviation ( $s_x$ ) of the replicate results for each method validation test level.

2. Use the equation below to calculate the  $|T|$  value

$$|T| = \frac{|\bar{X} - K|}{\sqrt{s_x^2 / N + u^2(K)}} \quad (3)$$

where:

$\bar{X}$  is the average measured value

$s_x$  is the experimental standard deviation of the measured values

$N$  is the number of replicates

$K$  is the reference value

$u(K)$  is the standard uncertainty of the reference value

A relative bias in the measurement process is indicated if

$$|T| > t_{1-\alpha/2}(v_{\text{eff}}) \quad (3a)$$

The number of *effective degrees of freedom* for the  $T$  statistic is calculated as follows:

$$v_{\text{eff}} = (N - 1) \left( 1 + \frac{u^2(K)}{s_x^2 / N} \right)^2 \quad (4)$$

$v_{\text{eff}}$  as calculated by the equation generally is not an integer so  $v_{\text{eff}}$  should be truncated (rounded down) to an integer. Then, given the significance level, 0.05, the critical value for “ $|T|$ ” is defined to be  $t_{1-\alpha/2}(v_{\text{eff}})$ , the  $(1 - \alpha/2)$ -quantile of the  $t$ -distribution with  $v_{\text{eff}}$  degrees of freedom (see MARLAP Appendix G, Table G.2).

#### 6.4 Analyte Concentration Range

The combined rapid  $^{239/240}\text{Pu}$  - Brick method was evaluated for the required method uncertainty at three test level activities. The five replicate PT samples from each test level concentration were analyzed. The proposed (target) and “as tested” (known) test level activities are presented in Table 1. Note that the final test concentration values for the PT samples varied from the proposed test levels but that these values were well within the sample preparation specifications provided to the PT sample provider.

#### 6.5 Method Specificity

The brick sample is fused using rapid sodium hydroxide fusion at 600 °C in a furnace using zirconium crucibles. It digests refractory particles and eliminates significant interferences from silica and other brick matrix components. Preconcentration of Pu from the alkaline matrix is accomplished using an iron/titanium hydroxide precipitation followed by a lanthanum fluoride precipitation step to remove brick matrix interferences and remove silicates. Pu-238 and Pu-239/240 isotopes are separated and purified using a rapid column method that utilizes TEVA<sup>®</sup>

Resin. After purification,  $^{239/240}\text{Pu}$  is measured using alpha spectrometry at 5.16 MeV. The column separation provides effective removal of interferences and high chemical yields.

## 6.6 Method Ruggedness

The sodium hydroxide fusion has been used successfully on U.S. Department of Energy's Mixed Analyte Performance Evaluation Program soil samples containing refractory actinides. The method is rapid and simple yet very rugged. The lanthanum fluoride step with HF present removes silicates, which tend to clog the resin cartridges and inhibit column flow. The lanthanum fluoride step also removes the large amount of Fe present in brick and used in the preconcentration step so that a small column load solution can be achieved, reducing column separation time. TEVA<sup>®</sup> Resin has very high retention for plutonium (IV), providing high chemical yields and effective removal of interferences.

The method validation external PT samples contained other alpha emitting radionuclides ( $^{241}\text{Am}$ , U and  $^{226}\text{Ra}$ ). The alpha spectra were absent of other alpha emitting radionuclides present in the external PT samples.

## 7. Techniques Used to Evaluate the Measurement Quality Objectives for the Rapid Methods Development Project

A general description of the specifications and techniques used to evaluate the required method uncertainty, required MDC and bias was presented in Section 6. The detailed method evaluation process for each MQO, the bias and the radiochemical yield is presented in this section.

### 7.1 Required Method Uncertainty

The combined rapid  $^{239/240}\text{Pu}$  - Brick method was evaluated following the guidance presented for "Level C Method Validation: Adapted, Newly Developed Methods, Including Rapid Methods" in *Method Validation Guide for Qualifying Methods Used by Radiological Laboratories Participating in Incident Response Activities* (EPA 2009) and Chapter 6 of *Multi-Agency Radiological Laboratory Analytical Protocols Manual* (EPA 2004).

MARLAP "Level C" method validation requires the laboratory to conduct a method validation study wherein five replicate samples from each of the three concentration levels are analyzed according to the method. The concentration test levels analyzed are listed in Table 1. For validation "Level C," externally prepared PT samples consisting of NIST-traceable  $^{239}\text{Pu}$  were used to spike method validation reference material (MVRM). In order to determine if the proposed method met the rapid methods development project MQO requirements for the required method uncertainty ( $u_{\text{MR}} = 0.25 \text{ pCi/g}$ ), each external PT sample result was compared with the method uncertainty acceptance criteria listed in the table below. The acceptance criteria stated in Table 3 for "Level C" validation stipulate that, for each test sample analyzed, the measured value had to be within  $\pm 2.9 u_{\text{MR}}$  (required method uncertainty) for test level activities at or less than the AAL, or  $\pm 2.9 \phi_{\text{MR}}$  (required relative method uncertainty) for test level activities above the AAL.



**Table 3 – MARLAP Level C Acceptance Criteria**

MARLAP Validation Level	Application	Sample Type <sup>[1]</sup>	Acceptance Criteria <sup>[2]</sup>	Number of Test Levels	Number of Replicates	Total Number of Analyses
C	Similar Matrix/New Application	Internal/External 1 PT	Measured value within $\pm 2.9 u_{MR}$ or $\pm 2.9 \phi_{MR}$ of validation value	3	5	15

[1] For this method validation, external PT samples from a NIST-traceable source supplier were used for Phases II and III of the project.

[2] The measured value must be within  $\pm 2.9 u_{MR}$  for test level concentrations at or less than the AAL and within  $\pm 2.9 \phi_{MR}$  for a test level concentration above the AAL. It was assumed that the uncertainty of a test sample concentration will be negligible compared to the method uncertainty acceptance criteria and was not incorporated in the acceptance criteria.

## 7.2 Required Minimum Detectable Concentration

The analytical results reported for the PT samples having a  $^{239/240}\text{Pu}$  concentration at the tested MDC of 0.2040 pCi/g were evaluated according to Sections 5.5.1 and 5.5.2 of Testing for the Required MDC in *Method Validation Guide for Qualifying Methods Used by Radiological Laboratories Participating in Incident Response Activities* (EPA 2009). NAREL analyzed the external PT samples in accordance with the proposed rapid method.

### *Critical Net Concentration*

In order to evaluate whether the combined method can meet the required MDC (0.2040 pCi/g), the critical net concentration, as determined from the results of analytical blanks, must be calculated. The critical net concentration ( $CL_{NC}$ ) with a Type I error probability of  $\alpha = 0.05$ , was calculated using the following equation (consistent with MARLAP, Chapter 20, Equation 20.35):

$$CL_{NC}(\text{pCi}) = t_{1-\alpha}(n-1) \times s_{Blanks} \quad (5)$$

where  $s_{Blanks}$  is the standard deviation of the  $n$  blank-sample net results (corrected for instrument background) in radionuclide concentration units of pCi/g, and  $t_{1-\alpha}(n-1)$  is the  $(1 - \alpha)$ -quantile of the  $t$ -distribution with  $n-1$  degrees of freedom (see MARLAP Table G.2 in Appendix G). For this method validation study a Type I error rate of 0.05 was chosen.

For seven (minimum) blank results (six degrees of freedom) and a Type I error probability of 0.05, the previous equation reduces to:

$$CL_{NC}(\text{pCi}) = 1.94 \times s_{Blanks} \quad (6)$$

The use of the above equations assumes that the method being evaluated has no bias.

### *Verification of Required MDC*

Each of the ten analytical results reported for the PT samples having a concentration at the required MDC for  $^{239/240}\text{Pu}$  (0.2040 pCi/g) was compared to the estimated critical net concentration for the method. The following protocol was used to verify a method's capability to meet the required method MDC for a radionuclide-matrix combination:

- I. Analyze a minimum of seven matrix blank samples for the radionuclide.
- II. From the blank sample net results, calculate the estimated *Critical Net Concentration*,  $CL_{NC}$ .
- III. Analyze ten replicate samples spiked at the required MDC.
- IV. From the results of the ten replicate samples spiked at the required MDC, determine the number (Y) of sample results at or below the estimated  $CL_{NC}$ .
- V. If  $Y \leq 2$ , the method evaluated at the required MDC passes the test for the required MDC specification.
- VI. If  $Y > 2$ , the method evaluated at the required MDC fails the test for the required MDC specification.

## **8. Evaluation of Experimental Results**

Only the experimental results for Phases II and III of the method validation process are reported and evaluated in this study. Information presented in this section will include results for Sections 6 and 7. The  $^{239}\text{Pu}$  analytical results were evaluated for the required method uncertainty, required MDC and bias. In addition, the mean radiochemical yield for the method for Phases II and III is reported to provide the method user the expected mean and range of this method performance characteristic.

### **8.1 Summary of the Combined Rapid $^{239/240}\text{Pu}$ - Brick Method**

The brick sample is fused with sodium hydroxide in zirconium crucibles for ~15 minutes at 600 °C in a furnace. The fused material is dissolved using water and transferred to a centrifuge tube. A preconcentration step with iron/titanium hydroxide enhanced with calcium phosphate is used to remove the Pu from the alkaline matrix. The precipitate is dissolved in dilute acid and a lanthanum fluoride precipitation is performed to further remove brick matrix components such as iron and silicates. The precipitate is redissolved in nitric acid with boric acid and aluminum present and loaded to a TEVA<sup>®</sup> Resin cartridge. U and Am are not retained on TEVA<sup>®</sup> Resin in 3M HNO<sub>3</sub> and Th is removed using a 9M HCl rinse. Pu is eluted from TEVA<sup>®</sup> Resin with a dilute hydrochloric acid-hydrofluoric acid –titanium chloride mixture and alpha spectrometry mounts are prepared using cerium fluoride microprecipitation. Rapid flow rates using vacuum box technology is used to minimize sample preparation time.

## 8.2 Required Method Uncertainty

Table 4A summarizes the  $^{239/240}\text{Pu}$  results and the acceptability of each result compared to the acceptance criteria presented in Section 7.1. The final sample test sources were micro-precipitated on 25 millimeter (mm) filters as  $\text{CeF}_3$  and counted on an alpha spectrometry system for 500 minutes using alpha detectors with a counting sufficiency of ~16%. The count times used were longer than the times in concrete validation (EPA 2014) because the alpha detectors in this laboratory had an efficiency of only 16%, compared to ~25% efficiency detectors used in the laboratory validation of this method for concrete samples. This counting protocol was capable of meeting a required method uncertainty of 0.25 pCi/g at and below the AAL of 1.890 pCi/g. Approximately one gram from the original sample was analyzed.

**Table 4A – Pu-239/240 Analytical Results for Required Method Uncertainty Evaluation**

Nuclide: Pu-239/240

Matrix: Brick

AAL Tested: 1.890 pCi/g

Proposed Method: Combined Rapid

$^{239/240}\text{Pu}$  - Brick Method

Required Method Validation Level:

MARLAP “C”

Required Method Uncertainty,  $u_{\text{MR}}$ :

0.25 pCi/g at and below AAL; 13% above AAL

Acceptance Criteria:

Test Levels 1 and 2:  $2.9 \times u_{\text{MR}} = \pm 0.725$  pCi/g of quoted known value of sample in test level

Test Level 3:  $2.9 \times \phi_{\text{MR}} = \pm 37.7\%$  of quoted known value of sample in test level (5.770 pCi/g)

Test Level 1 Known Value = 0.9280 pCi/g					
Sample	Uncertainty <sup>[1]</sup> (pCi/g)	pCi/g Measured	CSU <sup>[2]</sup> (pCi/g)	Allowable Range (pCi/g)	Acceptable Y/N
P01	0.0093	0.883	0.084	0.22 – 1.6	Y
P02		0.958	0.087		Y
P03		1.004	0.088		Y
P04		0.929	0.088		Y
P05		0.952	0.088		Y
Test Level 2 Known Value = 1.890 pCi/g					
Sample	Uncertainty <sup>[1]</sup> (pCi/g)	pCi/g Measured	CSU <sup>[2]</sup> (pCi/g)	Allowable Range (pCi/g)	Acceptable Y/N
P06	0.019	1.94	0.13	1.2 – 2.6	Y
P07		1.83	0.14		Y
P08		1.73	0.12		Y
P09		1.88	0.13		Y
P10		2.05	0.14		Y

Test Level 3 Known Value = 5.770 pCi/g					
Sample	Uncertainty <sup>[1]</sup> (pCi/g)	pCi/g Measured	CSU <sup>[2]</sup> (pCi/g)	Allowable Range (pCi/g)	Acceptable Y/N
P11	0.058	5.22	0.26	3.6 – 7.9	Y
P12		5.53	0.27		Y
P13		5.67	0.28		Y
P14		5.69	0.28		Y
P15		5.74	0.28		Y

[1] Quoted uncertainty (coverage factor  $k = 1$ ) by the radioactive source manufacturer.

[2] Coverage factor  $k=1$ .

As a measure of the expected variability of results for a test level, the calculated standard deviation of the five measurements of each test level is provided in Table 4B. The standard deviation of the analytical results for a test level was much smaller than the required method uncertainty.

**Table 4B – Experimental Standard Deviation of the Five PT Samples by Test Level.**

Test Level	Mean Concentration Measured (pCi/g)	Standard Deviation of Measurements (pCi/g)	Required Method Uncertainty (pCi/g)
1	0.945	0.044	0.25
2 (AAL)	1.89	0.12	0.25
3	5.57	0.21 (3.8 %)	0.75 <sup>[1]</sup> (13% )

[1] This figure represents the absolute value of the required method uncertainty, calculated by multiplying the known value of Test Level 3 (5.770 pCi/g) by the required relative method uncertainty.

### 8.3 Required Minimum Detectable Concentration

The combined rapid  $^{239/240}\text{Pu}$  - Brick method was validated for the required MDC using  $^{242}\text{Pu}$  as a tracer, a sample aliquant of approximately 1 gram, and an alpha spectrometry counting time of 360 minutes.

Tables 5 and 6 summarize the  $^{239/240}\text{Pu}$  results and the acceptability of the method's performance specified in Section 7.2 to meet the tested required MDC of 0.204 pCi/g.

**Table 5 – Reported  $^{239/240}\text{Pu}$  Concentration Blank Brick Samples**

Sample ID	Concentration (pCi/g)	CSU <sup>[1]</sup> (pCi/g)
P41	-0.0031	0.0088
P42	-0.0022	0.0094
P43	0.009	0.012
P44	-0.0021	0.0090
P45	0.0000	0.0087
P46	-0.0020	0.0086
P47	-0.0011	0.0091

Sample ID	Concentration (pCi/g)	CSU <sup>[1]</sup> (pCi/g)
Mean <sup>[2]</sup>	-0.0003	
Standard Deviation	0.0041	
Critical Net Concentration (pCi/g)	0.0079	
[1] Combined standard uncertainty, coverage factor $k=1$ .		
[2] Mean and standard deviation were calculated before rounding.		

### *Critical Net Concentration*

The critical net concentration for the method under evaluation was calculated using Equation 6 from Section 7.2. Based on the results of the seven blanks (Table 5), the critical net concentration for the combined method was determined to be 0.0079 pCi/g.

### *Required MDC*

A summary of the reported results for samples containing  $^{239/240}\text{Pu}$  at the required MDC is presented in Table 6. The mean measured value and standard deviation of the ten  $^{239/240}\text{Pu}$  in the MDC test samples were calculated as  $0.198 \pm 0.033$  pCi/g ( $k=1$ ). Each result was compared to the critical net concentration of 0.0079 pCi/g. If the result was at or below the critical net concentration, a “Y” qualifier was applied to the sample result; otherwise an “N” qualifier was applied. As presented in the table, the number of Y qualifiers is  $\leq 2$ , so the combined rapid  $^{239}\text{Pu}$  - Brick method evaluated passes the test for the required MDC specification (see *Method Validation Guide for Qualifying Methods Used by Radiological Laboratories Participating in Incident Response Activities* [EPA 2009] for a description of the test).

**Table 6 – Reported Results for Samples Containing  $^{239/240}\text{Pu}$  at the As-Tested MDC Value (0.2040 pCi/g)**

Sample ID	Concentration (pCi/g)	CSU <sup>[1]</sup> (pCi/g)	Test Result $\leq CL_{NC}$ <sup>[3]</sup>
P30	0.145	0.038	N
P31	0.246	0.049	N
P32	0.199	0.044	N
P33	0.201	0.044	N
P34	0.202	0.044	N
P35	0.209	0.044	N
P36	0.201	0.045	N
P37	0.246	0.048	N
P38	0.179	0.040	N
P39	0.154	0.037	N
<b>Mean <sup>[2]</sup></b>	<b>0.198</b>		—
<b>Standard Deviation of Results</b>	<b>0.033</b>		
	$CL_{NC}$	<b>0.0079 pCi/g</b>	—
	<b>Acceptable maximum values <math>\leq CL_{NC}</math> (Y)</b>	2	—
	<b>Number of results <math>&gt; CL_{NC}</math></b>	—	10
	<b>Number of results <math>\leq CL_{NC}</math></b>	—	0
		<b>Evaluation</b>	<b>PASS</b>

[1] Coverage factor  $k=1$ .

[2] Mean and standard deviation were calculated before rounding.

[3] Critical net concentration.

Based on the validation study results, it may be concluded that the combined rapid  $^{239/240}\text{Pu}$  - Brick method is capable of meeting a required MDC for  $^{239/240}\text{Pu}$  of 0.2040 pCi/g (the known value of the MDC PT sample).

#### 8.4 Evaluation of the Absolute and Relative Bias

The  $^{239/240}\text{Pu}$  results for the seven blank brick samples (Table 5), 10 MDC samples (Table 6) and the five replicate PT samples on the three test levels (Table 4A) were evaluated for absolute and relative bias according to the equations presented in Section 6.3. The results and interpretation of the evaluation are presented below in Table 7.

Table 7 – Absolute and Relative Bias Evaluation of the Combined Rapid <sup>239</sup>Pu - Brick Method

Type of Bias	Test Level	Known Value ± CSU ( $k=1$ ) (pCi/g) <sup>[1]</sup>	Mean of Measurements ± Standard Deviation <sup>[2]</sup> (pCi/g)	Difference from Known	Number of Measurements /Degrees of Freedom	T	t <sub>df</sub>	Bias Yes/No
Absolute	Blanks	0.0000	-0.0003 ± 0.0041	-0.0003	7/6	0.16	2.45	N
Relative	MDC	0.2040 ± 0.0020	0.198 ± 0.033	-0.006	10/9	0.55	2.26	N
Relative	1	0.9280 ± 0.0093	0.945 ± 0.044	0.017	5/5	0.79	2.57	N
Relative	2 – AAL	1.890 ± 0.019	1.89 ± 0.12	0.00	5/5	0.07	2.57	N
Relative	3	5.770 ± 0.058	5.57 ± 0.21	-0.20	5/7	1.82	2.36	N

[1] The stated CSU includes the uncertainty in the <sup>239/240</sup>Pu reference standard used to prepare the samples and the standard deviation of the spiked test samples.

[2] Standard deviation of the measurements.

The results for the seven blank samples had a mean and standard deviation of  $-0.0003 \pm 0.0041$  pCi/g. A statistical analysis of the data indicated that there was no absolute bias for the blank brick samples.

No relative bias was noted for the measurements performed on the 10 MDC or any of the method uncertainty test levels. The mean concentration of 0.198 pCi/g for the 10 MDC test samples falls within 0.006 pCi/g (or 2.9 %) of the known value of 0.2040 pCi/g.

As determined by the paired-*t* test described in Section 6, no relative bias was indicated for the any of the method uncertainty test levels. The relative percent difference for each test level was:

- Test Level 1: -1.8%.
- Test Level 2: 0.0%.
- Test Level 3: -3.5 %.

## 8.5 Method Ruggedness and Specificity

The results summarized in Table 8 represent the radiochemical yields for all three test levels, blanks, LCSs and MDC samples that were processed in accordance with the final method in Attachment III.

**Table 8 – Summary of  $^{242}\text{Pu}$  Radiochemical % Yield Results for Test and Quality Control Samples**

<b>Number of Samples</b>	42
<b>Mean Radiochemical Yield</b>	90.0%
<b>Standard Deviation of Distribution (<math>1\sigma</math>)</b>	5.6%
<b>Median</b>	90.7%
<b>Minimum Value</b>	74.8%
<b>5<sup>th</sup> Percentile</b>	81.5%
<b>95<sup>th</sup> Percentile</b>	96.2%
<b>Maximum Value</b>	105.2%

The yields for samples evaluated using this method are shown on Figure 1. The mean yield was high as expected and the standard deviation of the results was tight (~6%). A few samples (blank samples and LCSs) had acceptable yields that were slightly below 80%. These samples do not contain the brick matrix (empty crucibles); therefore, they have slightly lower chemical yields in the preconcentration steps following the rapid sodium hydroxide fusion step, while the Ca and Fe content in the brick matrix enhance the tracer yields slightly.

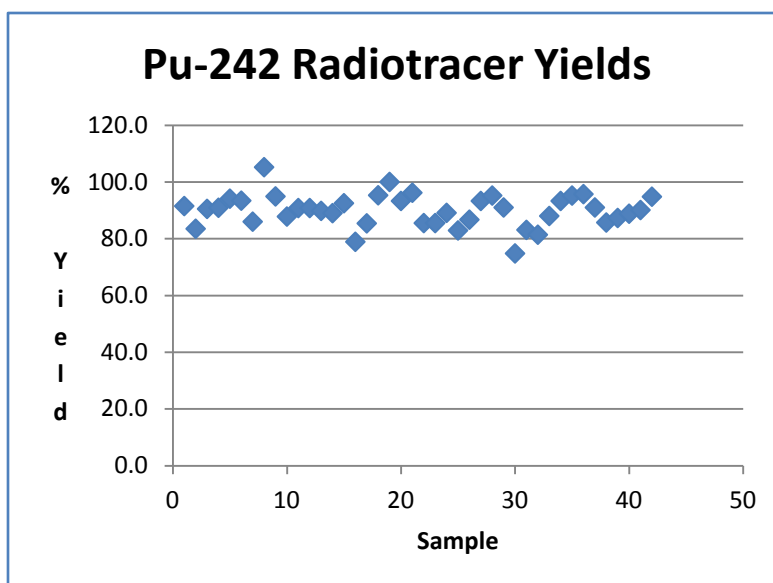
**Figure 1 – Yields for Method Based on Measurement of  $^{242}\text{Pu}$** 

## 9. Timeline to Complete a Batch of Samples

NAREL kept a timeline log on processing a batch of samples and associated internal quality control samples. The total time to process a batch of samples, including counting of the samples and data review/analysis, was approximately 14.25 hours, including a 8.3-hour count time for samples. NAREL's breakdown of the time line by method-process step is presented in Attachment I (this information is also presented in more detail in the method flow chart in Attachment III, Section 17.5).



## 10. Reported Modifications and Recommendations

NAREL performed the method validation and made no significant modifications to the method prior to analyzing samples for Phases II and III of the project.

## 11. Summary and Conclusions

The combined rapid  $^{239/240}\text{Pu}$  - Brick method was successfully validated according to “*Method Validation Requirements for Qualifying Methods Used by Radioanalytical Laboratories Participating in Incident Response Activities*” and Chapter 6 of *Multi-Agency Radiological Laboratory Analytical Protocols Manual* (EPA 2004) for a typical brick matrix containing  $^{241}\text{Am}$ , isotopic uranium,  $^{226}\text{Ra}$ , and  $^{90}\text{Sr}$  in similar concentrations corresponding to a  $10^{-5}$  risk for a soil exposure pathway. The method was evaluated using well-characterized brick analyzed for its macro-constituents by an independent laboratory<sup>3</sup> and for its radiological constituents (Attachment IV) using the combined rapid  $^{239/240}\text{Pu}$  - brick method by NAREL.

The pulverized brick samples were spiked with three low-level  $^{239/240}\text{Pu}$  concentrations (0.9280, 1.890, and 5.770 pCi/g), consistent with a concentration range that incorporated the  $10^{-5}$  exposure risk contaminant level in soil, in the presence of low-level concentrations of  $^{241}\text{Am}$ ,  $^{226}\text{Ra}$ ,  $^{90}\text{Sr}$ , and uranium (Table 1). The combined rapid  $^{239/240}\text{Pu}$  – Brick method met MARLAP Validation Level “C” requirements for required method uncertainty (0.25 pCi/g) at and below the AAL, and for a required relative method uncertainty of (13%) above the AAL concentration of 1.890 pCi/g.

Based on the results of the seven blank brick samples (Table 5), the critical net concentration for the combined method was determined to be 0.0079 pCi/g. The results for the seven blank samples had a mean and standard deviation of  $-0.0003 \pm 0.0041$  pCi/g. A statistical analysis of the data indicated no absolute bias (difference from zero concentration) for the blank brick samples.

The mean measured value and standard deviation of the  $10^{239/240}\text{Pu}$  concentrations in the MDC test samples were calculated as  $0.198 \pm 0.033$  pCi/g ( $k=1$ ). Each result was compared to the critical net concentration of 0.0079 pCi/g. All 10 measurements had a result higher than the critical net concentration, thus verifying the method is capable of meeting a required MDC of 0.2040 pCi/g.

Predicated on the statistical tests provided in the “*Method Validation Requirements for Qualifying Methods Used by Radioanalytical Laboratories Participating in Incident Response Activities*,” the combined method was found not to have a relative bias for the three test levels. The mean relative difference from the known for the low (1/2 AAL) and high (3 AAL) test levels was -1.8%, 0.0% and -3.5%, respectively.

Although radionuclide and chemical interferences ( $^{241}\text{Am}$ , uranium,  $^{90}\text{Sr}$ ,  $^{226}\text{Ra}$ , and typical constituents in the blank brick) were in the test samples, inspection of alpha spectral quality for

---

<sup>3</sup> Wyoming Analytical Laboratories, Inc. of Golden, Colorado, performed the macro analysis.

three sets of test samples support a conclusion that method specificity is adequate under conditions as tested. Additionally, high and reproducible chemical yield results (mean yield =  $90.0 \pm 5.6$  %) was observed for the 42 analyses evaluated. The consistently high tracer yields indicate that the rapid method to determine  $^{239/240}$  Pu in brick samples is robust under the conditions tested. The method is rapid and the validation study indicates it can be used with confidence after a radiological incident for the analysis of emergency brick samples.

## 12. References

- Multi-Agency Radiological Laboratory Analytical Protocols Manual (MARLAP)*. 2004. EPA 402-B-1304 04-001A, July. Volume I, Chapters 6, 7, 20, Glossary; Volume II and Volume III, Appendix G. Available at [www.epa.gov/radiation/marlap/](http://www.epa.gov/radiation/marlap/).
- U.S. Environmental Protection Agency (EPA). 2006. *Validation and Peer Review of U.S. Environmental Protection Agency Radiochemical Methods of Analysis*. FEM Document Number 2006-01, September 29. Available at: [www.epa.gov/fem/agency\\_methods.htm](http://www.epa.gov/fem/agency_methods.htm).
- U.S. Environmental Protection Agency (EPA). 2008. *Radiological Laboratory Sample Analysis Guide for Incidents of National Significance – Radionuclides in Water*, Office of Air and Radiation, Washington, DC, EPA 402-R-07-007, January 2008. Available at: <http://nepis.epa.gov/Adobe/PDF/60000LAW.PDF>.
- U.S. Environmental Protection Agency (EPA). 2009. *Method Validation Guide for Qualifying Methods Used by Radiological Laboratories Participating in Incident Response Activities*. Revision 0. Office of Air and Radiation, Washington, DC. EPA 402-R-09-006, June. Available at: [www.epa.gov/narel/incident\\_guides.html](http://www.epa.gov/narel/incident_guides.html).
- U.S. Environmental Protection Agency (EPA). 2011. *Quality Assurance Project Plan Validation of Rapid Radiochemical Methods For Radionuclides Listed in EPA's Standardized Analytical Methods (SAM) For Use During Homeland Security Events*. July, Revision 2. Office of Air and Radiation, National Air and Radiation Environmental Laboratory.
- U.S. Environmental Protection Agency (EPA). 2012. *Radiological Sample Analysis Guide for Incident Response — Radionuclides in Soil*. Revision 0. Office of Air and Radiation, Washington, DC. EPA 402-R-12-006, September 2012.
- U.S. Environmental Protection Agency (EPA). 2014. *Rapid Radiochemical Method for Plutonium-238 and Plutonium-239/240 in Building Materials for Environmental Remediation Following Radiological Incidents*, Office of Air and Radiation, Washington, DC, EPA 402-R-07-007, April 2014. Unpublished.

**Attachment I:  
Estimated Elapsed Times  
Combined Rapid 239/240Pu - Brick Method**

Step	Elapsed Time (hours)*
Rapid Fusion	3
Vacuum Box Setup	3.25
Load Sample to TEVA <sup>®</sup> cartridges	4.75
Pu separation on TEVA <sup>®</sup> Resin	5.25
Microprecipitation	6.25
Count sample test source (1–8 hours)	7.25-14.25

\* These estimates depend on the number of samples that can be processed simultaneously. These estimates are based on ~15-20 samples. Eight-hour count times were used because the alpha detectors used had ~16% counting efficiencies. Shorter count times can likely be used for alpha detectors with higher efficiencies as long as uncertainty requirements are met.

## Attachment II:

### **Rapid Method for Sodium Hydroxide Fusion of Concrete<sup>4</sup> and Brick Matrices Prior to Americium, Plutonium, Strontium, Radium, and Uranium Analyses for Environmental Remediation Following Radiological Incidents**

#### 1. Scope and Application

- 1.1. The method is applicable to the sodium hydroxide fusion of concrete and brick samples, prior to the chemical separation procedures described in the following procedures:
  - 1.1.1. Rapid Radiochemical Method for Americium-241 in Building Materials for Environmental Remediation Following Radiological Incidents (Reference 16.1).
  - 1.1.2. Rapid Radiochemical Method for Plutonium-238 and Plutonium-239/240 in Building Materials for Environmental Remediation Following Radiological Incidents (Reference 16.2).
  - 1.1.3. Rapid Radiochemical Method for Radium-226 in Building Materials for Environmental Remediation Following Radiological Incidents (Reference 16.3).
  - 1.1.4. Rapid Radiochemical Method for Total Radiostrontium (Sr-90) in Building Materials for Environmental Remediation Following Radiological Incidents (Reference 16.4).
  - 1.1.5. Rapid Radiochemical Method for Isotopic Uranium in Building Materials for Environmental Remediation Following Radiological Incidents (Reference 16.5).
- 1.2. This general method for concrete and brick building material applies to samples collected following a radiological or nuclear incident. The concrete and brick samples may be received as core samples, pieces of various sizes, dust or particles (wet or dry) from scabbling, or powder samples.
- 1.3. The fusion method is rapid and rigorous, effectively digesting refractory radionuclide particles that may be present.
- 1.4. Concrete or brick samples should be ground to at least 50–100 mesh size prior to fusion, if possible.
- 1.5. After a homogeneous, finely ground sample is obtained, the dissolution of concrete or brick matrices by this fusion method is expected to take approximately 1 hour per batch of 20 samples. This method assumes the laboratory starts with a representative, finely ground, 1–1.5-g aliquant of sample and employs simultaneous heating in multiple furnaces. The preconcentration steps to eliminate the alkaline fusion matrix and collect the radionuclides are expected to take approximately 1 hour.

---

<sup>4</sup> U.S. Environmental Protection Agency (EPA). 2014. *Rapid Radiochemical Method for Plutonium-238 and Plutonium-239/240 in Building Materials for Environmental Remediation Following Radiological Incidents*, Office of Air and Radiation, Washington, DC, EPA 402-R-07-007, April 2014. Unpublished.

- 1.6. As this method is a sample digestion and pretreatment technique, to be used prior to other separation and analysis methods, the user should refer to those individual methods and any project-specific requirements for the determination of applicable measurement quality objectives (MQOs).
- 1.7. Application of this method by any laboratory should be validated by the laboratory using the protocols provided in *Method Validation Guide for Qualifying Methods Used by Radioanalytical Laboratories Participating in Incident Response Activities* (Reference 16.6), or the protocols published by a recognized standards organization for method validation.
  - 1.7.1. In the absence of project-specific guidance, MQOs for concrete or brick samples may be based on the Analytical Action Levels (AALs), the Required Method Uncertainty ( $u_{MR}$ ) and the Required Relative Method Uncertainty ( $\phi_{MR}$ ) found in the *Radiological Laboratory Sample Analysis Guide for Incident Response — Radionuclides in Soil* (Reference 16.7).

## 2. Summary of Method

- 2.1. The method is based on the rapid fusion of a representative, finely ground 1–1.5-g aliquant using rapid sodium hydroxide fusion at 600 °C.
- 2.2. Pu, U, and Am are separated from the alkaline matrix using an iron/titanium hydroxide precipitation (enhanced with calcium phosphate precipitation) followed by a lanthanum fluoride matrix removal step.
- 2.3. Sr is separated from the alkaline matrix using a carbonate precipitation, followed by a calcium fluoride precipitation to remove silicates.
- 2.4. Ra is separated from the alkaline matrix using a carbonate precipitation.

## 3. Definitions, Abbreviations and Acronyms

- 3.1. Discrete Radioactive Particles (DRPs or “hot particles”). Particulate matter in a sample of any matrix where a high concentration of radioactive material is present as a tiny particle ( $\mu\text{m}$  range).
- 3.2. *Multi-Agency Radiological Analytical Laboratory Protocols (MARLAP) Manual* (Reference 16.8).
- 3.3. The use of the term concrete or brick throughout this method is not intended to be limiting or prescriptive, and the method described herein refers to all concrete or masonry-related materials. In cases where the distinction is important, the specific issues related to a particular sample type will be discussed.

## 4. Interferences and Limitations

**NOTE: Large amounts of extraneous debris (pebbles larger than ¼", non-soil related debris) are not generally considered to be part of a concrete or brick matrix. When consistent with data quality objectives (DQOs), materials should be removed from the sample prior to drying. It is recommended this step be verified with Incident Command before discarding any materials.**

- 4.1. Concrete or brick samples with larger particle size may require a longer fusion time during Step 11.1.8.
- 4.2. As much information regarding the elemental composition of the sample should be obtained as possible. For example some concrete or brick may have native concentrations of uranium, radium, thorium, strontium or barium, all of which may have an effect on the chemical separations used following the fusion of the sample. In some cases (e.g., radium or strontium analysis), elemental analysis of the digest prior to chemical separations may be necessary to determine native concentrations of carrier elements present in the sample.

**NOTE: In those samples where native constituents are present that could interfere with the determination of the chemical yield (e.g., strontium for  $^{90}\text{Sr}$  analysis) or with the creation of a sample test source (e.g., Ba for  $^{226}\text{Ra}$  analysis by alpha spectrometry), it may be necessary to determine the concentration of these native constituents in advance of chemical separation (using a separate aliquant of fused material) and make appropriate adjustments to the yield calculations or amount of carrier added.**

- 4.3. Matrix blanks for these matrices may not be practical to obtain. Efforts should be made to obtain independent, analyte-free materials that have similar composition as the samples to be analyzed. These blanks will serve as process monitors for the fusion, and as potential monitors for cross contamination during batch processing.
- 4.4. Uncontaminated concrete or brick material may be acceptable blank material for Pu, Am, and Sr analyses, but these materials will typically contain background levels of U and Ra isotopes.
  - 4.4.1. If analyte-free blank material is not available and an empty crucible is used to generate a reagent blank sample, it is recommended that 100–125 milligram (mg) calcium (Ca) per gram of samples be added as calcium nitrate to the empty crucible as blank simulant. This step facilitates Sr/Ra carbonate precipitations from the alkaline fusion matrix.
  - 4.4.2. Tracer yields may be slightly lower for reagent blank matrices, since the concrete and brick matrix components typically enhance recoveries across the precipitation steps.
- 4.5. Samples with elevated activity or samples that require multiple analyses from a single concrete or brick sample may need to be split after dissolution. In these cases the initial digestate and the split fractions should be carefully measured to ensure that the sample aliquant for analysis is accurately determined.
  - 4.5.1. Tracer or carrier amounts (added for yield determination) may be increased where the split allows for the normal added amount to be present in the subsequent aliquant. For very high activity samples, the addition of the tracer or carrier may need to be postponed until following the split, in which case special care must be taken to ensure that the process is quantitative until isotopic exchange with the yield monitor is achieved. This deviation from the method should be thoroughly documented and reported in the case narrative.

- 4.5.2. When this method is employed and the entire volume of fused sample is processed in the subsequent chemical separation method, the original sample size and units are used in all calculations, with the final results reported in the units requested by the project manager.
- 4.5.3. In cases where the sample digestate is split prior to analysis, the fractional aliquant of the sample is used to determine the sample size. The calculation of the appropriate sample size used for analysis is described in Section 12, below.
- 4.6. In the preparation of blank samples, laboratory control samples (LCSs) and duplicates, care should be taken to create these quality control samples as early in the process as possible, and to follow the same tracer/carrier additions, digestion process, and sample splitting used for the field samples. In the case of this method, quality control samples should be initiated at the point samples are aliquanted into crucibles for the fusion.
- 4.7. Although this method is applicable to a variety of subsequent chemical separation procedures, it is not appropriate where the analysis of volatile constituents such as iodine or polonium is required. The user of this method must ensure that analysis is not required for any radionuclide that may be volatile under these sample preparation conditions, prior to performing this procedure.
- 4.8. Zirconium crucibles used in the fusion process may be reused.
  - 4.8.1. It is very important that the laboratory have a process for cleaning and residual contamination assessment of the reused zirconium crucibles. The crucibles should be cleaned very well using soap and water, followed by warm nitric acid and then water. Blank measurements should be monitored to ensure effective cleaning.
  - 4.8.2. Segregation of crucibles used for low and high activity samples is recommended to minimize the risk of cross-contamination while maximizing the efficient use of crucibles.
- 4.9. Centrifuge speed of 3500 rpm is prescribed but lower rpm speeds (>2500 rpm) may be used if 3500 rpm is not available.
- 4.10. Titanium chloride ( $\text{TiCl}_3$ ) reductant is used during the co-precipitation step with iron hydroxide for actinides to ensure tracer equilibrium and reduce uranium from  $\text{U}^{+6}$  to  $\text{U}^{+4}$  to enhance chemical yields. This method adds 5 mL 10 percent by mass (wt%)  $\text{TiCl}_3$  along with the Fe. Adding up to 10 mL of 10 wt%  $\text{TiCl}_3$  may increase uranium chemical yields, but this will need to be validated by the laboratory.
- 4.11. Trace levels of  $^{226}\text{Ra}$  may be present in  $\text{Na}_2\text{CO}_3$  used in the  $^{226}\text{Ra}$  pre-concentration step used in this method. Adding less 2M  $\text{Na}_2\text{CO}_3$  (<25 mL used in this method) may reduce  $^{226}\text{Ra}$  reagent blank levels, while still effectively pre-concentrating  $^{226}\text{Ra}$  from the fusion matrix. This will need to be validated by the laboratory.
- 4.12. La is used to pre-concentrate actinides along with  $\text{LaF}_3$  in this method to eliminate matrix interferences, including silica, which can cause column flow problems. La follows Am in subsequent column separations and must be removed. Less La (2 mg) was used for brick samples to minimize the chance of La interference on alpha

spectrometry peaks. While this may also be effective for concrete samples, this will have to be validated by the laboratory.

## 5. Safety

### 5.1. General

- 5.1.1. Refer to your laboratory safety manual for concerns of contamination control, personal exposure monitoring and radiation dose monitoring.
- 5.1.2. Refer to your laboratory's chemical hygiene plan (or equivalent) for general safety rules regarding chemicals in the workplace.

### 5.2. Radiological

- 5.2.1. Discrete Radioactive Particles (DRPs or "hot particles")
  - 5.2.1.1. Hot particles will be small, on the order of 1 millimeter (mm) or less. DRPs are typically not evenly distributed in the media and their radiation emissions are not uniform in all directions (anisotropic).
  - 5.2.1.2. Concrete/brick media should be individually surveyed using a thickness of the solid sample that is appropriate for detection of the radionuclide decay particles.

**NOTE: The information regarding DRPs should accompany the samples during processing as well as be described in the case narrative that accompanies the sample results.**

### 5.3. Procedure-Specific Non-Radiological Hazards:

- 5.3.1. The sodium hydroxide fusion is performed in a furnace at 600 °C. The operator should exercise extreme care when using the furnace and when handling the hot crucibles. Long tongs are recommended. Thermal protection gloves are also recommended when performing this part of the procedure. The fusion furnace should be used in a ventilated area (hood, trunk exhaust, etc.).
- 5.3.2. Particular attention should be paid to the use of hydrofluoric acid (HF). HF is an extremely dangerous chemical used in the preparation of some of the reagents and in the microprecipitation procedure. Appropriate personal protective equipment (PPE) must be used in strict accordance with the laboratory safety program specification.

## 6. Equipment and Supplies

- 6.1. Adjustable temperature laboratory hotplates.
- 6.2. Balance, top loading or analytical, readout display of at least  $\pm 0.01$  g.
- 6.3. Beakers, 100 mL, 150 mL capacity.
- 6.4. Centrifuge able to accommodate 225 mL tubes.
- 6.5. Centrifuge tubes, plastic, 50 mL and 225 mL capacity.
- 6.6. Crucibles, 250 mL, zirconium, with lids.



- 6.7. 100  $\mu\text{L}$ , 200  $\mu\text{L}$ , 500  $\mu\text{L}$ , and 1 mL pipets or equivalent and appropriate plastic tips.
- 6.8. 1-10 mL electronic/manual pipet(s).
- 6.9. Drill with masonry bit ( $\frac{1}{4}$ -inch carbide bit recommended).
- 6.10. Hot water bath or dry bath equivalent.
- 6.11. Ice bath.
- 6.12. Muffle furnace capable of reaching at least 600 °C.
- 6.13. Tongs for handling crucibles (small and long tongs).
- 6.14. Tweezers or forceps.
- 6.15. Sample size reduction equipment (ball mill, paint shaker, etc.) and screens. The necessary equipment will be based on a laboratory's specific method for the process of producing a uniformly ground sample from which to procure an aliquant.  
**NOTE: See appendix for a method for ball-milling and homogenization of concrete or brick.**
- 6.16. Vortex stirrer.

## 7. Reagents and Standards

### NOTES:

**Unless otherwise indicated, all references to water should be understood to mean Type I reagent water (ASTM D1193; Reference 16.9).**

**All reagents are American Chemical Society (ACS)-grade or equivalent unless otherwise specified.**

- 7.1. Type I reagent water as defined in ASTM Standard D1193 (Reference 16.9).
- 7.2. Aluminum nitrate ( $\text{Al}(\text{NO}_3)_3 \cdot 9\text{H}_2\text{O}$ )
  - 7.2.1. Aluminum nitrate solution (2M): Add 750 g of aluminum nitrate ( $\text{Al}(\text{NO}_3)_3 \cdot 9\text{H}_2\text{O}$ ) to ~700 mL of water and dilute to 1 L with water. Low-levels of uranium are typically present in  $\text{Al}(\text{NO}_3)_3$  solution.  
**NOTE: Aluminum nitrate reagent typically contains trace levels of uranium concentration. To achieve the lowest possible blanks for isotopic uranium measurements, some labs have removed the trace uranium by passing ~250 mL of the 2M aluminum nitrate reagent through ~7 mL TRU<sup>®</sup> Resin or UTEVA<sup>®</sup> Resin (Eichrom Technologies), but this will have to be tested and validated by the laboratory.**
- 7.3. Ammonium hydrogen phosphate (3.2M): Dissolve 106 g of  $(\text{NH}_4)_2\text{HPO}_4$  in 200 mL of water, heat on low to medium heat on a hot plate to dissolve and dilute to 250 mL with water.
- 7.4. Boric Acid,  $\text{H}_3\text{BO}_3$ .
- 7.5. Calcium nitrate (1.25M): Dissolve 147 g of calcium nitrate tetrahydrate ( $\text{Ca}(\text{NO}_3)_2 \cdot 4\text{H}_2\text{O}$ ) in 300 mL of water and dilute to 500 mL with water.
- 7.6. Iron carrier (50 mg/mL): Dissolve 181 g of ferric nitrate ( $\text{Fe}(\text{NO}_3)_3 \cdot 9\text{H}_2\text{O}$ ) in 300 mL water and dilute to 500 mL with water.
- 7.7. Hydrochloric acid (12M): Concentrated HCl, available commercially.

- 7.6.1. Hydrochloric acid (0.01M): Add 0.83 mL of concentrated HCl to 800 mL of water and dilute with water to 1 L.
- 7.6.2. Hydrochloric acid (1.5M): Add 125 mL of concentrated HCl to 800 mL of water and dilute with water to 1 L.
- 7.8. Hydrofluoric acid (28M): Concentrated HF, available commercially.
- 7.9. Lanthanum carrier (1.0 mg La<sup>3+</sup>/mL): Add 1.56 g lanthanum (III) nitrate hexahydrate [La(NO<sub>3</sub>)<sub>3</sub> · 6H<sub>2</sub>O] in 300 mL water, diluted to 500 mL with water.
- 7.10. Nitric acid (16M): Concentrated HNO<sub>3</sub>, available commercially.
  - 7.10.1. Nitric acid (3M): Add 191 mL of concentrated HNO<sub>3</sub> to 700 mL of water and dilute to 1 L with water.
  - 7.10.2. Nitric acid–boric acid solution (3M-0.25M): Add 15.4 g of boric acid and 190 mL of concentrated HNO<sub>3</sub> to 500 mL of water, heat to dissolve, and dilute to 1 liter with water.
  - 7.10.3. Nitric acid (7M): Add 443 mL of concentrated HNO<sub>3</sub> to 400 mL of water and dilute to 1 L with water.
  - 7.10.4. Nitric acid (8M): Add 506 mL of concentrated HNO<sub>3</sub> to 400 mL of water and dilute to 1 L with water.
- 7.11. Sodium carbonate (2M): Dissolve 212 g anhydrous Na<sub>2</sub>CO<sub>3</sub> in 800 mL of water, then dilute to 1 L with water.
- 7.12. Sodium hydroxide pellets.
- 7.13. Titanium (III) chloride solution (TiCl<sub>3</sub>), 10 wt% solution in 20–30 wt% hydrochloric acid.
- 7.14. Radioactive tracers/carriers (used as yield monitors) and spiking solutions. A radiotracer is a radioactive isotope of the analyte that is added to the sample to measure any losses of the analyte. A carrier is a stable isotope form of a radionuclide (usually the analyte) added to increase the total amount of that element so that a measureable mass of the element is present. A carrier can be used to determine the yield of the chemical process and/or to carry the analyte or radiotracer through the chemical process. Refer to the chemical separation method(s) to be employed upon completion of this dissolution technique. Tracers/carriers that are used to monitor radiochemical/chemical yield should be added at the beginning of this procedure. This timing allows for monitoring and correction of chemical losses in the combined digestion process, as well as in the chemical separation method. Carriers used to prepare sample test sources but not used for chemical yield determination (e.g., cerium added for microprecipitation of plutonium or uranium), should be added where indicated.

## 8. Sample Collection, Preservation, and Storage

Not Applicable.

## 9. Quality Control

- 9.1. Where the subsequent chemical separation technique requires the addition of carriers and radioactive tracers for chemical yield determinations, these are to be added prior to beginning the fusion procedure, unless there is good technical justification for doing otherwise.
- 9.2. Batch quality control results shall be evaluated and meet applicable analytical protocol specifications (APS) prior to release of unqualified data. In the absence of project-defined APS or a project-specific quality assurance project plan (QAPP), the quality control sample acceptance criteria defined in the laboratory's Quality Manual and procedures shall be used to determine acceptable performance for this method.
  - 9.2.1. An exception to this approach may need to be taken for samples of exceptionally high activity where human safety may be involved.
- 9.3. Quality control samples are generally specified in the laboratory's Quality Manual or in a project's APS. At the very minimum the following are suggested:
  - 9.3.1. A laboratory control sample (LCS), which consists solely of the reagents used in this procedure and a known quantity of radionuclide spiking solution, shall be run with each batch of samples. The concentration of the LCS should be at or near the action level or level of interest for the project
  - 9.3.2. One reagent blank shall be run with each batch of samples. The blank should consist solely of the reagents used in this procedure (including tracer or carrier from the analytical method added prior to the fusion process).
  - 9.3.3. A sample duplicate that is equal in size to the original aliquant should be analyzed with each batch of samples. This approach provides assurance that the laboratory's sample size reduction and sub-sampling processes are reproducible.

## 10. Calibration and Standardization

- 10.1. Refer to the individual chemical separation and analysis methods for calibration and standardization protocols.

## 11. Procedure

### 11.1. Fusion

- 11.1.1. In accordance with the DQOs and sample processing requirements stated in the project plan documents, remove extraneous materials from the concrete or brick sample using a clean forceps or tweezers.
- 11.1.2. Weigh out a representative, finely ground 1-g aliquant of sample into a labeled crucible (1.5-g aliquants for  $^{90}\text{Sr}$  analysis).

#### NOTES:

**It is anticipated that concrete or brick powder sample material will be dry enough to aliquant without a preliminary drying step. In the event samples are received that**

contain moisture, the samples may be dried in a drying oven at 105 °C prior to taking the aliquant.

For Sr and Ra analyses, a reagent blank of 100–150 mg calcium per gram of sample (prepared by evaporating 2.5 mL of 1.25M calcium nitrate,  $\text{Ca}(\text{NO}_3)_2$ , for radium and 3 mL of 1.25M  $\text{Ca}(\text{NO}_3)_2$  for strontium) should be added to the crucible as a blank simulant to ensure the blank behaves like the concrete or brick samples during the precipitation steps.

- 11.1.3. Add the proper amount of tracer or carrier appropriate for the method being used and the number of aliquants needed.
- 11.1.4. Place crucibles on a hot plate and heat to dryness on medium heat.  
**NOTE: Heat on medium heat to dry quickly but not so high as to cause splattering.**
- 11.1.5. Remove crucibles from hot plate and allow to cool.
- 11.1.6. Add the following amounts of sodium hydroxide based on the aliquant size/analysis required.

1 g for Pu, Am, U:	15 g NaOH
1.5 g for Sr:	15 g NaOH
1 g for Ra:	10 g NaOH
- 11.1.7. Place the crucibles with lids in the 600 °C furnace using tongs.
- 11.1.8. Fuse samples in the crucibles for ~15 minutes.  
**NOTE: Longer times may be needed for larger particles.**
- 11.1.9. Remove hot crucibles from furnace very carefully using tongs, and transfer to hood.
- 11.1.10. Add ~25-50 mL of water to each crucible ~8 to 10 minutes (or longer) after removing crucibles from furnace, and heat on hotplate to loosen/dissolve solids.
- 11.1.11. If necessary for dissolution, add more water, and warm as needed on a hotplate.
- 11.1.12. Proceed to Section 11.2 for the actinide preconcentration procedure, 11.3 or 11.4 for Sr preconcentration, or 11.5 for Ra preconcentration steps.
- 11.2. Preconcentration of Actinides (Pu, U, or Am) from Hydroxide Matrix
  - 11.2.1. Pipet 2.5 mL of iron carrier (50 mg/mL) into a labeled 225-mL centrifuge tube for each sample.
  - 11.2.2. Add La carrier to each 225-mL tube as follows:

Concrete: 5 mL of 1 mg La/mL for Pu, Am, U
Brick: 5 mL of 1 mg La/mL for Pu, and U; 2 mL 1 mg La/mL for Am
  - 11.2.3. Transfer each fused sample to a labeled 225 mL centrifuge tube, rinse crucibles well with water, and transfer rinses to each tube.
  - 11.2.4. Dilute each sample to approximately 180 mL with water.

- 11.2.5. Cool the 225 mL centrifuge tubes in an ice bath to approximately room temperature as needed.
- 11.2.6. Pipet 1.25M  $\text{Ca}(\text{NO}_3)_2$  and 3.2M  $(\text{NH}_4)_2\text{HPO}_4$  into each tube as follows:  
Pu, Am: 2 mL 1.25M  $\text{Ca}(\text{NO}_3)_2$  and 3 mL 3.2M  $(\text{NH}_4)_2\text{HPO}_4$   
U: 3 mL 1.25M  $\text{Ca}(\text{NO}_3)_2$  and 5 mL 3.2M  $(\text{NH}_4)_2\text{HPO}_4$
- 11.2.7. Cap tubes and mix well.
- 11.2.8. Pipet 5 mL of 10 wt%  $\text{TiCl}_3$  into each tube, and cap and mix immediately.
- 11.2.9. Cool 225 mL centrifuge tubes in an ice bath for ~10 minutes.
- 11.2.10. Centrifuge tubes for 6 minutes at 3500 rpm.
- 11.2.11. Pour off the supernate, and discard to waste.
- 11.2.12. Add 1.5M HCl to each tube to redissolve each sample in a total volume of ~60 mL.
- 11.2.13. Cap and shake each tube to dissolve solids as well as possible.  
**NOTE: There will typically be undissolved solids, which is acceptable.**
- 11.2.14. Dilute each tube to ~170 mL with 0.01M HCl. Cap and mix.
- 11.2.15. Pipet 1 mL of 1.0 mg La/mL into each tube.
- 11.2.16. Pipet 3 mL of 10 wt%  $\text{TiCl}_3$  into each tube. Cap and mix.
- 11.2.17. Add 22 mL of concentrated HF into each tube. Cap and mix well.
- 11.2.18. Place tubes to set in an ice bath for ~10 minutes to get the tubes very cold.
- 11.2.19. Centrifuge for ~10 minutes at 3000 rpm or more, as needed.
- 11.2.20. Pour off supernate, and discard to waste.
- 11.2.21. Pipet 5 mL of 3M  $\text{HNO}_3$  - 0.25M boric acid into each tube.
- 11.2.22. Cap, mix and transfer contents of the tube into a labeled 50 mL centrifuge tube.
- 11.2.23. Pipet 6 mL of 7M  $\text{HNO}_3$  and 7 mL of 2M aluminum nitrate into each tube, cap and mix (shake or use a vortex stirrer), and transfer rinse to 50-mL centrifuge tube.
- 11.2.24. Pipet 3 ml of 3M  $\text{HNO}_3$  directly into the 50 mL centrifuge tube.
- 11.2.25. Warm each 50 mL centrifuge tube in a hot water bath for a few minutes, swirling to dissolve.
- 11.2.26. Remove each 50 mL centrifuge tube from the water bath and allow to cool to room temperature
- 11.2.27. Centrifuge the 50 ml tubes at 3500 rpm for 5 minutes to remove any traces of solids (may not be visible prior to centrifuging), and transfer solutions to labeled beakers or tubes for further processing. Discard any solids.

11.2.28. Proceed directly to any of those methods listed in Sections 1.1.1, 1.1.2, or 1.1.5 (for Pu, U, or Am).

11.3. Preconcentration of  $^{90}\text{Sr}$  from Hydroxide Matrix (Concrete)

**NOTE: The preconcentration steps for  $^{90}\text{Sr}$  in this section can also be applied to brick samples, but this will have to be validated by the laboratory. See Section 11.4 for steps validated for  $^{90}\text{Sr}$  in brick samples.**

- 11.3.1. Transfer each fused sample to a 225-mL centrifuge tube, rinse crucibles well with water, and transfer rinses to each tube.
- 11.3.2. Dilute to approximately 150 mL with water.
- 11.3.3. Add 15-mL concentrated HCl to each tube.
- 11.3.4. Cap and mix solution in each tube.
- 11.3.5. Pipet 1-mL of 1.25M  $\text{Ca}(\text{NO}_3)_2$  into each tube.
- 11.3.6. Add 2-mL of 50-mg/mL iron carrier into each tube.
- 11.3.7. Add 25-mL of 2M  $\text{Na}_2\text{CO}_3$  to each tube.
- 11.3.8. Cap tubes and mix well.
- 11.3.9. Cool the 225-mL centrifuge tubes in an ice bath for ~10 minutes.
- 11.3.10. Centrifuge tubes for 5 minutes at 3500 rpm.
- 11.3.11. Pour off the supernate, and discard to waste.
- 11.3.12. Add 1.5M HCl to each tube to redissolve each sample in a total volume of ~50 mL.
- 11.3.13. Cap and shake each tube to dissolve solids as well as possible.
- 11.3.14. Dilute each tube to ~170 mL with 0.01M HCl. Cap and mix.
- 11.3.15. Add 22 mL of concentrated HF into each tube. Cap and mix well.
- 11.3.16. Place tubes to set in an ice bath for ~10 minutes to get the tubes very cold.
- 11.3.17. Centrifuge for ~6 minutes at 3500 rpm.
- 11.3.18. Pour off supernate, and discard to waste.
- 11.3.19. Pipet 5 mL of concentrated  $\text{HNO}_3$  and 5 mL of 3M  $\text{HNO}_3$  - 0.25M boric acid into each 225 mL tube to dissolve precipitate.
- 11.3.20. Cap and mix well. Transfer contents of the tube into a labeled 50-mL centrifuge tube.
- 11.3.21. Pipet 5 mL of 3M  $\text{HNO}_3$  and 5 mL of 2M aluminum nitrate into each tube, cap tube and mix.
- 11.3.22. Transfer rinse solutions to labeled 50-mL centrifuge tubes and mix well (shake or use vortex stirrer).
- 11.3.23. Centrifuge the 50 mL tubes at 3500 rpm for 5 minutes to remove any traces of solids.

- 11.3.24. Transfer solutions to labeled beakers or new 50 mL tubes for further processing.
  - 11.3.25. If solids remain in the original 50 mL tubes (step 11.3.23), add 5 mL of 3M HNO<sub>3</sub> to each tube containing solids, cap, and mix well, Centrifuge for 5 minutes and add the supernate to the sample solution from step 11.3.24. Discard any remaining solids.
  - 11.3.26. Set aside for <sup>90</sup>Sr analysis using *Rapid Radiochemical Method for Total Radiostrontium (Sr-90) In Building Materials for Environmental Remediation Following Radiological Incidents* (Reference 16.4).
- 11.4. Preconcentration of <sup>90</sup>Sr from Hydroxide Matrix (Brick)
- NOTE: The preconcentration steps for <sup>90</sup>Sr in this section, using calcium phosphate instead of calcium carbonate, can also be applied to concrete samples but this will have to be validated by the laboratory. See Section 11.3 for steps validated for <sup>90</sup>Sr in concrete samples.**
- 11.4.1. Transfer each fused sample to a labeled 225-mL centrifuge tube, rinse crucibles well with water, and transfer rinses to each tube.
  - 11.4.2. Dilute to approximately 150 mL with water.
  - 11.4.3. Pipet 2 mL 1.25M Ca(NO<sub>3</sub>)<sub>2</sub> into each tube.
  - 11.4.4. Add 1 mL 50-mg/mL iron carrier into each tube.
  - 11.4.5. Add 5 mL 3.2M (NH<sub>4</sub>)<sub>2</sub>HPO<sub>4</sub> to each tube.
  - 11.4.6. Cap tubes and mix well.
  - 11.4.7. Centrifuge tubes for 5 minutes at 3500 rpm.
  - 11.4.8. Pour off the supernate and discard to waste.
  - 11.4.9. Add 1.5M HCl to each tube to redissolve each sample in a total volume of ~60 mL.
  - 11.4.10. Cap and shake each tube to dissolve solids as well as possible.
  - 11.4.11. Dilute each tube to ~170 mL with 0.01M HCl. Cap and mix.
  - 11.4.12. Add 22 mL of concentrated HF into each tube. Cap and mix well.
  - 11.4.13. Place tubes to set in an ice bath for ~10 minutes to get the tubes very cold.
  - 11.4.14. Centrifuge for ~6 minutes at 3500 rpm.
  - 11.4.15. Pour off supernate and discard to waste.
  - 11.4.16. Pipet 5 mL of concentrated HNO<sub>3</sub> and 5 mL of 3M HNO<sub>3</sub> – 0.25M boric acid into each 225 mL tube to dissolve precipitate.
  - 11.4.17. Cap and mix well. Transfer contents of the tube into a labeled 50-mL centrifuge tube.
  - 11.4.18. Pipet 5 mL of 3M HNO<sub>3</sub> and 5 mL of 2M aluminum nitrate into each tube, cap tube and mix.

- 11.4.19. Transfer rinse solutions to labeled 50 mL centrifuge tubes and mix well (shake or use vortex stirrer).
- 11.4.20. Centrifuge the 50 mL tubes at 3500 rpm for 5 minutes to remove any traces of solids.
- 11.4.21. Transfer solutions to labeled beakers or new 50 mL tubes for further processing.
- 11.4.22. If solids remain in the original 50 mL tubes (step 11.4.20), add 5 mL of 3M HNO<sub>3</sub> to each tube containing solids, cap, and mix well, Centrifuge for 5 minutes and add the supernate to the sample solution from step 11.4.21. Discard any remaining solids.
- 11.4.23. Set aside for <sup>90</sup>Sr analysis using *Rapid Radiochemical Method for Total Radiostrontium (Sr-90) In Building Materials for Environmental Remediation Following Radiological Incidents* (Reference 16.4).
- 11.5. Preconcentration of <sup>226</sup>Ra from Hydroxide Matrix
  - 11.5.1. Transfer each sample to a labeled 225 mL centrifuge tube, rinse crucibles well with water, and transfer rinses to each tube.
  - 11.5.2. Dilute to approximately 150 mL with water.
  - 11.5.3. Add 10 mL of concentrated HCl to each tube.
  - 11.5.4. Cap and mix each tube well.
  - 11.5.5. Pipet 0.5 mL of 1.25M Ca(NO<sub>3</sub>)<sub>2</sub> into each tube.
  - 11.5.6. Add 25 mL of 2M Na<sub>2</sub>CO<sub>3</sub> to each tube.
  - 11.5.7. Cap tubes and mix.
  - 11.5.8. Cool the 225-mL centrifuge tubes in an ice bath for ~5–10 minutes.
  - 11.5.9. Centrifuge tubes for 6 minutes at 3500 rpm.
  - 11.5.10. Pour off the supernate, and discard to waste.
  - 11.5.11. Pipet 10 mL 1.5M HCl into each tube to dissolve precipitate. Cap and mix.
  - 11.5.12. Transfer sample solution to a labeled 50-mL centrifuge tube.
  - 11.5.13. Pipet 10 mL 1.5M HCl into each 225-mL tube to rinse. Cap and rinse well.
  - 11.5.14. Transfer rinse solution to 50 mL-tube and mix well.

**NOTE: Typically the HCl added to dissolve the carbonate precipitate is sufficient to acidify the sample. If the precipitate was unusually large and milky suspended solids remain, indicating additional acid is needed, the pH can be checked to verify it is pH 1 or less. To acidify the pH <1, 1 or 2 mL of concentrated hydrochloric acid may be added to acidify the solution further and get it to clear. Undissolved solids may be more likely to occur with brick samples. Tubes may be warmed in a water bath to help dissolve samples.**
  - 11.5.15. If solids remain in the original 225 mL tubes, add 5 mL of 1.5M HCl to each tube containing solids, cap, and mix well. Centrifuge for 5 minutes and add the supernate to the sample solution from step 11.5.14. Discard any remaining solids.
  - 11.5.16. Set aside for <sup>226</sup>Ra analysis using *Rapid Radiochemical Method for Radium-226 in Building Materials for Environmental Remediation Following Radiological Incidents* (Reference 16.3).



## 12. Data Analysis and Calculations

- 12.1. Equations for determination of final result, combined standard uncertainty, and radiochemical yield (if required) are found in the corresponding chemical separation and analysis methods, with the project manager providing the units.
- 12.2. In cases where samples have elevated activity, smaller initial sample aliquants may be taken from the original sample. Alternately, smaller aliquant volumes may be taken from the final sample volume containing the dissolved precipitate (digestate). Aliquants should be removed carefully and accurately from this final sample volume.

**NOTE: Small aliquants taken from the final sample digestate for Sr and Ra analysis may be used in the respective analytical procedures as is. Smaller aliquants for actinide analysis should be diluted to a 15 mL total volume with 3M HNO<sub>3</sub> so that load solution acidity is maintained when valence adjustment reagents are added.**

For a single split, the effective size of sample is calculated:

$$W_a = W_s \frac{D_a}{D_s} \quad (1)$$

Where:

- $W_s$  = original sample size, in the units designated by the project manager (e.g., 1 g, etc.)
- $D_s$  = mass or volume of the entire final digestate, (e.g., 20 mL, etc.).
- $D_a$  = mass or volume of the aliquant of digestate used for the individual analyses, (e.g., 5.0 mL, etc.). Note that the values for  $D_a$  must be in the same units used in  $D_s$ .
- $W_a$  = sample aliquant size, used for analysis, in the units designated by the project manager (e.g., kg, g, etc.).

**NOTE: For higher activity samples, additional dilution may be needed. In such cases, Equation 1 should be modified to reflect the number of splits and dilutions performed. It is also important to measure the masses or volumes, used for aliquanting or dilution, to enough significant figures so that their uncertainties have an insignificant impact on the final uncertainty budget. In cases where the sample will not be split prior to analysis, the sample aliquant size is simply equal to the original sample size, in the same units requested by the project manager.**

## 13. Method Performance

- 13.1. Report method validation results.
- 13.2. The method performance data for the analysis of concrete and brick by this dissolution method may be found in the attached appendices.
- 13.3. Expected turnaround time per sample
  - 13.3.1. For a representative, finely ground 1-g aliquant of sample, the fusion should add approximately 2 hours per batch to the time specified in the individual chemical separation methods.
  - 13.3.2. The preconcentration steps should add approximately 2 to 2.5 hours per batch.

**NOTE: Processing times for the subsequent chemical separation methods are given in those methods for batch preparations.**

#### 14. Pollution Prevention

This method inherently produces no significant pollutants. The sample and fusion reagents are retained in the final product and are carried into the ensuing chemical separation techniques, which marginally increases the salt content of the effluent waste. It is noted that if the sampled particulates include radionuclides that may be volatile under the fusion conditions, these constituents will be exhausted through the fume hood system.

#### 15. Waste Management

15.1. Refer to the appropriate chemical separation methods for waste disposal information.

#### 16. References

##### *Cited References*

- 16.1. U.S. Environmental Protection Agency (EPA). 2013. Rapid Radiochemical Method for Americium-241 in Building Materials for Environmental Remediation Following Radiological Incidents. Revision 0, EPA 402-R14-007. Office of Air and Radiation, Washington, DC. Available at: [www.epa.gov/narel](http://www.epa.gov/narel).
- 16.2. U.S. Environmental Protection Agency (EPA). 2013. Rapid Radiochemical Method for Pu-238 and Pu-239/240 in Building Materials for Environmental Remediation Following Radiological Incidents. Revision 0, EPA 402-R14-006. Office of Air and Radiation, Washington, DC. Available at: [www.epa.gov/narel](http://www.epa.gov/narel).
- 16.3. U.S. Environmental Protection Agency (EPA). 2013. Rapid Radiochemical Method for Radium-226 in Building Materials for Environmental Remediation Following Radiological Incidents. Revision 0, EPA 402-R14-002. Office of Air and Radiation, Washington, DC. Available at: [www.epa.gov/narel](http://www.epa.gov/narel).
- 16.4. U.S. Environmental Protection Agency (EPA). 2013. Rapid Radiochemical Method for Total Radiostrontium (Sr-90) in Building Materials for Environmental Remediation Following Radiological Incidents. Revision 0, EPA 402-R14-001. Office of Air and Radiation, Washington, DC. Available at: [www.epa.gov/narel](http://www.epa.gov/narel).
- 16.5. U.S. Environmental Protection Agency (EPA). 2013. Rapid Radiochemical Method for Isotopic Uranium in Building Materials for Environmental Remediation Following Radiological Incidents. Revision 0, EPA 402-R14-005. Office of Air and Radiation, Washington, DC. Available at: [www.epa.gov/narel](http://www.epa.gov/narel).
- 16.6. U.S. Environmental Protection Agency (EPA). 2009. *Method Validation Guide for Qualifying Methods Used by Radiological Laboratories Participating in Incident Response Activities*. Revision 0. Office of Air and Radiation, Washington, DC. EPA 402-R-09-006, June. Available at: [www.epa.gov/narel](http://www.epa.gov/narel).
- 16.7. U.S. Environmental Protection Agency (EPA). 2012. *Radiological Laboratory Sample Analysis Guide for Incident Response — Radionuclides in Soil*. Revision 0. Office of

Air and Radiation, Washington, DC. EPA 402-R-12-006, September 2012. Available at: [www.epa.gov/narel](http://www.epa.gov/narel).

- 16.8. MARLAP. *Multi-Agency Radiological Laboratory Analytical Protocols Manual*. 2004. Volumes 1 – 3. Washington, DC: EPA 402-B-04-001A-C, NUREG 1576, NTIS PB2004-105421, July. Available at: [www.epa.gov/radiation/marlap](http://www.epa.gov/radiation/marlap).
- 16.9. ASTM D1193, “Standard Specification for Reagent Water” ASTM Book of Standards 11.01, current version, ASTM International, West Conshohocken, PA.

*Other References*

- 16.10. Maxwell, S., Culligan, B. and Noyes, G. 2010. Rapid method for actinides in emergency soil samples, *Radiochimica Acta*. 98(12): 793-800.
- 16.11. Maxwell, S., Culligan, B., Kelsey-Wall, A. and Shaw, P. 2011. “Rapid Radiochemical Method for Actinides in Emergency Concrete and Brick Samples,” *Analytica Chimica Acta*. 701(1): 112-8.
- 16.12. U.S. Environmental Protection Agency (EPA). 2010. *Rapid Radiochemical Methods for Selected Radionuclides in Water for Environmental Restoration Following Homeland Security Events*, Office of Air and Radiation. EPA 402-R-10-001, February. Revision 0.1 of rapid methods issued October 2011. Available at: [www.epa.gov/narel/](http://www.epa.gov/narel/).

17. Tables, Diagrams, and Flow Charts

17.1. Fusion Flow Chart

**Timeline for Rapid Fusion and Preparation of Building Materials Samples for Precipitation and Analysis**

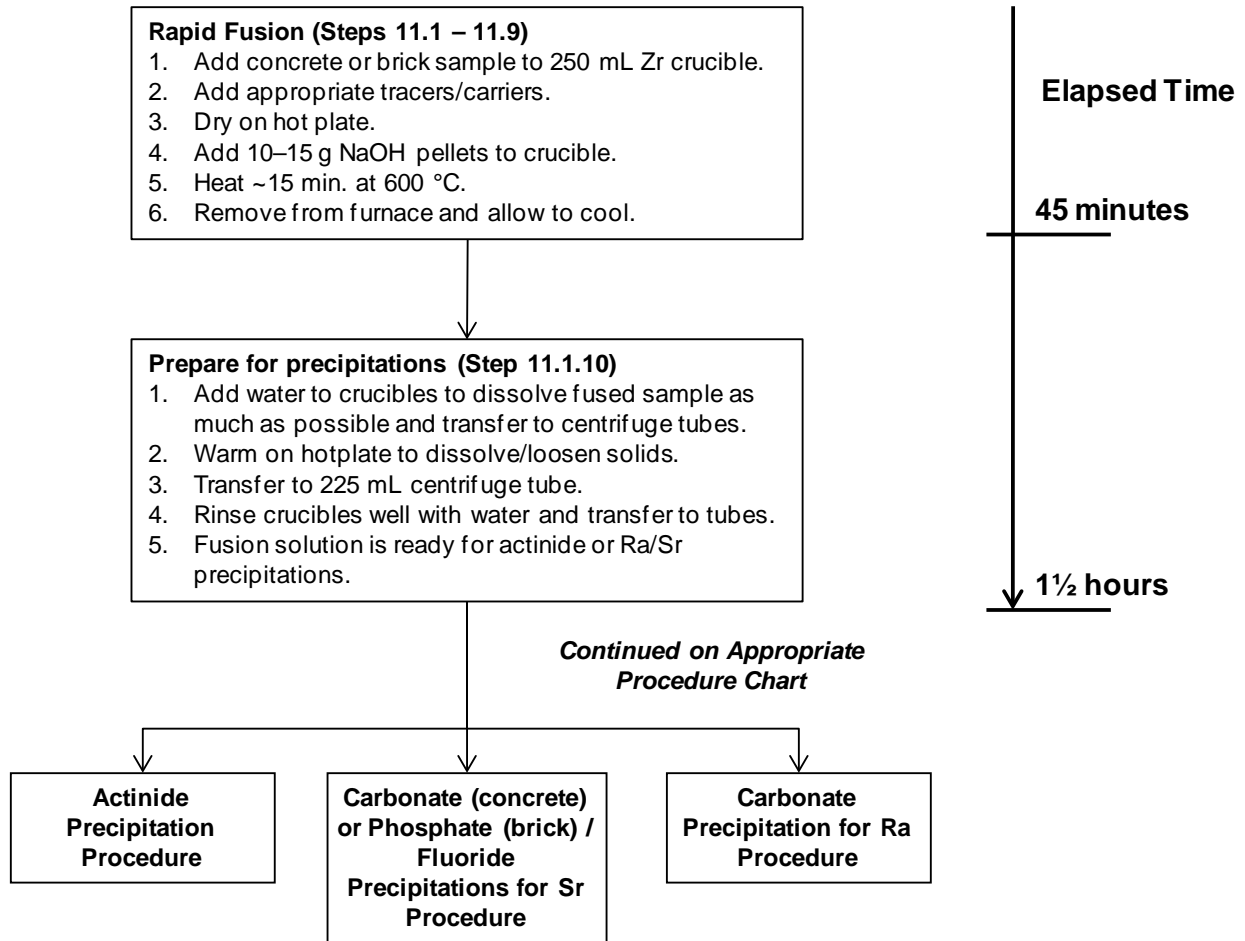

## 17.2. Actinide Precipitation Flow Chart

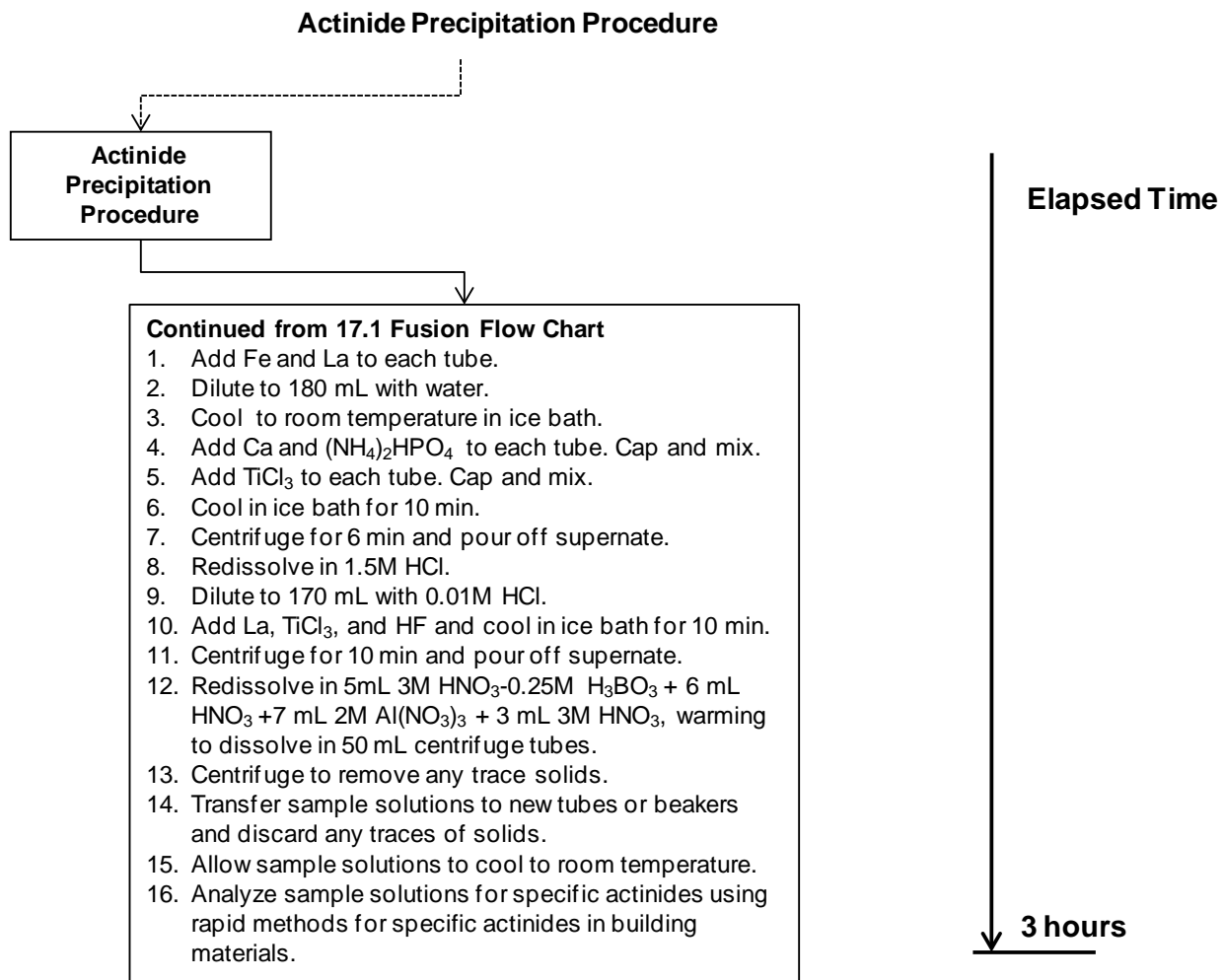

17.3. Strontium Precipitation Flow Chart

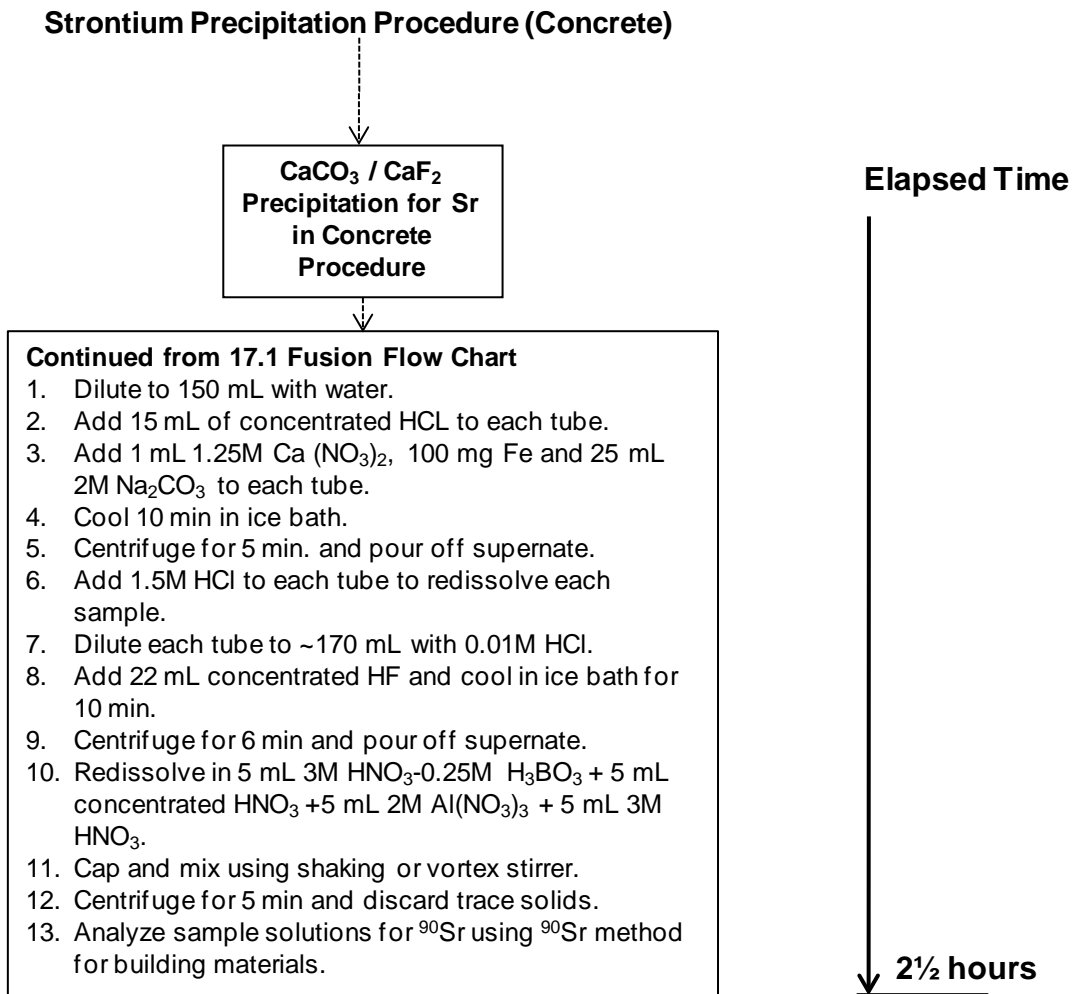

### Strontium Precipitation Procedure (Brick)

$\text{Ca}_3(\text{PO}_4)_2$  /  $\text{CaF}_2$   
Precipitation for Sr  
in Brick Procedure

#### Continued from 17.1 Fusion Flow Chart

1. Dilute to 150 mL with water.
2. Add 2 mL 1.25M  $\text{Ca}(\text{NO}_3)_2$ , 50 mg Fe, and 5 mL 3.2M  $(\text{NH}_4)_2\text{HPO}_4$  to each tube.
3. Centrifuge for 5 min and pour off supernate.
4. Redissolve in ~60 mL 1.5M HCL.
5. Dilute to 170 mL with 0.01M HCl.
6. Add 22 mL Concentrated HF and wait 10 min.
7. Centrifuge for 6 min and pour off supernate.
8. Redissolve in 5 mL 3M  $\text{HNO}_3$ -0.25M  $\text{H}_3\text{BO}_3$  + 5 mL concentrated  $\text{HNO}_3$  + 5 mL 2M  $\text{Al}(\text{NO}_3)_3$  + 5 mL 3M  $\text{HNO}_3$ .
9. Cap and mix using vortex stirrer.
10. Centrifuge for 5 min and discard trace solids.
11. Analyze sample solutions for  $^{90}\text{Sr}$  using  $^{90}\text{Sr}$  method for building materials.

Elapsed Time

2½ hours

#### 17.4. Radium Precipitation Flow Chart

##### Carbonate Precipitation for Radium Procedure

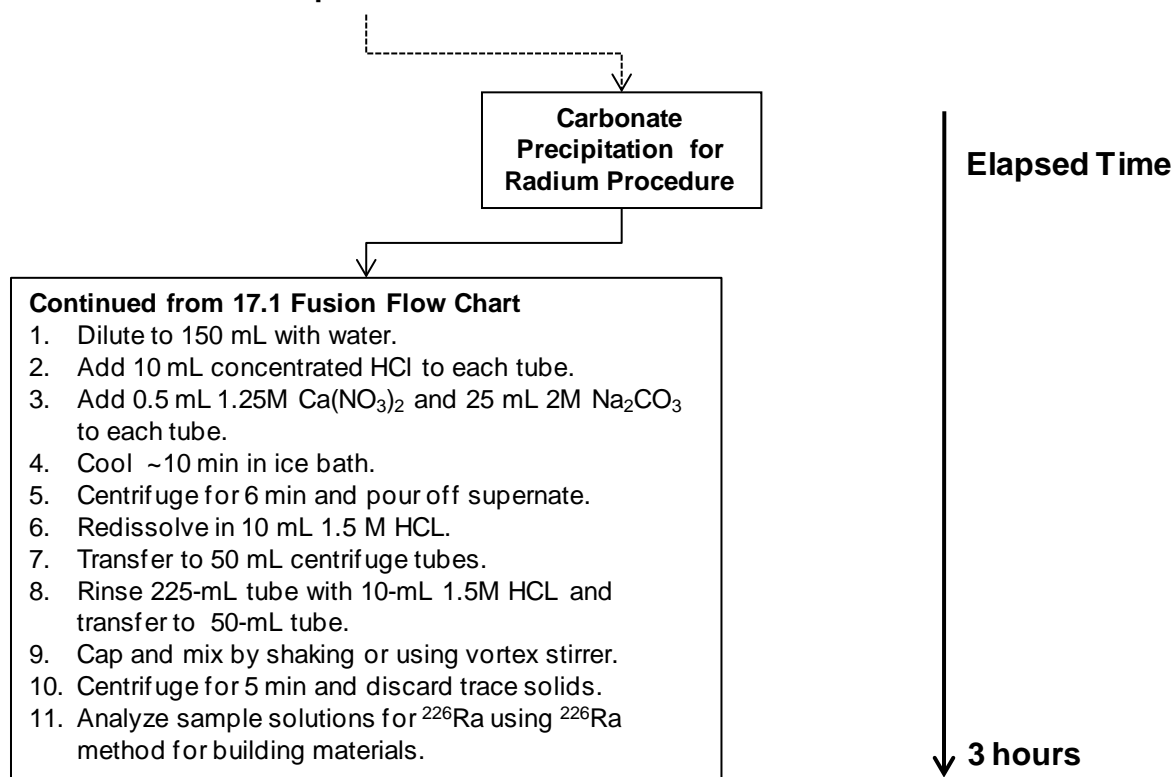



## Appendix:

### Rapid Technique for Milling and Homogenizing Concrete and Brick Samples

#### A1. Scope and Application

- A1.1. Concrete or brick samples may be received as powder, core samples or other size pieces or chunks. The goal is to obtain representative sample aliquants from homogeneous amounts of sample.
- A1.2. The ball mill method describes one approach for the rapid, gross preparation of concrete or brick samples to yield representative 1–2-g aliquant for radiochemical analysis of non-volatile radionuclides. The method addresses steps for splitting, drying, and milling of 50–2,000 g concrete or brick samples. The concrete or brick sample must be reduced to pieces or fragments less than ~25 mm in diameter prior to using the ball mill. This can be done with a hydraulic press or mallet.
- A1.3. The method is designed to be used as a preparatory step for the attached methods for fusion of concrete or brick for  $^{241}\text{Am}$ ,  $^{239/240}\text{Pu}$ , U,  $^{90}\text{Sr}$ , and  $^{226}\text{Ra}$ . It may also be applied to other matrices whose physical form is amenable to pulverization in the ball mill.
- A1.4. If the levels of activity in the sample are low enough to permit safe radiological operations, up to 2 kg of concrete or brick can be processed.
- A1.5. For smaller amounts of concrete or brick samples, a drill with masonry bit can be used in a lab hood inside a plastic bag to collect the powder that results.

#### A2. Summary of Methods

- A2.1. This method uses only disposable equipment to contact the sample, minimizing the risk of contamination and cross-contamination and eliminating concerns about adequate cleaning of equipment.
- A2.2. Extraneous material, such as rocks or debris, may be removed prior to processing the sample unless the project requires that they be processed as part of the sample.  
**NOTE: The sample mass is generally used for measuring the size of solid samples. The initial process of acquiring a representative aliquant uses the volume of the sample, as the total sample size is generally based on a certain volume of concrete or brick (e.g., 500 mL).**
- A2.3. The entire sample as received (after reducing fragment size to less than ~25 mm diameter) is split by coning and quartering until 75-150 mL of concrete or brick are available for subsequent processing. If less than 450 mL of concrete or brick is received, the entire sample is processed.
- A2.4. The concrete or brick is transferred to a paint can or equivalent. Percent solids are determined, if required, by drying in a drying oven. A mallet and plastic bag or hydraulic press may be needed to break up larger pieces.
- A2.5. Grinding media (stainless steel or ceramic balls or rods) are added, and the sample is milled to produce a finely-ground, well-homogenized, powder with predominant particle size less than 250 micrometers ( $\mu\text{m}$ ).

**NOTE: A mortar and pestle may also be used as needed to grind the sample further.**

- A2.6. If the sample may contain discreet radioactive particles (DRPs), particles larger than a nominal size of 150  $\mu\text{m}$  are screened for radioactivity, and further milled, or processed with another appropriate method to ensure that they will be chemically available for subsequent processing.
  - A2.7. The resulting milled sample is stored in, and aliquanted directly from, the container used for pulverization.
  - A2.8. The drill bit method involves drilling into the sample using a drill bit. The operation is performed inside a disposable plastic bag in a hood so that the drilled out sample is caught within the plastic bag (this approach also minimizes the spread of contamination). A drill bit such as a 1/4-inch carbide bit is recommended. The holes should be drilled in such a way as to obtain representative powdered samples. The drill bit should be cleaned between uses on different samples using soap and water.
- A3. Definitions, Abbreviations, and Acronyms
- A3.1. Discrete Radioactive Particles (DRPs or “hot particles”). Particulate matter in a sample of any matrix where a high concentration of radioactive material is contained in a tiny particle ( $\mu\text{m}$  range).
  - A3.2. *Multi-Agency Radiological Analytical Laboratory Protocols (MARLAP) Manual* (Reference A16.3).
  - A3.3. *ASTM C999 Standard Practice for Soil Sample Preparation for the Determination of Radionuclides* (Reference A16.4).
- A4. Interferences
- A4.1. Radiological Interferences
    - A4.1.1. Coning and quartering provides a mechanism for rapidly decreasing the overall size of the sample that must be processed while optimizing the representativeness of the subsampling process. By decreasing the time and effort needed to prepare the sample for subsequent processing, sample throughput can be significantly improved. Openly handling large amounts of highly contaminated materials, however, even within the containment provided by a fume hood, may pose an unacceptable risk of inhalation of airborne contamination and exposure to laboratory personnel from radioactive or other hazardous materials. Similarly, it may unacceptably increase the risk of contamination of the laboratory.
    - A4.1.2. In such cases, the coning and quartering process may be eliminated in lieu of processing the entire sample. The time needed to dry the sample will increase significantly, and the container size and the number and size of grinding media used will need to be adjusted to optimize the milling process. See *ASTM C999* for an approach for homogenization and milling of larger soil samples.

- A4.1.3. The precise particle size of the milled sample is not critical to subsequent processes. However, milling the sample to smaller particle sizes, and thorough mixing, both facilitate representative sub-sampling by minimizing the amount of sample that is not pulverized to fine mesh and must be discarded. Additionally, subsequent fusion and digestion processes are more effective when performed on more finely milled samples.
- A4.1.4. This method assumes that radioactivity in the sample is primarily adsorbed onto the surface of particles, as opposed to being present as a hot particle (see discussion of DRPs below). Thus, nearly all of the activity in a sample will be associated with sample fines. By visually comparing the sample to a qualitative standard of 50–100 mesh size particles, it is possible to rapidly determine whether the sample is fine enough to facilitate the subsequent fusion or digestion. This method assumes that when greater than 95% of the sample is as fine or finer than the 50–100 mesh sample, bias imparted from losses of larger particles will be minimal.
- A4.1.5. If the sample was collected near the epicenter of a radiological dispersal device (RDD) or improvised nuclear device (IND) explosion, it may contain millimeter- to micrometer-sized particles of contaminant referred to as “discrete radioactive particles” or DRPs. DRPs may consist of small pieces of the original radioactive source and thus may have very high specific activity. They may also consist of chemically intractable material and present special challenges in the analytical process. Even when the size is reduced to less than 50-100 mesh, these particles may resist fusion or digestion of the solids into ionic form that can be subjected to chemical separations.
- A4.1.6. When DRPs may be present, this method isolates larger particles by passing the sample through a disposable 50-mesh screen after which they can be reliably checked for radioactivity. DRPs may reliably be identified by their very high specific activity, which is readily detectable, since they show high count rates using hand-held survey equipment such as a thin-window Geiger-Muller (G-M) probe.
- A4.1.7. When present, DRPs may be further milled and then recombined with the original sample. Alternatively, the particles, or the entire sample may need to be processed using a different method capable of completely solubilizing the contaminants such that the radionuclides they contain are available for subsequent chemical separation.

## A5. Safety

### A5.1. General

- A5.1.1. Refer to your safety manual for concerns of contamination control, personal exposure monitoring, and radiation dose monitoring.

A5.1.2. Refer to your laboratory's chemical hygiene plan (or equivalent) for general safety rules regarding chemicals in the workplace.

A5.2. Radiological

A5.2.1. Refer to your radiation safety manual for direction on working with known or suspected radioactive materials.

A5.2.2. This method has the potential to generate airborne radioactive contamination. The process should be carefully evaluated to ensure that airborne contamination is maintained at acceptable levels. This should take into account the activity level, and physical and chemical form of contaminants possibly present, as well as other engineering and administrative controls available.

A5.2.3. Hot Particles (DRPs)

A5.2.3.1. Hot particles will usually be small, on the order of 1 mm or less. Typically, DRPs are not evenly distributed in the media, and their radiation emissions are not uniform in all directions (anisotropic). Filtration using a 0.45  $\mu\text{m}$  or smaller filter may be needed following subsequent fusion to identify the presence of smaller DRPs.

A5.2.3.2. Care should be taken to provide suitable containment for filter media used in the pretreatment of samples that may have DRPs, because the particles become highly statically charged as they dry out and will "jump" to other surfaces potentially creating contamination-control issues.

A5.3. Method-Specific Non-Radiological Hazards

A5.3.1. This method employs a mechanical shaker and should be evaluated for personnel hazards associated with the high kinetic energy associated with the milling process.

A5.3.2. This method employs a mechanical shaker and involves vigorous agitation of steel or ceramic balls inside steel cans. The process should be evaluated to determine whether hearing protection is needed to protect the hearing of personnel present in the area in which the apparatus is operated.

A6. Equipment and supplies

A6.1. Balance, top-loading, range to accommodate sample size encountered, readability to  $\pm 1\%$ .

A6.2. Drying oven, at  $110 \pm 10$  °C.

A6.3. Steel paint cans and lids (pint, quart, 2-quart, 1-gallon, as needed).

A6.4. Steel or ceramic grinding balls or rods for ball milling, ~15–25 mm diameter. The size and number of grinding media used should be optimized to suit the types of concrete or brick, the size of the can, and the volume of sample processed.

A6.5. Disposable wire cloth – nominal 48 mesh size (~300  $\mu\text{m}$ ).

- A6.6. Disposable sieves, U.S. Series No. 50 (300  $\mu\text{m}$  or 48 mesh) and U.S. Series No. 100 (150  $\mu\text{m}$  or 100 mesh).
- A6.7. Red Devil 5400 mechanical paint shaker or equivalent.
- A6.8. Disposable scoop, scraper, tongue depressor or equivalent.
- A7. Reagents and Standards  
No reagents needed.
- A8. Sample Collection, Preservation and Storage
- A8.1. Samples should be collected in appropriately sized plastic, metal or glass containers.
- A8.2. No sample preservation is required. If samples are to be held for an extended period of time, refrigeration may help minimize bacterial growth in the sample.
- A8.3. Default sample collection protocols generally provide solid sample volumes equivalent to approximately 500 mL of sample. Such samples will require two splits to obtain a ~100 mL sample.
- A9. Quality Control
- A9.1. Batch quality control results shall be evaluated and meet applicable Analytical Protocol Specifications (APS) prior to release of unqualified data. In the absence of project-defined APS or a project-specific quality assurance project plan (QAPP), the quality control sample acceptance criteria defined in the laboratory quality manual and procedures shall be used to determine acceptable performance for this method.
- A9.2. Quality control samples should be initiated as early in the process as possible. Since the risk of cross-contamination using this process is relatively low, initiating blanks and laboratory control samples at the start of the chemical separation process is acceptable. If sufficient sample is available, a duplicate sample should be prepared from the two discarded quarters of the final split of the coning and quartering procedure.
- A10. Procedure
- NOTE: This method ensures that only disposable equipment comes in contact with sample materials to greatly minimize the risk of sample cross-contamination and concerns about adequate cleaning of equipment. Under certain circumstances (disposable sieves are not available, for example), careful, thorough cleaning of the sieves with water and the ethanol may be an option.**
- A10.1. If necessary, reduce the concrete or brick particle diameter to less than ~25 mm using a hydraulic press, mallet, or alternate equipment capable of reducing the fragment size.
- A10.2. Estimate the total volume of sample, as received.
- NOTE: If the sample is dry, the risk of resuspension and inhalation of the solids may be determined to be unacceptable. In such cases, the entire sample may be processed in a larger can. The drying and milling time will be increased, and more grinding media will be required to obtain a satisfactory result.**

**NOTE: The next step uses absorbent paper in the reverse fashion for the normal use of this type of paper; it allows for a smooth division of the sample and control of contamination.**

- A10.2.1. Spread a large piece of plastic backed absorbent paper, plastic side *up* in a hood.
- A10.2.2. If the sample volume is less than 450 mL, there is no benefit to coning and quartering.<sup>5</sup>
- A10.2.2.1. Carefully pour the sample onto the paper.
- A10.2.2.2. Remove extraneous material, such as rocks or debris, unless the project requires that such material be processed as part of the sample. Continue with Step A10.2.5.
- A10.2.3. If the sample volume is greater than ~450 mL, carefully pour the entire sample into a cone onto the paper.
- Remove extraneous material, such as rocks or debris unless the project requires that such material be processed as part of the sample.
- A10.2.4. If levels of gross activity in the sample permit, the sample is split at least twice using the coning and quartering steps that follow.

**NOTE: Unused quarters are considered representative of the original sample and may be reserved for additional testing. The process should be carried out expediently to minimize loss of volatile components in the sample, especially if volatile components or percent solids are to be determined.**

A10.2.4.1. Spread the material into a flat circular cake of soil using a tongue depressor or other suitable disposable implement. Divide the cake radially and return two opposing quarters to the original sample container.

A10.2.4.2. Reshape the remaining two quarters into a smaller cone, and repeat Step A10.2.2.1 until the total volume of the remaining material is approximately 100-150 mL.

**NOTE: Tare the can and lid together. Do not apply an adhesive label. Rather, label the can with permanent marker since the can will be placed in a drying oven. The lid should be labeled separately since it will be removed from the can during drying.**

- A10.2.5. Transfer the coned and quartered sample to a tared, labeled 1-pint paint can. If the total volume was less than ~450 mL, transfer the entire sample to a tared, labeled 1-quart paint can.

**NOTE: Constant mass may be determined by removing the container from the oven and weighing repeatedly until the mass remains constant with within 1% of the starting mass of the sample. This determination may also be achieved**

---

<sup>5</sup> International Union of Pure and Applied Chemistry (IUPAC). 1997. Compendium 1675 of Chemical Terminology, 2<sup>nd</sup> ed. (the "Gold Book"). Compiled by A. D. (Reference A16.1).

**operationally by observing the time needed to ensure that 99% of the samples will obtain constant mass.**

A10.3. Place the can (without lid) in an oven at  $110 \pm 10$  °C and dry the concrete or brick to constant mass.

**NOTE: Concrete or brick samples may be dry enough such that heating prior to homogenizing the sample is not required.**

A10.4. Weigh the combined mass of the can, sample, and lid. If the percent solids are required see Section A12.1 calculations. Remove can from oven and allow to cool.

A10.5. Add five 1.5 cm stainless steel or ceramic balls or rods to the can. Replace the lid and seal well.

A10.6. Shake the can and contents for 5 minutes, or longer, as needed to produce a finely-milled, well-homogenized, sample.

**NOTE: Although the precise particle size of the milled sample is not critical, complete pulverization and fine particle size facilitates representative sub-sampling and subsequent fusion or digestion processes. A qualitative standard can be prepared by passing quartz sand or other milled material through a 50-mesh and then a 100-mesh screen. The portion of the sample retained in the 100 mesh screen can be used as a qualitative visual standard to determine if samples have been adequately pulverized.**

A10.7. Visually compare the resulting milled sample to a qualitative 50–100 mesh pulverized sample (~150–300  $\mu\text{m}$  or 50–100 mesh using the Tyler screen scale). The process is complete once 95% of the sample (or greater) is as fine, or finer, than the qualitative standard. If, by visual estimation, more than ~5% of total volume of the particles in the sample appear to be larger than the particle size in the standard, return the sample to the shaker and continue milling until the process is complete.

A10.8. Following milling, a small fraction of residual larger particles may remain in the sample.

A10.8.1. If the sample was collected close to the epicenter of an RDD or IND explosion, it may also contain particles of contaminant referred to as “discrete radioactive particles” or DRPs. In such a case, the larger particles should be isolated by passing through a disposable 48 mesh screen and checked for radioactivity. DRPs are readily identified by their very high specific activity which is detectable using hand-held survey equipment such as a thin-window G-M probe held within an inch of the particles.

A10.8.1.1. If radioactivity is clearly detected, the sieved material is returned to the can and ball milled until the desired mesh is obtained. In some cases, these materials may be resistant to further pulverization and may need to be processed according to a method specially designed to address highly intractable solids.

A10.8.1.2. If the presence of DRPs is of no concern, the larger particles need not be included in subsequent subsamples taken for analysis. It may be possible to easily avoid including them during aliquanting with a disposable scoop. If not, however, they should be removed by sieving through a nominal 50 mesh screen (disposable) prior to further subsampling for subsequent analyses.

A10.9. Sample fines may be stored in, and aliquanted directly from, the container used for drying and pulverization.

A11. Calibration and Standardization

A11.1. Balances used shall be calibrated using National Institute of Standards and Technology (NIST)-traceable weights according to the process defined by the laboratory's quality manual.

A12. Data Analysis and Calculations

A12.1. The percent solids (dry-to-as-received mass ratio) for each sample is calculated from data obtained during the preparation of the sample as follows:

$$\% \text{ Solids} = \frac{M_{\text{dry}} - M_{\text{tare}}}{M_{\text{as rec}} - M_{\text{tare}}} \times 100$$

Where:

$M_{\text{dry}}$  = mass of dry sample + labeled can + lid (g)

$M_{\text{tare}}$  = tare mass of labeled can + lid (g)

$M_{\text{as rec}}$  = mass of sample as received + labeled can + lid (g)

A12.2. If requested, convert the equivalent mass of sample, as received, to dry mass. Dry mass is calculated from a measurement of the total as received mass of the sample received as follows:

$$\text{Dry Sample Equivalent} = M_{\text{total-as rec.}} \times \frac{\% \text{ Solids}}{100}$$

Where:

$M_{\text{total-as rec.}}$  = total mass of sample, as received (g)

A12.3. Results Reporting

A12.3.1. The result for percent solids and the approximate total mass of sample as received should generally be reported for each result.

A13. Method Performance

A13.1. Results of method validation performance are to be archived and available for reporting purposes.

A13.2. Expected turnaround time is about 3 hours for an individual sample and about 4 hours per batch.

A14. Pollution Prevention.



Not applicable

A15. Waste Management

A15.1. All radioactive and other regulated wastes shall be handled according to prevailing regulations.

A16. References

A16.1. International Union of Pure and Applied Chemistry (IUPAC). 1997. Compendium of Chemical Terminology, 2<sup>nd</sup> ed. (the “Gold Book”). Compiled by A. D. McNaught and A. Wilkinson. Blackwell Scientific Publications, Oxford. XML on-line corrected version: <http://goldbook.iupac.org/C01265.html>. (2006) created by M. Nic, J. Jirat, B. Kosata; updates compiled by A. Jenkins. Last update: 2010-12-22.

A16.2. ALS Laboratories, Fort Collins, SOP 736.

A16.3. MARLAP. *Multi-Agency Radiological Laboratory Analytical Protocols Manual*. 2004. Volumes 1 – 3. Washington, DC: EPA 402-B-04-001A-C, NUREG 1576, NTIS PB2004-105421, July. Available at: [www.epa.gov/radiation/marlap](http://www.epa.gov/radiation/marlap).

A16.4. ASTM C 999-05, “Standard Practice for Soil Sample Preparation for the Determination of Radionuclides,” Volume 12.01, ASTM, 2005.

**Attachment III:****Rapid Radiochemical Method for Pu-238 and Pu-239/240 in Building Materials for Environmental Remediation Following Radiological Incidents**

## 1. Scope and Application

- 1.1. The method will be applicable to samples where contamination is either from known or unknown origins.
- 1.2. The method is specific for  $^{238}\text{Pu}$  and  $^{239/240}\text{Pu}$  in solid samples such as building materials (concrete, brick, etc.).
- 1.3. The method uses rapid radiochemical separation techniques to determine alpha-emitting plutonium isotopes in building material samples following a nuclear or radiological incident.
- 1.4. The method cannot distinguish between  $^{239}\text{Pu}$  and  $^{240}\text{Pu}$  and any results are reported as the total activity of the two radionuclides.
- 1.5. The method is capable of achieving a required method uncertainty ( $u_{\text{MR}}$ ) for  $^{238}\text{Pu}$  or  $^{239/240}\text{Pu}$  of 0.25 pCi/g at an analytical action level (AAL) of 1.89 pCi/g, a required relative uncertainty ( $\phi_{\text{MR}}$ ) of 13% above the AAL, and a minimum detectable concentration (MDC) of 0.20 pCi/g. To attain the required method uncertainty at the AAL, a sample weight of approximately 1 g and count time of at least 3 to 4 hours are recommended. The sample turnaround time and throughput may vary based on additional project measurement quality objectives (MQOs), the time for analysis of the sample test source, and initial sample weight/volume. The method must be validated prior to use following the protocols provided in *Method Validation Guide for Qualifying Methods Used by Radiological Laboratories Participating in Incident Response Activities* (EPA 2009, Reference 16.1).
- 1.6. The rapid plutonium method was initially validated for concrete building materials following the guidance presented for “Level E Method Validation: Adapted or Newly Developed Methods, Including Rapid Methods” in *Method Validation Guide for Qualifying Methods Used by Radiological Laboratories Participating in Incident Response Activities* (EPA 2009, Reference 16.1) and Chapter 6 of *Multi-Agency Radiological Laboratory Analytical Protocols Manual* (EPA 2004, Reference 16.2). Subsequent building material matrices were validated at Level C (“Similar Matrix/New Application”). Note that this method cannot distinguish between  $^{239}\text{Pu}$  and  $^{240}\text{Pu}$  and only the sum of the activities of these two isotopes can be determined.
- 1.7. Multi-radionuclide analysis using sequential separation may be possible using this method in conjunction with other rapid methods (see appendix). Rapid methods can also be used for routine analyses with appropriate (typically longer) count times.
- 1.8. Other solid samples such as soil can be digested using the rapid sodium hydroxide fusion procedure as an alternative to other digestion techniques, but the laboratory will have to validate this procedure.
- 1.9. This method may also be used in combination with the fusion procedure for Radioisotope Thermoelectric Generator (RTG) materials in water and air filter samples.

- 1.10. This method has also been used to determine  $^{237}\text{Np}$  by using  $^{236}\text{Pu}$  tracer. This was not tested, however, and would require validation by the laboratory.
- 1.11. Other methods for sample test source preparation, such as microprecipitation with neodymium fluoride, may be used in lieu of the cerium fluoride microprecipitation, but any such substitution must be validated as described in Step 1.5.
- 1.12. Electroplating may not be used with the Pu strip solution containing titanium, which interferes with electrodeposition. A reductant such as rongalite (sodium formaldehyde sulfoxylate) may be used instead of titanium if electrodeposition is used but this must be validated by the laboratory.

## 2. Summary of Method

- 2.1. This method is based on the use of TEVA<sup>®</sup> Resin (Aliquat 336 extractant-coated resin) to isolate and purify plutonium by removing interfering radionuclides as well as other components of the matrix in order to prepare the plutonium fraction for counting by alpha spectrometry. The method utilizes vacuum-assisted flow to improve the speed of the separations. The sample may be fused using the procedure *Rapid Method for Sodium Hydroxide Fusion of Concrete and Brick Matrices Prior to Americium, Plutonium, Strontium, Radium, and Uranium Analyses* (Reference 16.3), with the plutonium isotopes then removed from the fusion matrix using iron hydroxide and lanthanum fluoride precipitation steps.  $^{242}\text{Pu}$  or  $^{236}\text{Pu}$  tracer, added to the building materials sample, is used as a yield monitor. The sample test source is prepared by microprecipitation with  $\text{CeF}_3$ . Standard laboratory protocol for the use of an alpha spectrometer should be used when the sample is ready for counting.

## 3. Definitions, Abbreviations, and Acronyms

- 3.1. Analytical Protocol Specifications (APS). The output of a directed planning process that contains the project's analytical data needs and requirements in an organized, concise form.
- 3.2. Analytical Action Level (AAL). The term "analytical action level" is used to denote the value of a quantity that will cause the decision-maker to choose one of the alternative actions.
- 3.3. Discrete Radioactive Particles (DRPs or "hot particles"). Particulate matter in a sample of any matrix where a high concentration of radioactive material is contained in a tiny particle ( $\mu\text{m}$  range).
- 3.4. *Multi-Agency Radiological Analytical Laboratory Protocols Manual* (MARLAP) provides guidance for the planning, implementation, and assessment phases of those projects that require the laboratory analysis of radionuclides (Reference 16.2).
- 3.5. Measurement Quality Objective (MQO). MQOs are the analytical data requirements of the data quality objectives and are project- or program-specific. They can be quantitative or qualitative. MQOs serve as measurement performance criteria or objectives of the analytical process.

- 3.6. Radiological Dispersal Device (RDD), i.e., a “dirty bomb.” This device is an unconventional weapon constructed to distribute radioactive material(s) into the environment either by incorporating them into a conventional bomb or by using sprays, canisters, or manual dispersal.
  - 3.7. Required Method Uncertainty ( $u_{MR}$ ). The required method uncertainty is a target value for the individual measurement uncertainties, and is an estimate of uncertainty (of measurement) before the sample is actually measured. The required method uncertainty is applicable below an AAL.
  - 3.8. Relative Required Method Uncertainty ( $\phi_{MR}$ ). The relative required method uncertainty is the  $u_{MR}$  divided by the AAL and is typically expressed as a percentage. It is applicable above the AAL.
  - 3.9. Sample Test Source. This is the final form of the sample that is used for nuclear counting. This form is usually specific for the nuclear counting technique used in the method such as a solid deposited on a filter for alpha spectrometry analysis.
4. Interferences
    - 4.1. Radiological
      - 4.1.1. Alpha-emitting radionuclides with irresolvable alpha energies, such as  $^{238}\text{Pu}$  (5.50 MeV),  $^{241}\text{Am}$  (5.48 MeV), and  $^{228}\text{Th}$  (5.42 MeV) must be chemically separated to enable measurement. This method separates these radionuclides effectively. The individual detector’s alpha energy resolution and the quality of the final precipitate that is counted will determine the significance of peak overlap.
      - 4.1.2. Vacuum box lid and holes must be cleaned frequently to prevent cross-contamination of samples.
    - 4.2. Non-Radiological: Very high levels of anions such as phosphates may lead to lower yields due to competition with active sites on the resin and/or complexation with plutonium ions. Aluminum is added in the column load solution to complex interfering anions such as fluoride and phosphate.
5. Safety
    - 5.1. General
      - 5.1.1. Refer to your safety manual for concerns of contamination control, personal exposure monitoring, and radiation dose monitoring.
      - 5.1.2. Refer to your laboratory’s chemical hygiene plan (or equivalent) for general safety rules regarding chemicals in the workplace.
    - 5.2. Radiological
      - 5.2.1. Hot particles (DRPs)
        - 5.2.1.1. Hot particles, also termed “discrete radioactive particles” (DRPs), will be small, on the order of 1 mm or less. Typically, DRPs are not evenly distributed in the media and their radiation emissions are not uniform in all directions (anisotropic).

- 5.2.2. For samples with detectable activity concentrations of these radionuclides, labware should be used only once due to potential for cross contamination.
- 5.3. Procedure-Specific Non-Radiological Hazards: Particular attention should be paid to the use of hydrofluoric acid (HF). HF is an extremely dangerous chemical used in the preparation of some of the reagents and in the microprecipitation procedure. Appropriate personal protective equipment (PPE) must be used in strict accordance with the laboratory safety program specification.
6. Equipment and Supplies
- 6.1. Alpha spectrometer calibrated for use over the range of ~3.5–7 MeV.
  - 6.2. Analytical balance with  $10^{-4}$  g readability, or better.
  - 6.3. Cartridge reservoirs, 10 or 20 mL syringe style with locking device, or reservoir columns (empty luer tip, CC-10-M) plus 12 mL reservoirs (CC-06-M), Image Molding, Denver, Co, or equivalent.
  - 6.4. Centrifuge able to accommodate 225 mL tubes.
  - 6.5. Centrifuge tubes, 50 mL and 225 mL capacity.
  - 6.6. Filter manifold apparatus with 25 mm-diameter polysulfone. A single-use (disposable) filter funnel/filter combination may be used, to avoid cross-contamination.
  - 6.7. 25 mm polypropylene filter, 0.1  $\mu$ m pore size, or equivalent.
  - 6.8. Graduated cylinders, 500 mL and 1000 mL.
  - 6.9. Stainless steel planchets or other adhesive sample mounts (Ex. Environmental Express, Inc. P/N R2200) able to hold the 25 mm filter.
  - 6.10. Tweezers.
  - 6.11. 100  $\mu$ L, 200  $\mu$ L, 500  $\mu$ L, and 1 mL pipets or equivalent and appropriate plastic tips.
  - 6.12. 1-10 mL electronic pipet.
  - 6.13. Vacuum pump or laboratory vacuum system.
  - 6.14. Vacuum box tips, white inner, Eichrom part number AC-1000-IT, or PFA 5/32"x 1/4" heavywall tubing connectors, natural, Ref P/N 00070EE, cut to 1 inch, Cole Parmer, or equivalent.
  - 6.15. Vacuum box tips, yellow outer, Eichrom part number AC-1000-OT, or equivalent.
  - 6.16. Vacuum box, such as Eichrom part number AC-24-BOX, or equivalent.
  - 6.17. Vortex mixer.
  - 6.18. Miscellaneous laboratory ware of plastic or glass; 250 and 500 mL capacities.

7. Reagents and Standards

**NOTES:**

**All reagents are American Chemical Society (ACS) reagent grade or equivalent unless otherwise specified.**

**Unless otherwise indicated, all references to water should be understood to mean Type I reagent water (ASTM D1193, Reference 16.5). All solutions used in microprecipitation should be prepared with water filtered through a 0.45  $\mu$ m (or better) filter.**

- 7.1. Type I reagent water as defined in ASTM Standard D1193 (Reference 16.5).
- 7.2. Aluminum nitrate ( $\text{Al}(\text{NO}_3)_3 \cdot 9\text{H}_2\text{O}$ ).
  - 7.2.1. Aluminum nitrate solution, 2M ( $\text{Al}(\text{NO}_3)_3$ ): Add 750 g of aluminum nitrate ( $\text{Al}(\text{NO}_3)_3 \cdot 9\text{H}_2\text{O}$ ) to ~700 mL of water and dilute to 1 L with water. Low-levels of uranium are typically present in  $\text{Al}(\text{NO}_3)_3$  solution.
- 7.3. Ascorbic acid (1.5M): Dissolve 66 g of ascorbic acid ( $\text{C}_6\text{H}_8\text{O}_6$ ) in 200 mL of water, warming gently to dissolve, and dilute to 250 mL with water. Shelf life is 30 days or less.
- 7.4. Cerium (III) nitrate hexahydrate ( $\text{Ce}(\text{NO}_3)_3 \cdot 6 \text{H}_2\text{O}$ )
  - 7.4.1. Cerium carrier, 0.5 mg Ce/mL: Dissolve 0.155 g cerium (III) nitrate hexahydrate in 50 mL water, and dilute to 100 mL with water.
- 7.5. Ethanol, 100%: Anhydrous  $\text{C}_2\text{H}_5\text{OH}$ , available commercially, or mix 95 mL 100% ethanol and 5 mL water.
- 7.6. Ferric nitrate solution (5 mg/mL): Dissolve 18.1 g of ferric nitrate ( $\text{Fe}(\text{NO}_3)_3 \cdot 9 \text{H}_2\text{O}$ ) in 300 mL water and dilute to 500 mL with water.
- 7.7. Hydrochloric acid (12M): Concentrated HCl, available commercially.
  - 7.7.1. Hydrochloric acid (0.1M) + Hydrofluoric acid (0.05M) solution: Add 1.8 mL concentrated HF and 8.3 mL concentrated HCl to 500 mL of water. Dilute to 1 L with water and mix well.
    - 7.7.1.1. Hydrochloric acid (0.1M) + Hydrofluoric acid (0.05M) +  $\text{TiCl}_3$  (0.01 M): Add 1 mL of 10 wt% solution  $\text{TiCl}_3$  per 100 mL of hydrochloric acid (0.1M) + hydrofluoric acid (0.05M) solution; prepare fresh daily as needed.
  - 7.7.2. Hydrochloric acid (9M): Add 750 mL of concentrated HCl to 100 mL of water and dilute to 1 L with water.
- 7.8. Hydrofluoric acid (28M): Concentrated HF, available commercially.
- 7.9. Hydrogen peroxide ( $\text{H}_2\text{O}_2$ ), 30%: Available commercially.
- 7.10. Nitric acid (16M): Concentrated  $\text{HNO}_3$ , available commercially.
  - 7.10.1. Nitric acid (3M): Add 191 mL of concentrated  $\text{HNO}_3$  to 700 mL of water and dilute to 1 L with water.
- 7.11. Plutonium-242 tracer solution: Add 15–25 dpm of  $^{242}\text{Pu}$  per aliquant. The tracer activity added and sample count time should be sufficient to obtain a combined standard uncertainty of less than 5% for the chemical yield measurement.
 

**NOTE: If it is suspected that  $^{242}\text{Pu}$  or  $^{237}\text{Np}$  may be present in the sample at levels significant to interfere,  $^{236}\text{Pu}$  tracer is an acceptable substitute. The  $^{242}\text{Pu}$  (4.90 MeV) tracer peak may overlap slightly with the alpha energy of  $^{237}\text{Np}$  (4.78 MeV).**
- 7.12. Sodium nitrite ( $\text{NaNO}_2$ ).
  - 7.12.1. Sodium nitrite solution, 3.5M ( $\text{NaNO}_2$ ): Dissolve 6.1 g of sodium nitrite in 25 mL of water. Prepare fresh daily.
- 7.13. Sulfamic acid ( $\text{H}_3\text{NSO}_3$ ).

- 7.13.1. Sulfamic acid solution, 1.5M ( $\text{H}_3\text{NSO}_3$ ): Dissolve 72.7 g of sulfamic acid in 400 mL of water and dilute to 500 mL with water.
  - 7.14. TEVA<sup>®</sup> Resin – 2 mL cartridge, 50 to 100  $\mu\text{m}$  mesh size, Eichrom part number TE-R50-S and TE-R200-S, or equivalent.
  - 7.15. Titanium (III) chloride solution ( $\text{TiCl}_3$ ): Dissolve 10 wt% solution in 20–30 wt% hydrochloric acid.
8. Sample Collection, Preservation, and Storage  
Not Applicable.
  9. Quality Control
    - 9.1. Batch quality control results shall be evaluated and meet applicable Analytical Protocol Specifications (APS) prior to release of unqualified data. In the absence of project-defined APS or a project specific quality assurance project plan (QAPP), the quality control sample acceptance criteria defined in the laboratory quality manual and procedures shall be used to determine acceptable performance for this method.
      - 9.1.1. A Laboratory Control Sample (LCS) shall be run with each batch of samples. The concentration of the LCS should be at or near the AAL or level of interest for the project.
      - 9.1.2. One method blank shall be run with each batch of samples. The laboratory blank should consist of an acceptable simulant or empty crucible blank processed through the fusion procedure (Reference 16.3).
      - 9.1.3. One laboratory duplicate shall be run with each batch of samples. The laboratory duplicate is prepared by removing an aliquant from the original sample container.
      - 9.1.4. A matrix spike sample may be included as a batch quality control sample if there is concern that matrix interferences may compromise chemical yield measurements or overall data quality. This is typically not required.
    - 9.2. The source preparation method should produce a sample test source with a tracer peak full width at half maximum (FWHM) of less than 0.1 MeV. Sample test sources may require redissolution and reprocessing through some or all of the chemical separation steps of the method if this range of FWHM cannot be achieved.
  10. Calibration and Standardization
    - 10.1. Set up the alpha spectrometry system according to the manufacturer's recommendations. The energy range of the spectrometry system should at least include the region between ~3.5 and 7 MeV.
    - 10.2. Calibrate each detector used to count samples according to ASTM Standard Practice D7282, Section 18, "Alpha Spectrometry Instrument Calibrations" (Reference 16.4).
    - 10.3. Continuing Instrument Quality Control Testing shall be performed according to ASTM Standard Practice D7282, Sections 20, 21, and 24 (Reference 16.4).

## 11. Procedure

### 11.1. Initial Sample Preparation for Plutonium

- 11.1.1. Pu isotopes may be preconcentrated from building material samples using the procedure *Rapid Method for Sodium Hydroxide Fusion of Concrete and Brick Matrices Prior to Americium, Plutonium, Strontium, Radium, and Uranium Analyses* (Reference 16.3), which fuses the samples using rapid NaOH fusion followed by iron hydroxide and lanthanum fluoride precipitation to preconcentrate Pu isotopes from the hydroxide matrix.<sup>6</sup>
- 11.1.2. This separation can be used with other sample matrices if the initial sample preparation steps result in a column load solution containing ~3M HNO<sub>3</sub>-1M Al(NO<sub>3</sub>)<sub>3</sub>.
- 11.1.3. A smaller volume of the total load solution may be taken and analyzed as needed for very high activity samples, with appropriate dilution factor calculations applied.

### 11.2. Rapid Plutonium Separation using TEVA<sup>®</sup> Resin

**NOTE:** <sup>237</sup>Np is separated along with Pu isotopes using this TEVA<sup>®</sup> Resin separation. <sup>236</sup>Pu has been used as a yield monitor so that <sup>237</sup>Np can be determined, but this was not tested as part of the method validation testing.

- 11.2.1. Perform valence adjustment on column load solutions prepared in *Rapid Method for Sodium Hydroxide Fusion of Concrete and Brick Matrices Prior to Americium, Plutonium, Strontium, Radium, and Uranium Analyses* (Reference 16.3).

- 11.2.1.1. If particles are observed suspended in the solution, centrifuge the sample, collect the supernatant solution in small beaker and discard the precipitate.

**NOTE:** If a smaller volume was taken instead of the total load solution, this smaller volume should be diluted to ~15 mL with 3M HNO<sub>3</sub> before proceeding with the valence adjustment. The amounts of valence adjustment reagents may be adjusted under certain conditions as needed, as long as adequate reduction to Pu<sup>+3</sup> and oxidation to Pu<sup>+4</sup> are achieved.

- 11.2.1.2. Add 0.5 mL of 1.5M sulfamic acid to each solution. Swirl to mix.

- 11.2.1.3. Add 0.2 mL of 5 mg/mL ferric nitrate solution.

**NOTE:** Ferric ions are added and are reduced to ferrous ions by ascorbic acid to enhance valence reduction of Pu isotopes.

- 11.2.1.4. Add 1.25 mL of 1.5M ascorbic acid to each solution, swirling to mix. Wait 3 minutes.

- 11.2.1.5. Add 1mL 3.5M NaNO<sub>2</sub> to each sample, swirling to mix.

**NOTE:** A small amount of brown fumes result from nitrite reaction with sulfamic acid. The solution should clear with swirling and not remain dark. If the solution does not clear (is still dark) an additional small volume of sodium nitrite may be added to clear the solution.

---

<sup>6</sup> The fusion procedure provides a column load solution for each sample (consisting of 5 mL 3M HNO<sub>3</sub>-0.25M H<sub>3</sub>BO<sub>3</sub>+ 6mL HNO<sub>3</sub>+7 mL 2M Al(NO<sub>3</sub>)<sub>3</sub> + 3mL 3M HNO<sub>3</sub>), ready for valence adjustment and column separation on TEVA resin.



11.2.2. Set up TEVA<sup>®</sup> cartridges on the vacuum box system

**NOTE: This section deals with a commercially available vacuum box system. Other vacuum systems developed by individual laboratories may be substituted here as long as the laboratory has provided guidance to analysts in their use. The cartridges may be set up and conditioned with nitric acid so that they are ready for column loading just prior to completion of the valence adjustment steps.**

- 11.2.2.1. Place the inner tube rack (supplied with vacuum box) into the vacuum box with the centrifuge tubes in the rack. Place the lid on the vacuum box system.
- 11.2.2.2. Place the yellow outer tips into all 24 openings of the lid of the vacuum box. Fit in the inner white tip into each yellow tip.
- 11.2.2.3. For each sample solution, fit in the TEVA<sup>®</sup> cartridge on to the inner white tip.
- 11.2.2.4. Place reservoirs on the top end of the TEVA<sup>®</sup> cartridge.
- 11.2.2.5. Turn the vacuum on (building vacuum or pump) and ensure proper fitting of the lid.

**IMPORTANT: The unused openings on the vacuum box must be sealed to have vacuum. Yellow caps (included with the vacuum box) can be used to plug unused white tips to achieve a good seal during the separation. Alternately, plastic tape can be used to seal the unused lid holes as needed.**

- 11.2.2.6. Add 5 mL of 3M HNO<sub>3</sub> to the column reservoir to precondition the TEVA<sup>®</sup> cartridges.
- 11.2.2.7. Adjust the vacuum to achieve a flow-rate of ~1 mL/min.

**IMPORTANT: Unless otherwise specified in the procedure, use a flow rate of ~1 mL/min for load and strip solutions and ~2 -4 mL/min for rinse solutions.**

11.2.3. TEVA<sup>®</sup> Resin Separation

- 11.2.3.1. Transfer each sample solution from step 11.2.1.5 into the appropriate reservoir. Allow solution to pass through the TEVA<sup>®</sup> cartridge at a flow rate of ~1 mL/min.
- 11.2.3.2. Add 3 mL of 3M HNO<sub>3</sub> to each beaker (from Step 11.2.1.4) as a rinse and transfer each solution into the appropriate reservoir (the flow rate can be adjusted to ~3 mL/min).
- 11.2.3.3. Add 10 mL of 3M HNO<sub>3</sub> into each reservoir to rinse column (flow rate ~3–4 mL/min).
- 11.2.3.4. Turn off vacuum and discard rinse solutions.
- 11.2.3.5. Add 10 mL of 3M HNO<sub>3</sub> into each reservoir to rinse column (flow rate ~3–4 mL/min).
- 11.2.3.6. Add 20 mL of 9M HCl into each reservoir to remove any Th isotopes present (flow rate ~2–3 mL/min).
- 11.2.3.7. Add ~3 mL of 3M HNO<sub>3</sub> into each reservoir to reduce bleed-off of organic extraction during Pu strip step (flow rate ~3 mL/min).

**NOTE: The 3M HNO<sub>3</sub> added reduces extractant bleedoff that can occur with strong HCl and may improve alpha peak resolution.**

- 11.2.3.8. Turn off vacuum and discard rinse solutions.

11.2.3.9. Ensure that clean, labeled plastic 50-mL centrifuge tubes are placed in the tube rack under each cartridge.

**NOTE: For maximum removal of interferences during elution, also change reservoirs and connector tips prior to Pu elution.**

11.2.3.10. Add 20 mL of 0.1M HCL-0.05M HF-0.01M  $TiCl_3$  solution to elute plutonium from each cartridge, reducing the flow rate to ~1–2 mL/min.

11.2.3.11. Set plutonium fraction in the plastic centrifuge tube aside for cerium fluoride coprecipitation, Step 11.3.

11.2.3.12. Discard the TEVA<sup>®</sup> cartridge.

### 11.3. Preparation of the Sample Test Source

**NOTE: Instructions below describe preparation of a single Sample Test Source. Several sample test sources can be prepared simultaneously if a multi-channel vacuum manifold system is available.**

11.3.1. Pipet 100  $\mu$ L of the cerium carrier solution (0.5 mg Ce/mL) into each centrifuge tube.

11.3.2. Pipet 0.5 mL 30 wt%  $H_2O_2$  into each tube to prevent any residual uranium ions from precipitating.

11.3.3. Pipet 1 mL of concentrated HF into each tube.

11.3.4. Cap the tube and mix. Allow solutions sit for ~15 minutes before filtering.

11.3.5. Set up a filter apparatus to accommodate a 0.1 micron, 25 mm membrane filter on a microprecipitation filtering apparatus.

**Caution: There is no visible difference between the two sides of the filter. If the filter is turned over accidentally, discard the filter and remove a fresh one from the box.**

11.3.6. Add a few drops of 95% ethanol to wet each filter and apply vacuum. Ensure that there are no leaks along the sides before proceeding.

11.3.7. While vacuum applied, add 2–3 mL of filtered Type I water to each filter and allow the liquid to drain.

11.3.8. Add the sample to the filter reservoir, rinsing the sample tubes with ~3 mL of water and transfer this rinse to filter apparatus. Allow to drain.

11.3.9. Wash each filter with ~2–3 mL of water and allow to drain.

11.3.10. Wash each filter with ~1–2 mL of 95% ethanol to displace water.

11.3.11. Allow to drain completely before turning the vacuum off.

11.3.12. Mount the filter on a labeled adhesive mounting disk (or equivalent) ensuring that the filter is not wrinkled and is centered on mounting disk.

11.3.13. Place the filter under a heat lamp for 3 to 5 minutes or more until it is completely dry. Do not overheat.

11.3.14. Count filters for an appropriate period of time by alpha spectrometry.

11.3.15. Discard the filtrate to waste for future disposal. If the filtrate is to be retained, it should be placed in a plastic container to avoid dissolution of the glass vessel by dilute HF.

**NOTE: Other methods for sample test source preparation, such as microprecipitation with neodymium fluoride (NdF<sub>3</sub>), may be used in lieu of the cerium fluoride microprecipitation, but any such substitution must be validated as described in Section 1.5. Nd is typically interchangeable with Ce.**

## 12. Data Analysis and Calculations

12.1. Equations for determination of final result, combined standard uncertainty and radiochemical yield (if required):

The activity concentration of an analyte and its combined standard uncertainty are calculated using the following equations:

$$AC_a = \frac{A_t \times R_a \times D_t \times I_t}{W_a \times R_t \times D_a \times I_a} \quad (1)$$

and

$$u_c(AC_a) = \sqrt{u^2(R_a) \times \frac{A_t^2 \times D_t^2 \times I_t^2}{W_a^2 \times R_t^2 \times D_a^2 \times I_a^2} + AC_a^2 \times \left( \frac{u^2(A_t)}{A_t^2} + \frac{u^2(W_a)}{W_a^2} + \frac{u^2(R_t)}{R_t^2} \right)} \quad (2)$$

where:

- $AC_a$  = activity concentration of the analyte at time of count, in picocuries per gram (pCi/g)
- $A_t$  = activity of the tracer added to the sample aliquant at its reference date/time (pCi)
- $R_a$  = net count rate of the analyte in the defined region of interest (ROI), in counts per second
- $R_t$  = net count rate of the tracer in the defined ROI, in counts per second
- $W_a$  = weight of the sample aliquant (g)
- $D_t$  = correction factor for decay of the tracer from its reference date and time to the midpoint of the counting period
- $D_a$  = correction factor for decay of the analyte from the time of sample collection (or other reference time) to the midpoint of the counting period (if required)
- $I_t$  = probability of  $\alpha$  emission in the defined ROI per decay of the tracer (Table 17.1)
- $I_a$  = probability of  $\alpha$  emission in the defined ROI per decay of the analyte (Table 17.1)
- $u_c(AC_a)$  = combined standard uncertainty of the activity concentration of the analyte (pCi/L)
- $u(A_t)$  = standard uncertainty of the activity of the tracer added to the sample (pCi)
- $u(R_a)$  = standard uncertainty of the net count rate of the analyte (s<sup>-1</sup>)

$u(R_t)$  = standard uncertainty of the net count rate of the tracer ( $s^{-1}$ )  
 $u(W_a)$  = standard uncertainty of the weight of sample aliquant (g)

**NOTE: The uncertainties of the decay-correction factors and of the probability of decay factors are assumed to be negligible.**

**NOTE: The equation for the combined standard uncertainty ( $u_c(AC_a)$ ) calculation is arranged to eliminate the possibility of dividing by zero if  $R_a = 0$ .**

**NOTE: The standard uncertainty of the activity of the tracer added to the sample shall be calculated by propagating the standard uncertainty associated with the activity of the standard reference material and any other significant sources of uncertainty such as those introduced during the preparation of the tracer solution (e.g., weighing or dilution factors) and during the process of adding the tracer to the sample.**

12.1.1. The net count rate of an analyte or tracer and its standard uncertainty are calculated using the following equations:

$$R_x = \frac{C_x}{t_s} - \frac{C_{bx}}{t_b} \quad (3)$$

and

$$u(R_x) = \sqrt{\frac{C_x + 1}{t_s^2} + \frac{C_{bx} + 1}{t_b^2}} \quad (4)$$

where:

$R_x$  = net count rate of analyte or tracer, in counts per second  
 $C_x$  = sample counts in the analyte or the tracer ROI  
 $t_s$  = sample count time (s)  
 $C_{bx}$  = background counts in the same ROI as for x  
 $t_b$  = background count time (s)  
 $u(R_x)$  = standard uncertainty of the net count rate of tracer or analyte, in counts per second<sup>7</sup>

If the radiochemical yield of the tracer is requested, the yield and its combined standard uncertainty can be calculated using the following equations:

$$RY = \frac{R_t}{0.037 \times A_t \times D_t \times I_t \times \varepsilon} \quad (5)$$

and

<sup>7</sup> For methods with very low counts, MARLAP Section 19.5.2.2 recommends adding one count each to the gross counts and the background counts when estimating the uncertainty of the respective net counts. This approach minimizes negative bias in the estimate of uncertainty and protects against calculating zero uncertainty when a total of zero counts are observed for the sample and background.

$$u_c(RY) = RY \times \sqrt{\frac{u^2(R_t)}{R_t^2} + \frac{u^2(A_t)}{A_t^2} + \frac{u^2(\varepsilon)}{\varepsilon^2}} \quad (6)$$

where:

$RY$	=	radiochemical yield of the tracer, expressed as a fraction
$R_t$	=	net count rate of the tracer, in counts per second
$A_t$	=	activity of the tracer added to the sample (pCi)
$D_t$	=	correction factor for decay of the tracer from its reference date and time to the midpoint of the counting period
$I_t$	=	probability of $\alpha$ emission in the defined ROI per decay of the tracer (Table 17.1)
$\varepsilon$	=	detector efficiency, expressed as a fraction
$u_c(RY)$	=	combined standard uncertainty of the radiochemical yield
$u(R_t)$	=	standard uncertainty of the net count rate of the tracer, in counts per second
$u(A_t)$	=	standard uncertainty of the activity of the tracer added to the sample (pCi)
$u(\varepsilon)$	=	standard uncertainty of the detector efficiency

12.1.2. If the critical level concentration ( $L_c$ ) or the minimum detectable concentration (MDC) are requested (at an error rate of 5%), they can be calculated using the following equations:<sup>8</sup>

$$L_c = \frac{\left[ 0.4 \times \left( \frac{t_s}{t_b} - 1 \right) + 0.677 \times \left( 1 + \frac{t_s}{t_b} \right) + 1.645 \times \sqrt{\left( R_{ba} t_b + 0.4 \right) \times \frac{t_s}{t_b} \times \left( 1 + \frac{t_s}{t_b} \right)} \right] \times A_t \times D_t \times I_t}{t_s \times W_a \times R_t \times D_a \times I_a} \quad (7)$$

$$MDC = \frac{\left[ 2.71 \times \left( 1 + \frac{t_s}{t_b} \right) + 3.29 \times \sqrt{R_{ba} t_s \times \left( 1 + \frac{t_s}{t_b} \right)} \right] \times A_t \times D_t \times I_t}{t_s \times W_a \times R_t \times D_a \times I_a} \quad (8)$$

where:

<sup>8</sup> The formulations for the critical level and minimum detectable concentrations are based on the Stapleton Approximation as recommended in MARLAP Section 20A.2.2, Equations 20.54 and 20A.3.2, and Equation 20.74, respectively. The formulations presented here assume an error rate of  $\alpha = 0.05$ ,  $\beta = 0.05$  (with  $z_{1-\alpha} = z_{1-\beta} = 1.645$ ) and  $d = 0.4$ , a constant in equation 20.54 (the z value of 1.645 reflects the 1- $\alpha$  and 1- $\beta$  quantiles of the normal distribution when  $\alpha = \beta = 0.05$ ). For methods with very low numbers of counts, these expressions provide better estimates than do the traditional formulas for the critical level and MDC.

$R_{ba}$  = background count rate for the analyte in the defined ROI, in counts per second

## 12.2. Results Reporting

12.2.1. The following data should be reported for each result: volume of sample used; yield of tracer and its uncertainty; and FWHM of each peak used in the analysis.

12.2.2. The following conventions should be used for each result:

12.2.2.1. Result in scientific notation  $\pm$  combined standard uncertainty.

## 13. Method Performance

13.1. Method validation results are to be reported.

13.2. Expected turnaround time per batch of 14 samples plus quality control, assuming microprecipitations for the whole batch are performed simultaneously using a vacuum box system:

13.2.1. For an analysis of a 1 g sample aliquant, sample preparation and digestion should take ~3 h.

13.2.2. Purification and separation of the plutonium fraction using cartridges and vacuum box system should take ~2.25 h.

13.2.3. The sample test source preparation step takes ~1 h.

13.2.4. A one-hour counting time should be sufficient to meet the MQOs listed in 1.5, assuming detector efficiency of 0.2–0.3, and radiochemical yield of at least 0.5. A different counting time may be necessary to meet these MQOs if any of the relevant parameters are significantly different.

13.2.5. Data should be ready for reduction ~7.25 h after beginning of analysis, depending on the MQOs. In order to meet the MQOs for the method validation process, a counting time of four hours was required.

14. Pollution Prevention: The method utilizes small volume (2 mL) extraction chromatographic resin columns. This approach leads to a significant reduction in the volumes of load, rinse and strip solutions, as compared to classical methods using ion exchange resins to separate and purify the plutonium fraction.

## 15. Waste Management

15.1. Types of waste generated per sample analyzed

15.1.1. Approximately 65 mL of acidic waste from loading and rinsing the extraction column will be generated. These solutions may contain an unknown quantity of radionuclides such as Am, U, and Th isotopes if present in the sample originally.

15.1.2. Approximately 45 mL of acidic waste from the microprecipitation method for source preparation will be generated. The waste contains 1 mL of HF and ~5 mL of ethanol.

- 15.1.3. TEVA<sup>®</sup> cartridge – ready for appropriate disposal. Used resins and columns should be considered radioactive waste and disposed of in accordance with restriction provided in the facility’s radioactive materials license and any prevailing government restrictions.
- 15.2. Evaluate waste streams according to disposal requirements by applicable regulations.

## 16. References

### *Cited References*

- 16.1. U.S. Environmental Protection Agency (EPA). 2009. *Method Validation Guide for Radiological Laboratories Participating in Incident Response Activities*. Revision 0. Office of Air and Radiation, Washington, DC. EPA 402-R-09-006, June. Available at: [www.epa.gov/narel/incident\\_guides.html](http://www.epa.gov/narel/incident_guides.html).
- 16.2. *Multi-Agency Radiological Laboratory Analytical Protocols Manual (MARLAP)*. 2004. EPA 402-B-04-001A, July. Volume I, Chapters 6, 7, 20, Glossary; Volume II and Volume III, Appendix G. Available at: [www.epa.gov/radiation/marlap/index.html](http://www.epa.gov/radiation/marlap/index.html).
- 16.3. U.S. Environmental Protection Agency (EPA). 2014. *Rapid Method for Sodium Hydroxide Fusion of Concrete and Brick Matrices Prior to Americium, Plutonium, Strontium, Radium, and Uranium Analyses*. Revision 0, EPA 402-R-14-004. Office of Air and Radiation, Washington, DC. Available at: [www.epa.gov/narel](http://www.epa.gov/narel).
- 16.4. ASTM D7282 “Standard Practice for Set-up, Calibration, and Quality Control of Instruments Used for Radioactivity Measurements,” ASTM Book of Standards 11.02, current version, ASTM International, West Conshohocken, PA.
- 16.5. ASTM D1193, “Standard Specification for Reagent Water,” ASTM Book of Standards 11.02, current version, ASTM International, West Conshohocken, PA.
- 16.6. U.S. Environmental Protection Agency (EPA). 2014. Rapid Radiochemical Method for Americium-241 in Building Materials for Environmental Remediation Following Radiological Incidents. Revision 0, EPA 402-R-14-007. Office of Air and Radiation, Washington, DC. Available at: [www.epa.gov/narel](http://www.epa.gov/narel).
- 16.7. U.S. Environmental Protection Agency (EPA). 2014. Rapid Radiochemical Method for Pu-238 and Pu-239/240 in Building Materials for Environmental Remediation Following Radiological Incidents. Revision 0, EPA 402-R-14-006. Office of Air and Radiation, Washington, DC. Available at: [www.epa.gov/narel](http://www.epa.gov/narel).
- 16.8. U.S. Environmental Protection Agency (EPA). 2014. Rapid Radiochemical Method for Radium-226 in Building Materials for Environmental Remediation Following Radiological Incidents. Revision 0, EPA 402-R-14-002. Office of Air and Radiation, Washington, DC. Available at: [www.epa.gov/narel](http://www.epa.gov/narel).
- 16.9. U.S. Environmental Protection Agency (EPA). 2014. Rapid Radiochemical Method for Total Radiostrontium (Sr-90) in Building Materials for Environmental Remediation Following Radiological Incidents. Revision 0, EPA 402-R-14-001. Office of Air and Radiation, Washington, DC. Available at: [www.epa.gov/narel](http://www.epa.gov/narel).

- 16.10. U.S. Environmental Protection Agency (EPA). 2014. Rapid Radiochemical Method for Isotopic Uranium in Building Materials for Environmental Remediation Following Radiological Incidents. Revision 0, EPA 402-R-14-005. Office of Air and Radiation, Washington, DC. Available at: [www.epa.gov/narel](http://www.epa.gov/narel).

*Other References*

- 16.11. Maxwell, S., Culligan, B. and Noyes, G. 2010. Rapid method for actinides in emergency soil samples, *Radiochimica Acta*. 98(12): 793-800.
- 16.12. Maxwell, S., Culligan, B., Kelsey-Wall, A. and Shaw, P. 2011. "Rapid Radiochemical Method for Actinides in Emergency Concrete and Brick Samples," *Analytica Chimica Acta*. 701(1): 112-8.
- 16.13. VBS01, Rev.1.3, "Setup and Operation Instructions for Eichrom's Vacuum Box System (VBS)," Eichrom Technologies, Inc., Lisle, Illinois (January 2004).

17. Tables, Diagrams, Flow Charts, and Validation Data

17.1. Tables

**Table 17.1 Alpha Particle Energies and Abundances of Importance<sup>[1]</sup>**

Nuclide	Half-Life (Years)	$\lambda$ (s <sup>-1</sup> )	Emission Probability (Abundance) <sup>[2]</sup>	$\alpha$ Energy (MeV)
<sup>238</sup> Pu	87.7	2.50×10 <sup>-10</sup>	0.7091	5.499
			0.2898	5.456
<sup>239/240</sup> Pu (Total) <sup>[3]</sup>	2.411×10 <sup>4</sup>	9.110×10 <sup>-13</sup>	0.9986	(All at same peak)
<sup>239</sup> Pu	2.411×10 <sup>4</sup>	9.110×10 <sup>-13</sup>	0.7077	5.157
			0.1711	5.144
			0.1194	5.105
<sup>240</sup> Pu	6.561×10 <sup>3</sup>	3.348×10 <sup>-12</sup>	0.7280	5.168
			0.2710	5.124
<sup>242</sup> Pu	3.735×10 <sup>5</sup>	5.881×10 <sup>-14</sup>	0.7649	4.902
			0.2348	4.858

[1] Only the most abundant particle energies and abundances have been noted here.

[2] Unless individual plutonium isotopes are present, the alpha emissions for <sup>239/240</sup>Pu or separately for <sup>238</sup>Pu, should use an abundance factor of 1.0.

[3] Half-life and  $\lambda$  are based on <sup>239</sup>Pu.

17.2. Ingrowth Curves and Ingrowth Factors

*This section intentionally left blank  
(In-growth is not applicable to the method)*



17.3. Spectrum from a Processed Sample

**Plutonium Spectrum**

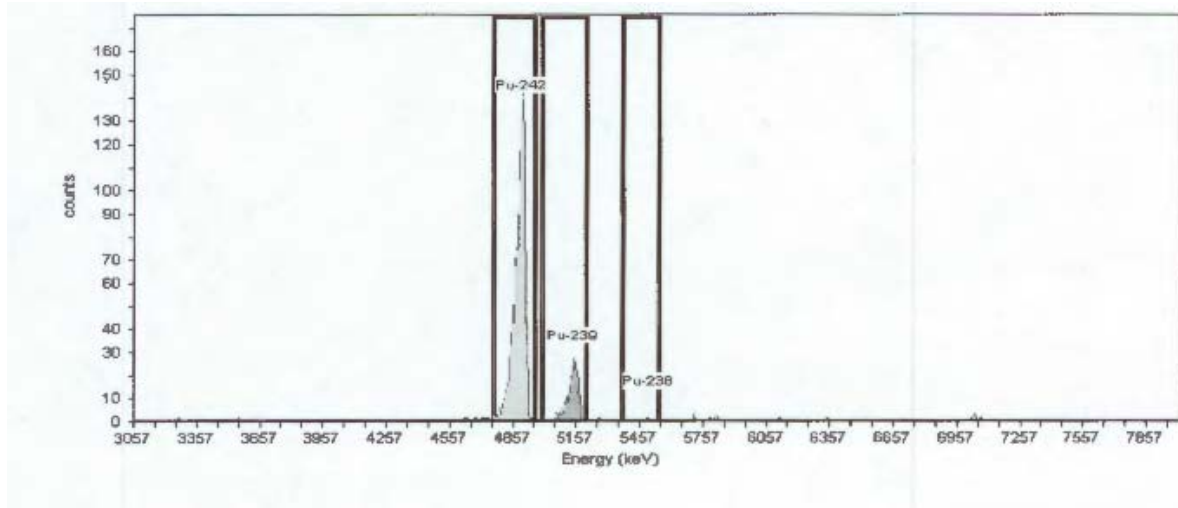

17.4. Decay Scheme

**Plutonium Decay Scheme**

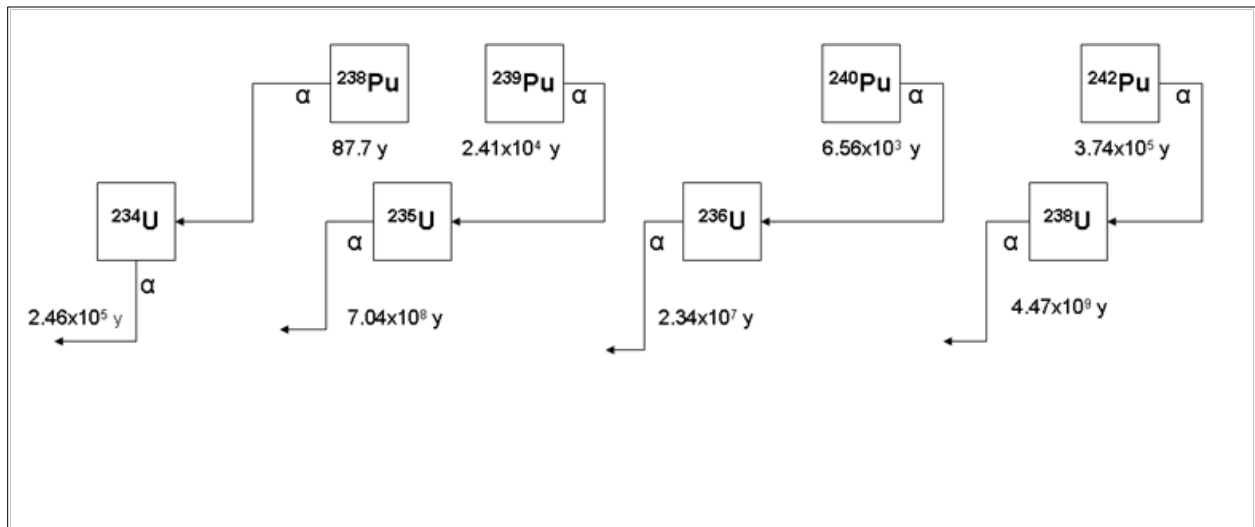

17.5. Flow chart

**Separation Scheme and Timeline for Determination of Pu Isotopes in Building Materials Samples**

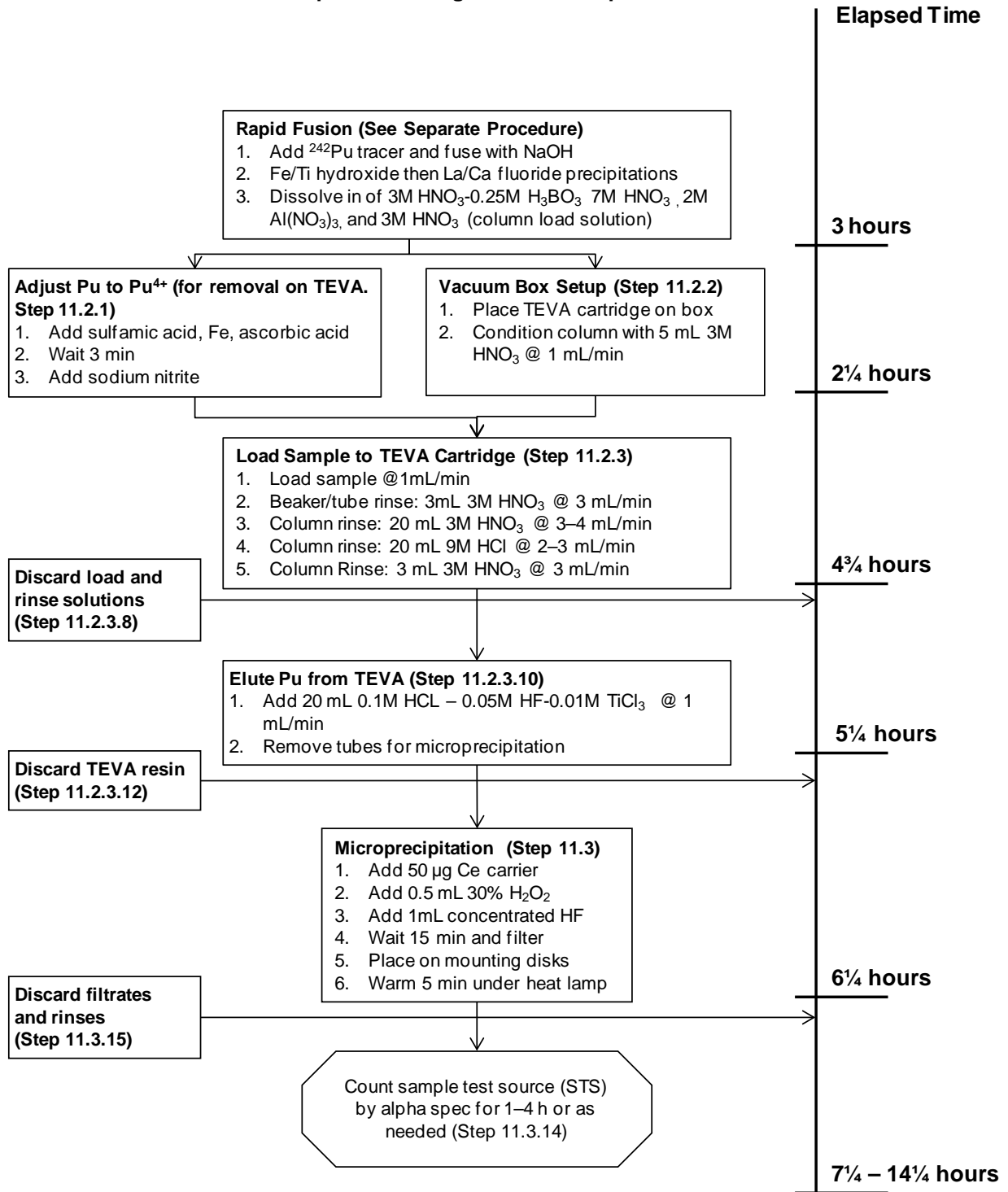

**Appendix:**

**Example of Sequential Separation Using Am-241, Pu-238+Pu-239/240, and Isotopic U in Building Materials**

This sequential combination of rapid procedures for Am-241, Pu-238+Pu-239/240, and isotopic U in building materials (References 16.6, 16.7, and 16.10) has been used by some laboratories, but this sequential approach was not included in this method validation.

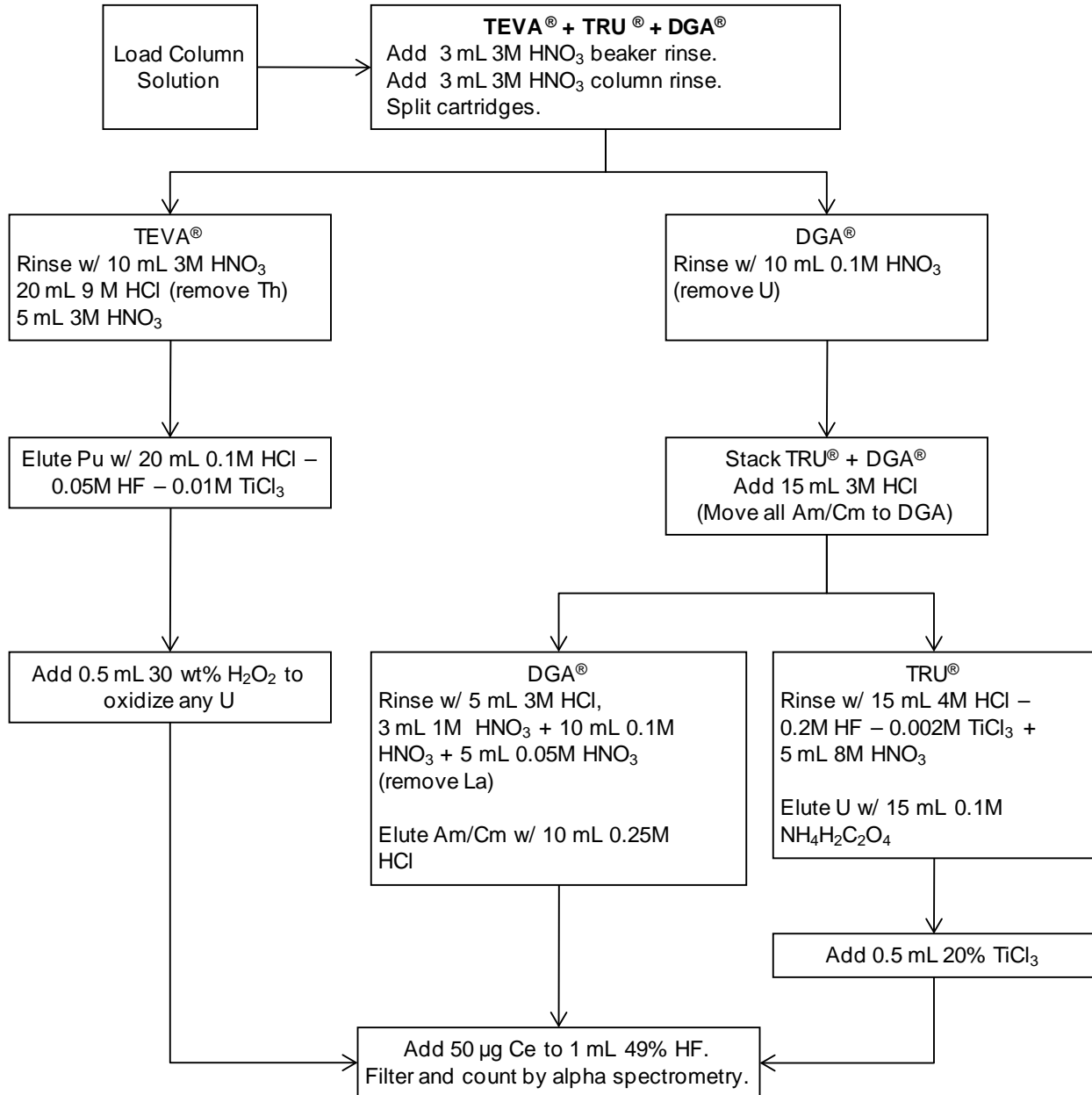

**Attachment IV:****Composition of Brick Used for Spiking in this Study**

<b>Metals by ICP-AES</b> <sup>[4]</sup>	<b>Concentration (ppm)</b> <sup>[1]</sup>
Silicon Dioxide	721,700
Aluminum	78,700
Barium	400
Calcium	1,600
Iron	40,000
Magnesium	4,600
Potassium	15,300
Sodium	1,500
Titanium	4,400
Manganese	600
Strontium	100
Uranium	<30
Thorium	<30
<b>Non-Metals</b>	
Chloride	—
Sulfur	5,600
Phosphorus	1,500
<b>Radionuclide</b>	<b>Concentration (pCi/g)</b> <sup>[2, 3]</sup>
Uranium 238, 234	1.054 ± 0.020, 1.102 ± 0.021
Plutonium 239/240	-0.0003 ± 0.0041
Americium 241	0.048 ± 0.039
Strontium 90	0.119 ± 0.077
Radium 226	1.025 ± 0.027

NOTE: Wyoming Analytical Laboratories, Inc. of Golden, Colorado, performed the macro analysis.

- [1] Values below the reporting level are presented as less than (<) values. No measurement uncertainty was reported with the elemental analysis values. Parts per million (ppm).
- [2] Reported values represent the average value of seven blank samples analyzed except for <sup>226</sup>Ra and U by NAREL. Ten blank brick samples were analyzed for <sup>226</sup>Ra. Sixteen blank brick samples were analyzed for the uranium isotopes.
- [3] Reported uncertainty is the standard deviation of the results ( $k=1$ ).
- [4] ICP-AES=Inductively Coupled Plasma – Atomic Emission Spectrometry