

United States
Environmental
Protection Agency

Office of Ground Water
and Drinking Water (4601) September 1999

EPA/816-R-99-014v



The Class V Underground Injection Control Study

Volume 22

Noncontact Cooling Water Wells

Table of Contents

	Page
1. Summary	1
2. Introduction	2
3. Prevalence of Wells	3
4. Wastewater Characteristics And Injection Practices	6
4.1 Injectate Characteristics	6
4.1.1 Discharge Monitoring Report from New Jersey	8
4.1.2 Toxicity Characterization Study from Massachusetts and New Hampshire	9
4.2 Well Characteristics	9
4.3 Operational Practices	10
5. Potential And Documented Damage to USDWs	12
6. Best Management Practices	12
7. Current Regulatory Requirements	12
7.1 Federal Programs	12
7.1.1 SDWA	12
7.1.2 CWA	13
7.2 State and Local Programs	14
Attachment A: State and Local Program Descriptions	15
References	22

NONCONTACT COOLING WATER WELLS

The U.S. Environmental Protection Agency (USEPA) conducted a study of Class V underground injection wells to develop background information the Agency can use to evaluate the risk that these wells pose to underground sources of drinking water (USDWs) and to determine whether additional federal regulation is warranted. The final report for this study, which is called the Class V Underground Injection Control (UIC) Study, consists of 23 volumes and five supporting appendices. Volume 1 provides an overview of the study methods, the USEPA UIC Program, and general findings. Volumes 2 through 23 present information summaries for each of the 23 categories of wells that were studied (Volume 21 covers 2 well categories). This volume, which is Volume 22, covers Class V wells that inject noncontact cooling water.

1. SUMMARY

For the purpose of this study, “noncontact cooling water wells” are limited only to wells used to inject noncontact cooling water that contains no additives and has not been chemically altered. Wells that inject contact cooling water or noncontact cooling water that contains additives (e.g., corrosion inhibitors, biocides) or is contaminated compared to the original source water are considered “industrial wells.”

USEPA defines noncontact cooling water (in 40 CFR §418.21 governing fertilizer manufacturing) as “water which is used in a cooling system designed so as to maintain constant separation of the cooling medium from all contact with process chemicals...provided, that all reasonable measures have been taken to prevent, reduce, eliminate and control to the maximum extent feasible...contamination...” No sampling data were obtained during the course of this study that can be used to characterize the quality of fluids injected into noncontact cooling water wells. However, given the very narrow way that such wells and noncontact cooling water are defined, it is reasonable to expect that the quality of the fluids will not threaten USDWs.

Available information suggests that these wells are commonly used in situations in which cooling water is withdrawn from an aquifer and then injected back into the same formation (so-called “cooling water return flow wells” as defined in 40 CFR §146.5(e)(3)). In these situations, the quality of the fluids injected will be the same as the quality of the fluids in the receiving formation, except for a change in temperature.

No contamination incidents associated with noncontact cooling water wells, as defined for the purpose of this study, have been reported. The only scenario in which noncontact cooling water wells could be contaminated would involve pipe leaks that allow process chemicals or other contaminants to commingle with the cooling water. Illicit discharges into these wells appear extremely unlikely, since noncontact cooling water systems are operated as closed systems that are virtually inaccessible for “midnight dumping.” No incidents of this or any other kind were uncovered during the course of this study.

As for some of the other well categories addressed in this study, the inventory results for noncontact cooling water wells are very uncertain because most responses to the state and USEPA Regional survey did not distinguish these wells from other kinds of commercial or industrial wells. The survey results suggest that there are more than 7,780 noncontact cooling water wells in the nation, but this number includes some carwash wells, laundromat wells, and food processing waste disposal wells. The survey results also indicate that noncontact cooling water wells may exist in as many as 22 states, although most appear to be concentrated in Alaska (212), Washington (3,900), and Tennessee (1,000). Ninety-eight percent of the documented and estimated noncontact cooling water wells in the U.S. are found in ten states: Alabama, Alaska, California, Iowa, Montana, New York, Ohio, Tennessee, West Virginia, and Washington.

Of the three states that have the vast majority of noncontact cooling water wells, Alaska and Washington require the wells to be individually permitted. Tennessee currently permits them by rule, following a program like the minimum federal requirements established in USEPA's existing UIC regulations.

2. INTRODUCTION

Industries use water to cool processes, products, or equipment. Water is an ideal heat sink, due to its low specific heat. The cooling water used in industrial heat exchange systems may originate from surface water, such as lakes or rivers, or from ground water. After ground water has been used for cooling, it may be returned to the subsurface through injection wells. There are advantages to the injection of the cooling water. For example, widespread pumping can decrease ground water levels in an aquifer and/or cause land subsidence, but injection may help preserve and protect an aquifer by returning water that meets drinking water standards to the voids in water-bearing strata (Snyder and Lee, 1980).

On July 29, 1998 (63 FR 40586), USEPA proposed revisions to the Class V UIC regulations that would add new requirements for the following three types of wells that, based on available information, were believed to pose a high risk to USDWs when located in ground water-based source water protection areas: motor vehicle waste disposal wells, industrial wells, and large-capacity cesspools. Under the consent decree described in Volume 1 of the study, all other types of Class V wells are to be studied further to determine whether they warrant additional UIC regulation.

In the July 29, 1998 proposal, "wells used to inject noncontact cooling water that contains no additives and has not been chemically altered" were included in the proposed "other industrial" well category.¹ In contrast, Class V wells used to inject contact cooling water or

¹ The wells in the proposed "other industrial well" category are: (1) wells used to inject fluids from carwashes that are not specifically set up to perform engine or undercarriage washing; (2) wells used to inject noncontact cooling water that contains no additives and has not been chemically altered; (3) wells used to inject fluids from laundromats where no onsite dry cleaning is performed or where no organic solvents are used for laundering; and (4) wells used to inject wastewater from food processing operations. The other three kinds of wells included in the other industrial well category are addressed in separate
(continued...)

noncontact cooling water that contains additives or has been chemically altered would fall into the industrial well category subject to the proposed regulation. Consistent with this proposed distinction, this study focuses primarily on noncontact cooling water wells (NCWWs) that contain no additives. However, it also examines other kinds of noncontact cooling water because available information does not always clearly distinguish between noncontact cooling water with additives and noncontact cooling water without additives.

3. PREVALENCE OF WELLS

For this study, data on the number of Class V NCWWs were collected through a survey of state and USEPA Regional UIC Programs. The survey methods are summarized in Section 4 of Volume 1 of the Class V Study. Table 1 lists the numbers of Class V NCWWs in each state, as determined from this survey. The table includes the documented number and estimated number of wells in each state, along with the source and basis for any estimate, when noted by the survey respondents. If a state is not listed in Table 1, it means that the UIC Program responsible for that state indicated in its survey response that it did not have any Class V NCWWs.

Some states and USEPA Regions administering the UIC program acknowledge that they have not been able to determine exactly how many NCWWs exist for a variety of reasons. Chief among these reasons is that NCWWs are sometimes grouped together with other well types in inventory databases. Thus, the state officials are unable to distinguish between NCWWs and other well types, such as heat pump/air conditioning (HAC) return flow wells, carwash wells, and other industrial wells, within their databases.

These uncertainties notwithstanding, Table 1 shows there are a total of 5,775 documented NCWWs and more than 7,780 estimated NCWWs in the U.S. The following ten states contain 98% of the documented and estimated NCWWs: Alabama, Alaska, California, Iowa, Montana, New York, Ohio, Tennessee, Washington, and West Virginia. The wells appear to be concentrated in Washington, Tennessee, and Alaska, but inventories from Washington and Tennessee may be incorrect. Tennessee officials believe they have included closed-loop HAC wells in their inventory (Sorrells, 1999), and Washington officials cannot differentiate between NCWWs and carwash wells within their inventory (Cadmus, 1999). Alaska has 212 documented wells; however, most of these wells are located at one facility and are being phased out and closed. In states where NCWWs are grouped in with other industrial wells, such as New York and West Virginia, the documented number is recorded as less than the total number of documented "other industrial" wells.

¹ (...continued)
volumes of the Class V Study.

Table 1. Inventory of Noncontact Cooling Water Wells in the U.S.

State	Documented Number of Wells	Estimated Number of Wells	
		Number	Source of Estimate and Methodology ¹
USEPA Region 1			
MA	NR	NR	Best professional judgement. State staff suspect that noncontact cooling water wells exist at some industrial facilities.
ME	0	NR	Suspects these wells exist in ME, but none are documented.
NH	14	>14	More wells suspected.
RI	4	Unknown	Best professional judgement.
USEPA Region 2			
NY	<174	1500	Best professional judgement, based on years of inspections and reviews of business directories.
USEPA Region 3			
MD	3	>3	More wells suspected, but no information provided.
WV	<223	>223 total other industrial wells	Best professional judgement.
USEPA Region 4			
AL	162 total wells, not categorized by type	>162	Best professional judgement.
FL	Unknown	NR	Based on field visits, believe wells exist, but no statewide inventory is available.
GA	2	2	N/A
TN	1000	>1000	State staff believe this number may include HAC return flow wells. Only five NCWWs may actually exist.
USEPA Region 5			
IL	0	>0	Best professional judgement.
IN	Unknown	Unknown	State staff did not provide estimate because it does not differentiate between industrial wells addressed in the July 29, 1998 proposed rulemaking and "other industrial wells."
MI	5	5	N/A
OH	8	60	Best professional judgement. Ohio's USEPA UIC inventory does not differentiate between industrial wells addressed or not addressed in the July 29, 1998 proposed rulemaking. Insufficient information on business locations and related sewer locations across the state to develop an accurate estimate.

**Table 1. Inventory of Noncontact Cooling Water Wells in the U.S.
(Continued)**

State	Documented Number of Wells	Estimated Number of Wells	
		Number	Source of Estimate and Methodology ¹
WI	0	NR	Suspect these wells exist in WI, based on inventory efforts made in some counties and best professional judgement.
USEPA Region 6 -- None			
USEPA Region 7			
IA	Unknown	<100	Best professional judgement. The estimate is based on discussions with trade organizations and county sanitarians, and from working with the regulated community.
KS	5	5	Best professional judgement.
MO	Unknown	Unknown	N/A
NE	14	14	N/A
USEPA Region 8			
MT	10	50	Best professional judgement.
ND	0	Very few	Best professional judgement.
SD	0	Unknown	Region suspects more wells exist in SD, but none are documented.
UT	7	>7	Best professional judgement.
WY	Unknown	Unknown	N/A
USEPA Region 9			
CA	7	507	Best professional judgement.
HI	5	5	N/A
NV	2	1-5	Best professional judgement.
USEPA Region 10			
AK	212	150	Best professional judgement. Most wells are located at one facility where they are being phased out.
ID	18	18	N/A
OR	0	50	Best professional judgement.
WA	3900	>3900	Includes both noncontact cooling water wells and carwash wells since database cannot distinguish between the two; suspects more wells exist in WA than documented.

**Table 1. Inventory of Noncontact Cooling Water Wells in the U.S.
(Continued)**

State	Documented Number of Wells	Estimated Number of Wells	
		Number	Source of Estimate and Methodology ¹
All USEPA Regions			
All States	<5,775	> 7,780	Both documented and estimated figures may include up to 3,900 car wash wells (see Washington) and up to 1,000 heat pump/AC wells (see Tennessee). Total estimated number counts the documented number when the estimate is NR.

¹ Unless otherwise noted, the best professional judgement is that of the state or USEPA Regional staff completing the survey questionnaire.

N/A Not available.

NR Although USEPA Regional, state and/or Territorial officials reported the presence of the well type, the number of wells was not reported, or the questionnaire was not returned.

Unknown Questionnaire completed, but number of wells is unknown.

4. WASTEWATER CHARACTERISTICS AND INJECTION PRACTICES

4.1 Injectate Characteristics

Within the scope of this study, noncontact cooling water contains no additives and has not been chemically altered. If no additives are introduced to the water during the cooling process, the injectate quality resembles the quality of the original source water used for cooling. Therefore, in situations where cooling water is withdrawn from an aquifer and then injected back into the same formation, the injectate quality will basically be the same as the water in the receiving formation. Theoretically, the only characteristic that will have changed would be the temperature.

Sometimes industries use additives in cooling water treatment programs in order to provide corrosion control, scaling control, fouling control, and microbiological control (Frayne, 1992). Additionally, the natural chemistry and increased temperature of the water sometimes accelerate corrosion of the pipes, introducing metallic elements to the injectate.

These additives may include a wide variety of chemicals in low levels. Examples include chlorine, zinc, and chromium in biocides, such as algacides, bactericides, and fungicides; well/pipe cleaners; sodium citrate in anti-scaling additives; antifreeze; and corroded pipe metal/scale and anti-corrosion additives (Bose, 1997). State officials have mentioned other examples, such as biodegradable additives, potassium permanganate for removing iron accumulation, acids for removing lime scale from pipes, and tiny amounts of glue used in gluing PVC pipes together (Sorrells, 1999).

USEPA Region 9 officials report some injectate quality information for noncontact cooling water wells in Hawaii (Wong, 1998). Region 9 sampled a well that was associated with an electric power plant. The findings revealed high metal levels due to the commingling of boiler blowdown wastes. (Therefore, the injectate has been chemically altered and would not qualify as noncontact cooling water defined for this study). There is also a report of a manufacturing factory in Hawaii that injected noncontact cooling water. The fluids released in this well contained acetone, so it is questionable if it would qualify as water that contains no additives or has not been chemically altered. A third noncontact cooling water well was located at a pineapple canning plant, but fluids released in this well were not sampled by USEPA Region 9.

Other than this anecdotal information, no data have been obtained on the quality of noncontact cooling water that is injected underground. Therefore, as a surrogate for such data, this summary relies on information on the quality of noncontact cooling water discharged to surface waters. It is important to keep in mind several distinctions between surface water intake/discharges and ground water intake/injections. Noncontact cooling water withdrawn from surface water has a greater variety of potential additives, especially biocides, such as those to control zebra mussel or lamprey infestation within the pipes (McRae, 1999). Water from ground water sources does not require such additives, except for algacides, bactericides, and/or fungicides.

There are a number of characteristics of concern to states regulating the discharge of noncontact cooling water to surface waters. National Pollutant Discharge Elimination System (NPDES) general permits for the states of Maine, Massachusetts, and New Hampshire, define noncontact cooling water as “water used to reduce temperature which does not come into direct contact with any raw material, intermediate product, waste product (other than heat), or finished product. Noncontact cooling water discharges are similar in composition even though they are not generated by a single industrial category or point source” (59 FR 22048, April 28, 1994)). For example, discharge permits for New Jersey, Maine, Massachusetts, and New Hampshire include limitations on the following effluent characteristics:

- C pH;
- C Changes in temperature due to discharge;
- C Total residual chlorine;
- C Volume of the discharge;
- C Total suspended solids;
- C Petroleum hydrocarbons;
- C Chemical oxygen demand;
- C Acute toxicity to aquatic organisms; and
- C Chronic toxicity to aquatic organisms.

The following sections summarize the results of two separate investigations of the quality of noncontact cooling water discharged to surface water in New Jersey and in Massachusetts and New Hampshire. Although the data are expected to be similar to NCWW injectate, these are not injectate data.

4.1.1 Discharge Monitoring Report from New Jersey

The New Jersey Department of Environmental Protection and Energy (NJDEPE) collected data for 36 industrial facilities that submitted discharge permit renewal applications and had active noncontact cooling water discharges from August 1991 to July 1992. The data compiled from this effort are documented in a *Discharge Monitoring Report* (DMR) and are summarized in Table 2. This table also compares the results to applicable standards, including primary drinking water maximum contaminant level (MCLs), secondary (non-health-based) MCLs, and health advisory levels (HALs).

Only two of the 36 facilities that were reviewed had detectable levels of copper and zinc. Measurable levels of chromium (i.e., equal to or greater than 0.1 mg/l) were not found at any facility. The minimum and maximum pH levels were reported to be slightly outside the secondary MCL range. All other parameters were reported to be less than applicable MCLs or HALs.

Table 2. DMR Data from 36 Facilities in New Jersey

Parameter	Minimum	Maximum	Average	Drinking Water Standards*		Health Advisory Levels**	
				mg/l	P/S	mg/l	N/C
Chemical Oxygen Demand (mg/l) ¹	0.5	3,777 ²	34.23 ³	-		-	
pH range (S.U.)	6.0	8.9	--	6.5-8.5	S	-	
Total Suspended Solids (mg/l)	ND	31	4.4	-		-	
Petroleum Hydrocarbons (mg/l)	--	88.5	1.9	-		-	
Chromium (mg/l)	--	< 0.1	--	0.1	P	-	
Copper (mg/l)	--	0.031	--	1.3/1	Action Level/S	-	
Zinc (mg/l)	--	0.209	--	5	S	2	N
Temperature (EC)	4.9	35.3	19.9	-		-	

¹Some of the data reported were indicated as a less than value. For these data points, one half of the less than value was used as the data point for purposes of estimating an average.

²This was the highest value reported in the DMR and is not expected to be representative of the true range of data points. A more representative maximum is expected to be 49 mg/l.

³This is the calculated average utilizing all data points. The average value excluding the two data points which are not expected to be representative of the true range of data points is 8.76.

Source: NJDEPE, 1994.

* Drinking Water Standards: P=Primary; S=Secondary.

** Health Advisory Levels: N=Noncancer Lifetime; C=Cancer Risk.

-- No data available.

- No standards of advisory levels available.

4.1.2 Toxicity Characterization Study from Massachusetts and New Hampshire

In November 1991, the Environmental Services Division from USEPA Region 1 conducted a study on the toxicity of noncontact cooling water discharges to surface water in Massachusetts and New Hampshire. USEPA collected grab samples from 16 outfalls and three individual plant water sources. Acute or chronic toxicity tests were conducted on the effluents from these sources using the fat head minnow (Pimephales promelas) and the water flea (Ceriodaphnia dubia).

This study showed that a majority of the noncontact cooling water discharges that were tested caused significant acute or chronic toxicity to these aquatic organisms. Test results reported acute toxicity (LC50) levels as low as 3.4 percent effluent, and chronic toxicity (no observed effect concentrations) as low as 2.5 percent effluent. USEPA stated that the possible causes for this toxicity included (NJDEPE, 1994):

- C Contaminated source water;
- C Presence of metals in the discharges; and
- C Use of biocides or cooling water additives (i.e., chlorine) in the discharges.

These biocides and corrosion inhibitors are “toxic to aquatic life and would need to be closely monitored and require periodic bioassay testing as well as toxicity limitations.” In New Jersey, those facilities that add copper, chromium, or zinc as corrosion inhibitors are required to have individual permits (NJDEPE, 1994).

New Jersey facilities that use chlorine as a biocide also do not qualify for a general permit because chlorine has been proven to be toxic to aquatic biota. Chlorine, however, is a parameter that is commonly found in public water supplies in low levels. The general permit discussion states that a database is necessary to further examine Chlorine Produced Oxidants (NJDEPE, 1994). The New Jersey general permit only allows biocides that are non-toxic.

Because the cooling waters tested in this study contained biocides, the resulting toxicity characterization is not representative of noncontact cooling water “that contains no additives,” which is of interest in this study. New Jersey now requires toxicity characterization studies in their permit for discharges of noncontact cooling water containing biocides to surface water.

4.2 Well Characteristics

Cooling water return flow wells are typically shallow and drain fluid by gravity. Design and construction varies greatly with the volume of injectate and local conditions. Cooling water return flow wells may be designed as open or closed systems. The most common design is the closed system, which withdraws ground water, uses it in closed pipes for cooling without ever exposing the water to air, and then injects the water back into the same underground formation from which it came (USEPA, 1987). In contrast, open systems expose ground water to the air at some point before re-injection.

In Snyder and Lee (1980), several types of applications for ground water cooling systems are described. The simplest systems are used for direct cooling, and employ either a shell and tube heat exchanger or the “fan and coil” system, which cools air exposed to a coil filled with cold ground water. Figure 1 shows schematics of these designs.

Cooling water return flows wells are sometimes used by power plants. For example, Hawaii Electric Company reports that their subsidiary utilities use noncontact cooling water return flow wells. The utilities have onsite source wells that supply cooling water for the power plant condensers, which is subsequently injected through a Class V well (Bonnet, 1995).

However, officials reported that due to differing hydrological conditions, ground water does not always provide enough cooling water for large industries in New Jersey such as power plants. As a result, large industries more commonly use surface water intakes for large-scale cooling, and most NCWWs are likely to be used by small businesses (Manhas, 1999).

The primary use of such wells is to dispose of used cooling water. However, they also may be used to inject water to prevent subsidence and to avoid depletion of ground water supplies. For example, Lichtler et al. (1980) documented two cooling water injection wells that also provided aquifer recharge in Aurora, Nebraska. According to the authors, in order to accomplish these other objectives besides disposal, wells injecting noncontact cooling water would have to be sited in locations where it is important to prevent subsidence or maintain ground water recharge.

4.3 Operational Practices

No information was obtained through the Class V survey on the operational practices of NCWWs.

5. POTENTIAL AND DOCUMENTED DAMAGE TO USDWs

There is no evidence that any constituents in NCWW injectate, as narrowly defined for this study, exceed any health-based standards. However, there is one case where documented contamination was caused by a cooling water well. Eckhardt and Pearsall (1989) documented a case of ground water contamination in which cooling water injection wells spread contamination from a deep aquifer, which served as the original water source, to a shallow aquifer, which received the water after it was used. Ground water contaminated with trichloroethylene (TCE), 1,2-dichloroethylene (DCE), and tetrachloroethylene (PCE) was withdrawn from the Magothy aquifer in Roosevelt Field on Long Island, New York, and injected into an overlying aquifer. The original source of the contamination, the well structure, and the type of cooling water return well (i.e., open, closed, or contact) are unknown. In any case, however, the injectate was not the relatively “clean” noncontact cooling water envisioned for the “other industrial” well category proposed in the July 29, 1998 notice of proposed rulemaking because the feedwater was originally contaminated.

Figure 1. Ground Water Cooling Systems for Direct Cooling

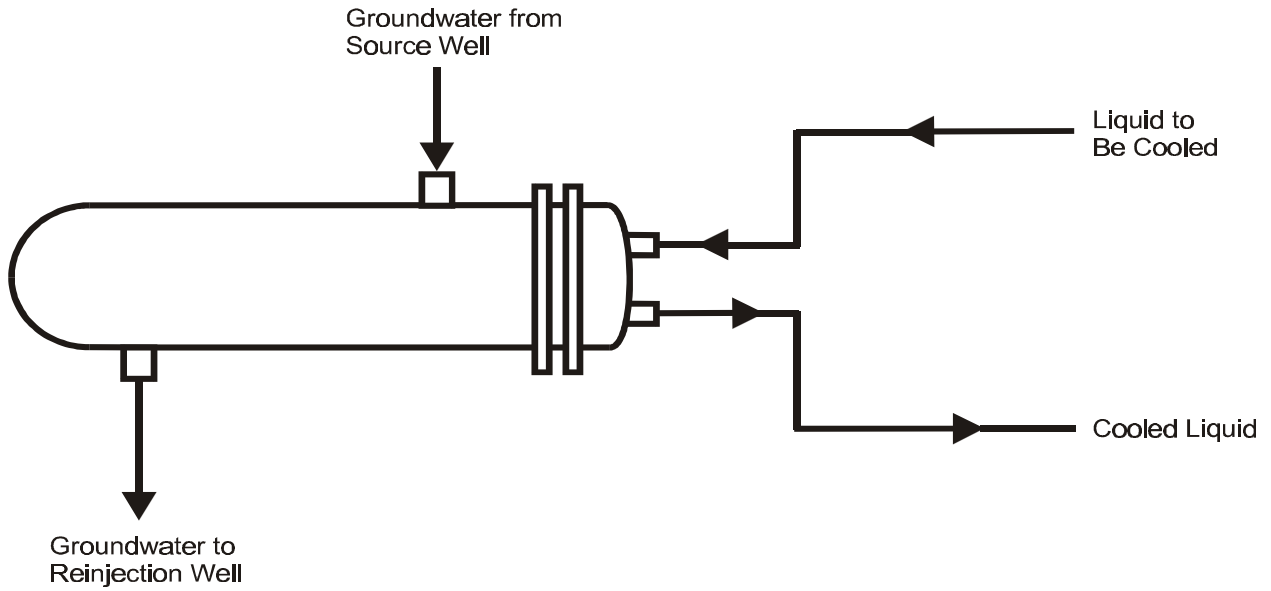

(A) Shell and Tube Heat Exchanger

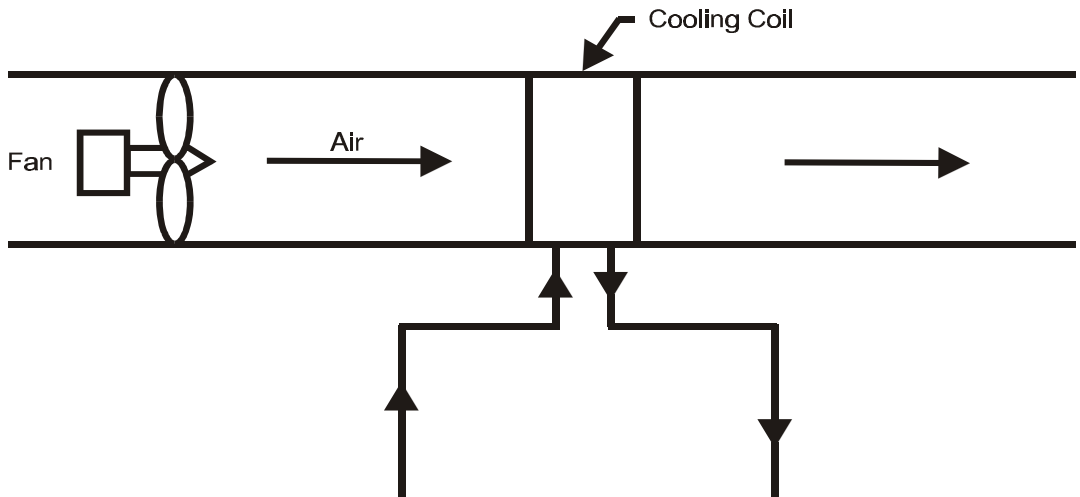

(B) Water to Air Heat Exchanger

Source: Snyder and Lee, 1980

6. BEST MANAGEMENT PRACTICES

Noncontact cooling water systems can be designed to shut down automatically in the event of a pressure loss due to a pipe leak below ground. In addition, noncontact cooling water systems can use a heat-conductive, but nearly impermeable, grout material to fill the casing surrounding circulation piping, helping reduce the possibility of a leak.

In general, the use of noncontact cooling water is thought to be a best management practice in itself because the water can be reused. The use of additives, as discussed in Section 4, is a major issue in determining if this practice is sound. From an environmental standpoint, the use of non-toxic additives are obviously preferable to toxic additives such as chlorine, copper, zinc, and chromium.

7. CURRENT REGULATORY REQUIREMENTS

Several federal, state, and local programs exist that either directly manage or regulate Class V NCWWs. On the federal level, management and regulation of these wells falls primarily under the UIC program authorized by the Safe Drinking Water Act (SDWA). Some states and localities have used these authorities, as well as their own authorities, to extend the controls in their areas to address concerns associated with NCWWs. Although not targeted to underground injection, general permits for discharges of noncontact cooling water have been issued under the Clean Water Act (CWA).

7.1 Federal Programs

7.1.1 SDWA

Class V wells are regulated under the authority of Part C of SDWA. Congress enacted the SDWA to ensure protection of the quality of drinking water in the United States, and Part C specifically mandates the regulation of underground injection of fluids through wells. USEPA has promulgated a series of UIC regulations under this authority. USEPA directly implements these regulations for Class V wells in 19 states or territories (Alaska, American Samoa, Arizona, California, Colorado, Hawaii, Indiana, Iowa, Kentucky, Michigan, Minnesota, Montana, New York, Pennsylvania, South Dakota, Tennessee, Virginia, Virgin Islands, and Washington, DC). USEPA also directly implements all Class V UIC programs on Tribal lands. In all other states, which are called Primacy States, state agencies implement the Class V UIC program, with primary enforcement responsibility.

Noncontact cooling water wells currently are not subject to any specific regulations tailored just for them, but rather are subject to the UIC regulations that exist for all Class V wells. Under 40 CFR 144.12(a), owners or operators of all injection wells, including noncontact cooling water wells are prohibited from engaging in any injection activity that allows the movement of fluids containing any contaminant into USDWs, “if the presence of that contaminant may cause a violation of any primary drinking water regulation . . . or may otherwise adversely affect the health of persons.”

Owners or operators of Class V wells are required to submit basic inventory information under 40 CFR 144.26. When the owner or operator submits inventory information and is operating the well such that a USDW is not endangered, the operation of the Class V well is authorized by rule. Moreover, under section 144.27, USEPA may require owners or operators of any Class V well, in USEPA-administered programs, to submit additional information deemed necessary to protect USDWs. Owners or operators who fail to submit the information required under sections 144.26 and 144.27 are prohibited from using their wells.

Sections 144.12(c) and (d) prescribe mandatory and discretionary actions to be taken by the UIC Program Director if a Class V well is not in compliance with section 144.12(a). Specifically, the Director must choose between requiring the injector to apply for an individual permit, ordering such action as closure of the well to prevent endangerment, or taking an enforcement action. Because noncontact cooling water wells (like other kinds of Class V wells) are authorized by rule, they do not have to obtain a permit unless required to do so by the UIC Program Director under 40 CFR 144.25. Authorization by rule terminates upon the effective date of a permit issued or upon proper closure of the well.

Separate from the UIC program, the SDWA Amendments of 1996 establish a requirement for source water assessments. USEPA published guidance describing how the states should carry out a source water assessment program within the state's boundaries. The final guidance, entitled *Source Water Assessment and Programs Guidance* (USEPA 816-R-97-009), was released in August 1997.

State staff must conduct source water assessments that are comprised of three steps. First, state staff must delineate the boundaries of the assessment areas in the state from which one or more public drinking water systems receive supplies of drinking water. In delineating these areas, state staff must use "all reasonably available hydrogeologic information on the sources of the supply of drinking water in the state and the water flow, recharge, and discharge and any other reliable information as the state deems necessary to adequately determine such areas." Second, the state staff must identify contaminants of concern, and for those contaminants, they must inventory significant potential sources of contamination in delineated source water protection areas. Class V wells, including noncontact cooling water wells, should be considered as part of this source inventory, if present in a given area. Third, the state staff must "determine the susceptibility of the public water systems in the delineated area to such contaminants." State staff should complete all of these steps by May 2003 according to the final guidance.²

7.1.2 CWA

There are no national effluent guidelines for noncontact cooling water discharges to surface water, which might have some partial applicability to ground water discharges. Instead, USEPA has issued general permits for surface water discharges. USEPA's regulations authorize the issuance of general permits to categories of discharges (40 CFR §122.28). General permits

² May 2003 is the deadline including an 18-month extension.

are warranted by similarities in environmental conditions, state regulatory requirements, and the type of technology employed.

7.2 State and Local Programs

As discussed in Section 3 above, 98% of the documented and 98% of the estimated NCWWs in the nation exist in ten states: Ohio, New York, West Virginia, Alabama, Tennessee, Ohio, Iowa, Montana, California, Alaska, and Washington. Attachment A of this volume describes how each of these states currently address NCWWS.

The statutory and regulatory frameworks for injection wells associated with NCWWs in the states that indicate the largest number of wells fall into two major groups.

- C USEPA directly implements the UIC Class V program in six of the states with relatively large numbers of NCWWs: Alaska, Iowa, Montana, California, New York, and Tennessee. In Alaska, Iowa, and Montana, the USEPA Region applies inventory and permit by rule requirements to ensure non-endangerment of USDWs. In California, New York, and Tennessee, the state also has water quality control requirements that it can use to prescribe requirements for discharges into the waters of the state. These water quality control programs can impose stringent permitting requirements, although in practice they apparently have not given priority to noncontact cooling water injection wells as subjects for regulation.

- C Ohio, West Virginia, Washington, and Alabama are UIC Primacy States for Class V wells. Although these states define cooling water wells as Class V wells in their state regulations, they frequently do not specify that the injected water targeted by the regulations is noncontact cooling water (i.e., the regulations apply to both contact and noncontact cooling water). In some cases, wells are described as air conditioning wells, without clarifying whether the rules apply to heat pump/air conditioning wells. In most cases, applicable statutes do not establish requirements specifically targeted to noncontact cooling water wells. In two of these states, Ohio and West Virginia, cooling water wells are permitted by rule, with mandatory inventory requirements and a requirement for non-endangerment of USDWs. Alabama allows Class V wells that do not cause a violation of primary drinking water regulations under 40 CFR Part 142, and requires submission of information in a permit application describing the use of the injection well. Washington permits existing wells and prohibits new wells that inject industrial, municipal, or commercial waste fluids into or above a USDW and requires only inventory information from other wells.

ATTACHMENT A STATE AND LOCAL PROGRAM DESCRIPTIONS

This section describes the regulatory requirements of the following ten states that report having 98% of documented and estimated NCWWs in the U.S.: Alabama, Alaska, California, Iowa, Montana, New York, Ohio, Tennessee, Washington, and West Virginia.

Alabama

Alabama is a UIC Primacy State for Class V wells. The Alabama Department of Environmental Management (ADEM) has promulgated requirements for Class V UIC wells under Chapter 335 of the Alabama Administrative Code (AAC). Injection wells used for the injection of water previously used for cooling (cooling water return flow wells) are specifically defined as Class V wells in the state (335-6-8-.02 AAC). The Code specifies that “Class V wells may be allowed insofar as they do not cause a violation of primary drinking water regulations under 40 CFR Part 142” (335-6-8-.07 AAC).

Permitting

The operator of an existing or proposed Class V well must submit a permit application to ADEM that includes the following information (335-6-8-.14(a) through (e) AAC):

- C Facility name and location;
- C Name of owner and operator;
- C Legal contact;
- C Depth, general description, and use of the injection well; and
- C Description of pollutant injected, including physical and chemical characteristics.

ADEM is required by the Code to assess the possibility of adverse impact on a USDW posed by the well and to determine any special construction and operation requirements which may be required to protect a USDW (335-6-8-.15(1) AAC). If the ADEM determines that the proposed action may have an adverse impact on a USDW, the applicant may be required to submit a permit application in the manner prescribed for Class I and Class III wells. When those permit application requirements are applied, the permit application processing and issuance procedures will follow the rules set forth for Class I and III wells (335-6-8-.15(2) AAC).

Siting and Construction Requirements

Class V wells are required to be constructed in such a manner that they may not cause a violation of primary drinking water regulations, defined as 40 CFR Part 142 in USDWs. When required by ADEM, the wells must be constructed by a well driller licensed by ADEM (335-6-8-.25 AAC).

Operating Requirements

Class V wells are required to be operated in a manner that may not cause a violation of primary drinking water regulations under 40 CFR 142. ADEM may order the operator to take necessary actions to prevent violation, including closure of the well (335-6-8-.16 AAC).

A method of obtaining grab and composite samples of pollutants after all pretreatment and prior to injection must be provided at all sites. Spill prevention and control measures sufficient to protect surface and ground water from pollution must be taken at all sites (335-6-8-.22 AAC).

Monitoring requirements may be specified in the permit, by administrative order, by directive, or by inclusion in the plugging and abandonment plan (335-6-8-.28 AAC).

Plugging and Abandonment

A plugging and abandonment plan may be required by permit or administrative order. If necessary, it may be required to include aquifer cleanup procedures. If pollution of a USDW is suspected, ground water monitoring may be required after well abandonment (335-6-8-.27 AAC).

Alaska

USEPA Region 10 directly implements the UIC program for Class V injection wells in Alaska. In addition, Chapter 72 of the Alaska Administrative Code addresses wastewater disposal to ground water. Disposal of nondomestic wastewater is subject to restrictions in 18 AAC 072.500, including review and approval of a nondomestic wastewater system plan by the Alaska Department of Environmental Conservation.

California

USEPA Region 9 directly implements the UIC program for Class V injection wells in California. The California Water Quality Control Act (WQCA), however, establishes broad requirements for the coordination and control of water quality in the state, sets up a State Water Quality Control Board, and divides the state into nine regions, with a Regional Water Quality Control Board that is delegated responsibilities and authorities to coordinate and advance water quality in each region (Chapter 4 Article 2 WQCA). A Regional Water Quality Control Board can prescribe waste discharge requirements (WDRs) into the waters of the state (13263 WQCA). These WDRs can apply to injection wells (13263.5 and 13264(b)(3) WQCA). In addition, the WQCA specifies that no provision of the Act or ruling of the State Board or a Regional Board is a limitation on the power of a city or county to adopt and enforce additional regulations imposing further conditions, restrictions, or limitations with respect to the disposal of waste or any other activity which might degrade the quality of the waters of the state (13002 WQCA).

Although the Regional Water Quality Control Boards do not issue permits for injection wells, the WQCA provides that any person operating, or proposing to operate, an injection well

(as defined in §13051 WQCA) must file a report of the discharge, containing the information required by the Regional Board, with the appropriate Regional Board (13260(a)(3) WQCA). Furthermore, the Regional Board, after a hearing, may prescribe requirements for any proposed discharge, existing discharge, or material change in an existing discharge in order to implement any relevant regional water quality control plans that the RWQCB has adopted. The requirements also must take into account the beneficial uses to be protected, the water quality objectives reasonably required for that purpose, other waste discharges, and the factors that the WQCA requires the Regional Boards to take into account in developing water quality objectives, which are specified in §13241 of the WQCA ((13263(a) WQCA). However, a Regional Board may waive the requirements in 13260(a) and 13263(a) for a specific discharge or a specific type of discharge where the waiver is not against the public interest (13269(a) WQCA).

California counties take a variety of approaches to regulation of noncontact cooling water injection wells, with some prohibiting them. For example, Merced County prohibits the construction of “air conditioner” wells, defined as wells constructed to “return air conditioning coolant water to the ground” (Merced County Code 9.28.060.B and 9.28.020 D). This prohibition may apply to HAC return flow wells as well as non-contact cooling water wells. Yolo County regulates only those activities that are not appropriately regulated by the State Regional Water Quality Control Board and are deemed to warrant more stringent regulations due to particular conditions within the county. Yolo County requires permits for wells that fall into this category (Yolo County Code, Chapter 8, Water Quality, §§6-8.302, 6-8.602, 6-8.604).

Iowa

USEPA Region 7 directly implements the UIC program for Class V injection wells in Iowa. No state regulations apply directly to non-contact cooling water return flow wells. However, Iowa has enacted an anti-degradation policy to protect ground water from point sources of contamination to the maximum extent possible (Chapter 567-61 Iowa Administrative Code (IAC)).

Montana

USEPA Region 8 directly implements the UIC program for Class V injection wells in Montana. The Region applies inventory requirements and permit by rule to ensure non-endangerment. No state regulations apply to noncontact cooling water return flow wells.

New York

USEPA Region 2 directly implements the UIC program for Class V injection wells in New York. In addition, under the state’s Environmental Conservation Law, the Department of Environmental Conservation, Division of Water Resources (DWR) has promulgated regulations in the State Code Rules and Regulations, Title 6, Chapter X, Parts 703, 750 -758. These regulations establish water quality standards and effluent limitations, create a state pollutant discharge elimination system requiring permits for discharges into the waters of the state (which include ground water), specify that such discharges must comply with the standards in Part 703, and provide for monitoring in Part 756.

Permitting

Applications for a State Pollution Discharge Elimination System (SPDES) permit must describe the proposed discharge, supply such other information as the DWR requests, and be subject to public notice. SPDES permits must ensure compliance with effluent limitations and standards and will include schedules of compliance, monitoring requirements, and records and reports of activities (Parts 751 - 756).

Operating Requirements

Wells must meet effluent limits (Part 703) as determined by the state in the SPDES permit. Monitoring and reporting requirements as prescribed by the state in the SPDES permit must be met.

Ohio

Ohio is a UIC Primacy State for Class V wells. Regulations establishing the underground injection control program are in Chapter 3745-34 of the Ohio Administrative Code (OAC). Class V injection well definitions include cooling water return flow wells used to inject water previously used for cooling (3745-34-04 OAC).

Permitting

Any underground injection, except as authorized by permit or rule, is prohibited. The construction of any well required to have a permit is prohibited until the permit is issued (3745-34-06 OAC).

Injection into Class V injection wells is authorized by rule (3745-34-13 OAC). The state applies inventory requirements and a non-endangerment requirement. However, a drilling permit and an operating permit are required for injection of sewage, industrial wastes, or other wastes, as defined in § 6111.01 of the Ohio Revised Code, into or above a USDW (3745-34-13 OAC and 3745-34-14 OAC). Therefore, if the injectate is anticipated to exceed primary drinking water standards, MCLs or HALs, permits to install and operate the well are required.

Wells required to obtain an individual permit must submit detailed information, including location, formation into which the well is drilled, depth of well, nature of the injectate, and a topographical map showing the facility, other wells in the area, and treatment areas (3745-34-16(E) OAC).

Siting and Construction

There are no specific regulatory requirements for the siting and construction of wells permitted by rule. Wells required to obtain an individual permit must submit siting information and construction records.

Operating Requirements

There are no specific operating or monitoring requirements for wells permitted by rule. Injectate must meet drinking water standards at the point of injection, unless a permit allows otherwise. Permitted wells will have monthly and quarterly monitoring and reporting requirements (3745-34-26 (J) OAC).

Tennessee

USEPA Region 4 directly implements the UIC program for Class V injection wells in Tennessee. The Region applies inventory requirements and permit by rule to ensure non-endangerment. However, the state also has enacted a regulation addressing underground injection in Section 1200-4-6-.01 of the Tennessee Administrative Code (TAC) pursuant to the state's Water Quality Control Act. The statute protects all waters of the state, including ground water. The state's rules define cooling water return flow wells used to inject water previously used for cooling as Class V (1200-4-6.06(5)(c) TAC).

Permitting

Under the Tennessee rules, construction and operation of an injection well is prohibited unless authorized by an injection well permit or by a rule of the Tennessee Department of Environment and Conservation (DE&C) (1200-4-6.03 TAC). No permit may be issued or authorization by rule allowed where an injection well causes or allows the movement of fluid containing any contaminant that would result in the pollution of ground water classified under the state's classification system. A permit or authorization by rule must include terms and conditions reasonably necessary to protect ground water classified pursuant to 1200-4-6.05(1) from pollution (1200-4-6.04(1) TAC). Injection into Class V wells generally is authorized by rule, subject to compliance and demonstration of mechanical integrity (1200-4-6.07 TAC).

Siting and Construction

The variety of wells and uses preclude specific construction standards. A well must be designed and constructed for its intended use, in accordance with good engineering practices, and the design and construction must be approved by the DE&C. Wells must be constructed so that their intended use does not violate the water quality standards (1200-4-6-.14(7) TAC).

Operating Requirements

Wells are required to be operated in such a manner that they do not present a hazard to ground water (1200-4-6-.14(8) TAC). The well operator is required to monitor injection fluids, injection operations, and local ground water supplies in accordance with monitoring requirements determined by the type of well, nature of the injected fluid, and water quality of the receiving aquifer (91200-4-6-.14(9) TAC).

Plugging and Abandonment

The DE&C must approve a proposed plugging method and type of cement. Plugging may be carried out by any recognized method that is acceptable to DE&C (1200-4-6-.14(11) TAC).

Washington

Washington is a UIC Primacy State for Class V wells. Chapter 173-218 of the Washington Administrative Code (WAC) establishes the UIC program. Under the program, the policy of the Department of Ecology is to maintain the highest possible standards to prevent the injection of fluids that may endanger ground waters which are available for beneficial uses or which may contain fewer than 10,000 mg/l TDS. Consistent with that policy, all new Class V injection wells that inject industrial, municipal, or commercial waste fluids into or above a USDW are prohibited (172-218-090(1) WAC). Existing wells that inject industrial, municipal, or commercial waste fluids into or above a USDW must obtain a permit to operate. All other Class V injection well owners and operators must notify the WDOE and supply required inventory information (172-218-090 (2) and (3) WAC).

Permitting

A permit must specify conditions necessary to prevent and control injection of fluids into the waters of the state, including all known, available, and reasonable methods of prevention, control, and treatment; applicable requirements in 40 CFR Parts 124, 144, 146; and any conditions necessary to preserve and protect USDWs. Any injection well that causes or allows the movement of fluid into a USDW that may result in a violation of any primary drinking water standard under 40 CFR Part 141 or that may otherwise adversely affect the beneficial use of a USDW is prohibited (173-218-100 WAC). The state's Waste Discharge Permit Program, which prohibits the discharge of pollutants into waters of the state (which include ground water) without a permit (Chapter 173-216 WAC) does not apply to the injection of fluids through wells which are regulated by the UIC control program (173-216-010 WAC).

Siting and Construction

The state has promulgated minimum standards for construction and maintenance of wells (173-160-010 through -560 WAC). However, injection wells regulated under Chapter 173-218 are specifically exempted from these constructions standards (173-160-010(3)(e) WAC).

Operating Requirements

The water quality standards for ground waters establish an anti-degradation policy. The injectate must meet the state ground water standards at the point of compliance (173-200-030 WAC).

Plugging and Abandonment

All wells not in use must be securely capped so that no contamination can enter the well (173-160-085 WAC).

West Virginia

West Virginia is a UIC Primacy State for Class V wells. Regulations establishing the UIC program are found in Title 47-13 West Virginia Code of State Regulations. The state defines Class V cooling water return flow wells as wells used to inject water previously used for cooling (47-13-3.4.5.m WVAC).

Permitting

Class V injection wells are authorized by rule unless the Office of Water Resources of the Division of Environmental Protection requires an individual permit (47-13-12.4.a. and 47-13-13.2 WVAC). Injection is authorized initially for five years under the permit by rule provisions.

Operating Requirements

Owners or operators of Class V wells are required to submit inventory information describing the well, including its construction features, the nature and volume of injected fluids, alternative means of disposal, the environmental and economic consequences of well disposal and its alternatives, operation status, and location and ownership information (47-13-12.2 WVAC).

Rule authorized wells must meet the requirements for monitoring and records (requiring retention of records pursuant to 47-13-13.6.b. WVAC concerning the nature and composition of injected fluids until 3 years after completion of plugging and abandonment); immediate reporting of information indicating that any contaminant may cause an endangerment to USDWs or any malfunction of the injection system that might cause fluid migration into or between USDWs; and prior notice of abandonment.

The rules enact a general prohibition against any underground injection activity that causes or allows the movement of fluid containing any contaminant into a USDW, if the presence of that contaminant may cause a violation of any primary drinking water regulations under 40 CFR Part 142 or promulgated under the West Virginia Code or may adversely affect the health of persons. If at any time a Class V well may cause a violation of the primary drinking water rules the well may be required to obtain a permit or take other action, including closure, that will prevent the violation (47-13-13.1 WVAC). Inventory requirements for Class V wells include information regarding pollutant loads and schedules for attaining compliance with water quality standards (47-13-13.2.d.1 WVAC).

The injection operation may be required to satisfy requirements, such as for corrective action, monitoring, and reporting, or operation, that are not contained in the UIC rules (47-13-13.2.c.1.C. WVAC) if they are needed to protect the USDW.

REFERENCES

- Bonnet, W. A. 1995. Hawaiian Electric Company. Comments on the Class V Wells -- Regulatory Determination and Minor Revisions to the Underground Injection Control Regulations; Technical Correction to the Regulations for Class I Wells; Proposed Rule. October 27, 1995.
- Bose, L.T. 1997. USEPA Region 9 Ground Water Office. Memorandum to Clive Davies, USEPA Office of Water. November 21, 1997.
- The Cadmus Group. 1999. State-by-State Notebooks Compiling Results from the Class V Underground Injection Control Study. February 1, 1999.
- Eckhardt, D. A. V. and K. A. Pearsall. 1989. Chlorinated Organic Compounds in Ground water at Roosevelt Field, Nassau County, Long Island, New York. U.S. Geological Survey. USGS Water Resources Investigations Report 86-4333.
- Frayne, S. P. 1992. Minimize Plant Wastewater. Hydrocarbon Processing, v71, n8, p 79(4). August 1992.
- Lichtler, W. F., D. Stannard, and E. Kouma. 1980. Investigation of Artificial Recharge of Aquifers in Nebraska. U.S. Geological Survey. Reston, Virginia. Water-Resources Investigations Report 80-93.
- Manhas, B. 1999. New Jersey Department of Environmental Protection, Division of Water Quality, Bureau of Point Source Permitting. Telephone conversation with Vaishali Deshpande, ICF Consulting. April 1999.
- McRae, A. 1999. Michigan Department of Environmental Quality, Surface Water Quality Division. Telephone conversation with Vaishali Deshpande, ICF Consulting. April 1999.
- New Jersey Department of Environmental Protection and Energy (NJDEPE). 1994. Statement of Basis Draft NJPDES General Permit to Discharge Noncontact Cooling Water into the Waters of the State of New Jersey. NJPDES Permit No. NJ0070203.
- Snyder, M. and C.H. Lee. 1980. Survey of Reinjection Experience from Ground water Cooling Applications. PNL-3740. Kansas City, MO: Midwest Research Institute, Prepared for Pacific Northwest Laboratory, under Department of Energy Contract.
- Sorrells, S. Tennessee Department of Environment and Conservation. Telephone conversation with Vaishali Deshpande, ICF Consulting. April 1999.
- USEPA. 1987. Report to Congress: Class V Injection Wells. Office of Water. Washington, D.C. EPA570/9-87-006. September 1987.

Wilson, J., and Noonan, J.J. 1984. Microbial activity in model I aquifer systems. Ground water Pollution Microbiology. New York, NY. John Wiley and Sons, Inc.

Wong, A. 1998. U.S. USEPA Region 9. Email correspondence to Bindiya Patel, ICF Consulting. September 4, 1998.