

---

**Method 1637**

**Determination of Trace Elements in Ambient Waters by Off-Line Chelation  
Preconcentration and Stabilized Temperature Graphite Furnace Atomic Absorption**

---

**January 1996**

**U.S. Environmental Protection Agency  
Office of Water  
Engineering and Analysis Division (4303)  
401 M Street S.W.  
Washington, D.C. 20460**

## Acknowledgments

Method 1637 was prepared under the direction of William A. Telliard of the U.S. Environmental Protection Agency's (EPA's) Office of Water (OW), Engineering and Analysis Division (EAD). The method was prepared under EPA Contract 68-C3-0337 by the DynCorp Environmental Programs Division with assistance from Interface, Inc.

The following researchers in marine chemistry contributed to the philosophy behind this method. Their contribution is gratefully acknowledged:

Shier Berman, National Research Council, Ottawa, Ontario, Canada  
Nicholas Bloom, Frontier Geosciences Inc., Seattle, Washington  
Paul Boothe and Gary Steinmetz, Texas A&M University, College Station, Texas  
Eric Crecelius, Battelle Marine Sciences Laboratory, Sequim, Washington  
Russell Flegal, University of California/Santa Cruz, California  
Gary Gill, Texas A&M University at Galveston, Texas  
Carlton Hunt and Dion Lewis, Battelle Ocean Sciences, Duxbury, Massachusetts  
Carl Watras, Wisconsin Department of Natural Resources, Boulder Junction, Wisconsin  
Herb Windom and Ralph Smith, Skidaway Institute of Oceanography, Savannah, Georgia

In addition, J.T. Creed and T.D. Martin of the EPA Office of Research and Development's Environmental Monitoring Systems Laboratory in Cincinnati, Ohio, are gratefully acknowledged for the development of the analytical procedures described in this method.

## Disclaimer

This method has been reviewed and approved for publication by the Engineering and Analysis Division of the U.S. Environmental Protection Agency. Mention of trade names or commercial products does not constitute endorsement or recommendation for use.

Questions concerning this method or its application should be addressed to:

W.A. Telliard  
U.S. Environmental Protection Agency  
Office of Water  
Analytical Methods Staff  
Mail Code 4303  
401 M Street SW  
Washington, DC 20460  
202/260-7120

---

## Introduction

This analytical method was designed to support water quality monitoring programs authorized under the Clean Water Act. Section 304(a) of the Clean Water Act requires EPA to publish water quality criteria that reflect the latest scientific knowledge concerning the physical fate (e.g., concentration and dispersal) of pollutants, the effects of pollutants on ecological and human health, and the effect of pollutants on biological community diversity, productivity, and stability.

Section 303 of the Clean Water Act requires states to set a water quality standard for each body of water within its boundaries. A state water quality standard consists of a designated use or uses of a waterbody or a segment of a waterbody, the water quality criteria that are necessary to protect the designated use or uses, and an antidegradation policy. These water quality standards serve two purposes: (1) they establish the water quality goals for a specific waterbody, and (2) they are the basis for establishing water quality-based treatment controls and strategies beyond the technology-based controls required by Sections 301(b) and 306 of the Clean Water Act.

In defining water quality standards, the state may use narrative criteria, numeric criteria, or both. However, the 1987 amendments to the Clean Water Act required states to adopt numeric criteria for toxic pollutants (designated in Section 307(a) of the Act) based on EPA Section 304(a) criteria or other scientific data, when the discharge or presence of those toxic pollutants could reasonably be expected to interfere with designated uses.

In some cases, these water quality criteria are as much as 280 times lower than those achievable using existing EPA methods and required to support technology-based permits. Therefore, EPA developed new sampling and analysis methods to specifically address state needs for measuring toxic metals at water quality criteria levels, when such measurements are necessary to protect designated uses in state water quality standards. The latest criteria published by EPA are those listed in the National Toxics Rule (57 *FR* 60848) and the Stay of Federal Water Quality Criteria for Metals (60 *FR* 22228). These rules include water quality criteria for 13 metals, and it is these criteria on which the new sampling and analysis methods are based. Method 1637 was specifically developed to provide reliable measurements of two of these metals at EPA WQC levels using off-line chelation preconcentration and stabilized temperature graphite furnace atomic absorption techniques.

In developing these methods, EPA found that one of the greatest difficulties in measuring pollutants at these levels was precluding sample contamination during collection, transport, and analysis. The degree of difficulty, however, is highly dependent on the metal and site-specific conditions. This analytical method, therefore, is designed to provide the level of protection necessary to preclude contamination in nearly all situations. It is also designed to provide the procedures necessary to produce reliable results at the lowest possible water quality criteria published by EPA. In recognition of the variety of situations to which this method may be applied, and in recognition of continuing technological advances, the method is performance based. Alternative procedures may be used, so long as those procedures are demonstrated to yield reliable results.

Requests for additional copies should be directed to:

U.S. EPA NCEPI  
11029 Kenwood Road  
Cincinnati, OH 45242  
513/489-8190

Note: This method is intended to be performance based, and the laboratory is permitted to omit any step or modify any procedure provided that *all* performance requirements set forth in this method are met. The laboratory is *not* allowed to omit any quality control analyses. The terms "must," "may," and "should" are included throughout this method and are intended to illustrate the importance of the procedures in producing verifiable data at water quality criteria levels. The term "must" is used to indicate that researchers in trace metals analysis have found certain procedures essential in successfully analyzing samples and avoiding contamination; however, these procedure can be modified or omitted if the laboratory can demonstrate that data quality is not affected.

**Method 1637**  
**Determination of Trace Elements in Ambient Waters by Off-Line Chelation**  
**Preconcentration and Stabilized Temperature Graphite**  
**Furnace Atomic Absorption**

**1.0 Scope and Application**

1.1 This method provides procedures for the determination of dissolved elements in ambient waters at EPA water quality criteria (WQC) levels using off-line chelation preconcentration and stabilized temperature graphite furnace atomic absorption (GFAA). It may also be used for determination of total recoverable element concentrations in these waters. This method was developed by integrating the analytical procedures in EPA Method 200.13 with the stringent quality control (QC) and sample handling procedures necessary to avoid contamination and ensure the validity of analytical results during sampling and analysis for metals at EPA WQC levels. This method contains QC procedures that will ensure that contamination will be detected when blanks accompanying samples are analyzed. This method is accompanied by Method 1669: *Sampling Ambient Water for Determination of Trace Metals at EPA Water Quality Criteria Levels* (the "Sampling Method"). The Sampling Method is necessary to ensure that contamination will not compromise trace metals determinations during the sampling process.

1.2 This method is applicable to the following analytes:

Analyte	Symbol	Chemical Abstract Services Registry Number (CASRN)
Cadmium	(Cd)	7440-43-9
Lead	(Pb)	7439-92-1

Table 1 lists the EPA WQC levels, the method detection limit (MDL) for each metal, and the minimum level (ML) set for each metal in this method. Instrument operating conditions for the applicable elements are listed in Table 3. These are intended as a guide and are typical of a system optimized for the element employing commercial instrumentation. However, actual linear working ranges will be dependent on the sample matrix, instrumentation, and selected operating conditions.

1.3 This method is not intended for determination of metals at concentrations normally found in treated and untreated discharges from industrial facilities. Existing regulations (40 CFR Parts 400-500) typically limit concentrations in industrial discharges to the mid to high part-per-billion (ppb) range, whereas ambient metals concentrations are normally in the low part-per-trillion (ppt) to low ppb range.

1.4 The ease of contaminating ambient water samples with the metal(s) of interest and interfering substances cannot be overemphasized. This method includes suggestions for improvements in facilities and analytical techniques that should maximize the ability of the laboratory to make reliable trace metals determinations and minimize contamination. These suggestions are given in Section 4.0 and are based on findings of researchers performing trace metals analyses (References 1-8). Additional suggestions for improvement of existing facilities may be found in EPA's *Guidance for Establishing Trace*

*Metals Clean Rooms in Existing Facilities*, which is available from the EPA National Center for Environmental Publications and Information (NCEPI) at the address listed in the introduction to this document.

- 1.5 Clean and Ultraclean—The terms "clean" and "ultraclean" have been applied to the techniques needed to reduce or eliminate contamination in trace metals determinations. These terms are not used in this method because they lack an exact definition. However, the information provided in this method is consistent with and copied from summary guidance on clean and ultraclean techniques (Reference 9).
- 1.6 This method follows the EPA Environmental Methods Management Council's "Format for Method Documentation" (Reference 10).
- 1.7 This method is "performance based"; i.e., an alternate procedure or technique may be used as long as the performance requirements in the method are met. Section 9.1.2 gives details of the tests and documentation required to support equivalent performance.
- 1.8 For dissolved metal determinations, samples must be filtered through a 0.45 µm capsule filter at the field site. The Sampling Method describes the filtering procedures. The filtered samples may be preserved in the field or transported to the laboratory for preservation. Procedures for field preservation are detailed in the Sampling Method; procedures for laboratory preservation are provided in this method.
- 1.9 For the determination of total recoverable analytes in ambient water samples, a digestion/extraction is required before analysis when the elements are not in solution (e.g., aqueous samples that may contain particulate and suspended solids).
- 1.10 The sensitivity and limited linear dynamic range (LDR) of GFAA often implies the need to dilute a sample before analysis. The actual magnitude of the dilution as well as the cleanliness of the labware used to perform the dilution can dramatically influence the quality of the analytical results. Therefore, sample types requiring large dilutions (>50:1) should be analyzed by an another approved test procedure that has a larger LDR or is inherently less sensitive than GFAA.
- 1.11 This method should be used by analysts experienced in the use of graphite furnace atomic absorption spectroscopy, the interpretation of spectral and matrix interferences, and procedures for their correction, and only by personnel thoroughly trained in the handling and analysis of samples for determination of metals at EPA WQC levels. A minimum of six months experience with commercial instrumentation is recommended.
- 1.12 This method is accompanied by a data verification and validation guidance document, *Guidance on the Documentation and Evaluation of Trace Metals Data Collected for CWA Compliance Monitoring*. Before using this method, data users should state the data quality objectives (DQOs) required for a project.

## 2.0 Summary of Method

- 2.1 An aliquot of a well-mixed, homogeneous aqueous sample is accurately measured for sample processing. For total recoverable analysis of an aqueous sample containing undissolved material, analytes are first solubilized by gentle refluxing with nitric acid. After cooling, the sample is made up to volume, mixed, and centrifuged or allowed to settle overnight before analysis. For the determination of dissolved analytes in a filtered aqueous sample aliquot, the sample is made ready for analysis by the appropriate addition of nitric acid, and then diluted to a predetermined volume and mixed before analysis.
- 2.2 This method is used to preconcentrate trace elements using an iminodiacetate functionalized chelating resin (References 11 and 12). After a sample is prepared, it is buffered using an on-line system before it enters the chelating column. Group I and II metals, as well as most anions, are selectively separated from the analytes by elution with ammonium acetate at pH 5.5. The analytes are subsequently eluted into a simplified matrix consisting of 0.75 M nitric acid and are determined by stabilized temperature platform graphite furnace atomic absorption (STPGFAA).
- 2.3 In STPGFAA, the sample and the matrix modifier are first pipetted onto the platform or a device that provides delayed atomization. The furnace chamber is then purged with a continuous flow of a premixed gas (95% argon-5% hydrogen) and the sample is dried at a relatively low temperature (about 120°C) to avoid spattering. Once dried, the sample is pretreated in a char or ashing step that is designed to minimize the interference effects caused by the concomitant sample matrix. After the char step, the furnace is allowed to cool before atomization. The atomization cycle is characterized by rapid heating of the furnace to a temperature at which the metal (analyte) is atomized from the pyrolytic graphite surface into a stopped gas flow atmosphere of argon containing 5% hydrogen. The resulting atomic cloud absorbs the element specific atomic emission produced by a hollow cathode lamp (HCL) or an electrodeless discharge lamp (EDL). After analysis, the furnace is subjected to a cleanout period of high temperature and continuous argon flow. Because the resulting absorbance usually has a nonspecific component associated with the actual analyte absorbance, an instrumental background correction device is required to subtract from the total signal the component that is nonspecific to the analyte. In the absence of interferences, the background corrected absorbance is directly related to the concentration of the analyte. Interferences relating to STPGFAA (Section 4.0) must be recognized and corrected.Suppressions or enhancements of instrument response caused by the sample matrix must be corrected by the method of standard addition (Section 12.6).

## 3.0 Definitions

- 3.1 Apparatus—Throughout this method, the sample containers, sampling devices, instrumentation, and all other materials and devices used in sample collection, sample processing, and sample analysis activities will be referred to collectively as the Apparatus.
- 3.2 Other definitions of terms are given in the glossary (Section 18) at the end of this method.

## 4.0 Contamination and Interferences

- 4.1 Preventing ambient water samples from becoming contaminated during the sampling and analytical process constitutes one of the greatest difficulties encountered with trace metals determinations. Over the last two decades, marine chemists have come to recognize that much of the historical data on the concentrations of dissolved trace metals in seawater are erroneously high because the concentrations reflect contamination from sampling and analysis rather than ambient levels. More recently, historical trace metals data collected from freshwater rivers and streams have been shown to be similarly biased because of contamination during sampling and analysis (Reference 13). Therefore, it is imperative that extreme care be taken to avoid contamination when collecting and analyzing ambient water samples for trace metals.
- 4.2 Samples may become contaminated by numerous routes. Potential sources of trace metals contamination during sampling include metallic or metal-containing labware (e.g., talc gloves which contain high levels of zinc), containers, sampling equipment, reagents, and reagent water; improperly cleaned and stored equipment, labware, and reagents; and atmospheric inputs such as dirt and dust. Even human contact can be a source of trace metals contamination. For example, it has been demonstrated that dental work (e.g., mercury amalgam fillings) in the mouths of laboratory personnel can contaminate samples that are directly exposed to exhalation (Reference 3).
- 4.3 Contamination Control
- 4.3.1 Philosophy—The philosophy behind contamination control is to ensure that any object or substance that contacts the sample is metal free and free from any material that may contain metals.
- 4.3.1.1 The integrity of the results produced cannot be compromised by contamination of samples. This method and the Sampling Method give requirements and suggestions for controlling sample contamination.
- 4.3.1.2 Substances in a sample cannot be allowed to contaminate the laboratory work area or instrumentation used for trace metals measurements. This method gives requirements and suggestions for protecting the laboratory.
- 4.3.1.3 Although contamination control is essential, personnel health and safety remain the highest priority. The Sampling Method and Section 5 of this method give requirements and suggestions for personnel safety.
- 4.3.2 Avoid contamination—The best way to control contamination is to completely avoid exposure of the sample to contamination in the first place. Avoiding exposure means performing operations in an area known or thought to be free from contamination. Two of the most important factors in avoiding/reducing sample contamination are (1) an awareness of potential sources of contamination and (2) strict attention to work being done. Therefore, it is imperative that the procedures described in this method be carried out by well-trained, experienced personnel.
- 4.3.3 Use a clean environment—The ideal environment for processing samples is a class 100 clean room (Section 6.1.1). If a clean room is not available, all sample preparation must be performed in a class 100 clean bench or a nonmetal glove



box fed by particle-free air or nitrogen. Digestions must be performed in a nonmetal fume hood, ideally situated in the clean room.

- 4.3.4 Minimize exposure—The Apparatus that will contact samples, blanks, or standard solutions must only be opened or exposed in a clean room, clean bench, or glove box so that exposure to an uncontrolled atmosphere is minimized. When not being used, the Apparatus should be covered with clean plastic wrap, stored in the clean bench or in a plastic box or glove box, or bagged in clean zip-type bags. Minimizing the time between cleaning and use will also minimize contamination.
- 4.3.5 Clean work surfaces—Before processing a given batch of samples, all work surfaces in the hood, clean bench, or glove box in which the samples will be processed should be cleaned by wiping with a lint-free cloth or wipe soaked with reagent water.
- 4.3.6 Wear gloves—Sampling personnel must wear clean, nontalc gloves (Section 6.10.7) during all operations involving handling of the Apparatus, samples, and blanks. Only clean gloves may touch the Apparatus. If another object or substance is touched, the glove(s) must be changed before again handling the Apparatus. If it is even suspected that gloves have become contaminated, work must be halted, the contaminated gloves removed, and a new pair of clean gloves put on. Wearing multiple layers of clean gloves will allow the old pair to be quickly stripped with minimal disruption to the work activity.
- 4.3.7 Use metal-free Apparatus—All Apparatus used for metals determinations at ambient water quality criteria levels must be nonmetallic, free of material that may contain metals, or both.
- 4.3.7.1 Construction materials—Only the following materials should come in contact with samples: fluoropolymer (FEP, PTFE), conventional or linear polyethylene, polycarbonate, polypropylene, polysulfone, or ultrapure quartz. PTFE is less desirable than FEP because the sintered material in PTFE may contain contaminants and is susceptible to serious mercury contamination (Reference 6). Fluoropolymer or glass containers should be used for samples that will be analyzed for mercury because mercury vapors can diffuse in or out of the other materials resulting either in contamination or low-biased results (Reference 3). All materials, regardless of construction, that will directly or indirectly contact the sample must be cleaned using the procedures described in Section 11.0 and must be known to be clean and metal free before proceeding.
- 4.3.7.2 The following materials have been found to contain trace metals and must not be used to hold liquids that come in contact with the sample or must not contact the sample itself, *unless* these materials have been shown to be free of the metals of interest at the desired level: Pyrex, Kimax, methacrylate, polyvinylchloride, nylon, and Vycor (Reference 6). In addition, highly colored plastics, paper cap liners, pigments used to mark increments on plastics, and rubber all contain trace levels of metals and must be avoided (Reference 14).

- 4.3.7.3 **Serialization**—It is recommended that serial numbers be indelibly marked or etched on each piece of Apparatus so that contamination can be traced, and logbooks should be maintained to track the sample from the container through the labware to injection into the instrument. It may be useful to dedicate separate sets of labware to different sample types; e.g., receiving waters vs. effluents. However, the Apparatus used for processing blanks and standards must be mixed with the Apparatus used to process samples so that contamination of all labware can be detected.
- 4.3.7.4 The laboratory or cleaning facility is responsible for cleaning the Apparatus used by the sampling team. If there are any indications that the Apparatus is not clean when received by the sampling team (e.g., ripped storage bags), an assessment of the likelihood of contamination must be made. Sampling must not proceed if it is possible that the Apparatus is contaminated. If the Apparatus is contaminated, it must be returned to the laboratory or cleaning facility for proper cleaning before any sampling activity resumes.
- 4.3.8 **Avoid sources of contamination**—Avoid contamination by being aware of potential sources and routes of contamination.
- 4.3.8.1 **Contamination by carryover**—Contamination may occur when a sample containing low concentrations of metals is processed immediately after a sample containing relatively high concentrations of these metals. To reduce carryover, the sample introduction system may be rinsed between samples with dilute acid and reagent water. When an unusually concentrated sample is encountered, it is followed by analysis of a laboratory blank to check for carryover. For samples containing high levels of metals, it may be necessary to acid-clean or replace the connecting tubing or inlet system to ensure that contamination will not affect subsequent measurements. Samples known or suspected to contain the lowest concentration of metals should be analyzed first followed by samples containing higher levels. For instruments containing autosamplers, the laboratory should keep track of which station is used for a given sample. When an unusually high concentration of a metal is detected in a sample, the station used for that sample should be cleaned more thoroughly to prevent contamination of subsequent samples, and the results for subsequent samples should be checked for evidence of the metal(s) that occurred in high concentration.
- 4.3.8.2 **Contamination by samples**—Significant laboratory or instrument contamination may result when untreated effluents, in-process waters, landfill leachates, and other samples containing high concentrations of inorganic substances are processed and analyzed. As stated in Section 1.0, this method is not intended for application to these samples, and samples containing high concentrations should not be permitted into the clean room and laboratory dedicated for processing trace metals samples.
- 4.3.8.3 **Contamination by indirect contact**—Apparatus that may not directly come in contact with the samples may still be a source of contamination. For example, clean tubing placed in a dirty plastic bag may pick up

contamination from the bag and then subsequently transfer the contamination to the sample. Therefore, it is imperative that every piece of the Apparatus that is directly or indirectly used in the collection, processing, and analysis of ambient water samples be cleaned as specified in Section 11.0.

4.3.8.4 Contamination by airborne particulate matter—Less obvious substances capable of contaminating samples include airborne particles. Samples may be contaminated by airborne dust, dirt, particles, or vapors from unfiltered air supplies; nearby corroded or rusted pipes, wires, or other fixtures; or metal-containing paint. Whenever possible, sample processing and analysis should occur as far as possible from sources of airborne contamination.

4.4 Interferences—Several interference sources may cause inaccuracies in the determination of trace elements by GFAA. These interferences can be classified into three major subdivisions: spectral, matrix, and memory. Some of these interferences can be minimized through the preconcentration step, which reduces the Ca, Mg, Na, and chloride concentrations in the sample before GFAA analysis.

4.4.1 Spectral interferences are caused by the absorbance of light by a molecule or atom that is not the analyte of interest or emission from black body radiation.

4.4.1.1 Spectral interferences caused by an element only occur if there is a spectral overlap between the wavelength of the interfering element and the analyte of interest. Fortunately, this type of interference is relatively uncommon in STPGFAA because of the narrow atomic line widths associated with STPGFAA. In addition, the use of appropriate furnace temperature programs and high spectral purity lamps as light sources can minimize the possibility of this type of interference. However, molecular absorbances can span several hundred nanometers, producing broadband spectral interferences. This type of interference is far more common in STPGFAA. The use of matrix modifiers, selective volatilization, and background correctors are all attempts to eliminate unwanted nonspecific absorbance. Since the nonspecific component of the total absorbance can vary considerably from sample type to sample type, to provide effective background correction and eliminate elemental spectral interferences, the exclusive use of Zeeman background correction is specified in this method.

4.4.1.2 Spectral interferences are also caused by black body radiation produced during the atomization furnace cycle. This black body emission reaches the photomultiplier tube, producing erroneous results. The magnitude of this interference can be minimized by proper furnace tube alignment and monochromator design. In addition, atomization temperatures that adequately volatilize the analyte of interest without producing unnecessary black body radiation can help reduce unwanted background emission produced during atomization.

4.4.2 Matrix interferences are caused by sample components that inhibit the formation of free atomic analyte atoms during the atomization cycle. In this method, the

use of a delayed atomization device that provides warmer gas phase temperatures is required. These devices provide an environment that is more conducive to the formation of free analyte atoms and thereby minimize this type of interference. This type of interference can be detected by analyzing the sample plus a sample aliquot fortified with a known concentration of the analyte. If the determined concentration of the analyte addition is outside a designated range, a possible matrix effect should be suspected (Section 9.3)

- 4.4.3 Memory interferences result from analyzing a sample containing a high concentration of an element (typically a high atomization temperature element) that cannot be removed quantitatively in one complete set of furnace steps. The analyte that remains in the furnace can produce false positive signals on subsequent sample(s). Therefore, the analyst should establish the analyte concentration that can be injected into the furnace and adequately removed in one complete set of furnace cycles. If this concentration is exceeded, the sample should be diluted and a blank analyzed to ensure the memory effect has been eliminated before reanalyzing the diluted sample.
- 4.4.4 Low recoveries may be encountered in the preconcentration cycle if the trace elements are complexed by competing chelators (humic/fulvic) in the sample or are present as colloidal material. Acid solubilization pretreatment is used to improve analyte recovery and to minimize adsorption, hydrolysis, and precipitation effects.
- 4.4.5 Memory interferences from the chelating system may be encountered, especially after analyzing a sample containing high analyte concentrations. A thorough column rinsing sequence following elution of the analytes is necessary to minimize such interferences.

## 5.0 Safety

- 5.1 The toxicity or carcinogenicity of reagents used in this method have not been fully established. Each chemical should be regarded as a potential health hazard and exposure to these compounds should be as low as reasonably achievable.
  - 5.1.1 Each laboratory is responsible for maintaining a current awareness file of OSHA regulations for the safe handling of the chemicals specified in this method (References 15-18). A reference file of material safety data sheets (MSDSs) should also be available to all personnel involved in the chemical analysis. It is also suggested that the laboratory perform personal hygiene monitoring of each analyst who uses this method and that the results of this monitoring be made available to the analyst. The references and bibliography at the end of Reference 18 are particularly comprehensive in dealing with the general subject of laboratory safety.
  - 5.1.2 Concentrated nitric and hydrochloric acids present various hazards and are moderately toxic and extremely irritating to skin and mucus membranes. Use these reagents in a fume hood whenever possible and if eye or skin contact occurs, flush with large volumes of water. Always wear protective clothing and safety glasses or a shield for eye protection, and observe proper mixing when working with these reagents.

- 
- 5.2 The acidification of samples containing reactive materials may result in the release of toxic gases, such as cyanides or sulfides. Acidification of samples should be done in a fume hood.
- 5.3 All personnel handling environmental samples known to contain or to have been in contact with human waste should be immunized against known disease-causative agents.
- 5.4 During atomization, the graphite tube emits intense UV radiation. Suitable precautions should be taken to protect personnel from such a hazard.
- 5.5 The use of the argon/hydrogen gas mixture during the dry and char steps may evolve a considerable amount of HCl gas. Therefore, adequate ventilation is required.

## 6.0 Apparatus, Equipment, and Supplies

---

***DISCLAIMER:** The mention of trade names or commercial products in this method is for illustrative purposes only and does not constitute endorsement or recommendation for use by the Environmental Protection Agency. Equivalent performance may be achievable using apparatus and materials other than those suggested here. The laboratory is responsible for demonstrating equivalent performance.*

---

### 6.1 Facility

- 6.1.1 Clean room—Class 100, 200 ft<sup>2</sup> minimum, with down-flow, positive-pressure ventilation, air-lock entrances, and pass-through doors.
- 6.1.1.1 Construction materials—Nonmetallic, preferably plastic sheeting attached without metal fasteners. If painted, paints that do not contain the metal(s) of interest must be used.
- 6.1.1.2 Adhesive mats, for use at entry points to control dust and dirt from shoes.
- 6.1.2 Fume hoods—Nonmetallic, two minimum, with one installed internal to the clean room.
- 6.1.3 Clean benches—Class 100, one installed in the clean room, the other adjacent to the analytical instrument(s) for preparation of samples and standards.

### 6.2 Graphite Furnace Atomic Absorbance Spectrophotometer

- 6.2.1 The GFAA spectrometer must be capable of programmed heating of the graphite tube and the associated delayed atomization device. The instrument must be equipped with an adequate background correction device capable of removing undesirable nonspecific absorbance over the spectral region of interest and provide an analytical condition not subject to the occurrence of interelement spectral overlap interferences. The furnace device must be capable of using an alternate gas supply during specified cycles of the analysis. The capability to record relatively fast (<1 second) transient signals and evaluate data on a peak area basis is preferred. In addition, a recirculating refrigeration bath is recommended for improved reproducibility of furnace temperatures.

- 6.2.2 Single element hollow cathode lamps or single element electrodeless discharge lamps along with the associated power supplies.
  - 6.2.3 Argon gas supply (high-purity grade, 99.99%) for use during the atomization of selenium, for sheathing the furnace tube when in operation, and during furnace cleanout.
  - 6.2.4 Alternate gas mixture (hydrogen 5%-argon 95%) for use as a continuous gas flow environment during the dry and char furnace cycles
  - 6.2.5 Autosampler capable of adding matrix modifier solutions to the furnace, a single addition of analyte, and completing methods of standard additions when required.
- 6.3 Preconcentration System—System containing no metal parts in the analyte flow path, configured as shown with a sample loop in Figure 1 and without a sample loop in Figure 2.

---

**NOTE:** An alternate preconcentration system to the one described below may be used if all performance criteria listed in this method can be met. If low recoveries are encountered in the preconcentration cycle for a particular analyte, it may be necessary to use an alternate preconcentration system.

---

- 6.3.1 Column—Macroporous iminodiacetate chelating resin (Dionex Metpac CC-1 or equivalent).
- 6.3.2 Control valves—Inert double stack, pneumatically operated four-way slider valves with connectors.
- 6.3.3 Argon gas supply regulated at 80-100 psi.
- 6.3.4 Solution reservoirs—Inert containers, e.g., high-density polyethylene (HDPE), for holding eluent and carrier reagents.
- 6.3.5 Tubing—High-pressure, narrow-bore, inert tubing (e.g., Tefzel ETFE or equivalent) for interconnection of pumps and valve assemblies and a minimum length for connection of the preconcentration system with the sample collection vessel.
- 6.3.6 Eluent pumping system (gradient pump)—Programmable flow, high-pressure pumping system, capable of delivering either one of three eluents at a pressure up to 2000 psi and a flow rate of 1-5 mL/min.
- 6.3.7 System setup, including sample loop (Figure 1).
  - 6.3.7.1 Sample loop—10 mL loop constructed from narrow-bore, high-pressure inert tubing, Tefzel ETFE (ethylene tetra-fluoroethylene) or equivalent.
  - 6.3.7.2 Auxiliary pumps

- 
- 6.3.7.2.1 On-line buffer pump—Piston pump (Dionex QIC pump or equivalent) for delivering 2 M ammonium acetate buffer solution.
  - 6.3.7.2.2 Carrier pump—Peristaltic pump (Gilson Minipuls or equivalent) for delivering 1% nitric acid carrier solution.
  - 6.3.7.2.3 Sample pump—Peristaltic pump for loading sample loop.
- 6.3.8 System setup without sample loop (Figure 2).
- 6.3.8.1 Auxiliary pumps
    - 6.3.8.1.1 Sample pump (Dionex QIC pump or equivalent) for loading sample on the column.
    - 6.3.8.1.2 Carrier pump (Dionex QIC pump or equivalent) used to flush collection line between samples.
- 6.4 Analytical Balance—With capability to measure to 0.1 mg, for use in weighing solids and for preparing standards.
- 6.5 Temperature Adjustable Hot Plate—Capable of maintaining a temperature of 95°C.
- 6.6 Centrifuge—With guard bowl, electric timer, and brake (optional).
- 6.7 Gravity Convection Drying Oven—With thermostatic control capable of maintaining 105°C ( $\pm 5^\circ\text{C}$ ).
- 6.8 Alkaline Detergent—Liquinox®, Alconox®, or equivalent.
- 6.9 pH meter or pH paper.
- 6.10 Labware—For determination of trace levels of elements, contamination and loss are of prime consideration. Potential contamination sources include improperly cleaned laboratory apparatus and general contamination within the laboratory environment from dust, etc. A clean laboratory work area should be designated for trace element sample handling. Sample containers can introduce positive and negative errors in the determination of trace elements by (1) contributing contaminants through surface desorption or leaching, and (2) depleting element concentrations through adsorption processes. All labware must be metal free. Suitable construction materials are fluoropolymer (FEP, PTFE), conventional or linear polyethylene, polycarbonate, and polypropylene. Fluoropolymer should be used when samples are to be analyzed for mercury. All labware should be cleaned according to the procedure in Section 11.4. Gloves, plastic wrap, storage bags, and filters may all be used new without additional cleaning unless results of the equipment blank pinpoint any of these materials as a source of contamination. In this case, either an alternate supplier must be obtained or the materials must be cleaned.

---

**NOTE:** *Chromic acid must not be used for cleaning glassware.*

---

- 6.10.1 Volumetric flasks, graduated cylinders, funnels and centrifuge tubes.
- 6.10.2 Assorted calibrated pipets.
- 6.10.3 PTFE (or other suitable material) beakers—250 mL with PTFE covers.
- 6.10.4 Narrow-mouth storage bottles—FEP (fluorinated ethylene propylene) with ETFE (ethylene tetrafluorethylene) screw closure, 125-250 mL capacities.
- 6.10.5 One-piece stem FEP wash bottle—With screw closure, 125 mL capacity.
- 6.10.6 Tongs—For removal of Apparatus from acid baths. Coated metal tongs may not be used.
- 6.10.7 Gloves—Clean, nontalc polyethylene, latex, or vinyl; various lengths. Heavy gloves should be worn when working in acid baths since baths will contain hot, strong acids.
- 6.10.8 Buckets or basins—5-50 L capacity for acid soaking of the Apparatus.
- 6.10.9 Nonmetallic brushes—For scrubbing Apparatus.
- 6.10.10 Storage bags—Clean, zip-type, nonvented, colorless polyethylene (various sizes) for storage of Apparatus.
- 6.10.11 Plastic wrap—Clean, colorless polyethylene for storage of Apparatus.
- 6.11 Sampling Equipment—The sampling team may contract with the laboratory or a cleaning facility who is responsible for cleaning, storing, and shipping all sampling devices, sample bottles, filtration equipment, and all other Apparatus used for the collection of ambient water samples. Before the equipment is shipped to the field site, the laboratory or facility must generate an acceptable equipment blank (Section 9.5.3) to demonstrate that the sampling equipment is free from contamination.
  - 6.11.1 Sampling devices—Before ambient water samples are collected, consideration should be given to the type of sample to be collected and the devices to be used (grab, surface, or subsurface samplers). The laboratory or cleaning facility must clean all devices used for sample collection. The Sampling Method describes various types of samplers. Cleaned sampling devices should be stored in polyethylene bags or wrap.
  - 6.11.2 Sample bottles—Fluoropolymer (FEP, PTFE), conventional or linear polyethylene, polycarbonate, or polypropylene; 500 mL with lids. Cleaned sample bottles should be filled with 0.1% HCl (v/v) until use.

---

**NOTE:** *If mercury is a target analyte, fluoropolymer or glass bottles must be used.*

---

6.11.3 Filtration apparatus

- 6.11.3.1 Filters, Gelman Supor 0.45  $\mu\text{m}$ , 15 mm diameter filter capsules (Gelman 12175), or equivalent.



- 6.11.3.2 Peristaltic pump—115 V a.c., 12 V d.c., internal battery, variable-speed, single-head (Cole-Parmer, portable, "Masterflex L/S," Catalog No. H-07570-10 drive with Quick Load pump head, Catalog No. H-07021-24, or equivalent).
- 6.11.3.3 Tubing for use with peristaltic pump—Styrene/ethylene/butylene/silicone (SEBS) resin, approximately 3/8 in i.d. by approx 3 ft (Cole-Parmer size 18, Catalog No. G-06464-18, or approximately 1/4 in i.d., Cole-Parmer size 17, Catalog No. G-06464-17, or equivalent). Tubing is cleaned by soaking in 5-10% HCl solution for 8-24 hours, rinsing with reagent water in a clean bench in a clean room, and drying in the clean bench by purging with metal-free air or nitrogen. After drying, the tubing is double-bagged in clear polyethylene bags, serialized with a unique number, and stored until use.

## 7.0 Reagents and Standards

Reagents may contain elemental impurities that might affect analytical data. Only high-purity reagents should be used. If the purity of a reagent is in question, analyze for contamination. All acids used for this method must be of ultra high-purity grade or equivalent. Suitable acids are available from a number of manufacturers. Redistilled acids prepared by sub-boiling distillation are acceptable.

- 7.1 Reagents for cleaning Apparatus—Sample bottle storage, and sample preservation and preparation.
- 7.1.1 Nitric acid—Concentrated (sp gr 1.41), Seastar or equivalent.
- 7.1.2 Nitric acid (1+1)—Add 500 mL concentrated nitric acid to 400 mL of reagent water and dilute to 1 L.
- 7.1.3 Nitric acid 0.75 M—Dilute 47.7 mL (67.3 g) concentrated nitric acid to 1000 mL with reagent water.
- 7.1.4 Nitric acid (1+9)—Add 100 mL concentrated nitric acid to 400 mL of reagent water and dilute to 1 L.
- 7.1.5 Hydrochloric acid—Concentrated (sp gr 1.19).
- 7.1.6 Hydrochloric acid (1+1)—Add 500 mL concentrated hydrochloric acid to 400 mL of reagent water and dilute to 1 L.
- 7.1.7 Hydrochloric acid (1+4)—Add 200 mL concentrated hydrochloric acid to 400 mL of reagent water and dilute to 1 L.
- 7.1.8 Hydrochloric acid (HCl)—1 N trace metal grade.
- 7.1.9 Hydrochloric acid (HCl)—10% wt, trace metal grade.
- 7.1.10 Hydrochloric acid (HCl)—1% wt, trace metal grade.

- 
- 7.1.11 Hydrochloric acid (HCl)—0.5% (v/v), trace metal grade.
- 7.1.12 Hydrochloric acid (HCl)—0.1% (v/v) ultrapure grade.
- 7.1.13 Acetic acid—Glacial (sp gr 1.05).
- 7.1.14 Ammonium hydroxide (20%).
- 7.1.15 Ammonium acetate buffer 1 M, pH 5.5—Add 58 mL (60.5 g) of glacial acetic acid to 600 mL of reagent water. Add 65 mL (60 g) of 20% ammonium hydroxide and mix. Check the pH of the resulting solution by withdrawing a small aliquot and testing with a calibrated pH meter, adjusting the solution to pH 5.5 ( $\pm 0.1$ ) with small volumes of acetic acid or ammonium hydroxide as necessary. Cool and dilute to 1 L with reagent water.
- 7.1.16 Ammonium acetate buffer 2 M, pH 5.5—Prepare as for Section 7.1.15 using 116 mL (121 g) glacial acetic acid and 130 mL (120 g) 20% ammonium hydroxide, diluted to 1000 mL with reagent water.
- 

**NOTE:** If the system is configured as shown in Figure 1, the ammonium acetate buffer solutions may be further purified by passing them through the chelating column at a flow rate of 5.0 mL/min. Collect the purified solution in a container. Then elute the collected contaminants from the column using 0.75 M nitric acid for five minutes at a flow rate of 4.0 mL/min. If the system is configured as shown in Figure 2, most of the buffer is being purified in an on-line configuration through the cleanup column.

---

- 7.1.17 Oxalic acid dihydrate (CASRN 6153-56-6), 0.2 M—Dissolve 25.2 g reagent grade  $C_2H_2O_4 \cdot 2H_2O$  in 250 mL reagent water and dilute to 1000 mL with reagent water.
- 

**CAUTION:** Oxalic acid is toxic; handle with care.

---

- 7.2 Reagent Water—Water demonstrated to be free from the metal(s) of interest and potentially interfering substances at the MDL for that metal listed in Table 1. Prepared by distillation, deionization, reverse osmosis, anodic/cathodic stripping voltammetry, or other technique that removes the metal(s) and potential interferent(s).
- 7.3 Matrix Modifier—Dissolve 300 mg palladium (Pd) powder in a minimum amount of concentrated  $HNO_3$  (1 mL of  $HNO_3$ , adding concentrated HCl only if necessary). Dissolve 200 mg of  $Mg(NO_3)_2 \cdot 6H_2O$  in reagent water. Pour the two solutions together and dilute to 100 mL with reagent water.
- 

**NOTE:** It is recommended that the matrix modifier be analyzed separately to assess the contribution of the modifier to the overall laboratory blank.

---

- 7.4 Standard Stock Solutions—Stock standards may be purchased or prepared from ultra high-purity grade chemicals (99.99-99.999% pure). All compounds must be dried for one hour at 105°C, unless otherwise specified. It is recommended that stock solutions be stored in FEP bottles. Replace stock standards when succeeding dilutions for preparation of calibration standards cannot be verified.
-

---

**CAUTION:** Many of these chemicals are extremely toxic if inhaled or swallowed (Section 5.1). Wash hands thoroughly after handling.

---

Below are typical stock solution preparation procedures for 1 L quantities, but for the purpose of pollution prevention, the analyst is encouraged to prepare smaller quantities when possible. Concentrations are calculated based on the weight of the pure element or the weight of the compound multiplied by the fraction of the analyte in the compound.

From pure element,

$$\text{Concentration} = \frac{\text{weight (mg)}}{\text{volume (L)}}$$

From pure compound,

$$\text{Concentration} = \frac{\text{weight (mg)} \times \text{gravimetric factor}}{\text{volume (L)}}$$

where,

gravimetric factor = the weight fraction of the analyte in the compound.

- 7.4.1 Cadmium solution, stock—1 mL = 1000 µg Cd: Dissolve 1.000 g Cd metal, acid-cleaned with (1+9) HNO<sub>3</sub>, weighed accurately to at least four significant figures, in 50 mL (1+1) HNO<sub>3</sub> with heating to effect dissolution. Let solution cool and dilute with reagent water in a 1 L volumetric flask.
- 7.4.2 Lead solution, stock—1 mL = 1000 µg Pb: Dissolve 0.1599 g PbNO<sub>3</sub> in 5 mL (1+1) nitric acid. Dilute to 100 mL with reagent water.
- 7.5 Preparation of Calibration Standards—Fresh calibration standards should be prepared every two weeks, or as needed. Dilute each stock standard solution to levels appropriate to the operating range of the instrument using reagent water containing 1% (v/v) HNO<sub>3</sub>. Calibration standards should be prepared at a minimum of three concentrations, one of which must be at the ML (Table 1), and another that must be near the upper end of the linear dynamic range. Calibration standards should be initially verified using a quality control sample (Section 7.7).
- 7.6 Blanks—The laboratory should prepare the following types of blanks. A calibration blank is used to establish the analytical calibration curve; the laboratory (method) blank is used to assess possible contamination from the sample preparation procedure and to assess spectral background, and the rinse blank is used to flush the instrument autosampler uptake system. All diluent acids should be made from concentrated acids (Section 7.1) and reagent water (Section 7.2). In addition to these blanks, the laboratory may be required to analyze field blanks (Section 9.5.2) and equipment blanks (Section 9.5.3).
- 7.6.1 Calibration blank—The calibration blank consists of 1% (v/v) HNO<sub>3</sub> in reagent water. The calibration blank should be stored in a FEP bottle.
- 7.6.2 Laboratory blank—Must contain all the reagents in the same volumes as those used in processing the samples. The laboratory blank must be carried through

the same entire preparation scheme as the samples including digestion, when applicable (Section 9.5.1).

- 7.6.3 The rinse blank is prepared as needed by adding 1.0 mL of concentrated HNO<sub>3</sub> and 1.0 mL concentrated HCl to 1 L of reagent water.
- 7.7 Quality Control Sample (QCS)—The QCS must be obtained from an outside source different from the standard stock solutions and prepared in the same acid mixture as that for the calibration standards. The concentration of the analytes in the QCS solution should be such that the resulting solution will provide an absorbance reading of approximately 0.1. The QCS solution should be stored in a FEP bottle and analyzed as needed to meet data quality needs. A fresh solution should be prepared quarterly or more frequently as needed.
- 7.8 Ongoing Precision and Recovery (OPR) Sample—The OPR should be prepared in the same acid mixture as that for the calibration standards by combining method analytes at appropriate concentrations. The OPR must be carried through the same entire preparation scheme as that for the samples including sample digestion, when applicable (Section 9.6).

## 8.0 Sample Collection, Filtration, Preservation, and Storage

- 8.1 Before an aqueous sample is collected, consideration should be given to the type of data required, (i.e., dissolved or total recoverable), so that appropriate preservation and pretreatment steps can be taken. The pH of all aqueous samples *must* be tested immediately before aliquotting for processing or direct analysis to ensure the sample has been properly preserved. If properly acid-preserved, the sample can be held up to six months before analysis.
- 8.2 Sample Collection—Samples are collected as described in the Sampling Method.
- 8.3 Sample Filtration—For dissolved metals, samples and field blanks are filtered through a 0.45 µm capsule filter at the field site. The Sampling Method describes the filtering procedures. For the determination of total recoverable elements, samples are *not* filtered but should be preserved according to the procedures in Section 8.4.
- 8.4 Sample Preservation—Preservation of samples and field blanks for both dissolved and total recoverable elements may be performed in the field when the samples are collected or in the laboratory. However, to avoid the hazards of strong acids in the field and transport restrictions, to minimize the potential for sample contamination, and to expedite field operations, the sampling team may prefer to ship the samples to the laboratory within two weeks of collection. Samples and field blanks should be preserved at the laboratory immediately when they are received. For all metals, preservation involves the addition of 10% HNO<sub>3</sub> (Section 7.1.4) to bring the sample to pH <2. For samples received at neutral pH, approx 5 mL of 10% HNO<sub>3</sub> per liter will be required.
- 8.4.1 Wearing clean gloves, remove the cap from the sample bottle, add the volume of reagent grade acid that will bring the pH to <2, and recap the bottle immediately. If the bottle is full, withdraw the necessary volume using a precleaned pipet and then add the acid. Record the volume withdrawn and the amount of acid used.

---

**NOTE:** Do not dip pH paper or a pH meter into the sample; remove a small aliquot with a clean pipet and test the aliquot. When the nature of the sample is either unknown or known to be hazardous, acidification should be done in a fume hood (Section 5.2).

---

- 8.4.2 Store the preserved sample for a minimum of 48 hours at 0-4°C to allow the acid to completely dissolve the metal(s) adsorbed on the container walls. The sample should then be verified to be pH <2 just before withdrawing an aliquot for processing or direct analysis. If for some reason such as high alkalinity the sample pH is verified to be >2, more acid must be added and the sample held for 16 hours until verified to be pH <2 (Section 8.1).
- 8.4.3 With each sample set, preserve a method blank and an OPR sample in the same way as the sample(s).
- 8.4.4 Sample bottles should be stored in polyethylene bags at 0-4°C until analysis.

## 9.0 Quality Assurance/Quality Control

- 9.1 Each laboratory that uses this method is required to operate a formal quality assurance program (Reference 19). The minimum requirements of this program consist of an initial demonstration of laboratory capability, analysis of samples spiked with metals of interest to evaluate and document data quality, and analysis of standards and blanks as tests of continued performance. To determine that results of the analysis meet the performance characteristics of the method, laboratory performance is compared to established performance criteria.
  - 9.1.1 The analyst shall make an initial demonstration of the ability to generate acceptable accuracy and precision with this method. This ability is established as described in Section 9.2.
  - 9.1.2 In recognition of advances that are occurring in analytical technology, the analyst is permitted to exercise certain options to eliminate interferences or lower the costs of measurements. These options include alternate digestion, concentration, and cleanup procedures, and changes in instrumentation. Alternate determinative techniques, such as the substitution of a colorimetric technique or changes that degrade method performance, are not allowed. If an analytical technique other than the techniques specified in the method is used, that technique must have a specificity equal to or better than the specificity of the techniques in the method for the analytes of interest.
    - 9.1.2.1 Each time the method is modified, the analyst is required to repeat the procedure in Section 9.2. If the change will affect the detection limit of the method, the laboratory is required to demonstrate that the MDL (40 CFR Part 136, Appendix B) is lower than the MDL for that analyte in this method, or one-third the regulatory compliance level, whichever is higher. If the change will affect calibration, the analyst must recalibrate the instrument according to Section 10.0.
    - 9.1.2.2 The laboratory is required to maintain records of modifications made to this method. These records include the following, at a minimum:

- 
- 9.1.2.2.1 The names, titles, addresses, and telephone numbers of the analyst(s) who performed the analyses and modification, and of the quality control officer who witnessed and will verify the analyses and modification.
- 9.1.2.2.2 A listing of metals measured, by name and CAS Registry number.
- 9.1.2.2.3 A narrative stating reason(s) for the modification(s).
- 9.1.2.2.4 Results from all quality control (QC) tests comparing the modified method to this method, including the following:
- (a) Calibration
  - (b) Calibration verification
  - (c) Initial precision and recovery (Section 9.2)
  - (d) Analysis of blanks
  - (e) Accuracy assessment
- 9.1.2.2.5 Data that will allow an independent reviewer to validate each determination by tracing the instrument output (peak height, area, or other signal) to the final result. These data are to include the following, where possible:
- (a) Sample numbers and other identifiers
  - (b) Digestion/preparation or extraction dates
  - (c) Analysis dates and times
  - (d) Analysis sequence/run chronology
  - (e) Sample weight or volume
  - (f) Volume before each extraction/concentration step
  - (g) Volume after each extraction/concentration step
  - (h) Final volume before analysis
  - (i) Injection volume
  - (j) Dilution data, differentiating between dilution of a sample or extract
  - (k) Instrument and operating conditions (make, model, revision, modifications)
  - (l) Sample introduction system (autosampler, flow injection system, etc.)
  - (m) Operating conditions (background corrections, temperature program, flow rates, etc.)
  - (n) Preconcentration system
  - (o) Detector (type, operating conditions, etc.)
  - (p) Mass spectra, printer tapes, and other recordings of raw data
  - (q) Quantitation reports, data system outputs, and other data to link raw data to results reported
- 9.1.3 Analyses of blanks are required to demonstrate freedom from contamination. Section 9.5 describes the required types, procedures, and criteria for analyzing blanks.

- 
- 9.1.4 To monitor method performance, the laboratory shall spike at least 10% of the samples with the metal(s) of interest. Section 9.3 describes this test. When results of these spikes indicate atypical method performance for samples, an alternative extraction or cleanup technique must be used to bring method performance within acceptable limits. If method performance for spikes cannot be brought within the limits in this method, the result may not be reported for regulatory compliance purposes.
- 9.1.5 The laboratory shall, on an ongoing basis, demonstrate through calibration verification and analysis of the ongoing precision and recovery aliquot that the analytical system is in control. Sections 10.8 and 9.6 describe these procedures.
- 9.1.6 The laboratory shall maintain records to define the quality of data that are generated. Section 9.3.4 describes the development of accuracy statements.
- 9.2 Initial Demonstration of Laboratory Capability
- 9.2.1 Method detection limit—To establish the ability to detect the trace metals of interest, the analyst shall determine the MDL for each analyte according to the procedure in 40 *CFR* 136, Appendix B using the apparatus, reagents, and standards that will be used in the practice of this method. The laboratory must produce an MDL that is less than or equal to the MDL listed in Table 1, or one-third the regulatory compliance limit, whichever is greater. MDLs should be determined when a new operator begins work or whenever, in the judgment of the analyst, a change in instrument hardware or operating conditions would dictate that they be redetermined.
- 9.2.2 Initial precision and recovery (IPR)—To establish the ability to generate acceptable precision and recovery, the analyst shall perform the following operations.
- 9.2.2.1 Analyze four aliquots of reagent water spiked with the metal(s) of interest at two to three times the ML (Table 1), according to the procedures in Section 12.0. All digestion, extraction, and concentration steps, and the containers, labware, and reagents that will be used with samples must be used in this test.
- 9.2.2.2 Using results of the set of four analyses, compute the average percent recovery ( $X$ ) for the metal(s) in each aliquot and the standard deviation of the recovery ( $s$ ) for each metal.
- 9.2.2.3 For each metal, compare  $s$  and  $X$  with the corresponding limits for initial precision and recovery in Table 2. If  $s$  and  $X$  for all metal(s) meet the acceptance criteria, system performance is acceptable and analysis of blanks and samples may begin. If, however, any individual  $s$  exceeds the precision limit or any individual  $X$  falls outside the range for accuracy, system performance is unacceptable for that metal. Correct the problem and repeat the test (Section 9.2.2.1).
- 9.2.3 Linear dynamic range (LDR)—The upper limit of the LDR must be established for the wavelength used for each analyte by determining the signal responses from a minimum of six different concentration standards across the range, two of

which are close to the upper limit of the LDR. Determined LDRs must be documented and kept on file. The analyst should judge the linear calibration range that may be used for the analysis of samples from the resulting data. The upper LDR limit should be an observed signal no more than 10% below the level extrapolated from the four lower standards. The LDRs should be verified whenever, in the judgment of the analyst, a change in analytical performance caused by either a change in instrument hardware or operating conditions would dictate they be redetermined.

---

**NOTE:** *Multiple cleanout furnace cycles may be necessary to fully define or utilize the LDR for certain elements such as chromium. For this reason, the upper limit of the linear calibration range may not correspond to the upper LDR limit.*

---

Determined sample analyte concentrations that exceed the upper limit of the linear calibration range must either be diluted and reanalyzed with concern for memory effects (Section 4.4.3) or analyzed by another approved method.

- 9.2.4 Quality control sample (QCS)—When beginning the use of this method, quarterly or as required to meet data quality needs, verify the calibration standards and acceptable instrument performance with the preparation and analyses of a QCS (Section 7.7). To verify the calibration standards the determined mean concentration from three analyses of the QCS must be within  $\pm 10\%$  of the stated QCS value. If the QCS is not within the required limits, an immediate second analysis of the QCS is recommended to confirm unacceptable performance. If the calibration standards, acceptable instrument performance, or both cannot be verified, the source of the problem must be identified and corrected before proceeding with further analyses.
- 9.3 Method Accuracy—To assess the performance of the method on a given sample matrix, the laboratory must perform matrix spike (MS) and matrix spike duplicate (MSD) sample analyses on 10% of the samples from each site being monitored, or at least one MS sample analysis and one MSD sample analysis must be performed for each sample batch (samples collected from the same site at the same time, to a maximum of 10 samples), whichever is more frequent. Blanks (e.g., field blanks) may not be used for MS/MSD analysis.
- 9.3.1 Determine the concentration of the MS and MSD as follows:
- 9.3.1.1 If, as in compliance monitoring, the concentration of a specific metal in the sample is being checked against a regulatory concentration limit, the spike must be at that limit or at one to five times the background concentration, whichever is greater.
- 9.3.1.2 If the concentration is not being checked against a regulatory limit, the concentration must be at one to five times the background concentration or at one to five times the ML in Table 1, whichever is greater.
- 9.3.2 Assess spike recovery
- 9.3.2.1 Determine the background concentration (B) of each metal by analyzing one sample aliquot according to the procedure in Section 12.0.



- 
- 9.3.2.2 If necessary, prepare a QC check sample concentrate that will produce the appropriate level (Section 9.3.1) in the sample when the concentrate is added.
- 9.3.2.3 Spike a second sample aliquot with the QC check sample concentrate and analyze it to determine the concentration after spiking (A) of each metal.
- 9.3.2.4 Calculate each percent recovery (P) as  $100(A-B)/T$ , where T is the known true value of the spike.
- 9.3.3 Compare the percent recovery (P) for each metal with the corresponding QC acceptance criteria found in Table 2. If any individual P falls outside the designated range for recovery, that metal has failed the acceptance criteria.
- 9.3.3.1 For a metal that has failed the acceptance criteria, analyze the ongoing precision and recovery standard (Section 9.6). If the OPR is within its respective limit for the metal(s) that failed (Table 2), the analytical system is in control and the problem is attributable to the sample matrix. This situation should be rare because of the matrix elimination preconcentration step before analysis. If a low recovery is found, check the pH of the sample plus the buffer mixture. The resulting pH should be about 5.5. The pH of the sample strongly influences the column's ability to preconcentrate the metals; therefore, a low pH may cause a low recovery.
- 9.3.3.2 For samples that show matrix problems, further isolate the metal(s) from the sample matrix using dilution, chelation, extraction, concentration, hydride generation, or other means and repeat the accuracy test (Section 9.3.2).
- 9.3.3.3 If the recovery for the metal remains outside the acceptance criteria, the analytical result for that metal in the unspiked sample is suspect and may not be reported for regulatory compliance purposes.
- 9.3.4 Assess recovery for samples and maintain records.
- 9.3.4.1 After the analysis of five samples of a given matrix type (river water, lake water, etc.) for which the metal(s) pass the tests in Section 9.3.3, compute the average percent recovery (R) and the standard deviation of the percent recovery (SR) for the metal(s). Express the accuracy assessment as a percent recovery interval from  $R-2SR$  to  $R+2SR$  for each matrix. For example, if  $R = 90\%$  and  $SR = 10\%$  for five analyses of river water, the accuracy interval is expressed as 70-110%.
- 9.3.4.2 Update the accuracy assessment for each metal in each matrix on a regular basis (e.g., after each 5-10 new measurements).
- 9.4 Precision of MS and MSD
- 9.4.1 Calculate the relative percent difference (RPD) between the MS and MSD according to the equation below using the concentrations found in the MS and MSD. Do not use the recoveries calculated in Section 9.3.2.4 for this calculation

because the RPD is inflated when the background concentration is near the spike concentration.

$$\text{RPD} = 100 \frac{(|D1-D2|)}{(D1+D2)/2}$$

where,

D1 = Concentration of the analyte in the MS sample.

D2 = Concentration of the analyte in the MSD sample.

9.4.2 The relative percent difference between the MS and the MSD must be less than 20%. If this criterion is not met, the analytical system is judged to be out of control. Correct the problem and reanalyze all samples in the sample batch associated with the MS/MSD that failed the RPD test.

9.5 Blanks—Blanks are analyzed to demonstrate freedom from contamination.

9.5.1 Laboratory (method) blank

9.5.1.1 Prepare a method blank with each sample batch (samples of the same matrix started through the sample preparation process (Section 12.0) on the same 12-hour shift, to a maximum of 10 samples). Analyze the blank immediately after analysis of the OPR (Section 9.6) to demonstrate freedom from contamination.

9.5.1.2 If the metal of interest or any potentially interfering substance is found in the blank at a concentration equal to or greater than the MDL (Table 1), sample analysis must be halted, the source of the contamination determined, the samples and a new method blank prepared, and the sample batch and fresh method blank reanalyzed.

9.5.1.3 Alternatively, if a sufficient number of blanks (three minimum) are analyzed to characterize the nature of a blank, the average concentration plus two standard deviations must be less than the regulatory compliance level.

9.5.1.4 If the result for a single blank remains above the MDL or if the result for the average concentration plus two standard deviations of three or more blanks exceeds the regulatory compliance level, results for samples associated with those blanks may not be reported for regulatory compliance purposes. Stated another way, results for all initial precision and recovery tests (Section 9.2) and all samples must be associated with an uncontaminated method blank before these results may be reported for regulatory compliance purposes.

9.5.2 Field blank

9.5.2.1 Analyze the field blank(s) shipped with each set of samples (samples collected from the same site at the same time, to a maximum of 10

- samples). Analyze the blank immediately before analyzing the samples in the batch.
- 9.5.2.2 If the metal of interest or any potentially interfering substance is found in the field blank at a concentration equal to or greater than the ML (Table 1), or greater than one-fifth the level in the associated sample, whichever is greater, results for associated samples may be the result of contamination and may not be reported for regulatory compliance purposes.
- 9.5.2.3 Alternatively, if a sufficient number of field blanks (three minimum) are analyzed to characterize the nature of the field blank, the average concentration plus two standard deviations must be less than the regulatory compliance level or less than one-half the level in the associated sample, whichever is greater.
- 9.5.2.4 If contamination of the field blanks and associated samples is known or suspected, the laboratory should communicate this to the sampling team so that the source of contamination can be identified and corrective measures taken before the next sampling event.
- 9.5.3 Equipment blanks—Before any sampling equipment is used at a given site, the laboratory or cleaning facility is required to generate equipment blanks to show that the sampling equipment is free from contamination. Two types of equipment blanks are required: bottle blanks and sampler check blanks.
- 9.5.3.1 Bottle blanks—After undergoing appropriate cleaning procedures (Section 11.4), bottles should be subjected to conditions of use to verify the effectiveness of the cleaning procedures. A representative set of sample bottles should be filled with reagent water acidified to pH <2 and allowed to stand for a minimum of 24 hours. Ideally, the time that the bottles are allowed to stand should be as close as possible to the actual time that sample will be in contact with the bottle. After standing, the water should be analyzed for any signs of contamination. If any bottle shows signs of contamination, the problem must be identified, the cleaning procedures corrected or cleaning solutions changed, and all affected bottles recleaned.
- 9.5.3.2 Sampler check blanks—Sampler check blanks are generated in the laboratory or at the equipment cleaning contractor's facility by processing reagent water through the sampling devices using the same procedures that are used in the field (see Sampling Method). Therefore, the "clean hands/dirty hands" technique used during field sampling should be followed when preparing sampler check blanks at the laboratory or cleaning facility.
- 9.5.3.2.1 Sampler check blanks are generated by filling a large carboy or other container with reagent water (Section 7.2) and processing the reagent water through the equipment using the same procedures that are used in the field (see Sampling Method). For example, manual grab sampler check blanks are collected by directly submerging a sample

bottle into the water, filling the bottle, and capping. Subsurface sampler check blanks are collected by immersing the sampler into the water and pumping water into a sample container.

9.5.3.2.2 The sampler check blank must be analyzed using the procedures in this method. If any metal of interest or any potentially interfering substance is detected in the blank, the source of contamination or interference must be identified and the problem corrected. The equipment must be shown to be free from the metal(s) of interest before the equipment may be used in the field.

9.5.3.2.3 Sampler check blanks must be run on all equipment that will be used in the field. If, for example, samples are to be collected using both a grab sampling device and a subsurface sampling device, a sampler check blank must be run on both pieces of equipment.

## 9.6 Ongoing Precision and Recovery

9.6.1 Prepare an ongoing precision and recovery sample (laboratory fortified method blank) identical to the initial precision and recovery aliquots (Section 9.2) with each sample batch (samples of the same matrix started through the sample preparation process (Section 12.0) on the same 12-hour shift, to a maximum of 10 samples) by spiking an aliquot of reagent water with the metal(s) of interest.

9.6.2 Analyze the OPR sample before analyzing the method blank and samples from the same batch.

9.6.3 Compute the percent recovery of each metal in the OPR sample.

9.6.4 For each metal, compare the concentration to the limits for ongoing recovery in Table 2. If all metals meet the acceptance criteria, system performance is acceptable and analysis of blanks and samples may proceed. If, however, any individual recovery falls outside the range given, the analytical processes are not being performed properly for that metal. Correct the problem, reprepare the sample batch, and repeat the ongoing precision and recovery test (Section 9.6).

9.6.5 Add results that pass the specifications in Section 9.6.4 to initial and previous ongoing data for each metal in each matrix. Update QC charts to form a graphic representation of continued laboratory performance. Develop a statement of laboratory accuracy for each metal in each matrix type by calculating the average percent recovery (R) and the standard deviation of percent recovery (SR). Express the accuracy as a recovery interval from  $R-2SR$  to  $R+2SR$ . For example, if  $R = 95\%$  and  $SR = 5\%$ , the accuracy is 85-105%.

9.7 The specifications in this method can be met if the instrument used is calibrated properly and then maintained in a calibrated state. A given instrument will provide the most reproducible results if dedicated to the settings and conditions required for the analyses of metals by this method.

- 9.8 Depending on specific program requirements, the laboratory may be required to analyze field duplicates collected to determine the precision of the sampling technique. The relative percent difference (RPD) between field duplicates should be less than 20%. If the RPD of the field duplicates exceeds 20%, the laboratory should communicate this to the sampling team so that the source of error can be identified and corrective measures taken before the next sampling event.

## 10.0 Calibration and Standardization

- 10.1 Table 3 lists recommended wavelengths and instrument operating conditions. However, because of differences among makes and models of spectrophotometers and electrothermal furnace devices, the actual instrument conditions selected may vary from those listed.
- 10.2 The preconcentration system can be configured using a sample loop to define the sample volume (Figure 1) or the system can be configured such that a sample pump rate and a pumping time defines the sample volume (Figure 2). The system illustrated in Figure 1 is recommended for sample sizes of <10 mL. A thorough rinsing of the sample loop between samples with HNO<sub>3</sub> is required. This rinsing will minimize the cross-contamination that may be caused by the sample loop. The system in Figure 2 should be used for sample volumes of >10 mL. The sample pump used in Figure 2 must be calibrated to ensure that a reproducible/defined volume is being delivered.
- 10.3 Before this method is used, the instrument operating conditions must be optimized. The analyst should follow the instructions provided by the manufacturer while using the conditions in Table 3 as a guide. Of particular importance is the determination of the charring temperature limit for each analyte. This limit is the furnace temperature setting at which a loss in analyte will occur before atomization. This limit should be determined by conducting char temperature profiles for each analyte and when necessary, in the matrix of question. The charring temperature selected should minimize background absorbance while providing some furnace temperature variation without loss of analyte. For routine analytical operation, the charring temperature is usually set at least 100°C below this limit. The optimum conditions selected should provide the lowest reliable MDLs and be similar to those in Table 1. Once the optimum operating conditions are determined, they should be recorded and available for daily reference.
- 10.4 Before an initial calibration, the linear dynamic range of the analyte must be determined (Section 9.2.3) using the optimized instrument operating conditions. For all determinations allow an instrument and hollow cathode lamp warm-up period of not less than 15 minutes. If an EDL is to be used, allow 30 minute for warm-up.
- 10.5 Before daily instrument calibration, inspect the graphite furnace, the sample uptake system and autosampler injector for any change that would affect instrument performance. Clean the system and replace the graphite tube, platform, or both when needed or daily. A cotton swab dipped in a 50/50 mixture of isopropyl alcohol (IPA) and H<sub>2</sub>O (so that it is damp but not dripping) can be used to remove most of the salt buildup. A second cotton swab is dipped in IPA and the contact rings are wiped down to ensure they are clean. The rings are then allowed to thoroughly dry and then a new tube is placed in the furnace and conditioned according to the instrument manufacturer's specifications.

- 10.6 After the warm-up period but before calibration, instrument stability must be demonstrated by analyzing a standard solution with a concentration three times the ML at least five times. The resulting relative standard deviation (RSD) of absorbance signals must be <5%. If the RSD is >5%, determine and correct the cause before calibrating the instrument.
- 10.7 For initial and daily operation, calibrate the instrument according to the instrument manufacturer's recommended procedures using the calibration blank (Section 7.6.1) and calibration standards (Section 7.5) prepared at three or more concentrations, one of which must be at the ML (Table 1), and another that must be near the upper end of the linear dynamic range.

- 10.7.1 Calculate the response factor (RF) for each metal in each CAL solution using the equation below and the height or area produced by the metal.

$$\text{RF} = \frac{(R_x)}{(C_x)}$$

where,

$R_x$  = Height or area of the signal for  $A_x$ .  
 $C_x$  = Concentration of compound injected ( $\mu\text{g/L}$ ).

- 10.7.2 For each metal, calculate the mean RF (M), the standard deviation of the RF (SD), and the relative standard deviation (RSD) of the mean, where  $\text{RSD} = 100 \times \text{SD}/\text{M}$ .
- 10.7.3 Linearity—If the RSD of the mean RF for any metal is less than 25% over the calibration range, an averaged response factor may be used for that analyte. Otherwise, a calibration curve for that metal must be used over the calibration range.
- 10.8 Calibration Verification—Immediately following calibration, an initial calibration verification should be performed. Adjustment of the instrument is performed until verification criteria are met. Only after these criteria are met may blanks and samples be analyzed.
- 10.8.1 Analyze the mid-point calibration standard (Section 10.7).
- 10.8.2 Compute the percent recovery of each metal using the calibration curve obtained in the initial calibration.
- 10.8.3 For each metal, compare the recovery with the corresponding limit for calibration verification in Table 2. If all metals meet the acceptance criteria, system performance is acceptable and analysis of blanks and samples may continue using the response from the initial calibration. If any individual value falls outside the range given, system performance is unacceptable for that compound. Locate and correct the problem and/or prepare a new calibration check standard and repeat the test (Sections 10.8.1 through 10.8.3), or recalibrate the system according to Section 10.7.

- 10.8.4 Calibration must be verified following every 10 samples by analyzing the mid-point calibration standard. If the recovery does not meet the acceptance criteria specified in Table 2, analysis must be halted, the problem corrected, and the instrument recalibrated. All samples after the last acceptable calibration verification must be reanalyzed.
- 10.9 A calibration blank must be analyzed following every calibration verification to show that there is no carryover of the analytes of interest and that the analytical system is free from contamination. If the concentration of an analyte in the blank result exceeds the MDL, correct the problem, verify the calibration (Section 10.8), and repeat the analysis of the calibration blank.

## 11.0 Procedures for Cleaning the Apparatus

- 11.1 All sampling equipment, sample containers, and labware should be cleaned in a designated cleaning area that has been demonstrated to be free of trace element contaminants. Such areas may include class 100 clean rooms as described by Moody (Reference 20), labware cleaning areas as described by Patterson and Settle (Reference 6), or clean benches.
- 11.2 Materials—Such as gloves (Section 6.10.7), storage bags (Section 6.10.10), and plastic wrap (Section 6.10.11), may be used new without additional cleaning unless the results of the equipment blank pinpoint any of these materials as a source of contamination. In this case, either an alternate supplier must be obtained or the materials must be cleaned.
- 11.3 Cleaning Procedures—Proper cleaning of the Apparatus is extremely important, because the Apparatus may not only contaminate the samples but may also remove the analytes of interest by adsorption onto the container surface.

---

*NOTE: If laboratory, field, and equipment blanks (Section 9.5) from an Apparatus cleaned with fewer cleaning steps than those detailed below show no levels of analytes above the MDL, those cleaning steps that do not eliminate these artifacts may be omitted if all performance criteria outlined in Section 9.0 are met.*

---

### 11.3.1 Bottles, labware, and sampling equipment

- 11.3.1.1 Fill a precleaned basin (Section 6.10.8) with a sufficient quantity of a 0.5% solution of liquid detergent (Section 6.8), and completely immerse each piece of ware. Allow to soak in the detergent for at least 30 minutes.
- 11.3.1.2 Using a pair of clean gloves (Section 6.10.7) and clean nonmetallic brushes (Section 6.10.9), thoroughly scrub down all materials with the detergent.
- 11.3.1.3 Place the scrubbed materials in a precleaned basin. Change gloves.
- 11.3.1.4 Thoroughly rinse the inside and outside of each piece with reagent water until there is no sign of detergent residue (e.g., until all soap bubbles disappear).

- 11.3.1.5 Change gloves, immerse the rinsed equipment in a hot (50-60°C) bath of concentrated reagent grade HNO<sub>3</sub> (Section 7.1.1) and allow to soak for at least two hours.
  - 11.3.1.6 After soaking, use clean gloves and tongs to remove the Apparatus and thoroughly rinse with distilled, deionized water (Section 7.2).
  - 11.3.1.7 Change gloves and immerse the Apparatus in a hot (50-60°C) bath of 1N trace metal grade HCl (Section 7.1.8), and allow to soak for at least 48 hours.
  - 11.3.1.8 Thoroughly rinse all equipment and bottles with reagent water. Proceed with Section 11.3.2 for labware and sampling equipment. Proceed with Section 11.3.3 for sample bottles.
- 11.3.2 Labware and sampling equipment
- 11.3.2.1 After cleaning, air dry in a class 100 clean air bench.
  - 11.3.2.2 After drying, wrap each piece of ware or equipment in two layers of polyethylene film.
- 11.3.3 Fluoropolymer sample bottles—These bottles should be used if mercury is a target analyte.
- 11.3.3.1 After cleaning, fill sample bottles with 0.1% (v/v) ultrapure HCl (Section 7.1.12) and cap tightly. To ensure a tight seal, it may be necessary to use a strap wrench.
  - 11.3.3.2 After capping, double bag each bottle in polyethylene zip-type bags. Store at room temperature until sample collection.
- 11.3.4 Bottles, labware, and sampling equipment—Polyethylene or material other than fluoropolymer.
- 11.3.4.1 Apply the steps outlined in Sections 11.3.1.1 through 11.3.1.8 to all bottles, labware, and sampling equipment. Proceed with Section 11.3.4.2 for bottles or Section 11.3.4.3 for labware and sampling equipment.
  - 11.3.4.2 After cleaning, fill each bottle with 0.1% (v/v) ultrapure HCl (Section 7.1.12). Double-bag each bottle in a polyethylene bag to prevent contamination of the surfaces with dust and dirt. Store at room temperature until sample collection.
  - 11.3.4.3 After rinsing labware and sampling equipment, air dry in a class 100 clean air bench. After drying, wrap each piece of ware or equipment in two layers of polyethylene film.



---

**NOTE:** Polyethylene bottles cannot be used to collect samples that will be analyzed for mercury at trace (e.g., 0.012 µg/L) levels because of the potential for vapors to diffuse through the polyethylene.

---

- 11.3.4.4 Polyethylene bags—If polyethylene bags need to be cleaned, clean according to the following procedure:
- 11.3.4.4.1 Partially fill with cold, (1+1) HNO<sub>3</sub> (Section 7.1.2) and rinse with distilled deionized water (Section 7.2).
  - 11.3.4.4.2 Dry by hanging upside down from a plastic line with a plastic clip.
- 11.3.5 Silicone tubing, fluoropolymer tubing, and other sampling apparatus—Clean any silicone, fluoropolymer, or other tubing used to collect samples by rinsing with 10% HCl (Section 7.1.9) and flushing with water from the site before sample collection.
- 11.3.6 Extension pole—Because of its length, it is impractical to submerge the 2 m polyethylene extension pole (used in with the optional grab sampling device) in acid solutions as just described. If such an extension pole is used, a nonmetallic brush (Section 6.10.9) should be used to scrub the pole with reagent water and the pole wiped down with acids described in Section 11.3.4. After cleaning, the pole should be wrapped in polyethylene film.
- 11.4 Storage—Store each piece or assembly of the Apparatus in a clean, single polyethylene zip-type bag. If shipment is required, place the bagged apparatus in a second polyethylene zip-type bag.
- 11.5 All cleaning solutions and acid baths should be periodically monitored for accumulation of metals that could lead to contamination. When levels of metals in the solutions become too high, the solutions and baths should be changed and the old solutions neutralized and discarded to comply with state and federal regulations.

## 12.0 Procedures for Sample Preparation and Analysis

### 12.1 Aqueous Sample Preparation—Dissolved analytes.

- 12.1.1 For determination of dissolved analytes in ground and surface waters, pipet an aliquot (≥20 mL) of the filtered, acid-preserved sample into a clean 50 mL polypropylene centrifuge tube. Add an appropriate volume of (1+1) nitric acid to adjust the acid concentration of the aliquot to approximate a 1% (v/v) nitric acid solution (e.g., add 0.4 mL (1+1) HNO<sub>3</sub> to a 20 mL aliquot of sample). Cap the tube and mix. The sample is now ready for analysis. Allowance for sample dilution should be made in the calculations.

---

## 12.2 Aqueous Sample Preparation—Total recoverable analytes.

---

**NOTE:** To preclude contamination during sample digestion, it may be necessary to perform the open beaker, total-recoverable digestion procedure described in Sections 12.2.1 through 12.2.6 in a fume hood that is located in a clean room. Section 12.2.7 provides an alternate digestion procedure, but the procedure has not undergone interlaboratory testing.

---

12.2.1 To determine total recoverable analytes in ambient water samples, transfer a 100 mL ( $\pm 1$  mL) aliquot from a well-mixed, acid-preserved sample to a 250 mL Griffin beaker (Section 6.10.3). If appropriate, a smaller sample volume may be used.

12.2.2 Add 2 mL (1+1) nitric acid to the beaker and place the beaker on the hot plate for digestion. The hot plate should be located in a fume hood and previously adjusted to provide evaporation at a temperature of approximately but no higher than 85°C. (See the following note.) To prevent sample contamination from the fume hood environment, the beaker should be covered or other necessary steps should be taken.

---

**NOTE:** For proper heating, adjust the temperature control of the hot plate so that an uncovered Griffin beaker containing 50 mL of water placed in the center of the hot plate can be maintained at a temperature approximately but no higher than 85°C. (Once the beaker is covered with a watch glass, the temperature of the water will rise to approximately 95°C.)

---

12.2.3 Reduce the volume of the sample aliquot to about 20 mL by gentle heating at 85°C. Do not boil. This step takes about two hours for a 100 mL aliquot with the rate of evaporation rapidly increasing as the sample volume approaches 20 mL. (A spare beaker containing 20 mL of water can be used as a gauge.)

12.2.4 Cover the lip of the beaker with a watch glass to reduce additional evaporation and gently reflux the sample for 30 minutes. (Slight boiling may occur, but vigorous boiling must be avoided to prevent loss of the HCl-H<sub>2</sub>O azeotrope.)

12.2.5 Allow the beaker to cool. Quantitatively transfer the sample solution to a 50 mL volumetric flask or 50 mL Class A stoppered graduated cylinder, make to volume with reagent water, stopper, and mix.

12.2.6 Allow any undissolved material to settle overnight, or centrifuge a portion of the prepared sample until clear. (If, after centrifuging or standing overnight, the sample contains suspended solids that would clog the nebulizer, a portion of the sample may be filtered to remove the solids before analysis. However, care should be exercised to avoid potential contamination from filtration.) The sample is now ready to be analyzed. Because the effects of various matrices on the stability of diluted samples cannot be characterized, all analyses should be performed as soon as possible after the completed preparation.

### 12.2.7 Alternate total recoverable digestion procedure

12.2.7.1 Open the preserved sample under clean conditions. Add ultrapure nitric acid at the rate of 10 mL/L. Remove the cap from the original container only long enough to add the aliquot of acid. The sample container should not be filled to the lip by the addition of the acid. However, only minimal headspace is needed to avoid leakage during heating.

12.2.7.2 Tightly recap the container and shake thoroughly. Place the container in an oven preheated to 85°C. The container should be placed on an insulating piece of material such as wood rather than directly on the typical metal grating. After the samples have reached 85°C, heat for two hours. (Total time will be two and one-half to three hours depending on the sample size). Temperature can be monitored using an identical sample container with distilled water and a thermocouple to standardize heating time.

12.2.7.3 Allow the sample to cool. The sample is now ready to be analyzed. Remove aliquots for analysis under clean conditions.

12.3 Before the preconcentration system is used for the first time, it should be thoroughly cleaned and decontaminated using 0.2 M oxalic acid.

#### 12.3.1 Precleaning the preconcentration system

12.3.1.1 Place approximately 500 mL 0.2 M oxalic acid in each of the sample/eluent containers. Flush the entire system by running the program used for sample analysis three times.

12.3.1.2 Rinse the containers with reagent water and repeat the sequence described in Section 12.2.1.1 using 0.75 M nitric acid and again using reagent water in place of the 0.2 M oxalic acid.

12.3.1.3 Rinse the containers thoroughly with reagent water, fill them with their designated reagents, and run through the program used for sample analysis to prime the pump and all eluent lines with the correct reagents.

#### 12.3.2 Peak profile determination

12.3.2.1 The peak elution time or the collection window should be determined using an ICP-AES (or Flame AA). Figure 3 is a plot of time vs emission intensity for Cd and Pb. The collection window is marked in Figure 3 and should provide about 30 seconds buffer on either side of the peak. If an ICP-AES is not available, it is recommended that the peak profile be determined by collecting 200 µL samples during the elution part of the preconcentration cycle and then reconstructing the peak profile from the analysis of the 200 µL samples.

### 12.4 Sample Preconcentration

### 12.4.1 Preconcentration using a sample loop

- 12.4.1.1 Loading sample loop—With valve 1 in the off position and valve 2 in the on position, load the sample through the sample loop to waste using the sample pump for four minutes at 4 mL/min. Switch on the carrier pump and pump 1% nitric acid to flush the sample collection line.
- 12.4.1.2 Column loading—With valve 1 in the on position, load the sample from the loop onto the column using 1 M ammonium acetate for four and one-half minutes at 4.0 mL/min. Switch on the buffer pump, and pump 2 M ammonium acetate at a flow rate of 1 mL/min. The analytes are retained on the column, and most of the matrix is passed through to waste.
- 12.4.1.3 Elution matrix—With valve 1 in the on position, the gradient pump is allowed to elute the matrix using the 1 M ammonium acetate. At this time, the carrier, buffer, and the sample pumps are all off.
- 12.4.1.4 Elute analytes—Turn off valve 1 and begin eluting the analytes by pumping 0.75 M nitric acid through the column and turn off valve 2 and pump the eluted analytes into the collection flask. The analytes should be eluted into a 2 mL sample volume.
- 12.4.1.5 Column reconditioning—Turn on valve 2 to direct the column effluent to waste, and pump 0.75 M nitric acid, 1 M ammonium acetate, 0.75 M nitric acid and 1 M ammonium acetate alternately through the column at 4.0 mL/min. Each solvent should be pumped through the column for two minutes. During this process, the next sample can be loaded into the sample loop using the sample pump.
- 12.4.1.6 Preconcentration of the sample may be achieved by running through an eluent pump program. The exact timing of this sequence should be modified according to the internal volume of the connecting tubing and the specific hardware configuration used.

### 12.4.2 Preconcentration using an auxiliary pump to determine sample volume.

- 12.4.2.1 Sample loading—With valves 1 and 2 on and the sample pump on, load the sample on the column buffering the sample using the gradient pump and the 2 M buffer. The actual sample volume is determined by knowing the sample pump rate and the time. While the sample is being loaded, the carrier pump can be used to flush the collection line.
- 12.4.2.2 Elution matrix—With valve 1 in the off position the gradient pump is allowed to elute the matrix using the 1 M ammonium acetate. At this time, the carrier, buffer, and the sample pumps are all off.

- 
- 12.4.2.3 Elution of analytes—With valves 1 and 2 in the off position the gradient pump is switched to 0.75 M HNO<sub>3</sub> and the analytes are eluted into the collection vessel. The analytes should be eluted into a 2 mL sample volume.
- 12.4.2.4 Column reconditioning—Turn on valve 2 to direct the column effluent to waste, and pump 0.75 M nitric acid, 1 M ammonium acetate, 0.75 M nitric acid and 1 M ammonium acetate alternately through the column at 4.0 mL/min.
- 

**NOTE:** When switching the gradient pump from nitric acid back to the ammonium acetate, it is necessary to flush the line connecting the gradient pump to valve 2 with the ammonium acetate before switching the valve. Otherwise, if the line contains nitric acid, it will elute the metals from the cleanup column.

---

- 12.4.2.5 Preconcentration of the sample may be achieved by running through an eluent pump program. The exact timing of this sequence should be modified according to the internal volume of the connecting tubing and the specific hardware configuration used.

## 12.5 Sample Analysis

- 12.5.1 Before beginning daily calibration, the instrument should be reconfigured to the optimized conditions as determined in Section 10. Initiate data system and allow a period of not less than 15 minutes for instrument and hollow cathode lamp warm-up. If an EDL is to be used, allow 30 minutes for warm-up. Tune and calibrate the instrument for the analytes of interest.
- 12.5.2 An autosampler must be used to introduce all solutions into the graphite furnace. Once the standard, sample or QC solution plus the matrix modifier is injected, the furnace controller completes furnace cycles and cleanout period as programmed. Analyte signals must be integrated and collected as peak area measurements. Background absorbances, background corrected analyte signals, and determined analyte concentrations on all solutions must be able to be displayed on a CRT for immediate review by the analyst and be available as hard copy for documentation to be kept on file. Flush the autosampler solution uptake system with the rinse blank (Section 7.6.3) between each solution injected.
- 12.5.3 Repeat the sequence described in Section 12.4.1 or 12.4.2 for each sample to be analyzed. At the end of the analytical run, leave the column filled with 1 M ammonium acetate buffer until it is next used.
- 12.5.4 Determined sample analyte concentrations that are  $\geq 90\%$  of the upper limit of calibration must either be diluted with acidified reagent water and reanalyzed with concern for memory effects (Section 4.4.3), or determined by another approved test procedure. Samples with a background absorbance  $> 1.0$  must be appropriately diluted with acidified reagent water and reanalyzed. If the method of standard additions is required, follow the instructions in Section 12.6.

- 12.5.5 During sample analyses, the laboratory must comply with the required quality control described in Sections 9.0 and 10.0.
- 12.6 Method of Standard Additions (MSA)—If MSA is required, the following procedure is recommended.
- 12.6.1 MSA (Reference 21) involves preparing new standards in the sample matrix by adding known amounts of standard to one or more aliquots of the processed sample solution. This technique compensates for a sample constituent that enhances or depresses the analyte signal, thus producing a different slope from that of the calibration standards. It will not correct for additive interference, which causes a baseline shift. The simplest version of this technique is the single-addition method. The procedure is as follows: Two identical aliquots of the sample solution, each of volume  $V_x$ , are taken. To the first (labeled A) is added a small volume  $V_s$  of a standard analyte solution of concentration  $C_s$ . To the second (labeled B) is added the same volume  $V_s$  of the solvent. The analytical signals of A and B are measured and corrected for nonanalyte signals. The unknown sample concentration  $C_x$  is calculated:

$$C_x = \frac{S_B V_s C_s}{(S_A - S_B) V_x}$$

where  $S_A$  and  $S_B$  are the analytical signals of solutions A and B, respectively.  $V_s$  and  $C_s$  should be chosen so that  $S_A$  is roughly twice  $S_B$  on the average. To avoid excess dilution of the sample matrix, it is best if  $V_s$  is made much less than  $V_x$ , and  $C_s$  is thus much greater than  $C_x$ . If a separation or concentration step is used, the additions are best made first and carried through the entire procedure. For the results from this technique to be valid, the following limitations must be taken into consideration:

1. The response vs amount must be linear.
2. The chemical form of the analyte added must respond in the same manner as the analyte in the sample.
3. The interference effect must be constant over the working range of concern.
4. The signal must be corrected for any additive interference.

## 13.0 Data Analysis and Calculations

- 13.1 Sample data should be reported in units of  $\mu\text{g/L}$  (parts per billion; ppb). Report results at or above the ML for metals found in samples and determined in standards. Report all results for metals found in blanks, regardless of level.
- 13.2 Compute the concentration of each analyte in the sample using the averaged RF determined from the calibration data (Section 10.7) according to the following equation:

$$C_x (\mu\text{g/L}) = \frac{R_x}{RF}$$

where,

The terms are defined in Section 10.6.1.

- 13.3 For total recoverable aqueous analytes (Sections 12.2.1 through 12.2.6), if a different aliquot volume other than 100 mL is used for sample preparation, adjust the dilution factor accordingly. Also, account for any additional dilution of the prepared sample solution needed to complete the determination of analytes exceeding the upper limit of the calibration curve. Do not report data below the determined analyte MDL concentration or below an adjusted detection limit reflecting smaller sample aliquots used in processing or additional dilutions required to complete the analysis.
- 13.4 For data values less than the ML, two significant figures should be used for reporting element concentrations. For data values greater than or equal to the ML, three significant figures should be used.
- 13.5 The QC data obtained during the analyses provide an indication of the quality of the sample data and should be provided with the sample results.

## 14.0 Method Performance

- 14.1 The MDLs in Table 1 and the quality control acceptance criteria in Table 2 were validated in two or three laboratories (Reference 22) for all dissolved analytes.

## 15.0 Pollution Prevention

- 15.1 Pollution prevention encompasses any technique that reduces or eliminates the quantity or toxicity of waste at the point of generation. Many opportunities for pollution prevention exist in laboratory operation. EPA has established a preferred hierarchy of environmental management techniques that places pollution prevention as the management option of first choice. Whenever feasible, laboratory personnel should use pollution prevention techniques to address their waste generation. When wastes cannot be feasibly reduced at the source, the Agency recommends recycling as the next best option. The acids used in this method should be reused as practicable by purifying by electrochemical techniques. The only other chemicals used in this method are the neat materials used in preparing standards. These standards are used in extremely small amounts and pose little threat to the environment when managed properly. To minimize the volume of expired standards to be disposed of, standards should be prepared in volumes consistent with laboratory use.
- 15.2 For information about pollution prevention that may be applied to laboratories and research institutions, consult *Less is Better: Laboratory Chemical Management for Waste Reduction*, available from the American Chemical Society's Department of Government Relations and Science Policy, 1155 16th Street NW, Washington DC 20036, 202/872-4477.

## 16.0 Waste Management

- 16.1 The Environmental Protection Agency requires that laboratory waste management practices be conducted consistent with all applicable rules and regulations. The Agency urges laboratories to protect the air, water, and land by minimizing and controlling all releases from hoods and bench operations, complying with the letter and spirit of any sewer discharge permits and regulations, and by complying with all solid and hazardous waste regulations, particularly the hazardous waste identification rules and land disposal restrictions. For further information on waste management consult *The Waste Management Manual for Laboratory Personnel*, available from the American Chemical Society at the address listed in Section 15.2.

## 17.0 References

1. Adeloju, S.B. and Bond, A.M. "Influence of Laboratory Environment on the Precision and Accuracy of Trace Element Analysis," *Anal. Chem.* **1985**, *57*, 1728.
2. Berman, S.S. and Yeats, P.A. "Sampling of Seawater for Trace Metals," *CRC Reviews in Analytical Chemistry* **1985**, *16*, 1.
3. Bloom, N.S. "Ultra-Clean Sampling, Storage, and Analytical Strategies for the Accurate Determination of Trace Metals in Natural Waters"; Presented at the 16th Annual EPA Conference on the Analysis of Pollutants in the Environment, Norfolk, VA, May 5, 1993.
4. Bruland, K.W. "Trace Elements in Seawater," *Chemical Oceanography* **1983**, *8*, 157.
5. Nriagu, J.O., Larson, G., Wong, H.K.T., and Azcue, J.M. "A Protocol for Minimizing Contamination in the Analysis of Trace Metals in Great Lakes Waters," *J. Great Lakes Research* **1993**, *19*, 175.
6. Patterson, C.C. and Settle, D.M. "Accuracy in Trace Analysis." In *National Bureau of Standards Special Publication 422*; LaFleur, P.D., Ed., U.S. Government Printing Office, Washington, DC, 1976.
7. Fitzgerald, W.F. and Watras, C.J. *Science of the Total Environment* **1989**, *87/88*, 223.
8. Gill, G.A. and Fitzgerald, W.F. *Deep Sea Res.* **1985**, *32*, 287.
9. Prothro, M.G. "Office of Water Policy and Technical Guidance on Interpretation and Implementation of Aquatic Life Metals Criteria," EPA Memorandum to Regional Water Management and Environmental Services Division Directors, Oct. 1, 1993.
10. "Format for Method Documentation," Distributed by the EPA Environmental Monitoring Management Council, Washington, DC, Nov. 18, 1993.
11. Siraraks, A., Kingston, H.M., and Riviello, J.M. *Anal. Chem.* **1990**, *62*, 1185.
12. Heithmar, E.M., Hinners, T.A., Rowan, J.T., and Riviello, J.M. *Anal. Chem.* **1990**, *62*, 857.
13. Windom, H.L., Byrd, J.T., Smith, R.G., Jr., and Huan, F. "Inadequacy of NASQAN Data for Assessing Metal Trends in the Nation's Rivers," *Environ. Sci. Technol.* **1991**, *25*, 1137.



14. Zief, M. and Mitchell, J.W. "Contamination Control in Trace Metals Analysis," *Chemical Analysis* **1976**, 47, Chapter 6.
15. *Carcinogens - Working With Carcinogens*, Department of Health, Education, and Welfare. Public Health Service. Centers for Disease Control. National Institute for Occupational Safety and Health Publication No. 77-206, Aug. 1977. Available from the National Technical Information Service (NTIS) as PB-277256.
16. "OSHA Safety and Health Standards, General Industry," 29 *CFR* 1910, Occupational Safety and Health Administration, OSHA 2206 (revised January 1976).
17. "Safety in Academic Chemistry Laboratories," American Chemical Society Committee on Chemical Safety, 3rd ed., 1979.
18. "Proposed OSHA Safety and Health Standards, Laboratories," Occupational Safety and Health Administration, *Fed. Regis.*, July 24, 1986.
19. *Handbook of Analytical Quality Control in Water and Wastewater Laboratories*; U.S. Environmental Protection Agency. Environmental Monitoring Systems Laboratory, Cincinnati, OH, March 1979; EPA-600/4-79-019.
20. Moody, J.R. "NBS Clean Laboratories for Trace Element Analysis," *Anal. Chem.* **1982**, 54, 1358A.
21. Winefordner, J.D. "Trace Analysis: Spectroscopic Methods for Elements," *Chemical Analysis*, 46, pp 41-42.
22. "Results of the Validation Study for Determination of Trace Metals at EPA Water Quality Criteria Levels," April 1995. Available from the Sample Control Center (operated by DynCorp), 300 N. Lee Street, Alexandria, VA 22314, 703/519-1140.

## 18.0 Glossary

Many of the terms and definitions listed below are used in the EPA 1600-series methods, but terms have been cross-referenced to terms commonly used in other methods where possible.

- 18.1 Ambient Water—Waters in the natural environment (e.g., rivers, lakes, streams, and other receiving waters), as opposed to effluent discharges.
- 18.2 Analyte—A metal tested for by the methods referenced in this method. The analytes are listed in Table 1.
- 18.3 Apparatus—The sample container and other containers, filters, filter holders, labware, tubing, pipets, and other materials and devices used for sample collection or sample preparation, and that will contact samples, blanks, or analytical standards.
- 18.4 Calibration Blank—A volume of reagent water acidified with the same acid matrix as in the calibration standards. The calibration blank is a zero standard and is used to calibrate the ICP instrument (Section 7.6.1).

- 18.5 Calibration Standard (CAL)—A solution prepared from a dilute mixed standard and/or stock solutions and used to calibrate the response of the instrument with respect to analyte concentration.
- 18.6 Dissolved Analyte—The concentration of analyte in an aqueous sample that will pass through a 0.45  $\mu\text{m}$  membrane filter assembly before sample acidification (Section 8.3).
- 18.7 Equipment Blank—An aliquot of reagent water that is subjected in the laboratory to all aspects of sample collection and analysis, including contact with all sampling devices and apparatus. The purpose of the equipment blank is to determine whether the sampling devices and apparatus for sample collection have been adequately cleaned before they were shipped to the field site. An acceptable equipment blank must be achieved before the sampling devices and apparatus are used for sample collection. In addition, equipment blanks should be run on random, representative sets of gloves, storage bags, and plastic wrap for each lot to determine whether these materials are free from contamination before use.
- 18.8 Field Blank—An aliquot of reagent water that is placed in a sample container in the laboratory, shipped to the field, and treated as a sample in all respects, including contact with the sampling devices and exposure to sampling site conditions, storage, preservation, and all analytical procedures, which may include filtration. The purpose of the field blank is to determine whether the field or sample transporting procedures and environments have contaminated the sample.
- 18.9 Field Duplicates (FD1 and FD2)—Two separate samples collected in separate sample bottles at the same time and place under identical circumstances and treated exactly the same throughout field and laboratory procedures. Analyses of FD1 and FD2 give a measure of the precision associated with sample collection, preservation, and storage, as well as with laboratory procedures.
- 18.10 Initial Precision and Recovery (IPR)—Four aliquots of the OPR standard analyzed to establish the ability to generate acceptable precision and accuracy. IPRs are performed before a method is used for the first time and any time the method or instrumentation is modified.
- 18.11 Instrument Detection Limit (IDL)—The concentration equivalent to the analyte signal which is equal to three times the standard deviation of a series of ten replicate measurements of the calibration blank signal at the selected analytical wavelength.
- 18.12 Laboratory Blank—An aliquot of reagent water that is treated exactly as a sample including exposure to all glassware, equipment, solvents, reagents, internal standards, and surrogates that are used with samples. The laboratory blank is used to determine whether method analytes or interferences are present in the laboratory environment, the reagents, or the Apparatus (Sections 7.6.2 and 9.5.1).
- 18.13 Laboratory Control Sample (LCS)—See Ongoing Precision and Recovery (OPR) Standard.
- 18.14 Laboratory Duplicates (LD1 and LD2)—Two aliquots of the same sample taken in the laboratory and analyzed separately with identical procedures. Analyses of LD1 and LD2 indicates precision associated with laboratory procedures, but not with sample collection, preservation, or storage procedures.

- 
- 18.15 Laboratory Fortified Blank (LFB)—See Ongoing Precision and Recovery (OPR) Standard.
- 18.16 Laboratory Fortified Sample Matrix (LFM)—See Matrix Spike (MS) and Matrix Spike Duplicate (MSD).
- 18.17 Laboratory Reagent Blank (LRB)—See Laboratory Blank.
- 18.18 Linear Dynamic Range (LDR)—The concentration range over which the instrument response to an analyte is linear (Section 9.2.3).
- 18.19 Matrix Modifier—A substance added to the graphite furnace along with the sample to minimize the interference effects by selective volatilization of either analyte or matrix components.
- 18.20 Matrix Spike (MS) and Matrix Spike Duplicate (MSD)—Aliquots of an environmental sample to which known quantities of the method analytes are added in the laboratory. The MS and MSD are analyzed exactly like a sample. Their purpose is to quantify the bias and precision caused by the sample matrix. The background concentrations of the analytes in the sample matrix must be determined in a separate aliquot and the measured values in the MS and MSD corrected for background concentrations (Section 9.3).
- 18.21 May—This action, activity, or procedural step is optional.
- 18.22 May Not—This action, activity, or procedural step is prohibited.
- 18.23 Method Blank—See Laboratory Blank.
- 18.24 Method Detection Limit (MDL)—The minimum concentration of an analyte that can be identified, measured, and reported with 99% confidence that the analyte concentration is greater than zero (Section 9.2.1 and Table 1).
- 18.25 Minimum Level (ML)—The lowest level at which the entire analytical system gives a recognizable signal and acceptable calibration point (Reference 9).
- 18.26 Must—This action, activity, or procedural step is required.
- 18.27 Ongoing Precision and Recovery (OPR) Standard—A laboratory blank spiked with known quantities of the method analytes. The OPR is analyzed exactly like a sample. Its purpose is to determine whether the methodology is in control and to ensure that the results produced by the laboratory remain within the method-specified limits for precision and accuracy (Sections 7.8 and 9.6).
- 18.28 Preparation Blank—See Laboratory Blank.
- 18.29 Primary Dilution Standard—A solution containing the analytes that is purchased or prepared from stock solutions and diluted as needed to prepare calibration solutions and other solutions.
- 18.30 Quality Control Sample (QCS)—A sample containing all or a subset of the method analytes at known concentrations. The QCS is obtained from a source external to the laboratory or is prepared from a source of standards different from the source of

- calibration standards. It is used to check laboratory performance with test materials prepared external to the normal preparation process.
- 18.31 Reagent Water—Water demonstrated to be free from the method analytes and potentially interfering substances at the MDL for that metal in the method.
- 18.32 Should—This action, activity, or procedural step is suggested but not required.
- 18.33 Standard Addition—The addition of a known amount of analyte to the sample to determine the relative response of the detector to an analyte within the sample matrix. The relative response is then used to assess either an operative matrix effect or the sample analyte concentration (Section 12.5).
- 18.34 Stock Standard Solution—A solution containing one or more method analytes that is prepared using a reference material traceable to EPA, the National Institute of Science and Technology (NIST), or a source that will attest to the purity and authenticity of the reference material.
- 18.35 Total Recoverable Analyte—The concentration of analyte determined by analysis of the solution extract of an unfiltered aqueous sample following digestion by refluxing with hot dilute mineral acid(s) as specified in the method (Section 12.2).

**TABLE 1. LIST OF ANALYTES AMENABLE TO ANALYSIS USING METHOD 1637: LOWEST WATER QUALITY CRITERION FOR EACH METAL SPECIES, METHOD DETECTION LIMITS, AND MINIMUM LEVELS**

Metal	Lowest EPA Water Quality Criterion (µg/L) <sup>1</sup>	Method Detection Limit (MDL) and Minimum Level (ML); µg/L	
		MDL <sup>2</sup>	ML <sup>3</sup>
Cadmium	0.37	0.0075	0.02
Lead	0.54	0.036	0.1

<sup>1</sup> Lowest of the freshwater, marine, or human health WQC at 40 *CFR* Part 131 (57 *FR* 60848 for human health criteria and 60 *FR* 22228 for aquatic criteria). Hardness-dependent freshwater aquatic life criteria also calculated to reflect a hardness of 25 mg/L CaCO<sub>3</sub>, and all aquatic life criteria adjusted to reflect dissolved levels in accordance with equations provided in 60 *FR* 22228. Hardness-dependent dissolved criteria conversion factors for Cd and Pb also calculated at a hardness of 25 mg/L per 60 *FR* 22228.

<sup>2</sup> Method Detection Limit as determined by 40 *CFR* Part 136, Appendix B.

<sup>3</sup> Minimum Level (ML) calculated by multiplying laboratory-determined MDL by 3.18 and rounding result to nearest multiple of 1, 2, 5, 10, 20, 50, etc. in accordance with procedures used by EAD and described in EPA *Draft National Guidance for the Permitting, Monitoring, and Enforcement of Water Quality-Based Effluent Limitations Set Below Analytical Detection/Quantitation Levels*, March 22, 1994.

**TABLE 2. QUALITY CONTROL ACCEPTANCE CRITERIA FOR PERFORMANCE TESTS <sup>1</sup>**

Method	Metal	Initial Precision and Recovery (Section 9.2)		Calibration Verification (Section 10.8)	Ongoing Precision and Recovery (Section 9.6)	Spike Recovery (Section 9.3)
		s	X			
1637	Cadmium	23	70–116	81–105	70–116	70–116
	Lead	27	63–117	77–103	60–120	60–120

<sup>1</sup> All specifications expressed as percent.

**TABLE 3. RECOMMENDED GRAPHITE FURNACE OPERATING CONDITIONS  
AND RECOMMENDED MATRIX MODIFIER<sup>1-3</sup>**

Element	Wavelength	Slit	Temperature (°C) <sup>4</sup>	
			Char	Atom
Cd	228.8	0.7	800	1600
Pb	283.3	0.7	1250	2000

<sup>1</sup> Matrix Modifier = 0.015 mg Pd + 0.01 mg Mg(NO<sub>3</sub>)<sub>2</sub>.

<sup>2</sup> A 5% H<sub>2</sub> in Ar gas mix is used during the dry and char steps at 300 mL/min for all elements.

<sup>3</sup> A cool-down step between the char and atomization is recommended.

<sup>4</sup> Actual char and atomization temperatures may vary from instrument to instrument and are best determined on an individual basis. The actual drying temperature may vary depending on the temperature of the water used to cool the furnace.

Figure 1 Sample Loop Configuration

	Valves		Buffer Pump	Carrier Pump	Sample Pump
	1	2			
Sample Loop Loading	Off	On	Off	On	On
Column Loading	On	On	On	Off	Off
Elution of Matrix	On	On	Off	Off	Off
Elution Of Analytes	Off	Off	Off	Off	Off
Column Recondition	Off	On	Off	Off	Off

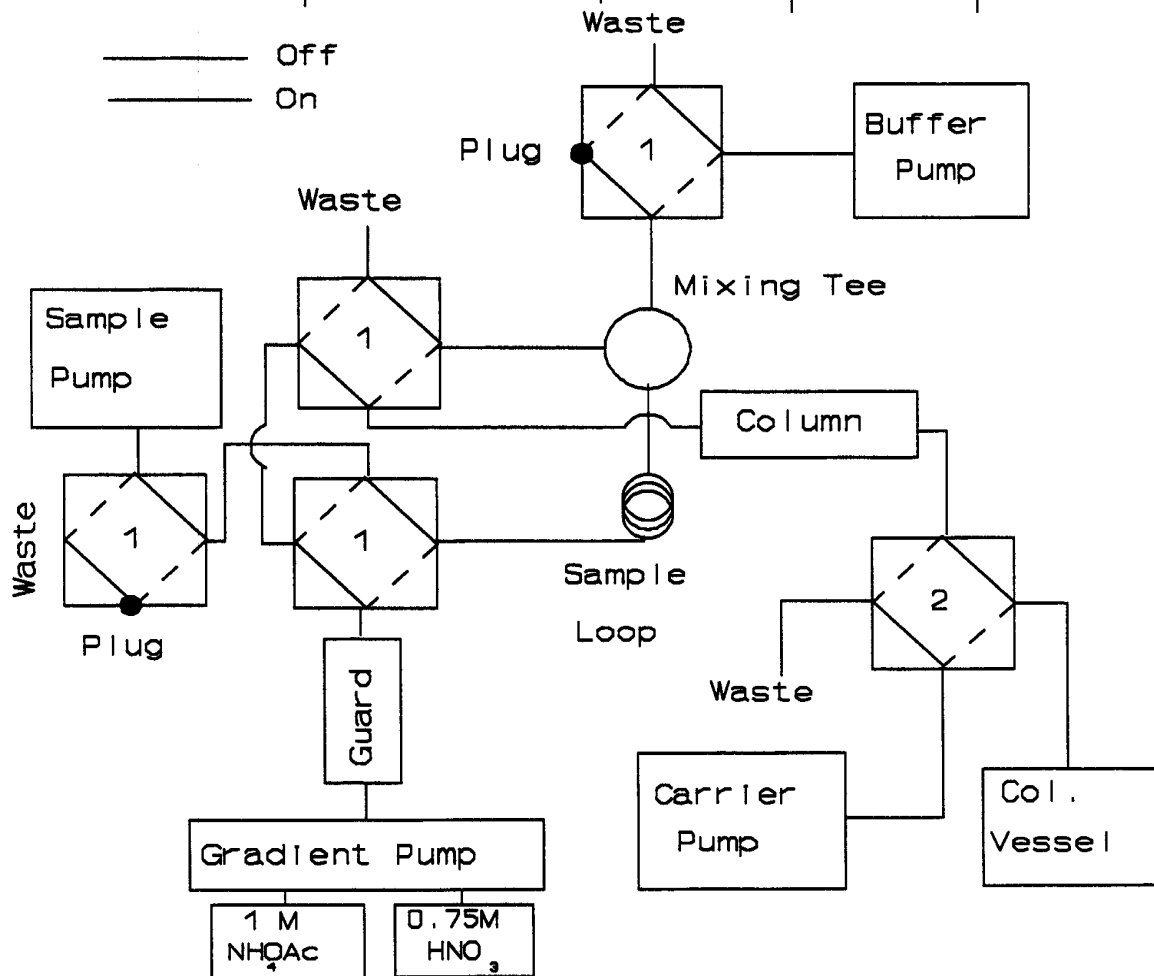

Figure 2 System Diagram Without Sample Loop

Event	Valves		Carrier Pump	Sample Pump
	1	2		
Sample Loading	On	On	On	On
Elution of Matrix	Off	On	Off	Off
Elution Of Analytes	Off	Off	Off	Off
Column Recondition	Off	On	Off	On

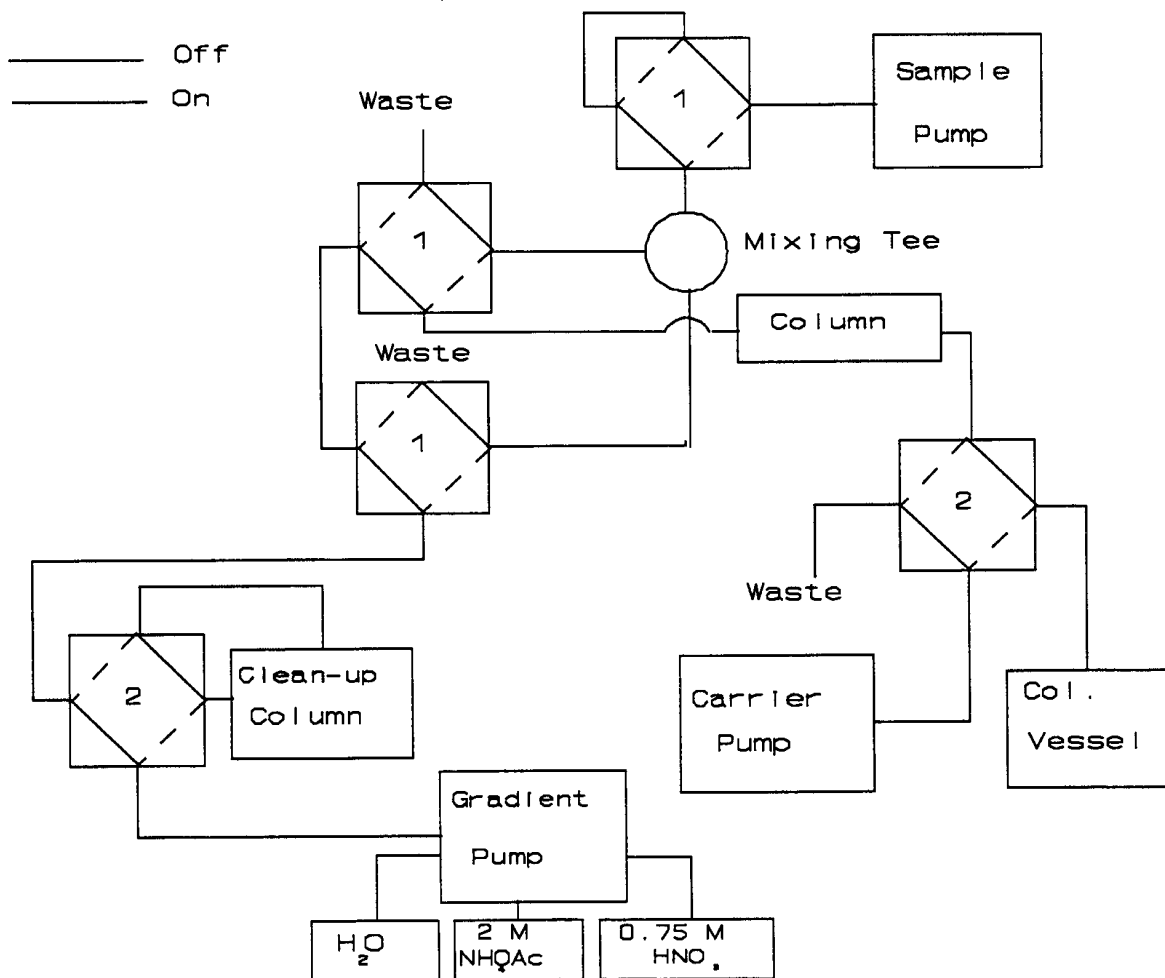



Figure 3 Peak Collection Window from ICP-AES

