

## METHOD 0050

### ISOKINETIC HCl/Cl<sub>2</sub> EMISSION SAMPLING TRAIN

#### 1.0 SCOPE AND APPLICATION

1.1 This method describes the collection of hydrogen chloride (HCl, CAS Registry Number 7647-01-0) and chlorine (Cl<sub>2</sub>, CAS Registry Number 7782-50-5) in stack gas emission samples from hazardous waste incinerators and municipal waste combustors. The collected samples are analyzed using Method 9057. This method collects the emission sample isokinetically and is therefore particularly suited for sampling at sources, such as those controlled by wet scrubbers, emitting acid particulate matter (e.g., HCl dissolved in water droplets). A midjet impinger train sampling method designed for sampling sources of HCl/Cl<sub>2</sub> emissions not in particulate form is presented in Method 0051. The method has potential for collection of all halogens and halogen acids, but has not yet been fully evaluated for that use. For analytical determination of additional halides, Method 9056 is used, rather than Method 9057.

1.2 This method is not acceptable for demonstrating compliance with HCl emission standards less than 20 ppm.

1.3 This method may also be used to collect samples for subsequent determination of particulate emissions (Method 5, see Ref. 1) following the additional sampling procedures described.

#### 2.0 SUMMARY OF METHOD

2.1 Gaseous and particulate pollutants are withdrawn from an emission source and are collected in an optional cyclone, on a filter, and in absorbing solutions. The cyclone collects any liquid droplets and is not necessary if the source emissions do not contain liquid droplets. The Teflon mat or quartz-fiber filter collects other particulate matter including chloride salts. Acidic and alkaline absorbing solutions collect gaseous HCl and Cl<sub>2</sub>, respectively. Following sampling of emissions containing liquid droplets, any HCl/Cl<sub>2</sub> dissolved in the liquid in the cyclone and/or on the filter is vaporized to gas and ultimately collected in the impingers by pulling Ascarite II<sup>R</sup> conditioned ambient air through the sampling train. In the acidified water absorbing solution, the HCl gas is solubilized and forms chloride (Cl<sup>-</sup>) ions. The Cl<sub>2</sub> gas present in the emissions has a very low solubility in acidified water and passes through to the alkaline absorbing solution where it undergoes hydrolysis to form a proton (H<sup>+</sup>), Cl<sup>-</sup>, and hypochlorous acid (HClO). The (Cl<sup>-</sup>) ions in the separate solutions are measured by ion chromatography (Method 9057). If desired, the particulate matter recovered from the filter and the probe is analyzed following the procedures in Method 5.

2.2 The stoichiometry of HCl and Cl<sub>2</sub> collection in the sampling train is as follows: In the acidified water absorbing solution, the HCl gas is solubilized and forms chloride ions (Cl<sup>-</sup>) according to the following formula:

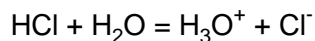

The Cl<sub>2</sub> gas present in the emissions has a very low solubility in acidified water and passes through to the alkaline absorbing solution where it undergoes hydrolysis to form a proton (H<sup>+</sup>), Cl<sup>-</sup>, and hypochlorous acid (HClO) as shown:

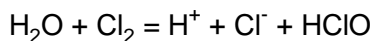

Sodium thiosulfate solution is added to the contents of the hydroxide filled impingers, in order to promote the following reaction.

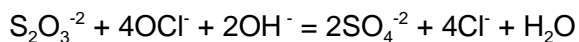

Conversion of all the original  $\text{Cl}_2$  to the stable  $\text{Cl}^-$  ion, and appropriate adjustment of the analysis calculations, removes the possibility of partial reduction of  $\text{OCl}^-$  to  $\text{Cl}^-$  and the resulting high bias to the results.

### 3.0 INTERFERENCES

3.1 Volatile materials which produce chloride ions upon dissolution during sampling are obvious interferences in the measurement of HCl. One interferant for HCl is diatomic chlorine ( $\text{Cl}_2$ ) gas which disproportionates to HCl and hypochlorous acid (HClO) upon dissolution in water.  $\text{Cl}_2$  gas exhibits a low solubility in water, however, and the use of acidic rather than neutral or basic solutions for collection of hydrogen chloride gas greatly reduces the dissolution of any chlorine present.

### 4.0 APPARATUS AND MATERIALS

#### 4.1 Sampling Train.

4.1.1 A schematic of the sampling train used in this method is shown in Figure 1. This sampling train configuration is adapted from Method 5 and Method 0010 procedures, and, as such, the majority of the required equipment is identical to that used in Method 0010 determinations. The new components required are a glass nozzle and probe, a Teflon union, a quartz-fiber or Teflon mat filter (see Section 5.5), a Teflon frit, and acidic and alkaline absorbing solutions.

4.1.2 Construction details for the basic train components are provided in Section 3.4 of EPA's Quality Assurance Handbook, Volume III (Reference 2); commercial models of this equipment are also available. Additionally, the following subsections identify allowable train configuration modifications.

4.1.3 Basic operating and maintenance procedures for the sampling train are also described in Reference 2. As correct usage is important in obtaining valid results, all users should refer to Reference 2 and adopt the operating and maintenance procedures outlined therein unless otherwise specified. The sampling train consists of the components detailed below.

4.1.3.1 Probe nozzle. Glass with sharp, tapered ( $30^\circ$  angle) leading edge. The taper shall be on the outside to preserve a constant I.D. The nozzle shall be buttonhook or elbow design. The nozzle should be coupled to the probe liner using a Teflon union. It is recommended that a stainless steel nut be used on this union. In cases where the stack temperature exceeds  $210^\circ\text{C}$  ( $410^\circ\text{F}$ ), a one-piece glass nozzle/liner assembly must be used. A range of nozzle sizes suitable for isokinetic sampling should be available. Each nozzle shall be calibrated according to the procedures outlined in Method 5.

4.1.3.2 Probe liner. Borosilicate or quartz-glass tubing with a heated system capable of maintaining a gas temperature of  $120 \pm 14^\circ\text{C}$  ( $248 \pm 25^\circ\text{F}$ ) at the exit end during sampling. Because the actual temperature at the outlet of the probe is not usually monitored during sampling, probes constructed and calibrated according to the procedure in Reference 2 are considered acceptable. Either borosilicate or quartz-glass probe liners may be used for stack temperatures up to about  $480^\circ\text{C}$  ( $900^\circ\text{F}$ ). Quartz liners shall be used for temperatures between  $480$  and  $900^\circ\text{C}$  ( $900$  and  $1650^\circ\text{F}$ ). (The softening temperature for borosilicate is  $820^\circ\text{C}$  ( $1508^\circ\text{F}$ ), and for quartz  $1500^\circ\text{C}$  ( $2732^\circ\text{F}$ .) Water-cooling of the stainless steel sheath will be necessary at temperatures approaching and exceeding  $500^\circ\text{C}$ .

4.1.3.3 Pitot tube. Type S, as described in Section 2.1 of Method 2 (Reference 1). The pitot tube shall be attached to the probe to allow constant monitoring of the stack-gas velocity. The impact (high-pressure) opening plane of the pitot tube shall be even with or above the nozzle entry plane (see Section 3.1.1 of Reference 2) during sampling. The Type S pitot tube assembly shall have a known coefficient, determined as outlined in Section 3.1.1 of Reference 2.

4.1.3.4 Differential pressure gauge. Inclined manometer or equivalent device as described in Section 2.2 of Method 2. One manometer shall be used for velocity-head ( $\Delta P$ ) readings and the other for orifice differential pressure ( $\Delta H$ ) readings.

4.1.3.5 Cyclone (optional), glass.

4.1.3.6 Filter holder. Borosilicate glass, with a Teflon frit filter support and a sealing gasket. The sealing gasket shall be constructed of Teflon or equivalent materials. The holder design shall provide a positive seal against leakage at any point along the filter circumference. The holder shall be attached immediately to the outlet of the cyclone.

4.1.3.7 Filter heating system. Any heating system capable of maintaining a temperature of  $120 \pm 14^\circ\text{C}$  ( $248 \pm 25^\circ\text{F}$ ) around the filter holder and cyclone during sampling. A temperature gauge capable of measuring temperature to within  $3^\circ\text{C}$  ( $5.4^\circ\text{F}$ ) shall be installed so that the temperature around the filter holder can be regulated and monitored during sampling.

4.1.3.8 Impinger train. The following system shall be used to determine the stack gas moisture content and to collect HCl and  $\text{Cl}_2$ : five or six impingers connected in series with leak-free ground glass fittings or any similar leak-free non-contaminating fittings. The first impinger shown in Figure 1 (knockout or condensate impinger) is optional and is recommended as a water knockout trap for use under test conditions which require such a trap. If used, this impinger should be constructed as described below for the alkaline impingers, but with a shortened stem, and should contain 50 ml of 0.05 M  $\text{H}_2\text{SO}_4$ . The following two impingers (acid impingers which each contain 100 ml of 0.05 M  $\text{H}_2\text{SO}_4$ ) shall be of the Greenburg-Smith design with the standard tip (see Method 0010, Section 4). The next two impingers (alkaline impingers which each contain 100 mL of 0.1 M NaOH) and the last impinger (containing silica gel) shall be of the Greenburg-Smith design modified

by replacing the tip with a 1.3-cm (½-in.) I.D. glass tube extending about 1.3 cm (½ in.) from the bottom of the impinger (see Method 5, Section 4).

The condensate, acid, and alkaline impingers shall contain known quantities of the appropriate absorbing reagents. The last impinger shall contain a known weight of silica gel or equivalent desiccant.

4.1.3.9 Metering system. The necessary components are a vacuum gauge, leak-free pump, thermometers capable of measuring temperature to within 3°C (5.4°F), dry-gas meter capable of measuring volume to within 1%, an orifice meter (rate meter), and related equipment, as shown in Figure 1. At a minimum, the pump should be capable of 113 m<sup>3</sup>/min (4 cfm) free flow, and the dry-gas meter should have a recording capacity of 0-28.3 m<sup>3</sup> (0-999.9 ft<sup>3</sup>) with a resolution of 0.142 liters (0.005 ft<sup>3</sup>). Other metering systems capable of maintaining sampling rates within 10% of isokineticity and of determining sample volumes to within 2% may be used. The metering system must be used in conjunction with a pitot tube to enable checks of isokinetic sampling rates.

4.1.3.10 Barometer. Mercury, aneroid, or other barometer capable of measuring atmospheric pressure to within 2.5 mm Hg (0.1 in. Hg). In many cases, the barometric reading may be obtained from a nearby National Weather Service station, in which case the station value (which is the absolute barometric pressure) is requested and an adjustment for elevation differences between the weather station and sampling point is applied at a rate of minus 2.5 mm Hg (0.1 in. Hg) per 30-m (100 ft) elevation increase (vice versa for elevation decrease).

4.1.3.11 Gas density determination equipment. Temperature sensor and pressure gauge (as described in Sections 2.3 and 2.4 of Method 2), and gas analyzer, if necessary (as described in Method 3, Reference 1). The temperature sensor ideally should be permanently attached to the pitot tube or sampling probe in a fixed configuration such that the tip of the sensor extends beyond the leading edge of the probe sheath and does not touch any metal. Alternatively, the sensor may be attached just prior to use in the field. Note, however, that if the temperature sensor is attached in the field, the sensor must be placed in an interference-free arrangement with respect to the Type S pitot tube openings (see Method 2, Figure 2-7). As a second alternative, if the stack gas is saturated, the stack temperature may be measured at a single point near the center of the stack.

4.1.3.12 Ascarite tube for conditioning ambient air. Tube tightly packed with approximately 150 g of fresh 8 to 20 mesh Ascarite II<sup>R</sup> sodium hydroxide coated silica, or equivalent, to dry and remove acid gases from the ambient air used to remove moisture from the filter and optional cyclone. The inlet and outlet ends of the tube should be packed with at least 1 cm thickness of glass wool or filter material suitable to prevent escape of Ascarite II fines. Fit one end with flexible tubing, etc. to allow connection to probe nozzle.

## 4.2 Sample Recovery.

4.2.1 Probe liner. Probe and nozzle brushes; nylon (Teflon) bristle brushes with stainless steel wire handles are required. The probe brush shall have extensions of stainless steel, Teflon, or inert material at least as long as the probe. The brushes shall be properly sized and shaped to brush out the probe liner and the probe nozzle.

4.2.2 Wash bottles. Two. Polyethylene or glass, 500 mL or larger.

4.2.3 Glass sample storage containers. Glass, 500- or 1,000-mL. Screw-cap liners shall be Teflon and constructed so as to be leak-free. Narrow-mouth glass bottles have been found to exhibit less tendency toward leakage.

4.2.4 Petri dishes. Glass or plastic sealed around the circumference with Teflon tape, for storage and transport of filter samples.

4.2.5 Graduated cylinder and/or balances. To measure condensed water to the nearest 1 mL or 1 g. Graduated cylinders shall have subdivisions not >2 mL. Laboratory triple-beam balances capable of weighing to  $\pm 0.5$  g or better are required.

4.2.6 Plastic storage containers. Screw-cap polypropylene or polyethylene containers to store silica gel.

4.2.7 Funnel and rubber policeman. To aid in transfer of silica gel to container (not necessary if silica gel is weighed in field).

4.2.8 Funnels. Glass, to aid in sample recovery.

## 5.0 REAGENTS

5.1 Reagent grade inorganic chemicals shall be used in all tests. Unless otherwise indicated, it is intended that all reagents shall conform to the specifications of the Committee on Analytical Reagents of the American Chemical Society, where such specifications are available. Other grades may be used, provided it is first ascertained that the reagent is of sufficiently high purity to permit its use without lessening the accuracy of the determination.

5.2 Reagent water. All references to water in the method refer to reagent grade water as defined in Chapter One unless otherwise specified. It is advisable to analyze a blank sample of this water prior to sampling, since the reagent blank values obtained during the field sample analysis must be less than 10 percent of the sample values.

5.3 Sulfuric acid (0.05 M),  $H_2SO_4$ . Used as the HCl absorbing reagent in the impinger train. To prepare 1 L, slowly add 2.80 mL of concentrated  $H_2SO_4$  to about 900 mL of water while stirring, and adjust the final volume to 1-L using additional water. Shake well to mix the solution. It is advisable to analyze a blank sample of this reagent prior to sampling, since the reagent blank values obtained during the field sample analysis must be less than 10 percent of the sample values.

5.4 Sodium hydroxide (0.1 M), NaOH. Used as the  $Cl_2$  absorbing reagent in the impinger train. To prepare 1 L, dissolve 4.00 g of solid NaOH in about 900 mL of water and adjust the final

volume to 1-L using additional water. Shake well to mix the solution. It is advisable to analyze a blank sample of this reagent prior to sampling, since the reagent blank values obtained during the field sample analysis must be less than 10 percent of the sample values.

5.5 Filter. Quartz-fiber or Teflon mat (e.g., Pallflex<sup>®</sup> TX40HI45) filter, or equivalent.

5.6 Silica gel. Indicating type, 6-16 mesh. If previously used, dry at 175°C (350°F) for 2 hours before using. New silica gel may be used as received. Alternatively, other types of desiccants may be used if equivalence can be demonstrated.

5.7 Acetone. When using this train for determination of particulate emissions, reagent grade acetone,  $\leq 0.001$  percent residue, in glass bottles is required. Acetone from metal containers generally has a high residue blank and should not be used. Sometimes suppliers transfer acetone to glass bottles from metal containers; thus, acetone blanks shall be run prior to field use and only acetone with low blank values ( $\leq 0.001$  percent) shall be used. In no case shall a blank value greater than 0.001 percent of the weight of acetone used be subtracted from the sample weight.

5.8 Crushed ice. Quantities ranging from 10-50 lb may be necessary during a sampling run, depending on ambient air temperature.

5.9 Screw-on connectors, Teflon sleeves on ground-glass joints, or other greaseless fittings should be used.

5.10 Sodium thiosulfate (0.5 M), Na<sub>2</sub>S<sub>2</sub>O<sub>3</sub>. Used as the reducing agent added to the sodium hydroxide filled impingers to promote the reaction given in Section 2.0. Buy premixed reagent grade, as free of chloride as possible.

## 6.0 SAMPLE COLLECTION, PRESERVATION, AND HANDLING

6.1 Sample collection is described in this method. The analytical procedures for HCl and Cl<sub>2</sub> are described in Method 9057 and for particulate matter in Method 0100.

6.2 Samples should be stored in clearly labeled, tightly sealed containers between sample recovery and analysis. They may be analyzed up to four weeks after collection.

## 7.0 PROCEDURE

7.1 Preparation for Field Test.

7.1.1 All sampling equipment shall be maintained and calibrated the procedures described in Section 3.4.2 of EPA's Quality Assurance Handbook, Volume III (Reference 2) and in Methods 1-5 (Reference 1).

7.1.2 Weigh several 200-300-g portions of silica gel in airtight containers to the nearest 0.5-g. Record on each container the total weight of the silica gel plus containers. As an alternative to preweighing the silica gel, it may instead be weighed directly in the impinger just prior to train assembly.

7.1.3 Check filters visually against light for irregularities and flaws or pinhole leaks. Label the shipping containers (glass or plastic Petri dishes) and keep the filters in these containers at all times except during sampling (and weighing for particulate analysis).

7.1.4 If a particulate determination will be conducted, desiccate the filters at  $20 \pm 5.6^\circ\text{C}$  ( $68 \pm 10^\circ\text{F}$ ) and ambient pressure for at least 24 h, and weigh at intervals of at least 6 h to a constant weight (i.e.,  $<0.5\text{-mg}$  change from previous weighing), recording results to the nearest 0.1 mg. During each weighing, the filter must not be exposed for more than a 2-min period to the laboratory atmosphere and relative humidity above 50%. Alternatively, the filters may be oven-dried at  $105^\circ\text{C}$  ( $220^\circ\text{F}$ ) for 2-3 h, desiccated for 2 h, and weighed.

## 7.2 Preliminary Field Determinations.

7.2.1 Select the sampling site and the minimum number of sampling points according to Method 1. Determine the stack pressure, temperature, and range of velocity heads using Method 2. It is recommended that a leak-check of the pitot lines (see Method 2) be performed. Determine the stack-gas moisture content using Method 4 or its alternatives to establish estimates of isokinetic sampling rate settings. Determine the stack gas dry molecular weight, as described in Method 2, Section 3. If integrated Method 3 (Reference 1) sampling is used for molecular weight determination, the integrated bag sample shall be taken simultaneously with, and for the same total length of time as the sample run.

7.2.2 Select a nozzle size based on the range of velocity heads so that it is not necessary to change the nozzle size to maintain isokinetic sampling rates. During the run, do not change the nozzle. Ensure that the proper differential pressure gauge is chosen for the range of velocity heads encountered (see Section 2 of Method 2).

7.2.3 Select a suitable probe liner and probe length so that all traverse points can be sampled. For large stacks, to reduce the length of the probe, consider sampling from opposite sides of the stack.

7.2.4 The total sampling time should be two hours. Allocate the same time to all traverse points defined by Method 1. To avoid timekeeping errors, the length of time sampled at each traverse point should be an integer or an integer plus one-half min. Size the condensate impinger for the expected moisture catch or be prepared to empty it during the run.

## 7.3 Preparation of Sampling Train.

7.3.1 Add 50 mL of 0.05 M  $\text{H}_2\text{SO}_4$  to the condensate impinger, if used. Place 100 mL of 0.05 M  $\text{H}_2\text{SO}_4$  in each of the next two impingers. Place 100 mL of 0.1 M NaOH in each of the following two impingers. It is essential that the NaOH filled impingers be maintained strongly basic throughout the sampling run. In highly acid stack environments, this may require measures such as stronger base, more volume of basic solution, or changeout of impinger liquid during the run. When in doubt, the pH of the solution should be monitored frequently or continuously. Finally, transfer approximately 200-300 g of preweighed silica gel from its container to the last impinger. More silica gel may be used, but care should be taken to ensure that it is not entrained and carried out from the impinger

during sampling. Place the silica gel container in a clean place for later use in the sample recovery. Alternatively, the weight of the silica gel plus impinger may be determined to the nearest 0.5 g and recorded.

7.3.2 Using a tweezer or clean disposable surgical gloves, place a labeled (identified) filter (weighed, if particulate matter is to be determined) in the filter holder. Be sure that the filter is properly centered and the gasket properly placed to prevent the sample gas stream from circumventing the filter. Check the filter for tears after assembly is completed.

7.3.3 To use glass liners, install the selected nozzle using a Viton-A O-ring when stack temperatures are  $<260^{\circ}\text{C}$  ( $500^{\circ}\text{F}$ ) and a woven glass fiber gasket when temperatures are higher. Other connecting systems utilizing Teflon ferrules may be used. Mark the probe with heat-resistant tape or by some other method to denote the proper distance into the stack or duct for each sampling point.

7.3.4 Set up the train as in Figure 1. Connect temperature sensors to the appropriate potentiometer/display unit. Check all temperature sensors at ambient temperature.

7.3.5 Place crushed ice around the impingers.

7.3.6 Turn on and set the filter and probe heating systems at the desired operating temperatures. Allow time for the temperatures to stabilize.

#### 7.4 Leak-check Procedures.

7.4.1 Pretest leak-check. A pretest leak-check is recommended, but not required. If the tester opts to conduct the pretest leak-check, the following procedure shall be used.

7.4.1.1 If a Viton A O-ring or other leak-free connection is used in assembling the probe nozzle to the probe liner, leak-check the train at the sampling site by plugging the nozzle and pulling a 380-mm Hg (15-in. Hg) vacuum.

NOTE: A lower vacuum may be used, provided that it is not exceeded during the test.

7.4.1.2 If a woven glass fiber gasket is used, do not connect the probe to the train during the leak-check. Instead, leak-check the train by first plugging the inlet to the cyclone, if used, or the filter holder and pulling a 380-mm Hg (15-in. Hg) vacuum (see NOTE above). Then, connect the probe to the train and leak-check at about 25-mm Hg (1-in. Hg) vacuum; alternatively, leak-check the probe with the rest of the sampling train in one step at 380-mm Hg (15-in. Hg) vacuum. Leakage rates in excess of 4% of the average sampling rate or  $0.00057\text{ m}^3/\text{min}$  (0.02 cfm), whichever is less, are unacceptable.

7.4.1.3 The following leak-check instructions for the sampling train may be helpful. Start the pump with bypass valve fully open and coarse adjust valve completely closed. Partially open the coarse adjust valve and slowly close the bypass valve until the desired vacuum is reached. Do not reverse direction of the



bypass valve; this will cause water to back up into the filter holder. If the desired vacuum is exceeded, either leak-check at this higher vacuum or end the leak-check, as shown below, and start over.

7.4.1.4 When the leak-check is completed, first slowly remove the plug from the inlet to the probe, cyclone, or filter holder and immediately turn off the vacuum pump. This prevents the liquid in the impingers from being forced backward into the filter holder and silica gel from being entrained backward into the fifth impinger.

7.4.2 Leak-checks during sample run. If, during the sampling run, a component (e.g., filter assembly or impinger) change becomes necessary or a port change is conducted, a leak-check shall be conducted immediately after the interruption of sampling and before the change is made. The leak-check shall be conducted according to the procedure outlined in Section 7.4.1, except that it shall be conducted at a vacuum greater than or equal to the maximum value recorded up to that point in the test. If the leakage rate is found to be no greater than 0.00057 m<sup>3</sup>/min (0.02 cfm) or 4% of the average sampling rate (whichever is less), the results are acceptable. If a higher leakage rate is obtained, the tester shall void the sampling run. Immediately after a component change or port change, and before sampling is reinitiated, another leak-check similar to a pre-test leak-check is recommended.

7.4.3 Post-test leak-check. A leak-check is mandatory at the conclusion of each sampling run. The leak-check shall be done using the same procedures as those with the pre-test leak-check, except that it shall be conducted at a vacuum greater than or equal to the maximum value reached during the sampling run. If the leakage rate is found to be no greater than 0.00057 m<sup>3</sup>/min (0.02 cfm) or 4% of the average sampling rate (whichever is less), the results are acceptable. If a higher leakage rate is obtained, the tester shall void the sampling run.

## 7.5 Train Operation.

7.5.1 During the sampling run, maintain an isokinetic sampling rate to within 10% of true isokinetic. Maintain a temperature around the filter and (cyclone, if used) of 120 ± 14°C (248 ± 25°F).

7.5.2 For each run, record the data required on a data sheet such as the one shown in Figure 2. Be sure to record the initial dry gas meter reading. Record the dry gas meter readings at the beginning and end of each sampling time increment, when changes in flow rates are made before and after each leak-check, and when sampling is halted. Take other readings required by Figure 2 at least once at each sample point during each time increment and additional readings when significant changes (20% variation in velocity head readings) necessitate additional adjustments in flow rate. Level and zero the manometer. Because the manometer level and zero may drift due to vibrations and temperature changes, make periodic checks during the traverse.

7.5.3 Clean the stack access ports prior to the test run to eliminate the chance of sampling deposited material. To begin sampling, remove the nozzle cap, verify that the filter and probe heating systems are at the specified temperature, and verify that the pitot tube and probe are positioned properly. Position the nozzle at the first traverse point, with the tip pointing directly into the gas stream. Immediately start the pump and adjust the flow to

isokinetic conditions using a calculator or a nomograph. Nomographs are designed for use when the Type S pitot tube coefficient is 0.84 and the stack gas equivalent density (dry molecular weight) is equal to  $29 \pm 4$ . If the stack gas molecular weight and the pitot tube coefficient are outside the above ranges, do not use the nomographs unless appropriate steps are taken to compensate for the deviations (see Reference 3).

7.5.4 When the stack is under significant negative pressure (equivalent to the height of the impinger stem), take care to close the coarse adjust valve before inserting the probe into the stack, to prevent water from backing into the filter holder. If necessary, the pump may be turned on with the coarse adjust valve closed.

7.5.5 When the probe is in position, block off the openings around the probe and stack access port to prevent unrepresentative dilution of the gas stream.

7.5.6 Traverse the stack cross section, as required by Method 1, being careful not to bump the probe nozzle into the stack walls when sampling near the walls or when removing or inserting the probe through the access port, in order to minimize the chance of extracting deposited material.

7.5.7 During the test run, make periodic adjustments to keep the temperature around the filter holder (and cyclone, if used) at the proper level. Add more ice, and, if necessary, salt to maintain a temperature of  $<20^{\circ}\text{C}$  ( $68^{\circ}\text{F}$ ) at the condenser/silica gel outlet. Also, periodically check the level and zero of the manometer.

7.5.8 If the pressure drop across the filter becomes too high, making isokinetic sampling difficult to maintain, it may be replaced in the midst of a sample run. Using another complete filter holder assembly is recommended, rather than attempting to change the filter itself. After a new filter assembly is installed, conduct a leak-check. If determined, the total particulate weight shall include the summation of all filter assembly catches.

7.5.9 If the condensate impinger becomes too full, it may be emptied, recharged with 50 mL of 0.05 M  $\text{H}_2\text{SO}_4$ , and replaced during the sample run. The condensate emptied must be saved and included in the measurement of the volume of moisture collected and included in the sample for analysis. The additional 50 mL of absorbing reagent must also be considered in calculating the moisture. After the impinger is reinstalled in the train, conduct a leak-check.

7.5.10 A single train shall be used for the entire sample run, except in cases where simultaneous sampling is required in two or more separate ducts or at two or more different locations within the same duct, or in cases where equipment failure necessitates a change of trains.

7.5.11 Note that when two or more trains are used, separate analyses of the particulate catch (if applicable) and the HCl and  $\text{Cl}_2$  impinger catches from each train shall be performed, unless identical nozzle sizes were used on all trains. In that case, the particulate catch and the HCl and  $\text{Cl}_2$  impinger catches from the individual trains may be combined, and a single particulate analysis and single HCl and  $\text{Cl}_2$  analyses of the impinger contents may be performed.

7.5.12 At the end of the sample run, turn off the coarse adjust valve, remove the probe and nozzle from the stack, turn off the pump, record the final dry gas meter reading.

7.5.13 If there is any possibility that liquid has collected in the glass cyclone and/or on the filter, connect the Ascarite tube at the probe inlet and operate the train with the filter heating system at  $120 \pm 14^\circ\text{C}$  ( $248 \pm 25^\circ\text{F}$ ) at a low flow rate (e.g.,  $\Delta H = 1$ ) sufficient to vaporize the liquid and purge any HCl in the cyclone or on the filter and pull it through the train into the impingers. After 30 minutes, turn off the flow, remove the Ascarite tube, and examine the cyclone and filter for any visible moisture. If moisture is visible, repeat this step for 15 minutes. A 45 minute cyclone purge is not effective for removing greater than 25 mL of solution from the cyclone. Also, a 45 minute purge is more effective when the filter and probe temperatures are increased to  $177^\circ\text{C}$ . (See "Laboratory Evaluation of Method 0050 for Hydrogen Chloride").

7.5.14 Conduct a post-test leak-check. Also, leak-check the pitot lines as described in Method 2. The lines must pass this leak-check in order to validate the velocity-head data.

7.5.15 If the moisture value is available, calculate percent isokineticity (see Section 7.7.10) to determine whether the run was valid or another test run should be conducted.

## 7.6 Sample Recovery

7.6.1 Allow the probe to cool. When the probe can be handled safely, wipe off all the external surfaces of the tip of the probe nozzle and place a cap over the tip. Do not cap the probe tip tightly while the sampling train is cooling down because this will create a vacuum in the filter holder, drawing water from the impingers into the holder.

7.6.2 Before moving the sampling train to the cleanup site, remove the probe and cap the open outlet, being careful not to lose any condensate that might be present. Cap the filter or cyclone inlet. Remove the umbilical cord from the last impinger and cap the impinger. If a flexible line is used between the first impinger and the filter holder, disconnect it at the filter holder and let any condensed water drain into the first impinger. Cap the filter holder outlet and the impinger inlet. Ground glass stoppers, plastic caps, serum caps, Teflon tape, Parafilm<sup>R</sup>, or aluminum foil may be used to close these openings.

7.6.3 Transfer the probe and filter/impinger assembly to the cleanup area. This area should be clean and protected from the weather to minimize sample contamination or loss.

7.6.4 Save portions of all washing solutions used for cleanup (acetone and reagent grade water) and the absorbing reagents (0.05 M  $\text{H}_2\text{SO}_4$  and 0.1 M NaOH) as blanks. Transfer 200 mL of each solution directly from the wash bottle being used (rinse solutions) or the supply container (absorbing reagents) and place each in a separate, pre-labeled glass sample container.

7.6.5 Inspect the train prior to and during disassembly and note any abnormal conditions.

7.6.6 Container No. 1 (filter catch for particulate determination). Carefully remove the filter from the filter holder and place it in its identified Petri dish container. Use one or more pair of tweezers to handle the filter. If it is necessary to fold the filter, ensure that the particulate cake is inside the fold. Carefully transfer to the Petri dish any particulate matter or filter fibers that adhere to the filter holder gasket, using a dry nylon bristle brush or sharp-edged blade, or both. Label the container and seal with Teflon tape around the circumference of the lid.

7.6.7 Container No. 2 (front-half rinse for particulate determination). Taking care that dust on the outside of the probe or other exterior surfaces does not get into the sample, quantitatively recover particulate matter or any condensate from the probe nozzle, probe fitting, probe liner, and front half of the filter holder by washing these components with acetone into a glass container. Retain an acetone blank and analyze with the samples.

7.6.8 Perform rinses as follows: carefully remove the probe nozzle and clean the inside surface by rinsing with acetone from a wash bottle and brushing with a nylon bristle brush. Brush until the rinse shows no visible particles; then make a final rinse of the inside surface with the acetone. Brush and rinse the inside parts of the Swagelok fitting with the acetone in a similar way until no visible particles remain.

7.6.9 Have two people rinse the probe liner with acetone by tilting and rotating the probe while squirting acetone into its upper end so that all inside surfaces will be wetted with solvent. Let the acetone drain from the lower end into the sample container. A glass funnel may be used to aid in transferring liquid washed to the container.

7.6.10 Follow the acetone rinse with a probe brush. Hold the probe in an inclined position and squirt acetone into the upper end while pushing the probe brush through the probe with a twisting action; place a sample container underneath the lower end of the probe and catch any acetone and particulate matter that is brushed from the probe. Run the brush through the probe three or more times until no visible particulate matter is carried out with the acetone or none remains in the probe liner on visual inspection. Rinse the brush with acetone and quantitatively collect these washings in the sample container. After the brushing, make a final acetone rinse of the probe as described above. Between sampling runs, keep brushes clean and protected from contamination.

7.6.11 Clean the inside of the front half of the filter holder and cyclone by rubbing the surfaces with a nylon bristle brush and rinsing with acetone. Rinse each surface three times, or more if needed, to remove visible particulate. Make a final rinse of the brush and filter holder. Carefully rinse out the glass cyclone and cyclone flask (if applicable). Brush and rinse any particulate material adhering to the inner surfaces of these components into the front-half rinse sample. After all rinses and particulate matter have been collected in the sample container, tighten the lid on the sample container so that acetone will not leak out when it is shipped to the laboratory. Mark the height of the fluid level to determine whether leakage occurs during transport. Label the container to identify its contents.

7.6.12 Container No. 3 (knockout and acid impinger catch for moisture and HCl determination). Disconnect the impingers. Measure the liquid in the acid and knockout impingers to within  $\pm 1$  mL by using a graduated cylinder or by weighing it to within  $\pm 0.5$  g by using a balance (if one is available). Record the volume or weight of liquid present. This

information is required to calculate the moisture content of the emission gas. Quantitatively transfer this liquid to a leak-free sample storage container. Rinse these impingers and the connecting glassware (and tubing, if used) with water, and add these rinses to the storage container. Seal the container, shake to mix, and label. The fluid level should be marked so that if any sample is lost during transport, a correction proportional to the lost volume can be applied. Retain rinse water and acidic absorbing solution blanks and analyze with the samples.

7.6.13 Container No. 4 (alkaline impinger catch for  $\text{Cl}_2$  and moisture determination). Measure and record the liquid in the alkaline impingers as described in Section 7.6.12. Quantitatively transfer this liquid to a leak-free sample storage container. Rinse these two impingers and connecting glassware with water and add these rinses to the container. Add 2 mL or more of 0.5 M  $\text{Na}_2\text{S}_2\text{O}_3$  to the sodium hydroxide ( $\text{Cl}_2$ ) samples. It is necessary to add sufficient  $\text{Na}_2\text{S}_2\text{O}_3$  to reduce the  $\text{OCl}_2$ , but too much thiosulfate may interfere with the ion chromatography analysis. The amount needed will vary with stack emission composition. In certain situations, it may be advantageous to add the  $\text{Na}_2\text{S}_2\text{O}_3$  before sampling. Consult recent references for additional suggestions. Seal the container, shake to mix, and label; mark the fluid level. Retain alkaline absorbing solution blank and analyze with the samples.

7.6.14 Container No. 5 (silica gel for moisture determination). Note the color of the indicating silica gel to determine if it has been completely spent and make a notation of its condition. Transfer the silica gel from the last impinger to its original container and seal. A funnel may make it easier to pour the silica gel without spilling. A rubber policeman may be used as an aid in removing the silica gel from the impinger. It is not necessary to remove the small amount of dust particles that may adhere strongly to the impinger wall. Because the gain in weight is to be used for moisture calculations, do not use any water or other liquids to transfer the silica gel. If a balance is available in the field, weigh the container and its contents to 0.5 g or better.

7.6.15 Prior to shipment, recheck all sample containers to ensure that the caps are well secured. Seal the lids of all containers around the circumference with Teflon tape. Ship all liquid samples upright and all particulate filters with the particulate catch facing upward.

7.7 Calculations. Retain at least one extra decimal figure beyond those contained in the available data in intermediate calculations, and round off only the final answer appropriately.

7.7.1 Nomenclature.

$A_n$  = Cross-sectional area of nozzle,  $\text{m}^2$  ( $\text{ft}^2$ ).

$B_{ws}$  = Water vapor in the gas stream, proportion by volume.

$C_a$  = Acetone blank residue concentration, mg/mg.

$C_p$  = Type S pitot tube coefficient (nominally 0.84), dimensionless.

$c_s$  = Concentration of particulate matter in stack gas, dry basis, corrected to standard conditions, g/dscm (g/dscf).

- $I$  = Percent of isokinetic sampling.
- $m_a$  = Mass of residue of acetone after evaporation, mg.
- $M_n$  = Total amount of particulate matter collected, mg.
- $M_d$  = Stack-gas dry molecular weight, g/g-mole (lb/lb-mole).
- $M_w$  = Molecular weight of water, 18.0 g/g-mole (18.0 lb/lb-mole).
- $P_{bar}$  = Barometric pressure at the sampling site, mm Hg (in. Hg).
- $P_s$  = Absolute stack-gas pressure, mm Hg (in. Hg).
- $P_{std}$  = Standard absolute pressure, 760 mm Hg (29.92 in. Hg).
- $R$  = Ideal gas constant, 0.06236 mm Hg-m<sup>3</sup>/K-g-mole (21.85 in. Hg-ft<sup>3</sup>/°R-lb-mole).
- $T_m$  = Absolute average dry-gas meter temperature (see Figure 2), K (°R).
- $T_s$  = Absolute average stack-gas temperature (see Figure 2), K (°R).
- $T_{std}$  = Standard absolute temperature, 293K (528°R).
- $V_{lc}$  = Total volume of liquid collected in the impingers and silica gel, mL.
- $V_m$  = Volume of gas sample as measured by dry-gas meter, dscm (dscf).
- $V_{m(std)}$  = Volume of gas sample measured by the dry-gas meter, corrected to standard conditions, dscm (dscf).
- $V_{w(std)}$  = Volume of water vapor in the gas sample, corrected to standard conditions, scm (scf).
- $V_s$  = Stack-gas velocity, calculated by Method 2, Equation 2-9, using data obtained from Method 5, m/sec (ft/sec).
- $W_a$  = Weight of residue in acetone wash, mg.
- $V_a$  = Volume of acetone blank, mL.
- $V_{aw}$  = Volume of acetone used in wash; mL.
- $Y$  = Dry-gas-meter calibration factor, dimensionless.
- $H$  = Average pressure differential across the orifice meter, mm H<sub>2</sub>O (in. H<sub>2</sub>O).
- $\rho_a$  = Density of acetone, mg/ml (see label on bottle).

$\rho_w$  = Density of water, 0.9982 g/mL (0.002201 lb/mL).

$\theta$  = Total sampling time, min.

13.6 = Specific gravity of mercury.

60 = Sec/min.

100 = Conversion to percent.

7.7.2 Average dry gas meter temperature and average orifice pressure drop. See data sheet (Figure 2).

7.7.3 Dry gas volume. Correct the sample measured by the dry gas meter to standard conditions (20°C, 760 mm Hg [68°F, 29.92 in. Hg]) by using Equation 1:

$$V_{m(\text{std})} = V_m Y \frac{T_{\text{std}}}{T_m} \frac{P_{\text{bar}} + \Delta H/13.6}{P_{\text{std}}} = K_1 V_m Y \frac{P_{\text{bar}} + H/13.6}{T_m} \quad (1)$$

where:  $K_1 = 0.3858$  K/mm Hg for metric units, or  
 $K_1 = 17.64^\circ\text{R/in. Hg}$  for English units.

7.7.4 Volume of water vapor.

$$V_{w(\text{std})} = V_{\text{ic}} \frac{\rho_w}{M_w} \frac{RT_{\text{std}}}{P_{\text{std}}} = K_2 V_{\text{ic}} \quad (2)$$

where:  $K_2 = 0.001333$  m<sup>3</sup>/mL for metric units, or  
 $K_2 = 0.04707$  ft<sup>3</sup>/mL for English units.

7.7.5 Moisture content.

$$B_{ws} = \frac{V_{w(\text{std})}}{V_{m(\text{std})} + V_{w(\text{std})}} \quad (3)$$

**NOTE:** In saturated or water-droplet-laden gas streams, two calculations of the moisture content of the stack gas shall be made, one from the impinger analysis (Equation 3) and a second from the assumption of saturated conditions. The lower of the two values of  $B_w$  shall be considered correct. The procedure for determining the moisture content based upon assumption of saturated conditions is given in the Note to Section 1.2 of Method 4. For the purposes of this method, the average stack gas temperature from Figure 2 may be used to make this determination, provided that the accuracy of the in-stack temperature sensor is  $\pm 1^\circ\text{C}$  ( $2^\circ\text{F}$ ).

7.7.6 Acetone blank concentration. For particulate determination.

$$C_a = \frac{m_a}{V_a \rho_a} \quad (4)$$

7.7.7 Acetone wash blank. For particulate determination.

$$W_a = C_a V_{aw} \rho_a \quad (5)$$

7.7.8 Total particulate weight. Determine the total particulate catch from the sum of the weights obtained from Container Nos. 1 and 2 less the acetone blank ( $W_a$ ).

7.7.9 Particulate concentration.

$$c_s = (0.001 \text{ g/mg})(m_n/V_{m(\text{std})}) \quad (6)$$

7.7.10 Isokinetic variation.

7.7.10.1 Calculation from raw data.

$$I = \frac{100 T_s [K_3 V_{lc} + (V_m/T_m) (P_{\text{bar}} + \Delta H/13.6)]}{60 \theta V_s P_s A_n} \quad (7)$$

where:  $K_3 = 0.003454 \text{ mm Hg}\cdot\text{m}^3/\text{mL}\cdot\text{K}$  for metric units, or  
 $K_3 = 0.002669 \text{ in. Hg}\cdot\text{ft}^3/\text{mL } ^\circ\text{R}$  for English units.

7.7.10.2 Calculation for intermediate values.

$$I = \frac{T_s V_{m(\text{std})} P_{\text{std}} 100}{T_{\text{std}} V_s \theta A_n P_s 60 (1 - B_{ws})} \quad (8)$$

$$= K_4 \frac{T_s V_{m(\text{std})}}{P_s V_s A_n \theta (1 - B_{ws})}$$

where:  $K_4 = 4.320$  for metric units, or  
 $K_4 = 0.09450$  for English units.



7.7.11 Acceptable results. If  $90\% \leq I \leq 110\%$ , the results are acceptable.

7.7.12 Analytical calculation for total  $\mu\text{g}$  HCl per sample. Calculate as described below:

$$m_{\text{HCl}} = S \times V_s \times 36.46/35.45$$

where:

$m_{\text{HCl}}$  = Mass of HCl in sample,  $\mu\text{g}$

S = Analysis of sample,  $\mu\text{g Cl}^-/\text{mL}$

$V_s$  = Volume of filtered and diluted sample, mL

36.46 = Molecular weight of HCl,  $\mu\text{g}/\mu\text{g-mole}$

35.45 = Molecular weight of  $\text{Cl}^-$ ,  $\mu\text{g}/\mu\text{g-mole}$

7.7.13 Analytical calculation for total  $\mu\text{g}$   $\text{Cl}_2$  per sample. Calculate as described below:

$$m_{\text{Cl}_2} = S \times V_2$$

where:

$V_2$  = Volume of filtered and diluted sample, mL

S = Analysis of sample,  $\mu\text{g Cl}^-/\text{mL}$

$m_{\text{Cl}_2}$  = Mass of  $\text{Cl}_2$  in sample,  $\mu\text{g}$

7.7.14 Concentration of HCl in the flue gas. Calculate as described below:

$$C = K \times m/V_{m(\text{std})}$$

where:

C = Concentration of HCl or  $\text{Cl}_2$ , dry basis,  $\text{mg}/\text{dscm}$ ,

$K = 10^{-3}$   $\text{mg}/\mu\text{g}$ ,

m = Mass of HCl or  $\text{Cl}_2$  in sample,  $\mu\text{g}$ , and

$V_{m(\text{std})}$  = Dry gas volume measured by the dry gas meter, corrected to standard conditions,  $\text{dscm}$ .

## 8.0 QUALITY CONTROL

8.1 Sampling. See EPA Manual 600/4-77-027b for Method 5 quality control.

8.2 Analysis. At the present time, a validated audit material does not exist for this method. Analytical quality control procedures are detailed in Method 9057.

8.3 Quality control check sample. Chloride solutions of reliably known concentrations are available for purchase from the National Institute of Standards and Technology (SRM 3182). The QC check sample should be prepared in the appropriate absorbing reagent at a concentration approximately equal to the mid range calibration standard. The quality control check sample should be injected in duplicate immediately after the calibration standards have been injected the first time.

The Cl<sup>-</sup> value obtained for the check sample using the final calibration curve should be within 10 percent of the known value for the check sample.

## 9.0 METHOD PERFORMANCE

9.1 The in-stack limit for HCl for the method is approximately 0.02 mg/dscm of stack gas. The method has a negative bias below 20 ppm HCl (Reference 6).

9.2 It is preferable to include the cyclone in the sampling train to protect the filter from any moisture present. There is research in progress regarding the necessity of the cyclone at low moisture sources and the use of Ascarite II in the drying procedure (Section 7.5.12).

9.3 The lower detection limit of the analytical method is 0.1 ug of Cl<sup>-</sup> per mL of sample solution. Samples with concentrations which exceed the linear range of the IC may be diluted.

9.4 The precision and bias for analysis of HCl using this analytical protocol have been measured in combination with the midget impinger HCl/Cl<sub>2</sub> train (Method 0051) for sample collection. The laboratory relative standard deviation is within 6.2 percent and 3.2 percent at HCl concentrations of 3.9 and 15.3 ppm, respectively. The method does not exhibit any bias for HCl when sampling at Cl<sub>2</sub> concentrations less than 50 ppm.

## 10.0 REFERENCES

1. U. S. Environmental Protection Agency, 40 CFR Part 60, Appendix A, Methods 1-5.
2. U. S. Environmental Protection Agency, "Quality Assurance Handbook for Air Pollution Measurement Systems, Volume III, Stationary Source Specific Methods," Publication No. EPA-600/4-77-027b, August 1977.
3. Shigehara, R. T., Adjustments in the EPA Nomography for Different Pitot Tube Coefficients and Dry Molecular Weights, Stack Sampling News, 2:4-11 (October 1974).
4. Steinsberger, S. C. and J. H. Margeson, "Laboratory and Field Evaluation of a Methodology for Determination of Hydrogen Chloride Emissions from Municipal and Hazardous Waste Incinerators," U. S. Environmental Protection Agency, Office of Research and Development, Report No. 600/3/89/064, April, 1989. Available from NTIS.
5. State of California, Air Resources Board, Method 421, "Determination of Hydrochloric Acid Emissions from Stationary Sources," March 18, 1987.
6. Entropy Environmentalists, Inc., "Laboratory Evaluation of a Sampling and Analysis Method for Hydrogen Chloride Emissions from Stationary Sources: Interim Report," EPA Contract No. 68-02-4442, Research Triangle Park, North Carolina, January 22, 1988.
7. Steger, J.L.; Wagoner, D.E.; Bursey, J.T.; Merrill, R.G.; Fuerst, R.G. and Johnson, L.D. "Laboratory Evaluation of Method 0050 for Hydrogen Chloride," Proceedings of the 13th Annual International Incineration Conference, Houston, TX, May 1994.

8. Johnson, L.D., "Stack Sampling Methods for Halogens and Halogen Acids," presented at EPA/A&WMA International Symposium: Measurement of Toxic and Related Air Pollutants, Research Triangle Park, NC, May 1996.

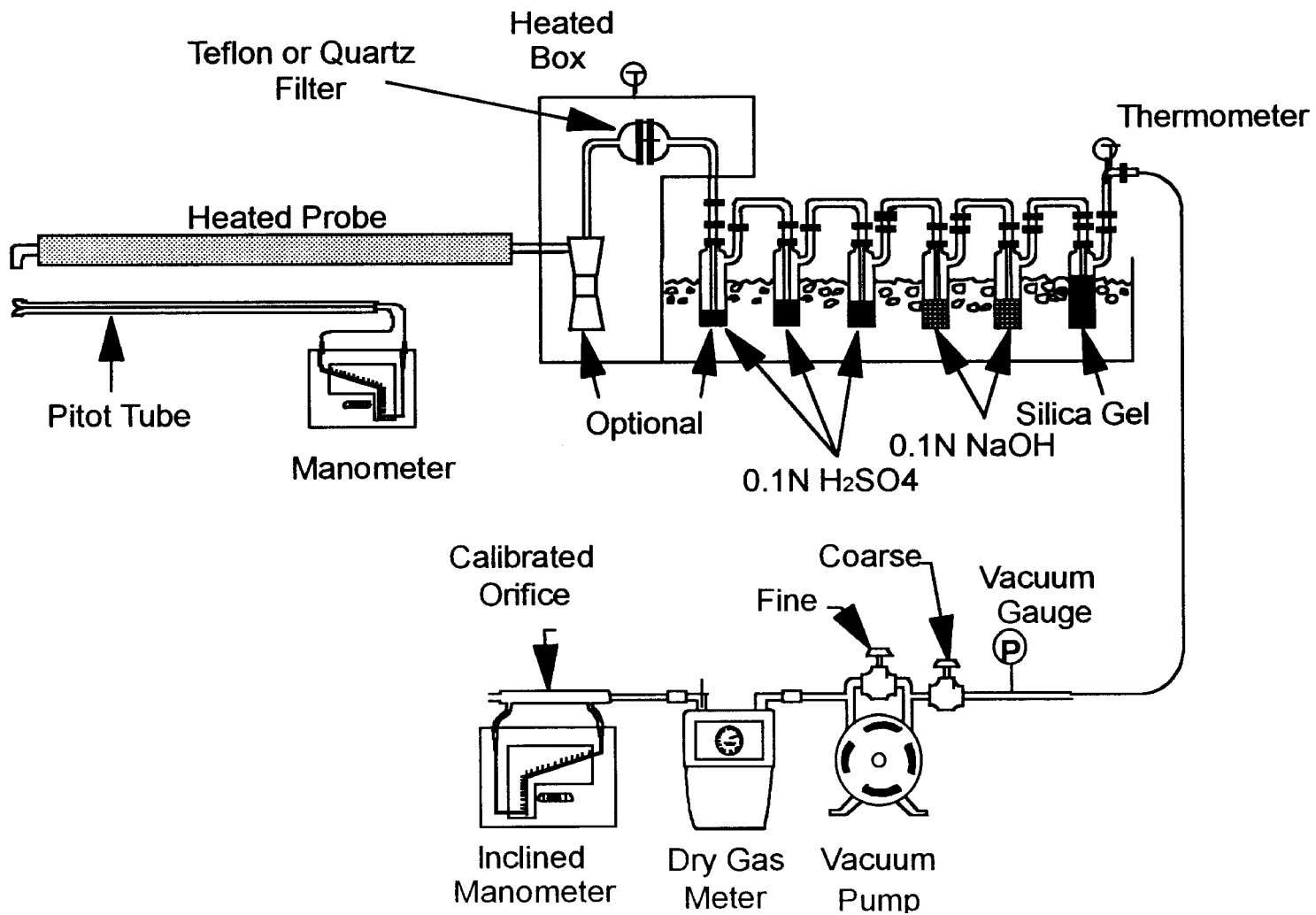
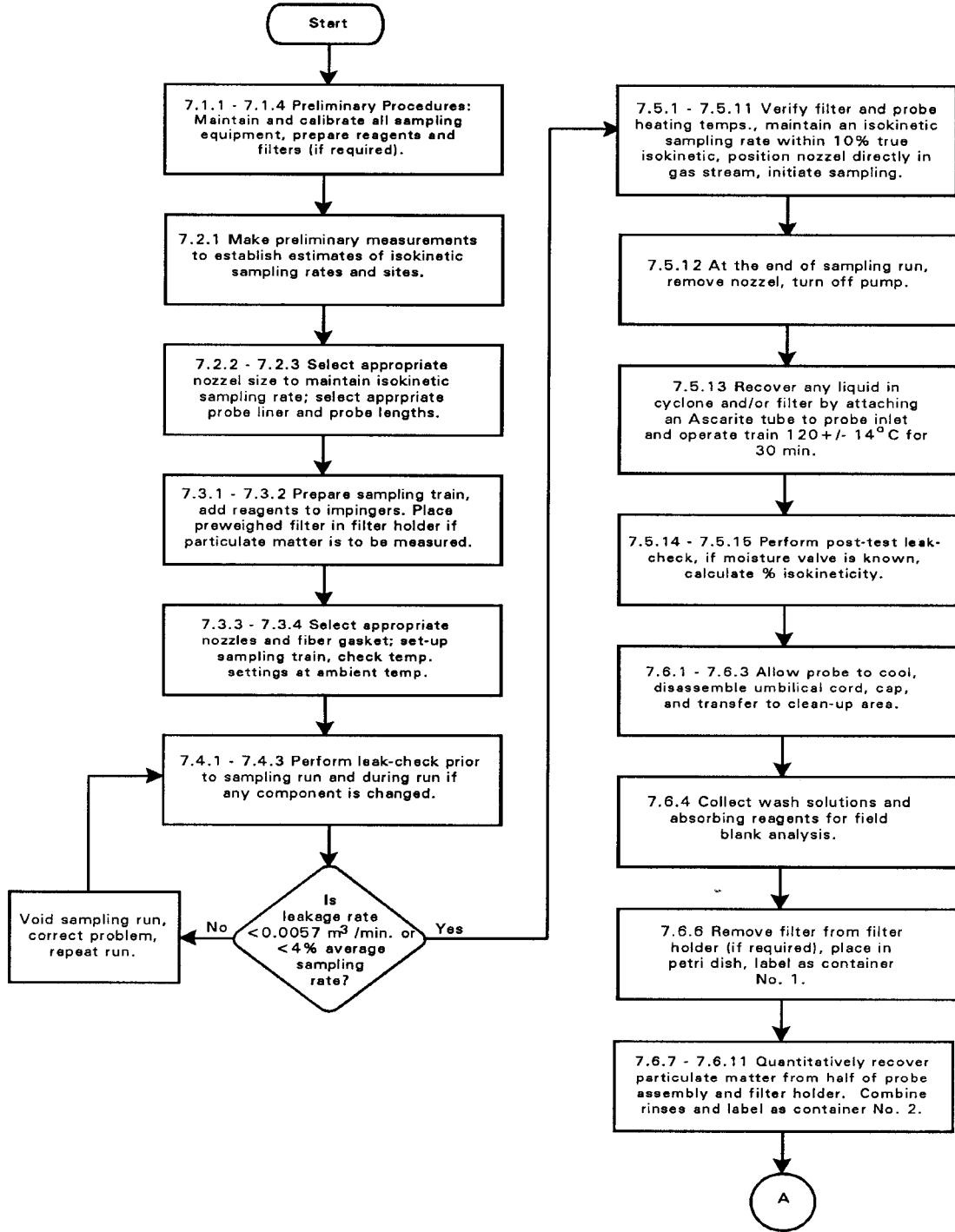

FIGURE 1. ISOKINETIC HCl/Cl<sub>2</sub> SAMPLING TRAIN.



METHOD 0050  
ISOKINETIC HCl/C<sub>l</sub><sub>2</sub> EMISSION SAMPLING TRAIN



METHOD 0050  
ISOKINETIC HCl/Cl<sub>2</sub> EMISSION SAMPLING TRAIN  
(Cont.)

