U.S. EPA Proposes to Reopen Title V Air Permit

Veolia ES Technical Solutions Air Permit

Sauget, Illinois

February 2013

What can you do?

- **Submit written comments** to U.S. EPA regarding the draft permit during the comment period that runs from **Jan. 8 to April 1, 2013**. Comments should include factual grounds and supporting material or references.
- **Attend the public hearing** on **Feb. 19, 2013**, at the Southern Illinois University Edwardsville – East St. Louis Higher Education Campus, Distance Learning Lab, Room 2083, Building B, 601 James R. Thompson Blvd., East St. Louis, from 3 p.m. to 7 p.m. *See more details on the comment period and meeting on the back page.*
- **Go on a tour.** Veolia will be offering facility tours. To arrange a tour contact Doug Harris or Dennis Warchol at 618-271-2804.
- **Review the statement of basis and draft permit.** The *statement of basis* provides more information and explains the legal and factual bases for the permit conditions. The draft Title V permit includes all of the requirements the source is legally obligated to follow. Only portions of the permit that are being changed because of the proposed action are currently open for comment during the comment period. *See Page 3 for locations where you can view these documents.*

The U.S. Environmental Protection Agency is proposing to reopen a Clean Air Act permit for a hazardous waste combusting facility in southern Illinois. U.S. EPA is undertaking this permit action for Veolia ES Technical Solutions LLC., 7 Mobile Ave., Sauget, Ill., near St. Louis, to modify its Clean Air Act Title V operating permit. The revised permit would include “feedrate” limits for certain heavy metals. Feedrate limits are the maximum amount of heavy metals Veolia can feed into the incinerator combustion unit per hour. The heavy metals include mercury, arsenic and lead. The permit also would include additional requirements for monitoring the waste incinerated by Veolia at the facility.

U.S. EPA has based the proposed feedrate limits, which comply with applicable regulations, on available performance test data. Veolia will continue operating the combustors following the requirements of their current permit until a final revised permit is issued. U.S. EPA will not issue a final permit until after the public has a chance to comment. See the left-hand box and read Page 3 for information about the public participation process for this proposed permit.

Background

The Clean Air Act requires certain sources that emit large amounts of air pollution to obtain an operating permit, also known as a Title V permit, after the source has begun to operate. This permit is designed to improve compliance by clarifying what facilities must do to control air pollution.

For this permitting action U.S. EPA is the permitting authority. U.S. EPA issued the initial Title V permit to Veolia on September 12, 2008. U.S. EPA is now proposing to reopen the permit to incorporate feedrate limits and monitoring requirements so that the permit complies with the Clean Air Act. Only those portions of the permit that U.S. EPA is proposing to change are open for public comment at this time. The federal Agency expects the facility to submit an application for a permit renewal in 2013 and will open the entire permit comment at that time.

Burning hazardous waste

Specially designed incinerators, boilers, and industrial furnaces can burn hazardous waste. Hazardous waste – which is toxic, flammable, corrosive or reacts with other materials – can be produced by businesses or manufacturing operations. Burning hazardous waste is one way to safely manage it. Burning reduces waste volume by converting solids and liquids to ash while destroying toxic organic compounds. In addition, disposal of the ash in a landfill is safer and more efficient than disposal of untreated hazardous waste. The ash generated from hazardous waste combustion must be tested, and, if found to be hazardous, must be treated for remaining toxicity before it is disposed of in a landfill.

Continued on P. 2 ...

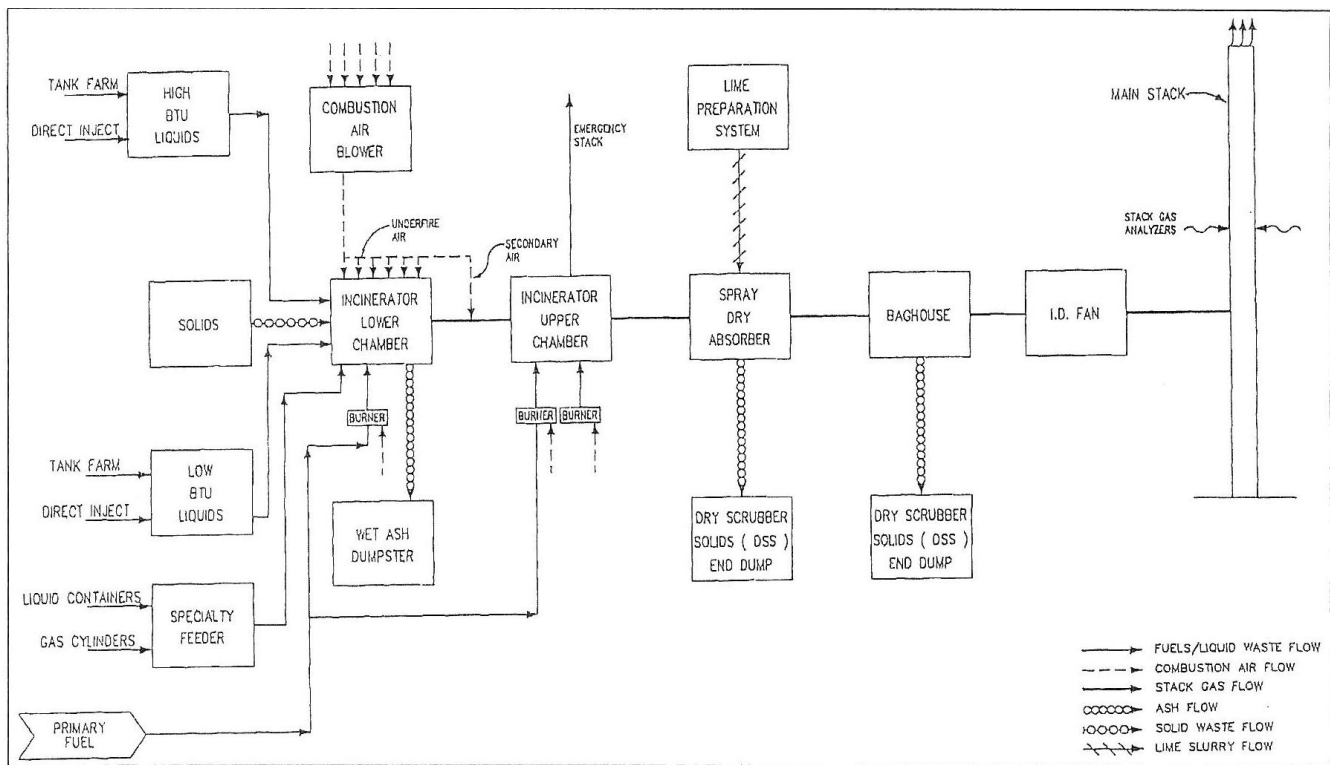

This diagram shows the combustion process of Unit # 2. The combustion processes of Units 3 and 4 are slightly different, but follow similar principals.

Veolia has three hazardous waste combustors: #2, #3, and #4 (#1 was closed in 1992). Veolia receives hazardous waste in both liquid and solid forms. Liquid waste may be stored in a tank farm prior to being burned. Gases occasionally escape from the tanks, and carbon adsorption units are attached to each tank to help control these emissions. Bulk solid wastes are stored in four pits in a building prior to combustion. The structure is maintained at negative pressure so emissions don't escape. Before the waste is burned it is packaged into more manageable containers and any liquids are absorbed.

Each combustor has a primary and secondary combustion chamber that includes natural gas-fired auxiliary burners used during startup, shutdown, malfunctions and for additional heat input. The combustors are also connected to spray dryer absorbers and a baghouse, which help to control air pollution. Combustor #4 also has a tempering chamber and activated carbon injection to further help control air pollution. Emissions are constantly monitored for carbon monoxide and hydrogen chloride.

The combustors are supported by a lime handling system and an ash handling system. The lime handling system supports the spray dry absorber, as lime is an important material in this air pollution control technology. The ash handling system ensures that ash produced during the combustion process is collected and properly disposed of.

Pollutants affected by the permit

The proposed permit action sets feedrate limits for mercury, semi-volatile metals such as cadmium and lead, and low-volatile metals such as arsenic, beryllium, and chromium. Volatility is a measure of how readily a substance changes from a solid or liquid to a vapor. These pollutants have known negative health effects. U.S. EPA is setting feedrate limits in this action that comply with applicable federal regulations. More detail about each of these pollutants can be found in the statement of basis. Information on how to review the statement of basis is found on the last page of this fact sheet.

Setting the limits

The heavy metal feedrate limits were established using the results of comprehensive performance tests Veolia performed in August and September 2008. U.S. EPA is proposing to incorporate into Veolia's Title V permit the mercury feedrate limits used by the company during its 2008 testing. For the other heavy metals, the federal Agency is proposing slightly higher feedrate limits than the ones used in the 2008 tests. These higher feedrates are allowed under federal regulations.

Monitoring

In the proposed revisions to the Title V permit, Veolia will be required to install and operate a multi-metals continuous emissions monitoring system (CEMS) on one of its combustion units (Unit #3) for at least one

year. A multi-metals CEMS tests the air emitted during the incineration process to determine the amount of mercury, semi-volatile metals and low-volatile metals emissions, and reports the results approximately once every fifteen minutes. The test results will help U.S. EPA ensure the feedrate limits are adequate to protect air quality. After a year of running the CEMS, U.S. EPA believes we will have enough information to determine if the feedrate limits we are currently proposing are adequate to ensure that Veolia complies with the requirements of the Clean Air Act. Once U.S. EPA has collected sufficient data, Veolia will no longer be required to use the multi-metals CEMS.

Public participation

You can participate in the decision-making process on the permit by submitting comments during the public comment period that runs from Jan. 8 to April 1, 2013 or at the Feb. 19 public hearing in East St. Louis (*see front page box*).

All written comments must be postmarked or emailed **no later than April 1, 2013**. U.S. EPA will consider all written and oral comments received within the public comment period will be considered before making a final decision on the proposed action. U.S. EPA will consider written statements and supporting information submitted during the comment period with the same weight as any oral comments and supporting information presented at the public hearing. Your comments should include your name and address and all reasonable references, factual grounds, and supporting material. Be sure to note whether you would like to receive notification of U.S. EPA's final decision regarding the permit and its responses to comments submitted during the public comment period.

Comments can be submitted:

- Via the Internet at the www.regulations.gov/ website at Docket ID No. U.S. EPA-R05-OAR-2012-0649 or at www.epa.gov/region5/newsevents/ and look in the "public comment" section.
- Mail to **George Czerniak**, U.S. EPA, 77 W. Jackson Blvd. (A-18J), Chicago, IL 60604.
- Email to **John Mooney** at mooney.john@epa.gov.

At the Feb. 19 public hearing you will be invited to present any comments or concerns you have about the proposed changes. U.S. EPA is required to consider all comments and respond to all relevant comments. A signup sheet will be available at the public hearing for those who are interested in presenting oral testimony and spots will be available to present on a first-come/first-serve basis.

Each speaker will be limited to 5 to 10 minutes depending on the number of presenters. The U.S. EPA representative may ask clarifying questions during the oral presentations but will not respond to the comments at that time. If you require translation services or special accommodations for the public hearing contact U.S. EPA's Andrea Morgan at morgan.andrea@epa.gov by February 5, 2013.

View the documents

The draft permit and another document called a *statement of basis*, which explains the bases for the proposed revisions to the permit, can be reviewed at:

- The www.regulations.gov/ website at Docket ID No. U.S. EPA-R05-OAR-2012-0649 or at www.epa.gov/region5/newsevents/ and look in the "public comment" section.
- **Central Library**, 1301 Olive St, St. Louis, MO 63103.
- **East St Louis Library**, 5300 State St., East St Louis, IL 62203.
- **Cahokia Public Library**, 140 Cahokia Park Drive, East St Louis, IL 62206