

*Development Document for Effluent Limitations Guidelines  
and New Source Performance Standards for the*

# **CEMENT MANUFACTURING**

*Point Source Category*

JANUARY 1974



U.S. ENVIRONMENTAL PROTECTION AGENCY

Washington, D.C. 20460

DEVELOPMENT DOCUMENT  
for  
EFFLUENT LIMITATIONS GUIDELINES  
and  
NEW SOURCE PERFORMANCE STANDARDS  
for the  
CEMENT MANUFACTURING CATEGORY

Russell E. Train  
Administrator

Roger Strelow  
Acting Assistant Administrator for Air & Water Programs



Allen Cywin  
Director, Effluent Guidelines Division

John E. Riley  
Project Officer

January 1974

Effluent Guidelines Division  
Office of Air and Water Programs  
U. S. Environmental Protection Agency  
Washington, D. C. 20460



## ABSTRACT

This report presents the findings of a study of the cement manufacturing industry by Southern Research Institute for the Environmental Protection Agency for the purpose of developing effluent limitation guidelines -- setting forth the degree of effluent reduction attainable through the application of the best practicable control technology currently available and the degree of effluent reduction attainable through the application of the best available technology economically achievable which must be achieved by existing plants by July 1, 1977 and July 1, 1983 respectively; and standards of performance; and pretreatment standards for the industry -- setting forth the degree of effluent reduction achievable through the application of the best available demonstrated control technology, processes, operating methods, or other alternatives -- to implement Sections 304, 306, and 307 of the Federal Water Pollution Control Act, as amended.

Nonleaching plants can achieve essentially no discharge of pollutants by July 1, 1977 through the implementation of technology consisting of recycling and reuse, or isolation of cooling water from possible contamination and containment or treatment of runoff from materials storage piles. This technology also applies to 1983 limitations and standards for new sources, and to the nonleaching streams at leaching plants. For leaching streams, the recommended limitations for 1977 are a pH of 6.0 to 9.0 and suspended solids of not more than 0.04 kg/kg (0.8 lb/t) of dust leached achievable by neutralization and sedimentation. Elimination of dissolved solids by 1983 will require the transfer of treatment technology (electrodialysis) from other industries.

Supporting data and rationale for the development of the proposed guidelines and standards are contained in this report.

CONTENTS		<u>Page</u>
<u>Section</u>		
I	Conclusions	1
II	Recommendations	3
	Best Practicable Control Technology Currently Available	3
	Best Available Technology Economically Achievable	3
	New Source Performance Standards	3
III	Introduction	5
	Purpose and Authority	5
	Basis for Guidelines Development	5
	Description of the Cement Manufacturing Industry	11
	Description of the Manufacturing Process	14
	Kiln-Dust Considerations	19
IV	Industry Categorization	23
	Introduction	23
	Factors Considered	23
V	Water Use and Waste Characterization	31
	General	31
	Specific Water Uses and Waste Characteristics	31
VI	Selection of Pollutant Parameters	39
	Definition of Pollutants	39
	Parameters Selected as Pollutants	39
	Rationale for Selection of Specific Parameters as Pollutants	39
	Rationale for Rejection of Specific Parameters as Pollutants	48

CONTENTS

<u>Section</u>		<u>Page</u>
VII	Control and Treatment Technology	51
	Introduction	51
	In-Plant Control Measures	52
	Treatment Technology	54
	Description of Plants That Demonstrate Control and Treatment Technology	61
VIII	Cost, Energy, and Nonwater Quality Aspects	75
	Cost and Reduction Benefits of Alternative Control and Treatment Technologies	75
	Effects of Costs on the Industry	79
	Energy Requirements	80
	Nonwater Quality Aspects	80
IX	Effluent Reduction Attainable Through Application of the Best Practicable Control Technology Currently Available; Effluent Limitations Guidelines	93
	Introduction	93
	Identification of BPCTCA	93
	Rationale for Selection of BPCTCA	95
X	Effluent Reduction Attainable Through The Application of the Best Available Technology Economically Achievable; Effluent Limitations Guidelines	99
	Introduction	99
	Identification of BATEA	100
	Rationale for Selection of BATEA	100
XI	New Source Performance Standards and Pretreatment Standards	103
	New Source Performance Standard	103
	Pretreatment Standards	103

<u>Section</u>	CONTENTS	<u>Page</u>
XII	Acknowledgments	105
XIII	References	107
XIV	Glossary	111
	Definitions and Terminology	111
	Conversion Factors	115

## FIGURES

		<u>Page</u>
1	Waste Water Survey Questionnaire	7-8
2	Sample Data Sheet	10
3	Geographical Distribution of Operating Cement Plants	15
4	Flow Sheet for the Manufacture of Portland Cement	17
5	Kiln Dust Collection and Handling	21
6	Comparison of Loading of Selected Parameters for Leaching and Non- leaching Plants	25
7	Diagram of Water Usage in Cement Manufacturing	34
8	Distribution of Reported Maximum pH	42
9	Distribution of Calculated Average Temperature Rise	47
10	Solubility of Calcium Carbonate as a Function of pH	55
11	Diagram of Electrodialytic Treatment of Leachate	58
12	Flow Sheet for the Recovery of Potassium Sulfate from Kiln Dust	62
13	Diagram of Water-Management Plan for Plant A	64
14	Diagram of Water-Management Plan for Plant B	66
15	Diagram of Water-Management Plan for Plant C	67



FIGURES (continued)

Page

16	Diagram of Water-Management Plan for Plant D	69
17	Diagram of Water-Management Plan for Plant G	71
18	Diagram of Water-Management Plan for Plant H	72

## TABLES

		<u>Page</u>
1	Summary of Features of Plants Studied	9
2	Distribution of Plants by Reported Loading for 18 Parameters	12
3	Comparison of Reported and Measured Waste Loads at Plants Visited	13
4	Distribution of Portland Cement Plants by Capacity	16
5	Summary of Methods of Dust Utilization and Disposal	22
6	Comparison of Loadings of Selected Parameters for Wet- and Dry-Process Plants	26
7	Comparison of Loadings and Water Discharged for Plants of Different Capacity	28
8	Comparison of Loadings for Leaching and Nonleaching Subcategories	32
9	Summary of Water Usage for the Cement Manufacturing Industry	33
10	Reported Cooling Water Usage in Cement Plants	35
11	Loadings of Pollutant Parameters for Leaching and Nonleaching Plants	40
12	Water Effluent Treatment Cost and Pollution Reduction Benefits	76-78
13	Plant Production Costs	81
14	Comparison of Typical Plant with Actual Plants in the Industry	82
15	Indexes of Comparative Equipment Cost	83
16	Table of Conversion Factors	115



## SECTION 1

### CONCLUSIONS

For the purpose of establishing effluent limitations guidelines and standards of performance for new sources, the cement manufacturing industry is divided into three subcategories: leaching plants (those that use water in contact with kiln dust as an integral part of the process as in the leaching of dust for reuse or wet scrubbing to control stack emissions), nonleaching plants and materials storage piles runoff.

Process waste water pollutants are those constituents of discharged water that are added in quantities (greater than 0.005 kg/kg (0.01 lb/t) of product) as a result of the water being used in manufacturing operations characteristic of the industry.

Presently about 35 of 154 nonleaching plants are achieving essentially no discharge of pollutants; that is, they are discharging less than 0.005 kg/kg of (0.01 lb/t) of product not including runoff. The remaining 119 plants can also achieve essentially no discharge of pollutants by July 1, 1977.

For the approximately 9 plants in the leaching subcategory, substantial reduction in suspended solids and pH can be achieved by July 1, 1977 with existing technology. However, elimination of dissolved solids by July 1, 1983 will require the adaptation of additional treatment technology by the industry.

As a result of comments from industry and the Agency's consideration of the need to control runoff from kiln dust, clinker and coal storage piles, a third subcategory, materials storage piles runoff, has been established. Because of the impracticability of basing the limitations on some unit of production, it was concluded that concentration should be used to express the effluent limitations for this subcategory. As an alternative to no discharge of pollutants by existing sources, limitations of 50 mg/l have been set for suspended solids and pH is to be controlled within the range 6.0 to 9.0. For new sources, it was concluded that material storage piles can be sited on the plant property so as to not discharge runoff to navigable waters.

It is estimated that the costs of achieving the limitations and standards for 1977 by all plants in the industry is less than \$50,000,000. As a result of implementing the 1977 limitations and standards, the increased cost of producing cement is estimated to range from 1.0 to 1.5 percent.

The cost of the additional treatment technology required for plants currently leaching to meet 1983 limitations and standards is less than \$4,000,000. As a result of implementing the 1983 limitations and standards, the increased cost of producing cement is estimated to range from 0.6 to 0.9 percent above the costs required to meet 1977 limitations and standards.



## SECTION II

### RECOMMENDATIONS

#### Best Practicable Control Technology Currently Available

For plants in the nonleaching subcategory, essentially no discharge of pollutants in manufacturing effluents is recommended as the limitation except for temperature where an increase of 3°C is recommended as the limitation. This represents the degree of effluent reduction attainable by existing plants by July 1, 1977 through the application of the best practicable control technology currently available.

The technology on which this limitation is based consists of isolation of cooling water from possible contamination, and recycling or reuse of other water (including cooling water if not isolated).

For plants in the leaching subcategory, the degree of improvement in effluent quality that is achievable through application of the best practicable control technology currently available is the same as those for plants in the nonleaching subcategory for all except the dust-contact streams where reduction of pH to 9.0 and suspended solids to 0.4 kg/kkg (0.8 lb/ton) of dust leached is recommended as the effluent limitation.

The technology on which the limitation for leaching streams is based consists of segregation of dust-contact streams and neutralization with stack gases followed by sedimentation.

For plants subject to the provisions of the Materials Storage Piles Runoff Subcategory either the runoff should be contained to prevent discharge or the runoff should be treated to neutralize and reduce suspended solids prior to discharge to navigable waters.

#### Best Available Technology Economically Achievable

Essentially no discharge of pollutants is recommended as the effluent limitation for nonleaching plants and leaching plants to be achieved by July 1, 1983.

For plants subject to the provisions of the Materials Storage Piles Runoff Subcategory the technology described for best practicable control technology currently available should be permitted to extend into 1983 as best available technology economically achievable.

#### New Source Performance Standards

For leaching plants, the limitation is based on the use of processes shown to be feasible in other industries for reducing the dissolved solids in the leachate stream, and recycling the stream. One such process is electrodialysis, which has been used for more than a decade in Japan for concentrating seawater to produce brines. In accordance with definition of Best Available Technology Economically Achievable,

the necessary technology is available, but some development by industry may be required prior to its application in the industry.

The effluent reduction attainable through the application of the best available demonstrated control technology is essentially no discharge of pollutants for nonleaching plants and for the nondust contact streams at leaching plants. For the dust contact streams at leaching plants reduction of suspended solids to less than 0.4 kg/kkg (0.8 lb/ton) of dust leached is attainable. These are the standards recommended for new plants and are based on the application of the technology described as Best Practicable, Currently Available. As the technology described as Best Available, Economically Achievable is developed and demonstrated, the performance standards for new leaching plants should be revised to reflect the recommendation of essentially no discharge of pollutants.

For plants in the Materials Storage Piles Runoff Subcategory it is recommended that the materials storage piles areas at cement plants be situated or facilities provided so that there is no discharge of runoff from materials storage piles to navigable waters.

## SECTION III

### INTRODUCTION

#### Purpose and Authority

Section 301(b) of the Act requires the achievement by not later than July 1, 1977, of effluent limitations for point sources, other than publicly owned treatment works, which are based on the application of the best practicable control technology currently available as defined by the Administrator pursuant to Section 304(b) of the Act. Section 301(b) also requires the achievement by not later than July 1, 1983, of effluent limitations for point sources, other than publicly owned treatment works, which are based on the application of the best available technology economically achievable which will result in reasonable further progress toward the national goal of eliminating the discharge of all pollutants, as determined in accordance with regulations issued by the Administrator pursuant to Section 304(b) of the Act. Section 306 of the Act requires the achievement by new sources of a Federal standard of performance providing for the control of the discharge of pollutants which reflects the greatest degree of effluent reduction which the Administrator determines to be achievable through the application of the best available demonstrated control technology, processes, operating methods, or other alternatives, including, where practicable, a standard permitting no discharge of pollutants.

Section 304(b) of the Act requires the Administrator to publish within one year of enactment of the Act, regulations providing guidelines for effluent limitations setting forth the degree of effluent reduction attainable through the application of the best practicable control technology currently available and the degree of effluent reduction attainable through the application of the best control measures and practices achievable including treatment techniques, process and procedure innovations, operation methods and other alternatives. The regulations herein set forth effluent limitation guidelines pursuant to Section 304(b) of the Act for the cement manufacturing source category.

Section 306 of the Act requires the Administrator, within one year after a category of sources is included in a list published pursuant to Section 306(b) (1) (A) of the Act, to propose regulations establishing Federal standards of performances for new sources within such categories. The Administrator published in the Federal Register of January 16, 1973 (38 F.R. 1624), a list of 27 source categories. Publication of the list constituted announcement of the Administrator's intention of establishing, under Section 306, standards of performance applicable to new sources in the cement manufacturing source category, which was included within the list published January 16, 1973.

#### Basis for Guidelines Development

The effluent limitations guidelines and performance standards recommended in this report were developed from an analysis of U.S. Army Corps of Engineers discharge permit applications and used questionnaires



to identify potential subcategories and exemplary plants and to obtain information on water use and waste water characteristics. Further on-site studies of potential exemplary plants were conducted to verify this information and observe the control and treatment technologies employed. Also, discussions were held with consultants and others knowledgeable of the manufacturing and waste treatment practices in the industry.

General information was obtained on 166 domestic cement plants identified as currently in operation, and detailed information was collected for 132 (80%) plants. The sources and type of information consisted of:

- Applications to the U.S. Army Corps of Engineers for permits to discharge under the Refuse Act Permit Program (RAPP). Permits were obtained for 88 plants that provided data on the characteristics of intake and effluent waters, water usage (including flow diagrams in many cases) waste water treatment and control practices employed, daily production, and raw materials used.
- A questionnaire sent to eight companies covering 64 plants (including plants for which RAPP application were not available). The questionnaire provided data on raw material analysis, dust collection and disposal methods, alkali content of the dust, plant age and year of latest modification, detailed water usage, fuels, and treatment and control methods and costs. A copy of the questionnaire is shown in Figure 1.
- On-site inspections of 15 selected plants which provided flow diagrams, detailed information on water management practices, and control and treatment methods, equipment, and costs. Table 1 summarizes the features of these plants.
- Other sources of information including EPA technical reports, trade literature, personal and telephone interviews and meetings with regional EPA personnel, industry personnel, and consultants which provided additional detailed information on the industry.

This information was compiled by data processing techniques and used to prepare data sheets for 123 plants, such as that illustrated for a hypothetical plant in Figure 2, and analyzed for the following:

- Identification of distinguishing features that could potentially provide a basis for subcategorization of the industry. These features included method of dust collection and disposal, type of process, raw materials, materials storage, plant size and age, and others, discussed in detail in Section IV.
- Determination of the water usage and waste character-

1. Initial construction date .....
2. Year of most recent expansion or major modification affecting water usage or wastewater quality .....
3. Typical daily production of cement, tons/day .....
4. Raw materials used (specify type). If a typical raw material assay is available, please attach a copy

Lime	_____	Alumina	_____
Silica	_____	Iron	_____

5. Type of Fuels used (give approximate proportions)

	Gas	Coal	Oil
Primary	_____	_____	_____
Alternate	_____	_____	_____

6. Is quarry a part of or immediately adjacent to plant site?  Yes  No  
If yes, could an area of the quarry be reserved for the following purposes?

	Possible usage	Present usage	Unknown
Dust disposal	<input type="checkbox"/>	<input type="checkbox"/>	<input type="checkbox"/>
Wastewater disposal	<input type="checkbox"/>	<input type="checkbox"/>	<input type="checkbox"/>
Water reservoir for re-cycling or reuse	<input type="checkbox"/>	<input type="checkbox"/>	<input type="checkbox"/>

7. Does plant have treatment facilities for wastewaters other than sanitary?  Yes  No

If yes: Date installed \_\_\_\_\_ Approximate capital cost \_\_\_\_\_  
Approximate operating cost \_\_\_\_\_ (\$/yr)

Describe \_\_\_\_\_  
\_\_\_\_\_  
\_\_\_\_\_

8. Has a Corps of Engineers' permit to discharge into navigable waters been applied for at this plant?

Yes  No

If no, has an analysis of the wastewater effluents from this plant ever been made?

Yes (please attach)  No

9. Does plant use kiln-dust leaching system?

Yes  No

Figure 1. Wastewater Survey Questionnaire

10. Water usage information:

In the table below indicate the source and daily amount (surface water, municipal, etc.) of intake water and the fate and daily amount (surface containment, surface streams, evaporation, etc.) of discharged water for each use. For recycled water, indicate makeup amount only under "Source" and estimate total amount of water that would be consumed without recycling in Question No. 11. For water that is reused for another purpose, indicate previous usage under "Source" and subsequent use under "Fate". For example, if cooling water is reused as slurry water, "Fate" for "cooling" is "slurry" and "Source" for "slurry" is "cooling".

Use	Intake		Discharge		Check if treated before discharge
	Source	Amount, gpd	Fate	Amount, gpd	
Boiler feed					<input type="checkbox"/>
Bearing cooling water					<input type="checkbox"/>
Cement-cooler water					<input type="checkbox"/>
Sanitary					<input type="checkbox"/>
Process (Slurry)					<input type="checkbox"/>
Dust leaching					<input type="checkbox"/>
Dust control					<input type="checkbox"/>
Quarry dewatering					<input type="checkbox"/>
Contact clinker cooling					<input type="checkbox"/>
Raw material washing and beneficiation					<input type="checkbox"/>
Other _____ (specify)					<input type="checkbox"/>
	<u>Total intake</u>		<u>Total discharge</u>		

11. Describe quantity and use of any water that is recycled \_\_\_\_\_  
 \_\_\_\_\_  
 \_\_\_\_\_

12. Types of kiln-dust collection system(s) used:

- Cyclones                       Wet scrubbers  
 Bag houses                       None  
 Precipitators                       Other (specify) \_\_\_\_\_

13. Estimated or designed kiln-dust collection efficiency: \_\_\_\_\_%

14. Disposition of collected kiln-dust:

- (a) Returned to kiln: \_\_\_\_\_ tons/day; alkali content \_\_\_\_\_%  
 (b) Not returned to kiln: \_\_\_\_\_ tons/day; alkali content \_\_\_\_\_%

15. Method of disposal:  Surface piling     Return to quarry

- Utilized in some way (specify) \_\_\_\_\_  
 Other (specify) \_\_\_\_\_

Figure 1 (continued). Wastewater Survey Questionnaire

TABLE 1

## Summary of Features of Plants Studied

<u>Features</u>	<u>Number of Plants</u>
<u>Type of Process</u>	
Wet	10
Dry	5
<u>Method of Dust Collection and Disposition</u>	
All returned to kiln	3
Leach	3
Surface pile or quarry	8
Wet slurry	1
Wet scrubber	1
<u>Plant Age</u>	
Built before 1920	4
1920 to 1939	3
1940 to 1959	4
1959 to present	4
<u>Plant Capacity, Thousand metric tons/year</u>	
450 or less	4
450 to 900	9
Over 900	1
<u>Raw Materials</u>	
Limestone	10
Marl	2
Oyster Shell	3
<u>Type of Primary Fuel</u>	
Gas	10
Coal	3
Oil	2
<u>Plant Location</u>	
Northeast	3
South	4
Midwest	4
West	4

MAY 23, 1973-2

COMPANY AND PLANT, NAME AND LOCATION				RAPP CODE	EPA REGION	SRI CODE
BEDROCK CEMENT CO CLINKERVILLE USA				0900X52710444	5	5805
PLANT CAPACITY KTONS/YR	NUMBER OF EMPLOYEES	NUMBER OF KILNS	DAILY PRODUCTION TONS/DAY	TYPE OF PROCESS	RAW MATERIALS	PRIMARY KILN FUEL
750.	90	3	2100.	WET	LIMESTONE CLAY IRON ORE	COAL

PLANT BUILT IN 1967  
DUST CONTACT WATER DISCHARGED  
PERMITS OTHER THAN RAPP ARE REPORTED  
PLANT HAS WASTEWATER TREATMENT FACILITY  
RECYCLING OR REUSE OF WATER IS INDICATED

WATER INTAKE, MGPD		WATER USAGE, MGPD		DISCHARGE BY FATE, MGPD		NON-DISCHARGE FATES, MGPD	
PUBLIC SOURCE	0.100	COOLING	2.160	MUN WASTE SYSTEM	0.100	EVAPORATION	0.100
SURFACE WATER	2.160	BOILER FD	0.000	SURFACE CNTNMNT	0.000	CONSUMPTION	0.520
GROUND WATER	0.000	PROCESS	0.520	UNDERGROUND DISP	0.000		
OTHER SOURCES	0.000	SANITARY	0.100	ACCEPTANCE FIRMS	0.000		
		OTHER USE	0.000	NAVIGABLE STREAM	1.928		
<b>TOTAL INTAKE</b>	<b>2.260</b>	<b>TOTAL USE</b>	<b>2.780</b>	<b>TOTAL DISCHARGE</b>	<b>2.028</b>	<b>TOTAL OTHER FATES</b>	<b>0.620</b>
INTAKE,GAL/TON	1076.			DISCHARGE,GAL/TON	965.	UNACCOUNTED FOR,MGPD	0.387

## INDIVIDUAL DISCHARGE STREAM DATA

STREAM NO	1	2	3	4	5	6	7	8	9	10	11	12	13	14	15
FLOW, MGPD	1.580	0.060	0.288	0.000	0.000	0.000	0.000	0.000	0.000	0.000	0.000	0.000	0.000	0.000	0.000
USES	031	005	007	000	000	000	000	000	000	000	000	000	000	000	000
TREATMENTS	01	82	02	00	00	00	00	00	00	00	00	00	00	00	00

NAVIGABLE STREAM DATA, MGPD		THERMAL INPUT TO NAVIGABLE STREAMS, KBTU PER DAY				AVERAGE TEMPERATURE RISE FOR ALL STREAMS, DEG F			
		WINTER		SUMMER		WINTER		SUMMER	
TOTAL FOR INTAKE STREAMS		1.928							
TOTAL FOR DISCHARGE STREAMS		1.928							
STREAM IMBALANCE		0.000	26400.	209200.	12.57	99.61	1.6	13.0	

## NET LOADING OF POLLUTANTS IN LB/DAY AND LB/TON OF PRODUCT (\*-INDICATES .001 LB)

MAX PH		ALKALINITY		BOD	COD	TOT SOLIDS	DIS SOLIDS	SUS SOLIDS	VOL SOLIDS	AMMONIA
8.9	PER DAY	233.51		0.00	-1.16	5719.06	5719.06	27.35	58.04	0.10
2.	PER TON	0.111		0.000	-0.000	2.723	2.723	0.013	0.027	0.000
K NITROGEN		N AS NO3	PHOSPHRS	OIL & GRS	CHLORIDE	SULFATE	SULFIDE	*PHENOLS	*CHROMIUM	
PER DAY	41.17	0.00	0.00	1.85	0.00	1279.02	*****	0.00	0.00	
PER TON	0.019	0.000	0.000	0.000	0.000	0.609	*****	0.000	0.000	

Figure 2. Sample Data Sheet

istics for each subcategory, discussed in Section V, including the volume of water used, the sources of contamination in the plant, and the type and quantity of constituents in the waste waters.

- Identification of those constituents, discussed in Section VI, which are characteristic of the industry and present in significant quantities to be judged pollutants subject to effluent limitations guidelines and standards.

The results of this analysis, shown in Table 2, indicated that at least 20% of the plants in the industry are currently achieving essentially no discharge of pollutants, that is, they are discharging less than 0.005 kg/kg (0.01 lb/ton) of product which corresponds to about 1 mg/l, the minimum, readily, measurable concentration at the flow rates common in this industry. The reliability of the reported RAPP data was verified by sampling and analysis at ten plants. The average of the measured and reported loadings of seven nonleaching plants and three leaching plants are shown in Table 3. With the exception of dissolved solids at leaching plants, the deviation of either measurement from the mean of the two is well within the reliability of methods. In subsequent sections of this report, the data base used in the development of charts, tables, and figures includes all 166 plants except as otherwise indicated.

The control and treatment technologies employed at plants with essentially no discharge of pollutants as well as those at leaching plants identified during the on-site studies and are discussed in Section VIII.

The information, as outlined above, was then evaluated in order to determine which levels of technology constituted the "best practicable control technology currently available," and the "best available demonstrated control technology, process, operating methods, or other alternatives." In identifying such technologies, various factors were considered. These included the feasibility of using technology employed by other industries, the total cost of application of technology in relation to the effluent reduction benefits to be achieved from such application, the process employed, the engineering aspects of the application of various types of control techniques, nonwater quality environmental impact (including energy requirements) and other factors as discussed in Sections IX, X, and XI.

#### Description of the Cement Manufacturing Industry

The cement manufacturing industry is classified by the Department of Commerce as SIC group 3241 (Hydraulic Cement). The products produced by the industry are various types of portland cement, manufactured to meet different requirements.

There were 51 companies with 166 plants identified as being in operation in the United States and Puerto Rico during 1972. These plants are

TABLE 2

## DISTRIBUTION OF PLANTS BY REPORTED LOADING FOR 18 PARAMETERS

Number of Plants Reporting	Waste Load, kg/kg					
	Less than .005	.005 to .049	.05 to .49	0.5 to 4.9	Greater than 5	
Alkalinity	78	44	8	15	11	0
BOD	74	59	14	1	0	0
COD	69	40	17	12	0	0
Total solids	79	28	15	11	13	12
Dissolved solids	77	27	11	19	8	12
Suspended solids	75	35	13	18	8	1
Volatile solids	73	34	13	15	11	0
Ammonia	69	69	0	0	0	0
Kjeldahl nitrogen	67	65	1	1	0	0
Nitrate as N	69	66	3	0	0	0
Phosphorus	71	71	0	0	0	0
Oil and grease	56	51	3	2	0	0
Chloride	67	48	6	9	4	0
Sulfate	68	36	11	10	10	1
Sulfide	50	50	0	0	0	0
Phenols*	56	52	1	3	0	0
Chromium*	62	55	2	4	1	0
Potassium	15	7	1	3	3	1

---

\*Load expressed in g/kg.

TABLE 3

## COMPARISONS OF REPORTED AND MEASURED WASTE LOADS AT PLANTS VISITED

Parameter	<u>Nonleaching Plants (7)</u> Average Waste Loads, kg/kg (lb/ton) of Product				<u>Leaching Plants (3)</u> Average Waste Loads, kg/kg (lb/ton) of Product			
	Reported by Plants	Measured by SRI staff	Mean of Reported and Measured Average	Deviation from Mean kg/kg of Product	Reported by Plants	Measured by SRI staff	Mean of Reported and Measured Average	Deviation from Mean kg/kg of Product
Alkalinity	0.001 (0.002)	0.001 (0.002)	0.001 (0.002)	+0.000	1.09 (2.18)	1.21 (2.42)	1.15 (2.30)	+0.006
Dissolved Solids	0.029 (0.058)	0.032 (0.064)	0.030 (0.061)	+0.002	5.65 (11.30)	2.98 (5.96)	4.32 (8.63)	+1.34
Suspended Solids	0.009 (0.018)	0.022 (0.044)	0.015 (0.031)	+ 0.006	0.045 (0.09)	0.045 (0.09)	0.045 (0.09)	+0.000
Sulfate	0.001 (0.002)	0.006 (0.012)	0.003 (0.007)	+0.002	- -	1.06 (2.12)	- -	-
Potassium	- -	0.001	- -	-	- -	0.885 (1.77)	- -	-

Data derived from visits to and RAPP applications for 10 plants.



widely distributed, as shown on the map in Figure 3, being located in all but nine states, in areas close to sources of raw materials, transportation routes, and local markets.

The number of plants in operation has declined from a high of 188 (12) in 1967 to the estimated 166 plants at the end of 1972. In addition to these, about five plants are presently shut down for modernization, and five new plants are under construction. Expansion programs are also underway or planned at about 20 existing plants.

The annual capacity of these plants ranges from 0.18 to 2.7 million metric tons (0.2-3.0 million short tons). Table 4 shows the number of plants in each of four size categories.

In 1971 the production of clinker by domestic plants was about 68 million kkg (75 million tons). (7) According to the U. S. Department of Commerce (6), the value of cement shipments will grow from \$1.6 billion in 1971 to \$2.2 billion by 1975 and \$3.1 billion by 1980.

Excess capacity has existed in the industry since a major expansion in the early sixties. In 1971, the capacity utilization was about 88%, and is estimated at 90% for 1972 -- the highest in over 10 years. Expansion programs currently underway should increase capacity about 2% in 1973. (6)

#### Description of the Manufacturing Process

Cement is manufactured by a continuous process, normally interrupted only to reline the kilns. There are 3 major steps in the production process: grinding and blending of raw materials; clinker production; and finish grinding. These steps are illustrated in Figure 4.

The ordinary ingredients for the production of cement include lime (calcium oxide), silica, alumina, and iron. Lime which constitutes the largest single ingredient, is most commonly obtained from limestone, cement rock, oyster shell marl, or chalk, all of which are principally calcium carbonate. Materials such as sand, clay, shale, iron ore and blast furnace slag are added to obtain the proper proportions of the other ingredients. At some plants it is necessary to beneficiate the raw materials before they can be used. For example, if the most economical supply of clay contains too much sand, the mixture can be separated by washing with water.

Two types of processes are used in the manufacture of cement, "wet" and "dry." At wet plants, the raw materials are ground with water and fed to the kiln in a slurry. At dry plants the raw materials are dried before grinding, and are ground and fed to the kiln in a dry state. The moisture content of the raw materials available at a given location frequently determines which process a plant will use. For example, if clay and marl with a high water content are available, the wet process may prove more economical.

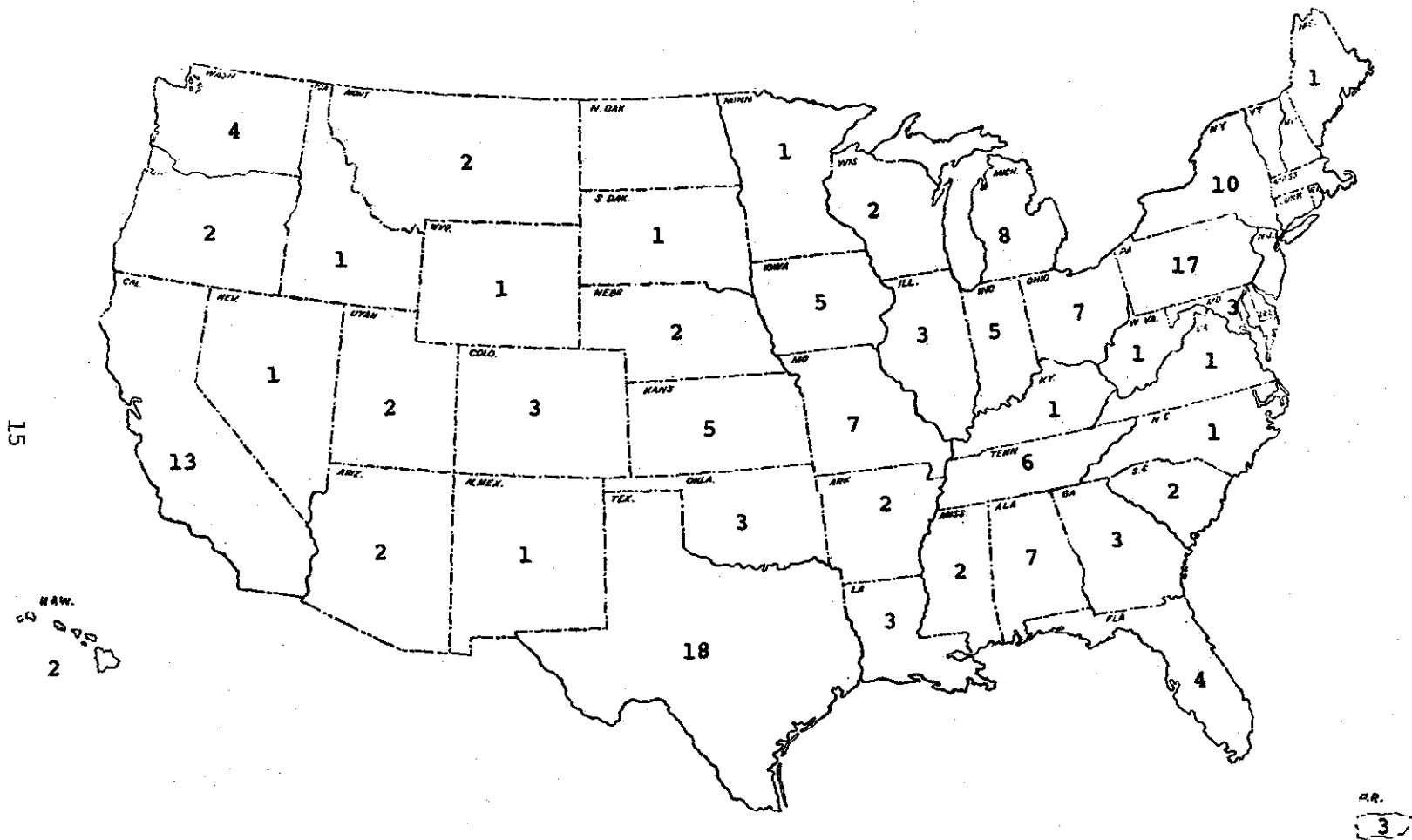

Figure 3. Geographical Distribution of Operating Cement Plants

DRAFT

TABLE 4

DISTRIBUTION OF PORTLAND CEMENT PLANTS BY CAPACITY

<u>Rated Annual Capacity</u>		<u>Number of Plants</u>	<u>Percent of Total Plants</u>	<u>Percent of Industry Capacity<sup>a</sup></u>
<u>(thousands of metric tons)</u>	<u>(thousands of short tons)</u>			
0-270	0-300	31	18.7	7.4
270-455	300-500	56	33.7	24.0
455-910	500-1000	66	39.7	47.6
over 910	over 1000	<u>13</u>	<u>7.9</u>	<u>21.0</u>
		166	100.0	100.0

---

a. Total rated annual capacity of industry is 86-million metric tons (95-million short tons).

Data derived from RAPP applications, questionnaires, and industry publications.

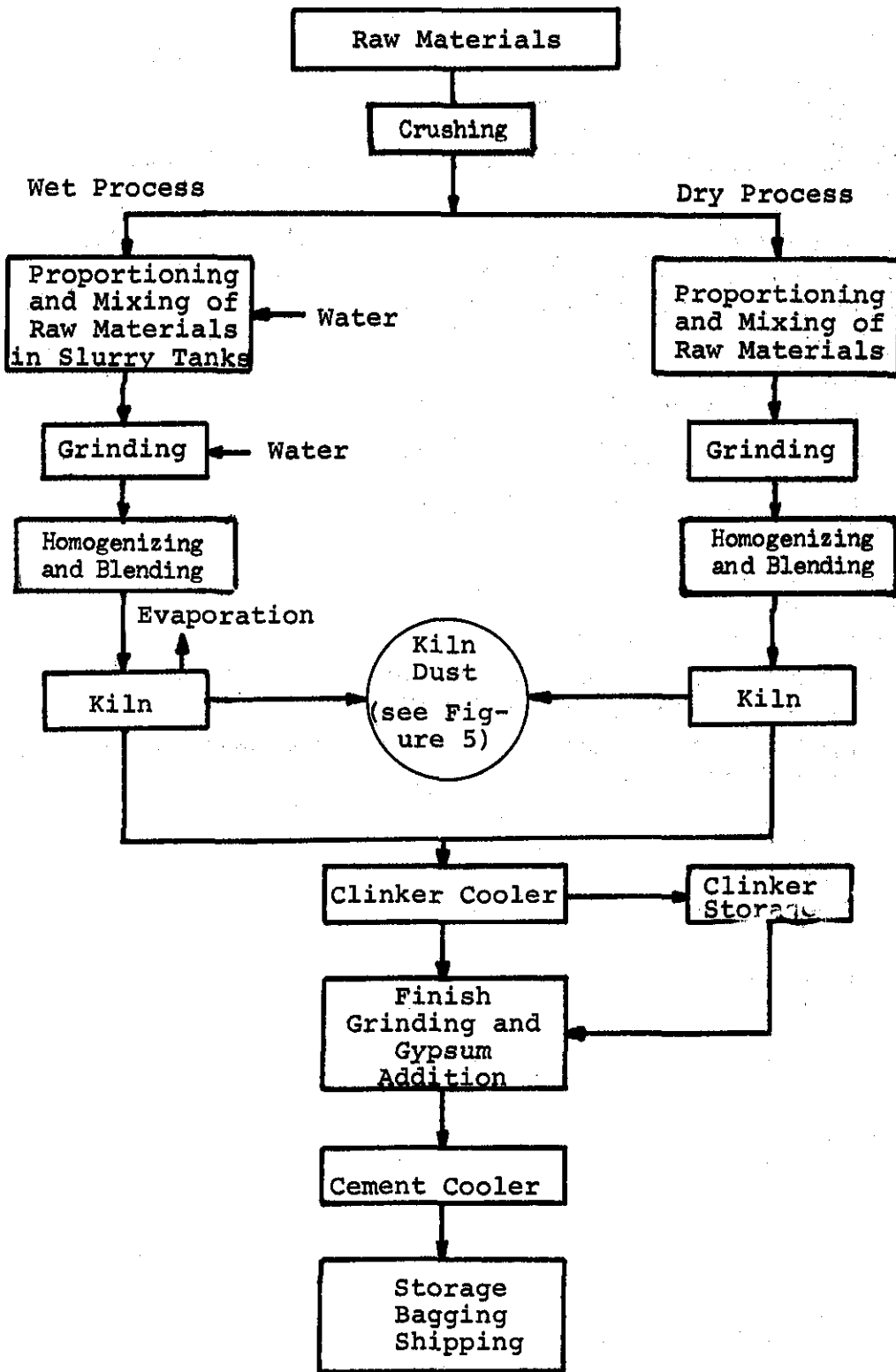

Figure 4. Flow Sheet for the Manufacture of Portland Cement

After the raw material has been finely ground it is placed in storage containers--silos for dry process and slurry tanks for wet process. The material is analyzed and the composition is adjusted as necessary to obtain the correct formulation for the type of cement being produced.

The ground raw materials are fed to a kiln consisting of a large rotating metal tube, usually 3.7 m (12 ft) or more in diameter and 75 to 150 m (250 to 500 ft) long, lined with refractory brick on the inside. The kiln is inclined slightly so that the contents are transferred forward as the kiln rotates. The raw materials are fed into the elevated end, and the kiln is heated by a flame at the lower end. An array of heavy steel chains near the entrance is used sometimes and serves to transfer heat from the gas stream to the raw materials.

The fuel for the kiln may be coal, gas or oil. Most cement plants are equipped to burn more than one type of fuel, and the fuel used at any particular time is dictated by availability and cost. When available, natural gas is usually the least expensive fuel, but in order to obtain gas at the most favorable price, the manufacturer must agree to curtail its use when supplies are limited, and must, therefore, use coal or oil as a standby fuel.

The amount of fuel used to manufacture cement varies with the efficiency of the kiln, the composition of raw materials, the process used, and many other operational factors. In 1963, on the average, the production of one metric ton of cement required about 246 kg (541 lb) of coal, or 187 cu m (6670 cu ft) of natural gas which is equivalent to approximately 1.5 million kg cal. (5.8 million BTU). (29) Newer plants would be expected to consume about 20% less fuel. Although the wet-process kiln has a higher heat requirement than the dry-process kiln, the fuel consumption difference, in many cases, is partially offset by the heat consumed in those dry-process plants in which dryers precede the raw materials grinding.

As the raw materials proceed down the kiln their temperature increases to about 1600°C (2900°F). At this temperature the raw materials reach a point of incipient fusion and hard, marble-sized balls, called clinker, are formed as the clinker comes from the kiln it is rapidly cooled by air (part of which is subsequently used as combustion air in the kiln).

The clinker along with a small amount of gypsum, added to regulate the setting time, is ground into a fine powder. The grinding energy is dissipated as heat in the product and the cement is cooled before being bagged or shipped in bulk to the user. One type of cement cooler consists of a large, vertical cylinder with a rotating screw that pushes the cement through the cooler. The heat is removed by water, which flows through an enclosed jacket around the cooler or cascades in the open, down the outside.

The finely ground cement is transported within the plant by pneumatic pumps. The air is supplied by water cooled compressors. After the air has been used to convey the cement it is cleaned by bag filters, and the dust removed is returned to the product stream. In dry-process plants

much dust is associated with the grinding and pneumatic pumping of raw material. This dust can also be collected in bag houses and returned to the process.

### Kiln-Dust Considerations

Because of its impact on the environment, the collection and disposition of kiln dust deserve special consideration.

The greatest source of dust at most cement plants is from the kiln. The rotation of the kiln plus the rapid flow of gases (from the evolution of carbon dioxide from the raw materials) and the motion of the chains cause a large amount of the finely ground material to become airborne. The high-velocity gases flowing through the kiln carry large quantities of this dust (typically 10 to 20% of the kiln feed) out of the feed end of the kiln. The large dust particles can be removed from the gases by mechanical collectors (cyclones), but the smaller particles require more expensive dust collectors (electrostatic precipitators, bag filters, or wet scrubbers). Reuse of collected dust, if compatible with the process, is advantageous from three points of view -- conservation of raw materials, reduction of disposal costs, and reduction in accumulation of solid wastes.

There are two ways to return collected dust to the kiln. In some plants the dust is mixed with the raw feed. In other plants the dust is blown in through a pipe in the hot end of the kiln, a technique known as insufflation. A portion of the dust is often wasted to prevent buildup of a large amount of fine particulate matter containing alkali salts that continuously cycles between dust collector and kiln.

The dust that is removed from the kiln gases by the dust collectors is a mixture of particles of raw material, clinker, and materials of intermediate composition. The gases also contain alkalies from raw materials and fuel that are volatilized in the hottest portion of the kiln and condensed into a fume as the gases passed through the kiln. The alkalies in the raw material are insoluble because they are tightly bound in a mineralogical matrix. The high temperature in the kiln alters the matrix sufficiently to free a large portion of the alkalies. The free alkali is volatile at high temperatures, and it is also water soluble.

American Society for Testing Materials and Federal specifications require that the alkali content of certain cement products not exceed 0.6%. The low-alkali specification is only necessary in cases of known or suspected alkali reactions with the aggregate being used, but many building and construction contractors routinely specify low alkali cement regardless of the characteristics of the aggregate. Therefore, since many manufacturers have difficulty marketing high-alkali cement, they strive to make a low alkali cement as a standard product. For plants that use raw materials with a high alkali content, the dust cannot be returned directly to the kiln, and its reuse and disposal constitute a serious problem in the industry.

As air pollution control regulations have become more stringent, the amount of high-alkali dust that is collected has increased, and as more manufacturers install dust collectors that remove more than 99% of the particulate load from the stack gases, the problem of disposal of high-alkali dust will increase. Measures to minimize water pollution stemming from increased amounts of high-alkali dust are described in Section VII.

Figure 5 shows a schematic of the kiln dust collection and handling systems currently employed in the industry.

Table 5 summarizes the methods employed to dispose of kiln dust as reported by 80 plants. As shown in the Table, only 27 (34%) of these plants are able to return all of the collected dust to the kiln.

Presently most manufacturers are wasting the collected kiln dust that cannot be returned to the kiln. The dust is hauled or slurried either to an unused part of the quarry or to vacant land near the plant. The presence of the dust limits the future use of the dumping site. Moreover, leaching of the dust piles by rainwater overflow from slurring can cause pollution of streams and ground water.

To avoid wasting high-alkali dust, some manufacturers have installed kiln dust leaching systems. The dry dust is mixed with water in a pug mill to make a slurry containing about 10% solids. The soluble alkalies, usually at least half of the alkali content, immediately dissolve. The slurry flows into a clarifier where the solid material falls to the bottom. The underflow from the clarifier which contains 40 to 60% solids is returned to the kiln. The overflow, which contains the alkalies is discharged. This discharge constitutes the most severe water pollution problem in the industry.

Another alternative is to use only raw materials of low alkali content. Many cement manufacturers do not have a dust disposal problem because their quarries contain low-alkali raw materials. However, the alkali content of the raw materials is only one of the many factors that must be considered in selecting a plant site, and many of the present cement plants were constructed long before alkali problems became significant. Cohrs (20) made a survey of 30 plants built since 1960 and found that only ten had anticipated dust disposal problems prior to construction and had made plans to handle it. In some cases plants have hauled in low-alkali raw materials to avoid a dust disposal problem, but most plants would find this solution economically prohibitive.

Since waste kiln dust has a high potassium content and considerable capacity for neutralizing acids, suitable uses for the material have been proposed. Some of the applications that have been considered are fertilization, soil stabilization, and neutralization of acidic wastes from metal pickling operations and mine drainage. Although such uses for waste dust have been pursued for many years, most of the dust now being collected is discarded.

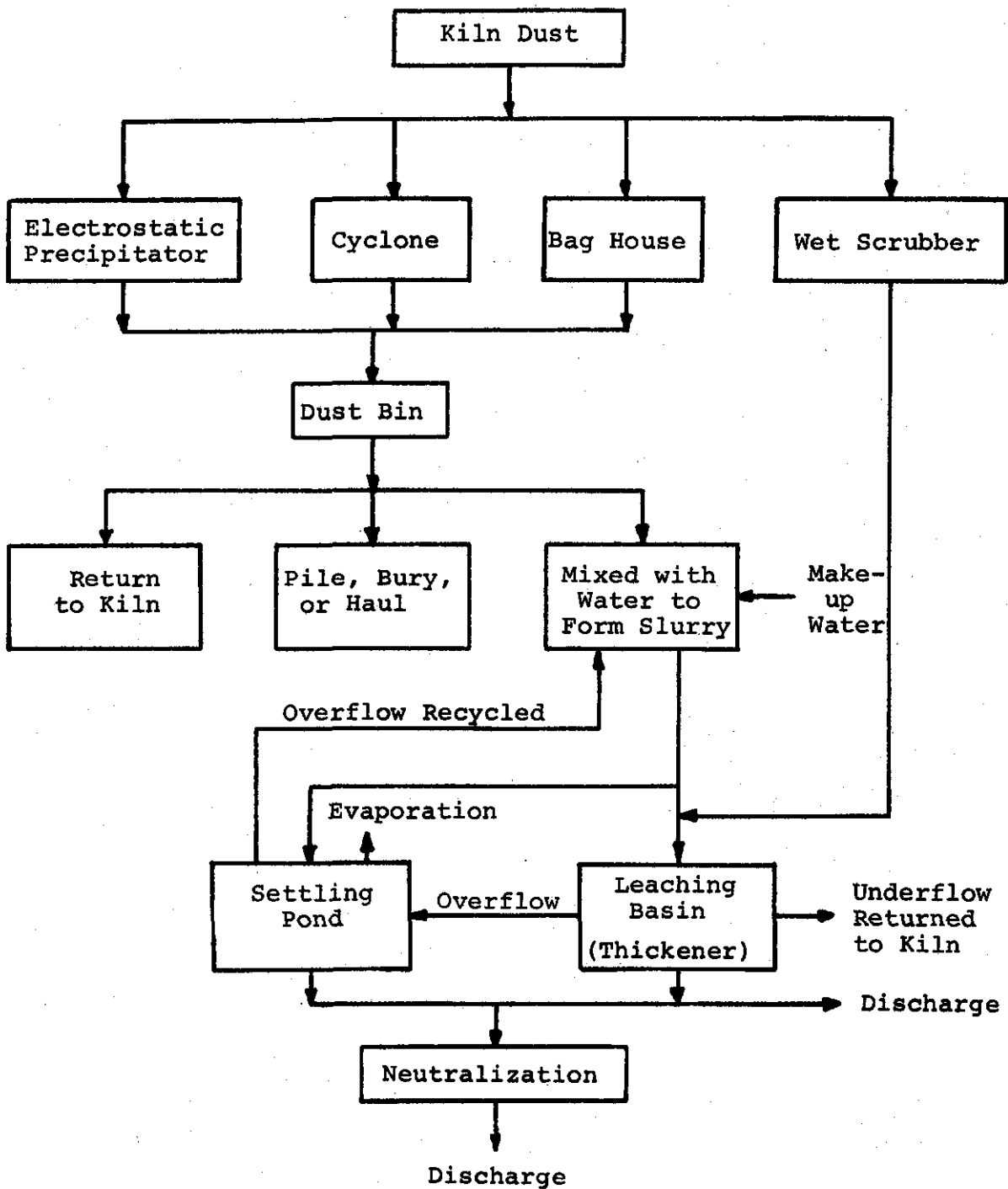

Figure 5. Kiln Dust Collection and Handling



TABLE 5

## SUMMARY OF METHODS OF DUST UTILIZATION AND DISPOSAL

<u>Method</u>	<u>Number of Plants Reporting</u>	<u>% of 80 Plants<sup>a</sup> Reporting</u>
All dust returned to kiln	27	34
Surface piling (dry)	29	36
Returned to quarry (dry)	11	14
Leached	9	11
Slurried and discarded	7	9
Some sold or hauled away by contractor	8	10

a. Percentage total is greater than 100 because some plants report more than one method.

Data derived from RAPP applications, questionnaires, and plant visits.

SECTION IV  
INDUSTRY CATEGORIZATION

Introduction

In developing effluent limitations guidelines and standards of performance for new sources for a given industry, a judgment must be made as to whether separate effluent limitations and standards are appropriate for different segments (subcategories) within the industry. The appropriateness of potential subcategories for the cement manufacturing industry was evaluated on the basis of inherent differences in the characteristics and treatability of the effluent from plants segmented with respect to the following features.

Method of Dust Collection and Disposition

Type of Process (Wet or Dry)

Plant Age

Plant Size

Raw Materials

Type of Fuel

Auxiliary Operations

Products Produced

Plant Location

As a result of an intensive study of the waste water characteristics of about 80% of 166 plants in the industry, and an evaluation of the technology available for control and treatment of these wastes, it is concluded that the cement manufacturing industry should be divided into two subcategories based upon the method employed for dust collection and disposition.

Factors Considered

Method of Dust Collection and Disposition

All cement plants collect large amounts of kiln dust and must either reuse it or discard it. As discussed in Section III, if the alkali content is too high for direct return to the kiln, the dust is either leached or wasted. Whether wasted by means of wet slurring to a pond or by dry piling, contamination of surface waters can result from overflow of the pond or runoff from rain. Adequate methods of controlling or eliminating discharges from these sources are available.

In leaching operations, large volumes of water are generally involved and the waste loadings are much higher than in nonleaching plants, as shown in Figure 6. At the present time, no practical and completely effective methods of treating this water for reuse are available. Plants that use wet scrubbers for the collection of kiln dust employ even larger quantities of water, which may become contaminated by soluble materials.

Thus, based on the significant differences in waste loadings and treatability of the waste waters, subcategories for leaching and nonleaching plants are defined:

- leaching plants, in which the kiln dust comes into direct contact with water in the leaching of kiln dust for reuse or in the wet scrubbing of dust to control stack emissions.
- nonleaching plants, in which contamination of water is not inherently associated with the water usage.

A third subcategory, materials storage piles runoff, was added as a result of comments received from industry during public review of the proposed regulations and the Development Document for Proposed Effluent Limitations Guidelines and New Source Performance Standards for the Cement Manufacturing Point Source Category.

This subcategory defines plants within either the leaching or nonleaching subcategories which pile materials such as kiln dust, clinker, coal or other materials that are subject to rainfall runoff.

#### Type of Process

As described in Section III of this report, there are two basic processes for the manufacture of portland cement: the wet process in which the raw materials are slurried with water before being fed to the kiln and the dry process in which the raw materials are ground and fed to the kiln without use of water. A review of the characteristics of the waste water and inspections of both types of processes, indicate that the type of process need not have a direct effect on the quality of the waste water. Table 6 shows the average loading of several selected parameters for wet- and dry process plants and the percentage of plants of each type that report less than 0.005 kg per metric ton (0.01 lb/ton) of cement produced. The average loadings for wet-process plants are slightly greater, due to the high loadings of the leaching plants, almost all of which are wet, but the average is still relatively low. Moreover, a significant number of plants in both groups report very low loadings.

As discussed in Section VII, the two different processes offer basically different options for water management and reuse. However, acceptable options are available for both types of processes. Any difference that may exist in the cost of implementing these options is likely to vary as much among plants of the same type of process as among plants of

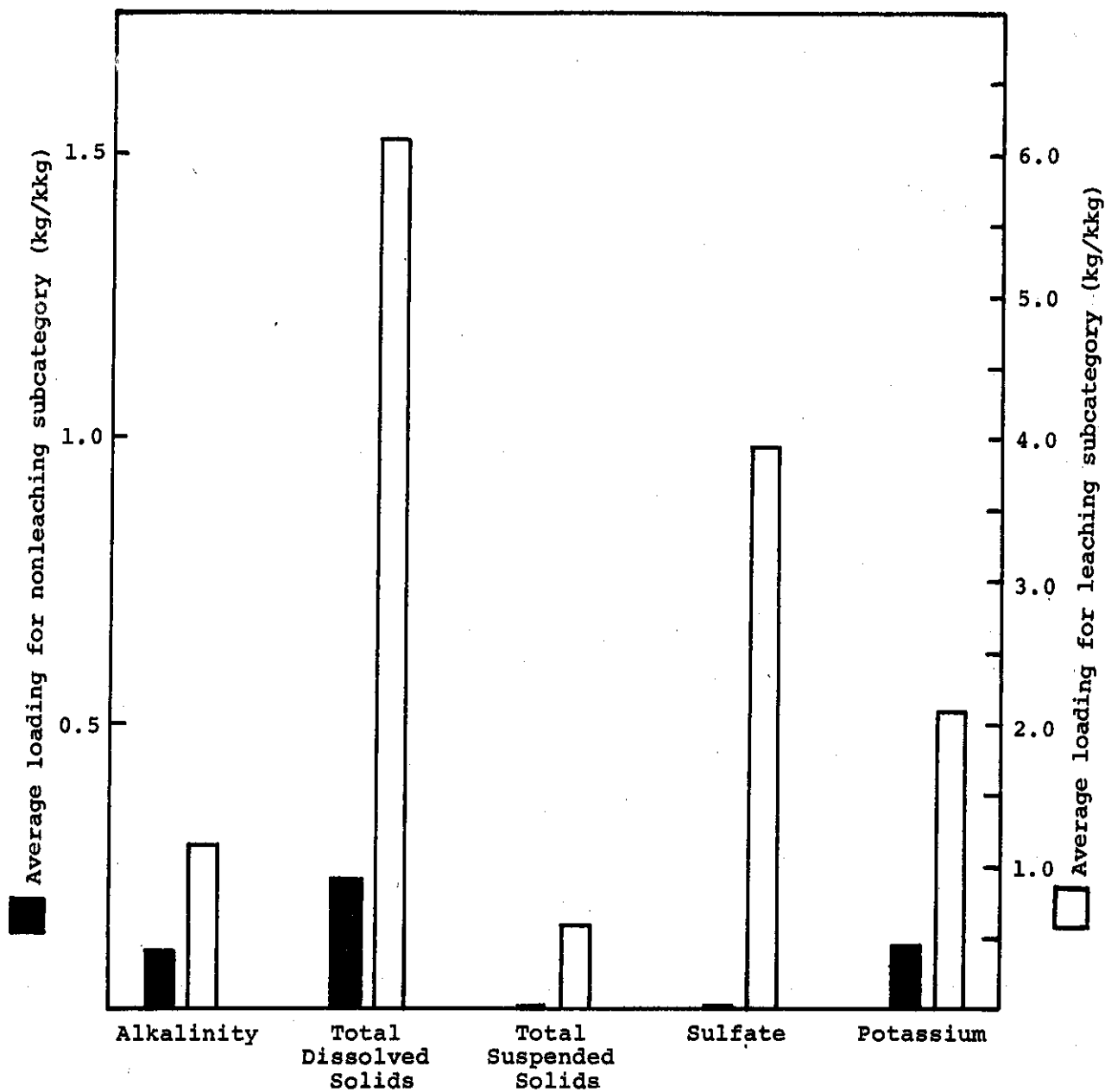

Figure 6. Comparison of Loadings of Selected Parameters for Leaching and Nonleaching Plants

Data derived from 88 RAPP applications.

TABLE 6

## COMPARISON OF LOADINGS OF SELECTED PARAMETERS FOR WET- AND DRY-PROCESS PLANTS

Parameter	Wet-Process Plants <sup>a</sup>		Dry-Process Plants <sup>b</sup>	
	Average, kg/kkg (lb/ton) of product	Percent of Total Reporting Less Than 0.005 kg/kkg product	Average, kg/kkg (lb/ton) of product	Percent of Total Reporting Less Than 0.005 kg/kkg product
Alkalinity	0.394 (0.79)	50	0.096 (0.19)	75
Total Dissolved Solids	1.723 (3.45)	36	0.611 (1.22)	32
Total Suspended Solids	0 (0)	38	0 (0)	74
Sulfate	0.535 (1.07)	50	0 (0)	67
Potassium	1.075 (2.15)	46	0.040 (0.08)	50

a. Includes 9 leaching plants.

b. Includes 1 leaching plant.

different types of process. Therefore, wet- and dry-process plants may be included in either subcategory.

#### Plant Age

Portland cement plants range in age from 2 years to more than 75 years since initial plant start-up. Analysis of the reported start-up dates for plants representing 75% of the establishments in the industry indicates that 16% of the plants are less than 10 years old while 37% of the plants are less than 20 years old, and about 32% of the plants are more than 50 years old. Analysis of the quantity of water used and the waste water constituents with respect to plant age shows no correlation between plant age and either the volume of water used or the waste water characteristics. There are probably two basic reasons for this lack of correlation: first, the basic process for the manufacture of portland cement has changed little in the last 50 years; and second, cement plants in general are constantly undergoing updating and modification. Thus, a plant that was constructed in 1906 may be operating with kilns and other equipment that are identical to those in a recently constructed plant. Therefore, plants of different ages may be included in either subcategory.

#### Plant Size

Analysis of the available data and inspection of plants of various sizes indicate that there is no correlation between plant size and the quality of waste waters as shown in Table 7. The lowest and highest average values for alkalinity and total solids are within one standard deviation. Also shown in the table are the gross water discharged and the water discharged per ton of product, which vary widely among the large and small plants with no obvious relationship to plant size. While a smaller plant may, through water conservation and good management practices, consume and discharge far less water, this is not necessarily the case. Differences in the amount of water discharged and possible requiring treatment may be reflected in higher costs of control and treatment technology; however, since such differences are not directly relatable to plant size, plants of all sizes may be included in either subcategory.

#### Raw Materials

As discussed in Section III, the raw materials required for the manufacture of portland cement are chemically similar, including the oyster shell used at a small number of plants located along the Gulf Coast. Analysis of the available data and on-site studies of exemplary plants indicate that with the exception of alkali content, which will be discussed below, only minor differences in the quantity or quality of waste water may be related to the type of raw materials used.

The raw materials that are available to some plants, especially limestone and clay, may contain higher-than-average amounts of potassium and sodium. These differences will be reflected in the waste water streams only at those plants where the kiln dust comes in contact with

TABLE 7

COMPARISON OF AVERAGE LOADINGS AND WATER DISCHARGED FOR  
PLANTS OF DIFFERENT CAPACITY

Rated Annual Capacity, 1000 kkg (Thousand tons)	Akalinity			Total Solids		
	Number of Plants Reporting	Average kg/kkg (lb/ton) of product	Standard deviation kg/kkg (lb/ton) of product	Number of Plants Reporting	Average kg/kkg (lb/ton) of product	Standard deviation kg/kkg (lb/ton) of product
All plants	75	0.283 (0.57)	0.879 (1.76)	76	1.491 (2.98)	3.363 (6.73)
0-270 (0-300)	10	0.244 (0.49)	0.392 (0.78)	10	1.456 (2.91)	2.086 (4.17)
270-450 (300-500)	26	0.263 (0.53)	0.930 (1.86)	26	1.515 (3.03)	3.425 (6.85)
450-900 (500-1000)	33	0.361 (0.72)	1.045 (2.09)	34	1.569 (3.14)	3.662 (7.32)
over 900 (over 1000)	6	0.013 (0.03)	0.147 (0.29)	6	1.568 (3.14)	3.856 (7.71)

## Water Discharged

Rated Annual Capacity, 1000 kkg (thousand tons)	Number of Plants Reporting	10 <sup>6</sup> l/day (mgpd)		l/kkg (gal/ton) of product	
		Average	Standard Deviation	Average	Standard Deviation
All plants	117	7.9 (2.1)	27 (7.2)	5,103 (1,760)	12,268 (4,220)
0-270 (0-300)	18	2.7 (0.7)	7.3 (1.9)	4,075 (1,400)	11,638 (4,000)
270-450 (300-500)	38	3.3 (0.9)	8.8 (2.3)	3,807 (1,310)	9,244 (3,180)
450-900 (500-1000)	53	8.5 (2.2)	18.3 (4.8)	6,076 (2,090)	14,115 (4,850)
over 900 (over 1000)	8	36.4 (9.6)	9 (2.4)	7,116 (2,450)	14,474 (5,070)

Data derived from 88 RAPP applications and 29 questionnaires.

the waste stream. Plants where such contact is purposeful rather than incidental have already been considered as a separate subcategory. Thus, the type of raw material is considered with respect to its influence on dust handling techniques, and as such is covered in the leaching and nonleaching subcategories.

#### Fuel

Few plants use only one type of fuel. The type of fuel burned may affect the amount of water-soluble constituents in the kiln dust; and minor differences may be found in the waste water characteristics of plants using different fuels, if the kiln dust comes in contact with the water. These differences are considered in the defined subcategories. Leaching of coal piles by rainfall and subsequent runoff may be a problem at some coal-burning plants, however, adequate methods for controlling such runoff are available in other industries that have large coal storage piles. Such methods include spraying the piles with latex films that prevent moisture from entering the piles, and diking the coal-pile combined with lime or limestone neutralization to prevent discharge of acidic runoff water.

#### Ancillary Operations

As discussed in Section III, cement plants may conduct activities not directly concerned with the manufacture of portland cement. These activities include the generation of electric power from boilers heated by waste kiln heat, the washing of bulk hauling trucks, the cleaning of slurry tanks, the blowing-down of cooling towers, air compressors, and boilers, and the beneficiation and washing of raw material.

Power generation by waste-heat boilers is limited to only a few plants. While this operation could provide a basis for separate consideration, pollutants in waters arising from this activity are intended to be covered by effluent guideline document and regulations promulgated separately at a future date by EPA.

The other activities are practiced to some extent at most plants, and the characteristics of waste waters arising from such activities are common to the industry as a whole which precludes consideration of auxiliary operations as a basis for subcategorization.



## Products Produced

Different types of portland cement are produced by either varying the raw material mix and manufacturing conditions or blending additives with the cement after the clinker has been ground. There are only minor variations in the manufacturing process for making different products. Several types of products may also be made at different times at the same facility. With the exception of low-alkali cement produced from high-alkali raw materials, the general waste characteristics will be the same, irrespective of the type of cement being produced. Low-alkali cement production affects water quality only at leaching plants and is thus already considered.

## Plant Location

Wastewater quality was not found to be related to geographical location. Some variation may exist in regions of the country where the only available raw materials are highly alkaline, but this factor was considered under raw materials. Thus, geographical location is not a suitable basis for subcategorization.

The local topography as reflected by the availability of land or an adjacent quarry that may be used for waste water disposal varies considerably from plant to plant. However, since other options, discussed in Section VII, are available, topological considerations are not a reasonable basis for subcategorization.

## Materials Storage Piles

During the data gathering phase of the study which included visits to specific plants in the industry, the contractor and Agency representatives observed that in most cases materials storage piles i.e. kiln dust, raw material, clinker and coal were either situated on the plant property or contained in such a manner so that rainfall runoff from the piles would not discharge to nearby waters.

As discussed in the original version of this document, kiln dust piles, coal and materials piles could be contained or treated (latex spraying, etc.) to prevent runoff from carrying pollutants into nearby waters. However, as was aptly pointed out during the comment period, not all plants in the industry are able to completely prevent runoff discharges and none could be expected to contain all the runoff from the piles during abnormal rainfall events and cataclysmic climatic conditions. Therefore, it became necessary to further subcategorize the industry for the purpose of identifying the appropriate control technologies and to establish pollutant discharge limitations for materials storage piles runoff which are practicable and economically achievable.

## SECTION V

### WATER USE AND WATER CHARACTERIZATION

#### General

The operations where the largest volumes of water are used in cement plants are essentially nonpolluting. Process water in wet plants is evaporated; most cooling water is not contaminated; the change usually noted is an increase in temperature.

Any contaminated discharges contain constituents that are present in the raw materials, collected kiln dust, or cement dust. These constituents, which include aluminum, iron, calcium, magnesium, sodium, potassium, sulfate, and chloride, may occur in any water that has contact with these materials.

The presence of these constituents will be reflected as total dissolved solids, total suspended solids, and high pH and alkalinity.

Other constituents, reported as BOD, COD, Kjeldahl nitrogen, total volatile solids, and phenols, have been noted in the effluents of some plants. However, these are related to the presence of organic materials not directly related to the process of cement manufacture, but arising from sanitary effluents, spills of fuel oil, runoff from coal piles, and drainage from quarries, settling ponds and cooling ponds, which may contain decayed vegetation.

Plants in the leaching subcategory have a higher pollutant loading than other plants. This is illustrated by the average loading for six selected parameters in Figure 6 and for 35 parameters reported in 88 RAPP applications in Table 8 for plants in both subcategories.

#### Specific Water Uses and Waste Characteristics

Water usage for the cement industry is summarized in Table 9 and in the flow diagrams in Figure 7. These uses and the characteristics of the associated discharges are discussed below.

##### Cooling Water

The major use of water at most cement plants is for cooling. This water is used to cool bearings on the kiln and grinding equipment, air compressors, burner pipes and the cooling of cement prior to storage or shipment. A summary of average volumes of cooling water used for specific purposes is given in Table 10.

While cooling water is mostly noncontact, it can become contaminated to some extent through poor water management practices. This contamination may include oil and grease, suspended solids, and even some dissolved solids. If cooling towers are used, blow down discharges may contain residual algicides.

Data derived from 71 RAPP applications.

TABLE 8  
COMPARISON OF WASTE LOADINGS FOR LEACHING AND NONLEACHING  
SUBCATEGORIES AS REPORTED

Parameter	Units	Mean Value for Leaching Subcategory	Number of Plants	Mean Value for Non- leaching Subcategory	Number of Plants
Alkalinity	kg/kkg (lb/ton)	1.381 (2.76)	10	0.087 (0.17)	61
BOD, 5 day	kg/kkg (lb/ton)	0 (0)	9	0 (0)	57
COD	kg/kkg (lb/ton)	0.032 (0.06)	9	0 (0)	53
Total Solids	kg/kkg (lb/ton)	7.495 (14.99)	10	0.314 (0.63)	61
Total Dissolved Solids	kg/kkg (lb/ton)	6.622 (13.24)	10	0.272 (0.54)	60
Total Suspended Solids	kg/kkg (lb/ton)	0.906 (1.81)	10	0 (0)	58
Total Volatile Solids	kg/kkg (lb/ton)	0.825 (1.65)	8	0 (0)	57
Ammonia	kg/kkg (lb/ton)	0 (0)	8	0 (0)	53
Kjeldahl Nitrogen	kg/kkg (lb/ton)	0 (0)	8	0 (0)	52
Nitrate Nitrogen	kg/kkg (lb/ton)	0 (0)	8	0 (0)	53
Phosphorus	kg/kkg (lb/ton)	0 (0)	8	0 (0)	55
Oil and Grease	kg/kkg (lb/ton)	0 (0)	4	0 (0)	47
Chloride	kg/kkg (lb/ton)	1.202 (2.40)	6	0 (0)	56
Sulfate	kg kkg (lb/ton)	3.667 (7.33)	6	0 (0)	56
Sulfide	kg kkg (lb/ton)	0 (0)	4	0 (0)	41
Sulfite	kg/kkg (lb/ton)	- -	0	0 (0)	5
Phenols	g/kkg (.001 lb/ton)	0 (0)	4	0 (0)	47
Chromium	g/kkg (.001 lb/ton)	0.080 (0.16)	6	0 (0)	51
Acidity	kg/kkg (lb/ton)	- -	0	0 (0)	6
Total Organic Carbon	kg/kkg (lb/ton)	- -	0	0 (0)	4
Total Hardness	kg/kkg (lb/ton)	2.207 (4.41)	4	0.864 (1.73)	21
Flouride	kg/kkg (lb/ton)	0 (0)	1	0 (0)	5
Aluminum	g/kkg (.001 lb/ton)	0.638 (1.28)	3	0.009 (0.02)	10
Calcium	kg/kkg (lb/ton)	0.965 (1.93)	4	0.094 (0.19)	18
Copper	g/kkg (.001 lb/ton)	- -	0	0 (0)	5
Iron	g/kkg (.001 lb/ton)	4.765 (9.53)	3	0.156 (0.31)	15
Lead	g/kkg (.001 lb/ton)	0.990 (1.98)	2	0 (0)	3
Magnesium	kg/kkg (lb/ton)	0.014 (0.03)	4	0.156 (0.31)	15
Mercury	g/kkg (.001 lb/ton)	- -	0	0 (0)	3
Nickel	g/kkg (.001 lb/ton)	- -	0	0 (0)	4
Potassium	kg/kkg (lb/ton)	3.298 (6.60)	4	0.077 (0.15)	11
Sodium	kg/kkg (lb/ton)	0.371 (0.74)	4	0.238 (0.48)	12
Zinc	g/kkg (.001 lb/ton)	0 (0)	2	0 (0)	9

TABLE 9  
SUMMARY OF WATER USAGE FOR THE CEMENT INDUSTRY

<u>Use</u>	<u>Number of Plants</u>	<u>Average</u>	<u>Reported Flow Minimum</u>	<u>Maximum</u>	<u>Units</u>
Cooling	117	1,550 (450)	17 (5)	72,000 (21,000)	l/kgg of Product (gal/ton)
Raw Material Washing and Beneficiation	4	100	2.1	405	l/kgg of Raw Material
Process	78	(29) 860	(0.7) 246	(108) 1,740	(gal/ton) l/kgg of Product
Dust Control	13	(250) 264,000	(72) 1,890	(510) 600,000	(gal/ton) l/day
Dust Leaching	7	(70,000) 6,750	(500) 5,300	(159,000) 11,500	(gal/day) l/kgg of Dust
Dust Disposal	5	(1620) 190	(1270) 7.9	(2760) 490	(gal/ton of dust) l/kgg of Product
Wet Scrubber	3	(55) 28,000	(2.3) 4,150	(140) 42,500	(gal/ton) l/kgg of Product
		(8,100)	(1,200)	(12,300)	(gal/ton)

Data derived from 88 RAPP applications and 29 questionnaires.

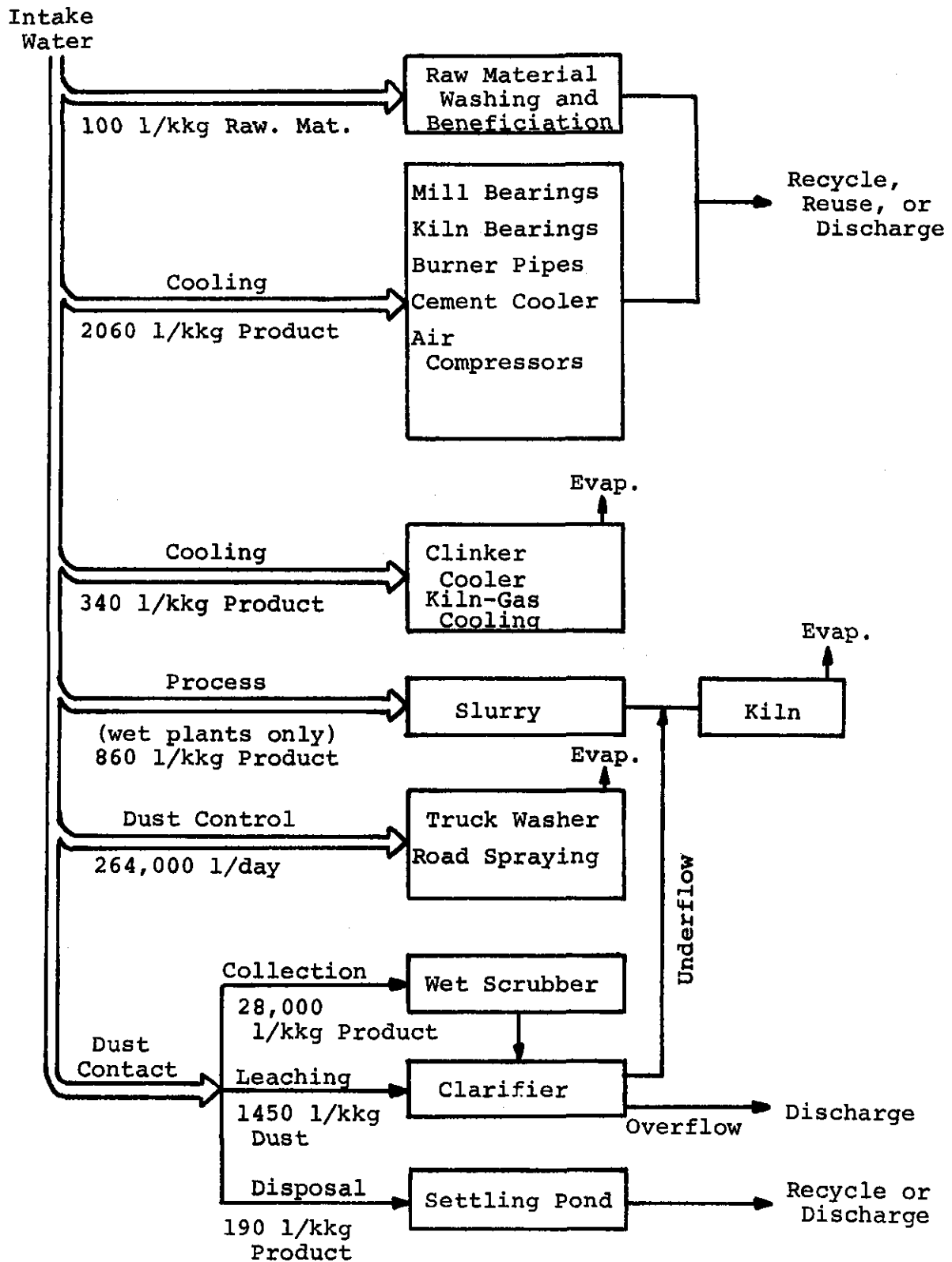

Figure 7. Diagram of Water Usage in Cement Manufacturing.

TABLE 10  
 REPORTED COOLING WATER USAGE IN CEMENT PLANTS

<u>Use</u>	<u>Average Flow, l/kgg (gal/ton) Product</u>	<u>Number of Plants</u>	<u>Range</u>	
			<u>Minimum</u>	<u>Maximum</u>
Bearing cooling	1,080 (284)	39	3.8 (1.0)	5,800 (1,530)
Cement Cooling	760 (200)	22	1.9 (0.5)	3,750 (985)
Clinker cooling	60 (23)	12	2.1 (0.6)	242 (64)
Kiln-gas cooling	322 (85)	4	92 (24)	770 (203)
Burner-pipe cooling	265 (70)	2	258 (68)	272 (72)

Data derived from 39 questionnaires.

### Slurry Water

For purposes of this discussion, slurry water is defined as the water used at wet plants to feed the raw material to the kiln. This water is subsequently evaporated in the kiln and, therefore, does not constitute a discharge.

The relatively constant volume of water used in the preparation of slurry averages 860 l/kg (260 gal/ton). At a few plants, excess water containing a high concentration of suspended solids is discharged from the slurry thickeners. This practice constitutes a nonessential discharge and is easily avoided by recycling this water for making the slurry. Other losses of slurry may occur due to poor maintenance of pumps, which become worn and develop leaky seals. The resulting spillage may result in a waste discharge with high solids if not controlled.

### Kiln-Dust-Contact Water

There are three operations in which water contacts collected kiln dust. The waste water generated by plants with these operations constitutes the highest loadings of pollutants within the industry.

The most significant of these operations is the leaching (removal) of soluble alkalies from the collected dust so that the dust may be returned to the kiln as recovered raw material. This operation occurs at about nine plants. In all cases the overflow (leachate) from this operation is discharged, sometimes without treatment. The waste waters from this operation are essentially identical for all plants, varying to some extent in the concentration of individual constituents because of differences in raw materials at each plant. These constituents include high pH, alkalinity, suspended solids, dissolved solids, potassium, and sulfate.

The second most common operation is the wet disposal of dust. In this operation a slurry is also made of the collected kiln dust and fed to a pond, where the solids settle out. The settled solids are not recovered for return to the kiln, and the overflow (leachate) may be discharged. The constituents of this discharge are essentially the same as those from the leaching operation. At least five plants use this wet method to dispose of collected kiln dust and the volume of water used ranges from 70,000 to 760,000 l/day (18,000 to 200,000 gal/day).

The use of wet scrubbers for air pollution control constitutes the third example of water in direct contact with the kiln dust. At least three plants in the industry use wet scrubbers to collect kiln dust from effluent gases.

### Other Water Uses

All cement plants have some accumulation of settled dust on the plant property and this dust may show up in the waste water in a number of ways. Many plants spray water on the roads to prevent the dust from

becoming air-borne by truck traffic. Most plants also routinely wash accumulated dust off the trucks. At some plants, certain parts of the plant areas are also washed down to remove accumulated dust. The amount of water used for these purposes varies widely, ranging from 950 to 9500 l/day (250 to 2500 gal/day) as reported in a sample of 12 plants. Some of this water undoubtedly evaporates, but depending on the topography of the plants, some of this water may drain into storm sewers or natural waterways.

Water from surface runoff after rain may also be laden with the dust that accumulates on the plant site. Runoff from dust piles, coal piles, and raw material piles may also become contaminated. Plants with boilers, cooling towers, and intake water-treatment facilities, have blowdown and backwash discharges associated with these operations.

At some plants, raw materials are washed and at others the raw materials are enriched by a beneficiation process; these processes may result in waste water discharges containing suspended solids.

Where an active or abandoned quarry is used as a receiving basin for dust disposal or plant waste water, the discharge from the quarry may be contaminated with wastes associated with cement manufacturing. However, where a quarry is used exclusively for the production of raw material, discharge of any accumulated water (dewatering) is not considered in this report but is intended to be considered in a subsequent EPA effluent guidelines study of the mineral mining industry. For nonleaching plants the average net loading of suspended solids is less than zero, indicating that more solids are removed from the intake water used in the plant than are added by the process. However, 4 of the 58 plants of this group report over 1 kg/kg (2 lb/ton) of product indicating a moderate level of suspended solids is possible, if not properly controlled.

For leaching plants the average discharge of suspended solids is 0.9 kg/kg (1.8 lb/ton) of product.





## SECTION VI

### SELECTION OF POLLUTANT PARAMETERS

#### Definition of Pollutants

Section 502 of the Federal Water Pollution Control Act Amendments of 1972 defines pollution as "...the man-induced alteration of the chemical, physical, biological, and radiological integrity of the water." The term pollutant is defined as "industrial, municipal, and agricultural waste discharged into water."

For purposes of this report pollutants are defined as chemical, physical, or biological constituents of discharged water that are added in quantities, measurable by routine analytical procedures, greater than 0.005 kg/kg (0.01 lb/t) of product as a result of the water being used in manufacturing operations characteristic of the industry. For example, a plant with a discharge flow of 8.3 million liters per day (2.2 mgpd) and a daily production of 1420 kkg/day (1560 t/day) (average values for the industry) a loading of 0.005 kg/kg of product would result in a concentration of less than 1 mg/l in the discharged effluent.

At some plants, other constituents may be added as a result of operations that are not unique to the industry, but are considered pollutants as defined in the Act. Pollutants from these sources may be subject to limitations on an individual plant basis, or to limitations developed for other point sources.

#### Pollutant Parameters

Based on information on 35 parameters, listed in Table 8, as reported in the RAPP Applications of 88 plants and analysis of waste water at 10 plants, seven constituents have been identified as pollutants for the cement industry. These constituents are present in the waste streams of plants in both subcategories and are subject to the limitations recommended in this report. Table 11 presents the relevant data on each of these parameters, listed below, for plants in both subcategories.

1. pH
2. Total dissolved solids
3. Total suspended solids
4. Alkalinity and Acidity
5. Potassium
6. Sulfate
7. Temperature (Heat)

#### Rationale for Selection of Specific Parameters as Pollutants

##### pH, Acidity and Alkalinity

TABLE 11

## LOADINGS OF POLLUTANT PARAMETERS FOR LEACHING AND NONLEACHING PLANTS

Parameter	Units Loading/Product	Number of Plants Reporting	Leaching Plants				Nonleaching Plants					
			Mean Value	Standard Deviation	Minimum		Maximum	Number of Plants Reporting	Mean Values	Standard Deviation	Minimum	Maximum
pH		11	9.9	2.125	6.0		12.0	77	8.2	1.011	6.0	12.3
Total Dissolved Solids	kg/kkg (lb/ton)		6.621 (13.24)	3.260 (6.52)	0.056 (0.11)		13.056 (26.11)	60	0.272 (0.54)	1.374 (2.75)	0 (0)	7.870 (15.74)
Total Suspended Solids	kg/kkg (lb/ton)	10	0.906 (1.81)	1.552 (3.10)	0	0	4.497 (8.99)	58	0	4.114 (8.23)	0 (0)	7.337 (14.67)
Alkalinity	kg/kkg (lb/ton)	10	1.381 (2.76)	1.307 (2.61)	0	0	4.013 (8.02)	61	0.087 (0.17)	0.628 (1.26)	0 (0)	3.866 ( 7.73)
Potassium	kg/kkg (lb/ton)	4	3.298 (6.59)	4.624 (9.25)	0.178 (0.36)		11.291 (22.58)	11	0.078 (0.16)	0.389 (0.78)	0 (0)	1.212 ( 2.42)
Sulfate	kg/kkg (lb/ton)	6	6.667 (13.33)	5.413 (10.83)	0.614 (1.23)		15.677 (31.35)	56	0	0.448 (0.90)	0 (0)	1.619 ( 3.24)
Temperature Rise	°C °F	9	4.45 (8.0)	3.525 (6.3)	0	0	11.0 (19.8)	58	4.53 (8.2)	3.51 (6.3)	0 (0)	17.0 (30.6)

Data derived from 88 RAPP applications.

Acidity and alkalinity are reciprocal terms. Acidity is produced by substances that yield hydrogen ions upon hydrolysis and alkalinity is produced by substances that yield hydroxyl ions. The terms "total acidity" and "total alkalinity" are often used to express the buffering capacity of a solution. Acidity in natural waters is caused by carbon dioxide, mineral acids, weakly dissociated acids, and the salts of strong acids and weak bases. Alkalinity is caused by strong bases and the salts of strong alkalies and weak acids.

The term pH is a logarithmic expression of the concentration of hydrogen ions. At a pH of 7, the hydrogen and hydroxyl ion concentrations are essentially equal and the water is neutral. Lower pH values indicate acidity while higher values indicate alkalinity. The relationship between pH and acidity or alkalinity is not necessarily linear or direct.

Waters with a pH below 6.0 are corrosive to water works structures, distribution lines, and household plumbing fixtures and can thus add such constituents to drinking water as iron, copper, zinc, cadmium and lead. The hydrogen ion concentration can affect the "taste" of the water. At a low pH water tastes "sour". The bactericidal effect of chlorine is weakened as the pH increases, and it is advantageous to keep the pH close to 7. This is very significant for providing safe drinking water.

Extremes of pH or rapid pH changes can exert stress conditions or kill aquatic life outright. Dead fish, associated algal blooms, and foul stenches are aesthetic liabilities of any waterway. Even moderate changes from "acceptable" criteria limits of pH are deleterious to some species. The relative toxicity to aquatic life of many materials is increased by changes in the water pH. Metalocyanide complexes can increase a thousand-fold in toxicity with a drop of 1.5 pH units. The availability of many nutrient substances varies with the alkalinity and acidity. Ammonia is more lethal with a higher pH.

The lacrimal fluid of the human eye has a pH of approximately 7.0 and a deviation of 0.1 pH unit from the norm may result in eye irritation for the swimmer. Appreciable irritation will cause severe pain.

Because of the water soluble alkalies in cement dust, any effluent contaminated with dust will have an alkaline pH. Average pH values range from 8.2 for nonleaching plants to 9.9 for plants in the leaching subcategory. Figure 8 shows the distribution of maximum reported pH for 88 plants.

Likewise the water soluble alkalies in kiln dust piles can contribute to high pH values of the runoff from such piles.

Low pH values are attributed to the soluble acidic components of coal pile runoff (56). pH values less than 4.0 are frequently observed.

#### Total Dissolved Solids

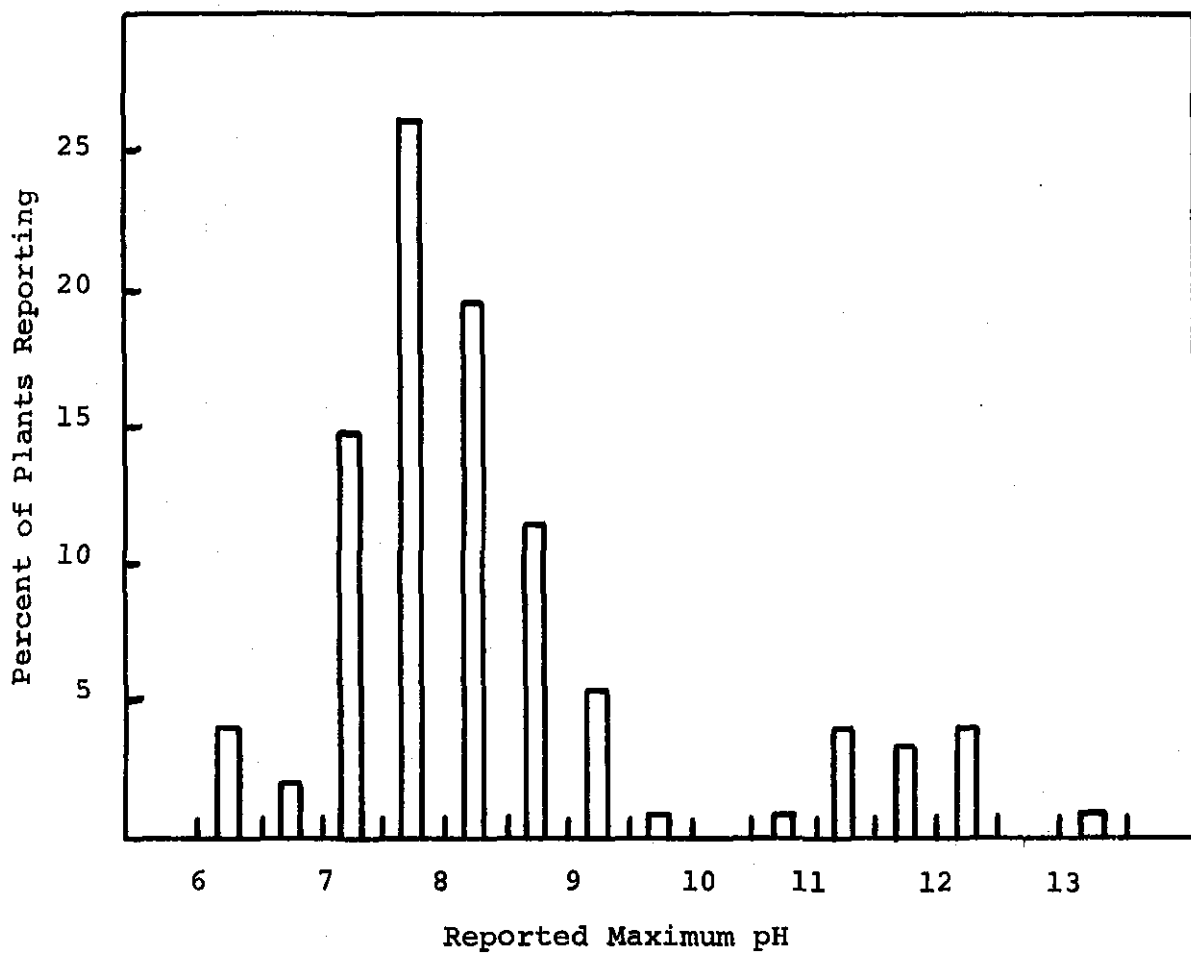

Figure 8. Distribution of Reported Maximum pH

Dissolved Solids are present in effluent waters that have contact with dust. Average loading of dissolved solids is 0.27 kg/kg (0.54 lb/ton) of product for nonleaching plants and 6.6 kg/kg (13.2 lb/ton) for leaching plants.

In natural waters the dissolved solids consist mainly of carbonates, chlorides, sulfates, phosphates, and possibly nitrates of calcium, magnesium, sodium, and potassium, with traces of iron, manganese and other substances.

Many communities in the United States and in other countries use water supplies containing 2000 to 4000 mg/l of dissolved salts, when no better water is available. Such waters are not palatable, may not quench thirst, and may have a laxative action on new users. Waters containing more than 4000 mg/l of total salts are generally considered unfit for human use, although in hot climates such higher salt concentrations can be tolerated whereas they could not be in temperate climates. Waters containing 5000 mg/l or more are reported to be bitter and act as bladder and intestinal irritants. It is generally agreed that the salt concentration of good, palatable water should not exceed 500 mg/l.

Limiting concentrations of dissolved solids for fresh-water fish may range from 5,000 to 10,000 mg/l, according to species and prior acclimatization. Some fish are adapted to living in more saline waters, and a few species of fresh-water forms have been found in natural waters with a salt concentration of 15,000 to 20,000 mg/l. Fish can slowly become acclimatized to higher salinities, but fish in waters of low salinity cannot survive sudden exposure to high salinities, such as those resulting from discharges of oil-well brines. Dissolved solids may influence the toxicity of heavy metals and organic compounds to fish and other aquatic life, primarily because of the antagonistic effect of hardness on metals.

Waters with total dissolved solids over 500 mg/l have decreasing utility as irrigation water. At 5,000 mg/l water has little or no value for irrigation.

Dissolved solids in industrial waters can cause foaming in boilers and cause interference with cleanliness, color, or taste of many finished products. High contents of dissolved solids also tend to accelerate corrosion.

Specific conductance is a measure of the capacity of water to convey an electric current. This property is related to the total concentration of ionized substances in water and water temperature. This property is frequently used as a substitute method of quickly estimating the dissolved solids concentration. Total Suspended Solids

#### Total Suspended Solids

Suspended solids include both organic and inorganic materials. The inorganic components include sand, silt, and clay. The organic fraction

includes such materials as grease, oil, tar, animal and vegetable fats, various fibers, sawdust, hair, and various materials from sewers. These solids may settle out rapidly and bottom deposits are often a mixture of both organic and inorganic solids. They adversely affect fisheries by covering the bottom of the stream or lake with a blanket of material that destroys the fish-food bottom fauna or the spawning ground of fish. Deposits containing organic materials may deplete bottom oxygen supplies and produce hydrogen sulfide, carbon dioxide, methane, and other noxious gases.

In raw water sources for domestic use, state and regional agencies generally specify that suspended solids in streams shall not be present in sufficient concentration to be objectionable or to interfere with normal treatment processes. Suspended solids in water may interfere with many industrial processes, and cause foaming in boilers, or encrustations on equipment exposed to water, especially as the temperature rises. Suspended solids are undesirable in water for textile industries; paper and pulp; beverages; dairy products; laundries; dyeing; photography; cooling systems, and power plants. Suspended particles also serve as a transport mechanism for pesticides and other substances which are readily sorbed into or onto clay particles.

Solids may be suspended in water for a time, and then settle to the bed of the stream or lake. These settleable solids discharged with man's wastes may be inert, slowly biodegradable materials, or rapidly decomposable substances. While in suspension, they increase the turbidity of the water, reduce light penetration and impair the photosynthetic activity of aquatic plants.

Solids in suspension are aesthetically displeasing. When they settle to form sludge deposits on the stream or lake bed, they are often much more damaging to the life in water, and they retain the capacity to displease the senses. Solids, when transformed to sludge deposits, may do a variety of damaging things, including blanketing the stream or lake bed and thereby destroying the living spaces for those benthic organisms that would otherwise occupy the habitat. When of an organic and therefore decomposable nature, solids use a portion or all of the dissolved oxygen available in the area. Organic materials also serve as a seemingly inexhaustible food source for sludgeworms and associated organisms.

Turbidity is principally a measure of the light absorbing properties of suspended solids. It is frequently used as a substitute method of quickly estimating the total suspended solids when the concentration is relatively low.

Since cement dust is dense and tends to settle out rapidly, suspended solids may be removed from the waste waters before leaving the plant property.

For nonleaching plants the average net loading of suspended solids is zero. However, 4 of the 58 plants of this group report over 1 kg/kg (2

lb/ton) of product indicating a moderate level of suspended solids is possible, if not properly controlled.

For leaching plants the average discharge of suspended solids is 0.9 kg/kg (1.8 lb/ton) of product.

For materials storage piles runoff the suspended solids levels can far exceed those associated with the leaching and nonleaching operation. The sources include kiln dust, coal, clinker and other materials storage exposed to rainfall and subject to runoff discharge to nearby waterbodies.

#### Alkalinity

Because of their highly buffered nature, the effluents from cement plants can have a relatively low pH and still have considerable alkalinity. The average loading for nonleaching plants is 0.09 kg/kg (0.18 lb/ton) of product.

For leaching plants the average loading is considerably higher, 1.38 kg/kg (2.8 lb/ton) of product.

#### Acidity

Acidity is associated with the runoff from coal storage piles exposed to rainfall. The nature of the pollutant is similar to acid mine drainage and can be observed as a brownish-yellow discharge commonly called "yellow boy". Although no specific data was collected on coal storage piles runoff at cement plants, the Agency's experience in controlling acid mine drainage discharges substantiate the need to control similar discharges regardless of their source. The acidity will manifest itself as a low pH, 4.0 or below and will frequently result in the production of "yellow boy" which can be readily observed.

#### Potassium

Where potassium is present in the raw material in appreciable quantities, it will be the major soluble alkaline component of the kiln dust collected in air pollution control equipment. Thus, potassium salts will be found in water that has contact with the collected dust. This is confirmed by the fact that leaching plants report an average loading of 3.3 kg/kg (6.6 lb/ton) while other plants report 0.08 kg/kg (0.16 lb/ton).

#### Sulfate

Sulfate is present in the raw materials and some additional quantities may be formed in the kiln, at plants that burn sulfur-containing fuels. Average net loadings of sulfate are zero for nonleaching plants and 6.7 kg/kg (13.4 lb/ton) for leaching plants.

#### Temperature



Since all cement plants use cooling water, a temperature increase is a characteristic of the effluent of most cement plants. Because the quantity of water used for cooling varies considerably, and is distributed among a number of streams, the thermal pollution is calculated in terms of actual heat generated (cal/kg of product or BTU/ton) by dividing the increase in temperature by the daily production and multiplying by the daily flow and an appropriate constant. In these terms, the average thermal increase reported by 63 plants is 4800 kg cal/kg (17,200 BTU/ton)  $\pm$  4150 kg cal/kg (14,900 BTU/ton) of product. These numbers may be back-calculated using the average daily flow and production to give a typical temperature increase of 3°C (5.5°F). Eleven plants report a typical increase from 6 to 11°C (10 to 19°F). Figure 9 shows the calculated average temperature rise for 65 plants.

At some plants in the cement industry, thermal pollution must be considered as a significant parameter.

Temperature is one of the most important and influential water quality characteristics. Temperature determines those species that may be present; it activates the hatching of young, regulates their activity, and stimulates or suppresses their growth and development; it attracts, and may kill when the water becomes too hot or becomes chilled too suddenly. Colder water generally suppresses development. Warmer water generally accelerates activity and may be a primary cause of aquatic plant nuisances when other environmental factors are suitable.

Temperature is a prime regulator of natural processes within the water environment. It governs physiological functions in organisms and, acting directly or indirectly in combination with other water quality constituents, it affects aquatic life with each change. These effects include chemical reaction rates, enzymatic functions, molecular movements, and molecular exchanges between membranes within and between the physiological systems and the organs of an animal.

Chemical reaction rates vary with temperature and generally increase as the temperature is increased. The solubility of gases in water varies with temperature. Dissolved oxygen is decreased by the decay or decomposition of dissolved organic substances and the decay rate increases as the temperature of the water increases reaching a maximum at about 30°C (86°F). The temperature of stream water, even during summer, is below the optimum for pollution-associated bacteria. Increasing the water temperature increases the bacterial multiplication rate when the environment is favorable and the food supply is abundant.

Reproduction cycles may be changed significantly by increased temperature because this function takes place under restricted temperature ranges. Spawning may not occur at all because temperatures are too high. Thus, a fish population may exist in a heated area only by continued immigration. Disregarding the decreased reproductive potential, water temperatures need not reach lethal levels to decimate a

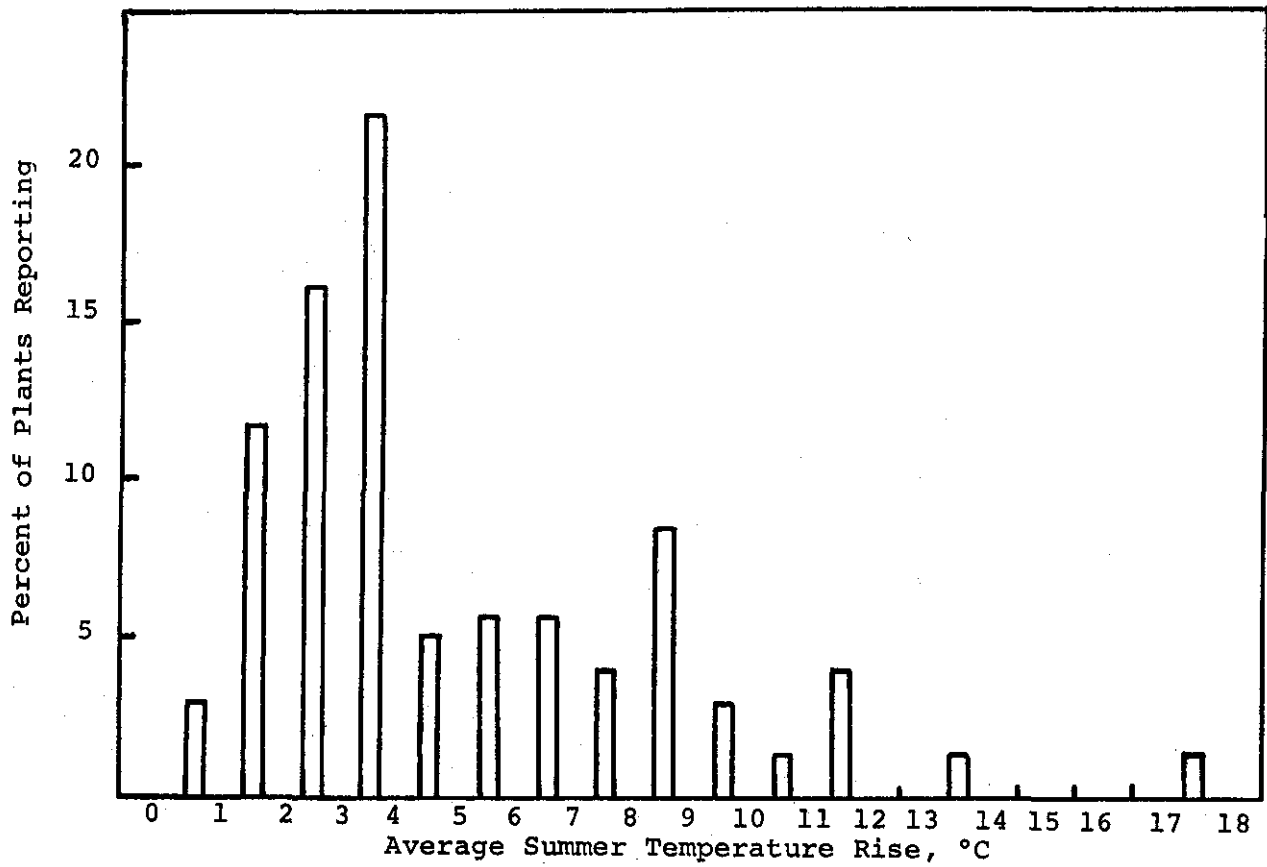

Figure 9. Distribution of Calculated Average Temperature Rise.

Data derived from 88 RAPP applications.

species. Temperatures that favor competitors, predators, parasites, and disease can destroy a species at levels far below those that are lethal.

Fish food organisms are altered severely when temperatures approach or exceed 90°F. Predominant algal species change, primary production is decreased, and bottom associated organisms may be depleted or altered drastically in numbers and distribution. Increased water temperatures may cause aquatic plant nuisances when other environmental factors are favorable.

Synergistic actions of pollutants are more severe at higher water temperatures. Given amounts of domestic sewage, refinery wastes, oils, tars, insecticides, detergents, and fertilizers more rapidly deplete oxygen in water at higher temperatures, and the respective toxicities are likewise increased.

When water temperatures increase, the predominant algal species may change from diatoms to green algae, and finally at high temperatures to blue-green algae, because of species temperature preferentials. Blue-green algae can cause serious odor problems. The number and distribution of benthic organisms decreases as water temperatures increase above 90°F, which is close to the tolerance limit for the population. This could seriously affect certain fish that depend on benthic organisms as a food source.

The cost of fish being attracted to heated water in winter months may be considerable, due to fish mortalities that may result when the fish return to the cooler water.

Rising temperatures stimulate the decomposition of sludge, formation of sludge gas, multiplication of saprophytic bacteria and fungi (particularly in the presence of organic wastes), and the consumption of oxygen by putrefactive processes, thus affecting the esthetic value of a water course.

In general, marine water temperatures do not change as rapidly or range as widely as those of freshwaters. Marine and estuarine fishes, therefore, are less tolerant of temperature variation. Although this limited tolerance is greater in estuarine than in open water marine species, temperature changes are more important to those fishes in estuaries and bays than to those in open marine areas, because of the nursery and replenishment functions of the estuary that can be adversely affected by extreme temperature changes.

#### Rationale for Rejection of Specific Parameters as Pollutants.

The following constituents were considered, but were not selected as pollutants for the reasons indicated:

BOD, Kjeldahl nitrogen, phenols, total organic carbon

These constituents are reported in the discharges for some cement plants. However, their occurrence is associated with nonmanufacturing discharges, such as sanitary effluent and drainage from quarries or

ponds where organic material could be present. Since they are largely identified with organic materials not associated with the manufacture of cement, they are not considered pollutants characteristic of this industry. The average loading of each of these constituents is less than 0.005 kg/kg (0.01 lb/ton).

Calcium, magnesium, sodium, aluminum, iron

These constituents are present in both the raw materials and the finished product; consequently they are sometimes found in the waste water generated by cement plants. Sodium and calcium are more prevalent in dust-contact streams. Since the presence of sodium and calcium will be reflected in the level of alkalinity and total dissolved solids, they will be indirectly measured and controlled by the limitations on these parameters.

Aluminum and iron compounds are normally found only in dust-contact streams and at relatively low loading levels and are included in consideration of total suspended solids and total dissolved solids.

Heavy metals (lead, chromium, cadmium, mercury, nickel, copper)

With the exception of lead and chromium, significant loadings of heavy metals have not been detected in the waste waters for the industry. In an apparently isolated case, lead is reportedly associated with the discharge of a single plant that uses oyster shell. Chromium is only present in the discharge of a few plants from non contact cooling water systems.

Turbidity, total hardness, total solids, total volatile solids, COD

These parameters are present in the waste waters of the industry, but are more accurately covered by inclusion with the parameters of suspended solids, dissolved solids and alkalinity.

Oil & grease, ammonia, nitrate (as N), phosphorus (as P), sulfide, sulfite, fluoride, zinc

These constituents are not normally present in the waste waters from cement plants. Oil and grease can occur from leakage of bearings in cooling-water streams. However, the average loading of this and the other parameters in this group is less than 0.005 kg/kg (0.1 lb/ton) of product for the industry.



## SECTION VII

### CONTROL AND TREATMENT TECHNOLOGY

#### Introduction

There are relatively few operations in cement manufacturing where the addition of pollutants to the water used is inherently associated with the use of that water. For most of the plants in the industry, pollution results from practices that allow materials to come in contact with the water. Pollutant levels at these plants can be greatly reduced or eliminated by suitable in-plant control measures that prevent wastes from entering the water or by more extensive reuse and recycling of water that may become contaminated.

For the plants in the leaching subcategory, wastes are necessarily introduced into the water and recycling is not feasible. Thus, for these plants, treatment is required to reduce the pollutant loading. Only a limited improvement can be expected from the application of available control technology. The main control and treatment methods for the cement industry involve recycle and reuse of waste water. The devices employed include cooling towers or ponds, settling ponds, containment ponds, and clarifiers. Cooling towers or ponds are used to reduce the temperature of waters used to cool process equipment. Settling ponds are used primarily to reduce the concentration of suspended solids. Containment ponds are used to dispose of waste kiln dust. Clarifiers are mainly used to separate solids in dust-leaching operations.

With the exception of plants in the dust-contact subcategory, both wet-process and dry-process plants can achieve virtually complete reuse of waste water with existing state-of-the-art technology.

With respect to waste water management, wet-process cement plants have features that distinguish them from dry-process cement plants. In all wet-process plants, except for those that leach collected dust, the waste waters from sub-processes (e.g. plant clean-up, truck washing, and cooling) and storm runoff waters, can be used in the raw mills to prepare the slurry fed to the kiln. In the kiln the water is evaporated, any inorganic matter in the water enters the product, and any organic matter in the water is burned. Thus, for wet-process plants complete reuse of waste waters is possible, although in some existing plants installation of cooling towers or ponds may be necessary to permit recycling of excess cooling water.

In contrast to the practices possible in wet-process plants, for dry-process plants disposal of waste waters from sub-processes in the kiln is not possible. Nevertheless, a number of dry-process plants have achieved virtually complete recycle of waste waters by the employment of cooling towers or ponds. The only discharge from these plants is the small volume of "blow-down" or "bleed" water from cooling towers that is required to prevent buildup of dissolved solids in the cooling water,

and where contaminated, these small volumes can be evaporated at low cost.

Even without recycling, control measures can be taken to prevent introduction of contaminants into the water effluent from the plant. Cooling water streams can be segregated from other streams, and precautions can be taken to avoid entry of dust into the cooling water circuit.

#### In-Plant Control Measures

In-plant measures are primarily limited to the control of noncontact streams. For plants within the leaching subcategory, control technology consists of segregation of the leaching streams from other plant discharge streams and conservation of water to minimize the volume of water requiring treatment.

Control technology applicable to noncontact streams is discussed below for the major water uses and potential sources of waste water. The individual plants referred to are discussed in detail at the end of this section.

#### Cooling Water

In either wet-or dry process cement plants, water is used to cool process equipment such as bearings, compressors, burner tubes, and cement coolers by non-contact heat exchange. The waste waters from these cooling operations are hotter than the entering water. The temperature rise in waters used to cool bearings is normally small, and desirably low temperatures can often be achieved by a simple recycle system in which heat is lost to the atmosphere from a small amount of pipe or a package recycle system as is the practice at Plant A. In waters used to cool compressors, burner tubes, or cement coolers, the temperature rise is larger. However, if the temperature of cooling waste water is reduced, the waters may be recycled. Temperature reduction has been accomplished in cooling towers (plants B and E) and in spray ponds (plant F), or by simply recycling to a storage pond of sufficient area so that surface evaporation maintains a stable temperature.

The suspended solids concentration in recycled waters used in cement coolers can increase because the cooling stream in many cement coolers is open to a dust-laden atmosphere. If a cooling pond is used to cool the water before recycling, the pond can also serve as a settling pond. However, if cooling towers are used, a small-volume "bleed" or "blow-down" stream from the recycle stream is normally provided to maintain suspended and precipitable dissolved solids at a low concentration.

At a few plants, waste cooling waters from bearings or compressors may contain lubricants. Such cooling waters can be segregated to prevent dilution and treated to remove lubricants if necessary. Flotation and

skimming usually suffice for removal of lubricants, but emulsion breaking may be needed in extreme cases.

#### Process Water

Process water as defined in this report refers only to the slurry water used in wet plants. Since this water is evaporated, no direct discharge is associated with it. However, precautions need to be taken to insure that overflow from slurry tanks, leaks from slurry lines, and tank clean-up is prevented from entering the discharge from the plant or is adequately treated before discharge. As discussed above, at many wet-process plants the slurry mix itself can represent a convenient control measure for handling at least some waste water generated in the plant. Unless these waste waters are highly alkaline, they can be used to prepare the slurry, as is done at plants A, B, and C; the water is evaporated in the kiln, and the wastes that would otherwise have to be treated or eliminated by other control measures are consumed in the product.

#### Kiln Dust Piles Runoff Water

For plants collecting a high-alkali dust not returnable to the process, surface dumping on the plant site or in an adjacent quarry is most common. Disposed of in this way, the dust could affect the quality of the plant effluent through runoff or quarry dewatering. Therefore, adequate precautions must be taken to enclose the dust disposal area with dikes to contain runoff or to use areas of the quarry not subject to flooding by ground water.

Another technique for disposal of dust is mixing it with water to make a slurry that is pumped into a lagoon. In some cases the overflow from the lagoon is discharged. However, in the past few years, at least three plants that slurry their discarded dust have eliminated the overflow from the lagoons by recycling this water for slurry disposal. Plant H illustrates this practice.

#### Housekeeping

Contaminants, primarily in the form of suspended solids, can enter waste waters in other ways; such as, in-plant clean-up and truck washing, and by pick-up of dust by storm runoff waters. The amounts of solids introduced into waste waters by plant cleanup can be minimized by good maintenance and operating procedures to minimize solid spillage and to return dry dust to the process, and the solids introduced into storm runoff waters can be minimized by paving areas for vehicular traffic, by providing good ground cover (e.g. grass) in other open areas, and by removing accumulations of dust from roofs and buildings for return to the process. Implementation of more stringent air pollution controls is expected to result in a significant reduction in suspended solids in runoff waters.

If introduction of solids into waste waters cannot be prevented, settling ponds can be provided for the waste waters that are affected by



suspended solids build-ups (e.g. the waters from floor-drainage sumps, waters from raw-mill cleaning and slurry-pump leakage in wet-process plants, and storm water runoff).

### Treatment Technology

With the exception of settling ponds for the removal of suspended solids, treatment of waste water in the cement industry is practiced primarily at leaching plants.

#### Leachate Water

As mentioned in Section VI, pH, alkalinity, suspended solids, and total dissolved solids (principally potassium and sulfate) are pollutants present in the effluent from leaching plants. The treatment technology currently practiced can adequately control pH, alkalinity, and suspended solids, but not dissolved solids.

Neutralization by the addition of mineral acids such as sulfuric acid has the following effects: it lowers the pH to any desired level; it eliminates alkalinity by neutralization of hydroxyl, carbonate, and bicarbonate ions if it is followed by aeration to remove carbon dioxide; and it dissolves acid-soluble particulate matter such as lime that is present as suspended solids in the leachate overflow. However, it adds to the total dissolved solids content because the sulfate ions are heavier than any of the ions that are removed by neutralization.

Carbonation lowers the pH by replacing hydroxyl ions with carbonate ions. Additional carbonation converts carbonate ions to bicarbonate ions. Total alkalinity is not reduced by carbonation, because the carbon dioxide escapes when the bicarbonate solution is acidified or aerated. However, carbonation can be used to reduce in hardness of the leachate. The solubility of calcium reaches a minimum value of 16 ppm (at 16°C) when the pH has been lowered to 9.5 by carbonation, as shown in Figure 10 (39). Any subsequent addition of carbon dioxide to lower the pH raises the solubility of calcium because calcium bicarbonate has nearly the same solubility as calcium oxide.

The above discussion suggests that carbonation might be advantageous as a treatment for leachate. Overflow from the primary clarifier could be carbonated with stack gas to lower the pH to 9.0, near the pH required for minimum solubility and an acceptable pH for discharge. This would cause precipitation of calcium carbonate which could be removed in a secondary clarifier or settling pond.

Carbonation may reduce the dissolved solids by converting dissolved calcium oxide to less soluble calcium carbonate which appears as fine suspended solids that must be removed by settling. Suspended solids may be controlled to less than 50 mg/l as is done in Plant I by proper design and operation of the clarifiers.

The degree of clarification is determined by several factors including the length of time the leachate remains in the clarifier, the turbulence

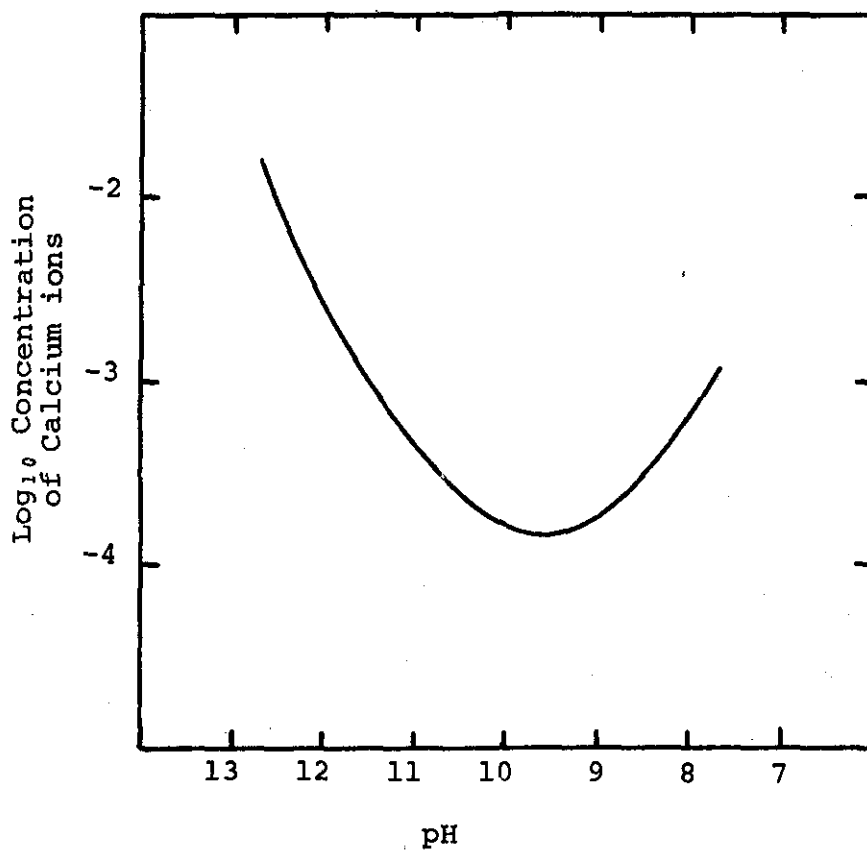

Figure 10. Solubility of Calcium Carbonate as a Function of pH.

in the clarifier, and the characteristics of the dust. The residence time and the degree of turbulence in the clarifier are fixed design parameters. However, the characteristics of the dust can be controlled to some extent.

One way of controlling the dust characteristics is by selecting what dust is to be leached. Maximum flexibility of selection is achieved when electrostatic precipitators are used to collect the dust from the kiln exhaust gases. In electrostatic precipitators the larger particles are more easily removed from the gas stream, so they are recovered in the first stages of the precipitator. The smallest particles are collected in the last stage. Precipitators are designed so that these fractions of dust are segregated in several hoppers. The fine particles in the last hopper have significantly higher alkali content than the coarse particles in the first hopper. By leaching only the dust from the last hopper, the load of the leaching system can be significantly reduced. However, in Plant I all the collected dust is leached because the coarse particles make the slurry easier to handle.

The settling characteristics of the dust can also be controlled by the addition of flocculating agents to the water used for leaching the dust.

Although none of the leaching plants use a treatment process to remove dissolved solids from the leachate effluent, there are methods and technologies that are potentially applicable. Several processes that might be employed include evaporation, precipitation, ion exchange, reverse osmosis, electrodialysis, and combinations of these. Each process must be considered in relation to the problem of disposal of the removed salts. Some of these processes have technical limitations associated with their use in this application. For example, in ion exchange large amounts of acid and base are required to regenerate the resins. The amount of waste material would be approximately twice as great as for other separation processes. Similarly, although reverse osmosis is useful for desalination of dilute solutions, the dissolved solids content of the leachate is too high for this process to be practical.

Evaporation of the leachate could potentially eliminate the effluent. Although solar evaporation would have low operating cost, it could be used only in arid climates and where a large amount of land is available for evaporation ponds. Evaporation by submerged combustion or heat exchangers involves considerable cost for fuel and equipment. Waste heat from the kiln might be employed for evaporation of leachate, however, the economic feasibility of this practice is uncertain in the absence of industry experience. Reduction of the quantity of water to be evaporated by concentrating the leachate in some other process may be desirable.

A technology that appears promising for concentration of leachate is electrodialysis (ED), which has been successfully applied to the concentration of sea water for the recovery of salt. (30) If ED were used, the concentrated stream would be more easily evaporated and the concentration of salts in the dilute stream would be low enough to allow

it to be recycled to the leaching system. ED could be transferred directly to the concentration of leachate with two variations.

First, calcium ions must be removed to prevent precipitation and fouling of membranes. Reducing the pH to 9.5 by carbonation with stack gas will reduce the concentration of calcium ions to a minimum as was discussed above.

Second, reduction of the concentration of salts to a point where the water could be recycled in the leaching process will raise the cell resistance. Thus, more power must be provided than is needed for recovery of salt from sea water. A third desirable feature is additional carbonation to reduce the pH of the clarified leachate from 9.5 to about 8.0.

A flow diagram of a conceptual design for electro-dialytic concentration of leachate is shown in Figure 11. At a typical leaching plant, about 6.5 kg/kg (13 lb/ton) of dissolved solids are generated in the leachate stream, of which potassium salts are a major component. If the typical daily production of clinker is 1600 metric tons (1750 tons), the plant will generate about 10 metric tons (11 tons) of salts per day or about 3300 metric tons (3650 tons) per year. The costs of operating such a facility would amount to about \$350/day.

A detailed description of electro-dialytic concentration of electrolytes is given by Nishiwaki in Chapter 6 in Reference 30. Conventional electro-dialytic equipment may be used. The only major change from the practices used in electro-dialysis for desalination is that the concentrating compartments are not fed any water; the water that overflows the concentrating compartments and is withdrawn as brine is transferred through the membranes by electro-osmosis and osmosis.

A diagram of a electro-dialytic stack for concentrating electrolytes is shown in Figure 11A. The stack consists of many (up to 2000) cation and anion-exchange membranes arranged alternately to form solution compartments, as indicated, between a cathode and an anode. The solution to be concentrated is circulated through alternate compartments, as shown. The other set of compartments are closed at the bottoms. No solution is fed to them but they are filled with solution. When electrical current flows through the stack, cations and anions transfer from the circulating solution through the ion-exchange membranes into the closed compartments. Simultaneously, water transfers from the circulating solution through the membranes as a result of electro-osmosis and osmosis. The water, so transferred, overflows from the tops of the closed compartments along with the transferred ions and is withdrawn as concentrated brine. It should be re-emphasized that although only a few membranes and solution compartments are shown in Figure 11A, commercial stacks may have as many as 2000 membranes and 1000 solution compartments.

The usual mode of operation for electro-dialytic concentration stacks is known as feed-and-bleed operation. In this mode of operation only a small portion of the circulating solution is "bled" from a recycle line

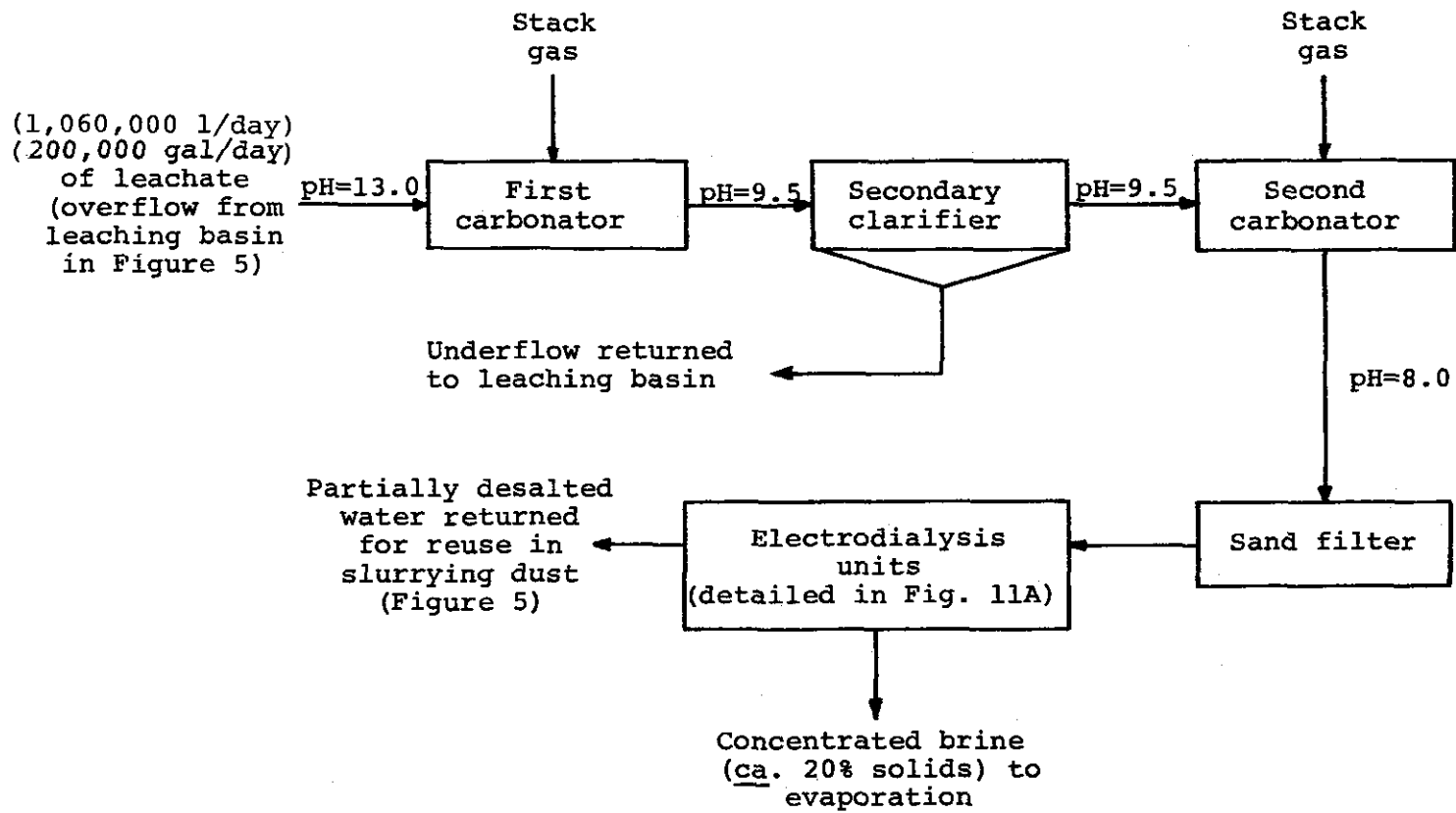

Figure 11. Flow Diagram Showing Steps in Electrolytic Concentration of Leachate

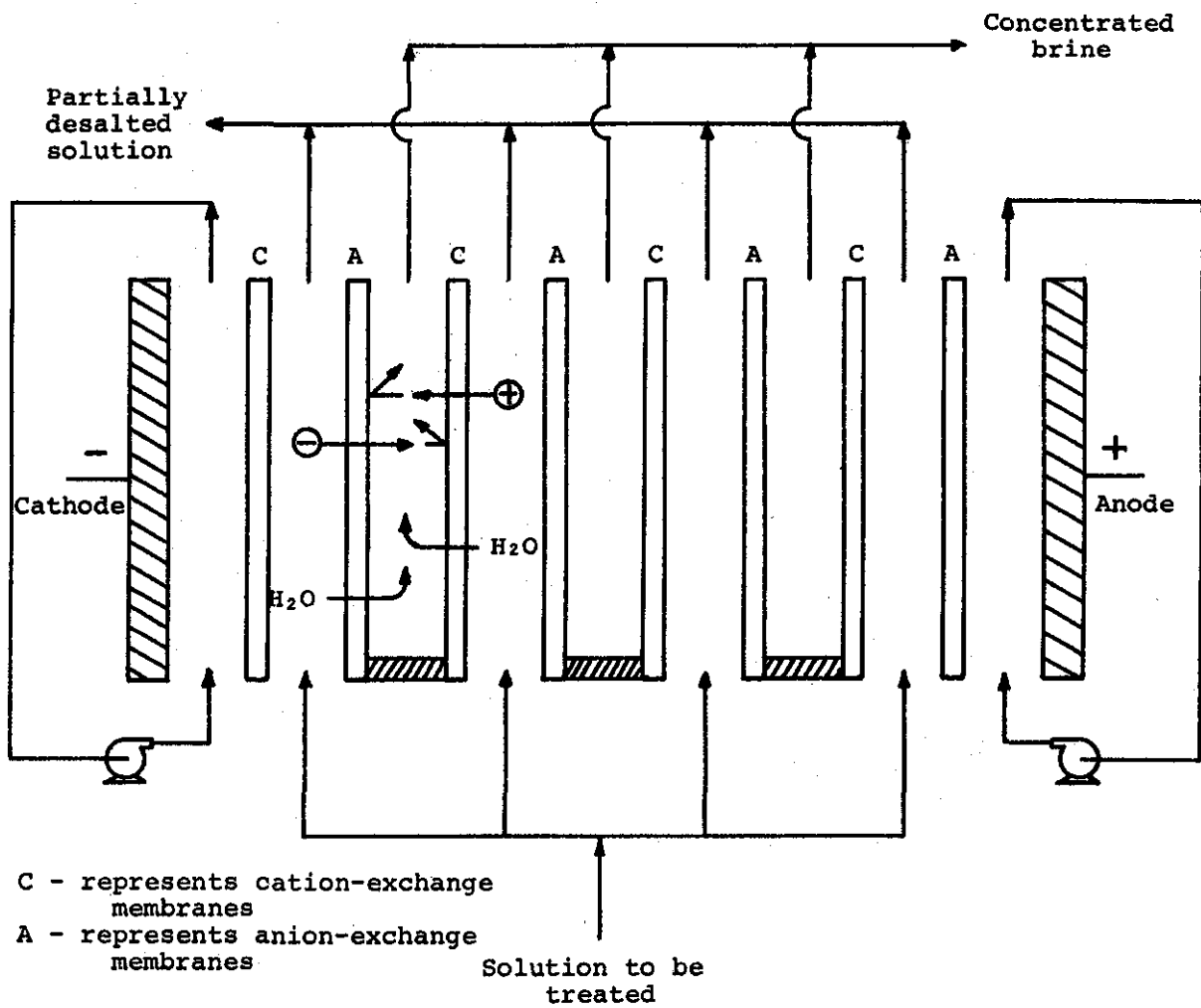

Figure 11A. Diagram of Electrodialytic Concentration Stack

and returned to the cement process for reuse in slurring dust. Most (perhaps 80%) of the solution is mixed with a volume of fresh leachate equal to the amount "bled" from the system and recycled to the "feed" side of the electrodialysis stacks. With this "feed-and-bleed" mode of operation it is possible to transfer ions through the membranes at a high rate, without decreasing the concentration of ions in the circulating solution appreciably in any one passage through the stack. It is desirable to maintain a relatively concentrated circulating solution because with very dilute solutions the resistance of the stack would be high. Therefore the energy requirements, which depend on resistance, would be high.

In the conceptual design, shown in Figure 11, leachate from the primary clarifier would be carbonated with stack gas in two turbo-agitated tanks arranged in series to reduce the pH to 9.5 so that  $\text{CaCO}_3$  will precipitate. The liquid will be pumped to a secondary clarifier in which  $\text{CaCO}_3$  can deposit on existing  $\text{CaCO}_3$  particles carried within the clarifier as inventory. The underflow from this clarifier would be pumped back to the primary classifier; the overflow would be transferred to two secondary carbonators of the same type as the primary ones.

In the secondary carbonators the pH is reduced to 8.0 to convert the  $\text{CaCO}_3$  remaining in solution to  $\text{Ca}(\text{HCO}_3)_2$ . This step is expected to prevent precipitation of calcium ions as the carbonate, since calcium bicarbonate is more soluble than calcium carbonate. As an added precaution against precipitation of calcium as either the bicarbonate or the sulfate, univalent selective cation-exchange membranes should be used. (Such uni-valent selective membranes are described and discussed by Nishiwaki in Reference 30.)

No pretreatment of the feed other than that described above, and filtration, is expected to be needed. Iron and manganese, which have caused troubles with ED units for desalination, should not be present in this feed because any iron or manganese present in the dust should be fully oxidized, and should not leach from the dust at the high values of pH in the leaching section. If silica leaches from the dust, it could present a problem with silica slimes building up on the membranes. The extent to which silica might be leached is not clearly evident.

The solution from the secondary carbonators would be pumped through sand filters and into the ED stacks. As discussed previously, the ED stacks would be operated by a feed-and-bleed method. The partially desalted solution bled from the feed-and-bleed system would be returned to the primary clarifier for reuse in slurring dust. The concentrated brine that overflows from the closed compartments of the stacks would be sent to an evaporation step. The evaporation could be performed in a solar pond in arid climates, or by other means in non-arid climates. Since only about 10,000 gal/day of concentrate must be evaporated, the cost should be low.

Costs for a typical operation, based on this conceptual design, have been estimated and are presented in Section VIII.

The most valuable and most abundant cation in the leachate is potassium, which if suitably recovered might be profitably marketed. The agricultural grade of potassium sulfate has a market price of \$77 per metric ton of potassium oxide (38). Recovery of potassium from cement dust was practiced during World War I to free the U.S. of a monopoly exercised by the German Industry. One cement plant reportedly recovered 17.5 kg of potassium sulfate for each metric ton (35 lb/ton) of cement produced (15).

In 1959 Patzias (21) made a study of a method for extraction of potassium sulfate from cement dust. By leaching at high temperatures in a pressurized vessel he achieved 84% recovery of alkalies from the dust. After filtration the leachate was concentrated by evaporation, neutralized with sulfuric acid, and evaporated to dryness. For a plant treating 180 metric tons/day of dust containing 1.66% of potassium sulfate the calculated capitalized payout for the process was 0.44 years, and the calculated net profit was \$101,304. There would be no discharge from this process because all of the water from the leachate is evaporated. While a process based on this concept appears technically sound, it apparently has not been exploited by the industry. The economic feasibility re-evaluated in view of present costs indicates a recovery cost of about twice the present market price. A flow sheet illustrating this concept is shown in Figure 12.

#### Materials Storage Piles Runoff Control Technology

The runoff from these materials storage piles should be segregated from other plant runoff such as roof drains. The intent is to provide either retention of the runoff from such piled materials or to neutralize and reduce suspended solids before the runoff is discharged to a navigable water.

Retention of runoff may be achieved by dikes, ditches or other means to divert and direct runoff into a retention pond that will serve to remove easily settleable and a portion of the suspended solids and will provide relatively uniform flow to the neutralization process (55). The pH of the effluent from the retention pond will be controlled by addition of appropriate neutralizing agents (e.g. sulfuric acid for runoff from kiln dust piles and lime for runoff from coal piles) to the waste water. For BPCTCA and BATEA the runoff, if discharged to navigable waters, should be neutralized as necessary to achieve a pH between the value 6.0 to 9.0 and treated by lagooning or retention to remove readily settleable solids and reduce suspended solids to 50 mg/l or less. The facilities for neutralization and suspended solids reduction should be designed and constructed to treat the volume of runoff associated with a 10 year, 24 hour rainfall event.

#### Description of Plants that Demonstrate Control and Treatment Technologies

About 30 identified plants in the industry are able to achieve essentially no discharge of pollutants by application of the control and treatment technologies discussed above. Eight of these plants are



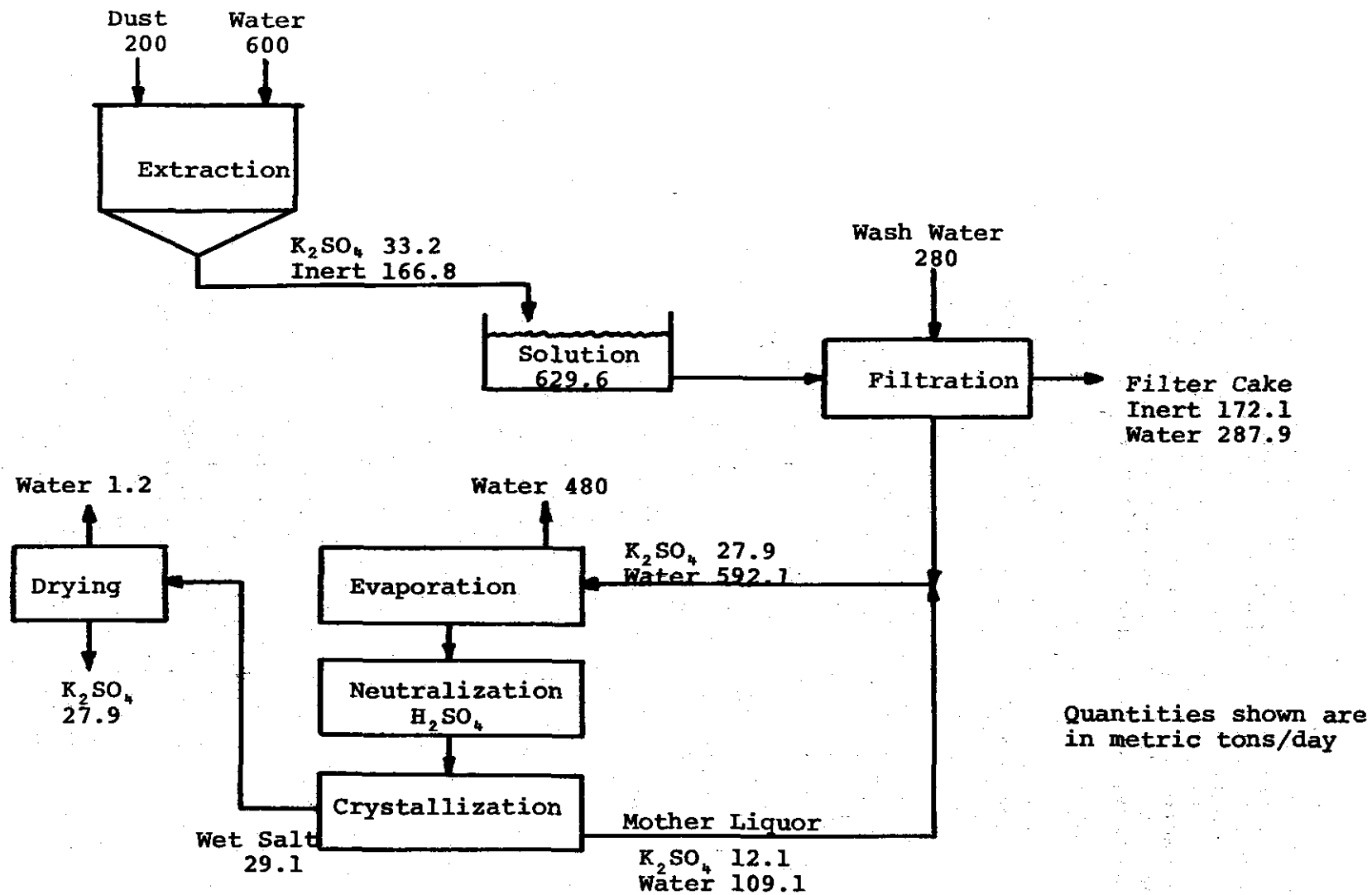

Figure 12. Flow Sheet for the Recovery of  $K_2SO_4$  from Cement Kiln Dust.

discussed below to illustrate variations in particular methods used to minimize discharge of pollutants. While no plants in the leaching sub-category have achieved this level of performance, an example of a leaching plant and a plant with a wet scrubber are included to illustrate features of existing control and treatment technology which, if implemented in proper combination, would result in minimum discharge of pollutants. The information was obtained through on-site studies, questionnaires, and telephone interviews.

#### Plant A - Complete reuse of all water, including runoff

This wet-process plant built in 1939 has electrostatic precipitators on four kilns and bag houses on two kilns. All dust collected (about 10% of the kiln feed) is returned to the kilns without treatment since the raw materials used are low in alkali content. The overall water management plan for Plant A is shown in the simplified diagram in Figure 13. The bearing-cooling water systems in this plant are closed recycle systems. A small amount (less than 1%) of the recycling stream is bled off and sent to the dump. An equal amount of fresh make-up water is added. In the cement cooler the finished product is conveyed vertically through a large cyclinder by a screw mechanism. Heat is removed by water flowing through a jacket on the outside of the large cylinder. The temperature of the heated water is reduced in a cooling tower. Fresh water is added to the recycling stream to replenish the evaporative losses in the cooling tower. The tower blow-down (less than 1% of the recycle stream) goes to the sump.

The water needed for cooling-water make-up, raw-material beneficiation, and slurry preparation comes from an elevated pond as shown in Figure 13. The pond is fed by water pumped from the quarry and by water purchased from a municipal water system. Water flows from the pond to the raw-materials beneficiation plant. Water accompanies the slurry that is dredged from the pond and sent to a thickener. The overflow from the thickener is pumped back to the pond, and the underflow is pumped to one of two raw mills. Solids from the first raw mill are fed to the second raw mill (along with some water). The slurry from the second raw mill is kiln fed.

All waters from plant clean-up and truck washing drain into a sump. storm runoff waters are intercepted by a series of ditches and led to the sump. The sump also receives blow-down water from the cooling systems and drainage from a sand pile (the company sells construction sand from raw-materials beneficiation). The sump is provided with a level controller. Water is pumped back to the elevated pond on a intermittent basis, controlled by a level controller. The pumps and level controller are provided with alarm systems to notify plant personnel in case of pump failure, because the sump could overflow into an adjacent stream if the pumps failed during heavy rainfall.

#### Plant B - Complete recycle and reuse of water

This plant uses oyster shells as raw material. Wastewater treatment facilities installed in 1973 consist of a system of settling ponds to

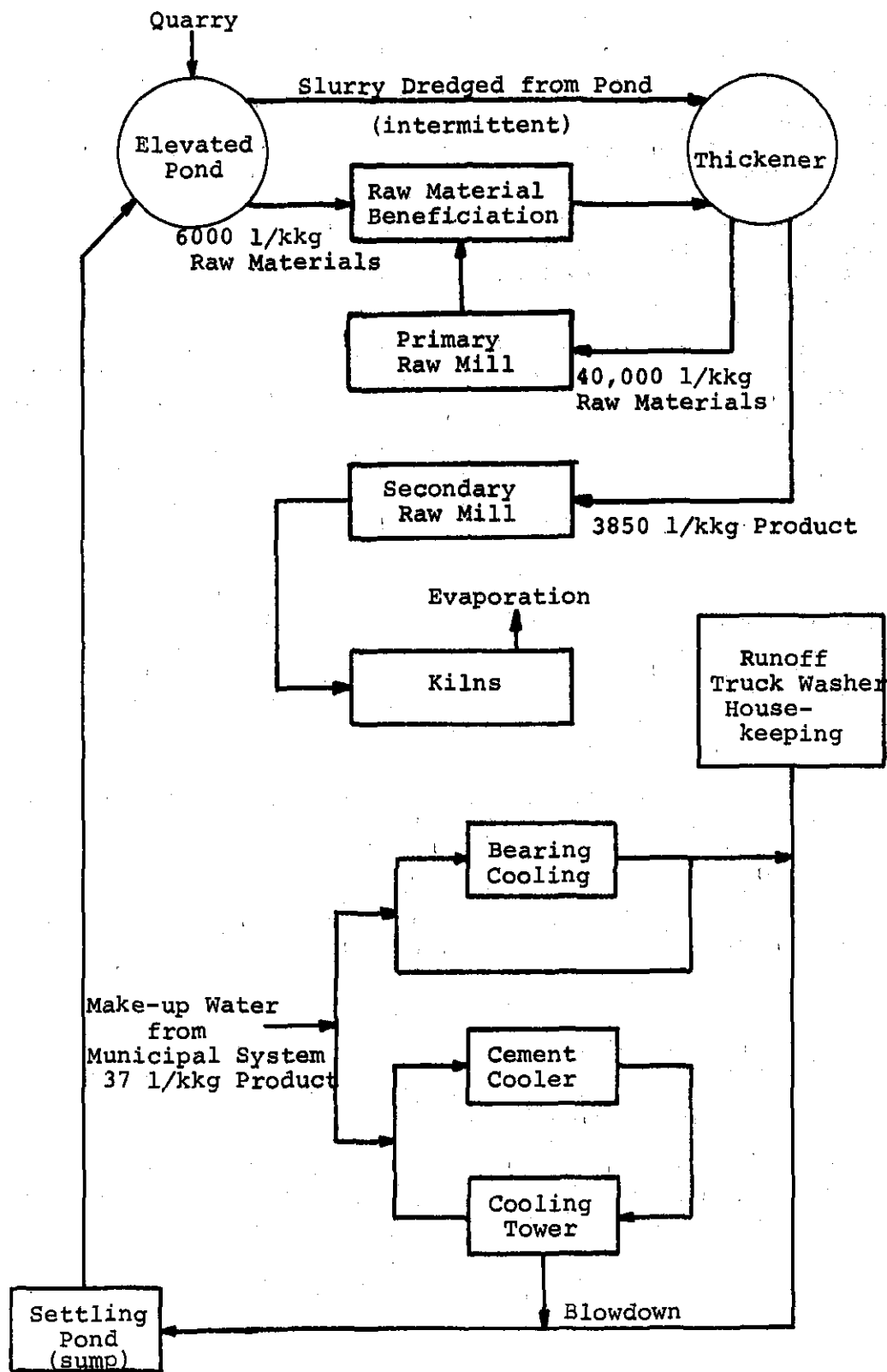

Figure 13. Diagram of Water-Management Plan for Plant A

clarify waste water from a clay-washing operation and to recover settled solids for use in the process. Electrostatic precipitators are used to collect kiln dust (about 6% of the kiln feed is collected as dust). No dust is returned to the kilns. Some of the dust is used along with a stabilized shell mixture for fill dirt on road projects in the area. The rest of the dust is returned to an unused area of the clay pits.

In Plant B water is obtained from a deep well and is first used for cooling, as shown in Figure 14. The water for the cement cooler is recycled through a cooling tower and water is added from the well to replenish losses.

Some of the waste water from the bearing-cooling circuits is used to spray the belt used to transfer oyster shells from the unloading station at the dock to the raw mills to prevent the shells from sticking to the belt. This water is subsequently used for slurry preparation. Other waste water from the bearing cooling system is used for raw-material beneficiation and subsequently used for slurry preparation. Still other bearing cooling water is used to cool cement clinker by direct contact and is evaporated. No waste water is discharged from this plant.

#### Plant C - Complete reuse of water

This wet-process plant, built in the twenties is situated adjacent to a creek. Two smaller creeks on the plant site are fed principally by runoff, and originally drained into a larger creek. The flow from these two creeks has been diverted to a sump to provide a source of water for the plant. The larger creek is connected to the sump through a spillway, as shown in Figure 15.

All process water for cooling, plant clean-up, slurry preparation, and other uses is pumped from the sump to an elevated tank. In normal operation the plant uses more water for slurry preparation than is normally available from the two small creeks. Since the water used for slurry preparation is evaporated in the kilns there is a net inflow of water from the larger creek through the spillway into the sump. Thus, no water is discharged from this plant, except during periods of heavy rainfall, when the level of the water in the sump is higher than that of the larger creek.

All cooling water is discharged through two outfalls into the two small creeks. All waters used in plant clean-up and truck washing and water that has seeped into the quarry, which is on the plant property, is also discharged into one of the creeks.

All of the dust is collected by cyclones at this plant (about 6% of the kiln feed is collected as dust) and is disposed of by surface piling within the plant area. Any runoff of water from the dust piles drains into the sump.

#### Plant D - Once-through cooling water isolated from contamination

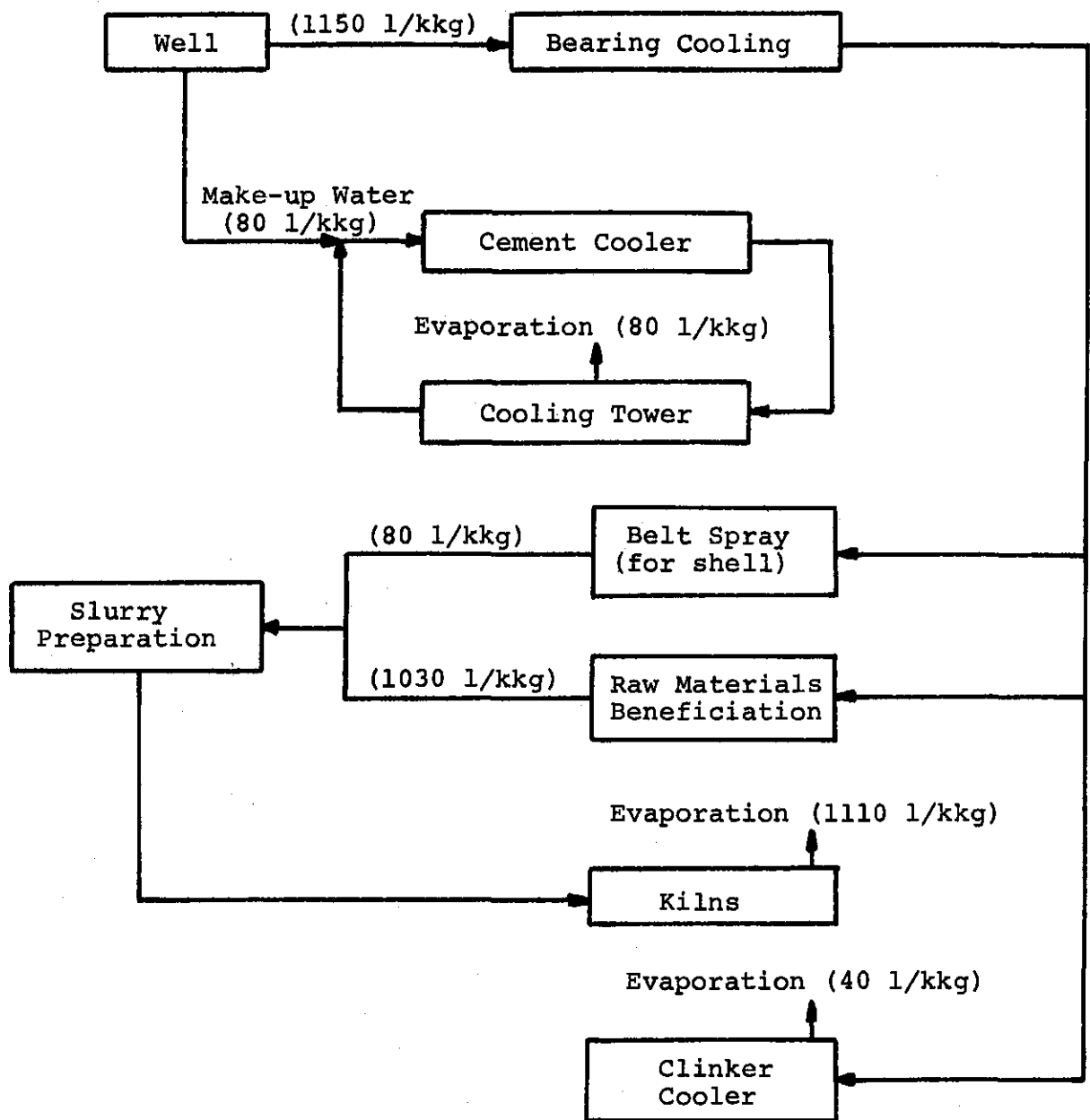

Figure 14. Diagram of Water-Management Plan for Plant B

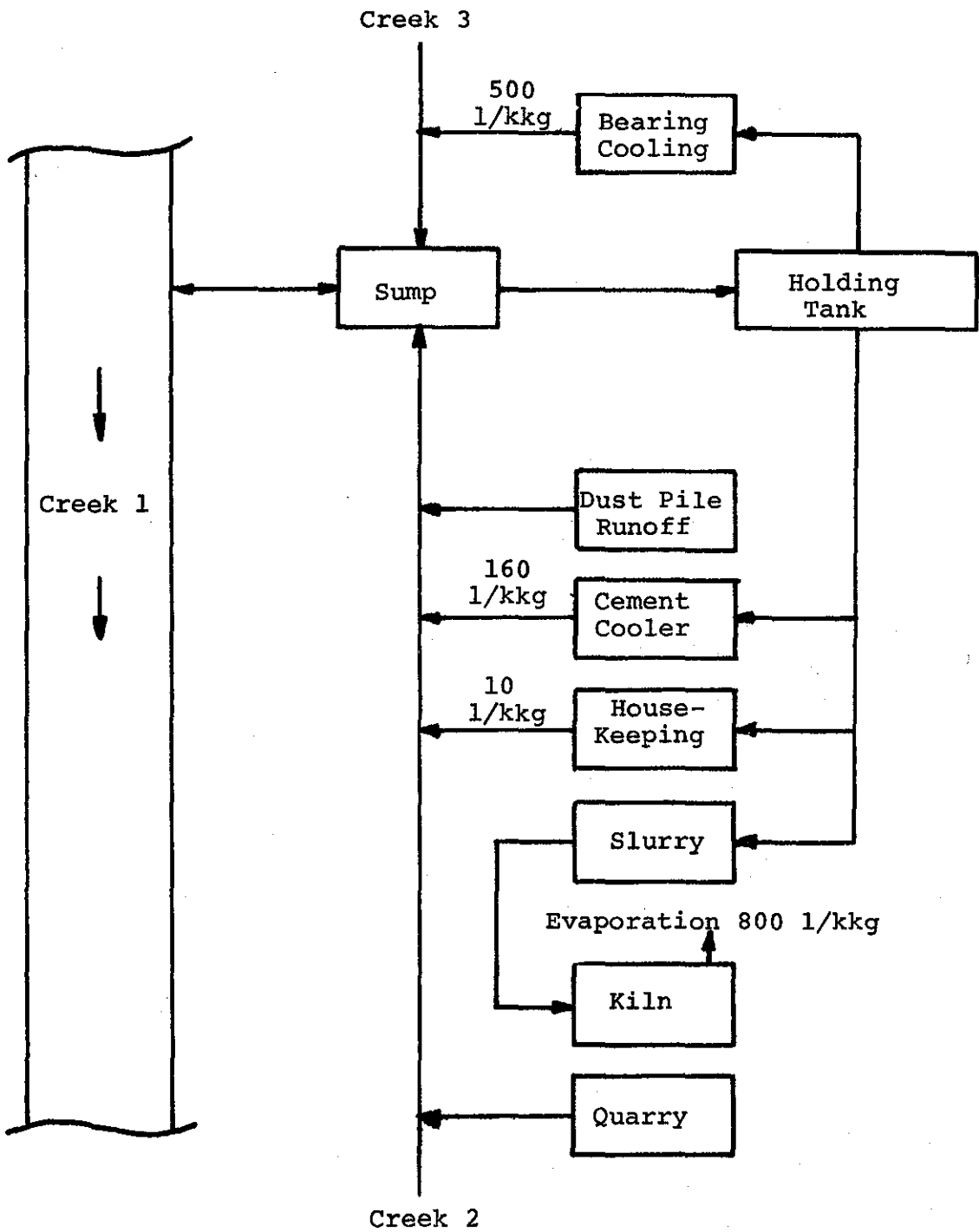

Figure 15. Water-Management Plan for Plant C.

As indicated in Figure 16, there are two sources of water for this plant: a river, and a shallow well. River water is pumped through a loop of pipe that traverses the area in which the mills and kilns are located. About 1090 l/kg (270 gal/ton) is withdrawn from the pipe loop and used in the process. About 23,000 l/kg (5500 gal/ton) is withdrawn for use as cooling water for bearings and compressors. This cooling water re-enters the pipe loop and is discharged to the river along with some excess water in the loop that is not used, except for cooling the waste water from bearing cooling by dilution. About 230 l/kg (55 gal/ton) is also withdrawn from the pipe loop to cool clinker. This water evaporates. About 375 l/kg (90 gal/ton) of water is pumped from a shallow well to the cement cooler. The warm waste water from the cooling operation is discharged to the river.

#### Plant E - Recycling of all cooling water with cooling tower

This is a dry-process plant, built in the 1950's. The dust from the kilns is collected in bag houses. Almost all dust collected (about 5% of the kiln feed is collected as dust) is returned to the kilns. Only a small amount (0.015 metric tons per metric ton of product) is wasted by returning it to the quarry.

With the exception of small amounts of water used for cleaning (e.g. plant and truck clean-up) all water used is for non-contact cooling. The waste water from all cooling operations, typically 625 to 730 l/kg (150 to 175 gal/ton) of product, is recycled through two cooling towers. The blow down from the towers (about 12 l/kg of product) is discharged. This amount of water could easily be evaporated at low cost. The water required to replenish the blow-down and evaporative losses in the cooling towers amounts to about 83 l/kg (20 gal/ton) of product, which is obtained from a deep well.

#### Plant F - Recycling of all cooling water with spray pond

This is a dry-process plant built before 1900. The latest modification that affected water management practices was the installation in 1965 of a reservoir with spray cooling and a recycling system for cooling water. About 0.1 metric tons of dust per metric ton of product is collected in a multicyclone collection system and is returned to the kiln.

Water requirements for bearing cooling and the cement cooler are about 2300 l/kg (550 gal/ton) of product. All cooling water is recycled to the spray-cooled reservoir. In the reservoir about 230 l/kg (55 gal/ton) of product is evaporated. This plant also uses water to cool cement clinker in a direct-contact process. This water, 83 l/kg (20 gal/ton) of product, is evaporated. Water is supplied to the reservoir at a rate of about 300 l/kg (72 gal/ton) of product to replenish the evaporative losses.

#### Plant G - Once through cooling water with settling pond

This is a dry-process plant about 35 years old. The plant withdraws about 3000 l/kg (730 gal/ton) of water from a river as shown in Figure

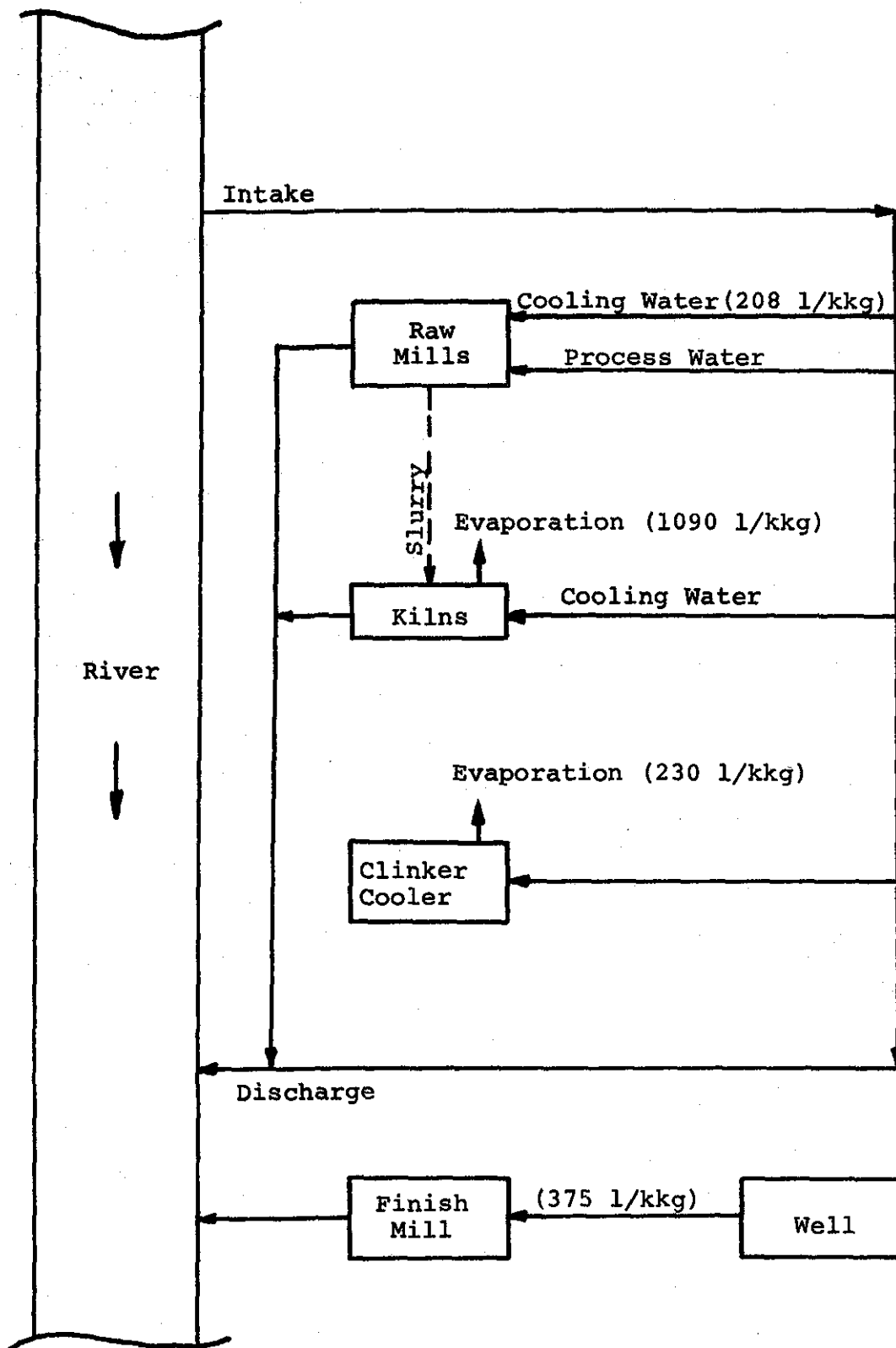

Figure 16. Diagram of Water-Management Plan for Plant D



17. This water is treated by flocculation and settling and about 170 l/kg (40 gal/ton) of backwash water from the water-treatment plant drains to a settling pond. Approximately 2870 l/kg (690 gal/ton) of the treated water is used as cooling water. A portion of the cooling water, about 375 l/kg (92 gal/ton) of product is evaporated in cooling kiln gases and cement clinker. All other water drains into a settling pond. Water overflows a spillway at the low end of the settling pond into a small creek that leads back to the river.

#### Plant H - Recycling of waste-dust-slurry water with stack gas neutralization

This is a wet-process plant about 10 years old. Dust from the kiln is collected in an electrostatic precipitator.

In 1964 a dust-leaching system was installed in the hope that the dust could be returned to the kiln. However, the system could not be made to work acceptably. Some of the components of the system were then used to develop a system for disposal of the dust. This system appears to be adaptable for use at other plants and is, therefore, described below.

As shown in Figure 18, dust from the precipitator hopper is transferred to an agitated tank, where it is mixed with water. A slurry is pumped from this tank through four gas absorbers in series. A small amount of the gas from the stack is sparged through the slurry in the gas absorbers to reduce the pH from about 12 to about 8 by absorption of carbon dioxide. The slurry is pumped from the last gas absorber to a system of two lagoons. The distance to the lagoons is about 460 meters (1500 feet), and much of the distance is traversed by fire hose. The fire hose is used because precipitates tend to deposit inside the hose, and periodically the hose is collapsed by walking or beating on the outside of it to break-up and flush out the deposits.

Both the dust and precipitates formed by carbonation with kiln gas settle in one of the lagoons. The water drains into a sump in the lagoon that is provided with a floating suction-head and a pump. The clear water is pumped back to the dust-treatment tank for reuse in slurring more dust. Some water is lost from the lagoon. Since the lagoon was made with an impermeable clay bottom, presumably most of the water is lost by evaporation. The make-up water supplied to replenish losses averages about 1300 l/kg (315 gal/ton) of dust, or about 83 l/kg (20 gal/ton).

Each of the two lagoons is about 2.43 ha (6 acres) in area. Two lagoons are provided so that one could be used to receive slurry, while the other was excavated for sub-base fill for use in road and parking lot construction. The plant sells the sub-base fill to a construction company. By the time one lagoon is filled with solids, the second has been excavated so it can be used to receive slurry.

#### Plant I - Sedimentation for removal of suspended solids from leachate stream

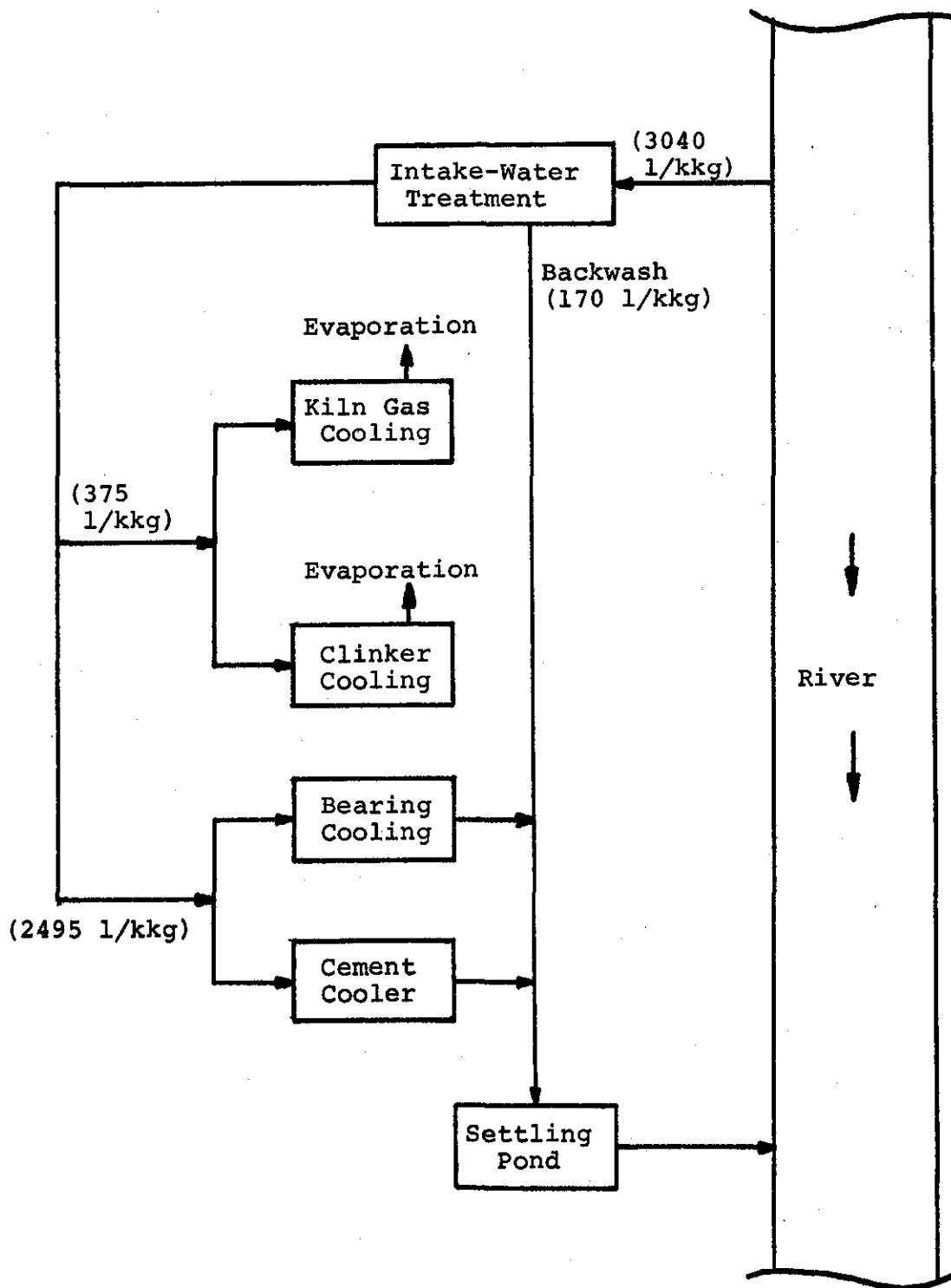

Figure 17. Diagram of Water-Management Plan for Plant G

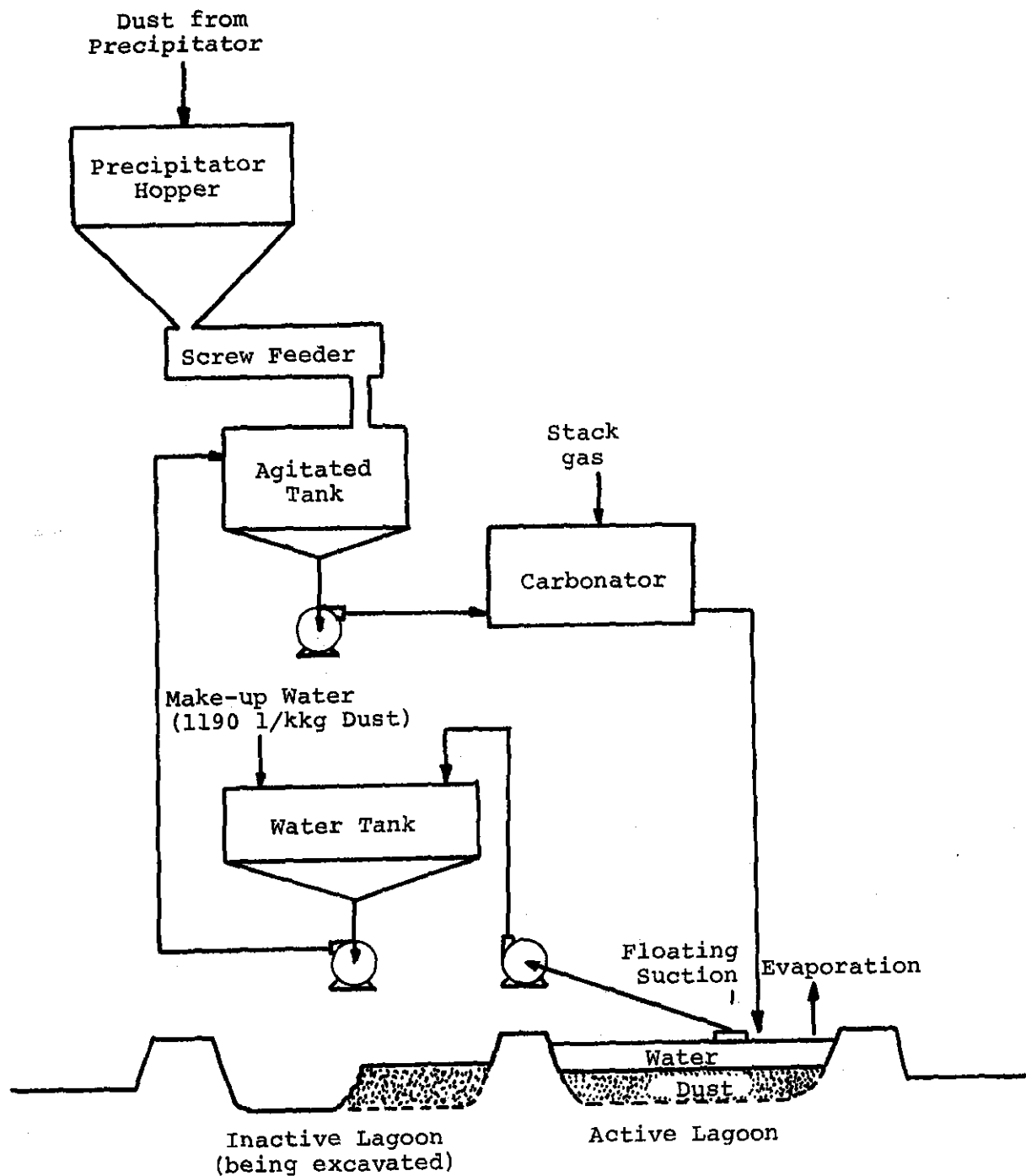

Figure 18. Diagram of Dust-Handling System at Plant H

This plant uses cyclones followed by electrostatic precipitators to collect kiln dust. If all of the collected dust were returned directly to the kilns, the alkali content of the product would be 0.8 to 0.9%, well above the 0.6% maximum for low-alkali cement. By leaching the alkalis from the dust before it is returned to the kiln, the alkali content of the product can be maintained in the 0.5 to 0.7% range. It is the practice at this plant to leach half of the collected dust and return it to the kiln. "The other half of the dust is returned to the kiln without leaching."

The plant has two kilns and two separate dust collection and leaching systems. Dust collected in the cyclones and precipitators of each kiln is conveyed to a pug mill where well water is mixed with the dust to make a slurry containing 10% solids. The soluble alkalis, usually about one third to one half the alkali content, dissolve quickly. The slurry enters the center of the clarifier and is distributed by a revolving bar. The leached dust particles settle to the bottom of the clarifier to form a dense slurry. The rate of removal of material from the bottom of the clarifier is controlled to maintain a solids content of about 45% in the underflow. The underflow is pumped back to the kiln.

The combined overflow from the two clarifiers flows directly to the river. It has a pH of 12.9 and is only slightly turbid (suspended solids content of 40 mg/l). This low value of suspended solids content suggests that the 13.7 m (45 ft) diameter of these clarifiers provides a rise-rate that is adequate. (A similar plant with 8.5 m (28 ft) diameter clarifiers had 660 mg/l suspended solids in the overflow.)

#### Plant J - Treatment of wet scrubber effluent

This plant uses a wet scrubber as its main dust collector for the combined exhaust from three kilns. The effluent from the scrubber is treated with a polyelectrolyte before it flows into a clarifier where the major portion of particulate matter is removed and returned to the raw mills. The retention time in the clarifier is 3.7 hours. Sulfite and sulfate that are adsorbed from the stack gases by water are apparently converted to hydrogen sulfide in the clarifier (perhaps by the clarifier if chlorination is not practiced. Chlorine is added to the leaving the clarifier to oxidize the sulfide ions. Then the water cascades down the side of the quarry into a large pond. After the particulate matter settles the water is recycled from the quarry through the scrubber.

The decision to install the wet scrubber described above was based on the significantly lower cost of a scrubber compared with that of a baghouse or an electrostatic precipitator. This cost advantage was reduced somewhat by subsequent modifications to meet water pollution control standards. Although plagued with many operational problems initially, the scrubber is now operating satisfactorily.



## SECTION VIII

### COST, ENERGY, AND NON-WATER QUALITY ASPECTS

#### Cost and Reduction Benefits of Alternative Control and Treatment Technologies

A detailed analysis of the costs and pollution reduction benefits of alternative control and treatment technologies applicable to both subcategories of this industry is given in this section of the report. Table 12 summarizes the results of the analysis.

##### Nonleaching Plants

The present waste loadings from a typical nonleaching plant are shown in Table 12. These values represent the median of all values greater than 0.005 kg/kg (0.01 lb/ton) of product reported by nonleaching plants.

Alternative A - Recycling and reuse of all water used in manufacturing, and containment or treatment of runoff from kiln dust piles.

This alternative will result in essentially no discharge of pollutants. The investment cost of implementing this technology at a typical plant will be about \$300,000 including a cooling tower (\$94,000) or spray pond (\$91,000), the necessary piping (\$76,000), and diked storage areas and neutralization facilities for coal piles and kiln dust piles (\$132,000). If an evaporative cooling pond is used, the costs would be about \$240,000 including piping, but not the cost of land.

The operating costs of Alternative A will range from about \$20,000 to \$30,000 per year including maintenance, sludge removal, chemicals, labor, cost of power, and taxes and insurance. Power costs are limited to pumping and amount to \$13,000 per year.

##### Alternative B - Limited reuse and in-plant controls

This alternative consists of isolation of cooling streams from possible contamination, reuse of cooling water in feed slurry (wet-process plants), retention and reuse or treatment of miscellaneous waste water (e.g. truck washing) and containment or treatment of runoff from coal piles, and kiln dust piles and would also result in essentially no discharge of pollutants in manufacturing effluents.

Cost of implementing this alternative at individual plants may vary widely but on the average will be comparable to that for Alternative A. About 35 of 154 plants in the nonleaching subcategory (23%) are now achieving essentially no discharge of pollutants under either one of the alternatives described above.

##### Leaching Plants

Table 12 WATER EFFLUENT TREATMENT COST AND POLLUTION REDUCTION BENEFITS

<u>ALTERNATIVE</u> <u>DESCRIPTION OF</u> <u>ALTERNATIVE</u>	<u>NON-LEACHING PLANTS</u>		
	Present State No Added Controls	<u>A</u> Installation of Cooling Tower or Spray Pond and Containment of Dust Pile Runoff	<u>B</u> Isolation of Cooling Streams, limited reuse
INVESTMENT		\$300,000	\$300,000
ANNUAL COSTS			
Capital		\$24,000	\$24,000
Depreciation		\$30,000	\$30,000
Operation and Maintenance		\$30,000	\$20,000
Energy and Power		<u>\$13,000</u>	<u>\$5,000</u>
Total		\$97,000	\$79,000
EFFLUENT QUALITY in kg/kkg of cement except thermal and pH			
Alkalinity	0.12	No	No
Suspended Solids	0.075	Discharge	Discharge
Dissolved Solids	0.19	of	of
Sulfate	0.045	Pollutants	Pollutants
Potassium	0.08		
Maximum pH	11		
Thermal (ΔT) in °C	2-11	3	3

TABLE 12 (Continued)

<u>ALTERNATIVE</u>	<u>LEACHING PLANTS</u>		
		<u>C</u>	<u>D</u>
DESCRIPTION OF ALTERNATIVE	Present State No added Controls	Recycle and Reuse of Cooling and Miscellaneous Water, Neutralization and Settling of Leachate	Same as C plus Electrodialysis of Leachate to reduce TDS and Recycling of Leachate
INVESTMENT		\$425,000	\$645,000
ANNUAL COSTS			
Capital		\$34,000	\$51,000
Depreciation		\$42,500	\$64,500
Operation and Maintenance		\$40,000	\$68,000
Energy and Power		\$13,000	\$41,000
Total		\$129,500	\$224,500
EFFLUENT QUALITY in kg/kg of cement except thermal and pH			
Alkalinity	1.38	1.38	No
Suspended Solids	0.905	0.15(a)	Discharge
Dissolved Solids	6.62	6.62	of
Sulfate	3.66	3.66	Pollutants
Potassium	3.3	3.3	
Maximum pH	12.5	9	
Thermal ( $\Delta T$ ) in °C	2-11	3	3

a. Based on quantity of leached dust.



TABLE 12 (Continued)

<u>ALTERNATIVE</u>	<u>LEACHING PLANTS</u> <u>E</u>
DESCRIPTION OF ALTERNATIVE	Abandonment of Dust Leaching
INVESTMENT	\$205,000
ANNUAL COSTS	
Capital	\$16,400
Depreciation	\$20,500
Operation and Maintenance	\$30,000
Energy and Power	\$13,000
Dust Disposal	\$165,000
Total	\$244,900
EFFLUENT QUALITY in kg/kg of cement except thermal and pH	
Alkalinity	No
Suspended Solids	Discharge
Dissolved Solids	of
Sulfate	Pollutants
Potassium	
Maximum pH	
Thermal ( $\Delta T$ ) in °C	3

The present waste loading from a typical leaching plant is shown in Table 12. These typical loadings are substantially higher than those from the typical nonleaching plant and reflect the added presence of the leachate stream.

#### Alternative C - Segregation and Treatment of Leachate Stream

The nonleaching streams of leaching plants are treated like those of nonleaching plants under this alternative. Treatment of the leachate stream consists of neutralization of the leachate with stack gases to pH 9.0 followed by secondary sedimentation to remove both the residual suspended solids that were present in the leachate and the suspended solids (calcium carbonate) created by the neutralization with carbon dioxide.

This alternative will result in an acceptable pH of less than 9.0, and a suspended solids level of not more than 0.15 kg/kg (0.30 lb/ton) of dust leached. Dissolved solids will remain at about their present level.

The cost of implementing Alternative C will be about \$425,000 including \$165,000 for the control of nonleaching streams and the cost of installing a stack-gas neutralization system and a clarifier (\$260,000). Operating costs of Alternative C will range from about \$35,000 to \$45,000 per year.

One of the 12 plants in the leaching subcategory is presently equipped to implement this alternative with minor adjustments in operative procedures, this plant could meet the limitations of this alternative.

#### Alternative D - Recycling of Leachate Water

This alternative consists of reducing the dissolved solids in the leachate stream by means of electro dialysis and recycling the partially demineralized leachate. The technology of alternative C must be implemented to provide a stream acceptable for electro dialysis. The concentrated brine resulting from this treatment may be evaporated for the recovery of potassium salts or contained in a suitable pond. Implementation of Alternative D will result in essentially no discharge of pollutants. None of the plants in the leaching subcategory, however, is employing the technology described as Alternative D.

#### Alternative E - Abandonment of Existing Leaching Operations'

Under this alternative, plants that presently leach kiln dust would abandon the practice and adopt either alternative A or B which will result in no discharge of pollutants. A contractor would haul the dust for about \$0.50 per ton. The value of the wasted dust would be about \$2.00 per ton. (46) Therefore, the annual cost of wasting 200 tons per day of dust that is presently leached would be \$165,000.

#### Effects of Costs on the Industry

The investment cost of \$300,000 involved in implementing control and treatment technology at an existing nonleaching plant represents 0.75 to 1.5% of the estimated replacement cost of the plant (\$20 to \$40 million). In terms of plant size, these costs represent about \$0.53 per metric ton of capacity. For plants in the leaching category, these figures may be approximately doubled.

The increased cost of manufacturing cement will range from about \$0.13 per metric ton at nonleaching plants to about \$0.21 at leaching plants.

One industry consultant has provided the typical production cost figures for 14 plants presented in Table 13 (5). The production cost ranges from \$15.11 to \$21.20 with an average of \$17.52 per metric ton. The added cost of water pollution control will thus increase production cost by less than 1.5% at plants operating at full capacity. Since these costs are largely fixed costs and, thus, must be borne at any level of production, production at less than full capacity will reflect higher added costs.

#### Energy Requirements

Because of the large energy requirement at a cement plant, about 1.25 million kg cal (5 million BTU) in fuel and about 120 kwhr of electric power per metric ton, the added power needed to operate the recycling systems is negligible (less than 0.1%).

#### Non-Water Quality Aspects

Non-water quality environmental effects of the alternative control and treatment technologies described appear minor.

Some additional solid wastes will be generated by increased use of sedimentation, but the amount will be small compared to the quantity of kiln dust normally wasted. Moreover, the relatively inert wastes are acceptable for land fill.

The increased cost of dust leaching may discourage its practice at some plants and thereby add to the solid waste load and create localized dust problems on windy days.

#### Description of Typical Plant

The typical plant used as the model for this discussion is a hypothetical wet-process leaching plant with a rated annual capacity of 520,000 kkg (580,000 tons). It operates continuously for 330 days per year and produces 1,580 kkg (1,750 tons) of clinker per day. The water flow for all cooling except finished cement is 2,360 l/min (600 gal/min); flow in the cement cooler is 1,130 l/min (300 gal/min).

About 122 kkg (134 tons) of dust collected each day is either piled in a special storage site (for non-leaching plants) or is leached for return to the kiln; flow of the leachate stream is 530 l/min (140 gal/min).

Table 13. Plant Production Costs, 1973 Dollars per Metric Ton (per ton)

Plant	A	B	C	D	E	F	G	H	I	J	K	L	M	N	Avg.
Purchased Raw Material	\$0.76 (0.69)	\$2.00 (1.82)	\$1.24 (1.13)	\$0.83 (0.76)	\$4.53 (4.22)	\$5.77 (5.25)	\$0.83 (0.76)	\$0.65 (0.59)	\$0.83 (0.76)	\$0.94 (0.85)	\$1.00 (0.91)	\$4.59 (4.17)	\$0.72 (0.65)	\$0.65 (0.59)	\$1.81 (1.65)
Freight on Limestone			1.17 (1.06)					1.11 (1.01)						1.52 (1.38)	0.27 (0.25)
Waste Dust Disposal		0.18 (0.16)													0.01 (0.01)
Labor	6.44 (5.85)	5.50 (5.00)	7.02 (6.40)	7.84 (7.23)	6.32 (5.75)	4.97 (4.52)	9.24 (8.40)	7.49 (6.80)	7.78 (7.08)	6.03 (5.48)	4.39 (4.00)	4.21 (3.84)	6.14 (5.59)	6.55 (5.96)	6.42 (5.85)
Fuel	2.40 (2.18)	2.63 (2.39)	3.11 (2.83)	2.63 (2.39)	2.63 (2.39)	1.93 (1.76)	3.80 (3.46)	3.74 (3.40)	2.52 (2.29)	1.98 (1.80)	3.39 (3.09)	2.34 (2.13)	2.28 (2.08)	2.92 (2.66)	2.74 (2.49)
Power	1.29 (1.17)	2.11 (1.92)	1.29 (1.17)	1.70 (1.55)	2.05 (1.86)	1.87 (1.70)	1.29 (1.17)	0.83 (0.75)	1.40 (1.27)	1.70 (1.54)	1.75 (1.59)	1.40 (1.27)	1.24 (1.13)	0.83 (0.75)	1.48 (1.34)
Operating and Repair Supplies	2.11 (1.92)	2.28 (2.07)	2.34 (2.12)	2.69 (2.44)	2.11 (1.92)	1.35 (1.23)	1.40 (1.27)	1.93 (1.75)	1.52 (1.38)	2.17 (1.97)	2.69 (2.44)	1.99 (1.81)	2.46 (2.24)	3.22 (2.92)	2.16 (1.96)
Taxes and Insurance	0.41 (0.37)	0.35 (0.32)	0.58 (0.53)	0.23 (0.21)	1.75 (1.59)	0.65 (0.59)	0.12 (0.11)	0.88 (0.80)	0.53 (0.48)	0.70 (0.64)	0.41 (0.37)	0.58 (0.53)	0.35 (0.32)	0.76 (0.69)	0.59 (0.54)
Miscellaneous	0.06 (0.05)	0.06 (0.05)	0.06 (0.05)	0.06 (0.05)	0.06 (0.05)	0.06 (0.05)	0.06 (0.05)	0.06 (0.05)	0.06 (0.05)	0.18 (0.16)	0.06 (0.05)	0.06 (0.05)	0.06 (0.05)	0.06 (0.05)	0.07 (0.06)
Depreciation & Depletion	1.64 (1.49)	2.81 (2.55)	1.75 (1.59)	1.99 (1.81)	1.75 (1.59)	2.63 (2.39)	0.65 (0.59)	1.40 (1.27)	1.75 (1.59)	1.87 (1.70)	2.11 (1.92)	1.75 (1.59)	3.34 (3.03)	2.05 (1.86)	1.96 (1.78)
Total Plant Cost per Metric Ton (per short ton)	15.11 (13.72)	17.92 (16.28)	18.56 (16.86)	17.97 (16.33)	21.20 (19.25)	19.23 (17.45)	17.39 (15.80)	18.09 (16.44)	16.39 (14.89)	15.57 (14.15)	15.80 (14.36)	16.92 (15.37)	16.59 (15.05)	18.56 (16.86)	17.52 (15.91)

Source: J.D. Wilson, Bendy Engineering Co., St. Louis, Missouri.

TABLE 14

## COMPARISON OF TYPICAL PLANT WITH ACTUAL PLANTS IN THE INDUSTRY

	<u>Units</u>	<u>Typical Plant</u>	<u>Mean Value</u>	<u>Number of Plants Reported</u>
Capacity	tons/year	580	578	123
Daily Production	tons	1750	1560	123
Plant Site				
Width	ft	800	775	8
Length	ft	1200	1200	8
Area	1000 sq ft	960	970	8
Water Flow				
Bearing & Mach.	gal/min	600	595	25
Cement Cooler	gal/min	300	272	21

TABLE 15

MARSHALL & SWIFT ANNUAL INDEXES OF  
COMPARATIVE EQUIPMENT COST, 1959 to 1971

(Base period: 1926 = 100)

<u>Equipment Cost Index</u>	<u>Year</u>
234.5	1959
237.7	1960
237.2	1961
238.5	1962
239.2	1963
241.8	1964
244.9	1965
252.5	1966
262.9	1967
273.1	1968
285.0	1969
303.3	1970
321.3	1971

The plant site is about 240 m x 400 m (800 x 1,200 ft) not including the quarry and dust storage site.

This typical plant varies from actual plants in the industry as shown in Table 14. The typical plant represents an average of actual plants studied. Variation in the costs involved in implementing control and treatment technology at actual plants is difficult to predict. A number of factors are involved and the actual costs will depend on the plant situation. The usual considerations such as age and capacity will be less important than such things as plant layout and the volume of water used.

### Cost Estimates

In this section are presented the assumptions used in calculating the cost of implementing control and treatment technology.

#### Inflation Index

All final costs given in Table 12 are reported in 1971 dollars. The basis for adjusting cost data is the Marshall & Swift Annual Index of Comparative Equipment Cost. (2) Table 15 presents a listing of this index for the years 1959-1971.

#### Cooling Water Assumptions

The data base used in estimating cooling water usage was obtained for 40 plants from returned questionnaires.

"Bearing cooling" includes all machinery cooling in the plants, including compressors, burner pipes, kiln bearings, grinders, etc. Twenty-five plants report an average of 1,840 l/kg (490 gal/ton). The average daily production at these plants is 1,570 kkg (1,750 tons). The flow is therefore 2,245 l/min (600 gal/min).

The temperature rise was measured to be 28°C (5°F) at a number of plants.

Cement cooler water reported for 21 plants was 945 l/kg (224 gal/ton) or 1,000 l/min (272 gal/min). This figure was verified by considering the cement. The following data were used:

$$\text{Change in } T = 121^{\circ}\text{C} - 43^{\circ}\text{C} = 78^{\circ}\text{C} \quad (250^{\circ}\text{F} - 110^{\circ}\text{F} = 140^{\circ}\text{F})$$

$$C_p \text{ (clinker)} = 0.19 \text{ cal/}^{\circ}\text{Cg}$$

Heat removed from 1 kkg of cement is:

$$0.19 \text{ cal/}^{\circ}\text{Cg} \times 1000 \text{ gKgc} / \text{kkg cal} \times 78^{\circ}\text{C} = 14,800 \text{ kgcal/kkg} \\ (53,200 \text{ BTU/ton})$$

For the typical plant this is:

$(1580 \text{ kkg/day} \times 14,800 \text{ kgcals/kg}) / 1440 \text{ min/day} = 16,200 \text{ kg cal/min. (64,000 BTU/min)}$

If the temperature rise in the water is  $14^{\circ}\text{C}$  ( $25^{\circ}\text{F}$ ) and no evaporation takes place, the flow required is calculated as:

$16,200 \text{ kgcals/min} / (14^{\circ}\text{C} \times 1 \text{ kgcals/}^{\circ}\text{Ckg} \times 1 \text{ kg/l}) = 1160 \text{ l/min. (310 gal/min)}$

which is close to the actual average of 1060 l/min (280 gal/min) reported. For present purposes, the flow for cement cooling was taken as 1130 l/min (300 gal/min).

If both cooling streams are combined we have:

(bearing cooling) 2270 l/min @  $2.8^{\circ}\text{C}$  (600 gal/min @  $5^{\circ}\text{F}$ )  
(cement cooling) 1135 l/min @  $14^{\circ}\text{C}$  (300 gal/min @  $25^{\circ}\text{F}$ )  
combined 3405 l/min @  $6.5^{\circ}\text{C}$  (900 gal/min @  $11.7^{\circ}\text{F}$ )

To provide for extremely warm weather we will assume a temperature rise of  $8.4^{\circ}\text{C}$  ( $15^{\circ}\text{F}$ ).

#### Cooling Tower

Guthrie (5) gives the base cost of a cooling tower for  $8.4^{\circ}\text{C}$  ( $15^{\circ}\text{F}$ ) temperature rise and 3785 l/min (1000 gal/min) flow as \$45,000. This includes: cooling tower, concrete basin, pumps and drives, field erection, and indirect costs. The bare-module cost will be 1.75 x \$45,000 or \$78,750. Contingencies and contractor fees of 20% are added for a total of \$94,000, total installed cost (1968-\$).

#### Cooling Pond Costs

Cost information provided by a single company on a spray pond to handle their cooling water (the production rate is 1090 kkg/day (1200 ton/day) and flow is typical) is \$100,000 total installed cost in 1965. For the typical plant production of 1590 kkg/day (1750 ton/day) and a 0.6 exponential scaling factor, the cost for the typical plant would be \$125,000 (1965\$).

The size of an evaporative cooling pond required for this application is determined by climatic conditions. For midsummer conditions of 50% relative humidity,  $25^{\circ}\text{C}$  ( $77^{\circ}\text{F}$ ) average temperature, wind velocity of 8 km/hr (5 m/hr), and solar radiation of 353 kgcals/hr/sq m (130 BTU/hr/sq ft), the equilibrium temperature in a cooling pond would be  $32^{\circ}\text{C}$  ( $90^{\circ}\text{F}$ ). With inlet temperature of  $46^{\circ}\text{C}$  ( $115^{\circ}\text{F}$ ) and outlet temperature of  $38^{\circ}\text{C}$  ( $100^{\circ}\text{F}$ ), the area of the cooling pond would be 4100 sq m or about one acre. For 24-hour holdup time the depth of the pond must be 1.19 m (3.9 ft). Such a pond would cost about \$15,000 (1971-\$) (6) and should be adequate for the typical plant.



## Piping Costs

Estimates of piping costs were made for the typical plant illustrated in Figure I by assuming that a cooling tower will be located near the kiln area opposite the slurry tanks. The total length of piping will be about 915 m (3000 ft), including 244 m (800 ft) from the raw mill to the finish mill, 427 m (14000 ft) to connect the opposite ends of these buildings (returns), and 244 m (800 ft) for twelve 20.3 (66.7 ft) runs to the kiln area (feed and return to 4 piers, burner pipe and gas analyzer).

A rough fitting count includes 28-90° ells and 4 valves. Allowances for contingencies and 42 and 7 were used in calculating fitting costs.

Cost of piping was calculated on per lineal meter basis from Guthrie (5) assuming 0.23 m (8" schedule 40) pipe, a 0.61 m (2 ft) wide by 1.83 m (6 ft) deep trench, machine backfilled with hand dressing. Summary follows:

	Cost/m	Cost/lin ft
pipe (materials)	15.25	5.00
pipe ( installation, yard and offsite)	7.62	2.50
trench (machine)	1.92	.63
backfill @ 1.18/cu m (1.56/cu yd)	<u>2.10</u>	<u>.69</u>
Total	26.89	8.82/lin ft.

Cost of fittings from rough count including 50% contingency:

42 ells material @ \$35.00 =	\$1,470
42 ells installed @ \$11.50 =	483
7 gate valves material @ \$500.00 =	3,500
7 gate valves installed @ \$60.00 =	<u>420</u>
Total fitting =	\$5,873

Therefore, total cost of installed piping is:

pipe 915 x 26.89 =	24,622
fitting	<u>5,873</u>
	\$30,495

To allow for finding and plugging existing lines, a 50% contingency is provided to bring the total cost of piping at the plant to about \$50,000 (1968 dollars).

Because a cooling pond may have to be located some distance say 1,000 ft from where the cooling tower would have been, the cost of piping is the same as for the cooling tower, plus an additional 610m at 26.89 per m. The cost of piping a cooling pond is therefore

cooling tower piping	\$50,000 plus
610 m @ \$26.89/m	<u>16,400</u>

Total \$66,400 (1968-\$)  
Containment of Runoff from Piles of Dust,  
Coal, Clinker or other Material

Fifty-eight plants report an average of 0.0764 metric tons of dust discarded per metric ton of clinker produced. Although the bulk density of waste kiln dust varies somewhat, for these estimates we used the average bulk density we measured, which was 562 kg/cu m (35 lb/cu ft).

The typical plant would discard 66,000 cu m of dust per year (82,600 cu yd/year). If the angle of repose of the sides of the pile of waste kiln dust is  $18\frac{1}{4}$ , a dust pile in the shape of a square-based truncated pyramid with sides 274 m (900 ft) long at the base would provide storage for 690,000 cu m (24,340,000 cu ft) when the height of the truncated pyramid is 12 m (40 ft). This volume is adequate for more than 10 years of storage in kiln dust. The area of the base of a truncated pyramid that size is 7.5 hectares (18.6 acres).

The assumptions made for estimating the cost of constructing facilities for containment of the runoff from the waste-dust pile at the typical plant are given below:

1. The estimates of cost are based on a 10-year, 24 hour event in which 0.114 m (4.5 in) of rain falls.
2. The surface of the land to be used as a storage area has a 3 degree grade.
3. The soil is permeable so that an impermeable sub-base must be prepared. The impermeable base is prepared by grading 0.6 m (2 ft) from a square that is 1,000 feet on a side. This graded surface is back-filled, graded level, and compacted to a depth of 0.15 m (5 in). Polyethylene sheeting is placed on the dikes described later. Overlaps of 0.3 m (12 in) at the seams of the sheeting are used. A 0.45 m (1.5 ft) layer of earth is then graded and compacted over the polyethylene, including the face of the dikes described later.
4. Dikes are constructed across the downhill end of the 305-meter (100 ft) square storage areas, and for 84 m (275 ft) up each side. The dikes will be 2.5 m (8.2 ft) high at the crest. The crest will be 1.5 m (5 ft) wide, and the total width of the base of the dikes, which are trapezoidal in cross-section, will be 12 m (40 ft). The dike at the downhill end of the storage area is provided with a concrete sluiceway so that water can overflow in the event of a catastrophic rainfall. The crest of the sluiceway is 1.5 m (5 ft) above the grade level of the base of the dike. The dikes are constructed prior to placement of the

polyethylene sheets so that the upstream faces of the dikes can be covered with polyethylene, and then earth, and compacted.

5. Trenches are dug across the uphill end of the storage area and along each side to diver runoff into the diked area.
6. Neutralization facilities are used to maintain the pH of any overflow from the diked area within proper limits. These facilities include a 3.8 cu m (1000 gal) tank to hold sulfuric acid, a metering pump, and a pH sensor and controller along with necessary piping and wiring. Mixing of the acid with overflow from the containment pond, when overflow occurs, is accomplished in the downstream trough of the sluiceway. The metering pump is controlled by a pH controller with the sensor downstream from the sluiceway. The pH controller will activate the pump to pump sulfuric acid in proportion to the amount the pH exceeds a pre-selected set-point.
7. A storage area of 0.404 hectares (1 acre) is provided for storage of coal and other materials. The normal inventory of coal (one-week's supply) will occupy far less than 0.404 hectares. This storage area is provided with trenches, dikes, and an impermeable sub-base in the same manner as described for the kiln dust storage area, and the same assumptions for estimating costs apply.

With the foregoing assumption the total costs of preparing the storage area for waste kiln dust is estimated to be \$115,000, including costs of \$60,000 for preparing the impermeable sub-base, \$15,000 for neutralization facilities, \$3,000 for the sluiceway, \$7,500 for dikes, \$2,000 for the trenches, and \$27,500 (30% of the sum of the above costs) as contingency. The unit costs used in estimating the above cost were: \$1.18/cu m (\$0.90/cu yd) for grading, filling and compacting (7); \$0.27/sq m (\$0.025/sq ft) for purchasing 10-mil polyethylene film (quoted price); and \$1.65/lineal meter (\$0.50 lineal ft) for machine trenching (7).

If the soil at a particular plant site is impermeable so that no preparation of sub-base is required, the total cost of the storage area is estimated to be \$36,000, based on the same assumptions and the same unit costs described above.

The total cost of the 0.404 hectare (1 acre) area for storing coal and other materials is estimated to be \$17,000, including the costs for preparing impermeable sub-base (\$3,300), trenches and dikes (\$1,100), the sluiceway and neutralization facilities (\$8,500), and a 30% contingency (\$3,900). The neutralization facilities for any overflow from this diked area includes a storage hopper and a feeder for lime,

and a pH-controller and sensor. Lime will be required instead of acid because any runoff from a coal storage pile will be acidic in nature.

#### Stack Gas Carbonation and Settling of Leachate Stream

One plant reported a 1962 cost of \$175,000 to install a stack gas carbonation system with associated thickener and clarifying basins leachate streams. Adjustment for size of typical plant and inflation brings the 1971 investment cost to \$260,000.

Operating costs are reported as approximately \$15,000 per year.

#### Estimated Cost of Electrodialysis (ED)

Assumptions used in estimating the cost of ED are as follows:

Flow 757,000 l/day (200,000 gal/day)  
K<sub>2</sub>S<sub>0</sub>4 to be removed = 1.209 eq/sec (10 tons/day)

For technical details, Lacey & Loeb (30) should be consulted.

With the 85% efficiency given in Reference 30 the electric current required is:

$$1.209 \text{ eq/sec} \times (96500 \text{ amp sec}) / (0.85) = 137,000 \text{ amp}$$

To estimate the number of stacks required, a polarization parameter ( $i/N$ , where  $i$  = current density and  $N$  = normality) of 250 (conservative) will be assumed. The current per cell pair is, therefore:

( $i/N$ , where  $i$  = current density and  $N$  = normality) of 250 (conservative) will be assumed. The current per cell pair is, therefore:

$$300 \text{ (ma/sq cm)} / (\text{eq/l}) \times 0.11 \text{ eq/l} \times 2600 \text{ sq cm/pair} \\ = 85.8 \text{ amp/cell pair}$$

Since the total current is 137,000 amp, 1600 (137,000/85.8) cell pairs are required, or 8 stacks of 200 cell pairs.

Quotation from Aqua Chem, Inc. (January, 1971)

WD-10-4 stacks (without membranes)

50 cell pair stack \$3,185 each  
100 cell pair stack \$4,225 each

Therefore, each additional 50 cell pairs will cost \$1,040. A 200 cell pair stack will cost \$4,225 + 2,080 = 46,305. If 8 stacks are required and 2 are on standby, cost will be 10 x \$6,305 or \$63,050 without membranes.

A suitable rectifier will cost about \$13,500 (46).

Pumps will cost \$5,400 (2 in service, 2 standbys at \$1,350 each).

Membranes will cost no more than \$37.70 sq m (\$3.50/sq ft), based on 1970 quotations from Tokuyama Soda Co., Ltd., of \$18.85/sq m (\$1.75/sq ft) and from Ionac Chemical Co., Inc. of \$37.70/sq m (\$3.50/sq ft). The cost of the 1598 sq m (17,200 sq ft) of membranes needed is \$50,200.

Required sand filters will cost about \$18,000.

The cost of a 13.72 m (45 ft) clarifier was quoted by Elmco, Inc., to be \$23,000.

It is estimated that a total of four turbo-agitated gas-contacting tanks will be needed for the two stages of carbonation. The cost of the four tanks is estimated to be \$16,000 (34).

Stacks	\$63,050
Membranes	50,200
Rectifier	13,500
Filter	18,000
Pumps	5,400
Secondary clarifier	23,000
Carbonators	<u>16,000</u>
	\$189,150 Principal Items of Equipment (PIE)

Erection & Assembly = 30% of PIE or \$56,745. Contingencies of 10% PIE and 10% E & A = 24,690 bringing the total to:

PIE	\$189,150
E & A	56,745
Contingencies	<u>24,690</u>
	\$270,585
Engineering (10%)	<u>27,050</u>

Total Investment for ED - \$297,635 (1971-\$)

#### Cost of Capital and Depreciation

Since the return on assets for the cement industry varies from 3 to 10% and the interest on borrowed money is about 8%, capital costs are assumed at a straight 8% per year over a ten year period. Depreciation is on a 10 year straight-line basis.

#### Operating Costs

Operating costs for ED will consist of power, replacement membranes and labor.

At a stack voltage of 200 and a current of 85.8 amps, power is 412 kwhr/day for ED, pumping will add about 60 kwhr/day. In addition, about 725 kwhr/day will be needed for the carbonators.

Some manufacturers of membranes guarantee a membrane life-time of 5 years for desalination, but a conservative estimate of 2 years life expectancy was assumed. On this basis the annual cost of membrane replacement is \$25,100. Labor is estimated at 100 man-hour/stack/year or about 1000 man-hours at \$6.00/hr for a total labor of \$6,000/year. Annual operating cost of ED is therefore:

330 days power at 1¢/kwhr \$3,850

Replacement of membranes and labor \$3,850

For a total annual operating cost of about \$35,000 which is about 9% of the total investment for ED.



## SECTION IX

### EFFLUENT REDUCTION ATTAINABLE THROUGH APPLICATION OF THE BEST PRACTICABLE CONTROL TECHNOLOGY CURRENTLY AVAILABLE -- EFFLUENT LIMITATIONS GUIDELINES

#### Introduction

The effluent limitations which must be achieved by July 1, 1977 are to specify the degree of effluent reduction attainable through the application of the best practicable control technology currently available (BPCTCA). This technology is generally based upon the average of the best existing performance by plants of various sizes, ages and unit processes within the industrial category or subcategory or both. This average is not based upon a broad range of plants within the cement manufacturing industry, but based upon performance levels achieved by exemplary plants. Consideration must be given to:

- a. The total cost of application of technology in relation to the effluent reduction benefits to be achieved from such application.
- b. The size and age of equipment and facilities involved.
- c. The processes employed.
- d. The engineering aspects of the application of various types of control techniques.
- e. Process changes.
- f. Non-water quality environmental impact (including energy requirements).

Best practicable control technology currently available emphasizes treatment facilities at the end of a manufacturing process but includes the control technology within the process itself when the latter is considered to be normal practice within an industry.

A further consideration is the degree of economic and engineering reliability which must be established for the technology to be "currently available." As a result of demonstration projects, pilot plants and general use, there must exist a high degree of confidence in the engineering and economic practicability of the technology at the time of commencement of construction or installation of the control facilities.

#### Identification of BPCTCA

##### Nonleaching Subcategory

For the nonleaching subcategory of the cement industry, BCTCA is recycling and reuse of waste waters and containment of runoff from coal piles and discarded kiln dust. An alternative to recycling and reuse is



the isolation of cooling water from possible sources of contamination. In any case, the application of this technology will result in essentially no discharge of pollutants. To implement this requires:

1. Recycling of cooling water through the use of cooling towers, cooling ponds or completely closed package systems, or isolation of cooling water circuits from possible sources of contamination by the use of enclosures, and control of ambient dust within the plant, or reuse of cooling water for preparation of slurry in wet-process plants.
2. Containment and return-to-process of slurry spills and slurry tank wash waters at wet-process plants.
3. Recycling or evaporation of water used to slurry waste dust.

#### Leaching Subcategory

For the leaching subcategory, BPECTA is reduction of suspended solids and neutralization of the leaching streams and application of the same technology as outlined for plants in the nonleaching category for the remaining streams. Application of this technology, neutralization and sedimentation should result in a suspended solids loading of not more than 0.4 kg/kkg (0.8 lb/ton) of dust leached, and a pH of not more than 9.0. Since the amount of dust leached rather than the amount of product produced determines water usage for these streams, limitations on the leaching stream are expressed in these terms.

In addition to the implementation required for the nonleaching streams, implementation for the leaching streams requires:

1. Segregation of the leaching stream from all other streams.
2. Installation of suitable facilities to neutralize the leachate stream with stack gas to a pH of 9.0
3. Installation of a secondary clarifier or settling basin to reduce suspended solids to not more than 0.4 kg/kkg (0.8 lb/ton) of dust leached.

Limitations resulting from the application of this technology will not result in a reduction in total dissolved solids. The extensive treatment required to remove dissolved solids and the lack of current practicable technology for treatment precludes setting limitations for dissolved solids to be achieved by July 1, 1977.

#### Materials Storage Piles Runoff Subcategory

Installation of suitable dikes to contain runoff from coal piles and kiln dust piles or overflow from ponds where waste dust is slurried or

neutralization and sedimentation of such runoff where it cannot normally be contained.

Storage piles of material other than high-alkali kiln dust should be provided with dikes and sluiceway-neutralization facilities and suspended solids control to control the discharge of pollutants to navigable waters in the event of a 10 year 24 hour rainfall event.

The application of this technology should control runoff discharges to a pH between 6.0 to 9.0 and total suspended solids to 50 mg/l or less.

#### Rationale for the Selection of BPCTCA

##### Age and Size of Plants

As discussed in Section IV, the age and size of a cement plant do not bear directly on the quantity or quality of waste water generated.

The age of a plant is not very meaningful because new kilns and other facilities may be added years after the original plant start-up.

Size of a plant, as measured by rated capacity, is not applicable because variations in the type of equipment and plant management practices are reflected in widely varying water requirements.

These considerations, coupled with verification of exemplary performance at plants of various sizes and ages, indicate that size and age do not bear on the practicality of zero discharge of pollutants.

##### Total Cost of Application in Relation to Effluent Reduction Benefits

Based on the information contained in Section VIII of this report, the total investment for all plants in the nonleaching subcategory would be about \$35,000,000 to achieve zero discharge of pollutants. This figure is estimated on the basis of the known 151 plants in this subcategory of which about 35 already report no discharge of pollutants. For the remaining 116 plants the typical cost of \$300,000 per plant is assumed. The 12 plants in the leaching subcategory will require a total of about \$5.1 million. This includes the same per plant expenditures as above plus an additional \$225,000 per plant for neutralization and sedimentation facilities.

Thus, the estimated maximum expenditures for the industry as a whole are about \$40 million. On a per-plant basis, cost will range from 0.75 to 2% of the \$20 to \$40 million estimated average cost of building a new plant. The anticipated increase in operating costs, including depreciation, amounts to about \$0.13 per metric ton of cement (with a current reported cost of from \$15.11 to \$21.20 per metric ton).

##### Processes Employed and Engineering Aspects

All plants in the industry use the same or similar production methods, giving similar discharges. There is no evidence that operation of any

current process or subprocess will substantially affect capabilities to implement best practicable control technology currently available.

#### Engineering Aspects of Control Technique Applications

This level of technology is practicable because at least 23 percent of the plants in the nonleaching subcategory are now achieving the effluent reductions set forth herein. The concepts are proved and available for implementation, and may be readily adopted through adaptation or modification of existing production units.

Of the plants in the leaching subcategory, none is presently achieving the effluent quality that is specified herein. However, each of the control techniques is presently employed at individual plants, and in proper combination could achieve the prescribed effluent reduction if applied at all plants in the leaching subcategory.

#### Process Changes

No process changes are envisioned for implementation of this technology for plants in either subcategory.

#### Non-Water Quality Environmental Impact

The impacts upon non-water elements of the environment include:

1. An increase in the solid wastes generated by the industry due to collected sludge
2. A potential limited effect upon ambient air quality

The former is relatively minor in view of the large quantities of kiln dust presently being wasted. The latter arises because the cost of implementing the control measures necessary at leaching plants or at plants that slurry discarded dust may encourage these plants to pile waste dust which can create localized dust problems on windy days.

The enhancement to water quality management provided by these control measures substantially outweighs the air and solids waste effects. Moreover, techniques are available to control air-borne dust from piles, and the solid wastes from this industry are relatively inert and are acceptable as land fill and for uses such as sub-bases for secondary roads and parking lots.

#### Materials Storage Piles Subcategory

Retention and neutralization of runoff refers to runoff from piles of coal and kiln dust (or other waste material) and any piled raw materials. The runoff from these piles should be segregated from other plant runoff such as roof drains. The intent is to provide retention and neutralization of runoff from such piled materials. The basis for design is to be a 10-year 24-hour rainfall event.

Retention of runoff may be achieved by dikes, ditches or other means to divert and direct runoff into a retention pond that will serve to remove easily settleable solids and will provide relatively uniform flow to the neutralization process. The pH of the effluent from the retention pond will be controlled by addition of appropriate neutralizing agents (e. g. sulfuric acid for runoff from kiln dust piles and lime for runoff from coal piles) to the waste water. Industrial instruments for monitoring and controlling pH are available and directly applicable to this situation. The costs of \$30,000 for controlling pH of runoff water in a typical plant were based on the system described above.

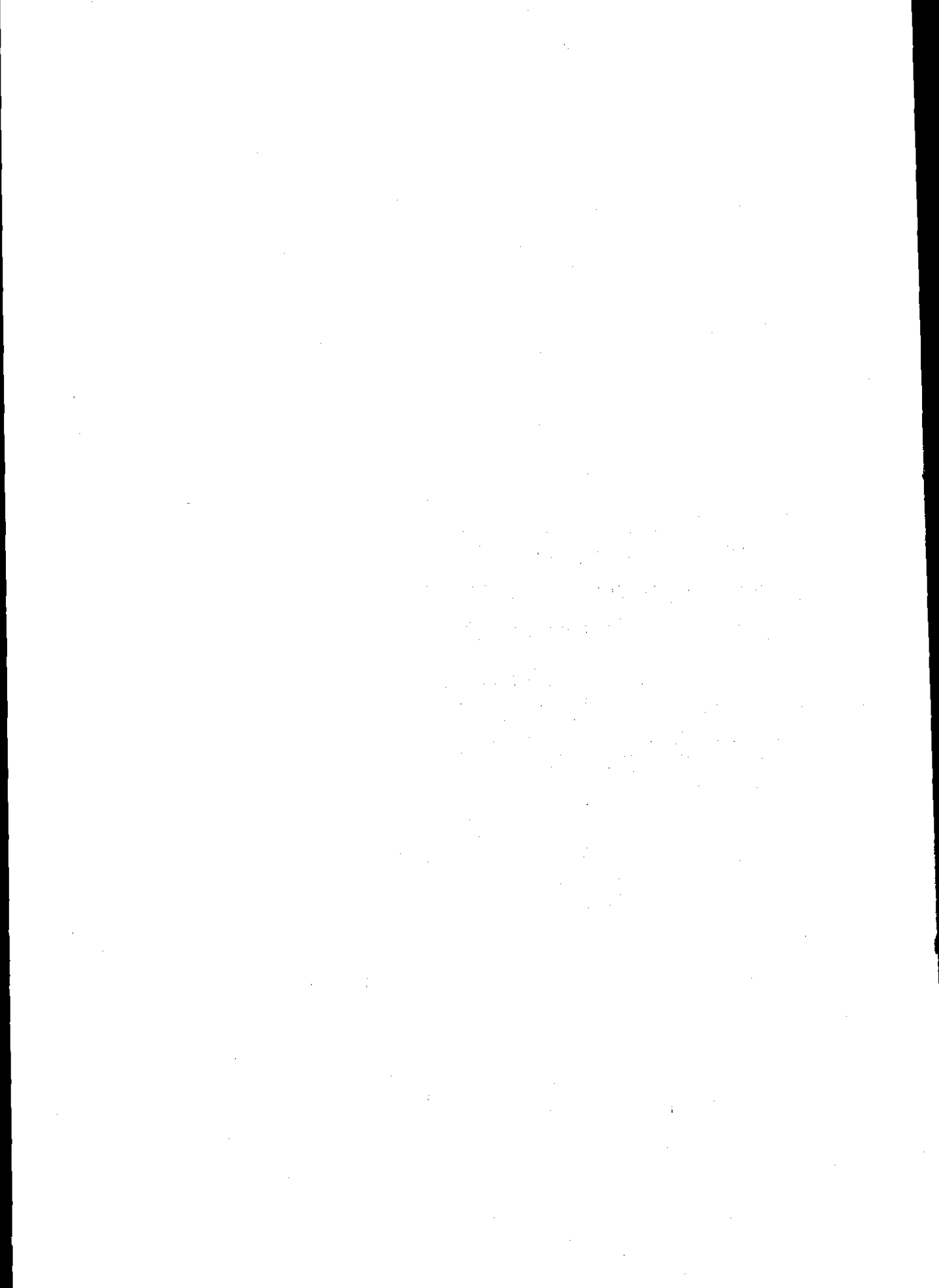

## SECTION X

### EFFLUENT REDUCTION ATTAINABLE THROUGH THE APPLICATION OF THE BEST AVAILABLE TECHNOLOGY ECONOMICALLY ACHIEVABLE EFFLUENT LIMITATIONS GUIDELINES

#### Introduction

The effluent limitations which must be achieved by July 1, 1983 are to specify the degree of effluent reduction attainable through the application of the Best Available Technology Economically Achievable (BATEA). This technology can be based on the very best control and treatment technology employed by a specific point source within the industry category and/or subcategory or technology that is readily transferable from one industry process to another. A specific finding must be made as to the availability of control measures and practices to eliminate the discharge of pollutants, taking into account the cost of such elimination.

Consideration must also be given to:

1. The age of the equipment and facilities involved
2. The process employed.
3. The engineering aspects of the application of various types of control technologies.
4. Process Changes
5. Cost of achieving the effluent reduction resulting from the technology.
6. Nonwater quality environmental impact (including energy requirements).

The best Available Technology Economically Achievable also assesses the availability in all cases of in-process controls as well as the control or additional treatment techniques employed at the end of a production process. A further consideration is the availability of processes and control technology at the pilot plant, semi-works, or other levels, which have demonstrated both technological performances and economic viability at a level sufficient to reasonably justify investing in such facilities. Best Available Technology Economically Achievable is the highest degree of control technology that has been achieved or has been demonstrated to be capable of being designed for plant scale operation up to and including no discharge of pollutants. Although economic factors are considered, the costs for this level of control are intended to be top-of-the-line of current technology subject to limitations imposed by economic and engineering feasibility. However, Best Available Technology Economically Achievable may be characterized by

some technical risk with respect to performance and costs and, thus, may necessitate some industry development prior to its application.

#### Identification of BATEA

##### Nonleaching Subcategory

For plants in the nonleaching contact subcategory, the effluent limitations reflecting this technology are essentially no discharge of pollutants as developed in Section IX.

##### Leaching Subcategory

Based upon the information presented in Sections III through VIII of this report, the degree of effluent reduction attainable through the application of BATEA is concluded to be essentially no discharge of process waste waters to navigable streams.

This technology consists of treatment and reuse of water from the leachate streams within the operation. Implementation requires the development of a practical system for the concentration and removal of the alkali salts in the leachate stream. Such a system, outlined in Section VII, might consist of electro dialysis, evaporation, or a combination of both. While the technical and economic feasibility of these methods remains to be demonstrated in this industry, the components of this technology have been sufficiently demonstrated to justify the development work despite the technical and economic risks.

##### Materials Storage Piles Runoff Subcategory

For plants in the materials storage piles runoff subcategory, the effluent limitations reflecting this technology are the same as developed in Section IX for BPCTCA.

#### Rationale for Selection of BATEA

For nonleaching plants, the rationale was developed in Section IX.

For leaching plants, the effluent limitation of "essentially no discharge" is based on the availability of transferrable technology, electro dialysis. While this technology is not presently in use in the cement industry, it is considered the best available and economically achievable because:

1. It is currently used on a commercial scale for recovery of salt from sea water, a more rigorous operation.
2. The total costs of implementing this technology, about a \$300,000 investment and a \$35,000 annual operating cost, appear to be within the range of economic practicality in view of the pollution reduction benefits obtained.

3. The process appears to be technically sound as developed in Section VII.

For the materials storage piles subcategory, the technology is identical to best practicable control technology currently available as developed in Section IX.





## SECTION XI

### NEW SOURCE PERFORMANCE STANDARDS AND PRETREATMENT STANDARDS

#### New Source Performance Standards

A new source is defined as "any source, the construction of which is commenced after the publication of proposed regulations prescribing a standard of performance." Technology to be utilized for new sources has been evaluated by considering the control technology identified as Best Available Technology Economically Achievable in Section X and considering the availability of alternative production processes and operating methods.

The effluent limitation for new sources in the nonleaching subcategory is essentially no discharge of pollutants to navigable waters as developed in Section IX. For leaching plants, the standard is reduction of suspended solids to less than 0.4 kg/kg (0.8 lb/ton) of product and pH to 9.0 as developed in Section IX. For plants in the materials storage piles runoff subcategory the effluent limitation is no discharge of pollutants from materials storage piles runoff to the navigable waters.

The technology utilized should be that defined as Best Practicable Control Technology Currently Available. After the necessary developmental work is performed the technology defined as Best Available Technology Economically Achievable for leaching plants may eventually provide a more effective and economical treatment system and the performance standards should then be revised accordingly.

For the materials storage piles subcategory, the new source performance standards shall be no discharge of process waste water pollutants to the navigable waters.

#### Pretreatment Standards

In addition to the effluent limit for new sources, those waste water characteristics have been identified which would interfere with, pass through, or otherwise be incompatible with a well designed and operated publicly owned waste water treatment plant. A determination has been made of the guidelines for the introduction of such wastes into the treatment plant.

In general, municipal treatment systems are not available to cement plants due to the lack of sewer collection systems and the high value of land in the vicinity of municipalities. If the situation does arise, the major troublesome characteristics of waste water as presented in Section V are the dissolved solids concentration of these wastes.

In order to avoid treatment system malfunctions, a judgement should be made on an individual basis as to the amount of dissolved solids which should be allowed to enter a particular treatment system along with the

normal municipal waste load. Consideration should be given to the specific type and concentration of dissolved solids, the present municipal waste load, and the treatment system's capacity, to insure that a proper degree of dilution is maintained.

## SECTION XII

### ACKNOWLEDGEMENTS

The Environmental Protection Agency wishes to acknowledge the contributions to this project by the Southern Research Institute (SRI) Birmingham Alabama. The work at SRI was performed under the direction of George Morneau, Project Manager; assisted by Thomas A. Davis, Senior Chemical Engineer; Robert E. Lacy, Senior Chemical Engineer; Don Hooks, Assistant Chemist; and John Roden, Associate Chemist. Other contributing SRI staff members included Walter R. Dickson, Research Chemist; Samuel Edward, Chemical Research Technician; and Gretchen Engquist, Statistical Research Technician.

Appreciation is expressed to those in the Environmental Protection Agency who assisted in the performance of the project: F. E. Kimball and John Moebes, Region IV; Arthur H. Mallon, OR&D Headquarters; James A. Santrach, OR&D, NERC, Corvallis; Allen Cywin, Ernst P. Hall and George R. Webster, Effluent Guidelines Division; Taylor O. Miller, and Nancy Speck, OGC, Headquarters and many others in the EPA regional offices and research centers who assisted in providing information and assistance to the project. Special acknowledgement is made of the assistance given by Mr. John Riley, Project Officer, whose leadership and direction on this program are most appreciated and to Patricia J. Dugan and other editorial assistants in the Effluent Guidelines Division, EPA, who prepared this document for printing.

Acknowledgement is made of contributions by consultants Lyle Hensen and Joseph Wilson, and also the staff of the Portland Cement Association, specifically Ethel Lyon, Cleve Schneeberger, Joseph Shideler, George Verbeck, and Joseph Walker.

Acknowledgement is also made of the many individuals in the industry who cooperated in providing information essential to this study. Special appreciation is expressed to Bruce Kester, Harlan Powledge, Jack Gilliland and the other industry personnel who participated in group discussions and gave of their time during plant visits.



### SECTION XIII

#### REFERENCES

##### CEMENT MANUFACTURING

1. "The Making of Portland Cement," Portland Cement Association (1964).
2. "Portland Cements," Portland Cement Association (1971).
3. H.S. Frolich, "The Development of Cement Manufacture in the Last 50 Years," Pit and Quarry, 59, 301 (Oct., 1966).
4. P.K. Mehta, "Trends in Technology of Cement Manufacture," Rock Product, 73, 83 (March, 1970).
5. J.D. Wilson, Bendy Engineering Co., Letter to G.A. Morneau, Southern Research Institute, May 24, 1973.

##### STATISTICAL AND COST DATA: CEMENT INDUSTRY

6. "U.S. Industrial Outlook 1972 with Projections of 1980," U.S. Department of Commerce, 1972, p. 12.
7. R.A. Grancher, "Cycling with Cement," Rock Products, 75, 66 (Dec. 1972).
8. R.A. Grancher, "Cement's Second Century," Rock Products, 74, 100 (Oct. 1971).
9. Anon., "Cement: Increase Anticipated for Cement Demand and Plant Capacity Planning," Rock Products, 74, (Dec. 1971).
10. "World Cement Directory, 1972," International Publications Service, New York, 1972.
11. "American Cement Director, 1972," Bradley Pulverizer Co., Allentown, Pa. (April, 1972).
12. S. Levine and E.W. Stearn, "The Year Ahead 1973," Rock Products, 75, 53 (December, 1972).
13. J.P. Wynen, "Economics of Cement Plant Design," Rock Products, 78 (Feb. 1971) and 74, 70 (March, 1971).

##### KILN DUST UTILIZATION AND DISPOSAL

14. B. Kester, "The Alkali Problem," Presented to the Portland Cement Association, General Technical Committee, (Fall, 1972).
15. Anon., "Potash from Cement at the Riverside Portland Cement Company," Metallurgical and Chemical Engineering, 701, (June 15, 1917).

16. J.M. Wolfe, "Kiln Dust-Properties and Handling," Pit and Quarry, 55, 136 (March 1964).
17. C. H. Goller, Jr., "Is Dust Leaching Worthwhile," Pit and Quarry, 59, 122 (August 1966).
18. W.R. Dersnah and C.F. Calusen, "Can That Dust be Used Again?" Pit and Quarry, 50, (Sept., 1958).
19. T.L. McCubbin, "Dust Control Techniques for a Portland Cement Plant," Mineral Processing, 10, 24, (May, 1969).
20. F.W. Cohrs, "How the Newer Plants Handle Kiln Dust Disposal," Rock Products, 74, 50 (Nov., 1971).
21. Termachos Patzias, "Extraction of Potassium Oxide from Cement Kiln Flue Dust," Doctoral Dissertation, Wayne State University (1959).
22. G.C. Lindsay, "Don't Throw Away Dust," Rock Products, 65, 87 (July, 1962).
23. "Panel Session on Dust Returned to Rotary Kilns," Portland Cement Association (Jan., 1966).

AIR AND WATER POLLUTION STUDIES: CEMENT INDUSTRY

24. "The Cement Industry: Economic Impact of Pollution Control Costs," Prepared by the Boston Consulting Group, for the U.S. Environmental Protection Agency (Nov., 1971).
25. "Background Information for Proposed New-Source Performance Standards: Steam Generators, Incinerators, Portland Cement Plants Nitric Acid Plants, Sulfuric Acid Plants," U.S. Environmental Protection Agency, Office of Air Programs (Aug., 1971).
26. "The Industrial Wastes Studies Program: Summary Report on the Flat Glass, Cement, Lime, Gypsum and Asbestos Industries," U.S. Environmental Protection Agency (Jan., 1972).
27. "Regional Guidance for Permit Preparation: Cement, Lime, Gypsum, Asbestos and Flat Glass Industries," U.S. Environmental Protection Agency (Sept. 21, 1972).
28. "Industrial Waste Study Report: Flat Glass, Cement, Lime, Gypsum, and Asbestos Industries," Prepared by Sverdrup & Parcel and Associates, Inc. for the U.S. Environmental Protection Agency (July, 1971).
29. T.E. Kreichelt, "Atmospheric Emissions from the Manufacture of Portland Cement," U.S. Department of Health, Education, and Welfare (1967).

#### WASTEWATER CONTROL AND TREATMENT

30. R.E. Lacey and S. Loeb, "Industrial Processing with Membranes," John Wiley and Sons, Inc., New York (1972).
31. Henri Chidiac, "Water Pollution Control at Dundee's Clarksville, Mo., Plant," Pit and Quarry, 60, (Oct. 1968).
32. J.D. Wilson, "Controls Spark Waste Water Delimena," Rock Products, 76, 92 (March, 1973).
33. G. Rey, W.J. Lacy, A.Cywin, "Industrial Water Reuse: Future Pollution Solution," Environmental Science and Technology, 5, 763 (Sept., 1971).
34. K.M. Guthrie, "Modern Cost Engineering Techniquet," McGraw-Hill Book Co., New York (1970).
35. W.L. Patterson, et. al., "Estimating Costs and Manpower Requirements for Conventional Wastewater Treatment Facilities," U.S. Environmental Protection Agency (Oct., 1971).
36. "Pretreatment Guidelines for the Discharge of Industrial Wastes to Municipal Treatment Works," Prepared by Roy F. Weston, Inc. for the U.S. Environmental Protection Agency (Nov. 17, 1972).
37. "Commodity Data Summaries," U.S. Department of Interior, Bureau of Mines, pp. 114-115 (Jan., 1973).
38. Chemical Marketing Reporter, 203, (Feb. 12, 1973).
39. E.L. Quinn and C.L. Jones, "Carbon Dioxide," Reinhold Publishing Co., New York (1936).
40. "Methods for Chemical Analysis of Water and Wastes," U. S. Environmental Protection Agency (1971).
41. "Water Measurement Manual," U.S. Department of the Interior, Bureau of Reclamation (1971).
42. Japanese Patent 224611 (August 31, 1956), "Process for Concentration of inorganic electrolyte solutions."
43. Japanese Patent 217865 (November 28, 1955), "Electro-dialyzer for Concentration of Electrolytic Solutions."
44. Japanese Patent 236354 (November 4, 1957), "Process for Concentration Potassium Salts."
45. T. Nishiwaki, "Concentration of Electrolytes Prior to Evaporation With an Electromembrane Process." Chaper 6 in Industrial Processing with Membranes, R. Lacey and S. Loeb, editors, John Wiley and Sons, Inc. New York (1972).



46. Private Communication, J.D. Wilson, Bendy Engineering.
47. Letter of J.D. Wilson, Bendy Engineering to G.A. Morneau, Southern Research, May 24, 1973.
48. "Marshall & Swift Annual Indexes of Comparative Equipment Costs, 1953 to 1971," Chem. Eng., Nov. 13, 1972, p. 170.
49. Bruce Kester, private communication, Missouri Portland Cement Co.
50. J. Perry (ed.), "Chemical Engineers Handbook (3rd Edition)," McGraw-Hill Book Co., New York, 1950.
51. K.M. Guthrie, in "Modern Cost Engineering Techniques," Edited by H. Popper, McGraw-Hill Book Co., New York, 1970.
52. W. L. Patterson and R.F. Banker, "Estimating Costs and Manpower Requirements for Wastewater Treatment Facilities," Final Report to EPA, Contract 14-12-462, October, 1971.
53. H.E. Mills, in "Modern Cost Engineering Techniques," Edited by H. Popper, McGraw-Hill Book Co., New York, 1970.
54. R.E. Lacey and S. Loeb, "Industrial Processing with Membranes," Wiley-Interscience, New York, 1972.
55. "Joint Construction Sediment Control Project," EPA Grant No. 15030 FMZ, State of Maryland, August 1973. (EPA-R2-72-015)
56. "Studies on Limestone Treatment of Acid Mine Drainage I and II," FWPCA DAST-33 14010 EIZ 01/70 (with references).

## SECTION XIV

### GLOSSARY

#### Definitions and Terminology

**Alkali:** A substance having marked basic properties, generally sodium or potassium oxides or hydroxides in kiln dust.

**Alkalinity:** A quantitative measure of the capacity of liquid or suspensions to neutralize strong acids or to resist the establishment of acidic condition. Alkalinity results from the presence of bicarbonates, carbonates, hydroxides, volatile acids, salts, and occasionally borates, silicates and phosphate. Numerically it is expressed in terms of the concentration of calcium carbonate that would have equivalent capacity to neutralize strong acids.

**Bag House:** A dust collection system in which the dust is trapped when dust-laden air is passed through porous bags.

**Beneficiation:** Improvement of the chemical or physical properties of a raw material or intermediate products by removal of undesirable components or impurities.

**Blowdown:** A periodic discharge to prevent the buildup of dissolved solids due to evaporative loss in cooling towers and boilers.

**BOD (Biochemical Oxygen Demand) :** An indirect measure of the concentration of biologically degradable materials present in organic wastes. It is the amount of free oxygen utilized by aerobic organisms when allowed to attach the organic matter in any aerobically maintained environment at a specified temperature (20 C) for a specific time (5 days), It is expressed in milligrams of oxygen utilized per liter of liquid waste volume (mg/l) or in milligrams of oxygen per kilogram of solids present (mg/kg = ppm = parts per million parts).

**Burning:** Combustion of fuel, or sintering or near-fusion in a kiln, resulting in chemical combination of the raw materials and formation of clinker.

**Cement Cooler:** Equipment for cooling finished cement after grinding. May consist of a water-jacketed screw conveyor with a water-cooled impeller shaft and blades, or a vertical cylinder, with the outside cooled by running water and along the inner surface of which a thin layer of cement is moved by centrifugal action.

**Clarifier:** A large tank or pond used for holding turbid water for a sufficient time to allow solid materials to settle.

**Clinker:** The fused product of a kiln which is ground to make cement.

**COD (Chemical Oxygen Demand) :** An indirect measure of the biochemical load exerted on the oxygen assets of a body of water when organic wastes

are introduced into the water. It is determined by the amount of potassium dichromate consumed in a boiling mixture of chromic and sulfuric acids. The amount of oxidizable organic matter is proportional to the potassium dichromate consumed. Where the wastes contain only readily available organic bacterial food and no toxic matter, the COD values can be correlated with BOD values obtained from the same wastes.

Cooling Pond: A pond, sometimes equipped with sprayers, used with recycle cooling water systems to reduce the temperature of the water by evaporation.

Dissolved Solids: Solids dissolved in water and not removed by filtration.

Dry Process: Process for cement manufacture in which the raw materials are ground, blended, stored, and conveyed to the kiln in a dry form.

Effluent: The waste water discharged from a point source (plant).

Electrostatic Precipitator: Collector for fine dust, particularly in kiln gases. Dust laden air is passed through a large chamber where the dust particles are ionized by contact with chains or rods connected to one pole of a high-voltage rectifier, and then attracted to and collected on the sides of tubes or plates connected to the other (ground) pole. Collectors are rapped periodically to discharge dust.

Flocculation: Accumulation or agglomeration of fine particles into masses or flocs of suspended solids to facilitate settling.

Gas Analyzer: An instrument using the principle of chemical combination or catalytic combustion in which a sample of gas may be collected and analyzed for oxygen, carbon dioxide and combustible materials.

Insufflation: Practice of adding collected dust to the coal in a burner pipe for return to the kiln.

Kiln: A metal cylinder 2.5 to 8.5 in diameter and 65 to 250 m in length, slowly rotating (60 to 90 r.p.h.) and inclined approximately 4 cm per m toward its discharge end; for burning cement raw mix into clinker. Lined with refractory bricks and often equipped with internal heat exchangers.

Kiln Dust: Fine particles of cement and raw materials blown from the kiln and collected by air-pollution control equipment.

Leachate: The overflow discharged from a leaching operation.

Leaching: A process for removing alkalies from kiln dust by washing with water, so that the dust can be reused to make cement.

Loading: The quantity of a constituent added to the water used within a point source and subsequently discharged, normally expressed in amount per unit of production.

Outfall: A point at which the effluent from a point source is discharged into a navigable waterway.

Overflow: Excess water from an operation, tank, pond, etc. that is recycled or discharged, generally after settling of suspended solids.

pH: The symbol for the logarithm of the reciprocal of the hydrogen ion concentration, expressed in moles per liter of a solution, and used to indicate an acid or alkaline condition. (pH 7 indicates neutral; less than 7 is acid; greater than 7 is alkaline).

Portland Cement: The product obtained by pulverizing clinker consisting essentially of hydraulic calcium silicates, to which no additions have been made subsequent to calcination other than water and/or untreated calcium sulphate, except that additions not to exceed 1.0 percent of other materials may be interground with the clinker at the option of the manufacturer, provided such materials in the amounts indicated have been shown to be not harmful by tests carried out or reviewed by committee C1 on Cement of the American Society for Testing Materials (A.S.T.M.).

Process Water: A general term applied to the water used in operations directly related to the manufacture of a product, and sometimes contacting the products or raw materials, as distinguished from cooling water, boiler water, and all other water used in ancillary operations. In cement manufacturing the term is most commonly applied to the slurry water used at wet-process plants.

Pug Mill: A device for mixing water with cement dust to form a slurry.

RAPP Applications: Applications submitted to the U.S. Army Corps of Engineers to obtain a permit for discharge into navigable waters under the 1899 Refuse Act Permit Program.

Recycled Water: Water which is recirculated for the same use.

Reused Water: Water which is used for one purpose and then reused for another purpose.

Sedimentation: The removal of suspended solids contained in waste water that will separate by settling when the carrier liquid is held in a quiescent condition for a specified time interval.

Settling Basin: A pond, lagoon, or tank also referred to as holding or sedimentation basin in which suspended solids are removed sometimes by the addition of flocculants.

Sludge: The accumulated settled solids deposited from the sewage or other wastes, raw or treated, in tanks or basins, and containing sufficient water for form semiliquid mass.

Slurry: Suspension of ground raw materials in water.

Suspended Solids: Solids that either float on the surfact of, or are in suspension in, water and which are largely removable by filtering or sedimentation.

Thickener: Large basin for slurry of raw materials ground with excess water. Suspended particles settle to bottom (underflow), whereas surplus water (overflow) runs over edge.

Total Solids: The residue remaining when the water is evaporated from a sample of water, sewage, other liquids or semi-solids masses of material and the residue is then dried at a specified temperature (usually 103°C)

Underflow: Carrier water used in an operation to transport solids to another operation or disposal site.

Volatile Solids: That portion of the total or suspended solids residue which is driven off volatile (combustible) gases at a specified temperature and time (usually at 600 C for a leaste one hour).

Waste-Heat Boiler: System of boilers and economizers, heated by the hot exit gases from kilns, used to generate electricity.

Waste Load: The quantity of a constituent present in waste water expressed in units of concentration, amount per day, or amount per unit of production. Raw waste load is the quantity of a given constituent in the waste water prior to treatment. Net waste load is the difference between the quantity of a constituent in the intake and discharge waters.

Wet Process: Grinding, blending, mixing and pumping cement raw materials mixed with water. Wet process is chosen where raw materials have a high water content, which would make drying before crushing and grinding difficult.

Wet Scrubbber: Type of dust collector in which dust-laden gases are cleaned by passing through a fine spray of water.

METRIC UNITS  
CONVERSION TABLE 16

MULTIPLY (ENGLISH UNITS)		by	TO OBTAIN (METRIC UNITS)	
ENGLISH UNIT	ABBREVIATION	CONVERSION	ABBREVIATION	METRIC UNIT
acre	ac	0.405	ha	hectares
acre - feet	ac ft	1233.5	cu m	cubic meters
British Thermal Unit	BTU	0.252	kg cal	kilogram-calories
British Thermal Unit/pound	BTU/lb	0.555	kg cal/kg	kilogram calories/ kilogram
cubic feet/minute	cfm	0.028	cu m/min	cubic meters/minute
cubic feet/second	cfs	1.7	cu m/min	cubic meters/minute
cubic feet	cu ft	0.028	cu m	cubic meters
cubic feet	cu ft	28.32	l	liters
cubic inches	cu in	16.39	cu cm	cubic centimeters
degree Fahrenheit	°F	0.555 (°F-32)*	°C	degree Centigrade
feet	ft	0.3048	m	meters
gallon	gal	3.785	l	liters
gallon/minute	gpm	0.0631	l/sec	liters/second
horsepower	hp	0.7457	kw	kilowatts
inches	in	2.54	cm	centimeters
inches of mercury	in Hg	0.03342	atm	atmospheres
pounds	lb	0.454	kg	kilograms
million gallons/day	mgd	3,785	cu m/day	cubic meters/day
mile	mi	1.609	km	kilometer
pound/square inch (gauge)	psig	(0.06805 psig +1)*	atm	atmospheres (absolute)
square feet	sq ft	0.0929	sq m	square meters
square inches	sq in	6.452	sq cm	square centimeters
tons (short)	ton	0.907	kkg	metric tons (1000 kilograms)
yard	yd	0.9144	m	meters

\*Actual conversion, not a multiplier