

Quality Assurance Project Plan

for

Field Sampling Plan for Ambient Air Ethylene Oxide Monitoring Near Sterigenics Facility, Willowbrook, IL

U.S. Environmental Protection Agency

Office of Air and Radiation

Office of Air Quality Planning and Standards

and

EPA Region 5

EPA QA Category 1

Prepared by

EPA/OAQPS/AQAD

APPROVALS

LEWIS WEINSTOCK Digitally signed by LEWIS WEINSTOCK
Date: 2018.11.17 10:06:06 -05'00'

Lewis Weinstock, EPA OAQPS Project Manager

Xi Chen Digitally signed by Xi Chen
Date: 2018.11.17 22:00:31 -05'00'

Xi Chen, EPA OAQPS Monitoring Lead

JENIA MCBRIAN Digitally signed by JENIA MCBRIAN
Date: 2018.11.17 09:59:58 -05'00'

Jenia McBrian, EPA OAQPS QA Manager

Compher, Michael Digitally signed by Compher, Michael
Date: 2018.11.17 09:30:08 -06'00'

Michael Compher, EPA Region 5 Project Manager

JACQUELINE NWIA Digitally signed by JACQUELINE NWIA
Date: 2018.11.17 11:58:41 -06'00'

Jacqueline Nwia, EPA Region 5 Monitoring Lead

GREGORY NOAH Digitally signed by GREGORY NOAH
Date: 2018.11.17 20:00:32 -05'00'

Greg Noah, EPA OAQPS Field QA Coordinator

Table of Contents

<u>Section</u>	<u>Page</u>
1. PROJECT MANAGEMENT	7
1.1. Distribution List	7
1.2. Project Task/Organization	8
1.3. Problem Definition/Background	10
1.4. Project/Task Description and Schedule	11
1.5. Data Quality Objectives and Criteria for Measurement Data	13
1.5.1. The DQO Process	13
1.5.2. State the Problem	14
1.5.3. Identify the Decision	14
1.5.4. Identify the Inputs to the Decision	15
1.5.5. Define the Study Boundaries	16
1.5.6. Develop a Decision Rule	16
1.5.7. Specify Tolerable Limits on the Decision Errors	16
1.5.8. Optimize the Design for Obtaining Data	17
1.5.9. DQOs for this Study	17
1.6. Measurement Quality Objectives and Performance Criteria/Acceptance Criteria	18
1.7. Special Training Requirements/Certification	22
1.8. Documents and Records	22
1.9. QA Project Plan Distribution	24
1.10. Field Documentation and Records	24
1.11. Laboratory Documentation and Records	24

1.12. Final Reports.....	25
2. DATA GENERATION AND ACQUISITION	25
2.1. Sampling Design.....	25
2.1.1. Site Selection	25
2.1.2. Monitor Siting guidelines	32
2.2. Sampling Methods	32
2.3. Sample Handling and Custody.....	33
2.4. Analytical Methods.....	36
2.5. Field Measurements Methods.....	36
2.6. Field Analyses Methods.....	37
2.7. Laboratory Analyses Methods (ERG)	37
2.8. Quality Control Requirements	38
2.9. Field Sampling Quality Control.....	38
2.10. Field Measurement/Analysis Quality Control	38
2.10.1. Field Measurement QC.....	38
2.11. Laboratory Analysis Quality Control.....	39
2.12. Instrument/Equipment Testing, Inspection, and Maintenance	39
2.13. Field Measurement Instruments/Equipment.....	39
2.14. Laboratory Analysis Instruments/Equipment (ERG).....	41
2.15. Instrument/Equipment Calibration and Frequency.....	42
2.15.1. Field Measurement Instruments/Equipment.....	42
2.15.2. Laboratory Analysis Instruments/Equipment (ERG).....	42
2.16. Inspection/Acceptance Requirements for Supplies and Consumables	42

2.16.1. Field Sampling Supplies and Consumables.....	42
2.16.2. Laboratory Analyses Supplies and Consumables.....	43
2.17. Data Acquisition Requirements (Non-Direct Measurements).....	43
2.18. Data Management.....	43
3. ASSESSMENTS AND OVERSIGHT.....	45
3.1. Assessments/Oversight and Response Actions.....	45
3.1.1. Field and Laboratory Technical Systems Audits.....	45
3.1.2. Data Quality Assessments.....	48
3.2. Reports to Management.....	48
4. DATA REVIEW AND USABILITY.....	49
4.1. Data Review, Verification, and Validation Requirements.....	49
4.2. Verification and Validation Methods.....	50
4.3. Reconciliation with User Requirements.....	50
5. REFERENCES.....	51
6. APPENDICES.....	52

TABLES	Page
Table 1-1. Quality Control Requirements for Analyses.....	20
Table 1-2. Project Documents and Records	23
Table 2-1. Sampling Location Details and Rationale.....	26
Table 2-2. Modeled stack emissions and parameters.....	28

FIGURES	Page
Figure 1-1. Organization Chart.....	9
Figure 2-1. Site Map with Sampling Locations.....	27
Figure 2-2. Model Domain.....	29
Figure 2-3. 2013-2017 seasonal wind roses for Midway.....	30
Figure 2-4. Monitor locations and Scoring Results.....	31
Figure 2-5. ERG’s Sample Chain of Custody Form.....	35
Figure 2-6. ERG’s Sample Tracking Tag.....	36
Figure 2-7. Canister setup with Passive Vacuum Regulator.....	40
Figure 2-8. Canisters with tripod stand setup at Willowbrook Village Hall site.....	41
Figure 2-9. Data management and sample flow diagram.....	44
Figure 3-1. ERG’s corrective action report form.....	47

1. PROJECT MANAGEMENT

1.1. Distribution List

Name: Lewis Weinstock
Title: OAQPS Project Manager
Organization: EPA OAQPS
Email: Weinstock.Lewis@epa.gov
Phone:919-541-3661

Name: Xi Chen
Title: OAQPS Monitoring Lead
Organization: EPA OAQPS
Email: Chen.Xi@epa.gov
Phone:919-541-4957

Name: Jenia McBrian
Title: OAQPS QA Manager
Organization: EPA OAQPS
Email: McBrian.Jenia@epa.gov
Phone:919-541-0371

Name: Greg Noah
Title: OAQPS QA Field Coordinator
Organization: EPA OAQPS
Email: Noah.Greg@epa.gov
Phone:919-541-2771

Name: Michael Compher
Title: Region 5 Project Manager
Organization: EPA Region 5
Email: Compher.Michael@epa.gov
Phone:312-886-5745

Name: Jacqueline Nwia
Title: Region 5 Monitoring Lead
Organization: EPA Region 5
Email: Nwia. Jacqueline@epa.gov
Phone:312-886-6081

Name: James Thurman
Title: OAQPS Dispersion Modeler
Organization: EPA OAQPS
Email: Thurman.James@epa.gov
Phone:919-541-2703

Name: Julie Swift
Title: National Contract Laboratory Lead
Organization: Eastern Research Group
Email: Julie.Swift@erg.com
Phone:919-468-7924

1.2. Project Task/Organization

This project is managed and implemented by the Office of Air Quality Planning and Standards (OAQPS) Ambient Air Monitoring Group (AAMG) of the EPA Office of Air and Radiation (OAR). EPA Region 5 will conduct the sampling described in this QAPP, and sample analysis will be conducted by Eastern Research Group (ERG).

OAQPS Project Manager: Lewis Weinstock will have overall responsibility for the tasks included in this plan. These tasks include preparation of the Quality Assurance Project Plan (QAPP), serving as the point of contact with other members of the OAQPS team handling issues such as field sampling, laboratory analysis, stack testing and fugitives analysis at and around the source, coordination with the analytical laboratory (through the OAQPS monitoring lead), and coordination with public affairs staff. He will also track the project schedule and budget ensuring that activities remain on track and within budget. He will work closely with the Regional Project Lead to address and resolve any issues that occur with field sampling and/or other on the ground coordination activities.

OAQPS Monitoring Lead: Xi Chen will be the responsible for overseeing the overall project execution, as well as tasking contractors with work required to complete this project. She will communicate project needs to the contractors and coordinate laboratory services. She is responsible for the field monitoring sampling plan; coordinating sample collection and analysis; field sampling logistics; and be the point of contact to address any laboratory issues or concerns.

OAQPS QA Manager: Jenia McBrian will be responsible for reviewing and approving the QA Project Plan, performing audits of data quality (ADQ) and organizing required field and laboratory assessments. She may provide technical QA input on the proposed sampling design, analytical methodologies, and data review.

OAQPS Field QA Coordinator: Greg Noah will be responsible for performing the field TSA. The audit will consist of a thorough review of the field personnel implementing the standard operating procedures for this activity including: sample canister receipt and installation; sampler and site maintenance, quality control checks, log book and data entry (forms); sample chain of custody and sample shipment.

Region 5 Project Manager: Michael Compher will be responsible for assigning field sample operators their specific tasks and objectives.

Region 5 Monitoring Lead: Jacqueline Nwia will be responsible for communicating with the Regional Project Manager and field personnel. She will have overall responsibility for all field activities.

Contract Laboratory Lead: Julie Swift from the national contract laboratory Eastern Research Group (ERG), will be responsible for assigning appropriate laboratory staff to perform sample preparation and analyses specified in this plan and data reporting. She will also communicate technical issues; assist in the resolution of technical problems; review data completeness and data quality; and review all reports.

Contract Laboratory QA Manager: Donna Tedder from ERG will be responsible for ensuring quality of data generated in the contract laboratory. She will make QA recommendations; perform any internal laboratory audits; evaluate the effect of technical issues on data quality; and review 10% of all data reported.

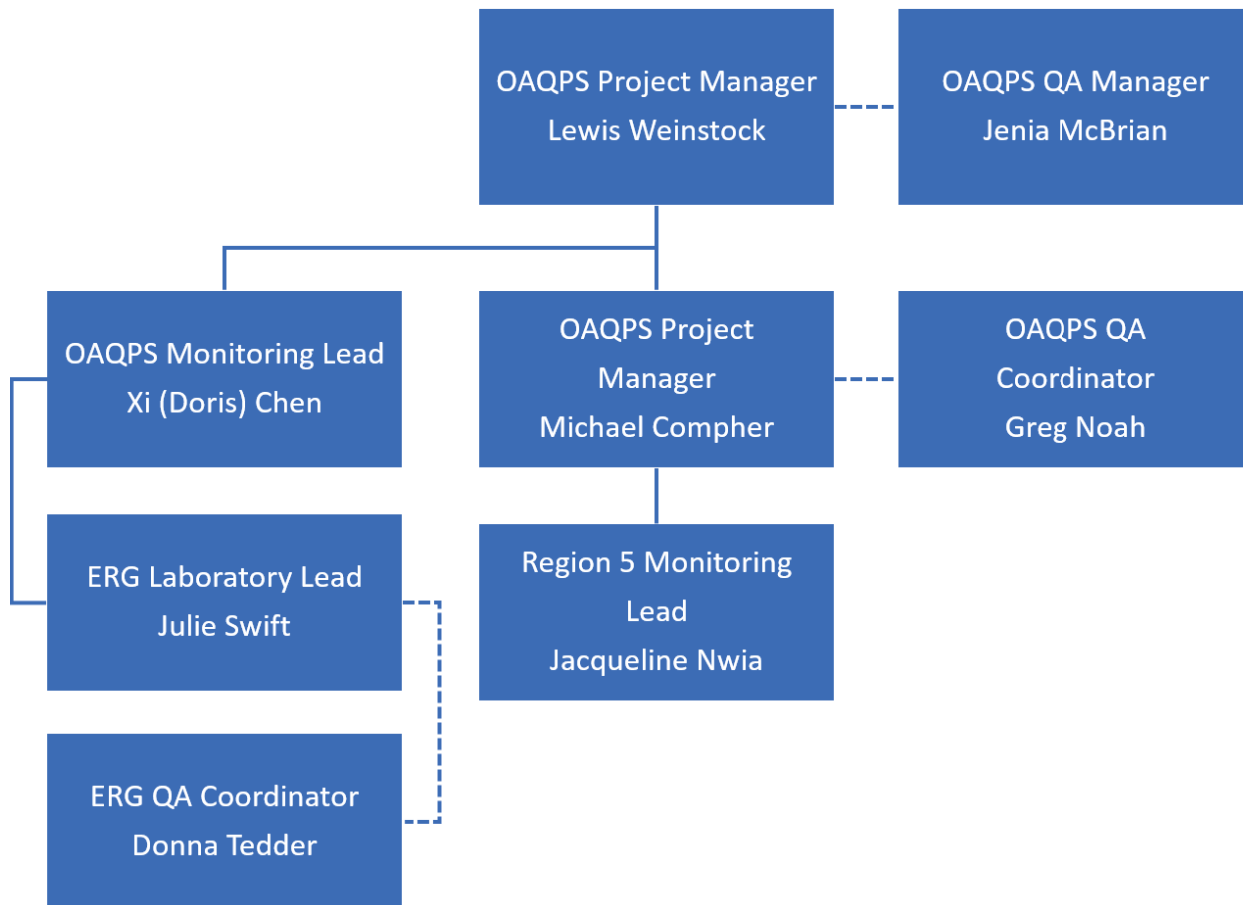

Figure 1-1. Organization Chart

1.3. Problem Definition/Background

In December 2016, EPA's Integrated Risk Information System (IRIS)¹ program released an updated assessment of the carcinogenicity of inhaled ethylene oxide (1). It concluded that ethylene oxide is "carcinogenic to humans" by the inhalation route of exposure. The updated cancer potency information (unit risk estimate (URE)) of ethylene oxide makes it about 60 times more potent, and more likely to induce cancer in humans than previously thought.

Updated approximately every three years, EPA recently (August 2018) completed the National Air Toxics Assessment² (NATA), using the 2014 national emission inventory (NEI)³, which provides estimates of the risk of cancer and other serious health effects from inhaling air contaminated with toxics from large and small industrial sources, from on- and off-road mobile sources, and from natural sources such as fires. NATA presents estimated risks at the census tract level. With the updated 2016 IRIS URE for ethylene oxide, NATA identifies 18 areas of the country that may have elevated long-term (chronic) cancer risks due to ethylene oxide emissions from stationary industrial sources. We define "elevated risk" as a risk equal to or greater than 100-in-1 million at a census tract. This means that for every million people who breathe elevated levels of ethylene oxide for 70 years, 100 people may get cancer because of that exposure. For ethylene oxide, the 2016 IRIS estimated 100-in-1 million risk level concentration is 0.011ppb (0.02 µg/m³).

The main use of ethylene oxide includes manufacture of ethylene glycol (antifreeze), solvents, detergents, adhesives and other products. Also, ethylene oxide is used as a fumigant and a sterilant for surgical equipment and plastic devices that can't be sterilized by steam (1). Chemical plants and sterilization facilities that use ethylene oxide may present health concerns due to uncontrolled emissions or venting to the atmosphere. Among the facilities identified as major source of ethylene oxide emissions, Sterigenics LLC in Willowbrook, IL had a reported emission rate of ~3 tons/year according to 2014 NEI. NATA census tract chronic risks for the Willowbrook, IL area range from 100-to 300-in-1

¹ https://cfpub.epa.gov/ncea/iris2/chemicalLanding.cfm?substance_nmbr=1025

² <https://www.epa.gov/national-air-toxics-assessment/2014-national-air-toxics-assessment>

³ <https://www.epa.gov/air-emissions-inventories/2014-national-emissions-inventory-nei-data>

million for 2014. In order to further assess and evaluate such elevated chronic cancer risk in the area, ambient monitoring will help better understand and ethylene oxide emission rates as well as concentration at breathable levels surrounding the identified facility. However, any monitoring technology has its limitations, such as its analytical limitation for the current available method (EPA Compendium Method TO-15(2)) that will be used for ethylene oxide. The estimated method detection limit (MDL) established for ethylene oxide by the ERG contract laboratory is 0.045 ppbv (0.08 $\mu\text{g}/\text{m}^3$), which translates to an around 400-in-1 million cancer risk. ERG estimated MDLs using the Method Update Rule (MUR)(3).

The established MDL will be met to evaluate the resulting data in a health-based context. The MDLs are generally set at or below the concentrations of individual air toxics for which a lifetime, continuous exposure would pose an excess lifetime cancer risk of one-in-one million or a hazard quotient of 0.1. However, for ethylene oxide the laboratory analytical methodology is insufficient to achieve such an MDL. Because the level of the MDL substantially limits our interpretation with regard to about potential significance of health risk-related impacts at 100-in-1 million, this will be recognized in reporting and interpreting the results.

1.4. Project/Task Description and Schedule

The ambient air monitoring efforts are intended to characterize ambient concentrations of ethylene oxide around the Sterigenics Willowbrook, IL facility to inform the following issues:

- a. Determine the maximum and longer-term concentration(s) in proximity to the facility;
- b. Explore the relationship of ambient concentrations to facility operations (vents/fugitive) and ethylene oxide usage;
- c. Characterize concentrations in potentially affected nearby neighborhoods to the extent possible based on method sensitivity.

This project will follow EPA Compendium Method TO-15, "Determination of Volatile Organic Compounds (VOCs) in Air Collected in Specially Prepared Canisters and Analyzed by Gas Chromatography/Mass Spectrometry (GC/MS) for both sampling and analysis methodology."

A total of eight fixed sampling locations will be selected based on the EPA's latest dispersion

modeling of the two Sterigenics buildings, community input and representative seasonal wind data. The locations will include:

- a. Two locations at the maximum ambient air receptors in close proximity to the facility;
- b. Three locations in residential neighborhoods potentially impacted by the perimeter of the dispersion modeling field and/or located in the predominant downwind direction during the monitoring period;
- c. Three locations in residential neighborhoods as selected by the communities (these locations are outside the dispersion modeling field where impact is expected).

The Region 5 office will conduct ethylene oxide ambient air sampling on a 1-in-3 schedule (once every third day), based on the national sampling calendar (Appendix A).

Sampling will begin at sampling locations 1 and 2 (see table 2-1 and Figure 2-1) on Tuesday, November 13, 2018. The remaining six sites will be deployed on Monday November 19, 2018. The only exceptions to the national sampling calendar are the following: November 22, 2018 deployment will be moved to November 23, 2018; December 25, 2018 deployment will be moved to December 26, 2018; and January 21, 2019 deployment will be moved to January 22, 2019.

Unless otherwise noted, each sampling event will begin approximately at 10:00 Local Standard Time (LST) and end at 10:00 LST the next day for a 24 hr duration. However, considering the potential logistical delays for collecting samples, a 24 ± 1 hr duration is required. The base (i.e., minimum duration) sampling period is 90 days. Given the 1-in-3 day sampling schedule for a period of 90 days and a 85% sampling completeness criteria, the base sampling period is intended to result in no less than 26 valid samples. There may be cases in which EPA shall deem the 90-day sampling period insufficient (e.g., invalidated sample(s), insufficiently representative data, etc.) and extend sampling for a sufficient period to achieve the goal of 26 valid samples.

It will take approximately two three weeks for EPA to determine whether the last samples are valid. Missed or invalidated samples will only be made up on the established site-specific 1-in-3 day schedule (i.e., extend the base 90 day sampling period to include the required number of makeup samples to achieve a minimum of 26 valid samples).

Sampling will cease upon collection of the 30th regularly scheduled (i.e., 1-in-3 day) sample,

with the following exception: If EPA deems any of the samples invalid as a result of problems during sample collection or laboratory analysis, sampling will be extended for as many samples as needed to collect 26 valid samples.

1.5. Data Quality Objectives and Criteria for Measurement Data

The primary objective for this project is to collect information on ambient air concentrations of ethylene oxide at a selected list of sites in and adjacent to Willowbrook, IL during a defined monitoring period. This monitoring information will be used to:

1. Help characterize fugitive emissions from the Sterigenics Willowbrook facility;
2. Better understand potential concentrations in Willowbrook and surrounding communities, considering the limitations of the TO-15 method for this chemical; and
3. Assist us in identifying locations where additional information, including additional monitoring, may be needed to better understand potential concentrations in Willowbrook and surrounding communities, considering the limitations of the TO-15 method for this chemical.

To do this work, EPA OAQPS along with its Region 5 partners, will facilitate the collection of ambient air data at the identified sites. The focus will be on assessing impacts associated with the nearby Sterigenics facility and will provide information to residents that live nearby the sites about potential air toxics concerns from the facility.

The DQO process described in EPA's QA/G-4 (<https://www.epa.gov/sites/production/files/2015-06/documents/g4-final.pdf>) document provides a general framework for ensuring that the data collected by EPA or any Environmental Data Operation (EDO) meets the needs of the intended decision makers and data users. The process establishes the link between the specific end use(s) of the data with the data collection process and the data quality (and quantity) needed to meet a program's goals. The following sections provide the required information for the DQO process.

1.5.1. The DQO Process

This section presents an overview of the seven steps in EPA's QA/G-4 DQO process as applied to the objectives of this project. The purpose of this section is to provide a general discussion of the specific issues that were used in developing the DQOs for this project.

The DQO process is a seven-step process based on the scientific method to ensure that the data collected by EPA meet the needs of its data users and decision makers in terms of the information to be collected and, in particular, the desired quality and quantity of data. It also provides a framework for checking and evaluating the program goals to make sure they are feasible, and that the data are collected efficiently. The seven steps are usually labeled as:

1. State the Problem
2. Identify the Decision
3. Identify the Inputs to the Decision
4. Define the Study Boundaries
5. Develop a Decision Rule
6. Specify Tolerable Limits on the Decision Errors
7. Optimize the Design for Obtaining Data Each of these elements is discussed in detail below.

The pollutant specific outcomes of the DQO process are contained in Section 1.7.1.8.

1.5.2. State the Problem

The EPA project team developed the following problem statement:

Information about the updated assessment of the carcinogenicity of inhaled ethylene oxide from EPA's IRIS Program has raised questions about outdoor air quality around some sites near the Sterigenics LLC facility in Willowbrook, IL. Measuring the levels of ethylene oxide in the air around these sites will help EPA better understand potential concentrations.

EPA will use what it learns from this monitoring initiative to determine its next steps.

1.5.3. Identify the Decision

The decision statement should provide a link between the principal study question and possible actions. The decision that the monitoring at these sites is intended to inform is as follows:

Data will be collected from selected sites based on EPA's latest dispersion modeling for the two Sterigenics buildings, community input, and representative seasonal wind direction data (see Section

2.1.1). Monitoring will be performed in such a way that the resulting data will be sufficient in terms of quantity and quality to better inform our understanding of ethylene oxide concentrations in the ambient air at these sites. These data along will be relied upon by EPA to:

1. Help characterize fugitive emissions from the Sterigenics Willowbrook facility;
2. Better understand potential concentrations in Willowbrook and surrounding communities, considering the limitations of the TO-15 method for this chemical; and
3. Assist us in identifying locations where additional information, including additional monitoring, may be needed to better understand potential concentrations in Willowbrook and surrounding communities, considering the limitations of the TO-15 method for this chemical.

1.5.4. Identify the Inputs to the Decision

This section discusses the variety of inputs that are needed to make the final DQO decision for this program. In addition to the monitoring results, other inputs potentially important to decision-making for this project include, but are not limited to, the following items (not listed in any priority order):

1. List of target sampling sites;
2. Existing ambient air sampling methods and analytical techniques;
3. NATA estimates;
4. Source-specific emission inventory information;
5. Existing ambient monitoring data;
6. Nearby meteorological monitoring data from the EPA Region 5, the National Weather Service and/or local airport weather data;
7. Topographical information pertaining to factors influencing pollutant transport;
8. Health effects information, including dose-response values and information available on the OAQPS and ATSDR web sites;
9. Community concerns;
10. Historical monitoring, modeling, health assessments, and other information (e.g., compliance status, voluntary emissions reduction programs, etc.) for the area; and,
11. Funding Information.

1.5.5. Define the Study Boundaries

The specific location of the monitors will be established to represent ambient air in the proximity of the facility, as described in this QAPP. Siting criteria that are detailed in Code of Federal Regulations (CFR) Chapter 40 Section 58, Appendix E2 will be followed to the extent that is practical, as described in this Plan. Any deviations from the siting criteria will be identified and documented in the final report. Some monitors will be located in Willowbrook, IL, and others will be located in the adjacent communities of Burr Ridge, IL and Darien, IL

1.5.6. Develop a Decision Rule

The decision rule is an “if ... then” statement for how the various alternatives will be chosen.

If the available monitoring data and other information are insufficient to support a conclusion, then additional data collection may be pursued. If the available monitoring data and other information are sufficient to reach a conclusion regarding the need for further action and do not support the conclusion that further action is needed, then additional data collection will not be pursued.

1.5.7. Specify Tolerable Limits on the Decision Errors

Budgetary constraints are a consideration in describing the DQOs. The program has a finite budget that affects the amount of monitoring performed in this program. The initial monitoring will include samples collected from eight sites on a 1-in-3 day schedule over a three-month period. It was decided that on-site measurements will include meteorological data such as wind direction and wind speed to help inform our consideration of this issue. The monitoring data set will need to include samples taken when the predominant wind direction is generally from the sources in question in order to fully support the decision making process contemplated in this exercise.

In order to understand other aspects of the quality of the data (i.e., precision and bias) the precision estimates of the analytical method were based on the estimates from EPA’s contract laboratory (ERG) and other method estimates and is expressed in terms of coefficient of variance (CV).

The bias was chosen from the analytical method (EPA Compendium TO-15). Data from canister batch and trip blanks will be used to monitor method bias, which has an acceptance criteria of $<3x$ the method MDL.

Data completeness will be set at $\geq 85\%$ (a minimum of 26 valid samples collected over a 90 day period). If, due to unforeseen events, 26 valid samples are not collected in 90 days, monitoring will continue until 26 samples are collected. Thus, $\geq 85\%$ completeness will be achieved.

The estimated method detection limits (MDLs) will be met to evaluate the resulting data in a health-based context. We define “elevated risk” as a risk equal to or greater than 100-in-1 million at a census tract. This means that for every million people who breathe elevated levels of ethylene oxide for 70 years, 100 people may get cancer because of that exposure. Because the level of the MDL substantially limits our interpretation about potential significance of health risk-related impacts, this will be recognized in reporting and interpreting the results.

1.5.8. Optimize the Design for Obtaining Data

The team decided sampling will follow a “one every three days” schedule. A program goal of $\geq 85\%$ data completeness is established for the initial monitoring (90 days) since this is a short-term program and the number of samples initially collected will be small. However, if the wind does not come from the direction of the sources of interest impacting the sites, then the need for additional monitoring may be indicated to evaluate the significance of source contributions.

1.5.9. DQOs for this Study

This section combines all the information gathered and states the action that will be followed given the scenarios that can occur.

To better evaluate potential impacts of ethylene oxide in the vicinity of the Sterigenics facility in Willowbrook, IL, monitoring will commence at selected locations. If the following criteria are met, the data will be considered of sufficient quantity and quality for the decision-making to commence as described in section 1.7.1.2:

1. Data are collected with a coefficient of variance (precision) and bias as stated in Table 1-1;
2. Data completeness is $\geq 85\%$ or 26 samples within a window of 90 days;

3. MDLs are at or below those specified in Table 1-1 and;
4. Where applicable, sufficient samples are collected when the predominant wind direction is from the source in question.

1.6. Measurement Quality Objectives and Performance Criteria/Acceptance Criteria

Once a DQO is established, the quality of the data must be evaluated and controlled to ensure that it is maintained within the established acceptance criteria. Measurement Quality Objectives (MQOs) are designed to evaluate and control various phases (i.e., sampling, preparation, and analysis) of the measurement process to ensure that total measurement uncertainty is within the range prescribed by the DQOs. The National Air Toxics Trends Station (NATTS) Technical Assistance Document (TAD) (4) (see Appendix D) presents the requirements for collecting and reporting data for the NATTS network. MQOs can be defined in terms of the following data quality indicators (DQIs):

Precision - a measure of mutual agreement between individual measurements performed according to identical protocols and procedures. This is the random component of error.

Analytical precision is calculated by comparing the differences between Replicate analyses (two analyses of the same sample) from the arithmetic mean of the two results as shown below. Replicate analyses with low variability have a lower Relative Percent Difference (RPD) (better precision), whereas high variability samples have a higher RPD (poorer precision).

$$RPD = \frac{|X_1 - X_2|}{\bar{X}} \times 100$$

Where:

X_1 = Ambient air concentration of a given compound measured in one sample;

X_2 = Concentration of the same compound measured during replicate analysis;

\bar{X} = Arithmetic mean of X_1 and X_2 .

Method precision is calculated by comparing the concentrations of the duplicates/collocates for each pollutant. The Coefficient of Variation (CV) calculation shown below is ideal when comparing paired values, such as a primary concentration versus a duplicate concentration.

$$CV = \sqrt{\frac{\sum_{i=1}^n \left[\frac{p - r}{0.5 \times (p + r)} \right]^2}{2n}} \times 100$$

Where:

p = the primary result from a duplicate or collocated pair;

r = the secondary result from a duplicate or collocated pair;

n = the number of valid data pairs.

Bias - the systematic or persistent distortion of a measurement process that causes error in one direction. Bias is determined by estimating the positive and negative deviation from the true value as a percentage of the true value.

Sensitivity - the determination of the low range critical value of a characteristic that a method-specific procedure can reliably discern (also referred to as detectability).

Completeness - a measure of the amount of valid data obtained from a measurement system compared to the amount that was expected to be obtained under correct, normal conditions.

In theory, if these MQOs are met, measurement uncertainty should be controlled to the levels required by the DQO. Table 1-1 lists the MQOs for ethylene oxide that will be measured for this program. More detailed descriptions of these MQOs and how they will be used to control and assess measurement uncertainty will be described in this QAPP. Data within these tables reflect the MQOs needed to meet the DQOs for this program.

See Table 1-1. Quality Control Requirements for Analyses and Acceptance criteria/measurement performance criteria for each DQI.

Table 1-1. Quality Control Requirements for EPA Compendium Method TO-15

QC Sample:	DQI	Frequency	Acceptance Criteria	Corrective Action
CV (collocated sample)	Precision	1/sample event	≤25%	Flag the data
RPD (replicate samples)	Precision	1/sample event	≤25%	Flag the data
Valid sample numbers	Completeness	N/A	No less than 26 ≥85%	Collect make up samples
Canister batch blank	Bias	2 batches*/week	<3x MDL	Canisters put through an additional vacuum and pressure cleaning cycle
Canister trip blank	Bias	2/month	<3x MDL	Flag the data
MDL	Sensitivity	1/method modification	≤0.045 ppb or 0.082 µg/m ³	Identify sources of problem, eg. thoroughly clean the system
BFB instrument tune performance check	Lab QC	Daily ^b , prior to sample analysis	Evaluation criteria presented in Table 11-3 of ERG QAPP	1) Retune 2) Clean ion source and/or quadrupole
Initial calibration (ICAL) consisting of at least 5 points bracketing the expected sample concentration	Lab QC	Following any major change, repair or maintenance or if daily QC is not acceptable. Recalibration not to exceed three months.	1) RSD of response factor <± 30%, with two exceptions of up to ± 40% for non-tier I compounds only 2) Internal Standard (IS) response ±40% of mean curve IS response 3) Relative Retention Times (RRTs) for target peaks ±0.06 units from mean RRT 4) IS RTs within 20 seconds of mean 5) Each calibration standard concentration must be within ± 30% of nominal (for Tier I compounds)	1) Repeat individual sample analysis 2) Repeat linearity check 3) Prepare new calibration standards and repeat analysis
LCS ({ICV} Initial/Second source calibration verification check)	Lab QC	Following the Calibration curve	The response factor ≤ ±30% Deviation from calibration curve average response factor	1) Repeat calibration check 2) Repeat calibration curve
Continuing Calibration Verification (CCV) of approximately	Lab QC	Before sample analysis on the days of sample analysis ^b	The response factor ≤ ±30% deviation from calibration curve average response factor	1) Repeat calibration check 2) Repeat calibration

QC Sample:	DQI	Frequency	Acceptance Criteria	Corrective Action
mid-point of the calibration curve ^a using a certified standard				curve
Method Blank (MB) analysis (zero air or N ₂ sample check)	Lab QC	Daily ^b , following BFB and calibration check; prior to sample analysis	1) <3x MDL or 0.2 ppbv whichever is lower 2) IS area response \pm 40% and IS RT \pm 0.33 min. of most recent ICAL	1) Repeat analysis with new blank canister 2) Check system for leaks, contamination 3) Reanalyze blank
Canister cleaning certification	Lab QC	One canister analyzed on the air toxics system per batch of 8	< 3x MDL or 0.2 ppbv whichever is lower	Reclean canisters and reanalyze
Preconcentrator leak check	Lab QC	Each standard and sample canister connected to the preconcentrator/ autosampler	\leq 0.2 psi change/minute	1) Retighten and re-perform leak check 2) Provide maintenance 3) Re-perform leak check test
Sampler certification standard challenge with a reference can and a zero check with a reference can	Lab QC	Annual	Challenge: Within 15% of the concentration in the reference canister. Zero: up to 0.2 ppbV or 3x MDL (whichever is lower) higher than the reference can	1) Repeat certification of samplers, a requirement for Tier I compounds 2) Notify Program Manager (flagging non-Tier I compound data for sampler may be an option)
Sampling period	Field QC	All samples	24 hours \pm 1 hours	1) Notify Program Manager 2) Flag samples with a "Y" flag 3) Invalidate and resample for > 24 \pm 1 hours
Retention Time (RT)	Lab QC	All qualitatively identified compounds	RT within \pm 0.06 RRT units of most recent initial calibration average RT	Repeat analysis
Samples – Internal Standards	Lab QC	All samples	IS area response within \pm 40% and IS RT within \pm 0.33 min. of most recent calibration	Repeat analysis

*The maximum capacity of one batch of samples to be cleaned is 12.

^a The same QA criteria are needed for SNMOC and PAMS analysis.

^b Every 24 hours frequency.

1.7. Special Training Requirements/Certification

Field support staff from U.S. EPA Region 5 are trained and experienced on collecting the samples, chain of custody procedures as well as process for shipping the canisters to Eastern Research Group (ERG). No additional training is required as Region 5 field staff abide by Section 5.0 Personnel Qualifications/Responsibilities of the Region 5 Standard Operating Procedure for the Collection of VOC Samples (R5-ARD-0003-r2). ERG's "Sampling Procedures for Passive Vacuum Regulators" (see Appendix B) will be followed to collect samples. The procedure is designed for sampling volatile organic compounds (VOCs) in ambient air, based on the collection of whole air samples in SUMMA® treated canisters to final pressures below atmospheric.

Experienced and trained EPA contractors will perform all necessary sample preparation and sample analysis procedures. Each scientist participating in this project has demonstrated proficiency with the specific analytical procedures tasked, and the EPA contracted laboratory is to maintain records of all training and documented analyst proficiency (see Appendix C for ERG's QAPP).

1.8. Documents and Records

Documents and records generated for this project include the QA project plan, field and laboratory records, email correspondence, assessment reports, as well as a project final report. Table 1-2 represents the documents and records, at a minimum, that must be filed. These documents, including draft and intermediate versions of significant importance to the project records will be stored and maintained consistent with EPA records management policies. In general, all the information listed in Table 1-2 will be retained for 5 years. However, if any litigation, claim, negotiation, audit or other action involving the records has been started before the expiration of the 5-year period, the records will be retained until completion of the action.

Table 1-2. Project Documents and Records

Categories	Record/Document Types	Responsible Party
Site Information	<ul style="list-style-type: none"> • Network description • Site characterization file • Site maps • Site Pictures 	EPA Region 5
Field Operations Information	<ul style="list-style-type: none"> • QA Project Plan • Standard operating procedures (SOPs) • Field and laboratory notebooks • Sample handling/custody records • Inspection/Maintenance records 	EPA OAQPS, Laboratory Contractor (ERG), EPA Region 5
Laboratory Data and Operations Information	<ul style="list-style-type: none"> • Any original data (routine and QC data) including data entry forms • Electronic deliverables of summary analytical and associated QC and calibration runs per instrument • Control charts • Chromatograms and spreadsheets with raw unadjusted data • SOPs 	Laboratory Contractor (ERG)
Quality Assurance Information	<ul style="list-style-type: none"> • Network siting and reviews • Data quality assessments • QA reports • Technical System Audits • Response/Corrective action reports • QA Final Report 	EPA OAQPS, Laboratory Contractor (ERG), EPA Region 5
Other Information	<ul style="list-style-type: none"> • Final Report • Email correspondence 	EPA OAQPS, Region 5, ERG Laboratory Contractor (ERG)

1.9. QA Project Plan Distribution

The project manager will be responsible for ensuring that the QAPP and any revisions will be circulated to appropriate project participants. The final approved QAPP will be uploaded to the U.S. EPA's website created for this project (<https://www.epa.gov/il/sterigenics-willowbrook-facility>).

1.10. Field Documentation and Records

Each canister sample collected will be assigned a unique sample number with a sample tag. A chain-of-custody (COC) form will be provided for each sample. The date and time sample collection started and ended, initial and final pressure gauge readings, and site locations will be documented and recorded on the COC form. COC forms will be scanned and saved as records on ERG's Laboratory Information Management System (LIMS).

Field staff will maintain log books to document sampling activities and any unusual events that may impact results. Log books will be reviewed during technical systems audits and filed with the OAQPS Monitoring Lead at the end of the project.

All field SOPs used in this program are included in the Appendix and will be filed with the OAQPS Monitoring Lead.

1.11. Laboratory Documentation and Records

The laboratory contractor, ERG, has a structured records management system that allows for the efficient archive and retrieval of records. Each laboratory archives the data from computer systems onto a shared network drive. The paper copies of all analyses are stored on site in a secured temperature-controlled area for up to five years. All raw data required for the calculation of concentrations and QA/QC data are collected electronically or on paper data forms. Raw data collected will be stored in LIMS, which is equipped with an automatic digital tape backup system. Backup of the LIMS is performed daily, weekly, and biannually. Refer to ERG's QAPP, "SUPPORT FOR THE EPA NATIONAL MONITORING PROGRAMS," (ERG-QAPP-0344-4) section 6 in Appendix C).

All laboratory SOPs used in this program will be filed with the OAQPS Monitoring Lead. Some of these procedures have been deemed as Confidential Business Information (CBI) but are available to EPA personnel.

1.12. Final Reports

The project managers and contract laboratory will compile the final report to summarize the details of the sampling performed, the concentration results, as well as any data analysis conducted. The report will contain the following information:

- a. Names of participating sites and corresponding metadata information;
- b. Description of the sampling and analytical methodologies used by the laboratory;
- c. Completeness of the monitoring effort for each site;
- d. Background information on the methodology used to present and analyze the data;
- e. General combined and individual site summary of the results;
- f. Variability analysis (intra-site comparisons);
- g. Pollution roses to determine predominant direction;
- h. Discussion of precision and accuracy and other QC information; and
- i. Discussions of conclusions and recommendations.

2. DATA GENERATION AND ACQUISITION

2.1. Sampling Design

2.1.1. Site Selection

A total of eight fixed sampling locations were selected based on the EPA's latest dispersion modeling (see below for details)⁴ for the two Sterigenics buildings, community input, and representative seasonal wind direction data⁵. However, if the wind does not come from the direction of the sources of interest impacting the sites, then the need for additional monitoring and changes to site locations may be indicated to evaluate the significance of source contributions. The initial sampling locations will include:

- a. Two locations at the maximum ambient air receptors in close proximity to the facility;

⁴ Conducted by EPA/OAQPS, utilizing results from Sept 2018 source test

⁵ Locations based on November – April wind rose data from Midway airport

- b. Three locations in residential neighborhoods potentially impacted by the perimeter of the dispersion modeling field and/or located in the predominant downwind direction during the monitoring period; and
- c. Three locations in residential neighborhoods as selected by the communities (these locations are outside the dispersion modeling field where impact is expected).

Table 2-1 provides the list of sampling locations with latitude/longitude and rationale for site selection.

Table 2-1. Sampling Location Details and Rationale				
#	Sampling Location	Latitude	Longitude	Rationale for Sampling Design
1	Willowbrook Village Hall	41.748589	-87.941090	Maximum Commercial #1
2	EPA Willowbrook Warehouse	41.747438	-87.938739	Maximum Commercial #2
3	Gower Middle School	41.743462	-87.933924	Residential Impact
4	West Neighborhood	41.748763	-87.94556	Residential Impact
5	Water Tower	41.755363	-87.939163	Residential Impact
6	Willow Pond Park	41.763981	-87.939845	Residential-community request
7	Hinsdale South High School	41.753685	-87.948497	Residential-community request
8	Gower Elementary School	41.748835	-87.956179	Community request
9 ^a	Eisenhower Junior High School	41.753003	-87.978947	Community request

^a Sampling tripods have been installed at all 9 locations listed but, at least initially, monitoring will occur at the first 8 sites.

Figure 2-1 provides a map with the sampling locations.

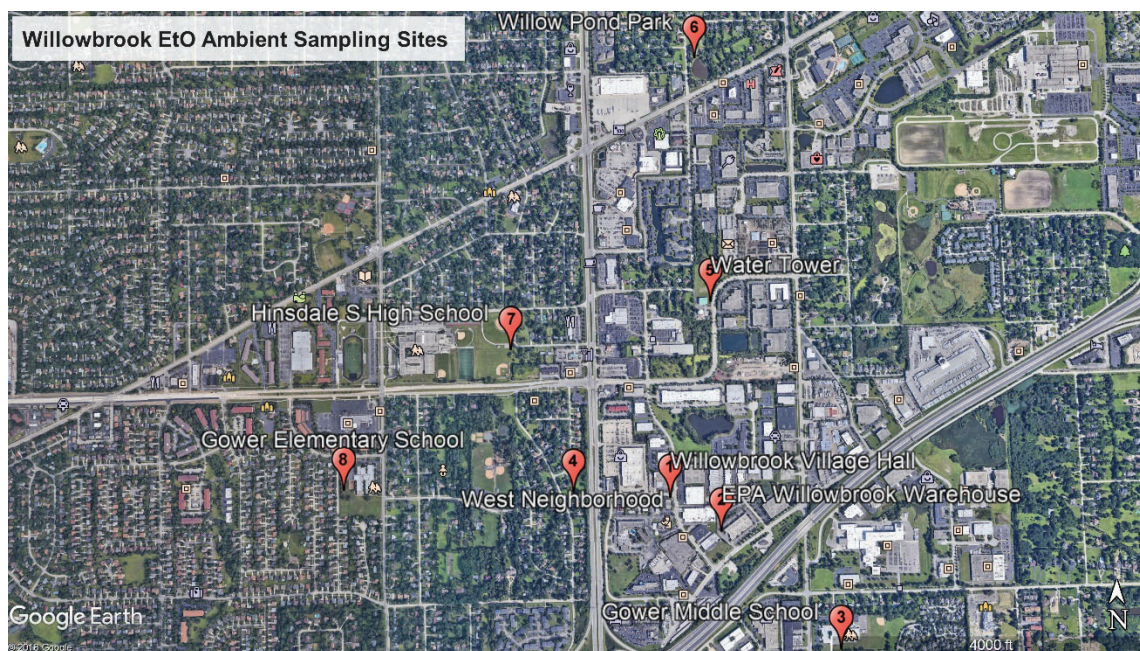

Figure 2-1. Site Map with Sampling Locations

Air dispersion modeling of Sterigenics was conducted using the latest version of EPA's atmospheric dispersion model, the AERMOD modeling system (version 18081), to inform monitor placement. Information about AERMOD formulation and performance evaluation can be found in the AERMOD Model Formulation and Evaluation document (EPA-454/R-18-003). Emissions input to the model were based on stack test results from September 2018 and emissions were modeled with the most recent 5 years of complete meteorological data, 2013 through 2017, using Midway International Airport for the surface meteorological data⁶ and Davenport, IA for upper air data⁷. Midway is located approximately 15 km east of Sterigenics and judged adequately representative of the facility based on guidance in Section 8.4.1 the Guideline on Air Quality Modeling. Davenport was also judged to be representative of upper air conditions over Sterigenics. Standard hourly wind observations from Midway were supplemented with hourly average winds calculated from 1-minute winds using the AERMINUTE

⁶ Integrated Surface Hourly Data (ISHD) downloaded from <ftp.ncdc.noaa.gov>

⁷ Downloaded from <https://ruc.noaa.gov/raobs/>

processor (version 15272). Stack locations and parameters, building parameters for downwash, and the 2-km by 2-km receptor grid (758 receptors) with elevations were supplied by Sterigenics and no issues were found with the source characterizations (as vertical or horizontal stacks), stack parameters and locations. Stack parameters were modified based on the September stack tests. See Table 2-2 for stack emissions and parameters. The receptor domain is below with the Sterigenics facility denoted by the green squares.

Table 2-2. Modeled stack emissions and parameters

AERMOD ID	Source type	Emissions (g/s)	Stack height (m)	Stack temperature (K)	Exit velocity (m/s)	Stack diameter (m)
STK1	POINT	3.88E-04	8.5344	308.15	18.00707	0.1524
STK2	POINT	5.95E-04	9.7536	314.8167	18.35958	0.6096
STK4	POINT	3.68E-03	10.255	301.4833	10.18919	0.6858
STK5	POINT	1.23E-03	10.3124	301.4833	1.458640	1.3716
STK6	POINT	1.23E-03	9.5504	300.9278	1.533169	1.3716
A	POINT	2.20E-03	9.7536	312.0389	12.67323	0.70104
P	POINT	6.03E-04	10.2362	300.9278	5.409891	0.955528
Q	POINT	1.21E-03	10.2362	300.9278	10.96896	0.955528
T2	POINTHOR	6.03E-04	0.9779	297.5944	4.847607	1.318398
T3	POINTHOR	6.03E-04	0.9779	297.5944	11.22017	1.318398

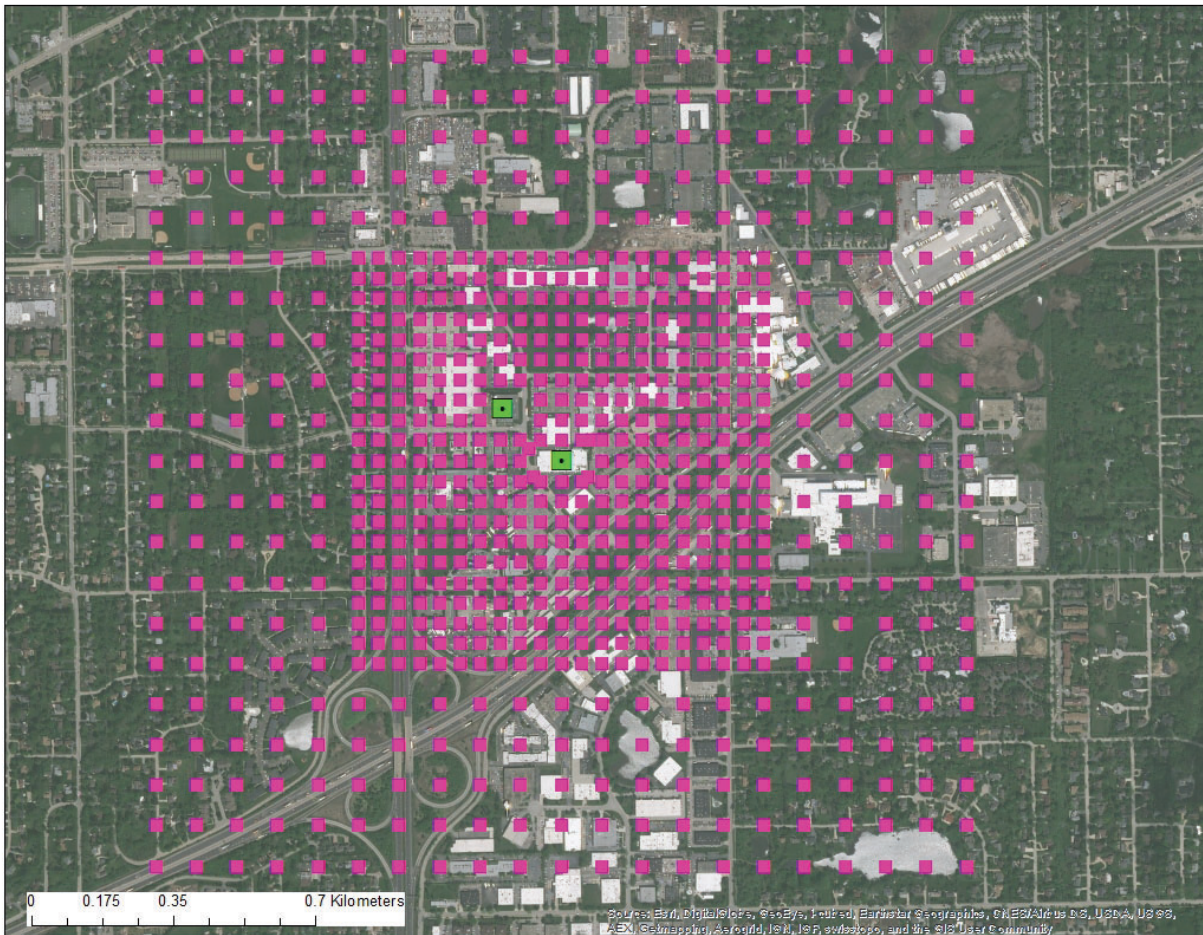

Figure 2-2. Model Domain

Key metrics output from the model or calculated from model output to inform monitor placement were:

- a. Maximum 24-hour concentration by receptor across the period of 2013-2017;
- b. 5-year seasonal averages by receptor;
- c. 5-year average by receptor.

Maximum 24-hour concentrations were considered because the monitoring would take place at 24-hour intervals. Seasonal averages were considered because the wind roses by season, exhibited seasonal differences (Figure 2-3), especially winter, and long-term averages were chosen to be

consistent with the annual results of NATA. AERMOD did not directly output seasonal averages. Monthly concentrations were output from AERMOD and seasonal averages were calculated from the monthly averages, consistent with AERMOD's internal averaging for long term averages, i.e. including only hours that were not calm or missing in the model output.

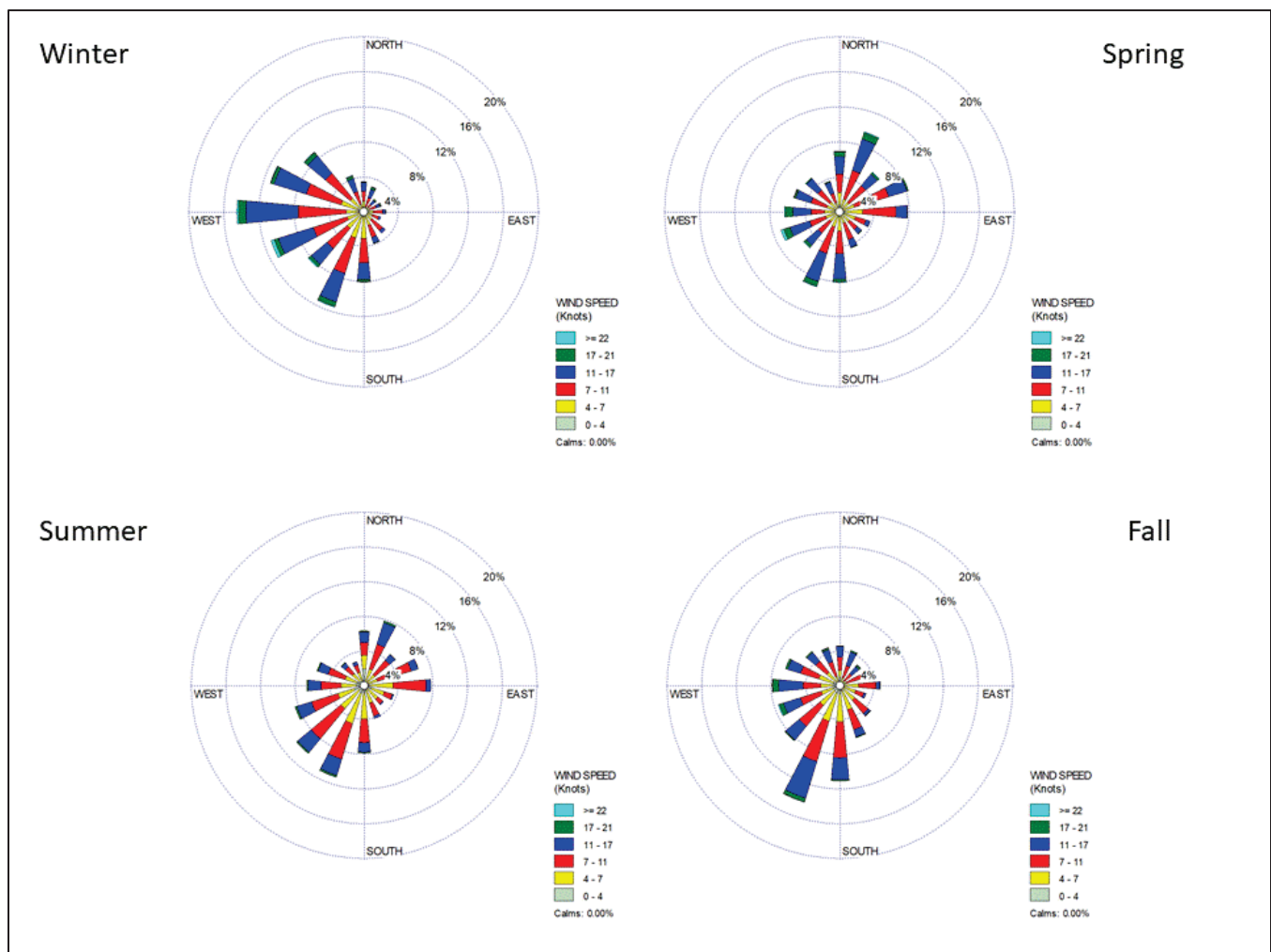

Figure 2-3. 2013-2017 seasonal wind roses for Midway.

To inform the monitor siting, a scoring system was developed by ranking metrics (the maximum 24-hour concentrations across all receptors, ranking each 5-year average season's concentration by receptor, and ranking the 5-year average concentration by receptor), with a receptor receiving a rank of =1 if it had the maximum concentration for the averaging time. This resulted in six rankings for each

receptor (24-hour, winter, spring, summer, fall, and 5-year average). The score was calculated for each receptor by adding together its rank for each averaging time (the 24-hour ranking, each season's rank, and the 5-year average rank of each receptor). For example, a receptor that has the highest 24-hour average concentration, the highest winter, spring, summer, and fall average concentrations, and highest 5-year average concentration would have a score of 6 (1+1+1+1+1+1). The lower the score, the higher the probability an area will see higher concentrations from the facility for one or more of the averaging periods, making it more conducive for a potential monitor location. The results of the scoring, along with the monitor locations, excluding the upwind monitor, are shown below. The monitors' locations coincide with local minima (higher concentrations) of the receptor scores.

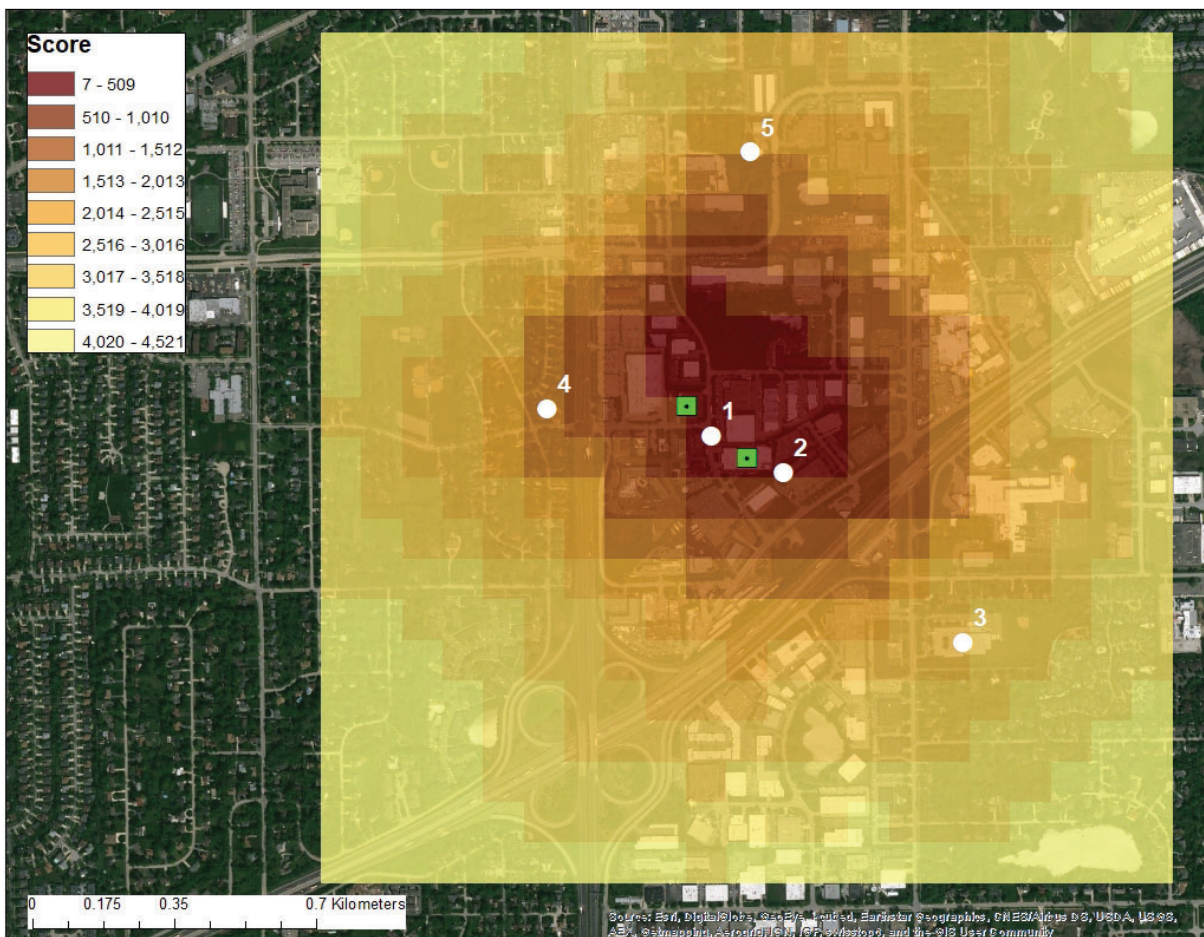

Figure 2-4. Monitor locations and Scoring Results

2.1.2. Monitor Siting guidelines

The EPA OAQPS and Region 5 office will follow the monitor siting criteria detailed in the Code of Federal Regulations (CFR) Chapter 40 Section 58, Appendix E, to the extent possible and/or practical. Though we do not expect strict compliance with standard siting criteria for a monitoring exercise of this scope and with these objectives, the monitoring agencies must consider monitor placement guidelines such as the following:

- a. Locating the sampler in an area that has an unobstructed air flow, especially in the direction of any recognized sources of target analytes.
- b. Avoiding locations that are directly influenced by nearby adjacent, biasing emission sources (e.g., direct vehicle emissions, boiler stacks, backup generators).
- c. Avoiding locations where reactive surfaces may cause chemical changes in the air sampled.
- d. Placing the intake probe(s) of samplers at a representative height between 2 and 7 meters above ground level (AGL).
- e. Recognizing personnel and apparatus security issues, and related accessibility concerns during both weekdays and weekends/holidays.

Given the fact that cigarette or tobacco smoke and vehicle exhaust are additional potential sources of ethylene oxide besides industrial emissions, special attention and consideration will be made to avoid sampling those biasing emission sources.

2.2. Sampling Methods

Measurement consistency is necessary to achieve the program objectives described above. The ability to accurately detect pollutant concentrations and evaluate the resultant data to assess the degree to which associated health risks may be present, requires a considerable level of standardization. This project will follow EPA Compendium Method TO-15 Determination of Volatile Organic Compounds (VOCs) in Air Collected in Specially Prepared Canisters and Analyzed by Gas Chromatography/Mass Spectrometry (GC/MS) for both sampling and analysis methodology.

The sampling apparatus will consist of SUMMA[®] 6-liter canisters and critical orifice passive sampling kits that are calibrated for 24-hour sampling without power requirement. The inlet height will

be approximately 2 m above ground. After 24 hours of sampling, the canister will remain under vacuum (negative pressure), and be shipped to the analytical laboratory (EPA's VOC National Contract Laboratory ERG with an identification tag and a COC.

All canisters are cleaned prior to reuse following ERG's SOP ERG-MOR-105 (SOP for Sample Canister Cleaning using Wasson TO-Clean Automated System). The canisters are cleaned to <3x MDL or 0.2 parts per billion by volume (ppbV), whichever is lower. If the canister fails the Blank criteria, it is returned to the cleaning system bank with the other canisters that were cleaned along with it and all canisters are put through an additional Vacuum and Pressure cycle. The same canister is analyzed again. All canisters are cleaned by the same procedure and are entered into the canister cleanup log.

A mass flow controller (MFC) and/or critical orifice regulates the flow of ambient air into an evacuated passivated stainless steel canister at a known, constant rate over the course of 24 hours. Following completion of collection, the canister is transported to the contract laboratory for analysis within 30 days of collection. Previous studies suggest that most compounds analyzed via TO-15 are stable for up to 30 days in passivated stainless steel canisters; however, the condition of the wetted surfaces of each individual canister is likely to influence the stability of the VOCs. Analysis of the sample as soon as possible after collection is strongly recommended to minimize changes of the collected sample

A 5- μ m pore size silonite stainless steel particulate filter must be installed on the sampling unit inlet for all VOC collection. Failure to install a particulate filter allows particulates such as dust and pollen to adhere to the interior of the sampling unit (valves, MFC, etc.) and to be pulled into the evacuated canister during sample collection. Once inside the canister, particulate matter can form active sites, adsorb analytes, and/or provide reactants which may degrade and form target analytes or interferants, potentially rendering the canister irreversibly contaminated. If the particulate filter is used in areas with high levels of particulate, which may result in decreased flows or decreased collected pressures, it must be replaced.

2.3. Sample Handling and Custody

A color-coded, three-copy canister sample COC form (example in Figure 2-4) is shipped to the field with each 6-liter stainless steel canister. If duplicate or collocated samples are to be taken, two

canisters and two COC forms are sent in the shipping container(s) to the site. When a sample is collected, the site operator fills out the form. The site operator detaches the pink copy to be retained on-site and sends the remaining copies with the canister in the shipping container to ERG's laboratory.

Upon receipt at the analysis laboratory, the sample canister is tagged for laboratory tracking (example figure 2-5) vacuum/pressure is measured and compared against the field documented vacuum/pressure to ensure the canister remained airtight during transport. If the receiving vacuum differs from the field vacuum more than 3" Hg, the laboratory program manager is notified, and sample canister may be voided. Because there are potential differences in barometric pressures and temperatures between the sampling site and the receiving laboratory, and different accuracies for different types of pressure gauges, there can be a consistent difference in final field pressure and lab receipt pressure for canister samples. This difference and other parameters are considered to determine the validity of the canister samples. These are monitored daily, and the pressures are logged into an Excel spreadsheet. This allows the laboratory the ability to determine if the difference is due to gauges or if the canister leaked during transport.

Canisters will be handled with care to ensure that weld integrity is maintained, that the interior canister surface is not compromised, and that the valve-to-canister connection remains intact. Shocks to the surface of the canister may damage welds or create small cracks in the interior canister surface which may expose active sites. Excessive pressure on the canister valve may cause leaks in the seal between the canister valve and canister stem. Shipment of canisters will occur in protective hard-shell boxes and/or sturdy cardboard boxes to ensure canister longevity. Care will be taken to replace any boxes which have lost integrity or rigidity.

More detailed sample receipt procedures and sample acceptance policies are presented in the SOP for Sample Receipt at the ERG Chemistry Laboratory, ERG-MOR-045 and in Appendix C.ERG's QAPP section 9.1.

 ERG Lab ID # _____	
601 Keystone Park Drive, Suite 700, Morrisville, NC 27560	
AIR TOXICS SAMPLE CHAIN OF CUSTODY	
Lab Pre-Sampling	Site Code: _____ City/State: _____ AQS Code: _____ Collection Date: _____ Options: SNMOC (Y/N): _____ TOXICS (Y/N): _____ METHANE (Y/N): _____ Relinquished by: _____ Date: _____
Field Setup	Canister Number: _____ Lab Initial Can. Press. ("Hg): _____ Cleaning Batch # : _____ Date Can. Cleaned: _____ Duplicate Event (Y/N): _____ Duplicate Can # : _____ Received by: _____ Date: _____ Operator: _____ MFC Setting: _____ System #: _____ Elapsed Timer Reset (Y/N): _____ Setup Date: _____ Canister Valve Opened (Y/N): _____ Field Initial Can. Press.: _____ psig psia "Hg (Circle one)
Field Recovery	Recovery Date: _____ Sample Duration (3 or 24 hr): _____ Operator: _____ Elapsed Time: _____ Field Final Can. Press.: _____ psig psia "Hg (Circle one) Status: VALID VOID (Circle one) Canister Valve Closed (Y/N): _____ Relinquished by: _____ Date: _____
Lab Recovery	Received by: _____ Date: _____ Lab Final Can. Press.: _____ psig "Hg (Circle one) Converted to psia: _____ Status: VALID VOID (Circle one) Gauge: 1 2 (Circle one) If void, why: _____
Samples stored in Air Tox Lab (Room 130)	
5-2018	
Comments: _____ _____ _____ _____ _____	

White: Sample Traveler

Canary: Lab Copy

Pink: Field Copy

Figure 2-5. ERG's Sample Chain of Custody Form

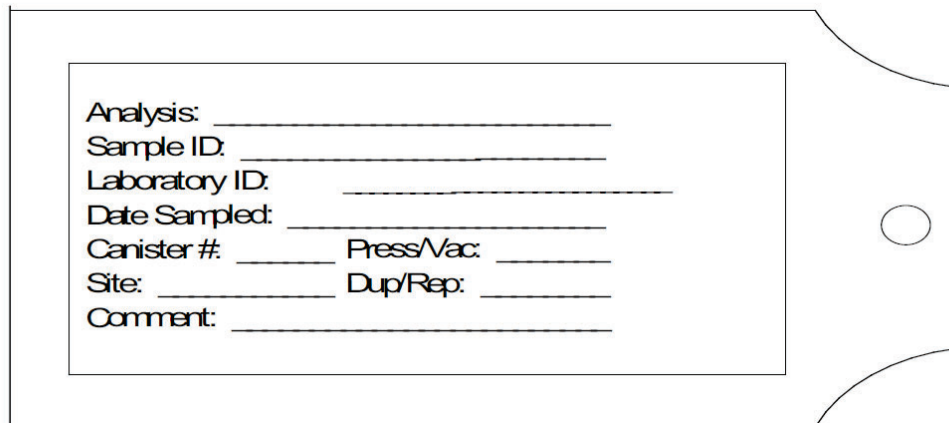

The image shows a sample tracking tag form. It is a rectangular card with a rounded right edge and a small circular hole on the right side. The form contains the following fields for data entry:

- Analysis: _____
- Sample ID: _____
- Laboratory ID: _____
- Date Sampled: _____
- Canister #: _____ Press/Vac: _____
- Site: _____ Dup/Rep: _____
- Comment: _____

Figure 2-6. ERG's Sample Tracking Tag

2.4. Analytical Methods

The primary objective for this project is to collect information on ambient air concentrations of ethylene oxide at a selected list of sites in, and adjacent to, Willowbrook, IL during a defined monitoring period, as described in Section 1.5. To this end, ambient air samples will be characterized using analytical techniques following EPA Compendium Method TO-15 (https://www.epa.gov/sites/production/files/2015-07/documents/epa-to-15_0.pdf).

The subsections below describe both the field and laboratory methods that will be followed to achieve project objectives.

2.5. Field Measurements Methods

Meteorological data (e.g., wind speed and wind direction) will be obtained from a meteorological station located on the roof of the EPA Region 5 Willowbrook warehouse, located adjacent to one of the Sterigenics facilities. Wind speed and direction data will be collected in 1-hour intervals using a MET One Sonic sensor, which will be mounted on a 3 meter tripod. The MET One sensor was certified for wind speed and direction in November 2018. These local data will be supplemented with data from the Chicago Midway airport, located 15 miles to the east. These data will be used to develop pollution roses.

2.6. Field Analyses Methods

No field analysis methods will be performed for this project, this section is not applicable.

2.7. Laboratory Analyses Methods (ERG)

The canister samples will be analyzed by ERG, the laboratory contractor. This project will follow EPA Compendium Method TO-15, “Determination of Volatile Organic Compounds (VOCs) in Air Collected in Specially Prepared Canisters and Analyzed by Gas Chromatography/Mass Spectrometry (GC/MS) for both sampling and analysis methodology⁸”. The analysis method for ethylene oxide will use sample pre-concentration and GC coupled with Mass spectrometer in selected ion monitoring (SIM) mode. In general, to analyze the sample, a known volume of sample is directed from the canister through a solid multisorbent concentrator with helium to dry water vapor in the sample. After the concentration and drying steps are completed, the VOCs in the sample are thermally desorbed, entrained in a carrier gas stream, and then focused in a small volume by trapping on a small volume multisorbent trap. The sample is then released by thermal desorption and carried onto a gas chromatographic column for separation. Mass spectra for individual peaks in the total ion chromatogram are examined with respect to the fragmentation pattern of ions corresponding to various VOCs including the intensity of primary and secondary ions. The fragmentation pattern is compared with stored spectra taken under similar conditions to identify the compound. And the intensity of the primary fragment is compared with the system response to the primary fragment for known amounts of the compound derived from calibration. The use of both gas chromatographic retention time and the generally unique mass fragmentation patterns reduce the chances for misidentification. For ethylene oxide, characteristic primary fragment ion mass (mass to charge, m/z) selected is 29 for quantification, while a list of additional ions including 15, 44, 41 and 56 are also included in aiding the identification process for any coeluting interferences. For additional details, refer to the TO-15 method.

As mentioned in section 2.1.2 since cigarette smoke is another possible source for ethylene oxide, additional screening will be performed to examine the samples for cigarette smoke marker 2,5-

⁸ <https://www3.epa.gov/ttn/amtic/files/ambient/airtox/to-15r.pdf>

dimethylfuran to address any influence from cigarette smoke on the samples.

2.8. Quality Control Requirements

Evaluation of trip and laboratory blanks, calibration standards, internal standards, standard reference materials (SRMs), continuing calibration verification (CCV), and sample replicates will be performed throughout the study. Analytical instrument performance will be assessed daily or more frequently if necessary (see details in ERG's QAPP, Appendix C section 11.3). Lab batch blanks will be checked for each batch of canisters cleaned to ensure thorough cleaning; in addition, two trip blanks will be collected each month to assess any background contamination issues during transport and deployment.

2.9. Field Sampling Quality Control

For Quality Assurance (QA) precision and bias purposes, collocation of a minimum of one sampling site per sampling event will be accomplished. That is, a collocated sample will be collected at one of the sampling sites per sampling event, and this collocated sampling site shall rotate through the sampling sites if above MDL concentrations are observed at sites other than the two maximum receptor sites (Willowbrook Village Hall and EPA Willowbrook Warehouse). Until sufficient data are collected to determine if there are detectable results at any of the other six sampling locations, an initial minimal rotation of collocated sampling between the two maximum receptor sites will be conducted. The collocated sample will require a separate sample inlet for each canister at the collocated site.

2.10. Field Measurement/Analysis Quality Control

2.10.1. Field Measurement QC

Prior to sampling, field operators will perform a leak check on each canister/flow regulator set up following the procedures found in *ERG Sampling Procedures for Passive Vacuum Regulators* (see Appendix B).

The field staff must note any deviations from the sample plan or procedure on the sample label and field logbook, along with anything unusual or unexpected that may influence the sample results (i.e. markers, vehicle fuels, newly paved roads, nearby non-target activities, etc.). The field staff will also document anything unusual in the field with photographs (stolen or damaged equipment in the field,

toppled tripod, etc.)

2.11. Laboratory Analysis Quality Control

Laboratory QC procedures are provided in Table 11-2, “Summary of Air Toxics Canister VOC Quality Control Procedures”, in the ERG QAPP in Appendix C. The tune of the GC/MS is verified using a 4-Bromofluorobenzene (BFB) instrument performance check sample daily. The acceptance criteria for the BFB are presented in Table 11-3 of the ERG QAPP. The internal standards for this method are hexane-d14, 1,4-difluorobenzene, and chlorobenzene-d5. The internal standard responses must be evaluated to ensure instrument stability throughout the day. Before sample analyses, a standard prepared at approximately 2.5 ppbV from a NIST traceable gas cylinder is used for a continuing calibration verification (CCV). The resulting response factor for each compound is compared to the average calibration curve response factors generated from the GC/MS. Correspondence within an absolute value of less than or equal to 30 percent difference is considered acceptable for the quantitated compounds. If the first CCV does not meet this criterion, a second CCV will be analyzed. If the second CCV is acceptable, sample analysis can continue. If the second CCV does not meet acceptance criteria, then a leak check and system maintenance are performed. If the system maintenance is completed and a third CCV analysis meets the criterion, then analysis may continue. If the maintenance causes a change in the system response, a new calibration curve must be analyzed before sample analyses can begin.

2.12. Instrument/Equipment Testing, Inspection, and Maintenance

See ERG Sampling Procedures for Passive Vacuum Regulators in Appendix B.

2.13. Field Measurement Instruments/Equipment

Six-liter stainless steel passivated canisters will be used for the project. The canisters will be provided by ERG and fitted with particulate filters, fixed orifice flow controllers, and suitable inlets (see Figure 2-7 and 2-8). The canisters will be placed on canister tripod stands for sampling. It is strongly recommended that the initial canister pressure be checked prior to sample collection by measurement of the canister vacuum with a calibrated pressure gauge or pressure transducer. If a built-in gauge on the sampling unit cannot be calibrated, a standalone gauge will be employed for this measurement. This initial pressure will be documented on the sample collection form. Canisters must show > 28 inches Hg

vacuum to conduct sampling.

Once vacuum is verified, the canister is connected to the sampling unit and a leak check is performed. A leak check may be performed by quickly opening and closing the valve of the canister to generate a vacuum in the sampling unit. The vacuum/pressure gauge in the sampling unit will be observed for a minimum of 5 minutes to ensure that the vacuum does not change by more than 0.2 psi. For more detail regarding the collection of samples using stainless steel canisters, refer to Section 4.2.3 of the NATTS TAD in Appendix D.



Figure 2-7. Canister setup with Passive Vacuum Regulator.



Figure 2-8. Canisters with tripod stand setup at Willowbrook Village Hall site.

2.14. Laboratory Analysis Instruments/Equipment (ERG)

To ensure the quality of the sampling and analytical equipment, ERG conducts performance checks for all equipment used in each of the programs. ERG checks the sampling systems annually, and makes repairs as needed. ERG tracks the performance of the analytical instrumentation to ensure proper operation. ERG also maintains a spare parts inventory to shorten equipment downtime. Table 12-1 (Preventative Maintenance in ERG Laboratories) of the ERG QAPP in Appendix C includes the details on maintenance items, how frequently they will be performed, and who is responsible for performing the maintenance.

2.15. Instrument/Equipment Calibration and Frequency

2.15.1. Field Measurement Instruments/Equipment

ERG performs a canister leak check and blank check on each canister annually. The initial canister pressure/vacuum is checked prior to sampling. The initial pressure will be documented on the sample collection COC form. Canisters must show > 28 inches Hg vacuum to conduct sampling. Once vacuum is verified, the canister is connected to the sampling unit and a leak check is performed. A leak is performed in the field by quickly opening and closing the valve of the canister to generate a vacuum in the sampling unit. The vacuum/pressure gauge in the sampling unit will be observed for a minimum of 5 minutes to ensure that the vacuum does not change by more than 1 in Hg. The vacuum/pressure gauges are calibrated initially before use, and on an as needed basis, every 3-4 months. Particulate filters are disposable and replaced if the sampling flow rate or final canister pressure/vacuum indicates a blockage or buildup of particulates.

2.15.2. Laboratory Analysis Instruments/Equipment (ERG)

Calibration of the GC/FID/MS used for TO-15 analysis is accomplished quarterly (at a minimum) by analyzing humidified calibration standards prepared in canisters generated from NIST-traceable gas standards. The certified standards contain the VOC target compounds at approximately 500 parts per billion by volume (ppbV). Initial calibration standards are prepared at nominal concentrations of 0.25, 0.5, 1, 2.5, 5, and 10 ppbV for the target compound (a minimum of 5 levels are required). All standards and samples are analyzed with the following internal standards: n-hexane-d14, 1,4-difluorobenzene, and chlorobenzene-d5. The calibration requires average response factors (RRF), based on the internal standard, of ± 30 percent RSD. The CCV is made from a second source certified gas at an average concentration of 2.5 ppbV. The CCV must have RRFs within $\pm 30\%$ of the mean initial calibration RRFs. Refer to Section 13 of ERG QAPP in Appendix C.

2.16. Inspection/Acceptance Requirements for Supplies and Consumables

2.16.1. Field Sampling Supplies and Consumables

Sampling canisters, vacuum gauges, particulate filters, and sampling inlets are provided by ERG.

There are no field sampling consumables other than particulate filters (see Section 2.7.1). Refer to APPENDIX B. ERG Sampling Procedures for Passive Vacuum Regulators for required checks on the sampling canisters to be performed in the field.

2.16.2. Laboratory Analyses Supplies and Consumables

The purpose of this element is to establish and document a system for inspecting and accepting all supplies and consumables that may directly or indirectly affect the quality of the data. All supplies and consumables are inspected and accepted or rejected upon receipt in the laboratory. The ERG employee who ordered the supply is responsible for verifying that the order is acceptably delivered, stored and dispersed upon receipt in the laboratory. The recipient's signature on the packing slip indicates the received goods were received and are acceptable. Refer to Table 14-1 (Critical Supplies and Consumables) and Section 14 of the ERG QAPP in Appendix C for more detailed information.

2.17. Data Acquisition Requirements (Non-Direct Measurements)

See Section 2.1 for non-direct measurements used as inputs into AERMOD to determine sampling locations.

2.18. Data Management

Data management is largely managed by ERG. Field sampling operators in Region 5 will be responsible for completion of the field COC forms (Figure 2-4). When a sample is collected, the site operator fills out the COC form. The site operator detaches the pink copy to be retained on-site and sends the remaining copies with the canister in the shipping container to ERG's laboratory. ERG's data management for sample data is presented in Figure 2-7. The sample data path is shown from sample origination to data reporting and storage. Refer to Section 15 of the ERG QAPP in Appendix C for more detailed information.

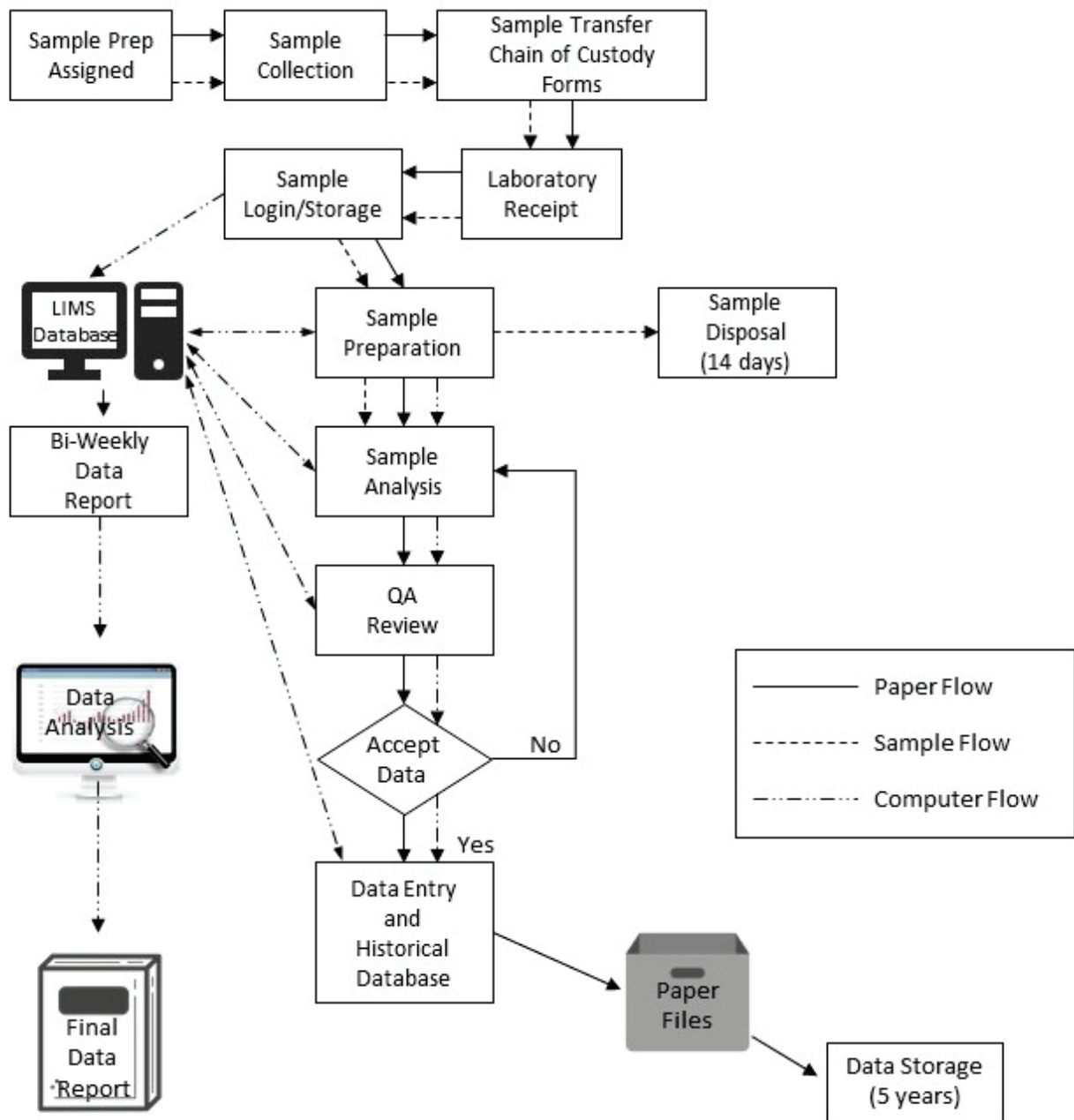

Figure 2-9. Data management and sample flow diagram.

3. ASSESSMENTS AND OVERSIGHT

3.1. Assessments/Oversight and Response Actions

An assessment is defined as an evaluation process used to measure the performance or effectiveness of the quality system and various measurement phases of the data operation. EPA and ERG will be performing the assessments explained in this section.

3.1.1. Field and Laboratory Technical Systems Audits

A TSA is a thorough and systematic on-site qualitative audit, where facilities, equipment, personnel, training, procedures, subcontractor systems, and record keeping are examined for conformance to the QAPP.

A field TSA will be performed by OAQPS once all initial field sites are set up and running. It is anticipated the audit occurring early to mid-December 2018. The audit will consist of a thorough review of the field personnel implementing the standard operating procedures for this activity including: sample canister receipt and installation; sampler and site maintenance, quality control checks, log book and data entry (forms); sample chain of custody and sample shipment. If the field activity is not being implemented correctly and the auditor feels that data quality is compromised the auditor has the authority to halt data collection activities until corrective action is implemented. Any sample collected prior to the audit will be qualified appropriately. A summary report will be prepared by the auditor before existing the audit and a full report will be provided to the field personnel no later than two weeks from the completion of the audit. Due to the simplified nature of the field activities only one audit will be conducted unless serious findings that affect data quality are identified. As part of corrective action and follow-up, an audit finding response letter will be generated by the Region 5 field office Program Manager. The audit finding response letter will address what actions are being implemented to correct the finding(s) of the TSA and in what timeframe. Audit reports and corrective action reports will be filed with the OAQPS Monitoring Lead.

A laboratory TSA will be conducted by OAQPS in early to mid-December. The audit will consist of a thorough review of the laboratory personnel and activities related to this QAPP and the SOPs designated for use in this project. If the laboratory activity is not being implemented correctly and

the auditor feels that data quality is compromised the auditor has the authority to halt sample analysis activities until corrective action is implemented. Any sample collected prior to the audit will be flagged appropriately. A summary report will be prepared by the auditor before existing the audit. Specific areas will be discussed, and an attempt made to rank them in order of their potential impact on data quality. A full report will be provided to the field personnel no later than two weeks from the completion of the audit. Due to the timeframe for data collection, one audit will be conducted unless serious findings that affect data quality are identified. The external TSAs will be performed by EPA at the ERG Laboratory. The EPA audit team will prepare a brief written summary of findings for the ERG Program Manager and Program QA Coordinator. As part of corrective action and follow-up, an audit finding response letter will be generated by the ERG Program Manager and Program QA Coordinator. The audit finding response letter will address what actions are being implemented to correct the finding(s) of the TSA and in what timeframe. See figure 3-1 for a copy of ERG corrective action report form. See ERG QAPP section 16.1 for more details (Appendix C). Audit reports and corrective action reports will be filed with the OAQPS Monitoring Lead.

ERG has internal QA staff that perform an annual internal systems audits of laboratory analysis activities contracted to EPA. Section 16 of the ERG NATTS QAPP explains the TSA procedure.

CAR Number: 2018-



Corrective Action Report

CAR Initiator: _____ Initiation Date: _____

Area/Procedure Affected: Click or tap here to enter text.

Is Immediate Stop of Work Required? Choose an item.

Non-Conformance

Date of Discovery: _____

Description of Non-Conformance: What happened? How is this a non-conforming event?

Click or tap here to enter text.

Investigation of Non-Conformance: How was the non-conformance discovered?

Click or tap here to enter text.

Impact Assessment: What is affected by the nonconformance?

Click or tap here to enter text.

Root Cause Analysis: What caused the nonconformance?

Click or tap here to enter text.

Further Analysis: Could this nonconformance be evident in other areas?

Click or tap here to enter text.

Corrective Action

Due Date for Remedial Action Completion: _____

Immediate and/or Long-Term Remedial Corrective Actions Taken: _____

Assessment of Corrective Action Effectiveness: _____

Click or tap here to enter text.

Signatures

	Signature & Date	Comments
QA Officer:	_____	<small>Click or tap here to enter text.</small>
Project Manager:	_____	<small>Click or tap here to enter text.</small>
Initiator:	_____	<small>Click or tap here to enter text.</small>

Follow-up

Reference or attach documentation that demonstrates the return to conformance, or describe below.

Click or tap here to enter text.

Follow-up Auditor: Click or tap here to enter text.

Date Completed: _____

Were corrective action procedures effective?

Click or tap here to enter text.

Figure 3-1. ERG's corrective action report form.

3.1.2. Data Quality Assessments

Data quality assessment is the scientific and statistical evaluation of data to determine if data obtained from environmental data operations are of the right type, quality, and quantity to support their intended use. This assessment is built on a fundamental premise: data quality, as a concept, is meaningful only when it relates to the intended use of the data.

An audit of data quality (ADQ) reveals how the data were handled, what judgments were made, and whether uncorrected mistakes were made. Performed prior to producing a program activity's final report, ADQs can often identify the means to correct systematic data reduction errors.

These audits involve an extensive review of all the data used to generate the final result, including a review of instrument print-outs and other raw data, spreadsheets used to calculate and summarize data, and field data.

For this project, an ADQ will be performed on 10% of the sample and QC data every two weeks by EPA on data submitted by ERG. This audit may be performed at ERG to facilitate the review of instrument data, notebooks and other laboratory and field documentation used to calculate the results. Any issues identified will be documented and resolved before any data are released by EPA.

ERG Data Assessments

ERG, as part of the EPA NATTS contract will also provide data assessments that are described in section 16.1.4 of the NATTS QAPP. EPA will use these assessments in final QA reports for this project.

3.2. Reports to Management

Analytical data reports prepared by ERG are sent to the EPA OAQPS Monitoring Lead on a biweekly basis following sample collection. These reports will be delivered in both Excel and Adobe pdf formats. These reports will include the analytical data for each sample collected including: sample name, lab number, target compound, canister number, sample results (ppbv and ug/m³), method detection limit, sample matrix, sample date, sample receipt date, and other supporting laboratory documentation. Quality control data will also be included in the reports including blanks, duplicates, and calibration checks (continuing calibration verifications). The EPA OAQPS Monitoring Lead will

file the reports and make them available for QA review by the EPA Quality Assurance Manager. Regular reports to EPA provide the opportunity to identify and alert staff of data quality problems, to implement corrective action, and to procure necessary additional resources. Biweekly meetings of ERG personnel with EPA monitoring and QA staff, both headquarters and regional staff, will provide a means for effective communication of sampling results, trends identified in the data, ensuring scheduled delivery of data and reports, and identification of any deviation from the approved QAPP and plans.

A final report will also be completed following the study to summarize the details of the sampling performed, the concentration results, as well as any data analysis conducted. Detail regarding the contents of this report may be found in Section 1.9.4 Final Reports.

4. DATA REVIEW AND USABILITY

4.1. Data Review, Verification, and Validation Requirements

Information used to verify ethylene oxide air concentration data, includes:

- a. Sample COCs, holding times, preservation methods;
- b. Multi-point calibrations – the multipoint calibrations are used to establish proper initial calibration and can be used to show changes in instrument response;
- c. Standards – certifications, identification, expiration dates;
- d. Instrument logs – all activities and samples analyzed are entered into the LIMS logs (batches, sequences, etc.) to track the samples throughout the measurements procedures;
- e. Supporting equipment – identification, certifications, calibration, if needed;
- f. Blank, CCVs, replicate and spike results – these QC indicators can be used to ascertain whether sample handling or analysis is causing bias in the data set.

The reliability and acceptability of environmental analytical information depends on the rigorous completion of all the requirements outlined in the QA/QC protocol. During data analysis and validation, data are filtered and accepted or rejected based on the set of QC criteria list in Table 1-1 and in section 2.5. More details can be found in ERG QAPP section 11.3 (Appendix C).

4.2. Verification and Validation Methods

Sample data is examined for representativeness, completeness, precision, and bias. Data validation is performed by examination of objective evidence that the requirements for a specific intended use are fulfilled as presented in Section 2.5. For the analytical data, the entries are reviewed to reduce the possibility of entry and transcription errors. Once the data are transferred to the ERG LIMS database, the data will be reviewed for routine data outliers and data outside acceptance criteria. These data will be flagged appropriately. Prior to reporting, 100 percent of the data is reviewed by ERG Task Leader and 10 percent of the database is checked by ERG QA Coordinator or designated reviewer.

4.3. Reconciliation with User Requirements

A preliminary data review will be performed to uncover potential limitations to using the data, to reveal outliers, and generally to explore the basic structure of the data. The next step is to calculate basic summary statistics, generate graphical presentations of the data, and review these summary statistics and graphs to determine if representativeness, comparability, completeness, precision, bias, and sensitivity, were met. Representativeness can be assessed with site location information and is based on potential sources and select weather station information. Comparability is based on method measure of the level of confidence with which one data set can be compared to another. Completeness is measured by the amount of valid sample data obtained compared to what was expected. Precision is determined from replicate collocate analyses. Sensitivity is demonstrated through MDLs.

If the sampling design and statistical tests conducted during the final reporting process show results that meet acceptance criteria, it can be assumed that the network design and the uncertainty of the data are acceptable. Further use of the data will include characterizing concentrations in potentially affected nearby neighborhoods based on method sensitivity; evaluating ethylene oxide fugitive emissions from Sterigenics by OAQPS' Measurement Technology Group; health risk assessment by OAQPS's Air Toxics Assessment Group of Health and Environmental Impacts Division.

5. REFERENCES

1. U.S. Environmental Protection Agency. Evaluation of the Inhalation Carcinogenicity of Ethylene Oxide (CASRN 75-21-8) In Support of Summary Information on the Integrated Risk Information System(IRIS). National Center for Environmental Assessment, Office of Research and Development. Washington, DC. EPA/635/R-16/350Fa. 2016.
https://cfpub.epa.gov/ncea/iris/iris_documents/documents/toxreviews/1025tr.pdf
2. EPA Compendium Method TO-15, Determination of Volatile Organic Compounds (VOCs) in Air Collected in Specially Prepared Canisters and Analyzed by Gas Chromatography/Mass Spectrometry (GC/MS) for both sampling and analysis methodology, 1999.
https://www.epa.gov/sites/production/files/2015-07/documents/epa-to-15_0.pdf
3. ENVIRONMENTAL PROTECTION AGENCY 40 CFR Part 136 [EPA–HQ–OW–2014–0797; FRL–9957–24– OW] RIN 2040–AF48 Clean Water Act Methods Update Rule for the Analysis of Effluent. 2017. <https://www.gpo.gov/fdsys/pkg/FR-2017-08-28/pdf/2017-17271.pdf>
4. National Air Toxics Trends Stations (NATTS) program’s Technical Assistance Document, 2016.
https://www3.epa.gov/ttn/amtic/files/ambient/airtox/NATTS%20TAD%20Revision%203_FINAL%20October%202016.pdf

6. APPENDICES

APPENDIX A. Ethylene Oxide Sampling Calendar

APPENDIX B. ERG Sampling Procedures for Passive Vacuum Regulators

APPENDIX C. ERG's QAPP, "SUPPORT FOR THE EPA NATIONAL MONITORING PROGRAMS," (ERG-QAPP-0344-4).

APPENDIX D. TECHNICAL ASSISTANCE DOCUMENT FOR THE NATIONAL AIR TOXICS TRENDS STATIONS PROGRAM, Revision 3

APPENDIX E. Standard Operating Procedure for Collection of VOC Samples (R5-ARD-0003-r5)

APPENDICES

APPENDIX A. Ethylene Oxide Sampling Calendar

2018/2019 3-Day Sampling Calendar - EtO

November						
Sun	Mon	Tue	Wed	Thu	Fri	Sat
				1	2	3
4	5	6	7	8	9	10
11	12	13	14	15	TB	17
18	19	20	21	22	23	24
25	26	27	TB	29	30	

December						
Sun	Mon	Tue	Wed	Thu	Fri	Sat
						1
2	3	4	5	6	7	8
9	10	11	12	TB	14	15
16	17	18	19	20	21	22
23	24	25	26	27	28	29
30	TB					

January						
Sun	Mon	Tue	Wed	Thu	Fri	Sat
		1	2	3	4	5
6	7	8	9	10	11	12
13	14	TB	16	17	18	19
20	21	22	23	24	25	26
27	28	29	TB	31		

February						
Sun	Mon	Tue	Wed	Thu	Fri	Sat
					1	2
3	4	5	6	7	8	9
10	11	12	13	TB	15	16
17	18	19	20	21	22	23
24	25	TB	27	28		

Standard Sample Collection

TB Field Blank Collection

APPENDIX B. ERG Sampling Procedures for Passive Vacuum Regulators

Sampling Procedures for Passive Vacuum Regulators

The procedure presented is designed for sampling volatile organic compounds (VOCs) in ambient air, based on the collection of whole air samples in SUMMA[®] treated canisters to final pressures below atmospheric. The samples are then analyzed using EPA Compendium Method TO-15 *Determination of Volatile Organic Compounds (VOCs) in Air Collected in Specially Prepared Canisters and Analyzed by Gas Chromatography/Mass Spectrometry (GC/MS)* and the EPA National Monitoring Program's contract laboratory (i.e. ERG following the Category 1, EPA approved "Support for the EPA National Monitoring Programs" QAPP).

Laboratory Analysis Methodology using the TO-15 method may be referenced by contacting the Eastern Research Group (ERG) directly at 919-468-7824 or by email to Julie.Swift@erg.com.

I. INSTALLATION

A. Sampler Siting

Designate the address or GPS coordinates on the Chain of Custody (COC) form.

The sampler should be mounted in a location that is unobstructed on all sides. There should be no tree limbs or other hanging obstructions above the sampler. It is suggested that the horizontal distance from the sampler to the closest vertical obstruction higher than the sampler be at least twice the height of the vertical obstruction. The inlet of the sampling system must be positioned at least 2 meters above grade (ideal), but not more than 5 meters above grade.

B. Sampler Installation

1. The sampling system consists of two components: a sample canister and a passive vacuum regulator (Veriflow vacuum regulator with gauge and sample inlet probe). The canisters have been cleaned, tested for contamination (blanked) and evacuated, the passive collection assemblies will have been cleaned, tested for contamination (blanked), and calibrated for 24-hour integrated sampling.



2. The complete sampling system must be securely mounted on a support structure which ensures that the sample inlet meets the siting criteria (at least 2 meters above grade, but not more than 5 meters above grade).
3. For collocated samplers, horizontal spacing should be between 0 and 4 meters, and inlet heights within 1 meter vertically.

II. OPERATING PROCEDURE

A. Equipment and Supplies

- 6-liter sample collection canister
- Veriflow vacuum regulator/gauge/inlet probe (passive collection assembly)
- ERG COC form

B. Sampler and Sample Media Receipt Activities

Complete Sampling System

1. Check parts and components to ensure none is damaged.
2. Ensure all fittings are present and in good condition.
3. Prior to sampling keep all sampling system components in a clean area free of contamination.

Sample Collection Canister

1. The sample collection canister and associated sample COC will arrive via air freight from ERG in a cardboard box.

Note: The canisters do not need to be refrigerated after receipt or during return shipping.

2. Ensure the canister is not damaged. Confirm that the valve remained in the closed position during shipping and that the top plug is secured on the bellows valve inlet fitting.

C. Preparing for a Sampling Event

1. Prepare sample paperwork. On the ERG Toxics/SNMOC COC, supply all required information in the “Lab Pre-Sampling” section. Record any pertinent observations in the “Comments” section at the bottom of the form.
2. Remove the plug attached to the bellows valve inlet. Retain the plug in a clean place so that it can be used to reseal the bellows valve inlet after the sampling event.
3. Assemble the complete sampling system.
 - a. Attach the outlet fitting of the Veriflow vacuum controller to the canister bellows valve inlet fitting.

Note: Do not over tighten the fitting nut. When the fitting nut feels snug by hand, another quarter turn should be sufficient to secure the controller inlet to the can.

- b. Ensure that the plug at the inlet of the Veriflow remains tight in order to perform a leak check.

Perform a leak check by opening and then immediately closing the canister valve. Observe the vacuum reading on the Veriflow gauge. If the vacuum changes by more than 1 in Hg over 5 minutes, ensure that all fittings are tight. If all fittings are tight, then assemble another sampling system using another canister and repeat steps 2 and 3.

D. Sampling and Data Collection

1. Record the initial collection start time and date in “Setup Date:” in the “Field Setup” section on the COC form. Fully open the canister bellows valve. Observe the pressure (i.e., “Hg vacuum”) indicated on the gauge.
2. After 24 hours, read the gauge and record the remaining pressure left in the can on the ERG Toxics/SNMOC Sample Data Sheet and record the reading in the “Field Recovery”, “Field Final Can. Press. (“Hg)”



blank. If the pressure is zero, note the lack of pressure in the “Comments” section of the form.

3. Close the canister bellows valve fully.
4. Disconnect the canister from Veriflow vacuum controller by unfastening the Veriflow outlet fitting from the canister bellows valve inlet fitting.
5. Replace and secure the retained plug on the canister bellows valve.
6. On the ERG Toxics/SNMOC Sample Data Sheet, supply all required information in the “Field Recovery” section. Be sure to record any observations that were made during the run period in the “Comments:” section.

E. Sample Shipping

- a. Remove the pink copy of the ERG Toxics/SNMOC Sample Data Sheet and file in a site record.
- b. Pack the can and the completed white/yellow copy of the ERG Toxics/SNMOC Sample Data Sheet in the original cardboard shipping box and tape it closed. The can does NOT need to be shipped cold.
- c. Use the pre-filled out UPS label provided by ERG, and fill out the “Sender” section with the sampling agency’s address and phone number. Send priority overnight to ERG at the address below.

ERG
601 Keystone Park Drive
Suite 700
Morrisville, NC 27560
919-468-7924

Note: if the shipping form is lost, use the address above for shipping to ERG, and contact them directly for the UPS accounting number.

APPENDIX C. ERG's QAPP, "SUPPORT FOR
THE EPA NATIONAL MONITORING
PROGRAMS," (ERG-QAPP-0344-4).

SUPPORT FOR THE EPA NATIONAL MONITORING PROGRAMS

**(UATMP, NATTS, CSATAM, PAMS, and NMOC
Support)**

Contract No. EP-D-14-030

2018

**Quality Assurance Project Plan
Category 1**

Eastern Research Group, Inc.
601 Keystone Park Drive, Suite 700
Morrisville, NC 27560

2018 Quality Assurance Project Plan, Category 1
UATMP, NATTS, CSATAM, PAMS, and NMOC Support (Contract No. EP-D-14-030)

Approved by:

U.S. EPA Project Officer:  Date: 7/26/18

U.S. EPA QA Manager:  Date: 7/26/18

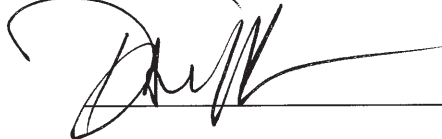
U.S. EPA Delivery Order Manager:  Date: 7/26/18

ERG Program Manager: Julie C. Swift Date: 7/27/18

ERG Deputy Program Manager: Kaura Van Emyle Date: 7/27/18

ERG Program QA Officer: Donna Tedder Date: 7/27/18

ERG Deputy Program QA Officer: Jeanette Nash Date: 7/27/18

DISCLAIMER

This Category 1 Quality Assurance Project Plan has been prepared specifically to address the operation and management of the U.S. EPA National Monitoring Programs (UATMP, NATTS, CSATAM, PAMS and NMOC). The contents have been prepared in accordance with Level I Specifications of the EPA Requirements for Quality Assurance Project Plans, EPA QA/R-5 and the EPA Guidance for Quality Assurance Project Plans, EPA QA/G-5.

TABLE OF CONTENTS

Section

PROJECT MANAGEMENT

1	Project/Task Organization.....	1 of 8
1.1	Assignment of Program Personnel.....	1 of 8
1.1.1	Program Manager.....	2 of 8
1.1.2	Deputy Program Manager.....	2 of 8
1.1.3	Program Technical Adviser.....	3 of 8
1.1.4	Program QA Coordinator.....	3 of 8
1.1.5	Deputy Program QA Coordinator.....	3 of 8
1.1.6	Task Leaders.....	4 of 8
2	Problem Definition/Background.....	1 of 3
3	Project/Task Description.....	1 of 4
3.1	PAMS, NMOC and SNMOC.....	1 of 4
3.2	UATMP, NATTS and CSATAM.....	2 of 4
4	Data Quality Objectives and Criteria for Measurement Data.....	1 of 5
5	Special Training Requirements/Certification.....	1 of 2
5.1	Field Activities Training Personnel.....	1 of 2
5.2	Analytical Laboratory Personnel.....	2 of 2
6	Documentation and Records.....	1 of 6
6.1	Data Management.....	1 of 6
6.2	Preliminary Monthly Data Reports.....	1 of 6
6.3	Quarterly QA Report.....	2 of 6
6.4	Annual Summary Reports Submitted to EPA.....	2 of 6
6.5	Records and Supporting Data.....	3 of 6
6.5.1	Notebooks.....	4 of 6
6.5.2	Electronic Data Collection.....	5 of 6
6.6	Data Reporting Package Archiving and Retrieval.....	5 of 6
6.7	Quality System Document Control.....	5 of 6

MEASUREMENT DATA ACQUISITION

7	Sampling Process Design.....	1 of 10
7.1	NMOC and SNMOC Canister Samplers.....	1 of 10
7.2	VOC and Carbonyl 24-Hour Samplers.....	4 of 10
7.3	Carbonyl Only 24-Hour Samplers.....	5 of 10
7.4	Hexavalent Chromium Samplers.....	8 of 10
7.5	PAMS Sampling.....	10 of 10
7.6	HAPS Sampling.....	10 of 10
8	Sampling Method Requirements.....	1 of 1

TABLE OF CONTENTS (Continued)

Section

9 Sample Handling and Custody Requirements..... 1 of 16
 9.1 Canister Sample Custody 1 of 16
 9.1.1 Canister Custody 1 of 16
 9.1.2 Canister Analytical Routing Schedule 6 of 16
 9.1.3 Canister Cleanup 6 of 16
 9.2 Carbonyl Sample Custody..... 9 of 16
 9.2.1 Carbonyl Analytical Routing Schedule..... 9 of 16
 9.3 HAPs Sample Custody 11 of 16
 9.4 Invalid Samples 11 of 16
 9.5 Analytical Data..... 16 of 16
 9.6 Sample Monitoring Data 16 of 16

10 Analytical Methods Requirements 1 of 13
 10.1 Canister Cleanup System 1 of 13
 10.1.1 Heated Canister Cleaning System 2 of 13
 10.1.2 Unheated Canister Cleaning System 4 of 13
 10.2 VOC and Concurrent Analytical Systems..... 7 of 13
 10.3 Carbonyl Analytical Systems 9 of 13
 10.4 Polycyclic Aromatic Hydrocarbons Analytical Systems 10 of 13
 10.5 Metals Using an Inductively Coupled Argon Plasma Mass Spectrometry Analytical System..... 11 of 13
 10.6 Hexavalent Chromium Analytical System 12 of 13

11 Quality Control Requirements 1 of 40
 11.1 Sample Canister Integrity Studies 1 of 40
 11.2 Standard Traceability 1 of 40
 11.3 Accuracy and Acceptance 2 of 40
 11.3.1 SNMOC Analysis..... 2 of 40
 11.3.2 VOC Analysis 3 of 40
 11.3.3 Carbonyl Compound Analysis 8 of 40
 11.3.4 PAH Analysis 9 of 40
 11.3.5 Metals Analysis 21 of 40
 11.3.6 Hexavalent Chromium Analysis 28 of 40
 11.4 Precision 31 of 40
 11.5 Completeness 31 of 40
 11.6 Representativeness 32 of 40
 11.7 Sensitivity (Method Detection Limits)..... 32 of 40

12 Instrument/Equipment Testing, Inspection, and Maintenance Requirements..... 1 of 4
 12.1 SNMOC, VOC, and PAMS..... 3 of 4
 12.2 Carbonyls 3 of 4
 12.3 HAPs 3 of 4

TABLE OF CONTENTS (Continued)

Section

13	Instrument Calibration and Frequency	1 of 7
13.1	SNMOC Calibration.....	1 of 7
13.2	VOC Calibration	2 of 7
13.3	Carbonyl Calibration.....	4 of 7
13.4	HAPs Calibration	5 of 7
13.5	Laboratory Support Equipment Calibration.....	6 of 7
14	Inspection/Acceptance for Supplies and Consumables.....	1 of 5
14.1	Purpose	1 of 5
14.2	Critical Supplies and Consumables.....	1 of 5
14.3	Acceptance Criteria	1 of 5
15	Data Management	1 of 7
15.1	Data Recording.....	1 of 7
15.2	Data Validation	3 of 7
15.3	Data Reduction and Transformation	3 of 7
15.4	Data Transmittal.....	4 of 7
15.5	Data Summary.....	5 of 7
15.6	Data Tracking.....	6 of 7
15.7	Data Storage and Retrieval.....	7 of 7

ASSESSMENT/OVERSIGHT

16	Assessments and Response Actions.....	1 of 7
16.1	Assessment Activities and Project Planning.....	1 of 7
16.1.1	External Technical Systems and Data Quality Audits	1 of 7
16.1.2	Internal Technical Systems Audits.....	2 of 7
16.1.3	Proficiency Testing	3 of 7
16.1.4	Data Assessment for Final Report.....	4 of 7
16.2	Documentation of Assessments	4 of 7
16.2.1	TSA, Data Quality Audit, and PT Documentation.....	4 of 7
16.2.2	Internal Data Review Documentation	4 of 7
16.3	Corrective Action Reports.....	5 of 7
17	Reports to Management	1 of 2
17.1	Frequency, Content, and Distribution of Reports	1 of 2
17.1.1	Monthly and Annual Reports	1 of 2
17.1.2	Internal Technical System Audit Reports	2 of 2

DATA VALIDATION AND USABILITY

18	Data Review and Verification	1 of 11
18.1	Data Review Design.....	1 of 11
18.2	Data Verification	2 of 11
18.3	Data Review	2 of 11
18.4	Data Reduction and Reporting	3 of 11
18.5	Data Validation	4 of 11

18.6	Air Quality System.....	5 of 11
18.6.1	AQS Flagging and Reporting.....	6 of 11
19	Data Validation, Verification and Analysis	1 of 2
19.1	Process for Validating and Verifying Data	1 of 2
19.1.1	Verification of Data.....	1 of 2
19.1.2	Validation of Data	1 of 2
19.2	Data Analysis	2 of 2
20	Reconciliation with Data Quality Objectives.....	1 of 1
20.1	Conduct Preliminary Data Review.....	1 of 1
20.2	Draw Conclusions from the Data	1 of 1
21	References	1 of 2

APPENDICES

A	Exemptions Table
B	2018 Sampling Schedule
C	ERG Standard Operating Procedures
ERG-MOR-003B	Field Procedure for Collecting Ambient Air Toxics and Carbonyl Compounds Samples Using the ERG:AT/C Sampling System (with O ₃ Denuder Scrubber)
ERG-MOR-003C	Field Procedure for Collecting Ambient Air Toxics and Carbonyl Compounds Samples Using the ERG(C):AT/C Sampling System (with O ₃ Denuder Scrubber)
ERG-MOR-003D	Field Procedure for Collecting Ambient Air Toxics and Carbonyl Compounds Samples Using the ERG:AT/C Sampling System (with O ₃ Denuder Scrubber and Mass Flow Meter)
ERG-MOR-005	Standard Operating Procedure for the Concurrent GC/FID/MS Analysis of Canister Air Toxic Samples using EPA Compendium Method TO-15 and EPA Ozone Precursor Method
ERG-MOR-013	Field Procedure for Collecting Ambient Air Hexavalent Chromium Samples Using the ERG:CR6 Sampling System
ERG-MOR-017	Standard Operating Procedure for Developing, Documenting, and Evaluating the Accuracy of Spreadsheet Data
ERG-MOR-022	Standard Operating Procedure for the Preparation of Standards in the ERG Laboratory
ERG-MOR-024	Standard Operating Procedure for Preparing, Extracting, and Analyzing DNPH Carbonyl Cartridges by Method TO-11A

ERG-MOR-030	Standard Operating Procedure for Canister Sampling System Certification Procedures
ERG-MOR-033	Standard Operating Procedure for Hazardous Waste
ERG-MOR-039	Standard Operating Procedure for Maintaining Laboratory Notebooks
ERG-MOR-044*	Standard Operating Procedure for Method 8270C – GC/MS Analysis of Semivolatile Organics
ERG-MOR-045	Standard Operating Procedure for Sample Receipt at the ERG Chemistry Laboratory
ERG-MOR-046*	Field Procedure for Collecting Speciated and/or Total Nonmethane Organic Compounds Ambient Air Samples Using the ERG:S/NMOC Sampling System
ERG-MOR-047B	Field Procedure for Collecting Ambient Carbonyl Compounds Samples Using the ERG:C Sampling System
ERG-MOR-047C	Field Procedure for Collecting Ambient Carbonyl Compounds Samples Using the ERG:C Sampling System (new timer)
ERG-MOR-049	Standard Operating Procedure for analysis of Semivolatile Organic Compounds (Polynuclear Aromatic Hydrocarbons) Using EPA Compendium Method TO-13A & ASTM D 6209-13
ERG-MOR-057	Standard Operating Procedure for Project Peer Review
ERG-MOR-060	Standard Operating Procedure for PDFID Sample Analysis by Method TO-12
ERG-MOR-061	Standard Operating Procedure for Standard Preparation Using Dynamic Flow Dilution System
ERG-MOR-062	Standard Operating Procedure for Sample Canister Cleaning

TABLE OF CONTENTS (Continued)

Section

ERG-MOR-063	Standard Operating Procedure for the Preparation and Analysis of Ambient Air for Hexavalent Chromium by Ion Chromatography
ERG-MOR-079	Standard Operating Procedure for Sample Login to the Laboratory Information Management System
ERG-MOR-084	Standard Operating Procedure for the Preparation and Extraction of High Volume Quartz and Glass Fiber Filters for Metals by ICP-MS using Method IO 3.1 and FEM Method EQL-0512-201
ERG-MOR-085	Standard Operating Procedure for the Preparation and Extraction of 47mm Filters for Metals by ICP-MS using Method IO 3.1 and FEM Method EQL-0512-202
ERG-MOR-095	Standard Operating Procedure for the Analysis of High Volume Quartz, Glass Fiber Filters, and 47mm Filters for Metals by ICP-MS using Method IO-3.5, FEM Method EQL-0512-201, and FEM Method EQL-0512-202
ERG-MOR-097	Standard Operating Procedure for Manual Integration of Chromatographic Peaks
ERG-MOR-098	Standard Operating Procedure for the Preparation of Monitoring Data for AQS Upload
ERG-MOR-099	Standard Operating Procedure for the Laboratory Information Management System
ERG-MOR-100	Standard Operating Procedure for Carbonyl System Certification
ERG-MOR-105	Standard Operating Procedure for Sample Canister Cleaning using the Wasson TO-Clean Automated System

*These SOPs are not current because they are not in need. Once EPA/State/Local or Tribal agency requests this work, the SOP will be updated and provided to the EPA before work begins.

D Subcontractor QAPPs will be added if they are initiated

LIST OF TABLES

Table

1-1	Program Organization	5 of 8
1-2	QC Responsibilities and Review Functions	7 of 8
3-1	List of Analytical and Support Services.....	3 of 4
4-1	Measurement Quality Objectives for the National Program (UATMP, NATTS, CSATAM, PAMS, NMOC).....	4 of 5
6-1	Data Documentation and Records.....	3 of 6
8-1	EPA Methods and ERG SOPs for each Sampling System.....	1 of 1
9-1	Example of Canister Pressure Check Spreadsheet.....	4 of 16
10-1	VOC GC/FID/MS Operating Conditions	8 of 13
11-1	Summary of SNMOC Quality Control Procedures	4 of 40
11-2	Summary of Air Toxics Canister VOC Quality Control Procedures.....	5 of 40
11-3	BFB Key Ion Abundance Criteria	8 of 40
11-4	Summary of Carbonyl Quality Control Procedures.....	10 of 40
11-5	DFTPP Key Ions and Ion Abundance Criteria	15 of 40
11-6	Internal Standards and Associated PAHs	16 of 40
11-7	Summary of Quality Control Procedures for Analysis of SVOC Samples for PAHs	17 of 40
11-8	Instrument Mass Calibration & Performance Specifications	22 of 40
11-9	Summary of Quality Control Procedures for Metals Analysis.....	24 of 40
11-10	Summary of Quality Control Procedures for Hexavalent Chromium	29 of 40
11-11	2018 SNMOC Method Detection Limits.....	33 of 40
11-12	2018 Air Toxics Method Detection Limits.....	35 of 40
11-13	2018 Carbonyl Method Detection Limits (Underivatized Concentration).....	36 of 40
11-14	2018 PAH Method Detection Limits	37 of 40
11-15	2018 Metals Method Detection Limit.....	39 of 40
11-16	Target MDLs for the NATTS Program	40 of 40
12-1	Preventive Maintenance in ERG Laboratories	1 of 4
13-1	Relative Response Factor Criteria for Initial Calibration of Common Semivolatile Compounds.....	5 of 7
14-1	Critical Supplies and Consumables	2 of 5
15-1	Report Equations.....	6 of 7
15-2	Data Archive Policies	7 of 7

LIST OF TABLES (Continued)

Table

18-1 Qualifier Codes 7 of 11
18-2 Null Codes 9 of 11
18-3 Summary of Quantitation and Detection Limit Flags and Applications 11 of 11

LIST OF FIGURES

Figure

1-1	National Monitoring Programs Organizational Chart	6 of 8
3-1	Duplicate/Collocate and Replicate Analysis Schematic	4 of 4
7-1	NMOC, SNMOC, and 3-Hour Air Toxics Sampling System Components	2 of 10
7-2	VOC/Carbonyl Sampler Training Form	3 of 10
7-3	24-Hour Integrated Air Toxics Sampling System Components	6 of 10
7-4	Carbonyl Sampling System Components	7 of 10
7-5	Hexavalent Chromium Sampling System Components	9 of 10
9-1	Example NMOC COC	2 of 16
9-2	Example Air Toxics COC	3 of 16
9-3	Example ERG LIMS Login Page	5 of 16
9-4	Canister Tag	5 of 16
9-5	Canister Cleanup Log for the ERG Heated Cleaning System	7 of 16
9-6	Canister Cleanup Log for the ERG Unheated Cleanup System	8 of 16
9-7	Example Carbonyl Compounds COC	10 of 16
9-8	Example SVOC Sample COC	12 of 16
9-9	Example Ambient Hexavalent Chromium COC	13 of 16
9-10	Example Metals COC	14 of 16
9-11	ERG Blank COC Record	15 of 16
10-1	Heated Canister Cleanup System Schematic	3 of 13
10-2	Unheated Canister Cleanup System Schematic	5 of 13
10-3	Gas Chromatograph/Mass Spectrometer/FID System	9 of 13
10-4	HPLC System	11 of 13
13-1	Dynamic Flow Dilution Apparatus	4 of 7
15-1	Data Management and Sample Flow Diagram	2 of 7
16-1	ERG Response/Corrective Action Report Form	7 of 7

SYMBOLS AND ABBREVIATIONS

AAC	Atmospheric Analysis and Consulting
AMTIC	Ambient Air Monitoring Technical Information Center
AQS	Air Quality Subsystem
ASTM	American Society for Testing and Materials
BFB	4-Bromofluorobenzene
BLK	Blank
BS/BSD	Blank Spike/Blank Spike Duplicate
CAA	Clean Air Act
CAR	Corrective Action Report
CCB	Continuing calibration blank
CCV	Continuing calibration verification
CFR	Code of Federal Regulations
COC	Chain of Custody
CSATAM	Community Scale Air Toxics Ambient Monitoring
CV	Coefficient of Variation
DFTPP	Decafluorotriphenylphosphine
DNPH	2,4-Dinitrophenylhydrazine
DPR	Daily Performance Check
DQOs	Data Quality Objectives
DUP	Duplicate
DVD	Digital Versatile Disk
EPA	U.S. Environmental Protection Agency
ERG	Eastern Research Group, Inc.
FACA	Federal Advisory Committee Act
FB	Field Blank
FC-43	perfluorotributylamine
FEM	Federal Equivalency Method
FID	Flame Ionization Detector
GC	Gas Chromatograph
GPRA	Government Performance and Results Act
HAPs	Hazardous Air Pollutant(s)
He	Helium
H ₂	Hydrogen

SYMBOLS AND ABBREVIATIONS (Continued)

Hg	Mercury
HPLC	High Performance Liquid Chromatography
HSV	High standard verification
IC	Ion Chromatography
IC	Initial Calibration Standards (for ICP-MS)
ICAL	Initial Calibration
ICB	Initial Calibration Blank
ICP-MS	Inductively Coupled Plasma/Mass Spectrometer
ICSA/IFA	Interference Check Standard A
ICSAB/IFB	Interference Check Standard B
ICV	Initial calibration verification
ID	Identification
IS (or ISTD)	Internal Standard
KED	Kinetic Energy Discrimination
LCS	Laboratory Control Standard
LCV	Low Calibration Verification
LIMS	Laboratory Information Management System
LOQ	Limit of Quantitation
LRB	Laboratory Reagent Blank
m	Meter(s)
MB	Method Blank
MDLs	Method Detection Limit(s)
mL	Milliliter
mm	Millimeter
mM	Millimolar
MQOs	Measurement Quality Objective
MS	Mass Spectrometer
MS/MSD	Matrix Spike/Matrix Spike Duplicate
MUR	Method Update Rule
µg	Micrograms
µg/mL	Micrograms per milliliter
µg/m ³	Microgram per cubic meter
µL	Microliters
µm	Micrometer

SYMBOLS AND ABBREVIATIONS (Continued)

µg/mL	Micrograms per milliliter
N ₂	Nitrogen
NAAQS	National Ambient Air Quality Standard
NATTS	National Ambient Toxics Trends Stations
NELAC	National Environmental Laboratory Accreditation Conference
NELAP	National Environmental Laboratory Accreditation Program
NIST	National Institute of Standards and Technology
NIOSH	National Institute for Occupational Safety and Health
ng	Nanogram
ng/m ³	Nanogram per cubic meter
nm	Nanometer
NMOC	Nonmethane Organic Compounds
NMP	National Monitoring Program
NO _x	Oxides of Nitrogen
O ₃	Ozone
OAQPS	Office of Air Quality Planning and Standards
OD	Outer Diameter
OSHA	Occupational Safety and Health Administration
PAHs	Polycyclic Aromatic Hydrocarbons
PAMS	Photochemical Assessment Monitoring Stations
PCBs	Polychlorinated biphenyls
PDF	Portable Document Format
PDFID	Preconcentration Direct Flame Ionization Detection
PDS	Post digestion spike
PE	Performance Evaluation
POC	Parameter Occurrence Code
ppbC	Parts per Billion as Carbon
ppbv	Parts per Billion by volume
ppmC	Parts per Million as Carbon
psig	Pounds per square inch gauge
PT	Proficiency Testing
PUF	Polyurethane Foam
QA	Quality Assurance
QAPPs	Quality Assurance Project Plan(s)

SYMBOLS AND ABBREVIATIONS (Continued)

QC	Quality Control
QL	Quantitation Limit
RE	Relative Error
RF	Response Factor
RPD	Relative Percent Difference
RRF	Relative Response Factor
RRTs	Relative Retention Times
RSD	Relative Standard Deviation
RT	Retention Time
RTP	Research Triangle Park
SB	Solvent Blank
SIM	Selected Ion Monitoring
SIP	State Implementation Plan
SNMOC	Speciated Nonmethane Organic Compounds
SOPs	Standard Operating Procedure(s)
SQL	Sample Quantitation Limit
SRD	Serial dilution
SRM	Standard Reference Material
SSQC	Second Source Quality Control
STI	Sonoma Technology, Inc.
SVOC	Semivolatile Organic Compounds
TAD	Technical Assistance Document.
TSAs	Technical System Audits
TSP	Total Suspended Particulate
UAM	Urban Airshed Model
UATMP	Urban Air Toxics Monitoring Program
UPS	United Parcel Service of America
UV	Ultraviolet
VOCs	Volatile Organic Compound

DISTRIBUTION LIST

Copies of this plan and all revisions will be provided to:

- Jeff Yane, Work Assignment Manager, U.S. EPA, C404-02, RTP, NC
- Dave Shelow, Delivery Order Manager, U.S. EPA, C339-02, RTP, NC
- Greg Noah, AT QA Coordinator, U.S. EPA, C304-06, RTP, NC

U.S. EPA Regional contacts may obtain a copy of the QAPP by contacting the ERG Program Manager. It is the responsibility of each Regional contact to make copies of the plan for appropriate State personnel or to refer them to ERG Program Manager. The ERG staff working on this contract will receive a copy of this QAPP and all revisions.

PROJECT MANAGEMENT
SECTION 1
PROJECT/TASK ORGANIZATION

1.1 Assignment of Program Personnel

Table 1-1 presents the program organization listing the program assignment and responsible person for each aspect of the Environmental Protection Agency (EPA) National Monitoring Programs (NMP). The program organizational chart is presented in Figure 1-1. All Eastern Research Group, Inc. (ERG) staff working on this contract are provided access to a current electronic copy of this signed, EPA approved Quality Assurance Project Plan (QAPP).

ERG's primary support on this contract includes Nonmethane Organic Compounds (NMOC), Speciated Nonmethane Organic Compounds (SNMOC), Volatile Organic Compounds (VOCs), Polycyclic Aromatic Hydrocarbons (PAHs), Metals, Hexavalent Chromium, and other Hazardous Air Pollutants (HAPs). Subcontracting services are extended by ChromIAn for onsite technical assistance for Photochemical Assessment Monitoring Stations (PAMS) analysis, Sonoma Technology, Inc. (STI) for data validation, Atmospheric Analysis and Consulting, Inc. (AAC) Lab for VOCs by Method TO-17, pesticides/Polychlorinated biphenyls (PCBs), anions, diisocyanates, and 4,4'-methylenedianiline, and RTI International for metals analysis, in the event of a large workload.

ERG is responsible to the client for the work of the subcontractor and choosing subcontractors that meet the applicable requirements for the methods and contracts. The subcontractor should meet the Data Quality Objectives (DQOs) requirements for the appropriate method. ERG shall maintain a record of subcontractor compliance, including documentation of subcontractor's Method Detection Limits (MDLs), QAPPs, etc. Sample analysis will not begin with the subcontractor until MDLs, QAPPs, etc., have been approved by EPA and ERG. Before sample analysis, the subcontractor may perform Proficiency Testing (PT) samples and/or Technical System Audits (TSAs) if they are available through Office of Air Quality Planning and Standards (OAQPS). If such measures are not

available, ERG will request audit reports performed with the subcontract lab and will supply PT audits if requested by the EPA when analysis is contracted with the laboratory.

1.1.1 Program Manager

Ms. Julie Swift, an ERG Vice President, serves as the Program Manager for EPA's NMP. In this role, she has the primary responsibility for understanding program level needs, both EPA's and their clients' (i.e., State, Local, and Tribal agencies). Ms. Swift is ultimately accountable for providing timely, cost effective, and high-quality services that meet the needs of the NMP efforts. Her responsibility is ensuring EPA/client satisfaction by verifying that all components necessary for effective management are in place and active during the contract performance period. Ms. Swift coordinates with the ERG Quality Assurance (QA) Officer, and task leaders to provide EPA/client perspective, communicate technical issues and needs, and ensure the program staff facilitates decisions appropriate to their roles on Contract EP-D-14-030. She prepares budgetary and schedule information and prepares all information for presentation to EPA at scheduled program meetings. As the Program Manager, Ms. Julie Swift is responsible for the technical operation and the quality of the program on a day-to-day basis. She leads the analytical tasks and provides technical direction and support. She assists in the resolution of technical issues and serves as a resource for Task Leaders regarding any project issues. Ms. Swift also performs an overall review of the data that is reported monthly.

1.1.2 Deputy Program Manager

As the Deputy Program Manager, Ms. Laura Van Enwyck assists the Program Manager for EPA's NMP. She assists the Program Manager in all aspects of the technical operation and the quality of the program on a day-to-day basis. She assists the analytical Task Leaders and provides technical direction and support. She assists in the resolution of technical issues and serves as a resource for Task Leaders regarding project issues. Ms. Van Enwyck is also the Carbonyl and HAPs Support Task Leader.

1.1.3 Program Technical Adviser

The Program Technical Adviser, Mr. Dave Dayton assists in the resolution of technical issues. He communicates with ERG management and the technical staff for discussion of real and potential technical problems. He peer reviews draft and final program report products and provides oversight of efforts to evaluate and characterize data.

1.1.4 Program QA Coordinator

Ms. Donna Tedder, the Program and Laboratory QA Coordinator, is responsible for ensuring the overall integrity and quality of project results. Ms. Tedder, or her designee, will do a 10 percent QA review for all sample analyses delivered for reporting by the Program Manager. In the case of subcontracted work, 20 percent of data from subcontractor will be reviewed. The lines of communication between management, the Program QA Coordinator, and the technical staff are formally established and allow for discussion of real and potential problems, preventive actions, and corrective procedures. The key Quality Control (QC) responsibilities and QC review functions are summarized in Table 1-2. On major quality issues, Ms. Tedder reports independently to Ms. Jan Connery, ERG's corporate QA Officer.

1.1.5 Deputy Program QA Coordinator

The Deputy Program QA Coordinator, Ms. Jennifer Nash, is responsible for ensuring the integrity and quality of project results. The Deputy QA Coordinator will assist the Program QA Coordinator with the QA review for sample analyses delivered for reporting by the Program Manager. The major QC responsibilities and QC review functions are summarized in Table 1-2. The Deputy QA Coordinator will work closely with the Program QA Coordinator to ensure the overall quality of the Program.

1.1.6 Task Leaders

ERG Task Leaders are responsible for meeting the project objectives, meeting report schedules, and directing the technical staff in execution of the technical effort for their respective task(s). The Task Leaders will review 100 percent of all sample analyses. The Program QA Coordinator will request 10 percent of that data for review prior to data reporting by the Program Manager. The Task Leaders manage the day-to-day technical activities on delivery orders for this program. They assess and report on the project's progress and results (e.g., recordkeeping, data validation procedures, sample turnaround time) and ensure timely, high-quality services that meet the requirements in this QAPP.

**Table 1-1
 Program Organization**

Program Assignment	Program Personnel Assigned	Phone Number	Email Address
Program Manager	Julie Swift	(919) 468-7924	julie.swift@erg.com
Deputy Program Manager	Laura Van Enwyck	(919) 468-7930	laura.vanenwyck@erg.com
Task Leader - Network Site Coordination	Randy Bower	(919) 468-7928	randy.bower@erg.com
Task Leader - Shipping and Receiving	Randy Bower	(919) 468-7928	randy.bower@erg.com
Task Leader - Air Toxics	Randy Bower	(919) 468-7928	randy.bower@erg.com
Task Leader - Carbonyl Analysis	Laura Van Enwyck	(919) 468-7930	laura.vanenwyck@erg.com
Task Leader - Hexavalent Chromium	Glenn Isom	(919) 468-7940	glenn.isom@erg.com
Task Leader - Metals	Randy Mercurio	(919) 468-7922	randy.mercurio@erg.com
Task Leader - NMOC Analysis	Mitchell Howell	(919) 468-7915	mitch.howell@erg.com
Task Leader - Semivolatiles	Scott Sholar	(919) 468-7951	scott.sholar@erg.com
Task Leader - SNMOC Analysis	Mitchell Howell	(919) 468-7915	mitch.howell@erg.com
Task Leader - PAMS Support *	Julie Swift	(919) 468-7924	julie.swift@erg.com
Task Leader - HAPs Support **	Laura Van Enwyck	(919) 468-7930	laura.vanenwyck@erg.com
Task Leader - Data Characterization	Regi Oommen	(919) 468-7829	regi.oommen@erg.com
Task Leader - Annual Report/QoS Entry	Jaime Hauser	(919) 468-7813	jaime.hauser@erg.com
Program Technical Adviser	Dave Dayton	(919) 468-7883	dave.dayton@erg.com
Program QA Coordinator	Donna Tedder	(919) 468-7921	donna.tedder@erg.com
Deputy QA Coordinator	Jennifer Nash	(919) 468-7881	jennifer.nash@erg.com
Project Administrator	Kerry Fountain	(919) 468-7962	kerry.fountain@erg.com

*Subcontracting support when requested from Chromian and Sonoma Technology, Inc.

**Subcontracting support when requested from AAC and RTI International (miscellaneous HAPs).

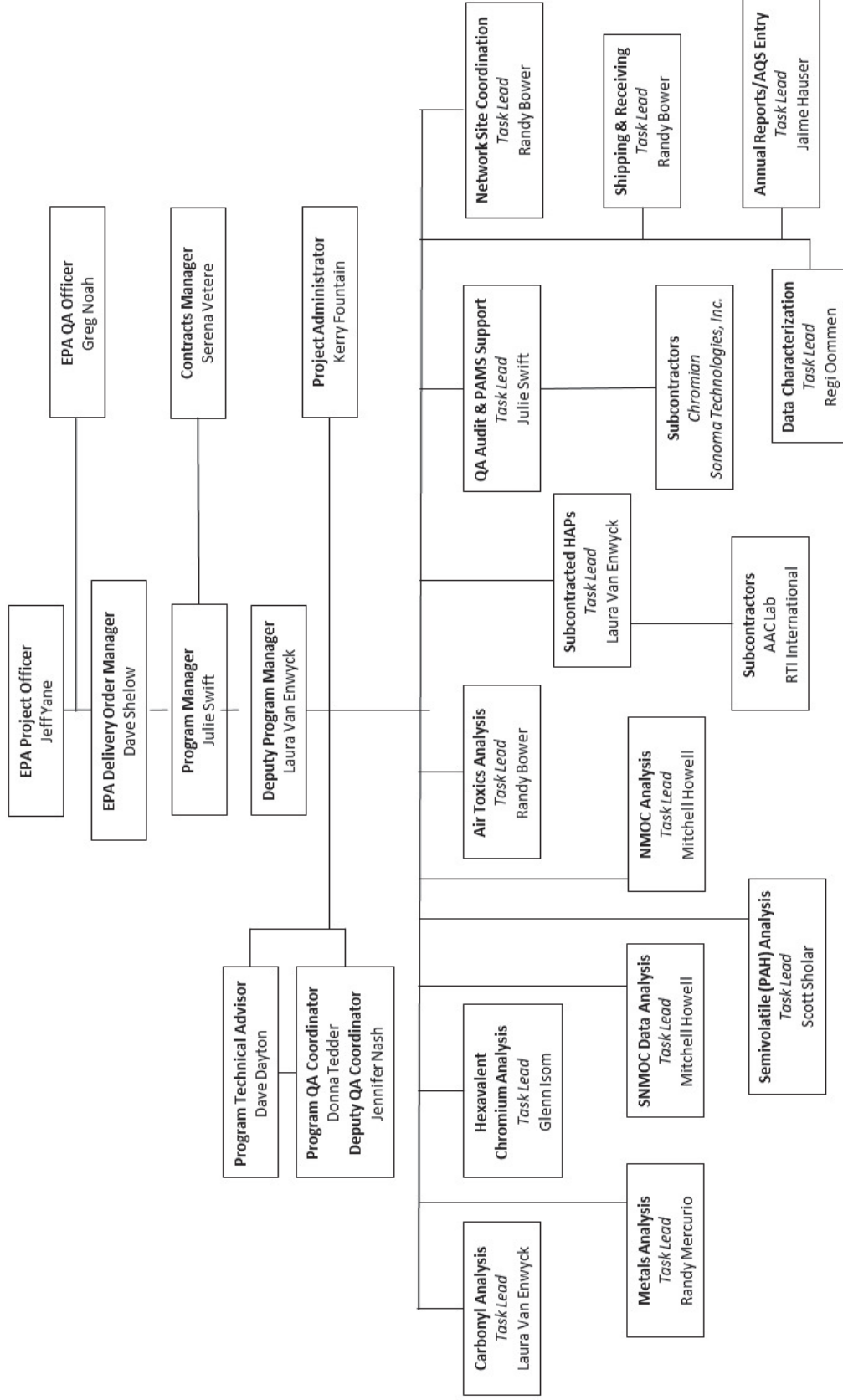

Figure 1-1. National Monitoring Programs Organizational Chart

Table 1-2
QC Responsibilities and Review Functions

Responsible Person	Major Responsibilities
Ms. Julie Swift, Program Manager	<ul style="list-style-type: none"> • Ensure overall timely performance of high quality technical services • Communicate technical issues and needs • Assist in the resolution of technical problems • Track all management systems and tools • Track deliverables and budget performance • Ensure appropriate level of staffing and committed resources exist to perform work • Communicate daily with the EPA/State/Local/Tribal agencies • Ensure data quality • Check information completeness • Review data completeness and quality before reporting to client • Review all reports • Report project performance (budget and deliverables) to EPA at scheduled meetings and in monthly progress reports • Day-to-day management of task leaders
Ms. Laura Van Enwyck, Deputy Program Manager	<ul style="list-style-type: none"> • Assist Program Manager where needed • Ensure overall timely performance of high quality technical services • Communicate technical issues and needs • Assist in the resolution of technical problems • Ensure appropriate level of staffing and committed resources exist to perform work • Communicate with the EPA/State/Local/Tribal agencies • Ensure data quality • Check information completeness • Review data completeness and quality before reporting to client • Day-to-day management of task leaders
Mr. Dave Dayton, Program Technical Adviser	<ul style="list-style-type: none"> • Assist in the resolution of technical problems • Communicate potential technical issues and needs • Review draft and final data reports
Ms. Donna Tedder, Program QA Coordinator	<ul style="list-style-type: none"> • Make QA recommendations • Review QAPP • Audit laboratory • Review QA reports • Evaluate the effect of technical issues on data quality • Review 10% of all data for reporting • Review documentation (SOPs, reports, etc.)

**Table 1-2
QC Responsibilities and Review Functions (Continued)**

Responsible Person	Major Responsibilities
Ms. Jennifer Nash, Deputy Program QA Coordinator	<ul style="list-style-type: none"> • Assist QA Coordinator where needed • Make QA recommendations • Review QAPP • Assist with laboratory audit(s) • Evaluate the effect of technical issues on data quality • Review 10% of all data for monthly reporting • Review documentation (SOPs, reports, etc.)
Task Leader(s)	<ul style="list-style-type: none"> • Review documentation • Review 100% of analytical data generated by analysts • Develop analytical procedures • Propose procedural changes • Train and supervise analysts • Meet task report schedules • Manage day-to-day technical activities • Check information completeness • Review instrument and maintenance log books • Review calibration factor drift • Perform preventive maintenance

SECTION 2

PROBLEM DEFINITION/BACKGROUND

The Clean Air Act (CAA) Amendments of 1990 required EPA OAQPS to set National Ambient Air Quality Standard (NAAQS) for the “criteria” pollutant ozone (O₃). In areas of the country where the NAAQS for O₃ was being exceeded, additional measurements of the ambient NMOC were needed to assist the affected States in developing/revising O₃ control strategies. Measurements of ambient NMOC are important to the control of VOCs that are precursors to atmospheric O₃. Due to previous difficulty in obtaining accurate NMOC concentration measurements, EPA started a monitoring and analytical program in 1984 to provide support to the States. ERG has continuously supported EPA for the NMOC programs since 1984.

In 1987, EPA developed the Urban Air Toxics Monitoring Program (UATMP) to help State, Local and Tribal air monitoring agencies characterize the nature and extent of potentially toxic air pollution in urban areas. Since 1987, several State and local agencies have participated in the UATMP by implementing ambient air monitoring programs. These efforts have helped to identify the toxic compounds most prevalent in the ambient air and indicate emissions sources that are likely to be contributing to elevated concentrations. Studies indicate that a potential for elevated cancer risk is associated with certain toxic compounds often found in ambient urban air⁽¹⁾. As a screening program, the UATMP also provides data input for models used by EPA, State, local and risk assessment personnel to assess risks posed by the presence of toxic compounds in urban areas. The UATMP program is a year-round sampling program, collecting 24-hour integrated ambient air samples at urban sites in the contiguous United States every 6 or 12 days.

The SNMOC program was initiated in 1991 in response to requests by State agencies for more detailed speciated hydrocarbon data for use in O₃ control strategies and Urban Airshed Model (UAM) input.

Title I, Section 182 of the CAA Amendments of 1990 requires States to establish PAMS as part of their State Implementation Plan (SIP) for O₃ nonattainment areas. The rule revises the ambient air quality surveillance regulations to include enhanced monitoring of O₃ and its precursors. The regulations promulgated in 1993 require monitoring of O₃, oxides of nitrogen (NO_x), selected carbonyl compounds, and VOCs. The required monitoring is complex and requires considerable lead time for the agencies to acquire the equipment and expertise to implement their PAMS network. Under the PAMS program, each site may require a different level of support with respect to sampling frequency, sampling equipment, analyses, and report preparation. Presampling, sampling, and analytical activities are performed according to the guidance provided in the Technical Assistance Document (TAD)⁽²⁾, for Sampling and Analysis of Ozone Precursors, 1998 revision. The program objective of PAMS is to provide data that are consistent with the proposed rule for ambient air quality surveillance regulations in accordance with Code of Federal Regulations Title 40, Part 58 (40 CFR Part 58). The ERG team offers site support to any State that needs to set up a PAMS site and/or provide technical help. The specific analytical methodology applicable to the PAMS program will be discussed in this QAPP.

In 1999, EPA expanded this program to provide measurements of additional CAA HAPs to support the Government Performance and Results Act (GPRA). As required under the GPRA, EPA developed a Strategic Plan that includes a goal for Clean Air. Under this goal, there is an objective to improve air quality and reduce air toxics emissions to levels 75 percent below 1993 levels by 2010 in order to reduce the risk to Americans of cancer and other serious adverse health effects caused by airborne toxics.

In 2001, EPA designed a national network for monitoring air toxics compounds present in ambient air entitled the National Ambient Toxics Trends Station (NATTS). The primary purpose of the NATTS network is tracking trends in ambient air toxics levels to facilitate measuring progress toward emission and risk reduction goals. The monitoring network is intended for long term operation for the principle purpose of discerning national trends in air toxics ambient concentrations.

Beginning in 2003/2004, EPA conducted periodic Community Scale Air Toxics Ambient Monitoring (CSATAM) grant competitions. The resultant 1- to 2-year grants are designed to help State, Local, and Tribal communities identify and profile air toxics sources, characterize the degree and extent of local air toxics problems, and track progress of air toxics reduction activities. Grants have been awarded across the United States, in large, medium, and small communities. The ERG team can offer site support and analysis to any agency for the UATMP, NATTS and CSATAM programs.

The data obtained by following this QAPP will be used by EPA, State, Local, Tribal and risk assessment personnel to determine prevalent O₃ precursors and air toxics in the urban air. The data collected from the continuous yearly sites gives the data analyst consistent high quality analytical results. Sampling and analytical uncertainties are determined through this program by performing 10 percent sampling duplicate (or collocated) and analytical replicate samples for each of the ambient air sites.

This QAPP defines the preparation, sampling, laboratory analyses and QA/QC procedures conducted by ERG for EPA's NMP to deliver data of sufficient quality to meet the programs' objectives. Many of these procedures described in this QAPP are based on experiences obtained during previous National Program Studies.

SECTION 3

PROJECT/TASK DESCRIPTION

This section describes the activities performed under each of the major EPA NMP components (NMOC, SNMOC, UATMP, CSATAM, NATTS, and PAMS). ERG dedicates passivated canisters, sampling equipment and expendable sampling media to the program to maintain known quality that meets the program objectives. An applicable measurement methods list is presented in Table 3-1. Sampling and analysis are determined when delivery orders are provided by EPA.

3.1 PAMS, NMOC and SNMOC

The program objective of PAMS is to provide data that are consistent with the proposed rule for Ambient Air Quality Surveillance in accordance with 40 CFR Part 58. The ERG team can offer site support to any State that needs to set up a PAMS site and/or maintain it with technical help. Canister and/or carbonyl samples are collected typically every 3 days by State/Local/or Tribal agency personnel starting on the first of June through the end of September at each of the designated sites.

The NMOC and SNMOC programs require collection of ambient air samples over a 3-hour period. This sample collection period occurs from 6:00 - 9:00 a.m. local time to capture mobile source pollutants during the morning “rush hour” simultaneously with sunrise, which provides the energy necessary for many photochemical reactions. Weekday sampling will be the responsibility of the individual States involved in this program. Canister and/or carbonyl samples are collected by State/Local/or Tribal agency personnel every weekday, typically starting on the first Monday of June through the end of September at each of the designated sites.

ERG can provide sampler, sampler training, and any technical assistance needed throughout the monitoring program. At least one week before each sample collection episode, ERG ships the necessary clean, certified canisters and/or carbonyl cartridges to the site along

with the field chain of custody (COC) forms. The time-integrated ambient samples are then collected and shipped to ERG for analysis.

3.2 UATMP, NATTS and CSATAM

The UATMP program was initiated as an analytical/technical support program focused on ascertaining ambient air levels of organic toxic species. The program has since expanded to provide for the measurement of additional HAPs and the standard sample collection frequency was increased to 1 in 6 days, with some sites continuing at 1 in 12 days.

The NATTS Network is intended for long term operation for the principle purpose of discerning national trends. The primary purpose of the NATTS network is tracking trends in ambient air toxics levels to facilitate measuring progress toward emission and risk reduction goals. The monitoring network is intended to be able to detect a 15 percent difference (trend) between two successive 3-year annual mean concentrations within acceptable levels of decision error. The standard sample collection frequency is 1 in 6 days.

The program objective of the CSATAM Program is designed to help State, Local, and Tribal communities identify and profile air toxics sources, characterize the degree and extent of local air toxics problems, and track progress of air toxics reduction activities. Grants have been awarded across the entire United States, in large, medium, and small communities. Awarded grants fall into one of three categories: community-scale monitoring, method development/evaluation, and analysis of existing data. The sample collection frequency may be 1 in 6 days or 1 in 12 days. Targeted pollutants generally reflect the NATTS core compounds, criteria pollutants, and/or pollutants related to diesel particulate matter.

The ERG team can offer site support and analysis to any State that needs VOC, carbonyl, or other analyses for the PAMS, UATMP, NATTS and CSATAM programs, as shown in Table 3-1. Relevant Standard Operating Procedures (SOPs) are also referenced in the table.

**Table 3-1
List of Analytical and Support Services**

Analysis	Based on Method	SOP (ERG-MOR- XXX)
Analysis		
Total NMOC	TO-12 ⁽³⁾	-060
Speciated NMOC/PAMS Hydrocarbons via GC/FID	TAD for Ozone Precursors ⁽²⁾	-005
VOCs via GC/MS	TO-15 ⁽⁴⁾	-005
Concurrent SNMOC and VOC via GC/MS/FID	TAD for Ozone Precursors ⁽²⁾ /TO-15 ⁽⁴⁾	-005
Carbonyls via HPLC	TO-11A ⁽⁵⁾	-024
PM ₁₀ HAP Metals via ICP-MS	IO-3.5 ⁽⁶⁾ /EQL-0512-201 ⁽⁷⁾ / EQL-0512-202 ⁽⁸⁾	-095
TSP Hexavalent Chromium via IC	ASTM D7614 ⁽⁹⁾	-063
SVOC analysis via GC/MS (SCAN)	TO-13A ⁽¹⁰⁾ / Method 8270D ⁽¹¹⁾	-044***
PAH analysis via GC/MS (SIM)	TO-13A ⁽¹⁰⁾ / ASTM D6209-13 ⁽¹²⁾	-049
PCB/Pesticides via GC *	TO-4A ⁽¹³⁾	*
Anions via IC *	NIOSH 7903 ⁽¹⁴⁾ **	*
VOCs via GC/MS (from cartridge) *	TO-17 ⁽¹⁵⁾	*
Diisocyanates *	OSHA Method 42 ⁽¹⁶⁾	*
4,4'-Methylenedianiline *	NIOSH Method 5029 ⁽¹⁷⁾	*
Site Support		
NMOC/SNMOC	TAD for Ozone Precursors ⁽²⁾	-046***
VOC	TO-15 ⁽⁴⁾	-003 or -021
Carbonyls	TO-11A ⁽⁵⁾	-003 or -047
Hexavalent Chromium	ASTM D7614-12 ⁽⁹⁾	-013
PAMS Technical	NA	NA
PAMS QA	NA	NA
Other Services		
Performance Samples for VOC	TO-15 ⁽⁴⁾	-061
Performance Samples for Carbonyls	TO-11A ⁽⁵⁾	-024
Performance Samples for PAH	TO-13A ⁽¹⁰⁾ / ASTM D6209-13 ⁽¹²⁾	-049
Performance Samples for PM ₁₀ HAP Metals	IO-3.5 ⁽⁶⁾ /EQL-0512-201 ⁽⁷⁾ / EQL-0512-202 ⁽⁸⁾	-095
Performance Samples for TSP Hexavalent Chromium	ASTM D7614-12 ⁽⁹⁾	-063
Sampler Certification for Carbonyls	TO-11A ⁽⁵⁾	-100
Sampler Certification for VOC	TO-15 ⁽⁴⁾	-030
Uniform Calibration Standards	TO-15 ⁽⁴⁾	-061
AQS Data Entry (per pollutant group)	NA	-098
Report Development/Data Characterization	NA	NA

*Will be supplied by subcontractor when analysis is requested.

**NIOSH Method 7903 was replaced with 7906, 7907 and 7908.

***SOP is currently archived but will be updated if needed for sample analysis.

ERG can provide sampler, sampler training, and any technical assistance needed throughout the monitoring program. Canister and/or carbonyl samples are collected by State/Local/or Tribal agency personnel every 6 or 12-days at each of the designated sites. At least one week before each sample collection episode, ERG ships the necessary clean, certified canisters and/or carbonyl cartridges to the site along with the field COC forms. The time-integrated ambient samples are then collected and shipped to ERG for analysis.

ERG then prepares the program data for a final annual report describing sampling and analysis procedures, results, discussion of results, compilation of statistics, and recommendations. To determine the overall precision of analysis for the programs, replicate analyses (10 percent of the total number of samples) are used following the schematic shown in Figure 3-1. After the final data report receives approval by the EPA Project Officer and Delivery Order Manager, ERG distributes the final report to designated recipients. ERG provides the final data summaries to the associated agencies electronically in Excel® and Adobe® formats. ERG staff finalizes and uploads the data into the Air Quality Subsystem (AQS) database.

Figure 3-1. Duplicate/Collocate and Replicate Analysis Schematic

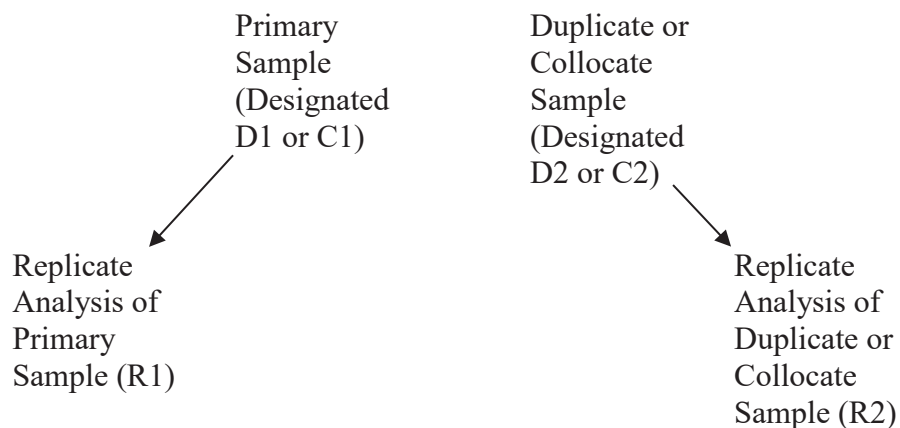

SECTION 4

DATA QUALITY OBJECTIVES AND CRITERIA FOR MEASUREMENT DATA

As ERG performs measurement services only, DQOs for defining a toxics network program are not identified in this QAPP. A well-prepared description of the Measurements Quality Objectives (MQOs) can be found in the TAD for the NATTS Program prepared for EPA in October 2016⁽¹⁸⁾. This section will discuss the MQOs of the ERG laboratory analyses, emphasizing the levels of uncertainty the decision maker is willing to allow/accept from the analytical results. The DQOs for the four programs – NMOC, UATMP, PAMS, and CSATAM – are similar but are not identical. Therefore, the programs are discussed separately.

The NATTS TAD presents the requirements for collecting and reporting data for the NATTS network. Eighteen compounds have been identified as major risk drivers based on a relative ranking performed by EPA and have been designated as NATTS Core or “Tier I” compounds. All other reported compounds, for any NMP, are considered compounds of interest, but do not necessitate the NATTS MQOs. The Tier I compounds are acknowledged throughout this document. ERG exemptions from the NATTS TAD are listed in Appendix A.

Once a DQO is established, the quality of the data must be evaluated and controlled to ensure that data quality is maintained within the established acceptance criteria. MQOs are designed to evaluate and control various phases (sampling, preparation, analysis) of the measurement process to ensure that the total measurement uncertainty is within the range prescribed by the DQOs. MQOs can be defined in terms of the following data quality indicators:

Precision - a measure of mutual agreement between individual measurements performed according to identical protocols and procedures. This is the random component of error.

Bias - the systematic or persistent distortion of a measurement process that causes error in one direction. Bias is determined by estimating the positive and negative deviation from the true value as a percentage of the true value.

Representativeness - a measure of the degree to which data accurately and precisely represent a characteristic of population, parameter variations at a sampling point, a process condition, or an environmental condition.

Detectability - the determination of the low range critical value of a characteristic that a method-specific procedure can reliably discern.

Completeness - a measure of the amount of valid data obtained from a measurement system compared to the amount that was expected to be obtained under correct, normal conditions. Data completeness requirements are included in the reference methods (see References, Section 21).

Comparability - a measure of the level of confidence with which one data set can be compared to another.

Bias has been the term frequently used to represent closeness to “truth” and includes a combination of precision and bias error components. The MQOs listed will attempt to separate measurement uncertainties into precision and bias components. Table 4-1 lists the MQOs for pollutants to be measured in all areas of the UATMP, NATTS, CSATAM, PAMS, and NMOC program.

Analytical Precision is calculated by comparing the differences between Replicate analyses (two analyses of the same sample) from the arithmetic mean of the two results as shown below. Replicate analyses with low variability have a lower Relative Percent Difference (RPD) (better precision), whereas high variability samples have a higher RPD (poorer precision).

$$RPD = \frac{|X_1 - X_2|}{\bar{X}} \times 100$$

Where:

X_1 = Ambient air concentration of a given compound measured in one sample;

X_2 = Concentration of the same compound measured during replicate analysis;

\bar{X} = Arithmetic mean of X_1 and X_2 .

Method precision is calculated by comparing the concentrations of the duplicates/collocates for each pollutant. The Coefficient of Variation (CV) calculation shown below is ideal when comparing paired values, such as a primary concentration versus a duplicate concentration.

$$CV = 100 \times \sqrt{\frac{\sum_{i=1}^n \left[\frac{(p-r)}{0.5 \times (p+r)} \right]^2}{2n}}$$

Where:

- p = the primary result from a duplicate or collocated pair;
- r = the secondary result from a duplicate or collocated pair;
- n = the number of valid data pairs (the 2 adjusts for the fact that there are two values with error).

**Table 4-1
 Measurement Quality Objectives for the National Program (UATMP, NATTS, CSATAM, PAMS, NMOC)**

Program	Reporting Units	Precision from analysis of Replicate Samples (RPD)	Precision (CV) from collection of Duplicate/Collocate Samples	Representativeness	Comparability/ Based on Method	Bias	Completeness	Minimum Detection Limits*
NMOC	ppmC	≤ 10%	≤ 20%	Neighborhood	GC-PDFID EPA Compendium Method TO-12 ⁽³⁾	± 25%	>85%	To be determined upon need
SNMOC	ppbC	≤ 25% ≥ 5x MDL	≤ 25% ≥ 5x MDL	Neighborhood	GC-FID TAD for O ₃ Precursors ⁽²⁾	± 25%	>85%	See Table 11-12
VOC	ppbv	≤ 25% ≥ 5x MDL	For NATTS Tier I compounds, others ≤ 15%, others ≤ 25% ≥ 5x MDL	Neighborhood	GC-FID/MS EPA Compendium Method TO-15 ⁽⁴⁾	± 25%	>85%	For NATTS Tier I, see NATTS TAD Table 4.1-1 Others, see Table 11-13
Carbonyls	ppbv	≤ 10% ≥ 0.5 µg/cartridge	For NATTS Tier I compounds, others ≤ 15%, others ≤ 20% ≥ 0.5 µg/cartridge	Neighborhood	HPLC EPA Compendium Method TO-11A ⁽⁵⁾	± 25%	>85%	For NATTS Tier I, see NATTS TAD Table 4.1-1 Others, see Table 11-14
Metals	ng/ per cubic meter (ng/m ³)	≤ 20% ≥ 5x MDL	For NATTS Tier I compounds, others ≤ 15%, others ≤ 20% ≥ 5x MDL	Neighborhood	ICPMS IO-3.5 ⁽⁶⁾ /EQL-0512-201 ⁽⁷⁾ / EQL-0512-202 ⁽⁸⁾	± 25%	>85%	For NATTS Tier I, see NATTS TAD Table 4.1-1 Others, see Table 11-16
Hexavalent Chromium	ng/m ³	≤ 20% for conc. > 5x MDL	≤ 20%	Neighborhood	IC-UV Detector ASTM D7614-12 ⁽⁹⁾	± 25%	>85%	0.0038 ng/m ³

*For NATTS Tier 1 compounds, minimum detection limits are listed in the NATTS TAD.

**Table 4-1
 Measurement Quality Objectives for the National Program (UATMP, NATTS, CSATAM, PAMS, NMOC) (Continued)**

Program	Reporting Units	Precision from analysis of Replicate Samples (RPD)	Precision (CV) from collection of Duplicate/Collocate Samples	Representativeness	Comparability/ Based on Method	Bias	Completeness	Minimum Detection Limits
Semivolatiles	micro-gram/m ³ (µg/m ³)	≤ 10% for conc. ≥ 0.5 µg/mL	For NATTS Tier I compounds, ≤15%, others ≤ 20% for conc. ≥ 0.5 µg/mL	Neighborhood	GC/MS EPA Compendium Method TO-13A ⁽¹⁰⁾ and ASTM D6209-13 ⁽¹²⁾ , (or SW-846 Method 8270D ⁽¹¹⁾)	± 25%	>85%	For NATTS Tier I, see NATTS TAD Table 4.1-1 Others, see Table 11-15
PCB/ Pesticides	ng/m ³	≤ 15%	≤ 15%	Neighborhood	GC EPA Compendium Method TO-4A ⁽¹³⁾	± 25%	>85%	To be determined upon need
Anions	ppbv	≤ 15%	≤ 15%	Neighborhood	IC NIOSH Method 7903 ⁽¹⁴⁾	± 25%	>85%	To be determined upon need
VOCs via cartridge	ppbv	≤ 15%	≤ 15%	Neighborhood	GC/MS EPA Compendium Method TO-17 ⁽¹⁵⁾	± 25%	>85%	To be determined upon need
Diisocyanates	µg/m ³	≤ 15%	≤ 15%	Neighborhood	HPLC OSHA Method 42 ⁽¹⁶⁾	± 25%	>85%	To be determined upon need
4,4'-Methylene-dianiline	µg/m ³	≤ 15%	≤ 15%	Neighborhood	HPLC NIOSH Method 5029 ⁽¹⁷⁾	± 25%	>85%	To be determined upon need

*For NATTS Tier 1 compounds, minimum detection limits are listed in the NATTS TAD.

SECTION 5

SPECIAL TRAINING REQUIREMENTS/CERTIFICATION

The activities of EPA's NMP are performed using accepted EPA, National Institute for Occupational Safety and Health (NIOSH), and Occupational Safety and Health Administration (OSHA) sampling and analytical protocols for the field sampling training personnel and analytical laboratory staff.

5.1 Field Activities Training Personnel

Field activities training personnel involved in this project have over 30 years of experience in the duties they will be performing in the field. The training of ERG field activities personnel is recorded in the ERG Training Records files. Special certification is not needed for an operator to set up the sampling systems. Each State should document and record the training of their personnel on the field testing procedures provided by ERG.

The States' field testing staff will be subject to on-site surveillance by EPA. ERG's Task Leader will provide appropriate corrective action enforcement, if necessary, for the ERG personnel setting up the sampling equipment and the field testing staff. ERG provides on-the-job training in the field on sampler use and maintenance, for supervisors and field site operators. The appropriate SOPs used during training are presented in Appendix C. ERG does not provide SOPs for sampling systems that are not maintained by ERG. Sampling System Training forms used during operator training in the field is presented in Figure 7.2 for VOC/Carbonyl and Carbonyl samplers. The forms will only be provided when new site personnel are trained on the sampling systems. After training is completed and signed in the field, the yellow copy is retained for site records. The original copy is scanned in the laboratory and stored by the QA coordinator.

The sampling equipment for monitoring sites may be inside a sampling building or outside. There are no hazards inherent to the samplers and no special safety training or equipment will be required. Site hazards should be addressed on a site-by-site basis by the site

operator's SOPs. All ERG field activities training personnel will follow the ERG Corporate Health and Safety Plan.

5.2 Analytical Laboratory Personnel

Analytical laboratory personnel involved in this project have been trained in their tasks and have up to 30 years of experience in the duties they will be performing in the analytical laboratory. Training of ERG laboratory personnel is recorded in ERG Training Records in an Excel® database and filed as a hardcopy. It is the responsibility of the trainee and the laboratory's Project Administrator to keep the Training Records up to date. It is the responsibility of the Program Manager and Quality Assurance Coordinator to approve analysis training records. Normal training and overview is provided to the analyst by the Task Leader for that analysis. Technical training includes general techniques and specific training based on the appropriate SOP, method, and program QAPP. The trainee first observes the task, then performs the task under supervision of the trainer, then performs the task under supervision of the Task Lead (if the Task Lead is not the trainer). After training, demonstration of each personnel's ability to perform an analytical task involves repeated measurements of a standard, which is described in more detail in each analytical SOP. Currently, no special certifications are needed for the analysis of the ambient samples received for these programs.

ERG maintains appropriate SOPs for each of the analytical methods. These SOPs are presented in Appendix C. All SOPs document equipment and/or procedures required to perform each specific laboratory activity. Laboratory staff will be subject to on-site surveillance by the QA staff and periodic performance evaluation (PE) samples. These audits will assure the program that the appropriate analysts and analytical procedures are being used. The samples involved in this program are generated by monitoring air emissions. Health and Safety training is performed annually. The laboratory personnel will adhere to the ERG Corporate Health and Safety manual.

SECTION 6

DOCUMENTATION AND RECORDS

The EPA NMP are a collection of individual ambient monitoring programs that generate documents and records that need to be retained/archived. All ERG staff working on this contract are provided access to a current electronic copy of this signed, EPA approved QAPP. Annually, the staff is required to sign a form to document that they read and understood the QAPP. In this QAPP, ERG's reporting package (information required to support the analytical results) includes all data required to be collected as well as support data deemed important by ERG/EPA.

6.1 Data Management

ERG has a structured records management system that allows for the efficient archive and retrieval of records. Each laboratory archives the data from the computer systems onto the shared network drive. The laboratory paper copies of all analyses are stored on site in a secured temperature-controlled area for up to five years after the close of the contract. The laboratory also archives the data in the Laboratory Information Management System (LIMS) data server which is backed up weekly, monthly, and biannually. The Program Manager has final authority for the storage, access to, and final disposal of all records kept for the EPA NMP.

6.2 Preliminary Monthly Data Reports

Preliminary monthly summary data reports are sent in Adobe Portable Document Format (PDF) and Excel formats to EPA and appropriate State/Local/Tribal agencies. The monthly data reports will include analytical results, associated MDL, final units, associated QC samples, and data qualifiers.

6.3 Quarterly QA Report

A QA report for each type of data analysis is sent to EPA and appropriate State/Local/Tribal agencies on a quarterly basis in the form of control charts including initial calibration verifications, continuing calibration verifications, method blanks, initial calibration blanks, continuing calibration blanks, and blank spikes.

6.4 Annual Summary Reports Submitted to EPA

Hard copies of the final report are presented to EPA contacts at the end of the sampling period. State/Local/Tribal agencies receive electronic copies (i.e., PDF). The final report is submitted for the data collected from January 1 to December 31 of the previous year. The report can contain the following information:

- Names of participating sites and corresponding metadata information, including city name, location and the AQS codes;
- Description of the sampling and analytical methodologies used by the laboratory;
- Completeness of the monitoring effort for each site;
- Background information on the methodology used to present and analyze the data;
- General combined and individual site summary of the year's results;
- Discussion of different trends for the select HAPs chosen for analysis;
- Risk screening evaluations using toxicity factors (e.g., UREs or RfCs);
- Variability analysis (intra-site and seasonal comparisons);
- Pollution roses to determine predominant direction for select compounds;
- Discussion of precision and accuracy and other prevalent QC concerns; and
- Yearly discussions of conclusions and recommendations.

If corrections are needed after the final report is presented to EPA, the report is easily retrieved, and corrections are sent to all relevant personnel.

6.5 Records and Supporting Data

All raw data required for the calculation of air toxics concentrations, submission to the EPA/AQS database, and QA/QC data are collected electronically or on data forms that are included in the field and analytical methods sections. All hardcopy information is filled out in indelible ink. Corrections are made by inserting one line through the incorrect entry, initialing the correction (ERG maintains a signature log), and placing the correct entry alongside the incorrect entry, if this can be accomplished legibly, or by providing the information on a new line. Table 6-1 presents the location of the data records for field and laboratory operations stored at the ERG laboratory.

Table 6-1. Data Documentation and Records

Item	Record	Short Term Location Storage	Long Term Location Storage
Field Operations			
Sampling System Training	Sampling System Training Form	ERG	Copy scanned and hardcopy stored by ERG
COC	ERG COCs	Field gets “pink” copy, ERG gets “yellow” and “white” copy	Copy scanned and stored on ERG LIMS
QC Sample Records (field blanks, duplicate/ collocated, sample integrity, etc.)	COC	Field	Copy scanned and stored on ERG LIMS
General Field Procedures	COC	Field	Copy scanned and stored on ERG LIMS
Laboratory Records			
Sample Prep Data	Bench sheets	Hardcopy filed, LIMS, shared network drive	Hardcopy archived, LIMS, shared network drive

Table 6-1. Data Documentation and Records, Continued

Item	Record	Short Term Location Storage	Long Term Location Storage
Laboratory Operations			
Sample Management Records (sample receipt, handling, storage, etc.)	COCs	LIMS, with sample analytical data	LIMS, with sample analytical data
Test Methods	SOPs	Hardcopy filed, shared network drive	Shared network drive
QA/QC Reports (General QC records, MDL information, calibration, etc.)	Individual records for each analysis	Hardcopy filed, shared network drive	Hardcopy archived, shared network drive
Corrective Action Reports	Individual records for each analysis	Hardcopy filed, a copy in data package if appropriate	All copies archived
Data Reduction, Verification, and Validation			
Electronic Data (used for reporting and AQS)	Excel [®] and Access [®]	Shared network drive	Shared network drive

6.5.1 Notebooks

ERG issues laboratory notebooks upon request. These notebooks are uniquely numbered and associated with the laboratory personnel. Notebooks are archived upon completion for at least 5 years from the end of a project. Although LIMS data entry forms are associated with all routine environmental data operations, the notebooks can be used to record additional information about these operations. The procedures for maintaining notebooks are presented in *SOP for Maintaining Laboratory Notebooks* (ERG-MOR-039) in Appendix C.

Field Notebooks - Field notebooks are the responsibility of EPA, States, Local or Tribal agencies as ERG is not responsible for the collection of samples.

Laboratory Notebooks - Notebooks are associated with general procedures such as calibration of analytical balances, standard preparation logs, etc., used in this program.

Logbooks are generated and bound by the laboratory's Project Administrator for procedures such refrigerator/freezer temperatures, canister cleaning, etc. Logbook pages have a unique version identifier. Upon completion, logbooks are archived indefinitely, at a minimum at least 5 years from the end of a project.

6.5.2 Electronic Data Collection

To reduce the potential for data entry errors, automated systems are utilized (where appropriate) and record the same information that is found on data entry forms. In order to provide a back-up, hardcopy data collected on an automated system will be stored for 5 years after the end of the closed EPA NMP contract.

6.6 Data Reporting Package Archiving and Retrieval

In general, all the information listed above will be retained for at least 5 years from the date of the end of the closed contract with EPA. However, if any litigation, claim, negotiation, audit, or other action involving the records has been started before the expiration of the 5-year period, the records will be retained until completion of the action and resolution of all issues which arise from it, or until the end of the regular 5-year period, whichever is later. The long-term storage is on-site in a locked climate-controlled file room with limited-access. The Project Administrator keeps a record of documents entering and leaving long-term storage. Access to the facility storage area is limited to authorized personnel only.

6.7 Quality System Document Control

To ensure the use of the most current version of quality system documents, all quality documents (QAPP, SOPs, etc.) generated at the ERG Laboratory must be uniquely identified. Original documents shall include the date of issue, revision number, page number, the total number of pages, and appropriate signatures. Copies of quality documents shall be controlled and include the date of issue, revision number, page number, the total number of pages, and copy

control number. When an original quality document is updated, the QA Coordinator or designee will ensure that the copy documents are also updated, and old versions are destroyed. During the project, revised QAPPs will be circulated to appropriate EPA personnel and ERG's laboratory staff. For copies of documents out of the laboratory's control, a stamp or watermark stating "Uncontrolled" or "Draft", if applicable, will be applied. Each approved QAPP will be posted on EPA's Ambient Air Monitoring Technical Information Centers (AMTIC) Website without the associated SOPs.

MEASUREMENT DATA ACQUISITION
SECTION 7
SAMPLING PROCESS DESIGN

Sampling procedures for the NMOC, SNMOC, UATMP, NATTS, and CSATAM programs are discussed in this section. ERG provides site-specific support for the PAMS and HAPs sampling. All parameters listed in this section are necessary for the sampling systems listed below. ERG is not responsible for the collection of samples nor the design of these programs.

7.1 NMOC and SNMOC Canister Samplers

Sampling for NMOC and SNMOC takes place each workday from the beginning of June to the end of September at designated NMOC and SNMOC sites from 6:00 a.m. to 9:00 a.m. local time. Sampling procedures have been discussed in detail in other documents. ^(1, 2) Figure 7-1 is a diagram of the ERG sampling system used for collecting the ambient air samples. Clean, evacuated passivated stainless-steel canisters are shipped daily from ERG's Research Triangle Park (RTP) Laboratory to the NMOC and SNMOC sites. Canisters are connected to the sampling system by local operators. The digital timer automatically activates the pump and solenoid valve to start and stop sample collection. The pump pressurizes air samples during the sampling period to about 15 pounds per square inch gauge (psig), and the flow control valve (variable orifice) ensures a constant sampling rate over the 3-hour period. A 2-micron stainless steel filter is installed in the sampling line to remove particulate from the ambient air that may damage or plug the variable orifice. The sample probe inlet is positioned from 2 to 10 meters (m) above ground level.

ERG installs the sampling systems at the site location and trains associated local operators on site. Operator training is documented on the Sampler Training Form (Figure 7-2). It is the responsibility of the local operators to operate the sampling apparatus and complete the field sample COC form that ERG supplies with each canister. ERG staff maintain telephone

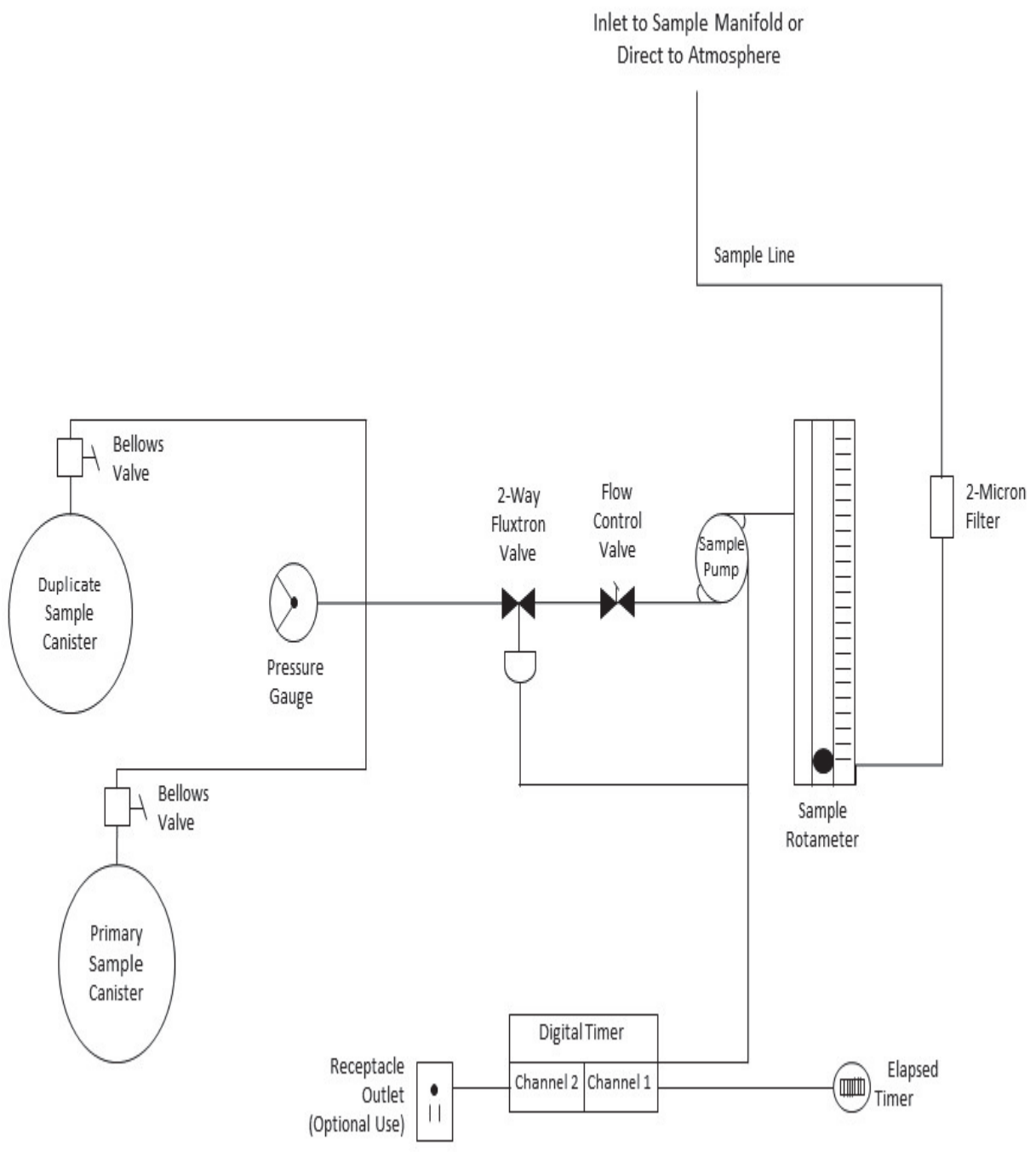

Figure 7-1. NMO, SNMO, and 3-Hour Air Toxics Sampling System Components

VOC/Carbonyl Sampling System Training

3-2018

Installation Date: _____ Trainer: _____
Site ID: _____ Copy of SOP on Site: (Y/N) _____
Installed Sampler ID #: _____ Replaced Sampler ID #: _____
Time Set: _____ Carb Line Replaced: (Y/N) _____
Timer Set: _____ VOC Line Replaced: (Y/N) _____

Trainee:	Signature:	Date:
_____	_____	_____
_____	_____	_____
_____	_____	_____
_____	_____	_____
_____	_____	_____
_____	_____	_____

NOTES:

ERG assumes no personal and/or property liability realized by the user from the use of ERG provided equipment. The user, by virtue of accepting the ERG equipment for use, undertakes any/all personal and/or property liabilities that could be associated with its use (including operational, housing, and/or safety).

Figure 7-2. VOC/Carbonyl Sampler Training Form

and/or email contact throughout the project to provide whatever assistance is needed to resolve technical issues that arise during the sampling program.

For a 3-hour ambient air sample, NMOC, SNMOC, and VOC measurements may all be performed from the same canister. Refer to Section 7.2 for sampler certification.

7.2 VOC and Carbonyl 24-Hour Samplers

ERG provides the sites with a sampling schedule each year. A total of 31 sampling days will be scheduled per site for a 12-day sampling schedule and 61 sampling days for the 6-day sampling schedule. Days for duplicate (or collocated) sampling will also be designated. The 2018 Sampling calendar is presented in Appendix B.

Prior to installation of an ERG sampler at a UATMP, NATTS or CSATAM site, the sampler is certified at the ERG laboratory. Certification establishes that the system is functioning correctly and provides for the appropriate level of specified compound recovery and cleanliness. To certify the sampling system, cleaned, humidified nitrogen (N₂) is first flushed through the sampler for at least 24 hours to remove the potential for organic contaminants in the system. The canister sub-system of the samplers is then challenged with a mixture of representative VOCs at known concentrations to qualify the sampler recovery characteristics (as recommended in the NATTS TAD)⁽¹⁸⁾. A Sampling System Blank is then collected in canisters and on carbonyl cartridges and is analyzed based on EPA Compendium Method TO-15⁽⁴⁾ and Method TO-11A⁽⁵⁾ to verify that the system meets the required cleanliness criteria and can produce non-biased samples (as required by the NATTS TAD⁽¹⁸⁾). These results are documented in a file specific to each sampler by system identification number. The certification procedures are presented in *SOP for Canister Sampling System Certification Procedures* (ERG-MOR-030) and *SOP for Carbonyl System Certification Procedures* (ERG-MOR-100) in Appendix C.

Integrated ambient air samples are collected in 6-liter passivated stainless-steel canisters (SUMMA, Silonite[®], TO-Can, etc.) and carbonyl cartridges for a 24-hour period beginning at

midnight for each scheduled sampling event. Carbonyl cartridges are shipped cold and the cleaned, quality-controlled canisters are shipped under vacuum to the site from the ERG laboratory. After sampling, the final pressure in the canister should ideally be between 2 to 8 inches of Mercury (“Hg) vacuum. The sampling assembly for the sample collection is shown in Figure 7-3.

The physical mechanism for filling the canister is vacuum displacement. The vacuum pump shown in Figure 7-3 is used to purge the mass flow controller and the sample inlet lines. A second vacuum pump is used to draw ambient air through the carbonyl sampling probe and cartridges. Ozone is removed from the sample stream prior to collection on the 2,4-Dinitrophenylhydrazine (DNPH) sampling cartridge. To accomplish O₃ removal, the sample stream (ambient air) is drawn through a potassium iodide-coated denuder O₃ scrubber which is an internally integrated component of the sampler. Carbonyl sampling can occur at sites at the same time as the canister samples are taken or on separate samplers.

7.3 Carbonyl Only 24-Hour Samplers

Carbonyl samples are collected using DNPH-impregnated sampling cartridges with an integrated sampling system (e.g., vacuum pump, capillary critical orifices, and O₃ scrubbers), shown in Figure 7-4. Ambient air is drawn through the cartridges via a separate sampling probe. A potassium iodide-coated denuder O₃ scrubber is an internally integrated component of the sampler that removes O₃ from the sample stream prior to the DNPH sampling cartridge.

Prior to installation of an ERG sampler at a UATMP, NATTS or CSATAM site, the sampler is certified at the ERG laboratory. Certification establishes that the system is functioning correctly and provides for the appropriate level of cleanliness. To certify the sampling system, cleaned, humidified N₂ is first flushed through the sampler for at least 12 hours to remove the potential contaminants from the system. A Sampling System Blank and a reference blank are then collected on carbonyl cartridges and are analyzed based on EPA

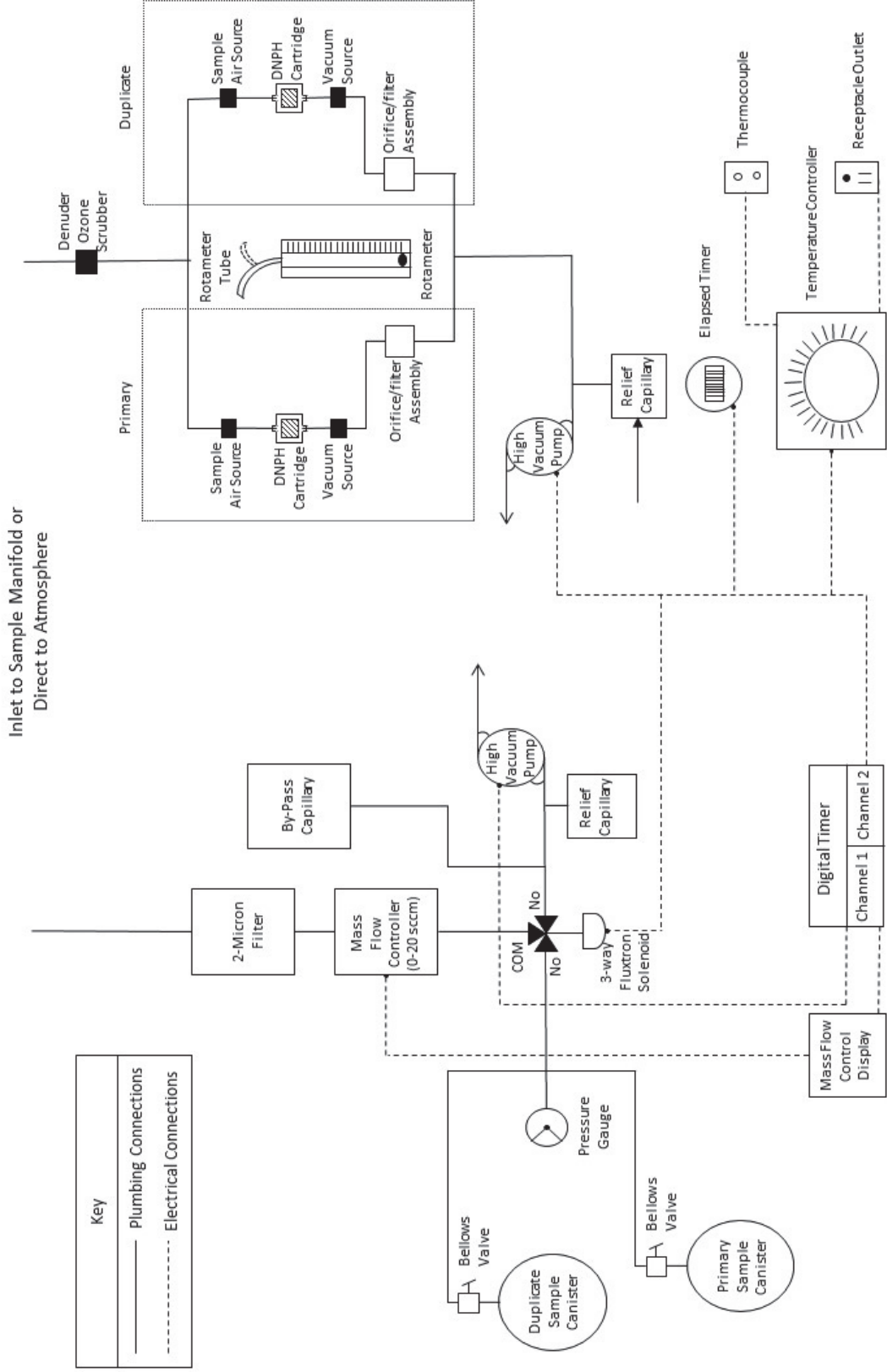

Figure 7-3. 24-Hour Integrated Air Toxics Sampling System Components

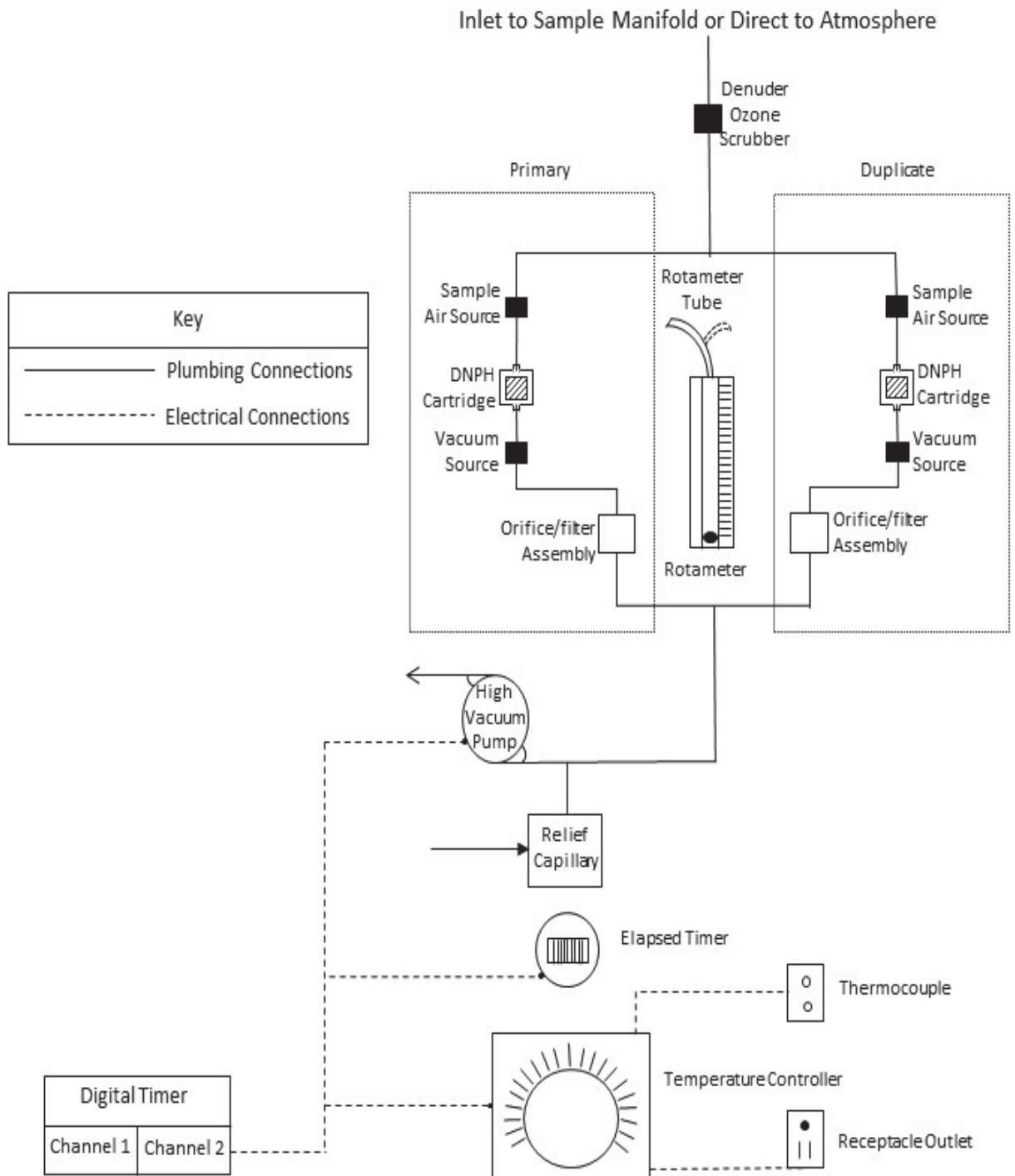

Figure 7- 4. Carbonyl Sampling System Components

Compendium Method TO-11A⁽⁵⁾ to verify that the system meets the required cleanliness criteria and can produce non-biased samples as required by the NATTS TAD⁽¹⁸⁾. These results are documented in a permanent file specific to each sampler by system identification number. The certification procedure is presented in the *SOP for Carbonyl Sampling System Certification* (ERG-MOR-100) in Appendix C.

A total of 31 sampling cartridges for a 12-day sampling schedule and 61 sampling cartridges for a 6-day sampling schedule will be collected and analyzed per site. Duplicate (or collocated) samples and field blanks will be collected monthly and are designated in the 2018 Sampling calendar presented in Appendix B.

7.4 Hexavalent Chromium Samplers

Sodium bicarbonate-impregnated cellulose filters are connected to the Hexavalent Chromium sampler as shown in Figure 7-5 and ambient air is drawn through the filters through a glass sampling probe using Teflon sampling lines. Prepared filters are shipped to each site for the hexavalent chromium sampling. ERG ships the bicarbonate-impregnated sodium cellulose filters to each site in coolers (chilled with blue ice packs). The samples are collected for a 24-hour period. Disposable polyethylene gloves are used by the field operators when handling the filters to reduce background contamination. After sampling, the filters are removed from the sampling apparatus, sealed, and returned to the ERG laboratory in the coolers and ice packs in which they were received. Additional qualifying information for the hexavalent chromium sampling and analysis techniques is presented in the American Society for Testing and Materials (ASTM) D7614-12⁽⁹⁾ method and specific details are provided in ERG's *SOP for the Preparation and Analysis of Ambient Air for Hexavalent Chromium by Ion Chromatography* (ERG-MOR-063) presented in Appendix C.

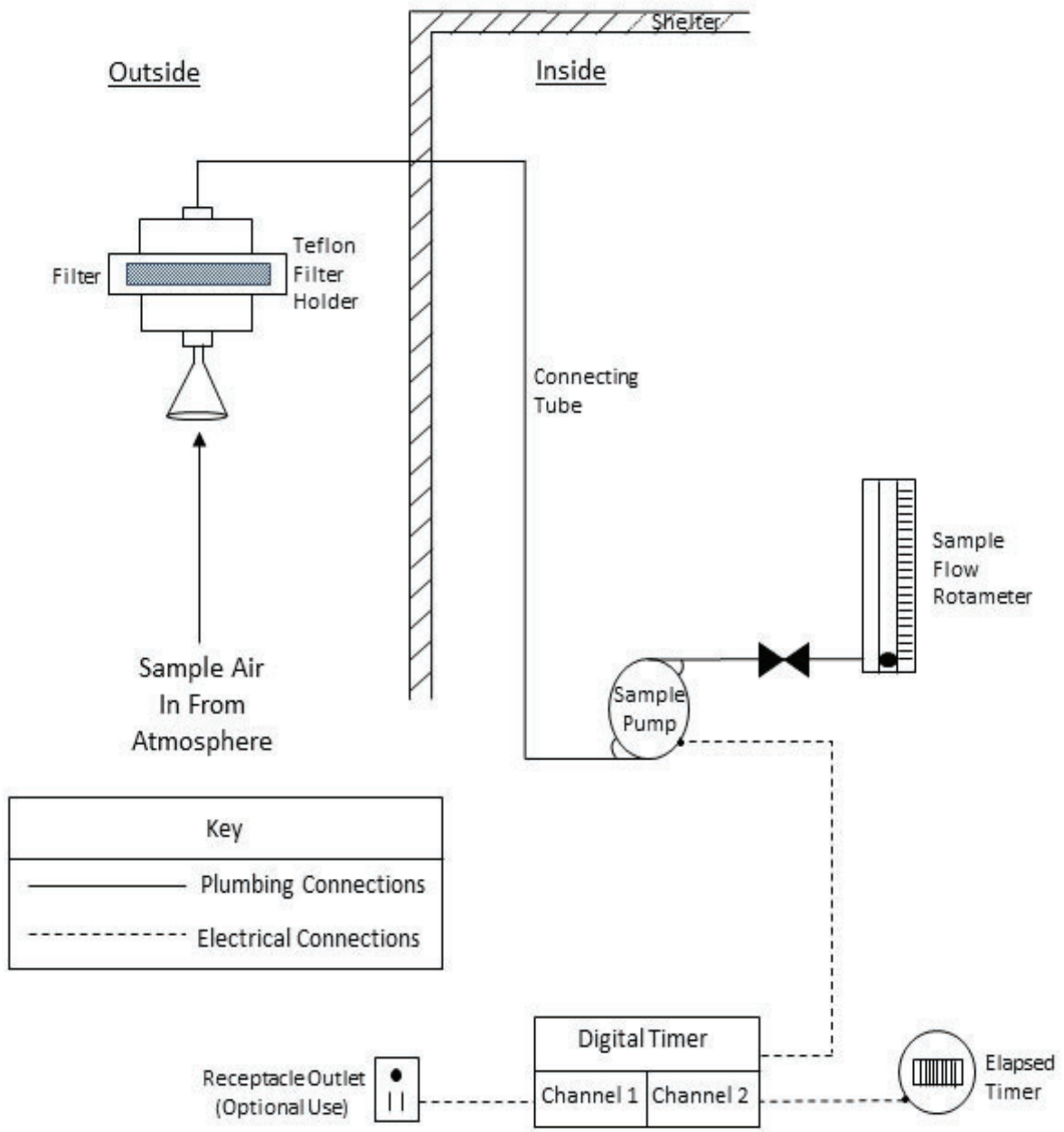

Figure 7-5. Hexavalent Chromium Sampling System Components

7.5 PAMS Sampling

PAMS sampling is performed completely by the PAMS sites in accordance with the Ozone Precursors TAD⁽²⁾ with ERG only supplying support as requested (e.g., sampling system and training for automated gas chromatograph (GC) systems). ERG ships cleaned canisters and prepared carbonyl cartridges to the PAMS sites on the appropriate schedule to support the sampling program, and the samples are shipped to the ERG laboratory for analysis. The need for support of automated GC systems is site specific.

7.6 HAPs Sampling

HAPs sampling is performed by the sites in accordance with the methods listed in Table 3-1, with the exception of hexavalent chromium sampling (see Section 7.4). ERG provides the hexavalent chromium sampling systems and media and receives the samples from the sites for analysis.

SECTION 8
SAMPLING METHOD REQUIREMENTS

The sampling methods that are used in this program are described in this Section. Since there are four separate sampling systems and subsequently four separate analytical techniques, each of the sampling methods is different.

The SOPs for each method are reviewed annually and updated as necessary. The QA Coordinator, Program Manager and Writer/Editor will review, sign and date SOPs before distributing to the laboratories satellite file areas. The previous copies will be replaced with the revised edition. The appropriate users are notified of the updated procedure. The original, and all previously revised edits, are stored in an archive file maintained by ERG’s Project Administrator.

As ERG is not responsible for actual execution of the field sampling in this program, the ERG SOPs list general sampling guidelines needed for the NMOC, UATMP, Carbonyl, and Hexavalent Chromium sampling. Table 8-1 identifies the different methods and SOP numbers for operation of each type of sampler ERG provides. Some HAPs sampling is not addressed in the NMP Support contract (Metals, PAHs, etc.), and are not discussed in this QAPP.

Table 8-1
EPA Methods and ERG SOPs for each Sampling System

Sampling System	Based on Applicable Method	ERG SOP Number
NMOC	EPA Compendium Method TO-12 ⁽³⁾	ERG-MOR-046
VOC	EPA Compendium Method TO-15 ⁽⁴⁾	ERG-MOR-003
Carbonyl	EPA Compendium Method TO-11A ⁽⁵⁾	ERG-MOR-047
Hexavalent Chromium	ASTM D7614-12 Method ⁽⁹⁾	ERG-MOR-013

SECTION 9

SAMPLE HANDLING AND CUSTODY REQUIREMENTS

Similar sample custody procedures are followed for all monitoring programs. However, program-specific differences exist because the analytical requirements for the programs vary. As these activities are conducted under one EPA contract, United Parcel Service of America (UPS) with Overnight Delivery will handle all shipping to and from the sites. Unless specified below, samples taken in the field should not require any extra special precautions for shipping.

The Shipping and Receiving Task Leader will ensure that sample media that leaves and field samples that are received in the laboratory follow all procedures listed in this QAPP and the individual SOPs. The Task Leader will also advise the Project Manager of any issues or obstacles regarding sample shipping, receipt, login and storage. The sample custodian working under the Shipping and Receiving Task Leader will ship sample media to the field and receive custody of samples, complete COC receipt information, document sample receipt, and enter COC information into LIMS to create a work order.

9.1 Canister Sample Custody

9.1.1 Canister Custody

A color-coded, three-copy canister sample COC form (Figures 9-1 and 9-2) is shipped with each 6-liter canister for the NMOC, SNMOC, UATMP, NATTS, CSATAM, or PAMS sites. If duplicate or collocated samples are to be taken, two canisters and two COC forms are sent in the shipping container(s) to the site. When a sample is collected, the site operator fills out the form per the instructions in the on-site notebook. The site operator detaches the pink copy to be retained on-site and sends the remaining copies with the canister in the shipping container to ERG's laboratory.

		ERG Lab ID # _____
601 Keystone Park Drive, Suite 700, Morrisville, NC 27560 NMOC SAMPLE CHAIN OF CUSTODY		
Lab Pre-Sampling	Site Code: _____ City/State: _____ AQS Code: _____ Collection Date: _____ Options NMOC (Y/N): _____ SNMOC (Y/N): _____ TOXICS (Y/N): _____	Canister Number: _____ Lab Initial Can. Press. ("Hg): _____ Date Can. Cleaned: _____ Cleaning Batch # : _____ Duplicate Event (Y/N): _____ Duplicate Can # : _____
Field Setup	Operator: _____ Sys. #: _____ Setup Date: _____ Field Initial Can. Press. ("Hg): _____	Rotameter Setting: _____ Elapsed Timer Reset (Y/N): _____ Canister Valve Opened (Y/N): _____
Field Recovery	Recovery Date: _____ Field Final Can. Press. (psig): _____	Sample Duration (3 or 24 hr): _____ Elapsed Time: _____ Canister Valve Closed (Y/N): _____
Lab Recovery	Received by: _____ Date: _____ Status: Valid Void (Circle one) If void, why: _____	Lab Final Can. Press. (psig): _____
NMOC	Analyst: _____ Date: _____ NMOC Instrument: _____ Inj. 1 (AC): _____ (ppmC): _____ Inj. 2 (AC): _____ (ppmC): _____ Inj. 3 (AC): _____ (ppmC): _____ Average AC: _____ Standard Dev. (AC): _____ Average Conc. (ppmC): _____ Standard Dev. (ppmC): _____	Database entry by: _____ Date: _____ Batch ID _____
SNMOC Option	Analyst: _____ Batch ID _____	Date: _____
Toxics Option	Analyst: _____ Batch ID _____	Date: _____

Comments: _____

White: Sample Traveler

Canary: Lab Copy

Pink: Field Copy

Figure 9-1. Example NMOC COC

		<div style="border: 1px solid black; padding: 2px; display: inline-block;">ERG Lab ID # _____</div>
AIR TOXICS SAMPLE CHAIN OF CUSTODY		
Lab Pre-Sampling	Site Code: _____	Canister Number: _____
	City/State: _____	Lab Initial Can. Press. ("Hg): _____
	AQS Code: _____	Cleaning Batch #: _____
	Collection Date: _____	Date Can. Cleaned: _____
	Options:	
	SNMOC (Y/N): _____ TOXICS (Y/N): _____ METHANE (Y/N): _____ Relinquished by: _____ Date: _____	Duplicate Event (Y/N): _____ Duplicate Can #: _____
Field Setup	Received by: _____	Date: _____
	Operator: _____	MFC Setting: _____
	System #: _____	Elapsed Timer Reset (Y/N): _____
	Setup Date: _____	Canister Valve Opened (Y/N): _____
	Field Initial Can. Press.: _____ psig psia "Hg (Circle one)	
Field Recovery	Recovery Date: _____	Sample Duration (3 or 24 hr): _____
	Operator: _____	Elapsed Time: _____
	Field Final Can. Press.: _____ psig psia "Hg (Circle one)	
	Status: VALID VOID (Circle one)	Canister Valve Closed (Y/N): _____
	Relinquished by: _____	Date: _____
Lab Recovery	Received by: _____	Date: _____
	Lab Final Can. Press.: _____ psig "Hg (Circle one)	Converted to psia: _____
	Status: VALID VOID (Circle one)	Gauge: 1 2 (Circle one)
	If void, why: _____	
<i>Samples stored in Air Tox Lab (Room 130)</i>		

Comments: _____

White: Sample Traveler

Canary: Lab Copy

Pink: Field Copy

Figure 9-2. Example Air Toxics COC

Upon receipt, the sample canister vacuum/pressure is measured and compared against the field documented vacuum/pressure to ensure the canister remained airtight during transport. If the receiving vacuum differs from the field vacuum more than 3“Hg, the program manager is notified, and sample canister may be voided. Because there are potential differences in barometric pressures and temperatures between the sampling site and the receiving laboratory (such as those sites at high altitudes), and different accuracies for different types of pressure gauges, there can be a consistent difference in final field pressure and lab receipt pressure for canister samples. This difference and other parameters are considered to determine the validity of the canister samples. These are monitored daily and the pressures are logged into an Excel spreadsheet. This allows the laboratory the ability to determine if the difference is due to gauges or if the canister leaked en route. A sample of the spreadsheet is presented in Table 9-1.

Table 9-1
Example of Canister Pressure Check Spreadsheet

Date Received	Site	Field Pressure Reading	Lab Pressure Reading	Difference
8/30/16	NBIL	2 “Hg	6 “Hg	4 “Hg
9/7/16	NBIL	1 “Hg	4 “Hg	3 “Hg
9/14/16	NBIL	3 “Hg	7 “Hg	4“Hg
9/16/16	NBIL	4 “Hg	7 “Hg	3 “Hg
8/30/16	BLKY	5 “Hg	5 “Hg	0 “Hg
9/7/16	BLKY	5 “Hg	3.5 “Hg	1.5 “Hg
9/13/16	BLKY	5 “Hg	5 “Hg	0 “Hg
9/16/16	BLKY	5 “Hg	4 “Hg	1 “Hg

The canister should be cleaned no more than 30 days before sampling. If the canister is older than 30 days, a note will be made in LIMS and a flag will be added to the sample results in AQS. More detailed sample receipt procedures and sample acceptance policies are presented in the *SOP for Sample Receipt at the ERG Chemistry Laboratory*, ERG-MOR-045 in Appendix C. The sample specific information from the COC is then entered into LIMS (example login page is shown in Figure 9-3) following the *SOP for Sample Login to the Laboratory Information Management System*, ERG-MOR-079 found in Appendix C. The sample is given a unique LIMS

identification (ID) number and tagged (see Figure 9-4), noting the site location and the sample collection date.

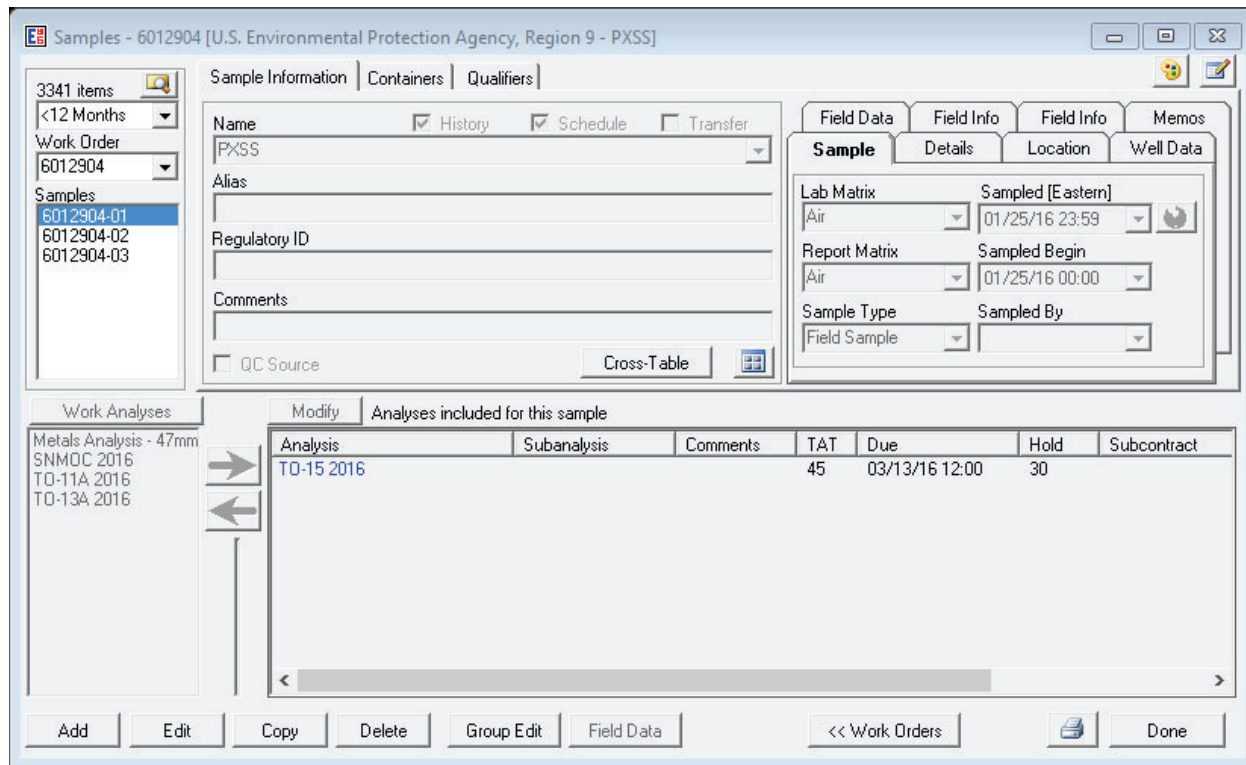

Figure 9-3. Example ERG LIMS Login Page

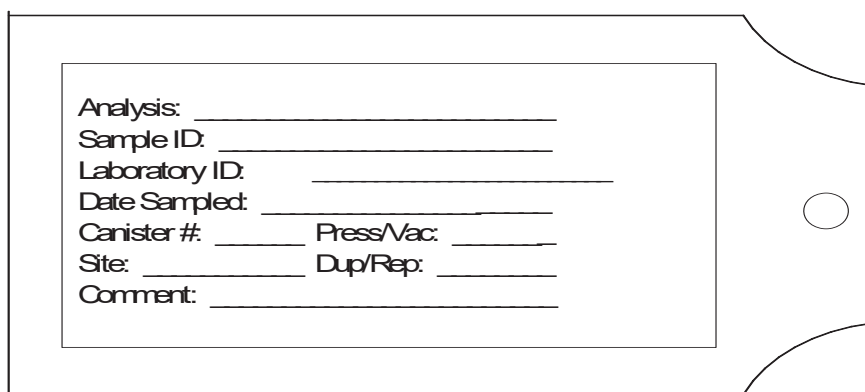

Figure 9-4. Canister Tag

The LIMS ID number is recorded on the canister tag and on all ERG copies of the COC. The remaining copies of the canister sample COC are separated. The white copy is scanned (the

PDF is stored in the LIMS system) and is kept with the canister sample until analysis is complete. After sample analysis, the white copy goes into the data package with the sample data. The yellow copy is stored chronologically in a designated file cabinet for one year. The file cabinet is in Room 102 in the Laboratory building.

9.1.2 Canister Analytical Routing Schedule

Each canister has a unique canister identification number inscribed on the canister. This number is used during can cleaning, field collection, laboratory receipt, and laboratory sample analysis and is included on the individual Toxics/SNMOC COCs and entered into the LIMS.

The canister sample analysis hold time is 30 days from the sampling date. The samples are sent to the ERG Air Toxics Laboratory for VOC and SNMOC/PAMS GC/Flame Ionization Detector/Mass Spectrometer (FID/MS) analysis. The canister sample is analyzed and kept in the laboratory until after the analyst reviews the relevant analytical data.

9.1.3 Canister Cleanup

All canisters are cleaned prior to reuse following SOP ERG-MOR-105 (*SOP for Sample Canister Cleaning using Wasson TO-Clean Automated System*) as shown in Appendix C. The canisters are cleaned using the procedure described in Section 10.1.1. The unheated system (following SOP ERG-MOR-062, *SOP for Sample Canister Cleaning*) is maintained as a backup, if needed, and is described in Section 10.1.2. The canisters are cleaned to <3x MDL or 0.2 parts per billion by volume (ppbV), whichever is lower, and 20 parts per billion as Carbon (ppbC) for Total SNMOC. If the canister fails the Blank criteria, it is returned to the cleaning system bank with the other canisters that were cleaned along with it and all canisters are put through an additional Vacuum and Pressure cycle. The same canister is analyzed again. All canisters, whether used for NMOC, SNMOC, UATMP, NATTS, CSATAM, or PAMS, are cleaned by the same procedure and are entered into the canister cleanup log, shown in Figure 9-5 for the heated systems and in Figure 9-6 for the unheated systems.

Heated Canister Cleaning Systems Logbook
 2016-2

Heated System 1

Upper			
Rear			
Front			
Lower			
Rear			
Front			

Batch ID _____

Cleaning Date _____

Initials _____

Program _____

Oven Temperature (°C) _____

Leak Check _____

	Pass
	Fail

Extra Cycle Date _____

Final Evac Date _____

Heated System 2

Upper			
Rear			
Front			
Lower			
Rear			
Front			

Batch ID _____

Cleaning Date _____

Initials _____

Program _____

Oven Temperature (°C) _____

Leak Check _____

Review Initials & Date _____

Extra Cycle Date _____

Final Evac Date _____

L:\Forms\Canister cleaning\Wasson Can Cleaning system log.v2.xlsx

Figure 9-5. Canister Cleanup Log for the ERG Heated Cleaning System

Canister Cleaning Logbook 2016-1

Batch ID	Date										
Upper											
P1	P5	Req. Cycle 1 V (Time)	P (Time)	Req. Cycle 2 V (Time)	P (Time)	Req. Cycle 3 V (Time)	P (Time)	Req. Cycle 4 V (Time)	Pass or Fail		
P2	P6										
P3	P7										
P4	P8										
Leak Check		Start (psi)		Upper		Lower					
		End (psi)									
		Difference*									
* Must be <0.5 psi											
Batch ID		Date									
Lower											
P1	P5	Req. Cycle 1 V (Time)	P (Time)	Req. Cycle 2 V (Time)	P (Time)	Req. Cycle 3 V (Time)	P (Time)	Req. Cycle 4 V (Time)	Pass or Fail		
P2	P6										
P3	P7										
P4	P8										
Final Evac.		Date		Time							
Reviewer Initials/Date: _____ Canister IDs _____ Times/Intervals _____											

L:\Forms\Canister cleaning\Canister Cleaning Logbook 2016-1.xlsb

Figure 9-6. Canister Cleanup Log for the ERG Unheated Cleanup System

9.2 Carbonyl Sample Custody

Figure 9-7 shows the color-coded, three-copy COC form used for all carbonyl sampling documentation. A COC is shipped to the site with the carbonyl cartridges. After sampling, the COC form is completed by the site operator and the pink copy is retained for site records. The carbonyl sample cartridges and remaining COC copies are shipped to ERG's analytical laboratory.

When samples are received, they are logged into the LIMS database and given a unique LIMS ID number following the *SOP for Sample Login to the Laboratory Information Management System*, SOP ERG-MOR-079, found in Appendix C. The remaining copies of the COC are separated. The white copy of the COC is scanned (the PDF is stored in the LIMS system) and is labeled with the LIMS ID number, site code, sampling date, individual sample designations, and date of receipt and initials of receiving personnel and put into a bag. The sample bag is stored in a refrigerator designated for carbonyl samples only. The yellow copy is stored chronologically in a designated file cabinet for one year. The file cabinet is in Room 102 in the Laboratory building. More detailed sample receipt procedures and sample acceptance policies are presented in the *SOP for Sample Receipt at the ERG Chemistry Laboratory*, ERG-MOR-045.

9.2.1 Carbonyl Analytical Routing Schedule

The carbonyl cartridge samples are extracted within 14 days of the sampling day and analyzed within 30 days after extraction. The extracts are kept in the designated extract refrigerator until after the analyst and the Task Leader reviews all the relevant analytical data.



ERG Lab ID # _____

601 Kaystone Park Drive, Suite 700, Morrisville, NC 27560

CARBONYL COMPOUNDS CHAIN OF CUSTODY

Lab Pre-Samp.	Site Code: _____ City/State: _____ AQS Code: _____ Relinquished by: _____ Date: _____	Collection Date: _____ Cartridge Lot #: _____ Duplicate Event (Y/N): _____
Field Setup	Received by: _____ Date: _____ Set-Up Date: _____ Operator: _____ Sys. #: _____ Pre-Sampling Rotameter Reading (cc/min): _____ Elapsed Timer Reset (Y/N): _____	
Field Recovery	Recovery Date: _____ Sample Duration (3 or 24 hr): _____ Operator: _____ Elapsed Time: _____ Post Sampling Rotameter Reading (cc/min): _____ Status: VALID VOID (Circle one) Cartridges Capped (Y/N): _____ Relinquished by: _____ Date: _____	
Lab Recovery	Received by: _____ Date: _____ Status: VALID VOID (Circle one) Uncorrected Temperature: _____ If void, why: _____ Corrected Temperature: _____ Sample Volume (total Liters): _____ IR Gun: 1 2 (Circle one) <p style="text-align: right; margin: 0;"><i>Samples stored in Refrigerator # 11</i></p>	

PAMS	Sample Date	Sample Time	Sample Duration	Sample Volume	Cartridge Lot #	Sample ID	Lab ID

Comments: _____

White: Sample Traveler

Canary: Lab Copy

Pink: Field Copy

Figure 9-7. Example Carbonyl Compounds COC

9.3 HAPs Sample Custody

Samples collected on prepared sample media (i.e., XAD-2[®], Polyurethane Foam (PUF), hexavalent chromium filters, etc.) use supplied three-copy COC forms to document sample collection. Field testing personnel will record applicable collection data (such as time, date, location, meteorological parameters) on the appropriate COC forms (Figures 9-8, 9-9 and 9-10) and keep the pink copies for site records. The COCs are then shipped to ERG with the prepared sample media.

Because the sites supply the filters used for metal analysis, COC forms are normally supplied by the State, Local or Tribal agency for these samples. If needed, however, COC forms can be supplied by ERG electronically inputting multiple filters for metal analysis (Figure 9-11). Samples are received at ERG's laboratory as presented in the *SOP for Sample Receipt at ERG Chemistry Laboratory*, ERG-MOR-045.

All HAPs samples received at the ERG laboratory will be logged into the LIMS as described in the *SOP for Sample Login to the Laboratory Information Management System*, ERG-MOR-079.

9.4 Invalid Samples

The sample COC form may indicate that the sample sent from a site is invalid. The sample can be determined invalid at the site or in the laboratory. SOP ERG-MOR-045 describes the sample receiving procedure and sample acceptance. Individual sites will be contacted if there are any questions about the samples upon receipt. When a sample is designated as invalid, the assigned LIMS ID number is notated as a void and is invalidated on the individual respective COC form. Another sample media will be sent to the site with the COC designated to make up on non-standard sampling days. If the site has repeated invalid samples, normally three voids in a row, the ERG site coordinator Task Leader will work with the site personnel to diagnose and correct the problem. The sites will also be notified in the monthly analytical reports of any invalid samples.



ERG Lab ID # _____

501 Keystone Park Drive, Suite 700, Morrisville, NC 27560

SVOC SAMPLE CHAIN OF CUSTODY

Lab Pre-Sampling	Site Code: _____ City/State: _____ AQS Code: _____ Cartridge Certification Date: _____ Relinquished by: _____ Date: _____	Container #: _____ Collection Date: _____ Collocated Event (Y/N): _____ SUR ID: _____ XAD Lot: _____ PUF Lot: _____ Filter Lot: _____																								
Field Setup	Received by: _____ Date: _____ Site Operator: _____ System #: _____ Set-Up Date: _____ Elapsed Timer Reset (Y/N): _____																									
Field Recovery	Recovery Date: _____ <div style="text-align: center; font-weight: bold; font-size: small;">Collection System Information:</div> <table border="1" style="width: 100%; border-collapse: collapse; font-size: x-small;"> <thead> <tr> <th></th> <th>Elapsed Time</th> <th>Temp (°C)</th> <th>Barometric ("Hg)</th> <th>Magnehelic ("H₂O)</th> <th>Flowrate (std. m³/min)</th> </tr> </thead> <tbody> <tr> <td>Start</td> <td>_____</td> <td>_____</td> <td>_____</td> <td>_____</td> <td>_____</td> </tr> <tr> <td>End</td> <td>_____</td> <td>_____</td> <td>_____</td> <td>_____</td> <td>_____</td> </tr> <tr> <td>Average</td> <td>_____</td> <td>_____</td> <td>_____</td> <td>_____</td> <td>_____</td> </tr> </tbody> </table> Total Collection Time (Minutes) _____ Total Collection Volume (std. m ³) _____ Status: Valid Void (Circle one) Site Operator: _____ Relinquished by: _____ Date: _____			Elapsed Time	Temp (°C)	Barometric ("Hg)	Magnehelic ("H ₂ O)	Flowrate (std. m ³ /min)	Start	_____	_____	_____	_____	_____	End	_____	_____	_____	_____	_____	Average	_____	_____	_____	_____	_____
	Elapsed Time	Temp (°C)	Barometric ("Hg)	Magnehelic ("H ₂ O)	Flowrate (std. m ³ /min)																					
Start	_____	_____	_____	_____	_____																					
End	_____	_____	_____	_____	_____																					
Average	_____	_____	_____	_____	_____																					
Lab Recovery	Received by: _____ Date: _____ Container #: _____ Status: Valid Void (Circle one) Uncorrected Temperature: _____ If void, why: _____ Corrected Temperature: _____ <div style="text-align: right; font-size: small;">Thermometer: IR1 IR2 (Circle one)</div> <div style="text-align: right; font-weight: bold; font-size: small;">Samples stored in Refrigerator # 7</div>																									

07-2017

Comments: _____

White: Sample Traveler

Canary: Lab Copy

Pink: Field Copy

Figure 9-8. Example SVOC Sample COC

		ERG Lab ID # _____
601 Keystone Park Drive, Suite 700, Morrisville, NC 27560 AMBIENT HEXAVALENT CHROMIUM CHAIN OF CUSTODY FORM		
Lab Pre-Sampling	Site Code: _____ Collection Date: _____ City/State: _____ Primary Event (Y/N): _____ AQS Code: _____ Collocated Event (Y/N): _____ Relinquished by: _____ Date: _____	
Field Setup	Received by: _____ Date: _____ Site Operator: _____ System #: _____ Set-Up Date: _____ Elapsed Timer Reset (Y/N): _____ Collection Date: _____ Batch I.D. No.: _____ Initial Rotameter Setting (C.O.B.): _____ (After 5 minutes warm-up) Programmed Start Time: _____ Programmed End Time: _____	
Field Recovery	Recovery Date: _____ Recovery Time: _____ Site Operator: _____ Final Rotameter Reading (C.O.B.): _____ (After 5 minutes warm-up) Elapsed Time: _____ Status: Valid Void (Circle one) Relinquished by: _____ Date: _____	
Lab Recovery	Received by: _____ Date: _____ Container #: _____ Status: Valid Void (Circle one) Uncorrected Temperature: _____ If void, why: _____ Corrected Temperature: _____ Collection Time (Minutes): _____ IR Gun: 1 2 Avg. Flowrate (L/min): _____ (Circle one) Total Volume of Air Sampled (m ³): _____ <div style="text-align: right; font-weight: bold; font-size: small;"> Samples stored in Freezer # 11 </div>	
Comments: _____ _____ _____		

White: Sample Traveler

Canary: Lab Copy

Pink: Field Copy

Figure 9-9. Example Ambient Hexavalent Chromium COC



ERG Lab ID # _____

501 Keystone Park Drive, Suite 700, Morrisville, NC 27560

PM₁₀ / TSP METALS CHAIN OF CUSTODY

Lab Pre-Samp.	Site Code: _____ Collection Date: _____ City/State: _____ Duplicate Event (Y/N): _____ AQS Code: _____ Relinquished by: _____ Date: _____
Field Setup	Received by: _____ Date: _____ Set-Up Date: _____ Operator: _____
Field Recovery	Recovery Date: _____ Sample Duration (i.e. 24 hr): _____ Status: Valid Void (Circle one) Relinquished by: _____ Date: _____
Lab Recovery	Received by: _____ Date: _____ Status: Valid Void (Circle one) If void, why: _____

Samples stored in ICP-MS Lab (Room # 128)

PM ₁₀ / TSP METALS	Sample Date	Start Time	End Time	Total Time	System #	Total Vol (m ³)	Lab ID	

Comments: _____

White: Sample Traveler

Canary: Lab Copy

Pink: Field Copy

Figure 9-10. Example Metals COC

9.5 Analytical Data

After analysis, the laboratory will provide narratives describing any anomalies and modifications to analytical procedures, data and sample handling records, and laboratory notes for inclusion in the final report. All laboratory electronic records will be stored for archive on Digital Versatile Disk (DVD), or shared network drive. DVDs are stored in Room 102 in the Laboratory building and the shared network has limited access. Raw data will be stored on the shared network for at least 5 years after the end of the closed contract.

All records generated by measurement activities are signed or initialed by the person performing the work and reviewed by an appropriate Task Leader. Measurement results become part of a project report, of which 10 percent is requested by the QA Coordinator (or a reviewer designated by the QA Coordinator) for review.

9.6 Sampling Monitoring Data

All COC forms from the monitoring sites will be stored with the analytical results. The forms are also scanned and stored in the LIMS as described in the *SOP for Sample Login to the Laboratory Information Management System*, SOP ERG-MOR-079. The COC forms will be reviewed by the sample custodian(s), Task Leaders and Program Manager. The laboratory will contact the individual site if necessary information is not completed on the COC forms. The original field data will remain in ERG custody and will eventually be stored on file with the final report until 5 years after the end of the closed contract.

SECTION 10

ANALYTICAL METHODS REQUIREMENTS

Analytical procedures are program-specific because the instrumentation and the target compounds of the four programs differ. The primary analytical instrument is GC/FID/MS for SNMOC, VOCs and PAMS hydrocarbons; High Performance Liquid Chromatography (HPLC) for carbonyls; GC/MS for Semivolatiles (SVOC); Inductively Coupled Plasma/Mass Spectrometer (ICP-MS) for Metals; and Ion Chromatography (IC) for Hexavalent Chromium. All samples taken for SNMOC, VOCs, or PAMS hydrocarbons can be evaluated by GC/FID/MS because the instrumentation is collecting all of the data at the same time. Corrective action for analytical system failures realized at time of analyses is initiated by the Analyst and supported by the Task Leader for that method. All analytical method SOPs are provided in Appendix C. The methods used for NMOC and other individual HAPs analysis not currently discussed will be added to this QAPP when the individual States request the analyses. Samples will not be analyzed until ERG receives approval from EPA.

The SOPs for each method are reviewed annually and updated as necessary. The QA Coordinator, Program Manager and Writer/Editor will review, sign and date SOPs before distributing to the laboratories satellite file areas. The previous copies will be replaced with the revised edition. The original, and all previously revised edits, are stored in a historical file maintained by ERG's Project Administrator.

10.1 Canister Cleanup System

The canisters are cleaned using a Wasson TO-Clean Model TO 0108 heated canister cleaning system and is explained in Section 10.1.1. The unheated system is used as backup and is described in Section 10.1.2. A bulk liquid N₂ dewar is located external to the ERG laboratory facility. This dewar continuously produces a volume of ultrapure gaseous N₂ in its headspace area (~100 psig) that is more than adequate to accommodate all in-lab gaseous N₂ applications. Ultrapure gaseous N₂ is extracted from the dewar headspace and delivered to the cleaning

systems. Transport of the gas is accomplished through a 3/8" outer diameter (OD) pre-cleaned stainless-steel tubing.

10.1.1 Heated Canister Cleaning System

The TO-Clean heated cleaning systems are commercially available systems manufactured by Wasson-ECE (Figure 10-1). These systems can clean up to twelve canisters per system at a selected temperature from ambient to 100°C. Each system consists of an oven that holds the canisters, an Edwards RV8 vacuum pump, a stainless-steel humidification chamber for the dilution gas, and a control unit. The procedure for cleaning canisters is the *SOP for Sample Canister Cleaning using the Wasson-ECE*, ERG-MOR-105 in Appendix C.

The cleaning system oven has enough capacity to clean up to 12 canisters at a time. Two racks hold up to six canisters each. Canisters are connected to a 12-port, two-level manifold with compression fittings and flexible stainless-steel tubing. Ultra-pure N₂ is the dilution gas and is applied to the manifold via an electrically actuated valve. Vacuum is applied to the manifold through a pneumatically-actuated vacuum valve. The oven is heated to 40°C during the cleaning cycles.

The control unit controls the pressure, vacuum, and vent valves and houses the front panel control unit and oven temperature controller. The touchscreen front panel control stores and executes the cleaning programs, provides manual valve control and leak check diagnostics, and displays vacuum, pressure, and program time information. The oven temperature controller is separate from the front panel control within the control unit and regulates the oven temperature to a preset value.

The Edwards RV8 vacuum pump is separated from the system by a cryogenic trap. This trap removes contaminants and water vapor from the canisters before reaching the pump, and it prevents the sample canisters from being contaminated by back-diffusion of hydrocarbons from the vacuum pump into the cleanup system. The humidifier system is a modified SUMMA[®]-treated 6-liter canister partially filled with HPLC-grade water. The ultra-pure N₂ dilution gas is

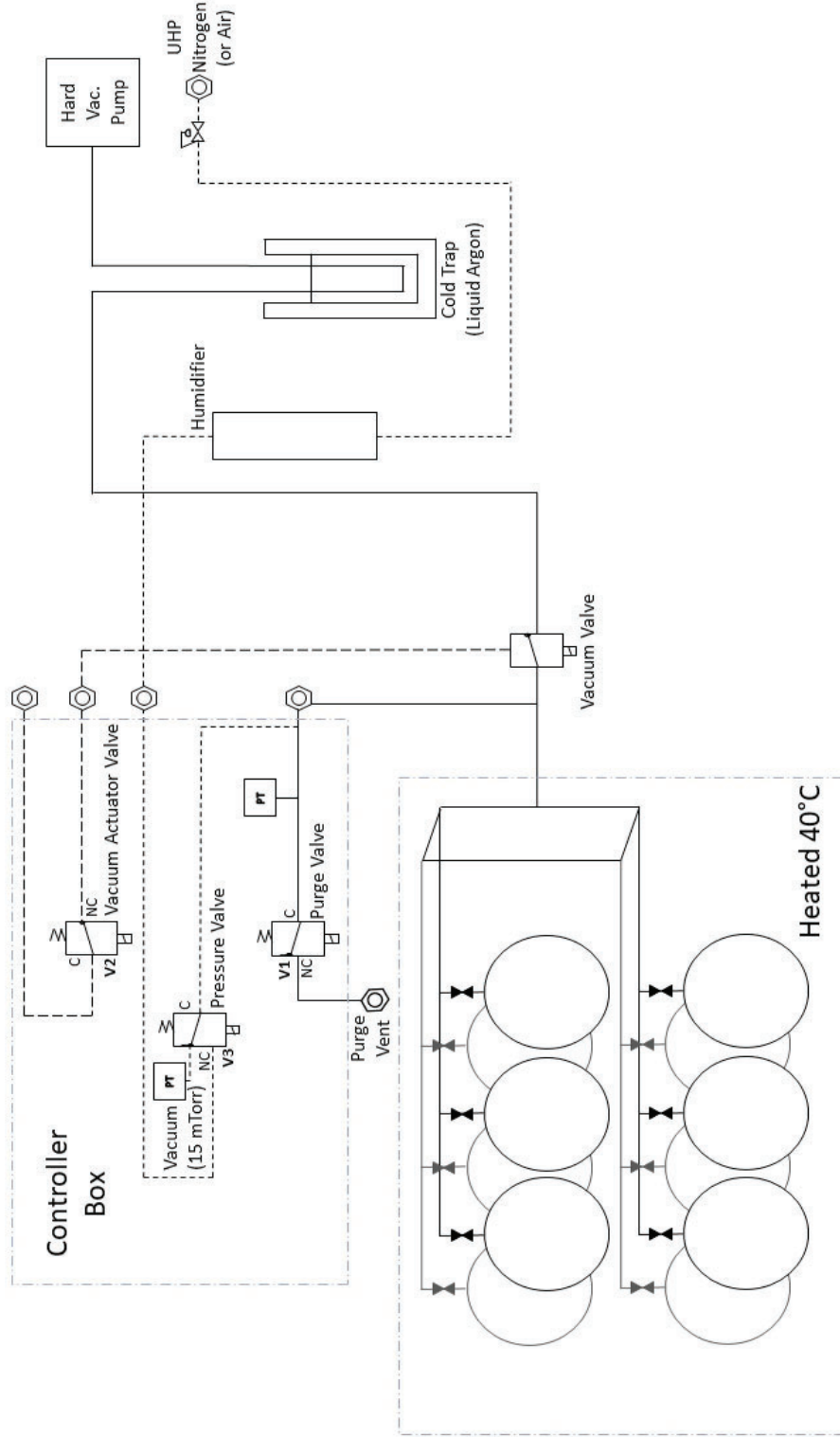

Figure 10-1. Heated Canister Cleanup System Schematic

bubbled through the water prior to entering the manifold, achieving an estimated relative humidity of 75 percent.

After sample analyses and data review are completed, 12 canisters are connected to the manifold in the oven. The bellows valve on each canister is opened. The vacuum pump is started and one of the vacuum routing valves is opened, drawing a vacuum on the canisters connected to the corresponding manifold. The canisters are evacuated to a vacuum reading of 400 millitorr and held for 45 minutes. The vacuum valve is then closed and the ultrapure gaseous N₂ that has been humidified is introduced into the evacuated canisters at a rate of 5.0 liters per minute until the pressure in the canisters reach approximately 20 psig. This evacuation and pressurization of the canisters constitutes one Cleanup Cycle.

The Cleanup Cycle is repeated twice more to facilitate a complete canister cleanup procedure. Following the third pressurization, the canister bellows valves are closed and one canister (out of the 12 cleaned) is selected for cleanliness verification analysis. The cleanliness of the canister is qualified by GC/MS and FID analysis. The pass/fail results of the analyses are documented on a shared network so that the pass/fail rate can be monitored. The cleanliness criterion for each bank of 12 canisters is < 3x MDL or 0.2 ppbV for each individual VOC, whichever is lower, and 20 ppbC for Total SNMOC. If the canister does not pass the cleanliness criteria, the canister is reconnected to the cleanup manifold with the other 11 canisters it was cleaned with and another cleaning cycle is performed, and the same canister is analyzed again. Upon meeting these criteria, the canister is reconnected to the cleanup manifold with the other 11 canisters constituting the original bank of 12. All 12 canister bellows valves are opened, and the canisters are evacuated to a vacuum reading of 50 millitorr. The bellow valves are closed, and canisters are ready to be packaged and shipped to each network site.

10.1.2 Unheated Canister Cleaning System

A canister cleanup system (Figure 10-2) has been developed and is used to prepare sample canisters for use in collecting representative whole air samples (*SOP for Sample Canister*

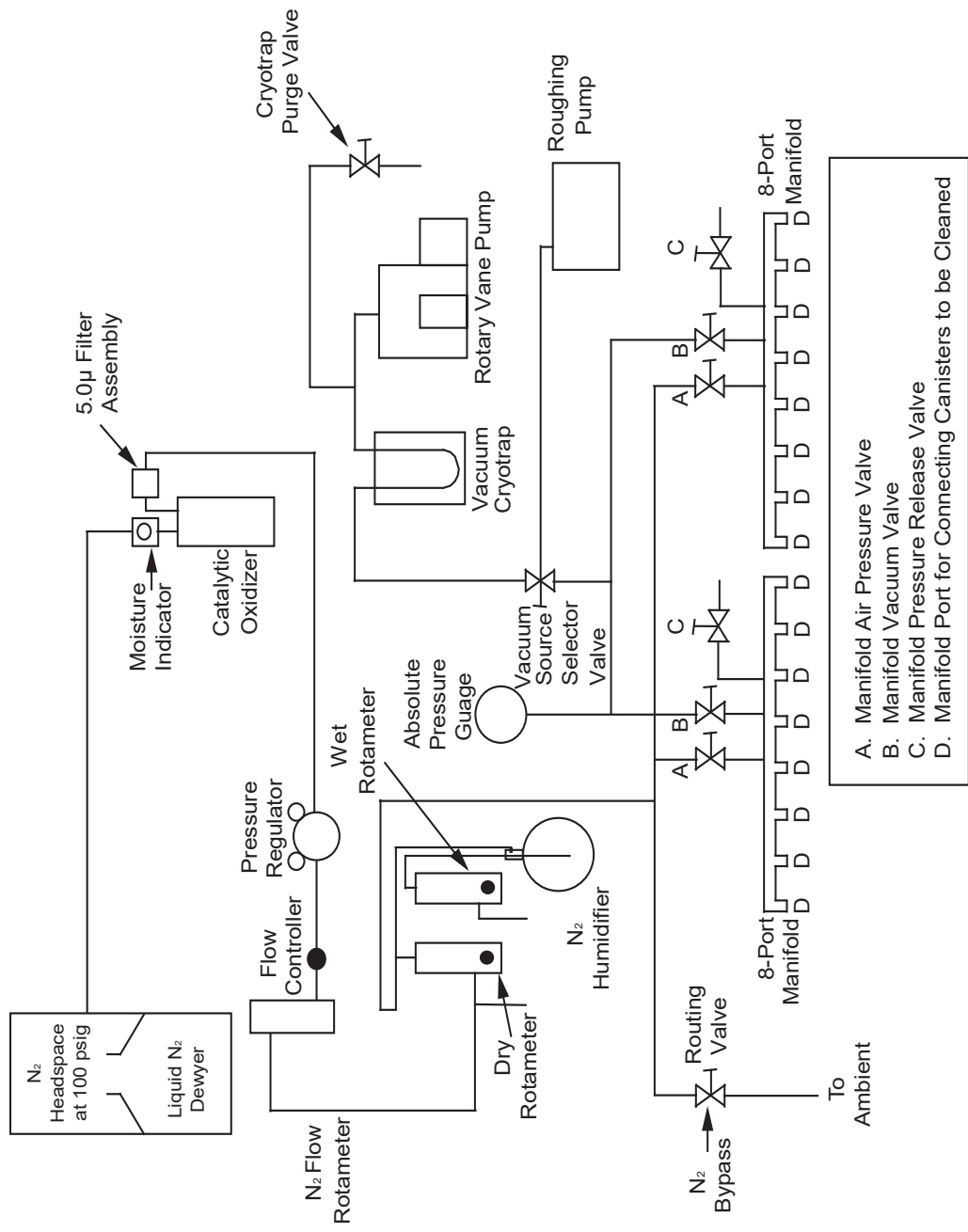

Figure 10-2. Unheated Canister Cleanup System Schematic

Cleaning, ERG-MOR-062 in Appendix C). This cleaning system is used as a backup to the heated canister cleaning system explained in Section 10.1.1.

A single-stage regulator controls the final N₂ pressure in the canisters and a metering valve is used to control the flow rate at which the canisters are filled during a cleanup cycle. The flow direction is controlled by a separate flow meter, installed in the N₂ gas line. A shutoff valve exists between the N₂ gas line and the humidifier system (which is a modified SUMMA[®]-treated 6-liter canister partially filled with HPLC-grade water). One rotameter and flow-control valve direct the gaseous N₂ into the humidifier where it is bubbled through the HPLC-grade water. A second flow-control valve and flow meter allow gaseous N₂ to bypass the humidifier system, if desired. By setting the flow-control valves separately, the downstream relative humidity can be regulated. Approximately 75 percent relative humidity is used for canister cleaning. This is accomplished by routing 100 percent of the gaseous N₂ flow through the humidifier. Another shutoff valve is located between the humidifier and each 8-port manifold where the canisters are connected for cleanup.

The vacuum system consists of a Precision Model DD-310 vacuum pump, a cryogenic trap, a vacuum and pressure gauge, and a manifold vacuum valve connected as shown in Figure 10-1. The cryogenic trap prevents the sample canisters from being contaminated by back-diffusion of hydrocarbons from the vacuum pump into the cleanup system. The manifold vacuum valves enable isolation of the vacuum pump from the system without shutting off the vacuum pump.

After sample analyses and data review are completed, a bank of eight canisters is connected to each manifold as shown in Figure 10-1. The canister bellows valve on each canister is opened. The vacuum pump is started and one of the vacuum routing valves is opened, drawing a vacuum on the canisters connected to the corresponding manifold. The bank of eight canisters is evacuated to a vacuum reading of 29.5“ Hg (as indicated by the pressure gauge), and held for 30 minutes. The vacuum routing valves are then closed and the ultrapure gaseous N₂ that has been humidified is introduced into the evacuated canisters at a rate of 4.0 liters per minute until

the pressure in the canisters reach approximately 20 psig. This “Evacuation and Pressurization” of the canisters constitutes one Cleanup Cycle.

The Cleanup Cycle is repeated twice more to facilitate a complete canister cleanup procedure. Following the third pressurization, the canister bellows valves are closed and one canister (out of the eight cleaned) is selected for cleanliness verification analysis. The cleanliness of the canister is qualified by GC/MS and FID analysis. The pass/fail results of the analyses are documented on a shared network so that the pass/fail rate can be monitored. The cleanliness criterion for each bank of eight canisters is < 3x MDL or 0.2 ppbV for each individual VOC, whichever is lower, and 20 ppbC for Total SNMOC. If the canister does not pass the cleanliness criteria, the canister is reconnected to the cleanup manifold with the other seven canisters it was cleaned with and another cleaning cycle is performed, and the same canister is analyzed again. Upon meeting these criteria, the canister is reconnected to the cleanup manifold with the other seven canisters constituting the original bank of eight. All eight canister bellows valves are opened and the canisters are evacuated to a vacuum reading of approximately 29.5“ Hg for a fourth time. The bellow valves are closed, and the canisters are ready to be packaged and shipped to each network site.

10.2 VOC and Concurrent Analytical System

The VOC GC/FID/MS analyses are performed on a 250-milliliter (mL) sample from the canister with an Agilent 6890 GC/FID and an Agilent 5975 MS with Selected Ion Monitoring (SIM) using a 60 m by 0.32-millimeter (mm) Inner Diameter and a 1-micrometer (µm) film thickness Restek R_{xi}-1_{ms} capillary column followed by a Y-union connector that splits the mobile phase between the MS and the FID. Table 10-1 shows the GC/FID/MS operating conditions. Figure 10-3 shows the GC/FID/MS system arrangement. Canister samples must be analyzed within 30 days from sample collection. The analytical *SOP for the Concurrent GC/FID/MS Analysis of Canister Air Toxic Samples using EPA Compendium Method TO-15 and EPA Ozone Precursor Method* (ERG-MOR-005) is presented in Appendix C.

Table 10-1
VOC GC/FID/MS Operating Conditions

Parameter	Operating Value
Sample Volume	250 mL
Restek R _{xi} -1 _{ms} Capillary Column: Length: Inside diameter: Film thickness: Oven temperature:	60 m 0.32 mm 1 µm -50°C for 5 minutes, 15°C/min to 0°C then 5°C/min to 150°C, then 25°C/min to 220°C for 1 minute then 25°C/min to 150°C for 4 minutes
Temperatures: FID: Injector Oven Temperature: MS Quad Temperature: MS Source Temperature:	300°C 220°C 200°C 280°C (350°C 5975)
Gas Flow Rates: Column Carrier Gas (Helium (He)): FID Make-up (He): FID (Hydrogen (H ₂)): FID (Air):	2 mL/min 30 mL/min 30 mL/min 300 mL/min
Entech Sample Interface Conditions: Module 1 - Glass Bead/Tenax® Trap Initial Temperature: Module 2 - Tenax® Trap Initial Temperature: Module 3 - Cryofocuser Temperature:	-150°C -50°C -196°C

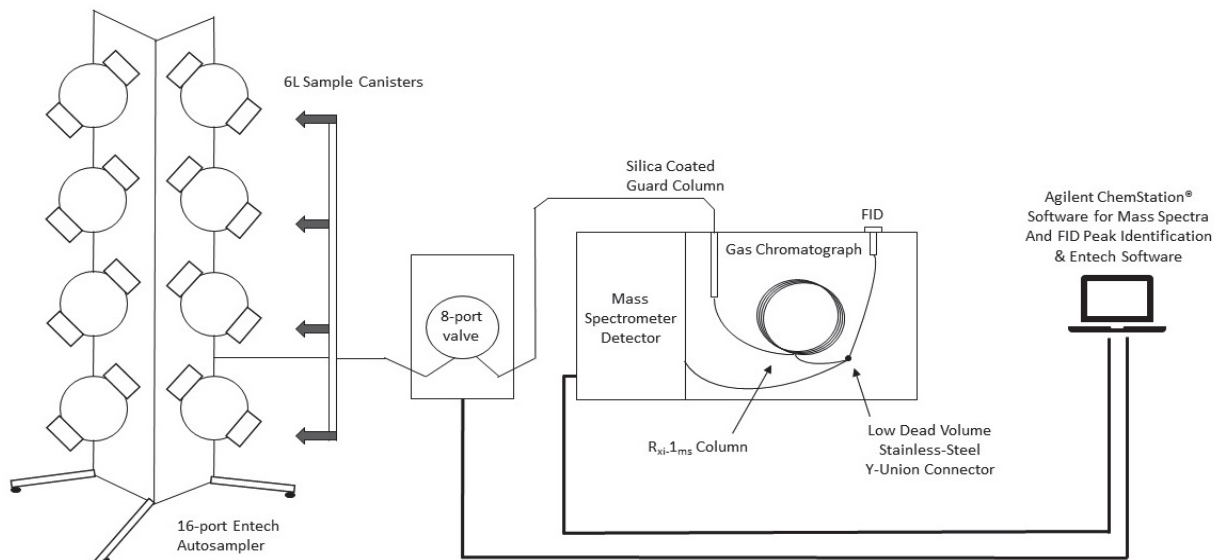

Figure 10-3. VOC GC/MS/FID System

10.3 Carbonyl Analytical System

Carbonyl samples are stored in the refrigerator after they are received from the field prior to analysis. The carbonyl cartridge samples are extracted within 14 days of the sampling day and analyzed within 30 days after extractions. Sample preparation is performed by removing the DNPH sampling cartridge from its shipping container and attaching it to the end of a 5 mL Micro-Mate[®] glass syringe. Five mL of acetonitrile are added to the syringe and allowed to drain through the cartridge into a 5 mL Class A volumetric flask and diluted to the 5 mL mark with acetonitrile. This solution is then transferred to a 2 mL autosampler vial fitted with a Teflon-lined, self-sealing septum and a 4 mL vial with a Teflon-lined cap and both vials are stored in a refrigerator at 4°C until analysis.

The analytical separation of carbonyls is performed using a Waters HPLC configured with a reverse-phase 250 mm by 4.6 mm C-18 silica analytical column with a 5-micron particle size. A typical HPLC system is shown in Figure 10-4. ERG's system uses an Agilent HPLC chromatographic data software system. Typically, 15-microliters (µL) samples are injected with an automatic sample injector. A mobile phase gradient of water, acetonitrile, and methanol is

used to perform the analytical separation at a flow rate of 1.0 mL/minute. A multiwavelength Ultraviolet (UV) detector is operated at 360 nanometer (nm). The complete *SOP for Preparing, Extracting, and Analyzing DNPH Carbonyl Cartridges by Method TO-11A* (ERG-MOR-024) is presented in Appendix C. Sample and waste disposal procedures are outlined in ERG-MOR-033, the *SOP for Hazardous Waste*.

10.4 Polycyclic Aromatic Hydrocarbons Analytical Systems

Sampling modules containing PUF/XAD-2[®], petri dishes containing glass microfiber filters, and COC forms and all associated documentation will be shipped to the ERG laboratory from the field. Each filter should be folded in quarters, placed inside the cartridge (with the XAD/PUF) and capped before shipment. Upon receipt at the laboratory, samples will be logged into the LIMS system and stored in the refrigerator. Sample preparation and analysis procedures are based on EPA Compendium Method TO-13A⁽¹⁰⁾ and ASTM D6209-13⁽¹²⁾ method. The hold time is 14 days after sampling for extraction and 40 days after extraction for analysis.

Sample extracts will be analyzed for PAHs using GC/MS in SIM. The MS will be tuned and mass-calibrated as required using perfluorotributylamine (FC-43), per the analytical procedures presented in the *SOP for analysis of Semivolatile Organic Compounds (Polynuclear Aromatic Hydrocarbons) Using EPA Compendium Method TO-13A and ASTM D6209* (ERG-MOR-049) (see Appendix C). Sample and waste disposal procedures are outlined in ERG-MOR-033, the *SOP for Hazardous Waste*.

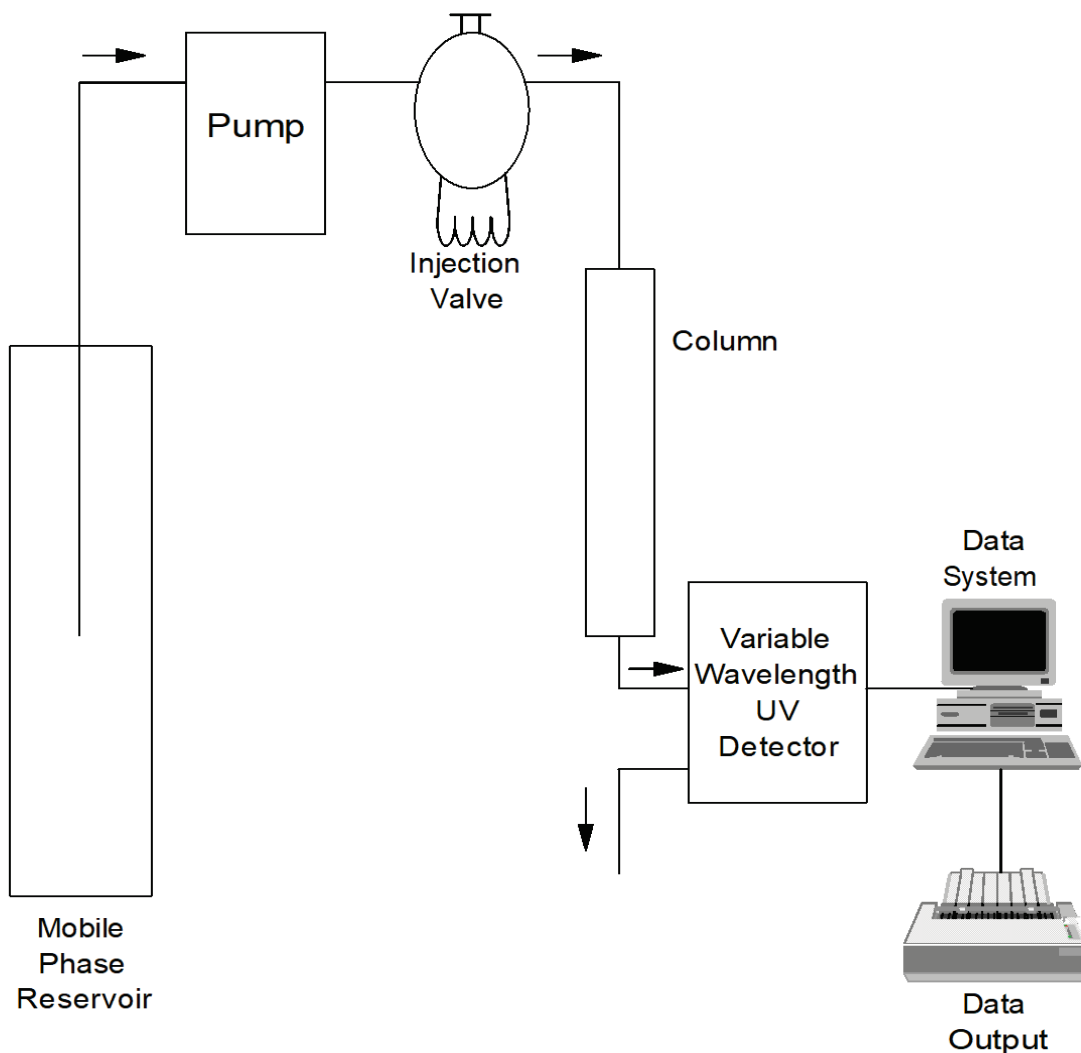

Figure 10-4. HPLC System

10.5 Metals Using an Inductively Coupled Argon Plasma Mass Spectrometry Analytical System

Upon receipt from the field, the samples are checked against the COC forms and then logged into the LIMS system. Each sample component is examined to determine if damage occurred during travel. Color, appearance, and other sample particulars are noted. Sample preparation and analysis procedures are based on EPA Compendium Methods IO-3.1⁽²²⁾ and IO-3.5⁽⁶⁾, respectively for the Determination of Metals in Ambient Particulate Matter using ICP-MS techniques. A complete description of the preparation and analytical procedures are

presented in the SOPs for quartz and glass fiber (8x10") filter prep (ERG-MOR-084) and for Teflon 47mm filter prep (ERG-MOR-085) and analysis (ERG_MOR-095) in Appendix C. These procedures were approved as NAAQS Federal Equivalency Methods (FEM) for the analysis of Lead for Total Suspended Particulate (TSP) on quartz and glass fiber filters (EQL-0512-201⁽⁷⁾) and for PM₁₀ on Teflon filters (EQL-0512-202⁽⁸⁾). Analysis hold time for metals filters is 180 days.

The ICP-MS consists of an inductively coupled plasma source, ion optics, a quadrupole MS, a recirculator and an autosampler. The MS will be mass calibrated and resolution checked. Resolution at low mass is indicated by magnesium isotopes ⁷Li, ²⁴, ²⁵, and ²⁶Mg, ⁵⁹Co, ¹¹⁵In, ²⁰⁶, ²⁰⁷, and ²⁰⁸Pb and U²³⁸. Instrument stability must be demonstrated by running a tuning (daily performance check) solution [1 micrograms per liter (µg/L) of barium, bismuth, cerium, cobalt, indium, lead, lithium and uranium, and 15 µg/L of magnesium] 10 times with a resulting Relative Standard Deviation (RSD) of absolute signals for all analytes less than 2 or 5 percent, depending on element and instrument acquisition mode. Sample and waste disposal procedures are outlined in ERG-MOR- 033, the *SOP for Hazardous Waste*.

10.6 Hexavalent Chromium Analytical System

Hexavalent chromium filter samples are stored in the freezer after they are received from the field prior to analysis. Internal studies have shown that the hexavalent chromium does not degrade for up to 21 days if the samples are stored in the freezer before extraction. Upon receipt from the field, the samples are checked against the COC forms and then logged into LIMS. Due to oxidation/reduction and conversion between the trivalent and hexavalent chromium, the extraction is performed immediately prior to analysis. Therefore, it is important that the IC be equilibrated, calibrated and ready for analysis before filters are extracted. Sample preparation is performed by removing the filter from the filter holder and placing it into a 14 mL polystyrene tube. The filters are extracted in 10 mL of a 20 millimolar (mM) sodium bicarbonate solution. The tubes are shaken for 45 minutes using a wrist action shaker before a 2.5 mL aliquot is removed for analysis on the IC. All analysis is completed within 24 hours of the filter extraction.

The analytical separation for the hexavalent chromium is performed using a Dionex-600 IC or Dionex ICS-5000 with a Dionex LC 20 Chromatography Enclosure with a post-column reagent delivery device and an advanced gradient pump configured with an IonPac AS7 analytical column and an IonPac NG1 guard column. Both of ERG's ICs use the Dionex Chromeleon® data system. For the Dionex-600 IC, samples are injected using a Dionex AS40 autosampler. The samples analyzed with the Dionex ICS-5000 are injected using an AS-DV autosampler. A mobile phase is used to perform the analytical separation at a flow rate of 1.0 mL/min, and a post-column reagent flow rate of 0.3 mL/min. The multiwavelength UV detector is set at 530 nm. The samples are prepped and analyzed following ASTM D7614-12⁽⁹⁾ method and the *SOP for the Preparation and Analysis of Ambient Air for Hexavalent Chromium by Ion Chromatography* (ERG-MOR-063) that is presented in Appendix C. Sample and waste disposal procedures are outlined in ERG-MOR- 033, the *SOP for Hazardous Waste*.

SECTION 11

QUALITY CONTROL REQUIREMENTS

This section describes the quality control requirements for each of the major program components (NMOC, SNMOC, VOC, Carbonyls, PAMS, HAPs – SVOC, Metals and Hexavalent Chromium). As there is not a current need for some of the HAPS (SVOC analysis following TO-13A⁽¹⁰⁾/SW 846 Method 8270E⁽¹¹⁾, PCB/Pesticides⁽¹³⁾, inorganic acids⁽¹⁴⁾, etc.), this information is not provided. As soon as these analyses are requested by EPA or States, however, the QAPP will be modified and a new set of MDLs will be completed and presented to EPA. The 2018 MDLs are presented in this section.

11.1 Sample Canister Integrity Studies

Before any SNMOC or VOC samples are collected for a program, all stainless-steel sample canisters are checked for leaks. The canisters are evacuated to less than 25” Hg. The canister vacuum, measured on a Heise gauge, and the barometric pressure is recorded. After 7 days, the canister vacuum and barometric pressure is remeasured. The canisters are considered leak-free if there is less than 1” Hg difference in vacuum (adjusted for differences in the barometric pressure). The canisters are then cleaned using the procedure described in Section 10. For the canister to be used without further cleanup, an analysis must show that it meets the quality objective for cleanliness.

11.2 Standard Traceability

The standards used for all analytes are vendor-supplied National Institute of Standards and Technology (NIST) standards or vendor-supplied referenced to a NIST standard. All analytical methods are also certified by comparison to a second source NIST-traceable standard. The ERG-MOR-022 *SOP for the Preparation of Standards in the ERG Laboratory*, provides direction for preparing standards from solid or liquid chemicals. The SOP used to prepare canister standards is *SOP for Standard Preparation Using Dynamic Flow Dilution System*, ERG-MOR-061 (Appendix C).

11.3 Accuracy and Acceptance

As ambient air measurements encompass a range of compounds and elements whose individual concentrations are unknown, defining absolute accuracy is not possible. Instead, accuracy is determined by comparing the analysis of duplicate samples and of standards of known concentration. The criteria for the analysis of duplicate (or collocated) samples and their replicate analyses are found in Section 4. Accuracy of analysis is based on the accuracy of the calibration, including the accuracy of the calibration standards. Each instrument calibration is discussed by method in Section 13 of this QAPP. Accuracy is monitored throughout the program using QC samples. Required QC samples and their criteria and corrective actions are discussed by the methods listed below.

11.3.1 SNMOC Analysis

Prior to sample analysis for SNMOC, a continuing calibration verification (CCV) standard of hydrocarbons, prepared using either a NIST-traceable Linde or Air Environmental high pressure gas, is analyzed daily to ensure the validity of the current Response Factors (RF). This standard will have an approximate concentration range from 5 ppbC to 400 ppbC. The concentrations are compared to the calculated theoretical concentrations of the CCV. The standard analysis is considered acceptable if the percent recovery is 70-130 percent for 10 selected compounds.

If the CCV does not meet the percent recovery criterion, a second CCV is analyzed. If the second CCV meets the criterion, the analytical system is considered in control. If the second CCV does not meet acceptance criteria, a leak test and system maintenance are performed. Following these maintenance procedures, a third CCV analysis can be performed. If the criterion is met by the third analysis, the analytical system is considered in control. If maintenance causes a change in system response, a new calibration curve is required.

A system blank of cleaned, humidified N₂ is analyzed after the CCV and before the sample analysis. The system is considered in control if the total NMOC concentration for the system blank is less than or equal to 20 ppbC.

CCV requirements are presented in Table 11-1. If both the hydrocarbon and TO-15⁽⁴⁾ parameters are requested from same sample, the instrument must conform to the standard QC procedures listed in both Tables 11-1 and 11-2 (for VOC QC requirements).

11.3.2 VOC Analysis

The tune of the GC/MS is verified using a 4-Bromofluorobenzene (BFB) instrument performance check sample daily. The acceptance criteria for the BFB are presented in Table 11-3. The internal standards for this method are hexane-d₁₄, 1,4-difluorobenzene, and chlorobenzene-d₅. The internal standard responses must be evaluated to ensure instrument stability throughout the day.

Before sample analyses, a standard prepared at approximately 2.5 ppbV from a NIST-traceable Linde or Air Environmental gas cylinder is used for a CCV. The resulting response factor for each compound is compared to the average calibration curve response factors generated from the GC/MS using the Agilent ChemStation[®] Software. Correspondence within an absolute value of less than or equal to 30 percent difference is considered acceptable for the quantitated compounds. If the first CCV does not meet this criterion, a second CCV will be analyzed. If the second CCV is acceptable, sample analysis can continue. If the second CCV does not meet acceptance criteria, then a leak check and system maintenance are performed. If the system maintenance is completed and a third CCV analysis meets the criterion, then analysis may continue. If the maintenance causes a change in the system response, a new calibration curve must be analyzed before sample analyses can begin.

**Table 11-1
 Summary of SNMOC Quality Control Procedures**

QC Check	Frequency	Acceptance Criteria	Corrective Action
Multiple point calibration (5 points minimum); propane, hexane, benzene, octane, and decane bracketing the expected sample concentration. Laboratory Control Standard (LCS) (or Initial Calibration Verification (ICV))	Quarterly	Average Response Factor (RF) curve fit with RF RSD within $\pm 20\%$ ICV Recovery for selected hydrocarbons 70-130%	1) Repeat individual sample analysis 2) Prepare new calibration standards and repeat
Continuing calibration verification (CCV) using Certified Standard	Daily, prior to sample analysis	Recovery for 10 selected hydrocarbons spanning the carbon range 70-130 % ≤ 20 ppbC total	1) Repeat analysis 2) Reprepare and reanalyze 3) Repeat calibration curve
Method Blank Analysis	Daily, following calibration check	≤ 20 ppbC total	1) Repeat analysis 2) Check system for leaks 3) Reanalyze blank
Canister cleaning certification	One canister analyzed on the Air Toxics system per batch of 12	≤ 20 ppbC total	Reclean canisters and reanalyze

**Table 11-2
 Summary of Air Toxics Canister VOC Quality Control Procedures**

QC Check	Frequency	Acceptance Criteria	Corrective Action
BFB Instrument Tune Performance Check	Daily ^b , prior to sample analysis	Evaluation criteria presented in Section 16.1.1 of the SOP and Table 11-3 of this QAPP.	1) Retune 2) Clean ion source and/or quadrupole
Initial calibration (ICAL) consisting of at least 5 points bracketing the expected sample concentration.	Following any major change, repair, or maintenance or if daily QC is not acceptable. Recalibration not to exceed three months.	1) % RSD of Response Factors \leq 30% RSD (with two exceptions of up to \pm 40% for non-Tier I compounds only) 2) Internal Standard (IS) response \pm 40% of mean curve IS response 3) Relative Retention Times (RRTs) for target peaks \pm 0.06 units from mean RRT 4) IS RTs within 20 seconds of mean 5) Each calibration standard concentration must be within \pm 30% of nominal (for Tier I compounds)	1) Repeat individual sample analysis 2) Repeat linearity check 3) Prepare new calibration standards and repeat analysis
LCS ({ICV} Second source calibration verification check)	Following the calibration curve	The response factor \leq 30% Deviation from calibration curve average response factor	1) Repeat calibration check 2) Repeat calibration curve
Continuing Calibration Verification (CCV) of approximately mid-point of the calibration curve ^a using a Certified Standard	Before sample analysis on the days of sample analysis ^b	The response factor \leq 30% Deviation from the calibration curve average RRF (Relative Response Factor)	1) Repeat calibration check 2) Repeat calibration curve

^a The same QA criteria are needed for SNMOC and PAMS analysis.

^b Every 24 hours frequency.

**Table 11-2
 Summary of Air Toxics Canister VOC Quality Control Procedures (Continued)**

QC Check	Frequency	Acceptance Criteria	Corrective Action
Method Blank Analysis (Zero Air or N ₂ Sample Check)	Daily ^b , following BFB and calibration check; prior to sample analysis	1) <3x MDL or 0.2 ppbV, whichever is lower 2) IS area response ± 40% and IS RT ± 0.33 min. of most recent ICAL	1) Repeat analysis with new blank canister 2) Check system for leaks, contamination 3) Reanalyze blank
Duplicate and Replicate Analysis	All duplicate and collocate field samples	<25% RPD for compounds greater than 5 x MDL	1) Repeat sample analysis 2) Flag data in LIMS; Flag in AQS as permitted
Canister Cleaning Certification	One canister analyzed on the Air Toxics system per batch of 12	<3x MDL or 0.2 ppbV, whichever is lower	Reclean canisters and reanalyze
Preconcentrator Leak Check	Each standard and sample canister connected to the preconcentrator/autosampler	≤ 0.2 psi change/minute	1) Retighten and reperform leak check 2) Provide maintenance 2) Re-perform leak check test

^a The same QA criteria are needed for SNMOC and PAMS analysis.

^b Every 24 hours frequency.

**Table 11-2
 Summary of Air Toxics Canister VOC Quality Control Procedures (Continued)**

QC Check	Frequency	Acceptance Criteria	Corrective Action
Sampler Certification - Standard Challenge with a reference can and a Zero Check with a reference can	Annual	Challenge: Within 15% of the concentration in the reference canister. Zero: up to 0.2 ppbV or 3x MDL (whichever is lower) higher than the reference can	1) Repeat certification of samplers, a requirement for Tier I compounds 2) Notify Program Manager (flagging non-Tier I compound data for sampler may be an option)
Sampling Period	All samples	24 hours ± 1 hours	1) Notify Program Manager 2) Flag samples 22-23 hours and 25-26 hours in AQS with a “Y” flag 3) Invalidate and re-sample for > 24±2 hours
Retention Time (RT)	All qualitatively identified compounds	RT within ± 0.06 RRT units of most recent initial calibration average RT	Repeat analysis
Samples – Internal Standards	All samples	IS area response within ± 40% and IS RT within ± 0.33 min. of most recent calibration average IS response	Repeat analysis

^a The same QA criteria are needed for SNMOC and PAMS analysis.

^b Every 24 hours frequency.

Table 11-3. BFB Key Ion Abundance Criteria

Target Mass	Rel. To Mass	Lower Limit %	Upper Limit %
50	95	8	40
75	95	30	66
95	95	100	100
96	95	5	9
173	174	0	2
174*	95	50	120
175	174	4	9
176	174	93	101
177	176	5	9

* alternate base peak

After acceptable analysis of the daily standard has been demonstrated, a system blank consisting of clean, humidified air or N₂ is analyzed. A concentration per compound of < 3x MDL or 0.2 ppbV, whichever is lower (as outlined in Table 11-2) indicates that the system is in control. If a concentration greater than the acceptance criterion is detected, a second system blank is analyzed. If the second system blank fails, system maintenance is performed. Another system blank can be analyzed and if it is in control, ambient air samples are analyzed. All other QC procedure acceptance criteria and corrective actions are presented in Table 11-2.

11.3.3 Carbonyl Compounds Analysis

Daily CCVs prepared from NIST traceable stocks are performed to ensure that the analytical procedures are in control. CCVs are performed every 12 hours or less when samples are analyzed. Compound responses in the CCVs must have a percent recovery between 85-115 percent. Compound retention time drifts are also measured from this analysis and tracked to ensure that the HPLC instruments are operating within acceptable parameters.

If one of these CCV does not meet the criterion, analysis of a second injection of the CCV is performed. If the second CCV does not pass or if more than one CCV does not meet the criterion, a new standard is prepared and analyzed. If it fails a third time, a new calibration curve

(at least 5 concentration levels) is analyzed. All samples analyzed with the unacceptable CCV will be reanalyzed.

Crotonaldehyde tautomerizes into two chromatographically separate peaks after it is spiked onto the DNPH cartridge. The best analytical recovery for crotonaldehyde is determined when both the peaks are integrated together for all samples and QC.

Acetaldehyde elutes with its stereoisomer. The best analytical recovery for acetaldehyde is determined when both peaks are integrated together for all samples and QC.

Acetonitrile system blanks (or solvent blanks) bracket each sequence, with one at the beginning of the sequence and one at the end. The system is considered in control if target compound concentrations are less than the current laboratory MDLs. Quality procedures determined for the carbonyl analysis ensure that ambient air samples are collected in the prescribed manner and that compound quantitative analyses are performed with known bias and precision. The quality procedures for carbonyl analysis are presented in Table 11-4.

11.3.4 PAH Analysis

Every 12 hours, the mass spectrometer used for PAH analysis must have an acceptable Decafluorotriphenylphosphine (DFTPP) instrument performance tune check meeting the criteria listed in Table 11-5 when 1 µL or less of the GC/MS tuning standard, depending on instrument sensitivity, is injected through the GC (50 nanogram (ng) on column).

Samples should be received with filters folded and inserted into the glass thimble cartridge with the sorbent media. It will be noted on the COC and extraction bench sheet if a filter is received in a petri dish, instead of a glass thimble. Prior to sample analyses, a daily CCV must be analyzed, usually a standard prepared at approximately the midpoint of the calibration curve from NIST-traceable PAH stock solution. The resulting response factor for each

**Table 11-4
 Summary of Carbonyl Quality Control Procedures**

Parameter	QC Check	Frequency	Acceptance Criteria	Corrective Action
HPLC Efficiency	Analyze Second Source QC (SSQC) sample	Once per 12 hours or less	1) Resolution between acetone and propionaldehyde ≥ 1.0 2) Column efficiency $> 5,000$ plate counts	1) Eliminate dead volume 2) Back flush 3) Replace the column repeat analysis
DNPH Peak	All samples	Every chromatogram from an extracted cartridge (field sample, method blank, lot blank, and BS/BSD)	DNPH must be $\geq 50\%$ of the DNPH are in the laboratory QC samples	1) Sample concentration will be flagged as estimate (“E”)
Sampler Certification	Zero Challenge cartridge with a reference cartridge	Annual	Each compound must be ≤ 0.2 ppbV above the reference cartridge	1) Repeat certification of samplers, a requirement for Tier I compounds 2) Notify Program Manager (flagging non-Tier I compound data for sampler may be an option)
ICAL	Run a 5-point calibration curve	At setup or when calibration check is out of acceptance criteria (at least every 6 months)	1) Correlation coefficient at least 0.999, relative error for each level against calibration curve $\leq 20\%$ 2) The absolute value of the intercept/slope of the calibration curve must be less than the MDL for each compound	1) Check integration 2) Reanalyze 3) Reprepare standards and recalibrate
ICV	Analyze SSQC sample	After calibration in triplicate	85-115% recovery	1) Check integration 2) Recalibrate 3) Reprepare standard

**Table 11-4
 Summary of Carbonyl Quality Control Procedures (Continued)**

Parameter	QC Check	Frequency	Acceptance Criteria	Corrective Action
Retention Time	Analyze SSQC	Once per 12 hours or less	Each target compound within $\pm 2.5\%$ of the mean calibration standards RT (set in Agilent® software)	<ol style="list-style-type: none"> 1) Check integration, 2) Check for plug in LC 3) Check column temperature in LC
CCV	Analyze SSQC sample	Once per 12 hours or less	85-115% recovery	<ol style="list-style-type: none"> 1) Check integration 2) Reanalyze, reprepare standard, or recalibrate 3) Reanalyze samples not bracketed by acceptable standard
Solvent Blank (aka Continuing calibration blank (CCB), System Blank, or Laboratory Reagent Blank (LRB))	Analyze acetonitrile	Bracket sample batch, 1 at beginning and 1 at end of batch	Measured concentration must be $< \text{MDL}$ for each compound	<ol style="list-style-type: none"> 1) Locate contamination and correct 2) Flag associated data
Sampling Period	All samples	All samples	24 hours \pm 1 hours	<ol style="list-style-type: none"> 1) Notify Program Manager 2) Flag samples 22-23 hours and 25-26 hours in AQS with a “Y” flag 3) Invalidate and re-sample for $> 24 \pm 2$ hours

**Table 11-4
 Summary of Carbonyl Quality Control Procedures (Continued)**

Parameter	QC Check	Frequency	Acceptance Criteria	Corrective Action
Lot Blank Check	Analyze blank for new lots received	Analyze 1.0 % of total lot or a minimum of 3 cartridges, whichever is greater	Compounds must be less than values listed: Formaldehyde <0.15 µg/cartridge (0.03 µg/mL) Acetaldehyde <0.10 µg/cartridge (0.02 µg/mL) Acetone <0.30 µg/cartridge (0.06 µg/mL) Others <0.10 µg/cartridge (0.02 µg/mL)	1) Reanalyze an additional set of cartridges from the new lot 2) Notify vendor if lot blank continues to fail and acquire new lot if possible 3) Flag data associated with bad lot
Extraction Solvent Method Blank (ESMB)	Aliquot of extraction solvent prepared with samples during extraction	First extraction per month and when acetonitrile lot changes	All target compounds must be < MDL	1) Check integration 2) Reanalyze 3) Locate and resolve contamination in extraction glassware/solvent 4) Flag batch data
Field Blank (FB) Check	Field blank samples collected in the field	Monthly (if provided by site)	Underivatized compound concentrations must be less than values listed: Formaldehyde <0.3 µg/cartridge (0.06 µg/mL) Acetaldehyde <0.4 µg/cartridge (0.08 µg/mL) Acetone <0.75 µg/cartridge (0.15 µg/mL) Others <7.0 µg/cartridge (1.4 µg/mL)	1) If FB fails, notify site coordinator, schedule another FB. Additional FBs are collected until the problem is corrected and data are acceptable 2) Flag samples since the last acceptable FB

**Table 11-4
 Summary of Carbonyl Quality Control Procedures (Continued)**

Parameter	QC Check	Frequency	Acceptance Criteria	Corrective Action
Duplicate or Collocate Samples	Analysis of duplicate and collocate samples	As collected (10% of sampling schedule)	≤ 20% RPD for concentrations ≥ 0.5 µg/cartridge	1) Check integration 2) Check instrument function 3) Reanalyze duplicate samples 4) Flag data in LIMS (and AQS as permitted)
Replicate Analyses	Replicate injections	One per batch. Performed on every duplicate and collocate sample or if none available, on a field sample	≤ 10% RPD for concentrations ≥ 0.5 µg/cartridge	1) Check integration 2) Check instrument function 3) Reanalyze sample
MB (BLK)	Analyze MB	One per batch of 20 samples	Underivatized compound concentrations must be less than values listed: Formaldehyde <0.15 µg/cartridge (0.03 µg/mL) Acetaldehyde <0.10 µg/cartridge (0.02 µg/mL) Acetone <0.30 µg/cartridge (0.06 µg/mL) Others <0.10 µg/cartridge (0.02 µg/mL)	1) Reanalyze MB 2) Check extraction procedures 3) Flag batch data

**Table 11-4
 Summary of Carbonyl Quality Control Procedures (Continued)**

Parameter	QC Check	Frequency	Acceptance Criteria	Corrective Action
Blank Spike/Blank Spike Duplicate, (BS/BSD or LCS/LCSD)	Analyze BS/BSD (or LCS/LCSD)	One BS/BSD (LCS/LCSD) per batch of 20 samples	80-120% recovery for Formaldehyde and Acetaldehyde and 70-130% for all other compounds. BSD (LCSD) precision \leq 20% RPD of BS (LCS)	1) Reanalyze BS/BSD (LCS/LCSD) 2) Check calibration 3) Check extraction procedures

Note: Crotonaldehyde tautomerizes into two chromatographically separate peaks after it is spiked onto the DNPH cartridge. The best analytical recovery is determined when both peaks are integrated together for all samples and QC. Acetaldehyde elutes with its stereoisomer. The best analytical recovery for Acetaldehyde is determined when both peaks are integrated together for all samples and QC. Breakthrough cartridges are not submitted or analyzed as specified by Compendium Method TO-11A.

compound will be compared to the average calibration curve response factors. Correspondence within an absolute value of less than or equal to 30 percent difference is considered acceptable. If the first CCV does not meet this criterion, a second CCV will be analyzed. If the second CCV is acceptable, sample analysis can continue. If the second CCV does not meet acceptance criteria, then a leak check and system maintenance are performed. If the system maintenance is completed and a third CCV analysis meets the criterion, then analysis may continue. If the maintenance causes a change in the system response, a new calibration curve must be analyzed before sample analyses can begin.

EPA Compendium Method TO-13A⁽¹⁰⁾ employs and spikes two different types of surrogates. The Field Surrogates, fluoranthene-d₁₀ and benzo(a)pyrene-d₁₂, are spiked onto the PUF media prior to shipment to the field; acceptable recoveries for these field surrogates are in the range of 60 to 120 percent. The laboratory surrogates, fluorene-d₁₀ and pyrene-d₁₀, are spiked into the PUF immediately before extraction; acceptable recoveries for these laboratory surrogates are 60 to 120 percent.

Table 11-5. DFTPP Key Ions and Ion Abundance Criteria

Mass	Ion Abundance Criteria
51	10 to 80% of base peak
68	< 2% of mass 69
69	Present
70	< 2% of mass 69
127	10 to 80% of base peak
197	< 2% of mass 198
198	Base peak (100% relative abundance) or >50% of mass 442
199	5 to 9% of mass 198
275	10 to 60% of base peak
365	> 1.0% of mass 198
441	Present but < 24% of mass 442
442	Base peak, or >50% of mass 198
443	15 to 24% of mass 442

Note: All ion abundances must be normalized to the nominal base peak, 198 or 442. This criterion is based on the tune criteria for Method 8270D.

Internal standard responses and retention times must also be evaluated for stability. The SIM procedures of EPA Compendium Method TO-13A⁽¹⁰⁾ preclude the use of guidelines for qualitative analysis of mass spectra, since complete mass spectra are not acquired when SIM procedures are used. Quantitative analysis for each compound is performed relative to the assigned internal standard. The following internal standard assignments are suggested for PAH analysis are presented in Table 11-6. All method criteria and MQOs for ERG’s PAH analysis are listed in Table 11-7.

Table 11-6. Internal Standards and Associated PAHs

Internal Standard	Associated Compound
Naphthalene-d ₈	Naphthalene
Acenaphthelene-d ₁₀	Acenaphthylene Pyrene Acenaphthene Retene Fluorene Fluoranthene 9-Fluorenone
Phenanthrene-d ₁₀	Phenanthrene Anthracene
Chrysene-d ₁₂	Cyclopenta(c,d)pyrene Benzo(e)pyrene Benz(a)anthracene Benzo(a)pyrene Benzo(b)fluoranthene Chrysene Benzo(k)fluoranthene
Perylene-d ₁₂	Perylene Indeno(1,2,3-cd)pyrene Dibenz(a,h)anthracene Benzo(g,h,i)perylene Coronene

**Table 11-7
 Summary of Quality Control Procedures for Analysis of SVOC Samples for PAHs**

Quality Control Check	Frequency	Acceptance Criteria	Corrective Action
DFTPP instrument tune check	Daily prior to calibration check and sample analysis; every 12 hours if instrument is operated 24 hours/day	Evaluation criteria presented in Section 11, Table 11-5	1) Re-analyze 2) Prepare new tune check standard; analyze 3) Re-tune instrument; reanalyze 4) Clean ion source; re-tune instrument; reanalyze
Solvent Blank (SB)	Prior to ICAL	All target compounds < MDL	1) Reanalyze 2) Perform maintenance on GC; reanalyze
Five-point (minimum) calibration (ICAL)	Following any major change, repair, or maintenance if daily quality control check is not acceptable. Minimum frequency every six weeks	≤ 30% RSD of the RRFs for each compound; Avg Relative Response Factor (RRF) above or equal to minimum RRF limit for each pollutant; ≤ 30% the nominal concentration required for Tier I compounds RRTs within ± 0.06 RRT units of mean RRT of calibration IS RT within ± 20.0 sec of mean RT of calibration	1) Repeat individual calibration standard analyses 2) Check integrations and calculations 3) Prepare new calibration standards and repeat analysis 4) Perform maintenance on GC, especially leak check and repeat analysis 5) Clean ion source and repeat analysis

**Table 11-7
 Summary of Quality Control Procedures for Analysis of SVOC Samples for PAHs (Continued)**

Quality Control Check	Frequency	Acceptance Criteria	Corrective Action
Retention Time (RT)	All qualitatively identified compounds and internal standard	RRT set in software to be no larger than + 0.25 minutes	Repeat analysis
Secondary Source Calibration Verification (SCV)	Immediately after each ICAL	≤ 30% Difference for each compound RRF compared to the mean RRF of the calibration curve.	<ol style="list-style-type: none"> 1) Repeat SCV analysis 2) Check calculations 3) Prepare a new SCV standard and repeat analysis 4) Perform maintenance on GC, especially leak check; reanalyze 5) Clean ion source; reanalyze
Continuing Calibration Verification (CCV) Standard	Daily (or every 12 hours)	Above or equal to RRF minimum and ≤ 30% Difference for each compound RRF compared to the mean RRF of the calibration curve.	<ol style="list-style-type: none"> 1) Repeat individual sample analyses 2) Check calculations 3) Prepare a new CCV standard and repeat analysis 4) Perform maintenance on GC, especially leak check; reanalyze 5) Clean ion source; reanalyze
Solvent Method Blank (SMB)	One with every extraction batch of 20 or fewer field-collected samples.	All target compounds < MDL	<ol style="list-style-type: none"> 1) Check integration 2) Reanalyze 3) Flag samples 4) Remove solvent lot from use
Method Blank (MB)	With every extraction batch ≤ 20 samples	All analytes < 2x MDL	<ol style="list-style-type: none"> 1) Repeat analysis 2) Flag data
Blank Spike (BS) or (LCS) BSD (or LCSD)	One BS (or LCS) with every extraction batch ≤ 20 samples. BSD (or LCSD) once per quarter.	60-120% recovery of nominal for all compounds ≤ 20% RPD compared to BS (or LCS)	<ol style="list-style-type: none"> 1) Repeat analysis 2) Flag data

**Table 11-7
 Summary of Quality Control Procedures for Analysis of SVOC Samples for PAHs (Continued)**

Quality Control Check	Frequency	Acceptance Criteria	Corrective Action
Surrogate compound recoveries: Laboratory surrogates fluorene-d ₁₀ pyrene-d ₁₀ Field Surrogates fluoranthene-d ₁₀ benzo(a)pyrene-d ₁₂	Every sample/blank/BS	60-120% Recovery	<ol style="list-style-type: none"> 1) Repeat analysis 2) Check calculation 3) Flag surrogate data 4) Flag sample data if both field or both lab surrogates fail
Internal Standard Response: naphthalene-d ₈ acenaphthylene-d ₁₀ chrysene-d ₁₂ perylene-d ₁₂	Every sample/blank/BS	Within 50% to 200% of the ISS in the most recent initial calibration CAL4	<ol style="list-style-type: none"> 1) Repeat analysis 2) Invalidate or flag data if unable to reanalyze
Cartridge Lot Blank	One cartridge (and filter) for each batch of prepared cartridges for a particular sample date.	All target compounds \leq 2 times the MDL	<ol style="list-style-type: none"> 1) Repeat analysis 2) Invalidate or flag data if unable to reanalyze prior to cartridge shipment
Field Blank	Monthly (or as provided by site)	Target compounds \leq 5 times the MDL	<ol style="list-style-type: none"> 1) If FB fails, notify site coordinator, schedule another FB. Additional FBs are collected until the problem is corrected and data are acceptable 2) Flag samples since the last acceptable FB when input in AQS
Replicate Analysis	Replicate sample, on each collocate or at a minimum one per sequence	\leq 10% RPD for concentration \geq 0.5 ng/ μ L or lowest cal point, whichever is less.	<ol style="list-style-type: none"> 1) Check integration 2) Check instrument function 3) Reanalyze 4) Flag replicate samples

**Table 11-7
 Summary of Quality Control Procedures for Analysis of SVOC Samples for PAHs (Continued)**

Quality Control Check	Frequency	Acceptance Criteria	Corrective Action
Collocate Samples	Collocated samples, 10% of field samples, or as collected	≤ 20% RPD for concentration ≥ 0.5 ng/μL or lowest ICAL level, whichever is less	1) Check integration 2) Check instrument function 3) Reanalyze 4) Flag collocated samples
Sampling Period	All samples	24 hours ± 1 hours	1) Notify Program Manager 2) Flag samples 22-23 hours and 25-26 hours in AQS with a “Y” flag 3) Invalidate and re-sample for > 24±2 hours

NOTE: Matrix Spikes are not performed as required by Compendium Method TO-13A. Matrix spikes are not required by ASTM D2609.

11.3.5 Metals Analysis

The mass spectrometer used for metals analysis must have an acceptable daily performance check using the tuning solution before each analysis. Daily performance checks are done in both standard and kinetic energy discrimination (KED) mode to verify instrument performance in both modes. Performance specifications are presented in Table 11-8. Analysis of the metals will be performed by ICP-MS for antimony, arsenic, beryllium, cadmium, total chromium, cobalt, lead, manganese, mercury, nickel, and selenium. The internal standards for this method are lithium, scandium, germanium, yttrium, indium, terbium, holmium, and bismuth. Internal standard responses must be evaluated for stability. Gold is added to each of the standards before analysis to prevent the loss of mercury on labware or instrument tubing in the ICP-MS.

Daily calibration, using a calibration blank and at least 5 non-zero standards prepared from NIST-traceable stock solutions, is performed to ensure that the analytical procedures are in control. To be considered acceptable, the calibration curve must have a correlation coefficient ≥ 0.998 . Replicate analysis of the calibration standards must have an RSD ≤ 10 percent, except for the second calibration standard (CAL2). This standard uses the same concentrations as the Limit of Quantitation (LOQ) standard, which are near or less than that of the MDL, therefore an RSD > 10 percent is acceptable. After calibration, an Initial Calibration Verification (ICV), Initial Calibration Blank (ICB), High Standard Verification (HSV), Interference Check Standard A (ICSA), and Interference Check Standard B (ICSAB) are analyzed to ensure quality before the analysis of the samples.

If the initial calibration check does not meet criteria, a second calibration check analysis is performed. If the second set does not pass, or if one or more of the daily QC checks do not meet criteria, a new calibration curve is prepared and analyzed. All samples analyzed with the unacceptable QC check will be reanalyzed or flagged appropriately when necessary. During the analysis of the samples, the Continuing Calibration Verification (CCV) and Continuing Calibration Blank (CCB) are analyzed immediately before the analysis of samples, every 10

samples, and at the end of every analysis batch. The ICSA and ICSAB are analyzed once per analysis day. Quality procedures for metals analysis are shown in Table 11-9.

Table 11-8 Instrument Mass Calibration & Performance Specifications

Parameter	Peak Width	Sensitivity/Criteria*	RSD
iCAP-Q Criteria			
Standard Mode			
Bkg4.5	NA	< 1.0 cps	N/A
7Li	0.65–0.85	> 50,000 cps	< 2% RSD
24Mg	0.65–0.85	> 500,000 cps	< 2% RSD
25Mg	0.65–0.85	> 70,000 cps	< 2% RSD
26Mg	0.65–0.85	> 80,000 cps	< 2% RSD
59Co	0.65–0.85	> 100,000 cps	< 2% RSD
115In	0.65–0.85	> 220,000 cps	< 2% RSD
206Pb	0.65–0.85	> 70,000 cps	< 2% RSD
207Pb	0.65–0.85	> 60,000 cps	< 2% RSD
208Pb	0.65–0.85	> 100,000 cps	< 2% RSD
238U	0.65–0.85	> 300,000 cps	< 2% RSD
140Ce16O/140Ce	NA	< 0.02	N/A
137Ba ⁺⁺ /137Ba ⁺	NA	< 0.03	N/A
Bkg220.7	NA	< 2.0 cps	N/A
Analyzer Pressure	NA	< 10 ⁻⁶ mbar	NA
KED Mode†			
Bkg4.5	NA	< 0.5 cps	N/A
24Mg	0.65–0.85	> 3,000 cps	< 5% RSD
25Mg	0.65–0.85	> 500 cps	< 5% RSD
26Mg	0.65–0.85	> 600 cps	< 5% RSD
59Co	0.65–0.85	> 30,000 cps	< 2% RSD
115In	0.65–0.85	> 30,000 cps	< 2% RSD
206Pb	0.65–0.85	> 60,000 cps	< 2% RSD
207Pb	0.65–0.85	> 50,000 cps	< 2% RSD
208Pb	0.65–0.85	> 80,000 cps	< 2% RSD
238U	0.65–0.85	> 80,000 cps	< 2% RSD
140Ce16O/140Ce	NA	< 0.01	N/A
59Co/35Cl16O	NA	> 18.0	N/A
Bkg220.7	NA	< 2.0 cps	N/A

*cps – Counts per second

† – There are no vacuum requirements for KED mode

Table 11-8 Instrument Mass Calibration & Performance Specifications (Continued)

Parameter	Peak Width	Sensitivity/Criteria*	RSD
iCAP-RQ Criteria			
Standard Mode			
Bkg4.5	NA	< 1.0 cps	N/A
7Li	0.65–0.85	> 55,000 cps	< 2% RSD
24Mg	0.65–0.85	> 500,000 cps	< 2% RSD
25Mg	0.65–0.85	> 80,000 cps	< 2% RSD
26Mg	0.65–0.85	> 100,000 cps	< 2% RSD
59Co	0.65–0.85	> 100,000 cps	< 2% RSD
115In	0.65–0.85	> 240,000 cps	< 2% RSD
206Pb	0.65–0.85	> 80,000 cps	< 2% RSD
207Pb	0.65–0.85	> 70,000 cps	< 2% RSD
208Pb	0.65–0.85	> 160,000 cps	< 2% RSD
238U	0.65–0.85	> 330,000 cps	< 2% RSD
140Ce16O/140Ce	NA	< 0.02	N/A
137Ba ⁺⁺ /137Ba ⁺	NA	< 0.03	N/A
Bkg220.7	NA	< 2.0 cps	N/A
Analyzer Pressure	NA	< 10 ⁻⁶ mbar	NA
KED Mode†			
Bkg4.5	NA	< 0.5 cps	N/A
24Mg	0.65–0.85	> 10,000 cps	< 5% RSD
25Mg	0.65–0.85	> 2,000 cps	< 5% RSD
26Mg	0.65–0.85	> 3,000 cps	< 5% RSD
59Co	0.65–0.85	> 30,000 cps	< 2% RSD
115In	0.65–0.85	> 35,000 cps	< 2% RSD
206Pb	0.65–0.85	> 100,000 cps	< 2% RSD
207Pb	0.65–0.85	> 90,000 cps	< 2% RSD
208Pb	0.65–0.85	> 200,000 cps	< 2% RSD
238U	0.65–0.85	> 85,000 cps	< 2% RSD
140Ce16O/140Ce	NA	< 0.01	N/A
59Co/35Cl16O	NA	> 18.0	N/A
Bkg220.7	NA	< 2.0 cps	N/A

*cps – Counts per second

† – There are no vacuum requirements for KED mode

**Table 11-9
 Summary of Quality Control Procedures for Metals Analysis**

Quality Control Check	Frequency	Acceptance Criteria	Corrective Action
Daily Performance Check (DPR) STD Mode	Before each analysis	See Table 11-8	<ol style="list-style-type: none"> 1) Repeat analysis of DPR 2) Re-optimize instrument tuning parameters 3) Reprepare DPR standard 4) Perform instrument maintenance
Daily Performance Check (DPR) KED Mode	Before each analysis	See Table 11-8	<ol style="list-style-type: none"> 1) Repeat analysis of DPR 2) Re-optimize instrument tuning parameters 3) Reprepare DPR standard 4) Perform instrument maintenance
Initial Calibration Standards (IC)	Daily before each analysis, at least 5 non-zero calibration points and a blank	Correlation coefficient (R) ≥ 0.998 replicate %RSD ≤ 10 . RSDs > 10% are acceptable for the target elements in the CAL2 standard (at LOQ concentration).	<ol style="list-style-type: none"> 1) Repeat analysis of calibration standards 2) Reprepare calibration standards and reanalyze
ICV	Immediately after calibration	Recovery 90-110%	<ol style="list-style-type: none"> 1) Repeat analysis of ICV 2) Reprepare ICV standard 3) Recalibrate and reanalyze
ICB	Immediately after ICV	Absolute value must be < MDL	<ol style="list-style-type: none"> 1) Locate and resolve contamination problems before continuing 2) Reanalyze or recalibrate failing elements for the entire analysis when appropriate
HSV	After ICB and before ICS	Recovery from 95-105%	<ol style="list-style-type: none"> 1) Repeat analysis of HSV 2) Reprepare HSV
ICSA/IFA	Following the HSV	Within ± 3 times LOQ from zero or from the stock standard background contamination when present	<ol style="list-style-type: none"> 1) Repeat analysis of ICSA 2) Reprepare ICSA and analyze 3) Recalibrate or flag failing elements as necessary

**Table 11-9
 Summary of Quality Control Procedures for Metals Analysis (Continued)**

Quality Control Check	Frequency	Acceptance Criteria	Corrective Action
ICSAB/IFB	Following each ICSA	Recovery 80-120% of true value plus standard background contamination when present	1) Repeat analysis of ICSAB 2) Reprepare ICSAB and analyze 3) Recalibrate or flag failing elements as necessary
CCV	Analyze before samples, after every 10 samples, and at the end of each run	Recovery 90-110%	1) Reanalyze CCV 2) Reprepare CCV 3) Recalibrate and reanalyze samples since last acceptable CCV
Low Calibration Verification (LCV)	After the first and last CCV	Recovery 70-130% for Pb only	1) Reanalyze LCV 2) Reprepare LCV 3) Recalibrate and reanalyze samples since last acceptable LCV
CCB	Analyzed after each CCV	Absolute value must be < MDL	1) Reanalyze CCB 2) Reanalyze samples since last acceptable CCB
Laboratory Reagent Blank (LRB)/Blank (BLK1)	1 per batch of ≤ 20 samples	Absolute value must be < MDL	1) Reanalyze for verification 2) If > 5x MDL, failing elements for all batch QC and samples must be flagged 3) When enough sample filter remains (for quartz and glass fiber filters), a reextraction and analysis of the batch should be considered
MB/BLK2	1 per batch of ≤ 20 samples	Absolute value must be < MDL.	Flag the failing elements in the MB. Note: This QC sample is not required by the IO-3.5 method and there is no further corrective action
Standard Reference Material (SRM)	1 per batch of ≤ 20 samples	Recovery 80-120% for Pb only	1) Reanalyze 2) Flag sample data 3) Re-extract batch if possible

**Table 11-9
 Summary of Quality Control Procedures for Metals Analysis (Continued)**

Quality Control Check	Frequency	Acceptance Criteria	Corrective Action
LCS/BS (and LCSD/BSD for 47mm Teflon filters only)	1 per batch of ≤ 20 samples	Recovery 80-120%, $\leq 20\%$ RPD for BS/BSD	1) Reanalyze 2) Flag data if recovery for only one or two elements fail criteria 3) Reprepare sample batch if recovery for most elements fail criteria, when possible
Duplicate (DUPI) (Laboratory Duplicate)	1 per batch of ≤ 20 samples, for quartz/TSP/Glass fiber filters only	$\leq 20\%$ RPD for sample and duplicate values $\geq 5x$ MDL	1) Check for matrix interference in the case of DUP1. 2) Repeat duplicate analysis 3) Flag data
Replicate Analysis (Analytical Duplicate)	1 per batch of ≤ 20 samples	$\leq 20\%$ RPD for sample and duplicate values $\geq 5x$ MDL	1) Repeat replicate analysis 2) Flag data
Collocated Samples (C1/C2)	10% of samples annually (for sites conducting collocated sampling)	$\leq 20\%$ RPD of samples and collocated values $\geq 5x$ MDL	1) Repeat C1 and/or C2 analyses if replicate analyses fail 2) Flag C1 and C2 data if associated replicate reanalyses verify failure
Matrix Spike (MS) and Matrix Spike Duplicate (MSD) for 8x10” Quartz/TSP/Glass fiber filters only	1 per batch of ≤ 20 samples	Recovery 80-120% when the parent sample concentration is less than 4 times the spike concentration. Not applicable to Teflon method	1) Flag data if recovery for only one or two elements fail criteria, or when a matrix interference is confirmed by Serial Dilution (SRD) and/or Post Digestion Spike (PDS) results 2) Reanalyze 3) Reprepare sample batch if recovery for most elements fail criteria or contamination is evident 4) Sb failures must be flagged on MS/MSD and all samples

**Table 11-9
 Summary of Quality Control Procedures for Metals Analysis (Continued)**

Quality Control Check	Frequency	Acceptance Criteria	Corrective Action
MS/MSD RPD for 8x10" Quartz/TSP/Glass filters only	1 per batch of ≤ 20 samples	RPD ≤ 20% Not applicable to Teflon method	1) Check for 4x spike concentration and non-homogenous matrix, flag as necessary 2) Reanalyze for verification
PDS	1 per batch of ≤ 20 samples	Recovery 75%-125%	1) Flag failed elements for parent sample and PDS 2) Reprepare PDS if preparation issue is suspected reason for failure
SRD	1 per batch of ≤ 20 samples	10% RPD of undiluted sample if the element concentration is ≥ 25x MDL	1) Reprepare dilution if preparation issue is suspected reason for failure 2) Flag failed analytes
Field Blank	All Field Blanks as received from field	<5x MDL	1) Flag failed elements in FB
Internal Standards (ISTD)	Every Calibration, QC and Field Sample	Recovery 60-125% of the measured intensity of the calibration blank	1) If drift suspected, stop analysis and determine cause, recalibrate if necessary 2) Reprepare sample 3) If recovery > 125% due to inherent ISTD, dilute sample and reanalyze
Sampling Period	All samples	24 hours ± 1 hours	1) Notify Program Manager 2) Flag samples 22-23 hours and 25-26 hours in AQS with a "Y" flag 3) Invalidate and re-sample for > 24±2 hours

11.3.6 Hexavalent Chromium Analysis

CCVs prepared from NIST-traceable stocks are performed each analysis day to ensure that the analytical procedures are in control. During the analysis of the samples, the ICV and ICB are analyzed immediately before the analysis of samples, a CCV and CCB after every ten injections, and at the end of every analysis batch. The acceptance criteria are between 90-110 percent recovery for the ICVs and CCVs and less than MDL for the ICBs and CCBs.

If these daily CCVs (and/or CCBs) do not meet the criterion, a second analysis of the same standard is performed. If the second CCV does not pass or if more than one daily CCV does not meet the criterion, a new standard is prepared and analyzed. If it fails a third time, a new calibration curve (with at least 5 concentration levels) is analyzed. All samples analyzed with the unacceptable CCV will be reanalyzed. The quality procedures for hexavalent chromium analysis are presented in Table 11-10.

**Table 11-10
 Summary of Quality Control Procedures for Hexavalent Chromium**

QC Check	Frequency	Acceptance Criteria	Corrective Action
Initial 6-point calibration standards	Before every sequence	Correlation coefficient ≥ 0.995 ; Relative Error (RE) $< 20\%$	1) Repeat analysis of calibration standards 2) Reprepare calibration standards and reanalyze
ICV	Before every sequence, following the initial calibration	Recovery 90-110%	1) Repeat analysis of initial calibration verification standard 2) Repeat analysis of calibration standards 3) Reprepare calibration standards and reanalyze
ICB	One per batch, following the ICV	Analyte must be $< \text{MDL}$	1) Reanalyze 2) Reprepare blank and reanalyze 3) Correct contamination and reanalyze blank 4) Flag data of all samples in the batch
CCV	Every 10 injections and at the end of the sequence	Recovery 90-110%	1) Repeat analysis of CCV 2) Reprepare CCV 3) Flag data bracketed by unacceptable CCV
Laboratory Control Sample (LCS/LCSD)	Two per sample batch of ≤ 20 samples	Recovery 90-110%	1) Reanalyze 2) Reprepare standard and reanalyze 3) Flag data of all samples since the last acceptable LCS
MB	One per batch	Analyte must be $\leq \text{MDL}$	1) Reanalyze 2) Flag data for all samples in the batch
Replicate Analysis	Duplicate, Collocate, BS/BSD and/or replicate samples only	$\text{RPD} \leq 20\%$ for concentrations greater than 5 x the MDL	1) Check integration 2) Check instrument function 3) Flag samples
CCB	After every CCV and at the end of the sequence	Analyte must be $< \text{MDL}$	1) Reanalyze 2) Reprepare blank and reanalyze 3) Correct contamination and reanalyze blank 4) Flag data of all samples in the batch

**Table 11-10
 Summary of Quality Control Procedures for Hexavalent Chromium (Continued)**

QC Check	Frequency	Acceptance Criteria	Corrective Action
Retention Time (RT)	For identification of analyte	RT must be within 5% window of the average RT of initial calibration standards	1) Check integration/identification 2) Reanalyze
Sampling Duration	All samples	24 hours ± 1 hours	1) Notify Program Manager 2) Flag samples 22-23 hours and 25-26 hours in AQS with a “Y” flag 3) Invalidate and re-sample for > 24±2 hours

11.4 Precision

Analytical precision is estimated by repeated analysis of approximately 10 percent of the samples. The second analysis is performed in the same analytical batch as the first analysis. Duplicate and collocated samples are reanalyzed once each to determine overall precision, including sampling and analysis variability.

Precision estimates are calculated in terms of absolute percent difference. Because the true concentration of the ambient air sample is unknown, these calculations are relative to the average sample concentration.

Precision is determined as the RPD using the following calculation:

$$\text{RPD} = \frac{|X_1 - X_2|}{\bar{X}} \times 100$$

Where:

- X_1 is the ambient air concentration of a given compound measured in one sample;
- X_2 is the concentration of the same compound measured during duplicate/collocate/replicate analysis; and
- \bar{X} is the arithmetic mean of X_1 and X_2 .

11.5 Completeness

Completeness, a quality measure, is calculated at the end of each year. Percent completeness is calculated as the ratio of the number of valid samples received to the number of scheduled samples (beginning with the first valid field sample received through the last field sample received). This quality measure is presented in the final report. The completeness criteria for all parameters were previously presented in Table 4-1.

Completeness is determined using the following calculation:

$$\text{Completeness} = \frac{\text{Number of valid samples}}{\text{Total expected number of samples}} \times 100$$

11.6 Representativeness

Representativeness measures how well the reported results reflect the actual ambient air concentrations. This measure of quality can be enhanced by ensuring that a representative sampling design is employed. This design includes proper integration over the desired sampling period and following siting criteria established for each task. The experimental design for sample collection should ensure samples are collected at proper times and intervals for their designated purpose per the data quality objectives. For example, SNMOC samples are collected to gain information about PAMS volatile hydrocarbons. Therefore, collection of 3-hour samples from 6:00 a.m. to 9:00 a.m. each weekday is appropriate. Quality measures for duplicate sample collection and replicate analyses are included. ERG is not responsible for the sampling design; therefore, representativeness is beyond the scope of this QAPP. The state and local areas should designate the representativeness following EPA guidelines, however a copy of the 2018 EPA sampling schedule is presented in Appendix B.

11.7 Sensitivity (Method Detection Limits)

Based on changing EPA guidance on MDL determination procedures, the NATTS program has adopted two MDL procedures, a modified Method Update Rule (MUR) for CFR Part 136, Appendix B⁽¹⁹⁾ and the Federal Advisory Committee (FAC) Single Laboratory Procedure (v2.4)⁽²⁰⁾. In the modified MUR, the MDLs are determined using spiked sample and blank sample data, using the larger value for the new MDL. The MDLs determined from spiked samples are verified by analyzing standards at one to four times the newly determined limits. For the FAC, the historic blank sample data is used to determine the MDL and spiked samples are used if the blank data does not meet requirements. VOC, carbonyl, SVOC, metals and hexavalent chromium analyses follow one of the two methods for MDL determination.

For SNMOC and hexavalent chromium (non-NATTS program), the MDLs of the target compounds are determined by analyzing at least seven spiked samples at one concentration on the appropriate collection media (ex.- for SNMOC, 7 spiked samples in 7 individual canisters). The concentration of the spiked samples should be within five times the expected detection limit. The samples should be prepared in a minimum of three different preparation batches and analyzed over 3 non-consecutive days (minimum). This procedure follows the method listed in the 1987 CFR Part 136, Appendix B⁽¹⁹⁾. The MDLs determined from spiked samples are verified by analyzing standards at one to four times the newly determined limits.

The MDL for NMOC has not been determined in 2018. If this method is needed, a detection limit study will be performed before analysis begins. The MDLs for the SNMOC are listed in Table 11-11, for VOCs in Table 11-12, and carbonyl compounds (based on a sample volume of 1000 L) in Table 11-13. The PAH MDLs, based on a sampling volume of 300 m³, are presented in Table 11-14.

Table 11-11. 2018 SNMOC Method Detection Limits

Target Compound	MDL (ppbC)	SQL (ppbC)	Target Compound	MDL (ppbC)	SQL (ppbC)
1,2,3-Trimethylbenzene*	0.172	0.546	Cyclopentene	0.515	1.64
1,2,4-Trimethylbenzene*	0.185	0.588	Ethane*	0.993	3.16
1,3,5-Trimethylbenzene*	0.173	0.549	Ethylbenzene*	0.096	0.305
1,3-Butadiene*	0.123	0.390	Ethylene*	2.35	7.46
1-Butene*	0.125	0.396	Isobutane*	0.051	0.161
1-Decene	0.185	0.588	Isobutene	0.131	0.417
1-Dodecene	0.611	1.943	Isopentane*	0.060	0.191
1-Heptene	0.082	0.262	Isoprene*	0.055	0.176
1-Hexene*	0.085	0.272	Isopropylbenzene*	0.089	0.284
1-Nonene	0.127	0.404	<i>m,p</i> -Xylene*	0.220	0.701
1-Octene	0.096	0.305	<i>m</i> -Diethylbenzene*	0.446	1.42
1-Pentene*	0.060	0.190	Methylcyclohexane*	0.070	0.222
1-Tridecene	0.288	0.914	Methylcyclopentane*	0.115	0.365
1-Undecene	0.390	1.24	<i>m</i> -Ethyltoluene*	0.219	0.696
2,2,3-Trimethylpentane	0.057	0.182	<i>n</i> -Butane*	0.076	0.241

* PAMS compounds

NOTE: MDL's reported are from Instrument 1. New MDLs will be reported for Instrument 4 if required.

Table 11-11. 2018 SNMOC Method Detection Limits

Target Compound	MDL (ppbC)	SQL (ppbC)	Target Compound	MDL (ppbC)	SQL (ppbC)
2,2,4-Trimethylpentane*	0.132	0.419	<i>n</i> -Decane*	0.238	0.755
2,2-Dimethylbutane*	0.084	0.267	<i>n</i> -Dodecane*	0.445	1.41
2,3,4-Trimethylpentane*	0.060	0.190	<i>n</i> -Heptane*	0.075	0.239
2,3-Dimethylbutane*	0.057	0.182	<i>n</i> -Hexane*	0.175	0.558
2,3-Dimethylpentane*	0.119	0.377	<i>n</i> -Nonane*	0.095	0.302
2,4-Dimethylpentane*	0.096	0.305	<i>n</i> -Octane*	0.062	0.197
2-Ethyl-1-butene	0.060	0.190	<i>n</i> -Pentane*	0.081	0.256
2-Methyl-1-Butene	0.089	0.283	<i>n</i> -Propylbenzene*	0.121	0.385
2-Methyl-1-Pentene	0.091	0.288	<i>n</i> -Tridecane	0.296	0.942
2-Methyl-2-Butene	0.287	0.912	<i>n</i> -Undecane*	0.339	1.08
2-Methylheptane*	0.199	0.631	<i>o</i> -Ethyltoluene*	0.152	0.483
2-Methylhexane*	0.136	0.431	<i>o</i> -Xylene*	0.131	0.417
2-Methylpentane*	0.189	0.600	<i>p</i> -Diethylbenzene*	0.191	0.609
3-Methyl-1-Butene	0.222	0.706	<i>p</i> -Ethyltoluene*	0.203	0.644
3-Methylheptane*	0.134	0.426	Propane*	0.611	1.94
3-Methylhexane*	0.262	0.833	Propylene*	0.162	0.515
3-Methylpentane*	0.075	0.239	Propyne	0.056	0.177
4-Methyl-1-Pentene	0.078	0.248	Styrene*	0.246	0.781
Acetylene*	0.044	0.139	Toluene*	0.609	1.94
Benzene*	0.080	0.255	<i>trans</i> -2-Butene*	0.036	0.114
<i>cis</i> -2-Butene*	0.032	0.102	<i>trans</i> -2-Hexene	0.038	0.120
<i>cis</i> -2-Hexene	0.063	0.200	<i>trans</i> -2-Pentene*	0.050	0.159
<i>cis</i> -2-Pentene*	0.055	0.175	α -Pinene*	0.189	0.602
Cyclohexane*	0.081	0.257	β -Pinene*	0.443	1.41
Cyclopentane*	0.055	0.175			

* PAMS compounds

NOTE: MDL's reported are from Instrument 1. New MDLs will be reported for Instrument 4 if required.

Table 11-12. 2018 Air Toxics Method Detection Limits

Target Compounds	MDL (µg/m ³)	SQL (µg/m ³)	Target Compounds	MDL (µg/m ³)	SQL (µg/m ³)
1,1,1-Trichloroethane	0.0750	0.238	<i>cis</i> -1,3-Dichloropropene	0.0894	0.284
1,1,2,2-Tetrachloroethane	0.144	0.457	Dibromochloromethane	0.131	0.417
1,1,2-Trichloroethane	0.104	0.330	Dichlorodifluoromethane	0.135	0.430
1,1-Dichloroethane	0.0578	0.184	Dichlorotetrafluoroethane	0.0938	0.298
1,1-Dichloroethene	0.0473	0.150	Ethyl Acrylate	0.0964	0.306
1,2,4-Trichlorobenzene	1.85	5.89	Ethyl <i>tert</i> -Butyl Ether	0.0458	0.146
1,2,4-Trimethylbenzene	0.132	0.420	Ethylbenzene	0.112	0.357
1,2-Dibromoethane	0.145	0.462	Hexachloro-1,3-Butadiene	0.293	0.931
1,2-Dichloroethane	0.0564	0.179	<i>m,p</i> -Xylene	0.157	0.498
1,2-Dichloropropane	0.0941	0.299	<i>m</i> -Dichlorobenzene	0.110	0.348
1,3,5-Trimethylbenzene	0.167	0.532	Methyl Isobutyl Ketone	0.0975	0.310
1,3-Butadiene*	0.0429	0.136	Methyl Methacrylate	0.411	1.31
Acetonitrile	0.0275	0.0873	Methyl <i>tert</i> -Butyl Ether	0.0371	0.118
Acetylene	0.0421	0.134	Methylene Chloride	0.0500	0.159
Acrolein*	0.516	1.64	<i>n</i> -Octane	0.151	0.481
Acrylonitrile	0.0232	0.0736	<i>o</i> -Dichlorobenzene	0.124	0.394
Benzene*	0.0463	0.147	<i>o</i> -Xylene	0.117	0.371
Bromochloromethane	0.0703	0.223	<i>p</i> -Dichlorobenzene	0.121	0.384
Bromodichloromethane	0.111	0.352	Propylene	0.110	0.351
Bromoform	0.183	0.583	Styrene	0.155	0.493
Bromomethane	0.0448	0.143	<i>tert</i> -Amyl Methyl Ether	0.0518	0.165
Carbon Disulfide	0.239	0.762	Tetrachloroethylene*	0.0992	0.315
Carbon Tetrachloride*	0.0840	0.267	Toluene	0.493	1.57
Chlorobenzene	0.0887	0.282	<i>trans</i> -1,2-Dichloroethylene	0.0533	0.169
Chloroethane	0.0659	0.209	<i>trans</i> -1,3-Dichloropropene	0.0807	0.257
Chloroform*	0.0633	0.201	Trichloroethylene*	0.0806	0.256
Chloromethane	0.0961	0.306	Trichlorofluoromethane	0.0654	0.208
Chloroprene	0.0469	0.149	Trichlorotrifluoroethane	0.0749	0.238
<i>cis</i> -1,2-Dichloroethylene	0.0740	0.235	Vinyl Chloride*	0.0327	0.104

*NATTS Tier I compounds

**Table 11-13. 2018 Carbonyl Method Detection Limits
 (Underivatized Concentration)**

Compound	MDL ($\mu\text{g}/\text{m}^3$)	SQL ($\mu\text{g}/\text{m}^3$)
2,5-Dimethylbenzaldehyde	0.0163	0.05171
2-Butanone (Methyl Ethyl Ketone)	0.136	0.432
Acetaldehyde *	0.0389	0.124
Acetone	0.408	1.30
Benzaldehyde	0.00952	0.03029
Butyraldehyde	0.0576	0.183
Crotonaldehyde	0.00809	0.02571
Formaldehyde *	0.0739	0.235
Hexaldehyde	0.00742	0.02361
Isovaleraldehyde	0.0112	0.03565
Propionaldehyde	0.00469	0.01493
Tolualdehydes	0.0169	0.05361
Valeraldehyde	0.00746	0.02372

NOTE: Assumes 1000 L sample volume. MDLs determined in June 2018.

*NATTS Tier I compounds

Table 11-14. 2018 PAH Method Detection Limits

Compounds	MDL (ng/m ³)	SQL (ng/m ³)
9-Fluorenone	0.0607	0.193
Acenaphthene	0.0743	0.236
Acenaphthylene	0.0147	0.0466
Anthracene	0.0134	0.0426
Benzo(a)anthracene	0.0104	0.0330
Benzo(a)pyrene *	0.0106	0.0337
Benzo(b)fluoranthene	0.0213	0.0677
Benzo(e)pyrene	0.0105	0.0334
Benzo(g,h,i)perylene	0.0130	0.0413
Benzo(k)fluoranthene	0.0116	0.0369
Chrysene	0.00805	0.0256
Coronene	0.00467	0.0148
Cyclopenta(c,d)pyrene	0.00711	0.0226
Dibenz(a,h)anthracene	0.0150	0.0477
Fluoranthene	0.0248	0.0790
Fluorene	0.0693	0.220
Indeno(1,2,3-cd)pyrene	0.0133	0.0424
Naphthalene *	1.82	5.77
Perylene	0.00929	0.0295
Phenanthrene	0.125	0.398
Pyrene	0.0126	0.0400
Retene	0.0617	0.196

NOTE: Assumes a 300 m³ sample volume. MDLs determined in May 2018.

*NATTS Tier I compounds

Two MDLs are determined for the metals analysis. One is determined for quartz filters, and the other for Teflon filters. The detection limits for metals the determined by the FAC⁽²⁰⁾ method using compiled method blank data. If the resulting MDL for any element does not meet criteria, then seven to 10 replicate blank filter strips should be spiked at a concentration of two to five times the estimated MDL, digested, and analyzed to determine the MDL values using the method described in 40 CFR Part 136⁽¹⁸⁾, Appendix B. Both procedures should be prepared

following the entire analytical method procedure. The metals MDLs are shown in Table 11-15 and are based on a sampling volume of 2000 m³ for the quartz filters and 24.04 m³ for the Teflon filters. For 2018, the FACA procedure was used to determine the MDLs for the quartz and Teflon filters. The hexavalent chromium MDL is also included in Table 11-15 and is based on a sampling volume of 21.6 m³.

The Sample Quantitation Limit (SQL) is also reported in Table 11-13 through Table 11-15. The SQL is defined as the lowest concentration an analyte can be reliably measured within specified limits of precision and bias during routine laboratory operating conditions. The SQL is defined by EPA as a multiplier (3.18) of the MDL and is considered the lowest concentration that can be accurately measured, as opposed to just detected. ERG submits this data into AQS using flags to show where the data is in respect to the detection level.

The NATTS Program requires sampling and analysis for 18 target air toxic analytes. Hexavalent chromium is no longer required by the NATTS program, but was given a target MDL in the latest NATTS TAD⁽¹⁸⁾ and the NATTS Work Plan Template⁽²¹⁾. The NATTS program uses sensitivity to assess quantification from a monitoring site with the appropriate level of certainty. In order to meet this objective, target MDLs have been established for the NATTS Program and are compared to the current 2018 ERG MDLs in Table 11-16.

Table 11-15. 2018 Metals Method Detection Limit

Element	47 mm Teflon		8x10" Quartz	
	MDL (ng/m ³)	SQL (ng/m ³)	MDL (ng/m ³)	SQL (ng/m ³)
Antimony *	0.151	0.479	0.0336	0.107
Arsenic *	0.0362	0.115	0.00879	0.0280
Beryllium *	0.00142	0.00453	0.00130	0.00414
Cadmium *	0.00487	0.0155	0.00544	0.0173
Chromium *	3.27	10.4	1.13	3.61
Cobalt *	0.0842	0.268	0.0183	0.0582
Lead *	0.0657	0.209	0.0855	0.272
Manganese *	0.194	0.616	0.816	2.60
Mercury	0.0153	0.0485	0.00498	0.0158
Nickel *	1.21	3.85	0.436	1.39
Selenium *	0.0582	0.185	0.0101	0.0321
Hexavalent Chromium MDL (47mm Cellulose)				
Hexavalent Chromium	0.0040	0.0127		

NOTE: For total metals: Assumes total volume of 24.04 m³ for Teflon filters and 2000 m³ for Quartz filters.

For hexavalent chromium: Assumes total volume of 21.6 m³.

*NATTS Tier I Compounds

Table 11-16. Target MDLs for the NATTS Program

Pollutant	NATTS Target MDL (µg/m ³)	ERG 2018 MDL (µg/m ³)	Is ERG MDL < Target MDL?		
<i>NATTS Tier I VOC HAPs</i>					
Acrolein	0.09	0.516	NO		
Benzene	0.13	0.0463	YES		
1,3-Butadiene	0.10	0.0429	YES		
Carbon Tetrachloride	0.17	0.0840	YES		
Chloroform	0.50	0.0633	YES		
Tetrachloroethylene	0.17	0.0992	YES		
Trichloroethylene	0.20	0.0806	YES		
Vinyl Chloride	0.11	0.0327	YES		
<i>NATTS Tier I Carbonyl HAPs</i>					
Acetaldehyde	0.45	0.0389	YES		
Formaldehyde	0.080	0.0739	YES		
<i>NATTS Tier I PAH HAPs</i>					
Benzo(a)pyrene	0.91	0.0106	YES		
Naphthalene	29	1.82	YES		
<i>NATTS Tier I Metal HAPs</i>					
				<i>(Low Vol PM₁₀)</i>	<i>(High Vol PM₁₀)</i>
Arsenic (PM ₁₀)	0.23	0.0362	YES	0.00879	YES
Beryllium (PM ₁₀)	0.42	0.00142	YES	0.00130	YES
Cadmium (PM ₁₀)	0.56	0.00487	YES	0.00544	YES
Lead (PM ₁₀)	15.0	0.0657	YES	0.0855	YES
Manganese (PM ₁₀)	5.0	0.194	YES	0.816	YES
Nickel (PM ₁₀)	2.1	1.21	YES	0.436	YES

NOTE: Target MDL's were obtained from the NATTS Work Plan Template (March 2015), Section 3.1 and the NATTS TAD, Revision 3⁽¹⁸⁾

SECTION 12
INSTRUMENT/EQUIPMENT TESTING, INSPECTION, AND MAINTENANCE
REQUIREMENTS

To ensure the quality of the sampling and analytical equipment, ERG conducts performance checks for all equipment used in each of the programs. ERG checks the sampling systems annually, and makes repairs as needed. ERG tracks the performance of the analytical instrumentation to ensure proper operation. ERG also maintains a spare parts inventory to shorten equipment downtime. Table 12-1 details the maintenance items, how frequently they will be performed, and who is responsible for performing the maintenance. All checks, testing, inspections, and maintenance done on each instrument are recorded in the appropriate Maintenance Logbook or LIMS Instrument Maintenance Logs for each instrument.

Table 12-1
Preventive Maintenance in ERG Laboratories

Item	Maintenance Frequency	Responsible Party
For Analytical Systems		
Multipoint Calibration	As needed or at least at intervals specified in Section 11	Analyst
Comparison to Continuing Calibration Standard	Daily	Analyst
Replace GC/LC/IC Column	As necessary (i.e., observe peaks tailing, retention time shifts, increased baseline noise, etc.)	Analyst
Detector Maintenance	As necessary	Analyst
Computer Backup	Biweekly, Daily preferred	Analyst
Accelerated Solvent Extractor		
Piston Rinse Seal	Quarterly, or as needed	Analyst
Standard Rinse Seal	Quarterly, or as needed	Analyst

**Table 12-1
 Preventive Maintenance in ERG Laboratories (Continued)**

Item	Maintenance Frequency	Responsible Party
High Performance Liquid Chromatography		
In-line filter	As necessary (when pressure increases above 2500 psi)	Analyst
Inspect Delivery System Motor	Annually	Service Technician
Replace Teflon Delivery Tubing	Annually	Service Technician
Ion Chromatography		
Rinse Post Column Reagent lines with methanol	As necessary	Analyst
Rinse Eluent Lines with Deionized water	After every sequence	Analyst
Sonicate Inlet and Outlet Check Valves	As necessary	Analyst
Rinse Autosampler Injector	As necessary	Analyst
Inorganic Laboratory		
Flush system for 5 minutes with the plasma on with a rinse blank	After every sequence	Analyst
Cleaning cones, torch, injector, spray chamber	Quarterly, or as needed for analysis quality	Analyst
Change Roughing Pump Oil	Annually	Service Engineer
Replace Air Filters	Annually	Service Engineer
For Sampling Field Equipment (UATMP, Carbonyl, NMOC/SNMOC, and Hexavalent Chromium)		
Inspect/Replace vacuum pump diaphragms and flapper valves	At each system certification effort	ERG
Inspect Sampler (overall)	At each system certification effort and prior to each scheduled collection event	ERG/Field Operator
Inspect/Replace Cartridge Connectors	Prior to each collection event, replace as needed	ERG/Field Operator
Replace Ozone Scrubber	At each system certification effort	ERG
MFM Check or Flow check	At each system certification effort	ERG
Inspect/Replace Fans	At each system certification effort	ERG

12.1 SNMOC, VOC, and PAMS

The GC/FID/MS systems are maintained under a service agreement. ERG personnel perform minor maintenance, such as filament changes, carrier gas filter replacements, column maintenance, and source cleaning. The following spare parts should be kept in the lab: traps, filament, column, and split for the column. All procedures, checks, and scheduled maintenance checks for VOC GC/FID/MS analysis are provided in ERG's SOP (ERG-MOR-005) presented in Appendix C.

12.2 Carbonyls

The carbonyl HPLC analytical systems are maintained under a service agreement. ERG personnel perform minor maintenance, such as column and detector maintenance, on an as-needed basis. The following spare parts should be kept in the lab: solvent frit, column, in-line filter and guard column. All procedures, checks, and scheduled maintenance checks are provided for carbonyl HPLC analysis in ERG's SOP (ERG-MOR-024) presented in Appendix C.

12.3 HAPs

The GC/MS systems for PAH and VOC analysis are maintained under the same service agreement. ERG personnel perform minor maintenance as needed. The following spare parts should be kept in the lab: injector sleeve, filament, and column.

For the HAPs sample analyses performed on the ICP-MS and IC, routine preventive maintenance is performed by the Analyst or Task Lead. ERG personnel perform minor maintenance, such as column and detector maintenance, on an as-needed basis. Contracted service agreements are in place for non-routine maintenance. Spare pump tubing, focusing lens, gem tips, and o-rings should be kept in the lab for the ICP-MS. A spare guard and analytical column, piston seals, reaction coil, and reservoir frits should be kept in the lab for the IC. More procedures, checks, and scheduled maintenance checks are provided in ERG's SOP

Project No.	0344.00
Element No.	Section 12 - B6
Revision No.	4
Date	February 2018
Page	4 of 4

(ERG-MOR-049) for PAH analysis by GC/MS, ERG-MOR-095 for metals analysis by ICP-MS, and ERG-MOR-063 for hexavalent chromium by IC presented in Appendix C.

SECTION 13

INSTRUMENT CALIBRATION AND FREQUENCY

The programs are discussed separately in this section because the requirements for analytical system calibrations differ. Analytical instruments and equipment are calibrated when the analysis is set up, when the laboratory takes corrective action, following major instrument maintenance, or if the continuing calibration acceptance criteria have not been met. Appropriate standards are prepared by serial dilutions of pure substances or accurately prepared concentrated solutions. Many analytical instruments have high sensitivity, so calibration standards must be extremely dilute solutions. In preparing stock solutions of calibration standards, great care is exercised in measuring weights and volumes, since analyses following the calibration are based on the accuracy of the calibration.

Each calibration analysis is stored, electronically and hardcopy, with traceability for the samples analyzed using that calibration. Each of the analytical systems is calibrated for all reported target analytes, except for the NMOC and SNMOC calibrations. The NMOC calibration is based on propane and the SNMOC calibration is based on propane, hexane, benzene, octane, and decane average response factors. NMOC calibration will be discussed in more detail when the analysis is requested by a State.

13.1 SNMOC Calibration

For the SNMOC method, average carbon response factors are obtained quarterly (at a minimum) based on the analysis of humidified calibration standards prepared in canisters. The Dynamic Flow Dilution System (SOP Number ERG-MOR-061, Appendix C) is used to dilute certified Linde or equivalent alkanes into clean, evacuated SUMMA[®]- treated canisters. The gas standards are traceable via the gravimetric preparation using NIST-traceable weights. These gas standards are recertified annually. HPLC grade water is used to humidify the standard to approximately 50 percent. The standard is diluted with scientific-grade air to achieve the desired concentrations for the calibration. The response factors generated from the calibration are used to

determine concentrations of detected compounds, on the assumption that FID response is linear with respect to the number of carbon atoms present in the compound.

At least five calibration standards are prepared in ranges from 5 to 400 ppbC concentrations. The average response factors for propane, hexane, benzene, octane, and decane are determined using the response correlated to concentration. Individual concentrations for the C₂ through C₁₃ compounds detected on the FID are calculated using one of the five response factors, with a similar Carbon number. The calibration is considered representative if the average RF RSD for the curve is within ± 20 percent. Daily, before sample analysis, a CCV standard (such as Air Environmental gas standard), is analyzed to ensure the validity of the current response factors. Ten selected hydrocarbons, ranging from C₂ through C₁₀, from the QC standard are compared to the calculated theoretical concentrations. A percent recovery of 70-130 percent is considered acceptable showing the analytical system is in control.

A blank of cleaned, humidified air or N₂ is analyzed after the CCV and before sample analyses. The system is considered in control if the total NMOC concentration for the blank is less than or equal to 20 ppbC.

13.2 VOC Calibration

Calibration of the GC/FID/MS is accomplished quarterly (at a minimum) by analyzing humidified calibration standards prepared in canisters generated from NIST-traceable Linde or Air Environmental (or equivalent) gas standards. The certified standards contain the VOC target compounds at approximately 500 ppbV. Although the MS is the primary quantitation tool, responses on the FID are recorded to detect and quantify hydrocarbon peaks and can be used for SNMOC or PAMS results. The calibration for these hydrocarbon peaks should be accomplished as explained in Section 13.1.

Calibration standards are prepared with a dynamic flow dilution apparatus (Figure 13-1, see Standard Operating Procedure ERG-MOR-061, Appendix C). The gases are mixed in a SUMMA[®]-treated mixing sphere and bled into evacuated canisters. One dilution air stream is humidified by routing it through a SUMMA[®]-treated bubbler containing HPLC-grade water; the other stream is not humidified. The dilution air streams are then brought together for mixing with the streams from the certified cylinders. Flow rates from all streams are gauged and controlled by mass flow controllers. The split air dilution streams are metered by “wet” and “dry” rotameters (~50 percent relative humidity) from the humidified and unhumidified dilution air streams, respectively.

The system is evacuated with a vacuum pump while the closed canister is connected. The lines leading to the canister and to the mixing sphere are flushed for at least 20 minutes with standard gas before being connected to the canister for filling. A precision pressure gauge measures the canister pressure before and after filling.

Initial calibration standards are prepared at nominal concentrations of 0.25, 0.5, 1, 2.5, 5, and 10 ppbV for each of the target compounds (a minimum of 5 levels are required). All standards and samples are analyzed with the following internal standards: *n*-hexane-d₁₄, 1,4-difluorobenzene, and chlorobenzene-d₅. The calibration requires average response factors, based on the internal standard, of ± 30 percent RSD, however per Compendium Method TO-15⁽⁴⁾ acceptance criteria, up to two compounds can have ± 40 percent RSD (non-Tier I compounds). The CCV is made from a second source certified gas at an average concentration of 2.5 ppbV. The CCV must have RRFs within ± 30% of the mean initial calibration RRFs.

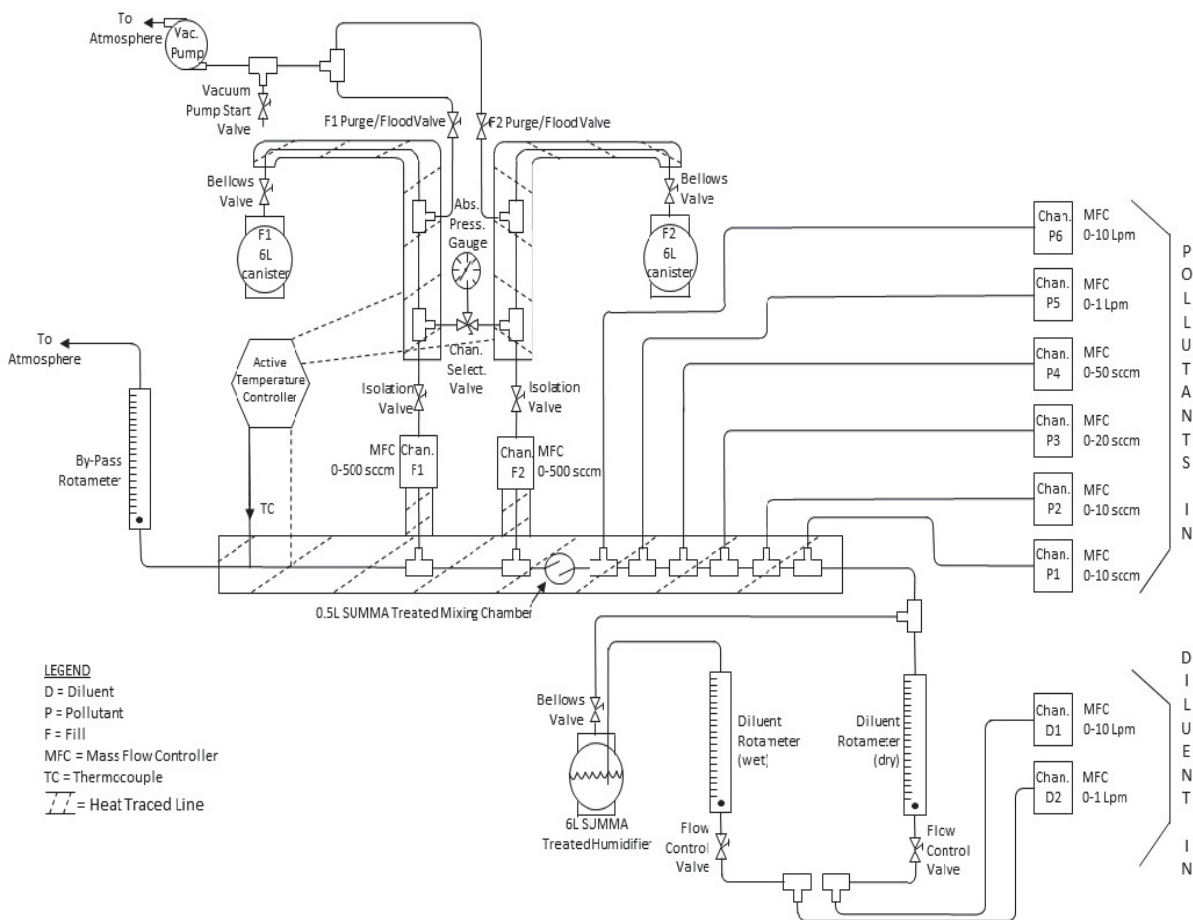

Figure 13-1. Dynamic Flow Dilution Apparatus

13.3 Carbonyl Calibration

For the carbonyl analyses, the HPLC instrument is calibrated using an acetonitrile solution containing the derivatized targeted compounds. The calibration curve consists of six concentration levels ranging from 0.01 to 3.0 microgram per milliliter ($\mu\text{g}/\text{mL}$) (underivatized concentration), and each is analyzed in triplicate. The standard linear regression analysis performed on the data for each analyte must have a correlation coefficient greater than or equal to 0.999. The Relative Error (RE) for each compound at each level against the calibration curve must be ≤ 20 percent. As a QC procedure to verify the calibration and check HPLC column efficiency, a SSQC sample solution containing target carbonyl compounds at a known concentration is analyzed in triplicate after every calibration curve, with an 85-115 percent recovery criterion.

In each sequence, a CCV (a second source standard) is analyzed every 12 hours or less while samples are analyzed (meeting the 85-115 percent recovery criterion). A system blank brackets the analytical batch, by analyzing one blank at the beginning and one at the end of each sequence.

13.4 HAPs Calibration

The GC/MS system in SIM mode is calibrated for PAH analysis at a minimum every six week. The average calibration RRF must be greater than or equal to the minimum RRF presented in Table 13-1. For the other HAPs sample analyses, calibration is performed on the ICP-MS and IC. Calibration requirements for the HAPs analytical methods are in Tables 11-7, 11-9 and 11-10.

**Table 13-1.
Relative Response Factor Criteria for Initial Calibration of Common Semivolatile Compounds**

Semivolatile Compounds	Minimum RRF	Maximum %RSD	Maximum % Difference
Naphthalene	0.700	30	30
Acenaphthylene	1.300	30	30
Acenaphthene	0.800	30	30
Fluorene	0.900	30	30
Phenanthrene	0.700	30	30
Anthracene	0.700	30	30
Fluoranthene	0.600	30	30
Pyrene	0.600	30	30
Benz(a)anthracene	0.800	30	30
Chrysene	0.700	30	30
Benzo(b)fluoranthene	0.700	30	30

Note – The ASTM method includes no minimum RRF criteria, therefore none are listed here for the ASTM⁽¹²⁾ compounds.

**Table 13-1.
 Relative Response Factor Criteria for Initial Calibration of Common Semivolatile
 Compounds (Continued)**

Semivolatile Compounds	Minimum RRF	Maximum %RSD	Maximum % Difference
Benzo(k)fluoranthene	0.700	30	30
Benzo(a)pyrene	0.700	30	30
Indeno(1,2,3-cd)pyrene	0.500	30	30
Dibenz(a,h)anthracene	0.400	30	30
Benzo(g,h,i)perylene	0.500	30	30
Perylene	0.500	30	30
Coronene	0.700	30	30
Benzo(e)pyrene	--	30	30
Cyclopenta(c,d)pyrene	--	30	30
Retene	--	30	30
9-Fluorenone	--	30	30

Note – The ASTM method includes no minimum RRF criteria, therefore none are listed here for the ASTM⁽¹²⁾ compounds.

13.5 Laboratory Support Equipment Calibration

Analytical balances are serviced and calibrated annually with NIST traceable weights by a vendor service technician. The certificate of Weight Verification (ISO9001) is kept on file by the QA Coordinator. The balance calibrations are checked daily on days of use with Class 1 weights and recorded. The data loggers used for temperature/humidity/pressure have calibration checks annually performed by the vendor. The infrared (IR) thermometers are annually vendor calibrated with NIST-traceable standards. The calibration of the thermometers used in the metals sample digestion procedure are checked against a thermometer with a NIST traceable vendor calibration. The pressure gauges used for measuring sample canister pressure at receipt are calibrated annually by a certified vendor. Other pressure gauges, used in canister cleaning or canister sample dilution, are checked against a “transfer standard” gauge that is calibrated annually by a certified vendor. MFCs used in the canister dynamic dilution standard system are calibrated annually and the calibrations are checked quarterly.

Pipette calibrations are checked and recorded quarterly. If a pipette fails a calibration check they are rechecked. If it continues to fail, it is sent back to the manufacturer for recalibration. If recalibration is not possible it will be repaired or replaced with a new pipette. Syringe calibrations are checked and recorded annually. If a syringe fails the calibration check, it will be replaced with a new one. Class A volumetric glassware is used throughout the laboratory for bringing sample extracts up to final volume.

SECTION 14

INSPECTION/ACCEPTANCE FOR SUPPLIES AND CONSUMABLES

14.1 Purpose

The purpose of this element is to establish and document a system for inspecting and accepting all supplies and consumables that may directly or indirectly affect the quality of the NMP. By having documented inspection and acceptance criteria, consistency of the supplies can be assured. This section details the supplies/consumables, their acceptance criteria, and the required documentation for tracing this process.

14.2 Critical Supplies and Consumables

Table 14-1 details the various components for the field and laboratory operations.

14.3 Acceptance Criteria

Acceptance criteria for supplies/consumables must be consistent with overall project technical and quality criteria. As requirements change, so do the acceptance criteria. Knowledge of laboratory equipment and experience are the best guides to acceptance criteria. It is the laboratory analyst's responsibility to update the criteria for acceptance of consumables. Other acceptance criteria such as observation of damage due to shipping can only be performed once the equipment has arrived on site.

All supplies and consumables are inspected and accepted or rejected upon receipt in the laboratory. The ERG employee who ordered the supply is responsible for verifying that the order is acceptably delivered, stored and dispersed upon receipt in the laboratory. The recipient's signature on the packing slip indicates the received goods were received and are acceptable. Some supplies or consumables listed in Table 14-1 must be deemed acceptable through testing or blanking, such as with the carbonyl DNPH cartridges. Any changes in standards and sample

media must meet the acceptance criteria outlined in Section 11 for that particular method. Such testing and blanking data is kept with the sample data. Staff should not use supplies or consumables of different model numbers or grades without first discussing it with the Program Manager and specific Task Leader and testing the supply or consumable. Staff should keep any certificate of analysis or cleanliness that arrives with the supply/consumable on file. For specific information on reagents and standards used, see applicable method SOP.

**Table 14-1
Critical Supplies and Consumables**

Area	Item	Description	Vendor	Model Number
Field Supplies and Consumables (Fabrication Lab)				
All Samplers	Various Swagelok® fittings	All Samplers	Swagelok	Various
NMOC Sampler	Pump	Metal Bellows	KNF Newberger	UN 05-SV.91
VOC Sampler	Vacuum Pump	VOC System	Thomas	2107VA20
	Canisters	VOC Canisters	Entech	6-liter Silonite® Canisters
Carbonyl Sampler	DNPH Cartridges	DNPH coated plastic cartridges	Waters	WAT 037500
Hexavalent Chromium Sampler	Pump	High Vacuum	Thomas	VA-2110
Laboratory Supplies and Consumables (Laboratories listed below)				
All Laboratories	Powder Free Gloves	Polyethylene	VWR	32915-246
All Laboratories	Gloves	Nitrile	Expotech, ThermoFisher, VWR	1461558 (Expotech)
Liquid Chromatography	Guard column	Zorbax ODS	Agilent	820950-902
Liquid Chromatography	Chromatographic Column	Zorbax ODS	Agilent	880952-702
Liquid Chromatography	UV Lamp	For 2487 detector	Waters	WA 5081142
GC/MS – VOC	Chromatographic Column	0.32 x 1 μ - 60 m column	Restek	Rxi-1ms
GC/MS – SVOC	Chromatographic Column	0.25 x 0.25 μ - 30 m column	Agilent J&W	HP-5MS UI
GC/MS – SVOC	Inject seal	Injection port seal	Expotech	2264837
GC/MS – SVOC	Liner	Injection port liner	Expotech	2377232

**Table 14-1
 Critical Supplies and Consumables (Continued)**

Area	Item	Description	Vendor	Model Number
GC/MS & Liquid Chromatography	Helium	Carrier Gas	Air Gas	UHP
GC/MS	Hydrogen Gas	FID Gas	Air Gas	UHP
GC/MS	Liquid Nitrogen	Coolant Gas	Air Gas	Bulk
GC/MS	Liquid Argon	Coolant Gas	Air Gas	Bulk
GC/MS	Air	FID Gas	Air Gas	Zero
GC/MS	Traps	Glass bead/Tenax Trap	Entech	01-04-11340
GC/MS	Trap Heater	Sample Trap Heater	Entech	01-09-13010
GC/MS	Cryogenic Valve	Cryogenic Valve	Entech	01-01-71760
ICP-MS	Liquid Argon	Coolant Gas	Air Gas	Bulk
ICP-MS	Acid	High Purity Nitric	Fisher/SCP Science	A200-212/Plasma Pure Plus
ICP-MS	Acid	Hydrochloric Acid	Fisher/SCP Science	A466-1/Plasma Pure Plus
ICP-MS	Hydrogen Peroxide	Hydrogen Peroxide, 30%	SCP Science	Plasma Pure Plus
ICP-MS	Whatman 8"x11" Quartz/Glass Fiber Filters MTL 47mm Teflon™ Filters	Filters	GE Healthcare Life Sciences & MTL	1851-8531 1882-8532 PT47-EP
IC	Reaction Coil	Knitted Reaction Coil	ThermoFisher	042631
IC	Guard Column	Dionex Ion Pac NG1	ThermoFisher	039567
IC	Analytical Column	Dionex Ion Pac AS7	ThermoFisher	035393
IC	Methanol	Solvent	Expotech, Fisher, VWR	HPLC grade
IC	Sample vials 14 mL, polystyrene with caps	Sample containers	ThermoFisher	352057
IC	Whatman Filters	Filters—47mm ashless cellulose	Expotech, Fisher	09-850H
Prep	Water Filter	Ultrapure Ion Exchange Cartridge	Expotech	1425973
Prep	Water Filter	Cartridge submicron	Expotech	1425977
Prep	Water Filter	Pretreatment Cartridge	Expotech	1426051
Prep	Whatman Filters	Filters—110mm GFA	Expotech	1422153

**Table 14-1
Critical Supplies and Consumables (Continued)**

Area	Item	Description	Vendor	Model Number
Prep	PUF	Pre-cleaned PUF	Cen-Med, Expotech	824-20038, 2256468
Prep	XAD®	XAD®	Expotech	2255045
Prep	Petri Dish	Filter container	Expotech	1426833
Prep	Acetonitrile	Solvent	Expotech, Fisher, VWR	HPLC grade
Prep	Methylene Chloride	Solvent	Expotech, Fisher, VWR	Optima grade
Prep	Hexane	Solvent	Expotech, Fisher, VWR	95% (Optima grade)
Prep	Toluene	Solvent	Expotech, Fisher, VWR	Optima Grade
Prep	Nitrogen	Evaporation gas	Air Gas	UHP (or Bulk)
Prep	Amber glass bottles 250 mL	Sample containers	Expotech	2373176
Prep	Extraction cells	Sample containers	Thermo Electron	068077
Prep	Ottawa sand	Extraction filler	Expotech	2262138
Prep	Seals	ASE Vespel Seals	Fisher	056776
Prep	Disposable pipets	Disposable pipets	Expotech	1405717
Prep	4 mL amber sample vials	Sample containers	Expotech, Fisher, VWR	66030-734 (VWR)
Prep	4 mL sample Teflon lined caps	Sample containers	Expotech, Fisher, VWR	66030-771 (VWR)
Prep	Autosampler snap-it vials	Sample containers	Waters	WAT 094220
Prep	Autosampler snap-it caps	Sample containers	Waters	18000303

Consumables and supplies with special handling and storage needs must be handled and stored as suggested by the manufacturer. Consumables with expiration dates, such as solvents and standards, must be labeled with a receipt date, date opened, and the initials of the person that opened the consumable and standard expiration dates must be entered into the standards section of LIMS. To decrease waste, the oldest supplies or consumables should be used first.

SECTION 15

DATA MANAGEMENT

15.1 Data Recording

Data management for sample data is presented in Figure 15-1. The sample data path is shown from sample origination to data reporting and storage. The LIMS allows the laboratory to manage and track samples, instrument workflow, and reporting. The LIMS stores the raw instrument data and performs the conversion calculations to put the data into final reporting units. These calculations are reviewed and documented annually by the QA coordinator and kept in the QA files in Room 102. The main procedures are described in the *SOP for the Laboratory Information Management System* (ERG-MOR-099). The main functions of the LIMS system include, but are not limited to:

- Sample login;
- Sample scheduling, and tracking;
- Sample processing and quality control; and
- Sample reporting and data storage.

All LIMS users must be authorized by the LIMS Administrator and permitted specified privileges. The following privilege levels are defined:

- Data Entry Privilege – The individual may see and modify only data within the LIMS that he or she has personally entered.
- Reporting Privilege – Without additional privileges.
- Data Administration Privilege – Data Administrators for the database are allowed to change data as a result of QA screening and related reasons. Data Administrators are responsible for performing the following tasks on a regular basis:
 - Merging/correcting the duplicate data entry files;
 - Running verification/validation routines, correcting data as necessary.

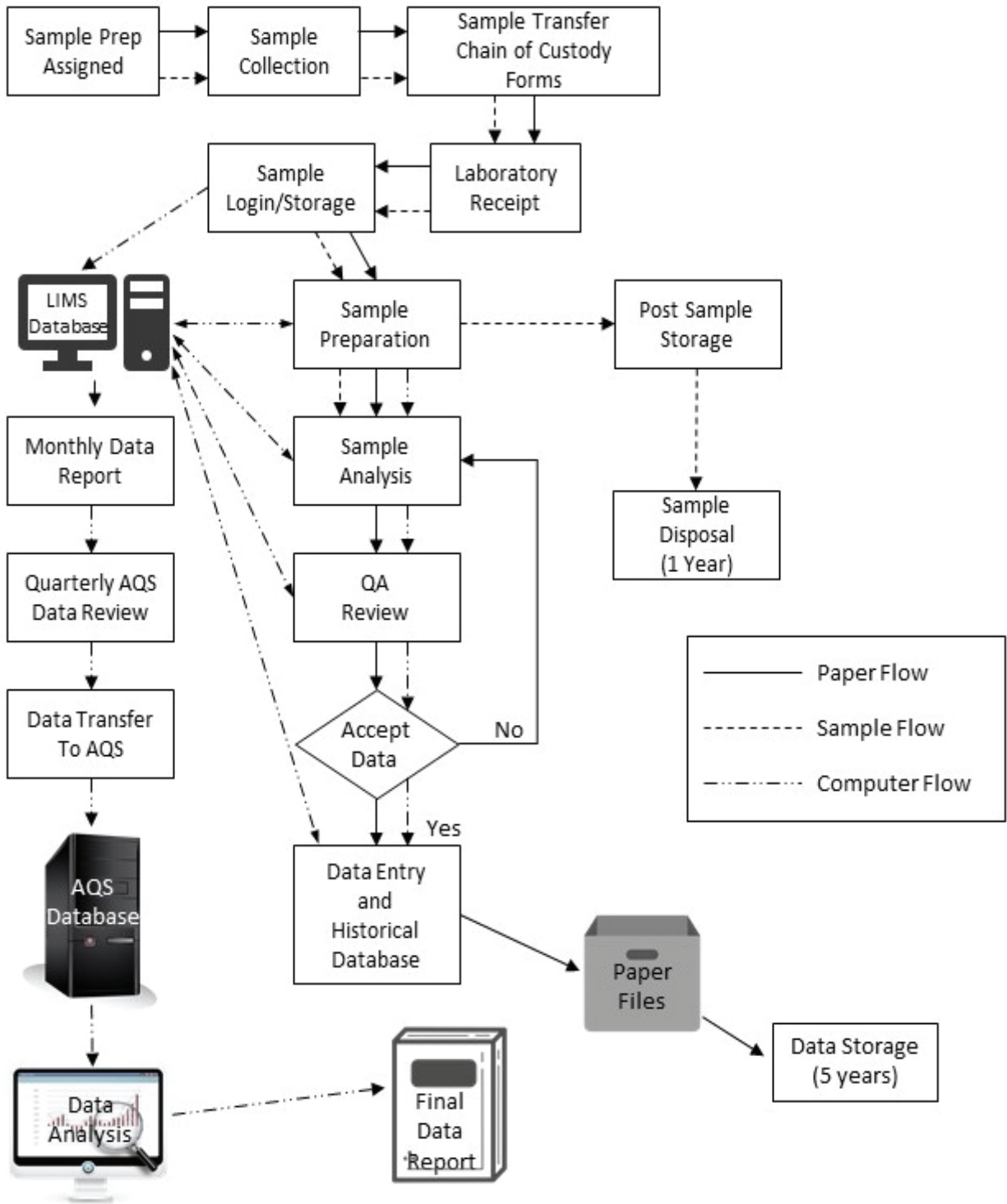

Figure 15-1. Data Management and Sample Flow Diagram

15.2 Data Validation

Data validation is a combination of checking that data processing operations have been carried out correctly and of monitoring the quality of the field operations. Data validation is confirmed by examination of objective evidence that the requirements for a specific intended use are fulfilled as presented in Section 4. This data validation is performed prior to the annual final report. The data reported monthly are considered preliminary until the data is validated, entered into the AQS database, and reported in the annual final report. Data validation is discussed in more detail in Section 18.5.

15.3 Data Reduction and Transformation

Data generated on an instrument is reduced by the analyst via instrument chromatographic software. Any manual integration to chromatographic data follows SOP ERG-MOR-097, the *SOP for Manual Integration of Chromatographic Peaks*. Specific equations used by the instrument chromatographic software to calculate concentration are documented in the individual analytical SOPs found in Appendix C. The equations for transforming raw data are set up to automatically calculate to final concentrations in the LIMS system. The initial and final reporting units for SNMOC are ppbC. All other analyses are reported in units different from their raw data. The initial units for the Carbonyl Compounds analysis are microgram per milliliter ($\mu\text{g}/\text{mL}$), while the final reporting units are in either ppbV or microgram per cubic meter ($\mu\text{g}/\text{m}^3$), per site request, however the NATTS sites are to be reported in $\mu\text{g}/\text{m}^3$ per the NATTS TAD⁽¹⁸⁾. The initial units for VOC are ppbV and the LIMS data reports are in ppbV and $\mu\text{g}/\text{m}^3$. The PAH initial units are $\text{ng}/\mu\text{L}$ with final reporting units of nanogram per cubic meter (ng/m^3). The initial units for metals are ng/L with final reporting units of ng/m^3 . The initial units for the hexavalent chromium analysis are ng/mL with final reporting units of ng/m^3 . The associated MDLs are reported in final reporting units with the final concentrations. MDLs are adjusted for dilution and actual prep volumes, and sample collection volume where applicable, before reporting.

The electronic data file is uploaded onto a network server (which is backed-up daily) and into the LIMS. Once the data is in LIMS, the Task Leader reviews it following the checklists presented in the SOPs using instrument software and the method-specific control limits set up in LIMS. Ten percent of all data is reviewed by the QA Coordinator or designee following the checklist and method specific acceptance criteria in the summary quality control procedure tables outlined in Section 11. After data has successfully completed both reviews and the checklists have been signed, it is available for reporting by the Program Manager.

The *SOP for Project Peer Review* uses manual calculations and visual verification to review all data reported to EPA and State/Local/Tribal agencies following guidelines outlined in SOP ERG-MOR-057 (see Appendix C). *SOP for Developing, Documenting, and Evaluating the Accuracy of Spreadsheet Data*, presented in SOP ERG-MOR-017 (see Appendix C), is consulted in special cases where the calculations are performed via spreadsheets instead of the LIMS system.

Reporting formats are designed to fulfill the program requirements and to provide comprehensive, conventional tables of data. The LIMS data reporting format includes any required data qualifiers, footnotes, detection limits for each analyte, and appropriate units for all measurements. The LIMS can produce Adobe and Excel data reports, which is standard for this program. Each report is reviewed by the Program Manager or designee before it is sent to the client.

15.4 Data Transmittal

Data transmittal occurs when data are transferred from one person or location to another or when data are copied from one form to another. Some examples of data transmittal are copying raw data from a notebook onto a data entry form for keying into a computer file and electronic transfer of data over a computer network. Each individual SOP listed in Appendix C discusses the procedures for determining the calculations of concentrations as well as data entry.

ERG will report all ambient air quality data and information specified by the AQS User's Guide and other documents located at the website <http://www.epa.gov/ttn/airs/airsaqs/manuals/> coded in the AQS format. Such air quality data and information will be fully screened and validated and will be submitted directly to the AQS database via electronic transmission, in the format of the AQS, and in accordance with the annual schedule. The *SOP for the Preparation of Monitoring Data for AQS Upload* is presented in Appendix C (SOP ERG-MOR-098).

15.5 Data Summary

ERG is implementing the data summary and analysis program in the form of a final annual report. The following specific summary statistics will be tracked and reported for the network:

- Single sampler bias or accuracy (based on laboratory audits if available);
- Analytical precision (based on analytical replicates);
- Sampler precision (based on collocated data);
- Network-wide bias and precision; and
- Data completeness.

Equations used for these reports are given in Table 15-1.

Table 15-1. Report Equations

Criterion	Equation
Coefficient of Variation (CV)- p and r are concentrations from the primary and duplicate samplers, respectively. This equation is also used for collocated samples and replicate analysis.	$CV = 100 \times \sqrt{\frac{\sum_{i=1}^n \left[\frac{(p-r)}{0.5 \times (p+r)} \right]^2}{2n}}$
Percent Completeness	<p data-bbox="938 552 1333 615">Completeness $\frac{N_{\text{valid}}}{N_{\text{theoretical}}} * 100$</p> <p data-bbox="846 657 1425 739">Where, N_{valid} is the number of valid samples analyzed in the sampling year and $N_{\text{theoretical}}$ is the number of valid samples that should be taken within that same sampling year</p>

15.6 Data Tracking

The ERG LIMS database contains the necessary input functions and reports appropriate to track and account for the status of specific samples and their data during processing operations. The following input locations are used to track sample and sample data status:

- Sample Control
 - Sample collection information (by Work Order);
 - Sample receipt/custody information;
 - Unique sample number (LIMS ID);
 - Storage location;
 - Required analyses;

- Laboratory
 - Batch/bench assignment;
 - Sequence assignment (if needed);
 - Data entry/review;
 - Query/update analysis status;
 - Standards/calibration information.

15.7 Data Storage and Retrieval

Data archival policies for hardcopy records are shown in Table 15-2.

All data are stored on the ERG LIMS server. This system has the following specifications:

- Operating System: Windows 2008 Server
- Memory: 6G RAM
- Hard Drives: Three drives of 450G each configured as RAID 5;
- Network card: Gigabit card (10/100/1000)
- Tape Drives for Backup: Two tape drives are daisy chained (HP StorageWorks, 1/8 G2 Tape Autoloader). Symantec Backup Exec Software ver. 12.5
- Security: Network login password protection on all workstations; Additional password protection applied by application software.

Security of the data in the database is ensured by the following controls:

- Password protection on the data base that defines three levels of access to the data;
- Logging of all incoming communication sessions, including the originating telephone number, the user's ID, and connect times; and
- Storage of media, including backup tapes, in an alternate location that is at a locked, restricted access area.

Table 15-2. Data Archive Policies

Data Type	Medium	Location	Retention Time	Final Disposition
Laboratory notebooks	Hardcopy	Laboratory	5 years after close of contract	N/A
LIMS Database	Electronic (on-line)	Laboratory	Backup media after 5 years	Backup tapes retained indefinitely

ASSESSMENT/OVERSIGHT

SECTION 16

ASSESSMENTS AND RESPONSE ACTIONS

An assessment is defined as an evaluation process used to measure the performance or effectiveness of the quality system or the establishment of the monitoring network and sites and various measurement phases of the data operation.

The results of QA assessments indicate whether the control efforts are adequate or need to be improved. Documentation of all QA and QC efforts implemented during the data collection, analysis, and reporting phases are important to data users, who can then consider the impact of these control efforts on the data quality. Both qualitative and quantitative assessments of the effectiveness of these control efforts will identify those areas most likely to impact the data quality. ERG will perform the following assessments to ensure the adequate performance of the quality system.

16.1 Assessment Activities and Project Planning

16.1.1 External Technical Systems and Data Quality Audits

A TSA is a thorough and systematic on-site qualitative audit, where facilities, equipment, personnel, training, procedures, subcontractor systems, and record keeping are examined for conformance to the QAPP. The TSAs will be performed by EPA or its designee at the ERG Laboratory. The TSAs for the contract are conducted approximately every 3 years. The EPA QA Office will implement the TSA either as a team or as an individual auditor. ERG will participate in any data quality audits by EPA or designee at the discretion of the EPA QA Coordinator.

The EPA audit team will prepare a brief written summary of findings for the Program Manager and Program QA Coordinator. Problems with specific areas will be discussed and an attempt made to rank them in order of their potential impact on data quality. ERG will work with

EPA to solve required corrective actions. As part of corrective action and follow-up, an audit finding response letter will be generated by the Program Manager and Program QA Coordinator. The audit finding response letter will address what actions are being implemented to correct the finding(s) of the TSA. This summary from EPA and the following response from ERG are filed in the QA/QC file in Room 102. The findings and the follow-up corrective actions are discussed in the annual QA Management Systems Review.

As part of ongoing National Environmental Laboratory Accreditation Conference (NELAC) certification, TSAs are performed at ERG by Florida Department of Health or designee every two years. A summary of findings is sent to ERG, specifically the QA Coordinator. The QA Coordinator sends its response of corrective actions which is either accepted or denied by Florida Department of Health. This documentation is stored in the QA/QC file in Room 102. The findings and the follow-up corrective actions are discussed in the annual QA Management Systems Review.

16.1.2 Internal Technical Systems Audits

An internal TSA is performed examining facilities, equipment, personnel, training, procedures, and record keeping for conformance to the individual SOPs and this QAPP. The TSAs will be performed by the Program QA Coordinator and will be conducted at least once per year. The checklists for the internal TSAs are based on the NATTS TSA or National Environmental Laboratory Accreditation Program (NELAP) checklists with additional areas addressing the individual SOPs and this QAPP. The content of the checklists vary episode to episode to ensure comprehensive in-depth coverage of procedures over time. Such elements will be included in the checklists:

- Criteria listed in Section 11 of this QAPP
- SOP specifications
- Method specifications
- Supporting equipment specifications
- Other laboratory wide QA systems in place (ex. Satellite SOP notebooks)

The Program QA Coordinator will report internal audit findings to the Program Manager within 30 days of completion of the internal audit in the form of a report. The EPA Delivery Order Manager will be informed if issues from the internal audit impact the quality of this program. The report is filed in the QA/QC file in Room 102. All corrective actions are addressed and implemented as soon as they are determined. The findings and the follow-up corrective actions are discussed in the annual QA Management Systems Review to assess effectiveness of the corrective actions.

16.1.3 Proficiency Testing

The PT is an assessment tool for the laboratory operations. ‘Blind’ samples are sent to the laboratory, where they follow the normal handling routines that any other sample follows. The results are sent to the Program Manager and Program QA Coordinator for final review and reporting to the auditing agency. The auditing agency prepares a PT report and sends a copy of the results to the Program Manager, Program QA Coordinator, and the EPA QA Office(s). Any results outside the acceptance criteria are noted in the PT report. Repeated analyte failures are investigated to determine the root cause and documented on a CAR. The PT reports are filed in the QA/QC file in Room 102. The performance on these audits is discussed in the annual QA Management Systems Review.

Currently, there is one audit program supported by this contract. This is provided through the NATTS program for carbonyl, metals, VOC, and PAH audits. These audits are provided to ERG from EPA (or an EPA contractor) throughout the year. The acceptable limits are provided on the annual reports presented to the participating States and EPA.

ERG participates in round robin studies, such as Regional EPA round robin studies, when available for VOC, metals, carbonyls, and SNMOC. In these studies, each participating laboratory result is compared against the calculated average. Reports from these studies are kept in the QA/QC file in Room 102. The performance on these studies is discussed in the annual QA Management Systems Review.

16.1.4 Data Assessment for Final Report

A data quality assessment is the statistical analysis of environmental data to determine whether the quality of data is of adequate quality, based on the MQOs. The data assessment in the final report is presented to EPA and State agencies and includes the following:

- Review of the MQOs of the program, which includes completeness, precision and accuracy.
- Present the results of the data quality assessment using summary statistics, plots and graphs while looking for and discussing any patterns, relationships, or anomalies.
- Qualify the data that does not meet the MQO for completeness for each monitoring site and for site-specific summary statistics.

16.2 **Documentation of Assessments**

16.2.1 TSA, Data Quality Audit, and PT Documentation

All reports from EPA or designated contractors regarding ERG's performance on TSAs, Data Quality Audits, and PTs are filed in the QA/QC file in Room 102. PT reports are dispersed and discussed with contributing staff.

Reports from internal TSAs are prepared and discussed with the contributing staff and Program Manager and filed in the QA/QC file in Room 102.

16.2.2 Internal Data Review Documentation

Internal data review is performed on 100 percent of the data by the Task Leader and 10 percent of the data by the Program QA Coordinator or designee against the criteria in the individual SOPs and this QAPP prior to being reported each month. The assessment is documented on the data review checklist, which is returned to the Task Leader for minor

correction action and inclusion in the data package. The checklists used for analyses are shown in their respective SOPs (Appendix C) as follows:

- **VOC** – ERG-MOR-005, *SOP for the Concurrent GC/FID/MS Analysis of Canister Air Toxic Samples using EPA Compendium Method TO-15 and EPA Ozone Precursor Method.*
- **Carbonyl** – ERG-MOR-024, *SOP for Preparing, Extracting, and Analyzing DNPH Carbonyl Cartridges by Method TO-11A.*
- **SVOC/PAH** – ERG-MOR-049, *SOP for Analysis of Semivolatile Organic Compounds (Polynuclear Aromatic Hydrocarbons) Using EPA Compendium Method TO-13A & ASTM D6209.*
- **Metals** – ERG-MOR-095, *SOP for the Analysis of High Volume Quartz, Glass Fiber Filters, and 47 mm Filters for Metals by ICP-MS using Method IO 3.5 and FEM Method EQL-0512-201 and FEM Method EQL-0512-202.*
- **Hexavalent chromium** – ERG-MOR-063, *SOP for the Preparation and Analysis of Ambient Air for Hexavalent Chromium by Ion Chromatography.*
- **SNMOC** – ERG-MOR-005, *SOP for the Concurrent GC/FID/MS Analysis of Canister Air Toxic Samples using EPA Compendium Method TO-15 and EPA Ozone Precursor Method.*

During the internal data review, major QC problems identified are brought to the attention of the Program Manager and are documented on a CAR. The final project report also addresses QA considerations for the whole project.

16.3 Corrective Action

The Response/Corrective Action Report (CAR) will be filed whenever a problem is found such as an operational problem, or a failure to comply with procedures that affects the quality of the data. A CAR is an important ongoing report to management because it documents primary QA activities and provides valuable records of QA actions. A CAR can be originated by anyone on the project but must be sent to the Program QA Coordinator and Program Manager. Any problem that affects the quality of the overall program will be discussed with EPA.

On the numbered CAR, the description of the problem, the cause of the problem, the corrective action, and the follow-up are documented. The follow-up assists the QA coordinator in determining if the corrective action was successful and if it was handled in a timely manner. The CAR is recorded on a three-part form, the white copy goes into the project file, the yellow copy goes into the QA file (Room 102), and the pink copy goes to the facilitator. A copy of the ERG CAR Form is shown in Figure 16-1.

Each recommendation addresses a specific problem or deficiency and requires a written response from the responsible party. The Program QA Coordinator will verify that the corrective action has been implemented. A summary of the past years' CARs are discussed during the annual QA Management Systems Review.

The following actions are taken by the laboratory QA Coordinator and Program Manager when any aspect of the testing work, or the results of this work, does not conform to the requirements of the quality system or testing methods:

- Identify nonconforming work and take actions such as halting of work or withholding test reports;
- Evaluate of the impact of nonconforming work on quality and operations;
- Take remedial action and make decision about the acceptability of the nonconforming work (resample, use as is with qualification, or unable to use);
- Notify the client, and if necessary, recall the work; and
- Authorize the continuation of work.

ERG and its subcontractors are responsible for implementing the analytical phase of this program and are not responsible for the overall DQOs. Therefore, this QAPP tries to ensure that analytical results are of known and adequate quality to ensure the achievement of the various program DQOs.

CAR Number: 2018-



Corrective Action Report

CAR Initiator: _____ Initiation Date: _____

Area/Procedure Affected: [Click or tap here to enter text.](#)

Is Immediate Stop of Work Required? [Choose an item.](#)

Non-Conformance

Date of Discovery: _____

Description of Non-Conformance: [What happened? How is this a non-conforming event?](#)

[Click or tap here to enter text.](#)

Investigation of Non-Conformance: [How was the non-conformance discovered?](#)

[Click or tap here to enter text.](#)

Impact Assessment: [What is affected by the nonconformance?](#)

[Click or tap here to enter text.](#)

Root Cause Analysis: [What caused the nonconformance?](#)

[Click or tap here to enter text.](#)

Further Analysis: [Could this nonconformance be evident in other areas?](#)

[Click or tap here to enter text.](#)

Corrective Action

Due Date for Remedial Action Completion: _____

Immediate and/or Long-Term Remedial Corrective Actions Taken: _____

Assessment of Corrective Action Effectiveness: _____

[Click or tap here to enter text.](#)

Signatures

	Signature & Date	Comments
QA Officer:	_____	Click or tap here to enter text.
Project Manager:	_____	Click or tap here to enter text.
Initiator:	_____	Click or tap here to enter text.

Follow-up

Reference or attach documentation that demonstrates the return to conformance, or describe below.

[Click or tap here to enter text.](#)

Follow-up Auditor: [Click or tap here to enter text.](#)

Date Completed: _____

Were corrective action procedures effective?

[Click or tap here to enter text.](#)

Figure 16-1. ERG Response/Corrective Action Report Form

SECTION 17

REPORTS TO MANAGEMENT

This section describes the quality-related reports and communications to management necessary to support monitoring network operations and the associated data acquisition, validation, assessment, and reporting. Important benefits of regular monthly reports to EPA provide the opportunity to alert of data quality problems, to propose viable solutions to problems, and to procure necessary additional resources.

Effective communication among all personnel is an integral part of a quality system. Regular, planned quality reporting provides a means for tracking the following:

- Adherence to scheduled delivery of data and reports;
- Documentation of deviations from approved QA and test plans, and the impact of these deviations on data quality; and
- Analysis of the potential uncertainties in decisions based on the data.

17.1 Frequency, Content, and Distribution of Reports

Frequency, content, and distribution of reports for monitoring are shown below.

17.1.1 Monthly and Annual Reports

Analytical data reports prepared by the Program or Deputy Program Manager are sent to EPA, State, Local and Tribal agencies monthly. These reports include the analytical data for each sample collected monthly including sample results, MDLs, sample information (canister ID, sample volume, etc.) and a QA report (could include duplicates, MB, CCB, CCV, MS/MSD, etc., depending on the analysis). Quarterly QA reports are distributed which include a summary of analyte specific quality control charts (ICV, ICB, CCB, CCV, BLK, BS/BSD, etc.). An annual data report, containing a summary of the monthly reported data and a yearly assessment of the air toxics data, is reported to EPA and State agencies by the Program Manager. This report

documents the statistical analysis and quality assessment for the measurement data and how the objectives for the program were met.

The annual report includes the quality information for each toxic monitoring network in each state. Each report includes:

- Program overview and update;
- Quality objectives for measurement data;
- Data quality assessment;
- Collocated and duplicate sampling estimates for precision and bias; and
- PTs that were performed during the study, if applicable.

17.1.2 Internal Technical System Audit Reports

The Program QA Coordinator or designee performs an internal technical system audit at least once a year for the monitoring network for EPA, State, and NATTS contracts. The findings are listed in reports which are presented to the Program Manager and filed in the QA/QC storage file cabinet located in Room 102. These reports are available to EPA personnel during their TSA. More detail on internal TSAs is provided in Section 16.

DATA VALIDATION AND USABILITY
SECTION 18
DATA REVIEW AND VERIFICATION

Data verification is a two-stage process to determine if the sampling and analytical data collection process is complete, consistent with the DQOs discussed in this QAPP and associated SOPs, and meets the program requirements. First the data is reviewed for completeness, accuracy, and acceptability. Then the data is verified to meet the quality requirements of the program.

18.1 Data Review Design

Information used to verify air toxics data, includes:

- Sample COCs, holding times, preservation methods.
- Multi-point calibrations – the multipoint calibrations are used to establish proper initial calibration and can be used to show changes in instrument response.
- Standards – certifications, identification, expiration dates.
- Instrument logs – all activities and samples analyzed are entered into the LIMS logs (batches, sequences, etc.) to track the samples throughout the measurements procedures.
- Supporting equipment – identification, certifications, calibration, if needed.
- Blank, CCVs, replicate and spike results – these QC indicators can be used to ascertain whether sample handling or analysis is causing bias in the data set.
- Review Checklists – these record data quality review performed on all data by Task Leader and on 10 percent of the data by the QA Coordinator or designee. The checklists used to review data is presented in the SOPs.
- Summary Reports – monthly summary data reports present the preliminary data to EPA and respective State/Local/Tribal representatives including data qualifiers.

The reliability and acceptability of environmental analytical information depends on the rigorous completion of all the requirements outlined in the QA/QC protocol. During data analysis and validation, data are filtered and accepted or rejected based on the set of QC criteria listed in the individual SOPs included in Appendix C.

The data are critically reviewed to locate and isolate spurious values. A spurious value, when located, is not immediately rejected. All questionable data, whether rejected or not, are maintained along with rejection criteria and any possible explanation. Such a detailed approach can be time-consuming but can also be helpful in identifying sources of error and, in the long run, save time by reducing the number of outliers.

18.2 Data Verification

Data verification by examination confirms that specified method requirements have been fulfilled. The specific requirements are QC checks, acceptable data entry limits, etc. as presented in Section 11. The analytical procedures performed during the monitoring program will be checked against those described in the QAPP and the SOPs for the UATMP, PAMS, and NMOC support included in Appendix C. Deviations from the QAPP will be classified as acceptable or unacceptable, and critical or noncritical. During review and assessment, qualifiers will be applied to the data as needed; data found to have critical flaws (such as low spike for surrogate recoveries, contaminated blanks, etc.) will be invalidated and a CAR filled out and implemented, if needed. All data management guidelines followed for this contract are presented in Section 15.

18.3 Data Review

The COC forms are checked to ensure accurate transcription. The data are scrutinized daily to eliminate the collection of invalid data. The analyst records any unusual circumstances during analysis (e.g., power loss or fluctuations, temporary leaks or adjustments, operator error) on the LIMS bench sheet and notifies the analytical Task Leader.

QC samples and procedures performed during the monitoring program will be checked against those described in Section 11 of the QAPP. If QC is found unacceptable, corrective actions are implemented (as described in the same section). Prior to reporting, 100 percent of the data is reviewed by the Task Leader(s). To verify accuracy, at least 10 percent of the database is checked by the QA Coordinator or designated reviewer. Items checked can include original data sheets, checks of all calculations (from calibration to sample analysis), and data transfers. As the data are checked, corrections are made to the database as errors or omissions are encountered. If major errors are found, a greater percent of the data is checked to verify data quality. The Program Manager reviews all data before it is reported to EPA or the State/Local/Tribal agencies.

18.4 Data Reduction and Reporting

Monthly site-specific data summaries for the NMP are distributed to the participating EPA technical staff, administrators, and to the administrators of the State/Local/Tribal agencies involved in the study. NATTS, CSATAM, and UATMP data consists of any toxics including VOC, SNMOC, carbonyl, or other HAPs (metals, semivolatiles, etc.) requested by the program participants. Each report is prepared after 45 days from the end of the sampling month. Cumulative listings are periodically generated upon request. This timely turnaround of data assists in planning, preliminary modeling, and program development for the participating State/Local/Tribal agencies. Any changes made in the preliminary data because of subsequent data validation processes performed by EPA and/or State/Local/Tribal agencies are noted in the cumulative project data summaries for each specific sampling site. The data summaries include:

- Site code;
- Sample identifications;
- Sample dates;
- Target compound list;
- Concentrations (ppbv, ppbC, ng/m³ and/or µg/m³); and

- Method detection limits.

Preliminary monthly data summaries are emailed to the program participants. These data summaries are considered preliminary until the data is validated and entered into the AQS database, as detailed in Section 18.6.

The Program Manager reviews all data before they are reported to EPA and/or the State/Local/Tribal agencies. ERG prepares a final report containing all aspects of the individual programs including data summaries, QA, QC, and data analysis results for EPA, and distributes site-specific summaries of the final data to designated personnel.

18.5 Data Validation

Data validation is confirmed by examination of objective evidence that the requirements for a specific intended use are fulfilled as presented in Section 4. Intended use deals with data of acceptable quality to permit making decisions at the correct level of confidence. This data validation is performed prior to the annual final report. The data reported monthly are considered preliminary until the data is validated, entered into the AQS database, and reported in the annual final report.

The Precision from analysis of replicate samples in CV is determined by site, by compound, and as an average for the method. These precisions are based on analytical analyses only. Precision from the analysis and collection of duplicate/collocate samples in CV is determined by site, by compound, and as an average for the method. These precisions are based on analytical precision and sampling precision. The method average precision also includes collocated samples which can increase precision results. This measure the complete data set is compared against the data quality objective for the NATTS program, even though the other programs are not as stringent. This is accomplished prior to the preparation of the annual final report.

Representativeness can be assessed with site location information and is based on potential sources and select weather station information. This is accomplished while preparing the annual final report. Comparability is based on method measure of the level of confidence with which one data set can be compared to another. Ongoing data review and adherence to the data quality objectives keeps the data quality consistent and therefore comparable over the project. This is an ongoing data quality review followed by a data assessment prior to the preparation of the annual final report.

Completeness is measured by the amount of valid sample data obtained compared to what was expected. This is determined by counting the number of valid samples based on the sampling schedule for a that site. Eighty-five percent is considered complete for all the programs. This is an ongoing assessment used to facilitate make-up sampling in the same quarter when possible.

To ensure that the data is reliable in the ranges of concern, the minimum detection limit targets are those specified for the NATTS program, even though the other programs are less stringent. This is an ongoing assessment since detection limits are determined annually.

18.6 Air Quality System

ERG submits data collected for the NMOC, UATMP, NATTS, CSATAM, PAMS, and other air toxics programs to the AQS database.

Prior to ERG's submittal of data to AQS, the State/Local/Tribal agency submits, at a minimum, Basic Site Information transactions (Type AA) for each sampling site, and Site Street Information (Type AB) and Site Open Path Information (Type AC), if necessary. ERG then submits monitor transactions (Types MA through MN, as applicable) to prepare the AQS database for data upload. Data that are uploaded into AQS include Raw Data transactions (Type RD), QA transactions (Type Duplicate and Replicate, and Pb Analysis Audit) and Blank transactions (Type RB). ERG follows the NATTS TAD⁽¹⁸⁾ to code data for the AQS database.

The submittal process involves the following steps:

- The raw data are formatted into pipe-delimited (|) coding that is accepted by AQS. Raw data, data generated by single sample episodes, by the primary sample (D1) of a duplicate episode, or by collocates (C1 and C2), are submitted using RD transactions. Precision data, data generated by Duplicate and Replicate samples (R1, D2, and/or R2), are submitted using QA transactions, specifically Duplicate and Replicate transactions. Accuracy data, generated for lead-FEM audit results, are also submitted using QA transactions.
- The RD QA (specifically duplicate, replicate and Pb Analysis Audit), and RB coding is generated and reviewed following guidelines specified in the *SOP for the Preparation of Monitoring Data for AQS Upload (ERG-MOR-098)* to ensure that the proper monitor ID (including state, county, site, parameter, and Parameter Occurrence Code (POC) codes), sampling interval, units, method, sample date, start time, and sample values are correct. The transactions are stored as text files for upload into the AQS database.
- Transaction files are primarily loaded under the Monitoring and Quality Assurance screening group.
- Transactions are edited to correct any errors found by AQS and then resubmitted. This step is repeated until the transactions are free of errors.
- AQS performs a statistical check on the data submitted to validate the data and determines if there are any outliers based on past data.
- Raw data (RD) transactions are then posted into the AQS database.

18.6.1 AQS Flagging and Reporting

Air toxics data submittals may be submitted with flags to indicate additional information related to the sample. There are two qualifier flag types that may be applied: Null codes and Qualifier codes.

- **Null Code** — assigned when a scheduled sample is not usable (e.g., canister leaked, canister damaged in shipment, etc.).
- **Qualifier Code** — used to note a procedural or quality assurance issue that could possibly affect the concentration of the value or the uncertainty of the result. These flags can also be applied to indicate atypical field conditions (e.g., nearby fires, construction in the area).

Qualifier Codes can be used in combination, with up to 10 possible codes applied. If a Null code is used, no other flag should be used since no results are reported. Table 18-1 presents the Qualifier codes and Table 18-2 presents the Null codes available to AQS users. These flags are applicable to the various steps of sample collection and analysis such as field operations, chain of custody, and laboratory operations.

Blank issue flags are qualifier flags used if reported blank values are above the limits set by the method SOPs or QAPP. If high blank values are associated with samples, the sample values are reported but appropriately flagged as described in the NATTS TAD⁽¹⁸⁾. Samples will not be invalidated due to high blank values. Blank issue flags are included in Table 18-1.

**Table 18-1
Qualifier Codes**

Qualifier Code	Qualifier Description
1	Deviation from a CFR/Critical Criteria Requirement
1V	Data reviewed and validated
2	Operational Deviation
3	Field Issue
4	Lab Issue
5	Outlier
6	QAPP Issue
7	Below Lowest Calibration Level
9	Negative value detected - zero reported
CB	Values have been Blank Corrected
CC	Clean Canister Residue
CL	Surrogate Recoveries Outside Control Limits
DI	Sample was diluted for analysis
DN	DNPH peak less than NATTS TAD requirement, reported value should be considered an estimate
EH	Estimated; Exceeds Upper Range
FB	Field Blank Value Above Acceptable Limit
FX	Filter Integrity Issue
HT	Sample pick-up hold time exceeded
IA	African Dust
IB	Asian Dust
IC	Chemical Spills & Industrial Accidents
ID	Cleanup After a Major Disaster
IE	Demolition
IF	Fire – Canadian
IG	Fire - Mexico/Central America

**Table 18-1
 Qualifier Codes, Continued**

Qualifier Code	Qualifier Description
IH	Fireworks
II	High Pollen Count
IJ	High Winds
IK	Infrequent Large Gatherings
IL	Other
IM	Prescribed Fire
IN	Seismic Activity
IO	Stratospheric Ozone Intrusion
IP	Structural Fire
IQ	Terrorist Act
IR	Unique Traffic Disruption
IS	Volcanic Eruptions
IT	Wildfire-U. S.
J	Construction
LB	Lab blank value above acceptable limit
LJ	Identification of Analyte Is Acceptable; Reported Value Is an Estimate
LK	Analyte Identified; Reported Value May Be Biased High
LL	Analyte Identified; Reported Value May Be Biased Low
MD	Value less than MDL
MS	Value reported is ½ MDL substituted
MX	Matrix Effect
ND	No Value Detected, Zero Reported
NS	Influenced by nearby source
QP	Pressure Sensor Questionable
QT	Temperature Sensor Questionable
QX	Analyte does not meet QC criteria
SQ	Values Between SQL and MDL
SS	Value substituted from secondary monitor
SX	Does Not Meet Siting Criteria
TB	Trip Blank Value Above Acceptable Limit
TT	Transport Temperature is Out of Specs
V	Validated Value
VB	Value below normal; no reason to invalidate
W	Flow Rate Average out of Spec.
X	Filter Temperature Difference out of Spec.
Y	Elapsed Sample Time out of Spec.

**Table 18-2
 Null Codes**

Null Code	Qualifier Description
AA	Sample Pressure out of Limits
AB	Technician Unavailable
AC	Construction/Repairs in Area
AD	Shelter Storm Damage
AE	Shelter Temperature Outside Limits
AF	Scheduled but not Collected
AG	Sample Time out of Limits
AH	Sample Flow Rate out of Limits
AI	Insufficient Data (cannot calculate)
AJ	Filter Damage
AK	Filter Leak
AL	Voided by Operator
AM	Miscellaneous Void
AN	Machine Malfunction
AO	Bad Weather
AP	Vandalism
AQ	Collection Error
AR	Lab Error
AS	Poor Quality Assurance Results
AT	Calibration
AU	Monitoring Waived
AV	Power Failure
AW	Wildlife Damage
AX	Precision Check
AY	Q C Control Points (zero/span)
AZ	Q C Audit
BA	Maintenance/Routine Repairs
BB	Unable to Reach Site
BC	Multi-point Calibration
BD	Auto Calibration
BE	Building/Site Repair
BF	Precision/Zero/Span
BG	Missing ozone data not likely to exceed level of standard
BH	Interference/co-elution/misidentification
BI	Lost or damaged in transit
BJ	Operator Error
BK	Site computer/data logger down
BL	QA Audit
BM	Accuracy check
BN	Sample Value Exceeds Media Limit
BR	Sample Value Below Acceptable Range
CS	Laboratory Calibration Standard
DA	Aberrant Data (Corrupt Files, Aberrant Chromatography, Spikes, Shifts)

**Table 18-2
 Null Codes (Continued)**

Null Code	Qualifier Description
DL	Detection Limit Analyses
EC	Exceeds Critical Criteria
FI	Filter Inspection Flag
MB	Method Blank (Analytical)
MC	Module End Cap Missing
QV	Quality Control Multi-point Verification
SA	Storm Approaching
SC	Sampler Contamination
ST	Calibration Verification Standard
SV	Sample Volume out of Limits
TC	Component Check & Retention Time Standard
TS	Holding Time or Transport Temperature Is Out Of Specs.
XX	Experimental Data

ERG submits data to AQS using qualifier flags to show where the data are with respect to the detection level. A variety of terms and acronyms are used for defining the lowest level that can be detected for each analytical method. These terms and applications are derived from EPA's TAD for the NATTS program and are presented below:

- **Quantitation Limits (QL)** — the lowest level at which the entire analytical system must provide a recognizable signal and acceptable calibration point for the analyte.
- **Detection Limits (DL)** — the minimum concentration of an analyte that can be measured above instrument background.
- **MDL** — the minimum concentration of a substance that can be measured and reported with 99 percent confidence that the analyte concentration is greater than zero and is determined from analysis of a sample in each matrix containing the analyte (Part 136, App. B).
- **SQL** — the lowest concentration of an analyte reliably measured within specified limits of precision and accuracy during routine laboratory operating conditions. Normally, the SQL is determined as a multiplier of the method detection limit (e.g., 3.18 times) and is considered the lowest concentration that can be accurately measured, as opposed to just detected.

The qualifier flags associated with quantitation and detection limits are also included in Table 18-1, while Table 18-3 summarizes how they are applied to the data.

**Table 18-3
 Summary of Quantitation and Detection Limit Flags and Applications**

If Concentration is:	Value to Report	Flag Applied
> SQL	Value	None
≥ MDL and ≤ SQL	Value	SQ
< MDL	Value	MD
Not Detected	0	ND

SECTION 19

DATA VALIDATION, VERIFICATION METHODS

Many of the processes for verifying and validating the measurement phases of the data collection operation have previously been discussed in Section 18. If these processes are followed, and the sites are representative of the boundary conditions for which they were selected, one would expect to achieve the DQOs. However, exceptional field events may occur, and field and laboratory activities may negatively affect the integrity of samples. In addition, it is expected that some of the QC checks will fail to meet the acceptance criteria. This section will outline how ERG will take the data to a higher level of quality analysis by performing software tests, plotting, and other methods of analysis.

19.1 Process for Validating and Verifying Data

19.1.1 Verification of Data

For the analytical data, the entries are reviewed to reduce the possibility of entry and transcription errors. Once the data are transferred to the ERG LIMS database, the data will be reviewed for routine data outliers and data outside acceptance criteria. These data will be flagged appropriately. Prior to reporting, 100 percent of the data is reviewed by the TL(s) and 10 percent of the database is checked by the QA Coordinator or designated reviewer. The PM also reviews the data prior to the preliminary report. After a preliminary reporting batch is completed, a review of 10 percent of the data will be conducted for completeness and manual and electronic data entry accuracy by the Annual Report/AQS TL.

19.1.2 Validation of Data

Data validation is performed by examination of objective evidence that the requirements for a specific intended use are fulfilled as presented in Section 4. Data is examined for representativeness, completeness, precision, and bias. This data validation, some of it performed

with summary statistical analysis, is performed prior to the annual final report. Data validation is discussed in more detail in Section 18.5.

19.2 Data Analysis

Data analysis refers to the process of interpreting the data that are collected. Although there are a large number of parameters to analyze, many of these parameters present similar characteristics, (i.e., VOC, SVOC, and particulate metals, grouped according to their physical and chemical properties).

ERG will employ software programs, described below, to help analyze the data.

Spreadsheet – Select ERG employees perform analysis on the data sets using Excel[®] spreadsheets (analysts, Task Leaders, and QA reviewers) and Access[®] databases (AQS data entry). Spreadsheets and databases allow the user to input data and statistically analyze, graph linear data. This type of analysis will allow the user to see if there are any variations in the data sets. In addition, various statistical tests such as tests for linearity, slope, intercept, or correlation coefficient can be generated between two strings of data. Time series plots and control charts can help identify the following trends:

- Large jumps or dips in concentrations;
- Periodicity of peaks within a month or quarter; and
- Expected or unexpected relationships among species.

SECTION 20

RECONCILIATION WITH DATA QUALITY OBJECTIVES

The project management team, QA Coordinator, and sampling and analytical team members are responsible for ensuring that all measurement procedures are followed as specified and that measurements data meet the prescribed acceptance criteria. Prompt action is taken to correct any problem that may arise.

20.1 Conduct Preliminary Data Review

A preliminary data review will be performed as discussed in Sections 16 and 18 to uncover potential limitations to using the data, to reveal outliers, and generally to explore the basic structure of the data. The next step is to calculate basic summary statistics, generate graphical presentations of the data, and review these summary statistics and graphs to determine if the program requirements in Section 4, representativeness, comparability, completeness, precision, bias, and sensitivity, were met. Representativeness can be assessed with site location information and is based on potential sources and select weather station information. Comparability is based on method measure of the level of confidence with which one data set can be compared to another. Completeness is measured by the amount of valid sample data obtained compared to what was expected. Precision is determined from replicate analyses for a given method. Laboratory bias is demonstrated through PT samples and second source standards. Sensitivity is demonstrated through minimum detection limits.

20.2 Draw Conclusions from the Data

If the sampling design and statistical tests conducted during the final reporting process show results that meet acceptance criteria, it can be assumed that the network design and the uncertainty of the data are acceptable. This conclusion can then be reported to EPA and the States/Local/Tribal agencies, who then decide whether to perform risk assessments and analyze the data to determine whether these data can be used to address health effects.

SECTION 21

REFERENCES

1. McAllister, R. A., D-P. Dayton, and D. E. Wagoner. *1985 Nonmethane Organic Compounds Monitoring Assistance for Certain States in EPA Regions I, III, V, VI, and VII*. Radian Corporation, DCN No. 85-203-024-35-01, prepared for Dr. Harold G. Richter, Research Triangle Park, NC: U.S. Environmental Protection Agency, 1986.
2. *Technical Assistance Document for Sampling and Analysis of Ozone Precursors*. U.S. Environmental Protection Agency, National Exposure Research Laboratory, Research Triangle Park, NC. EPA 600-R-98/161. September 1998. Can be found at <https://www3.epa.gov/ttn/amtic/files/ambient/pams/newtad.pdf>.
3. Compendium Method TO-12, Determination of Non-Methane Organic Compounds (NMOC) in Ambient Air Using Cryogenic Pre-Concentration Direct Flame Ionization Detection (PDFID), 1999. Can be found at <https://www3.epa.gov/ttnamti1/files/ambient/airtox/to-12.pdf>.
4. Compendium Method TO-15, Determination of Volatile Organic Compounds (VOCs) In Air Collected In Specially-Prepared Canisters And Analyzed by Gas Chromatography/Mass Spectrometry (GC/MS), 1999. Can be found at <https://www3.epa.gov/ttnamti1/files/ambient/airtox/to-15r.pdf>.
5. Compendium Method TO-11A, Determination of Formaldehyde in Ambient Air Using Adsorbent Cartridge Followed by High Performance Liquid Chromatography (HPLC), 1999. Can be found at <https://www3.epa.gov/ttnamti1/files/ambient/airtox/to-11ar.pdf>.
6. Compendium Method IO-3.5, The Determination of Metals in Ambient Particulate Matter Using Inductively Coupled Argon Plasma/Mass Spectrometry (ICP-MS), 1999. Can be found at <http://www.epa.gov/ttn/amtic/files/ambient/inorganic/mthd-3-5.pdf>.
7. EQL-0512-201, Standard Operating Procedure for Determination of Lead in TSP by Inductively Coupled Plasma Mass Spectrometry (ICP-MS) with Hot Block Dilute Acid and Hydrogen Peroxide Filter Extraction, 2012. Can be found at <https://www3.epa.gov/ttn/amtic/files/ambient/pb/EQL-0512-201.pdf>.
8. EQL-0512-202, Standard Operating Procedure for the Determination of Lead in PM10 by Inductively Coupled Plasma Mass Spectrometry (ICP-MS) with Hot Block Dilute Acid and Hydrogen Peroxide Filter Extraction, 2012. Can be found at <https://www3.epa.gov/ttn/amtic/files/ambient/pb/EQL-0512-202.pdf>.
9. ASTM D7614, Standard Test Method for Determination of Total Suspended Particulate (TSP) Hexavalent Chromium in Ambient Air Analyzed by Ion Chromatography (IC) and Spectrophotometric Measurements, 2012. Can be found at <https://www.astm.org/Standards/D7614.htm>.

10. Compendium Method TO-13A, Determination of Polycyclic Aromatic Hydrocarbons (PAHs) in Ambient Air Using Gas Chromatography/Mass Spectrometry (GC/MS), 1999. Can be found at <https://www3.epa.gov/ttnamti1/files/ambient/airtox/to-13arr.pdf>.
11. SW-846, Method 8270D, Semivolatile Organic Compounds by Gas Chromatography/Mass Spectrometry (GC/MS), 1996. Can be found at <http://www.epa.gov/epawaste/hazard/testmethods/sw846/pdfs/8270d.pdf>.
12. ASTM_D6209 Standard Test Method for Determination of Gaseous and Particulate Polycyclic Aromatic Hydrocarbons in Ambient Air (Collection on Sorbent-Backed Filters with Gas Chromatographic/Mass Spectrometric Analysis). Can be found at <https://www.astm.org/Standards/D6209.htm>.
13. Compendium Method TO-4A, The Determination of Pesticides and Polychlorinated Biphenyls in Ambient Air Using High Volume Polyurethane Foam (PUF) Sampling Followed by Gas Chromatographic/Multi-Detector Detection (GC/MD), 1999. Can be found at <http://www.epa.gov/ttnamti1/files/ambient/airtox/to-4ar2r.pdf>.
14. NIOSH 7903, Acids, Inorganic, 1994. Can be found at <http://www.cdc.gov/niosh/docs/2003-154/pdfs/7903.pdf>.
15. Compendium Method TO-17, The Determination of Volatile Organic Compounds in Ambient Air Using Active Sampling Onto Sorbent Tubes, 1999. Can be found at <https://www3.epa.gov/ttnamti1/files/ambient/airtox/to-17r.pdf>.
16. OSHA Method 42, Diisocyanates (1,6-Mexamethylene Diisocyanate (HDI), Toluene-2,6-Diisocyanate (2,6-TDI), Toluene-2,4-Diisocyanate (2,4-TDI), 1989. Can be found at <http://www.osha.gov/dts/sltc/methods/organic/org042/org042.html>.
17. NIOSH Method 5029, 4,4'-Methylenedianiline, 1994. Can be found at <http://www.cdc.gov/niosh/docs/2003-154/pdfs/5029.pdf>.
18. *Technical Assistance Document for the National Air Toxics Trends Station Program*. U.S. Environmental Protection Agency. Office of Air Quality Planning and Standards, Research Triangle Park, NC, October 2016. Can be found at https://www3.epa.gov/ttnamti1/files/ambient/airtox/NATTS%20TAD%20Revision%203_FINAL%20October%202016.pdf.
19. U.S. Environmental Protection Agency. Code of Federal Regulations. Title 40, Chapter 1, Part 136, Appendix B. Office of the Federal Register, July 1, 1987. Can be found at https://www.ecfr.gov/cgi-bin/text-idx?SID=dfbcc3c558942b0766bc1dba02b71d72&mc=true&node=ap40.25.136_17.b&rgn=div9.
20. U.S. Environmental Protection Agency. Federal Advisory Committee Act (FACA). Can be found at <http://www.epa.gov/waterscience/methods/det/>.

Appendix A

ERG Exemptions from the NATTS TAD, Revision 3 & 4

**2017 Quality Assurance Project Plan, Category 1
UATMP, NATTS, CSATAM, PAMS, and NMOC Support
(Contract No. EP-D-14-030)**

The proposed **ERG EXEMPTIONS FROM THE NATTS TAD, REVISION 3**, listed in Appendix A of the QAPP have been deemed acceptable as noted by the signatures below.

Approved by:

U.S. EPA QA Manager:

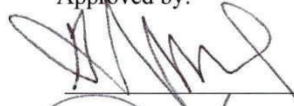

Date: 9/22/17

U.S. EPA Delivery Order Manager:

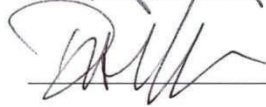

Date: 9/22/17

ERG Program Manager:

Julie L. Swift

Date: 9/22/17

ERG Deputy Program Manager:

Laura Van Emynck

Date: 9/22/17

ERG Program QA Officer:

Diana Tedden

Date: 9/22/17

ERG EXEMPTIONS FROM THE NATTS TAD, REVISION 3 (2017 QAPP, Contract EP-D-14-030)

ERG has provided the documentation to demonstrate that ERG meets the standard, in the form of historical data and/or experimental study results. These exemptions from Revision 3 NATTS TAD were approved and will remain in effect throughout the current contract.

Analyte	TAD Reference Location *	QC Parameter	ERG Exception	EPA Approval/Decision Dave Shelow (EPA Delivery Order Manager) & Greg Noah (QA Manager)
VOCs	4.2.2, pg 66	Both sample results must be qualified when entered into AQS for instances in which collocated or duplicate samples fail precision specifications.	The precision tables do not allow flags. Flags will be uploaded into AQS as permitted.	Approved at June 2017 EPA/ERG meeting (June 23, 2017)
VOCs	4.2.4.1.1.1, pg 74	Canisters with leak rates > 0.1 psi/day must be removed from service and repaired.	ERG evacuates the canisters to ~25" Hg and measured again in seven days. Our acceptance criteria is <1" Hg (QAPP section 11.1). This more accurately mimics the vacuum of the canisters shipped to the field when there is greater potential of major leak affecting the sample concentration.	Approved at June 2017 EPA/ERG meeting (June 23, 2017)
VOCs	4.2.4.2.4, pg 77 Table 4.2-3, pg 93	States on canister per batch cleaned in Section 4.2.4.2.4, but in Table 4.2-3 it states that the canister chosen must represent no more than 10 total canisters.	ERG heated canister cleaning systems are 12-port systems. We propose to continue verifying cleanliness on one canister for each batch of 12. Historical data can be provided if needed.	Approved at June 2017 EPA/ERG meeting (June 23, 2017)
VOCs	4.2.6, pg 80	The recommended tolerance is a pressure change of ≤0.5 psia.	Because of the wide variety of sites, gauges, operators, ERG has created a spreadsheet to track the pressure differences between field and laboratory. If these values differ by historical differences > 3", the samples are invalidated	Approved at June 2017 EPA/ERG meeting (June 23, 2017)

ERG EXEMPTIONS FROM THE NATTS TAD, REVISION 3 (2017 QAPP, Contract EP-D-14-030)

ERG has provided the documentation to demonstrate that ERG meets the standard, in the form of historical data and/or experimental study results. These exemptions from Revision 3 NATTS TAD were approved and will remain in effect throughout the current contract.

Analyte	TAD Reference Location *	QC Parameter	ERG Exception	EPA Approval/Decision Dave Shelow (EPA Delivery Order Manager) & Greg Noah (QA Manager)
VOCs	4.2.8.5.2.2, pg 87 Table 4.2-3, pg 93	Analysis of swept carrier gas through the Preconcentrator to demonstrate the instrument is sufficiently clean to begin analysis (IB).	This is listed as a recommendation in Section 4.2.8.5.2.2 but as a requirement in Table 4.2-3. Because the samples are checked with the analysis of blank samples, ERG will analyze the IB only for trouble shooting purposes.	Approved at June 2017 EPA/ERG meeting (June 23, 2017)
Carbonyls	4.3.2, pg 97	The sample must be kept cold during shipment such that the temperature remains $\leq 4^{\circ}\text{C}$, and the temperature of the shipment must be determined upon receipt at the laboratory.	This requirement will be extremely difficult to achieve during summer months and is not required in Method TO-11A. The vendor does not ship the cartridges to the laboratory in coolers but the samples are shipped overnight with receipt in the laboratory Tuesday through Friday. ERG will conduct a summer study to determine the necessity of this requirement and present it to the EPA in 2017.	Study presented to the EPA on August 25, 2017 validating ERG's exemption. The exemption was approved at this meeting.
Carbonyls	4.3.9.4, pg 115 Table 4.3-4, pg 121	EMSB - For batch sizes of more than 20 field-collected cartridges, n such QC samples of each type must be added to the batch, where n = batch size / 20, and where n is rounded to the next highest integer.	ERG has previously only performed this type of extraction to see if there were problems in a new lot of solvents. Our procedure will perform this extraction once a month, in the first batch of samples prepared each month.	Approved at June 2017 EPA/ERG meeting (June 23, 2017)

ERG EXEMPTIONS FROM THE NATTS TAD, REVISION 3 (2017 QAPP, Contract EP-D-14-030)

ERG has provided the documentation to demonstrate that ERG meets the standard, in the form of historical data and/or experimental study results. These exemptions from Revision 3 NATTS TAD were approved and will remain in effect throughout the current contract.

Analyte	TAD Reference Location *	QC Parameter	ERG Exception	EPA Approval/Decision Dave Shelow (EPA Delivery Order Manager) & Greg Noah (QA Manager)
Carbonyls	4.3.9.5.2, pg 117	For positive identification, the RT of a derivatized carbonyl must be within three standard deviations (3s) or $\pm 2\%$, whichever is smaller, of its mean RT from the ICAL.	ERG's Carbonyl software (Agilent®) allows a $\pm 2.5\%$ window, not $\pm 2.0\%$, but will automatically check if compounds are outside of this window. ERG believes the automatic function is advantageous and will perform LC maintenance checks if the RT fall outside this RT window.	Approved at June 2017 EPA/ERG meeting (June 23, 2017)
Metals	4.4.5, pg 128	Field blank analysis must demonstrate all target elements < MDL.	ERG does not get filters from the same lot that are provided to the field for sampling. Our filters are purchased and we determine the MDLs based on the background in that particular lot. Because of the wide variety of filter lots coming in from the different sites, and until the manufacturers of the filters provide clean enough samples, the majority of the elements could potentially be flagged. ERG proposes to flag only those elements over 5xMDL in order to better accommodate the potential lot differences.	Approved at June 2017 EPA/ERG meeting (June 23, 2017)

ERG EXEMPTIONS FROM THE NATTS TAD, REVISION 3 (2017 QAPP, Contract EP-D-14-030)

ERG has provided the documentation to demonstrate that ERG meets the standard, in the form of historical data and/or experimental study results. These exemptions from Revision 3 NATTS TAD were approved and will remain in effect throughout the current contract.

Analyte	TAD Reference Location *	QC Parameter	ERG Exception	EPA Approval/Decision Dave Shelow (EPA Delivery Order Manager) & Greg Noah (QA Manager)
Metals	4.4.10.5, pg 137	RBS- spiked digestion solution only (no filter strip – ensures proper spike recovery without the filter matrix)	ERG will prepare Standard Reference Material samples (required by NAAQS lead) and perform Post Digestion Spike analysis to ensure proper spike recovery without the filter matrix, instead of preparing and analyzing the RBS.	Approved at June 2017 EPA/ERG meeting (June 23, 2017)
Metals	4.4.10.5.2.1, pg 139	Each filter strip must be accordion folded or coiled and placed into separate digestion vessels.	ERG does not use accordion folding for the QFF filters. The digestion procedure is detailed in SOP 084. Historical data for over 10 years show acceptable recoveries using this method. ERG proposes to keep current folding procedures in place.	Approved at June 2017 EPA/ERG meeting (June 23, 2017)
Metals	4.4.11.7.1, pg 142	Replicate analyses of the calibration standards must show %RSD ≤ 10%	ERG's lowest calibration point is at the LOQ concentration. Our standard practice is to have all cal points at %RSD ≤ 10%, but the low cal point at %RSD ≤ 20%. This standard uses the same concentrations as the Limit of Quantitation (LOQ) standard, which are near or less than that of the MDL, therefore an RSD ≤ 20 percent is acceptable.	Added text in QAPP Section 11.3.5, "Replicate analysis of the calibration standards must have an RSD ≤ 10 percent, except for the second calibration standard (CAL2). This standard uses the same concentrations as the Limit of Quantitation (LOQ) standard, which are near or less than that of the MDL, therefore an RSD ≤ 20 percent is acceptable." Approved at June 2017 EPA/ERG meeting (June 23, 2017)

ERG EXEMPTIONS FROM THE NATTS TAD, REVISION 3 (2017 QAPP, Contract EP-D-14-030)

ERG has provided the documentation to demonstrate that ERG meets the standard, in the form of historical data and/or experimental study results. These exemptions from Revision 3 NATTS TAD were approved and will remain in effect throughout the current contract.

Analyte	TAD Reference Location *	QC Parameter	ERG Exception	EPA Approval/Decision Dave Shelow (EPA Delivery Order Manager) & Greg Noah (QA Manager)
Metals	4.4.11.7.3, pg 143 4.4.11.7.6, pg 144 4.4.11.8, pg 145 Table 4.4-3	The ICB is again analyzed following the ICV; all element responses must be less than the laboratory's established MDL _{sp} for MDLs determined via Section 4.1.3.1 or the portion of the MDL represented by s-K for MDLs determined via Section 4.1.3.2. Also for CCB, negative values, BLK1, and RB.	ERG references the MDL for the ICB, CCB, negative values, reagent blanks and method blanks, not the s * K. ERG does not believe there should be 2 different sets of criteria for instrument/batch QC. These are all < MDL.	Approved at June 2017 EPA/ERG meeting (June 23, 2017)
Metals	4.4.11.7.4, pg 143 Table 4.4-3, pg 147	ICSA - All target elements < MDL _{sp} (refer to Section 4.1.3.1) or s-K (refer to Section 4.1.3.2) - may be subtracted for ICS A certificate of analysis	ERG's criteria is for the results to be within ±3 times LOQ from zero or from the stock standard. This allows us to take into account the background in the interference solution when present.	Approved at June 2017 EPA/ERG meeting (June 23, 2017)
Metals	4.4.9.5.1, pg 132 4.4.10.5.1, pg 137 Table 4.4-3, pg 148	LCS - Recovery within 80-120% of nominal for all target elements, Sb recovery 75-125%.	ERG does not currently flag Sb if it is over 80-120%. ERG will monitor Sb with control charts for 6 months or gather existing data to allow us to statistically determine reasonable acceptance criteria.	Historical control charts presented and it was decided to flag QC and sample data starting 11/1/17. Discussed at the September 2017 EPA/ERG meeting (September 22, 2017)
Metals	4.4.10.5.1, pg 137 Table 4.4-3, pg 148	MS/MSD - Recovery within 80-120% of the nominal spiked amount for all target elements, Sb recovery 75-125%.	ERG does not currently flag Sb if it is over 80-120%. ERG will monitor Sb with control charts for 6 months or gather existing data to allow us to statistically determine reasonable acceptance criteria.	Historical control charts presented and it was decided to flag QC and sample data starting 11/1/17. Discussed at the September 2017 EPA/ERG meeting (September 22, 2017)

ERG EXEMPTIONS FROM THE NATTS TAD, REVISION 3 (2017 QAPP, Contract EP-D-14-030)

ERG has provided the documentation to demonstrate that ERG meets the standard, in the form of historical data and/or experimental study results. These exemptions from Revision 3 NATTS TAD were approved and will remain in effect throughout the current contract.

Analyte	TAD Reference Location *	QC Parameter	ERG Exception	EPA Approval/Decision Dave Shelow (EPA Delivery Order Manager) & Greg Noah (QA Manager)
PAH	4.5.3, pg 152 Table 4.5-3	Lot Blank - Regardless of the source of materials or the specific cleaning procedures each agency adopts, the QFF and PUF/XAD-2/PUF present in cartridges must meet the batch blank acceptance criteria of < 10 ng each for all target compounds. One cartridge for each batch of 20 or fewer prepared cartridges	ERG's procedure has been to prepare one filter per preparation shipment day. Background contamination (even when precleaned before preparing cartridges by the laboratory) show targets > 10 ng per target compound. ERG's criteria is to flag only those compounds which have recoveries > 5x MDL. ERG will monitor 6 months of lot blank data to provide to the EPA to justify exemption.	Historical control charts presented and it was decided to allow a new exemption criteria to be less than the MDL starting 11/1/17. Discussed at the September 2017 EPA/ERG meeting (September 22, 2017)
PAH	4.5.3.3, pg 153	Field surrogates are added no sooner than two weeks prior to the scheduled sample collection date.	ERG will be unable to provide sites with an extra sample media on each sampling day (standard practice) if we are not allowed to have cartridges spiked no sooner than two weeks. This practice is not listed in TO-13A or the ASTM 6209. ERG will perform a study or gather existing data to determine how long the spiked surrogates are stable on the cartridges (up to 3 months) and present it to the EPA to justify exemption.	Study presented to the EPA on August 25, 2017 validating ERG's exemption. The exemption was approved at this meeting.

ERG EXEMPTIONS FROM THE NATTS TAD, REVISION 3 (2017 QAPP, Contract EP-D-14-030)

ERG has provided the documentation to demonstrate that ERG meets the standard, in the form of historical data and/or experimental study results. These exemptions from Revision 3 NATTS TAD were approved and will remain in effect throughout the current contract.

Analyte	TAD Reference Location *	QC Parameter	ERG Exception	EPA Approval/Decision Dave Shelow (EPA Delivery Order Manager) & Greg Noah (QA Manager)
PAH	4.5.4.1b, pg 154	Samples which are shipped overnight should be packed with sufficient cold packs or ice to ensure they arrive at the laboratory at $\leq 4^{\circ}\text{C}$.	This requirement will be extremely difficult to achieve during summer months. ERG will conduct a summer study to determine the necessity of this requirement and present it to the EPA in 2017.	Study presented to the EPA on August 25, 2017 validating ERG's exemption. The exemption was approved at this meeting.
PAH	4.5.5.2, pg 160	Tuning the MS. Table 4.5-2	ERG currently uses the version from 8270D Rev5 July 2014 version which is the updated tune table for where the TO-13A method originally lifted their tune criteria. It is our opinion the original table listed (in Table 4.5-2) was created for older machines with less capability. The 2014 revision gives the operator the ability to tune to the heavier masses and get better resolution on the complex compounds. ERG proposes to continue using the 8270D criteria.	Approved at June 2017 EPA/ERG meeting (June 23, 2017)
PAH	4.5.5.3, pg 161	An SB which is not fortified with IS must be analyzed just prior to calibration to ensure the instrument is sufficiently clean to continue analysis. Analysis of the SB must show all target compounds, IS, and surrogate compounds are not detected	Table 4.5-3 states that the SB must be analyzed before each DF1PP tune. Section 4.5.5.3 states before each calibration. ERG will analyze the SB prior to the ICAL which is required in our DQOs not to exceed 6 weeks.	Approved at June 2017 EPA/ERG meeting (June 23, 2017)

ERG EXEMPTIONS FROM THE NATTS TAD, REVISION 3 (2017 QAPP, Contract EP-D-14-030)

ERG has provided the documentation to demonstrate that ERG meets the standard, in the form of historical data and/or experimental study results. These exemptions from Revision 3 NATTS TAD were approved and will remain in effect throughout the current contract.

Analyte	TAD Reference Location *	QC Parameter	ERG Exception	EPA Approval/Decision Dave Shelow (EPA Delivery Order Manager) & Greg Noah (QA Manager)
PAH	4.5.5.3, pg 162	The RRTs of each surrogate or target compound across the ICAL are then averaged to determine the ICAL RRT. All RRTs must be within ± 0.06 RRT units of RRT.	ERG's VOC software (ChemStation) allows different time deltas for lower and upper time limits. For instance, the window for acenaphthylene is RT - 0.175 and RT + 0.25. The largest delta in the database is RT + 0.25, and it's used for several compounds. These windows for each compound are well within those required using the mean RRT. A table presenting RRTs to ERG's current procedure of tracking RT's is presented in Appendix B.	Approved at June 2017 EPA/ERG meeting (June 23, 2017)
All Analytes	VOC Table 7.1, pg 190	The sampling period for all field samples collected should be 1380-1500 minutes (24 \pm 1 hour) starting and ending at midnight.	ERG has reported any sample that was 22-23 hours or 25-26 hours, but flagged them with a "Y" (Elapsed Sample Time out of Spec.). Anything greater than ± 2 hours is invalidated.	Approved at June 2017 EPA/ERG meeting (June 23, 2017)
	Carbonyl, 4.3.8.1.3, pg 110			
	Metals, 4.4.9.4.1 & 4.4.10.4.1, pg 131 & pg 137			
	PAH, 4.5.4.1, pg 154			

ERG EXEMPTIONS FROM THE NATTS TAD, REVISION 4 (2018 QAPP, Contract EP-D-14-030)

ERG has provided the documentation to demonstrate that ERG meets the standard, in the form of historical data and/or experimental study results. These exemptions from Revision 3 NATTS TAD were approved and will remain in effect throughout the current contract.

Analyte	TAD Reference Location *	QC Parameter	ERG Exception	EPA Approval/Decision Dave Shelow (EPA Delivery Order Manager) & Greg Noah (QA Manager)
VOCs	4.2.3.5.1, pg 71	The zero check is performed by simultaneously providing humidified (50 to 70% RH) hydrocarbon- and oxidant-free zero air (must meet the cleanliness criterion of < 0.2 ppbv or < 3x MDL, whichever is lower) or UHP nitrogen to the sampling unit for collection into a canister and to a separate reference canister connected directly to the supplied HCF zero air gas source.	For the compound acetonitrile, ERG will use the previous criteria from TAD, Rev 2 of <0.2 ppbv.	Approved at July 2018 EPA/ERG meeting (July 27, 2018)

Appendix B
2018 Sampling Schedule

2018 6-Day Sampling Calendar

January						
Sun	Mon	Tue	Wed	Thu	Fri	Sat
	1	2	3	4	5	6
7	D	9	10	11	12	13
14	15	16	17	18	19	20
21	22	23	24	25	FB	27
28	29	30	31			

February						
Sun	Mon	Tue	Wed	Thu	Fri	Sat
				1	2	3
4	5	6	M	8	9	10
11	12	13	14	15	16	17
18	19	20	21	22	23	24
FB	26	27	28			

March						
Sun	Mon	Tue	Wed	Thu	Fri	Sat
				1	2	3
4	5	6	7	8	D	10
11	12	13	14	15	16	17
18	19	20	21	22	23	24
25	26	FB	28	29	30	31

April						
Sun	Mon	Tue	Wed	Thu	Fri	Sat
1	2	3	4	5	6	7
M	9	10	11	12	13	14
15	16	17	18	19	20	21
22	23	24	25	FB	27	28
29	30					

May						
Sun	Mon	Tue	Wed	Thu	Fri	Sat
	1	2	3	4	5	
6	7	D	9	10	11	12
13	14	15	16	17	18	19
20	21	22	23	24	25	FB
27	28	29	30	31		

June						
Sun	Mon	Tue	Wed	Thu	Fri	Sat
					1	2
3	4	5	6	M	8	9
10	11	12	13	14	15	16
17	18	19	20	21	22	23
24	FB	26	27	28	29	30

July						
Sun	Mon	Tue	Wed	Thu	Fri	Sat
1	2	3	4	5	6	7
8	9	10	11	12	D	14
15	16	17	18	19	20	21
22	23	24	25	26	27	28
29	30	FB				

August						
Sun	Mon	Tue	Wed	Thu	Fri	Sat
				1	2	3
4	5	6	7	8	9	10
11	M	13	14	15	16	17
18	19	20	21	22	23	24
25	26	27	28	29	FB	31

September						
Sun	Mon	Tue	Wed	Thu	Fri	Sat
						1
2	3	4	5	6	7	8
9	10	D	12	13	14	15
16	17	18	19	20	21	22
23	24	25	26	27	28	FB
30						

October						
Sun	Mon	Tue	Wed	Thu	Fri	Sat
	1	2	3	4	5	6
7	8	9	10	M	12	13
14	15	16	17	18	19	20
21	22	23	24	25	26	27
28	FB	30	31			

November						
Sun	Mon	Tue	Wed	Thu	Fri	Sat
				1	2	3
4	5	6	7	8	9	D
11	12	13	14	15	16	17
18	19	20	21	22	23	24
25	26	27	FB	29	30	

December						
Sun	Mon	Tue	Wed	Thu	Fri	Sat
						1
2	3	4	5	6	7	8
9	M	11	12	13	14	15
16	17	18	19	20	21	22
23	24	25	26	27	FB	29
30	31					

Standard Sample Collection

FB Field Blank Collection

M Makeup Duplicate Collection or normal sample

D Duplicate Sampling Collection

Appendix C

Relevant ERG Standard Operating Procedures

The information contained herein is confidential and proprietary
And may not be used in any manner or form without the express
Written permission of the Program Manager.

Appendix D

Subcontractors

Quality Assurance Project Plan

RTI Laboratories

Will be provided when work is initiated.

The information contained herein is confidential and proprietary
And may not be used in any manner or form without the express
Written permission of the Program Manager.

APPENDIX D. TECHNICAL ASSISTANCE
DOCUMENT FOR THE NATIONAL AIR TOXICS
TRENDS STATIONS PROGRAM, Revision 3

**TECHNICAL ASSISTANCE DOCUMENT
FOR THE
NATIONAL AIR TOXICS TRENDS STATIONS PROGRAM**

Revision 3

Prepared for:
U.S. Environmental Protection Agency
Office of Air Quality Planning and Standards (C304-06)
Research Triangle Park, NC 27711

Prepared by:
Battelle
505 King Avenue
Columbus, OH 43201

October 2016

DISCLAIMER

This document has been reviewed in accordance with U.S. Environmental Protection Agency policy and has been approved for publication. Mention of trade names or commercial products does not constitute endorsement or recommendation for use.

CONTENTS

LIST OF FIGURES	xi
LIST OF TABLES.....	xi
ACRONYMS AND ABBREVIATIONS.....	xiii
1.0: INTRODUCTION	1
1.1 Background	1
1.2 Target Analytes: Analytes of Critical Concern/Risk Drivers.....	1
1.3 Importance of Adherence to Guidelines.....	4
1.4 Overview of TAD Sections	5
1.5 Critical Changes and Updates from Revision 2 of the NATTS TAD	6
1.6 Good Scientific Laboratory Practices.....	7
1.6.1 Data Consistency and Traceability	7
1.7 NATTS as the Model for Air Toxics Monitoring	7
1.8 References	8
2.0: IMPORTANCE OF DATA CONSISTENCY.....	9
2.1 Data Quality Objectives and Relationship to the Quality Assurance Project Plan	9
2.1.1 Representativeness.....	11
2.1.2 Completeness.....	11
2.1.2.1 Make-up Sample Policy	11
2.1.3 Precision.....	12
2.1.4 Bias	13
2.1.4.1 Assessing Laboratory Bias - Proficiency Testing.....	13
2.1.4.2 Assessing Field Bias	14
2.1.5 Sensitivity	14
2.2 NATTS Workplan	15
2.3 Quality System Development.....	15
2.4 Siting Considerations	17
2.4.1 Sampling Instrument Spacing.....	17
2.4.2 Interferences to Sampling Unit Siting	18
2.4.3 Obstructions.....	18
2.4.4 Spacing from Roadways	19
2.4.5 Ongoing Siting Considerations.....	19
2.5 References	20
3.0: QUALITY ASSURANCE AND QUALITY CONTROL.....	21
3.1 NATTS Quality Management Plan	21
3.2 NATTS Main Data Quality Objective, Data Quality Indicators, and Measurement Quality Objectives	21
3.3 Monitoring Organization QAPP Development and Approval	21
3.3.1 Development of the NATTS QAPP.....	22
3.3.1.1 NATTS QAPP – Program DQOs, DQIs, and MQOs.....	22
3.3.1.2 NATTS QAPP – Performance Based Method Criteria.....	22

3.3.1.3	<i>NATTS QAPP – Incorporating Quality System Elements</i>	23
3.3.1.3.1	<i>Standard Operating Procedure Documents</i>	23
3.3.1.3.2	<i>Corrective Action Process</i>	24
3.3.1.3.3	<i>Quality Assurance Unit and Internal Audit Procedures</i>	26
3.3.1.3.4	<i>Calibration of Instruments</i>	27
3.3.1.3.4.1	<i>Calibration Verification (Checks)</i>	31
3.3.1.3.5	<i>Document Control System</i>	31
3.3.1.3.6	<i>Training Requirements and Documentation, and Demonstration of Capability</i>	32
3.3.1.3.6.1	<i>Initial Demonstration of Capability</i>	33
3.3.1.3.6.2	<i>Ongoing Demonstration of Capability</i>	33
3.3.1.3.7	<i>Sample Custody and Storage</i>	34
3.3.1.3.8	<i>Traceability of Reagents and Standard Materials</i>	34
3.3.1.3.9	<i>Labeling</i>	35
3.3.1.3.10	<i>Early Warning Systems – Control Charts</i>	35
3.3.1.3.11	<i>Spreadsheets and Other Data Reduction Algorithms</i>	36
3.3.1.3.12	<i>Software Validation, Testing, Updating, and Upgrading</i>	36
3.3.1.3.12.1	<i>Software Validation</i>	36
3.3.1.3.12.2	<i>Software Testing</i>	37
3.3.1.3.12.3	<i>Software Updating and Upgrading</i>	37
3.3.1.3.13	<i>Review of Records</i>	37
3.3.1.3.14	<i>Data Verification and Validation</i>	38
3.3.1.3.14.1	<i>Data Verification</i>	38
3.3.1.3.14.2	<i>Data Validation</i>	39
3.3.1.3.15	<i>Reporting of Results to AQS</i>	40
3.3.1.3.15.1	<i>Corrections to Data Uploaded to AQS</i>	45
3.3.1.3.16	<i>Records Retention and Archival, and Data Backup</i>	45
3.3.1.3.17	<i>Safety</i>	45
3.3.2	<i>Standard Operating Procedures</i>	45
3.4	<i>References</i>	47
4.0:	<i>COLLECTION AND ANALYSIS METHODS</i>	48
4.1	<i>Method Detection Limits</i>	48
4.1.1	<i>Frequency of Method Detection Limit Determination</i>	51
4.1.2	<i>MDL Measurement Quality Objectives</i>	51
4.1.3	<i>Determining MDLs</i>	52
4.1.3.1	<i>MDLs via 40 CFR Part 136 Appendix B – Method Update Rule</i>	53
4.1.3.2	<i>MDLs via DQ FAC Single Laboratory Procedure v 2.4</i>	59
4.1.4	<i>References</i>	61
4.2	<i>VOCs – Overview of EPA Compendium Method TO-15</i>	62
4.2.1	<i>General Description of Sampling and Analytical Methods</i>	62
4.2.1.1	<i>Sampling Pathway</i>	65
4.2.1.2	<i>Particulate Filtration</i>	65
4.2.2	<i>Precision – Sample Collection and Laboratory Processing</i>	65

4.2.2.1	<i>Sample Collection and Analysis Precision</i>	66
4.2.2.2	<i>Laboratory Analytical Precision</i>	67
4.2.3	<i>Sample Collection Procedures</i>	68
4.2.3.1	<i>Sampling Equipment Specification</i>	68
4.2.3.2	<i>Sample Collection, Setup, and Retrieval</i>	68
4.2.3.2.1	<i>Sample Setup</i>	68
4.2.3.2.2	<i>Subambient Sample Collection</i>	69
4.2.3.2.3	<i>Superambient (Positive) Pressure Sampling</i>	69
4.2.3.2.4	<i>Sample Retrieval</i>	70
4.2.3.3	<i>Sampling Schedule and Duration</i>	70
4.2.3.4	<i>Sampling Train Configuration and Presample Purge</i>	70
4.2.3.5	<i>Sampling Unit Non-Biasing Certification</i>	70
4.2.3.5.1	<i>Zero Check</i>	71
4.2.3.5.2	<i>Known Standard Challenge</i>	72
4.2.4	<i>Canister Hygiene</i>	72
4.2.4.1	<i>Qualification of Canisters</i>	73
4.2.4.1.1	<i>Canister Bias</i>	73
4.2.4.1.1.1	<i>Canister Integrity and Zero Air Check</i>	73
4.2.4.1.1.2	<i>Known Standard Gas Check</i>	74
4.2.4.2	<i>Canister Cleaning</i>	75
4.2.4.2.1	<i>Heated Canister Cleaning</i>	75
4.2.4.2.2	<i>Cycles of Evacuation and Pressurization</i>	76
4.2.4.2.3	<i>Gas Source for Canister Cleaning Pressurization</i>	76
4.2.4.2.4	<i>Verification of Canister Cleanliness</i>	77
4.2.4.3	<i>Canister Maintenance and Preventive Maintenance</i>	78
4.2.4.3.1	<i>Collection of Whole Air Samples into Canisters</i>	78
4.2.4.3.2	<i>Overtightening of Valves</i>	78
4.2.4.3.3	<i>General Canister Handling</i>	78
4.2.5	<i>Method Detection Limits</i>	79
4.2.6	<i>Canister Receipt</i>	79
4.2.7	<i>Dilution of Canisters</i>	80
4.2.8	<i>GC/MS Tuning, Calibration, and Analysis</i>	80
4.2.8.1	<i>Interferences</i>	80
4.2.8.2	<i>Specifications for the Preconcentrator and GC/MS</i>	81
4.2.8.3	<i>Standards and Reagents</i>	82
4.2.8.3.1	<i>Calibration Standards</i>	82
4.2.8.3.2	<i>Secondary Source Calibration Standards</i>	82
4.2.8.3.3	<i>Internal Standards</i>	82
4.2.8.3.4	<i>Diluent Gases</i>	83
4.2.8.3.5	<i>MS Tuning Standard – BFB</i>	83
4.2.8.3.6	<i>Reagent Water for Humidification of Gases</i>	83
4.2.8.4	<i>Preparation of Calibration Standards and Quality Control Samples</i>	84
4.2.8.4.1	<i>Calibration Standards</i>	84
4.2.8.4.2	<i>Second Source Calibration Verification Sample</i>	85
4.2.8.4.3	<i>Method Blank</i>	85

4.2.8.4.4	<i>Laboratory Control Sample</i>	85
4.2.8.5	<i>Analysis via GC/MS</i>	86
4.2.8.5.1	<i>Tuning of the MS</i>	86
4.2.8.5.2	<i>Leak Check and Calibration of the GC/MS</i>	86
4.2.8.5.2.1	<i>Leak Check</i>	86
4.2.8.5.2.2	<i>Initial Calibration of the GC/MS</i>	87
4.2.8.5.2.3	<i>Secondary Source Calibration Verification</i>	88
4.2.8.5.2.4	<i>Continuing Calibration Verification</i>	89
4.2.8.5.2.5	<i>Analysis of Laboratory QC Samples and Field Samples</i>	89
4.2.8.5.3	<i>Compound Identification</i>	89
4.2.8.5.4	<i>Internal Standards Response</i>	91
4.2.9	<i>Data Review and Concentration Calculations</i>	92
4.2.10	<i>Summary of Quality Control Parameters</i>	93
4.2.11	<i>References</i>	95
4.3	<i>Carbonyl Compounds via EPA Compendium Method TO-11a</i>	96
4.3.1	<i>General Description of Sampling Method and Analytical Method</i>	96
4.3.2	<i>Minimizing Bias</i>	96
4.3.3	<i>Carbonyls Precision</i>	97
4.3.3.1	<i>Sampling Precision</i>	97
4.3.3.1.1	<i>Collocated Sample Collection</i>	97
4.3.3.1.2	<i>Duplicate Sample Collection</i>	98
4.3.3.2	<i>Laboratory Precision</i>	99
4.3.4	<i>Managing Ozone</i>	99
4.3.4.1	<i>Copper Tubing Denuder/Scrubber</i>	99
4.3.4.2	<i>Sorbent Cartridge Scrubbers</i>	100
4.3.4.3	<i>Other Ozone Scrubbers</i>	101
4.3.4.3.1	<i>Cellulose Filter Ozone Scrubbers</i>	101
4.3.4.3.2	<i>Modified Dasibi™ Ozone Scrubber</i>	101
4.3.5	<i>Collection Media</i>	101
4.3.5.1	<i>Lot Evaluation and Acceptance Criteria</i>	102
4.3.5.2	<i>Cartridge Handling and Storage</i>	102
4.3.5.3	<i>Damaged Cartridges</i>	103
4.3.5.4	<i>Cartridge Shelf Life</i>	103
4.3.6	<i>Method Detection Limits</i>	103
4.3.7	<i>Carbonyls Sample Collection Equipment, Certification, and Maintenance</i>	104
4.3.7.1	<i>Sampling Equipment</i>	104
4.3.7.1.1	<i>Sampling Unit Zero Check (Positive Bias Check)</i>	104
4.3.7.1.2	<i>Carbonyls Sampling Unit Flow Calibration</i>	105
4.3.7.1.3	<i>Moisture Management</i>	107
4.3.7.2	<i>Sampling Train Configuration and Presample Purge</i>	108
4.3.7.3	<i>Carbonyl Sampling Inlet Maintenance</i>	108
4.3.8	<i>Sample Collection Procedures and Field Quality Control Samples</i>	108
4.3.8.1	<i>Sample Collection Procedures</i>	108

	4.3.8.1.1	Sample Setup	109
	4.3.8.1.2	Sample Retrieval	109
	4.3.8.1.3	Sampling Schedule and Duration	110
4.3.8.2		Field Quality Control Samples	110
	4.3.8.2.1	Field Blanks	110
	4.3.8.2.2	Trip Blanks	111
	4.3.8.2.3	Collocated Samples	111
	4.3.8.2.4	Duplicate Samples	112
	4.3.8.2.5	Field Matrix Spikes	112
	4.3.8.2.6	Breakthrough Samples	112
4.3.9		Carbonyls Extraction and Analysis	113
	4.3.9.1	Analytical Interferences and Contamination	113
	4.3.9.1.1	Analytical Interferences	113
	4.3.9.1.2	Labware Cleaning	113
	4.3.9.1.3	Minimizing Sources of Contamination	113
	4.3.9.2	Reagents and Standard Materials	114
	4.3.9.2.1	Solvents	114
	4.3.9.2.2	Calibration Stock Materials	114
	4.3.9.2.3	Secondary Source Calibration Verification Stock Materials	114
	4.3.9.2.4	Holding Time and Storage Requirements	114
	4.3.9.3	Cartridge Holding Time and Storage Requirements	114
	4.3.9.4	Cartridge Extraction	115
	4.3.9.4.1	Laboratory Quality Control Samples	115
	4.3.9.4.2	Cartridge Extraction Procedures	116
	4.3.9.5	Analysis by HPLC	116
	4.3.9.5.1	Instrumentation Specifications	116
	4.3.9.5.2	Initial Calibration	117
	4.3.9.5.3	Secondary Source Calibration Verification Standard	118
	4.3.9.5.4	Continuing Calibration Verification	118
	4.3.9.5.5	Replicate Analysis	118
	4.3.9.5.6	Compound Identification	118
	4.3.9.5.7	Data Review and Concentration Calculations	119
	4.3.10	Summary of Quality Control Parameters	121
	4.3.11	References	123
4.4		PM ₁₀ Metals Sample Collection and Analysis	124
	4.4.1	Summary of Method	124
	4.4.2	Advantages and Disadvantages of High Volume and Low Volume Sample Collection	125
	4.4.2.1	Low Volume Sampling	125
	4.4.2.2	High Volume Sampling	125
	4.4.3	Minimizing Contamination, Filter Handling, and Filter Inspection	126
	4.4.3.1	Minimizing Contamination	126
	4.4.3.2	Filter Handling	126
	4.4.3.3	Filter Inspection	127

4.4.4	Precision – Sample Collection and Laboratory Processing	127
4.4.4.1	<i>Sample Collection Precision</i>	127
4.4.4.2	<i>Laboratory Precision</i>	127
4.4.4.2.1	<i>Low Volume Teflon® Filter Laboratory Precision</i>	127
4.4.4.2.2	<i>High Volume QFF Laboratory Precision</i>	127
4.4.5	Field Blanks	128
4.4.6	Labware Preparation for Digestion and Analysis	128
4.4.7	Reagents for Metals Digestion and Analysis	129
4.4.8	Method Detection Limits	129
4.4.8.1	<i>Teflon® Filter MDL</i>	129
4.4.8.2	<i>QFF MDL</i>	129
4.4.9	Low Volume Sample Collection and Digestion	130
4.4.9.1	<i>Air Sampling Instruments</i>	130
4.4.9.2	<i>Flow Calibration</i>	130
4.4.9.3	<i>Filter Media</i>	131
4.4.9.3.1	<i>Lot Background Determination</i>	131
4.4.9.4	<i>Filter Sampling, Retrieval, Storage, and Shipment</i>	131
4.4.9.4.1	<i>Sampling Schedule and Duration</i>	131
4.4.9.5	<i>Teflon® Filter Digestion</i>	131
4.4.9.5.1	<i>Laboratory Digestion QC Samples</i>	131
4.4.9.5.2	<i>Digestion Procedure</i>	132
4.4.9.5.2.1	<i>Hot Block Digestion</i>	132
4.4.9.5.2.2	<i>Microwave Digestion</i>	133
4.4.9.5.2.3	<i>Acid Sonication</i>	134
4.4.10	High Volume Sample Collection and Digestion	135
4.4.10.1	<i>Air Sampling Instruments</i>	135
4.4.10.2	<i>Flow Calibration</i>	135
4.4.10.3	<i>Filter Media</i>	135
4.4.10.3.1	<i>Lot Background Determination</i>	135
4.4.10.4	<i>Filter Sampling, Retrieval, Storage, and Shipment</i>	136
4.4.10.4.1	<i>Sampling Schedule and Duration</i>	137
4.4.10.5	<i>QFF Digestion</i>	137
4.4.10.5.1	<i>Laboratory Digestion QC Samples</i>	137
4.4.10.5.2	<i>Digestion Procedure</i>	138
4.4.10.5.2.1	<i>Hot Block Digestion</i>	139
4.4.10.5.2.2	<i>High Volume QFF Microwave Digestion</i>	139
4.4.10.5.2.3	<i>High Volume QFF Acid Sonication</i>	139
4.4.11	PM ₁₀ Metals Analysis by ICP/MS – EPA IO-3.5	139
4.4.11.1	<i>ICP/MS Instrumentation</i>	139
4.4.11.2	<i>ICP/MS Interferences</i>	139
4.4.11.3	<i>Preparation of Calibration Standards for ICP/MS Analysis</i>	140
4.4.11.3.1	<i>Primary Calibration Standards</i>	140
4.4.11.3.2	<i>Secondary Source Calibration Verification Standard</i>	140
4.4.11.4	<i>Internal Standards</i>	141

4.4.11.5	<i>Tuning Solutions</i>	141
4.4.11.6	<i>ICP/MS Warm Up, MS Tuning, and Setup</i>	141
4.4.11.7	<i>ICP/MS Calibration and Analytical Sequence Batch</i>	142
4.4.11.7.1	<i>Initial Calibration</i>	142
4.4.11.7.2	<i>Initial Calibration Verification</i>	143
4.4.11.7.3	<i>Initial Calibration Blank</i>	143
4.4.11.7.4	<i>Interference Check Standard</i>	143
4.4.11.7.5	<i>Continuing Calibration Verification</i>	143
4.4.11.7.6	<i>Continuing Calibration Blank</i>	144
4.4.11.7.7	<i>Laboratory Digestion Batch Quality Control Samples</i>	144
4.4.11.7.8	<i>Serial Dilution</i>	144
4.4.11.7.9	<i>Replicate Analysis</i>	144
4.4.11.8	<i>ICP/MS Data Review and Concentration Calculations</i>	144
4.4.11.8.1	<i>Concentration Calculations for Low Volume Sampling</i>	145
4.4.11.8.2	<i>Reporting of Concentrations for High Volume Sampling</i>	145
4.4.12	<i>Summary of Method Quality Control Requirements</i>	146
4.4.13	<i>References</i>	149
4.5	<i>Collection and Analysis of PAHs via EPA Compendium Method TO-13A</i>	150
4.5.1	<i>Summary of Method</i>	150
4.5.2	<i>Sample Collection Equipment</i>	150
4.5.2.1	<i>Sampler Flow Calibration and Verification</i>	151
4.5.2.2	<i>Sampling Unit Maintenance</i>	151
4.5.3	<i>Sampling Media and Their Preparation</i>	152
4.5.3.1	<i>Glassware Cleaning</i>	153
4.5.3.2	<i>Cartridge Preparation</i>	153
4.5.3.3	<i>Field Surrogate Addition</i>	153
4.5.4	<i>PAH Sampling</i>	154
4.5.4.1a	<i>Sampling Schedule and Duration</i>	154
4.5.4.1b	<i>Retrieval, Storage, and Transport of QFFs and Cartridges</i>	154
4.5.4.2	<i>Field Blanks</i>	155
4.5.4.3	<i>Collocated Sampling</i>	155
4.5.5	<i>PAH Extraction and Analysis</i>	156
4.5.5.1	<i>Reagents and Standard Materials</i>	156
4.5.5.1.1	<i>Solvents</i>	156
4.5.5.1.2	<i>Calibration Stock Materials</i>	156
4.5.5.1.2.1	<i>Secondary Source Calibration Verification Stock Material</i>	156
4.5.5.1.3	<i>Internal Standards</i>	156
4.5.5.1.4	<i>Surrogate Compounds</i>	156
4.5.5.1.4.1	<i>Field Surrogate Compounds</i>	157
4.5.5.1.4.2	<i>Extraction Surrogate Compounds</i>	157
4.5.5.2	<i>Hold Times and Storage Requirements</i>	157
4.5.5.3	<i>Extraction, Concentration, and Cleanup</i>	157

4.5.5.3.1	<i>Soxhlet Extraction</i>	157
4.5.5.3.2	<i>Accelerated Solvent Extraction</i>	157
4.5.5.3.3	<i>Extract Concentration and Cleanup</i>	158
4.5.5.3.3.1	<i>Extract Concentration</i>	158
4.5.5.3.3.1.1	Concentration via Kuderna-Danish.....	158
4.5.5.3.3.1.2	Concentration via Nitrogen Blowdown	159
4.5.5.3.3.2	<i>Extract Cleanup</i>	159
4.5.5.4	<i>PAH Method Detection Limits</i>	159
4.5.5.5	<i>PAH Analysis via GC/MS</i>	160
4.5.5.5.1	<i>GC/MS Instrumentation</i>	160
4.5.5.5.2	<i>Tuning of the MS</i>	160
4.5.5.5.3	<i>Calibration of the GC/MS</i>	160
4.5.5.5.4	<i>Secondary Source Calibration Verification</i>	162
4.5.5.5.5	<i>Continuing Calibration Verification</i>	162
4.5.5.5.6	<i>Analysis of QC Samples and Field Samples</i>	162
4.5.5.5.7	<i>Compound Identification</i>	162
4.5.5.5.8	<i>Internal Standards Response</i>	163
4.5.5.5.9	<i>Surrogate Evaluation</i>	163
4.5.5.5.10	<i>Data Review and Concentration Calculations</i>	163
4.5.6	Summary of Quality Control Parameters.....	164
4.5.7	References.....	166
5.0:	METEOROLOGICAL MEASUREMENTS.....	167
6.0:	DATA HANDLING	168
6.1	Data Collection.....	168
6.2	Data Backup	168
6.3	Recording of Data	169
6.3.1	Paper Records	169
6.3.2	Electronic Data Capture.....	169
6.3.3	Error Correction.....	169
6.3.3.1	<i>Manual Integration of Chromatographic Peaks</i>	169
6.4	Numerical Calculations	170
6.4.1	Rounding.....	170
6.4.2	Calculations Using Significant Digits.....	170
6.4.2.1	<i>Addition and Subtraction</i>	170
6.4.2.2	<i>Multiplication and Division</i>	171
6.4.2.3	<i>Standard Deviation</i>	171
6.4.2.4	<i>Logarithms</i>	171
6.5	In-house Control Limits	171
6.5.1	Warning Limits	172
6.5.2	Control Limits.....	172
6.6	Negative Values	172
6.6.1	Negative Concentrations.....	172
6.6.2	Negative Physical Measurements	172

7.0: DATA VALIDATION TABLES	173
7.1 VOCs via EPA Compendium Method TO-15.....	174
7.2 Carbonyls via EPA Compendium Method TO-11A	181
7.3 Metals via EPA Compendium Method IO 3.1 and IO 3.5	187
7.4 PAHs via EPA Compendium Method TO-13A	196

LIST OF FIGURES

Figure 3.1-1. Example Corrective Action Report.....	26
Figure 4.1-1. Graphical Representation of the MDL and Relationship to a Series of Blank Measurements in the Absence of Background Contamination	48
Figure 4.1-2. Graphical Representation of the MDL and Relationship to a Series of Measurements at the MDL Value	49
Figure 4.2-1. Collocated and Duplicate VOC Canister Sample Collection.....	67
Figure 4.2-2. Qualitative Identification of GC/MS Target Analytes.....	90
Figure 4.2-3. Determination of Chromatographic Peak Signal-to-Noise Ratio.....	91
Figure 4.4-1. Portioning of QFF Strips for Digestion.....	138

LIST OF TABLES

Table 1.2-1. Analytes of Principle Interest for the NATTS Program.....	3
Table 2.1-1. Assessments of Precision through Field and Laboratory Activities.....	13
Table 2.4-1. Sampling Unit Inlet Vertical Spacing Requirements	18
Table 2.4-2. Sampling Unit Inlet Required Minimum Distances from Roadways.....	19
Table 3.3-1. Calibration and Calibration Check Frequency Requirements for Standards and Critical Instruments	28
Table 3.3-2. AQS Qualifier Codes Appropriate for NATTS Data Qualification	42
Table 3.3-3. Required AQS Quality Assurance Qualifier Flags for Various Concentrations Compared to an Agency's MDL and SQL.....	43
Table 4.1-1. Concentrations of the NATTS Core Analytes Corresponding to a 10 ⁻⁶ Cancer Risk, a Noncancer Risk at a HQ of 0.1, and to the MDL MQO	52
Table 4.1-2. One-sided Student's T Values at 99% Confidence Interval.....	55
Table 4.1-3. K-values for n Replicates	60
Table 4.2-1. VOC Target Compounds and Associated Chemical Abstract Service (CAS) Number via Method TO-15.....	64
Table 4.2-2. Required BFB Key Ions and Ion Abundance Criteria.....	86
Table 4.2-3. Summary of Quality Control Parameters for NATTS VOCs Analysis.....	93
Table 4.3-1. Carbonyl Target Compounds and Associated Chemical Abstract Service (CAS) Number via Method TO-11A.....	96
Table 4.3-2. Maximum Background per Lot of DNPH Cartridge.....	102
Table 4.3-3. Carbonyls Field Blank Acceptance Criteria.....	111
Table 4.3-4. Summary of Quality Control Parameters for NATTS Carbonyls Analysis	121
Table 4.4-1. NATTS Program Metals Elements and Associated CAS Numbers.....	125

Table 4.4-2. Example ICP/MS Analysis Sequence	142
Table 4.4-3. Method Criteria Parameters for NATTS Metals Analysis	147
Table 4.5-1. PAHs and Associated Chemical Abstract Numbers (CAS)	151
Table 4.5-2. DFTPP Key Ions and Abundance Criteria	160
Table 4.5-3. Summary of Quality Control Parameters for NATTS PAH Analysis.....	164

APPENDICES

Appendix A Draft Report on Development of Data Quality Objectives (DQOs) For The National Ambient Air Toxics Trends Monitoring Network.....	202
Appendix B NATTS AQS Reporting Guidance for Quality Assurance Samples	235
Appendix C EPA Rounding Guidance Provided By EPA Region IV	243

ACRONYMS AND ABBREVIATIONS

ACN	acetonitrile
ADQ	audit of data quality
AIRS	Aerometric Information Retrieval System
amu	atomic mass unit
ANP	annual network plan
ANSI	American National Standards Institute
AQS	Air Quality System
ASE	accelerated solvent extraction
ASQ	American Society for Quality
BFB	bromofluorobenzene
CAA	Clean Air Act
CAL	calibration
CAR	corrective action report
CARB	California Air Resources Board
CAS	Chemical Abstracts Service
CCB	continuing calibration blank
CCV	continuing calibration verification
CDCF	canister dilution correction factor
CDS	chromatography data system
CFR	Code of Federal Regulations
COA	certificate of analysis
COC	chain of custody
Cr6+	hexavalent chromium
CV	coefficient of variation
DART	Data Analysis and Reporting Tool
DB	dilution blank
DFTPP	decafluorotriphenylphosphine
DL	detection limit
DNPH	2,4-dinitrophenylhydrazine
DOC	demonstration of capability
DQI	data quality indicator
DQ FAC	Federal Advisory Committee on Detection and Quantitation Approaches and Uses in Clean Water Act Programs
DQO	data quality objective
ECTD	extended cold trap dehydration
EPA	United States Environmental Protection Agency
ESMB	extraction solvent method blank
eV	electron volt

FAA	flame atomic absorption
FAEM	flexible approaches to environmental measurement
FID	flame ionization detector
FRM	federal reference method
g	gram(s)
GC	gas chromatograph
GC/MS	gas chromatograph/mass spectrometry
GFAA	graphite furnace atomic absorption spectrometry
GPRA	Government Performance Results Act
HAP	hazardous air pollutant
HCF	hydrocarbon-free
Hg	mercury
HPLC	high performance liquid chromatograph
HQ	hazard quotient
IB	instrument blank
IC	ion chromatograph
ICAL	initial calibration
ICB	initial calibration blank
ICP/AES	inductively coupled plasma/atomic emission spectroscopy
ICP/MS	inductively coupled plasma/mass spectrometer
ICS	interference check standard
ICV	initial calibration verification
ID	identifier
IDCF	instrument dilution correction factor
in.	inch(es)
IS	internal standard
K-D	Kuderna-Danish
KI	potassium iodide
L	liter(s)
LCS	laboratory control sample
LCSD	laboratory control sample duplicate
LFB	laboratory fortified blank
LIMS	laboratory information management system
LPM	liter(s) per minute
M	molar
m	meter(s)
m ³	cubic meter(s)
m/z	mass to charge
MB	method blank
MDL	method detection limit

MFC	mass flow controller
mg	milligram(s)
min	minute(s)
mL	milliliter(s)
mm	millimeter(s)
mM	millimolar
MPT	microscale purge and trap
MQO	measurement quality objective
MS	mass spectrometer or matrix spike
MUR	method update rule
μg	microgram(s)
μL	microliter(s)
μm	micrometer(s)
n	number
NAAQS	national ambient air quality standards
NATTS	National Air Toxics Trends Station
ng	nanograms(s)
nm	nanometer(s)
O ₂	oxygen molecule
O ₃	ozone molecule
OAQPS	Office of Air Quality Planning and Standards (EPA)
OH ⁻	hydroxide ion
PAH	polycyclic aromatic hydrocarbon
PM	particulate matter
PM _{2.5}	particulate matter with aerodynamic diameter ≤ 2.5 microns
PM ₁₀	particulate matter with aerodynamic diameter ≤ 10 microns
POC	parameter occurrence code
ppb	part(s) per billion
ppbv	part(s) per billion by volume
ppm	part(s) per million
ppmv	part(s) per million by volume
psi	pound(s) per square inch
psia	pound(s) per square inch absolute
psig	pound(s) per square inch gauge
PT	proficiency test
PTFE	polytetrafluoroethylene
PUF	polyurethane foam
QA	quality assurance
QAPP	quality assurance project plan
QC	quality control
QFF	quartz fiber filter
QL	quantitation limit

QMP	quality management plan
QSA	quality systems audit
RB	reagent blank
RBS	reagent blank spike
RH	relative humidity
RPD	relative percent difference
RRF	relative response factor
RRT	relative retention time
RSD	relative standard deviation
RT	retention time
SB	solvent blank
SIM	selective ion monitoring
SLT	state, local, or tribal agency
SMB	solvent method blank
SOP	standard operating procedure
SQL	sample quantitation limit
SSCV	second source calibration verification
STP	temperature and pressure
SVOC	semi-volatile organic compound
TAD	technical assistance document
TOF	time of flight
TSA	technical systems audit
TTP	through the probe
UATS	urban air toxics strategy
UV	ultraviolet
VOC	volatile organic compound
v/v	volume per volume

1.0: INTRODUCTION

1.1 Background

Hazardous air pollutants (HAPs), or air toxics, are regulated under the Clean Air Act (CAA) as amended in 1990 and include a list of 189 toxic pollutants associated with adverse health effects. Such HAPs are emitted by numerous stationary and mobile sources. The U.S. Environmental Protection Agency (EPA) Government Performance Results Act (GPRA) commitments specify a goal of reducing air toxics emissions by 75% from 1993 levels to significantly reduce the potential for human health risk.

The National Air Toxics Trends Station (NATTS) Program was developed to fulfill the need for long-term ambient air toxics monitoring data required to assess attainment of GPRA commitments. The NATTS network was designed to generate data of a known, consistent, and standardized quality sufficient to enable the identification of spatial, and, more importantly, long-term temporal trends in the concentrations of air toxics. This technical assistance document (TAD) presents best practices and sets forth requirements for the collection and reporting of NATTS network air toxics data and is intended as an aid to the agencies responsible for implementing the NATTS Program. EPA recognizes that the partnership between the EPA and state and local air monitoring agencies is intrinsic to attaining the goal of the NATTS Program to generate high quality data needed to accomplish the end goal of trends detection. This TAD includes information on the implementation and maintenance of the necessary quality system, on the collection and analysis of air samples, and on the reporting of results to EPA's Air Quality System (AQS) database.

1.2 Target Analytes: Analytes of Critical Concern/Risk Drivers

While it is impractical to measure all HAPs at all monitoring sites, HAPs have been assigned by analyte class to a tiered system according to their relative toxicity. The 1990 CAA amendments required EPA to develop a subset of the 189 toxic pollutants identified in Section 112 that have the greatest impact on the public and the environment in urban areas. The resulting subset of air toxics consisted of 33 HAPs which are identified in the Integrated Urban Air Toxics Strategy (UATS)¹, commonly referred to as the Urban HAP List. This subset of 33 HAPs covers a variety of inhalation exposure periods (acute/chronic), exposure pathways (inhalation, dermal, ingestion), and associated adverse health effects (cancer/non-cancer). However, the NATTS Program is primarily concerned with traditional inhalation pathway exposures of more ubiquitous HAPs, and is focused on measuring HAPs which have available and cost-effective measurement methods. As such, 18 of the 33 UATS HAPs were selected as core HAPs for the NATTS Program. HAPs omitted from the UATS list include those for which analysis methods are less cost-efficient or less reliable and those HAPs deemed to have a lesser impact on inhalation exposure but a greater impact on the welfare of watersheds and water bodies through airborne deposition. Also omitted from the NATTS program were those HAPs which are categorized as persistent bio-accumulative compounds (PBTs) such as pesticides, mercury, polychlorinated biphenyls (PCBs), and dioxins.²

Hexavalent chromium was removed from the list of NATTS core HAPs due to it being a local source-driven pollutant (and not ubiquitous) and due to the preponderance of non-detect results on a national scale which provided little useful data. Sites are not required to, but may elect to, collect and report hexavalent chromium data. With the removal of hexavalent chromium, the 17 remaining UATS HAPs included polycyclic organic matter (POM), which was added later (in 2007) as speciated polycyclic aromatic hydrocarbons (PAHs). The replacement of POM with naphthalene and benzo(a)pyrene brought the list of required NATTS core HAPs to 18.

Sixty of the 189 HAPs have been selected as “Analytes of Principle Interest” for the NATTS Program; these 60 belong to one of four different analyte classes according to the method by which they are typically measured, i.e. volatile organic compounds (VOCs), carbonyls, metals, and (PAHs). These 60 “Analytes of Principle Interest” include 17 (18 when replacing POM with naphthalene and benzo(a)pyrene) of the UATS HAPs (mentioned previously) and are listed in Table 1.2-1 along with their analyte classes and concentrations corresponding to a 10^{-6} cancer risk and a noncancer risk at a hazard quotient (HQ) of 0.1. Of these 60 HAPs, 18 have been identified as major risk drivers based on a relative ranking performed by EPA and have been designated NATTS Core, or Tier I, analytes; these compounds must be measured at all NATTS sites. The remaining 42 Tier II HAPs are highly desired and should be measured and reported. EPA recognizes that additional resources are required to provide quality-assured data for the additional Tier II analytes; however, given that these methods are already conducted to measure the Tier I Core analytes, data for many of Tier II analytes can be reported with modest additional resource input.

Table 1.2-1. Analytes of Principle Interest for the NATTS Program

HAP	Analyte Class and Collection and Analysis Method	Tier	10 ⁻⁶ Cancer Risk Concentration (µg/m ³)	Noncancer Risk [Hazard Quotient = 0.1] Concentration (µg/m ³)
acrolein	VOC by TO-15	I (UATS)	-	0.002
tetrachloroethylene		I (UATS)	3.8 ^a	4 ^a
benzene		I (UATS)	0.13	3
carbon tetrachloride		I (UATS)	0.17	19
chloroform		I (UATS)	-	9.8
trichloroethylene		I (UATS)	0.21 ^a	0.2 ^a
1,3-butadiene		I (UATS)	0.03	0.2
vinyl chloride		I (UATS)	0.11	10
acetonitrile		II	-	6
acrylonitrile		II (UATS)	0.015	2
bromoform		II	0.91	-
carbon disulfide		II	-	70
chlorobenzene		II	100	-
chloroprene		II	-	0.7
p-dichlorobenzene		II	0.091	80
cis-1,3-dichloropropene		II (UATS)	0.3	2
trans-1,3-dichloropropene		II (UATS)	0.3	2
ethyl acrylate		II	0.071	-
ethyl benzene		II	-	100
hexachloro-1,3-butadiene		II	0.0022	9
methyl ethyl ketone		II	-	500
methyl isobutyl ketone		II	-	300
methyl methacrylate		II	-	70
methyl tert-butyl ether		II	3.8	300
methylene chloride		II (UATS)	2.1	100
styrene		II	-	100
1,1,2,2-tetrachloroethane		II (UATS)	0.017	-
toluene		II	-	40
1,1,2-trichloroethane		II	0.063	40
1,2,4-trichlorobenzene		II	-	20
m&p-xylenes	II	-	10	
o-xylene	II	-	10	
formaldehyde	carbonyl by TO-11A	I (UATS)	0.08 ^a	0.08 ^a
acetaldehyde		I (UATS)	0.45	0.9

Table 1.2-1. Analytes of Principle Interest for the NATTS Program (Continued)

HAP	Analyte Class and Collection and Analysis Method	Tier	10 ⁻⁶ Cancer Risk Concentration (µg/m ³)	Noncancer Risk [Hazard Quotient = 0.1] Concentration (µg/m ³)
nickel	metal by IO-3.1 and IO-3.5	I (UATS)	0.0021	0.009
arsenic		I (UATS)	0.00023	0.003
cadmium		I (UATS)	0.00056	0.002
manganese		I (UATS)	-	0.005
beryllium		I (UATS)	0.00042	0.002
lead		I (UATS)	-	0.015
antimony		II	-	0.02
chromium		II (UATS)	0.00008	0.01
cobalt		II	-	0.01
selenium		II	-	2
naphthalene		PAH by TO-13A	I (UATS ^b)	0.029
benzo(a)pyrene	I (UATS ^b)		0.00091	0.3
acenaphthene	II (UATS ^b)		-	0.3
acenaphthylene	II (UATS ^b)		-	0.3
anthracene	II (UATS ^b)		-	0.3
benz(a)anthracene	II (UATS ^b)		0.0091	0.3
benzo(b)fluoranthene	II (UATS ^b)		0.0091	0.3
benzo(e)pyrene	II (UATS ^b)		-	0.3
benzo(k)fluoranthene	II (UATS ^b)		0.0091	0.3
chrysene	II (UATS ^b)		0.091	0.3
dibenz(a,h)anthracene	II (UATS ^b)		0.0091	0.3
fluoranthene	II (UATS ^b)		-	0.3
fluorene	II (UATS ^b)		-	0.3
indeno(1,2,3-cd)pyrene	II (UATS ^b)		0.0091	0.3
phenanthrene	II (UATS ^b)		-	0.3
pyrene	II (UATS ^b)		-	0.3

^a These values are per the NATTS Workplan Template, March 2015 ³

^b PAHs compounds included in the UATS list as polycyclic organic matter (POM)

1.3 Importance of Adherence to Guidelines

The overall data quality objective (DQO) of the NATTS Program is to detect trends in HAP concentrations covering rolling three-year periods with uniform certainty across the 27-site network with a coefficient of variation (CV) not to exceed 15 percent.⁴ Stated another way, the DQO is to be able to detect a 15% difference (trend) in non-overlapping three-year periods within acceptable levels of decision error. This is accomplished by generating representative concentration data for the various HAPs with appropriate sensitivity within acceptable limits of imprecision and bias. For overall trends to be discernable, concentration data must be generated with methods which meet minimum performance criteria. The DQO, data quality indicators

(DQIs), and their associated measurement quality objectives (MQOs), or acceptance criteria, are presented in detail in Sections 2.1 and 3.2. EPA recognizes there is a disconnect in the NATTS bias MQO, which may not exceed 25%, and bias criteria in individual methods, notably TO-13A and TO-15, which exceed 25%. These methods are currently undergoing refinement by EPA's Office of Research and Development (ORD). For information regarding the determination of the DQO, DQIs, and MQOs, please refer to the following background reports and 2013 DQO reassessment report:

- Air Toxics Monitoring Concept Paper, Revised Draft February 29, 2000:
<https://www3.epa.gov/ttnamti1/files/ambient/airtox/cncp-sab.pdf>
- Draft Report on Development of Data Quality Objectives (DQOs) for the National Ambient Air Toxics Trends Monitoring Network, September 27, 2002
(Appendix A of this TAD)
- Analysis, Development, and Update of the National Air Toxics Trends Stations (NATTS) Network Program-Level Data Quality Objective (DQO) and Associated Method Quality Objectives (MQOs), Final Report, June 13, 2013
<https://www3.epa.gov/ttnamti1/files/ambient/airtox/natstdqo20130613.pdf>

Together, these documents provide a roadmap for determining and verifying the NATTS DQO and supporting MQOs.

A review of data during Phase I of the NATTS pilot project identified that variations in sampling, analysis, data reporting, and quality assurance resulted in a large amount of data inconsistency.² This TAD was developed and revised to increase consistency across the network and facilitate attainment of the NATTS DQO. Failure to attain the prescribed NATTS MQOs limits the ability to detect trends. Trends must be assessed so that EPA, as outlined in the EPA's Integrated Urban Air Strategy, may verify that the cumulative health risks associated with air toxics are in fact decreasing.⁵

1.4 Overview of TAD Sections

This document is organized so as to present guidance and requirements in the likely order in which they are needed when establishing a network site or network sites and laboratory, i.e., planning, implementation, and data verification. Background information, the NATTS DQO, and the framework and requirements for quality systems are addressed first, followed by collection and analysis of air samples, with data handling and validation tables completing the document. Each section is briefly described below.

1. Background – Brief overview of the history of the NATTS Program, NATTS analytes, and critical changes from Revision 2
2. Metrics Defining Data Quality for the NATTS Program – Importance of data consistency, NATTS monitoring objectives, quality systems, and siting criteria

3. Quality Assurance and Quality Control – Quality Assurance Project Plan (QAPP) development, QAPP elements including standard operating procedures (SOPs), corrective action, equipment calibration, document control, training, chain of custody (COC), traceability, labeling, control charting, software, records review, data verification and validation, and air quality subsystem (AQS) reporting
4. Collection and Analysis Methods – method detection limit (MDL) procedures, VOCs, carbonyls, PM₁₀ metals, and PAHs
5. Meteorology – Brief description of required meteorological measurements
6. Data Handling – Procedures and policies for collection, manipulation, backup, archival, and calculations
7. Data Validation Tables – A series of tables detailing method specific critical criteria

1.5 Critical Changes and Updates from Revision 2 of the NATTS TAD

With this revision, the NATTS TAD has not only been reorganized and streamlined, but it has been substantially updated compared to Revision 2. Specific changes include:

- Specification of detailed requirements and recommendations for quality system development and implementation
- Specification of calibration requirements and recommendations for all instruments, including support equipment
- Recommendations for conducting and documenting of training
- Revision to the MDL determination procedure to be inclusive of the contribution from the collection media background
- Clarification of precision for sample collection and analysis
- Relaxation of certain VOCs sample collection requirements
- Provision of updated guidance on collection and analysis of VOCs, carbonyls, PM₁₀ metals, and PAHs
- Exclusion of hexavalent chromium sampling and analysis methods
- Clarification on data handling practices
- Provision of data validation templates

Updating the guidance and requirements for the air sampling and analysis methods is the primary goal of this TAD revision. The secondary goal is to provide a more user-friendly guidance document with discrete sections organized in a manner so as to allow users to quickly locate the desired information. Of note, data validation template tables have been provided as an appendix in Section 7.

With the removal of hexavalent chromium as a NATTS core HAP in June 2013, guidance for sample collection and analysis for this analyte are not provided within this TAD revision.

1.6 Good Scientific Laboratory Practices

Good scientific practices, including instrument calibration and proper recording of observations, measurements, and instrument conditions, are equally important in both the field and in the laboratory. Such practices are necessary to generate data which are consistent, comparable, standardized, traceable, and defensible. Appropriate aspects of good laboratory and field practices are to be detailed in each agency's NATTS quality system. The need for, and examples of such practices are given below and in Section 2.

1.6.1 Data Consistency and Traceability. To be able to verify that the NATTS network generates data of quality sufficient to evaluate the main NATTS Program DQO, data collection and generation activities must be traceable to calibrated instruments, certified standards, and to activities conducted by individuals with the appropriate and documented training. Traceability in this case refers to ensuring the existence of a documentation trail which allows reconstruction of the activities performed to collect and analyze the sample and to the certified standards and calibrated instrumentation employed to determine analyte concentrations. To specifically ensure attainment of overall network bias requirements, each reported concentration must be traceable to a measurement of known accuracy, be it from an analytical balance, volumetric flask, gas chromatography/mass spectrometer (GC/MS), mass flow controller, critical orifice calibration plate, etc. Maintaining this traceability from sample collection to final results reporting assures that NATTS data are credible and defensible, and that the root cause of nonconformances may be found and corrected which thereby enables continuous improvement in NATTS program activities. Instrument calibration specifications and frequencies are provided in Section 3.

1.7 NATTS as the Model for Air Toxics Monitoring

Air toxics monitoring is an important, but often secondary, consideration for many air quality agencies. One reason for such is that there are no national ambient air quality standards (NAAQS) for air toxics for which regulatory compliance efforts would be required. Guidance for conducting air toxics sample collection and analysis is not as widely available as for criteria pollutants and is limited to performance-based compendium methods as compared to Federal Reference Methods (FRMs). This TAD is intended to primarily provide guidance and delineate requirements for NATTS sites and their associated laboratories; however, aspects of sampling, analysis, and quality assurance could be applied by agencies conducting air toxics monitoring outside of the NATTS network. This TAD incorporates feedback provided by the air toxics community with vast and varied experience conducting air toxics measurements. Feedback and input provided by the air toxics community were carefully reviewed and considered by a small workgroup of EPA and state/local/tribal (SLT) stakeholders in reviewing and revising this TAD. The NATTS network is a collaboration of SLT monitoring organizations with EPA. With an extensive network of experienced site operators and laboratory staff, the NATTS network strives to be the exemplar of air toxics monitoring.

1.8 References

1. Smith, R.L.; French, C.L.; Murphy, D.L.; Thompson, R. *Selection of HAPs under Section 112(k) of the Clean Air Act: Technical Support Document*; Integrated Urban Air Toxics Strategy (UATS), July 28, 1999.
2. *National Monitoring Strategy Air Toxics Component, Final Draft*. United States Environmental Protection Agency, July 2004. Available at (accessed October 18, 2016): <https://www3.epa.gov/ttnamti1/files/ambient/monitorstrat/atstrat804.pdf>
3. National Air Toxics Trends Station Work Plan Template. United States Environmental Protection Agency, Revised: March 2015. Available at (accessed October 18, 2016): <https://www3.epa.gov/ttn/amtic/files/ambient/airtox/nattsworkplantemplate.pdf>
4. *Quality Management Plan for the National Air Toxics Trends Stations*. Quality Assurance Guidance Document, EPA 454/R-02-006. September 2005. Available at (accessed October 18, 2016): <https://www3.epa.gov/ttnamti1/files/ambient/airtox/nattsqmp.pdf>

2.0: IMPORTANCE OF DATA CONSISTENCY

As the main goal of the NATTS Program is to detect long-term trends in ambient air toxics concentrations across the continental United States, sample data collected at each site must be comparable over time and from one site to the next. The ability to detect and evaluate trends on a nationwide basis requires the standardized operation of the NATTS Program based upon four key components:

- Known and specific MQOs for the program;
- Specified measurement (collection and analysis) methods performed in a standardized and consistent manner across the network;
- Known and specific acceptance criteria for various aspects of the specified monitoring methods; and
- Stability of monitoring sites including location and operation over the required period of time.

In short, each site's concentration data must meet the MQOs and be generated with standardized methods that are appropriately sensitive, show minimal bias, and are sufficiently precise. Moreover, the collected samples taken together must be representative of the ambient conditions at the site over the course of a year and the annual dataset must be adequately complete. If program MQOs are not attained at each site, the network data will not be consistent across all sites and the ability to detect concentration trends will be compromised. MQOs related to each of the specific DQIs are discussed in more detail in Section 2.1.

This TAD is written such that requirements are described as "must" and recommendations are described as "should." It is expected that monitoring agencies will make good faith efforts to comply with the requirements and adopt recommendations, where feasible.

2.1 Data Quality Objectives and Relationship to the Quality Assurance Project Plan

The DQO process ensures that the type, quantity, and quality of data used in decision making are appropriate to evaluate the overall DQO of the NATTS Program. Discussion of the determination of the NATTS DQO is addressed in the NATTS Quality Management Plan (QMP)¹ and is not reproduced here. Background information on the development of the NATTS DQO process is detailed in the initial DQO report² and a follow up assessment was completed in 2013³ to verify that the DQO and supporting MQOs remained applicable and suitable to attain network goals.

Each monitoring organization must develop a QAPP that describes the framework of the resources, responsible individuals, and actions to be taken to attain the NATTS DQO. QAPP development is described further in Section 3.3.

There is a single main DQO for the NATTS Program, which is:

To be able to detect a 15% difference (trend) between two successive 3-year annual mean concentrations (rolling averages) within acceptable levels of decision error.

This main DQO is directly related to demonstrating a reduction in health-based risk related to air toxics inhalation exposure. To achieve this main DQO, the NATTS Program network was designed to meet the following primary monitoring objectives, which are to:

- Measure concentrations of the NATTS Tier I core analytes and Tier II analytes of interest in ambient air at each NATTS site. These analytes are listed in Table 1.2-1.
- Generate data of sufficiently high and known quality that are nationally consistent. Such requires the implementation and maintenance of a robust and functional quality system, the proper execution of the applicable sampling and analysis methods, and that the specified methods provide sufficient sensitivity to obtain a limit of detection at or lower than that at which adverse health effects have been determined.
- Collect sufficient data to represent the annual average ambient concentrations of air toxics at each NATTS site. Collection of one sample every six days results in 60 or 61 samples per year exclusive of additional quality control (QC) samples such as blanks, collocated samples, duplicates, etc.

In addition to these primary monitoring objectives, the NATTS network was designed to address the following secondary monitoring objectives, which are to:

- Complement existing programs. The NATTS network is integrated with existing programs such as criteria pollutant monitoring, Photochemical Assessment Monitoring Stations (PAMS), National Core (NCore), etc., and to take advantage of efficiencies of scale to the extent that methodologies and operations are compatible. Establishment of NATTS sites at existing sites leverages the existing resources of experienced operators and infrastructure to achieve program objectives.
- Reflect community-oriented population exposure. Stationary monitors are sited to be representative of average concentrations within a 0.5- to 4-kilometer area (i.e., neighborhood scale). These neighborhood-scale measurements are more reflective of typical population exposure, can be incorporated in the estimation of long-term population risk, and are the primary component of the NATTS Program. Note that some NATTS sites may no longer truly represent neighborhood scale due to source or infrastructure changes. While new near-field sources may impact the measured concentrations, stability of the site location is necessary to detect trends which may still be discernable even when sites are impacted by such sources.
- Represent geographic variability. A truly national network must represent a variety of conditions and environments that will allow characterization of different emissions sources and meteorological conditions. The NATTS Program supports population risk characterization and the determination of the relationships between emissions and air quality under different circumstances, and allows for tracking of changes in emissions.⁴ National assessments must reflect the differences among cities and

between urban and rural areas for selected HAPs, so the network:

- Includes cities with high population risk (both major metropolitan areas and other cities with high or potentially high anticipated air toxics concentrations);
- Distinguishes differences within and between geographic regions (to describe characteristics of areas affected by high concentrations (e.g. urban areas) versus low concentrations (e.g. rural areas));
- Reflects the variability among pollutant patterns across communities; and
- Includes background monitoring (i.e., sites without localized sources).

The above monitoring objectives are supported by the DQIs as described in the following subsections:

2.1.1 Representativeness. To adequately characterize the ambient air toxics concentrations over the course of a year, sample collection must occur every six days per the national sampling calendar for a 24-hour period beginning and ending at midnight local standard time (without correction for daylight savings time, if applicable). This sample collection duration and frequency provides a sufficient number of data points to ensure that the collected data are representative of the annual average daily concentration at a given site. Collection methods are designed to efficiently capture airborne HAPs over this time period in order to measure concentrations representative of the ambient air during sample collection.

2.1.2 Completeness. Comparison of concentration data across sites and over time requires that a minimum number of samples be collected over the course of each calendar year. The MQO for completeness prescribes that $\geq 85\%$ of the annual air samples must be valid, equivalent to 52 of the annual 61 expected samples (51 during years when there are only 60 collection events).

A valid sample is one that was collected, analyzed, and reported to AQS without null flags. If a collected sample is voided or invalidated for any reason, a make-up sample collection should be attempted as soon as practical according to the make-up sampling policy below.

2.1.2.1 Make-up Sample Policy. Samples and sample results may be invalidated for a number of reasons. In all cases, the concentration data are entered in AQS flagged with a null code indicating the data are invalid. In order to increase the likelihood of attaining the completeness MQO of $\geq 85\%$, make-up samples should be collected when a sample or sample result is invalidated.

A replacement sample should be collected as close to the original sampling date as possible, and preferably before the next scheduled sampling date. When scheduling make-up sample collection, consideration should be given to minimize bias introduced to the annual concentration average due to differences in concentration from the originally scheduled sample date. Such considerations include concentration differences due to sample collection on a particular day of the week (weekday versus weekend) and potential seasonal effects. If it is not feasible to collect the make-up sample prior to the next scheduled sampling date, the sample should be collected within 30 days of the original sampling date. In all cases, the make-up sample should be

collected within the calendar year averaging period that starts January 1 and ends December 31. Note: For sampling units employing six-day timers, failure to reset the timer following a make-up sample can result in mistakenly collecting samples on dates that do not follow the national sampling calendar.

To summarize, make-up samples should be collected as close to the original sampling date as possible, and should be collected according to the following, in order of most preferable to least preferable:

1. Before the next scheduled sampling date
2. Within 30 days of the missed collection date
3. Within the calendar year.

In order to be temporally representative of the annual concentration at a given site, the sample dates must be as evenly distributed as possible to capture concentrations that fluctuate seasonally or according to weather patterns. It is not acceptable to delay make-up sampling until the end of the calendar year, as this may bias the data to be more seasonally than annually representative.

2.1.3 Precision. Reproducibility is a key component of ensuring concentration results at one site are comparable to those at other sites and are comparable over time. For the NATTS Program, precision of field and laboratory activities (inclusive of extraction and analysis) may be assessed by collection of collocated and/or duplicate field samples; the precision of laboratory handling and analysis may be estimated by the subdivision of a collected sample into preparation duplicates which are separately taken through all laboratory procedures (digestion or extraction and analysis) and includes instances in which target analytes may be added to a subsample to prepare matrix spike duplicates; and analytical precision is assessed by the replicate analysis of a sample or sample extract/digestate. Note that the previous revision of this TAD required that collocated and duplicate samples be analyzed in replicate. This has been relaxed to permit replicate analysis on any sample chosen by the laboratory. A summary of possible precision assessments is shown in Table 2.1-1. Precision sample collection and replicate analysis requirements will be detailed in each site's annual NATTS workplan.

The network MQO is based on an evaluation of at least an entire year's data. In all cases a coefficient of variance (CV) of $\leq 15\%$ must be met. For more information on how the CV is calculated, see the 2011-2012 NATTS Quality Assurance Annual Report.⁵ Note that this precision MQO is different than the precision acceptance criteria for the individual collection and analysis methods; imprecision of the latter may be permitted to be larger than 15%. Such method-specific precision requirements apply to comparing two measurements and do not apply to larger ($N > 2$) sample sets.

Table 2.1-1. Possible Assessments of Precision through Field and Laboratory Activities

HAP Class	Collocation *	Duplicate Field Samples *	Preparation (Digestion/Extraction) Duplicate	Matrix Spike Duplicate	Analysis Replicate
VOCs	yes	yes	no	no	yes
Carbonyls	yes	yes	no	no	yes
PM ₁₀ metals – high volume collection	yes	no	yes	yes	yes
PM ₁₀ metals – low volume collection	yes	no	no	no	yes
PAHs	yes	no	no	no	yes

*Note: Collection of collocated and duplicate field samples is highly desired, but not required, and will be detailed in the site’s annual workplan.

2.1.4 Bias. Bias is the difference of a measurement from a true or accepted value and can be negative or positive. As much as possible, bias should be minimized as biased data may result in incorrect conclusions and therefore incorrect decisions. Bias may originate in several places within the sample collection and analysis steps. Sources of sample collection bias include, but are not limited to, incorrectly calibrated flows or out-of-calibration sampling instruments, elevated and unaccounted for background on collection media, poorly maintained (dirty) sampling inlets and flow paths, and poor sample handling techniques resulting in contamination or loss of analyte. Sources of sample analysis bias include, but are not limited to, poor hygiene or technique in sample preparation, incorrectly calibrated or out of tolerance equipment used for standard materials preparation and analysis, and infrequent or inappropriate instrument maintenance leading to enhanced or degraded analyte responses.

2.1.4.1 Assessing Laboratory Bias - Proficiency Testing. Each laboratory analyzing samples generated at NATTS sites must participate in the NATTS proficiency testing (PT) program. PT samples for each of the four sample classes, VOCs, carbonyls, PM₁₀ metals, and PAHs, are generated at a frequency determined by EPA Office of Air Quality Planning and Standards (OAQPS), typically twice annually for each class. Participating laboratories are blind to the spiked concentrations and analyze the PT samples via methods and procedures identical to those employed for field-collected air samples.

PT target analytes, which include all Tier I analytes, among others, are identified in the following tables in Section 4:

VOCs	Table 4.2-1
Carbonyls	Table 4.3-1
PM ₁₀ Metals	Table 4.4-1
PAHs	Table 4.5-1

Each laboratory’s PT results, on an analyte-by-analyte basis, must be within $\pm 25\%$ of the assigned target value, defined as the NATTS laboratory average, excluding outliers. In the event

there is a problem with the NATTS laboratory average such as a contamination issue, the assigned target value may be changed to the nominal concentration or referee laboratory average, as applicable, and will be detailed in the PT results. Laboratories which fail to meet the bias acceptance criterion on an analyte-by-analyte basis must identify the root cause of the bias for the failed analyte, take corrective action, as appropriate, to eliminate the cause of the bias, and must evaluate the potential for bias in reported field sample data going back to last acceptable PT result. In the event of two consecutive failed PTs for a given analyte, laboratories must qualify field collected sample results as estimated when reported to AQS. EPA recognizes that the NATTS MQO bias criterion of $\pm 25\%$ established through the DQO process is narrower than the bias criteria for some of the analytical methods, namely TO-15 and TO-13A. In order for the main NATTS DQO to be achieved, the bias MQO criterion must be achieved.

2.1.4.2 Assessing Field Bias. The direction of the flow rate bias in carbonyls, PM₁₀ metals, and PAHs samplers is opposite that to the bias introduced in the reported concentrations. That is, flow rates which are biased low result in overestimation of air concentrations whereas flow rates which are biased high result in underestimation of air concentrations. As VOCs collection methods involve collection of whole air into the canister, the flow rate accuracy is of less importance and does not directly correlate to errors in measured concentrations. Rather, it is important that the flow rate into the canister be constant over the entire 24-hour collection period so as to best characterize the average burden of VOCs over the entire sampling duration.

Indicated flow rates for carbonyls and PAHs must be within $\pm 10\%$ of both the flow transfer standard and the design flow rate (where applicable). The indicated flow rate for the low volume PM₁₀ metals method must be within $\pm 4\%$ of the flow transfer standard and within $\pm 5\%$ of the design flow rate. The indicated flow rate for the high volume PM₁₀ metals method must be within $\pm 7\%$ of the transfer standard and within $\pm 10\%$ of the design flow rate. Failure to meet these criteria must result in corrective action including, but not limited to, recalibration of the sampling unit flow or resetting of flow linear regression response, where possible. Sampling units which cannot meet these flow accuracy specifications must not be utilized for sample collection. Additionally, following a failing calibration or calibration check, agencies must evaluate sample data collected since the last acceptable calibration or calibration check, and such data may be subject to invalidation. Corrective action is recommended for flow calibration checks which indicate flows approaching, but not exceeding the appropriate flow acceptance criterion. Calibration flow checks must be performed at minimum quarterly; however, to minimize risk of invalidation of data, monthly flow calibration checks are recommended.

Sampling bias for VOCs and carbonyls is also characterized by evaluating sample media collected by providing analyte-free zero air or nitrogen to the sampling unit (zero checking) and by providing a known concentration analyte stream to VOCs sampling units (known standard check). These zero checks and known standard checks are discussed further in Sections 4.2.5.5 and 4.3.7.1.1, for VOCs and carbonyls, respectively.

2.1.5 Sensitivity. Following promulgation of the CAA and its amendments, ambient air toxics concentrations have been decreasing. As concentrations decrease, they become increasingly difficult to measure and, as a result, measurement methods must become increasingly sensitive. Concurrent with decreases in ambient air toxics concentrations, health

risk assessments for exposures to air toxics are driving health risk-based concentrations lower, which also precipitates a need to increase method sensitivity. In order to ensure that methods are sufficiently sensitive, MDL MQOs have been established which prescribe the maximum allowable MDL for each required NATTS core/Tier I analyte. As concentrations for HAPs decrease in the ambient atmosphere and are measured closer to the MDL or below the MDL, this results in a decrease in the accuracy (decrease in precision and increase in bias) of the percent change estimate in evaluating a trend.

The MDL and sample quantitation limit ([SQL], defined as 3.18 times the MDL concentration) provide information on the concentration at which both positive identification and accurate quantification is expected, respectively. While all measured concentrations (even those less than the MDL) must be reported to AQS, the confidence associated with each reported concentration is correlated to its relationship to the corresponding MDL and SQL.

The SQL is equivalent to ten-fold the standard deviation of seven measurements of MDL samples, which was defined in draft EPA guidance in 1994⁶ as the minimum level (ML). The 3.18-fold was derived by dividing 10 standard deviations by 3.14 (the student's T value for 7 replicates). The MDL process in 40 Code of Federal Regulations (CFR) Part 136 Appendix B is protective against reporting false positives such that 99% of the measurements made at the determined MDL value are positively detected (determined to be different from the detectors response in the absence of the analyte), but does not attempt to characterize precision or address accuracy at the determined MDL concentration. The SQL (ML) concentration provides more confidence to the accuracy of the measurement with precision that is well-characterized.

MDL MQOs that must be met (as of the promulgation of this document in October 2016) are given in Table 4.1-1. Further discussion of MDL background, determination, and importance are discussed in in Section 4.1.

2.2 NATTS Workplan

Each year the EPA will submit a workplan to each agency conducting NATTS Program work covering the grant period from July 1 through June 30 of the following calendar year. This workplan details the sample collection, sample analysis, and data reporting responsibilities and the associated budget with which each agency must comply. The workplan briefly describes the NATTS main DQO and associated outputs and outcomes as related to the EPA's strategic goals. The workplan will prescribe the quantity of quality assurance samples (collocated, duplicate, or analysis replicate) to be collected at each site for the grant funding year. The workplan also specifies the required MDL MQOs for the Tier I Core analytes.

2.3 Quality System Development

There are 11 quality management specifications defined in EPA Order CIO 2105.0 (https://www.epa.gov/sites/production/files/2015-09/documents/epa_order_cio_21050.pdf) for all EPA organizations covered by the EPA Quality System. It is EPA policy that each agency conducting NATTS Program work must have a quality system that conforms to the minimum specifications of the American National Standards Institute (ANSI)/American Society for

Quality (ASQ) E4 “Specifications and Guidelines for Quality Systems for Environmental Data Collection and Environmental Technology Programs.”⁷ ASQ E4 is based on the general principle that the quality system provides guidelines for quality assurance (QA) and quality control (QC) based on the continuous cycle of planning, implementation, documenting, and assessment.⁸ Each agency’s quality system must also comply with the requirements as given in this TAD, which complements the requirements in ASQ E4. The purpose of defining the quality systems requirements in this manner is to provide a single source for developing or revising quality systems for NATTS Program work. Quality systems documents, including QAPPs and SOPs, must be revised to reflect the requirements. The quality system and associated functions are described in the plan-do-check-act feedback loop to ensure continuous improvement to ensure NATTS MQOs are met.

Plan - The planning portion of the quality system incorporates development of quality systems documents such as a QMP, QAPP, and SOPs which define the activities to be conducted, who they are conducted by, when activities are conducted, and how they must be documented. These documents must adapt and incorporate adjustments to procedures and policies when changes are needed or when procedures and policies become obsolete. Quality systems documents serve a dual purpose in that they describe how activities will be conducted and serve to document policies and procedures for reconstructing past activities.

Do - Activities described in the quality systems documents must be implemented and executed as prescribed. Staff training is a necessary element of a functional quality system, ensuring that each individual conducting activities has the experience and skills required to generate work product of a known and adequate quality. Appropriate training combined with up-to-date quality systems documents ensure that staff have both the skills and procedures to conduct activities as required.

Check - Assessments are conducted during and after planning and implementation to ensure that work products meet the objectives and needs of the program as defined during planning. Additionally, assessments ensure that quality systems documents sufficiently describe the activities to be performed, that measurements and calculations are accurate, that staff perform activities per the current quality systems documents, that staff training is up to date, and that nonconformances are communicated to those ultimately responsible for the program.

Act - Following assessments, root cause analysis is performed and corrective action is taken to address nonconformances such that the NATTS program may be continuously improved.

Each agency must have a robust and fully-functioning quality system to ensure that NATTS Program MQOs for the various DQIs are met. When MQOs are met across the entire network, the NATTS program DQO will be attained. A fundamental part of a functional quality system is the QAPP, which each agency must develop and maintain for NATTS program work. Details and specific quality system elements that must be incorporated in the NATTS QAPP are presented in Section 3.

2.4 Siting Considerations

Urban concentration data are needed to address the range of population exposures across and within urban areas. Conversely, rural concentration data are needed for characterization of exposures of non-urban populations, to establish non-source impacted concentrations (as practicable), and to better assess environmental impacts of emissions of air toxics. The NATTS network at the time of this TAD revision consists of 20 urban sites and seven rural sites. Each of these sites has been established since 2008, and only modest modifications involving relocation within a small geographic area have occurred over the past several years. Long-term monitoring needed to measure average concentrations over successive three-year periods requires that sites are maintained at, or in very close proximity to, their current location. This long-term data generation from each site is integral to discerning trends in air toxics concentrations.

For each of the 27 sites currently in the NATTS network, sampling unit siting may have changed little, if at all, from when sample collection for the NATTS Program began at the specific site. Nonetheless, site operators should evaluate instrument siting annually to ensure that requirements continue to be met consistently across the network. Siting criteria to consider relate to changes at the site such as tree growth, construction or development on property near the site, new sources, and other changes which may impact sample collection and the resulting measured concentrations. Particular attention should be paid to vertical placement of inlets, spacing between sampling inlets, proximity to vehicle traffic (especially where traffic levels have increased due to housing or business development), and proximity to obstructions or other interferences. Additionally, monitoring agencies should be aware of changes in sources, population, and neighborhood make-up (businesses, industry, etc.) which may impact sampler siting or sample concentrations.

Monitoring unit inlet placement must conform to the specifications listed in 40 CFR Part 58 Appendix E and the additional guidance given below.

2.4.1 Sampling Instrument Spacing. Requirements for sampler spacing are relative to the sampling unit inlet (edge) and must conform to the criteria listed in Table 2.4-1.

As an example, per the table above, an inlet to a carbonyls sampler must be no less than 2 m and no more than 15 m above the ground and it may be no closer than 2 m to any high volume sampler. Moreover, the inlets of collocated samplers may be no further than 4 m in the horizontal direction, and no more than 3 m apart vertically.

Note that for gaseous HAPs (VOCs and carbonyls) there is no minimum collocation distance as gases are much more homogeneous in the ambient air than particulate matter, and are not likely to influence one another, particularly at the low flow rates utilized.

Table 2.4-1. Sampling Unit Inlet Vertical Spacing Requirements

Parameter	Flow Rate	Inlet Above Ground Level Height Requirement ^a	Horizontal Collocation Requirement	Vertical Collocation Requirement
VOCs	Low volume (< 1000 mL/min)	2-15 m	0-4 m	≤ 3 m
Carbonyls	Low volume (~ 1 L/min)	2-15 m	0-4 m	≤ 3 m
PM ₁₀ Metals	Low volume (~16.7 L/min)	2-15 m	1-4 m ^b	≤ 3 m
	High volume ^c (~ 1.1 m ³ /min)	2-15 m	2-4 m ^b	≤ 3 m
PAHs	High volume ^{c, d} (> 0.139 m ³ /min)	2-15 m	2-4 m	≤ 3 m

^a Many standalone sampling unit inlets do not meet the minimum height and must be installed on a support structure such as a riser or rooftop to elevate the inlet to the proper height.

^b 40 CFR Part 58 Appendix A Section 3.3.4.2(c).

^c These high volume sampling units must be minimally 2 m from all other sampling inlets.

^d 40 CFR Part 58 Appendix E states that high volume sampling units are those with flow > 200 L/minute. However the regulations are silent on high volume PAHs sampling units, which operate > 139 L/minute; in this TAD they are conservatively being treated as high volume sampling units such that they must minimally be 2 m horizontally from other instrument inlets.

2.4.2 Interferences to Sampling Unit Siting. Interference from other samplers, particularly high volume sampling units for PAHs and PM₁₀ metals, must be avoided by ensuring that all inlets are minimally 2 meters from any high volume inlet. Additionally, to eliminate recollection of already sampled “scrubbed” air, exhausts (when so equipped) from high volume sampling units must be directed away from air samplers in the primary downwind direction via hose that terminates minimally 3 meters in distance from any sampler.

PM₁₀ metal sampling unit sites must not be in an unpaved area unless covered by vegetation year round, so the impacts of wind-blown dusts are kept to a minimum.⁹

Tarred or asphalt roofs should be avoided for the install of inlets for carbonyls, VOCs, and PAHs air samplers as these materials may emit target analytes during warmer sampling periods. If installation is performed on such a roof, it is recommended that the tar or asphalt be encapsulated or sufficiently weathered and that collected samples be evaluated for marker compounds indicative of contamination or influence from the tar or asphalt.

2.4.3 Obstructions. An inlet of standalone sampling units and inlet probes must be at least 1 meter vertically or horizontally away from any supporting structure, wall, parapet, or other obstruction. If the probe is located near the side of a building, it should be located on the windward side relative to the prevailing wind direction during the season of highest concentration potential.

Inlets must have unrestricted airflow and be located away from obstacles so that the distance from the obstacle to the inlet is at least twice the height difference the obstacle protrudes above the inlet. For instance, if a monitoring trailer is 4 meters above the inlet of a PM₁₀ metals sampling unit, the inlet must be minimally 8 meters from the monitoring trailer.

All sampling inlets must be minimally 10 meters from the dripline (end of the nearest branch) of any tree.

2.4.4 Spacing from Roadways. Sampling unit inlets for VOCs, carbonyls, PM₁₀ metals, and PAHs must meet or exceed the minimum distance from roadways according to Table 2.4-2.

Table 2.4-2. Sampling Unit Inlet Required Minimum Distances from Roadways

Roadway Average Daily Traffic (ADT), Vehicles per Day	Minimum Distance to Inlet (m) ^a
≤ 15,000	15
20,000	20
40,000	40
60,000	60
80,000	80
≥ 100,000	100

^a Distance from the edge of the nearest traffic lane. The distance for intermediate traffic counts should be interpolated from the table values based on measured traffic counts. Values in this table taken from 40 CFR Part 58 Appendix E, Figure E-1 for neighborhood scale sites.

2.4.5 Ongoing Siting Considerations. Agencies must be mindful of conditions at the site that may impact siting criteria.

Infrequent, non-characteristic, or non-representative sources such as road and building construction may impact measured sample concentrations due to increased dust, emissions from materials utilized (paints, paint strippers, asphalt, etc.), and heavy machinery operation. Other such sources include demolition operations (e.g. buildings or roadways) generating dust which may impact PM₁₀ metals concentrations. Application of fresh pavement and painting of traffic lanes generates substantial concentrations of PAHs and VOCs. For sites in residential areas, storage of fuels, operation of charcoal grills, backyard fire pits, and fireplaces can contribute to elevated measured concentrations of PAHs and PM. Concentrations of HAPs measured at rural sites may be affected by forest fires, logging operations, etc. Observation of such conditions must be noted on the sample collection records or site log and may require qualification of results.

Fast growing trees, newly constructed buildings or traffic routes, and other interferences must be noted and recorded in the site log and data must be qualified, as appropriate. When these items negatively impact the siting criteria, the obstruction or interference must be addressed. Such necessary changes to instrument siting should be included in each site's annual network plan. For unavoidable impacts to the site (such as a business acting as a significant source), these should be addressed in the network plan and may require relocation of the site. Such interferences and potential relocation should be discussed and addressed in concert with the EPA Region office.

2.5 References

1. *Quality Management Plan for the National Air Toxics Trends Stations*. Quality Assurance Guidance Document, EPA 454/R-02-006. September 2005. Available at (accessed October 18, 2016): <https://www3.epa.gov/ttnamti1/files/ambient/airtox/nattsqmp.pdf>
2. Draft Report on Development of Data Quality Objectives (DQOs) for the National Ambient Air Toxics Trends Monitoring Network, September 27, 2002 (Appendix A of this TAD)
3. Analysis, Development, and Update of the National Air Toxics Trends Stations (NATTS) Network Program-Level Data Quality Objective (DQO) and Associated Method Quality Objectives (MQOs), Final Report, June 13, 2013. Available at (accessed October 18, 2016): <https://www3.epa.gov/ttnamti1/files/ambient/airtox/nattsdqo20130613.pdf>
4. *National Air Toxics Program: The Integrated Urban Strategy*, Report to Congress, EPA 453/R-99-007, July 2000. Available at (accessed October 18, 2016): <https://www.epa.gov/sites/production/files/2014-08/documents/072000-urban-air-toxics-report-congress.pdf>
5. *National Air Toxics Trends Stations Quality Assurance Annual Report, Calendar Years 2011 and 2012, Final*, December 12, 2014. Available at (accessed October 18, 2016): <https://www3.epa.gov/ttnamti1/files/ambient/airtox/NATTS20112012QAARfinal.pdf>
6. *National Guidance for the Permitting, Monitoring, and Enforcement of Water Quality-based Effluent Limitations Set Below Analytical Detection/Quantitation Levels*, Draft Report. United States EPA, 1994
7. *Specifications and Guidelines for Quality Systems for Environmental Data Collection and Environmental Technology Programs*, American National Standards Institute (ANSI)/American Society for Quality (ASQ) E4, 2004.
8. *Overview of the EPA Quality System for Environmental Data and Technology*. EPA/240/R-02/003; U.S. Environmental Protection Agency: Office of Environmental Information. Washington, DC. November 2002. Available at (accessed October 18, 2016): <https://www.epa.gov/sites/production/files/2015-08/documents/overview-final.pdf>
9. Ambient Air Quality Surveillance, Probe and Monitoring Path Siting Criteria for Ambient Air Quality Monitoring, 40 CFR § 58 Appendix E, 201

3.0: QUALITY ASSURANCE AND QUALITY CONTROL

3.1 NATTS Quality Management Plan

EPA OAQPS developed the NATTS Program QMP to provide a set of minimum requirements that must be followed by all monitoring organizations (state, local, or tribal organization; or company) conducting NATTS Program work. Development of the QMP began in 2002 and was completed, approved, and implemented in 2005. Essential QA and QC elements are defined within the NATTS QMP¹ and are excerpted and presented in this document.

3.2 NATTS Main Data Quality Objective, Data Quality Indicators, and Measurement Quality Objectives

There is a single main DQO for the NATTS Program, which is stated as:

To be able to detect a 15% difference (trend) between two successive 3-year annual mean concentrations (rolling averages) within acceptable levels of decision error.

To achieve this primary DQO, the DQIs of representativeness, completeness, precision, bias, and sensitivity must meet specific MQOs, or acceptance criteria. The MQOs for each of the DQIs are as follows:

- **Representativeness:** Sampling must occur at one-in-six day frequency, from midnight to midnight local time, over 24 ± 1 hours
- **Completeness:** At least 85% of all data available in a given quarter must be reported
- **Precision:** The CV must be no more than 15%
- **Bias:** Measurement error must be no more than 25%
- **Sensitivity:** MDLs must meet the network requirements.

Each entity supporting NATTS Program data collection must ensure that these MQOs are met for each of the DQIs. Implementation of a robust quality system is part of the process to attain such.

3.3 Monitoring Organization QAPP Development and Approval

As discussed in Section 2.3, the monitoring organization quality system is the framework that ensures that defensible data of appropriate quality – those that meet the network MQOs for the various DQIs – are generated and reported to EPA so that the NATTS DQO is attained. The NATTS QAPP is the roadmap for design of each organization's quality system.

Given the importance of the QAPP, each monitoring organization operating a NATTS monitoring site and/or laboratory performing analysis of NATTS Program samples must have an up-to-date and fully approved QAPP which covers all aspects of the sample collection, analysis,

and QA/QC activities performed by the specific agency and at the associated laboratory at which samples are analyzed. All major stakeholders involved in the monitoring organization's and/or laboratory's NATTS Program work should provide input to and review the QAPP to ensure that aspects of the QAPP for which they are responsible are accurately and adequately described. The QAPP must minimally be approved and signed by the monitoring organization's NATTS Program Manager (however named) and the EPA Regional office (or EPA Regional office delegate as defined in the grant language) in which the monitoring site and/or laboratory exists and the QAPP must be on-file.

The NATTS QAPP must provide an overview of the work to be conducted, describe the need for and objectives of the measurements, and define the QA/QC activities to be applied to the project such that the monitoring objectives are attained. The QAPP should include information for staff responsible for project management, sample collection, laboratory analysis, QA, training, safety, data review, and data reporting.

The NATTS QAPP for each monitoring organization is the starting point or roadmap to ensure that the NATTS MQOs, and therefore NATTS monitoring objectives, are achieved. Review of the NATTS QAPP on an annual basis (or as required by the Region), conduct of audits and assessments, and implementation of effective corrective action ensure that NATTS sites and supporting labs are in fact achieving NATTS program objectives, and, if not, are implementing corrective actions, as needed.

The NATTS QAPP for each monitoring organization must include the NATTS DQO, DQIs, and MQOs listed above in Section 3.2, and should include elements listed in Section 3.3.1.3 to ensure that data of sufficient quality are generated over time such that concentration trends may be successfully detected and that monitoring data of comparable quality are generated across the entire NATTS network. The NATTS Program DQO, DQIs, and MQOs take precedent over regional, state, local, or tribal monitoring objectives for the associated air toxics sampling that is performed unless the SLT requirements are more stringent than those indicated for NATTS. Monitoring agencies are free to prescribe more conservative acceptance criteria (e.g. lower blank acceptance concentrations, tighter recovery ranges, etc.).

3.3.1 Development of the NATTS QAPP. EPA has developed a model QAPP as described in *EPA QA/R-5, EPA Requirements for Quality Assurance Project Plans*² and the accompanying document, *EPA QA/G-5, Guidance for Quality Assurance Project Plans*.³ This model QAPP may be a useful starting point in the development of the QAPP for each monitoring agency conducting NATTS Program work.

3.3.1.1 NATTS QAPP – Program DQOs, DQIs, and MQOs. The NATTS DQOs, DQIs, and MQOs, which are given in Section 3.2 of this TAD, must be included in the NATTS QAPP.

3.3.1.2 NATTS QAPP – Performance Based Method Criteria. NATTS Program work must comply with the requirements listed in this TAD and with the collection and analysis methods specified in Section 4. Acceptance criteria specified in the methods must be met as prescribed; however, method deviations are permitted provided the acceptance criteria for precision and bias are met and can be demonstrated to be scientifically sound and defensible. The NATTS Program

is designed according to the EPA's Flexible Approaches to Environmental Measurement (FAEM). The FAEM is a performance-based measurement systems approach which prescribes specific methods or approaches to be implemented, but permits deviations in the manner in which the specified methods are performed provided that the resulting data meet the data quality acceptance criteria for precision and bias.

Planned method deviations must be described in the monitoring organization's QAPP and must be approved by the cognizant EPA regional office (or delegate as detailed in the grant language). Adjustments to storage conditions and holding times are not permitted, nor are deviations which permit exceedances to the specified method acceptance criteria or to NATTS MQOs as such would allow data of a quality lower than, and not comparable to, that required to be generated in the NATTS network per the NATTS QMP and per this TAD. Agency QAPPs should incorporate much of the guidance listed in this TAD.

3.3.1.3 NATTS QAPP – Incorporating Quality System Elements. In addition to the example information contained in the model QAPP listed in Section 3.3.1, monitoring organizations should develop and prescribe within the QAPP the following quality system elements which are described in more detail in the following sections:

- Pertinent SOP documents
- Corrective action procedures
- QA unit and internal audit procedures
- Calibration of instruments
- Document control
- Training requirements and documentation, and demonstration of capability
- Sample custody and storage
- Traceability of reagents and standard materials
- Labeling
- Early warning systems – control charts
- Spreadsheets and data reduction algorithms
- Software validation, updating, and upgrading
- Review of records
- Data verification and validation
- Reporting of results to AQS
- Records retention and archival
- Safety

3.3.1.3.1 Standard Operating Procedure Documents. The NATTS QAPP must list the pertinent SOPs, however named, to be followed to conduct all NATTS Program work. SOPs must prescribe the details of the activities applicable to sample collection in the field, preparation and analysis of the samples in the laboratory, and data review, reduction, and reporting. SOPs must minimally cover the following aspects of the NATTS program:

- Sample collection for VOCs, carbonyls, PM₁₀ metals, and PAHs;
- Sample preparation and analysis for VOCs, carbonyls, PM₁₀ metals, and PAHs;

- Calibration, certification, and maintenance of each type of sample collection and analysis instrument;
- Calibration of critical support equipment; and
- Data review.

Additional SOPs should be prepared as necessary to cover routine procedures and repetitive tasks which, if performed incorrectly, could affect data quality such as COC and performing numerical calculations (describing rounding, significant figures, etc.).

Refer to Section 3.3.2 for further guidance on preparation of SOPs.

For portions of the sample collection and analysis which are contracted or otherwise performed elsewhere (not by the cognizant NATTS monitoring agency), the monitoring organization must reference the SOP of the third party in its NATTS QAPP and if the laboratory is other than the national contract laboratory (which are maintained by EPA), must maintain a current, approved copy of the third party's SOP(s) on file. Monitoring agencies must ensure that third-party laboratory QAPPs and SOPs are available.

3.3.1.3.2 Corrective Action Process. Each monitoring organization must have a corrective action process in place that is executed upon discovery of nonconformances to the NATTS TAD, NATTS agency QAPP, and/or applicable agency SOPs. Each monitoring organization should ideally have a corrective action tracking procedure so that all corrective actions are available in a single location (e.g., binder, database, etc.) and may be readily referenced. Corrective actions are taken to remedy nonconformances found during audits or assessments; however, corrective action must also be performed and documented for nonconformances or problems noted during routine, everyday operations.

For each nonconformance, a corrective action report should be prepared which includes the following components:

- Unique corrective action report (CAR) identifier
- Identification of the individual initiating the CAR (staff person's name)
- Date of discovery of nonconformance
- Date of CAR initiation
- Area or procedure affected (e.g., PM₁₀ metals sample collection)
- Description of the nonconformance (what happened and how it does not conform)
- Investigation of the nonconformance (how discovered, what is affected by the nonconforming work)
- Root cause analysis (what caused the nonconformance)
- Investigation for similar areas of nonconformance

- Immediate and long-term (if needed) remedial corrective actions (and documentation of when completed)
- Due date for remedial action completion
- Impact assessment of nonconformance
- Assessment of corrective action effectiveness
- Demonstration of return to conformance
- Follow up audit to ensure corrective actions were effective (with date completed)

Situations which would require a corrective action report include, but are not limited to:

- Repeated calibration failure
- Incorrect sample storage conditions
- Blank contamination
- Incorrect procedures followed
- Repeated QC acceptance criteria failures

Root cause analysis should be performed as soon as possible so remedial actions may be taken to correct the problem before it affects other procedural areas or additional samples and to minimize recurrence of the problem. For problems where the root cause is not immediately obvious, a stepwise approach should be taken to isolate the specific cause(s) of the nonconformance(s). Incorrect conclusions may result if too many variables are altered at one time, rendering the corrective action process ineffective.

An example CAR form is shown below in Figure 3.1-1.

Corrective Action Report

Corrective Action Report ID (CAR-YYYYMMDD-XXX):	
Initiated By:	
Area(s) or Procedure(s) Affected:	
Description of Nonconformance:	
Investigation of Nonconformance:	
Root Cause:	
Investigation for Similar Instances of Nonconformance:	
Immediate Corrective Action(s):	Date(s) completed
Impact Assessment of Nonconformance:	
Long-term Corrective Action(s):	Date(s) completed
Assessment of Effectiveness of Corrective Action:	
Additional Corrective Action Necessary: (optional – Provide CAR ID)	Date(s) completed
Return To Conformance (if applicable):	Date(s) completed
Follow-up Actions (if any): Date(s) completed	
Corrective Action Completion Date:	
Approval of Corrective Action Completion	
QA Manager Representative:	

Figure 3.1-1. Example Corrective Action Report

3.3.1.3.3 Quality Assurance Unit and Internal Audit Procedures. Each monitoring organization should have a QA group, or, minimally, an individual quality assurance officer (however named). This quality assurance unit is typically responsible for performing assessments (audits) of sample collection procedures, sample analysis procedures, data records, and the quality system as well as managing and overseeing the corrective action process, managing document control, performing QA training, and reviewing QC data as applicable. Monitoring organizations which contract laboratory analysis should ensure that the laboratory operates a QA program to oversee and conduct audits of these aspects for which the laboratory is responsible.

QA staff should be independent from project management to best ensure that nonconformances are addressed and remedied and to maximize the likelihood that data of sufficient quality are generated. Moreover, independent QA oversight is integral to ensuring that internal audits are objective. For agencies which may not have sufficient resources to dedicate an independent QA staff member, an individual not affiliated with a given activity may serve to perform QA functions. The quality assurance staff should conduct three types of audits:

- **Technical systems audits (TSAs):** An onsite review and inspection of the monitoring agency's monitoring program to assess compliance with the established regulations governing the collection analysis, validation, and reporting of ambient air quality data.⁴ The auditor observes staff conducting sample collection and analysis activities and compares the activities performed against procedures codified in the agency QAPP and applicable SOPs, ensures proper documentation practices, verifies staff training records, verifies proper data reporting, and ensures all operations are performed in accordance with appropriate safety practices.
- **Audits of Data Quality (ADQs):** The auditor reviews reported data to ensure traceability of all measurements and calculations from initial receipt of sample collection media through to the final reported results. Calculations and data transformations are verified to be accurate.
- **Quality Systems Audits (QSAs):** The auditor reviews quality systems documents such as the agency QMP, QAPP, and SOPs to ensure they are current and to assess compliance with program requirements, such as those stipulated in this TAD.

The monitoring organization QAPP, SOP, or other suitable controlled document should define the schedule for audit frequency, the scope of each type of audit (i.e., which operational areas must be observed, which records must be reviewed, etc.), the timeline for following up on audit nonconformances, the timeline for conducting follow-up audits that ensure that nonconformances are being remedied in a satisfactory and timely manner, and the method for reporting audit outcomes to agency management and staff. For monitoring organizations which utilize contract laboratory analysis services, the laboratory QAPP, QMP, or similar controlled document should define these frequencies.

3.3.1.3.4 Calibration of Instruments. Each agency must define in the NATTS QAPP, SOP, or similar controlled document the frequency at which critical instruments must be calibrated and the acceptable tolerance for such calibrations. Critical instruments are defined as those whose measurements directly impact the accuracy of the final reported concentrations. The calibration of such instruments must be traceable to a certified standard and a standard calibration process. Critical instruments include, but are not limited to:

- Flow transfer standards
- Mass flow controllers, mechanical flow controllers, and meters generating flow readings for calculating total collected sample volumes and diluting standard gases
- Thermometers and barometers

- Volumetric delivery devices such as fixed and adjustable pipettes, bottletop dispensers, etc.
- Balances
- Pressure gauges and transducers when measuring pressures for dilution or standard preparation

Such critical instruments must be calibrated initially and the calibration verified (checked) periodically to ensure the calibration remains valid. Instruments must be recalibrated (or removed from service and replaced with a properly calibrated unit) when calibration verifications fail. Data generated with the failing equipment since the last acceptable calibration or calibration verification must be examined and considered for qualification. Monitoring agencies are encouraged to perform more frequent calibration checks (identified as recommendations) to limit the amount of data subject to qualification when calibration checks fail acceptance criteria. Frequency of calibration verifications must conform to Table 3.3-1 and must be addressed within the agency NATTS QAPP, SOPs, or similar controlled document.

Table 3.3-1. Calibration and Calibration Check Frequency Requirements for Standards and Critical Instruments

Instrument or Standard	Area of Use	Required Calibration Check ^a Frequency and Tolerance	Required Calibration ^b Frequency
Balances	Laboratory – Weighing standard materials, calibration of pipettes, determining mass loss for microwave metals digestion, weighing PAHs sorbent resin (XAD-2)	Each day of use with certified calibration check weights bracketing the balance load; Must be within manufacturer-specified tolerance covering the range of use	Initially, annually, and when calibration checks demonstrate an out of tolerance condition
Certified Weights	Laboratory – Calibration verification of balances	Check not required.	Annual certification by accredited metrology laboratory; Must be within manufacturer-specified tolerance
Mechanical Pipettes	Laboratory – Dispensing liquid volumes	Minimally quarterly, recommended monthly, by weighing delivered volumes of deionized water bracketing those dispensed; Must be within manufacturer-specified tolerance covering the range of use	Initially and when calibration checks demonstrate an out of tolerance condition
Bottletop Dispensers	Laboratory – Dispensing critical liquid volumes	Each day of use by delivery into a To Contain (TC) graduated cylinder Must be within $\pm 5\%$	When delivery volumes are set and when calibration checks fail criteria
Thermometers – Laboratory	Laboratory – Temperature monitoring of water baths, metals digestion, refrigerated storage units, canister cleaning ovens, and water for pipette calibration	Check not required.	Annual at temperature range of use or at not-to-exceed temperature – Correction factors applied to match certified standard

Table 3.3-1. Calibration and Calibration Check Frequency Requirements for Standards and Critical Instruments (Continued)

Instrument or Standard	Area of Use	Required Calibration Check ^a Frequency and Tolerance	Required Calibration ^b Frequency
Thermometers – Meteorological	Field – Recording environmental conditions during sample collection	Minimally quarterly, monthly recommended Must be within $\pm 0.5^{\circ}\text{C}$ of certified standard at working temperature	Initially and when calibration checks indicate readings out of tolerance
Barometers	Field – Recording environmental conditions during sample collection Laboratory – Recording environmental conditions during instrument calibration	Minimally quarterly, monthly recommended Must be within ± 10 mm Hg of certified standard at typical barometric pressure	Initially and when calibration checks indicate readings out of tolerance
Flow Transfer Standards	Field – Critical flow orifices and volumetric flow meters for calibrating and verifying sampling unit flows Built-in thermometers and barometers must be calibrated	Check not required.	Annual; Must be within manufacturer-specified tolerance and cover the range of use
Pressure Gauges or Transducers	Field and Laboratory – Measure canister pressure/vacuum before and after collection, measure final canister vacuum following cleaning	Annual. Must be within 0.5 psi or manufacturer-specified tolerance and cover the range of use	Initially and when calibration checks show out of tolerance. Must cover the range of use
Flow Controllers and Meters – Laboratory	Laboratory – Mass flow controllers (MFCs), flow rotameters, or similar devices for measuring/metering gas flow rates for critical measurements (standard gas mixing)	Minimally quarterly, monthly recommended Flow within $\pm 2\%$ of certified standards	Initially and when calibration checks demonstrate flows are out of tolerance
VOCs Sampling Units	Field – Collection of VOCs in canisters Flow control (such as MFC) Pressure gauge/transducer	If performed, minimally quarterly, for flow control, annually for pressure gauge/transducer Flow control (check is optional) within $\pm 10\%$ of certified flow If needed for critical measurements (canister starting/ending pressure), pressure gauge/transducer within ± 0.5 pounds per square inch (psi) of certified standard	Flow control - Initially and when components affecting flow are adjusted or replaced, or when calibration checks demonstrate flows are out of tolerance Pressure gauges/transducers – initially and when calibration checks demonstrate flows are out of tolerance
Carbonyls Sampling Units	Field – Collection of carbonyls on 2,4-dinitrophenylhydrazine (DNPH) sorbent cartridges Flow control (such as MFC)	Minimally quarterly, monthly recommended Flow within $\pm 10\%$ of certified flow and design flow	Initially, when calibration checks demonstrate flows are out of tolerance, and when components affecting flow are adjusted or replaced

Table 3.3-1. Calibration and Calibration Check Frequency Requirements for Standards and Critical Instruments (Continued)

Instrument or Standard	Area of Use	Required Calibration Check ^a Frequency and Tolerance	Required Calibration ^b Frequency
PM ₁₀ Metals Sampling Units	Field – Collection of PM ₁₀ on filter media for metals analysis Flow control must be within tolerance If equipped, thermometer and barometer must be within field tolerances specified above	Minimally quarterly, monthly recommended Low volume flows within ±4% of transfer standard and ±5% of design flow High volume flows within ±7% of transfer standard and ±10% of design flow	Initially, when calibration checks demonstrate flows are out of tolerance, and when components affecting flow are adjusted or replaced
PAHs Sampling Units	Field – Collection of carbonyls on QFF, PUF, and XAD-2 media sampling modules Flow control must be within tolerance If equipped, thermometer and barometer must be within field tolerance specified above	Minimally quarterly, monthly recommended Flow within ±10% of certified flow and design flow	Initially, when calibration checks demonstrate flows are out of tolerance, and when components affecting flow are adjusted or replaced
GC/MS for VOCs analysis	Laboratory – Analysis of VOCs from stainless steel canisters	Refer to Table 4.2-3	Initially, following failed continuing calibration verification (CCV) check, following failed bromofluorobenzene (BFB) tune check, or when changes/maintenance to the instrument affect calibration response
HPLC for carbonyls analysis	Laboratory – Analysis of carbonyl-DNPH extracts	Refer to Table 4.3-4	Initially, following failed continuing calibration verification (CCV) check, or when changes/maintenance to the instrument affect calibration response
ICP/MS for metals analysis	Laboratory – Analysis of PM ₁₀ digestates for metals	Refer to Table 4.4-3	Each day of analysis
GC/MS for PAHs analysis	Laboratory – Analysis of polyurethane foam (PUF)/resin/quartz fiber filter (QFF) extracts for PAHs	Refer to Table 4.5-3	Initially, following failed continuing calibration verification (CCV) check, following failed decafluorotriphenylphosphine (DFTPP) tune check, or when changes/maintenance to the instrument affect calibration response

^a Calibration verification checks are a comparison to a certified standard, typically at a single point at which the instrument is used, to ensure the instrument or standard remains within a prescribed tolerance. Instruments or standards which exceed the tolerance must be adjusted to be within prescribed tolerances or replaced.

^b Calibration refers to resetting the reading or setting or applying a correction factor to the instrument or standard to match a certified standard, typically at three or more points bracketing the range of use.

3.3.1.3.4.1 Calibration Verification (Checks)

Following instrument calibration, critical instruments must undergo periodic calibration verification (check) to ensure bias meets the assigned acceptance criterion. Calibration checks typically challenge the instrument at a single point typical of use or toward the middle of the calibration range. Calibration checks may also include multiple points bracketing the range of use. Instruments for which calibration checks are required include, but are not limited to:

- Mass flow controllers, mechanical flow controllers, and meters generating flow readings for calculating total collected sample volumes and diluting standard gases
- Volumetric delivery devices such as fixed and adjustable pipettes, bottletop dispensers, etc.
- Balances
- Analytical instruments generating concentration data (e.g. GC/MS, HPLC, ICP-MS)

3.3.1.3.5 Document Control System. Each monitoring organization must have a prescribed system defined in its NATTS QAPP or QMP for control of quality system documents such as QMPs, QAPPs, and SOPs. A properly operating document control system ensures that all documents integral in defining performance criteria and prescribing procedures are current, and that outdated or superseded documents are not available for inadvertent reference. All such controlled documents must minimally be approved by a cognizant manager (however named) who is ultimately responsible for the conduct of the work (e.g., monitoring agency director for an agency QMP, NATTS program manager for the NATTS QAPP, monitoring manager or laboratory manager for a field or analytical SOP, etc.), and by a QA staff member responsible for overseeing the work. Current versions of controlled documents must be readily available to each staff member conducting NATTS Program work.

To increase the likelihood that all applicable NATTS activities are performed according to current, approved procedures, the distribution of controlled documents should be managed and tracked such that only the current, approved versions are available in areas in which such documents are needed (for example, at field sites and in laboratories) and that outdated versions are removed once superseded. With the proliferation of networked computers at monitoring sites and within laboratories, it is convenient to have electronic versions of controlled documents available which are write-protected. Printing privileges of such read-only electronic documents should be disallowed, or, if printing is permitted, such documents should be identified via watermark with the date of printing and their expiration.

Procedures and frequency for changing and updating controlled documents should be clearly described in the QAPP, SOP, or similar controlled document. Preparing amendments is an efficient way to address minor changes to controlled documents. An amendment describes the change and rationale for the change, and may be appended to the document without requiring a complete revision of the document. Such amendments should be approved minimally by the cognizant manager (field operations manager or laboratory manager) responsible for the conduct of the work, and by a member of QA staff responsible for the document and overseeing the

work. For major changes to controlled documents, such as those required for a new sampling unit or updated laboratory information management system (LIMS), a new revision should be prepared and approved by all required signatories. A system for identifying revisions should be prescribed to allow tracking of versions. A typical example system uses whole numbers to designate major revisions and decimals to indicate minor revisions. For example, the first version of a QAPP would be version 1.0, a minor revision would update to version 1.1, and the next major revision would be version 2.0, and so on.

An effective date must be included on all controlled documents and they should include an issue date if this is different from the effective date. A period between the issue date and effective date permits staff to become familiar with the SOP prior to its becoming effective. A header or footer should indicate the effective date, version number, page number, and total number of pages included in the document. A best practice is to include a revision history section for each controlled document so that readers can quickly and efficiently ascertain changes from the previous version of the document.

Monitoring agencies (and laboratories) should forbid uncontrolled excerpts to be printed from controlled documents such as operation instructions or calibration standard preparation tables. These excerpts are then uncontrolled and may inadvertently be referenced when the version of origin is no longer effective. For the same reason, unless permitted by the agency's controlled document policy, uncontrolled shortcut procedural summary documents (summarizing SOP procedures) similarly should not be permitted. Such procedure summaries may be included in the NATTS QAPP or applicable SOP to ensure they are updated when the document is revised. Similarly, notes should not be recorded on controlled document hard copies unless permitted by the monitoring organization's controlled document revision or amendment process.

The review frequency for controlled documents should be described within the QMP, QAPP, or similar controlled document. Periodic review of controlled documents must be performed to ensure that they adequately describe current agency policies and procedures. Each such review and outcome of the review (e.g., adequate, minor revision needed, major revision needed, etc.) should be documented. The agency NATTS QAPP must be reviewed annually and associated SOPs are recommended to be reviewed annually, but must minimally be reviewed every three years. SOPs must be reviewed following major changes to network guidance to ensure they are compliant with the updated guidance.

3.3.1.3.6 Training Requirements and Documentation, and Demonstration of Capability. The training required for each staff member who conducts NATTS Program work must be prescribed in the agency NATTS QAPP, SOP, or similar controlled document, and the completion of each required training element must be documented. Specifically, staff must read, and document that they have read and understood, the most recent versions of the NATTS quality system documents (QAPP, SOPs, etc.) pertaining to their responsibilities.

Each monitoring organization must have minimum requirements for staff position experience including a combination of education and previous employment experience. In addition to documented experience, each staff member must be approved by cognizant management to conduct the activities for which they are responsible. Such approval should be granted initially

before beginning work and periodically thereafter, and should be minimally based on successful completion of a demonstration of capability (DOC) process. DOCs are described in the subsections below.

Each staff member must have training documented which indicates the staff member's training is current for each procedure performed, as required by the agency QMP, NATTS QAPP, SOP, or similar controlled document. Training documentation can consist of hard copy or electronic documentation and may be located in numerous files or locations, provided it can be retrieved for auditing purposes. In addition to relevant DOC documentation, the training records should include items related to experience such as a resume or curriculum vitae, certificates from training coursework, and a job description specific to the monitoring organization.

3.3.1.3.6.1 Initial Demonstration of Capability

Once the staff member has read the relevant current SOP, and documented such, the staff member must demonstrate proficiency with a given procedure prior to performing activities to generate or manipulate NATTS program data. One method by which such could be accomplished is as follows. First, the staff member observes an experienced staff member performing the procedure. Next, the trainee conducts the activity under the immediate supervision of and with direction from an experienced staff member. Finally, the trainee performs the activity independently while being observed by an experienced staff member. To ensure all aspects of a procedure are captured in the initial DOC, it is recommended that a checklist be developed that includes all required steps consistent with the applicable quality system document(s) to perform the activity. Regardless of the actual initial DOC process selected for implementation, the process to be implemented and its acceptance criteria must be defined in the QAPP, SOP, or similar controlled document.

3.3.1.3.6.2 Ongoing Demonstration of Capability

Each staff member performing NATTS Program field work must demonstrate continued proficiency with tasks for which they are responsible, minimally every three years, but recommended to be annually. The staff member should be observed by a QA staff member (as part of an audit), experienced staff member, or responsible manager.

Laboratory staff must annually demonstrate continued proficiency by completing one of the following:

- Repeat of the IDOC procedure.
- Acceptable performance on one or more blind samples (single blind to the analyst) following the approved method for each target analyte. Acceptable performance is indicated by demonstrating recovery within limits of the method LCS for each target analyte.
- Analysis of at least four consecutive LCSs with acceptable levels of bias. Acceptable performance is indicated by demonstrating recovery within limits of the method LCS for each target analyte.

- Acceptable performance on a PT sample. Acceptable performance is defined by the provider of the PT sample, as indicated by no results marked as “Unacceptable” or equivalent, for target analytes.

As with the initial demonstration of capability, the continuing DOC process and its applicable process acceptance criteria must be prescribed in the agency NATTS QAPP, SOP, or similar controlled document.

3.3.1.3.7 Sample Custody and Storage. Procedures and details related to sample custody and sample storage must be included in each monitoring organization’s NATTS QAPP or similar document such as a sample handling SOP.

The COC is a documented trail of who had possession of a sample or group of samples at any specific point from collection through receipt at the laboratory. Custody records must include details of transfers of possession between individuals, between individuals and shippers (when applicable), and to storage at the laboratory and any pertinent details such as storage location and conditions. It is strongly recommended to maintain sample integrity that samples be protected and access to the samples be limited to those responsible for the samples.

Sample custody begins when media are readied for dispatch to the field monitoring site. At this point, a COC form, sample collection form with portions dedicated to documenting custody transfers, or other form as defined by the monitoring agency, must accompany the sampling media until they are received at the laboratory for analysis. Each time the sampling media are transferred, the individual relinquishing the sample and receiving the sample, the date and time, and the storage conditions (for carbonyls and PAHs samples) should be documented so the history of the sample is traceable and can be reconstructed. Storage conditions for carbonyls and PAHs samples must be monitored with a calibrated thermometer and storage records should include unique identifiers for the thermometers monitoring the storage units.

Sample collection forms or other forms as defined by the monitoring agency may double as a COC form provided they include sufficient space for documenting all sample transfers and storage conditions.

If not already assigned prior to dispatching to the field, upon receipt at the laboratory each specific field-collected sample medium (cartridge, filter, canister, etc. including all field QC) must be uniquely identified for tracking within the laboratory. This unique identifier allows each sample to be tracked to ensure proper storage within the laboratory and to avoid switching of samples which can invalidate sample data.

3.3.1.3.8 Traceability of Reagents and Standard Materials. Each monitoring organization must prescribe in its NATTS QAPP, or similar controlled document, the information to be recorded and maintained for traceability of reagents and standard materials and must codify the requirements for their labeling.

All reagents and standard materials utilized in the preparation and analysis of NATTS Program samples must be of known concentration or purity as documented by a certificate of analysis

(COA) or similar certification. Such certification documents must be retained. The one exception to this is for deionized water which is sourced from a water polisher, for which records of the maintenance must be maintained to demonstrate that the water is of appropriate quality. When prepared in the laboratory, the source of all reagents must be documented (in a logbook or similar) and be traceable to the certificates of analysis. Lot or batch numbers for each reagent (acid, solvent, etc.) must be documented for all preparations. Critical volume measurements (e.g. delivered volumes of stock standards, final volumes of diluted standards) must be documented in the preparation log when used for reagent or standard preparation, including unique identifiers (where applicable) for measurements by way of volumetric syringes, mechanical pipettes, and volumetric flasks, among other methods. The conditions at which the reagents and standards are stored must be documented, particularly for those reagents and standards which require special conditions such as refrigeration or protection from light. If maintenance of a specific temperature range or not-to-exceed temperature is required, the temperature(s) of storage container(s) must be measured and documented at a prescribed frequency (recommend minimally daily during normal working hours) and the calibration of thermometers must be certified and traceable at the critical temperature (e.g. for a carbonyls sample storage refrigerator, the thermometer must be calibrated at 4°C). A calibrated min-max type thermometer or continuous monitoring is recommended to ensure that the not-to-exceed temperature is maintained.

Expiration dates must be assigned to reagents and standards and must be set as the earliest expiration date among any component comprising the reagent or standard. If the expiration date is given as a month and year, the date after which the reagent or standard may not be used is understood to be the last day of the indicated month. For reagents or standards which were not assigned an expiration by the supplier, the monitoring agency may assign an expiration (recommended not to exceed five years). The policy for assigning the expiration date when not provided by the manufacturer must be prescribed in the monitoring agency QAPP, SOP, or similar controlled document.

3.3.1.3.9 Labeling. Each NATTS monitoring organization must have a prescribed procedure for labeling of all samples, standards, and reagents. Each must be uniquely identified and the identifier clearly labeled on the applicable container (e.g., VOCs canister tag, DNPH cartridge foil pouch, metals filter holder, PAHs cartridge transport jar, GC vial containing solvent, etc.).

Standards and reagents must be minimally labeled to identify the contents (e.g., 69-component VOC blend in nitrogen, 2 µg/mL benzo(a)pyrene in hexane, 2% v/v nitric acid, etc.), and should include the preparation date and expiration date. All standards and reagents prepared or mixed in the laboratory must be traceable to a preparation log.

3.3.1.3.10 Early Warning Systems – Control Charts. Laboratories should employ control charting where practical to track QC parameters. If used, the process of control charting should be described in the NATTS QAPP, SOP, or similar controlled document. Parameters suitable for control charting include concentrations measured in QC samples such as blanks, laboratory control spikes, matrix spikes, secondary source calibration standards, internal standards, and proficiency test results. Control charts may be prepared with spreadsheets and

many LIMS incorporate control charting capabilities. Once implemented, control charts are simple to maintain and are a valuable tool for evaluating trends and may provide an alert before nonconformances occur. Control charts should be periodically updated and reviewed to ensure data inputs are current and that associated control limits meet method-specified criteria. The update frequency should be prescribed in the applicable controlled document.

3.3.1.3.11 Spreadsheets and Other Data Reduction Algorithms. While spreadsheets and other automated or semi-automated data reduction algorithms, for instance, those contained in LIMS software, are valuable tools for transforming and reducing data generated by sampling and analysis instruments, they have limitations and may be sources of error. If a NATTS agency in fact employs such processes it should prescribe the NATTS QAPP, SOP, or similar controlled document the details for preparation, review, and control of data reduction spreadsheets or of other non-commercial automated and/or semi-automated data transformation and reduction algorithms and processes. Implementation of such processes will require an initial time investment, but should minimize errors and subsequently increase the efficiency and speed of data reporting. If an agency were to implement such processes, it should codify the relevant procedures into its QAPP or other quality system document and may consider adoption of the following best practices.

Where possible, manual entry of instrument data into spreadsheets and/or non-commercial automated data transformation/reduction algorithms must be minimized. Rather, the direct importation of data outputs from instruments into such systems is preferable so as to avoid transcription errors. Furthermore, data reduction spreadsheets or other non-commercial algorithms must be validated and locked/non-editable to ensure that critical formulas are not inadvertently altered. The process of validation of the spreadsheet or non-commercial algorithm must be codified in the quality system document such that it is known and verifiable that all critical aspects of the data reduction procedure have been confirmed to be technically defensible, valid, and error-free. This validation should be performed when the spreadsheet or non-commercial algorithm is revised.

3.3.1.3.12 Software Validation, Testing, Updating, and Upgrading. Each agency performing NATTS Program work should have prescribed within the agency NATTS QAPP, SOP, or similar controlled document policies and procedures for testing, updating, and upgrading computer software systems employed for data generation and manipulation such as chromatography data systems (CDSs), LIMS, and other instrument software where applicable. The policies and procedures should detail the responsible individuals, testing required, and documentation to be maintained.

3.3.1.3.12.1 Software Validation

Off-the-shelf software packages such as spreadsheet programs are presumed to be validated. It is strongly recommended that individual spreadsheets should be validated as described in Section 3.3.1.3.11. Other software packages such as CDS should undergo validation by manually calculating values to ensure that software outputs match the expected result. Due to the differences in algorithms or limitations to how software packages handle calculations, there may be slight differences between commercial software package outputs and spreadsheets or other

software systems. Such differences should be noted and addressed where possible if they impact digits which are significant in the calculations. Records of software validation must be maintained.

3.3.1.3.12.2 *Software Testing*

Once validated, software packages should be tested minimally annually and when updated or upgraded to ensure that calculations are being performed as expected. This may be performed by processing a previous dataset through the software and comparing the outputs for parity. The rationale behind such testing is to ensure that software systems and calculation regimes have not become corrupted. Discrepancies in outputs must result in corrective action to rectify the discrepancies.

3.3.1.3.12.3 *Software Updating and Upgrading*

Software manufacturers periodically release software updates to correct bugs, improve the user interface, or include new functionality, etc. Updates or upgrades installed should be documented in a log and be verified for proper operation by the testing regime prescribed in Section 3.3.1.3.12.2. Agencies should verify that upgrades were performed and the date they were performed.

3.3.1.3.13 *Review of Records.* To ensure that sample collection and analysis activities were performed as prescribed, are documented completely and accurately, and to identify potential nonconformances that may invalidate data, all logbooks, forms, notes, and data must be reviewed by a second individual who has familiarity with the procedure but who did not generate the record. Field site notebooks, site equipment maintenance logs, sample collection forms, COC forms, laboratory preparation logs, analysis instrument logs, storage temperature logs, and all other critical information must be reviewed on a periodic basis by an individual who did not record the documentation. Each record should minimally be reviewed for legibility, completeness, traceability, and accuracy (including hand calculations not performed by a validated spreadsheet). It is also recommended that reviews should determine if the procedures followed were codified and appropriate. These reviews must be documented, either within the records themselves, or in a separate review notebook or form indicating the individual performing the review, the materials reviewed, and when the review was performed. Details of the review scope, schedule, responsible individuals, and required documentation must be described in the NATTS QAPP, SOP, or similar controlled document. These reviews should occur minimally quarterly and a best practice would be to conduct reviews monthly.

If documentation errors are noted during review, they should be corrected as soon as practical. Correction of handwritten entries must be performed with a single line, the correct entry must be made nearby or be traceable to an annotated footnote, the individual making the correction must be identified by signature or initials, the notation must include the date the correction was made, and the notation should include the rationale for the correction. Corrections to electronic logs must likewise not overwrite the original record, must identify the individual making the correction, must include the date of the correction, and should include the rationale for the

correction. Further guidance on maintaining electronic logs is available in the EPA Technical Note - Use of Electronic Logbooks for Ambient Air Monitoring.⁵

Note that reviewing records as described in this section is a component of the data verification process described in the next section, but should not be substituted for the data verification process.

3.3.1.3.14 Data Verification and Validation. Data verification is the systematic process for evaluating objective evidence (data) for compliance with requirements for completeness and for correctness as stipulated by a specific method. Objective evidence consists of the records such as sample collection forms, sample storage records, laboratory preparation records, calibration records, analysis results, etc. Validation is the confirmation that verified data have met specific intended use requirements, i.e., meeting DQO requirements prescribed in the NATTS QAPP.⁶

Spurious data have an outsized influence on statistical analysis and modeling; thus, data must be closely examined to ensure that concentration values accurately reflect air quality conditions at the monitoring site through verification and validation. Monitoring organizations must not censor (invalidate) data they consider to be anomalous or spurious. Data should only be invalidated if they do not meet the critical specifications in the validation tables in Section 7 or when there is a known problem with the data which would invalidate them. For data suspected to be spurious or anomalous, they should be qualified appropriately when entered into AQS so the end data user can decide the most suitable manner for handling the data.

Each monitoring organization must have processes and policies which must be described within its NATTS QAPP or other quality systems document for data verification, data validation, and the associated documentation that is generated and retained during the processes of verification and validation of data. It is a best practice that NATTS agencies perform data verification in accordance with the tables in Section 7 of this TAD where method-specific criteria may be found. Additional information on implementing and structuring data validation and verification policies and procedures is available in *Guidance on Environmental Data Verification and Data Validation, EPA QA/G-8, EPA/240/R-02-004*.⁶

3.3.1.3.14.1 Data Verification

The data verification process begins when sample media are dispatched to the field for collection and ends following final review of a completed data package. Verification includes many of the aspects of data review discussed in Section 3.3.1.3.13 as well as additional QC checks such as verification of proper sample handling and verification of calculations. Once data verification is completed, data validation is conducted. Given in this section is a generic data verification process that a NATTS agency may adopt. Data verification is not required, but is *strongly recommended*.

Upon retrieval of samples in the field, the field operator verifies that sample collection parameters comply with SOPs and documents the collection details on the field sample collection form. At the laboratory, custody documentation is reviewed to ensure that sample

collection documentation meets specification and does not exhibit anomalies which would invalidate the collected sample. Laboratory analysts ensure that media have been stored properly and that QC samples are prepared according to method specifications. Following acquisition of the analytical data, the analyst reviews QC results as well as the acquired data to ensure proper analyte identification and to verify that method-specified acceptance criteria are met. A peer then reviews the entire data package beginning with sample collection and custody documentation through preparation, analysis, and concentration calculations so as to ensure that method procedures were properly followed, calculations are correct, and method-specific acceptance criteria are met. At any point during the initial and/or peer review, errors must be corrected and additional notes added to describe problems or anomalies in the sample collection and analysis processes. QC failures or method deviations must be documented and appropriate flags applied to the results so staff performing data validation may be alerted regarding data which may be compromised or require invalidation.

3.3.1.3.14.2 Data Validation

Data validation is performed following the data verification process and is a separate process from the network-wide assessments made by data users to evaluate trends and assess whether data meet MQOs. During validation data are evaluated by the monitoring agency for compliance with specific use requirements which may include comparison of collocated sample results, examination of meteorology data, sample collection notes, and custody forms, and review of historical data for trends analysis and identification of outlier data. Attainment of the NATTS MQOs should also be assessed by monitoring agencies to determine if the data will support attainment of the NATTS DQO. Failure to attain the NATTS MQOs must prompt corrective action. Given in the remainder of this section is a generic data validation process that a NATTS agency may adopt. Note that data are not being validated if the monitoring agency is not performing data validation since the EPA does not perform subsequent data validation.

An appropriate starting point for validating data involves preparing summary statistics by calculating the central tendency of the dataset along with the standard deviation and relative standard deviation of the concentrations of each HAP. The central tendency may be calculated as the arithmetic mean, geometric mean, median, or mode:

- Arithmetic mean: The sum of the measured concentration values divided by the total number of samples in the dataset.
- Geometric mean: The *n*th root of the product of *n* concentration values.
- Median: The concentration value represented by the midpoint of the dataset when the concentration values are placed in numerical order. Fifty percent of the resulting concentration values will be above this value and 50% will be below.
- Mode: The concentration value with the highest frequency.

Once the summary statistics have been prepared, each HAP and combination of HAPs may be evaluated using graphical techniques to identify anomalous data and outliers. Graphical techniques permit comparison of concentrations of each HAP to the expected concentrations and

relative concentrations of other HAPs to inspect for values which stand out. Time series plots, scatter plots, and fingerprint plots, described below, are valuable tools for validating data.

- Time series plots: Concentrations are plotted on the y-axis against collection date (time) on the x-axis. Extreme or anomalous values are immediately identifiable in individual HAP plots, and may be more powerful when multiple HAPs are plotted together. HAPs which are typically emitted from the same type of source (i.e., benzene and toluene from mobile sources) and from different sources (i.e., formaldehyde and PM₁₀ nickel) can provide insight on whether concentration anomalies are realistic to the collected sample or may be an artifact of the collection or analysis of the sample.
- Scatter plots: Concentrations of pairs of HAPs are plotted such that each HAP (e.g., benzene and toluene) is dedicated to the y-axis or x-axis such that the coordinates of each plotted point are set by the benzene and toluene concentrations measured during a given sampling event. The resulting plots generally show points which are clumped together such that they have a well-defined relationship. Points which lie outside of the well-defined area are then generally identifiable and can be further investigated.
- Fingerprint plots: Concentrations of all HAPs within a given class (e.g., VOCs, carbonyls, etc.) are plotted on the y-axis against the molecular weight, alphabetical order, or some other consistent order on the x-axis which enable discerning patterns or identifying anomalies. Fingerprints prepared for each sampling event are compared and will typically be very similar among events. Plots which show markedly different patterns may indicate anomalous results. For instance, during a specific sampling event a HAP may be observed at a concentration much higher or much lower than expected given the typically observed pattern between concentration and molecular weight (alphabetical order, etc.), and such is evidence of a spurious result for this HAP for this sampling event.

Confidence is increased for concentration data which do not appear anomalous when plotted using these graphical tools. For data which appear to be anomalous, they should be flagged for follow up and the root cause investigated.

The free Data Analysis and Reporting Tool (DART) software was developed with EPA funding and incorporates preparation of the graphical displays mentioned above. DART is available at airnowtech.org at the following URL: <http://airnowtech.org/dart/dartwelcome.cfm> (all users must have an account with username and password).

3.3.1.3.15 Reporting of Results to AQS. Each monitoring organization must prescribe procedures and policies for the reporting of all applicable information generated in the conduct of the NATTS Program to the EPA AQS database. AQS is a repository of data from state, local, and tribal agencies as well as federal organizations. The stored data consist of descriptions of monitoring sites and associated monitoring equipment, reported concentrations of air pollutants, data flags, and calculated summary and statistical information.

This section discusses reporting of data to AQS and provides details on the following monitoring agency requirements. Monitoring agencies must:

- Report NATTS data to AQS within 180 days from the end of the calendar quarter in which samples were collected
- Report concentration data for all Tier I NATTS required HAPs
- Verify and validate data according to the monitoring agency policies
- Report QA data (field blanks, trip blanks, collocated, duplicate, replicate analysis, and lot blanks)
- Qualify data appropriately in relation to the MDL (EPA plans to implement automatic flagging for measured concentrations)
- Add other qualifiers as necessary when data do not meet acceptance criteria
- Report MDLs with the sample data
- Report data in appropriate units in standard conditions (except PM₁₀ metals)
- Verify data were input to AQS properly

The concentrations of all HAPs measured during the execution of the NATTS Program must be input into AQS within 180 days from the end of the calendar quarter during which the applicable air samples were collected. All data uploaded to AQS must have been previously verified and validated per the requirements codified in the cognizant monitoring agency's quality system. Data preparation and entry are also the responsibility of each participating monitoring organization.

AQS permits entry of qualifier codes consisting of the following four different types: Informational Only, Null Data Qualifier, QA Qualifier, and Request Exclusion. Request Exclusion qualifiers do not apply to NATTS data. All uploaded data must be appropriately qualified, as necessary, in AQS. More than one qualifier may be reported with a concentration value to provide additional information regarding the applicable concentration result. However, the null data qualifier flag must not be entered with other flags, as such a flag indicates that no concentration data are reported. Invalidation of concentration results and the subsequent assignment of a null qualifier code in AQS require careful consideration and should be consistent with data review and reporting procedures in the monitoring agency QAPP. Data which do not meet method QC requirements may still be of use and should be entered with the appropriate QA qualifier code. AQS qualifier codes appropriate for qualification of NATTS data are listed in Table 3.3-2 (excludes Null Data Qualifier codes).

Table 3.3-2. AQS Qualifier Codes Appropriate for NATTS Data Qualification

Qualifier Code	Qualifier Description	Qualifier Type Code
1	Deviation from a CFR/Critical Criteria Requirement	QA
2	Operational Deviation	QA
3	Field Issue	QA
4	Lab Issue	QA
5	Outlier	QA
6	QAPP Issue	QA
7	Below Lowest Calibration Level	QA
CC	Clean Canister Residue	QA
CL	Surrogate Recoveries Outside Control Limits	QA
DI	Sample was diluted for analysis	QA
EH	Estimated; Exceeds Upper Range	QA
FB	Field Blank Value Above Acceptable Limit	QA
FX	Filter Integrity Issue	QA
HT	Sample pick-up hold time exceeded	QA
IC	Chem. Spills & Indust Accidents	INFORM
ID	Cleanup After a Major Disaster	INFORM
IE	Demolition	INFORM
IH	Fireworks	INFORM
II	High Pollen Count	INFORM
IJ	High Winds	INFORM
IK	Infrequent Large Gatherings	INFORM
IM	Prescribed Fire	INFORM
IP	Structural Fire	INFORM
IQ	Terrorist Act	INFORM
IR	Unique Traffic Disruption	INFORM
IS	Volcanic Eruptions	INFORM
IT	Wildfire-U. S.	INFORM
J	Construction	INFORM
LB	Lab blank value above acceptable limit	QA
LJ	Identification Of Analyte Is Acceptable; Reported Value Is An Estimate	QA
LK	Analyte Identified; Reported Value May Be Biased High	QA
LL	Analyte Identified; Reported Value May Be Biased Low	QA
MD	Value less than MDL	QA
MX	Matrix Effect	QA
ND	No Value Detected	QA
NS	Influenced by nearby source	QA
QX	Does not meet QC criteria	QA
SQ	Values Between SQL and MDL	QA
SS	Value substituted from secondary monitor	QA
SX	Does Not Meet Siting Criteria	QA
TB	Trip Blank Value Above Acceptable Limit	QA
TT	Transport Temperature is Out of Specs	QA
V	Validated Value	QA
VB	Value below normal; no reason to invalidate	QA
W	Flow Rate Average out of Spec.	QA

The most up-to-date AQS codes and descriptions, including qualifier codes and definitions, are available at the following URL:

<https://www.epa.gov/aqs/aqs-code-list>

Concentrations of HAPs uploaded to AQS must be flagged according to whether they are above or below the sample quantitation limit (SQL) or method detection limit (MDL) thresholds. Concentration data less than the laboratory MDL must be flagged with the QA qualifier code MD, data greater than or equal to the MDL but less than the SQL (3.18-fold the MDL) must be flagged using the QA qualifier code SQ. All concentration values for qualitatively identified analytes, even those less than MDL, must be reported to AQS and must not be censored by substitution of one half the MDL, by replacement with 0, or by any other method. Negative concentrations must not be translated to zero for reporting purposes. Where qualitative identification acceptance criteria are not met for a given HAP, its concentration must be reported as zero and flagged as ND. The convention for reporting concentration data and the associated QA flags are shown in Table 3.3-3.

Table 3.3-3. Required AQS Quality Assurance Qualifier Flags for Various Concentrations Compared to a Laboratory’s MDL and SQL

Concentration Level	Reported Value	Associated QA Flag
≥ SQL	measured concentration	no flag
≥ MDL but < SQL	measured concentration	SQ
< MDL	measured concentration	MD
HAP not qualitatively identified	0	ND

The MDL for a given HAP must be reported to AQS along with the HAP’s concentration or AQS will reject the submission. The reported MDL should ideally be normalized to the collected air volume for the respective air sample. Normalization of the MDL to the collected air volume is required when the collected air volume for the sample is greater than 10% different from the target collected air volume. If the total collected air volume is not within 10% of the target collected air volume, the monitoring organization should take corrective action which may involve troubleshooting the sampling unit and verifying calculations. For example, the target collected air volume for carbonyls sampling at 0.75 L/min is 1.08 m³ and the formaldehyde MDL is 0.052 µg/m³ for this target volume. For a total collected sample volume of 0.95 m³, the collected volume is ~12% lower than the target, and requires normalization of the formaldehyde MDL as follows (MDL increases by the ~12% to account of the reduced sample volume):

$$\frac{0.052 \mu\text{g}/\text{m}^3 \cdot 1.08 \text{ m}^3}{0.95 \text{ m}^3} = 0.059 \mu\text{g}/\text{m}^3$$

Reporting units must be consistent across the NATTS network to ensure that data may be statistically combined with minimal manipulation. HAPs must be reported in the following unit conventions:

- VOCs – parts per billion by volume (ppbv)
- Carbonyls – mass per unit volume (e.g. µg/m³ or ng/m³)
- PAHs – mass per unit volume (e.g. µg/m³ or ng/m³)
- Metals – mass per unit volume (e.g. µg/m³ or ng/m³)

All concentrations, with the exception of those for PM₁₀ metals, must be reported to AQS corrected to the standard conditions of 760 mm Hg and 25°C. PM₁₀ metals data must minimally

be reported in local conditions but may also be reported in standard conditions at the discretion of the monitoring organization. Except for PM₁₀ metals, this requires that sites calibrate sampling unit instruments in standard conditions or that conversion to standard conditions is performed with average temperature and barometric pressure readings taken during sample collection.

Sample collection must be performed from midnight to midnight local standard time (no correction for daylight savings time) which may require adjustment of recorded collection times generated by sampling unit clocks to ensure values are accurately input into AQS. Clock timers controlling sampling unit operation must be adjusted so that digital timers are within ± 5 minutes of the reference time (cellular phone, GPS, or similar accurate clock) and mechanical timers within ± 15 minutes.

NATTS agencies are required to report data for each of the Tier I analytes listed in Table 1.2-1 and are also encouraged to report data collected for Tier II analytes. Careful attention must be paid to coding of data uploaded to AQS to ensure that the five-digit parameter code is accurate and that the associated units comply with those listed above.

NATTS sites may have numerous monitors collecting data for programs besides NATTS. Each individual monitor of a given type (VOCs, carbonyls, PM₁₀ metals, and PAHs) and duplicate samples collected from a single monitor are to be assigned a parameter occurrence code (POC) by the state, local, or tribal agency (SLT). There is no guidance on how POCs are assigned by SLTs and a survey of NATTS sites indicates that several monitors can be assigned the same POC. Data uploaded to AQS indicate the assigned POC, but the POC does not indicate whether the associated data are from a primary monitor, duplicate sample from the primary monitor, duplicate sample from a duplicate monitor, or collocated sample. Due to the ambiguous nature of POC assignment, each NATTS agency must prescribe and maintain a legend of POCs for minimally each of the four monitor types required for NATTS in the annual network plan (ANP) or other controlled document. The recommended convention is to assign a lower POC to the primary monitor and a higher POC to the duplicate and/or collocated monitor.

QA data including, but not limited to, field QA samples such as field and trip blanks and collocated and duplicate test samples, laboratory QA results from replicate analyses (as required by the workplan), and lot blanks must be reported to AQS. AQS also accepts laboratory blanks and laboratories are not required to, but may, report method blank data to AQS. Guidance for reporting QA samples (blanks and precision samples – collocated, duplicate, and replicate samples) is included in Appendix B.

Prior to submission of data to AQS, all data must be reviewed to ensure the parameter code, POC, unit code, method code, and any associated qualifier or null codes are properly assigned. In addition, the reported parameters should specify the NATTS network affiliation.

AQS instructions for data upload are described in the AQS User Guide and additional AQS manuals and guides available at the following URL:

<http://www3.epa.gov/ttn/airs/airsaqs/manuals/>

Additional assistance is available by calling the AQS help line at (866) 411-4372.

3.3.1.3.15.1 Corrections to Data Uploaded to AQS

If it discovered during data validation, as a result of corrective action, or through other means that erroneous data have been reported to AQS, the erroneous data must be deleted, and the corrected data uploaded to AQS. EPA Region staff must be notified when the erroneous data are discovered and SLTs must notify the EPA Region to correct the records in AQS when changes are needed to large swaths of data (e.g. a calendar quarter) or data from previous calendar years are to be altered. Monitoring agencies should also notify data users which may have provided notification of data query (as is done for AQS data pulls for conducting the NATTS assessments and data analysis for preparing the NATA), as the updated data may impact the data user's analysis outcomes.

3.3.1.3.16 Records Retention and Archival, and Data Backup. All records required to reconstruct activities to generate the concentration data for NATTS Program samples must be retained for a minimum of six years. The basis for the six-year retention period is that this covers the two successive three-year periods over which trends in HAP concentrations are determined. If problematic or anomalous data are observed during trends analysis, the archived records will be available for review to investigate the suspicious data. Quality system documents such as QMPs, QAPPs, and SOPs, sample collection and analysis records, maintenance logs, reagent logs, etc. must also be retained for at least six years. Requirements for records retention, including electronic records, must be prescribed in the QMP, agency NATTS QAPP, or similar controlled policy document.

Electronic data must also be retained for a minimum of six years. Data generated by sampling and analysis instruments, including all QA/QC data, as well as data stored in databases and/or in a LIMS must be backed up on a periodic basis as defined in an applicable quality system document such as the QAPP. Archived electronic data must be stored in a manner such that they are protected from inadvertent alteration. Additionally, monitoring agencies must maintain accessibility to the archived data which may include maintaining legacy software systems or computers or may involve conversion of the data to a format which is compatible with current computers and software systems. Monitoring agencies should consider the compatibility of the archived data when upgrading or replacing computer systems and software to ensure the archived data remain accessible.

3.3.1.3.17 Safety. While not strictly a quality system element, safety is integral in ensuring the continued collection of quality data. Each monitoring organization must codify appropriate safety requirements and procedures within the NATTS QAPP or similar controlled policy document. For monitoring organizations with existing safety plans or programs, these may be referenced within the QAPP. Safety plans should include information regarding safety equipment, inspection frequency of safety equipment, and safety training frequency.

3.3.2 Standard Operating Procedures. Each monitoring organization conducting NATTS Program work must develop and maintain SOPs, however named, which must describe in detail the procedures for performing various activities needed to execute air sampling, sample

analysis, data reduction, and data reporting, among others, for the NATTS program. It is not acceptable to simply cite a method document (e.g., EPA Compendium Method TO-11A) or instrument manual as the SOP, although these documents may serve as the basis for an SOP and may be referenced in the SOP. Instrument manuals and the compendium methods do not include sufficient detail on the specific procedures and/or equipment information necessary to perform the procedures and generally offer several different procedures or conventions for performing activities or operating equipment. SOPs must reflect current practice and the work performed must be in accordance with SOPs. SOPs must be written with sufficient detail to enable an individual with limited experience with or knowledge of the procedure, but with basic understanding of the procedure, to successfully perform the procedure when unsupervised. Production, review, revision, distribution, and retirement of SOPs must conform to the requirements prescribed by the monitoring organization's document control system as discussed in Section 3.3.1.3.5.

SOPs can be developed in many formats but should minimally contain information regarding the following, where applicable:

- Title (e.g., Collection of Ambient VOCs Samples in Stainless Steel Canisters)
- Scope and Objectives (e.g., covers sample collection but not analysis)
- References (e.g., EPA Compendium Method TO-11A)
- Definitions and Abbreviations
- Procedures – instructions (usually step-by-step) for performing activities within the scope of the SOP including information on required materials, reagents, standards, and instruments; sample preparation; instrument calibration and analysis, and data analysis and reporting procedures, among other information, as required
- Interferences
- Calculations
- Quality control acceptance criteria with associated corrective actions
- Safety information
- Revision history

The author of each SOP must be an individual knowledgeable with the activity and the organization's internal structure who has the responsibility for the veracity and defensibility of the document's technical content. A team approach may be followed to develop the SOP, especially for multi-tasked processes where experience of a number of individuals is critical to the procedure. SOPs must be approved in accordance with Section 3.3.1.3.5 of this TAD and must be revised when they no longer reflect current practices. At a minimum, SOPs are to be reviewed by the author and a member of QA to determine if revisions are needed and these reviews and revisions must be documented. The frequency for review is recommended to be annually, but must not exceed three years, and the period must be prescribed in the monitoring agency's NATTS QAPP, QMP, or similar controlled document. Once a new version is effective, the previous version must be retired and may not be referenced for conducting procedures.

3.4 References

1. Environmental Protection Agency. (September 2005). *Quality Assurance Guidance Document. Quality Management Plan for the National Air Toxics Trends Stations*. (EPA Publication No. EPA/454/R-02-006). Office of Air Quality Planning and Standards. Emission, Monitoring, and Analysis Division. Research Triangle Park, North Carolina. Available at (accessed October 19, 2016): <https://www3.epa.gov/ttnamti1/files/ambient/airtox/nattsqmp.pdf>
2. Environmental Protection Agency. (March 2001). *EPA Requirements for Quality Assurance Project Plans. EPA QA/R-5* (EPA Publication No. EPA/240/B-01-003). Office of Environmental Information, Washington, DC. Available at (accessed October 19, 2016): https://www.epa.gov/sites/production/files/2016-06/documents/r5-final_0.pdf
3. Environmental Protection Agency. (December 2002). *Guidance for Quality Assurance Project Plans. EPA QA/G-5* (EPA Publication No. EPA/240/R-02-009). Office of Environmental Information, Washington, DC. Available at (accessed October 19, 2016): <https://www.epa.gov/sites/production/files/2015-06/documents/g5-final.pdf>
4. Environmental Protection Agency. (May 2013). *Quality Assurance Handbook for Air Pollution Measurement Systems, Volume II*. (EPA Publication No. EPA-454/B-13-003). Office of Air Quality Planning and Standards, RTP, NC. Available at (accessed October 19, 2016): <https://www3.epa.gov/ttnamti1/files/ambient/pm25/qa/QA-Handbook-Vol-II.pdf>
5. Environmental Protection Agency. (April 20, 2016). *Technical Note – Use of Electronic Logbooks for Ambient Air Monitoring*. Office of Air Quality Planning and Standards, RTP, NC. Available at (accessed October 19, 2016): https://www3.epa.gov/ttnamti1/files/policy/Electronic__Logbook_Final_%204_20_16.pdf
6. Environmental Protection Agency. (November 2002). *Guidance on Environmental Data Verification and Data Validation. EPA QA/G-8* (EPA Publication No. EPA/240/R-02-004). Office of Environmental Information, Washington, DC. Available at (accessed October 19, 2016): <https://www.epa.gov/sites/production/files/2015-06/documents/g8-final.pdf>

4.0: COLLECTION AND ANALYSIS METHODS

4.1 Method Detection Limits

The MDL as prescribed in 40 CFR Part 136 Appendix B was initially developed and applied to wastewater analyses.¹ Since then, this procedure has been applied to a variety of other matrices and analysis methods to approximate the lowest concentration (or amount) of analyte that can be reported with 99% confidence that the actual concentration (or amount) is greater than zero. As can be seen below in Figure 4.1-1, the Gaussian curve represents analysis of contamination-free method (matrix) blanks and the distribution of their concentration values around zero. The small area of the blank values to the right of the MDL value (indicated by the vertical dashed line) represent the 1% of values which would be considered false positives.

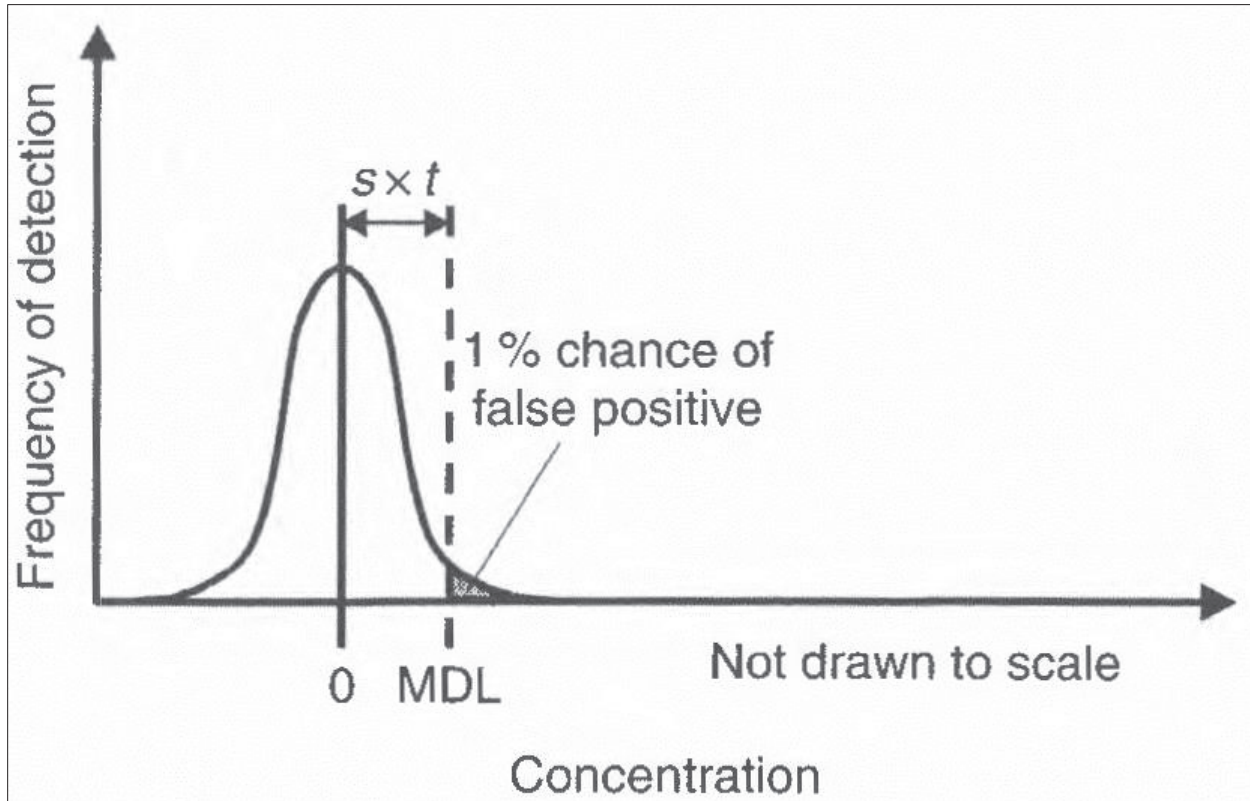

Figure 4.1-1. Graphical Representation of the MDL and Relationship to a Series of Blank Measurements in the Absence of Background Contamination

(Credit: Reference 2 as adapted from Reference 3)

In practical terms, this MDL procedure provides a conservative detectability estimate and aims to ensure that there is a 1% false positive rate – incorrectly reporting the presence of an analyte when it is in fact absent – at the determined MDL concentration. In many cases the analyte will be qualitatively identified (per, for example, the criteria given for the various analytical methods in Section 4.2) at concentrations below the MDL with a signal distinguishable from instrumental

noise. That is to say, the MDL procedure is not protective of false negatives, which is incorrectly concluding that the analyte is absent when it is in fact present; in fact, 50% of the time the analyte present at the MDL concentration will be measured at less than the MDL (the compound will not be 'detected').⁴ This can be seen in Figure 4.1-2 – the solid Gaussian curve represents a series of measurements at the MDL concentration. The measurements in the shaded portion of the curve to the left of the MDL value are false negatives or values measured at less than the MDL. Such values may be properly qualitatively identified despite being less than the MDL value. Therefore, if an analyte is measured at the MDL concentration, the analyte is present 99% of the time; however, for analytes measured at or less than the MDL concentration, 50% of the time the analyte may also be present.

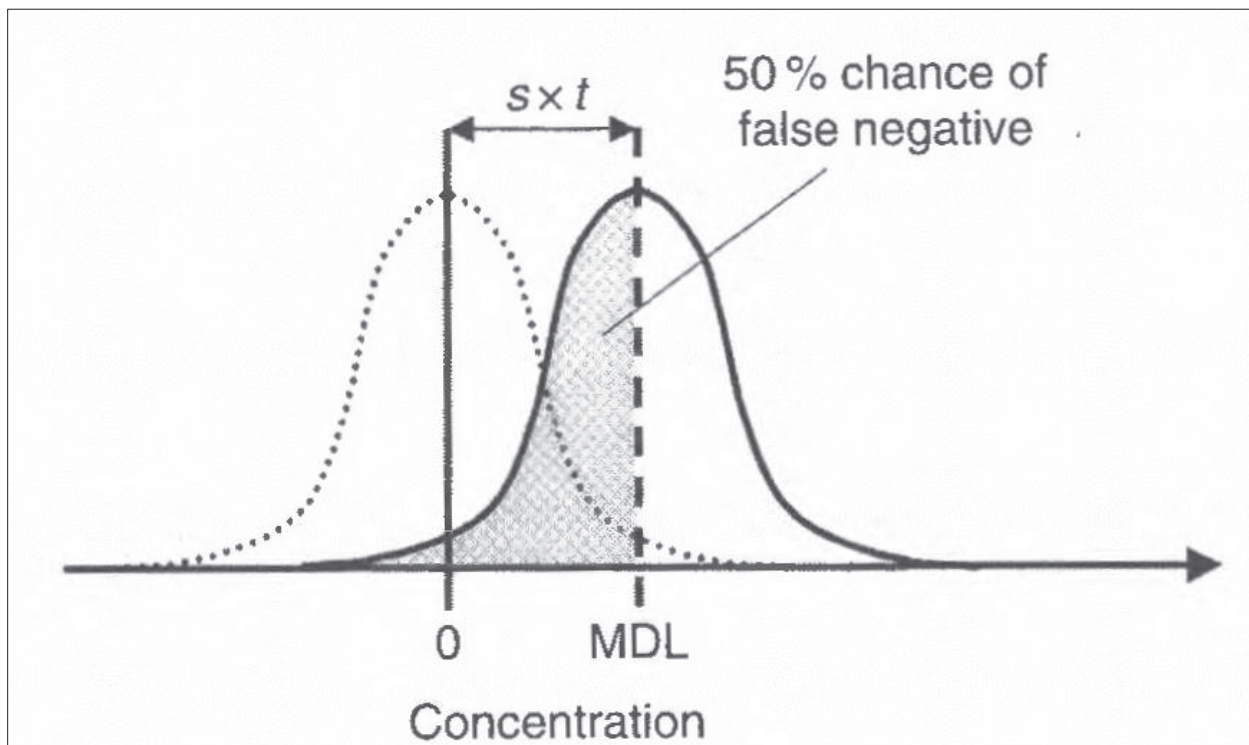

Figure 4.1-2. Graphical Representation of the MDL and Relationship to a Series of Measurements at the MDL Value

(Credit: Reference 2 as adapted from Reference 3)

In summary:

- 99% of the results measured \geq MDL are in fact greater than zero (there is a 1% false positive rate, or chance that such measurements are not actually greater than zero)
- 50% of actual concentrations at the MDL will be reported as \geq MDL
- 50% of actual concentrations at the MDL will be reported as $<$ MDL (they will be false negatives) even though they may still be qualitatively identified and may still in fact be valid identifications

The MDL as described in 40 CFR Part 136 App B and in Reference 1 is a statistical *estimate* of the lowest concentration at which there is a 99% chance that the concentration is greater than zero. The MDL procedure is not simply a characterization of the noise of the instrument nor is it a known level of accuracy ensured at the MDL concentration. The MDL is also not an estimate of the precision or variability of the method. Moreover, the MDL is not simply a representation of the analysis instrument sensitivity, also known as the instrument detection limit (IDL), as the latter does not incorporate the potential effect of the matrix for samples taken through the preparation process (such as extraction or digestion). The IDL establishes the lowest concentration that may be measured with a defined confidence by the instrument, and knowing the IDL is particularly helpful when troubleshooting the MDL process; however, the IDL does not, and must not, replace the MDL.

There are known limitations to the 40 CFR Part 136 Appendix B MDL procedure, not the least of which is that it is a “compromise between statistical respectability and requirements of cost and time.”^{2,3} More specifically for the NATTS program, the MDL procedure prescribed in this TAD of spiking sample collection media in the laboratory does not explicitly take into account the functionality of all portions of the method from collection through analysis. In particular, conducting an MDL study through the probe is impractical for gases and not currently possible for PM₁₀ metals and PAHs. To the extent feasible the impact of the sampling process on detectability is minimized by strongly recommending that bias checks (zero and known standard checks) are performed for carbonyls and VOCs field samplers.

The MDL concentration, as defined in 40 CFR Part 136 Appendix B, is determined statistically by preparing and analyzing minimally seven separate aliquots of a standard spike prepared in the method matrix. All portions of the method and matrix are to be included in the preparation and analysis such that any matrix effects and preparation variability are taken into account. The MDL procedure is an iterative process and, to be meaningful, the MDL procedure must be performed as prescribed.

The MDL procedure adopted for the NATTSs program, which is described in detail in Section 4.1.3.1, builds upon the 40 CFR Part 136 Appendix B by adding some aspects of the proposed method update rule (MUR).⁵ The MUR recognizes that the CFR procedure assumes that blank values are centered around a concentration of zero and does not take into account the potential for background contamination to be present in the sample collection media. If there is a consistent background level of contamination on the sample collection media, as is typical for carbonyls on DNPH cartridge media and metals elements on QFF media, measured blank values will not be centered around zero; rather, they will be centered on the mean blank value. In such cases the MDL must be defined as the value that is statistically significantly greater than the blank value and the 40 CFR Part 136 Appendix B procedure will underestimate the MDL. This occurs since the resulting standard deviation of the MDL replicates (and thus the calculated MDL concentration) prepared in the presence of background contamination will not be different than if there was no discernable background (standard deviation simply evaluates the difference in the spread of the values, not the magnitude of the individual values). The MUR takes into account the media background and adjusts for matrix blanks levels that are not centered around zero.

The MDL procedure prescribed in Section 4.1.3.1 adds few additional steps than those required in the 40 CFR Part 136 Appendix B procedure. The net effect is that if there is little or no contribution of background contamination on the sampling media, the MDL will be no different than that determined previously by 40 CFR Part 136 Appendix B. If the sampling media (or other aspects of the standard preparation of instrumental analysis procedures) contributes blank contamination, the determined MDL will incorporate this average blank background concentration. In all cases, the new MDL will be the concentration at which there is a 99% chance that the actual reported concentration is statistically greater than the mean levels found in blanks.

The DQ FAC Single Laboratory Procedure v 2.4 described in Section 4.1.3.2 is a similar procedure to determine the MDL which takes into account the media background and other potential background contributions. This procedure is more involved and is better suited to laboratories with high sample throughput; however, laboratories may opt to determine MDLs via this procedure.

The MUR-modified 40 CFR Part 136 Appendix B method still has a 50% false negative rate, which is generally recognized as unacceptable for the purposes of environmental monitoring.^{2,3} As a result, concentrations measured at less than the MDL, so long as the qualitative identification criteria have been met, are valid and necessary for trends analysis and substituting or censoring concentrations measured at less than MDL is not permitted. EPA recognizes that many laboratories are not comfortable reporting concentrations measured less than the MDL as these concentrations are outside of the calibrated range of the instrument and are associated with an unknown and potentially large uncertainty. However, actual values reported at less than the MDL are more valuable from a data analyst's standpoint and far superior than censored or substituted values. Addition of qualifiers as prescribed in Section 3.3.1.3.15 and in Table 3.3-1 indicates when values are near, at, and below detection limits and are therefore associated with larger uncertainties.

4.1.1 Frequency of Method Detection Limit Determination. MDLs must be determined minimally annually or when changes to the instrument or preparation procedure result in significant changes to the sensitivity of the instrument and/or procedure. Examples of situations where redetermination of the MDL is required include, but are not limited to:

- Detector replacement
- Replacement of the entire analytical instrument
- Replacement of a large (e.g. > 50%) portion of an agency's canister fleet
- Changing the cleaning procedure for sample collection media or labware which results in a marked reduction in contamination levels

4.1.2 MDL Measurement Quality Objectives. In order to ensure that measurements of air toxics in ambient air are sufficiently sensitive to assess trends in concentrations which may result in health effects due to chronic exposures, a minimum required method sensitivity, or MDL MQO, has been established for each of the core NATTS analytes. Though few changes have been made to MDL MQOs since the beginning of the NATTS Program, as new toxicology data are available, MDL MQOs may be adjusted. The annual NATTS network workplan

template includes the most up-to-date MDL MQO for each core analyte. Laboratories must meet (be equal to or less than) the MDL MQO listed in the most recent NATTS workplan.

The NATTS MDL MQOs are based on concentrations to which chronic exposures may result in unacceptable health risks. While analytical methods prescribed in this TAD are capable of meeting the MDL MQOs, MDLs may be elevated above the MDL MQOs due to background contamination. The convention listed in 40 CFR Part 136 Appendix B accounted for instrumental limitations during the determination of MDLs but did not consider the background or interferences, which, in certain instances, may be several-fold higher than the MDL MQO. As a result, the MUR MDL procedure has been adopted by the NATTS program to provide a more realistic threshold of detection given the limitations of the method and background concentrations attributable to the collection media and analytical instrumentation. The decision to include portions of the MUR for MDL determination for the NATTS Program was carefully weighed by examining historical data from the NATTS network and comparing typical media background levels to evaluate the percentage of data which would additionally be coded as less than the laboratory MDL. The results of the examination indicated that a minimum additional amount of concentration data would be marked as less than the MDL when reported to AQS.⁶

NATTS Tier I core analytes and the concentrations as of March 2015 that correspond to 10^{-6} cancer risk levels, to noncancer risk hazard quotients (HQs) of 0.1, and to MDL MQOs are listed in Table 4.1-1. Refer to the latest NATTS workplan template for the most up-to-date values.

Table 4.1-1. Concentrations of the NATTS Core Analytes Corresponding to a 10^{-6} Cancer Risk, a Noncancer Risk at a HQ of 0.1, and to the MDL MQO

Core Analyte	Cancer Risk 10^{-6} ($\mu\text{g}/\text{m}^3$)	Noncancer Risk at HQ = 0.1 ($\mu\text{g}/\text{m}^3$)	MDL MQO	
			($\mu\text{g}/\text{m}^3$)	(ppbv)
Acrolein	-	0.0020	0.090	0.039
Benzene	0.13	3.0	0.13	0.041
1,3-Butadiene	0.030	0.20	0.10	0.050
Carbon tetrachloride	0.170	19	0.17	0.027
Chloroform	-	9.8	0.50	0.10
Tetrachloroethylene	3.8	4.0	0.17	0.025
Trichloroethylene	0.21	0.20	0.20	0.037
Vinyl chloride	0.11	10	0.11	0.043
Acetaldehyde	0.45	0.90	0.45	0.25
Formaldehyde	0.080	0.080	0.080	0.065
Benzo(a)pyrene	0.00091	0.30	0.00091	NA
Naphthalene	0.029	0.029	0.029	NA
Arsenic (PM ₁₀)	0.00023	0.0030	0.00023	NA
Beryllium (PM ₁₀)	0.00042	0.0020	0.00042	NA
Cadmium (PM ₁₀)	0.00056	0.0020	0.00056	NA
Lead (PM ₁₀)	-	0.015	0.015	NA
Manganese (PM ₁₀)	-	0.0050	0.0050	NA
Nickel (PM ₁₀)	0.0021	0.00081	0.0021	NA

4.1.3 Determining MDLs. MDLs may be determined via one of two procedures. The first procedure in Section 4.1.3.1 is adopted from updates pending at the time this document was revised, an update to the MDL procedure described in 40 CFR Part 136 Appendix B, the MUR.⁵

The second procedure in Section 4.1.3.2 is to determine MDLs via the procedure described in the December 2007 Report of the Federal Advisory Committee on Detection and Quantitation Approaches and Uses in Clean Water Act Programs.¹ Both methods incorporate media blank background levels in the determination of analyte-specific MDLs.

MDL studies must be determined for each instrument employed to analyze samples for the NATTS Program. For laboratories utilizing multiple instruments for a given method, MDL studies must be performed for each instrument (the same samples or extracts may be used for all instruments). In instances where multiple instruments are employed for reporting NATTS Program results for the same analyte class (e.g., two or more HPLC-ultraviolet [UV] instruments), there are two conventions for how to report the MDLs. The preferred convention is to maintain an MDL for each instrument and report the respective MDL from the instrument on which a given sample was analyzed. Alternatively, the most conservative (highest) MDL from the multiple instruments can be reported – though this may not reflect the MDL associated with the sample analysis. It is not appropriate to average the MDL values for reporting.

4.1.3.1 MDLs via 40 CFR Part 136 Appendix B – Method Update Rule. The MDL procedure described in this section is adopted from the procedure as given in 40 CFR Part 136 Appendix B with several changes, based on those proposed in the CFR on February 19, 2015, to explicitly include in the MDL the background (i.e. contamination) contribution of the sample collection media and to incorporate temporal variability in laboratory preparation and instrument performance.⁵ The preliminary work on the MUR identified measuring metals on air filters as an example of where the 40 CFR Part 136 Appendix B method did not generate a realistic concentrations level for the MDL value due to the elevated background contamination on the filter media.

A minimum of seven spiked samples and seven method blanks must be prepared in matrix over the course of a minimum of three different preparation batches. A batch is defined as a group of samples prepared on one day, therefore three different preparation batches would require preparation on three separate days. To properly characterize the variability in preparation, the dates of preparation should be spread out such that they are not consecutive. Analysis of these blanks and spikes must similarly be conducted over the course of three different analysis batches where each sample is only analyzed once. Again, a batch is defined as a group of samples analyzed on one day. Spreading the preparation and analysis over multiple preparation batches and across analysis days is intended to incorporate the variability of both sample preparation and analytical instrumentation that occurs over time. It is preferable to determine an MDL that is representative of the laboratory's capability than to have an unrealistically low MDL determined by selecting the best sampling media (i.e. canisters) and attempting to generate the lowest MDL value possible. Two MDL values are calculated, one MDL for the spiked samples according to the convention in 40 CFR Part 136 Appendix B (MDL_{sp}) and one MDL for the method blanks which includes the media background contribution (MDL_b).

The first step is to select a spiking level for preparing the MDL spiked samples. If too low of a spiking level is chosen, the analyte may not be reliably detected. If too high of a spiking level is chosen, the variability of the method near the actual limits of detection may not be properly

characterized. An appropriate spiking level may be selected by considering the following (in order of importance):

1. The concentration at which the instrument signal to noise ratio is three- to five-fold for the analyte.
2. The concentration at which qualitative identification criteria for the analyte are lost (note that this will be approximately the concentration determined from the MDL process absent of blank contamination).
3. Analysis of a suite of blank samples - calculate the standard deviation of the measured concentration and multiply by 3.
4. Previously acceptable MDL studies and related experience.

Note that the MDL spiking level should not be within the calibration curve; rather, the MDL spiking level should be less than the lowest calibration standard in order to best approximate the MDL. Concentrations within the calibration curve are required to meet precision and bias acceptance criteria and are of a high enough concentration that qualitative identification is certain.

The second step is to prepare the seven or more separate spiked samples (at the level determined in the first step) and seven or more method blank samples. In order to best mimic field-collected samples, each spiked and blank sample must include, to the extent feasible, all portions of the sample matrix and be subjected to the same procedures performed to process field samples in preparation for analysis. Prepare method blanks and spiked samples over the course of three different preparation batches preferably on non-consecutive days.

An efficient method to determine the MDL following this convention is to prepare and analyze an MDL sample on a continuous basis with typical sample batches prepared over the course of several weeks or months. In this scenario, one (or up to three) spikes would be prepared at the time of sample batch preparation and after seven or more data points have been collected for the MDL spikes and for the associated method blanks (which are already required with each analytical batch), the MDL could be calculated. This would alleviate the need to dedicate a significant contiguous block of time to preparing and analyzing MDL samples and method blanks. The following must be taken into consideration during preparation of the MDL samples:

1. Spiked samples must be prepared in matrix (DNPH cartridge, canister, PAH cartridge with quartz fiber filter, or metals Teflon[®] filter or QFF strip).
2. Selection of media should include as much variety as possible (e.g., different canister manufacturers or individual DNPH cartridges selected from different boxes or lots) to best characterize the variability of the method attributable to the use of media representative of field-collected samples.
3. Blank media which do not meet cleanliness criteria for a given analyte should trigger root cause analysis to determine the source of the contamination and should not be used to determine the method blank portion of the MDL. Cleanliness criteria are given in Tables 4.2-3, 4.3-4, 4.4-2, and 4.5-3 for VOCs, carbonyls, metals, and PAHs

collection media, respectively. Of particular concern are background levels of contaminants in canisters and on PUF/XAD cartridges resulting from insufficient cleaning. For DNPH cartridges, media background levels should meet the criteria specified in Method TO-11A (duplicated in Table 4.3-2). Metals quartz fiber filter media typically show elevated background levels of certain elements such as chromium, nickel, manganese, and lead. It is not possible to decrease the background levels of these three elements on QFFs, though EPA is working with manufacturers to reduce the amount of background contamination on the filter media.

The third step is to analyze the samples against a valid calibration curve. QC criteria for the analytical sequences must be met (blanks, laboratory control sample [LCS], calibration checks, etc.). Analyze the samples over the course of minimally three different analytical batches.

1. Perform all MDL calculations in the final units applicable to the method.
2. Calculate the MDL of the spiked samples, MDL_{sp}:
 - a. Following acquisition of the concentration data for each of the seven or more spiked samples, calculate the standard deviation of the calculated concentrations for the spiked samples (s_{sp}). Include all replicates unless a technically justified reason can be cited (faulty injection, unacceptably low internal standard response, etc.), or if a result can be statistically excluded as an outlier.
 - b. Calculate the MDL for the spiked samples (MDL_{sp}) by multiplying s_{sp} by the one-sided student's T value at 99% confidence corresponding to the number of spikes analyzed according to Table 4.1-2. Other values of T for additional samples ($n > 13$) may be found in standard statistical tables.

$$MDL_{sp} = s_{sp} \cdot T$$

Table 4.1-2. One-sided Student's T Values at 99% Confidence Interval

number of MDL samples (n)	degrees of freedom v (n-1)	student's T value
7	6	3.143
8	7	2.998
9	8	2.896
10	9	2.821
11	10	2.764
12	11	2.718
13	12	2.681

- c. Compare the resulting calculated MDL_{sp} value to the nominal spiked amount. The nominal spiked level must be greater than MDL_{sp} and less than 10-fold MDL_{sp}, otherwise the determination of MDL_{sp} must be repeated with an adjusted spiking concentration. For MDL_{sp} values greater than the nominal spike level, the MDL spiking level should be adjusted higher by

approximately two or three-fold. For nominal spike levels which are greater than the 10-fold the MDL_{sp} , the MDL spiking level should be adjusted lower by approximately two or three-fold.

3. Calculate the MDL of the method blanks, MDL_b :
 - a. If none of the method blanks provide a numerical result for the analyte, the MDL_b does not apply. A numerical result includes both positive and negative results for analytes which are positively identified. Non-numeric values such as “ND” would result when the analyte is not positively identified. Only method blanks that meet the specified qualitative criteria for identification (signal to noise, qualifier ion presence, etc.) are to be given a numerical result.
 - b. If the method blank pool includes a combination of non-numeric (ND) and numeric values, set the MDL_b to equal the highest of the method blank results. If more than 100 method blank results are available for the analyte, set the MDL_b to the level that is no less than the 99th percentile of the method blanks. In other words, for n method blanks where $n \geq 100$, rank order the concentrations. The value of the 99th percentile concentration ($n \cdot 0.99$) is the MDL_b . For example, to determine MDL_b from a set of 129 method blanks where the highest ranked method blank concentrations are ... 1.10, 1.15, 1.62, 1.63, and 2.16, the 99th percentile concentration is the 128th value ($129 \cdot 0.99 = 127.7$, which rounds to 128), or 1.63. Alternatively, spreadsheet programs may be employed to interpolate the MDL_b more precisely.
 - c. If all concentration values for the method blank pool are numeric values, calculate the MDL_b as follows:
 - i. Calculate the average concentration of the method blanks (\bar{x}_b).
 - ii. Calculate the standard deviation of the method blank concentrations, s_b .
 - iii. Multiply s_b by the one-sided student’s T value at 99% confidence corresponding to the number of blanks analyzed according to Table 4.1-2. Other values of T for additional samples ($n > 13$) may be found in standard statistical tables.
 - iv. Calculate MDL_b as the sum of \bar{x}_b and the product of s_b and the associated student’s T value:
$$MDL_b = \bar{x}_b + s_b \cdot T$$
4. Compare MDL_{sp} and MDL_b . The higher of the two values is reported as the laboratory MDL for the given analyte.
5. If the MDL is determined as the MDL_{sp} , laboratories should perform verification of the determined MDL by:
 - a. Preparing one or more spiked samples at one to five-fold the determined MDL and analyze the sample per the method to ensure the determined MDL is reasonable. Recall that at the MDL_{sp} concentration there is a 50% chance that the

analyte will not be detected; however, the analyte should be detected at two- to five-fold the determined MDL.

- b. Developing reasonable acceptance criteria for the MDL verification. For example, an MDL verification that recovers 2% of the nominal amount is not realistic, nor is one that recovers 300%. An appropriate starting point for acceptance limits is to double or triple the acceptance window prescribed by the method for the given analyte. For example, TO-15 normally permits benzene LCS recoveries to be 70 to 130% ($\pm 30\%$ error), therefore doubling the MDL verification acceptance limits would permit 40 to 160% recovery. Note that for collection media with a significant background contamination, blank subtraction may be necessary to evaluate the recovery of the MDL verification sample.
- c. Examining the MDL procedure for reasonableness if the verification sample is outside of the laboratory-defined acceptance criteria. Such an examination might include investigating the signal-to-noise ratio of the analyte response in the spiked samples, comparing the MDL to existing instrument detection limits (if known – discussed below), and relying on analyst experience and expertise to evaluate the MDL procedure and select a different spiking level. The MDL study should then be repeated with a different spiking level.

Troubleshooting may include determination of the instrument detection limit (IDL) to evaluate whether the poor or elevated recovery is due to the instrument. The IDL is determined by analyzing seven or more aliquots of a standard, calculating the standard deviation of the measurements, and multiplying the standard deviation by the appropriate student's T value. IDL samples are to be prepared in the same matrix as calibration standards and are not processed through sample collection media as is done for MDL spiked samples (e.g. for TO-11A and TO-13A, the standard would be in solvent, for TO-15 the standard would be typically in a single canister, and for IO3.5 metals analysis the standard would be prepared in the aqueous acid matrix).

Example calculation:

A laboratory is determining the MDL for formaldehyde by TO-11A by spiking commercially-prepared DNPH cartridges. The analyst spiked eight cartridges with formaldehyde-DNPH at 0.030 $\mu\text{g}/\text{cartridge}$ (in terms of the amount of the free formaldehyde) over three separate preparation batches. These eight spiked cartridges and eight additional method blank cartridges were extracted over three different dates. Results were analyzed over three different analysis batches per Method TO-11A yielding the following results:

Cartridge Number	Preparation Batch and Date	Analysis Batch and Date	Spikes ($\mu\text{g}/\text{cartridge}$)	Method Blanks ($\mu\text{g}/\text{cartridge}$)
1	A - September 12, 2015	QR9 - September 13	0.1685	0.1412
2	A - September 12, 2015	QR9 - September 13	0.1651	0.1399
3	A - September 12, 2015	QR9 - September 13	0.1701	0.1402
4	B - September 19, 2015	QR12 - September 21	0.1673	0.1405
5	B - September 19, 2015	QR12 - September 21	0.1692	0.1408
6	C - September 28, 2015	QR16 - September 29	0.1686	0.1403
7	C - September 28, 2015	QR16 - September 29	0.1705	0.1402
8	C - September 28, 2015	QR16 - September 29	0.1696	0.1410

The average (\bar{x}) and standard deviation (s) of measured formaldehyde mass were determined for both the spikes and the method blanks (all in units of $\mu\text{g}/\text{cartridge}$):

$$\begin{aligned}\bar{x}_{\text{sp}} &= 0.1686 \\ \bar{x}_{\text{b}} &= 0.1405 \\ s_{\text{sp}} &= 0.0017 \\ s_{\text{b}} &= 0.0004\end{aligned}$$

To calculate the MDL_{sp} , the standard deviation of the spiked aliquots is multiplied by the associated student's T. The student's T value for eight aliquots is 2.998, corresponding to seven degrees of freedom ($8 - 1 = 7$):

$$\begin{aligned}\text{MDL}_{\text{sp}} &= 0.0017 \mu\text{g}/\text{cartridge} \cdot 2.998 \\ &= 0.0051 \mu\text{g}/\text{cartridge}\end{aligned}$$

The MDL_{sp} is subsequently verified to be less than the spike level, and the spike level is confirmed to be less than 10-fold the MDL_{sp} :

$$\begin{aligned}\text{MDL}_{\text{sp}} &< \text{spike level} < 10\text{-fold MDL}_{\text{sp}} \\ 0.0051 \mu\text{g}/\text{cartridge} &< 0.030 \mu\text{g}/\text{cartridge} < 0.051 \mu\text{g}/\text{cartridge}\end{aligned}$$

Observe that the determined MDL_{sp} is less than the background level of formaldehyde ($\bar{x}_{\text{b}} = 0.1405 \mu\text{g}/\text{cartridge}$) on the DNPH cartridge media; such indicates that the MDL_{sp} is biased low and that background levels must be taken into account.

To calculate the MDL_{b} , the standard deviation of the blank measurements is multiplied by the associated student's T and this product is added to the average blank value, \bar{x}_{b} :

$$\begin{aligned}\text{MDL}_{\text{b}} &= 0.0004 \mu\text{g}/\text{cartridge} \cdot 2.998 + 0.1405 \mu\text{g}/\text{cartridge} \\ &= 0.1417 \mu\text{g}/\text{cartridge}\end{aligned}$$

The MDL_{sp} and MDL_b are compared to determine which is greater, and the greater of the two values is reported as the laboratory MDL for the specific analyte.

$$0.1417 \mu\text{g}/\text{cartridge} > 0.0051 \mu\text{g}/\text{cartridge}$$

In this case, the formaldehyde MDL_b of 0.1417 $\mu\text{g}/\text{cartridge}$ is greater than the MDL_{sp} of 0.0051 $\mu\text{g}/\text{cartridge}$, and is reported as the laboratory MDL for formaldehyde as measured by Method TO-11A.

4.1.3.2 MDLs via DQ FAC Single Laboratory Procedure v 2.4.⁷ The MDL procedure described in this section involves examination and manipulation of historical method blank data to derive the MDL. This procedure must be performed only with method blanks that include all media contributions and processing procedure elements. Also, method blank analyses which were the result of laboratory preparation or analysis errors must not be included.

The DQ FAC procedure requires that historical method blank data be examined to verify that at least 50% of the results are a numerical value (zero, positive concentration, or negative concentration). If fewer than 50% of the method blank values are numerical, or, stated another way, if 50% or more of the values are reported as nondetects, use the procedure described above in Section 4.1.3.1. Once it is determined that the DQ FAC method is applicable, assign method blanks without a numerical value (i.e., non-detect) as zero. Calculate the standard deviation of the included method blanks. A minimum of seven method blanks meeting these criteria is required within the calendar year. If results of more than seven method blanks within the year meet these criteria, all such method blank data should be included in the evaluation.

Calculate the MDL as follows:

$$\text{MDL} = \bar{x}_{mb} + s \cdot K$$

where:

\bar{x}_{mb} = mean result of the method blanks

s = standard deviation of the method blanks

K = is a multiplier for a tolerance limit based on the 99th percentile for $n-1$ degrees of freedom according to Table 4.1-3.

Note that if \bar{x}_{mb} is a negative value, substitute zero for this value.

If 5% or more of the blank results are greater than the MDL, raise the MDL as follows:

1. To the highest method blank result if less than 30 method blank results are available.
2. To the next to highest method blank result if 30 to 100 method blank results are available.
3. To the 99th percentile, or the level exceeded by 1% of all method blank results, if there are more than 100 method blank results available.

Only method blanks that meet the specified qualitative criteria for identification (signal to noise, qualifier ion presence, etc.) are to be given a numerical result.

Table 4.1-3. K-values for n Replicates

n	K	n	K	n	K	n	K
7	6.101	30	3.317	53	2.993	76	2.855
8	5.529	31	3.295	54	2.977	77	2.851
9	5.127	32	3.273	55	2.970	78	2.847
10	4.829	33	3.253	56	2.963	79	2.843
11	4.599	34	3.234	57	2.956	80	2.839
12	4.415	35	3.216	58	2.949	81	2.836
13	4.264	36	3.199	59	2.943	82	2.832
14	4.138	37	3.182	60	2.936	83	2.828
15	4.031	38	3.167	61	2.930	84	2.825
16	3.939	39	3.152	62	2.924	85	2.821
17	3.859	40	3.138	63	2.919	86	2.818
18	3.789	41	3.125	64	2.913	87	2.815
19	3.726	42	3.112	65	2.907	88	2.811
20	3.670	43	3.100	66	2.902	89	2.808
21	3.619	44	3.088	67	2.897	90	2.805
22	3.573	45	3.066	68	2.892	91	2.802
23	3.532	46	3.055	69	2.887	92	2.799
24	3.494	47	3.045	70	2.882	93	2.796
25	3.458	48	3.036	71	2.877	94	2.793
26	3.426	49	3.027	72	2.873	95	2.790
27	3.396	50	3.018	73	2.868	96	2.787
28	3.368	51	3.009	74	2.864	97	2.784
29	3.342	52	3.001	75	2.860	98	2.782

4.1.4 References

1. Glaser, J. A., Foerst, D. L., McKee, G. D., Quave, S. A., & Budde, W. L. (1981). Trace analyses for wastewaters. *Environmental Science and Technology*, 15(12), 1426-1435.
2. Boyd, R. K., Basic, C., & Bethem, R. A. (2008). *Trace Quantitative Analysis by Mass Spectrometry*. West Sussex, England: John Wiley and Sons.
3. Childress, C. J. O., Foreman, W. T., Connor, B. F., & Maloney, T. J. (1999). *New Reporting Procedures Based on Long-Term Method Detection Levels and Some Considerations for Interpretations of Water-Quality Data Provided by the U.S. Geological Survey National Water Quality Laboratory - Open-File Report 99-193*. US Geological Survey. Available at http://water.usgs.gov/owq/OFR_99-193/, accessed October 12, 2016.
4. Keith, L.H. (1992). *Environmental Sampling and Analysis: A Practical Guide*. Chelsea, MI: Lewis Publishers, pp. 93-119.
5. Proposed Method Update Rule to 40 CFR Part 136, Federal Register Volume 80, No. 33, February 19, 2015. Available at <https://www.gpo.gov/fdsys/pkg/FR-2015-02-19/pdf/2015-02841.pdf>, accessed October 12, 2016.
6. Turner, D. J. and MacGregor, I. C., (2016). *How Adoption of the Method Detection Limit Method Update Rule Will Impact the Reporting of Concentrations of Air Toxics in Ambient Air*. Paper presented at the Air and Waste Management Association Air Quality Measurement Method and Technology Conference, Chapel Hill, NC, March 15, 2016.
7. *Report of the Federal Advisory Committee on Detection and Quantitation Approaches and Uses in Clean Water Act Programs, Submitted to the US Environmental Protection Agency*, Final Report 12/28/07. Appendix D, pages D-1 through D-9.

4.2 VOCs – Overview of EPA Compendium Method TO-15

Each agency must codify in an appropriate quality systems document, such as an SOP, or equivalent, its procedures for performing VOC sampling, canister cleaning, and analysis. Various requirements and best practices for such are given in this section. Note that regardless of the specific procedures adopted, the method performance specifications as given in Section 4.2.12 must be met.

Of the 188 HAPs listed in Title III of the CAA Amendments of 1990, 97 of these are VOCs. VOCs are defined as organic compounds having a vapor pressure greater than 10^{-1} Torr at 25°C.¹ VOC air toxics ambient air concentrations are typically measured at the single part per trillion (ppt) to single ppb level. Measurement of these VOCs is based on the techniques described in EPA Compendium Method TO-15^{1,2}, which describe collection of whole air samples into evacuated stainless steel canisters followed by preconcentration of the volatiles for analysis via GC/MS. When initially released, TO-15 indicated the lower limit for concentration measurement was approximately 0.5 ppbv. However, with newer more sensitive mass spectrometer detectors, much lower detection limits are achievable such that the MDL MQOs listed in Table 4.1-1 can be attained. Due to the lack of current and specific guidance for measuring low (sub-ppbv) levels of VOCs in ambient air, at the time of this TAD's release, EPA was collecting public comments to revise TO-15 to include techniques and instrumentation that permit sub-ppbv measurements of VOCs in ambient air. Much of the guidance listed in this section are anticipated to be included in EPA's update of TO-15.

4.2.1 General Description of Sampling and Analytical Methods. An MFC and/or critical orifice regulates the flow of ambient atmosphere into an evacuated passivated stainless steel canister at a known, constant rate over the course of 24 hours. Following completion of collection, the canister is transported to a laboratory for analysis within 30 days of collection. Previous studies suggest that most compounds analyzed via TO-15 are stable for up to 30 days in passivated stainless steel canisters;^{3,4} however, the condition of the wetted surfaces of each individual canister is likely to influence the stability of the VOCs. Analysis of the sample as soon as possible after collection is strongly recommended to minimize changes of the collected sample, especially for HAPs such as acrolein, 1,3-butadiene, and carbon tetrachloride, among others.

VOCs are identified and quantified via cryogenic preconcentration GC/MS and a typical analysis scheme is as follows. A known volume of the whole air (an air parcel from which gases have not been removed and are completely captured for sample collection) is passed through and the VOCs are cryogenically trapped onto a sorbent bed while N₂, O₂, Ar, CO₂, and to the extent possible, H₂O are selectively removed. The volume trapped is measured via MFC or by the change in pressure of a known volume downstream of the sorbent trap. The sample introduction pathway and sorbent bed are then swept with dry inert gas (such as helium) to remove water, while the VOCs are retained on the cold sorbent. After the preconcentration and dehydration, the sorbent is heated to desorb the VOCs and the VOCs entrained in a carrier gas stream where they are refocused and subsequently introduced onto the GC column for separation. After separation on the column, VOCs are ionized in a quadrupole, ion trap, or time of flight (TOF) MS which detects the ion fragments according to their mass to charge (m/z) ratio. The responses

of the ion fragments are plotted against the retention time and compared to the standard chromatogram to identify the compounds in the sample based on retention times and ion fragments of standards analyzed under the same chromatographic and MS conditions.

Method TO-15 addresses sampling of VOCs such that integration of the sample results in a final canister pressure is subambient (< 14.7 psia, or less than the typical ambient atmospheric pressure at the field location) or above ambient (> 14.7 psia, or above the typical ambient atmospheric pressure at the field location). Previous versions of this TAD have disallowed superambient sampling since such is thought to result in depressed recoveries of hydrophilic polar VOCs due to their dissolution into condensed water. However, many of the sites in the NATTS network collect canisters at superambient pressures. Due to a lack of definitive studies demonstrating one method to be superior, this revision of the TAD permits pressurized sampling but *strongly recommends* that collected canister pressures remain less than or equal to 3 psig (~17.7 psia) to minimize the potential for water condensation. Regardless of the chosen final canister pressure, each agency is responsible for ensuring that method performance specifications are met, and specifically that method precision and bias are acceptable for their selected combination of sampling instrument; final canister pressure; canister type; and preconcentration, water management, and analysis techniques.

A previous study by McClenny et al.⁵ indicates that ambient air samples collected above atmospheric pressure may exhibit condensation on the interior canister surfaces. Liquid water inside the canister decreases precision from canister reanalysis since the amount of condensation decreases as air is removed from the canister, and the pressure decreases, which changes the equilibrium of analytes between the liquid and gas phases. For monitoring agencies collecting samples to superambient pressure, samples should not be pressurized above 3 psig to minimize the condensation of liquid water inside the canister.

The calibration and tuning of the MS must be monitored and compensated for by the analysis of internal standards (IS) with each injection and analysis of continuing calibration standards minimally every 24 hours of analysis (recommended every 10 sample injections and concluding each sequence).

The VOCs including, but not limited to, those in Table 4.2-1 may be determined by this method.

Table 4.2-1. VOC Target Compounds and Associated Chemical Abstract Service (CAS) Number via Method TO-15

Target Compound	CAS #
acetone	67-64-1
acrolein ^{a b}	107-02-8
acrylonitrile	107-13-1
benzene ^{a b}	71-43-2
benzyl chloride	100-44-7
bromodichloromethane	75-27-4
bromoform (tribromomethane)	75-25-2
1,3-butadiene ^{a b}	106-99-0
2-butanone (methyl ethyl ketone)	78-93-3
carbon disulfide	75-15-0
carbon tetrachloride (tetrachloromethane) ^{a b}	56-23-5
chlorobenzene	108-90-7
chloroform (trichloromethane) ^{a b}	67-66-3
cyclohexane	110-82-7
dibromochloromethane	124-48-1
1,2-dibromoethane ^b	106-93-4
1,2-dichlorobenzene	95-50-1
1,3-dichlorobenzene	541-73-1
1,4-dichlorobenzene	106-46-7
dichlorodifluoromethane (Freon-12)	75-71-8
1,1-dichloroethane	75-34-3
1,2-dichloroethane ^b	107-06-2
1,1-dichloroethene	75-35-4
cis-1,2-dichloroethene	156-59-2
trans-1,2-dichloroethene	156-60-5
1,2-dichloropropane ^b	78-87-5
cis-1,3-dichloropropene ^b	10061-01-5
trans-1,3-dichloropropene ^b	10061-02-6
1,2-dichlorotetrafluoroethane (Freon-114)	76-14-2
1,4-dioxane	123-91-1
ethanol	64-17-5
ethyl acetate	141-78-6
ethyl chloride (chloroethane)	75-00-3
ethylbenzene	100-41-4
4-ethyl toluene	622-96-8
heptane	142-82-5
hexachloro-1,3-butadiene	87-68-3
hexane	110-54-3
2-hexanone (methyl butyl ketone)	591-78-6
isoprene	78-79-5
isopropyl alcohol	67-63-0
methanol	67-56-1
methyl bromide (bromomethane)	74-83-9
methyl chloride (chloromethane)	74-87-3
methyl isobutyl ketone (4-methyl-2-pentanone)	108-10-1
methyl methacrylate	80-62-6
methyl tert-butyl ether	1634-04-4
methylene chloride (dichloromethane) ^b	75-09-2
propene	115-07-1

Table 4.2-1. VOC Target Compounds and Associated Chemical Abstract Service (CAS) Number via Method TO-15 (Continued)

Target Compound	CAS #
styrene	100-42-5
1,1,1,2-tetrachloroethane	630-20-6
1,1,2,2-tetrachloroethane ^b	79-34-5
tetrachloroethene ^{a b}	127-18-4
tetrahydrofuran	109-99-9
toluene	108-88-3
1,2,4-trichlorobenzene	120-82-1
1,1,1-trichloroethane	71-55-6
1,1,2-trichloroethane	79-00-5
trichlorofluoromethane (Freon 11)	75-69-4
1,1,2-trichloro-1,2,2-trifluoroethane (Freon-113)	76-13-1
1,2,4-trimethylbenzene	95-63-6
1,3,5-trimethylbenzene	108-67-8
trichloroethene ^{a b}	79-01-6
vinyl acetate	108-05-4
vinyl bromide	593-60-2
vinyl chloride (chloroethene) ^{a b}	75-01-4
m&p-xylene	108-38-3 (m)/106-42-3 (p)
o-xylene	95-47-6

^a NATTS Tier I core analyte

^b NATTS PT target analyte

4.2.1.1 Sampling Pathway. All wetted sampling surfaces that contact the sampled atmosphere, including the inlet probe, must be of chromatographic grade stainless steel or borosilicate glass. Stainless steel tubing may be additionally fused silica lined which increases the inertness of the flow path. While PTFE Teflon is permitted, its use is not recommended as high molecular weight compounds may adsorb to the surface. Use of other materials such as copper, FEP Teflon[®], or rubber is not permitted, as they have active sites or provide opportunities for VOCs to adsorb and later desorb.

4.2.1.2 Particulate Filtration. A 2- μ m pore size sintered stainless steel particulate filter must be installed on the sampling unit inlet for all VOC collection. If employing a standalone VOC inlet probe, a particulate filter placed further upstream in the sampling pathway may permit a longer period between sampling inlet pathway cleaning. Failure to install a particulate filter allows particulate residue such as dust and pollen to adhere to the interior of the sampling unit (to valves, MFC, etc.) and to be pulled into the evacuated canister during sample collection. Once inside the canister, particulate matter can form active sites, adsorb analytes, and/or provide reactants which may degrade and form target analytes or interferants, potentially rendering the canister irreversibly contaminated. The particulate filter must be replaced minimally annually or more frequently if in areas with high airborne PM levels which may result in decreased flows or decreased collected pressures.

4.2.2 Precision – Sample Collection and Laboratory Processing. Each agency must prescribe procedures that it will follow to assess VOCs precision in the NATTS QAPP, SOP, or similar controlled document. Given below are the various types of precision and associated frequency requirements for VOCs.

Precision between duplicate, collocated, and replicate analysis samples must be $\leq 25\%$ relative percent difference (RPD) for target compound concentrations \geq five-fold the laboratory MDL. Both sample results must be qualified when entered into AQS for instances in which collocated or duplicate samples fail this precision specification. For precision criteria failures of replicate analyses, the value reported as the RD transaction must be qualified. Root cause analysis must be performed to investigate and correct the failure. If a root cause cannot be identified, results should be qualified as estimated. Please refer to the list of qualifiers in Table 3.1-1.

4.2.2.1 Sample Collection and Analysis Precision. Collocated and duplicate samples are compared to the primary sample to determine the precision inclusive of all sample collection and analysis procedures.

For samples to be collocated, each sampling unit must have its own pathway to the ambient atmosphere. If collected from a manifold, each sampling unit must have a dedicated manifold for it to be collocated; otherwise this configuration is defined as duplicate. The rationale behind this distinction is that there is potential non-homogeneity of the sampled atmosphere in the manifold when compared to the ambient atmosphere. Any effect of the manifold impacts both sampling units and they are not sampling truly independently from the ambient atmosphere. If both sampling unit inlets connect to the same inlet manifold, the samples are duplicate, not collocated, as shown in Figure 4.2-1. To summarize,

- Collocated samplers must have two separate flow control devices and two separate discrete inlet probes to the ambient atmosphere. If applicable, each sampling unit must connect to a separate manifold. Collocated sampling inlet probes must be within 1 to 4 meters of the primary sampling inlet probe.
- Duplicate sampling is performed in situations where two canisters are collected through a single inlet probe, which includes a common inlet manifold.

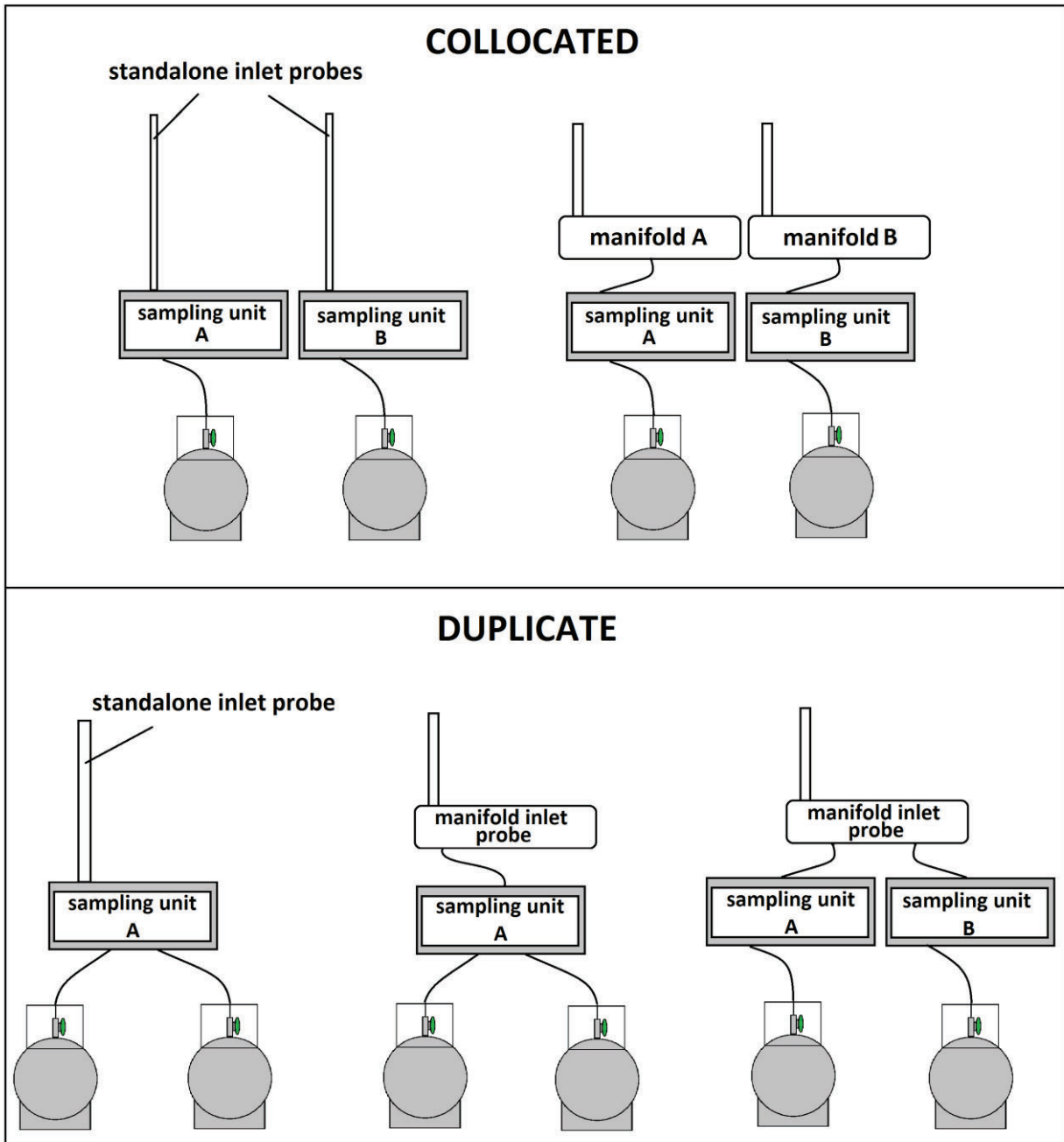

Figure 4.2-1. Collocated and Duplicate VOC Canister Sample Collection

Collocated or duplicate VOC sampling, if performed (as detailed in the workplan), must be conducted at a minimum frequency of 10%. This is equivalent to a minimum of six collocated samples per year, or roughly one every other month, for sites conducting one-in-six days sampling for a total of 61 primary samples annually. More frequent collocated sample collection provides additional sample collection precision and is encouraged where feasible.

4.2.2.2 Laboratory Analytical Precision. Several analysis aliquots can be removed from a collected canister which affords replicate analysis to evaluate analytical precision. The same

sample is injected twice and the results are evaluated for precision as RPD. The required frequency for replicate analyses reported to AQS is prescribed in the workplan, but is recommended to be performed on a one-per-batch frequency or one-in-20 sample injections, whichever is more frequent. Monitoring organizations are encouraged to report all replicate analysis results to AQS.

4.2.3 Sample Collection Procedures

4.2.3.1 Sampling Equipment Specification. Various sampling instruments are commercially available. Such systems may permit simultaneous collection of VOCs canisters and carbonyl cartridges or include secondary channels for collection of duplicate VOCs canister samples. Regardless of the additional features, each sampling unit must minimally include the following options:

- Elapsed time indicator
- Multi-day event control device (timer)
- Latching solenoid valve with a low temperature rise coil
- Pressure gauge or pressure transducer to perform leak checking of canister connection
- MFC (preferred) or critical orifice to control sampling flow

All wetted surfaces of the flow path in the sampling unit must be constructed of chromatographic grade stainless steel or borosilicate glass. Stainless steel may be additionally deactivated with fused silica linings. Use of PTFE Teflon is discouraged as it can behave as a sorbent for high molecular weight VOCs. Inclusion of glass-lined stainless steel is discouraged as it is prone to breakage which can cause flow restrictions.

4.2.3.2 Sample Collection, Setup, and Retrieval

4.2.3.2.1 Sample Setup. It is strongly recommended that the initial canister pressure be checked prior to sample collection by measurement of the canister vacuum with a calibrated pressure gauge or pressure transducer. If a built-in gauge on the sampling unit cannot be calibrated, a standalone gauge should be employed for this measurement. This initial pressure should be documented on the sample collection form. Canisters must show > 28 inches Hg vacuum to conduct sampling.

Once vacuum is verified, the canister is connected to the sampling unit and a leak check is performed. A leak check may be performed by quickly opening and closing the valve of the canister to generate a vacuum in the sampling unit. The vacuum/pressure gauge in the sampling unit should be observed for a minimum of 5 minutes to ensure that the vacuum does not change by more than 0.2 psi. Commercially-available canister sampling units may include a leak check routine. For onboard leak check routines, the leak check criteria should be equivalent or better than those listed above. If a leak is detected, fittings should be tightened to locate the source of

the leak. Sample collection must not commence until a successful leak check is attained. Leak check pressure change and duration is documented on the field collection form.

Following successful leak check, the sample collection program is verified and the canister valve is opened.

4.2.3.2.2 Subambient Sample Collection. Subambient pressure sample collection results in a canister pressure that is approximately 10 to 13 psia (2 to 10 inches Hg vacuum). Sample collection must be performed at a constant flow rate over the 24-hour collection period. Flow rates are typically 2.5 to 3.5 mL/minute for 6-L canisters.

As discussed earlier in Section 4.2.1, the management of water in sample collection is important to the ability to remove air from the canister that is representative of the atmosphere initially collected. At subambient pressures, the partial pressure of water vapor does not typically exceed the equilibrium vapor pressure at the typical analysis temperature, thus water generally will not condense on the interior surfaces of the canister.

Subambient sample collection does not include a pump in the sampling pathway. With fewer components, moving parts, seals, and surfaces, there is generally less risk of contaminating a collected sample. A less complex sampling system has fewer parts to wear out and break, simplifying maintenance.

Two disadvantages with subambient sample collection relate to contamination due to leaking and a smaller overall volume of collected gas for analysis. A canister leak on a subambient pressure sample will cause ambient air to enter the canister and contaminate the sample, invalidating the sample. Moreover, a canister at subambient pressure contains less air than an equivalent superambient sample, which limits the number of aliquots that may be effectively removed from the canister before there is insufficient gas remaining for analysis.

4.2.3.2.3 Superambient (Positive) Pressure Sampling. Superambient pressure sampling (positively pressurized sampling) involves collection of samples above atmospheric pressure utilizing a pump to push air into the canister. As discussed earlier in Section 4.2.1, sample collection at pressures above ambient pressure may result in water condensation on the interior walls of the canister.⁵ It is theorized that this condensation may lead to poor representation of hydrophilic polar compounds in the aliquot of gas removed from the canister for analysis. An advantage of superambient pressure sample collection is that if the canister leaks slightly, the sample will not become contaminated so long as the canister pressure remains greater than atmospheric pressure.

A disadvantage of superambient sample collection is that it requires incorporation of a pump and additional valves in the sampling pathway, which provide additional opportunities for contamination over time when compared to subambient sampling methods which do not require the additional pumps and valves.

Some sampling systems are susceptible to condensation in the flow pathway during high-dewpoint conditions. This condensation manifests in the high pressure area between the pump

and the bypass valve and is evidenced by rough pressure responses when the bypass valve is operating. To alleviate this condensation, the bypass valve should be kept as open as possible to maximize the air flow through the sampler and minimize the condensation.

4.2.3.2.4 Sample Retrieval. Following completion of sample collection, it is strongly recommended that the final canister pressure be measured with a calibrated pressure gauge and recorded on the sample collection form. If an on-board gauge on the sampling unit cannot be calibrated, a standalone calibrated gauge should be used. The sample start and stop times as well as the elapsed collection time must also be recorded on the sample collection form. The sample custody form must be completed and accompany the collected sample at all times until relinquished to the laboratory. COC documentation must comply with Section 3.3.1.3.7.

Sampling units which incorporate computer control of the sampling event with associated data logging may provide the above information which should be printed and attached to the sample collection form or transcribed. If transcribed, the transcription must be verified by another individual. For such sampling units, the data logged should be reviewed to ensure the sample collected appropriately and there are no flags or other collection problems that may invalidate the collected sample. Collected data should be downloaded and provided to the analysis laboratory.

4.2.3.3 Sampling Schedule and Duration. VOC sample collection must be performed according to the national sampling schedule at one-in-six days for 24 ± 1 hours beginning at midnight and concluding on midnight of the following day, standard local time, unadjusted for daylight savings time. For missed or invalidated samples, a make-up sample should be scheduled and collected per Section 2.1.2.1. Clock timers controlling sampling unit operation must be adjusted so that digital timers are within ± 5 minutes of the reference time (cellular phone, GPS, or similar accurate clock) and mechanical timers within ± 15 minutes.

4.2.3.4 Sampling Train Configuration and Presample Purge. Sampling unit inlets may be connected to a standalone inlet probe or may be connected to a sampling inlet manifold with a single inlet probe. If connected to a manifold inlet, the VOC sampling line must be connected to the port closest to the manifold inlet probe. Inlet manifolds must incorporate a blower to pull ambient air through the manifold; the manifold flow rate should be minimally two times greater than the total demand of the systems connected to the manifold. An exit flow meter should be installed to ensure excess air flow which reduces residence time and ensures that a fresh supply of ambient air is available for sampling. Refer to Section 2.4 for sampler siting requirements.

For either inlet system listed above, the inlet line to the sampling unit must be purged with ambient air such that the equivalent of a minimum of 10 air changes is completed just prior to commencing sample collection. This purge eliminates stagnant air and flushes the inlet line.

4.2.3.5 Sampling Unit Non-Biasing Certification. Prior to field deployment and annually thereafter, each VOC sampling unit must be certified as non-biasing by collection over 24 hours of both a sample of hydrocarbon-free (HCF) zero air (or equivalent VOC- and oxidant-free air) or zero grade nitrogen and known concentration VOC standard in air.

This certification may be performed as part of an internal audit, however, this certification is best performed following annual maintenance which includes calibration (or calibration checks) of MFCs and pressure gauges and other preventive maintenance, as needed, to ensure the sampling unit is non-biasing prior to field deployment. Equipment such as dynamic dilution systems, connecting tubing, and MFCs should be purged with humidified zero air or nitrogen for sufficient time (typically one hour) to ensure the challenge delivery system is clean.

A best practice is to perform this procedure through the probe (TTP) where the entire sampling train is assessed for bias. Conducting the TTP procedure requires equipment such as portable zero air generators and portable gas-phase dynamic dilution systems and staff familiar with their operation. While the TTP procedure is the best practice, each sampling unit must minimally be bench tested. Suitable test procedures are described below.

Recommended certification check procedures are described below. For agencies which cannot perform the annual maintenance and challenge in-house, manufacturers, the national contract lab, or third party vendors may offer certification services. Regardless of the exact procedure adopted, the performance specifications listed below must be met.

4.2.3.5.1 Zero Check. The zero check is performed by simultaneously providing humidified (50 to 70% RH) hydrocarbon- and oxidant-free zero air (must meet the cleanliness criterion of < 0.2 ppbv or < 3x MDL, whichever is lower) or UHP nitrogen to the sampling unit for collection into a canister and to a separate reference canister connected directly to the supplied HCF zero air gas source. The reference canister collects the challenge gas directly and is the baseline for comparison of the challenge sample. Compounds which show increased concentrations in the challenge sample compared to the reference sample indicate contamination attributable to the sampling unit.

The humidified zero gas flow is provided to a challenge manifold constructed of chromatographic stainless steel. The manifold should include three additional ports for connections to the sampling unit inlet, reference MFC, and a rotameter which acts as a vent to ensure that the manifold remains at ambient pressure. The reference MFC flow is set to approximately the same flow rate as the sampling unit. Zero gas is to be supplied such that there is excess flow to the manifold as indicated by the rotameter on the vent port. Sampling is performed over 24 hours, to simulate real world conditions, into the reference canister and through the sampling unit into the zero challenge canister. Sampling for 24 hours best replicates conditions in the field, however, shorter sampling durations for these challenges are also acceptable.

Analysis by GC/MS for target compounds must show all Tier I core compounds in the zero challenge canister are not greater than 0.2 ppbv or 3x MDL (whichever is lower) higher than the reference canister and the remaining core compounds should also meet these criteria. Where exceedances are noted in the zero challenge canister for Tier I core compounds, corrective action must be taken to remove the contamination attributable to the sampling unit and the sampling unit zero challenge repeated to ensure criteria are met before sampling can be conducted. Subsequent collected field sample results for non-Tier I compounds that fail this criterion must be qualified when input to AQS.

4.2.3.5.2 Known Standard Challenge. The known standard challenge is performed by simultaneously providing a humidified (50 to 70% RH) known concentration standard of target VOCs (at approximately 0.3 to 2 ppb each) in air or UHP nitrogen to the sampling unit for collection into a canister and to a separate reference canister connected directly to the supplied standard gas stream. The reference canister collects the challenge gas directly and is the baseline for comparison of the challenge sample. Compounds which show enhanced or decreased concentrations in the challenge sample compared to the reference sample indicate bias attributable to the sampling unit.

It is recommended that the challenge gas contain all target VOCs, however, a smaller subset of compounds is sufficient provided that each target compound type is represented in the gas mixture (e.g. low molecular weight, fluorinated, chlorinated, brominated, high molecular weight, etc.).

The standard challenge gas is supplied to the challenge manifold by dilution of a gas mixture of VOCs via dynamic dilution with humidified HCF zero air. The manifold should be constructed of chromatographic stainless steel and should include three additional ports for connections to the sampling unit inlet, reference canister, and a rotameter acting as a vent to ensure that the manifold remains at ambient pressure. The reference canister may be collected via MFC, other constant flow device, or a grab sample to characterize the plenum manifold concentrations. Challenge gas is to be supplied such that there is excess flow supplied to the challenge manifold as indicated by the rotameter on the vent port. Samples are collected simultaneously for 24 hours to simulate real world conditions. Sampling for 24 hours best replicates conditions in the field, however, shorter sampling durations for these challenges are also acceptable.

Analysis by GC/MS for target compounds must demonstrate that each VOC in the challenge sample is within 15% of the concentration in the reference sample. All Tier I core compounds in the challenge gas must meet this criterion. For Tier I core compounds exceeding these criteria, corrective action must be taken to address the bias in recovery attributable to the sampling unit. Subsequent collected field sample results for non-Tier I compounds that fail this criterion must be qualified when input to AQS.

Following completion of the known standard challenge, the sampling unit should be flushed with humidified HCF zero air or ultra-high purity (UHP) nitrogen for a minimum of 24 hours.

Once shown as non-biasing, a best practice to assess ongoing bias is to compare fingerprint plots (discussed in Section 3.3.1.3.14.2) of each sample from the site.

4.2.4 Canister Hygiene. At the time of this TAD revision, measuring VOCs in ambient air using passivated stainless steel canisters is approximately a 40-year old technology. While measurement systems have become more sensitive with the advent of selected ion monitoring (SIM) and TOF detection, many agencies are unable to achieve sufficient sensitivity to measure VOCs at ambient concentrations in collected air samples due to the inability to properly clean and maintain canisters. The following sections present requirements and best practices for assessing background levels in canister media and maintaining sufficiently low background levels to the measurement of VOCs in ambient air.

4.2.4.1 Qualification of Canisters. When new canisters are received, it is *strongly recommended* that they be qualified appropriately prior to use for sample collection or for preparation of standards and blanks. New canisters may contain residues such as cutting oils, pump oils, or coating byproducts from the manufacturing process and/or residual contamination from compounds added by manufacturers to perform QC checks on the canisters prior to release to customers. Additionally, new canisters may have defects making them unsuitable for use even after the canisters have been cleaned and treated for the residual contaminants. Such defects may relate to poor valve sealing, active sites from incomplete coating or surface deactivation, or poor canister integrity due to inadequate welds.

Following new canister receipt and before use and annually thereafter, it is *strongly recommended* that canisters be properly cleaned, tested for leaks, and evaluated for bias such that the requisite canister performance specifications are met. As with new canisters, existing canisters in agency fleets may exhibit some of the same problems over time and it is *strongly recommended* that they be qualified on an annual basis to verify they are non-biasing. All canisters in a given fleet need not be qualified at the same time, rather a subset can be qualified on a rolling basis such that all canisters are qualified within the period of a year. For monitoring agencies with large canister fleets, it may not be feasible to assess each canister within a year. In such cases, the monitoring agency should prepare a schedule to assess canisters in a reasonable timeframe (e.g. every 18 months). Suitable procedures are described in the following sections.

4.2.4.1.1 Canister Bias. It is *strongly recommended* that all canisters be evaluated for bias when newly purchased (prior to use for field sample collection or use for laboratory QC sample preparation) and annually thereafter. Assessment for bias of newly purchased canisters or canisters from an existing fleet is performed identically. Canisters which exhibit a positive or negative bias exceeding the criteria below should be segregated and reconditioned before reuse or discarded. Some commercial canister manufacturers offer reconditioning services for their canisters. Consult the manufacturer for methods to clean or recondition cans which fail these bias criteria.

4.2.4.1.1.1 Canister Integrity and Zero Air Check

Within two days following cleaning, preferably the same day, canisters should be pressurized with humidified HCF zero grade air (or UHP N₂). This short duration following cleaning is intended to characterize the canister condition before analytes have a chance to “grow” in the canister. In order to assess leak tightness of the canisters and to best represent the contamination potential from collected field samples, pressurization should be performed so that the final canister pressure closely matches that of the typical pressure of field sample canisters. Subambient pressurization provides less diluent and may provide more measurable target compound mass per injection aliquot. Pressurization above ambient pressure permits removal of larger aliquots of sample gas, and as such affords more opportunities for reanalysis. In either case, canisters must be approximately 2 psi above or below ambient pressure to permit assessment of canister leaks. The leak check process given here is one example for a method to determine canister leak tightness. Other equivalent methods can be performed provided they meet the leak criteria of < 0.1 psi/day. Leak checks are recommended to be performed annually,

however the frequency of performing leak checks must be prescribed in the NATTS QAPP, SOP, or similar controlled document.

Immediately upon pressurization, each canister's pressure is measured with a calibrated gauge for establishment of a baseline. After a minimum of 7 days and after as long as 30 days, each canister's pressure is again measured. Canisters with leak rates > 0.1 psi/day must be removed from service and repaired. This leak rate permits 5% of the sample volume to leak over 7 days and a 20% sample volume leak over 30 days.

The canister should be analyzed within two days of initial pressurization and all Tier I core analytes must be $< 3x$ MDL or < 0.2 ppb, whichever is lower, and non-Tier I compounds should meet this criterion. Note that following this analysis, the canister pressure must be remeasured to accurately assess the canister leak rate as the aliquot removed for analysis changes the canister pressure. Subsequent analysis may be performed minimally at 14 days after pressurization and is highly recommended to be performed at 30 days after initial pressurization. Laboratories may tailor this later timepoint to be representative of the maximum holding time experienced by the laboratory (e.g. 21 days if all samples are analyzed within this time frame from sample collection). Analyses at these later timepoints must show all Tier I core analytes $< 3x$ MDL or < 0.2 ppb, whichever is lower, and non-Tier I compounds should meet this criterion. Intermediate timepoints less than 30 days will likely indicate if there is a problem with a particular canister. Canisters which meet criteria at intermediate timepoints should be analyzed at the 30-day timepoint to verify they are bias free for the 30-day period. If analysis can be performed at only one timepoint after initial pressurization, it is recommended to be at 30 days.

Laboratories have reported growth of oxygenated compounds (e.g. ketones, alcohols, aldehydes) in canisters. Of particular concern in the canister zero air checks is acrolein, which evidence suggests may "grow" in canisters that are stored for extended periods. The mechanism for acrolein growth is not well understood; however, such is widely regarded as problematic in performing ambient concentration analysis. Suggested pathways of acrolein growth are decomposition of particulate residue, slow time-release of acrolein from interstitial spaces within the canister, breakdown of cutting oil residues in valves, or decomposition of other volatile constituents within the canister. Concentrations of target compounds above twice the laboratory MDL should be closely scrutinized as they indicate the presence of canister background concentrations which may cause issues with future sample collection measurements.

4.2.4.1.1.2 Known Standard Gas Check

Following the canister zero air check in Section 4.2.6.1.1.1, it is *strongly recommended* that canister bias be assessed by filling a cleaned canister with a low-level (0.3 to 2 ppb) humidified standard gas and analyzed 30 days following the initial pressurization. Intermediate timepoints minimally 14 days after pressurization may be added and may indicate a bias problem, eliminating the need to perform the 30-day timepoint analysis. Canisters which meet criteria at intermediate timepoints should be analyzed at the 30-day timepoint to verify they are bias free for the 30-day period. Laboratories may tailor this later timepoint to be representative of the maximum holding time experienced by the laboratory (e.g. 21 days if all samples are analyzed within this time frame from sample collection). The initial analysis should show that target

analytes are within 30% of nominal and not show significant degradation beyond 30% of nominal for subsequent timepoints over the 30-day evaluation period.

While not a substitute for performing canister bias checks, an additional method to assess canister bias is to collect an ambient air sample, analyze it immediately, and analyze it again following an extended period (e.g. 30 days) and look for changes in analyte concentration which exceed 30% from the initial analysis.

4.2.4.2 Canister Cleaning. Cleaning of canisters for ambient sample collection may be performed in a variety of ways which may result in acceptably low background levels in the canister. Systems are commercially available from a variety of manufacturers or may be custom-built. Many incorporate the following elements:

1. Manifold for connection of several canisters (typically 4 to 8)
2. Rough vacuum pump to achieve vacuum of approximately 1 inch Hg
3. High vacuum pump (such as a molecular drag pump) to achieve a final canister vacuum of approximately 50 mTorr or less
4. Heating oven, heating bands, or heating jackets
5. Humidification system
6. Automated switching between evacuation and pressurization
7. A pressure release valve to minimize the likelihood of system overpressurization
8. Trap (cryogenic or molecular sieve) to eliminate backstreaming of contaminants into canisters (only necessary for systems with a non-oil free vacuum pump – note use of such pumps is not recommended)
9. Chromatographic grade stainless steel tubing and connections – recommend minimizing system dead volume to minimize pressurization/evacuation time and provide less surface area for contaminants
10. Source of clean purge gas such as zero air or UHP nitrogen
11. Absence of butyl rubber, Teflon[®], or other materials that may adsorb and/or offgas compounds of interest or other potential interferences

Regardless of how canisters are cleaned, canister cleanliness criteria must be met.

Monitoring agencies must prescribe a policy for holding time for cleaned canisters, which must not exceed 30 days unless objective evidence indicates that the additional time does not negatively impact measured sample concentrations.

4.2.4.2.1 Heated Canister Cleaning. Heating of canisters during cleaning is *strongly recommended*. Various methods of heating canisters during cleaning may be employed. The temperature applied to the canister should depend on whether the canister is silica-lined or electropolished, the temperature rating of the valve and vacuum gauge (if so equipped), and the heating method employed.

Heating bands often cause hot spots on the canister, do not evenly heat canister surfaces further from the bands, and may not adequately heat the valve. Heating jackets and ovens heat the canister evenly, but may not be able to isolate the valve from the heat source, which may cause damage to the valve if cleaning is performed at high heat (> 80°C). Some heating jackets or ovens allow the valve to protrude from the jacket or oven and allow the valve to only be exposed to radiant heat.

If employing humidified HCF zero grade air during canister cleaning (specifically the canister pressurization steps), silica-lined canisters should not be heated above 80°C as oxidation of the surface may occur which leads to active sites within the canister.⁶

Heating is recommended for cleaning of ambient concentration canisters, however higher temperatures are not always better. For canisters of known history used for ambient sample collection, heating to approximately 75°C during cleaning is generally sufficient. Canisters used for collection of source level (part per million) samples or samples with matrices including high molecular weight compounds with high boiling points should be heated to a higher temperature (100°C or higher), if permitted by the canister and valve. Typically such canisters cannot be sufficiently cleaned and should be sequestered from use for collecting ambient samples.

4.2.4.2.2 Cycles of Evacuation and Pressurization. Canisters containing standards or unknown contents with pressures above ambient pressure should be vented into a fume hood or other exhaust outlet prior to connection to the canister cleaning manifold. In general, the greater the number of evacuation and pressurization cycles, the more effective the cleaning. Also, longer holds of vacuum generally result in more effective cleaning. Canisters should be evacuated to > 28 inches Hg vacuum during each evacuation cycle.

While TO-15 recommends three cycles of evacuation and pressurization, minimally five cycles of evacuation and pressurization are recommended and ten or more have been shown to be effective in removing stubborn oxygenated compounds (e.g. acetone, methyl ethyl ketone, and isopropanol).⁷ Following the principle of extraction efficiency where each cycle recovers a specific percentage of each compound (i.e. 85%), additional evacuation and pressurization cycles (up to 20) are highly recommended to achieve sufficiently clean canisters. Vacuum of > 28 inches Hg should be maintained for minimally 5 minutes before the pressurization step. Final evacuation to ≤ 50 mTorr and maintaining this vacuum for minimally 5 minutes is recommended. Longer final vacuum holds up to approximately an hour are recommended if feasible. Automated canister cleaning systems may be advantageous as including additional cycles or extending vacuum hold times can easily be programmed.

An alternative to performing the final evacuation at the end of the cleaning cycles, canisters may be stored pressurized with humidified zero air or other clean purge gas. When stored pressurized, canisters are evacuated to ≤ 50 mTorr just prior to field deployment.

4.2.4.2.3 Gas Source for Canister Cleaning Pressurization. If canisters are heated during cleaning, pressurization of canisters to approximately 5 psig is recommended to avoid rupture of the canister when heat is applied. For canisters which are not heated during cleaning, pressurization up to approximately 30 psia is recommended. The purge gas for canister cleaning

should be high purity zero air or nitrogen. Scrubbing of purge gas with additional hydrocarbon traps, moisture traps, and/or catalytic oxidation may be necessary to obtain sufficiently clean purge gas which should be < 0.2 ppbv or < 3x MDL, whichever is lower. When using zero air as the purge gas, lower temperatures should be maintained during the cleaning process (as compared to temperatures possible with UHP N₂) in order to avoid oxidation of interior canister surfaces. UHP nitrogen may be sourced from cylinders or may be the headspace gas from a liquid nitrogen dewar. Regardless of the purge gas selected, its cleanliness should be verified by analysis to ensure that contaminants are not introduced into the canisters during the cleaning process.

The source gas should be humidified to approximately 30 to 70% as practical, generally higher humidity levels are considered to be more effective. The water assists in removal of polar compounds which may otherwise remain adsorbed to interior canister surfaces. Most commercial canister cleaning systems incorporate a type of humidifier, however these typically do not provide a sufficient level of humidity. Humidification systems may be constructed which incorporate a diptube in deionized water which humidifies by bubbling the purge gas through the deionized water or via an impinger placed above the surface of the water in the humidifying chamber. If a bubbler type humidifier is employed, care should be taken to ensure the downstream pressure is lower than the humidifier upstream pressure to avoid backflow of the water. It is recommended that the RH of the purge gas be measured with a calibrated hygrometer to ensure the desired RH is attained.

4.2.4.2.4 Verification of Canister Cleanliness. Following completion of canister cleaning activities, minimally one canister per batch cleaned must be pressurized to approximately the pressure of field collected samples with humidified purge gas, held minimally overnight, and analyzed to ensure all target compounds are < 3x MDL or < 0.2 ppbv, whichever is lower. Cleanliness criteria must be lowered for agencies which dilute field samples such that the cleanliness criteria are met for undiluted samples. For instance, if a laboratory dilutes all samples by two-fold by addition of gas to the collected sample canister, the cleanliness criteria are not doubled, but are cut in half. A detected concentration of benzene at 0.15 ppbv (assuming 3x MDL is higher) at the instrument would not pass criteria, as the concentration adjusted for dilution is 0.30 ppbv which exceeds the 0.2 ppbv criterion.

Analysis of more than one canister from each batch is highly recommended and should be no less than one out of every ten canisters. A best practice is to survey every canister in a cleaning batch. Following analysis, canisters are re-evacuated to ≤ 50 mTorr. If only a subset of the canisters in the batch is able to be analyzed, the selected canisters should be those which indicated the highest total VOC concentration or the highest single target compound concentration in the previous sample. Other conventions for selecting the batch blank canister include random selection or evaluating high molecular weight compounds or oxygenated compounds which are more difficult to completely remove from canisters.

A composite batch blank sample may be prepared by closing the valve of a chosen canister (which is still under vacuum). The manifold is then pressurized with clean purge gas such that the other connected canisters are pressurized. The chosen batch blank canister is then opened to fill the canister with the composite gas from all of the canisters connected to the manifold.

Actions must be taken to further investigate failure of batch blanks to meet the cleanliness criteria. If each cleaned canister from the batch is surveyed, only those canisters which fail the criteria must be recleaned. If one canister representing the batch fails, either the entire batch can be recleaned (recommended) or two canisters from the batch can be selected and analyzed to confirm the batch does not pass criteria. If both of these canisters pass, only the failing canister must be recleaned, otherwise, the batch must be recleaned. Continued failure of batch blanks may indicate that the manifold or other parts of the system has become contaminated.

4.2.4.3 Canister Maintenance and Preventive Maintenance. Maintenance of canisters involves a combination of preventive actions and best practices related to initial canister qualification, sample collection, cleaning, and general handling.

4.2.4.3.1 Collection of Whole Air Samples into Canisters. Whole air sampling into canisters must be performed with a particulate filter as discussed in Section 4.2.3.3 as once particulates have been drawn into a canister, they are difficult to remove. Particulate residue inside of a canister creates active sites and adsorption sites which may have a detrimental effect on sample compound recovery. Particulates may deposit into canister valves, potentially leading to the damage of the threads and seals, resulting in leaks. Furthermore, general cleaning of canisters does little to remove particulate residue interferences which may be indistinguishable from degradation of the interior surface of the canister. For canisters which cannot be remediated successfully, the canister may require retirement. Alternatively, canister manufacturers offer canister reconditioning services which can restore canisters to brand new condition.

When not connected to a system for cleaning, sample collection or analysis, the canister opening should always be capped with a brass cap to ensure particulates do not deposit into the valve opening. To avoid galling the threads of the connection, the brass cap should be installed finger tight then snugged gently, no more than 1/8 turn with a wrench.

4.2.4.3.2 Overtightening of Valves. The amount of torque required to close a valve depends on the particular type of valve and overtightening will likely damage the valve. Canister valves should never be closed with excessive force or by using a wrench. Damaged valves may not seal appropriately resulting in leaks. Valves with damaged threads or seals should be replaced.

4.2.4.3.3 General Canister Handling. Canisters should be handled with care to ensure that weld integrity is maintained, that the interior canister surface is not compromised, and that the valve-to-canister connection remains intact. Shocks to the surface of the canister may damage welds or create small cracks in the interior canister surface which may expose active sites. Excessive pressure on the canister valve may cause leaks in the seal between the canister valve and canister stem.

Shipment of canisters in protective hard-shell boxes and/or sturdy cardboard boxes is recommended to ensure canister longevity. Care should be taken to replace any boxes which have lost integrity or rigidity.

4.2.5 Method Detection Limits. MDLs for VOCs must be determined minimally annually by following the procedures in Section 4.1. To ensure that the variability of the media is characterized in the MDL procedure, separate spiked canisters (it does not suffice to simply analyze a low-concentration level standard) and method blanks must be prepared, carried out with canisters in use for field collection. It is recommended that canisters are chosen randomly and that each type of canister employed for field sample collection be represented. It is not acceptable to “cherry pick” the best performing canisters for determining MDLs. For example, laboratories determining the MDL following Section 4.1.2.1 must prepare a minimum of seven method blank canisters and a minimum of seven spiked canisters over the course of three different batches (different calendar dates – preferably non-consecutive). These samples must be analyzed in three separate analytical batches (different calendar dates – preferably non-consecutive). The MDL is then determined by calculating the MDL_{sp} and MDL_b and selecting the higher of the two concentrations as the laboratory MDL. Please refer to section 4.1.2 for specific details on selecting a spiking concentration, procedures, and calculations for determining MDLs.

While the MDL capabilities of each laboratory may vary due to a number of factors (canister hygiene, condition of equipment, cleanliness of diluent gases, etc.), spiking concentrations for VOCs MDLs of approximately 0.05 to 0.125 ppbv are typical to achieve the required MDL MQOs.

All steps performed in the preparation and analysis of field sample canisters (such as dilution) must be included in the MDL procedure. Canisters must be prepared at the selected spiking concentration with humidified diluent gas. It is not appropriate to prepare a higher concentration spike and analyze a smaller aliquot than analyzed for field collected samples. For example, for laboratories which analyze 500 mL of field collected sample, a spike concentration of 0.06 ppbv was chosen. The spiked canisters should be prepared at 0.06 ppbv with humidified diluent gas and 500 mL analyzed. It would not be acceptable for the laboratory to prepare spikes at 0.30 ppbv and analyze only 100 mL of the sample as this would not be representative of the procedure for field collected samples.

Note that at very low levels approximating the MDL, the qualitative identification criteria related to qualifier ion abundance ratio and/or signal-to-noise ratio listed in Section 4.2.10.5.3 may not be strictly met when determining the MDL. As the MDL spikes are prepared in a clean matrix with standard materials, the presence of the analyte is expected.

Determined MDLs for Tier I core analytes must meet (be equal to or lower than) those listed in the most current workplan template.

4.2.6 Canister Receipt. When received at the laboratory, canister samples must be accompanied by a COC form. The sample custodian must sign and date the custody form indicating transfer of custody and examine the sample collection documentation. Sample custody is further described in Section 3.3.1.3.7.

Canister pressure for canisters collected to subambient pressure must be measured with a calibrated gauge or pressure transducer when received at the laboratory to ensure that the sample

has not leaked. This is a best practice for canisters collected to pressures above ambient pressure. An acceptable pressure change for subambient pressure samples between the measured pressure at sample retrieval in the field and the pressure upon receipt in the laboratory must be defined in an SOP or similar quality systems document. The recommended tolerance is a pressure change of ≤ 0.5 psia (ensure the measurement is in absolute pressure to account for differences in altitude which contribute to error when measured in psig). Pressurized samples must be measured prior to analysis to ensure that they have not leaked down to atmospheric pressure. Subambient pressure samples which demonstrate pressure changes exceeding criteria should be invalidated.

4.2.7 Dilution of Canisters. Canister samples collected at subambient pressures may require pressurization with HCF zero air or UHP nitrogen to provide sufficient pressure for analysis. When such dilution is performed, the diluent gas must be collected in a separate certified clean canister as a dilution blank (DB) and analyzed to ensure that the dilution process does not contaminate collected samples.

The canister pressure must be measured with a calibrated pressure gauge or pressure transducer just prior to dilution and immediately following dilution. A canister dilution correction factor (CDCF) is calculated from the two absolute pressure readings as follows:

$$\text{CDCF} = \frac{P_d}{P_i}$$

where:

P_d = The pressure of the canister following dilution (psia)

P_i = The pressure of the canister immediately preceding dilution (psia)

Diluted canisters should be allowed to equilibrate minimally overnight, and preferably 24 hours before analysis.

4.2.8 GC/MS Tuning, Calibration, and Analysis

4.2.8.1 Interferences. Moisture in the sample gas may interfere with VOC analysis by GC/MS. Poor water management can cause peak broadening and retention time shifts resulting in peak misidentification, particularly for hydrophilic polar compounds. Carbon dioxide in the collected sample can coelute with more volatile VOCs and interfere with their quantitation. A properly configured moisture management system (as discussed below) can reduce or eliminate the interference of water and carbon dioxide.

Preconcentration systems employ moisture management techniques to eliminate most of the water in the concentrated sample. Instrument manufacturers utilize different methods to manage water removal as well as carbon dioxide such as extended cold trap dehydration (ECTD) or microscale purge and trap (MPT) techniques.

ECTD removes most of the water in the sampled gas by passing the sample gas through an empty first trap cooled to approximately -50°C . This low temperature immediately freezes the

water and allows the VOCs to pass through to a second trap consisting of a weak adsorbent where the VOCs are then trapped. To ensure complete transfer of the VOCs, the first trap is warmed to just above the freezing point of water and a small volume of dry inert gas is employed to sweep any higher boiling point VOCs to the second trap while retaining the water on the first trap.⁸

MPT typically permits a larger amount of water to pass through to the second trap and ultimately to the analytical column than ECTD, potentially resulting in peak broadening and retention time shifts. For MPT, the first trap containing sorbent and/or deactivated glass beads is cooled to approximately -160 to -110°C where all the water and VOCs are retained. The first trap is then heated to several degrees above the freezing point of water and purged with dry inert gas to sweep the VOCs to the second sorbent trap.⁸ The purge of the first trap at a higher temperature may permit more water onto the column compared to ECTD.

Artifacts in chromatograms such as silanol compounds formed from the breakdown of fused silica linings of canisters and siloxane compounds from the breakdown of the stationary phase in an analytical column can interfere with quantitation of less volatile VOCs.

4.2.8.2 Specifications for the Preconcentrator and GC/MS. The analysis instrument must employ detection via mass spectrometer (MS). The MS may be a quadrupole, ion trap, TOF detector. Detection via flame ionization detector (FID) does not permit positive compound identification. Flame ionization detection may be performed by way of splitting the column effluent with the MS and quantitation can be performed from the FID signal. However due to the non-specific nature of FID detectors, analytes must be qualitatively identified via the MS.

Sample introduction and concentration should be handled by an automated cryogenic preconcentration system capable of cooling to as low as -190°C and capable of quantitatively transferring target analytes to the GC column. For cryogenic systems, the target VOCs are isolated from the whole air matrix by passage of the matrix onto a series of traps packed with deactivated glass beads or with a polymer or graphitized sorbent; in some systems, water management is performed by passage of the gas stream through a cryocooled, empty trap. Typically the final step in the cryogenic preconcentration routine is to refocus the VOCs onto another low-volume trap for introduction as a tight band onto the head of the GC column.

The GC should be temperature programmable with cryogenic cooling capabilities. VOCs should be separated with a 60 m by 0.32 mm capillary column with 1 µm lining of 100% dimethylpolysiloxane (e.g., DB-1), or with a column capable of separating the target analytes and ISs so that method performance specifications are attained. The transfer line to the MS should be capable of maintaining 200°C.

The MS detector is operated in electron ionization mode at 70 electron volt (eV) in full scan, SIM, or SIM/scan mode. If operated in full scan or SIM/scan mode, the MS must be capable of completing an entire scan in ≤ 1 second. The MS must be capable of scanning from 45 to 250 atomic mass unit (amu) and producing a mass spectrum of BFB compliant with the ion abundances listed in Table 4.2-2 (for instruments operating in SCAN or SIM/SCAN mode). For laboratories performing analysis of lower molecular weight analytes such as acetonitrile (ACN),

methanol, acetylene, etc., a lower MS scan range capable of 25 to 250 amu may be necessary. Note that the lower scan range often increases the presence of low mass interferences in the chromatogram.

Sample and standard introduction to the preconcentrator is preferably performed via autosampler which allows connection of many canisters that permits unattended analysis of anywhere from four to 16 or more canisters and permits unattended operation. Ports are also typically available on the preconcentrator for internal standard and/or standard introduction.

4.2.8.3 *Standards and Reagents*

4.2.8.3.1 *Calibration Standards.* Stock calibration gases may be procured at concentrations ranging from approximately 50 to 1000 ppb of each target VOC in UHP nitrogen. Target VOCs in this concentration range are generally stable in high pressure passivated cylinders for at least one year, although some vendors certify their mixtures for longer time periods. Calibration gases should be recertified by the supplier or third party annually unless a longer expiration period is assigned by the supplier. Alternatively, a new stock standard or set of stock standard gases may be procured; however, this is typically several-fold more expensive than recertification. Dilution of the stock calibration gas by approximately 400-fold permits preparation of working range calibration standards in canisters at single digit ppb concentrations.

Off-the-shelf stock mixes are available containing approximately 65 target VOCs including the NATTS core VOCs at 1 ppm, and gas mixtures with tailored compound lists and concentrations are available as custom orders from certain suppliers. It may be necessary to procure multiple stock gases to acquire all desired VOCs.

Calibration stock gases must be purchased from a supplier that provides a COA stating each target VOC's concentration with associated uncertainty. An expiration must be assigned to each standard gas mixture. Uncertainty of the certified concentrations must be specified as within no more than $\pm 10\%$.

4.2.8.3.2 *Secondary Source Calibration Standards.* Secondary source stock calibration gases must be procured from a separate supplier and meet the criteria listed above in Section 4.2.10.3.1. A standard prepared with a different lot of source material from the same supplier as the primary calibration stock is only acceptable if it is unavailable from another supplier. As with the calibration stock gases, the secondary source stock must be recertified annually.

4.2.8.3.3 *Internal Standards.* IS gases should be procured including a minimum of three VOCs covering the early, middle, and late elution range of the target VOC elution order. At minimum a single IS compound must be used. ISs must either be deuterated VOCs or VOCs which behave chromatographically similarly to, but are not, target VOCs. Three typical VOCs internal standards are 1,4-difluorobenzene, chlorobenzene- d_5 , and bromochloromethane.

IS stock gases are commercially available at 100 ppb in UHP nitrogen, or may be purchased with a custom suite of compounds at desired concentrations. IS stock gases should be evaluated upon

receipt for the presence of contaminants. Compounds whose response increases with an increasing volume of IS analyzed are present in the IS mixture. IS gas standards which contribute unacceptable levels of target VOCs, such that, for instance, system blanks fail acceptance criteria, must not be employed for analysis and must be replaced. Typical contaminants in IS mixtures include methylene chloride and carbon disulfide.

The IS must be added to and analyzed with each injection at the same concentration in order to monitor instrument sensitivity and assess potential matrix effects. ISs are not added directly to the sample canister, rather they are introduced through a different dedicated non-sample port in the preconcentrator and trapped along with the sample aliquot on the first trapping module in the preconcentrator. The concentration of IS added to each injection should be chosen such that the IS compounds provide a peak which is onscale and approximates the area response of the highest calibration standard.

4.2.8.3.4 Diluent Gases. Diluent gases may consist of zero air or UHP nitrogen. Zero air is typically sourced from a zero air generator and may be further scrubbed by treatment with activated carbon scrubbers or oxidizers. Zero air is also commercially available in cylinders, however may be cost prohibitive to procure meeting cleanliness specifications or may require further cleanup to remove impurities which affect analysis. Nitrogen gas must be from an UHP source (purity $\geq 99.999\%$) or from the headspace of a liquid nitrogen dewar. Regardless of which gas is chosen as a diluent, it must be analyzed to demonstrate to verify that levels of target VOCs are acceptably low ($\leq 3x$ MDL or 0.2 ppb, whichever is lower). For diluent gas contained within a cylinder or from discrete liquid nitrogen tanks, the gas must be analyzed prior to preparing dilutions with the gas. For zero air generators or replenished onsite fixed liquid nitrogen Dewars, the diluent gas must be analyzed monthly.

4.2.8.3.5 MS Tuning Standard – BFB. 4-bromofluorobenzene (BFB) may be purchased as a standalone gas at approximately 30 to 100 ppb in UHP nitrogen or may be purchased as a component in the IS mixture.

4.2.8.3.6 Reagent Water for Humidification of Gases. Reagent water for humidification of gases must be ASTM Type I ($\geq 18 \text{ M}\Omega \cdot \text{cm}$). Additional purifying steps, such as sonication, helium sparging, or boiling may be necessary to reduce or eliminate dissolved gases potentially present in the water.

Humidification is most efficiently performed by bubbling the gas to be humidified through a bubbler via a diptube submerged in the reagent water or passing the gas across the surface of the reagent water via an impinger. Analysts should be aware of the potential for water to enter the bubbler tube and be sucked into the gas supply tubing if the pressure downstream of the bubbler becomes greater than the upstream pressure. Passing of the gas to be humidified through the headspace of a vessel containing water typically achieves a RH of 20 to 30%, which is insufficient to maintain the desired RH level of approximately 50% for serving as a diluent gas in standards preparation or as a humidified blank. Laboratories should measure the RH of the resulting humidified gas stream to ensure it reaches approximately 50%. If this RH level cannot be reached with an inline humidification system, liquid water should be added to the canister. Approximately 75 μL of deionized water can be added to the canister to increase the RH to

approximately 40-50% at room temperature and 30 psia. Adding water to canisters with a syringe via rubber septum is not recommended, as the syringe needle can core the septum resulting in deposits of rubber into the canister and valve, leading to later bias problems with the canister. For direct injection of water into a canister with a syringe, a high pressure Teflon sealed septum (such as a Merlin Microseal®) should be installed on the canister. For canisters which are connected to a gas source for pressurization via a dynamic or static dilution system, the water can be added to the valve opening prior to connecting the outlet tubing. Once the tubing is connected, the valve is opened and the water is pulled into the canister along with the diluted standard gas.

4.2.8.4 Preparation of Calibration Standards and Quality Control Samples

4.2.8.4.1 Calibration Standards. Working calibration standards are typically prepared by diluting the calibration stock gas with humidified zero air by dynamic dilution or calibrated automated static dilution. In these types of dilution, flows of the stock gas(es) and diluent gas are carefully metered and the gases may be blended in a mixing chamber to ensure complete mixing. Such systems are commercially available which permit the mixing of multiple standard gases with a diluent gas. The homogenous, diluted gas mixture is then collected into a cleaned canister. Working level concentrations are tailored to provide standards covering approximately 0.1 to 5 ppb.

Calibration standard canisters may be prepared according to two conventions for calibrating the GC/MS. The first convention consists of preparing a separate canister for each calibration concentration level such that a total of five different calibration standard canisters are prepared to establish the calibration curve with the required minimum five points. For this procedure, the same volume is analyzed from each canister to establish the calibration curve. The second convention consists of preparing two separate canisters at a low and high concentration. Different volumes of each of the two canisters are analyzed to prepare the five-point calibration curve. It is also acceptable to prepare the calibration curve by injecting different volumes from a single canister provided the calibration curve is verified with an independent second source quality control standard.

MFCs in dynamic dilution systems must be calibrated initially and the calibration verified minimally quarterly. Mass flow controllers which fail the calibration check criterion of 2% must be calibrated. Removal of the MFC from the dynamic dilution system to be calibrated by the manufacturer is inconvenient and expensive. Instead, a regression calibration can be generated by challenging the MFC with gas and recording the MFC setting and measuring the flow with a flow calibrator for a minimum of five points covering the 10% to 100% of the flow range of the MFC. The resulting regression slope and intercept is then employed to provide the MFC setting for a given desired flow.

Dynamic dilution systems should be powered on and diluent and stock gases flowing through the MFCs for minimally one hour prior to use. Warm-up flows should be the desired settings necessary to prepare the working calibration standards. This warm-up period allows passivation and equilibration of gases to ensure the concentration of the blended gas is stable prior to transferring to the canister. When changing stock gas flow rate to prepare a different

concentration, calibration gas should flow through the system for a minimum of 30 minutes prior to preparation of the working calibration canister. These warm-up and equilibration times are particularly important for laboratories analyzing compounds with higher boiling points such as hexachlorobutadiene and 1,2,4-trichlorobenzene. Extended equilibration times may be necessary to fully passivate the flow path and mixing chamber of the dynamic dilution system when these compounds are desired.

Note that final pressures of calibration standard canisters must not exceed the maximum pressure permitted by the preconcentrator unit. Closely matching the pressure of the calibration standard canisters to the expected pressure of the collected field samples is recommended when analysis is performed with preconcentrators that measure volumes with MFCs. Consult the preconcentrator instrument manual for further guidance on matching canister pressures.

The preferred procedure for preparing calibration standards is dynamic dilution; however, static dilution by way of syringe injection of calibration stock gases may also be employed. Syringe dilution requires excellent technique to accurately and reproducibly prepare calibration standards.

Calibration standard canisters must be humidified to approximately 50% RH by either humidifying the diluent or by addition of liquid water to the canister. For diluent gases which are humidified to approximately 25% RH, approximately 100 μ L of reagent water should be added to the canister prior to pressurization with standard gas to approximately 30 psia. For standard canisters prepared at lower pressures, a smaller volume of water should be added. Standard canisters must be allowed to equilibrate minimally overnight (recommended 24 hours) before analysis.

4.2.8.4.2 *Second Source Calibration Verification Sample.* A second source calibration verification (SSCV) is prepared in a canister at approximately the mid-range of the calibration curve by dilution of the secondary source stock standard. The SSCV verifies the accuracy of the calibration curve. The SSCV must minimally contain all Tier I core compounds and it is recommended that the SSCV also contain at least one compound representative of each type of compound in the calibration (e.g. low molecular weight, chlorinated, fluorinated, brominated, high molecular weight, etc.). It is strongly recommended that the SSCV contain all compounds in the calibration mix.

4.2.8.4.3 *Method Blank.* The MB canister is prepared by filling a cleaned canister with humidified diluent gas. For laboratories using a dilution system (dynamic or automated static), the method blank should be pressurized with the dilution system. The MB verifies the diluent gas is sufficiently clean. To best represent canisters which are sent to the field for sample collection, the MB should be prepared in a clean canister which was verified by batch blank analysis. Analysis of a canister cleaning batch blank as the MB complicates the corrective action process to locate the source if the MB canister analysis indicates contamination.

4.2.8.4.4 *Laboratory Control Sample.* The LCS is prepared at approximately the lower third of the calibration range by dilution of the calibration stock gas. While not required, preparation and analysis of the LCS is recommended. The LCS may serve as the CCV and the

volume of LCS analyzed should be the same volume as that taken from sample canisters for routine analysis. The LCS serves to both verify that calibration standards were prepared correctly and that the instrument remains in calibration.

4.2.8.5 Analysis via GC/MS

4.2.8.5.1 Tuning of the MS. Prior to initial calibration and every 24 hours of analysis thereafter, the MS tune of quadrupole MS detectors must be verified to meet the abundance criteria in Table 4.2-2 by injection and analysis of approximately 50 ng of BFB when operating in SCAN or simultaneous SIM/SCAN mode.

Failure to meet the BFB tuning criteria requires corrective action which may include adjusting MS tune parameters or cleaning of the ion source. The instrument must be recalibrated following adjustments or maintenance which impacts the MS tune.

To the extent possible for ion trap and TOF MS detectors, tune the MS such that the m/z abundance sensitivities are maximized for the lower mass range, m/z < 150. TOF and ion traps should be tuned per the manufacturer specifications.

Table 4.2-2. Required BFB Key Ions and Ion Abundance Criteria

Mass (m/z)	Ion Abundance Criteria *
50	8.0 to 40.0% of m/z 95
75	30.0 to 66.0% of m/z 95
95	Base peak, 100% relative abundance
96	5.0 to 9.0% of m/z 95 (see note)
173	Less than 2.0% of m/z 174
174	50.0 to 120.0% of m/z 95
175	4.0 to 9.0% of m/z 174
176	93.0 to 101.0 of m/z 174
177	5.0 to 9.0% of m/z 176

* All abundances must be normalized to m/z 95, the nominal base peak, even though the ion abundance of m/z 174 may be up to 120% of m/z 95.

4.2.8.5.2 Leak Check and Calibration of the GC/MS

4.2.8.5.2.1 Leak Check

Prior to beginning an analytical sequence, including an initial calibration (ICAL) sequence, each canister connection must be verified as leak-free through the preconcentrator. During the leak check, canisters are connected to the autosampler or sample introduction lines and the canister valves are kept closed. Each port of the autosampler or sample introduction line is evacuated and the pressure monitored over 30 seconds or 1 minute for a change in pressure. Connections

which show a pressure change of > 0.2 psi/minute or exceed manufacturer criteria must be corrected by tightening the fittings. Leak check criteria in automated leak check routines should be equivalent to or better than those listed above and should be prescribed in the analysis SOP. Analysis must not be performed on any canister connection which does not pass the leak check. Canisters which do not pass leak check may leak to atmospheric pressure allowing laboratory air into the analyzed sample stream. Many preconcentration control software systems include a leak check function which provides standard QC reports. Following the leak check all autosampler ports or sample introduction lines are evacuated and the canister valves are opened. Leak checks must be documented in the analysis records.

4.2.8.5.2.2 Initial Calibration of the GC/MS

The GC/MS instrument must be calibrated initially, following failure of CCV checks, and following adjustments or maintenance which impact the performance of the GC/MS system including, but not limited to: cleaning of the ion source, trimming or replacing the capillary column, or adjustment of MS tune parameters.

The MS must meet BFB tune criteria listed in Section 4.2.10.5.1 before calibration may begin. An instrument blank (IB) is recommended to be analyzed prior to analysis of calibration standards to demonstrate the instrument is free of target VOCs and potential interferences. The IB is an injection of carrier gas taken through the preconcentration steps without introduction of sample gas into the preconcentrator. Analysis of the IB must show all target compounds are < 3x MDL or < 0.2 ppb, whichever is lower.

The ICAL curve is prepared by analysis of different concentration levels covering approximately 0.03 to 5 ppbv. At minimum five levels must be included in the ICAL and more are recommended, especially in the lower end of the calibration curve if the lowest standard concentration is in the tens of pptv. Calibration curves may be established on the instrument by two conventions. The first convention is to prepare a separate canister for each level of the calibration curve and inject the same volume from each canister. The second convention involves preparation of one to three canisters at different concentrations from which different volumes are analyzed to establish the calibration curve. An example of this second convention with two separate canisters follows:

For a typical analysis volume of 400 mL, an eight-point calibration curve is constructed utilizing two standard canisters prepared at 0.25 ppbv and 5.0 ppbv. The curve is established at 0.03, 0.05, 0.075, 0.1, 0.25, 0.75, 1.5, and 5.0 ppb by analysis of 48, 80, 120, 160, and 400 mL from the 0.25 ppb canister and analysis of 60, 120 and 400 mL from the 5.0 ppb canister.

For measuring low (tens of pptv) levels of VOCs as is needed for ambient air analysis, it is important to characterize the lower end of the calibration curve by loading the number of calibration points toward the bottom of the curve (as shown in the example above). Including more points in the lower end of the curve minimizes calibration error at the low end of the curve as the upper end of the curve has an outsized influence on the curve model when calibration levels are evenly distributed across the calibration range.

When the second calibration convention is utilized (analyzing different volumes out of one to three canisters), checking the calibration of the MFC quarterly is recommended to ensure accurate volumes are metered for analysis.

Following analysis of all calibration standards, a calibration curve is prepared for each target analyte by determining the relative response factor of each concentration level. Following data acquisition for the calibration standards, the relative response factor (RRF) of each target compound in each calibration level is determined as follows:

$$\text{RRF} = \frac{A_s \cdot C_{IS}}{A_{IS} \cdot C_s}$$

where:

A_s = peak area for quantitation ion of the target compound

A_{IS} = peak area for quantitation ion of the assigned internal standard compound

C_s = concentration of the target compound

C_{IS} = concentration of the assigned internal standard compound

If the method of RRFs is selected for construction of the calibration curve, the relative standard deviation (RSD) of the RRFs for each Tier I Core target VOC must be $\leq 30\%$ and all other compounds should meet this specification. For Tier II compounds which do not meet this criterion, results should be qualified when reported to AQS. Alternatively, a calibration curve may be prepared by linear or quadratic regression of the ratios A_s/A_{IS} as the dependent variables and the ratios C_s/C_{IS} as the independent variables. The correlation coefficient for linear or quadratic curves must be ≥ 0.995 for target VOCs. Irrespective of the curve fit method selected, the calculated concentration for each VOC at each calibration level must be within 30% of the nominal concentration when quantitated against the resulting calibration curve. Exclusion of calibration standard levels is not permitted unless justifiable (for example, a known error in standard preparation). Sample analysis must not be performed, and if performed, results must not be reported when calibration acceptance criteria are not met for Tier I core analytes. Rather, corrective action, possibly including recalibration, must be taken.

Relative retention times (RRTs) are calculated for each concentration level of each target compound by dividing the target compound retention time (RT) by the associated IS compound RT. The RRTs of each target compound are then averaged to determine the mean RRT ($\overline{\text{RRT}}$) of the ICAL. RRT at each concentration level must be within ± 0.06 RRT units of $\overline{\text{RRT}}$.

4.2.8.5.2.3 Secondary Source Calibration Verification

Following each successful initial calibration, a SSCV standard must be analyzed to verify the ICAL. Each target VOC in the SSCV must recover within $\pm 30\%$ of nominal or the RRF must be within $\pm 30\%$ of the mean ICAL RRF. Periodic reanalysis of the SSCV is recommended once the ICAL has been established.

4.2.8.5.2.4 Continuing Calibration Verification

Once the GC/MS instrument has met tuning and calibration criteria, a CCV must be analyzed after every 24 hours of analysis immediately following the BFB tune check and is recommended to be analyzed after every ten sample injections and at the end of each analytical sequence. Each target VOC's concentration in the CCV must be within $\pm 30\%$ of nominal or the RRF must be within 30% of the average RRF from the ICAL. Corrective action must be taken to address CCV failures, including, but not limited to, preparing and analyzing a new CCV, trimming or replacing the column, retuning the MS, or preparing a new ICAL.

4.2.8.5.2.5 Analysis of Laboratory QC Samples and Field Samples

The following laboratory QC samples are required with each analysis batch containing 20 or fewer field-collected canisters:

- MB
- Replicate sample analysis

Each target VOC's concentration in the MBs must be $< 3x$ MDL or < 0.2 ppb, whichever is lower. The precision of the replicate analysis must be such that $\leq 25\%$ RPD is achieved for each target VOC having a concentration $> 5x$ MDL. Samples should be reanalyzed to confirm the out of criteria result(s) and if confirmed, should be a trigger for corrective action. Sample data associated with these failures must be qualified appropriately when reported to AQS.

An LCS is recommended to be analyzed with each analysis batch, and must recover within 70 to 130%.

4.2.8.5.3 Compound Identification. Four criteria must be met in order to positively qualitatively identify a target compound:

1. The signal-to-noise ratio of the target and qualifier ions must be $> 3:1$, preferably $> 5:1$.
2. The target and qualifier ion peaks must be co-maximized (peak apexes within one scan of each other).⁹
3. The RT of the compound must be within the RT window as determined from the ICAL average.
4. The abundance ratio of the qualifier ion response to target ion response for at least one qualifier ion must be within $\pm 30\%$ of the average ratio from the ICAL.

Please refer to Figure 4.2-2 for an example of the qualitative identification criteria listed above and the following discussion. The RT is within the retention time window defined by the method (red box A), and the abundance ratios of the qualifier ions are within 30% of the ICAL average ratio (red box B). The signal-to-noise ratio of the peak is shown to be greater than 5:1 (red oval C) and the target and qualifier ion peaks are co-maximized (dotted purple line D).

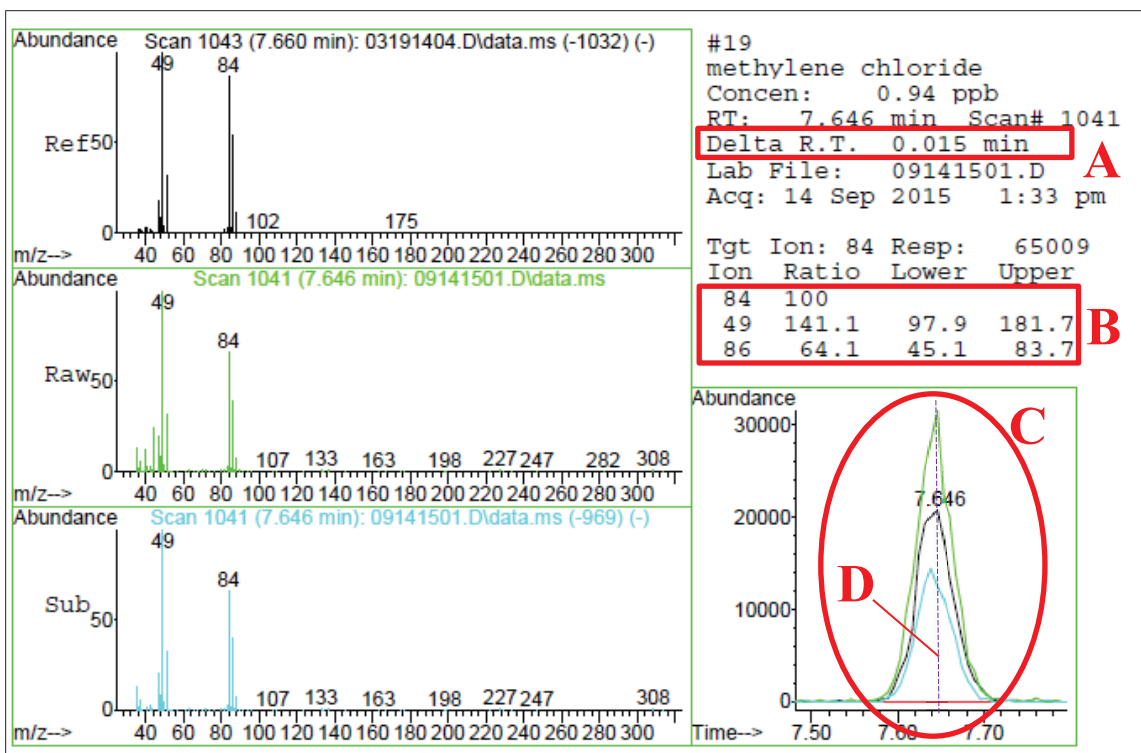

Figure 4.2-2. Qualitative Identification of GC/MS Target Analytes

Please refer to Figure 4.2-3 for the following example for determining the signal-to-noise ratio. To determine signal-to-noise, the characteristic height of the noise of the baseline (A) just before the peak and the height of the analyte peak (B) are measured. The ratio of the analyte peak height (B) is divided by the noise height (A) to calculate the S:N ratio. In the example below, the peak at 17.0 minutes is discernable from the noise, but is not well-resolved and is very close to a S:N of 3. In the example, the peak heights of the noise and analyte peak (at approximately 17.0 minutes) are approximately 700 units and 1700 units, respectively, for a S:N of 2.4.

Determination of the S:N is somewhat subjective based on the individual analyst and their characterization of the noise and analyte peak. Some chromatography systems include S:N functions which require the analyst to assign the noise and target peak. For well-resolved peaks, the S:N will greatly exceed 5:1, and does not need to be measured. For peaks with low S:N that are questionable as to whether they meet the criteria in item #1 above, the 3:1 S:N criterion is a guideline; it is unnecessary to measure each peak, rather the experienced analyst's opinion should weigh heavily on whether the peak meets the S:N criterion.

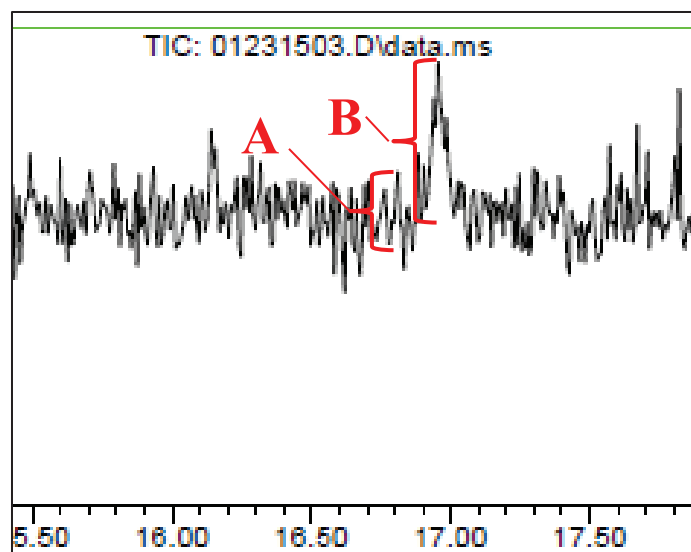

Figure 4.2-3. Determination of Chromatographic Peak Signal-to-Noise Ratio

As with the S:N determination, evaluation of whether target and qualifier ion peaks are co-maximized does not need to be rigorously evaluated with each peak. Rather the interpretation of the experienced analyst should weigh heavily on whether the qualifier ion peaks are co-maximized with the target ion. Items 3 (retention time) and 4 (relative ion abundances) above may be automated by the analysis software such that they are automatically flagged. It is important that the RT windows and ion abundances be updated with each new ICAL.

If any of these criteria are not met, the compound may not be positively identified. The only exception to this is when in the opinion of an experienced analyst the compound is positively identified. The rationale for such an exception must be documented.

4.2.8.5.4 Internal Standards Response. The response of the ISs must be monitored for each injection (except for the instrument blank immediately preceding the ICAL or daily CCV). Area responses of each IS must be within $\pm 40\%$ of its mean area response in the five-point ICAL. Each IS must elute within 0.33 minutes of its average RT from the five-point ICAL.

Note: Comparing the IS response to the most recent CCV is not appropriate as this permits the IS response to drift by as much as 64% from the five-point ICAL before corrective action is necessary. For example, if the average IS response in the ICAL is 10000 area counts, the CCV IS response may decrease to as low as 6000 area counts (a decrease of -40% from the five-point ICAL average) and still meet criteria. Comparing sample IS response to this CCV permits the IS to drift as low as 3600 area counts (a decrease of -40% from the CCV response), a drift of -64% from the five-point ICAL average IS response.

The IS response tends to decrease over time as the MS ion optics age and become dirty. If an IS response is nonconformant and appears to be isolated to a specific sample, the possibility of a matrix interference should be investigated by analysis of a smaller volume of the air sample. If an IS response in the dilution remains nonconformant, corrective action should be taken which

may include investigating problems with the preconcentrator, autosampler, or other parts of the sample introduction path. The MS tune should also be evaluated for a degradation or enhancement of sensitivity.

4.2.9 Data Review and Concentration Calculations. Each chromatogram must be closely examined to ensure chromatographic peaks are appropriately resolved and integration does not include peak shoulders or inflections indicative of a coelution.

The concentrations of target compounds detected in the analyzed aliquot are quantitated by relating the area response ratio of the target compound and assigned IS in the unknown sample to the average RRF (\overline{RRF}) of the initial calibration curve as follows:

$$C_D = \frac{A_t \cdot C_{IS}}{A_{IS} \cdot \overline{RRF}}$$

where:

C_D = instrument detected analyte concentration (ppb)
 A_t = area response of the target compound quantitation ion
 C_{IS} = concentration of assigned internal standard (ppb)
 A_{IS} = area response of the assigned internal standard quantitation ion
 \overline{RRF} = average relative response factor from the initial calibration

If a smaller aliquot was analyzed from the sample canister than the typical analysis volume, an instrument dilution correction factor (IDCF) must be calculated:

$$DCF = \frac{V_{nom}}{V_{inj}}$$

where:

V_{nom} = nominal volume of sample injected (typical volume analyzed)
 V_{inj} = reduced volume of the sample injected

The final in air concentration (C_F) of each target compound is determined by multiplying the instrument detected concentration by the canister dilution correction factor and the instrument dilution correction factor:

$$C_F = C_D \cdot CDC \cdot DC$$

where:

C_F = concentration of the target compound in air (ppb)
 $CDCF$ = canister dilution correction factor
 $IDCF$ = instrument dilution correction factor

MDLs reported with the final concentration data must be corrected by multiplying the MDL by the canister and instrument dilution correction factors applied to the sample concentrations. For example, if the benzene MDL is 0.0091 ppbv for an undiluted sample and the sample was diluted by 2.5, the MDL becomes 0.023 ppbv.

4.2.10 Summary of Quality Control Parameters. A summary of QC parameters is shown in Table 4.2-3.

Table 4.2-3. Summary of Quality Control Parameters for NATTS VOCs Analysis

Parameter	Description and Details	Required Frequency	Acceptance Criteria
Instrument Blank (IB)	Analysis of swept carrier gas through the preconcentrator to demonstrate the instrument is sufficiently clean to begin analysis	Prior to ICAL and daily beginning CCV	Each target VOC's concentration < 3x MDL or 0.2 ppb, whichever is lower
BFB Tune Check	50 ng injection of BFB for tune verification of quadrupole MS detector	Prior to initial calibration and every 24 hours of analysis thereafter	Abundance criteria listed in Table 4.2-2
Initial Calibration (ICAL)	Analysis of a minimum of five calibration levels covering approximately 0.1 to 5 ppb	Initially, following failed BFB tune check, failed CCV, or when changes/maintenance to the instrument affect calibration response	Average RRF \leq 30% RSD and each calibration level must be within \pm 30% of nominal For quadratic or linear curves, $r \geq 0.995$, each calibration level must be within \pm 30% of nominal
Secondary Source Calibration Verification (SSCV)	Analysis of a secondary source standard at the mid-range of the calibration curve to verify ICAL accuracy	Immediately after each ICAL	Recovery within \pm 30% of nominal or RRF within \pm 30% of the mean ICAL RRF
Continuing Calibration Verification (CCV)	Analysis of a known standard at the mid-range of the calibration curve to verify ongoing instrument calibration	Following each daily BFB tune check and every 24 hours of analysis; recommended after each ten sample injections and to conclude each sequence	Recovery within \pm 30% of nominal or RRF within \pm 30% of the mean ICAL RRF
Canister Cleaning Batch Blank	A canister selected for analysis from a given batch of clean canisters to ensure acceptable background levels in the batch of cleaned canisters	One canister from each batch of cleaned canisters – Canister chosen must represent no more than 10 total canisters.	Each target VOC's concentration < 3x MDL or 0.2 ppb, whichever is lower (All Tier I Core analytes must meet this criterion)
Internal Standards (IS)	Deuterated or not naturally occurring compounds co-analyzed with samples to monitor instrument response and assess matrix effects	Added to all calibration standards, QC samples, and field-collected samples	Area response for each IS compound within \pm 40% of the average response of the ICAL
Preconcentrator Leak Check	Pressurizing or evacuating the canister connection to verify as leak-free	Each standard and sample canister connected to the instrument	< 0.2 psi change/minute or manufacturer recommendations

Table 4.2-3. Summary of Quality Control Parameters for NATTS VOCs Analysis (Continued)

Parameter	Description and Details	Required Frequency	Acceptance Criteria
Method Blank (MB)	Canister filled with clean diluent gas	One with every analysis batch of 20 or fewer field-collected samples	Each target VOC's concentration < 3x MDL or 0.2 ppb, whichever is lower
Laboratory Control Sample (LCS)	Canister spiked with known amount of target analyte at approximately the lower third of the calibration curve	(Recommended) One with every analysis batch of 20 or fewer field-collected samples	Each target VOC's recovery must be 70 to 130% of its nominal spiked amount
Duplicate Sample	Field sample collected through the same inlet probe as the primary sample	10% of primary samples for sites performing duplicate sample collection (as prescribed in workplan)	Precision \leq 25% RPD of primary sample for concentrations \geq 5x MDL
Collocated Sample	Field sample collected through a separate inlet probe from the primary sample	10% of primary samples for sites performing collocated sample collection (as prescribed in workplan)	Precision \leq 25% RPD of primary sample for concentrations \geq 5x MDL
Replicate Analysis	Replicate analysis of a field-collected sample (chosen by analyst)	Once with every analysis sequence (as prescribed in workplan)	Precision \leq 25% RPD for target VOCs with concentrations \geq 5x MDL
Retention Time (RT)	RT of each target compound and internal standard	All qualitatively identified compounds and internal standards	Target VOCs within \pm 0.06 RRT units of mean ICAL RRT IS compounds within \pm 0.33 minutes of the mean ICAL RT

4.2.11 References

1. Spicer, C. W., S. M. Gordon, et al. (2002). Hazardous Air Pollutants Handbook: Measurement, Properties, and Fate in Ambient Air. Boca Raton, Lewis Publishers.
2. *Determination of Volatile Organic Compounds (VOCs) in Air Collected in Specially Prepared Canisters and Analyzed by Gas Chromatography/Mass Spectrometry (GC/MS)*; EPA Compendium Method TO-15; U.S. Environmental Protection Agency: 1999. Available at (accessed October 19, 2016): <https://www3.epa.gov/ttnamti1/files/ambient/airtox/to-15r.pdf>
3. Standard Operating Procedures for the Determination of Acrolein and other Volatile Organic Compounds (VOCs) in Air Collected in Canisters and Analyzed by Gas Chromatography/Mass Spectrometry (GC/MS), U.S. Environmental Protection Agency, Office of Air Quality Planning & Standards, Research Triangle Park, NC, November 2006.
4. Herrington, J.S.: Storage Stability of 66 Volatile Organic Compounds (VOCs) in Silicon-Lined Air Canisters for 30 Days. Literature Catalog # EVAN2066-UNV, Restek Corporation. 2015. Available at (accessed October 19, 2016): <http://www.restek.com/pdfs/EVAN2066-UNV.pdf>
5. McClenny, W.A.; Schmidt, S.M.; Kronmiller, K.G. Variation of the Relative Humidity of Air Released from Canisters After Ambient Sampling. In *Proceedings of the Measurement of Toxic and Related Air Pollutants International Symposium*, Research Triangle Park, NC, 1997.
6. Restek Technical Guide: "A Guide to Whole Air Canister Sampling. Equipment Needed and Practical Techniques for Collecting Air Samples." Literature Catalog # EVTG1073A. Available at (accessed October 19, 2016): <http://www.restek.com/pdfs/EVTG1073A.pdf>
7. EPA NATTS Proficiency Testing Results Calendar Year 2016 Quarter 1 – Referee Results from EPA Region V
8. Entech Application Guide: "3-Stage Preconcentration is Superior for TO-14A and TO-15 Air Methods." August 25, 2015. Available at (accessed October 19, 2016): <http://www.entechinst.com/3-stage-preconcentration-is-superior-for-to-14a-and-to-15-air-methods/#>
9. *Identification and Confirmation of Chemical Residues in Food by Chromatography-mass Spectrometry and Other Techniques*. Lehotay, S.J., et al, TrAC Trends in Analytical Chemistry. December 2008. pp. 1070-1090

4.3 Carbonyl Compounds via EPA Compendium Method TO-11A

Each agency must codify in an appropriate quality systems document, such as an SOP, or equivalent, its procedures for collection of airborne carbonyls onto cartridges, extraction of the cartridges, and analysis of the extracts. Various requirements and best practices for such are given in this section. Note that regardless of the specific procedures adopted, method performance specifications as given in Section 4.3.10 must be met.

4.3.1 General Description of Sampling Method and Analytical Method. Carbonyl compounds such as aldehydes and ketones may be collected and analyzed via EPA Compendium Method TO-11A. The atmosphere to be characterized is drawn at a known flow rate for a known duration of time through an ozone denuder and through a sorbent cartridge coated with DNPH, where the carbonyl compounds react with the DNPH and are derivatized to form carbonyl-hydrazones. These carbonyl-hydrazones are solids at typical ambient temperatures and are retained on the cartridge sorbent bed until eluted with acetonitrile (ACN). Eluted extracts are analyzed by HPLC with a UV detector at a wavelength 360 nm.¹

The carbonyls including, but not limited to, those in Table 4.3-1 may be determined by this method.

Table 4.3-1. Carbonyl Target Compounds and Associated Chemical Abstract Service (CAS) Number via Method TO-11A

Target Carbonyl	CAS #
acetaldehyde ^{a b}	75-07-0
acetone	67-64-1
benzaldehyde ^b	100-52-7
butyraldehyde	123-72-8
crotonaldehyde	4170-30-3
2,5-dimethylbenzaldehyde	5779-94-2
formaldehyde ^{a b}	50-00-0
heptaldehyde	111-71-7
hexaldehyde	66-25-1
isovaleraldehyde	590-86-3
m&p-tolualdehyde	(m) 620-23-5/(p) 104-87-0
methyl ethyl ketone	78-93-3
methyl isobutyl ketone	108-10-1
o-tolualdehyde	529-20-4
propionaldehyde ^b	123-38-6
valeraldehyde	110-62-3

^a NATTS required core analytes

^b NATTS PT analytes

4.3.2 Minimizing Bias. The sampling of airborne carbonyls onto DNPH cartridges is potentially affected by a variety of interferences. For example, nitrogen oxides react with the DNPH derivative to form compounds which may coelute with carbonyl-hydrazone derivatives. Moreover, ozone reacts with DNPH to form possible coeluting interferences and also reacts with and causes negative bias in the measurement of various carbonyl-hydrazones. (More information on ozone management is given in Section 4.3.4.) To minimize introduction of

contamination and to keep bias to a minimum, manage ozone per Section 4.3.4 and handle cartridges as in Section 4.3.5.2. Clean labware and select high-purity reagents as in Section 4.3.9.

The cartridge inlet and outlet caps must be installed when the cartridge is not in use so as to isolate it from the ambient atmosphere where carbonyl compounds and interfering compounds may be passively sampled. Further, cartridges must be stored sealed in the foil pouch or similar opaque container, as light may degrade the DNPH derivatives. Finally, DNPH cartridges must be stored at $\leq 4^{\circ}\text{C}$ after sampling as such slows the reaction of contaminants. Cartridges should only be handled while wearing powder-free nitrile or vinyl gloves.

4.3.3 Carbonyls Precision

4.3.3.1 Sampling Precision. Depending on the configuration of the sampling unit or units at the monitoring site, sampling precision may be assessed by way of the collection and analysis of collocated or duplicate cartridges. Sampling precision is a measure of the reproducibility in the sampling, handling, extraction, and analysis procedures. Monitoring agencies are encouraged to collect collocated and duplicate samples. For monitoring agencies collecting collocated and/or duplicate samples (as detailed in each site's workplan), they must be collected at a minimum frequency of 10% of primary samples.

4.3.3.1.1 Collocated Sample Collection. A collocated sample is a sample for which air is drawn through a co-collected cartridge from an independent inlet probe via a separate discrete sampling unit. If two cartridges are collected together with a single sampling instrument, to be collocated the air passing onto each cartridge must flow through wholly separate channels, where each channel must have a discrete inlet probe, plumbing, pump, and flow controller such as an MFC or rotameter. For sites which employ a manifold inlet to which one or more carbonyl sampling unit inlets is connected, samples co-collected with the primary sample will be designated as duplicate, as shown in Figure 4.3-1.

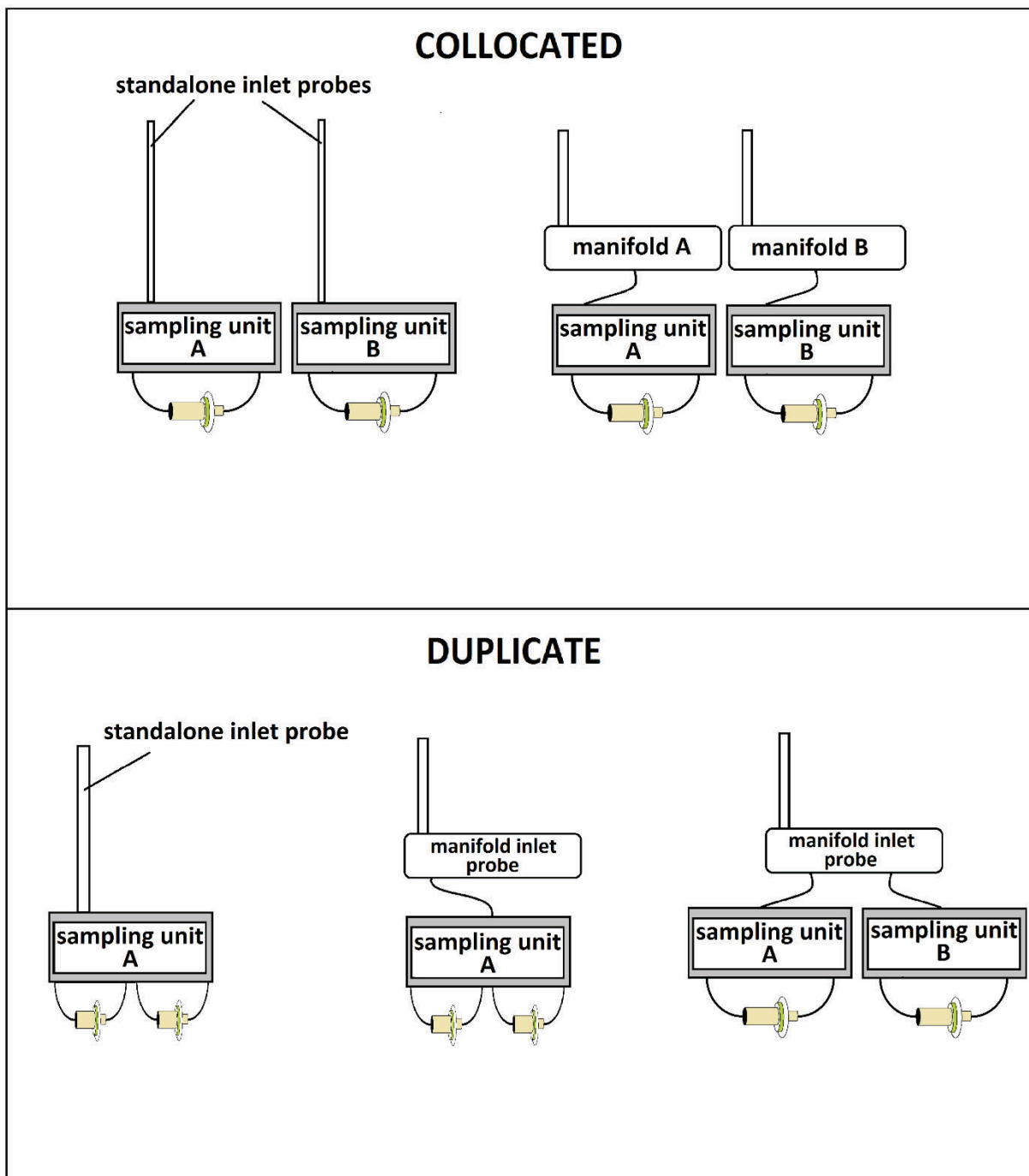

Figure 4.3-1. Collocated and Duplicate Carbonyls Sample Collection

More information on collocated samples is given in Section 4.3.8.2.3.

4.3.3.1.2 Duplicate Sample Collection. Duplicate sampling assumes that both the primary and duplicate sampling inlets are connected to the same inlet probe to the atmosphere whether connected to a manifold or a standalone inlet probe.

A duplicate sample may be collected, for example, by splitting (with a tee, or similar) the primary sample flow path onto two separate cartridges, where each cartridge has its own discrete and separate flow channel and/or flow control device (MFC, orifice, or rotameter) located within a single sampling unit.

More information on duplicate samples is given in Section 4.3.8.2.4.

4.3.3.2 Laboratory Precision. Laboratory precision for field-collected carbonyls cartridges is limited to replicate analysis of a single extract. Each DNPH cartridge is extracted as a discrete sample which does not permit assessing precision through the extraction process. Replicate analysis of a given extract is required with each analysis sequence and must show $\leq 10\%$ RPD for concentrations $\geq 0.5 \mu\text{g}/\text{cartridge}$.

Precision incorporating both the extraction and analysis procedures may be assessed by preparation, extraction, and analysis of duplicate LCSs. An LCS and LCS duplicate (LCSD) must be prepared minimally quarter, and are recommended with each extraction batch at a concentration in the lower third of the calibration range. The LCS/LCSD pair must show precision of $\leq 20\%$ RPD.

4.3.4 Managing Ozone. Ozone is present in the atmosphere at various concentrations ranging from approximately 20 ppb at rural sites to as much as 150 ppb at peak times in urban environments. Ozone is a strong oxidant and may impact the sampling and analysis in various ways. Ozone which is not removed from the sampled air stream may react directly with the DNPH reagent thereby making the DNPH unavailable for derivatizing carbonyl compounds. Ozone may also react with carbonyl-hydrazones on the sampled cartridge to degrade these compounds, leading to underestimation of carbonyl concentrations. These degradation byproducts may also be difficult or impossible to separate chromatographically from desired target compounds, resulting in overestimation or false positive detection of target compounds.

In order to mitigate the impact of ozone on carbonyl measurements, an ozone denuder/scrubber must be installed in the sampling unit flow path upstream of the DNPH cartridge(s). Typically, the removal of ozone by potassium iodide (KI) is effected by the oxidation of the iodide ion to iodine in the presence of water, as follows:

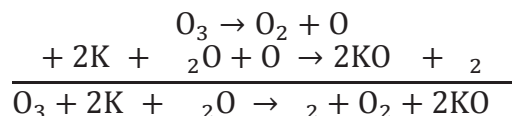

Several different KI ozone scrubbers are described in the following sections. For the NATTS program, ozone must be removed during the collection of carbonyls with the denuder in Section 4.3.4.1.

4.3.4.1 Copper Tubing Denuder/Scrubber. Method TO-11A describes an ozone denuder/scrubber and this is the preferred ozone removal method for the NATTS program. The scrubber is fashioned from coiled copper tubing whose interior has been coated with a saturated KI solution and which is heated to approximately 50°C or above to eliminate condensation.

Heating prevents the deposition of liquid water to the denuder walls which may both dissolve the KI coating and may clog the silica gel pores in the DNPH cartridge with KI as it recrystallizes. As this type of scrubber/denuder operates via titration, its efficacy over time is related to the amount of deposited KI, the total volume of sampled air, and the average ozone concentration of the sampled air. In general, it is presumed that this type of denuder/scrubber should be effective for up to 100,000 ppb-hours at flow rates of less than 1 L/minute.¹ A study not yet published at the time of this TAD's release has found that such copper tubing ozone scrubbers are effective for the 100,000 ppb-hours cited in TO-11A; they were able to efficiently remove 150 ppb O₃ over 30 consecutive days when operated at a flow rate of 1 L/min at relative humidities ranging from 10 to 85% at a nominal temperature of 25°C.² Given an average ozone concentration of approximately 70 ppb, this type of denuder/scrubber should effectively scrub ozone from the sampled air stream for all 61 annual 24-hour samples required by the NATTS Program without depleting the KI reagent. If the average concentration of ozone is greater than 70 ppb over the course of the year or the sampling frequency is increased from one-in-six days, or if duplicate sampling is performed more frequently than every other month such that the flow rate through the denuder is doubled during most sampling events (thereby exposing the scrubber to twice the burden of ozone), the life span of the KI denuder/scrubber will be proportionately reduced.

The denuder/scrubber must be replaced or recharged with KI minimally annually to ensure there is sufficient KI substrate to eliminate co-sampled ozone; they should also be recharged if ozone breakthrough is observed as decomposition products of O₃ attacking the DNPH and the formaldehyde hydrazone derivative (see reference 1 for more information). Denuders are commercially available or they may be recharged by recoating the copper tubing with a saturated solution of KI in deionized water (144 grams KI in 100 mL deionized water). The solution is maintained inside the copper tubing for minimally 15 minutes (some agencies suggest 24 hours or more), then the solution drained. The emptied tubing is then dried by a gentle stream of dry UHP nitrogen for minimally one hour.

When a sampling instrument is removed from service for recharging the KI denuder/scrubber and/or for calibration/maintenance, a best practice is to challenge the denuder with ozone at 120% of the maximum measured ozone concentration for several hours and measure the resultant downstream concentration. Such will demonstrate the ozone scrubber's efficacy prior to removal from the field. For denuders shown to be less than fully effective upon removal from the field, defined as downstream ozone concentration > 10 ppb or a breakthrough > 5%, chromatograms from recent sampling events should be examined for indications of ozone interference. Following recharge/replacement of the KI denuder/scrubber, the 120% ozone concentration challenge should be repeated to demonstrate effective ozone removal prior to its deployment for field use. The zero challenge of the sampling unit prescribed in Section 4.3.7.1.1 must be performed following recharging of the denuder/scrubber.

4.3.4.2 Sorbent Cartridge Scrubbers. Sorbent cartridges, such as silica gel, coated with KI are commercially available, but their use is not permitted due to their sorption of water vapor. Sampling in humid environments results in the sorbent bed becoming saturated with water, resulting in clogging of the cartridge substrate which substantially reduces or eliminates sample flow. While inexpensive and convenient for use, sorbent bed KI cartridges must not be employed for the NATTS Program sampling.

4.3.4.3 Other Ozone Scrubbers. Agencies may opt to develop custom-made KI ozone scrubber/denuders. The efficiency of ozone removal must be demonstrated for such custom systems. To demonstrate efficiency of ozone removal, the homemade scrubber/denuder must be challenged over a contiguous 24-hour period with a minimum of 100 ppb ozone at the flow rate for the carbonyl instrument sampler (typically approximately 1 L/min) and demonstrate breakthrough of < 5%. Agencies must also quantify the capacity of such scrubbers (for example, in ppb-hours) and with such data they must determine and codify in their quality system the minimum required recharge/replacement frequency of the scrubbers.

4.3.4.3.1 Cellulose Filter Ozone Scrubbers. The California Air Resources Board (CARB) removes ozone with cellulose filters coated with KI on the RM Environmental Systems Incorporated 924 and Xonteck 924 sampling units. These samplers are standalone and not installed in a separate shelter, so do not allow the ready installation of a heated copper tubing ozone scrubber. The DNPH cartridge is installed in close proximity (several millimeters) from the inlet probe, which is open to the atmosphere. The KI-coated filter is installed at the inlet probe, just upstream of the DNPH cartridge.

4.3.4.3.2 Modified DasibiTM Ozone Scrubber. In the DasibiTM scrubber fifteen 2-inch diameter copper mesh screens are arranged in a stacked formation. The magnesium oxide coated screens provided with the unit are exchanged for copper screens which are coated with KI. To coat the screens, they are immersed in a saturated KI solution in deionized water and air dried. The coated screens are assembled in the Dasibi enclosure with a fiberglass particulate filter at each end, the O-rings installed, and the enclosure secured with the supplied screws. This procedure imparts approximately 4 mmoles or 700 mg of KI over the fifteen 2-inch diameter screens. With this mass of KI, the scrubber should effectively remove ozone for approximately 300 sampling dates assuming 24 hours of sampling at 1 L/minute with ozone concentrations of 100 ppb.

In order to ensure that condensation does not impact the scrubber's performance, it should be maintained at a minimum temperature of 50°C.

4.3.5 Collection Media. EPA Compendium Method TO-11A specifies DNPH-coated silica gel sorbent cartridges for the collection of carbonyl compounds from ambient air. These DNPH cartridges may be prepared in house or purchased from commercial suppliers. Most NATTS sites utilize one of two commercial brands of media, specifically the Waters WAT037500 or Supelco S-10 cartridges. These cartridges are specified to meet the background criteria of TO-11A and typically exhibit proper flow characteristics. Examination of background concentrations and proficiency test data do not indicate an obvious difference in the performance between the two brands of cartridges. Laboratories may prepare DNPH cartridges in house; however, preparation is a time- and labor-intensive process which requires meticulous detail to cleanliness to ensure the resulting media are contaminant-free. The expense and resources involved in preparation of DNPH media in house is generally greater than the cost of purchasing commercially-available DNPH cartridge media. Regardless of the type of cartridge selected, the method performance specifications in Section 4.3.10 must be met.

4.3.5.1 Lot Evaluation and Acceptance Criteria. For each lot or batch of purchased or prepared DNPH cartridge, a representative number of cartridges must be analyzed to demonstrate that the lot or batch is sufficiently free of contamination. Most commercially-available DNPH cartridges are accompanied by a COA indicating the lot or batch background of various carbonyls. While a COA provides a level of confidence that the lot or batch is sufficiently clean, laboratories must verify the background levels of carbonyls in each batch or lot of cartridges.

For commercially-purchased cartridges, a minimum of three cartridges, or 1% of the total lot, whichever is greater from each lot or batch, must be extracted and analyzed. For cartridges prepared in house, a minimum of three cartridges per each preparation batch must be extracted and analyzed. Each cartridge tested in the lot or batch must meet the criteria listed in Table 4.3-2. Ongoing analysis of method blanks permits continual assessment of the lot's contamination levels.

Additionally, agencies may elect to perform flow evaluations of the lot(s) to ensure cartridges do not overly restrict sampling flows.

Table 4.3-2. Maximum Background per Lot of DNPH Cartridge

Carbonyl Compound	Not-to-Exceed Limit (µg/cartridge)
Acetaldehyde	< 0.10
Formaldehyde	< 0.15
Acetone ^a	< 0.30
Other Individual Target Carbonyl Compounds	< 0.10

^a Acetone is not a target compound and should not be grounds for lot disqualification unless it interferes with other target analytes in the chromatogram.

If any cartridge tested exceeds these criteria, an additional three cartridges, or 1% of the total lot, whichever is greater, must be tested to evaluate the lot. If the additional cartridges meet the criteria, the lot or batch is acceptable for sampling. If any of the additional cartridges fail criteria, the lot or batch must not be used for NATTS sampling and should be returned to the provider.

4.3.5.2 Cartridge Handling and Storage. DNPH sampling cartridge media are typically shipped unrefrigerated by the supplier. DNPH cartridges must be stored refrigerated at ≤ 4°C upon receipt. Unsampled cartridges must be maintained sealed in their original packaging and protected from light (foil pouch or similar opaque container) until installed for sample collection or prepared as QC samples as light may degrade the DNPH derivatives. Cartridges which are not stored appropriately may suffer from degradation of the DNPH reagent and may show increased levels of contaminants from passive sampling of target compounds and interferants.

DNPH cartridges should only be handled by staff wearing powder-free nitrile or vinyl gloves or equivalent. Measures must be taken to avoid exposure of DNPH cartridges (unsampled or collected samples) to exhaust fumes, sunlight, elevated temperatures, and laboratory environments where carbonyl compounds such as acetone may contaminate sampling media.

As soon as possible after sample collection, cartridges must be capped (if caps are provided), sealed in the foil pouch (to protect from light and the ambient atmosphere), and transported (shipped) and stored refrigerated at $\leq 4^{\circ}\text{C}$. Cartridges must be transported in coolers with ice, freezer packs, or equivalent method for providing refrigeration during transport to and from the laboratory. Monitoring the shipping temperature with a calibrated min-max type thermometer is a best practice.

4.3.5.3 Damaged Cartridges. DNPH cartridges are susceptible to water damage and to physical damage. Unused or sampled cartridges, including blanks, must not indicate clumping of the silica gel sorbent which is indicative of water condensation inside the cartridge sorbent bed. Physical damage to cartridges such as cracks, broken inlet or outlet fittings, or openings into the sorbent bed are pathways for the ingress of contamination. Cartridges which indicate such damage must not be used in the NATTS Program, or if already used for sample collection, must be voided and a make-up sample should be collected per Section 2.1.2.1, where possible.

4.3.5.4 Cartridge Shelf Life. DNPH cartridges that are commercially purchased typically are provided with an expiration from the manufacturer specifying storage conditions. Agencies must comply with the manufacturer expiration, if given. Degradation of the DNPH reagent or silica gel sorbent bed which may reduce collection efficiency to unacceptable levels may occur after the assigned expiration date. Additionally, as DNPH cartridge media age, their levels of background contamination are likely to have increased, perhaps to unacceptable levels, due to passive sampling and uptake from the ambient atmosphere. For cartridges which are not assigned an expiration date or are assigned an arbitrary expiration date (i.e. six months from time of receipt) by the manufacturer, agencies should work within this expiration period as practical. For such cartridges which have exceeded the arbitrary expiration period, they may be shown to be acceptable if levels of contaminants meet the criteria in Table 4.3-2 and there remains sufficient DNPH to conduct sampling and ensure excess DNPH levels remain following sample collection. This level of DNPH on unsampled cartridges is recommended to be a reduction of DNPH area counts of no more than $\sim 15\%$ from the original lot acceptance analysis.

4.3.6 Method Detection Limits. MDLs for carbonyls must be determined minimally annually by following the procedures in Section 4.1. To ensure that the variability of the media and the extraction process is characterized in the MDL procedure, separate cartridges must be spiked and extracted (it does not suffice to simply analyze a low-concentration solution of derivatized carbonyls). For example, laboratories determining the MDL following Section 4.1.2.1 must prepare a minimum of seven method blank cartridges and a minimum of seven spiked cartridges over the course of three different batches (different calendar dates – preferably non-consecutive). These samples must be analyzed in three separate analytical batches (different calendar dates – preferably non-consecutive). The MDL is then determined by calculating the MDL_{sp} and MDL_{b} and selecting the higher of the two concentrations as the laboratory MDL. Please refer to section 4.1.2 for specific details on selecting a spiking concentration, procedures, and calculations for determining MDLs.

All steps performed in the preparation and analysis of field sample cartridges (such as dilution of extracts) must be included in the MDL procedure. Cartridges should be spiked and the solvent permitted to dry prior to extraction.

Determined MDLs for Tier I core analytes must meet (be equal to or lower than) those listed in the most recent workplan.

4.3.7 Carbonyls Sample Collection Equipment, Certification, and Maintenance.

Carbonyls are collected by drawing the ambient atmosphere through a DNPH cartridge at a known flow rate of approximately 0.25 to 1.25 L/minute over the 24-hour collection period. An ongoing EPA funded study not yet published at the time of this TAD's release indicated that at 1.25 L/minute there was no breakthrough at aldehyde concentrations of 5 ppbv. Collection of samples with flow rates of approximately 1 L/minute represents an appropriate compromise between maximizing collection efficiency and sensitivity.

4.3.7.1 Sampling Equipment. The sampling unit may control flow rate by a MFC or by a combination critical orifice and flow rotameter. Advantages of MFCs include that they provide real-time control of a specified flow, adjusting for changes in backpressure and sampling conditions. Additionally, MFC flow data may be continuously captured and recorded so as to permit calculation of a total sampled volume. Such is in contrast with sampling units with rotameters for which only beginning and ending flow rate measurements are available for total volume calculations. Another limitation of rotameters is that their indicated flows must be manually corrected to standard conditions using the barometric pressure and temperature at the site on the day of sample collection. Rotameters are less complicated and expensive than MFCs.

A variety of commercial and custom-built sampling instruments is available. These range from simple flow pumps controlled via critical orifice and flow rotameter to multi-channel/multi-pump systems connected through multiple MFCs and operated by touch screen control. Some units are also able to simultaneously collect VOC canisters or allow remote computer login to monitor sampling events and download sample collection data. Note that such options are advantageous, but not required.

Regardless of the additional features, each sampling unit must minimally include the following options:

- Elapsed time indicator
- Multi-day event control device (timer)
- MFC (preferred) or critical orifice and flow rotameter to control sampling flow
- Ozone denuder

Each sampling unit must be flow calibrated annually and shown to be free of positive bias.

4.3.7.1.1 Sampling Unit Zero Check (Positive Bias Check). It is required that prior to field deployment and minimally annually thereafter each carbonyl sampling unit be certified to be free of positive bias by collection over 24 hours of a sample of humidified HCF zero air (or equivalent carbonyl- and oxidant-free air) or UHP nitrogen. Each channel of each carbonyl sampling instrument should be so verified. A best practice is to perform this procedure TTP where the entire in-situ sampling train is tested. As many agencies do not possess the resources to perform TTP procedures, the zero check may be performed in the laboratory where as much of the flow path as possible must be included. Minimally the portion of the flow path comprising

the ozone denuder/scrubber and sampling unit into which the DNPH cartridge is installed should be verified as non-biasing. The positive bias check should be performed following the recharge or replacement of the ozone scrubber/denuder, is ideally performed following the annual recalibration of the flow control device, and ideally includes the length of tubing that connects the instrument to the manifold or the entire new or cleaned inlet probe.

A recommended zero check procedure is described below. For agencies which cannot perform the annual maintenance (ozone scrubber/denuder recharge, flow control calibration) and challenge in house, manufacturers, the national contract laboratory, or third party laboratories may perform this service. Regardless of the exact procedure adopted, when performed, the performance specifications listed below must be met.

The zero check is performed by simultaneously providing humidified (50 to 70% RH) hydrocarbon- and oxidant-free zero air or UHP nitrogen to the sampling unit for collection onto a cartridge and to a separate reference cartridge connected directly to the supplied zero gas source. As closely as possible, sample collection parameters for the ozone scrubber/denuder, flow rate, etc., should mimic those for field sample collections.

The humidified zero gas flow is provided to a challenge manifold constructed of chromatographic stainless steel. The manifold should include three additional ports for connections to the sampling unit inlet, reference sample, and a rotameter to serve as a vent to ensure that the manifold remains at ambient pressure during sample collection. The reference sampling flow is set to approximate the flow rate of the sampling unit with an MFC, mechanical flow device, or needle valve downstream from the reference cartridge. Zero gas is supplied such that there is excess flow to the manifold as indicated by the rotameter on the vent port. Sampling is performed over 24 hours to simulate real world conditions, into the reference cartridge and through the sampling unit and into the zero challenge cartridge.

Another method to provide the sampling unit with carbonyl-free gas is to install a DNPH sampling cartridge on the inlet to sampling unit. This cartridge traps the carbonyl compounds and replaces the zero gas source. A zero challenge cartridge collected in this manner should be compared to a field blank as the reference cartridge.

Analysis for target compounds in the zero challenge cartridge must show that each compound is ≤ 0.2 ppbv greater than the reference cartridge. Comparison to the reference cartridge permits evaluating the contribution of the sampling unit irrespective of cartridge background contamination. Where exceedances are noted for the zero challenge cartridge, corrective action must be taken to remove the contamination attributable to the sampling unit and the sampling unit zero challenge repeated to ensure criteria are met before sampling may be conducted.

4.3.7.1.2 Carbonyls Sampling Unit Flow Calibration. Initially prior to field deployment and whenever independent flow verification indicates the flow tolerance has been exceeded, the flow control device (MFC or flow rotameter) must be calibrated against a calibrated flow transfer standard and the flow control device (or regression for a flow rotameter) adjusted to match the transfer standard (or the regression characterizing its response must be reset to match the transfer standard).

Note that manufacturer procedures for calibration may be followed if flows can be calibrated at standard conditions. A suitable calibration procedure for MFCs is as follows. The sampling unit pump(s) and MFC should be warmed up and run for approximately five minutes to ensure the MFC is stable. A blank DNPH cartridge should be installed into the air sampler to provide a pressure drop to the pump, and airflow through the cartridge commenced. The calibrated flow transfer standard should be connected at the upstream end of the sampling unit so as much of the flow path is included as possible in order to identify potential leaks in the flow path that may not otherwise be evident. MFC calibration should be performed at minimally three flow rates: the typical flow rate for sample collection, approximately 30% less than the typical flow of sample collection, and approximately 30% higher than the typical flow of sample collection. Particular attention should be paid to ensure that the correct calibration conditions are compared – that both the reading on the flow transfer standard and MFC are in standard (25°C and 760 mm Hg) conditions.

Calibration of flow rotameters is more complex than calibration of MFCs. The temperature and barometric pressure both at the time of calibration and during sample collection are needed to correct the indicated rotameter flow rate to the actual flow rate.³ A suitable rotameter calibration procedure is given below.

The flow rotameter should be challenged with a flow of air which is simultaneously measured by a calibrated flow transfer standard. At each flow rate set point, the flow reading from the flow transfer standard and the corresponding reading from the flow rotameter are recorded. The challenged flow range should include a minimum of five flow rates that span the useful scale of the flow rotameter and include the expected indicated flow rate during field operation. A linear regression is then generated by plotting the flow transfer (known) readings on the x-axis and the flow rotameter readings (unknown) on the y-axis. The resulting linear regression equation allows the rotameter's indicated flow (on the y-axis) to be related to the known calibrated flow of the rotameter on the x-axis at the specific conditions of ambient temperature and barometric pressure at which the flow calibration is performed.

To calculate the actual flow rate during operation of the rotameter in the field, the rotameter flow rate during calibration is found by way of cross reference with the indicated flow from the rotameter calibration plot. Stated another way, the rotameter is read, and this indicated flow is found on the y-axis of the calibration plot and the corresponding flow rate during calibration is read from the x-axis (or the regression equation is solved for x). This flow rate during calibration, Q_c , along with the ambient temperature and pressure during calibration and during sample collection are input into the following equation to calculate the flow during sample collection:

$$Q_a = Q_c \sqrt{\frac{P_c T_a}{P_a T_c}}$$

where:

Q_a = volumetric flow rate at ambient (or local) conditions where the rotameter is operated

Q_c = volumetric flow rate at ambient (or local) conditions during rotameter calibration

P_c = barometric pressure during rotameter calibration

P_a = barometric pressure at ambient (or local) conditions where the rotameter is operated
 T_a = absolute temperature at ambient (or local) conditions where the rotameter is operated
 T_c = absolute temperature during rotameter calibration

For flow rotameters which are calibrated by delivery of a known flow measured at standard conditions, the calculation of the ambient flow at standard conditions is performed according to the following equation:

$$Q_{a,std} = Q_{c,std} \sqrt{\frac{P_a T_c}{P_c T_a}}$$

where:

$Q_{a,std}$ = flow rate where the rotameter is operated, in standard conditions (760 mm Hg, 25°C)

$Q_{c,std}$ = flow rate where the rotameter was calibrated, in standard conditions
 T_c , P_c , T_a , and P_a are as above.

As an example, assume that a rotameter is calibrated – its indicated flow is cross-referenced to a calibrated flow – by delivery of known flows measured at standard conditions. Assume as well that the calibration is performed near sea level at a typical laboratory temperature such that $P_c = 760$ mm Hg and $T_c = 20^\circ \text{C} = 293.15 \text{ K}$, and that a field sample is collected in the summer in Grand Junction, Colorado, such that $P_a = 650$ mm Hg, $T_a = 35^\circ \text{C} = 308.15 \text{ K}$. Assume the indicated rotameter flow is 800 mL/min, which from the calibration plot corresponds to a known flow rate at standard conditions of 750 mL/min. The actual flow rate, in standard conditions, for this carbonyl sample in Grand Junction is equal to $750 \text{ mL/min} \cdot \sqrt{(650/760 \cdot 293.15/308.15)} = 681 \text{ mL/min}$.

To perform a flow calibration verification on the sampling unit flow, the sampling unit pump(s) should be warmed up and run for approximately five minutes to ensure flows are stable. A blank DNPH cartridge should be installed into the air sampler to provide a pressure drop to the pump, and airflow through the cartridge commenced. The calibrated flow transfer standard should be connected at the upstream end of the sampling unit so as much of the flow path is included as possible in order to identify potential leaks in the flow path that may not otherwise be evident. The sample flow is then set to the flow setting of typical sample collection and the flow compared to the transfer standard. Ensure that both the sampling unit and flow transfer standard are set to report flows at standard conditions of 25°C and 760 mm Hg. Rotameter flows must be converted to standard conditions ($Q_{a, std}$) with the temperature and barometric pressure measured at the time of the calibration check via the equation above. The sampling unit flow in standard conditions must be within 10% of the flow indicated by the transfer standard. If outside of this range, the MFC must be recalibrated or the regression equation for the flow rotameter must be re-established.

4.3.7.1.3 Moisture Management. Humidity plays several roles with regard to sample collection. Water vapor can condense on interior portions of the sample flow path

potentially resulting in a low measurement bias due to carbonyls dissolving in the liquid water. To minimize the condensation of liquid water onto the interior surfaces of the flow path, the ozone scrubber is maintained at a minimum of 50°C. Additionally, connecting tubing may be insulated to maintain the elevated temperature and discourage condensation. High humidity in sampled atmospheres may also lead to somewhat lower carbonyl collection efficiencies due to the possible back reaction of the DNPH-carbonyl derivative with water to form the free carbonyl. The reverse reaction is less likely for aldehydes due to their higher reactivity, however can lead to lower collection efficiencies for ketones.⁴

4.3.7.2 Sampling Train Configuration and Presample Purge. The carbonyl sampling inlet probe may be standalone or connected to a manifold inlet. For either configuration, components comprising the wetted surfaces of the flow path must be constructed of borosilicate glass, PTFE Teflon, or chromatographic grade stainless steel. Due to the reactivity of materials such as copper or adsorptive/desorptive properties of materials such as FEP Teflon[®], rubber, or plastic tubing, these materials must not be utilized within the flow path.

For sites having a common inlet manifold, it must be constructed of borosilicate glass. A bypass pump is connected to the manifold to continuously pull ambient air through the manifold. The flow rate of the bypass pump must be minimally double the total maximum sampling load for all sampling units connected to the manifold. Where the carbonyls sampling unit has its own inlet probe separate from the manifold, no additional bypass pump is necessary.

Regardless of how the ambient air is introduced into the sampling instrument, it is *strongly recommended* that the inlet line to the sampling unit be purged with ambient air such that the equivalent of a minimum of 10 air changes is completed just prior to commencing sample collection. This purge eliminates stagnant air and flushes the inlet line.

4.3.7.3 Carbonyl Sampling Inlet Maintenance. Over time, the carbonyl inlet probe and connecting tubing will become laden with particulate residue. This particulate residue may scrub target analytes from the gas stream and may act as sites for adsorption/desorption. Wetted surfaces of inlet probes and connecting tubing must be cleaned and/or replaced minimally annually, and preferably every six months, particularly if operated in an urban environment where there is a higher concentration of PM.

Only deionized water should be used to clean inlet lines. If the lines are short enough, a small brush can be employed in concert with the deionized water to effectively clean the interior of the tubing. It may be more effective to simply replace the tubing on a prescribed basis. Many carbonyl sampling units utilize Teflon[®] particulate filters upstream of the denuder to alleviate particulate loading of internal parts (valves and MFCs) of sampling units. Such particulate filters must be replaced periodically, recommended to be replaced after six months but must not exceed annually.

4.3.8 Sample Collection Procedures and Field Quality Control Samples

4.3.8.1 Sample Collection Procedures. Prior to beginning sample collection, all DNPH cartridge lot characterization must be completed as described in Section 4.3.5.1. The sampling

unit must have passed the zero check in the previous 12 months, the sampling inlet line cleaned or replaced in the previous 12 months, the flow control device calibrated within the past 12 months, and, if so equipped, the particulate filter must have been changed in the previous year.

In addition to the procedures described below, all cartridges must be handled as prescribed in Section 4.3.5.2.

4.3.8.1.1 Sample Setup. Blank DNPH cartridge media are transported to the site in a cooler on ice packs where they are either stored on site in a refrigerator or freezer (with calibrated temperature monitoring), or installed into the sampling unit for sample collection.

Appropriate blank, non-exposed DNPH cartridge(s) are installed into the sampling unit and the sample collection program verified to comply with Section 4.3.8.1.3. The flow rate of collection should be set to a known calibrated flow rate of approximately 0.7 to 1.5 L/minute (at standard conditions) for a total collection volume of 1.0 to 2.2 m³ at standard conditions. Method sensitivity is linearly proportional to the total collection volume, and the latter should be adjusted within the specified range so that MDL MQOs are attained. An ongoing EPA funded study not yet published at the time of this TAD's release indicated that at these flow rates there was no breakthrough at aldehyde concentrations of 5 ppbv. Flow rates greater than 1.5 L/minute may result in decreased in collection efficiency.

For sampling units which permit a leak check function on the sample pathway, a leak check must be initiated prior to sample collection. A successful leak check indicates no flow through the sampling unit.

The initial flow rate, date and time of sample initiation, and cartridge identification information must be recorded on the sample collection form.

4.3.8.1.2 Sample Retrieval. The collected cartridges must be retrieved as soon as possible after the conclusion of sampling in order to minimize degradation of the carbonyl-DNPH derivatives, preferably within 72 hours of the end of sample collection. The ending flow rate, total flow (if given), and sample duration must be documented on the sample collection form. The cartridges are removed from the sampling unit, the caps installed on the inlet and outlet of each cartridge, each cartridge sealed in its separate foil pouch, and the pouches immediately placed in cold storage. The sample must be kept cold during shipment such that the temperature remains $\leq 4^{\circ}\text{C}$, and the temperature of the shipment must be determined upon receipt at the laboratory. A best practice to minimize contamination is to transport the sealed foil pouch in an outer zipperlock bag containing activated carbon.

Sampling units which incorporate computer control of the sampling event with associated data logging may provide the above information which must be printed and attached to the sample collection form or transcribed. For such sampling units, the data logged should be reviewed to ensure the sample was collected appropriately and there are no flags or other collection problems that may invalidate the collected sample. Collected data should be downloaded and provided to the analytical laboratory. The sample custody form must be completed and accompany the

collected sample at all times until relinquished to the laboratory. COC documentation must comply with Section 3.3.1.3.7.

4.3.8.1.3 Sampling Schedule and Duration. Carbonyl sample collection must be performed on a one-in-six days schedule per the national sampling calendar for 24 ± 1 hours beginning at midnight and concluding on midnight of the following day, local time unadjusted for daylight savings time. For missed or invalidated samples, a make-up sample should be scheduled and collected per Section 2.1.2.1. Clock timers controlling sampling unit operation must be adjusted so that digital timers are within ± 5 minutes of the reference time (cellular phone, GPS, or similar accurate clock) and mechanical timers within ± 15 minutes.

4.3.8.2 Field Quality Control Samples. QC samples co-collected with field samples include field and trip blanks, collocated and duplicate samples, field matrix spikes, and breakthrough samples. Blank cartridges provide information on the potential for field-collected samples to be subjected to positive bias, whereas spiked cartridges assess the potential for the presence of both positive and negative bias.

4.3.8.2.1 Field Blanks. Field blanks must be minimally collected once per month; however, it is a best practice to increase this frequency, ideally to collect a field blank with each collection event. Field blanks must be handled in the same manner as all other field-collected samples, transported in the same cooler and stored in the same refrigerator/freezer storage units. Field blanks are exposed to the ambient atmosphere for approximately five to ten minutes by installation of the blank cartridge into the sampling position on the primary sampling unit with no air drawn through the cartridge. The field blank cartridge is then removed from the sampling unit and placed immediately into cold storage. Collection of the field blank in this manner characterizes the handling of the blank cartridge in the sampling position in the primary sampling unit and standardizes field blank collection across the NATTS network for carbonyls and with metals and PAHs field blank collection.

An exposure blank is similar to a field blank, but is not required, and may be collected via several protocols. The exposure blank includes opening the cartridge pouch, removing the caps exposing the cartridge to the ambient atmosphere briefly, and exposing it to the temperature conditions of the primary sampling cartridge for the same duration as the co-collected field samples. Like a field blank, air is not drawn through the exposure blank cartridge. Some sampling units have a dedicated “field blank” channel for installation of the exposure blank through which air is not permitted to flow. For multi-channel sampling units, the exposure blank may be installed in channel which is not activated for sample flow. For sampling units which have neither a dedicated blank channel nor unused channel available on the sampling unit, the exposure blank cartridge may be removed from the foil pouch, installed in the sampling unit for five to ten minutes, the cartridge uninstalled and the end caps reinstalled, and the cartridge placed near the sampling unit for the duration the primary sample is installed in the sampling unit.

Field blanks and exposure blanks may passively sample ambient air throughout the time of exposure, and as a result may have somewhat higher background levels as compared to lot

blanks, trip blanks, or laboratory method blanks. Field blanks must meet and exposure blanks should meet the following criteria listed in Table 4.3-3.

Table 4.3-3. Carbonyls Field Blank Acceptance Criteria

Carbonyl Compound	Not-to-Exceed Limit (µg/cartridge)
Acetaldehyde	< 0.40
Formaldehyde	< 0.30
Acetone ^a	< 0.75
Sum of Other Target Carbonyls	< 7.0

^a Acetone is not a target compound and should not be grounds for field blank criteria failure unless it interferes with other target analytes in the chromatogram.

Failure to meet the field blank criteria indicates a source of contamination and corrective action must be taken as soon as possible. For agencies which collect associated trip blanks, comparison of the field blank to trip blank values may provide meaningful insight regarding the contamination source. Field-collected samples associated with field blanks which do not meet these criteria must be flagged/qualified when input to AQS. For field blanks which fail criteria and are collected with each sampling event, the co-collected field sample results must be flagged/qualified when input to AQS. For failing field blanks which are collected on a less frequent basis (i.e. monthly basis), field collected samples since the last acceptable field blank must be flagged/qualified when input to AQS.

Field samples must not be corrected for field blank values. Field blank values must be reported to AQS so that data users may estimate field and/or background contamination.

4.3.8.2.2 Trip Blanks. Trip blanks are a useful tool to diagnose potential contamination in the sample collection and transport of carbonyl samples. Trip blanks are not required, but are a best practice. A trip blank consists of a blank unopened cartridge which accompanies field sample cartridges at all times to and from the laboratory. The trip blank cartridge is stored in the same refrigerator/freezer, transported in the same cooler to and from the site, and kept at ambient conditions during sample collection. The cartridge must remain sealed in the foil pouch and not removed from its pouch until extracted in the laboratory.

Background levels on the trip blank should be comparable to the lot blank average determined as in Section 4.3.5.1 and must not exceed the values listed in Table 4.3-2. Exceedance of these thresholds must prompt corrective action and the results of the associated field-collected samples must be appropriately qualified when input to AQS.

4.3.8.2.3 Collocated Samples. Collocated sampling is described in detail in Section 4.3.3.1.1. Where such is performed, it must be done at a frequency of no less than 10%, meaning approximately one collocated sample every other month.

Following extraction and analysis the collocated cartridge results are compared to evaluate precision. Precision must be $\leq 20\%$ RPD for results ≥ 0.5 µg/cartridge. Root cause analysis must be performed for instances in which collocated samples fail this precision specification and the results for both the primary and collocated samples must be qualified when entered into AQS.

4.3.8.2.4 Duplicate Samples. Duplicate sampling is described in detail in Sections 4.3.3.1.1 and 4.3.3.1.2. Where such is performed, it must be done at a frequency of no less than 10%, meaning approximately one duplicate sample every other month.

Following extraction and analysis the duplicate cartridge results are compared to evaluate precision. Precision must be $\leq 20\%$ RPD for results $\geq 0.5 \mu\text{g}/\text{cartridge}$. Root cause analysis must be performed for instances in which duplicate samples fail this precision specification and the primary and duplicate results must be qualified when entered into AQS.

4.3.8.2.5 Field Matrix Spikes. Performance of field matrix spiked sample collection is a best practice, but is not required. Field matrix spikes are prepared by spiking a blank DNPH cartridge with a known amount of analyte (either derivatized or underivatized) prior to dispatching to the field for collection. The field matrix spike is handled identically to field samples; sample storage, transport, and extraction are identical. Field matrix spiked samples are collected concurrently with a non-spiked primary sample as a duplicate sample per Section 4.3.8.2.3 via duplicate channel or split sample flow.

The primary field sample and matrix spiked sample analysis results are evaluated for spike recovery based on the amount spiked prior to shipment to the field as follows:

$$\% \text{Recovery} = \frac{(\text{Field Matrix Spike Result} - \text{Primary Sample Result})}{\text{Nominal Spiked Amount}} \cdot 100$$

Spike recovery should be within $\pm 20\%$ (80 to 120% recovery) of the nominal spiked amount. In the event of an exceedance, root cause analysis should be performed to determine sources of negative or positive bias, as needed, for example, sources of contamination or reasons for the loss of analyte. High recoveries may indicate contamination in the matrix spike sample collection channel or loss in the primary sample collection channel. Low recoveries may indicate a poorly functioning ozone denuder, which permits ozone to pass through the sample collection flow path and degrade the spiked analytes.

4.3.8.2.6 Breakthrough Samples. While not required, collection of breakthrough samples is a best practice. A breakthrough sample is a second DNPH cartridge connected immediately downstream of the primary sample cartridge. Periodic collection of breakthrough samples provides a level of assurance that the primary sample cartridge is efficiently trapping target carbonyls. For sites conducting breakthrough sampling the recommended frequency is once per month which should be described in the agency NATTS QAPP, SOP, or similar controlled document.

Note that this breakthrough cartridge will increase the pressure drop in the sampling system and may require an adjustment in the operation of the sampling unit to achieve the desired flow rate.

Breakthrough sample results must meet the field blank criteria listed in Table 4.3-3.

4.3.9 Carbonyls Extraction and Analysis. Target carbonyls collected on the DNPH cartridges are extracted and analyzed per EPA Compendium Method TO-11A¹ according to the following guidance.

4.3.9.1 Analytical Interferences and Contamination

4.3.9.1.1 Analytical Interferences. The carbonyl-hydrazone derivatives are separated with a HPLC system and are typically detected at 360 nm with a photodiode array or similar detector operating at UV wavelengths. Identification is based on retention time matching with known standards. MS and photodiode array (PDA) detectors are also an option if more definitive identification and quantification are desired or required. Minimally, analysis by HPLC-UV must be performed.

Interferences from co-eluting peaks may result from hydrazones formed by co-collected compounds or reactions with co-collected compounds which form artifacts. Such co-eluting peaks may form as dimers or trimers of acrolein or be the result of chemical reactions with nitrogen oxides. Target analyte peaks which indicate shoulders, tailing, or inflection points should be investigated to ensure these chromatographic problems are not related to a co-eluting interference.

4.3.9.1.2 Labware Cleaning. Labware must be thoroughly cleaned prior to use to eliminate potential interferences and contamination. Regardless of the specific procedures implemented, all method performance specifications for cleanliness must be met. Volumetric labware used for collection of cartridge eluent can show buildup of silica gel residue over time, requiring aggressive physical cleaning methods with laboratory detergent and hot water. Clean all associated labware by rinsing with ACN, washing with laboratory detergent, rinsing with deionized water, rinsing with ACN or methanol, and air drying or drying in an oven at no more than 80 to 90°C.⁵ Heated drying of volumetric ware at temperatures > 90°C voids the manufacturer volumetric certification.

4.3.9.1.3 Minimizing Sources of Contamination. Several target analytes in this method are typically present in ambient air and may contaminate solvents and the DNPH reagent if appropriate preventive measures are not in place. ACN used for sample extraction, standards preparation, and mobile phase preparation must be carbonyl-free HPLC grade or better (as indicated by the supplier or on the COA) and must be stored tightly capped away from sources of carbonyls. DNPH cartridges must be handled properly per Section 4.3.5.2.

Laboratories which process environmental samples for organic compounds such as pesticides typically employ extraction with acetone or other solvents which may contaminate DNPH cartridge media and carbonyl extraction solvents. Laboratory areas in which cartridges are stored, extracted, and analyzed should be free of contaminating solvent fumes. Carbonyls handling areas should have heating, ventilation, and air conditioning systems separate from such laboratory operations.

4.3.9.2 Reagents and Standard Materials

4.3.9.2.1 Solvents. Solvents employed for extraction, preparation of standards solutions, and preparation of mobile phase must be high-purity carbonyl-free, HPLC grade, and shown by analysis to be free of contaminants and interferences. Such solvents include ACN, methanol, and deionized water. Deionized water must be ASTM Type I (18 M Ω ·cm).

4.3.9.2.2 Calibration Stock Materials. Calibration source material must be of known high purity and must be accompanied by a COA. Calibration materials should be neat high purity solids or sourced as certified single component or component mixtures of target compounds in an appropriate solvent (i.e., ACN or methanol).

Neat solid material must be weighed with a calibrated analytical balance with the appropriate sensitivity for a minimum of three significant figures in the determined standard mass. The calibration of the balance must be verified on the day of use with certified weights bracketing the masses to be weighed. Calibration standards diluted from stock standards must be prepared by delivering stock volumes with mechanical pipettes or calibrated gastight syringes and the volumes dispensed into Class A volumetric labware to which ACN is added to establish a known final dilution volume.

4.3.9.2.3 Secondary Source Calibration Verification Stock Materials. A secondary source standard must be prepared to verify the calibration of the HPLC on an ongoing basis, minimally immediately following each ICAL. The secondary source stock standard must be purchased from a different supplier than the calibration stock material or, only if unavailable from a different supplier, may be of a different lot from the same supplier as the calibration material.

4.3.9.2.4 Holding Time and Storage Requirements. Unopened stock materials are appropriate for use until their expiration date provided they are stored per manufacturer requirements. Once opened, stock materials may not be used past the manufacturer recommended period or, if no time period is specified, not beyond six months from the opened date. To use the standard materials past this time period, standards must have been demonstrated to not be degraded or concentrated by comparison to freshly opened standards. Unopened stock materials must be stored per manufacturer recommendations. All stock and diluted working calibration standards must be stored at $\leq 4^{\circ}\text{C}$ in a separate refrigeration unit from sample cartridges and sample extracts.

4.3.9.3 Cartridge Holding Time and Storage Requirements. All field-collected cartridges must be stored at $\leq 4^{\circ}\text{C}$ and extracted within 14 days of the end of collection. These conditions similarly apply to laboratory-prepared QC samples, which must be stored at $\leq 4^{\circ}\text{C}$ and extracted within 14 days of preparation. Extracts must be analyzed within 30 days of extraction. Results input to AQS must be appropriately qualified for failure to meet the holding time and/or storage criteria.

4.3.9.4 Cartridge Extraction

4.3.9.4.1 Laboratory Quality Control Samples. With each extraction batch of 20 or fewer field-collected cartridges, which may include the various field QC samples such as those listed in Section 4.3.8.2, the following negative and positive laboratory QC samples must be prepared (except LCS/LCSD which must be prepared/analyzed minimally quarterly – recommended with each batch). For batch sizes of more than 20 field-collected cartridges, n such QC samples of each type must be added to the batch, where $n = \text{batch size} / 20$, and where n is rounded to the next highest integer. Thus for batch sizes of 30, two of each of the following QC samples would be included in each batch. A best practice would be to process field-collected cartridges in batches of no more than 20 at a time.

- Extraction Solvent Method Blank (ESMB): An ESMB is prepared by transferring the extraction solvent into a flask just as an extracted sample. The purpose of this negative control is to demonstrate that the extraction solvent is free of interferences and contamination and that the labware washing procedure is effective. Analysis must show target compound responses are less than the laboratory MDL_{sp} for MDLs determined via Section 4.1.3.1 or the $s \cdot K$ portion of the MDL for MDLs determined via Section 4.1.3.2.
- Method Blank (MB): The MB is a negative control that may also be referred to as the cartridge blank. The MB is a blank unopened cartridge (that has not left the laboratory) which is extracted identically to field samples. All target analytes must meet criteria specified in Table 4.3-2.
- Laboratory Control Sample (LCS): The LCS, also referred to as the laboratory fortified blank (LFB), is a positive control prepared by spiking a known amount of underivatized or derivatized DNPH-carbonyl target analyte onto a cartridge such that the expected extract concentration is in the lower third of the ICAL range. The spiked cartridge is allowed to sit for minimally 30 minutes to allow the solvent to dry following addition of the DNPH-carbonyl in solution. The LCS is then extracted with the same extraction solvent and method employed for field samples to assess bias in matrix of the extraction and analysis procedures. Recovery of the LCS must be within 80 to 120% of nominal for formaldehyde and 70 to 130% of nominal for all other target carbonyls.
- Laboratory Control Sample Duplicate (LCSD): The LCSD is prepared and extracted identically to the LCS. The LCSD assesses precision through extraction and analysis. Recovery of the LCSD must be within 80 to 120% of nominal for formaldehyde and 70 to 130% for all other target carbonyls. The LCS and LCSD results must show RPD of $\leq 20\%$.

All field-collected and laboratory QC samples in a given extraction batch must be analyzed in the same analysis batch (an analysis batch is defined as all samples analyzed together within a 24-hour period).

Laboratories must take corrective action to determine the root cause of laboratory QC exceedances. Field-collected sample results associated with failing QC results (in the same

preparation batch or analysis batch) must be appropriately qualified when input into AQS. In order to simplify troubleshooting when experiencing QC failures, QC sample cartridge media and extraction solvent lots should be the same, where possible.

4.3.9.4.2 Cartridge Extraction Procedures. Cartridges are extracted with carbonyl-free HPLC grade ACN. Field-collected cartridges must be removed from cold storage and allowed to equilibrate to room temperature, approximately 30 minutes, prior to extraction. Cartridges are removed from the foil pouch, the end caps are removed, and the cartridges are installed in a holding rack with the inlet of the cartridge pointed down to facilitate elution. Field-collected samples and associated field and laboratory QC samples discussed in Section 4.3.9.4.1 must be extracted in the same batch.

The ACN extraction solvent must be added to the cartridge so that elution occurs in the direction opposite of sample air flow (unless the laboratory can demonstrate that reverse elution is not necessary). Luer syringe barrels or other commercially-available funnels are available for use as solvent reservoirs for extraction, if needed. Elution may be performed by gravity or vacuum methods. The cartridge eluent is collected in a clean volumetric flask or other appropriate volumetrically certified vessel. Once the eluent is collected, the extract is brought to a known final volume with ACN extraction solvent.

A minimum 2-mL extraction volume is necessary to ensure complete elution of the target analytes from the sorbent bed. An extraction volume up to 5 mL may be employed, however larger volumes do not increase the extraction efficiency and may overly dilute the extract.

Once brought to volume, it is highly recommended that an aliquot of the extract is transferred to an autosampler vial for analysis and the remaining extract stored in a sealed vial protected from light at $\leq 4^{\circ}\text{C}$. The stored extract affords reanalysis if there are problems during analysis (up to 40 days from extraction).

4.3.9.5 Analysis by HPLC

4.3.9.5.1 Instrumentation Specifications. For separation of the DNPH-carbonyls by HPLC, the analytical system must have the following components:

- Separations module capable of precise pumping of ACN, methanol, and/or deionized water at 1 to 2 mL/min
- Analytical column, C18 reversed phase, $4.6 \times 50\text{-mm}$, $1.8\text{-}\mu\text{m}$, or equivalent
- Guard column
- Absorbance detector set to 360 nm or mass selective detector capable of scanning m/z range of 25 to 600
- Column heater capable of maintaining $25\text{-}35 \pm 1^{\circ}\text{C}$
- Degassing unit

4.3.9.5.2 Initial Calibration. On each day that analysis is performed, the instrument must be calibrated (meaning an ICAL must be performed) or the ICAL must be verified by analysis of a CCV according to the following guidance.

ICAL of the HPLC must be performed initially, when continuing calibration checks fail criteria, and when there are major changes to the instrument which affect the response of the instrument. Such changes include, but are not limited to: change of guard or analytical column (if analyte retention times change), backflushing of the analytical column (if analyte retention times change), replacement of pump mixing valves and/or seals (if analyte retention times change), replacement of the detector and/or lamp, and cleaning of the MS source (if HPLC/MS).

Working calibration standards are prepared in ACN at concentrations covering the desired working range of the detector, typically from approximately 0.01 to 3.0 $\mu\text{g/mL}$ of the free carbonyl. In order to avoid confusion or error in concentration calculation, it is recommended that all concentrations be expressed as the free carbonyl and not the DNPH-carbonyl. The ICAL must consist of a minimum of five calibration standard levels which cover the entire calibration range.

Prior to calibrating the HPLC, the instrument must be warmed up and mobile phase should be pumped for a time sufficient to establish a stable baseline. All solutions to be analyzed must be removed from cold storage and equilibrated to room temperature prior to analysis.

Once a stable baseline is established, minimally one solvent blank (SB, an aliquot of extraction solvent dispensed directly into a vial suitable for the HPLC autosampler, or similar) must be analyzed to demonstrate the instrument is sufficiently clean, after which analysis of calibration standard solutions may commence. The SB must show target compound responses are less than the laboratory MDL_{sp} for MDLs determined via Section 4.1.3.1 or the $s \cdot K$ portion of the MDL for MDLs determined via Section 4.1.3.2.

To establish the ICAL, each standard solution must be injected minimally once and preferably in triplicate. The instrument response (area units) is plotted on the y-axis against the nominal concentration on the x-axis and the calibration curve generated by linear regression for each target compound. The calibration curve correlation coefficient (r) must be ≥ 0.999 for linear fit and the curve must not be forced through the origin. The calculated concentration of each calibration solution must be within 20% of its nominal concentration.

The absolute value of the concentration equivalent to the intercept of the calibration curve ($|\text{intercept}/\text{slope}|$) converted to concentration units (by division by the slope) must be less than the laboratory MDL_{sp} for MDLs determined via Section 4.1.3.1 or the $s \cdot K$ portion of the MDL for MDLs determined via Section 4.1.3.2. When this specification is not met, the source of contamination or suppression must be corrected and the calibration curve reestablished before sample analysis may commence.

RT windows are calculated from the ICAL by determining the mean RT for each target compound. For positive identification the RT of a derivatized carbonyl must be within three standard deviations ($3s$) or $\pm 2\%$, whichever is smaller, of its mean RT from the ICAL. Note that

heating the column to a constant temperature of approximately 25 to 30°C promotes consistent RT response by minimization of column temperature fluctuations.

4.3.9.5.3 Secondary Source Calibration Verification Standard. Following each successful ICAL, a second SSCV must be analyzed to verify the accuracy of the ICAL. The SSCV is prepared in ACN at approximately the mid-range of the calibration curve by dilution of the secondary source stock standard. Alternatively, two or more concentrations of SSCV may be prepared covering the calibration range. All SSCVs must recover within $\pm 15\%$ of nominal.

4.3.9.5.4 Continuing Calibration Verification. Once the HPLC has met ICAL criteria and the ICAL verified by the SSCV, a CCV must be analyzed prior to the analysis of samples on days when an ICAL is not performed, and minimally every 12 hours of analysis. The CCV is also recommended to be analyzed after every 10 sample injections and at the end of the analytical sequence. On days when an ICAL is not performed, a SB must be analyzed prior to the CCV to demonstrate the instrument is sufficiently clean to commence analysis.

At a minimum, a CCV must be prepared at a single concentration recommended to be at approximately the mid-range or lower end of the calibration curve, must be diluted from the primary stock or secondary source stock material, and CCV recovery must be 85 to 115% for each target compound. As a best practice, two or more concentrations of CCV may be prepared and analyzed so as to better cover instrument performance across the range of the calibration curve.

Corrective action must be taken to address CCV failures, including, but not limited to, preparing and analyzing a new CCV, changing the guard or analytical column, backflushing of the analytical column, replacement of the detector and/or lamp (if HPLC/UV), and cleaning of the MS source (if HPLC/MS).

4.3.9.5.5 Replicate Analysis. For each analytical sequence of 20 or fewer field-collected samples, at least one field-collected sample extract should be selected for replicate analysis (as prescribed in the workplan). For sequences containing more than 20 field-collected samples, n such replicates must be analyzed, where $n = \text{batch size} / 20$, and where n is rounded to the next highest integer. Thus, for batch sizes of 30, two replicate analyses would be performed. Replicate analysis must demonstrate precision of $\leq 10\%$ RPD for concentrations ≥ 0.5 $\mu\text{g}/\text{cartridge}$.

4.3.9.5.6 Compound Identification. The following criteria must be met in order to positively identify a target compound:

1. The signal-to-noise (S:N) ratio of the target compound peak must be $> 3:1$, preferably $> 5:1$. Refer to Section 4.2.5.10.3 for more information on S:N.
2. The RT of the compound must be within the acceptable RT window determined from the ICAL average (see Section 4.3.9.5.2).
3. ****HPLC-MS only **** - The target and qualifier ion peaks must be co-maximized (peak apexes within one scan of each other). Refer to Section 4.2.5.10.3 for more information on co-maximization.

4. ****HPLC-MS only **** - The abundance ratio of the qualifier ion response to target ion response for at least one qualifier ion must be within $\pm 30\%$ of the average ratio from the ICAL. Refer to Section 4.2.5.10.3 for more information on ion abundances.

Item 1 above does not need to be evaluated closely with each identified peak. Rather the interpretation of the experienced analyst should weigh heavily on whether the peak meets the minimal signal-to-noise ratio. Item 2 above may be automated by the analysis software such that it is automatically flagged. RT windows must be updated with each new ICAL.

If any of these criteria (as applicable) are not met, the compound may not be positively identified. The only exception to this is when in the opinion of an experienced analyst the compound is positively identified. The rationale for such an exception must be documented.

4.3.9.5.7 Data Review and Concentration Calculations. Each chromatogram must be closely examined to ensure chromatographic peaks are appropriately resolved and integration does not include peak shoulders or inflections indicative of a coelution. The HPLC method may require modification to employ mobile phase gradient programming or other methods to resolve coeluting peaks.

Each chromatogram of an extracted cartridge (MB, LCS, LCSD, or any field-collected sample) must be examined to ensure a DNPH peak is present. Chromatograms in which the DNPH peak area is $<$ approximately 50% of the typical peak area of the laboratory QC samples must be investigated for potential compound misidentification due to the likely appearance of additional chromatographic peaks as a result of formation of side products from the consumption of the DNPH. This verification can be estimated and should be prescribed within the SOP or similar controlled document. Once sample identification is confirmed, field-collected samples must be qualified as estimated concentrations when entered into AQS since depletion of the DNPH to below 50% of typical levels indicates the potential for negative bias in the measured concentrations.

The concentrations of target carbonyls in unknown samples are calculated by relating the area response of the target carbonyl to the relationship derived in the calibration curve generated in Section 4.3.9.5.2.

Concentration results which exceed the instrument calibration range must be diluted and analyzed such that peak within the calibration range. The diluted result must be reported and the associated MDL adjusted accordingly by the dilution factor (the MDL multiplied by the dilution factor).

While TO-11A allows for blank subtraction, this is not an acceptable practice and results must not be corrected for solvent blank or MB levels. Concentrations exceeding acceptance criteria for these blanks must prompt investigation as to the source of contamination and associated field collected sample results may require qualification.

For sampling units which do not provide an integrated collection volume, the beginning and ending flows are averaged to calculate the collected air volume. For computer controlled

sampling units, the integrated collected volume is typically available from the data logging system. Sampled air volumes must be in standard conditions of temperature and pressure (STP), 25°C and 760 mm Hg. Sampling unit flows should be calibrated in flows at standard conditions so conversion from local conditions to standard flows is not necessary.

The air concentration in $\mu\text{g}/\text{m}^3$ of each target carbonyl is determined by multiplying the concentration in the extract by the final extract volume and dividing by the collected sample air volume at standard conditions of 25°C and 760 mm Hg:

$$C_A = \frac{C_t \cdot V_e}{V_A}$$

where:

- C_A = concentration of the target carbonyl in air ($\mu\text{g}/\text{m}^3$)
- C_t = concentration of the target carbonyl in the extract ($\mu\text{g}/\text{mL}$)
- V_e = final volume of extract (mL)
- V_A = volume of collected air at STP (m^3)

Carbonyls concentrations can also be calculated in ppbv by multiplying by a conversion factor based on the molecular weight of the target carbonyl at STP is calculated as follows:

$$CF = \frac{MW}{0.082059 \cdot 298.15}$$

where:

- CF = conversion factor ($\mu\text{g} \cdot \text{m}^{-3} \cdot \text{ppb}^{-1}$)
- MW = molecular weight of the target carbonyl (g/mol)

The air concentration of the target carbonyl in ppb is then calculated as follows:

$$C_{A,\text{ppb}} = \frac{C_A}{CF}$$

where:

- $C_{A,\text{ppb}}$ = concentration of the target carbonyl in air (ppb)
- C_A = concentration of the target carbonyl in air ($\mu\text{g}/\text{m}^3$)
- CF = conversion factor ($\mu\text{g} \cdot \text{m}^{-3} \cdot \text{ppb}^{-1}$)

4.3.10 Summary of Quality Control Parameters. A summary of QC parameters is shown in Table 4.3-4.

Table 4.3-4. Summary of Quality Control Parameters for NATTS Carbonyls Analysis

Parameter	Description and Details	Required Frequency	Acceptance Criteria
Solvent Blank (SB)	Aliquot of ACN analyzed to demonstrate instrument is sufficiently clean to begin analysis	Prior to ICAL and daily beginning CCV	All target carbonyls < MDL _{sp} (refer to Section 4.1.3.1) or $s \cdot K$ (refer to Section 4.1.3.2)
Initial Calibration (ICAL)	Analysis of a minimum of five calibration levels covering approximately 0.01 to 3.0 µg/mL	Initially, following failed CCV, or when changes to the instrument affect calibration response	Linear regression $r \geq 0.999$, the concentration of each target carbonyl at each calibration level must be within $\pm 20\%$ of nominal
Second Source Calibration Verification (SSCV)	Analysis of a second source standard at the mid-range of the calibration curve to verify curve accuracy	Immediately following each ICAL	Recovery of each target carbonyl within $\pm 15\%$ of nominal
Continuing Calibration Verification (CCV)	Analysis of a known standard at the mid-range of the calibration curve to verify ongoing instrument calibration	Prior to sample analysis on days when an ICAL is not performed, and minimally every 12 hours of analysis. Recommended following every 10 sample injections, and at the conclusion of each analytical sequence	Recovery of each target carbonyl within $\pm 15\%$ of nominal
Extraction Solvent Method Blank (ESMB)	Aliquot of extraction solvent analyzed to demonstrate extraction solvent is free of interferences and contamination	One with every extraction batch of 20 or fewer samples, at a frequency of no less than 5%	All target carbonyls < MDL _{sp} (refer to Section 4.1.3.1) or $s \cdot K$ (refer to Section 4.1.3.2)
Method Blank (MB)	Unexposed DNPH cartridge extracted as a sample	One with every extraction batch of 20 or fewer samples, at a frequency of no less than 5%	Criteria in Table 4.3-2 must be met
Laboratory Control Sample (LCS)	DNPH cartridge spiked with known amount of target analyte at approximately the lower third of the calibration curve	Minimally quarterly. Recommended: One with every extraction batch of 20 or fewer samples, at a frequency of no less than 5%	Formaldehyde recovery 80-120% of nominal spike All other target carbonyls must recover 70-130% of nominal spike
Laboratory Control Sample Duplicate (LCSD)	Duplicate LCS to evaluate precision through extraction and analysis	Minimally quarterly. Recommended: One with every extraction batch of 20 or fewer samples, at a frequency of no less than 5%	Must meet LCS recovery criteria Precision $\leq 20\%$ RPD of LCS
Replicate Analysis	Replicate analysis of a field-collected sample	Once with every analysis sequence of 20 or fewer samples, at a frequency of no less than 5% (as required by workplan)	Precision $\leq 10\%$ RPD for concentrations ≥ 0.5 µg/cartridge
Retention Time (RT)	RT of each target compound in each standard and sample	All qualitatively identified compounds	Each target carbonyl within $\pm 3s$ or $\pm 2\%$ of its mean ICAL RT

**Table 4.3-4. Summary of Quality Control Parameters for NATTS
Carbonyls Analysis (Continued)**

Parameter	Description and Details	Required Frequency	Acceptance Criteria
Lot Blank Evaluation	Determination of the background of the DNPH cartridge media	Minimum of 3 cartridges or 1% (whichever is greater) for each new lot of DNPH cartridge media	All cartridges must meet criteria in Table 4.3-2
Zero Certification Challenge	Clean gas sample collected over 24 hours to demonstrate the sampling unit does not impart positive bias	Annually	Each target carbonyl in the zero certification ≤ 0.2 ppb above reference sample
Field Blank	Blank DNPH cartridge exposed to field conditions for minimally 5 minutes in the primary sampling location	Monthly	Must meet criteria in Table 4.3-3
Duplicate Sample	Field sample collected through the same inlet probe as the primary sample	10% of primary samples for sites performing duplicate sample collection (as required by workplan)	Precision $\leq 20\%$ RPD of primary sample for concentrations ≥ 0.5 $\mu\text{g}/\text{cartridge}$
Collocated Sample	Field sample collected through a separate inlet probe from the primary sample	10% of primary samples for sites performing collocated sample collection (as required by workplan)	Precision $\leq 20\%$ RPD of primary sample for concentrations ≥ 0.5 $\mu\text{g}/\text{cartridge}$

4.3.11 References

1. *Determination of Formaldehyde in Ambient Air using Adsorbent Cartridges Followed by High Performance Liquid Chromatography (HPLC) [Active Sampling Methodology]*; EPA Compendium Method TO-11A; U.S. Environmental Protection Agency: January 1999. Available at (accessed October 19, 2016): <https://www3.epa.gov/ttnamti1/files/ambient/airtox/to-11ar.pdf>
2. MacGregor, I. C., Hanft, E. A., and Shelow, D. M. (2015). *Update on the Optimization of U.S. EPA Method TO-11A for the Measurement of Carbonyls in Ambient Air*. Paper presented at the National Ambient Air Monitoring Conference, St. Louis, MO, August 10, 2016.
3. Urone, P., & Ross, R. C. (1979). Pressure change effects on rotameter air flow rates. *Environmental Science & Technology*, 13(6), 732-734. doi: 10.1021/es60154a003
4. Steven Sai Hang Ho, Ho Sai Simon Ip, Kin Fai Ho, Wen-Ting Dai, Junji Cao, Louisa Pan Ting Ng. "Technical Note: Concerns on the Use of Ozone Scrubbers for Gaseous Carbonyl Measurement by DNPH-Coated Silica Gel Cartridge." *Aerosol and Air Quality Research*, 13: 1151-1160, 2013.
5. Care and Safe Handling of Laboratory Glassware. Corning Incorporated. RG-CI-101-REV2. 2011. Available at (accessed October 19, 2016): http://csmedia2.corning.com/LifeSciences/media/pdf/Care_and_Safe_Handling_Lab_Glassware_RG-CI-101Rev2.pdf

4.4 PM₁₀ Metals Sample Collection and Analysis

Each agency must codify in an appropriate quality systems document, such as an SOP, or equivalent, its procedures for performing PM₁₀ metals sampling, filter digestion, and digestate analysis. Various requirements and best practices for such are given in this section. Note that regardless of the specific procedures adopted, method performance specifications as given in Section 4.4.13 must be met.

4.4.1 Summary of Method. PM₁₀ metals are collected onto a filter by either a low volume or high volume air sampling method. Following completion of either sampling procedure, the filter, or portion thereof, is digested to liberate (dissolve) the desired elements by heating in acid, and the digestate is analyzed via ICP/MS per EPA Compendium Method IO-3.5.¹ Briefly, digestates are introduced to the ICP/MS through pneumatic nebulization into a radio frequency argon plasma where the elements in solution are desolvated, atomized, and ionized. The ions are extracted from the plasma by vacuum and separated on the basis of their mass-to-charge ratio by a quadrupole or TOF MS capable of a resolution of 1 amu at 5% peak height. An electron multiplier is applied to the ions transmission response and the resulting signal information recorded and processed by the data system.

The particle-bound metals in the air are collected with a commercially-available standalone air sampler fitted with a size-selective inlet (SSI) such that only particulate matter (PM) with a mass median aerodynamic diameter less than 10 µm is captured. Particles are deposited on either 47-mm Teflon[®] filter (low volume) or 8 inch × 10 inch QFF media over the 24-hour collection period. The low volume sampling method flow is set to 16.7 liters per minute (LPM; at local conditions) for a total collection volume of 24.05 m³. The high volume method flow is set to approximately 1.13 m³/min (at local conditions) for a total collection volume of approximately 1627 m³. For both low volume and high volume methods, the SSIs require a closely regulated flow rate to ensure PM cut points are accurate and temporally stable.

Following the completion of any desired gravimetric measurements for determining total PM₁₀ gravimetric concentration, the filters are digested for metals analysis. Following collection, filters should be stored at ambient conditions and must be digested and analyzed within 180 days.

The target metals of interest to the NATTS Program are listed in Table 4.4-1.

Table 4.4-1. NATTS Program Metals Elements and Associated CAS Numbers

Element	CAS Number
Antimony ^b	7440-36-0
Arsenic ^{a b}	7440-38-2
Beryllium ^{a b}	7440-41-7
Cadmium ^{a b}	7440-43-9
Chromium	7440-47-3
Cobalt ^b	7440-48-4
Lead ^{a b}	7439-92-1
Manganese ^{a b}	7439-96-5
Nickel ^{a b}	7440-02-0
Selenium ^b	7780-49-2

^a NATTS Tier I core analyte

^b NATTS PT target analyte

4.4.2 Advantages and Disadvantages of High Volume and Low Volume Sample Collection. Summarized below are some of the advantages and disadvantages of the high and low volume air sampling for PM₁₀ metals.

4.4.2.1 Low Volume Sampling

Advantages

- Many low volume samplers are already in use at PM monitoring sites to assess compliance with the National Ambient Air Quality Standards. As a result, many monitoring agencies are familiar with and have the infrastructure to support low volume PM sampling.
- Teflon[®] filters, as compared to QFFs, typically have lower background levels of metals such as chromium, nickel, manganese, and cobalt. As a result, MBs are cleaner and MDLs that account for MB levels are lower.
- Low volume instruments are available into which several filters may be simultaneously loaded so as to permit collection of several sampling events in sequence without the need for operator intervention.

Disadvantages

- The extraction and analysis method must have greater sensitivity and background contamination must be more strictly limited in order to achieve MDLs equivalent to high volume sampling, due to the lower total sample volume collected.
- The entire Teflon[®] filter is digested for analysis, thus error in preparation may require invalidation of results, and it not possible to prepare duplicate and/or spike duplicate field collected samples for QC purposes.

4.4.2.2 High Volume Sampling

Advantages

- At the listed flow rates, the high volume sampling method collects approximately 67 times more mass on the filter than low volume sampling, thereby providing greater

sensitivity (approximately seven-fold) for metals analysis even after taking into consideration that only a portion (typically approximately 1/9) of the QFF is digested for analysis.

- In the event of loss of the primary sample and when assessment of method precision and bias is desirable, duplicate and spike duplicate samples may be readily prepared by extraction and analysis of another filter field collected sample strip.

Disadvantages

- QFFs typically have higher background levels of target metals, such as chromium, nickel, manganese, and cobalt.
- Sequential sampling is not possible with high volume filter sampling instruments.

4.4.3 Minimizing Contamination, Filter Handling, and Filter Inspection

4.4.3.1 *Minimizing Contamination.* Careful handling of the filter media is required to ensure that metals measured on the filter are present as a result of sampling the ambient atmosphere, rather than due to contamination. Each agency must codify into an appropriate quality system document, such as an SOP, procedures that it will follow to minimize the introduction of metals contamination during filter handling, processing, extraction, and subsequent analysis of digestates. What follows in this section are practices either that are required or are recommended for adoption into an agency's quality system.

See also Section 4.4.6 for guidance on minimizing contamination during the preparation of labware.

4.4.3.2 *Filter Handling.* Filters must only be handled with gloved hands or plastic or Teflon[®]-coated forceps, and filter media must not be manipulated with metal tools. Tools for portioning filter strips must be ceramic or plastic. Forceps and work areas should be routinely decontaminated using a dilute nitric acid solution followed by rinses with deionized water. Use of volumetric syringes with metal needles must be avoided.

Teflon[®] filter media should be transported to and from the field in non-metallic cassettes which must be kept tightly capped except during installation of filters into sampling units. Placement of filters into, and subsequent removal of filters from cassettes should be performed in the laboratory in a clean area where measures are taken to control the levels of airborne particulate matter, such as a conditioning room for filter weighing. Such filter weighing rooms typically employ dust-reduction methods such as high efficiency particulate air (HEPA) filtration to minimize potential deposition contamination.

QFFs should be transported and maintained in manila or glassine envelopes which protect the filter from dust deposition and from physical damage. The filter should be placed into, and subsequently removed from, the cassette while the cassette is in a clean area, one without obvious dust contamination, away from visible sources of PM, and with minimal air movement. Following removal from the cassette after the conclusion of sampling, the filter must be folded lengthwise in half (with gloved hands) with the particulate matter inward, and placed into a

protective manila envelope or folder, or within a glassine envelope to protect the filter from loss of PM or from deposition of dust.

4.4.3.3 Filter Inspection. Filter media must be inspected for pinholes, discolorations, creases, thin spots, and other defects which would make them unsuitable for sample collection. Teflon[®] filters must additionally be inspected for separation of the support ring. Filters should be inspected on a light table or similar apparatus which allows backlighting of the filter to aid in the identification of defects. Any surface (such as the light table) coming into contact with the filter media must be decontaminated from dust and residue prior to use with deionized water and lint-free wipes. All filter handling requirements given in Section 4.4.3.2 must be followed.

4.4.4 Precision – Sample Collection and Laboratory Processing. Each agency must codify in an appropriate quality systems document, an SOP, or similar, procedures that it will follow to assess precision. Given below are the various types of precision and guidance on how to measure each.

4.4.4.1 Sample Collection Precision. Given that each PM₁₀ metals instrument consists of a discrete inlet and sampling pump, collection of duplicate samples is not possible. Thus, evaluation of the precision of the entire PM₁₀ metals sampling technique, from collection through extraction and analysis, may only be performed by way of collocated sampling.

For monitoring sites conducting collocated PM₁₀ metals sampling, collocated samples must be collected as minimally 10% of the primary samples collected (as prescribed in the workplan). This is equivalent to a minimum of six collocated samples for sites conducting one-in-six days sampling for a total of 61 primary samples annually. More frequent collocated sample collection provides additional sample collection precision and is encouraged where feasible.

Collocated sample results must show precision of $\leq 20\%$ RPD compared to the primary sample for concentrations $\geq 5x$ MDL. Root cause analysis must be performed for instances in which collocated samples fail this precision specification and the results of the primary and collocated sample must be qualified when entered into AQS.

4.4.4.2 Laboratory Precision

4.4.4.2.1 Low Volume Teflon[®] Filter Laboratory Precision. Teflon[®] filters must be extracted in their entirety. As a result, duplicate samples may not be prepared by subdividing a filter. However, the precision of filter digestion and analysis should be assessed by the preparation and analysis of duplicate LCSs. A sample digestate may be selected with each digestion batch to be analyzed in replicate to determine analytical precision. To summarize,

- A duplicate LCS informs the precision of digestion and analysis procedures, and
- Replicate analysis of a sample digestate provides precision for the analysis only.

4.4.4.2.2 High Volume QFF Laboratory Precision. Sample processing and analysis precision may be evaluated in several different ways with QFFs. For example, to evaluate the precision of the filter preparation, digestion, and analysis processes, duplicate strips

may be portioned from a field collected QFF filter and digested separately and duplicate LCSs may be prepared. Preparation, digestion, and analysis of a matrix spike (MS) and matrix spike duplicate (MSD) duplicate pair can additionally be performed to evaluate the matrix effects on precision of field collected samples. Finally, to determine analytical precision, a sample digestate may be analyzed in replicate. To summarize:

- Duplicate sample filter strips and duplicate LCSs provide precision of digestion and analysis procedures;
- Duplicate matrix spike filter strips provide information on the precision of digestion and analysis procedures, and include an assessment of potential matrix effects of that specific sample; and
- Replicate analysis of a sample digestate provides precision for the analysis only.

4.4.5 Field Blanks. For both high volume and low volume sampling methods, field blank samples must be collected minimally monthly for each primary sampling unit (total of 12 per year for a total of 18% of samples [12 out of 61]). For collocated sampling units, field blank samples should be collected minimally twice per year (two out of six) or for 18% of collocated samples collected, whichever is greater.

Field blanks must be generated by installing the field blank filter into the sampling unit to simulate a field sample, however the field blank does not experience sample flow. After minimally 5 minutes have elapsed (or the duration of sample switching required by the sampling unit, as applicable), the filter is retrieved and stored at the field site until the associated field sample can be retrieved and transported to the laboratory.

Field blank analysis must demonstrate all target elements < MDL.

An exposure blank is similar to a field blank, but is not required, and may be collected via several protocols. The exposure blank includes exposing the filter to the ambient conditions by installation in a sampling unit, and just like a field blank, air is not drawn through the exposure blank cartridge. The exposure blank filter sample may be installed in the primary sampling unit on non-sample collection days or could be installed in a collocated sampling unit during collection of the primary sample.

4.4.6 Labware Preparation for Digestion and Analysis. Regardless of how filters are digested, labware cleaning is essential to ensure background contamination is minimized. As with other contamination minimization procedures, each agency must codify in an appropriate quality systems document, such as an SOP, or equivalent, its procedures for effective cleaning and decontamination of labware. Regardless of the procedures adopted, method performance specifications as given in Section 4.4.13 must be met.

Labware for hot block digestions is typically single use; however, labware for microwave digestion and volumetric labware for preparation of standards and reagents must be effectively cleaned before each use. To do so, labware should be rinsed with tap water to remove as much of the previous contents as possible. Following this tap water rinse, labware should be soaked minimally overnight in a $\geq 10\%$ HNO₃ (v/v) aqueous solution. Soaking should be followed by a

minimum of three rinses with deionized water and air drying. Alternatively, labware cleaning instruments are commercially available which may be programmed to provide washing, rinsing, and soaking cycles in various detergent and acid solutions.

Volumetric labware must not be heated above 80 to 90°C as this voids the volumetric certification.² Clean labware should be stored in a contaminant-free area, upside down or capped to minimize introduction of contamination. Elevated levels in calibration blanks and digested reagent blanks indicate the presence of contamination. Additional cleaning and acid rinsing steps should be considered when blanks exceed the specified acceptance criteria.

4.4.7 Reagents for Metals Digestion and Analysis. Due to the sensitivity of ICP/MS instruments, the purity of reagents and standards is paramount. Reagents and standards must be certified and traceable with COAs, and it is recommended that all reagents and standards be of the greatest purity possible and have minimal background levels of target elements. Regardless of the reagents and standards selected, calibration and reagent blanks must meet method specifications as given in Section 4.4.13.

Reagent water for the preparation of digestion solutions and for dilution of standard materials should be ASTM Type I or equivalent (having an electrical resistivity greater than 18 MΩ·cm). Acids should be trace metals grade, ACS spectroscopic grade, UHP grade, or equivalent. Further polishing of reagent water and redistillation of acids may be necessary to achieve blank acceptance criteria. Borosilicate glass volumetric flasks and storage containers should be avoided. Teflon[®] or plastic (polyethylene, polypropylene, etc.) certified volumetric flasks and storage bottles are preferable as they do not leach contaminants into stored solutions. Solutions prepared in borosilicate glass volumetric flasks should be transferred as soon as possible to a Teflon[®] or plastic storage container.

4.4.8 Method Detection Limits. MDLs must be determined per the guidance provided in Section 4.1. Furthermore, MDLs must be determined with reagents, media, and sample handling techniques identical to those employed for the processing of field samples. Determined MDLs for Tier I core analytes must meet the requirements listed in the most recent workplan.

4.4.8.1 Teflon[®] Filter MDL. If the 40 CFR Part 136 Appendix B guidance in Section 4.1.3.1 is followed, Teflon[®] filter MDLs must be determined by digesting minimally seven spiked filters and seven method blank filters (all selected from the same lot of filters) in three temporally-separated and unique digestion and analytical batches. Both the MDL_{sp} and MDL_b must be tracked and documented. QC blanks, which are not prepared with the filter matrix, are compared to the MDL_{sp} regardless of whether it is reported as the laboratory MDL. Alternatively, MDLs may be determined following the procedure in Section 4.1.3.2. For laboratories determining MDLs according to Section 4.1.3.2, laboratories must track the portion of the MDL determined by $s \cdot K$ for comparison to QC blanks which are not prepared with the filter matrix.

4.4.8.2 QFF MDL. If the updated 40 CFR Part 136 Appendix B procedure in Section 4.1.3.1 is followed, QFF MDLs must be determined by digesting seven spiked filter strips and seven method blank filter strips in three temporally-separated and unique digestion and analytical batches. The filter strips should be from a different filter (from the same lot of filters) for each

batch. Both the MDL_{sp} and MDL_b must be tracked and documented. QC blanks, which are not prepared with the filter matrix, are compared to the MDL_{sp} regardless of whether it is reported as the laboratory MDL. Alternatively, MDLs may be determined following the procedure in Section 4.1.3.2. For laboratories determining MDLs according to Section 4.1.3.2, laboratories must track the portion of the MDL determined by $s \cdot K$ for comparison to QC blanks which are not prepared with the filter matrix.

4.4.9 Low Volume Sample Collection and Digestion

4.4.9.1 Air Sampling Instruments. Low volume sample collection instruments must comply with the Low-Volume PM₁₀ FRM requirements as listed in 40 CFR Part 50 Appendix L, i.e., they must operate at the design flow rate of 16.67 L/min (at local conditions), utilize 47-mm Teflon[®] filter collection media, and be fitted with the “pie plate” PM₁₀ inlet or the louvered inlet specified in 40 CFR 50 Appendix L, Figures L-2 through L-19, configured as in the PM₁₀ reference method. The following instruments are among those that comply with these specifications:

- Andersen Model RAAS10-100
- Andersen Model RAAS10-200
- Andersen Model RAAS10-300
- BGI Incorporated Model PQ100
- BGI Incorporated Model PQ200
- Opsi Model SM200
- Thermo Scientific or Rupprecht and Pataschnick Partisol Model 2000
- Thermo Scientific Partisol 2000-FRM
- Thermo Scientific Partisol or 2000i
- Rupprecht and Patashnick Partisol-FRM 2000
- Thermo Scientific Partisol-Plus Model 2025
- Thermo Fisher Scientific Partisol 2025i
- Rupprecht and Patashnick Partisol-Plus 2025
- Tisch Environmental Model TE-Wilbur10

Sampler siting requirements are listed in Section 2.4.

4.4.9.2 Flow Calibration. Sampling unit flow calibration must be performed minimally annually against a traceable calibrated flow transfer standard by adjusting the sampling unit flow to match the certified standard.

Moreover, the instrument flow should be checked minimally quarterly, recommended to be monthly, and per 40 CFR Part 50 Appendix L, the flow adjusted if it is not within $\pm 4\%$ of the transfer standard or within $\pm 5\%$ of the design flow rate. Prior to performing flow checks, sampling units should be leak checked to ensure that flow path integrity is maintained. A leak check should be performed minimally every five sample collection events. A successful leak check indicates a total flow of less than 80 mL or loss of less than 25 mm Hg.

4.4.9.3 Filter Media. Low volume PM₁₀ metals must be collected onto a 46.2-mm Teflon[®] filter substrate with a polypropylene support ring, 2- μ m pore size, and a particle deposit area of 11.86 cm². Filters must be stamped or printed with a unique identifier on either the support ring or on the filter substrate.³ EPA typically annually sends agencies the filter media.

4.4.9.3.1 Lot Background Determination. For each lot of filters, the concentration of metals in the lot background must be determined by digesting and analyzing five separate filters from a given lot.

While there is no prescribed threshold for the lot background concentration for each element, the lot blank concentrations must be reported to AQS. Note that the previous version of this TAD permitted lot blank subtraction provided results were flagged in AQS with the QA data qualifier “CB”, however lot blank subtraction is not permitted. AQS guidance is provided in Section 3.3.1.3.15.

4.4.9.4 Filter Sampling, Retrieval, Storage, and Shipment. Teflon[®] filters will likely arrive at the field site already installed in a cassette. The filter must be installed per the requirements of the specific low volume instrument. A leak check may then be performed followed by verification of the correct sampling date, duration, and target flow rate.

Upon sample retrieval, instrument performance information including the average temperature, barometric pressure, average flow, total collected volume, collection duration, and any flags indicating a problem during collection should be recorded, downloaded, or otherwise recorded, as appropriate. Following removal from the instrument, the covers are placed back onto the filter cassette, and the cassette sealed into a resealable plastic bag. Filters need not be shipped or stored refrigerated. Filters must be handled per the procedures in Section 4.4.3.1. The sample custody form must be completed and accompany the collected sample at all times until relinquished to the laboratory. COC documentation must comply with Section 3.3.1.3.7.

4.4.9.4.1 Sampling Schedule and Duration. Metals sample collection must be performed on a 1-in-6 days schedule for 24 ± 1 hours beginning at midnight and concluding at midnight of the following day, standard time (unadjusted for daylight savings time), as per the national sampling calendar. For missed or invalidated samples, a make-up sample should be scheduled and collected per Section 2.1.2.1. Clock timers controlling sampling unit operation must be adjusted so that digital timers are within ± 5 minutes of the reference time (cellular phone, GPS, or similar accurate clock) and mechanical timers within ± 15 minutes.

4.4.9.5 Teflon[®] Filter Digestion

4.4.9.5.1 Laboratory Digestion QC Samples. Each sample digestion batch must consist of 20 or fewer field-collected filters (primary samples, collocated samples, and field blanks). The following laboratory QC is required with each digestion batch:

- Negative Control Samples (Blanks), one each:
 - o Reagent Blank (RB) – digestion solution with no filter
 - o MB – blank filter with digestion solution

- Positive Control Samples (Spikes), one each:
 - o Reagent Blank Spike (RBS) – spiked digestion solution with no filter
 - o LCS – spiked blank filter with digestion solution
 - o LCSD – duplicate spiked blank filter with digestion solution

Laboratory QC samples must be processed, digested, and analyzed identically to field-collected samples, including, if applicable, filtration and/or centrifugation of digestates.

4.4.9.5.2 Digestion Procedure. Filter must be digested with one of three possible methods: hot block digestion, microwave digestion, or heated sonication. The three different techniques are described in the following sections.

4.4.9.5.2.1 Hot Block Digestion

The hot block digestion wells must be checked to ensure each reaches and is able to maintain the target digestion temperature initially when put into use and annually thereafter. To do so, the hot block is set to the target temperature (typically 95°C) and, after the temperature has been reached, a digestion vessel filled with deionized water, known as a temperature blank, is placed into each well. After approximately 5 minutes (or long enough for the temperature to stabilize), the temperature of the water in each temperature blank is measured. Temperatures across the block should be within $\pm 5^\circ\text{C}$ of the target temperature setting.

To perform digestion of Teflon[®] filters, each is placed into a separate digestion vessel. Certified single-use metals-free vessels with certified volumetric graduations are commercially available for hot block digestions and other vessels may be utilized provided they meet the required blank specifications. The lot and manufacturer of the digestion vessels must be documented with each batch. Sufficient digestion solution must be added to each vessel so as to completely submerge the filter. Digestion solutions typically consist of approximately 2% (v/v) nitric acid (HNO₃) and 0.5% (v/v) hydrochloric acid (HCl). To assist in the recovery of antimony, it may be necessary to add 0.1% hydrofluoric acid (HF) to the digestion solution.

The hot block digester is powered on and warmed to the desired temperature (~95°C) prior to placing each digestion vessel into a digestion well. Each digestion vessel should be covered with a precleaned ribbed watch glass and the batch of filters should be digested for a recommended for 2.5 hours, though digestion must be for a minimum of 30 minutes. Note that this duration of digestion must be consistent from batch to batch. An automatic shutoff timer can ensure consistent digestion duration. A temperature blank must be included with each batch to ensure that the proper temperature is reached during the digestion period. Digestion vessels should be observed periodically throughout digestion to ensure none go to dryness and that the filters remain submerged. Deionized water should be added to digestion vessels to avoid going to dryness. Filters which float should be resubmerged with a clean plastic or Teflon[®] stirring rod.

Once digestion has completed, digestion vessels are removed from the block and cooled to room temperature (approximately 30 minutes). Once cooled, the walls of the digestion vessel should be rinsed down with approximately 10 mL of deionized water and the digestates should be allowed to settle for minimally 30 minutes. Following settling, digestates must be brought to their final volume with deionized water. The final volume may be measured with the graduations on the volumetrically-certified digestion vessel. Otherwise, digestates must be transferred to a Class A volumetric vessel and the digestion vessel must be rinsed several times with small (2 to 3 mL) volumes of deionized water to ensure a quantitative transfer. The transferred digestates must be then brought to volume with deionized water.

For transfer of aliquots for analysis, filtration or centrifugation may be necessary to eliminate particulate interference on the ICP/MS. All such processing steps must be performed on both the field-collected and laboratory batch QC samples.

4.4.9.5.2.2 Microwave Digestion

Microwave digestion has several disadvantages when compared to hot block digestion. For example, microwave digestion equipment and accessories are expensive. Digestion vessels and associated caps must be cleaned and decontaminated after each use. Microwave oven power must be calibrated on a specified, periodic basis to ensure that the digestion energy is appropriate, comparable, and stable from batch to batch. Calibration frequency should not exceed six months and a best practice is to verify microwave power monthly. To ensure the appropriate amount of heat is imparted to vessels in an incompletely filled digestion rack, blank vessels may need to be added or the microwave power may need to be reduced. Due to the higher pressure and temperature, digestion vessels may overpressurize and explode, resulting in loss of sample and possible injury to laboratory staff. While such is possible, modern microwave digestion units typically employ temperature and pressure monitoring to adjust the power to reduce the likelihood of explosion.

The advantages of microwave compared to hot block digestion are that digestion may be performed more quickly (in approximately 30 minutes), digestions are more reproducible due to the even heating, the closed digestion vessels ensure no loss of volatile analytes such as mercury and lead and decrease the likelihood of the introduction of external contamination, and digestions are more complete as a result of the increased temperature and pressure.

To digest air filter samples by microwave digestion the microwave program should permit ramping the temperature to 180°C over 10 minutes and holding at 180°C for 10 minutes followed by a 5-minute cool down. Other programs are also acceptable provided the requisite batch QC criteria are met.

For digestion, each Teflon[®] filter must be placed into a separate microwave digestion vessel. Sufficient digestion solution must be added to each vessel so as to completely submerge the filter. Digestion solutions typically consist of approximately 2% (v/v) HNO₃ and 0.5% (v/v) HCl. Addition of a small amount (~0.1%) of hydrofluoric acid (HF) to the digestion solution may be needed to maintain antimony in solution.

The vessel caps and pressure relief valves are installed on the microwave digestion vessels and each vessel weighed to the nearest 0.01 g with a calibrated analytical balance. Weighed digestion vessels are then installed in the carousel in the microwave. The microwave digestion program is run concluding with a cool down. At the end of the program, the microwave status should be checked to verify the program completed appropriately and the digestion vessel carousel is carefully removed from the microwave oven and allowed to cool in a fume hood. Once cooled, vessels must be weighed to the nearest 0.01 g to ensure no loss of sample. Vessels which exhibit mass loss of > 0.01 g must be invalidated or, minimally, their analysis results must be flagged. Once cooled and weighed, vessels may be opened. Caution must be used when opening vessels as the contents may still be under pressure.

After cooling, the walls of the digestion vessel should be rinsed down with approximately 10 mL of deionized water and the digestates should be allowed to settle for minimally 30 minutes. Following settling, digestates must be transferred to a Class A volumetric vessel and the digestion vessel rinsed several times with small (2 to 3 mL) volumes of deionized water to complete the quantitative transfer. The digestates are brought to volume with deionized water.

For transfer of aliquots for analysis, filtration or centrifugation may be necessary to eliminate particulate interference on the ICP/MS. All such processing steps must be performed on both the field-collected and laboratory batch QC samples.

4.4.9.5.2.3 Acid Sonication

Each filter is placed into a separate digestion vessel. Certified single-use metals-free vessels with certified volumetric graduations are commercially available and other vessels may be utilized provided they meet the required blank specifications. The lot and manufacturer of the digestion vessels must be documented with each batch. Sufficient 4% (v/v) HNO₃ digestion solution is added to each vessel so as to completely submerge the filter. Addition of a small amount (~0.1%) of hydrofluoric acid (HF) to the digestion solution may be needed to maintain antimony in solution.

The sonication bath is powered on and warmed to the desired temperature (~69°C) prior to placing the digestion vessels into the bath. Each digestion vessel should be capped and sonicated for a minimum of 3 hours. Digestion vessels should be observed periodically throughout digestion to ensure the filter remains submerged. Filters which float should be resubmerged with a clean plastic or Teflon[®] stirring rod.

Once the digestion program has completed, digestion vessels are removed from the bath and cooled. Once cooled, the walls of the digestion vessel should be rinsed down with approximately 10 mL of deionized water and the digestates should be allowed to settle for minimally 30 minutes. Following settling, digestates must be brought to their final volume with deionized water. The final volume may be measured with the graduations on the volumetrically-certified digestion vessel. Otherwise, digestates are transferred to a Class A volumetric vessel and the digestion vessel are rinsed several times with small (2-3 mL) volumes of deionized water to ensure a quantitative transfer. The transferred digestates are then brought to volume with

deionized water.

For transfer of aliquots for analysis, filtration or centrifugation may be necessary to eliminate particulate interference on the ICP/MS. All such processing steps must be performed on both the field-collected and laboratory batch QC samples.

4.4.10 High Volume Sample Collection and Digestion

4.4.10.1 Air Sampling Instruments. High volume sample collection instruments must comply with the High-Volume PM₁₀ FRM requirements in 40 CFR Part 50 Appendix J, i.e., they must operate at a design flow rate of 1.13 m³ (at local conditions), utilize 8 inch × 10 inch QFF collection media, and be fitted with the PM₁₀ inlet per EPA Reference Method RFPS-0202-141, RFPS-1287-063, or equivalent. The following sampling units are among those that comply with these specifications:

- Ecotech Model 3000
- Graseby Andersen/GMW Model 1200
- Graseby Andersen/GMW Model 321-B
- Graseby Andersen/GMW Model 321-C
- Tisch Environmental Model TE-6070 or New Star Environmental Model NS-6070
- Wedding and Associates or Thermo Environmental Instruments Inc. Model 600

Sampler siting requirements are listed in Section 2.4.

4.4.10.2 Flow Calibration. Sampling unit flow calibration must be performed minimally annually against a traceable calibrated flow transfer standard by adjusting the sampling unit flow to match the certified standard.

Moreover, the instrument flow should be checked minimally quarterly, recommended to be monthly, and the flow adjusted if it is not within $\pm 7\%$ of the transfer standard or within $\pm 10\%$ of the design flow rate. Prior to performing flow checks, sampling units should be leak checked to ensure that flow path integrity is maintained. Leak checks are performed by installing a piece of polycarbonate or other suitable substrate to seal off the filter plate and briefly operating the sampling unit motor. If a high-pitched whistle is heard, there is a leak in the flow path which must be remedied before sample collection can commence. Leak checks should be performed approximately every fifth sample collection event.

4.4.10.3 Filter Media. Sampling media consist of 8 inch × 10 inch QFF substrate with a 2- μ m pore size, capable of 99% particle sampling efficiency for particles 0.3 μ m in diameter or larger. Filters must be stamped or printed with a unique identifier on the corner of the filter and are typically provided annually by EPA.⁴

4.4.10.3.1 Lot Background Determination. For each lot of filters, the concentration of metals in the lot background must be determined by digesting and analyzing five filter strips, each cut from a separate filter from a given lot of filters. For monitoring agencies contracting

analysis, filters for lot blanks should be supplied to the laboratory to determine the lot background.

QFFs typically have background levels higher than Teflon[®] filters; chromium, cobalt, lead, manganese, and nickel may be routinely found. Note that the previous version of this TAD permitted lot blank subtraction provided results were flagged in AQS with the QA data qualifier “CB”, however lot blank subtraction is not permitted.

While there is no prescribed threshold for the lot background concentration for each element, the lot blank concentrations must be reported to AQS. Information on reporting to AQS may be found in section 3.3.1.3.15.

4.4.10.4 Filter Sampling, Retrieval, Storage, and Shipment. Filter media may be installed in a sampling cassette at the laboratory before shipment to the field, or the site operator may be required to install the filter into the cassette. Installation of the filter into the cassette must be performed in a clean (minimal dust) indoor environment, preferably protected from air movement, with the filter identifier oriented downward. A cover should be attached to the top of the cassette to protect the filter sampling surface. Storing the assembled filter and cassette in a sealed plastic bag during transport and storage is a best practice.

The cam-lock bolts of the size-selective inlet on the sampling unit are loosened to allow the inlet to open on the hinge and the inlet locked open using a prop. The swing bolts are then loosened to allow the assembled cassette and filter to be installed. Installation must be performed carefully to ensure that the rubber gasket on the base of the sampling unit forms a tight seal around the cassette. The swing bolts are then tightened in a diagonal pattern to ensure even pressure is applied to the cassette. Each time a sample is set up, the inside of the sampling head and mating surfaces should be given a quick visual inspection for loose debris or corrosion which could impact the filter and the integrity of the gasket on the size-selective inlet. Once the cassette is installed, the inlet is closed and secured to the body of the sampling unit using the cam-lock bolts.

If the sampling unit is equipped with electronic flow control to automatically adjust flow rate based on ambient temperature and pressure, the sample schedule program must be verified before the sampling unit is ready for collection. If the sampling unit is not equipped with electronic flow control, the sampling unit must be powered on and allowed to run for minimally five minutes (ten minutes are recommended) before a reading of the pressure drop across the flow venturi, which must be cross-referenced to a corresponding calibrated flow. The unit is then powered off and the sample schedule program verified.

Upon sample retrieval, instrument performance information including the average temperature, barometric pressure, average flow, total collected volume, collection duration, and any flags indicating a problem during collection should be recorded, downloaded, or otherwise recorded, as appropriate. For sampling units without electronic flow control, the sampling unit must be powered on and allowed to run for minimally five minutes (ten minutes are recommended) before recording the reading of the pressure drop across the flow venturi. The filter sample cassette is then removed from the sampling unit and the cover placed on the cassette (it is a best

practice to place the filter cassette into a resealable plastic bag) until the filter may be removed from the cassette in a clean area, free of obvious contamination, and with minimal air movement.

When removed from the cassette, the filter must be folded in half, lengthwise, with the particulate matter inward. Folding the filter lengthwise is the best way to ensure that the portioned filter strips include a portion of the fold. The folded filter must then be placed within a manila or glassine envelope for transportation to the laboratory. Alternatively, the cover may be replaced on the filter cassette and the cassette placed in a resealable plastic bag for transportation to the laboratory where the filter is removed. Filters need not be shipped or stored cold. Filters must be handled per the procedures in Section 4.4.3.1. The sample custody form must be completed and accompany the collected sample at all times until relinquished to the laboratory. COC documentation must comply with Section 3.3.1.3.7.

4.4.10.4.1 Sampling Schedule and Duration. Metals sample collection must be performed on a 1-in-6 days schedule for 24 ± 1 hours beginning at midnight and concluding at midnight of the following day, standard local time (unadjusted for daylight savings time), per the national sampling calendar. For missed or invalidated samples, a make-up sample should be scheduled and collected per Section 2.1.2.1. Clock timers controlling sampling unit operation must be adjusted so that digital timers are within ± 5 minutes of the reference time (cellular phone, GPS, or similar accurate clock) and mechanical timers within ± 15 minutes.

4.4.10.5 QFF Digestion

4.4.10.5.1 Laboratory Digestion QC Samples. Each sample digestion batch must consist of 20 or fewer field-collected filters (primary samples, collocated samples, and field blanks). The following laboratory QC is required with each digestion batch:

- Negative Control Samples (Blanks), one each:
 - o Reagent Blank – digestion solution only (no filter strip)
 - o Method Blank – blank filter strip with digestion solution

- Positive Control Samples (Spikes), one each:
 - o RBS – spiked digestion solution only (no filter strip – ensures proper spike recovery without the filter matrix)
 - o LCS – spiked blank filter strip with digestion solution (evaluates proper spike recovery with blank filter matrix)
 - o LCSD – (optional) duplicate spiked blank filter strip with digestion solution (evaluates precision of proper spike recovery with blank filter matrix)

- Matrix QC Samples, one each:
 - o Duplicate Sample Strip – An additional strip cut from a collected field sample (evaluates precision of the sample result and digestion process)
 - o Matrix Spike – An additional strip cut from a collected field sample which is spiked at the same concentration as the LCS (provides information on matrix effects on spike recovery)

- Matrix Spike Duplicate – An additional strip cut from a collected field sample which is spiked at the same concentration as the LCS (provides precision information on matrix effects on spike recovery)

4.4.10.5.2 Digestion Procedure. Prior to digestion, filter samples must be examined for damage to the filter or other defects (presence of insects, large visible particulates, etc.) which may affect sample integrity or analysis results. Following inspection, the requisite number of filter strips is to be cut from each filter to complete the digestion batch as listed above in Section 4.4.10.5.1.

Sampled 8 inch × 10 inch QFF media have an exposed filter area of 7 inch × 9 inch, leaving a ½-inch border of unsampled area around the entire filter. Strips for digestion should be cut perpendicular to the fold line for filters folded lengthwise as shown in Figure 4.4-1 and must not include the unsampled ½ inch × 8 inch border section at each end (left and right in Figure 4.4-1). This results in a 1 inch × 7 inch exposed section of the filter for each strip, equivalent to 1/9 of the 63 in² exposed filter area. Other conventions for portioning filter strips are acceptable so long as they include 7 in² of exposed filter area and a portion of the fold.

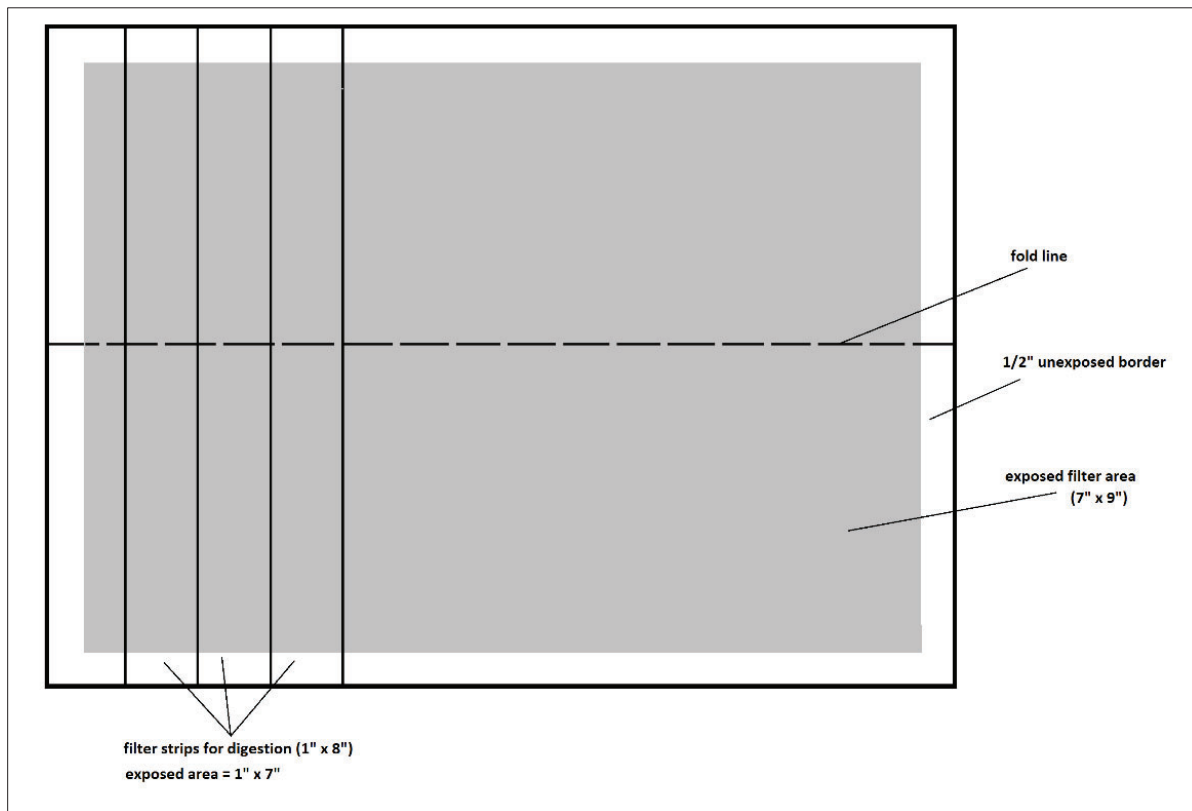

Figure 4.4-1. Portioning of QFF Strips for Digestion

Filter sample strips may be digested using one of three methods: hot block digestion, microwave digestion, or heated sonication.

4.4.10.5.2.1 Hot Block Digestion

Each filter strip must be accordion folded or coiled and placed into separate digestion vessels. Otherwise follow procedures as given in Section 4.4.9.5.2.1. Note that HF acid is not recommended for digestion of QFFs.

4.4.10.5.2.2 High Volume QFF Microwave Digestion

Each filter strip must be accordion folded or coiled and placed into separate digestion vessels. Otherwise follow procedures as given in Section 4.4.9.5.2.2. Note that HF acid is not recommended for digestion of QFFs.

4.4.10.5.2.3 High Volume QFF Acid Sonication

Each filter strip must be accordion folded or coiled and placed into separate digestion vessels. Otherwise follow procedures as given in Section 4.4.9.5.2.3. Note that HF acid is not recommended for digestion of QFFs.

4.4.11 PM₁₀ Metals Analysis by ICP/MS – EPA IO-3.5

4.4.11.1 ICP/MS Instrumentation. In order to achieve the necessary sensitivity, PM₁₀ metals for NATTS Program work must be analyzed via ICP/MS. Analysis via ICP-atomic emission spectroscopy (ICP-AES), graphite furnace atomic absorption (GFAA), or flame atomic absorption (FAA) is insufficiently sensitive and not permitted. ICP/MS instruments may be equipped with either a quadrupole MS or a TOF MS. For either system of MS, the general operation of the ICP is common and subject to the same interferences. The chosen instrument must have the capability to minimally scan for masses ranging from 7 to 238 amu.

4.4.11.2 ICP/MS Interferences. ICP/MS instruments are susceptible to interferences which can result in bias or saturation effects which overload the detector and require an extended period to bring detector response back into the acceptable sensitivity range. Such interferences are explained in more detail below.

- Isobaric interferences are caused by isotopes of different elements which have the same mass number as a target element. This results in a high bias for the target element, but such biases may be corrected with standard equations in ICP/MS software.
- Polyatomic, or molecular interferences are caused by combination of ions to form molecular ions which have the same mass as a target element. These interferences can result in high or low bias depending on the target element. Use of a collision reaction cell to remove polyatomic interferences upstream of the MS detector can greatly reduce or completely eliminate the effect of the interference.
- Transport interferences are a result of matrix effects which alters aerosol formation and results in changes to solution nebulization at the plasma. These interferences are typically not an issue with air filter analysis as the concentration of dissolved solids in digestates is fairly consistent from sample to sample.

- Matrix interferences are due to a chemical component in the solution which causes suppression or enhancement of the measured signal. This interference can be addressed by utilization of an internal standard or by diluting the sample digestate to minimize the impact of the interference.
- Memory, or carryover, interferences can occur when solutions of very high concentrations are analyzed. The high concentration may be difficult to effectively rinse from the ICP/MS sample introduction pathway resulting in contamination of subsequent solutions or in the electron multiplier becoming saturated resulting in a “burn in” where response factors of the ICP/MS are affected requiring substantial time for sensitivity to return. Extensive rinsing times and/or recalibration may be necessary to resolve such interferences.

4.4.11.3 Preparation of Calibration Standards for ICP/MS Analysis. Due to the instrument sensitivity effects of dissolved solids, the matrix of standard solutions must exactly match that of the final analyzed digestates. For example, if the final concentrations of acids in the analyzed digestates are 2% (v/v) nitric acid, 0.5% (v/v) hydrochloric acid, and 0.1% (v/v) hydrofluoric acid when samples are brought to volume, the acid concentrations in standard solutions must also be 2%, 0.5%, and 0.1%, respectively.

Aliquots of the stock standard solutions must be delivered with a Class A pipette or calibrated mechanical pipettor. All standard solutions must be brought to final volume in a Class A volumetric flask or equivalent Class A labware.

Stock single or multi-element solutions may be purchased commercially at certified concentrations in dilute nitric acid (typically 3% v/v) which are conveniently diluted to working concentration levels. Alternatively, stock solutions may be prepared gravimetrically by weighing appropriate amounts of high purity element solids and dissolving them into dilute nitric acid.

4.4.11.3.1 Primary Calibration Standards. Multi-element calibration standard solutions are prepared by diluting primary certified stock standard solutions in dilute nitric acid (typically 2% v/v). Calibration standard levels must cover a minimum of three non-zero concentrations spanning the desired concentration range (typically 0.1 to 250 µg/L depending on the element), however five levels are strongly recommended. These standard solutions are analyzed to generate the ICAL.

4.4.11.3.2 Secondary Source Calibration Verification Standard. A SSCV standard solution, also referred to as the QC sample, must be prepared by dilution of the secondary source stock standard solution with nitric acid (typically 2% v/v) to minimally a single concentration approximately at the mid-range of the curve. Preparation of the SSCV at three different concentrations covering approximately the lower third, mid-range, and upper third of the calibration range is a best practice and is recommended. This secondary source standard must be purchased from a different supplier. The SSCV stock may only be a different lot from the same supplier if unavailable from another supplier.

4.4.11.4 Internal Standards. ICP/MS analysis must include the evaluation of ISs to monitor ion response of analyzed solutions and to correct for instrumental drift and matrix interferences. A minimum of three IS elements must be co-analyzed with each solution. Suggested IS elements include Bi, Ge, In, ⁶Li, Sc, Tb, ⁶⁹Ga, Rh, and Y.

As relative responses of the target elements and IS elements are used to determine the final concentration of the elements in solution, the concentration of the IS must be the same for each analyzed solution. To achieve such, a known volume of the IS at a known concentration may be added to a known volume of each solution to be analyzed, or the IS may be added to each analyzed solution via a mixing coil on the ICP/MS sample introduction system. Further, IS concentrations should approximate those in the analyzed samples. A concentration of no more than 200 µg/L is recommended.

As with the calibration stocks, acids, and reagent water, the IS stock solution must be from a high purity source so as to minimize background levels of target elements.

IS responses must be monitored throughout the analysis and must be within 60 to 125% of the response of the initial calibration blank (ICB). For samples or solutions which show responses outside of this range, the instrument should be investigated to be sure the response change is not due to instrument drift. Instrument drift causing failures in IS response require retuning of the instrument and recalibration prior to continuing sample analysis.

4.4.11.5 Tuning Solutions. A tuning solution must contain elements covering the mass range of interest so that the ICP/MS may be tuned and mass calibration and resolution checks may be performed. A typical tuning stock solution contains isotopes of Li, Mg, Y, Ce, Tl, and Co at approximately 10 mg/L and is diluted so that final concentrations are approximately 100 µg/L or less for each element.

4.4.11.6 ICP/MS Warm Up, MS Tuning, and Setup. The ICP/MS must be warmed up for a minimum of 30 minutes, or a duration prescribed by the manufacturer, prior to use. The tuning solution must be analyzed to perform mass calibration and resolution checks, which may be performed during the warm up period. The MS must be optimized to provide a minimum resolution of approximately 0.75 amu at 5% peak height and mass calibration within 0.1 amu of unit mass. At a minimum five aliquots of the tuning solution must be analyzed and absolute signal relative standard deviation for each analyte of ≤ 5% must be achieved. Manufacturer tuning recommendations may also be followed.

Standard, blank, and sample solutions should be aspirated for a minimum of 30 seconds to equilibrate the ICP/MS response prior to acquiring data. Accelerated sample introduction systems may lessen this equilibration time. The ICP/MS must be set up such that three replicate integrations are performed for each analyzed solution. Each analysis result must be the average of these replicate integrations.

A rinse blank of 2% nitric acid in deionized water should be used to flush the system between analyzed solutions. The rinse blank solution should be aspirated for a sufficient time to ensure complete return to baseline before the next sample, standard, or blank introduction. Depending

on the sample introduction system, this may take approximately 60 seconds. Sample introduction systems that increase the rinse blank speed are available to decrease rinse times.

4.4.11.7 ICP/MS Calibration and Analytical Sequence Batch. On each day that analysis is performed, the instrument must be calibrated and the analysis batch QC samples listed in the following subsections must be analyzed. Calibration acceptance criteria are given in the following sections and are summarized in Section 4.4.13.

An example analysis sequence is given in Table 4.4-2.

Table 4.4-2. Example ICP/MS Analysis Sequence

Sequence Number	Solution Analyzed	Sequence Number	Solution Analyzed
1	Tuning solution	26	field sample 6
2	ICB	27	field sample 7
3	ICAL 1(lowest concentration)	28	field sample 8
4	ICAL 2	29	field sample 9
5	ICAL 3(highest concentration)	30	field sample 7
6	ICV	31	field sample 8
7	ICB	32	field sample 9
8	ICS B	33	field sample 10
9	ICS A	34	field sample 11
10	CCV	35	field sample 12
11	CCB	36	field sample 13
12	RB	37	CCV
13	MB	38	CCB
14	LCS	39	field sample 14
15	LCSD	40	field sample 15
16	field sample 1	41	field sample 16
17	duplicate (field sample 1)	42	field sample 17
18	matrix spike (field sample 1)	43	field sample 18
19	matrix spike duplicate (field sample 1)	44	field sample 19
20	field sample 2	45	replicate analysis (field sample 16)
21	field sample 3	46	1:5 serial dilution (field sample 19)
22	CCV	47	ICS B
23	CCB	48	ICS A
24	field sample 4	49	CCV
25	field sample 5	50	CCB

4.4.11.7.1 Initial Calibration. Once the mass calibration and tuning have met the criteria listed in Section 4.4.11.6, the response of the instrument must be calibrated for the elements of interest. Analyze the initial calibration blank (ICB, an undigested reagent blank) followed by the calibration standard solutions. The calibration curve must include the ICB as the zero concentration standard. Linear regression must be performed on the calibration solution responses and must show appropriate linearity and the curve fit must have a correlation coefficient (r) of 0.995 or greater. Replicate analyses of the calibration standards must show %RSD \leq 10%.

4.4.11.7.2 Initial Calibration Verification. Once the calibration curve is established, the SSCV (or QC sample) must be analyzed as the initial calibration verification (ICV) and must recover within $\pm 10\%$ of the nominal value.

4.4.11.7.3 Initial Calibration Blank. The ICB is again analyzed following the ICV; all element responses must be less than the laboratory's established MDL_{sp} for MDLs determined via Section 4.1.3.1 or the portion of the MDL represented by $s \cdot K$ for MDLs determined via Section 4.1.3.2. If the ICB does not meet this criterion, the analysis sequence must be stopped and the source of the contamination found before analysis may continue.

4.4.11.7.4 Interference Check Standard. Once the instrument has been calibrated, the calibration verified by analysis of the ICV, and the system shown to be free of contaminants by analysis of the ICB, the instrument must be shown to be free of interferences by analysis of an interference check standard (ICS). The ICS must be analyzed immediately following the ICB, every 8 hours of continuous operation, and at the conclusion of the analysis sequence just prior to the final CCV.

Analysis of the ICS allows for the explicit demonstration that known isobaric and/or polyatomic interferences do not impact concentration results. Two types of ICS should be analyzed. A Type A ICS contains elements known to form interferences, and a Type B ICS consists of a standard solution of target elements subject to interferences from elements in ICS Type A. ICS Type A solutions should contain high levels of elements such as Al, Ca, Cl, Fe, Mg, Mo, P, K, Na, S, and Ti at 20 to 20,000 mg/L which are known interferences to target elements such as As, Cd, Cr, Co, Cu, Mn, Ni, and Se. These target elements should be present in ICS Type B solutions at concentrations of approximately 10 to 20 mg/L, or lower concentrations, as appropriate, anticipated to interfere with the analysis.

Analysis of ICS Type A must demonstrate that concentrations of all target analytes are less than $3x MDL_{sp}$ (for MDLs determined by Section 4.1.3.1) or three-fold the portion of the MDL represented by $s \cdot K$ for MDLs determined via Section 4.1.3.2. Note that ICS Type A solutions typically contain target analytes at quantifiable concentrations. ICS certificates of analysis should be examined to determine whether observed concentrations above this criterion are due to contaminant levels in the ICS Type A solution. Background subtraction of these levels may be necessary if observed concentrations exceed the acceptance criterion. The ICS Type B solution must show recovery of target elements of 80 to 120%. Concentrations of target elements in samples which exceed the concentrations in ICS Type B solutions should be diluted and reanalyzed.

ICP/MS equipped with reaction collision cells are less susceptible to isobaric and polyatomic interferences than those without and may demonstrate little to no measureable interferences when analyzing Type A ICS solutions. However, to ensure the collision reaction cell is operating properly, the ICS Type A and Type B solutions must be analyzed minimally once each day of analysis to ensure proper operation of the cell.

4.4.11.7.5 Continuing Calibration Verification. At a minimum, a CCV must be prepared at a single concentration at approximately the mid-range of the calibration curve, must

be diluted from the primary stock or secondary source stock solution, and must be analyzed following the ICS, prior to the analysis of samples, after the analysis of every 10 digestates, and at the end of the analytical sequence. CCV recovery must be 90 to 110% for each target element. As a best practice, two or more concentrations of CCV may be prepared and analyzed so as to better cover instrument performance across the range of the calibration curve.

4.4.11.7.6 Continuing Calibration Blank. The CCB is from the same solution as the ICB and must be analyzed after each CCV to ensure the instrument background remains acceptably low. A CCB is not required after the CCV concluding the analysis sequence. CCB analysis must show that the absolute value of the instrument concentration response for each target element is less than the laboratory's established MDL_{sp} for MDLs determined via Section 4.1.3.1 or the portion of the MDL represented by $s \cdot K$ for MDLs determined via Section 4.1.3.2. If the CCB does not meet this criterion, the analysis sequence must be stopped and the source of the contamination found before analysis may continue. Samples analyzed since the last acceptable CCB require reanalysis.

4.4.11.7.7 Laboratory Digestion Batch Quality Control Samples. Laboratory digestion batch QC samples for low volume Teflon[®] and high volume QFF media described in Sections 4.4.9.5 and 4.4.10.5, respectively, are analyzed with each analysis batch. Laboratory QC samples (consisting of RBs, MBs, RBSs, and LCSs) are analyzed after the first CCV and CCB pair and should be analyzed prior to the analysis of field samples in the same digestion batch. Duplicate digested samples, matrix spikes, and matrix spike duplicates similarly should be analyzed immediately following their parent field sample. In order to minimize reanalysis if more than one digestion batch is included in an analysis batch, each digestion batch should be analyzed altogether and separated by a CCV and CCB prior to analysis of the next digestion batch.

4.4.11.7.8 Serial Dilution. A sample must be chosen for each analysis batch for serial dilution. A sample digestate should be diluted five-fold and fortified with IS (so that the concentration of the IS is the same as in the parent sample). Element concentrations for elements $\geq 5x$ MDL in the serially diluted sample must recover within 90 to 110% of the undiluted sample.

4.4.11.7.9 Replicate Analysis. A replicate of digestate from a field-collected sample must be analyzed at the minimum rate of one for every 20 field-collected samples in the analysis batch. Precision of the replicate analysis must be $\leq 10\%$ RPD for elements $\geq 5x$ MDL.

4.4.11.8 ICP/MS Data Review and Concentration Calculations. The concentration for each field-collected sample must be reported in ng/m³ in local conditions. Results may additionally be reported by correction to standard atmospheric conditions of 25°C and 760 mm Hg. Conversion of collected volume in local conditions to standard conditions is performed as follows:

$$Q_s = \frac{P_a \cdot Q_a \cdot T_s}{P_s}$$

where:

- Q_s = flow at standard conditions (760 mmHg and 25°C)
- P_s = standard barometric pressure = 760 mmHg
- T_s = standard temperature in K = 298.15K
- Q_a = flow at ambient conditions
- P_a = ambient barometric pressure in mmHg
- T_a = ambient temperature in K

Results must not be corrected for calibration blank or MB levels. Concentrations exceeding acceptance criteria for these blanks must prompt investigation as to the source of contamination.

Concentration results which exceed the instrument calibration range must be diluted and analyzed within the calibration range. The diluted result must be reported and the associated MDL adjusted accordingly by the dilution factor. For example, if the sample is diluted by a factor of two to analyze nickel within the calibration curve, the MDL should be increased by a factor of two when reporting to AQS.

Negative concentration results which exceed the absolute value of the laboratory's established MDL_{sp} for MDLs determined via Section 4.1.3.1, or the portion of the MDL represented by $s \cdot K$ for MDLs determined via Section 4.1.3.2. MDL_{sp} for field-collected samples indicate the likely existence of contamination problems in the reagents, standards, or labware used to prepare the calibration curve. Negative concentrations should not be qualified as "9" when entered in AQS as this qualifier indicates that negative concentrations were replaced with zero. Overly negative concentrations are further discussed in Section 6.6.1.

4.4.11.8.1 Concentration Calculations for Low Volume Sampling. To calculate the airborne concentration of each element measured on the Teflon[®] filter, the ICP/MS measured concentration in $\mu\text{g/mL}$ is multiplied by the sample digestate final volume in mL and by the dilution factor (if dilution of the digestate was performed), and is divided by the sampled air volume in m^3 , as follows:

$$C_{\text{air}} = \frac{C_{\text{ICP/MS}} \cdot V_{\text{dig}} \cdot D}{1000 \cdot V_{\text{air}}}$$

where:

- C_{air} = Concentration of the element in air at local conditions (ng/m^3)
- $C_{\text{ICP/MS}}$ = Concentration measured in the sample digestate ($\mu\text{g}/\text{mL}$)
- V_{dig} = Volume of digestate (mL)
- DF = Dilution factor
- V_{air} = Volume of air sampled (m^3)

4.4.11.8.2 Reporting of Concentrations for High Volume Sampling. To calculate the airborne concentration of each element measured on the QFF, the ICP/MS measured concentration in $\mu\text{g}/\text{mL}$ is multiplied by the final digestate volume in mL, by the fraction of the

filter digested for analysis, and by the dilution factor (if dilution of the digestate was performed), then is divided by the sampled air volume in m³, as follows:

$$C_{\text{air}} = \frac{C_{\text{ICP/MS}} \cdot V_{\text{dig}} \cdot D \cdot F_f}{1000 \cdot V_{\text{air}}}$$

where:

C_{air}	=	Concentration of the element in air at local conditions (ng/m ³)
$C_{\text{ICP/MS}}$	=	Concentration measured in the sample digestate (µg/mL)
V_{dig}	=	Volume of digestate (mL)
DF	=	Dilution factor
F_f	=	Fraction of exposed filter digested ^a
V_{air}	=	Volume of air sampled (m ³)

^a For a 1 inch × 8 inch strip portioned as described in Section 4.4.11.5.2, this is equivalent to 1/9 by dividing the exposed area of the portioned strip by the area of the exposed filter.

$$(1 \text{ inch} \times 7 \text{ inch} = 7 \text{ in.}^2) / (7 \text{ inch} \times 9 \text{ inch} = 63 \text{ in.}^2) = 1/9$$

4.4.12 Summary of Method Quality Control Requirements. QC requirements are summarized in Table 4.4-3.

Table 4.4-3. Method Criteria Parameters for NATTS Metals Analysis

Parameter	Description and Details	Required Frequency	Acceptance Criteria
ICP/MS Tuning	ICP/MS mass calibration and resolution checks	Analysis of a minimum of five aliquots of the tuning solution each day of analysis prior to ICAL	Absolute signal of five replicates RSD \leq 5% Mass calibration within 0.1 amu of unit mass Resolution check within 0.75 amu at 5% peak height Alternatively, must meet manufacturer tuning criteria
Internal Standards Addition	Elements other than target elements used to monitor instrument performance and correct for matrix effects	Added to each analyzed solution	Recovery within 60-125% of the response of the initial calibration blank
Rinse Blank	2% (v/v) HNO ₃ aspirated to eliminate memory effects between solutions	Following each analyzed solution	Duration of aspiration sufficient to eliminate element carryover as evidenced by successful CCVs and CCBs
Initial Calibration (ICAL)	Minimum of three levels covering the desired concentration range plus the calibration blank	Each day analysis is performed	Correlation coefficient (r) \geq 0.995
Initial Calibration Verification (ICV)	Second source calibration verification (SSCV) or QC standard analyzed to verify the ICAL	Each day of analysis immediately following the ICAL	Recovery within 90-110% of nominal for all target elements
Initial Calibration Blank (ICB)	Calibration blank analyzed to ensure instrument is sufficiently clean to continue analysis	Each day of analysis immediately following the ICV	All target elements $<$ MDL _{sp} (refer to Section 4.1.3.1) or $s \cdot K$ (refer to Section 4.1.3.2)
Interference Check Standard (ICS) A	Solution containing known interferences analyzed to demonstrate that the effect of such interferences is sufficiently low	Following the ICB, after every 8 hours of analysis, and just prior to the concluding CCV Once daily for ICP-MS equipped with collision reaction cell	All target elements $<$ MDL _{sp} (refer to Section 4.1.3.1) or $s \cdot K$ (refer to Section 4.1.3.2) – may be subtracted for ICS A certificate of analysis
Interference Check Standard (ICS) B	Solution containing target elements at high concentrations to demonstrate acceptable recovery	Following the ICB, after every 8 hours of analysis, and immediately preceding ICS A Once daily for ICP-MS equipped with collision reaction cell	Recovery within 80-120% of nominal for all target elements
Continuing Calibration Verification (CCV)	Calibration or second source standard analyzed to verify instrument remains in calibration	Immediately following the initial ICS, after every 10 samples and at the conclusion of the analysis sequence	Recovery within 90-110% of nominal for all target elements

Table 4.4-3. Method Criteria Parameters for NATTS Metals Analysis (Continued)

Parameter	Description and Details	Required Frequency	Acceptance Criteria
Continuing Calibration Blank (CCB)	Analysis of the calibration blank solution to ensure instrument is sufficiently clean to continue analysis	After each CCV except at the conclusion of the analysis sequence	All target elements < MDL _{sp} (refer to Section 4.1.3.1) or $s \cdot K$ (refer to Section 4.1.3.2)
Reagent Blank (RB)	Aliquot of digestion solution taken through the digestion process	One per digestion batch of 20 or fewer field-collected samples	All target elements < MDL _{sp} (refer to Section 4.1.3.1) or $s \cdot K$ (refer to Section 4.1.3.2)
Method Blank (MB)	Blank filter or filter strip taken through the digestion process	One per digestion batch of 20 or fewer field-collected samples	All target elements < MDL
Reagent Blank Spike (RBS)	Aliquot of digestion solution spiked with known amount of target elements and taken through the digestion process	One per digestion batch of 20 or fewer field-collected samples	Recovery within 80-120% of nominal for all target elements
Laboratory Control Sample (LCS)	Filter or filter strip spiked with a known amount of each target element and taken through the digestion process	One per digestion batch of 20 or fewer field-collected samples	Recovery within 80-120% of nominal for all target elements, Sb recovery 75-125%.
Laboratory Control Sample Duplicate (LCSD)	Duplicate filter or filter strip spiked with a known amount of each target element and taken through the digestion process	(Optional) One per digestion batch of 20 or fewer field-collected samples	Recovery within 80-120% of nominal for all target elements, Sb recovery 75-125%, precision \leq 20% RPD of LCS
Duplicate Sample Strip	Additional strip from a field-collected filter taken through the digestion process	*QFF only* One per digestion batch of 20 or fewer field-collected samples	Precision \leq 20% RPD for elements \geq 5x MDL
Matrix Spike	Strip from a field-collected filter spiked with a known amount of each target element and taken through the digestion process	*QFF only* Once per analysis batch of 20 or fewer samples	Recovery within 80-120% of the nominal spiked amount for all target elements, Sb recovery 75-125%.
Matrix Spike Duplicate	Additional strip from the same field-collected filter as the MS, and spiked with the same amount of each target element as the MS, and taken through the digestion process	*QFF only* One per digestion batch of 20 or fewer field-collected samples	Recovery within 80-120% of the nominal spiked amount for all target elements, Sb recovery 75-125%, precision \leq 20% RPD of MS
Collocated Sample	Sample collected from a separate sampling unit concurrently with the primary sample	10% of primary samples for sites conducting collocated sampling (as required by workplan)	Precision \leq 20% RPD of primary sample for elements \geq 5x MDL
Serial Dilution	Five-fold dilution of a sample digestate to assess matrix effects	One per digestion batch of 20 or fewer field-collected samples	Recovery within 90-110% of undiluted sample for elements \geq 25x MDL
Replicate Analysis	Second aliquot of a sample digestate chosen for replicate analysis	One per digestion batch of 20 or fewer field-collected samples	Precision \leq 20% RPD for elements \geq 5x MDL

4.4.13 References

1. Determination of Metals in Ambient Particulate Matter Using Inductively Coupled Plasma/Mass Spectrometry (ICP/MS); EPA Compendium Method IO-3.5; *Compendium of Methods for the Determination of Inorganic Compounds in Ambient Air*; EPA/625/R-96/010a; U.S. Environmental Protection Agency: Center for Environmental Research Information. Office of Research and Development. Cincinnati, OH. June 1999. Available at (accessed October 19, 2016):
<https://www3.epa.gov/ttnamti1/files/ambient/inorganic/mthd-3-5.pdf>
2. Care and Safe Handling of Laboratory Glassware. Corning Incorporated. RG-CI-101-REV2. 2011. Available at (accessed October 19, 2016):
http://csmedia2.corning.com/LifeSciences/media/pdf/Care_and_Safe_Handling_Lab_Glassware_RG-CI-101Rev2.pdf
3. Sampling of Ambient Air for PM10 Concentration using the Rupprecht and Pataschnick (R&P) Low Volume Partisol® Sampler; EPA Compendium Method IO-2.3; *Compendium of Methods for the Determination of Inorganic Compounds in Ambient Air*; EPA/625/R-96/010a; U.S. Environmental Protection Agency: Center for Environmental Research Information. Office of Research and Development. Cincinnati, OH. June 1999. Available at (accessed October 19, 2016):
<https://www3.epa.gov/ttnamti1/files/ambient/inorganic/mthd-2-3.pdf>
4. Section, Preparation, and Extraction of Filter Material; EPA Compendium Method IO-3.1; *Compendium of Methods for the Determination of Inorganic Compounds in Ambient Air*; EPA/625/R-96/010a; U.S. Environmental Protection Agency: Center for Environmental Research Information. Office of Research and Development. Cincinnati, OH. June 1999. Available at (accessed October 19, 2016):
<https://www3.epa.gov/ttn/amtic/files/ambient/inorganic/mthd-3-1.pdf>

4.5 Collection and Analysis of PAHs via EPA Compendium Method TO-13A

Each agency must codify in an appropriate quality systems document, such as an SOP, or equivalent, its procedures for performing PAHs sampling, media extraction, and extract analysis. Various requirements and best practices for such are given in this section. Note that regardless of the specific procedures adopted, method performance specifications as given in Section 4.5.6 must be met.

4.5.1 Summary of Method. PAHs, which are semivolatile organic compounds (SVOCs), are collected per the guidance given in EPA Method TO-13A¹ and ASTM D6209.² These two methods are similar and share collection media specifications: utilizing a quartz fiber particulate filter and glass thimble containing PUF and styrene-divinylbenzene polymer resin sorbent (XAD-2 or equivalent) to collect PAHs from ambient air.

Approximately 200 to 350 m³ of ambient air is drawn through a quartz fiber particulate filter and cartridge containing a “sandwich” of PUF-resin-PUF over 24 hours. The QFF and contents of the cartridge are extracted by way of accelerated solvent extraction (ASE)³ or in a Soxhlet apparatus, and the extract is analyzed by GC/MS. Concentrations of PAHs in ambient air are generally low (0.02 to 160 ng/m³), thus a large volume of air must be collected to ensure sufficient mass is present for quantification with a typical quadrupole MS in SIM mode.

The more volatile PAHs, such as naphthalene, are subject to potential loss from the cartridges due to, for example, volatilization and decomposition from exposure to light.^{4,5} Thus, PAH cartridges should be collected from the sampling unit, protected from light, and brought to ≤ 4°C as soon as possible after the end of the sampling period. Shipment and storage at refrigerated temperatures will further minimize evaporative losses of the more volatile PAHs. PAHs with higher volatility may also be lost from the sorbent cartridge during sampling due to migration out of the cartridge outlet (breakthrough) or from volatilization from the QFF, especially during warm weather.^{6,7}

The PAHs including, but not limited to, those in Table 4.5-1 may be determined by this method.

4.5.2 Sample Collection Equipment. A high volume PS-1 style sampler, or equivalent, which is able to maintain a minimum flow rate of 140 L/min over a 24-hour sampling period is required. Such sampling units are commercially available with various conveniences. The most basic units are equipped with an event timer and an elapsed time counter to control and indicate duration of sample collection. Flow rate is controlled by the fan motor speed, ball valve, or combination. A manometer (such as a magnehelic) is attached to the ports on a venturi located between the sampling inlet and the fan motor to indicate the pressure differential which correlates to the flow rate. Computer control is available on more expensive systems; such units have an automatic start/stop timer, indicate elapsed sampling time, monitor and record flow rates over the course of the collection event, indicate start and stop times, and monitor the pressure differential and adjust the blower speed to ensure a user defined flow setpoint is maintained.

Each high volume sampler should have an extension tube for the motor exhaust to ensure that the sampled atmosphere is not resampled. If so equipped, the exhaust tube must terminate in the

predominant downwind direction minimally 3 meters away from the unit. Care should be taken to ensure that the exhaust does not interfere with other sampling units at the site. The sampling unit inlet must minimally be 2 meters from all other sampling inlets. Sampler siting requirements are listed in Section 2.4.

Table 4.5-1. PAHs and Associated Chemical Abstract Numbers (CAS)

Target Compound	CAS Number
Acenaphthene ^b	83-32-9
Acenaphthylene	208-96-8
Anthracene ^b	120-12-7
Benzo(a)anthracene	56-55-3
Benzo(a)pyrene ^{a b}	50-32-8
Benzo(e)pyrene	192-97-2
Dibenzo(g,h,i)perylene	191-24-2
Benzo(b)fluoranthene	205-99-2
Benzo(k)fluoranthene	207-08-9
Chrysene	218-01-9
Coronene	191-07-1
Dibenzo(a,h)anthracene	53-70-3
Fluoranthene ^b	206-44-0
Fluorene ^b	86-73-7
9-Fluorene	486-25-9
Indeno(1,2,3-cd)pyrene	193-39-5
Naphthalene ^{a b}	91-20-3
Perylene	198-55-0
Phenanthrene ^b	85-01-8
Pyrene ^b	129-00-0
Retene	483-65-8

^a NATTS Tier I core analyte

^b NATTS PT target analyte

4.5.2.1 Sampler Flow Calibration and Verification. Sampler flow must be calibrated initially and when flow verification checks indicate flows deviate by more than 10% from the flow transfer standard flow or design flow. Flow verification checks must be performed quarterly, and are recommended to be performed monthly. Flow verifications must be performed at approximately the setting utilized to collect field samples.

Flow calibration of a non-mass flow controlled sampler (those without computer control) must be performed with a traceable, calibrated flow transfer standard capable of inducing various backpressures to generate different sampling unit flow rates that bracket the target flow rate. Such may be accomplished with an electronic flow meter, a variable orifice, or a series of fixed plate orifices, or similar. The known inlet flows must then be correlated to the measured manometer readings at the flow venturi. Computer controlled units must be electronically adjusted so the flow settings correlate to the calibrated flow rate as indicated by the flow transfer standard.

4.5.2.2 Sampling Unit Maintenance. Each site must have a defined maintenance schedule for the PAHs sampling units, recommended to be monthly, but may not exceed quarterly. Included in this maintenance must be the schedule for the periodic cleaning of the sampling

heads. Sampling heads should be washed with chromatographic grade hexane, acetone, or other suitable solvent to ensure subsequent samples are not contaminated. Use of such solvents should be performed with proper ventilation (e.g. fume hood) and with proper personal protective equipment (PPE – such as solvent impermeable gloves, lab coat, and safety glasses). Other maintenance items should include: inspection of sampling unit electrical connections, check of timers for proper operation, replacement of motors and motor brushes, removal of debris from underneath the gable and inside the upper portion of the sampling unit, and inspection of sealing gaskets.

4.5.3 Sampling Media and Their Preparation. Regardless of the source of materials or the specific cleaning procedures each agency adopts, the QFF and PUF/XAD-2/PUF present in cartridges must meet the batch blank acceptance criteria of < 10 ng each for all target compounds. A batch blank is a complete cartridge (including a QFF) selected from among those purchased in a single lot or from among each batch of cartridges prepared with a specific batch of cleaned media. Note that media components may be analyzed separately, but must meet the cleanliness criterion.

Particulate filters for sample collection are quartz fiber, 102 to 104 mm diameter with 2- μ m pore size. All filters must be inspected on a light table or similar for pinholes, discolorations, tears, or other defects such as thin spots; air samples must not be collected with those found to be unsuitable. After inspection, filters should be baked (in a muffle furnace) at 400°C for a minimum of 4 hours to remove potential impurities and interferences. Once cooled, the filters should be stored in a sealed container to ensure they do not become contaminated prior to sample collection.

PUF plugs are available commercially, or they may be prepared by cutting plugs of the proper diameter (2 3/8 inch) from PUF sheets of 1.5-inch thickness. PUF plugs may be purchased raw and cleaned by the laboratory prior to use, or may be purchased precleaned. Some precleaned PUF plugs do not meet cleanliness criteria for target analytes or may contain interferences which require subsequent cleaning procedures prior to use for sample collection. Precleaned PUF plugs are typically shipped with a certificate of analysis listing the contaminant levels for common PAHs. Following sample extraction, used PUF plugs may be cleaned for reuse, if so desired.

Styrene-divinylbenzene polymer resin, such as XAD-2, is commercially available and may be purchased with or without precleaning. As with precleaned PUF, some precleaned resins do not meet cleanliness criteria for target analytes or may contain interferences which require subsequent cleaning procedures before use for sample collection. Precleaned resin sorbent is generally shipped with a certificate of analysis listing the contaminant levels for common PAHs. Following sample extraction, used resin may be cleaned for reuse. The resin physically degrades and disintegrates over time, requiring periodic replacement.

PUF and/or resin sorbents should be cleaned before reuse with a specialized solvent extraction program that is slightly different than the method by which the QFF, PUF, and resin from a sample cartridge are extracted. A more aggressive solvent or combination of solvents such as methylene chloride (not suitable for PUF cleaning), toluene, hexane, and/or acetone should be

employed to remove target analytes and interferences from the PUF and resin media for cleaning.

All clean media should be stored in sealed containers protected from light (aluminum foil, amber glass, etc.).

4.5.3.1 Glassware Cleaning. Glass thimbles, extraction glassware, and volumetric glassware for preparing standard solutions must be thoroughly cleaned and contaminant-free prior to use such that blank criteria are met as given in Section 4.5.6. Aggressive washing with hot water and laboratory grade soap, tap water rinsing, deionized water rinsing, acid or base rinsing, and solvent (methylene chloride) rinsing may be necessary to ensure that contaminants and interferences are removed from labware prior to use. Non-volumetric glassware may be baked at 400°C for 4 hours. Volumetric glassware must not be heated above 80 to 90°C unless otherwise indicated by the manufacturer as such heating voids the volumetric certification.⁸ Following the final solvent rinse, clean labware should be capped or covered (as appropriate) with solvent rinsed foil to prevent contamination with dust, etc.

4.5.3.2 Cartridge Preparation. If cartridges are assembled in house, they must be assembled in batches, and the lots of media contained in the cartridges must be traceable so as to maintain the ability to track potential contamination. One assembled cartridge from each batch of 20 or fewer assembled cartridges must be extracted as a batch blank. The batch blank ensures the cleaned media and preparation results in acceptably low background levels of target PAHs.

The following procedure should be followed to prepare cartridges. Tools contacting sampling media are solvent rinsed and technicians must wear gloves during cartridge preparation. One 1.5-inch thick PUF plug is placed into the inlet of the cartridge and pushed down to contact the support screen. Note that glass thimble cartridges equipped with a glass frit support are not suitable for NATTS sample collection. The glass frit creates an excessive flow restriction resulting in pre-mature wear and failure of motors and brushes. A 15-gram aliquot of clean resin is then added to the cartridge on top of the PUF plug and distributed evenly. The second 1.5-inch thick PUF plug is then placed on top of the resin layer to retain the resin layer in place.

For storage, cartridges should be wrapped in solvent rinsed foil, sealed in a resealable plastic bag or other container, and kept at $\leq 4^{\circ}\text{C}$.

4.5.3.3 Field Surrogate Addition. Prior to dispatching sample cartridges to the field, field surrogate compounds must be added to the sorbent media. The recovery of field surrogate compounds is evaluated to assess the retention of PAHs during air sampling as well as the performance of the sample media handling, extraction, and analysis procedures.

Field surrogates should be added by spiking 1 μg (e.g., 100 μL of a 10 $\mu\text{g}/\text{mL}$ solution in methylene chloride, toluene, hexane, or other suitable solvent) of, for example, fluoranthene- d_{10} and benzo(a)pyrene- d_{12} directly into the PUF and resin sorbent. Field surrogates are added no sooner than two weeks prior to the scheduled sample collection date.

4.5.4 PAH Sampling. Sample media must be installed into the sampling unit as close to the sampling date as possible to minimize positive bias due to passive sampling of the sorbent media. At the time of installation, sampling units without computerized flow control must be allowed to warm up for minimally five ten minutes (ten minutes are recommended) prior to recording the initial flow rate, i.e., the manometer reading. Computer-controlled sampling instruments do not require this warm-up period to record the initial flow. The ambient barometric pressure and temperature must be measured with calibrated instruments and recorded.

The QFF and cartridge are loaded into a sampling head. At the head's outlet is a cam-lock connection which connects the head to the PS-1 sampling unit, and at the head inlet is a threaded ring filter holder to accept the QFF. The head may be unscrewed in the middle such that the glass cartridge may be inserted inside into a cartridge body. Inert gaskets (such as silicone rubber) are placed in the top and bottom of the cartridge body inside the sampling head. A filter is placed onto the support screen of the filter holder, and an inert gasket (such as polytetrafluoroethylene [PTFE]) seals the filter to the top filter retaining ring. The filter is protected during handling by a cover secured to the filter holder with three swing bolts.

4.5.4.1a Sampling Schedule and Duration. PAHs sample collection must be performed on a 1-in-6 days schedule for 24 ± 1 hours beginning at midnight and concluding on midnight of the following day, local time unadjusted for daylight savings time, per the national sampling calendar. For missed or invalidated samples, a make-up sample should be scheduled and collected per Section 2.1.2.1. Clock timers controlling sampling unit operation must be adjusted so that digital timers are within ± 5 minutes of the reference time (cellular phone, GPS, or similar accurate clock) and mechanical timers within ± 15 minutes.

4.5.4.1b Retrieval, Storage, and Transport of QFFs and Cartridges. The QFF and glass cartridge must be retrieved as soon as possible after the conclusion of sampling in order to minimize the evaporative loss of the more volatile PAHs, preferably within 24 hours, but not to exceed 72 hours of the end of collection. Such is particularly important during warm weather. As with sample setup, units without computerized flow control must be allowed to warm up for minimally five minutes (ten minutes are recommended) prior to recording the manometer reading, which is recorded as the ending flow setting. Computer-controlled sampling units do not require this warm-up period. The ambient barometric pressure and temperature must be measured with calibrated instruments and recorded.

To retrieve a sample, the following procedure should be followed. It is recommended that the operator dons non-latex powder-free gloves to place the filter cover onto the filter inlet and secure the cover with the swing bolts. The operator then releases the cam-locks, disconnects the sampling head from the sampling unit, and covers the outlet end of the sampling head with foil or suitable plug. The assembled sampling head is transported to a clean indoor environment, free of obvious PAHs sources, for disassembly. If the disassembly is to occur more than 10 minutes following sample retrieval, the sampling head is stored and transported refrigerated.

For sampling head disassembly, gloves must be donned, the filter cover removed, and the filter carefully retrieved and folded into fourths with the particulate matter inward. The folded filter is then inserted into the glass thimble cartridge with the sorbent media. It is not acceptable to place

the folded filter into a secondary container such as a petri dish, as jostling of the filter inside the petri dish may result in loss of PM to the inside of the dish. Storage inside the glass cartridge minimizes disturbance of PM to ensure that PM is either on the filter or within the PUF inside the glass thimble. The glass thimble cartridge is removed from the sampling head, wrapped in solvent-rinsed foil, and placed within a protective jar or case for shipment.

The protective jar or case containing the cartridge must be stored at $\leq 4^{\circ}\text{C}$ until shipment to the laboratory. The sample should be kept cold during shipment such that the temperature remains $\leq 4^{\circ}\text{C}$, and the temperature of the shipment must be determined upon receipt at the laboratory. For transport of samples which are retrieved at a site and delivered to the laboratory on the day of retrieval, it may be difficult to sufficiently cool samples to $\leq 4^{\circ}\text{C}$ by the time they are received at the laboratory. It is imperative that samples be placed into cold storage for transport as soon as possible after retrieval, so samples arrive at the laboratory chilled. Samples which are shipped overnight should be packed with sufficient cold packs or ice to ensure they arrive at the laboratory at $\leq 4^{\circ}\text{C}$. The sample custody form must be completed and accompany the collected sample at all times until relinquished to the laboratory. COC documentation must comply with Section 3.3.1.3.7. If cartridges are broken, resin has escaped, or the sampling media otherwise compromised, the sample must be voided.

4.5.4.2 Field Blanks. Field blanks must be collected minimally monthly. A field blank is a complete blank cartridge and QFF fortified with field surrogates and assembled in a sampling head identically to a field-collected sample except that there is no sample flow. To collect a field blank, the assembled sampling head is minimally installed into the sampling unit and the filter cover removed for minimally 5 minutes. The field blank is then retrieved as a regularly collected field sample and placed into cold storage until the co-collected field sample is transported/shipped to the laboratory for analysis.

Field blanks must show that all target PAHs are $\leq 5x$ MDL. Results for field collected samples associated with the failing field blank and collected since the last acceptable field blank must be appropriately qualified when entered into AQS.

An exposure blank is similar to a field blank, but is not required, and may be collected via several protocols. The exposure blank includes exposing the filter and sorbent media to the ambient conditions by installation in a sampling unit, and just like a field blank, air is not drawn through the exposure blank sampling head. The exposure blank sample may be installed in the primary sampling unit on non-sample collection days or may be installed in a collocated sampling unit during collection of the primary sample.

4.5.4.3 Collocated Sampling. Collocated samples must be collected at a frequency of 10% of the primary samples for sites conducting collocated sampling (as required by the workplan). A collocated sample is a second assembled sampling head (cartridge and QFF) collected via a separate PAHs sampling unit. The collocated sampling unit inlet must be between 2 to 4 meters from the primary sampling inlet.

Collocated samples must demonstrate precision $\leq 20\%$ RPD for instrument measured concentrations $\geq 0.5 \mu\text{g/mL}$. Root cause analysis must be performed for instances in which

collocated samples fail this precision specification and the results of the primary and collocated samples must be qualified when entered into AQS.

4.5.5 PAH Extraction and Analysis

4.5.5.1 Reagents and Standard Materials

4.5.5.1.1 Solvents. Solvents employed for extraction and preparation of standards solutions must be high-purity chromatographic grade, and shown by analysis to be free of contaminants and interferences. Suitable solvents include dichloromethane, n-hexane, methanol, diethyl ether, and acetone.

4.5.5.1.2 Calibration Stock Materials. Calibration source material must be of known high purity and must be accompanied by a COA. Calibration materials should be neat high purity solids or sourced as certified single component or component mixtures of target compounds in solvent.

Neat solid material must be weighed with a calibrated analytical balance with the appropriate sensitivity for a minimum of three significant figures in the determined standard mass. The calibration of the balance must be verified on the day of use with certified weights bracketing the masses to be weighed. Calibration standards diluted from stock standards should be prepared by delivering stock volumes with mechanical pipettes (preferably positive displacement) or gastight syringes calibrated and the volumes dispensed into Class A volumetric glassware to which solvent is added to establish a known final dilution volume.

4.5.5.1.2.1 Secondary Source Calibration Verification Stock Material

A secondary source standard must be prepared to verify the calibration of the GC/MS on an ongoing basis. This secondary source stock standard must be purchased from a different supplier than the calibration stock. The SSCV stock may only be a different lot from the same supplier if unavailable from another supplier.

4.5.5.1.3 Internal Standards. ISs are required to correct for both short-term variability in GC/MS performance and for potential matrix effects. ISs must be added to all analyzed solutions at the same concentration. IS compounds should be chemically and chromatographically similar to the target compounds.

Deuterated analogs of target compounds are recommended as ISs. Suggested deuterated standards include: naphthalene-d₈, acenaphthene-d₁₀, perylene-d₁₂, phenanthrene-d₁₀, and chrysene-d₁₂. These ISs should be purchased as high purity single or multi-component mixtures in solvent. Note that deuterated standards also contain small amounts of the target compound which may appear as contamination if the concentration of IS added is too high.

4.5.5.1.4 Surrogate Compounds. Surrogate compounds are required to monitor and assess the retention of PAHs on the adsorbent media and the performance of the sample media handling, extraction, and analysis procedures. Two types of surrogate compounds are prescribed

for the subject method, field surrogates and extraction surrogates. As with ISs, deuterated analogs of target compounds are recommended for surrogate compounds.

4.5.5.1.4.1 Field Surrogate Compounds

Field surrogates are required and were previously described in Section 4.5.3.3. Fluoranthene-d₁₀ and benzo(a)pyrene-d₁₂ are the recommended field surrogate compounds. Stock standard solutions of these two surrogate compounds in solvent are commercially available and are diluted to working concentrations in suitable solvent (i.e., hexane).

4.5.5.1.4.2 Extraction Surrogate Compounds

Extraction surrogate compounds must be added to the sample media just prior to extraction and their recoveries are evaluated to assess the performance of the extraction and analysis procedures. Fluorene-d₁₀ and pyrene-d₁₀ are the recommended extraction surrogate compounds and 1 µg should be added to the media (e.g., 10 µL of 10 µg/mL solution). Stock standard solutions of these two surrogate compounds in solvent are commercially available and are diluted to working concentrations in suitable solvent (i.e., hexane).

4.5.5.2 Hold Times and Storage Requirements. Collected samples must be transported and stored at ≤ 4°C until extraction, and must be extracted within 14 days of collection. Extracts must be stored in amber or foil-wrapped vials at ≤ 4°C, however storage in a freezer at ≤ -10°C is preferable. Extracts must be analyzed within 40 days of extraction. Working standards and open ampules of stock standards must be stored protected from light at ≤ -10°C in Teflon sealed amber vials in a storage unit separate from sampled cartridges and sample extracts.

4.5.5.3 Extraction, Concentration, and Cleanup. Extraction of samples may be performed by Soxhlet or ASE; these techniques are described in more detail below.

4.5.5.3.1 Soxhlet Extraction. Each Soxhlet extraction batch must include 20 or fewer field-collected samples and a MB. An LCS, and LCSD are required quarterly, but recommended with each extraction batch. Prior to extraction, each field-collected sample and QC sample must be fortified with extraction surrogate standards (typically fluorene-d₁₀ and pyrene-d₁₀). Extraction should be performed by combining the QFF, PUF plugs, and resin sorbent into the soxhlet extraction vessel and extracting with sufficient 90:10 hexane:diethyl ether to cover the sample media. Extraction should be performed for a minimum of 18 hours and the temperature of heating mantle should be set such that reflux occurs at a rate of at least three cycles per hour.

Extracts must be capped, protected from light, and stored refrigerated at ≤ 4°C if they are not to be concentrated immediately following extraction.

4.5.5.3.2 Accelerated Solvent Extraction. To perform ASE, a 100 mL ASE cell should be packed as follows: QFF, top PUF plug, resin, bottom PUF plug, and clean Ottawa sand to fill the cell. Each extraction batch must include 20 or fewer field-collected samples and an MB. An LCS and LCSD are required quarterly, and recommended with each batch. Prior to

extraction, each field sample and quality control sample must be fortified with extraction surrogate standards (typically fluorene-d₁₀ and pyrene-d₁₀). To ensure the cell seals properly, stray resin grains should be removed from the threads with a horsehair brush or compressed air.

The following procedure should then be followed: install the cells into the extractor, install the clean extract collection bottles, verify that the solvent reservoirs are full, and start the extraction program. A recommended solvent combination for ASE is 2:1 or 3:1 hexane:acetone (v:v).³ An example ASE program follows:

temperature:	60°C
cycles:	minimum of 3
purge:	60 seconds
static time:	5 minutes
flush:	50%

Extracts must be capped, protected from light, and stored refrigerated at $\leq 4^{\circ}\text{C}$ if they are not to be concentrated immediately following extraction.

4.5.5.3.3 Extract Concentration and Cleanup

4.5.5.3.3.1 Extract Concentration

Refrigerated extracts are equilibrated to room temperature prior to concentration. It is recommended that extracts be dried by passage through approximately 10 g of sodium sulfate, where the eluate is collected into a concentration flask or tube. The extraction flask and sodium sulfate are then rinsed three times with extraction solvent and the rinsate collected into the concentration vessel.

Prior to use, sodium sulfate should be solvent rinsed and placed in an oven at 400°C for a minimum of 4 hours to remove impurities. Muffled sodium sulfate should be cooled and stored in a desiccator to minimize contact with humidity in ambient air.

Extracts should be concentrated by either Kuderna-Danish (K-D) or nitrogen blowdown techniques. The extracts must not be allowed to evaporate to dryness.

4.5.5.3.3.1.1 Concentration via Kuderna-Danish

To concentrate via K-D, the following procedure should be followed. Attach a Snyder column to the K-D apparatus and concentrate to approximately 5 mL on a water bath set to 30 to 40°C. Rinse the Snyder column and concentrator flask with several mLs of n-hexane and allow the solvent to drain into the concentrator tube. Concentrate to < 1 mL final volume via nitrogen blow-down or via micro-Snyder column. Bring the extract to 1.0 mL final volume via syringe, rinsing the concentration tube with n-hexane as the extract is drawn into the syringe. Following concentration to 1 mL, the extract is ready for analysis unless further cleanup is required. Extract cleanup is explained in Section 4.5.5.3.3.2.

4.5.5.3.3.1.2 Concentration via Nitrogen Blowdown

Several nitrogen blowdown evaporator concentrator instruments are commercially available. As the release of large volumes of solvent is detrimental to air quality, systems which capture the evaporated solvent are preferable.

The solvent should be concentrated to < 1 mL final volume in a water bath set to 30-40°C and the final volume of the extract should be established as 1.0 mL with a calibrated syringe. The concentration tube should be rinsed with GC-grade n-hexane as the extract is drawn into the syringe.

Following concentration to 1 mL, the extract is ready for analysis unless further cleanup is required. Extract cleanup is explained in Section 4.5.5.3.3.2.

4.5.5.3.3.2 Extract Cleanup

A cleanup step may be required in order to clarify cloudy extracts or remove interfering compounds from extracts showing significant chromatographic interferences.

To clarify cloudy extracts, they are passed through a packed column of 10 g of silica gel as detailed in EPA Compendium Method TO-13A and ASTM D6209. Ambient air matrices typically do not result in cloudy extracts and therefore likely do not require additional cleanup.

4.5.5.4 PAH Method Detection Limits. MDLs for PAHs must be determined minimally annually by following the procedures in Section 4.1. To ensure that the variability of the media and the extraction process is characterized in the MDL procedure, cartridges and QFFs must be extracted (it does not suffice to simply analyze a low-concentration solution of PAHs) and blank and spiked cartridges with QFFs must be prepared. For example, laboratories determining the MDL following Section 4.1.2.1 must prepare and extract a minimum of seven method blank cartridges and QFFs and a minimum of seven spiked cartridges and QFFs over the course of three different dates (preferably non-consecutive). The resulting extracts must be analyzed in three separate analytical batches (three different calendar dates – preferably non-consecutive). All steps performed in the preparation and analysis of field sample cartridges must be included in the MDL procedure.

Note that at very low levels approximating the MDL, the qualitative identification criteria related to qualifier ion abundance ratio and/or signal-to-noise ratio listed in Section 4.5.5.5.7 may not be strictly met when determining the MDL. As the MDL spikes are prepared in a clean matrix with standard materials, the presence of the analyte is expected.

As discussed in Section 4.1.3.1, one MDL spike sample can be added to analysis periodically. Together with the MB from each batch, once results for seven or more MDL spike samples and method blanks are available, the MDL can be calculated.

4.5.5.5 PAH Analysis via GC/MS

4.5.5.5.1 GC/MS Instrumentation. The GC should be capable of temperature programming such that the temperature may be ramped from 25°C to 290°C at a rate of 8°C/minute or faster. A 30 to 50 m by 0.25 mm fused silica capillary column coated with 0.25 µm crosslinked or bonded 5% phenyl methylsilicone film, or equivalent suitable column capable of separating the target analytes, surrogates, and ISs with appropriate resolution, should be installed in the GC. The carrier gas should be helium or hydrogen. Injector and transfer line should be capable of maintaining 275-300°C. GC injection volume should be 1.0 µL.

Electron ionization should be performed at 70 eV and the MS should be operated in SIM mode to maximize sensitivity to ions of the target compounds of interest. Alternatively, for instruments which are capable, operation in combination SIM/scan mode is preferred. Spectrometers operating in full scan mode may lack sufficient sensitivity. If full scan is performed, the MS should be capable of scanning from 35-500 amu in ≤ 1 second.

4.5.5.5.2 Tuning of the MS. The GC/MS must be tuned prior to calibration and every 12 hours of analysis thereafter via analysis of 5 to 50 ng of DFTPP.

If operated in full scan mode or SIM/scan mode, the MS tune must be optimized to achieve the ion abundances below in Table 4.5-2.

For instruments operated in SIM mode, the above ion abundance criteria do not apply. Tuning for SIM instruments is optimized to maximize the signal for DFTPP masses greater than 150 amu. The SIM MS tune must maximize the signal for masses 198, 275, 265, and 442 while maintaining unit resolution between masses 197, 198, and 199 as well as 441, 442, and 443.

Table 4.5-2. DFTPP Key Ions and Abundance Criteria

mass	ion abundance criteria
51	30-60% of mass 198
68	< 2% of mass 69
70	< 2% of mass 69
127	40-60% of mass 198
197	< 1% of mass 198
198	base peak, assigned 100% relative abundance
199	5-9% of mass 198
275	10-30% of mass 198
365	> 1% of mass 198
441	present, but < mass 443
442	> 40% of mass 198
443	17-23% of mass 442

4.5.5.5.3 Calibration of the GC/MS. All solutions to be analyzed, including calibration standards, should be removed from refrigerated storage for sufficient time (typically one hour) to equilibrate to ambient temperature prior to analysis.

Calibration standard solutions must be prepared at minimally five separate concentration levels in hexane covering approximately 0.1 to 2.0 µg/mL and must contain surrogate compounds at concentrations bracketing those expected in the sample extracts.

ICAL must be established initially, when continuing calibration criteria are not met, or when an instrument change (ion source cleaning, column trim or change, etc.) may affect instrument calibration (including alteration of retention times). Calibration is recommended every six weeks.

An SB which is not fortified with IS must be analyzed just prior to calibration to ensure the instrument is sufficiently clean to continue analysis. Analysis of the SB must show all target compounds, IS, and surrogate compounds are not detected.

A known volume of each standard should be transferred to a GC analysis vial and fortified with IS just prior to analysis. Recommended quantitation and secondary ions are listed in Table 5 of method TO-13A. Each compound must be assigned to the IS compound with the nearest retention time.

Following data acquisition for the calibration standards, the relative response factor (RRF) of each surrogate and target compound in each calibration level is determined as follows:

$$\text{RRF} = \frac{A_s \cdot C_{IS}}{A_{IS} \cdot C_s}$$

where:

- A_s = peak area for quantitation ion of the surrogate or target compound
- A_{IS} = peak area for quantitation ion of the assigned internal standard compound
- C_s = concentration of the surrogate or target compound
- C_{IS} = concentration of the assigned internal standard compound

The RSD of the RRFs for each surrogate and target compound must be $\leq 30\%$. Alternatively, a calibration curve may be prepared by linear or quadratic regression. The correlation coefficient for linear or quadratic curves must be ≥ 0.995 for target compounds. Irrespective of the curve fit method selected, the calculated concentration of each calibration level must be within 30% of the nominal concentration when quantitated against the resulting calibration curve. Exclusion of calibration standard levels is not permitted unless justifiable (for example, a known error in standard preparation). Sample analysis must not be performed, and if performed, results must not be reported when calibration acceptance criteria are not met. Rather corrective action, possibly including recalibration, must be taken.

The absolute value of the concentration equivalent to the intercept of the calibration curve (intercept/slope or equivalent) converted to concentration units (by division by the slope or equivalent) must be less than the laboratory MDL. When this specification is not met, the source of contamination or suppression must be corrected and the calibration curve reestablished before sample analysis may commence.

RRTs are calculated for each concentration level of each surrogate and target compound by dividing the surrogate or target RT by the associated IS compound RT. The RRTs of each surrogate or target compound across the ICAL are then averaged to determine the ICAL $\overline{\text{RRT}}$. All RRTs must be within ± 0.06 RRT units of $\overline{\text{RRT}}$.

4.5.5.5.4 Secondary Source Calibration Verification. Following each successful initial calibration, a SSCV must be analyzed to verify the initial calibration. The SSCV is prepared at approximately the mid-range of the calibration curve. Alternatively, two or more concentrations of SSCV may be prepared covering the calibration range. All SSCVs must recover within $\pm 30\%$ of nominal or demonstrate an RRF within $\pm 30\%$ of the average RRF of the calibration curve.

4.5.5.5.5 Continuing Calibration Verification. Once the GC/MS instrument has met tuning and calibration criteria, a CCV must be analyzed every 12 hours of analysis following the 12-hour DFTPP tuning check standard. The CCV must recover within $\pm 30\%$ of nominal or demonstrate RRF within 30% of the mean ICAL RRF for all target PAHs. Corrective action must be taken to address CCV failures, including, but not limited to, preparing and analyzing a new CCV, cleaning or replacing the injector liner, trimming or replacing the column, retuning the MS, or preparing a new initial calibration.

4.5.5.5.6 Analysis of QC Samples and Field Samples. The MS must be tuned and the calibration determined or verified prior to the analysis of field samples. ISs should be added to each extract just prior to analysis. Note that a best practice is not to add IS to the entire 1 mL of extract. An aliquot of the extract should be taken for fortification with ISs to preclude loss of the entire extract in the event of IS spiking errors.

The following QC samples are required with each analysis sequence:

- Solvent method blank (SMB)
- MB
- Replicate extract analysis

Prior to analysis of laboratory QC samples or field-collected samples, a SMB consisting of an aliquot of the batch extraction solvent fortified with IS must be analyzed and demonstrate target compounds are $< \text{MDL}$.

Target PAHs must not be present in MBs at concentrations $> 2x \text{MDL}$. Replicate analysis must demonstrate precision of $\leq 10\%$ RPD for all measured concentrations $> 0.5 \mu\text{g/mL}$.

An LCS/LCSD pair is required quarterly and recommended with each extraction batch to monitor recovery and precision in matrix. Target PAHs in the LCS and LCSD must recover within 60 to 120% of nominal and the LCSD must demonstrate precision of $\leq 20\%$ RPD for all target PAHs.

4.5.5.5.7 Compound Identification. Four criteria must be met in order to positively identify a surrogate compound or target PAH:

1. The signal-to-noise ratio of the target and qualifier ions must be $> 3:1$, preferably $> 5:1$.
2. The target and qualifier ion peaks must be co-maximized (peak apexes within one scan of each other).
3. The RT of the compound must be within the acceptable RT window determined from the ICAL average.
4. The abundance ratio of the qualifier ion response to target ion response for at least one qualifier ion must be within $\pm 15\%$ of the average ratio from the ICAL.

If any of these criteria are not met, the compound may not be positively identified. The only exception to this is when in the opinion of an experienced analyst, the compound is positively identified. The rationale for such an exception must be documented. For examples of the qualitative identification criteria and calculation of S:N, refer to Section 4.2.10.5.3.

4.5.5.5.8 Internal Standards Response. IS response must be monitored for each injection (except for the SB immediately preceding the initial calibration or 12-hour tune check). Area responses of the IS must be 50 to 200% of the area responses in the initial calibration mid-level standard and they must elute within ± 20 seconds (± 0.33 minute) of the mean RT of the initial calibration. Extracts which do not meet these response acceptance criteria should be diluted, and the dilution analyzed to examine for matrix interferences. If the IS still does not meet criteria in the dilution, the MS tune should be evaluated for a degradation or enhancement of sensitivity and corrective action taken to address the failure. Sample results calculated from IS criteria failures must be appropriately qualified when entered into AQS.

4.5.5.5.9 Surrogate Evaluation. Following calibration, each analyzed extract should be evaluated to ensure the recovery of each surrogate compound is within 60 to 120% of the nominal spiked value. Results which fall outside of these limits indicate potential analyte loss or enhancement either through sample collection and handling and/or extraction process and must be qualified appropriately when reported to AQS.

4.5.5.5.10 Data Review and Concentration Calculations. For sampling units without computerized flow control, the beginning and ending flows are averaged to calculate the collected air volume. For computer controlled sampling units, the integrated collected volume is typically available from the data logging system. Sampled air volumes must be in STP, 25°C and 760 mm Hg. Sampling unit flows should be calibrated in flows at standard conditions so conversion from local conditions to standard flows is not necessary. For units which do not have computerized flow control, temperature and barometric pressure at sample setup and take down must be recorded.

Each chromatogram must be closely examined to ensure chromatographic peaks are appropriately resolved and integration does not include peak shoulders or inflections indicative of a coelution.

The concentrations of target PAHs in unknowns are calculated by relating the area response ratio of the target PAH and internal standard in the unknown to the relationship derived in the

calibration curve selected in Section 4.5.5.3. The final air concentration of each target PAH is determined by multiplying the concentration in the extract by the final extract volume and dividing by the collected sample air volume at standard conditions of 25°C and 760 mm Hg:

$$C_A = \frac{1000 \cdot C_t \cdot V_e}{V_A}$$

where:

- C_A = concentration of the target compound in air (ng/m³)
- C_t = concentration of the unknown sample in the extract (µg/mL)
- V_e = final volume of extract (mL)
- V_A = volume of collected air volume at STP (m³)

4.5.6 Summary of Quality Control Parameters. A summary of QC parameters is shown in Table 4.5-3.

Table 4.5-3. Summary of Quality Control Parameters for NATTS PAHs Analysis

Parameter	Description and Details	Required Frequency	Acceptance Criteria
Solvent Blank (SB)	Aliquot of solvent (without IS) analyzed to ensure the GC/MS is free of interferences and of compounds of interest (target PAHs, internal standards, and surrogates)	Prior to each DFTPP tune check	No target compound, IS, or surrogates qualitatively detected
DFTPP Tune Check	5 to 50 ng injection of DFTPP for tuning of MS detector	Prior to initial calibration and every 12 hours of analysis thereafter	Abundance criteria listed in table 4.5-2 must be met
Initial Calibration (ICAL)	Analysis of a minimum of five calibration levels covering approximately 0.1 to 2 µg/mL	Initially, following failed DFTPP tune check, failed CCV, or when changes to the instrument affect calibration response. Recommended every six weeks.	Average RRF ≤ 30% RSD and each calibration level must be within ± 30% of nominal For quadratic or linear regression, $r \geq 0.995$, each calibration level must be within ± 30% of nominal
Secondary Source Calibration Verification (SSCV)	Analysis of a second source standard at the mid-range of the calibration curve to verify curve accuracy	Immediately after each ICAL	Recovery within ± 30% of nominal or RRF within 30% of mean ICAL RRF

**Table 4.5-3. Summary of Quality Control Parameters for NATTS PAHs
Analysis (Continued)**

Parameter	Description and Details	Required Frequency	Acceptance Criteria
Continuing Calibration Verification (CCV)	Analysis of a known standard at the mid-range of the calibration curve to verify ongoing instrument calibration	Following each DFTPP tune check not followed by ICAL and recommended at the conclusion of each sample sequence	Recovery within $\pm 30\%$ of nominal or RRF within 30% of mean ICAL RRF
Cartridge Batch Blank	A cartridge (and QFF) selected for analysis to ensure acceptable background levels in the batch of cartridges	One cartridge for each batch of 20 or fewer prepared cartridges	All target compounds each ≤ 10 ng/cartridge
Field Surrogate Compounds	Deuterated PAHs which assess recovery during sample collection, handling, and analysis	Added to every cartridge prior to field deployment	Recovery 60-120% of nominal spiked amount
Internal Standards (IS)	Deuterated PAHs added to extracts to assess the impact of and correct for variability in instrument response	Added to all calibration standards, QC samples, and field sample extracts except the SB	Area response within 50-200% of the response of the mid-level calibration standard in the ICAL.
Extraction Surrogate Compounds	Deuterated PAHs which assess recovery during sample extraction and analysis	Added to media before extraction	Recovery 60-120% of nominal spiked amount
Solvent Method Blank (SMB)	Aliquot of extraction solvent fortified with IS to ensure extraction solvent is free of interferences and target compounds	One with every extraction batch of 20 or fewer field-collected samples	Target compounds $< MDL$
Method Blank (MB)	Blank cartridge and QFF taken through all extraction and analysis procedures	One with every extraction batch of 20 or fewer field-collected samples	Target analyte amounts $\leq 2x MDL$
Laboratory Control Sample (LCS)	Cartridge spiked with known amount of target analyte	Minimally quarterly. Recommended as one with every extraction batch of 20 or fewer field-collected samples	Recovery 60-120% of nominal spiked amount
Laboratory Control Sample Duplicate (LCSD)	Duplicate cartridge spiked with known amount of target analyte	Minimally quarterly. Recommended as one with every extraction batch of 20 or fewer field-collected samples	Recovery 60-120% of nominal spiked amount and precision $\leq 20\%$ RPD compared to LCS
Replicate Analysis	Replicate analysis of a field sample extract	Once with every analysis sequence	Precision $\leq 10\%$ RPD for concentrations $\geq 0.5 \mu\text{g/mL}$
Field Blank (FB)	Blank cartridge and QFF assembly exposed to ambient atmosphere for minimally five minutes	One per month	Target analyte amounts $\leq 5x MDL$
Collocated Samples	Sample collected concurrently with the primary sample	10% of primary samples for sites conducting collocated sampling (as required by workplan)	Precision $\leq 20\%$ RPD for concentrations $\geq 0.5 \mu\text{g/mL}$
Retention Time (RT)	RT of each target PAH, surrogate compound, and internal standard	All qualitatively identified compounds	Target analytes within ± 0.06 RRT units of mean ICAL RRT Internal standards within ± 0.33 minutes of mean ICAL RT

4.5.7 References

1. Determination of Polycyclic Aromatic Hydrocarbons (PAHs) in Ambient Air Using Gas Chromatography/Mass Spectrometry (GC/MS); EPA Compendium Method TO-13A. In *Compendium of Methods for the Determination of Toxic Organic Compounds in Ambient Air (Second Edition)*; EPA 625/R-96/010b; U.S. Environmental Protection Agency, Center for Environmental Research Information. Office of Research and Development. Cincinnati, OH, January 1999. Available at (accessed October 19, 2016): <https://www3.epa.gov/ttnamti1/files/ambient/airtox/to-13arr.pdf>
2. ASTM D6209-13, Standard Test Method for Determination of Gaseous and Particulate Polycyclic Aromatic Hydrocarbons in Ambient Air (Collection on Sorbent-Backed Filters with Gas Chromatographic/Mass Spectrometric Analysis), ASTM International, West Conshohocken, PA, 2013, www.astm.org.
3. Accelerated Solvent Extraction for Monitoring Persistent Organic Pollutants in Ambient Air. White Paper 71064. Aaron Kettle, Thermo Fisher Scientific, Sunnyvale, CA. 2013.
4. Chuang, J.C.; Hannan, S.W.; Koetz, J. R. *Stability of Polynuclear Aromatic Compounds Collected from Air on Quartz Fiber Filters and XAD-2 Resin*; EPA-600/4-86-029; U.S. Environmental Protection Agency, Environmental Monitoring Systems Laboratory, Methods Development and Analysis Division: Research Triangle Park, NC, September 1986.
5. Feng, Y.; Bidleman, T.F. Influence of Volatility on the Collection of Polynuclear Aromatic Hydrocarbon Vapors with Polyurethane Foam. *Environ. Sci. Technol.* 1984, *18*, 330 -333.
6. Yamasaki, H.; Kuwata, K.; Miyamoto, H. Effects of Ambient Temperature on Aspects of Airborne Polycyclic Aromatic Hydrocarbons. *Environ. Sci. Technol.* 1982, *16*, 89-194.
7. Galasyn, J.F.; Hornig, J.F.; Soderberg, R.H. The Loss of PAH from Quartz Fiber High Volume Filters. *J. Air Pollut. Contr. Assoc.* 1984, *34*, 57-59.
8. Care and Safe Handling of Laboratory Glassware. Corning Incorporated. RG-CI-101-REV2. 2011. Available at (accessed October 19, 2016): http://csmedia2.corning.com/LifeSciences/media/pdf/Care_and_Safe_Handling_Lab_Glassware_RG-CI-101Rev2.pdf

5.0: METEOROLOGICAL MEASUREMENTS

A goal of the NATTS network is to leverage existing monitoring sites (such as those conducting criteria pollutant monitoring, PAMS sites, and NCore sites, etc.) to conduct NATTS Program sample collection. Many of the existing 27 NATTS sites conduct site-specific meteorological measurements.

While such site-specific meteorological measurements such as wind speed, wind direction, solar radiation, precipitation, etc. are highly desirable and complement collected NATTS data, only temperature and barometric pressure measurements are required for NATTS sample collection events. If temperature and barometric pressure measurements are not recorded from calibrated temperature and barometric pressure functions on sampling units themselves, they must be recorded from site-specific calibrated meteorological instruments. If site-specific meteorological monitoring is not performed, each site must acquire the applicable temperature and barometric pressure from the closest off-site meteorological monitoring station (i.e., National Weather Service, local airport, etc.). For sites collecting additional meteorological parameters beyond temperature and barometric pressure, please consult EPA's Quality Assurance Handbook for Air Pollution Measurement Systems, Volume IV Meteorological Measurements for more information, available at (accessed October 19, 2016):

<https://www3.epa.gov/ttnamti1/files/ambient/met/draft-volume-4.pdf>

6.0: DATA HANDLING

6.1 Data Collection

All records must be documented in detail sufficient to reconstruct the activities and transformations to generate reported concentration data. If such records are not available, validity of the data cannot be determined. Such records minimally include observations, laboratory measurements, and photographs as well as instrument calibration records and COAs. Records related to manipulation of data such as through data reduction spreadsheets, peak integrations, hand calculations, or calculations handled by a LIMS must be maintained and must be transparent so the transformations may be verified.

6.2 Data Backup

Electronic data acquired from laboratory instruments, field instruments, databases, and data manipulation software in support of NATTS Program work must be maintained for a minimum of six years following acquisition. As previously discussed, this six-year period is needed to cover two consecutive three-year periods needed to assess trends for the NATTS DQO. In order to maintain electronic records for this duration, it is necessary to prevent data loss and corruption by ensuring data redundancy. Each NATTS agency must prescribe data redundancy policies and procedures, which may be included in the NATTS QAPP, SOP, or similar controlled document.

For data acquisition software systems such as CDSs, ICP-MS control and operation software, and environmental control tracking software systems which are connected via computer network, a best practice is to enable automated nightly backups of data to a separate physical hard drive or server, preferably one at a different physical location. Backing up of data to a separate partition on the same hard drive provides little additional security if the hard drive fails. For software systems which are not networked to a server, a best practice is to manually back up the data after completion of each day's activities to removable media (thumb drive, external hard drive, etc.) for transfer to a networked computer or server.

These daily backups must be protected from inadvertent alteration and compiled on a regular frequency, recommended weekly but not to exceed monthly, to an archival system such as a tape drive, DVD, additional external server, cloud storage, etc. This archival must be access-limited by password and/or other security means to a select few individuals as deemed responsible by cognizant management.

Archived electronic data must remain accessible such that retired computer or software systems must be maintained to access data, or archived data converted such that it remains accessible and legible until the archival period has lapsed.

Once archived, archived data should be reviewed or tested to ensure complete records are maintained and data have not been corrupted. Such a review is recommended every six months, but should not exceed annually.

6.3 Recording of Data

Data generated as in Section 6.1 must be recorded so that it is clear who performed the activity, when the activity was performed, and, if applicable, who documented performance of the activity.

6.3.1 Paper Records. Data entries created on paper records such as field collection forms, COC forms, or laboratory notebooks, must be recorded in legibly in indelible ink and must identify the individual creating the entry. Measurements must clearly indicate appropriate units. Individuals creating paper data records must be identified by way of signature or initials unique to the individual and in such a manner that unambiguous identification is possible. One method by which such may be accomplished is to create a cross-reference for each staff person that shows each staff person's printed name, signature, and initials.

6.3.2 Electronic Data Capture. Electronic data recording systems such as electronic logbooks, LIMS, and instrumental data acquisition software generally require a user to log in with a username and password to utilize the system. Each action (entry, manipulation, instrument operation) recorded by such software systems must be attributable to an individual and the corresponding date and time recorded. If so equipped, audit trails must be enabled on software systems in order to record changes made to electronic records.

6.3.3 Error Correction. Changes to recorded data or data manipulation may be required due to calculation errors, incorrectly recorded measurements, or errors noted during data verification and validation. When records are amended, whether paper or electronic, the original record must remain legible or otherwise intact, and the following information must be recorded: the identity of the individual responsible for making the change, the date the change was made and the rationale for the change. For example, hand-written data records may be corrected by a single line through the entry with the correction, the initials of the responsible individual, the date of correction, and the rationale for change documented in close proximity to the correction or identifiable by annotated footnote. For common corrections such as those for incorrect date, illegible entry, calculation errors, etc., a list of abbreviations may be developed to document change rationale. Any such abbreviations must be defined in a quality systems document such as an SOP, or in the front of a logbook, etc.

6.3.3.1 Manual Integration of Chromatographic Peaks. Automated functions for the integration of chromatographic peaks are included in the chromatography data systems (CDS) that control all GC/MS and HPLC instruments. These integration functions should be configured such that little intervention or correction is needed by the analyst, so as to best ensure that peak integration is as reproducible and introduces as little human error as possible. While these functions ensure consistent integration practices, subtle differences in peak shape, coeluting peaks, and baseline noise may result in inconsistent or incorrect peak integration.

Analysts must be properly trained to review and adjust peak integration performed by CDS automated functions, and specific procedures must be codified into each agency's quality system. All manual changes to automated peak integration must be treated as error corrections. Typical corrections to peak integration may include: adjustment of the baseline, addition or removal of a

vertical drop line, or peak deletion if the requisite compound identification criteria are not met. The identification criteria for the chromatography methods are listed as follows:

VOCs: Section 4.2.10.5.3
Carbonyls: Section 4.3.9.5.6
PAHs: Section 4.5.5.5.7

Manual peak deletion, that is, effectively reporting that the compound was not detected, is not permitted in instances in which the peak specified identification criteria are met.

For each adjustment to chromatographic peak integration (manual integration), the record of the original automated integration must be maintained and it is *strongly recommended* that the adjustment be justified with the documented rationale (signal-to-noise too low, incorrect retention time, incorrectly drawn baseline, etc.), analyst initials, and date.

6.4 Numerical Calculations

Numerous calculations and manipulations are necessary to determine the target analyte concentration of a given field-collected sample or QC sample or to determine evaluate whether data generated during calibration verifications meet acceptance criteria.

6.4.1 Rounding. Rounding of values must be avoided until the final step of a calculation. Rounding during intermediate steps risks the loss of fidelity of the calculation which may lead to significant calculation error.

EPA Region IV SESD has developed guidance for rounding which is adopted into the revision of the Volume II of EPA's QA Handbook. This guidance is included in Appendix C of this TAD.

6.4.2 Calculations Using Significant Digits. Final reported results should be rounded to the correct number of significant digits per the rules below. To the extent feasible, carry the maximum number of digits available through all intermediate calculations and do not round until the final calculated result. Non-significant digits that are carried through calculations may be represented using subscripted numerals. (For example, 2.32₁ has three significant figures, with the final 1 being non-significant and carried through to avoid unnecessarily introducing additional error into the final result.)

6.4.2.1 Addition and Subtraction. The number of significant digits in the final result is determined by the value with the fewest number of digits after the decimal place. For example:

$$\begin{array}{r} \text{A} \quad 5.6 \\ \text{B} \quad 63.71 \\ \text{C} \quad + 9.238 \\ \hline \quad 78.5 \end{array}$$

The final result is limited to one decimal place due to the uncertainty introduced in the tenths place by measurement A.

6.4.2.2 Multiplication and Division. The number of significant digits in the final result is determined by the value with the fewest number of significant digits. For example, acrolein was measured by the GC/MS at a concentration of 2.721 ppb from a canister that was diluted with zero air resulting in a dilution factor of 1.41. The dilution factor is applied to the measured result to calculate the in air concentration:

$$\begin{aligned} 2.721 \text{ ppb} \cdot 1.41 &= 3.837 \text{ ppb} \\ &= 3.84 \text{ ppb} \end{aligned}$$

The final result is limited to three significant digits due to the dilution factor containing three significant digits.

6.4.2.3 Standard Deviation. Standard deviation in a final result must not display digits in a place that the sample average does not have a significant digit. Take, for example, the following average and standard deviation of the form $\bar{x} \pm s$:

$$107.2 \pm 2.3\underline{1} \text{ is reported as } 107.2 \pm 2.3$$

The standard deviation is rounded to the appropriate significant digit of the sample average.

6.4.2.4 Logarithms. For converting a value to its logarithm, retain as many places in the mantissa of the logarithm (to the right of the decimal point in the logarithm) as there are significant figures in the number itself. For example (mantissa underlined):

$$\log_{10} 24.5 = 1.\underline{389}$$

For converting antilogarithms to values, retain as many places in the value as there are digits in the mantissa of the logarithm. For example (mantissa underlined):

$$\text{antilog}(1.\underline{131}) = 13.5$$

6.5 In-house Control Limits

The analysis methods detailed in Section 4 specify acceptance criteria for routine QC samples. These acceptance criteria are the maximum allowable ranges permitted, however, laboratories may find that they rarely or never exceed the acceptance criteria. As each laboratory and the associated analyst, instruments, and processes are unique, development of in-house control limits is recommended to evaluate trends and identify problem situations before exceedances to method acceptance criteria occur.

In-house control limits may be generated to evaluate the bias of quality control samples such as the LCS, CCV, SSCV, and to evaluate precision of LCSD, matrix spike duplicate, etc. Warning

limits and control limits are established following acquisition of sufficient data points, generally more than seven, per the guidance in the subsequent sections. Under no circumstances may data be accepted which exceeds method specified acceptance criteria even if in-house warning or control limits have not been exceeded.

6.5.1 Warning Limits. Warning limits are established as a window of two standard deviations surrounding the mean ($\bar{x} \pm 2s$). Exceedance of the warning limit should prompt monitoring of the parameter for values which remain outside the warning limits. For repeated values exceeding the warning limits, corrective action should be taken to address the trend.

6.5.2 Control Limits. Control limits are established as a window of three standard deviations surrounding the mean ($\bar{x} \pm 3s$). Corrective action is required when control limits are exceeded.

6.6 Negative Values

In general, negative values of small magnitude may be expected from certain analytical platforms in the NATTS program, specifically those which do not apply calibration regressions which are forced through the origin. However, depending on the situation, negative numbers can be problematic and indicative of bias due to faulty sensors, contamination in reagents and labware, improper calibration, or calculation errors.

Negative values must be evaluated to ensure that their magnitude does not significantly impact the resulting measurements.

Minimum values will be updated in AQS to permit the reporting of negative values for NATTS parameters. Negative values for all qualitatively identified analytes must be reported to AQS as-is without censoring or replacing with zero.

6.6.1 Negative Concentrations. For analysis measurements, a negative concentration result generated by a positive instrument response (i.e., positive area count) must be investigated to ensure that the negative concentration is of small magnitude such that the absolute value of the concentration is less than the MDL_{sp} (for MDLs determined via Section 4.1.3.1) or $s \cdot K$ for MDLs determined via Section 4.1.3.2. Where negative concentrations fail this criterion, corrective action must be taken to determine and remediate the source of the bias.

6.6.2 Negative Physical Measurements. For physical measurements such as mass, absolute pressure, and flow, negative values generated by an instrument must be evaluated to ensure they do not adversely impact future measurements.

For example, a VOCs sampling unit pressure transducer reads -0.4 psia upon connection to a canister at hard vacuum. The acceptable canister pressure threshold is 0.5 psia. Since negative absolute pressures are impossible, the -0.4 psia reading is significant, especially when compared to an acceptance criterion of 0.5 psia. Due to the -0.4 psia bias, the pressure in another canister at 0.8 psia would be read 0.4 psia and would incorrectly meet the acceptance criterion for sample collection due to the incorrect calibration of the pressure transducer.

7.0: DATA VALIDATION TABLES

The following tables are a distillation of the general quality control guidance and requirements in Section 3 and of the individual methods described in Section 4. More information on each data validation parameter can be located within the text identified in the reference column. Each parameter is assigned a category of importance. The categories in order of decreasing importance are:

1. Critical – Criteria must be met for reported results to be valid – Samples for which these criteria are not met are invalidated.
2. MQO – Required NATTS Measurement Quality Objective which must be attained – Failure to meet these criteria does not necessarily invalidate data, but may compromise data and result in exclusion from trends analysis.
3. Operational – Failure to meet criteria does not invalidate reported results; the results are compromised and on a case-by-case basis may require qualification – refer to Section 3.3.1.3.15 for the list of AQS qualifiers
4. Practical – Failure to meet criteria does not invalidate reported results; results may be compromised but do not require qualification.

The validation tables in the following sections will be available on AMTIC in Microsoft Excel[®] format so the parameters may be sorted according to importance.

7.1 VOCs via EPA Compendium Method TO-15

Parameter	Description and Required Frequency	Acceptance Criteria	Reference	Category
<i>Field Readiness Checks and Collection Activities</i>				
Canister Cleaning Batch Blank	Minimally one canister selected for analysis from a given batch of clean canisters to ensure acceptable background levels in the batch of cleaned canisters - must represent no more than 10 canisters	Each target VOC's concentration < 3x MDL or 0.2 ppb, whichever is lower	Section 4.2.6.2.4 TO-15 Section 8.4.1.6	Critical
Canister Viability	All canisters	Canister must be used within 30 days from final evacuation	Section 4.2.6.2 TO-15 Section 1.3	Operational
Sampling Unit Clock/Timer Check	Verified with each sample collection event	Clock/timer accurate to ± 5 minute of reference for digital timers, ± 15 minutes for mechanical timers, set to local standard time Sample collection period verified to be midnight to midnight	Section 4.2.5.3 and Table 3.3-1	Operational
Canister Starting Pressure Determination	Each canister prior to collection of a field sample or preparation of a calibration standard or laboratory QC sample	Vacuum > 28" Hg as determined with calibrated pressure gauge or transducer	Section 4.2.5.2.1	Critical
Sample Setup Leak Check	Each canister prior to collection - draw vacuum on canister connection	Leak rate must be < 0.2 psi over 5 minutes	Section 4.2.5.2.1	Critical
Sampling Frequency	One sample every six days according to the EPA National Monitoring Schedule	Sample must be valid or a make-up sample should be scheduled (refer to Section 2.1.2.1)	Section 4.2.5.3	Critical and MQO
Sampling Period	All field-collected samples	1380-1500 minutes (24 ± 1 hr) starting and ending at midnight	Section 4.2.5.3	Critical and MQO
Pre-Sample Collection Purge	Each sampling event	Minimum of ten air changes just prior to sample collection	Section 4.2.5.4	Practical
Field-collected Sample Final Pressure	All field-collected samples	Must be determined with a calibrated pressure gauge or transducer per agency quality system specification	Section 4.2.5.2.4	Operational
Sample Receipt				
Chain-of-custody	All field-collected samples including field QC samples	Each canister must be uniquely identified and accompanied by a valid and legible COC with complete sample documentation	Sections 3.3.1.3.7 and 4.2.5.2.4	Critical

7.1 VOCs via EPA Compendium Method TO-15 (Continued)

Parameter	Description and Required Frequency	Acceptance Criteria	Reference	Category
Sample Holding Time	All field-collected samples, laboratory QC samples, and standards	Analysis within 30 days of end of collection (field-collected samples) or preparation (QC samples or standards)	Section 4.2.1 TO-15 Sections 1.3, 2.3, and 9.2.8.1	Operational
Canister Receipt Pressure Check	All field-collected samples upon receipt at the laboratory – measured with calibrated pressure gauge or transducer	Pressure change of ≤ 0.5 psi from the final pressure at retrieval	Section 4.2.8	Critical for subsambient sample collection, operational for pressurized sample collection
GC/MS Analysis				
Instrument Blank (IB)	Analysis of swept carrier gas through the preconcentrator to demonstrate the instrument is sufficiently clean prior to analysis of ICAL or daily beginning CCV	Each target VOC's concentration < 3x MDL or 0.2 ppb, whichever is lower	Section 4.2.10.5.2.2	Operational
BFB Tune Check	50 ng injection of BFB for tune verification of MS detector analyzed prior to initial calibration and every 24 hours of analysis thereafter (for quadrupole MS only)	Must meet abundance criteria listed in Table 4.2-2	Section 4.2.10.5.1 TO-15 Section 10.4.2	Critical
GC/MS Multi-Point Initial Calibration (ICAL)	Analysis of a minimum of five calibration levels covering approximately 0.1 to 5 ppb Initially and minimally every three months thereafter, following failed BFB tune check, failed CCV, or when changes to the instrument affect calibration response	Average RRF $\leq 30\%$ RSD and each calibration level must be within $\pm 30\%$ of nominal For linear regression (with either a linear or quadratic fit), $r \geq 0.995$ and each calibration level must be within $\pm 30\%$ of nominal	Section 4.2.10.5.2.2 TO-15 Section 10.5.5.1	Critical
Secondary Source Calibration Verification (SSCV)	Analysis of a secondary source standard at the mid-range of the calibration curve to verify ICAL accuracy immediately after each ICAL	Recovery within $\pm 30\%$ of nominal	Section 4.2.10.5.2.3	Critical
Continuing Calibration Verification (CCV)	Analysis of a known standard at the mid-range of the calibration curve to verify ongoing instrument calibration; following each daily BFB tune check and at the conclusion of each analytical sequence	Each target VOC must recover within 70-130% of the nominal spiked amount or the RRF must be within 30% of the mean ICAL RRF	Section 4.2.10.5.2.4 TO-15 Section 10.6.5	Critical

7.1 VOCs via EPA Compendium Method TO-15 (Continued)

Parameter	Description and Required Frequency	Acceptance Criteria	Reference	Category
Internal Standards (IS)	Deuterated or non-naturally occurring compounds co-analyzed with all calibration standards, laboratory QC samples, and field-collected samples so as to monitor instrument response and assess matrix effects	Area response for each IS compound within $\pm 40\%$ of the average response of the ICAL	Section 4.2.10.5.4 TO-15 Section 10.7.5	Critical
Preconcentrator Leak Check	Pressurizing or evacuating each canister connection to the preconcentrator to verify as leak-free prior to analysis	< 0.2 psi change/minute or manufacturer specifications	Section 4.2.10.5.2.1	Operational
Method Blank (MB)	Canister filled with clean humidified diluent gas (gas employed for dilution of standards and /or samples) One with every analysis batch of 20 or fewer field-collected samples	Each target VOC's concentration $< 3 \times$ MDL or 0.2 ppb, whichever is lower	Section 4.2.10.4.3 TO-15 Section 10.7.5	Operational
Laboratory Control Sample (LCS)	Canister spiked with known amount of target analyte at approximately the lower third of the calibration curve <i>Recommended:</i> One with every analysis batch of 20 or fewer field-collected samples	Each target VOC's recovery must be 70 to 130% of its nominal spiked amount	Section 4.2.10.5.2.5	Operational
Retention Time (RT)	RT of each target compound and internal standard for all qualitatively identified compounds and internal standards	Each target VOC's RRT must be within ± 0.06 RRT units of its mean ICAL RRT Each IS RT must be within ± 0.33 minutes of its mean ICAL RT Signal-to-noise $\geq 3:1$	Sections 4.2.10.5.2.2 and 4.2.10.5.4 TO-15 Sections 10.5.5.2, 10.5.5.3, and 10.5.5.4	Critical
Compound Identification	Qualitative identification of each target VOC in each standard, blank, QC sample, and field-collected sample (including field QC samples)	RT within prescribed window Ion abundances of at least one qualifier ion within 30% of ICAL mean Peak apexes co-maximized (within one scan for quadrupole MS) for quantitation and qualifier ions	Section 4.2.10.5.3	Critical
Replicate Analysis	A single additional analysis of a field-collected canister Once with every analysis sequence (as prescribed in workplan)	Precision $\leq 25\%$ RPD for target VOCs with concentrations $\geq 5 \times$ MDL	Section 4.2.10.5.2.5 TO-15 Section 11.1.1	Operational

7.1 VOCs via EPA Compendium Method TO-15 (Continued)

Parameter	Description and Required Frequency	Acceptance Criteria	Reference	Category
Duplicate Sample	Field sample collected through the same inlet probe as the primary sample 10% of primary samples for sites performing duplicate sample collection (as prescribed in workplan)	Precision \leq 25% RPD of primary sample for concentrations \geq 5x MDL	Sections 4.2.4; 4.2.4.1	Operational
Collocated Sample	Field sample collected through a separate inlet probe as the primary sample 10% of primary samples for sites performing duplicate sample collection (as prescribed in workplan)	Precision \leq 25% RPD of primary sample for concentrations \geq 5x MDL	Sections 4.2.4 and 4.2.4.1	Operational
Laboratory Readiness and Proficiency				
Method Detection Limit	Determined initially and minimally annually thereafter and when method changes alter instrument sensitivity	MDL determined via 4.1 must be: Acrolein \leq 0.09 $\mu\text{g}/\text{m}^3$ Benzene \leq 0.13 $\mu\text{g}/\text{m}^3$ 1,3-Butadiene \leq 0.10 $\mu\text{g}/\text{m}^3$ Carbon Tetrachloride \leq 0.017 $\mu\text{g}/\text{m}^3$ Chloroform \leq 0.50 $\mu\text{g}/\text{m}^3$ Tetrachloroethylene \leq 0.17 $\mu\text{g}/\text{m}^3$ Trichloroethylene \leq 0.20 $\mu\text{g}/\text{m}^3$ Vinyl Chloride \leq 0.11 $\mu\text{g}/\text{m}^3$ These MDL MOQs current as of October 2015. Refer to current workplan template for up-to-date MOQs.	Sections 4.1 and 4.2.7	MQO
Stock Standard Gases	Purchased stock standard gases for each target VOC All standards	Certified and accompanied by certificate of analysis Recertified or replaced annually unless a longer expiration is specified by the supplier	Section 4.2.10.3.1	Critical

7.1 VOCs via EPA Compendium Method TO-15 (Continued)

Parameter	Description and Required Frequency	Acceptance Criteria	Reference	Category
Proficiency Testing	Blind sample submitted to each laboratory to evaluate laboratory bias Two per calendar year ¹	Each target compound within $\pm 25\%$ of the assigned target value Failure of one PT must prompt corrective action. Failure of two consecutive PTs (for a specific core analyte) must prompt qualification of the analyte in field collected samples until return to conformance.	Section 2.1.4.1	Operational and MQO
Canister and Sampling Unit Testing and Maintenance				
Canister Leak Test	Testing of the leak tightness of each canister in the agency fleet Annually, may be performed simultaneously with canister zero air check Verification that a canister does not contribute to positive bias over an approximate 30-day period	Leak rate must be ≤ 0.1 psi/day	Section 4.2.6.1.1.1	Operational
Canister Zero Check	<i>Strongly Recommended:</i> Each canister in the agency fleet once annually (or as defined by agency policy) or after major maintenance such as replacement of valve Verification that a canister does not contribute to bias over an approximate 30-day period	All Tier I core target compounds must be < 0.2 ppb or $< 3x$ MDL, whichever is lower	Section 4.2.6.1.1.1 TO-15 Section 8.4.3	Operational
Canister Known Standard Gas Check	<i>Strongly Recommended:</i> Each canister in the agency fleet once annually (or as defined by agency policy) or after major maintenance such as replacement of valve Calibration of sampling unit flow controller	All Tier I core target compounds must be within $\pm 30\%$ of nominal	Section 4.2.6.1.1.2	Operational
Sampling Unit Flow Calibration	Initially and when calibration checks demonstrate flows are out of tolerance, or when components affecting flow are adjusted or replaced	Flow set to match the certified flow primary or transfer standard	Table 3.3-1 TO-15 Section 8.3.5	Practical

7.1 VOCs via EPA Compendium Method TO-15 (Continued)

Parameter	Description and Required Frequency	Acceptance Criteria	Reference	Category
Sampling Unit Non-biasing Certification	Verification that the sampling unit does not contribute to bias Prior to field deployment and annually thereafter, or when flow path components are repaired or replaced Sampling units must be subject to a Zero Check and Known Standard Challenge	Zero Check – All Tier I core target analytes < 0.2 ppb or < 3x MDL, whichever is lower Known Standard Challenge – All Tier I core target analytes within $\pm 15\%$ of the reference sample	Section 4.2.5.5	Operational
Sampling Unit Flow Calibration Check or Audit	Verification of sampling unit flow rate Minimally quarterly, monthly recommended	Flow within $\pm 10\%$ of certified primary or transfer standard flow and design flow	Table 3.3-1	Practical
Site Specifications and Maintenance				
Sampling Unit Siting	Verify conformance to requirements Annually	270° unobstructed probe inlet Inlet 2-15 meters above-ground level ≥ 10 meters from drip line of nearest tree Collocated sampling inlets spaced within 4 meters of primary sampling unit inlet	Section 2.4	Operational
Sample Probe and Inlet	Sample probe and inlet materials composition Annually	Chromatographic grade stainless steel or borosilicate glass	Section 4.2.3.2	Operational
Sample Inlet Filter	Particulate filter maintenance Minimally annually	Clean or replace the 2- μ m sintered stainless steel filter	Section 4.2.3.3 TO-15 Section 7.1.1.5	Operational
Sampling Inlet and Inlet Line Cleaning	Sample inlet and inlet line cleaning or replacement Minimally annually - More often in areas with high airborne particulate levels	Cleaned with distilled water or replaced	Section 4.2.3.1	Operational
Data Reporting				
Data Reporting to AQS	Reporting of all results a given calendar quarter Quarterly, within 180 days of end of calendar quarter	All field-collected sample concentrations reported including data less than MDL. Field QC sample and laboratory replicates must also be reported (as required by workplan).	Section 3.3.1.3.15	Operational

7.1 VOCs via EPA Compendium Method TO-15 (Continued)

Parameter	Description and Required Frequency	Acceptance Criteria	Reference	Category
AQS Reporting Units	Units must be as specified with each submission to AQS	ppbv	Section 3.3.1.3.15	Critical
Data Completeness	Valid samples compared to scheduled samples Annually	≥ 85% of scheduled samples	Section 3.2	MQO

Dependent upon EPA contract with PT provider

7.2 Carbonyls via EPA Compendium Method TO-11A

Parameter	Description and Required Frequency <i>Field Readiness Checks and Collection Activities</i>	Acceptance Criteria	Reference	Category
Collection Media	All field-collected samples and matrix quality control samples	Cartridge containing silica gel solid sorbent coated with DNPH	Section 4.3.5 TO-11A Section 8.2	Critical
Media Handling	All field-collected samples and all quality control samples	Sample retrieval as soon as possible, not to exceed 72 hours post-sampling. Retrieved sample shipped and stored at $\leq 4^{\circ}\text{C}$, protected from light until extraction. Damaged cartridges (water damage or cracked) must be voided.	Sections 4.3.5.2, 4.3.5.3, and 4.3.8.1.2 TO-11A Sections 6.5 and 10.12	Critical
Cartridge Lot Blank Check	Analysis of a minimum of 3 cartridges or 1% of the total lot, whichever is greater, for each new lot	Formaldehyde $< 0.15 \mu\text{g}/\text{cartridge}$, Acetaldehyde $< 0.10 \mu\text{g}/\text{cartridge}$, Acetone $< 0.30 \mu\text{g}/\text{cartridge}$, all others $< 0.10 \mu\text{g}/\text{cartridge}$	Section 4.3.5.1 and Table 4.3-4 TO-11A Section 9.2.5.17	Critical
Sampling Unit Clock/Timer Check	Verified with each sample collection event	Clock/timer accurate to ± 5 minute of reference for digital timers and ± 15 minutes for mechanical timers, set to local standard time	Table 3.3-1	Operational
Sampling Unit Leak Check	Pressurization or evacuation of internal sampler flow paths to demonstrate as leak-free Prior to each sample collection	Sample collection period verified to be midnight to midnight Must show no indicated flow	Section 4.3.8.1.1	Operational
Sampling Frequency	One sample every six days according to the EPA National Monitoring Schedule	Sample must be valid or a make-up sample should be scheduled (refer to Section 2.1.2.1)	Section 4.3.8.1.3	Critical and MQO
Sampling Period	All field-collected samples	1380-1500 minutes (24 ± 1 hr) starting and ending at midnight	Section 4.3.8.1.3	Critical and MQO

7.2 Carbonyls via EPA Compendium Method TO-11A (Continued)

Parameter	Description and Required Frequency	Acceptance Criteria	Reference	Category
Pre-Sample Collection Purge	Each sampling event	Minimum of ten air changes just prior to sample collection	Section 4.3.7.2	Practical
Sample Receipt				
Chain-of-custody	All field-collected samples	Each cartridge must be uniquely identified and accompanied by a valid and legible COC with complete sample documentation	Section 3.3.1.3.7	Critical
Sample Holding Time	All field-collected samples, laboratory QC samples, and standards	Extraction: 14 days from sample collection (cartridge storage $\leq 4^\circ\text{C}$) Analysis: 30 days from extraction (extract storage $\leq 4^\circ\text{C}$)	Section 4.3.9.3 TO-11A Sections 11.1.2 and 11.2.5	Operational
Sample Receipt Temperature Check	All field-collected samples upon receipt at the laboratory	Must be $\leq 4^\circ\text{C}$	Section 4.3.8.1.2 TO-11A Section 10.12	Operational
HPLC Analysis				
Solvent Blank (SB)	Prior to ICAL and daily beginning CCV	All target compounds $< \text{MDL}_{\text{sp}}$ (refer to Section 4.1.3.1) or $s \cdot K$ (refer to Section 4.1.3.2)	Section 4.3.9.5.2	Operational
HPLC Initial Multi-Point Calibration (ICAL)	Initially, following failed CCV, or when changes to the instrument affect calibration response Injection of a minimum of 5 points covering approximately 0.01 to 3.0 $\mu\text{g}/\text{mL}$	Correlation coefficient (r) ≥ 0.999 ; relative error for each level against calibration curve $\leq 20\%$. Absolute value of intercept divided by slope must not exceed MDL_{sp} (MDLs determined by Section 4.1.3.1) or $s \cdot K$ (MDLs determined by Section 4.1.3.2)	Section 4.3.9.5.2 TO-11A Section 11.4.3	Critical
Secondary Source Calibration Verification (SSCV)	Secondary source standard prepared at the mid-range of the calibration curve, analyzed immediately after each ICAL	85 to 115% recovery	Section 4.3.9.5.3 TO-11A Section 11.4.4	Critical
Continuing Calibration Verification (CCV)	Prior to sample analysis on days when an ICAL is not performed and minimally every 12 hours of analysis; recommended following analysis of every 10 field-collected samples and at the conclusion of each analytical sequence	85 to 115% recovery	Section 4.3.9.5.4 TO-11A Section 11.4.5	Critical

7.2 Carbonyls via EPA Compendium Method TO-11A (Continued)

Parameter	Description and Required Frequency	Acceptance Criteria	Reference	Category
Extraction Solvent Method Blank (ESMB)	An aliquot of extraction solvent delivered to a volumetric flask. One with each extraction batch of 20 or fewer field-collected samples.	Each target carbonyl's concentration < MDL _{sp} (refer to Section 4.1.3.1) or s·K (refer to Section 4.1.3.2)	Section 4.3.9.4.1	Operational
Method Blank (MB)	Unexposed DNPH cartridge extracted as a sample One with every extraction batch of 20 or fewer field-collected samples	Formaldehyde < 0.15 µg/cartridge, Acetaldehyde < 0.10 µg/cartridge, Acetone < 0.30 µg/cartridge, all others < 0.10 µg/cartridge	Section 4.3.9.4.1	Operational
Laboratory Control Sample (LCS)	DNPH cartridge spiked with known amount of target analyte at approximately the lower third of the calibration curve, minimally quarterly, one recommended with every extraction batch of 20 or fewer field-collected samples	Formaldehyde recovery 80-120% of nominal spike All others recovery 70-130% of nominal spike	Section 4.3.9.4.1	Operational
Laboratory Control Sample Duplicate (LCSD)	Duplicate LCS to evaluate precision through extraction and analysis, minimally quarterly, one recommended with every extraction batch of 20 or fewer samples	Formaldehyde recovery 80-120% of nominal spike All others recovery 70-130% of nominal spike	Section 4.3.9.4.1	Operational
Retention Time (RT)	Every injection	Precision ≤ 20% RPD of LCS Each target carbonyl's RT within ± 3s or ± 2% of its mean ICAL RT	Section 4.3.9.5.2	Critical
Replicate Analysis	A single additional analysis of a field-collected sample extract Once with every analysis sequence of 20 or fewer samples	Precision ≤ 10% RPD for concentrations ≥ 0.5 µg/cartridge	Section 4.3.9.5.5 TO-11A Section 13.2.3	Operational
Field Blank	Minimally monthly, sample cartridge installed in primary sampling position and exposed to field conditions for minimally 5 minutes	Formaldehyde < 0.30 µg/cartridge, Acetaldehyde < 0.40 µg/cartridge, Acetone < 0.75 µg/cartridge, Sum of all other target compounds < 7.0 µg/cartridge	Section 4.3.8.2.1 TO-11A Section 13.3.1	Operational
Collocated Sample Collection	Field sample collected through a separate inlet probe from the primary sample 10% of primary samples for sites performing collocated sample collection (as prescribed in workplan)	Precision ≤ 20% RPD of primary sample for concentrations ≥ 0.5 µg/cartridge	Section 4.3.8.2.3 TO-11A Section 13.4.1	Operational

7.2 Carbonyls via EPA Compendium Method TO-11A (Continued)

Parameter	Description and Required Frequency	Acceptance Criteria	Reference	Category
Duplicate Sample Collection	Field sample collected through the same inlet probe as the primary sample	Precision $\leq 20\%$ RPD of primary sample for concentrations $\geq 0.5 \mu\text{g}/\text{cartridge}$	Section 4.3.8.2.4 TO-11A Section 13.4.1	Operational
	10% of primary samples for sites performing collocated sample collection (as prescribed in workplan)			
DNPH Chromatography Evaluation	All cartridges	DNPH peak must be present		Critical
	For all field-collected cartridges	DNPH must be $\geq 50\%$ of the DNPH area in the laboratory QC samples	Section 4.3.9.5.7	Critical
Laboratory Readiness and Proficiency				
Proficiency Testing	Blind sample submitted to each laboratory to evaluate laboratory bias	Each target compound within $\pm 25\%$ of the assigned target value		Operational and MQO
	Two per calendar year ¹	Failure of one PT must prompt corrective action. Failure of two consecutive PTs (for a specific core analyte) must prompt qualification of the analyte in field collected samples until return to conformance.	Section 2.1.4.1	
Method Detection Limit	Determined initially and minimally annually thereafter, and when method changes alter instrument sensitivity	MDL must be: Formaldehyde $\leq 0.08 \mu\text{g}/\text{m}^3$ Acetaldehyde $\leq 0.45 \mu\text{g}/\text{m}^3$	Sections 4.1 and 4.3.6	MQO
Stock Standard Solutions	Purchased stock materials for each target carbonyl All standards	These MDL MQOs current as of October 2015. Refer to current workplan template for up-to-date MQOs. Certified and accompanied by certificate of analysis	Section 4.3.9.2.2	Critical
Working Standard Solutions	Storage of all working standards	Stored at $\leq 4^\circ\text{C}$, protected from light	Section 4.3.9.2.4 TO-11A Section 9.4.3	Critical

7.2 Carbonyls via EPA Compendium Method TO-11A (Continued)

Parameter	Description and Required Frequency	Acceptance Criteria	Reference	Category
<i>Sampling Unit Testing and Maintenance</i>				
Field Sampler Flow Rate Calibration	Calibration of sampling unit flow controller	Flow set to match a certified flow transfer standard	Table 3.3-1 and 4.3.7.1.2	Critical
Ozone Scrubber Recharge	Initially and following failure of flow verification checks Recharge ozone scrubber with KI Minimally annually	Scrubber capacity sufficient to be effective (ozone removal > 95%) for 12 months of 24-hour sampling every sixth day	Section 4.3.4.1 TO-11A Section 10.1	Critical
Sampling Unit Non-biasing Certification	Verification with humidified zero air or nitrogen that the sampling unit does not contribute to positive bias Prior to field deployment and annually thereafter, or when flow path components are repaired or replaced	Difference between challenge and reference cartridge < 0.2 ppbv for each target carbonyl	Section 4.3.7.1.1	Operational
Sampling Unit Flow Calibration Check or Audit	Verification of sampling unit flow rate Minimally quarterly, monthly recommended	Flow within \pm 10% of certified primary or transfer standard flow and design flow	Table 3.3-1	Critical
<i>Site Specifications and Maintenance</i>				
Sampling Unit Siting	Verify conformance to requirements Annually	270° unobstructed probe inlet Inlet 2-15 meters above-ground level \geq 10 meters from drip line of nearest tree Collocated sampling inlets spaced no more than 4 meters from primary sampling unit inlet	Section 2.4	Operational
Sample Probe and Inlet	Sample probe and inlet materials composition Annually	Chromatographic grade stainless steel, PTFE Teflon, or borosilicate glass	Section 4.3.7.2	Critical
Sample Inlet Filter	Particulate filter maintenance Minimally annually, if equipped	Clean or replace the inline particulate filter (if equipped)	Section 4.3.7.3	Operational
Sampling Inlet and Inlet Line Cleaning	Sample inlet and inlet line cleaning or replacement Minimally annually - More often in areas with high airborne particulate levels	Cleaned with distilled water or replaced	Section 4.3.7.3	Operational

7.2 Carbonyls via EPA Compendium Method TO-11A (Continued)

Parameter	Description and Required Frequency	Acceptance Criteria	Reference	Category
<i>Data Reporting</i>				
Data Reporting to AQS	Reporting of all results a given calendar quarter Quarterly, within 180 days of end of calendar quarter	All field-collected sample concentrations reported including data less than MDL. All data must be in standard conditions.	Section 3.3.1.3.15	Operational
AQS Reporting Units	Units must be as specified with each quarterly submission to AQS Valid samples compared to scheduled samples	Field QC sample and laboratory replicates must also be reported. mass/volume (ng/m ³ or µg/m ³)	Section 3.3.1.3.15	Critical
Data Completeness	Annually	≥ 85% of scheduled samples	Section 3.2	MQO

7.3 Metals via EPA Compendium Method IO 3.1 and IO 3.5

Parameter	Description and Required Frequency	Acceptance Criteria	Reference	Category
<i>Field Readiness Checks and Collection Activities</i>				
Collection Media	All field-collected samples and matrix quality control samples	Low volume collection: 47-mm Teflon filters with polypropylene support ring and 2- μ m pore size High volume collection: 8" x 10" quartz fiber filter (QFF) filters with 2- μ m pore size	Section 4.4.9.3 40CFR Part 50 Appendix Q Section 6.2.3 Section 4.4.10.3 IO3.1 Section 4.1.6	Critical Critical
Media Inspection	Filters inspected for pinholes, tears, or other imperfections unsuitable for sample collection All filters	Filters with defects must be discarded	Section 4.4.3.3 IO3.1 Section 4.2 IO2.3 Section 7.2	Critical
Media Handling	All field-collected samples and quality control samples	Low volume: Plastic or Teflon coated forceps or powder-free gloves High volume: Plastic or Teflon coated forceps or powder-free gloves	Section 4.4.3.2 IO3.1 Section 5.2.1.1 IO2.3 Section 7.2	Practical Practical
Lot Background Determination	For each new lot of media: <ul style="list-style-type: none"> As part of the MDL process when determining MDLs via Section 4.1.3.1 or <ul style="list-style-type: none"> Five separate filters digested and analyzed 	Low volume: No acceptance criterion Lot blank subtraction is not permitted High volume: No acceptance criterion Lot blank subtraction is not permitted	Section 4.4.9.3.1 Section 4.4.10.3.1 IO3.1 Table 9	Practical Practical
Sampling Unit Clock/Timer Check	Verified with each sample collection event	Clock/timer accurate to ± 5 minute of reference for digital timers and within ± 15 minutes for mechanical timers, set to local standard time Sample collection period verified to be midnight to midnight	Table 3.3-1	Operational

7.3 Metals via EPA Compendium Method IO 3.1 and IO 3.5 (Continued)

Parameter	Description and Required Frequency	Acceptance Criteria	Reference	Category
Sampling Unit Leak Check	Verification that sampling train is leak tight Every five sample collection events	Low volume: Leak rate of ≤ 25 mmHg over 30 seconds or 80 mL/min	Section 4.4.9.4 EPA QA Handbook Vol II Appendix D	Practical
		High volume: absence of a whistle	Section 4.4.10.4 IO2.1 Section 7.3.1.6	Practical
Sampling Frequency	One sample every six days according to the EPA National Monitoring Schedule	Sample must be valid or a make-up sample should be scheduled (refer to Section 2.1.2.1)	Sections 4.4.9.4.1 and 4.4.10.4.1	Critical and MQO
Sampling Period	All field-collected samples	1380-1500 minutes (24 ± 1 hr) starting and ending at midnight	Sections 4.4.9.4.1 and 4.4.10.4.1	Critical and MQO
Pre-Sample Collection Warm-up	Only for high volume sampling units without computer controlled flow	Minimum of five minutes (ten minutes recommended) after filter installation but before sample collection	Section 4.4.10.4 IO2.1 Section 7.4.2.9	Operational
Post-Sample Collection Warm-up	Only for high volume sampling units without computer controlled flow	Minimum of five minutes (ten minutes recommended) before filter retrieval	Section 4.4.10.4 IO2.1 Section 7.4.2.9	Operational
Sample Receipt				
Chain-of-custody	All field-collected samples	Each filter must be uniquely identified and accompanied by a valid and legible COC with complete sample documentation	Section 3.3.1.3.7	Critical
Sample Holding Time	All field-collected samples and laboratory QC samples	Digestion: within 180 days from sample collection or preparation Analysis: within 180 days from sample collection	Section 4.4.1 IO3.1 Section 6.1.2	Operational
Acid Digestion and ICP/MS Analysis				
Microwave Calibration	Standardization of microwave power output			
	Output calibration not to exceed six months; monthly recommended	Level of output should differ by no more than 10% across batches	Section 4.4.9.5.2.2	Operational

7.3 Metals via EPA Compendium Method IO 3.1 and IO 3.5 (Continued)

Parameter	Description and Required Frequency	Acceptance Criteria	Reference	Category
Hot Block Temperature Verification	Reagent water blank with thermometer to ensure digestion temperature consistent for all wells Initially and annually thereafter for each well in the hot block digester	Within $\pm 5^{\circ}\text{C}$ of desired temperature	Section 4.4.9.5.2.1	Operational
Hot Block Temperature Check	Reagent water blank with thermometer to monitor digestion temperature Each digestion batch	Within $\pm 5^{\circ}\text{C}$ of desired temperature	Section 4.4.9.5.2.1	Operational
ICP/MS Warm Up	Warm up of ICP torch and MS detector Each day of analysis	Minimum of 30 minutes (or according to manufacturer specifications) prior to performing initial calibration	Section 4.4.11.6 IO3.5 Section 10.1.1	Practical
ICP/MS Tuning	Analysis of tuning solution containing low (e.g. Li), and medium (e.g. Mg), and high (e.g. Pb) mass elements Each day of analysis during or immediately following warm up	<ul style="list-style-type: none"> • Minimum resolution of 0.75 amu at 5% peak height • Mass calibration within 0.1 amu of unit mass • Five replicates of tuning solution with %RSD $\leq 5\%$ • Manufacturer specifications may be followed 	Section 4.4.11.6 IO3.5 Section 10.1.1	Critical
Initial Calibration Blank (ICB)	Analysis of undigested reagent blank Each day of analysis prior to initial calibration (ICAL) and immediately following the initial calibration verification (ICV)	ICB following ICV: each target element's concentration $< \text{MDL}_{\text{sp}}$ (refer to Section 4.1.3.1) or $s \cdot K$ (refer to Section 4.1.3.2)	Sections 4.4.11.7.1 and 4.4.11.7.3 IO3.5 Section 11.3.3	Critical
ICP/MS Initial Multi-Point Calibration (ICAL)	Minimum of three standard concentration levels plus ICB covering approximately 0.1 to 250 $\mu\text{g/L}$ Each day of analysis, following failed CCV, or returning of the MS	Linear regression correlation coefficient (r) ≥ 0.995 Replicate integrations RSD $\leq 10\%$	Section 4.4.11.7.1	Critical

7.3 Metals via EPA Compendium Method IO 3.1 and IO 3.5 (Continued)

Parameter	Description and Required Frequency	Acceptance Criteria	Reference	Category
Initial Calibration Verification (ICV)	Analysis of second source calibration verification Each day of analysis immediately following ICAL	Within \pm 10% of nominal	Section 4.4.11.7.2 IO3.5 Section 11.3.2	Critical
Interference Check Standard (ICS)	Each day of analysis following the second ICB and every 8 hours of analysis thereafter. Once daily for ICP-MS with collision reaction cells Analysis of two solutions which contain interferences (ICS A) and target elements with known interferences (ICS B)	ICS A: all target elements < 3x MDL _{sp} (refer to Section 4.1.3.1) or 3x s·K (refer to Section 4.1.3.2) – may be subtracted for background indicated on certificate of analysis ICS B: 80 to 120% recovery	Section 4.4.11.7.4 IO3.5 Section 11.3.5	Operational
Continuing Calibration Verification (CCV)	Each day of analysis immediately following the ICS, following every 10 sample injections, and at the conclusion of each analytical sequence	90 to 110% recovery	Section 4.4.11.7.5 IO3.5 Section 11.3.6	Critical
Continuing Calibration Blank (CCB)	Each day of analysis immediately after each CCV	all target elements < MDL _{sp} (refer to Section 4.1.3.1) or s·K (refer to Section 4.1.3.2)	Section 4.4.11.7.6 IO3.5 Section 11.3.7	Critical
Reagent Blank (RB)	Digested reagent blank Once with each extraction batch of 20 or fewer samples	Low volume: All target elements < MDL _{sp} (refer to Section 4.1.3.1) or s·K (refer to Section 4.1.3.2) High volume: All target elements < MDL _{sp} (refer to Section 4.1.3.1) or s·K (refer to Section 4.1.3.2)	Sections 4.4.9.5.1, 4.4.11.7.7, and Table 4.4-3	Operational
Method Blank (MB)	Low volume: Digested blank filter Once with each extraction batch of 20 or fewer samples High volume: Digested blank filter Once with each extraction batch of 20 or fewer samples	Low volume: All target elements < MDL High volume: All target elements < MDL	Sections 4.4.9.5.1, 4.4.11.7.7, and Table 4.4-3	Operational
Reagent Blank Spike (RBS)	Spiked digested reagent blank (no filter)	Low volume: Recovery within 80-120% of nominal for all target elements	Sections 4.4.9.5.1, 4.4.11.7.7, and Table 4.4-3	Operational

7.3 Metals via EPA Compendium Method IO 3.1 and IO 3.5 (Continued)

Parameter	Description and Required Frequency	Acceptance Criteria	Reference	Category
	Once with each digestion batch of 20 or fewer field-collected samples	High volume: Recovery within 80-120% of nominal for all target elements	Sections 4.4.10.5.1, 4.4.11.7.7, and Table 4.4-3	Operational
	Low volume: Digested spiked filter	Low volume: Recovery within 80-120% of nominal for all target elements	Sections 4.4.9.5.1, 4.4.11.7.7, and Table 4.4-3	Operational
Laboratory Control Sample (LCS)	Once with each extraction batch of 20 or fewer field-collected samples High volume: Digested spiked filter strip Once with each extraction batch of 20 or fewer field-collected samples	High volume: Recovery within 80-120% of nominal for all target elements	Sections 4.4.10.5.1, 4.4.11.7.7, and Table 4.4-3 IO3.5 Section 11.3.9	Operational
Laboratory Control Sample Duplicate (LCSD)	Low volume: Duplicate digested spiked filter Once with each extraction batch of 20 or fewer field-collected samples High volume: Duplicate digested spiked filter strip Once with each extraction batch of 20 or fewer field-collected samples	Low volume: Recovery within 80-120% of nominal for all target elements and precision $\leq 20\%$ RPD of LCS High volume: Recovery within 80-120% of nominal for all target elements and precision $\leq 20\%$ RPD of LCS – Not required if batch contains MSD	Sections 4.4.9.5.1, 4.4.11.7.7, and Table 4.4-3	Operational
Duplicate Digested Filter Strip	High volume only Digested duplicate field-collected filter strip Once with each extraction batch of 20 or fewer field-collected samples	Precision $\leq 20\%$ RPD for elements $\geq 5x$ MDL	Sections 4.4.10.5.1, 4.4.11.7.7, and Table 4.4-3 IO3.5 Section 11.3.11	Operational
Matrix Spike (MS)	High volume only Digested spiked field-collected filter strip Once with each extraction batch of 20 or fewer field-collected samples	Recovery within 80-120% of the nominal spiked amount for all target elements – 75-125% for Sb	Sections 4.4.10.5.1, 4.4.11.7.7, and Table 4.4-3 IO3.5 Section 11.3.10	Operational

7.3 Metals via EPA Compendium Method IO 3.1 and IO 3.5 (Continued)

Parameter	Description and Required Frequency	Acceptance Criteria	Reference	Category
Matrix Spike Duplicate (MSD)	High volume only Duplicate digested spiked field-collected filter strip Once with each extraction batch of 20 or fewer field-collected samples	Recovery within 80-120% of the nominal spiked amount for all target elements - 75-125% for Sb and precision \leq 20% RPD of MS	Sections 4.4.10.5.1, 4.4.11.7.7, and Table 4.4-3 IO3.5 Section 11.3.11	Operational
Serial Dilution	Five-fold dilution of a field-collected sample digestate Once with every analysis sequence of 20 or fewer field-collected samples	Recovery of 90-110% of undiluted sample for elements \geq 25x MDL	Section 4.4.11.7.8 IO3.5 Section 11.3.12	Operational
Replicate Analysis	A single additional analysis of a field-collected sample digestate Once with every analysis sequence of 20 or fewer field-collected samples	Precision \leq 10% RPD for concentrations \geq 5x MDL	Section 4.4.11.7.9	Operational
Internal Standards (IS)	Non-target elements added to each analyzed solution at the same concentration Sample filter installed in primary sampling unit for minimally 5 minutes	60 to 125% recovery	Section 4.4.11.4 IO3.5 Section 11.5	Critical
Field Blank	Minimally monthly for primary sampling units, as 18% (approximately 1 out of 5) of collocated samples Field sample collected with a separate sampling unit between 2 and 4 meters from primary sampling unit	All target elements < MDL	Section 4.4.5	Operational
Collocated Sample Collection	10% of primary samples for sites performing collocated sample collection (as prescribed in workplan)	Precision \leq 20% RPD of primary sample for concentrations \geq 5x MDL	Section 4.4.4.1	Operational

7.3 Metals via EPA Compendium Method IO 3.1 and IO 3.5 (Continued)

Parameter	Description and Required Frequency	Acceptance Criteria	Reference	Category
<i>Laboratory Readiness and Proficiency</i>				
Proficiency Testing	Blind sample submitted to each laboratory to evaluate laboratory bias Two per calendar year ¹	Each target compound element within $\pm 25\%$ of the assigned target value Failure of one PT must prompt corrective action. Failure of two consecutive PTs (for a specific core analyte) must prompt qualification of the analyte in field collected samples until return to conformance.	Section 2.1.4.1	Operational and MQO
Method Detection Limit	Determined initially and minimally annually thereafter, with each new lot of filter media, and when method changes alter instrument sensitivity	MDL must be: Arsenic $\leq 0.00023 \mu\text{g}/\text{m}^3$ Beryllium $\leq 0.00042 \mu\text{g}/\text{m}^3$ Cadmium $\leq 0.00056 \mu\text{g}/\text{m}^3$ Lead $\leq 0.15 \mu\text{g}/\text{m}^3$ Manganese $\leq 0.005 \mu\text{g}/\text{m}^3$ Nickel $\leq 0.0021 \mu\text{g}/\text{m}^3$ These MDL MQOs current as of October 2015. Refer to current workplan template for up-to-date MQOs.	Sections 4.1 and 4.4.8	MQO
Stock Standard Solutions	Purchased stock materials for each target element All standards	Certified and accompanied by certificate of analysis	Section 4.4.7	Critical
Working Standard Solutions	Storage of all working standards	Stored in Teflon or suitable plastic bottles	Section 4.4.7 IO3.5 Section 7.2.4	Practical
<i>Sampling Unit Testing and Maintenance</i>				
Field Sampler Flow Rate Calibration	Calibration of sampling unit flow controller Initially and when flow verification checks fail criteria	Flow set to match a certified transfer flow standard	Table 3.3-1 and 4.4.9.2 and 4.4.10.2	Critical

7.3 Metals via EPA Compendium Method IO 3.1 and IO 3.5 (Continued)

Parameter	Description and Required Frequency	Acceptance Criteria	Reference	Category
<p>Sampling Unit Flow Calibration Check</p>	<p>Verification of sampling unit flow rate Minimally quarterly, monthly recommended</p>	<p>Low volume: Within $\pm 4\%$ of certified transfer standard flow and within $\pm 5\%$ of design flow</p> <p>High volume: Within $\pm 7\%$ of certified transfer standard flow and within $\pm 10\%$ of design flow</p>	<p>Table 3.3-1 and 40 CFR 58 Appendix A Section 3.3.3 – EPA QA Guidance Document 2.12</p> <p>Table 3.3-1 and 40 CFR 58 Appendix A Section 3.3.3 EPA QA Handbook Section 2.11.7</p>	<p>Operational</p> <p>Operational</p>

7.3 Metals via EPA Compendium Method IO 3.1 and IO 3.5 (Continued)

Parameter	Description and Required Frequency	Acceptance Criteria	Reference	Category
<i>Site Specifications and Maintenance</i>				
Sampling Unit Siting	Verify conformance to requirements Annually	270° unobstructed probe inlet Inlet 2-15 meters above-ground level ≥ 10 meters from drip line of nearest tree Low volume collocated sampling inlets spaced 1-4 meters from primary sampling unit inlet High volume collocated sampling inlets spaced 2-4 meters from primary sampling unit inlet	Section 2.4 40 CFR Part 58 Appendix E	Operational
<i>Data Reporting</i>				
Data Reporting to AQS	Reporting of all results a given calendar quarter Quarterly, within 1820 days of end of calendar quarter	All field-collected sample concentrations reported including data less than MDL. All data must be in local conditions and may additionally be reported in standard conditions Field QC sample and laboratory replicates must also be reported (as prescribed in workplan)	Section 3.3.1.3.15	Operational
AQS Reporting Units	Units must be as specified With each quarterly submission to AQS	mass/volume (ng/m ³ or µg/m ³)	Section 3.3.1.3.15	Critical
Data Completeness	Valid samples compared to scheduled samples Annually	≥ 85% of scheduled samples	Section 3.2	MQO

7.4 PAHs via EPA Compendium Method TO-13A

Parameter	Description and Required Frequency	Acceptance Criteria	Reference	Category
<i>Field Readiness Checks and Collection Activities</i>				
Collection Media	All field-collected samples and matrix quality control samples	Glass cartridge containing two PUF plugs totaling 3" in height, 15 g styrene-divinyl polymer resin, 104-mm quartz fiber filter with 2- μ m pore size Sample retrieval as soon as possible recommended, preferably within 24 hours, not to exceed 72 hours post-sampling	Section 4.5.3 TO-13A Section 9.1	Critical
Media Handling	All field-collected samples and laboratory quality control samples	Retrieved sample shipped and stored at $\leq 4^{\circ}\text{C}$, protected from light until extraction Damaged cartridges (leaking resin) must be voided.	Section 4.5.4.1 TO-13A Section 11.3.4.10	Operational
Cartridge Lot Blank Check	Analysis of a cartridge from each lot to demonstrate appropriate media cleanliness Minimum of 1 cartridge for each new lot	All target PAHs ≤ 10 ng/cartridge	Section 4.5.3 TO-13A Section 14.2.1	Critical
Sampling Unit Clock/Timer Check	Verified with each sample collection event	Clock/timer accurate to ± 5 minutes of reference for digital timers, within ± 15 minutes for mechanical timers, set to local standard time Sample collection period verified to be midnight to midnight	Table 3.3-1	Operational
Sampling Frequency	One sample every six days according to the EPA National Monitoring Schedule	Sample must be valid or a make-up sample scheduled (refer to Section 2.1.2.1)	Section 4.5.4.1	Critical and MOO
Sampling Period	All field-collected samples	1380-1500 minutes (24 ± 1 hr) starting and ending at midnight	Section 4.5.4.1	Critical and MOO
Sample Flow Rate	All field-collected samples	0.140 to 0.245 m^3/minute for total collection volume of 200 to 350 m^3 (at standard conditions of P = 1 atm and T = 25°C)	Section 4.5.1	Critical
Pre-Sample Collection Warm-up	Only for sampling units without computer controlled flow	Minimum of five minutes (ten minutes are recommended) after sampling head installation but before sample collection	Section 4.5.4 TO-13A Section 11.3.3.3	Practical

7.4 PAHs via EPA Compendium Method TO-13A (Continued)

Parameter	Description and Required Frequency	Acceptance Criteria	Reference	Category
Post-Sample Collection Warm-up	Only for sampling units without computer controlled flow	Minimum of five minutes (ten minutes are recommended) before sampling head retrieval	Section 4.5.4.1	Practical
Sample Receipt				
Chain-of-custody	All field-collected samples including field QC samples	Each cartridge/QFF must be uniquely identified and accompanied by a valid and legible COC with complete sample documentation	Section 3.3.1.3.7	Critical
Sample Holding Time	All field-collected samples and laboratory QC samples	Extraction: 14 days from sample collection (cartridge storage $\leq 4^{\circ}\text{C}$) Analysis: 40 days from extraction (extract storage $\leq 4^{\circ}\text{C}$)	Section 4.5.5.2 TO-13A Section 11.3.4.10	Operational
Sample Receipt Temperature Check	Verification of proper shipping temperature for all field-collected samples upon receipt at the laboratory	Must be $\leq 4^{\circ}\text{C}$ unless delivery time from field site is ≤ 4 hours	Section 4.5.4.1	Operational
Extraction and GC/MS Analysis				
DFTPP Tuning	5-50 ng injected to tune MS prior to ICAL and every 12 hours of analysis thereafter	For GC/MS operated in full scan or SIM/full scan must meet criteria listed in Table 4.5-2	Section 4.5.5.2 TO-13A Section 13.3.3	Critical
Solvent Blank (SB)	Aliquot of solvent analyzed to demonstrate the instrument is sufficiently clean to begin analysis Prior to ICAL and daily beginning CCV	GC/MS operated in SIM mode must tune to meet criteria in Section 4.5.5.2 All target, surrogate, and IS compounds not qualitatively detected	Section 4.5.5.3 TO-13A Section 14.1.2	Critical
GC/MS Initial Multi-Point Calibration (ICAL)	Minimum of 5 points covering approximately 0.1 to 2.0 $\mu\text{g}/\text{mL}$ Initially, following failed CCV, following failed DFTPP tune check, or when changes to the instrument affect calibration response	Average RRF $\leq 30\%$ and each calibration level must be within $\pm 30\%$ of nominal For linear regression (with either a linear or quadratic fit) correlation coefficient (r) ≥ 0.995 and each calibration level within $\pm 30\%$ of nominal	Section 4.5.5.3 TO-13A Section 13.3.4.5	Critical
Secondary Source Calibration Verification (SSCV)	Secondary source standard prepared at the mid-range of the calibration curve, analyzed immediately after each ICAL	70 to 130% recovery of nominal or RRF within $\pm 30\%$ of ICAL average RRG	Section 4.5.5.4	Critical

7.4 PAHs via EPA Compendium Method TO-13A (Continued)

Parameter	Description and Required Frequency	Acceptance Criteria	Reference	Category
Continuing Calibration Verification (CCV)	Mid-range standard analyzed prior to sample analysis on days when an ICAL is not performed, every 12 hours of analysis following the DFPP check, and at the conclusion of each analytical sequence	70 to 130% recovery of nominal or RRF within $\pm 30\%$ of ICAL average RRG	Section 4.5.5.5.5 TO-13A Section 13.3.5.5	Critical
Method Blank (MB)	Unexposed PUF/resin cartridge and QFF extracted as a sample One with every extraction batch of 20 or fewer field-collected samples	All target PAHs < 2x MDL	Section 4.5.5.5.6 TO-13A Section 13.3.6	Operational
Laboratory Control Sample (LCS)	PUF/resin cartridge and QFF spiked with known amount of target analyte at approximately the lower third of the calibration curve Minimally quarterly; recommended one with every extraction batch of 20 or fewer field-collected samples Duplicate LCS to evaluate precision through extraction and analysis	All target PAHs 60-120% recovery of nominal spike	Section 4.5.5.5.6 TO-13A Section 13.3.7	Operational
Laboratory Control Sample Duplicate (LCSD)	Minimally quarterly; recommended one with every extraction batch of 20 or fewer field-collected samples	All target PAHs 60-120% recovery of nominal spike Precision $\leq 20\%$ RPD of LCS	Section 4.5.5.5.6	Operational
Internal Standards	Deuterated homologues of target PAHs added to every injection except beginning SB	50-200% of the area response of the mid-level ICAL standard from ICAL	Section 4.5.5.5.8 TO-13A Section 13.4.7	Critical
Field Surrogate Compounds	Deuterated homologues of target PAHs added to each cartridge before field deployment, also added to cartridges for laboratory and field QC	Recovery 60-120%	Sections 4.5.3.3 and 4.5.5.5.9 TO-13A Section 13.4.6.3	Operational
Extraction Surrogate Compounds	Deuterated homologues of target PAHs added to each extracted field sample, field QC sample, and laboratory QC sample	Recovery 60-120%	Sections 4.5.5.1.4.2 and 4.5.5.5.9 TO-13A Section 13.4.6.3	Operational

7.4 PAHs via EPA Compendium Method TO-13A (Continued)

Parameter	Description and Required Frequency	Acceptance Criteria	Reference	Category
Retention Time (RT)	Every injection	Target and surrogate compound RT within ± 0.06 relative retention time units (RRT) of mean ICAL RRT Internal standard RT within ± 0.33 minute of the most recent CCV	Section 4.5.5.5.3 TO-13A Sections 13.4.6.3 and 13.3.4.5	Critical
Replicate Analysis	A single additional analysis of a field-collected sample extract Once with every analysis sequence of 20 or fewer field-collected samples (as required by workplan)	Precision $\leq 10\%$ RPD for concentrations ≥ 0.5 $\mu\text{g/mL}$	Section 4.5.5.5.6	Operational
Field Blank	Blank sample cartridge installed in sampling unit for minimally five minutes Minimally monthly	All target PAHs $\leq 5x$ MDL	Section 4.5.4.2 TO-13A Section 11.3.4.9	Operational
Collocated Sample Collection	Field sample collected with a separate sampling unit between 2 and 4 meters from primary sampling unit 10% of primary samples for sites performing collocated sample collection (as required by workplan)	Precision $\leq 20\%$ RPD of primary sample for concentrations ≥ 0.5 $\mu\text{g/mL}$	Section 4.5.4.3	Operational
Compound Identification	Qualitative identification of each target PAH in each standard, blank, QC sample, and field-collected sample (including field QC samples)	Signal-to-noise $\geq 3:1$ RT within prescribed window At least one qualifier ion abundance within 15% of ICAL mean Peak apexes co-maximized (within one scan for quadrupole MS) for quantitation and qualifier ions	Section 4.5.5.5.7 TO-13A Section 13.4.3	Critical

7.4 PAHs via EPA Compendium Method TO-13A (Continued)

Parameter	Description and Required Frequency	Acceptance Criteria	Reference	Category
<i>Laboratory Readiness and Proficiency</i>				
Proficiency Testing	Blind sample submitted to each laboratory to evaluate laboratory bias Two per calendar year ¹	Each target compound within $\pm 25\%$ of the assigned target value Failure of one PT must prompt corrective action. Failure of two consecutive PTs (for a specific core analyte) must prompt qualification of the analyte in field collected samples until return to conformance.	Section 2.1.4.1	Operational and MQO
Method Detection Limit	Determined initially and minimally annually thereafter and when method changes alter instrument sensitivity	MDL must be: Benzo(a)pyrene $\leq 0.00091 \mu\text{g}/\text{m}^3$ Naphthalene $\leq 0.029 \mu\text{g}/\text{m}^3$ These MDL MQOs current as of October 2015. Refer to current workplan template for up-to-date MQOs.	Sections 4.1 and 4.5.5.4	MQO
Stock Standard Materials	Purchased stock materials for each target PAH	Certified and accompanied by certificate of analysis	Section 4.5.5.1.2	Critical
Working Standard Solutions	All standards Storage of all working standards	Stored at $\leq -10^\circ\text{C}$, protected from light	Section 4.5.5.2	Critical
<i>Sampling Unit Testing and Maintenance</i>				
Field Sampler Flow Rate Calibration	Calibration of sampling unit flow controller Initially, when flow verification checks fail criteria, or when instrument maintenance changes flow characteristics of the sampling unit	Flow set to match a certified flow transfer standard	Table 3.3-1 and 4.5.2.1	Critical
Sampling Unit Flow Calibration Check or Audit	Verification of sampling unit flow rate Minimally quarterly, monthly recommended	Flow within $\pm 10\%$ of certified primary or transfer standard flow and design flow	Table 3.3-1	Critical
<i>Site Specifications and Maintenance</i>				
Sampling Unit Siting	Verify conformance to requirements Annually	270° unobstructed probe inlet Inlet 2-15 meters above-ground level ≥ 10 meters from drip line of nearest tree Collocated sampling inlets spaced 2-4 meters from primary sampling unit inlet	Section 2.4	Operational

7.4 PAHs via EPA Compendium Method TO-13A (Continued)

Parameter	Description and Required Frequency	Acceptance Criteria	Reference	Category
<i>Data Reporting</i>				
Data Reporting to AQS	Reporting of all results a given calendar quarter Quarterly, within 180 days of end of calendar quarter	All field-collected sample concentrations reported including data less than MDL. All data must be in standard conditions. Field QC sample and laboratory replicates must also be reported.	Section 3.3.1.3.15	Operational
AQS Reporting Units	Units must be as specified With each quarterly submission to AQS	mass/volume (ng/m ³ or µg/m ³)	Section 3.3.1.3.15	Critical
Data Completeness	Valid samples compared to scheduled samples Annually	≥ 85% of scheduled samples	Section 3.2	MQO

APPENDIX A
DRAFT REPORT
ON
DEVELOPMENT OF DATA QUALITY OBJECTIVES (DQOS) FOR
THE NATIONAL AMBIENT AIR TOXICS TRENDS
MONITORING NETWORK
SEPTEMBER 27, 2002

September 27, 2002

DRAFT REPORT

on

**DEVELOPMENT OF DATA QUALITY OBJECTIVES (DQOS) FOR THE
NATIONAL AMBIENT AIR TOXICS TRENDS MONITORING NETWORK**

**Contract No. 68-D-98-030
Work Assignment 5-12**

for

**Sharon Nizich
Work Assignment Manager**

**Vickie Presnell
Project Officer**

**Office of Air Quality Planning and Standards
Emissions, Monitoring, and Analysis Division
U.S. ENVIRONMENTAL PROTECTION AGENCY
Research Triangle Park, North Carolina 27711**

Prepared by

**BATTELLE
505 King Avenue
Columbus, Ohio 43201-2693**

BATTELLE DISCLAIMER

This report is a work prepared for the United States Environmental Protection Agency by Battelle Memorial Institute. In no event shall either the United States Environmental Protection Agency or Battelle Memorial Institute have any responsibility or liability for any consequences of any use, misuse, inability to use, or reliance upon the information contained herein, nor does either warrant or otherwise represent in any way the accuracy, adequacy, efficacy, or applicability of the contents hereof.

TABLE OF CONTENTS

	<u>Page</u>
EXECUTIVE SUMMARY	v
1.0 INTRODUCTION.....	1
2.0 THE GENERAL DQO PROCESS	1
2.1 State the Problem.....	2
2.2 Identify the Decision	3
2.3 Identify the Inputs to the Decision	3
2.4 Define the Study Boundaries.....	4
2.5 Develop a Decision Rule	4
2.6 Specify Tolerable Limits on the Decision Errors	5
2.7 Optimize the Design	6
3.0 DQOS FOR THE SIX STUDY COMPOUNDS	6
3.1 DQOs for Measuring the Percent Decrease of Benzene at Urban Locations.....	9
3.2 DQOs for Measuring the Percent Decrease of Benzene at Rural Locations	10
3.3 DQOs for Measuring the Percent Decrease of 1,3-Butadiene at Urban Locations	11
3.4 DQOs for Measuring the Percent Decrease of 1,3-Butadiene at Rural Locations.....	12
3.5 DQOs for Measuring the Percent Decrease of Arsenic at Urban Locations	13
3.6 DQOs for Measuring the Percent Decrease of Arsenic at Rural Locations	14
3.7 DQOs for Measuring the Percent Decrease of Chromium.....	15
3.8 DQOs for Measuring the Percent Decrease of Acrolein	16
3.9 DQOs for Measuring the Percent Decrease of Formaldehyde at Urban Locations	17
3.10 DQOs for Measuring the Percent Decrease of Formaldehyde at Rural Locations	18
APPENDIX A: ESTIMATES OF THE DQO PARAMETERS MEASURING ENVIRONMENTAL VARIABILITY	A-1

List of Tables

Table 3.1.1	DQO input parameters for benzene at urban locations	9
Table 3.1.2	DQO output parameters for benzene at urban locations	9
Table 3.2.1	DQO input parameters for benzene at rural locations.....	10
Table 3.2.2	DQO output parameters for benzene at rural locations	10
Table 3.3.1	DQO input parameters for 1,3-butadiene at urban locations	11
Table 3.3.2	DQO output parameters for 1,3-butadiene at urban locations	11
Table 3.4.1	DQO input parameters for 1,3-butadiene at rural locations	12
Table 3.4.2	DQO output parameters for 1,3-butadiene at rural locations	12
Table 3.5.1	DQO input parameters for arsenic at urban locations.....	13
Table 3.5.2	DQO output parameters for arsenic at urban locations	13
Table 3.6.1	DQO input parameters for arsenic at rural locations.....	14
Table 3.6.2	DQO output parameters for arsenic at rural locations.....	14
Table 3.7.1	DQO input parameters for chromium	15
Table 3.7.2	DQO output parameters for chromium.....	15
Table 3.8.1	DQO input parameters for acrolein	16
Table 3.8.2	DQO output parameters for acrolein	16
Table 3.9.1	DQO input parameters for formaldehyde at urban locations	17
Table 3.9.2	DQO output parameters for formaldehyde at urban locations	17
Table 3.10.1	DQO input parameters for formaldehyde at rural locations	18
Table 3.10.2	DQO output parameters for formaldehyde at rural locations	18

List of Figures

Figure 3.1.1	Power curve for detecting a 15 percent decrease between 3-year means of benzene concentrations based on the data verification found in urban locations of the Pilot Study	9
Figure 3.2.1	Power curve for detecting a 15 percent decrease between 3-year means of benzene concentrations based on the data variation found in rural locations of the Pilot Study	10
Figure 3.3.1	Power curve for detecting a 15 percent decrease between 3-year means of 1,3-butadiene concentrations based on the data variation found in urban locations of the Pilot Study	11
Figure 3.4.1	Power curve for detecting a 15 percent decrease between 3-year means of 1,3-butadiene concentrations based on the data variation found in rural locations of the Pilot Study	12
Figure 3.5.1	Power curve for detecting a 15 percent decrease between 3-year means of arsenic concentrations based on the data variation found in urban locations of the Pilot Study	13
Figure 3.6.1	Power curve for detecting a 15 percent decrease between 3-year means of arsenic concentrations based on the data variation found in rural locations of the Pilot Study	14
Figure 3.7.1	Power curve for detecting a 15 percent decrease between 3-year means of chromium concentrations based on the data variation found in the Pilot Study	15
Figure 3.8.1	Power curve for detecting a 15 percent decrease between 3-year means of acrolein concentrations based on the data variation found in the Pilot Study	16
Figure 3.9.1	Power curve for detecting a 15 percent decrease between 3-year means of formaldehyde concentrations based on the data variation found in urban locations of the Pilot Study	17
Figure 3.10.1	Power curve for detecting a 15 percent decrease between 3-year means of formaldehyde concentrations based on the data variation found in rural locations of the Pilot Study	18

EXECUTIVE SUMMARY

The Data Quality Objective (DQO) process described in EPA's QA/G-4 document provides a general framework for ensuring that the data collected by EPA meets the needs of decision makers and data users. The process establishes the link between the specific end use(s) of the data with the data collection process and the data quality (and quantity) needed to meet a program's goals. This process was applied to one of the primary goals of the National Air Toxics Monitoring Network, namely to establish trends and evaluate the effectiveness of HAP reduction strategies. This report documents the results of the DQO process for the local monitoring data requirements for: benzene, 1,3-butadiene, arsenic, chromium, acrolein, and formaldehyde.

The technical approach used followed the conceptual model developed for the PM_{2.5} Federal Reference Method (FRM) DQOs. This conceptual model of simulating daily deviations from a seasonal curve was followed mainly due to its success in use with PM_{2.5} and the flexibility of the conceptual model. It is a quite general model for simulating the characterization of ambient concentrations in terms of annual or multi-year averages from 1 in n day sampling. The model incorporates several sources of variability: seasonal variability, natural day-to-day variability, sampling incompleteness, and measurement error. The measurement error was restricted to a precision component without a bias component, because the mathematical form of the assessment of trends is robust to multiplicative bias. Pollutant specific parameters were used in the modeling. The parameters describing the natural variation of the pollutants were based on data analyses of the Pilot City data and EPA's Air Toxics Data Archive. Finally, separate urban and rural DQOs were established for the pollutants that were sufficiently measured in rural locations of the Pilot Study.

While there are pollutant specific requirements with respect to measurement detection limits, the DQOs established all fall into the same framework. Each pollutant needs to be measured on a schedule of at least once every six days with at least an 85 percent quarterly completeness. The measurement precision needs to be controlled with a coefficient of variation no more than 15 percent. Under these conditions, true decreasing trends of 30 percent or more can be detected at least 90 percent of the time between successive three-year periods. Moreover, the error rate for when there is no true change between successive three-year periods is controlled to be at most 10 percent. Sampling frequency and natural or environmental day-to-day variation are the primary factors affecting these error rates.

1.0 INTRODUCTION

The Data Quality Objective (DQO) process described in EPA's QA/G-4 document provides a general framework for ensuring that the data collected by EPA meets the needs of the intended decision makers and data users. The process establishes the link between the specific end use(s) of the data with the data collection process and the data quality (and quantity) needed to meet a program's goals. This process was applied to one of the primary goals of the National Air Toxics Monitoring Network, namely to establish trends and evaluate the effectiveness of HAP reduction strategies. This report documents the results of the DQO process for the local monitoring data requirements for: benzene, 1,3-butadiene, arsenic, chromium, acrolein, and formaldehyde.

The technical approach used followed the conceptual model developed for the PM_{2.5} FRM DQOs. This conceptual model was followed mainly due to its success in use with PM_{2.5} and the flexibility of the conceptual model. It is a quite general model for simulating the characterization of ambient concentrations in terms of annual or multi-year averages from 1 in n day sampling. The model incorporates several sources of variability: seasonal variability, natural day-to-day variability, sampling incompleteness, and measurement error. The measurement error was restricted to a precision component without a bias component because the final mathematical form of the assessment of trends is robust to multiplicative bias. Pollutant specific parameters were used in the modeling. The parameters describing the natural variation of the pollutants were based on data analyses of the Pilot City data and the Air Toxics Archive. Finally, separate urban and rural DQOs were established for the pollutants that were sufficiently measured in rural locations of the Pilot Study.

A workgroup organized by EPA/OAQPS/EMAD provided representatives of data users, decision makers, state and local parties, and monitoring and laboratory personnel. Battelle provided technical statistical support throughout the process with examples and data analyses. The workgroup guided the DQO development and made the decisions that were not driven by data analyses in the DQO development during a series of conference calls. These decisions included items such as establishing a specific mathematical form for measuring trends and establishing limits on the sampling rate. Battelle and EPA also held a meeting in Research Triangle Park, North Carolina, on June 17, 2002 to discuss the development details.

2.0 THE GENERAL DQO PROCESS

This section presents an overview of the seven steps in EPA's QA/G-4 DQO process as applied to one of the primary goals of the National Air Toxics Monitoring Network, namely to establish trends and evaluate the effectiveness of HAP reduction strategies (see www.epa.gov/quality/qa_docs.html). The purpose of this section is to provide general discussion on the specific issues that were used in developing the DQOs as they relate to the general DQO process.

The DQO process is a seven-step process based on the scientific method to ensure that the data collected by EPA meet the needs of its data users and decision makers in terms of the

information to be collected, in particular the desired quality and quantity of data. It also provides a framework for checking and evaluating the program goals to make sure they are feasible and that the data are collected efficiently. The seven steps are usually labeled as:

- State the Problem
- Identify the Decision
- Identify the Inputs to the Decision
- Define the Study Boundaries
- Develop a Decision Rule
- Specify Tolerable Limits on the Decision Errors
- Optimize the Design.

This section has general discussion for each of these items. The pollutant specific outcomes of the DQO process are contained in Section 3.

2.1 State the Problem

Characterize the ambient concentrations in the region represented by the monitor to establish any significant downward trend (measured by a percent change between successive 3-year means of the concentrations).

The ability to characterize the trends was statistically modeled. The statistical model was designed by starting with a model similar to the one used for PM_{2.5} FRM data. The ambient concentrations are modeled as deviations from a sine curve, where the sine curve represents seasonality. This sine curve represents long-term daily averages of the concentrations that one would observe at the site. The form used is as follows:

$$A \left[1 + \left(\frac{r-1}{r+1} \right) \sin \left(\frac{day}{365} 2 \pi \right) \right]$$

where

- A = the long term annual average and
- r = the ratio of the highest point on the sine curve to the lowest point. (A value of r = 1 indicates no seasonality.)

The natural deviations from the sine curve are assumed to follow a lognormal distribution with a mean that is given by the particular point on the sine curve. (For example, the value of the

sine curve for Day 100 is the mean for all Day 100s across many years.) The coefficient of variation (CV) of the lognormal distribution is assumed to be a constant. The general model considered also allows for the day-to-day deviations from the sine curve to be correlated, but the current DQOs are based on a correlation of zero. (The correlation effectively measures how quickly the concentrations can change from one deviation from the sine curve to another. A correlation of zero indicates that it can change fast enough that values measured on consecutive days would be completely independent. A value of 0.2 would say that a positive deviation from the curve is somewhat more likely to be followed by another positive deviation than a negative deviation. A value of 0.9 would indicate that positive deviations are almost always followed by another positive deviation.) Finally, the measured values are modeled with a normally distributed random measurement error with a constant coefficient of variation (CV). The specific values for the various parameters are pollutant specific.

The population parameters (the degree of seasonality, the autocorrelation, and the CV of the deviations from the sine curve) were estimated from the Pilot City data (and in the case of benzene compared with estimates from the Air Toxics Data Archive). (See Appendix A.) A near worst-case choice was made for each of the parameters. The power curves and decision errors are established via Monte-Carlo simulation of the model with the particular parameters for various combinations of truth and observed percent changes in three-year mean concentrations. The power curves are plotted as functions of the true percent change in the three-year annual means for compound specific combinations of the sampling frequency, completeness, and precision. Decision errors are stated for these worst-case scenarios.

Note: It was decided by the workgroup from budgetary considerations that the proposed DQOs should be constrained to no more than one in six day sampling.

2.2 Identify the Decision

The decision statement should provide a link between the principal study question and possible actions. The potential actions associated with achieving or failing to achieve a particular percent decrease in the observed three-year mean concentration were not defined by the workgroup. However, it was decided that any decision would be based on whether or not a 15 percent decrease was observed. Hence the form of the decision was fixed, and may be specified as follows:

Significant decreases (15 percent or more) between successive three-year mean concentration levels will result in ... Insignificant decreases, (increases, or decreases of less than 15 percent) will trigger alternate actions of .

2.3 Identify the Inputs to the Decision

Only six HAPs (benzene, 1,3-butadiene, arsenic, chromium, acrolein, and formaldehyde) were considered in the DQO development. It is assumed that the other pollutants will be represented by at least one of these six. The statements included here apply implicitly to the other HAPs.

It is assumed that the analytical techniques used in the Pilot study will be used throughout the program. Most importantly for the DQOs the Method Detection Limits (MDLs) will not increase. The pollutant specific MDLs assumed are listed in Section 3. Those values were identified as pollutant-site maximums that were achieved by at least two of the pilot sites in each pollutant's case.

Among the key decisions made as a part of the DQO process was that each pollutant will need to be measured on a schedule of at least once every six days with a quarterly completeness of 85 percent for six consecutive years. The completeness criterion was checked against the pilot data, and was generally achieved. All valid measurements count toward the completeness goal, including non-detects. The analysis of the trends at the site level will be based on a percent difference between the mean of the first three annual concentrations and the mean of the last three annual concentrations. Hence for each year the annual average concentration, X_i , needs to be found, $i = 1, 2, \dots 6$. Next find the mean, X , for the first three years and the mean, Y , for years 4 through 6 as follows:

$$X = \frac{X_1 + X_2 + X_3}{3} \text{ and } Y = \frac{X_4 + X_5 + X_6}{3}.$$

Then the downward trend, T , is the percent decrease from the first three-year period to the second three-year period. Namely,

$$T = \frac{X - Y}{X} \cdot 100.$$

The Action Level is the cutoff point that separates different decision alternatives. Based on the assumed budgetary constraint of one in six day sampling and the natural variation exhibited by the six compounds considered, an action level of 15 percent was chosen. Hence at least a 15 percent decrease between the two distinct three-year mean concentrations will need to be observed in order to be considered a significant decrease. This assumes that the mean concentrations are above the health standards, and hence it makes sense to consider trends. (Note that characterizing the mean concentrations is a separate goal of the Air Toxics program that has not yet been considered and could result in different DQOs.)

2.4 Define the Study Boundaries

It is desired that the specific location of the monitors be constrained so that they represent neighborhood scale assessment for each of the two three-year periods under consideration. The details of how to ensure this goal have not yet been determined. Some guideline is provided by the Air Toxics Monitoring Concept Paper (see <http://www.epa.gov/ttn/antic/airtxfil.html>).

2.5 Develop a Decision Rule

The decision rule is an "if ... then" statement for how the various alternatives will be chosen. As noted above the specific alternative actions have not been formalized yet, just the form of the decision rule.

If the percent change between successive three-year average concentration levels is greater than or equal to 15 percent, then ...Otherwise ...

2.6 Specify Tolerable Limits on the Decision Errors

Since the program will not generate complete, error-free data, there will be some probability of making a decision error. The main goal of the DQO process is to find a workable balance between how complete and error free the data are with acceptable levels of decision errors. To find the balance, the possible errors need to be carefully defined. This usually needs to be done with the recognition that there will be a range, often called the gray zone, where it is impractical to control decision errors.

The QA/G-4 guidance recommends using 0.01 as the starting point for setting decision error rates. However, such a limit would generally require a sampling rate that is not feasible. The workgroup decided on the following limits:

If there is no true decrease in the three-year average concentrations, then the probability of observing a mean concentration for years four through six that is at least 15 percent below the observed mean concentration from years one through three should be no more than 10 percent.

If there is a true decrease in the three-year average concentrations of at least 30 percent, then the probability of observing a mean concentration for years four through six that is less than 15 percent below the observed mean concentration from years one through three should be no more than 10 percent.

Equivalently, the second statement could read that:

If there is a true decrease in the three-year average concentrations of at least 30 percent, then the probability of observing a mean concentration for years four through six that is at least 15 percent below the observed mean concentration from years one through three should be at least 90 percent.

The power curves shown in Section 3 show the probability of observing at least a 15 percent decrease as a function of the true decrease. In terms of the above goals this means that the power curve graphs should start below 10 percent for a true percent change of 0 and end above 90 percent for a true percent change of 30 percent. Since there is a particular interest in the error rates for no true change and for a true change of a 30 percent decrease, this associated x-axis (horizontal axis) range is shown for each curve. Also, it is sometimes useful to know when the two target error rates are achieved. The range of "truth" between these values is referred to as the gray zone, i.e., the range of true percent decreases that cannot be reliably detected by the sampling scheme. These are also given for each curve (and indicated with vertical dotted lines).

2.7 Optimize the Design

In each pollutant's case, a sampling schedule of once every six days is set forth with a quarterly completeness criteria of 85 percent. Pilot City study participants were surveyed and almost all were collecting and obtaining valid data values at a rate that exceeded 85 percent for each of the six compounds considered (valid non-detects counted toward completeness). Hence, the target rate of 85 percent was selected, instead of the more common 75 percent completeness goal. This should make the power curves more representative of the network's expected monitoring conditions.

3.0 DQOS FOR THE SIX STUDY COMPOUNDS

This section states the design values, namely it gives the expected maximum error rates, gray zones, and power curves for each of the six compounds considered explicitly. The parameters describing the natural state of the ambient conditions used to construct the power curves, error rates and gray zone are compound specific based on data from the Pilot Study. (See Appendix A.) In each case, the Pilot City data yielded a range of estimates. The specific values used were the extremes (or nearly so) that would make detecting a downward trend more difficult. Actual performance in almost all cases should be better than that indicated by the power curves, since specific sites would not be characterized by these extremes in each of these parameters. However, since the sensitivity to the different parameters is not the same, the DQOs need to protect against a combined set of extremes. Hence, the use of extremes for network design purposes is conservative.

Since the rural sites can be quite different from urban sites, separate DQOs are shown in those cases where there were sufficient data to support investigating a separate set of DQOs. In the case of formaldehyde, the urban and rural DQOs are essentially the same.

There are twelve input parameters shown in each section. They are:

1. T1. This is the target error rate for when there is no change. It is always 10 percent.
2. T2. This is the target error rate for when there is a 30 percent decrease. It is always 10 percent.
3. The action limit. This is the minimum observed percent change from the mean concentration of the first three years to the mean concentration from the last three years that would be used to indicate that the concentrations have decreased. Decreases less than this amount would not be considered significant decreases in the mean concentration.
4. The sampling rate. It is set to one in six day sampling in each case.
5. The quarterly completeness criterion. This was set to 85 percent based on the recommendation of ERG and a review of the Pilot Study data completeness.

6. Measurement error Coefficient of Variation (CV). This was assumed to be 15 percent for each compound. (A sensitivity analysis showed that the DQOs are robust to moderate changes in this value.)
7. Seasonality ratio. This is a measure of the degree of seasonality. Specifically, it is the ratio of the highest point on the seasonal curve to the lowest point. A value of 1 indicates no seasonality. Larger values make it more difficult to estimate an annual or three-year mean concentration, and hence larger values make it more difficult to measure the percent change.
8. Autocorrelation. This is a measurement of how quickly day-to-day deviation from the seasonal curve can occur. A value of 0 indicates that changes occur quickly enough that each day is independent of the preceding day. Values greater than 0 indicate that the changes are generally slower, so that days with concentrations above the seasonal curve are more likely to be followed by another day above the seasonal curve. Values greater than 0 increase the precision of the three-year means and the percent change between the three-year means. Hence, a value of 0 is the most conservative choice for the DQOs. Zero was used in all cases, because many daily measurements are required to obtain a reliable estimate of this parameter.
9. Population CV. This is a measurement of the natural variation about the seasonal curve. Larger values decrease the precision of the three-year mean concentration estimates and the percent change between them. The power curves are strongly dependent on this parameter, but the estimates can be strongly influenced by a few outlier values. Generally the 90th percentile of the estimates from the Pilot study was used as a balance between these competing forces. This value was then rounded up to be a multiple of 5 percent for the urban DQOs. For the rural DQOs an additional 5 percent was added, since there were fewer rural sites on which to base the estimates.
10. MDL. This is the MDL used in the simulations. The value was chosen to be a reasonably attainable maximum for a site and compound.
11. Initial mean concentration. This is the mean concentration of the first three years in the simulations. Values closer to the MDL decrease the precision of the percent change estimate. The value chosen was approximately equal to the 25th percentile of the site-compound means from the Pilot study.
12. Health Risk Standard. This value is shown for reference only. It was not used in the simulations.

In addition to the power curves, there are three sets of output values.

1. Error₀ is the percent of the simulations with no change in the true three-year means that in fact generated at least a 15 percent decrease in the observed three-year means.

2. Error₃₀ is the percent of the simulations with a 30 percent decrease in the true three-year means that generated less than a 15 percent decrease in the observed three-year means.
3. The gray zone is the interval of the true decreases that cannot be detected with confidence by the study design. In this range, the probability of observing at least a 15 percent decrease is greater than 10 percent, but less than 90 percent.

In summary, based on variability and uncertainty estimates from the ten-city Pilot Study, the following Sections 3.1 through 3.10 suggest that the specified air toxics trends DQOs will be met for monitoring sites that satisfy the goals of 1 in 6 day sampling, 85 percent completeness, and 15 percent measurement CV. These results were explicitly developed for benzene (urban and rural); 1,3-butadiene (urban and rural); arsenic (urban and rural); chromium (urban only); acrolein (urban only); and formaldehyde (urban and rural).

3.1 DQOs for Measuring the Percent Decrease of Benzene at Urban Locations

Table 3.1.1 shows the input parameters used in the simulation model in developing the DQOs for measuring the percent decrease between three-year mean concentrations of benzene at urban locations. Table 3.1.2 shows the output values from the simulations. Figure 3.1.1 shows the associated power curve, which is the probability of observing a 15 percent difference between successive three-year means as a function of the true percent difference in the distinct three-year means. In summary, based on variability and uncertainty estimates from the ten-city Pilot Study data, Table 3.1.2 suggests that the specified air toxics trends DQOs will be met for benzene at urban monitoring sites that satisfy the goals of one in six-day sampling, 85 percent completeness, and 15 percent measurement CV. (See section 3.0 for definitions of the input parameters and output values.)

Table 3.1.1 DQO input parameters for benzene at urban locations

T1	Action Limit	Sampling Rate	Seasonality	Population CV	Initial Concentration ($\mu\text{g}/\text{m}^3$)
10%	15%	1 in 6 day	4.5	85%	1.0
T2	Measurement CV	Completeness	Autocorrelation	MDL ($\mu\text{g}/\text{m}^3$)	Risk Standard ($\mu\text{g}/\text{m}^3$)
10%	15%	85%	0	0.044	0.128

Table 3.1.2 DQO output parameters for benzene at urban locations

Error rate for no true change	Error rate for 30% decrease	Gray zone
6%	97%	3% - 26%

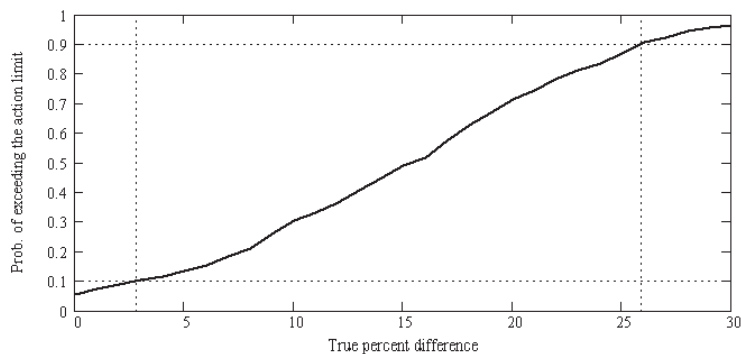

Figure 3.1.1 Power curve for detecting a 15 percent decrease between successive three-year means of benzene concentrations based on the data variation found in urban locations of the Pilot Study

3.2 DQOs for Measuring the Percent Decrease of Benzene at Rural Locations

Table 3.2.1 shows the input parameters used in the simulation model in developing the DQOs for measuring the percent decrease between three-year mean concentrations of benzene at rural locations. Table 3.2.2 shows the output values from the simulations. Figure 3.2.1 shows the associated power curve, which is the probability of observing a 15 percent difference between successive three-year means as a function of the true percent difference in the distinct three-year means. In summary, based on variability and uncertainty estimates from the ten-city Pilot Study data, Table 3.2.2 suggests that the specified air toxics trends DQOs will be met for benzene at rural monitoring sites that satisfy the goals of one in six-day sampling, 85 percent completeness, and 15 percent measurement CV. (See section 3.0 for definitions of the input parameters and output values.)

Table 3.2.1 DQO input parameters for benzene at rural locations

T1	Action Limit	Sampling Rate	Seasonality	Population CV	Initial Concentration ($\mu\text{g}/\text{m}^3$)
10%	15%	1 in 6 day	4.0	60%	1.0
T2	Measurement CV	Completeness	Autocorrelation	MDL ($\mu\text{g}/\text{m}^3$)	Risk Standard ($\mu\text{g}/\text{m}^3$)
10%	15%	85%	0	0.044	0.128

Table 3.2.2 DQO output parameters for benzene at rural locations

Error rate for no true change	Error rate for 30% decrease	Gray zone
2%	99%	7% - 23%

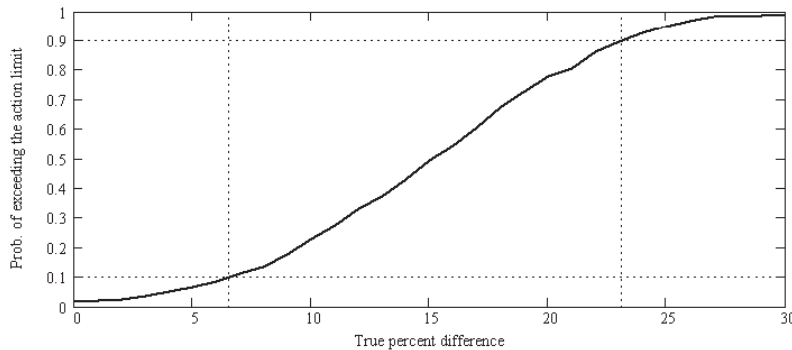

Figure 3.2.1 Power curve for detecting a 15 percent decrease between successive three-year means of benzene concentrations based on the data variation found in rural locations of the Pilot Study

3.3 DQOs for Measuring the Percent Decrease of 1,3-Butadiene at Urban Locations

Table 3.3.1 shows the input parameters used in the simulation model in developing the DQOs for measuring the percent decrease between three-year mean concentrations of 1,3-butadiene at urban locations. Table 3.3.2 shows the output values from the simulations. Figure 3.3.1 shows the associated power curve, which is the probability of observing a 15 percent difference between successive three-year means as a function of the true percent difference in the distinct three-year means. In summary, based on variability and uncertainty estimates from the ten-city Pilot Study data, Table 3.3.2 suggests that the specified air toxics trends DQOs will be met for 1,3-butadiene at urban monitoring sites that satisfy the goals of one in six-day sampling, 85 percent completeness, and 15 percent measurement CV. (See section 3.0 for definitions of the input parameters and output values.)

Table 3.3.1 DQO input parameters for 1,3-butadiene at urban locations

T1	Action Limit	Sampling Rate	Seasonality	Population CV	Initial Concentration ($\mu\text{g}/\text{m}^3$)
10%	15%	1 in 6 day	7.0	100%	0.1
T2	Measurement CV	Completeness	Autocorrelation	MDL ($\mu\text{g}/\text{m}^3$)	Risk Standard ($\mu\text{g}/\text{m}^3$)
10%	15%	85%	0	0.02	10^{-9}

Table 3.3.2 DQO output parameters for 1,3-butadiene at urban locations

Error rate for no true change	Error rate for 30% decrease	Gray zone
10%	94%	0% - 28%

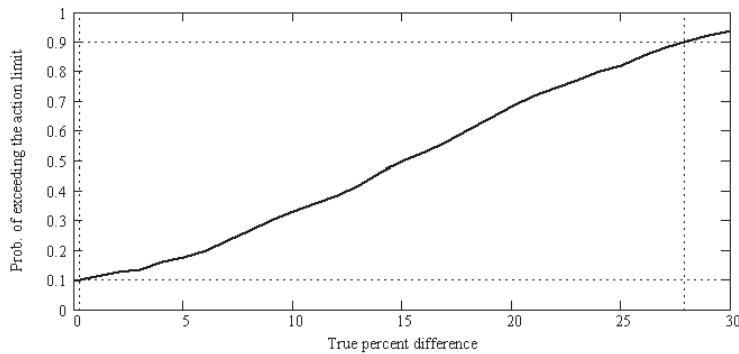

Figure 3.3.1 Power curve for detecting a 15 percent decrease between successive three-year means of 1,3-butadiene concentrations based on the data variation found in urban locations of the Pilot Study

3.4 DQOs for Measuring the Percent Decrease of 1,3-butadiene at Rural Locations

Table 3.4.1 shows the input parameters used in the simulation model in developing the DQOs for measuring the percent decrease between three-year mean concentrations of 1,3-butadiene at rural locations. Table 3.4.2 shows the output values from the simulations. Figure 3.4.1 shows the associated power curve, which is the probability of observing a 15 percent difference between successive three-year means as a function of the true percent difference in the distinct three-year means. In summary, based on variability and uncertainty estimates from the ten-city Pilot Study data, Table 3.4.2 suggests that the specified air toxics trends DQOs will be met for 1,3-butadiene at rural monitoring sites that satisfy the goals of one in six-day sampling, 85 percent completeness, and 15 percent measurement CV. (See section 3.0 for definitions of the input parameters and output values.)

Table 3.4.1 DQO input parameters for 1,3-butadiene at rural locations

T1	Action Limit	Sampling Rate	Seasonality	Population CV	Initial Concentration ($\mu\text{g}/\text{m}^3$)
10%	15%	1 in 6 day	6.0	75%	0.1
T2	Measurement CV	Completeness	Autocorrelation	MDL ($\mu\text{g}/\text{m}^3$)	Risk Standard ($\mu\text{g}/\text{m}^3$)
10%	15%	85%	0	0.02	10^{-9}

Table 3.4.2 DQO output parameters for 1,3-butadiene at rural locations

Error rate for no true change	Error rate for 30% decrease	Gray zone
4%	98%	4% - 25%

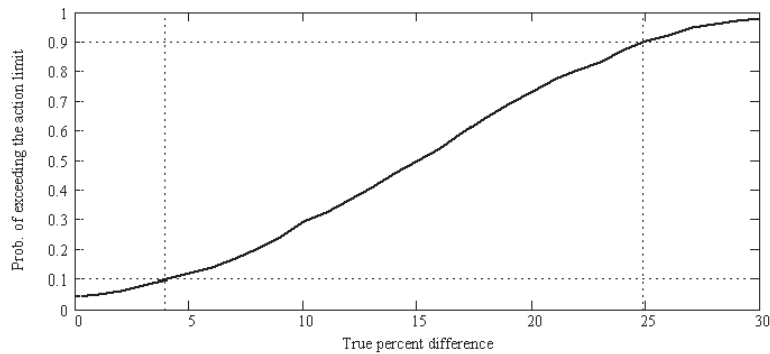

Figure 3.4.1 Power curve for detecting a 15 percent decrease between successive three-year means of 1,3-butadiene concentrations based on the data variation found in rural locations of the Pilot Study

3.5 DQOs for Measuring the Percent Decrease of Arsenic at Urban Locations

Table 3.5.1 shows the input parameters used in the simulation model in developing the DQOs for measuring the percent decrease between three-year mean concentrations of arsenic at urban locations. Table 3.5.2 shows the output values from the simulations. Figure 3.5.1 shows the associated power curve, which is the probability of observing a 15 percent difference between successive three-year means as a function of the true percent difference in the distinct three-year means. In summary, based on variability and uncertainty estimates from the ten-city Pilot Study data, Table 3.5.2 suggests that the specified air toxics trends DQOs will be met for arsenic at urban monitoring sites that satisfy the goals of one in six-day sampling, 85 percent completeness, and 15 percent measurement CV. (See section 3.0 for definitions of the input parameters and output values.)

Table 3.5.1 DQO input parameters for arsenic at urban locations

T1	Action Limit	Sampling Rate	Seasonality	Population CV	Initial Concentration ($\mu\text{g}/\text{m}^3$)
10%	15%	1 in 6 day	5.0	85%	0.002
T2	Measurement CV	Completeness	Autocorrelation	MDL ($\mu\text{g}/\text{m}^3$)	Risk Standard ($\mu\text{g}/\text{m}^3$)
10%	15%	85%	0	0.000046	0.0043

Table 3.5.2 DQO output parameters for arsenic at urban locations

Error rate for no true change	Error rate for 30% decrease	Gray zone
8%	95%	2% - 27%

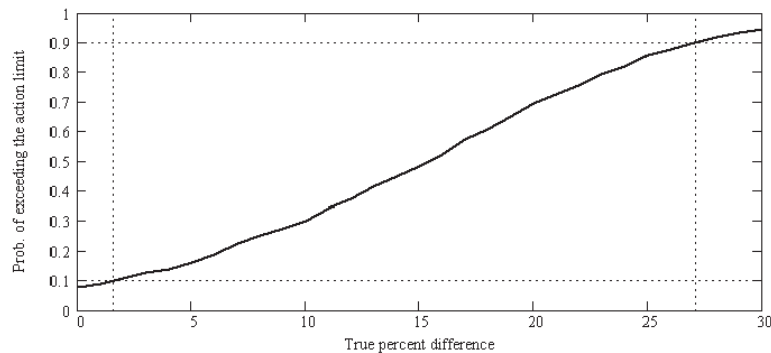

Figure 3.5.1 Power curve for detecting a 15 percent decrease between successive three-year means of arsenic concentrations based on the data variation found in urban locations of the Pilot Study

3.6 DQOs for Measuring the Percent Decrease of Arsenic at Rural Locations

Table 3.6.1 shows the input parameters used in the simulation model in developing the DQOs for measuring the percent decrease between three-year mean concentrations of arsenic at rural locations. Table 3.6.2 shows the output values from the simulations. Figure 3.6.1 shows the associated power curve, which is the probability of observing a 15 percent difference between successive three-year means as a function of the true percent difference in the distinct three-year means. In summary, based on variability and uncertainty estimates from the ten-city Pilot Study data, Table 3.6.2 suggests that the specified air toxics trends DQOs will be met for arsenic at rural monitoring sites that satisfy the goals of one in six-day sampling, 85 percent completeness, and 15 percent measurement CV. (See section 3.0 for definitions of the input parameters and output values.)

Table 3.6.1 DQO input parameters for arsenic at rural locations

T1	Action Limit	Sampling Rate	Seasonality	Population CV	Initial Concentration ($\mu\text{g}/\text{m}^3$)
10%	15%	1 in 6 day	4.0	65%	0.001
T2	Measurement CV	Completeness	Autocorrelation	MDL ($\mu\text{g}/\text{m}^3$)	Risk Standard ($\mu\text{g}/\text{m}^3$)
10%	15%	85%	0	0.000046	0.0043

Table 3.6.2 DQO output parameters for arsenic at rural locations

Error rate for no true change	Error rate for 30% decrease	Gray zone
3%	99%	5% - 24%

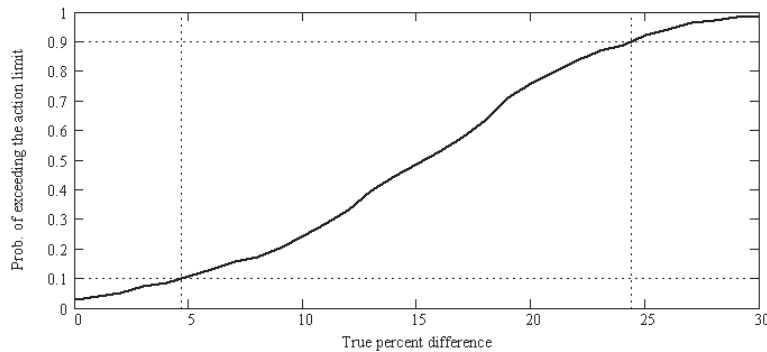

Figure 3.6.1 Power curve for detecting a 15 percent decrease between successive three-year means of arsenic concentrations based on the data variation found in rural locations of the Pilot Study

3.7 DQOs for Measuring the Percent Decrease of Chromium

Table 3.7.1 shows the input parameters used in the simulation model in developing the DQOs for measuring the percent decrease between three-year mean concentrations of chromium. Table 3.7.2 shows the output values from the simulations. Figure 3.7.1 shows the associated power curve, which is the probability of observing a 15 percent difference between successive three-year means as a function of the true percent difference in the distinct three-year means. In summary, based on variability and uncertainty estimates from the ten-city Pilot Study data, Table 3.7.2 suggests that the specified air toxics trends DQOs will be met for chromium at monitoring sites that satisfy the goals of one in six-day sampling, 85 percent completeness, and 15 percent measurement CV. (See section 3.0 for definitions of the input parameters and output values.)

Table 3.7.1 DQO input parameters for chromium

T1	Action Limit	Sampling Rate	Seasonality	Population CV	Initial Concentration ($\mu\text{g}/\text{m}^3$)
10%	15%	1 in 6 day	5.0	90%	0.0015
T2	Measurement CV	Completeness	Autocorrelation	MDL ($\mu\text{g}/\text{m}^3$)	Risk Standard ($\mu\text{g}/\text{m}^3$)
10%	15%	85%	0	0.00018	0.012

Table 3.7.2 DQO output parameters for chromium

Error rate for no true change	Error rate for 30% decrease	Gray zone
7%	96%	2% - 27%

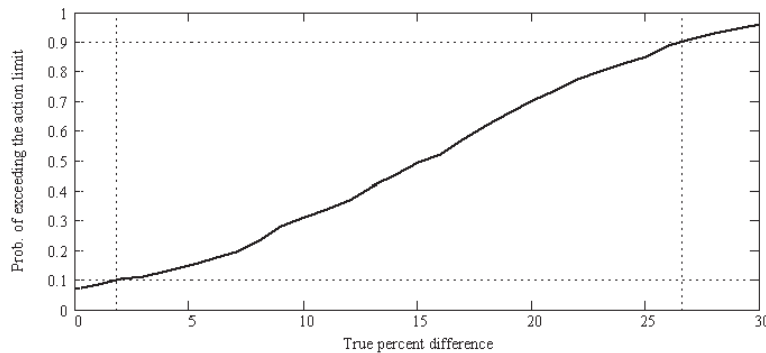

Figure 3.7.1 Power curve for detecting a 15 percent decrease between successive three-year means of chromium concentrations based on the data variation found in of the Pilot Study

3.8 DQOs for Measuring the Percent Decrease of Acrolein

Table 3.8.1 shows the input parameters used in the simulation model in developing the DQOs for measuring the percent decrease between three-year mean concentrations of acrolein. Table 3.8.2 shows the output values from the simulations. Figure 3.8.1 shows the associated power curve, which is the probability of observing a 15 percent difference between successive three-year means as a function of the true percent difference in the distinct three-year means. In summary, based on variability and uncertainty estimates from the ten-city Pilot Study data, Table 3.8.2 suggests that the specified air toxics trends DQOs will be met for acrolein at monitoring sites that satisfy the goals of one in six-day sampling, 85 percent completeness, and 15 percent measurement CV. (See section 3.0 for definitions of the input parameters and output values.)

Table 3.8.1 DQO input parameters for acrolein

T1	Action Limit	Sampling Rate	Seasonality	Population CV	Initial Concentration ($\mu\text{g}/\text{m}^3$)
10%	15%	1 in 6 day	4.0	105%	0.4
T2	Measurement CV	Completeness	Autocorrelation	MDL ($\mu\text{g}/\text{m}^3$)	Risk Standard ($\mu\text{g}/\text{m}^3$)
10%	15%	85%	0	0.14	-

Table 3.8.2 DQO output parameters for acrolein

Error rate for no true change	Error rate for 30% decrease	Gray zone
10%	91%	0% - 29%

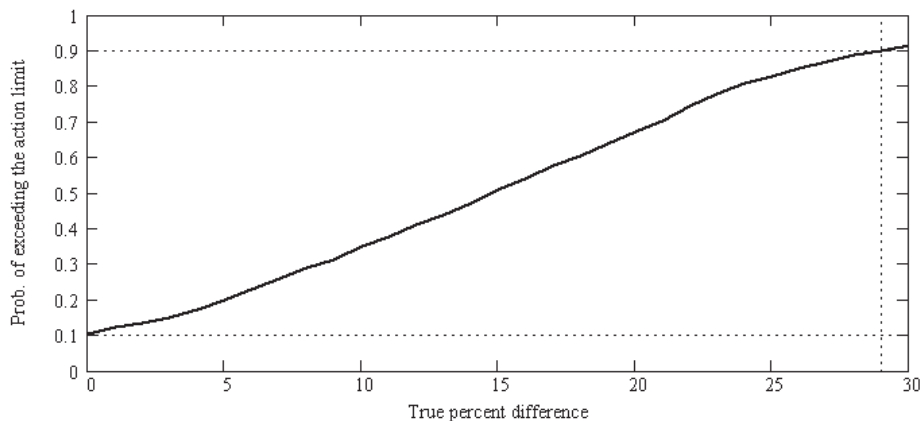

Figure 3.8.1 Power curve for detecting a 15 percent decrease between successive three-year means of acrolein concentrations based on the data variation found in the Pilot Study

3.9 DQOs for Measuring the Percent Decrease of Formaldehyde at Urban Locations

Table 3.9.1 shows the input parameters used in the simulation model in developing the DQOs for measuring the percent decrease between three-year mean concentrations of formaldehyde at urban locations. Table 3.9.2 shows the output values from the simulations. Figure 3.9.1 shows the associated power curve, which is the probability of observing a 15 percent difference between successive three-year means as a function of the true percent difference in the distinct three-year means. In summary, based on variability and uncertainty estimates from the ten-city Pilot Study data, Table 3.9.2 suggests that the specified air toxics trends DQOs will be met for formaldehyde at urban monitoring sites that satisfy the goals of one in six-day sampling, 85 percent completeness, and 15 percent measurement CV. (See Section 3.0 for definitions of the input parameters and output values.)

Table 3.9.1 DQO input parameters for formaldehyde at urban locations

T1	Action Limit	Sampling Rate	Seasonality	Population CV	Initial Concentration ($\mu\text{g}/\text{m}^3$)
10%	15%	1 in 6 day	7.0	90%	2.5
T2	Measurement CV	Completeness	Autocorrelation	MDL ($\mu\text{g}/\text{m}^3$)	Risk Standard ($\mu\text{g}/\text{m}^3$)
10%	15%	85%	0	0.014	$1.3 \cdot 10^{-5}$

Table 3.9.2 DQO output parameters for formaldehyde at urban locations

Error rate for no true change	Error rate for 30% decrease	Gray zone
8%	95%	2% - 27%

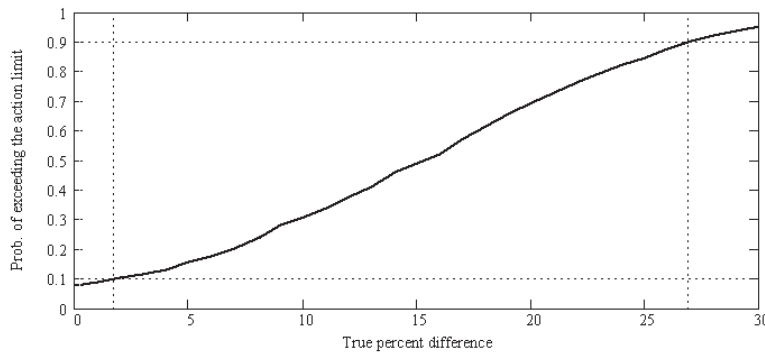

Figure 3.9.1 Power curve for detecting a 15 percent decrease between successive three-year means of formaldehyde concentrations based on the data variation found in urban locations of the Pilot Study

3.10 DQOs for Measuring the Percent Decrease of Formaldehyde at Rural Locations

Table 3.10.1 shows the input parameters used in the simulation model in developing the DQOs for measuring the percent decrease between three-year mean concentrations of formaldehyde at rural locations. Table 3.10.2 shows the output values from the simulations. Figure 3.10.1 shows the associated power curve, which is the probability of observing a 15 percent difference between successive three-year means as a function of the true percent difference in the distinct three-year means. In summary, based on variability and uncertainty estimates from the ten-city Pilot Study data, Table 3.10.2 suggests that the specified air toxics trends DQOs will be met for formaldehyde at rural monitoring sites that satisfy the goals of one in six-day sampling, 85 percent completeness, and 15 percent measurement CV. (See Section 3.0 for definitions of the input parameters and output values.)

Table 3.10.1 DQO input parameters for formaldehyde at rural locations

T1	Action Limit	Sampling Rate	Seasonality	Population CV	Initial Concentration ($\mu\text{g}/\text{m}^3$)
10%	15%	1 in 6 day	7.0	90%	2.1
T2	Measurement CV	Completeness	Autocorrelation	MDL ($\mu\text{g}/\text{m}^3$)	Risk Standard ($\mu\text{g}/\text{m}^3$)
10%	15%	85%	0	0.014	$1.3 \cdot 10^{-5}$

Table 3.10.2 DQO output parameters for formaldehyde at rural locations

Error rate for no true change	Error rate for 30% decrease	Gray zone
8%	95%	1% - 27%

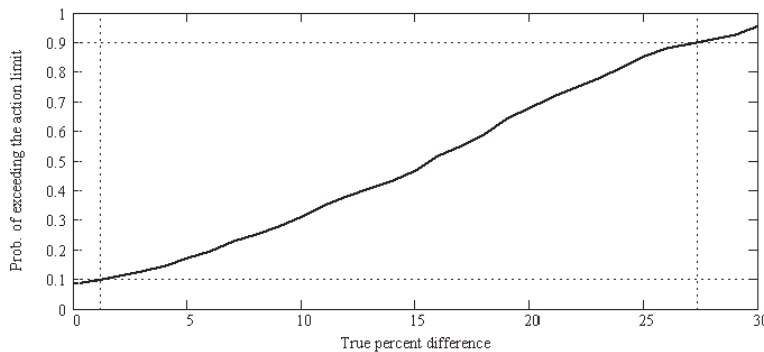

Figure 3.10.1 Power curve for detecting a 15 percent decrease between successive three-year means of formaldehyde concentrations based on the data variation found in rural locations of the Pilot Study

APPENDIX A:
ESTIMATES OF THE DQO PARAMETERS MEASURING
ENVIRONMENTAL VARIABILITY

Appendix A: Estimates of the DQO Parameters Measuring Environmental Variability

The DQO parameters that measure the natural environmental variability of a pollutant are generally uncontrollable parameters that have a strong effect on the decision errors. The simulation model described in Section 2.1 uses these parameters. This appendix describes both the parameters and the method for estimating the parameters from the Pilot data. The basic simulation model is that the true concentration levels vary about a sinusoidal curve with one full oscillation in each year. Four parameters describe characteristics of the sine curve and the natural deviations from the sine curve.

Seasonality Ratio

The ratio parameter is a measure of the degree of seasonality in the data. It is the ratio of the high point to the low point on the sine curve. The model assumes that the amplitude of the sine curve is proportional to the mean. The parameter was estimated by finding the monthly averages and taking the ratio of the highest average to the lowest average. The site estimates are restricted to those sites that had at least 3 measurements in each of at least six months.

Population CV

This parameter measures the amount of random, day-to-day variation of the true concentration about the sine curve. This parameter was estimated as follows. Starting with every 6th day measurements (deleting if needed), the natural log of each measurement was found. Next, a new sequence of numbers was created equal to the differences of successive pairs in the sequence of the log-concentrations that were from measurements taken six days apart. Finally, terms were removed from this sequence so that each term in the remaining sequence was based on distinct numbers. Let S be the standard deviation of this set of numbers. The estimate for the population CV is $\sqrt{(\exp(S^2/2)-1)}$. The site estimates are restricted to those with at least ten terms being used in the estimates.

Autocorrelation

The final parameter describing the natural variation of the true concentrations is autocorrelation. This is a measurement of the similarity between successive days. Consider two sets of measurements. First, suppose you had measured the concentrations on every July 15th for the past five years. You would expect those five values to be rather spread out. The population CV should capture how different these measurements are from each other. On the other hand, suppose instead you measure the concentrations each day from July 15, 2002, to July 20, 2002. These values may not be as spread out as the other set, simply because they are nearer in time to each other. Autocorrelation measures this effect. A good way to think of autocorrelation is it measures how quickly the local concentrations can change. The value of the autocorrelation ranges between 0 and 1. A value of 0 means that the local concentrations can change very rapidly from day-to-day. A value of 1 means that the local concentrations are constant.

Estimating autocorrelation is more difficult than estimating the population CV. Unless a site had daily measurements, a value of 0 was used. Realistically, 0 is the most conservative case and can always be used. Assuming a site had daily measurements, let S_6 be the standard deviation computed as in the section on population CV, based on differences of the logs from every 6th day measurements. Let S_1 be the same thing using differences of logs from daily measurements. If $S_6 > S_1$, then the autocorrelation was estimated with $(S_6^2 - S_1^2)/S_6^2$. This method adjusts for seasonality, but still tends to slightly over estimate the truth. There were too few sites with sufficient daily measurements to obtain distributions of the pollutant autocorrelations, so a value of 0 was used for all pollutants.

Initial concentration.

This is simply the mean concentration for the site.

Table A-1 gives the pollutant and site estimates for the seasonality ratio and the initial mean concentrations. Table A-2 gives the pollutant and site population CV estimates.

Table A-1. Estimates of the seasonality ratio and initial mean by pollutant and site

Pollutant	Site ID	Urban / Rural	Mean ($\mu\text{g}/\text{m}^3$)	Seasonality Ratio
1,3-BUTADIENE	2616300051	Urban	0.3190	3.60
1,3-BUTADIENE	4400700261	Urban	0.2600	3.15
1,3-BUTADIENE	2616300331	Urban	0.2067	2.65
1,3-BUTADIENE	2616300271	Urban	0.2032	2.03
1,3-BUTADIENE	2612500101	Urban	0.2027	1.36
1,3-BUTADIENE	4400700221	Urban	0.1789	5.86
1,3-BUTADIENE	1210300181	Urban	0.1732	4.41
1,3-BUTADIENE	4400700251	Urban	0.1431	4.07
1,3-BUTADIENE	1205710751	Urban	0.1382	5.43
1,3-BUTADIENE	1210310081	Urban	0.1272	3.31
1,3-BUTADIENE	5303300321	Urban	0.1250	6.51
1,3-BUTADIENE	1210350021	Urban	0.1164	2.50
1,3-BUTADIENE	5303300801	Urban	0.1148	5.76
1,3-BUTADIENE	5303300241	Urban	0.1141	7.10
1,3-BUTADIENE	4400700241	Urban	0.1041	4.64
1,3-BUTADIENE	4400710101	Urban	0.1019	5.35
1,3-BUTADIENE	5303300201	Urban	0.1010	10.03
1,3-BUTADIENE	5303300101	Urban	0.0916	10.39
1,3-BUTADIENE	5303300381	Urban	0.0809	5.51
1,3-BUTADIENE	4400300021	Urban	0.0358	5.38
1,3-BUTADIENE	0807700131	Rural	0.2192	6.00
1,3-BUTADIENE	0807700161	Rural	0.1810	4.06
1,3-BUTADIENE	1311300391	Rural	0.1182	3.23
1,3-BUTADIENE	1311300371	Rural	0.0886	1.22
ACROLEIN	4400700261	Urban	0.5904	2.04
ACROLEIN	4400700221	Urban	0.5866	3.36
ACROLEIN	4400700241	Urban	0.5366	2.36
ACROLEIN	4400700251	Urban	0.5366	2.18
ACROLEIN	4400710101	Urban	0.3637	3.34
ACROLEIN	4400300021	Urban	0.3509	3.69
ARSENIC TSP	1205710751	Urban	0.0038	5.01
ARSENIC TSP	2616300271	Urban	0.0033	2.06
ARSENIC TSP	2616300331	Urban	0.0028	3.13
ARSENIC TSP	1210350021	Urban	0.0027	2.94
ARSENIC TSP	1205700811	Urban	0.0027	1.59
ARSENIC TSP	1205710651	Urban	0.0026	1.40
ARSENIC TSP	2616300151	Urban	0.0024	2.68
ARSENIC TSP	1210300181	Urban	0.0024	2.41
ARSENIC TSP	2616300051	Urban	0.0023	2.82
ARSENIC TSP	1210310081	Urban	0.0022	1.56
ARSENIC TSP	2616300011	Urban	0.0021	4.50
ARSENIC TSP	2616300191	Urban	0.0019	2.97
ARSENIC TSP	5303300241	Urban	0.0015	4.48
ARSENIC TSP	2612500101	Urban	0.0014	14.99

Table A-1. Estimates of the seasonality ratio and initial mean by pollutant and site (Cont'd.)

Pollutant	Site ID	Urban / Rural	Mean $\mu\text{g}/\text{m}^3$	Seasonality Ratio
ARSENIC TSP	5303300201	Urban	0.0010	3.80
ARSENIC TSP	5303300381	Urban	0.0009	3.13
ARSENIC TSP	5303300101	Urban	0.0008	4.94
ARSENIC TSP	0807700161	Rural	0.0016	2.11
ARSENIC TSP	0807700131	Rural	0.0008	3.54
BENZENE	2616300271	Urban	18.8411	12.42
BENZENE	2616300051	Urban	2.2038	1.92
BENZENE	2612500101	Urban	2.0860	1.59
BENZENE	2616300331	Urban	2.0710	1.55
BENZENE	5303300321	Urban	1.7124	3.97
BENZENE	5303300241	Urban	1.6500	2.76
BENZENE	4400700261	Urban	1.4416	2.43
BENZENE	1210300181	Urban	1.2763	3.09
BENZENE	4400700221	Urban	1.2648	3.49
BENZENE	5303300801	Urban	1.1697	1.71
BENZENE	5303300101	Urban	1.1466	2.08
BENZENE	5303300381	Urban	1.1161	2.30
BENZENE	4400700251	Urban	1.1123	3.30
BENZENE	1205710751	Urban	1.0364	2.98
BENZENE	5303300201	Urban	1.0229	2.03
BENZENE	1210310081	Urban	0.9283	2.62
BENZENE	1210350021	Urban	0.8940	1.94
BENZENE	4400700241	Urban	0.8849	3.06
BENZENE	1205710651	Urban	0.8791	2.47
BENZENE	4400710101	Urban	0.8006	4.15
BENZENE	1205700811	Urban	0.6451	2.37
BENZENE	4400300021	Urban	0.4190	5.05
BENZENE	0807700131	Rural	2.7088	2.36
BENZENE	0807700161	Rural	1.8649	3.16
BENZENE	1311300391	Rural	1.1701	2.68
BENZENE	0606530111	Rural	1.0166	3.10
BENZENE	1311300371	Rural	0.9221	1.66
BENZENE	0606530121	Rural	0.7622	2.71
CHROMIUM TSP	2616300271	Urban	0.0075	1.70
CHROMIUM TSP	2616300331	Urban	0.0061	1.68
CHROMIUM TSP	2616300151	Urban	0.0059	2.09
CHROMIUM TSP	2616300051	Urban	0.0049	1.90
CHROMIUM TSP	2616300011	Urban	0.0036	2.31
CHROMIUM TSP	2612500101	Urban	0.0034	1.79
CHROMIUM TSP	2616300191	Urban	0.0031	2.45
CHROMIUM TSP	1205710651	Urban	0.0019	1.62
CHROMIUM TSP	1210350021	Urban	0.0017	3.68
CHROMIUM TSP	5303300201	Urban	0.0017	6.25
CHROMIUM TSP	1210300181	Urban	0.0016	2.51

Table A-1. Estimates of the seasonality ratio and initial mean by pollutant and site (Cont'd.)

Pollutant	Site ID	Urban / Rural	Mean ($\mu\text{g}/\text{m}^3$)	Seasonality Ratio
CHROMIUM TSP	1205700811	Urban	0.0014	1.87
CHROMIUM TSP	1210310081	Urban	0.0014	2.99
CHROMIUM TSP	1205710751	Urban	0.0014	1.88
CHROMIUM TSP	5303300241	Urban	0.0011	4.23
CHROMIUM TSP	5303300381	Urban	0.0009	3.02
CHROMIUM TSP	5303300101	Urban	0.0009	3.17
FORMALDEHYDE	2616300331	Urban	7.2980	70.55
FORMALDEHYDE	1210300181	Urban	4.1605	2.36
FORMALDEHYDE	4400710101	Urban	4.0325	2.80
FORMALDEHYDE	1205710651	Urban	3.8291	2.25
FORMALDEHYDE	4400700251	Urban	3.6958	2.53
FORMALDEHYDE	2616300271	Urban	3.5940	1.64
FORMALDEHYDE	4400700261	Urban	3.4373	2.36
FORMALDEHYDE	1205700811	Urban	3.4311	2.38
FORMALDEHYDE	4400700221	Urban	3.3888	2.01
FORMALDEHYDE	1210310081	Urban	3.2569	2.56
FORMALDEHYDE	1205710751	Urban	2.9991	2.73
FORMALDEHYDE	2612500101	Urban	2.8279	2.21
FORMALDEHYDE	1210350021	Urban	2.8150	2.31
FORMALDEHYDE	2616300191	Urban	2.7887	4.43
FORMALDEHYDE	4400700241	Urban	2.6769	3.25
FORMALDEHYDE	2616300011	Urban	2.4937	2.98
FORMALDEHYDE	5303300801	Urban	1.7148	2.97
FORMALDEHYDE	5303300321	Urban	1.4839	3.56
FORMALDEHYDE	5303300381	Urban	1.3536	2.53
FORMALDEHYDE	5303300201	Urban	1.3236	3.78
FORMALDEHYDE	5303300241	Urban	1.1373	2.48
FORMALDEHYDE	5303300101	Urban	1.0165	9.43
FORMALDEHYDE	0807700131	Rural	7.3046	6.72
FORMALDEHYDE	0807700161	Rural	7.0664	2.15
FORMALDEHYDE	1311300371	Rural	2.3401	5.10
FORMALDEHYDE	1311300391	Rural	2.1613	3.02
FORMALDEHYDE	0606530121	Rural	2.1246	2.83
FORMALDEHYDE	0606530111	Rural	1.6840	1.90

Table A-2. Population CV estimates by pollutant and site

Pollutant	SITE ID	Urban / Rural	State	County	Population CV
1,3-BUTADIENE	530330032	Urban	WA	King County	109.2%
1,3-BUTADIENE	530330024	Urban	WA	King County	106.7%
1,3-BUTADIENE	530330010	Urban	WA	King County	97.4%
1,3-BUTADIENE	530330038	Urban	WA	King County	85.8%
1,3-BUTADIENE	440070025	Urban	RI	Providence County	84.2%
1,3-BUTADIENE	530330020	Urban	WA	King County	79.6%
1,3-BUTADIENE	261630027	Urban	MI	Wayne County	78.0%
1,3-BUTADIENE	261250010	Urban	MI	Oakland County	74.7%
1,3-BUTADIENE	440071010	Urban	RI	Providence County	74.1%
1,3-BUTADIENE	530330080	Urban	WA	King County	72.4%
1,3-BUTADIENE	261630033	Urban	MI	Wayne County	67.8%
1,3-BUTADIENE	121030018	Urban	FL	Pinellas County	67.5%
1,3-BUTADIENE	440070024	Urban	RI	Providence County	64.5%
1,3-BUTADIENE	440070022	Urban	RI	Providence County	63.8%
1,3-BUTADIENE	120571075	Urban	FL	Hillsborough County	62.9%
1,3-BUTADIENE	440070026	Urban	RI	Providence County	61.7%
1,3-BUTADIENE	261630005	Urban	MI	Wayne County	59.5%
1,3-BUTADIENE	121031008	Urban	FL	Pinellas County	57.9%
1,3-BUTADIENE	120571065	Urban	FL	Hillsborough County	57.6%
1,3-BUTADIENE	121035002	Urban	FL	Pinellas County	55.7%
1,3-BUTADIENE	440030002	Urban	RI	Kent County	54.1%
1,3-BUTADIENE	120570081	Urban	FL	Hillsborough County	32.7%
1,3-BUTADIENE	080770013	Rural	CO	Mesa County	69.8%
1,3-BUTADIENE	080770016	Rural	CO	Mesa County	67.1%
1,3-BUTADIENE	131130039	Rural	GA	Fayette County	34.5%
1,3-BUTADIENE	131130037	Rural	GA	Fayette County	13.4%
ACROLEIN	440030002	Urban	RI	Kent County	100.3%
ACROLEIN	440071010	Urban	RI	Providence County	80.7%
ACROLEIN	440070024	Urban	RI	Providence County	66.4%
ACROLEIN	440070022	Urban	RI	Providence County	58.7%
ACROLEIN	440070026	Urban	RI	Providence County	53.4%
ACROLEIN	440070025	Urban	RI	Providence County	39.9%
ARSENIC TSP	530330024	Urban	WA	King County	99.6%
ARSENIC TSP	261630001	Urban	MI	Wayne County	83.8%
ARSENIC TSP	261630019	Urban	MI	Wayne County	78.2%
ARSENIC TSP	261630033	Urban	MI	Wayne County	74.3%
ARSENIC TSP	530330010	Urban	WA	King County	72.1%
ARSENIC TSP	261630005	Urban	MI	Wayne County	68.4%
ARSENIC TSP	530330038	Urban	WA	King County	67.2%
ARSENIC TSP	530330020	Urban	WA	King County	64.0%
ARSENIC TSP	261630027	Urban	MI	Wayne County	64.0%
ARSENIC TSP	261630015	Urban	MI	Wayne County	61.1%
ARSENIC TSP	121035002	Urban	FL	Pinellas County	47.3%
ARSENIC TSP	120571075	Urban	FL	Hillsborough County	44.3%

Table A-2. Population CV estimates by pollutant and site (Cont'd.)

Pollutant	SITE ID	Urban / Rural	State	County	Population CV
ARSENIC TSP	120570081	Urban	FL	Hillsborough County	27.9%
ARSENIC TSP	121031008	Urban	FL	Pinellas County	27.2%
ARSENIC TSP	121030018	Urban	FL	Pinellas County	26.5%
ARSENIC TSP	120571065	Urban	FL	Hillsborough County	22.7%
ARSENIC TSP	080770016	Rural	CO	Mesa County	56.4%
ARSENIC TSP	080770013	Rural	CO	Mesa County	37.0%
BENZENE	261630027	Urban	MI	Wayne County	221.2%
BENZENE	530330032	Urban	WA	King County	93.5%
BENZENE	530330020	Urban	WA	King County	82.2%
BENZENE	530330010	Urban	WA	King County	66.2%
BENZENE	530330024	Urban	WA	King County	64.7%
BENZENE	261630005	Urban	MI	Wayne County	55.1%
BENZENE	121031008	Urban	FL	Pinellas County	49.8%
BENZENE	121030018	Urban	FL	Pinellas County	49.6%
BENZENE	261250010	Urban	MI	Oakland County	48.7%
BENZENE	261630033	Urban	MI	Wayne County	46.2%
BENZENE	440071010	Urban	RI	Providence County	45.8%
BENZENE	121035002	Urban	FL	Pinellas County	41.9%
BENZENE	440070024	Urban	RI	Providence County	41.6%
BENZENE	120571075	Urban	FL	Hillsborough County	41.6%
BENZENE	530330080	Urban	WA	King County	40.1%
BENZENE	530330038	Urban	WA	King County	39.4%
BENZENE	440070025	Urban	RI	Providence County	37.7%
BENZENE	120571065	Urban	FL	Hillsborough County	36.1%
BENZENE	120570081	Urban	FL	Hillsborough County	35.8%
BENZENE	440030002	Urban	RI	Kent County	34.6%
BENZENE	440070022	Urban	RI	Providence County	33.9%
BENZENE	440070026	Urban	RI	Providence County	29.1%
BENZENE	131130037	Rural	GA	Fayette County	54.2%
BENZENE	060653011	Rural	CA	Riverside County	53.7%
BENZENE	131130039	Rural	GA	Fayette County	52.1%
BENZENE	060653012	Rural	CA	Riverside County	49.1%
BENZENE	080770016	Rural	CO	Mesa County	45.8%
BENZENE	080770013	Rural	CO	Mesa County	32.2%
CHROMIUM TSP	530330010	Urban	WA	King County	98.5%
CHROMIUM TSP	530330020	Urban	WA	King County	87.0%
CHROMIUM TSP	530330038	Urban	WA	King County	84.9%
CHROMIUM TSP	530330024	Urban	WA	King County	84.6%
CHROMIUM TSP	121035002	Urban	FL	Pinellas County	61.5%
CHROMIUM TSP	120571065	Urban	FL	Hillsborough County	51.2%
CHROMIUM TSP	120571075	Urban	FL	Hillsborough County	44.6%
CHROMIUM TSP	261630033	Urban	MI	Wayne County	43.9%
CHROMIUM TSP	261630019	Urban	MI	Wayne County	42.7%
CHROMIUM TSP	261630005	Urban	MI	Wayne County	42.0%

Table A-2. Population CV estimates by pollutant and site (Cont'd.)

Pollutant	SITE_ID	Urban / Rural	State	County	Population CV
CHROMIUM TSP	261630015	Urban	MI	Wayne County	39.8%
CHROMIUM TSP	121031008	Urban	FL	Pinellas County	39.5%
CHROMIUM TSP	121030018	Urban	FL	Pinellas County	35.6%
CHROMIUM TSP	120570081	Urban	FL	Hillsborough County	34.5%
CHROMIUM TSP	261630027	Urban	MI	Wayne County	33.0%
CHROMIUM TSP	261630001	Urban	MI	Wayne County	31.8%
FORMALDEHYDE	121031008	Urban	FL	Pinellas County	84.9%
FORMALDEHYDE	120570081	Urban	FL	Hillsborough County	80.1%
FORMALDEHYDE	261630033	Urban	MI	Wayne County	78.0%
FORMALDEHYDE	530330032	Urban	WA	King County	72.2%
FORMALDEHYDE	530330024	Urban	WA	King County	59.7%
FORMALDEHYDE	530330020	Urban	WA	King County	57.9%
FORMALDEHYDE	120571075	Urban	FL	Hillsborough County	55.8%
FORMALDEHYDE	530330010	Urban	WA	King County	53.9%
FORMALDEHYDE	440070024	Urban	RI	Providence County	52.3%
FORMALDEHYDE	530330080	Urban	WA	King County	52.2%
FORMALDEHYDE	261630019	Urban	MI	Wayne County	52.0%
FORMALDEHYDE	530330038	Urban	WA	King County	48.9%
FORMALDEHYDE	261630001	Urban	MI	Wayne County	44.0%
FORMALDEHYDE	121035002	Urban	FL	Pinellas County	40.9%
FORMALDEHYDE	120571065	Urban	FL	Hillsborough County	38.2%
FORMALDEHYDE	440070022	Urban	RI	Providence County	37.4%
FORMALDEHYDE	261630027	Urban	MI	Wayne County	35.8%
FORMALDEHYDE	121030018	Urban	FL	Pinellas County	32.7%
FORMALDEHYDE	261250010	Urban	MI	Oakland County	31.1%
FORMALDEHYDE	440070026	Urban	RI	Providence County	28.3%
FORMALDEHYDE	440071010	Urban	RI	Providence County	26.6%
FORMALDEHYDE	440070025	Urban	RI	Providence County	26.6%
FORMALDEHYDE	060653011	Rural	CA	Riverside County	84.3%
FORMALDEHYDE	131130037	Rural	GA	Fayette County	57.2%
FORMALDEHYDE	060653012	Rural	CA	Riverside County	39.3%
FORMALDEHYDE	131130039	Rural	GA	Fayette County	35.1%
FORMALDEHYDE	080770013	Rural	CO	Mesa County	27.6%
FORMALDEHYDE	080770016	Rural	CO	Mesa County	23.7%

APPENDIX B

NATTS AQS REPORTING GUIDANCE FOR
QUALITY ASSURANCE SAMPLES

BLANKS AND PRECISION SAMPLES
(COLLOCATED, DUPLICATE, AND REPLICATE REPORTING)

Collocated Samples

Collocated samples are samples collected simultaneously at the same location using two completely separate sampling systems, each with a separate inlet probe to the ambient sampled atmosphere. The allowable distance between inlet probes is defined in regulations or in program guidance. Both of the monitors (each designated by a separate AQS Parameter Occurrence Code - POCs) have been established in AQS already. The samples are collected and analyzed separately. Each is reported as a sample value for the appropriate monitor.

Schematic

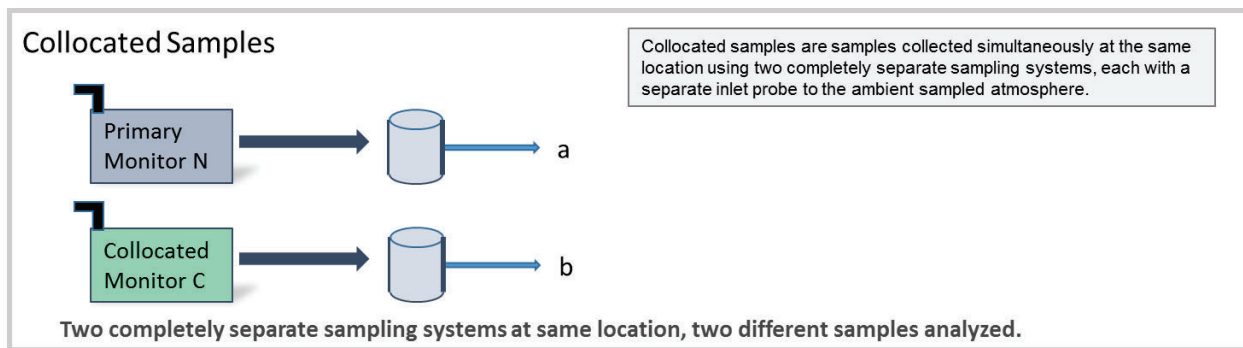

Collocated Sample Reporting Instructions

For AQS to automatically create the 'precision pair' for the primary and collocated samples, the monitors must be identified to the system as QA collocated. One monitor must be designated as the QA primary. If using transactions, the Monitor Collocation Period (MJ) transaction is used. (If using the AQS application, the "QA Collocation" tab on the Maintain Monitor form may be used to enter this data). The collocation data must be entered for **both** monitors, with one indicated as the primary, and the other indicated as the collocated (not the primary). In the example below, the primary monitor is indicated by the bolded 'Y' (yes, this is the primary) in the Primary Sampler Indicator in the first MJ string and the collocated monitor by the bolded 'N' (no, this is not the primary) in the Primary Sampler Indicator in the second MJ string.

Once the monitors have been identified as collocated this is done, there are no additional reporting requirements; simply report the raw data from each monitor (From the schematic, value 'a' from the primary monitor 'N' and value 'b' from the collocated monitor 'C'). Once this is done, AQS will know to pair data from these two monitors for the date range specified.

A set of transactions must be created for each time period the monitors are operating together. The transactions have a begin date and end date for the operational period. The end date may be left blank if the collocation period is still active (as indicated in the example below). To define a collocation, submit two MJ transactions (example below with differences bolded and where primary monitor 'N' is POC 5 and collocated monitor 'C' is POC 9):

```
MJ|I|11|222|3333|44444|5|20150101||3|Y
MJ|I|11|222|3333|44444|9|20150101||3|N
```

Report two Raw Data (RD) transactions for each time sample data are to be reported from both monitors; one for each monitor (POC). (In this example, sample ‘a’ is 0.0463 from monitor ‘N’ (POC 5) and sample ‘b’ from monitor ‘C’ (POC 9) is 0.0458):

```
RD|I|11|222|3333|44444|5|7|454|888|20150101|00:00|0.0463||6|||||||0.0001|0.0005
RD|I|11|222|3333|44444|9|7|454|888|20150101|00:00|0.0458||6|||||||0.0001|0.0005
```

Since there are two monitors involved, each sample is reported for its appropriate POC and there will be an RD transaction for every time there is a valid sample from each monitor (e.g., two per day in this scenario). If the sample value from one POC is not available, report a null data code for that monitor (that is, do not report the sample value from the collocated monitor as being from the primary POC).

Duplicate Samples

Duplicate samples are two (or more) samples collected simultaneously using one or more sampling units sharing a common inlet probe to the ambient atmosphere and the collected samples are analyzed separately. This simultaneous collection may be accomplished by “teeing” the line from the flow control device (sampling unit) to the media (e.g. canisters), and then doubling the collection flow rate, or may be accomplished by collecting one discrete sample via two separate flow control devices (sampling units) connected to the same inlet probe.

Schematic

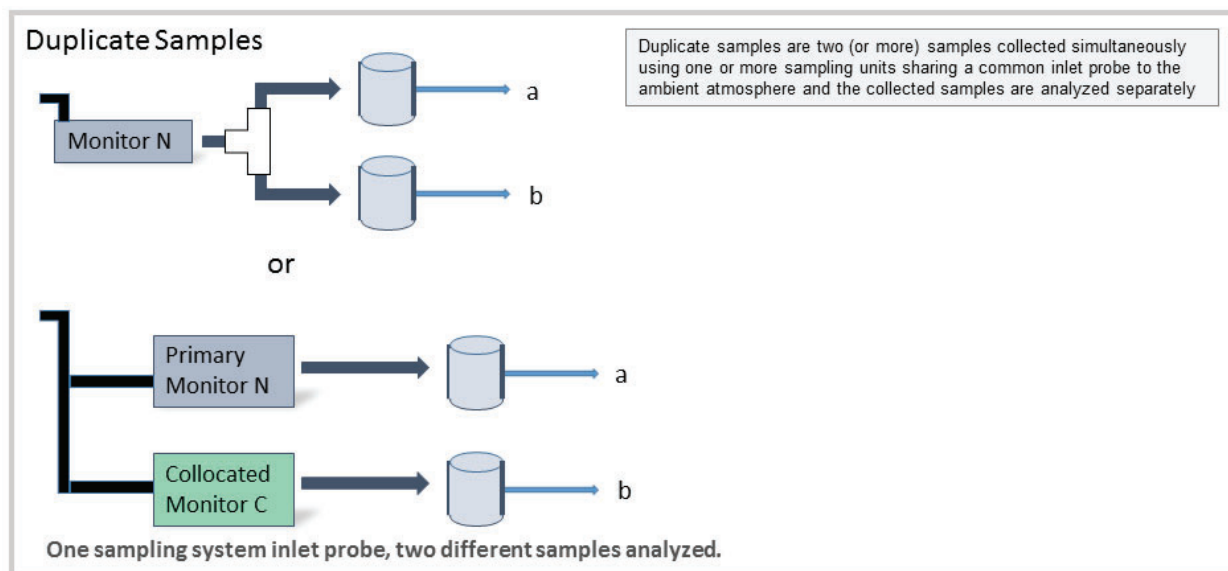

Duplicate Sample Reporting Instructions

In this case, there is only one inlet probe involved but with multiple samples. Since only one inlet probe is involved, all data should be reported for the same POC.

First, report the raw data as you normally would via the RD transaction. Report just one value, the one for the sample obtained through the ‘primary’ hardware (the normal flow path or normal canister, etc. as defined by the monitoring organization convention – typically this would be sample ‘a’). In this case, if sample ‘a’ comes from the primary hardware and has a value of 54.956, you would report:

```
RD|I|11|222|3333|44444|5|7|454|888|20150101|00:00|54.956||6|||||||0.0001|0.0005
```

If the primary value is null for some reason, the duplicate value may be reported as the sample value for this POC in the RD transaction. In this case, there is not a valid duplicate assessment to report. If all duplicates are null, an RD transaction with no sample value and a null data code should be reported.

Each of the duplicate sample values is then also reported via the QA – Duplicate transaction. This transaction has room for up to 5 duplicate sample values. Report them in any order, starting with 1 and proceeding through the number of samples. In the schematic, there are two samples (a ‘primary’ and a ‘duplicate’) so sample value ‘a’ would be reported as Duplicate Value 1 and sample value ‘b’ would be reported as Duplicate Value 2. The same value reported on the Raw Data transaction must be one of the values reported on the QA – Duplicate transaction.

Note that there is no sampling time reported on the QA – Duplicate transaction. Instead, there is an Assessment Date and an Assessment Number. If multiple duplicate samples are performed on the same day, label the first with Assessment Number = 1, the second with Assessment Number = 2, and so on. Also note that all values must be reported in the same units of measure.

Here is an example QA – Duplicate transaction (with sample ‘a’ = 54.956 and sample ‘b’ = 51.443 – Assessment Number ‘1’ bolded):

```
QA|I|Duplicate|999|11|222|3333|44444|5|20150101|1|454|888|54.956|51.443|
```

Assessment Number = 2, and so on. Also note that all values must be reported in the same units of measure.

Here is a sample QA – Replicate transaction (if sample values ‘a’, ‘b’, and ‘c’ are 0.844, 0.843, and 0.792, respectively):

QA|I|Replicate|999|11|222|333|44444|5|20210101|1|454|888|0.844|0.843|0.792|||

Combining Duplicates and Replicate Analysis

It is possible to collect duplicate samples simultaneously and perform replicate analyses of these duplicate samples. This is often referred to as a duplicate/replicate sample. In this case (see schematic below), there are two duplicate samples, ‘1’ and ‘2’. Duplicate Sample ‘1’ has three replicates: ‘a’, ‘b’, and ‘c’. Duplicate Sample ‘2’ has three replicates: ‘d’, ‘e’, and ‘f’.

Schematic

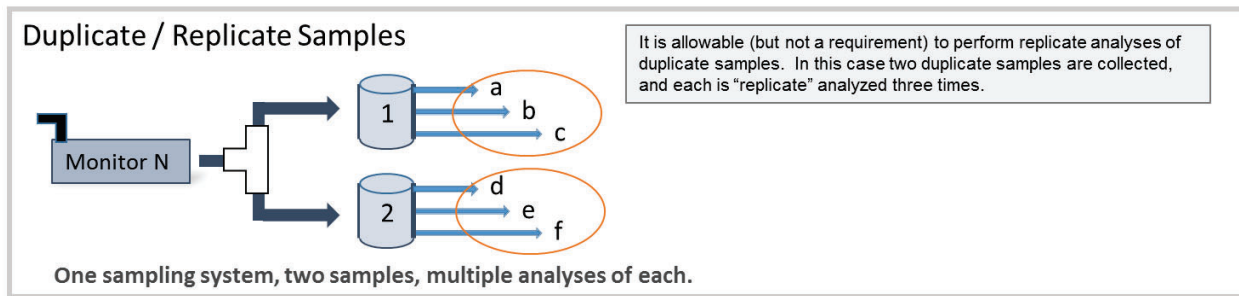

Duplicate/Replicate Reporting Instructions

This scenario requires the reporting of an RD transaction, a QA – Duplicate transaction, and a QA – Replicate transaction to AQS.

For the RD transaction, follow the same rules to report the value from the primary (normal) hardware (this would typically be sample ‘1’, replicate ‘a’) and operations procedure path if possible; follow the convention established by the laboratory. If the normal hardware path yields sample ‘1a’ you would report (in this case the value is represented by the “a” in the appropriate place, with spaces for clarity):

RD|I|11|222|3333|44444|5|7|454|888|20150101|00:00| a ||6| ||||| ||0.0001|0.0005

For the QA - Duplicate transaction: select one of the replicate analyses each from the primary and duplicate sample (using the convention established by the laboratory) and report those on the QA – Duplicate transaction. If the values to be reported are ‘1a’ and ‘2d’, the record would look like this (again, values are represented by ‘a’ and ‘d’, spaces added for clarity):

QA|I|Duplicate|999|11|222|333|44444|5|20210101|1|454|888| a | d | | | |

There are only two duplicate samples (one pair) in this case because only two paths were assessed. (That is, you are not allowed to cross-multiply the replicate analyses to create additional duplicate assessments [pairs].)

For the replicate transaction: report this as two assessments. Assessment Number 1 for the day would include the values for replicates ‘a’, ‘b’, and ‘c’. Assessment Number 2 for the day would include values for replicates ‘d’, ‘e’, and ‘f’.

The example transactions, using letters in place of the values:

QA|I|Replicate|999|11|222|333|44444|5|20210101|1|454|888| a | b | c | | |
QA|I|Replicate|999|11|222|333|44444|5|20210101|2|454|888| d | e | f | | |

Combining Collocated Samples and Replicate Analysis

It is also possible to make replicate analyses of collocated samples. These is is are sometimes referred to as collocated replicate samples.

Schematic

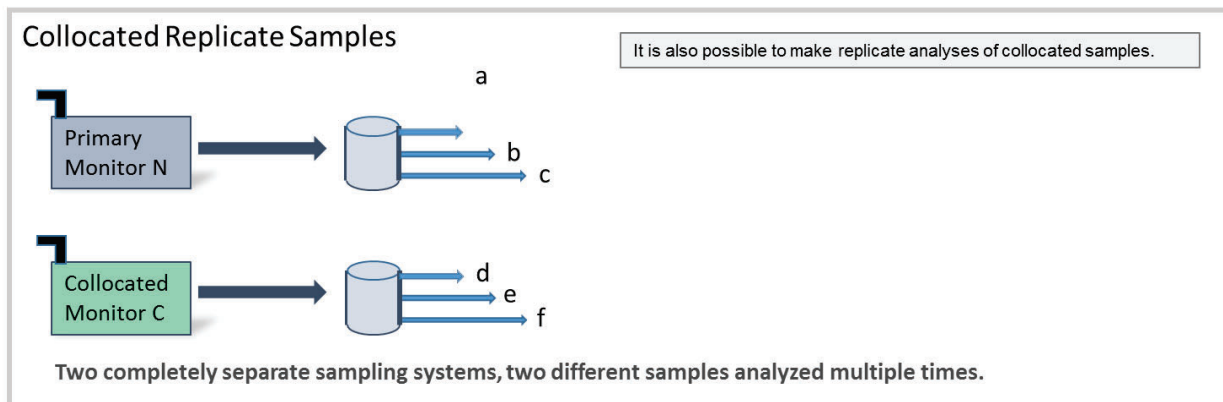

Collocated Replicate Reporting Instructions

Since collocated monitors report all data independently, report these data for each monitor (e.g., under its own POC) according to the replicate reporting instructions.

APPENDIX C
EPA ROUNDING GUIDANCE
Provided by EPA Region IV

Rounding Policy for Evaluating NAAQS QA/QC Acceptance Criteria

The following outlines EPA's Rounding Policy for evaluating Quality Assurance / Quality Control (QA/QC) acceptance criteria. This policy is being provided to air monitoring organizations in order to ensure consistency across the country in the validation of monitoring data that is used for demonstrating compliance with the National Ambient Air Quality Standards (NAAQS).

EPA's interpretation of standard rounding conventions is that the resolution of the measurement device or instrument determines the significant figures used for rounding. The acceptance criteria promulgated in the appendices of 40 CFR Part 50, or otherwise established in EPA guidance documents, are not physical measurements. As an example, the quality control (QC) acceptance criterion of $\pm 5\%$ stated in the fine particulate matter regulations (40 CFR Part 50, Appendix L, Section 7.4.3.1) is not a measurement and, as such, does not directly contribute to either the significant figures or to rounding. However, the flow rate of the sampler – measured either internally by the flow rate control system or externally with a flow rate audit standard – is a measurement, and as such, will contribute to the significant figures and rounding. EPA's position is that it is not acceptable to adjust or modify acceptance criteria through rounding or other means.

Example using PM_{2.5} Sampler Design Flow Rate

40 CFR Part 50, Appendix L, Section 7.4.3.1 defines the 24-hour sample flow rate acceptance criterion as $\pm 5\%$ of the design flow rate of the sampler (16.67 liters per minute, LPM). The QC acceptance criterion of $\pm 5\%$ stated in regulation is not a measurement and, therefore, does not contribute towards significant figures or rounding. The measurement in this example is the flow rate of the sampler. PM_{2.5} samplers display flow rate measurements to the hundredths place (resolution) – e.g., 16.67 LPM, which has 4 significant figures. Multiplying the design flow rate (16.67 LPM) by the $\pm 5\%$ acceptance criterion defines the acceptable flow regime for the sampler. By maintaining 4 significant figures – with values greater than 5 rounding up – the computations provide the following results:

- The low range is -5% of the design flow: $0.95 \times 16.67 = 15.8365 \approx 15.84$
- The upper range is +5% of the design flow: $1.05 \times 16.67 = 17.5035 \approx 17.50$

Rounding in this manner, the lower and upper acceptance limits for the flow rate measurement are defined as 15.84 and 17.50 LPM, respectively.

40 CFR Part 58, Appendix A, Section 3.2.1 requires monthly PM_{2.5} flow rate verifications. The verification is completed with an independent audit standard (flow device). The monthly check includes a calculation to ensure the flow rate falls within $\pm 5\%$ of the design flow rate (see

Method 2.12, Section 7.4.7). Therefore, flow rates obtained during monthly flow rate verification checks should measure between 15.84 – 17.50 LPM, as defined above.

Measurements, in general, are approximate numbers and contain some degree of error at the outset; therefore, care must be taken to avoid introducing additional error into the final results. With regards to the PM_{2.5} sampler's design flow rate, it is not acceptable to round the ±5% acceptance criterion such that any calculated percent difference up to ±5.4% is acceptable – because rounding the acceptance criterion increases the error in the measurement. It is important to note that the PM_{2.5} sampler must maintain a volumetric flow rate of approximately 16.67 LPM in order for its inertial separators to appropriately fractionate the collected ambient air particles. Flow rates greater than 5% of the nominal 16.67 LPM will shift the cut point of the inertial separator lower than the required aerodynamic diameter of 2.5 microns and, thus, block the larger fraction of the PM_{2.5} sample from being collected on the sample filter. Conversely, as the sampler's flow rate drops below -5% of the nominal 16.67 LPM, the inertial separator will allow particulate matter with aerodynamic diameters unacceptably larger than 2.5 microns to be passed to the sample filter. Therefore, it is imperative that the flow rate of the sampler fall within the ±5% acceptance criterion.

A Note on Resolution and Rounding

Measurement devices will display their measurements to varying degrees of resolution. For example, some flow rate devices may show measurements to tenths place resolution, whereas others may show measurements to the hundredths place. The same holds true for thermometers, barometers, and other instruments. With this in mind, rounding should be based on the measurement having the least number of significant figures. For example, if a low-volume PM₁₀ sampler displays flow rate measurements to the tenths place (3 significant figures), but is audited with a flow device that displays measurements to the hundredths place (4 significant figures), the rounding in this scenario will be kept to 3 significant figures.

Table 1 below lists some examples of NAAQS regulatory QA/QC acceptance criteria with EPA's interpretation of the allowable acceptance ranges, as well as a column that identifies results that **exceed** the stated acceptance limits. Table 1 is not a comprehensive list of ambient air monitoring QA/QC acceptance criteria. Rather, Table 1 is provided to demonstrate how EPA evaluates acceptance criteria with respect to measurement resolution.

The validation templates in the QA Handbook Vol II will be revised to meet this policy.

If you have any questions regarding this policy or the rounding conventions described, please contact your EPA Regional Office for assistance.

Table 1: Examples of Quality Control Acceptance Criteria

Regulatory Method Requirement	Method Acceptance Criteria	Typical Measurement Resolution	Acceptance Range (Passing Results)			Exceeding QA/QC Check
Shelter Temperature	20 to 30°C or FEM op. range	1 Decimal, 3 SF*	20.0 to 30.0°C or FEM op. range			≤ 19.9°C ≥ 30.1°C
PM2.5 Design Flow (16.67 lpm)	±5%	2 Decimal, 4 SF	15.84 to 17.50 lpm			≤ -5.1% ≥ +5.1%
PM2.5 Transfer Standard Tolerance	±4%	2 Decimal, 4 SF	-4% Audit Std	Sampler Display	+4% Audit Std	≤ -4.1% ≥ +4.1%
				15.84	16.47	
			16.00	16.67	17.34	
			16.80	17.50		
PM2.5 Lab: Mean Temp 24-hr Mean	20 to 23°C	1 Decimal, 3 SF	20.0 to 23.0°C			≤ 19.9°C ≥ 23.1°C
PM2.5 Lab: Temp Control SD over 24-hr	±2°C	1 Decimal, 3 SF	±2.0°C			≤ -2.1°C ≥ +2.1°C
PM2.5 Lab: Mean RH 24-hr Mean	30% to 40%	1 Decimal, 3 SF	30.0% to 40.0%			≤ 29.9% ≥ 40.1%
PM2.5 Lab: RH Control SD over 24-hr	±5%	1 Decimal, 3 SF	±5.0%			≤ -5.1% ≥ +5.1%
PM2.5 Lab: Difference in 24-hr RH Means	±5%	1 Decimal, 3 SF	±5.0%			≤ -5.1% ≥ +5.1%

*SF = Significant Figures

APPENDIX E. Standard Operating Procedure
for Collection of VOC Samples (R5-ARD-0003-
r2)

Document No.: R5-ARD-0003-r2

Title: VOC Sampling

Effective Date: 09/29/2017



**U.S. Environmental Protection Agency, Region 5
Field Quality Procedures**

**TECHNICAL FIELD
STANDARD OPERATING PROCEDURE**

Standard Operating Procedure for collection of VOC samples

Effective Date	Number
9/29/2017	R5-ARD-0003-r2

Author

Name: Scott Hamilton

Title: Author

Signature: 

Date: 9/20/17

Review & Approvals

Name: Jackie Nwia

Title: Reviewer

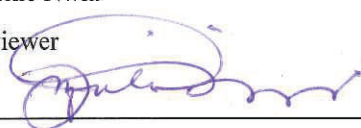
Signature: 

Date: 9/20/17

Name: Bilal Qazzaz

Title: Quality Assurance Coordinator

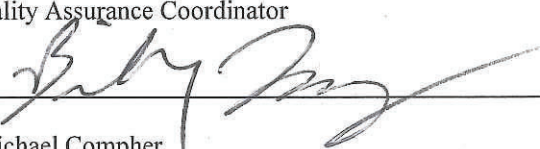
Signature: 

Date: 9/21/17

Name: Michael Compher

Title: Air Monitoring and Analysis Section Chief

Signature: 

Date: 9/28/17

Document No.: R5-ARD-0003-r2

Title: VOC Sampling

Effective Date: 09/29/2017

REVISION/CHANGE HISTORY

The table below identifies changes to this controlled document and the respective effective date(s) over time.

Revision Number	History/Change Description	Document Author/Owner	Management Approver	Effective Date
0	Original Document	Chad McEvoy	Michael Compher	03-31-2015
1	Updated to include Canister Sampling Field Test Data Sheet, more specific instructions for conducting the sample collection, and other minor edits	Jacqueline Nwia	Michael Compher	05-03-2017
2	Added language on evidence tampering and deleted option to ship samples.	Scott Hamilton	Michael Compher	9-29-2017

Document No.: R5-ARD-0003-r2
Title: VOC Sampling
Effective Date: 09/29/2017

TABLE OF CONTENTS

1.0 PURPOSE.....4

2.0 APPLICABILITY/SCOPE.....4

3.0 DEFINITIONS.....4

4.0 SUMMARY OF METHOD/PROCEDURE.....4

5.0 PERSONNEL QUALIFICATIONS/RESPONSIBILITIES.....5

6.0 EQUIPMENT AND SUPPLIES.....5

7.0 REAGENTS AND STANDARDS.....5

8.0 HEALTH AND SAFETY CONSIDERATIONS.....6

9.0 INTERFERENCES.....6

10.0 PROCEDURE.....6

11.0 WASTE MANAGEMENT.....10

12.0 DATA AND RECORDS MANAGEMENT.....10

13.0 QUALITY CONTROL & QUALITY ASSURANCE.....11

14.0 REFERENCES.....11

15.0 ATTACHMENTS.....11

Document No.: R5-ARD-0003-r2

Title: VOC Sampling

Effective Date: 09/29/2017

1.0 PURPOSE

1.1 This standard operating procedure describes steps for collecting air samples in the field for later analysis at Region 5 Chicago Regional Laboratory (CRL). This SOP is intended for use by field technicians so samples are collected consistently and documented properly.

2.0 APPLICABILITY/SCOPE

2.1 This document applies to the collection of air samples in the field. Field technicians should follow this SOP to ensure samples are collected properly and consistently, and that all documentation is completed.

2.2 The official signed copy of this SOP will be stored in the QA Tracking system under the folder "VOC SOP" and will be available to all field sampling staff. The SOP should be reviewed annually.

2.3 This document outlines obtaining the sampling vessels (i.e. bottles or canisters) from CRL, collecting and documenting the sample in the field, completing the chain-of-custody, and returning the samples to CRL.

2.4 This SOP is written to provide general instruction for collecting samples; individual projects will have specific needs and processes. Refer to the project specific Quality Assurance Project Plan (QAPP) or sampling plan for details.

3.0 DEFINITIONS

COC	Chain of Custody
CRL	Chicago Regional Laboratory
GMAP	Geospatial Monitoring of Air Pollutants
PID	Photo Ionization Detector
QAPP	Quality Assurance Project Plan
VOC	Volatile Organic Compounds

4.0 SUMMARY OF METHOD/PROCEDURE

4.1 Field staff will use containers supplied by CRL to collect air samples by opening the

Document No.: R5-ARD-0003-r2

Title: VOC Sampling

Effective Date: 09/29/2017

valve on the canister, allowing the sample to enter the canister or bottle and then closing the valve. Samples may be grab samples or composite samples collected over a period of time. Staff will document relevant information on the sample labels (supplied by CRL), Canister Sampling Field Test Data Sheet (from Compendium Method TO-15) and chain of custody form (supplied by CRL). Labelled samples, Field Test Data Sheet and the chain of custody form(s) are then returned to CRL's sample custodian. Results will be reported by CRL at a future date.

5.0 PERSONNEL QUALIFICATION/RESPONSIBILITIES

5.1 Personnel involved in the collection of samples must meet the minimum training requirements for safety and technical expertise. Minimum training will include a background in air programs and hands on training with CRL or air monitoring personnel. The field staff is also responsible for reviewing this SOP prior to conducting sampling using passive canisters. Approved copies of this SOP and the project-specific air monitoring Quality Assurance Project Plan (QAPP) will be available to field staff throughout the duration of sampling activities.

6.0 EQUIPMENT AND SUPPLIES

6.1 Equipment used for the collection of VOC samples will vary depending on the objective of the project and the compounds of interest. Metal canisters or glass bottles could be used to hold the sample, and different volumes of containers are available. Both factors are dictated by the compounds of interest, project goals, and resource availability. Regulators/orifices (obtained from CRL and provided with the vessels) may be attached to the vessels to restrict the flow, allowing for a longer and/or specific sampling time.

6.2 Sample labels and chain of custody form will be supplied by CRL to document sample information.

7.0 REAGENTS AND STANDARDS

7.1 No reagents or standards are used during sample collection.

7.2 All reagents and standards used as part of the laboratory analysis can be found in section 7 (Reagents & Standard Gas Mixtures) of the Central Regional Laboratory's "SOP for VOCs in Air from TO-15" CRL SOP MS-005 Revision 6, Dated 06/04/2013.

Document No.: R5-ARD-0003-r2

Title: VOC Sampling

Effective Date: 09/29/2017

8.0 HEALTH AND SAFETY CONSIDERATIONS

8.1 Field staff must complete the minimum safety training as required by the USEPA. Minimum safety trainings include the USEPA 24-hour field safety course and annual 8 hour refresher courses as required. Any necessary health and safety equipment needs for specific projects must be made in coordination with the Regional Safety Manager.

9.0 INTERFERENCES

9.1 The possibility of contamination of canister samples exists due to the improper handling and wear of canister valves.

9.2 Special attention must be given to canisters with QT valves; QT valves are normally in a closed position to minimize leakage, a protective cover should be placed over the valve to minimize leakage and prevent contamination of the canister. Bottles with QT valves should be evacuated using a dual stage pump in the field on the day of sampling, or as close to the day of sampling as possible. The dual stage pump should be capable of creating a strong vacuum within the bottle.

9.3 Additional possibilities of laboratory and storage contamination and preventative procedures can be found in section 5 (Caution & Interferences) of the Central Regional Laboratory's "SOP for VOCs in Air from TO-15" CRL SOP MS-005 Revision 6, Dated 06/04/2013.

10.0 PROCEDURE

10.1 Instrument or Method Calibration and Standardization

1. No instrument or method calibrations are expected for sample collection.
2. Steps should be taken to standardize sample collection as much as possible. Field technicians should consider the following:
 - a) Avoid wearing perfumes, lotions, or hand sanitizers prior to or during sample collection.
 - b) Record data (GPS values, time, etc) from the same source each time.
 - c) If taking grab samples, hold away from the body.
 - d) Note any nearby activity that may influence the sample on the sample label and in field notes.

Document No.: R5-ARD-0003-r2

Title: VOC Sampling

Effective Date: 09/29/2017

- e) An upwind or background sample may be helpful; refer to the project QAPP or sampling plan.
- f) Copy or photograph sample labels and the completed chain of custody form.

10.2 General field or equipment procedures

1. Field staff must request VOC sample bottles or canisters from CRL's sample coordinator (Amanda Wroble) by completing "CRL Form 008 Rev 1.1- November 2013". CRL chemists are available to discuss, and recommend, possible lab analyses. The lab may need some time to ensure sufficient, appropriate sample containers are available, and may need time to prepare the analysis equipment. Field staff should also be familiar with the sample return process in order to efficiently return the samples to the sample custodian (Rob Snyder 312-353-9083). Information on shipping samples are available on CRL Form 008 Rev 1.1- November 2013.
2. Field personnel that collect potential evidence for enforcement purposes, must follow established procedures or guidance to document and demonstrate custody and integrity of the sample of the samples.
3. Field samples and appropriate environmental data shall be maintained under custody at all times during field activities. Samples and data are in custody if they are:
 - a. Within the direct possession or the control (i.e. within the view) of an individual designated to have sample handling responsibilities; or
 - b. Placed in a designated area to prevent tampering; or
 - c. Maintained in a manner that ensures the integrity of the samples is not compromised when placed in an unsecured area.

10.3 Sample Collection

- a. Grab sample Procedure:
 1. Choose canister and gather COC and canister sticker (if applicable).
 2. Record all information on the sample label provided by CRL and place the label on the canister.
 3. Record all information on the COC as follows. If errors are made on the form strike through with one line, initial and date the error. Then write the correct information on the form. A sample COC form is in Appendix C. It is acceptable to use two lines for one canister to record information if needed. Be sure to draw a full line through the row in the areas where additional space was not needed.
 - a. PROJECT NAME = Project name should be a unique name for you to identify this group of samples.
 - b. SAMPLER NAME = Write the samplers name and signature.

Document No.: R5-ARD-0003-r2

Title: VOC Sampling

Effective Date: 09/29/2017

- c. STA. NO. = Station Number. For the first canister write "1" for the second canister write "2", etc.
 - d. DATE = write the date.
 - e. TIME = write the time the sample was taken. This should be filled out last since it will take some time to complete all paperwork before the sample is actually taken.
 - f. COMP/GRAB = "Composite or Grab Sample". Check the box under Grab sample.
 - g. STATION LOCATION = Write the GPS coordinates of where the sample was taken.
 - h. NO. OF CONTAINERS = "1"
4. Remove the ¼ inch cap from the inlet of the canister.
 5. Hold the canister out away from the sampler's body facing the direction where the air is coming from and in the direction of the air you want to sample. Hold the canister as far as possible with the inlet facing away from you, above your head, if possible.
 6. Open the canister valve (righty-tighty, lefty loosey). The sampler should hear a distinct hiss for 5-10 seconds. This sound is the sample canister filling up with sample air.
 7. Leave the valve open until the hissing stops and then close the valve tightly. Replace the ¼ inch cap and tighten.
 8. Record the sample time on the COC.
 9. Place the canister back in the box and store it in a safe spot under lock and key. Sample should be delivered to CRL as soon as possible. Ensure that the sampler signs and dates the COC under "relinquished by" and that the sample custodian signs and dates the COC under "received by". The pink copy should be given to the sampler.
 10. Additional notes may be helpful such as pressure, temperature, other meteorological conditions and distinct odors.
- b. Composite sample Procedure:
1. Choose canister and gather COC, canister sticker (if applicable) and field data form.
 2. Record all information on the sample label provided by CRL and place the label on the canister.
 3. Record all information on the COC as follows. If errors are made on the form strike through with one line, initial and date the error. Then write the correct information on the form. A sample COC form is in Appendix C. It is acceptable to use two lines for one sample to record information if needed. Be sure to draw a full line through the row in the areas where additional space was not needed.

Document No.: R5-ARD-0003-r2

Title: VOC Sampling

Effective Date: 09/29/2017

- a. PROJECT NAME = Project name should be a unique name for you to identify this group of samples.
 - b. SAMPLER NAME = Write the samplers name and signature. Each sampler must utilize their own COC.
 - c. STA. NO. = Station Number. For the first canister write "1" for the second canister write "2", etc.
 - d. DATE = write the date.
 - e. TIME = write the time the sample begins.
 - f. COMP/GRAB = "Composite or Grab Sample". Check the box under Composite sample.
 - g. STATION LOCATION = Write the GPS coordinates of where the sample was taken.
 - h. NO. OF CONTAINERS = "1"
4. Remove the ¼ inch cap from the inlet of the canister.
 5. Install the sample inlet assembly and tighten snugly with a 9/16" wrench.
 6. Place the canister in the desired sampling position.
 7. Record the following information on the Canister Sampling Field Test Data Sheet (Appendix D). Note that not all information requested on the general TO-15 form is needed.
 - a. Site Location
 - b. Sampling Date
 - c. Canister SN
 - d. Operator
 - e. Temperature Start Ambient
 - f. Canister Pressure start
 - g. Local Time start
 - h. Leave all of Section C blank
 8. Open the canister valve (righty-tighty, lefty loosey).
 9. The canister is now filling. It is a good idea to return to the station in a few hours to observe the pressure. It is imperative that the canister still be under slight vacuum at the conclusion of the sampling time.
 10. At the conclusion of the sampling time close the valve tightly, remove the sample inlet assemble and replace the ¼ inch cap and tighten.
 11. Record the following information on the Canister Sampling Field Test Data Sheet (Appendix D). Note that not all information requested on the general TO-15 form is needed.
 - a. Temperature End Ambient
 - b. Canister Pressure End
 - c. Local Time Stop
 - d. Leave all of Section C blank

Document No.: R5-ARD-0003-r2

Title: VOC Sampling

Effective Date: 09/29/2017

12. Place the canister back in the box and store it in a safe spot under lock and key. Sample should be delivered to CRL as soon as possible. Ensure that the sampler signs and dates the COC under “relinquished by” and that the sample custodian signs and dates the COC under “received by”. The pink copy should be given to the sampler.
13. Additional notes may be helpful such as other meteorological conditions and distinct odors.

10.4 Sample Handling and Preservation

1. Samples should be handled gently and packed to prevent breakage. Ensure all information has been recorded on sample labels.
2. Immediately transport samples back to CRL’s sample custodian with completed Canister Sampling Field Test Data Sheet and COC.

10.5 Sample Preparation and Analysis

Samples will not be prepared or analyzed in the field. Samples will be prepared and analyzed by CRL following their procedures in the laboratory.

10.6 Troubleshooting

1. Field technicians should inspect sample vessels before collecting a sample to be sure the vessel hasn’t been compromised prior to use. Do not use any vessel suspected of having a leak prior to sample collection.
2. Technicians may hear a hiss or pop as air rushes into a vessel (especially for a grab sample). No sound may indicate the vessel leaked prior to use.
3. Record all information onto the sample label **at the time of collection**.

10.7 Data Acquisition, Calculations, and Data Reduction

N/A

10.8 Data Review and Acceptance

Ensure all fields on the sample label(s), Canister Sampling Field Test Data Sheet and chain of custody form(s) have been completed.

11.0 WASTE MANAGEMENT

N/A

12.0 DATA AND RECORDS MANAGEMENT

- 12.1 All COC forms and other field notes will be submitted to the project manager and

Document No.: R5-ARD-0003-r2

Title: VOC Sampling

Effective Date: 09/29/2017

will be stored with other data associated with the project (i.e. GMAP data). The CRL will complete analysis of the canisters or bottles as soon as possible after sampling. CRL will submit validated data to the project manager.

13.0 QUALITY CONTROL & QUALITY ASSURANCE

The field staff must note any deviations from the sample plan or procedure on the sample label and field notes. Also note anything unusual or unexpected that may influence the sample results (i.e. markers, vehicle fuels, newly paved roads, nearby non-target activities, etc.).

14.0 REFERENCES

SOP for VOCs in Air from TO-15 CRL SOP MS-005 Revision 6, Dated 06/04/2013

15.0 ATTACHMENTS

APPENDIX A	CRL Form 008 Rev 3- March 2017
APPENDIX B	CRL Sample Label
APPENDIX C	CRL Chain of Custody
APPENDIX D	COMPENDIUM METHOD TO-15 CANISTER SAMPLING FIELD TEST DATA SHEET

Document No.: R5-ARD-0003-r2

Title: VOC Sampling

Effective Date: 09/29/2017

APPENDIX A

CRL Form 008 Rev 3- March 2017



**U.S. ENVIRONMENTAL PROTECTION AGENCY—REGION 5
CHICAGO REGIONAL LABORATORY
ANALYTICAL REQUEST FORM**

This analytical request form should be completed before sending samples to CRL for analysis. The requester should complete all relevant fields and email the form and electronic copy of the quality assurance project plan (QAPP) and/or sampling plan to the CRL Sample Coordinator Rob Thompson (Thompson.robert@epa.gov).

GENERAL PROJECT INFORMATION	
Requester:	Request Date:
Title:	Division/Office:
Address:	
Phone:	E-mail:
<input type="checkbox"/> One-time or <input type="checkbox"/> Continuous request (<i>check one</i>) A continuous request is defined as a standing request for the same analytical service (analyses and sample matrices) that may span several sites/projects/sampling events. Please note that submission of this analytical request form is only required once for a continuous request. However, QAPPs and/or sampling plans should still be submitted for every site/project.	
Site Name and Location:	
Expected Arrival Date at CRL:	
Turnaround Time Requested (<i>standard TAT is 45 days</i>):	

CRL ANALYTICAL SERVICES
<p>Disclaimer:</p> <p>The effective versions of all Standard Operating Procedures (SOPs) are available in pdf format on the R5 Intranet. By submitting an analytical request form, the requestor is implying consent for the use of the appropriate effective SOPs. It is the responsibility of the requester to check the intranet for SOP deviations (known at CRL as Pen&Ink changes) and version updates. Should the CRL suspect that an SOP deviation affect the data, the CRL Sample Coordinator will contact the requester via email or phone to obtain a Pen&Ink consent. As defined by CRL, SOP deviations "affect the data" when there is a change in the laboratory's ability to identify or quantify the analytes in the SOP or when there is a deviation in the regulatory method.</p> <p>Form Instructions:</p> <ol style="list-style-type: none"> In the table below, select the appropriate checkbox to request an analysis and enter the proposed number of samples of each matrix type. An analysis is not currently available for a matrix where the box is shaded. For other/waste, briefly describe the matrix in the space provided. Additional space for a detailed matrix description is available at the end of the table, if needed. For multi-analyte tests, list specific classes/subsets (e.g., PAHs, RCRA metals, etc.) in the space given at the end of this table, if requested.

General Chemistry

Analysis Request		Sample Matrix and Number		
Analysis	Check to Request	soil/sediment	water/liquid	other/waste*
acidity	<input type="checkbox"/>		---	---
alkalinity	<input type="checkbox"/>		---	---
ammonia-N	<input type="checkbox"/>	---	---	---
anions**	<input type="checkbox"/>	---	---	---
biochemical oxygen demand-5 day (BOD)	<input type="checkbox"/>		---	---
carbonaceous BOD-5 day (CBOD)	<input type="checkbox"/>		---	---
corrosivity by pH	<input type="checkbox"/>		---	---
cyanide, amenable to chlorination	<input type="checkbox"/>		---	---
cyanide, total	<input type="checkbox"/>	---	---	---
dissolved organic carbon (DOC)	<input type="checkbox"/>		---	---
fluoride	<input type="checkbox"/>	---	---	---
grain size	<input type="checkbox"/>	---		---
ignitability by flashpoint	<input type="checkbox"/>		---	---
nitrate-nitrite-N	<input type="checkbox"/>		---	---
paint filter liquid test	<input type="checkbox"/>		---	---
pH	<input type="checkbox"/>	---	---	---
residue, filterable (TDS)	<input type="checkbox"/>		---	---
residue, non-filterable (TSS)	<input type="checkbox"/>		---	---
solvent ID	<input type="checkbox"/>		---	---
total Kjeldahl nitrogen (TKN)	<input type="checkbox"/>	---	---	---
total organic carbon (TOC)	<input type="checkbox"/>	---	---	---
total phosphorus (TP)	<input type="checkbox"/>	---	---	---
total dissolved phosphorus (TDP)	<input type="checkbox"/>		---	---
total solids (TS)	<input type="checkbox"/>		---	---
total volatile solids (TVS)	<input type="checkbox"/>		---	---
turbidity	<input type="checkbox"/>		---	---
water content	<input type="checkbox"/>		---	---

Metals

Analysis Request		Sample Matrix and Number		
Analysis	Check to Request	soil/sediment	water/liquid	other/waste*
chromium (VI)	<input type="checkbox"/>	—	—	
dissolved metals** (except Hg & Cr (VI))	<input type="checkbox"/>		—	—
hardness	<input type="checkbox"/>		—	—
mercury (Hg)	<input type="checkbox"/>	—	—	
total metals** (except Hg & Cr (VI))	<input type="checkbox"/>	—	—	— wipe/filter

Organics

Analysis Request		Sample Matrix and Number		
Analysis	Check to Request	soil/sediment	water/liquid	other/waste*
air toxics**	<input type="checkbox"/>			— air
1,4-dioxane, low level	<input type="checkbox"/>		—	—
oil & grease	<input type="checkbox"/>		—	—
polychlorinated biphenyls (PCB) congeners	<input type="checkbox"/>	—		—
perfluorinated compounds** (PFCs)	<input type="checkbox"/>	—	—	—
pesticides, chlorinated**	<input type="checkbox"/>	—	—	—
PCB aroclors**	<input type="checkbox"/>	—	—	—
semi-volatiles** (SVOCs)	<input type="checkbox"/>	—	—	—
total petroleum hydrocarbons (TPH as DRO/ORO)	<input type="checkbox"/>	—	—	—
(tri-n-butyl)-n-tetradecylphosphonium chloride (TTPC)	<input type="checkbox"/>	—	—	—
volatiles** (VOCs)	<input type="checkbox"/>	—	—	—

Toxicity Characteristic Leaching Procedure (TCLP)

Analysis Request		Sample Matrix and Number		
Analysis	Check to Request	soil/sediment	water/liquid	other/waste*
TCLP Hg	<input type="checkbox"/>	—	—	—
TCLP metals	<input type="checkbox"/>	—	—	—
TCLP pesticides	<input type="checkbox"/>	—	—	—
TCLP SVOCs	<input type="checkbox"/>	—	—	—
TCLP VOCs	<input type="checkbox"/>	—	—	—

*Additional Matrix Description

Please describe *other/waste* matrix, if not specified above:

**Specific Analyte Class/Subset Request

Please list or attach specific class/subset for multi-analyte test, if requested:

NON-STANDARD REQUESTS

For analyses/matrices not listed above or to obtain analyte lists, quality control limits, and/or reporting limits, please contact the CRL Sample Coordinator to discuss. (Thompson.robert@epa.gov, 312-353-9078)

CRL DATA FORMAT

The CRL standard data deliverable includes: 1) a pdf of the work order 2) a pdf of the final Level II report and 3) an electronic data deliverable (EDD) that includes batch quality control sample data. EDD typically refers to an Excel spreadsheet of the data, but EDDs are available in a variety of formats and can be customized upon request. A full data package (Level IV) is also available upon request and will be transmitted electronically via the CRL SharePoint. Contact Sylvia Griffin, CRL Data Coordinator, for additional details. (Griffin.sylvia@epa.gov, 312-353-9073)

CRL SAMPLE DISPOSAL POLICY

Due to space limitations in a controlled temperature environment, samples are relocated to secure room temperature storage six months after the analysis completion of the project. Notification of the intent to relocate the samples is given to the customer with sufficient time for the customer to respond with any objections. Samples remain in secure room temperature storage until the case/project is completed and the samples are no longer needed. Notification is given to the customer with sufficient time for customer response prior to sample disposal.

CRL SAMPLE SHIPMENT REQUIREMENTS

Before collecting samples, please refer to the attached table for sample sizes, containers, and preservatives. Notify the CRL Sample Custodian (312.353.9083, Snyder.robert@epa.gov) and the CRL Sample Coordinator (312.353.9078, Thompson.robert@epa.gov) before shipping any samples and to arrange for sample receipt.

When packing samples for shipment:

- ✓ Seal individual samples in plastic bags, preferably Ziploc bags.
- ✓ The temperature of samples requiring refrigeration during transport MUST be maintained at or below 6°C.
- ✓ Ice in a sealed plastic bag or reusable ice substitute freeze packs are acceptable cooling media.
- ✓ Chain of custody forms MUST be sealed in a large Ziploc bag and taped to the inside of the cooler lid.
- ✓ Include the address to which the cooler should be returned.

After items are packed for shipment, secure the cooler with tape and attach a custody seal across the seam of the cooler lid.

All samples MUST be shipped overnight to arrive Monday thru Friday or hand-delivered. No deliveries are accepted on weekends or Federal holidays. Exceptions may be made on a case by case basis depending on sampling priority/emergency status.

Send all samples to:

Robert Snyder
US EPA Region 5
Chicago Regional Laboratory
536 S. Clark Street, 10th Floor
Chicago, IL 60605



U.S. EPA CHICAGO REGIONAL LABORATORY HOLDING TIME AND CONTAINER REQUIREMENTS FOR WATER / AQUEOUS SAMPLES

DISCLAIMER: This table represents The Chicago Regional Laboratory's (CRL) recommended guidelines. Additional containers may be required for laboratory quality control samples (see notes section). There are non-routine analytes (reported upon request) that may require modification to the specifications detailed in this table. It is the client's responsibility to confirm container, preservation, and holding time requirements for a project prior to initiating sampling. This includes any equipment procurements, if applicable. No brand endorsements are made or implied.

General Chemistry	CRL SOP(s)	Reference Method	Holding Time (days)	Min. Volume (mLs) ¹	Container ^a	Preservation	
Acidity	AIG004A	SM 2310	14	50	500 mL Poly	<6 C	
Alkalinity	AIG005	SM 2320 B	14	50	500 mL Poly	<6 C	
Ammonia (Nitrogen, NH ₃) Distilled	AIG029B	SM 4500-NH ₃ B/H	28	50	500 mL Poly	pH<2, H ₂ SO ₄ , <6 C	
Anions (Br, Cl, F, NO ₂ , NO ₃ , PO ₄ ³⁻ , SO ₄)	AIG045A	EPA 300.0	2 ^b or 28	10	250 mL Poly	<6 C	
Biochemical Oxygen Demand (BOD) 5-day	AIG006, A	SM 5210 B	2	60	1 L Poly	<6 C	
BOD, Carbonaceous (cBOD)	AIG006, A	SM 5210 B	2	60	1 L Poly	<6 C	
Corrosivity	AIG003	EPA 9040C	365	20	250 mL Amber	<6 C	
Cyanide, Amenable	AIG025A	SM 4500 CN ⁻ G	14	50	500 mL Poly	dechlorinate ^c NaOH, pH>10, <6 C	
Cyanide, Total	AIG025C	EPA 335.4	14	50	500 mL Poly	dechlorinate ^c NaOH, pH>10, <6C	
Ignitability (Flashpoint)	AIG048A, B	EPA 1010A , 1020B	365	100	250 mL Clear	<6 C	
Nitrogen, Nitrate+Nitrite	AIG031B	ASTM D7781-14	28	10	500 mL Poly	pH<2, H ₂ SO ₄ , <6 C	
Nitrogen, Total Kjeldahl (TKN)	AIG035B	EPA 351.2	28	10	500 mL Poly	pH<2, H ₂ SO ₄ , <6 C	
Organic Carbon, Dissolved (DOC)	AIG021D	EPA 5310B	28	20	500 mL Poly	field filtered ^d pH<2, H ₂ SO ₄ , <6 C	
Organic Carbon, Total (TOC)	AIG021D	EPA 5310B	28	20	500 mL Poly	pH<2, H ₂ SO ₄ , <6 C	
Paint Filter Liquid Test	AIG010	EPA 9095B	30	100	250 mL Amber	<6 C	
pH	AIG002	SM 4500-H ⁺ B	15 min	50	250 mL Poly	<6 C	
Phosphorus, Total Dissolved (TDP)	AIG034B	EPA 365.4	28	10	500 mL Poly	field filtered ^d pH<2, H ₂ SO ₄ , <6 C	
Phosphorus, Total (TP)	AIG034B	EPA 365.4	28	10	500 mL Poly	pH<2, H ₂ SO ₄ , <6 C	
Solids, Total Dissolved (TDS)	AIG017	SM 2540 C	7	50	500 mL Poly	<6 C	
Solids, Total Suspended (TSS)	AIG018	SM 2540 D	7	100	500 mL Poly	<6 C	
Turbidity	AIG054	EPA 180.1	2	30	250 mL Clear	<6 C	
Water Content	AIG015A	EPA 9000	365	10	250 mL Amber	<6 C	
Metals	CRL SOP(s)	Reference Method	Holding Time (days)	Min. Volume (mLs) ¹	Container	Preservation	
Chromium (VI)	AIG032A	EPA 218.6	28	50	250 mL Poly	pH 9.3-9.7, <6 C NaOH/(NH ₄) ₂ SO ₄	
Hardness	Metals026	SM 2340 B	180	50	500 mL Poly	pH<2, HNO ₃	
Mercury (Hg)	AIG044D, E	EPA 245.1/7470A	28	20	500 mL Poly	pH<2, HNO ₃	
Metals, Total	Metals001, 003, 003A	EPA 200.7/200.8 EPA 6010D/6020B	180	50	500 mL Poly	pH<2, HNO ₃	
Metals, Dissolved	Metals001, 003, 003A	EPA 200.7/200.8 EPA 6010D/6020B	180	50	500 mL Poly	field filtered ^d pH<2, HNO ₃	
Organics	CRL SOP(s)	Reference Method	Holding Time (days)	Min. Volume (mLs) ¹	Container	MS ^m MSD	Preservation
1,4-Dioxane (low-level)	MS035	EPA 522/8000D	28 ^g	250	2 - 250 mL Amber	2	pH<2, NaHSO ₄ , <6 C
Chloroethalonil	MS033	EPA 525.3/8270D	7 ^f	40	3 - 40 mL Amber VOA	2	<6 C
Oil and Grease	GC030, 32	EPA 1664B	28	1 L	2 - 1L Clear wide-mouth	2	pH<2, H ₂ SO ₄ , <6 C
Polychlorinated Biphenyls (PCBs)	GC002, 003	EPA 608/8082A	7 ^h or 365 ^f	1 L	2 - 1L Amber	2	<6 C
PCB Congeners (oil only)	MS034	NA	365	1 gram	4 oz. jar	1	<6 C
Perfluorinated Compounds (PFCs)	OM012	NA	28	10	2 - 15 mL Polypropylene tube (preweighed)	4	<6 C
Pesticides (low level)	OM019	NA	28 ^f	10	3 - 40 mL amber VOA	2	<6 C
Pesticides, Chlorinated	GC001	EPA 608/8081B	7 ^f	1 L	2 - 1L Amber	2	<6 C
Petroleum Hydrocarbons (TPH as DRO/ORO)	GC034	EPA 8015C	7 ^f	1 L	2 - 1L Amber	2	<6 C
Semi-Volatile Organic Compounds (SVOCs)	MS026, 27	EPA 625/8270D	7 ^f	1 L	2 - 1L Amber	2	<6 C
Tetradecylphosphonium chloride (TTPC)	OM016	NA	30	10	3 - 40 mL Amber VOA	2	<6 C
Volatile Organic Compounds (VOCs)	MS023, 24	EPA 624/8260C	7 (unpreserved) 14 (Preserved)	40	3 - 40mL VOA no headspace	2	pH<2, HCl, <6 C
Waste Characterization	CRL SOP(s)	Reference Method	Holding Time (days)	Min. Volume (mLs) ¹	Container		Preservation
Toxicity Characteristic Leaching Procedure (TCLP) ^h	GEN019	EPA 1311	Varies ⁱ	Varies ^j	Varies		<6 C

Notes:

- ^a Orthophosphate must be field filtered
- ^b Nitrite, nitrate, and ortho-phosphate have a 48 hour holding time
- ^c Dechlorinate with ascorbic acid
- ^d Field filtering should use a 0.45 µm filter
- ^e All containers must be filled completely and maintained on ice at ≤ 6 C
- ^f 40 day holding time post extraction
- ^g 28 day holding time post extraction

- ^h Can be requested for metals, Hg, Pesticides, SVOCs and VOCs
- ⁱ Field collection->TCLP ext. (in days): 14 for organics, 28 for Hg, 180 for metals
- ^j Contact CRL for additional details and/or options
- ^k Applicable to method 608 only
- ^l Per sample. Does not include amount needed for QC samples or excess needed for dilutions/reanalysis
- ^m Extra containers needed for MS/MSD location. Frequency = 1/20 field samples



U.S. EPA CHICAGO REGIONAL LABORATORY HOLDING TIME AND CONTAINER REQUIREMENTS FOR SOIL / SOLID SAMPLES

DISCLAIMER: This table represents The Chicago Regional Laboratory's (CRL) recommended guidelines. Additional containers may be required for laboratory quality control samples (see notes section). There are non-routine analytes (reported upon request) that may require modification to the specifications detailed in this table. It is the client's responsibility to confirm container, preservation, and holding time requirements for a project prior to initiating sampling. This includes any equipment procurements, if applicable. No brand endorsements are made or implied.

General Chemistry	CRL SOP(s)	Reference Method	Holding Time (days)	Min. Mass (g) ^l	Container ^c	Preservation ^d
Ammonia (Nitrogen, NH ₃)	AIG029B, 22A	SM 4500-NH ₃ B/H	28	1	4 oz. jar	<6 C
Anions (Br, Cl, F, NO ₃ , NO ₂ , PO ₄ , SO ₄)	AIG039, 45A	EPA 300.0	2 ^{a,b} or 28 ^b	10	4 oz. jar	<6 C
Chemical Oxygen Demand (COD)	AIG007A, 22A	410.4	28 ^b	10	4 oz. jar	<6 C
Cyanide, Total	AIG025B, C	EPA 335.4	14	1	4 oz. jar	<6 C
Nitrogen, Total Kjeldahl (TKN)	AIG022A, 35B	EPA 351.2	28 ^b	1	4 oz. jar	<6 C
Organic Carbon, Total (TOC)	AIG009A	ASA-SSSA	28 ^b	1	4 oz. jar	<6 C
Particle Size	AIG038, 38A	ASTM D2487-93	365	100	16 oz. jar	<6 C
pH	AIG008	EPA 9045D	365	20	4 oz. jar	<6 C
Phosphorus, Total (TP)	AIG022A, 34B	EPA 365.4	28 ^b	1	4 oz. jar	<6 C
% Solids	AIG019	SM 2540 G	7	10	4 oz. jar	<6 C
Metals	CRL SOP(s)	Reference Method	Holding Time (days)	Min. Mass (g) ^l	Container	Preservation
Chromium (VI)	AIG033A	EPA 7199/3060A	30	2.5	4 oz. jar	<6 C
Mercury (Hg)	AIG043C,D,E	EPA 245.5/7471B EPA 7473	28	1	4 oz. jar	<6 C
Metals, Total	Metals001, 003A, 004	EPA 200.7/200.8 EPA 6010C,D/6020B	180	100	4 oz. jar	<6 C
Organics	CRL SOP(s)	Reference Method	Holding Time (days)	Min. Mass (g) ^l	Container	Preservation
Pesticides, Chlorinated	GC001	EPA 8081B	14 ^m	10	8 oz. jar	<6 C
Polychlorinated Biphenyls (PCBs)	GC002, 003	EPA 8082A	365 ^m	10	8 oz. jar	<6 C
PCB Congeners	MS034	NA	365	30	8 oz. jar	<6 C
Perfluorinated Compounds (PFCs)	OM013	NA	28	2	50 mL Polypropylene Tube ^k	<6 C
Petroleum Hydrocarbons (TPH as DRO/ORO)	GC034	EPA 8015C	14 ^m	30	8 oz. jar	<6 C
Polycyclic Aromatic Hydrocarbons, Alkylated	MS026	NA	14 ^m	30	8 oz. jar	<6 C
Semi-Volatile Organic Compounds (SVOCs)	MS026	EPA 8270D	14 ^m	30	8 oz. jar	<6 C
Tetradecylphosphonium chloride (TTPC)	OM017	NA	NA	2	4 oz. jar	<6 C
Volatile Organic Compounds (VOCs)	MS001	EPA 8260C	2	5	3 Encores ^{™e} or 3 VOA vials w/ stir bar ^{e,f,j}	<6 C
Waste Characterization	CRL SOP(s)	Reference Method	Holding Time (days)	Min. Mass (g) ^l	Container	Preservation
Toxicity Characteristic Leaching Procedure (TCLP) ^f	GEN019	EPA 1311	Varies ^h	Varies ^l	16 oz. jar	<6 C
HOLDING TIME AND CONTAINER REQUIREMENTS FOR FILTERS / WIPE SAMPLES						
Organics	CRL SOP(s)	Reference Method	Holding Time (days)	Num. of Wipes	Container	Preservation
Polychlorinated Biphenyls (PCBs)	GC002, 003	EPA 8082A	365 ^m	1 wipe w/hexane	4 oz. jar	<6 C
Semi-Volatile Organic Compounds (SVOCs)	MS026	EPA 8270D	14 ^m	1 wipe w/ isopropanol	4 oz. jar	<6 C
HOLDING TIME AND CONTAINER REQUIREMENTS FOR AIR / VAPOR SAMPLES						
Volatiles	CRL SOP(s)	Reference Method	Holding Time (days)	Pressure	Vessel	Preservation
Air Toxics	MS005	TO-15	30	approx. -7 "Hg	2.7 L Summa ⁱ	Ambient

Notes:

^a Nitrite, nitrate, and ortho-phosphate have a 48 hour holding time

^b Holding time after extraction

^c All jars should be wide mouthed and have a Teflon lid

^d All containers must be filled completely and maintained on ice at ≤ 6 C

^e If no additional organics are requested, a 4 oz. jar must be submitted for % solids. For MS/MSD locations, 3 extra encores/VOA vials are need. Frequency = 1/20 field samples

^f Dispensed in preweighed 40 mL VOA vials with stir bar.

Preferred over Encore[™] or similar. No brands are endorsed by CRL.

^g Can be requested for metals, Hg, Pesticides, SVOCs and VOCs

^h Field collection->TCLP ext. (in days): 14 for organics, 28 for Hg, 180 for metals

^j Contact CRL for additional details and/or options

^k Collected w/ a 5 gram coring device (e.g. Terracore[™] or similar)

^l Must be preweighed

^m Per sample. Does not include amount needed for QC samples or excess needed for dilutions/reanalysis

ⁿ 40 day holding time post extraction

Document No.: R5-ARD-0003-r2

Title: VOC Sampling

Effective Date: 09/29/2017

APPENDIX B

CRL Sample Label

1. Completed CRL Sample Label – Example

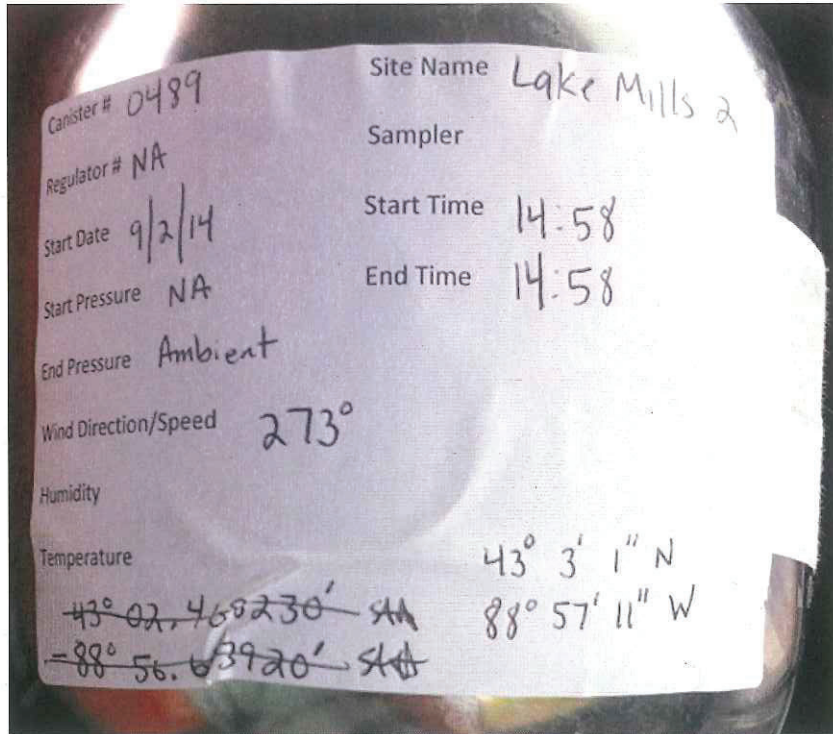

Document No.: R5-ARD-0003-r2
 Title: VOC Sampling
 Effective Date: 09/29/2017

APPENDIX C

CRL Chain of Custody

1. Completed CRL Chain of Custody Form – Example

U.S. GOVERNMENT OFFICE 199-747-251

ENVIRONMENTAL PROTECTION AGENCY
Office of Enforcement

REGION 5
77 West Jackson Boulevard
Chicago, Illinois 60604
Activity Code:

CHAIN OF CUSTODY RECORD

PROJ. NO.	PROJECT NAME		SAMPLERS: (Print Name and Sign)		NO. OF CONTAINERS	STATION LOCATION	TAG NUMBERS
	Verso		Scott Hamilton Justin Coughlin				
STA. NO.	DATE	TIME	COMP	GRAB			
1	7/24	14:26	X		44.40622968, -89.83103204	1	SN 01117 DW
2	7/24	14:33	X		44.40623587, -89.83040368	1	SN 00112 DW
3	7/24	14:43	X		44.37229245, -89.82745909	1	SN 00292 UPR/SN 0117 UW
4	7/24	14:59	X		44.40733706, -89.83119574	1	SN 00124 DW-C / SN 03496 (Reg.)
5	7/24	15:21	X		44.38756892, -89.820635	1	SN 00289 UW-C / SN 03500 (Reg.)
6	7/25	14:40	X		44.42052801, -89.8346142	1	SN 01113 DW
7	7/25	15:09	X		44.41958244, -89.83545427	1	SN 01098 DW
8	7/25	15:30	X		44.42085309, -89.83265502	1	SN 109 DW
9	7/25		X		VOID SAMPLE		SN 01105 DW-C / SN 3500 (Reg.)
10	7/25	15:43	X		44.42085348, -89.83285531	1	SN 01100 DW-C / SN 3500 (Reg.)
11	7/25	15:59	X		44.41770465, -89.83092477	1	SN 00321 DW-SHA/SN 03496 (Reg.)
12	7/26	12:14	X		43.02058677, -87.89803607	1	SN 00286

Relinquished by: (Signature)	Date / Time	Received by: (Signature)	Ship To:
<i>[Signature]</i>	7/26/17 15:21		
Relinquished by: (Signature)	Date / Time	Received by: (Signature)	ATTN:
Relinquished by: (Signature)	Date / Time	Received for Laboratory by: (Signature)	Airbill Number
		<i>[Signature]</i>	
Chain of Custody Seal Numbers			

Distribution: White - Accompanies Shipment; Pink - Coordinator Field Files; Yellow - Laboratory File

5-68423

Printed on Recycled Paper/Printed with Soy-Based Ink

Document No.: R5-ARD-0003-r2
 Title: VOC Sampling
 Effective Date: 09/29/2017

APPENDIX D COMPENDIUM METHOD TO-15 CANISTER SAMPLING FIELD TEST DATA SHEET

VOCs Method TO-15

**COMPENDIUM METHOD TO-15
 CANISTER SAMPLING FIELD TEST DATA SHEET**

A. GENERAL INFORMATION

SITE LOCATION: _____ SHIPPING DATE: _____
 SITE ADDRESS: _____ CANISTER SERIAL NO.: _____
 _____ SAMPLER ID: _____
 SAMPLING DATE: _____ OPERATOR: _____
 CANISTER LEAK
 CHECK DATE: _____

B. SAMPLING INFORMATION

	TEMPERATURE				PRESSURE	
	INTERIOR	AMBIENT	MAXIMUM	MINIMUM	CANISTER PRESSURE	
START						
STOP						

	SAMPLING TIMES		FLOW RATES		
	LOCAL TIME	ELAPSED TIME METER READING	MANIFOLD FLOW RATE	CANISTER FLOW RATE	FLOW CONTROLLER READOUT
START					
STOP					

SAMPLING SYSTEM CERTIFICATION DATE: _____
 QUARTERLY RECERTIFICATION DATE: _____

C. LABORATORY INFORMATION

DATA RECEIVED: _____
 RECEIVED BY: _____
 INITIAL PRESSURE: _____
 FINAL PRESSURE: _____
 DILUTION FACTOR: _____
 ANALYSIS
 GC-FID-ECD DATE: _____
 GC-MSD-SCAN DATE: _____
 GC-MSD-SIM DATE: _____
 RESULTS*: _____

 GC-FID-ECD: _____
 GC-MSD-SCAN: _____
 GC-MSD-SIM: _____

 SIGNATURE/TITLE

Figure 9. Canister sampling field test data sheet (FTDS).