



NM0028355
Permit
Notice

Environment, Safety, Health & Quality
P.O. Box 1663, K491
Los Alamos, New Mexico 87545
(505) 667-0666/FAX: (505) 667-5224

National Nuclear Security Administration
Los Alamos Site Office, A316
3747 West Jemez Road
Los Alamos, New Mexico 87545
(505) 667-5794/FAX (505) 667-5948

Date: February 23, 2011
Refer To: ENV-RCRA-11-0027
LAUR: 11-00881

Ms. Mary Simmons
U.S. Environmental Protection Agency, Region 6
Compliance Assurance and Enforcement Division
Water Enforcement Branch (6SF)
1445 Ross Avenue, Suite 1200
Dallas, TX 75202-2733

Dear Ms. Simmons:

SUBJECT: LOS ALAMOS NATIONAL LABORATORY, NPDES PERMIT NO. NM0028355, NOTICE OF PLANNED CHANGE AT NPDES OUTFALL 051

The National Pollutant Discharge Elimination System (NPDES) Permit No. NM0028355 for the National Nuclear Security Administration (NNSA) and Los Alamos National Security, LLC (LANS) requires the permittee(s) to notify the U. S. Environmental Protection Agency (EPA) regarding any physical alterations or additions to the permitted facility that could significantly change the nature or increase the quantity of pollutants discharged (see Part III.D.1.a. *Reporting Requirements*).

The Radioactive Liquid Waste Treatment Facility (RLWTF) is making modifications to the low-level wastewater treatment system. Modifications include installing pipes and components to bypass the existing RLWTF gravity sand filter and tubular ultra-filter and replace the bypassed treatment processes with a pressure media filtration and cartridge filtration capability. The installation of these new filtration capabilities will provide the RLWTF with reliable filtration downstream of the process clarifier and upstream of the reverse osmosis unit. Additionally, the seawater reverse osmosis unit (SWRO) and associated reject tank have been removed from the treatment system. A pilot study was conducted by RLWTF representatives to evaluate if the volume of the regular reverse osmosis (RO) concentrate stream could be reduced using a SWRO unit. The pilot study has been completed and the hoses to the SWRO have been disconnected. Enclosure 1 highlights the aforementioned treatment system modifications. Enclosure 2 represents the modified treatment schematic to be in operation in late July or early August 2011.

Additionally, in April 2011, the RLWTF will initiate the use of magnesium hydroxide instead of calcium hydroxide in the facility's treatment system clarifier. Magnesium hydroxide raises the pH in

the clarifier and is the source of the hydroxide ion that precipitates with the ferric iron. RLWTF treatment operators would like to use magnesium hydroxide rather than calcium hydroxide because it has been proven to be more effective in silica removal in the clarifier, which then reduces silica fouling of the reverse osmosis (RO) membranes and the Hydrochem waste evaporator heat exchanger plates. The Material Safety Data Sheet (MSDS) for magnesium hydroxide is enclosed for your review (See Enclosure 3).

Please contact Marc Bailey at (505) 665-8135 or Mike Saladen at (505) 665-6085 of the Water Quality and RCRA Group (ENV-RCRA) if you have questions.

Sincerely,



Anthony R. Grieggs
Group Leader
Water Quality & RCRA Group (ENV-RCRA)
Los Alamos National Security, LLC

Sincerely,

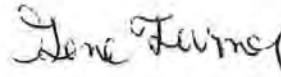

Gene Turner
Environmental Permitting Manager
Environmental Projects Office
Los Alamos Site Office
National Nuclear Security Administration

ARG:GT:MS/lm

Enclosure: a/s

Cy: Brent Larsen, USEPA/Region 6, Dallas, TX, w/enc.
Isaac Chen, USEPA/Region 6, Dallas, TX, w/enc.
Glenn Saums, NMED/SWQB, Santa Fe, NM, w/enc.
William Olson, NMED/GWQB, Santa Fe, NM, w/enc.
George Rael, LASO-EO, w/enc., A316
Steve Yanicak, LASO-GOV, w/enc., M894
Michael B. Mallory, PADOPS, w/o enc., AI02
Robert L. McQuinn, ADHHO, w/o enc., K778
Carl A. Beard, ADPMS, w/o enc., E585
J. Chris Cantwell, ADESHQ, w/o enc., K491
Robert Mason, TA55-DO, w/enc., E583
Hugh McGovern, TA-55-RLW, w/enc., E518
Pete Worland, TA-55-RLW, w/enc., E518
Mike Saladen, ENV-RCRA, w/enc., K490, (E-File)
Marc Bailey, ENV-RCRA, w/enc., K490, (E-File)
Bob Beers, ENV-RCRA, w/enc., K490, (E-File)
Cindy Blackwell, LC-LESH, w/o enc., A187
ENV-RCRA File, w/enc., K490
IRM-RMMSO, w/enc., A150

ENCLOSURE 1

**Changes to LANL Radioactive Liquid Waste Treatment Facility (TA-50)
Process Schematic (as of 12/06/2010)**

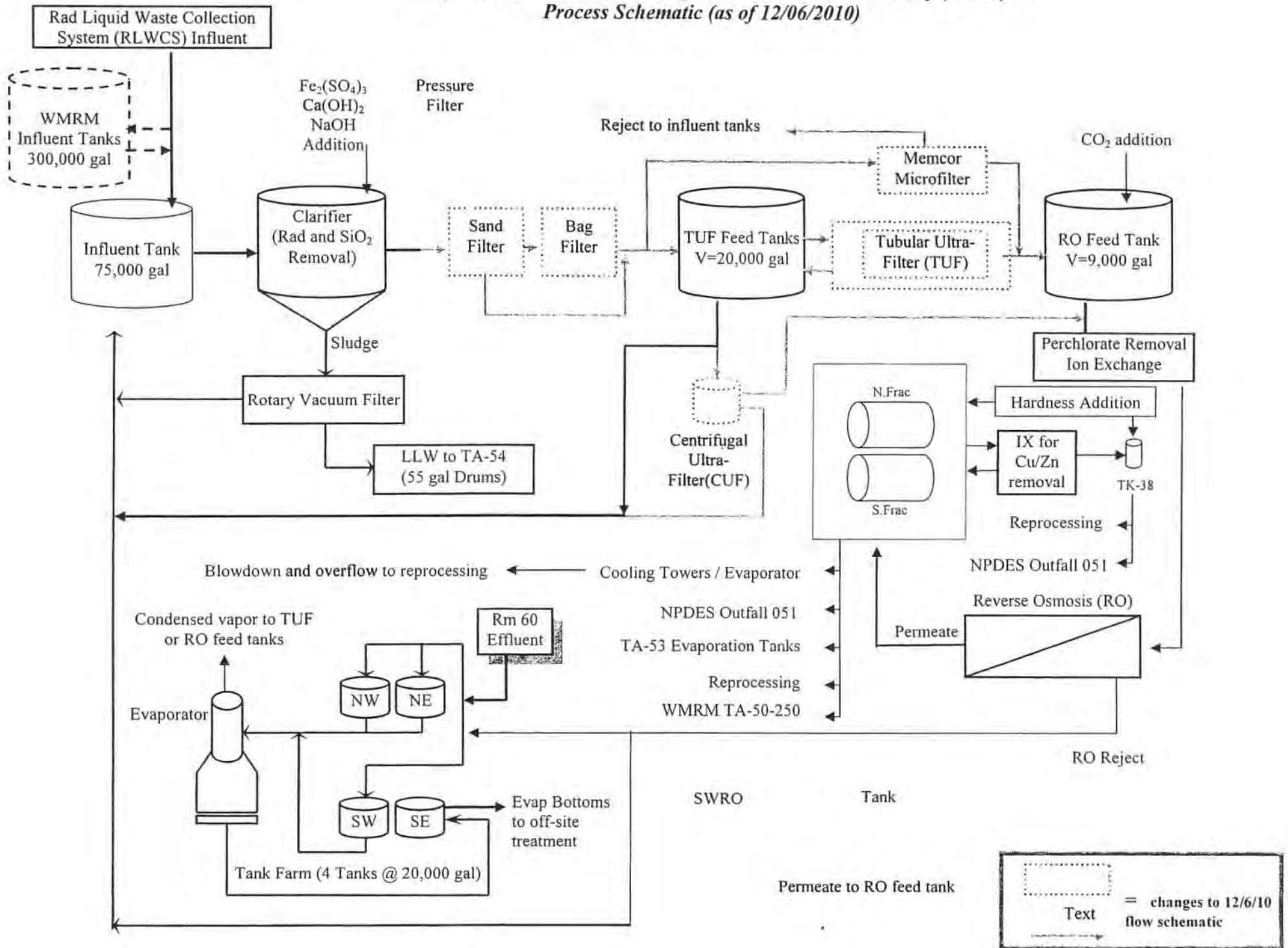

ENCLOSURE 2

ENCLOSURE 3

Mag Hydrocode



Univar USA Inc Material Safety Data Sheet

MSDS No:

Version No:

Order No:

Univar USA Inc., 17425 NE Union Hill Rd., Redmond WA 98052
(425) 889 3400

Emergency Assistance

For emergency assistance involving chemicals call
Chemtec - (800) 424-9300

UNIVAR USA INC.
ISSUE DATE:2000-04-17
Annotation:

MSDS NO:P14725V
VERSION:010 2006-08-18

The Version Date and Number for this MSDS is : 08/18/2006 - #010

SECTION I PRODUCT IDENTIFICATION

PRODUCT NAME: MAGNESIUM HYDROXIDE SOLUTION

MSDS #: P14725V

DATE ISSUED: 04/17/2000

SUPERSEDES: 08/08/1997

ISSUED BY: 008497

REVIEWED DATE: 07/16/2004

This MSDS has been reviewed on 07/16/2004, and is
current as of the DATE ISSUED above.

SECTION I Chemical Product And Company Identification

Product Name: Magnesium Hydroxide Solution
Hi-Chem Mag-50

CAS NUMBER: 1309-42-8

Distributed by:
Univar USA Inc.
17425 NE Union Hill Road
Redmond, WA 98052
425-889-3400

Section II Composition/Information On Ingredients

Chemical Name	CAS Number	%	Exposure Limits (TWA) in Air		
			ACGIH TLV	OSHA PEL	STEL
Magnesium Hydroxide	1309-42-8	51-65	10 mg/m3	15 mg/m3	N/A
			(total dust)	(total dust)	
			5 mg/m3		
			(respirable dust)		

Section III Hazard Identification

ROUTES OF EXPOSURE: N/A

SUMMARY OF ACUTE HEALTH HAZARDS The product presents a very low health

UNIVAR USA INC.
ISSUE DATE:2000-04-17

MSDS NO:P14725V
VERSION:010 2006-08-18

Annotation:

risk. Magnesium hydroxide is a general purpose food additive. Dust generated from the dried product is classified as a nuisance dust.

INGESTION: Ingestion is unlikely. If ingested in sufficient quantity, may cause gastrointestinal disturbances. Symptoms may include irritation, nausea, vomiting, abdominal pain and diarrhea.

INHALATION: May irritate the respiratory tract on prolonged or repeated contact. May aggravate preexisting respiratory conditions.

SKIN: Repeated or prolonged contact may cause irritation

EYES: May irritate or injure eyes.

SUMMARY OF CHRONIC HEALTH HAZARDS: The excessive inhalation above (TLV) of mineral dust, over long periods of time, may cause industrial bronchitis, reduce breathing capacity, and lead to increased susceptibility to other lung disease.

SIGNS AND SYMPTOMS OF EXPOSURE: N/A

EFFECTS OF OVEREXPOSURE: N/A

MEDICAL CONDITIONS GENERALLY AGGRAVATED BY EXPOSURE: Dust from the dried product may aggravate pre-existing chronic lung conditions such as, but not limited to, bronchitis, emphysema, and asthma.

NOTES TO PHYSICIANS: N/A

Section IV First Aid Measures

INGESTION: Low toxicity. Give 1-2 glasses of water and seek immediate medical attention. Never give anything of mouth to an unconscious person. Leave decision to induce vomiting for medical personnel, since some particles may be aspirated into the lungs.

INHALATION: Move to fresh air; if discomfort persists, get medical attention.

SKIN: Wash with soap and water

EYES: Irrigate immediately with plenty of water. Obtain medical attention if necessary.

Section V Fire Fighting Measures

FLASH POINT: N/A

AUTOIGNITION TEMPERATURE: N/A

LOWER EXPLOSIVE LIMIT: N/A

UPPER EXPLOSIVE LIMIT: N/A

UNUSUAL FIRE AND EXPLOSION HAZARDS: N/A

EXTINGUISHING MEDIA: N/A

SPECIAL FIREFIGHTING PROCEDURES:

FIREFIGHTERS SHOULD WEAR NIOSH-APPROVED, POSITIVE PRESSURE, SELF-CONTAINED BREATHING APPARATUS AND FULL PROTECTIVE CLOTHING WHEN APPROPRIATE.

UNIVAR USA INC.
ISSUE DATE:2000-04-17
Annotation:

MSDS NO:P14725V
VERSION:010 2006-08-18

Section VI Accidental Release Measures

Dike the spilled liquid, and either pump back into original container or cover with clay-type substance for absorption.

Section VII Handling and Storage

Store at ambient temperature. Prevent possible eye and skin contact by wearing protective clothing and equipment.

Section VIII Exposure Controls/Personal Protection

RESPIRATORY PROTECTION: Respirator approved by NIOSH/MSHA are adequate for contaminate concentrations encountered.

VENTILATION: N/A

PROTECTIVE CLOTHING: Gloves are recommended, rubber gloves re recommended when repeated or prolonged contact is likely.

EYE PROTECTION: Safety glasses are recommended.

OTHER PROTECTIVE CLOTHING OR EQUIPMENT: N/A

WORK/HYGIENIC PRACTICES: Avoid contact with the eyes and skin.

Section IX Physical and Chemical Properties

PHYSICAL STATE:	Milky liquid
MELTING POINT/RANGE:	N/A
pH:	10-11
BOILING POINT/RANGE:	212 DEG F, 100 DEG C
APPEARANCE/COLOR ODOR:	White - Off white, No odor
SOLUBILITY IN WATER:	NIL
SPECIFIC GRAVITY (Water = 1):	1.4-1.5
VAPOR DENSITY (Air = 1):	N/A
VAPOR PRESSURE (mmHg):	N/A
MOLECULAR WEIGHT:	N/A
‡ OF SOLUTION:	48-51 51-55 61-65
‡ VOLATILES:	49-52 45-49 35-39

Section X Stability and Reactivity

STABILITY: Stable HAZARDOUS POLYMERIZATION: Will Not Occur

CONDITIONS TO AVOID: N/A

MATERIALS TO AVOID: Acids and maleic anhydride Magnesium hydroxide is soluble in aqueous acids generating heat.

HAZARDOUS DECOMPOSITION PRODUCTS: HEAT AND STEAM

Section XI Toxicological Information

UNIVAR USA INC.
ISSUE DATE:2000-04-17
Annotation:

MSDS NO:P14725V
VERSION:010 2006-08-18

N/A

Section XII Ecological Information

N/A

Section XIII disposal Considerations

May be disposed of in a secured sanitary landfill. Disposal must be done in accordance with Local, State, and Federal regulations.

Section XIV Transport Information

DOT Proper Shipping Name: N/A

DOT Hazard Class/I.D. No: N/A

Section XV Regulatory Information

Reportable Quantity: N/A

NFPA Rating: Health - 1; Fire - 0; Reactivity - 0

0 = Insignificant 1 = Slight 2 = Moderate 3 = High 4 = Extreme

Carcinogenicity Lists: No NTP: No IARC Monograph: No OSHA Regulated: No

Section XVI Other information

SYNONYMS/ COMMON NAMES: Brucite

CHEMICAL FAMILY TYPE: Magnesium Hydroxide

Univar USA Inc Material Safety Data Sheet

For Additional Information contact MSDS Coordinator during business hours, Pacific time: (425) 889-3400

Notice

Univar USA Inc. ("Univar") expressly disclaims all express or implied warranties of merchantability and fitness for a particular purpose, with respect to the product or information provided herein, and shall under no circumstances be liable for incidental or consequential damages.

Do not use ingredient information and/or ingredient percentages in this MSDS as a product specification. For product specification information refer to a product specification sheet and/or a certificate of analysis. These can be obtained from your local Univar sales office.

All information appearing herein is based upon data obtained from the manufacturer and/or recognized technical sources. While the information is believed to be accurate, Univar makes no representations as to its accuracy or sufficiency. Conditions of use are beyond Univar's control and therefore users are responsible to verify this data under their own operating conditions to determine whether the product is suitable for their particular purposes and they assume all risks of their use, handling, and disposal of the product, or from the publication or use of, or reliance upon, information contained herein.

This information relates only to the product designated herein, and does not relate to its use in combination with any other material or in any other process