

Illinois Basin Decatur Project (IBDP)
Class VI Injection Well: Quality Assurance and Surveillance Plan

U.S. EPA ID Number (IL-115-6A-0002)

September 2014

Prepared by:
Archer Daniels Midland Company (ADM)

Table of Contents

A. PROJECT MANAGEMENT	1
A.1. Project/Task Organization	1
A.1.a/b. Key Individuals and Responsibilities	1
A.1.c. Independence from Project QA Manager and Data Gathering	1
A.1.d. QA Project Plan Responsibility	1
A.1.e. Organizational Chart for Key Project Personnel	1
A.2. Problem Definition/Background	2
A.2.a Reasoning	2
A.2.b. Reasons for Initiating the Project	2
A.2.c. Regulatory Information, Applicable Criteria, Action Limits	3
A.3. Project/Task Description	3
A.3.a/b. Summary of Work to be Performed and Work Schedule	3
A.3.c. Geographic Locations	10
A.4. Quality Objectives and Criteria	12
A.4.a. Performance/Masurement Criteria	12
A.4.b. Precision	18
A.4.c. Bias	18
A.4.d. Representativeness	18
A.4.e. Completeness	18
A.4.f. Comparability	19
A.4.g. Method Sensitivity	19
A.5. Special Training/Certifications	20
A.5.a. Specialized Training and Certifications	20
A.5.b/c. Training Provider and Responsibility	20
A.6. Documentation and Records	21
A.6.a. Report Format and Package Information	21
A.6.b. Other Project Documents, Records, and Electronic Files	21
A.6.c/d. Data Storage and Duration	21
A.6.e. QASP Distribution Responsibility	21
B. DATA GENERATION AND ACQUISITION	21
B.1. Sampling Process Design (Experimental Design)	21
B.1.a. Design Strategy	22
Shallow Ground Water Monitoring Strategy	22
Deep Ground Water Monitoring Strategy	22

GM#2 Sampling	22
VW#1 Sampling	22
VW#2 Sampling	22
B.1.b Type and Number of Samples/Test Runs	23
B.1.c. Site/Sampling Locations	23
B.1.d. Sampling Site Contingency	23
B.1.e. Activity Schedule	23
B.1.f. Critical/Informational Data	23
B.1.g. Sources of Variability	23
B.2. Sampling Methods	24
B.2.a/b. Sampling SOPs	24
B.2.c. In-situ Monitoring.	25
B.2.d. Continuous Monitoring.	25
B.2.e. Sample Homogenization, Composition, Filtration.	25
B.2.f. Sample Containers and Volumes	25
B.2.g. Sample Preservation	25
B.2.h. Cleaning/Decontamination of Sampling Equipment	25
B.2.i Support Facilities	25
B.2.j. Corrective Action, Personnel, and Documentation	26
B.3. Sample Handling and Custody	26
B.3.a Maximum Hold Time/Time Before Retrieval	26
B.3.b. Sample Transportation	27
B.3.c. Sampling Documentation	27
B.3.d. Sample Identification	27
B.3.e. Sample Chain-of-Custody	27
B.4. Analytical Methods	29
B.4.a. Analytical SOPs	29
B.4.c. Method Performance Criteria	29
B.4.d. Analytical Failure	29
B.4.e. Sample Disposal	29
B.4.f Laboratory Turnaround	29
B.4.g. Method Validation for Nonstandard Methods	29
B.5. Quality Control	29
B.5.a. QC activities	29
Blanks	29
Duplicates	30
B.5.b. Exceeding Control Limits	30
B.5.c. Calculating Applicable QC Statistics	30

Charge Balance	30
Mass Balance	30
Outliers	30
B.6. Instrument/Equipment Testing, Inspection, and Maintenance	31
B.7. Instrument/Equipment Calibration and Frequency	31
B.7.a. Calibration and Frequency of Calibration	31
B.7.b. Calibration Methodology	31
B.7.c. Calibration Resolution and Documentation	31
B.8. Inspection/Acceptance for Supplies and Consumables	31
B.8.a/b. Supplies, Consumables, and Responsibilities	31
B.9. Nondirect Measurements	32
Seismic Monitoring Methods	32
B.9.a Data Sources	32
B.9.b. Relevance to Project	32
B.9.c. Acceptance Criteria	32
B.9.d. Resources/Facilities Needed	32
B.9.e. Validity Limits and Operating Conditions	32
B.10. Data Management	33
B.10.a. Data Management Scheme	33
B.10.b. Record-keeping and Tracking Practices	33
B.10.c. Data Handling Equipment/Procedures	33
B.10.d. Responsibility	33
B.10.e. Data Archival and Retrieval	33
B.10.f. Hardware and Software Configurations	33
B.10.g. Checklists and Forms	33
C. ASSESSMENT AND OVERSIGHT	33
C.1. Assessments and Response Actions	33
C.1.a. Activities to be Conducted	33
C.1.b. Responsibility for Conducting Assessments	33
C.1.c. Assessment Reporting	33
C.1.d. Corrective Action	34
C.2. Reports to Management	34
C.2.a/b. QA status Reports	34

D. DATA VALIDATION AND USABILITY	34
D.1. Data Review, Verification, and Validation	34
D.1.a. Criteria for Accepting, Rejecting, or Qualifying Data	34
D.2. Verification and Validation Methods	34
D.2.a. Data Verification and Validation Processes	34
D.2.b. Data Verification and Validation Responsibility	34
D.2.c. Issue Resolution Process and Responsibility	34
D.2.d. Checklist, Forms, and Calculations	35
D.3. Reconciliation with User Requirements	35
D.3.a. Evaluation of Data Uncertainty	35
D.3.b. Data Limitations Reporting	35
REFERENCES	36
APPENDICES	37
APPENDIX A. DTS and Down-hole Pressure Gauge Information	37
APPENDIX B. Log Quality Control Reference Manual (LQCRM)	42

List of Tables

Table 1. Summary of post-injection testing and monitoring.	4
Table 2. Instrumentation summary.	7
Table 3. Geophysical surveys summary.	9
Table 4. Summary of analytical and field parameters for Quaternary/Pennsylvanian ground water samples.	13
Table 5. Summary of analytical and field parameters for St. Peter ground water samples.	14
Table 6. Summary of analytical and field parameters for Ironton-Galesville ground water samples.	15
Table 7. Summary of analytical and field parameters for Mt. Simon ground water samples.	16
Table 8. Summary of measurement parameters for field gauges.	17
Table 9. Actionable testing and monitoring outputs.	18
Table 10. Pressure and temperature—downhole quartz gauge specifications.	19
Table 11. Representative logging tool specifications for pulse neutron/RST logging.	19
Table 12. Pressure Field Gauge PIT-009—Injection Tubing Pressure.	19
Table 13. Pressure Field Gauge PIT-012.	20
Table 14. Temperature Field Gauge TIT-019 —Injection Tubing Temperature.	20
Table 15. VW#1 Field Gauge—(MOSDAX) Pressure.	20
Table 16. Stabilization criteria of water quality parameters during shallow well purging.	24
Table 17. Summary of anticipated sample containers, preservation treatments, and holding times.	26
Table 18. Example table of criteria used to evaluate data quality.	35

List of Figures

Figure 1. Archer Daniels Midland Company project organization structure.	2
Figure 2. Location of CCS#1 (C), VW#1 (D), and GM#1 (E).	10
Figure 3. Location of shallow monitoring wells G101, G012, G103, and G104 relative to CCS#1 (red dot).	11
Figure 4. Example label for ground water sample bottles.	27
Figure 5. Example chain-of-custody form.	28

Distribution List

The following project participants should receive the completed Quality Assurance and Surveillance Plan (QASP) and all future updates for the duration of the project. The ADM Corn Plant Manager will be responsible for ensuring that all those on the distribution list will receive the most current copy of the approved Quality Assurance and Surveillance Plan. Names in bold are the primary points of contact with addresses listed below.

ADM**Mark Burau**

Dean Frommelt

Sean Stidham

Mark Atkinson

Archer Daniels Midland Company – Corn Processing
Facilities Contact : Mr. Mark Burau, Corn Plant Manager
Mailing Address : 4666 Faries Parkway
Decatur, IL 62526
Phone : 217-424-5750

A. Project Management

A.1. Project/Task Organization

A.1.a/b. Key Individuals and Responsibilities

The project, led by Archer Daniels Midland Company (ADM), includes participation from several subcontractors. The Testing and Monitoring Activities responsibilities will be shared between ADM and their designated subcontractor and the program will be broken in six subcategories:

- I) Shallow Ground Water Sampling
- II) Deep Ground Water Sampling
- III) Well Logging
- IV) Mechanical Integrity Tests (MITs)
- V) Pressure/Temperature Monitoring
- VI) Geophysical Monitoring

A.1.c. Independence from Project QA Manager and Data Gathering

The majority of the physical samples collected and data gathered as part of the monitoring, verification, and accounting (MVA) program is analyzed, processed, or witnessed by third parties independent and outside of the project management structure.

A.1.d. QA Project Plan Responsibility

ADM will be responsible for maintaining and distributing official, approved QA Project Plan. ADM will periodically review this QASP and consult with USEPA if/when changes to the plan are warranted.

A.1.e. Organizational Chart for Key Project Personnel

Figure 1 shows the organization structure of the project. ADM will provide to the UIC Program Director a contact list of individuals fulfilling these roles.

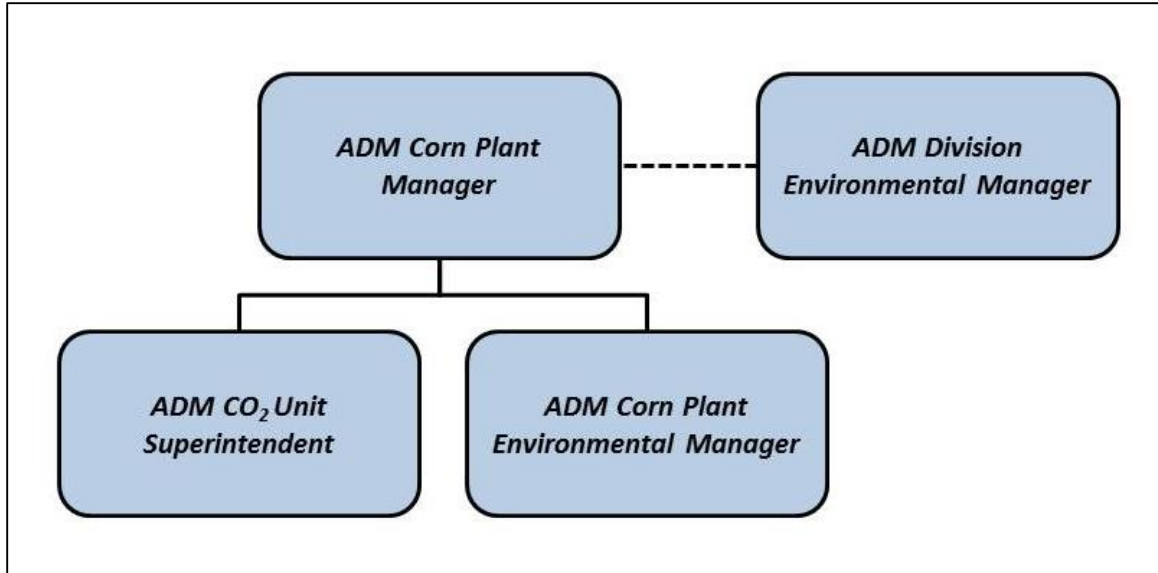

Figure 1. Archer Daniels Midland Company project organization structure.

A.2. Problem Definition/Background

A.2.a Reasoning

The Illinois Basin Decatur Project (IBDP) MVA program has verification and environmental monitoring components. The verification component will provide information to evaluate the integrity of the storage site and monitor the spatial extent of the CO₂ plume. This includes pulse neutron logging, pressure and temperature monitoring, and seismic surveys. The environmental monitoring component will evaluate the quality of the reservoir fluids above and below the confining zone to monitor for unexpected fluid movement indicating a failure of caprock or well integrity. This monitoring includes pulse neutron logging and ground water monitoring.

A robust MVA program has been developed for the IBDP and the nearby Illinois Industrial Carbon Capture and Storage (IL-ICCS) project, which will also be operated by ADM. (The Class VI permit for that project includes a Testing and Monitoring Plan and Post-Injection Site Care and Site Closure Plan that involve similar testing and monitoring activities as those addressed in this QASP.) The primary goal of the IBDP MVA program is to demonstrate that project activities are protective of human health and the environment. To help achieve this goal, this QASP was developed to ensure the quality standards of the testing and monitoring program meet the requirements of the U.S. Environmental Protection Agency’s (USEPA) Underground Injection Control (UIC) Program for Class VI wells.

A.2.b. Reasons for Initiating the Project

The goal of the IBDP injection project is to demonstrate the ability of the Mt. Simon Sandstone to accept and retain industrial-scale volumes of CO₂ for permanent geologic storage thus reducing atmospheric concentrations of CO₂. In order to demonstrate that this can be done safely at commercial scale, a rigorous MVA plan is proposed to ensure the injected CO₂ is retained within the storage site.

A.2.c. Regulatory Information, Applicable Criteria, Action Limits

The Class VI Rule requires owners or operators of Class VI wells to perform several activities during the post-injection phase of the project to verify injection well integrity and monitor fluid migration and the extent of plume and pressure front to ensure the non-endangerment of underground sources of drinking water (USDWs). At CCS#1, these monitoring activities will include mechanical integrity tests (MITs) of CCS#1 and the monitoring wells, monitoring of ground water quality in several zones, and tracking of the CO₂ plume and associated pressure front. This document details both the measurements that will be taken as well as the steps to ensure that the quality of all the data is such that the data can be used with confidence in making decisions during the life of the project.

A.3. Project/Task Description

A.3.a/b. Summary of Work to be Performed and Work Schedule

Table 1 describes the testing and monitoring tasks, reasoning, responsible parties, locations and testing frequency. Table 2 and Table 3 summarize the instrumentation and geophysical surveys, respectively.

Table 1. Summary of post-injection testing and monitoring.

Parameter	Location	Method	Frequency*			Analytical Technique	Lab/Custody	Purpose
			Interim Period	CCS#2 Injection Phase	CCS#2 Post-Injection Phase			
DTS Fiber Optic Temperature	CCS#1 Wellbore	Fiber optic cable	Continuous	Continuous	Yr 1: Continuous Yr 2-10: None	Direct measurement	N/A	Wellbore integrity
	CCS#2 Wellbore	Fiber optic cable	None	Continuous	Yr 1: Continuous Yr 2-10: None	Direct measurement	N/A	Wellbore integrity
Downhole Pressure/ Temperature	CCS#1: Mt Simon	Downhole gauge	Continuous	Continuous	Year 1-3: Continuous Year 4-10: Annual	Direct measurement	N/A	Monitor reservoir
	CCS#2: Mt Simon	Downhole gauge	None	Continuous	Year 1-3: Continuous Year 4-10: Annual	Direct measurement	N/A	Monitor reservoir
	GM#2: St Peter	Downhole gauge	None	Continuous	Year 1-3: Continuous Year 4-10: Annual	Direct measurement	N/A	Monitor reservoir
	VW#1: Ironton-Galesville	Downhole gauge	Continuous	Year 1-3: Continuous Year 3-5: None	None	Direct measurement	N/A	Monitor reservoir
	VW#2: Ironton-Galesville	Downhole gauge	None	Continuous	Year 1-3: Continuous Year 4-10: Annual	Direct measurement	N/A	Monitor reservoir
Mechanical Integrity	CCS#1 (after CCS#1 injection concludes)	Various	N/A	Every 5 years	Prior to P/A	§ 146.87 (a)(4) § 146.89 (c)(2)	N/A	Wellbore integrity
	VW#1 and GM#1	Various	N/A	Every 5 years	N/A	Various	N/A	Wellbore integrity
Passive Seismic	A combination of borehole and surface seismic stations located within the AoR	Multilevel geophones and seismometers	None	Continuous	Continuous	Direct measurement	N/A	Reservoir integrity

* The frequencies at which post-injection testing and monitoring activities will be performed will vary slightly as the phases of the CCS#1 and CCS#2 projects change—from the “interim period” between approval of the CCS#1 permit and commencement of injection operations at CCS#2, to the injection phase at CCS#2, to the post-injection phase following cessation of injection at CCS#2.

Table 1. Summary of post-injection testing and monitoring (continued).

Direct Geochemical Monitoring	Frequency							
	Level	Location Error! Reference source not found.	Method	Interim Period	CCS #2 Injection Phase	CCS #2 Post-Injection Phase	Analytical Technique	Parameters
Shallow Ground Water (Quaternary & Pennsylvanian)	G101, G102, G103, G104	In-situ	Quarterly	Year 1-3 (2015-2017): Semi-Annual	None	Chemical analysis	Table 4	Detection of changes in ground water quality for a shallow USDW
	MVA10LG, MVA11LG, MVA12LG, MVA13LG	In-situ	Quarterly	Yr 1-2: Quarterly Yr 3-5: Semi-Annual	Annual	Chemical analysis	Table 4	Detection of changes in ground water quality for a shallow USDW
Lowermost USDW (St. Peter)	GM#2	Swab valve or other method	Once	Annual	Annual	Chemical analysis	Table 5	Detection of changes in ground water quality in lowermost USDW
Above Confining Zone (Ironton-Galesville)	VW#1	In-situ	Once	Yr 1-3: Annual Yr 4-5: None	None	Chemical analysis	Table 6	Detection of changes in ground water quality for reservoir directly above the confining zone
	VW#2	In-situ	Once	Annual	Annual	Chemical analysis	Table 6	Detection of changes in ground water quality for reservoir directly above the confining zone
In-zone monitoring (Mt. Simon)	VW#1	In-situ	Once	Yr 1-3: Annual Yr 4-5: None	None	Chemical analysis	Table 7	Detection of changes in ground water quality, geochemical monitoring and CO ₂ detection in storage reservoir
In-zone monitoring (Mt. Simon)	VW#2	In-situ	None	Annual	Annual	Chemical analysis	Table 7	Detection of changes in ground water quality, geochemical monitoring and CO ₂ detection in storage reservoir.

*Samples collected using downhole sampling tool run into well on wireline.

*Swab samples collected at surface after well has been swabbed with ample volume to ensure reservoir fluid at saturation

Table 1. Summary of post-injection testing and monitoring (continued).

Indirect Methods of CO₂ Plume Tracking						
Method	Location	Extent/Coverage/Resolution	Interim Period	CCS #2 Injection Phase	CCS #2 Post-Injection Phase	Purpose
Time Lapse 3D VSP	GM#1	Resolution = 30 Acres	None	None	None	Indirect measurement of plume size
Expanded 3D Surface Seismic Survey	Injection Area	Extent of Survey = 3,000 Acres Fold Image Coverage = 2,200 Acres	2015	None	None	Indirect measurement of plume size
Time Lapse 3D Surface Seismic Survey	Injection Area	Extent of Survey = 2,000 Acres Fold Image Coverage = 600 Acres	None	None	2020, 2030	Indirect measurement of plume size

Table 2. Instrumentation summary. T = Temperature; P = Pressure; DTS = Distributed Temperature System; F = Flow.

Monitoring Location	Instrument Type	Monitoring Target (Formation or Other)	Interim Period		CCS #2 Injection Phase		CCS #2 Post-Injection Phase		Explanation
			Data Collection Location(s)	Frequency	Data Collection Location(s)	Frequency	Data Collection Location(s)	Frequency	
CCS#1	DTS	All strata	Distributed measurement to 6325 KB/5631 MSL	Continuous	Distributed measurement to 6325 KB/5631 MSL	Continuous	Distributed measurement to 6325 KB/5631 MSL	Yr 1: Continuous Yr 2-10: None	Monitoring operational parameters and well integrity
	T, P	Mt Simon	1 interval PT @ 6325 KB/5631 MSL Perfs @ 6982–7050 KB 6288–6356 MSL	Continuous	1 interval PT @ 6325 KB/5631 MSL Perfs @ 6982–7050 KB 6288–6356 MSL	Continuous	1 interval PT @ 6325 KB/5631 MSL Perfs @ 6982–7050 KB 6288–6356 MSL	Yr 1-3: Continuous Yr 4-10: Annual	Monitoring operational and equipment parameters
	Geophones	All strata	N/A	None	3 interval array	Note 1.	3 interval array	Note 1.	Note 1: Operator will maintain a passive seismic monitoring system that has the ability to detect seismic events over M1.0 within the AoR.
CCS#2	DTS	All strata	N/A	None	Distributed measurement to 6325 KB/5631 MSL	Continuous	Distributed measurement to 6325 KB/5631 MSL.	Yr 1: Continuous Yr 2-10: None	Monitoring operational parameters and well integrity
	T, P	Mt Simon	N/A	None	1 interval T, P @ 6325 KB/5631 MSL Perfs @ 6718–6881 KB 6024–6187 MSL	Continuous	1 interval T, P @ 6325 KB/5631 MSL Perfs @ 6718–6881 KB 6024–6187 MSL	Yr 1-3: Continuous Yr 4-10: Annual	Monitoring operational, equipment, and permit parameters
VW#1	T, P	Ironton-Galesville	1 interval 4918–5000 KB 4224–4306 MSL	Continuous	1 interval 4918–5000 KB 4224–4306 MSL	Year 1-3: Continuous Year 4-5: None	1 interval 4918–5000 KB 4224–4306 MSL	None	Monitoring seal formation integrity
		Mt Simon	1 interval 6945–5654 KB 6251–4960 MSL	Continuous	1 interval 6945–5654 KB 6251–4960 MSL	Year 1-3: Continuous Year 4-5: None	1 interval 6945–5654 KB 6251–4960 MSL	None	Monitoring plume pressure and temperature front

Table 2. Instrumentation summary. T = Temperature; P = Pressure; DTS = Distributed Temperature System; F = Flow (continued).

Monitoring Location	Instrument Type	Monitoring Target (Formation or Other)	Interim Period		CCS#2 Injection Phase		CCS#2 Post-Injection Phase		Explanation
			Data Collection Location(s)	Frequency	Data Collection Location(s)	Frequency	Data Collection Location(s)	Frequency	
VW#2	T, P	Ironton-Galesville	N/A	None	1 interval 5000 KB 4918 MSL	Continuous	1 interval 5000 KB 4918 MSL	Yr 1-3: Continuous Yr 4-10: Annual	Monitoring seal formation integrity
	T,P	Mt. Simon	N/A	None	4 intervals 7000, 6800, 6300, 5800 KB 6306, 6106, 5606, 5106 MSL	Continuous	4 intervals 7000, 6800, 6300, 5800 KB 6306, 6106, 5606, 5106 MSL	Continuous	Monitoring plume pressure and temperature front
GM#1	Geophones	All strata	20 interval array	Note 1.	20 interval array	Note 1.	20 interval array	Note 1.	Note 1: Operator will maintain a passive seismic monitoring system that has the ability to detect seismic events over M1.0 within the AoR.
GM#2	P	St. Peter	N/A	None	1 interval 3300 KB 2606 MSL	Continuous	1 interval 3300 KB 2606 MSL	Yr 1-3: Continuous Yr 4-10: Annual	Monitoring seal formation integrity
	Geophones	All strata	5 interval array	Note 1.	5 interval array	Note 1.	5 interval array	Note 1.	Note 1: Operator will maintain a passive seismic monitoring system that has the ability to detect seismic events over M1.0 within the AoR.
Seismic Stations	Seismometers & geophones	All strata	Combination of surface and borehole monitoring stations	Note 1.	Combination of surface and borehole monitoring stations	Note 1.	Combination of surface and borehole monitoring stations	Note 1.	Note 1: Operator will maintain a passive seismic monitoring system that has the ability to detect seismic events over M1.0 within the AoR.

Table 3. Geophysical surveys summary.

Monitoring Activity	Well	Tools or Survey Description	Interim Period	CCS #2 Injection Phase	CCS #2 Post-Injection Phase	Explanation
Logging	VW#1	Pulse neutron	Once	Yrs 2, 4	Yrs 1, 3, 5, 7, 10	Fluid movement, salinity, CO ₂ detection, mechanical integrity
	VW#2	Pulse neutron	Once	Yrs 2, 4	Yrs 1, 3, 5, 7, 10	Fluid movement, salinity, CO ₂ detection, mechanical integrity
	CCS#1	Pulse neutron	Once	Yrs 2, 4	Yrs 1, 3, 5, 7, 10	Fluid movement, salinity, CO ₂ detection, mechanical integrity
	CCS#2	Pulse neutron	Once	Yrs 2, 4	Yrs 1, 3, 5, 7, 10	Fluid movement, salinity, CO ₂ detection, mechanical integrity
Seismic	GM#1	Time-lapse VSP survey	None	None	None	Monitor spatial extent of plume
	Injection Area	3D surface seismic survey	2015	None	2020, 2030	Monitor spatial extent of plume

A.3.c. Geographic Locations

Figure 2 and Figure 3 show the IBDP site and monitoring infrastructure.

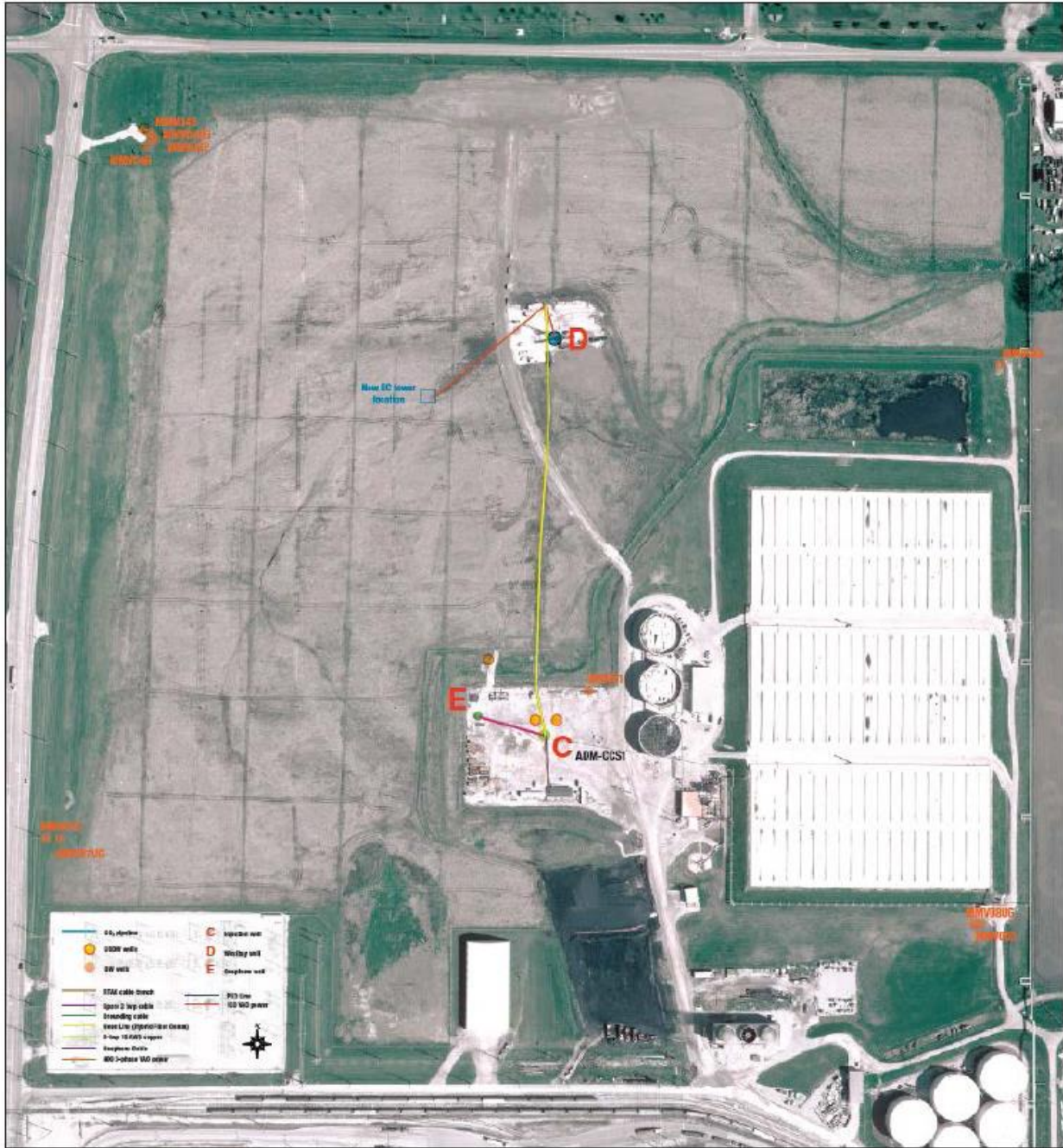





Figure 2. Location of CCS#1 (C), VW#1 (D), and GM#1 (E).



Map Source: Midwest Geological Sequestration Consortium (Dec 2010)

Legend

-  IBDP Study Area
-  Compliance Wells
-  Injection Well

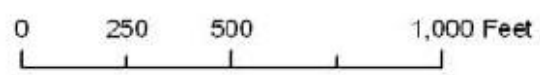

Figure 3. Location of shallow monitoring wells G101, G102, G103, and G104 relative to CCS#1 (red dot).

A.4. Quality Objectives and Criteria

A.4.a. Performance/Measurement Criteria

The overall QA objective for monitoring is to develop and implement procedures for subsurface monitoring, field sampling, laboratory analysis, and reporting which will provide results that will meet the characterization and non-endangerment goals of this project. Ground water monitoring will be conducted during the post-injection phase of the project. Shallow and deep ground water monitoring wells will be used to gather water-quality samples and pressure data. All the ground water analytical and field monitoring parameters for each interval are listed in Table 4 through Table 7. Table 8 shows gauge specifications. Table 9 shows the monitoring outputs. The list of analytes may be reassessed periodically and adjusted to include or exclude analytes based on their effectiveness to the overall monitoring program goals.

Key testing and monitoring areas include:

- I. Shallow Ground Water Sampling
 - Aqueous chemical concentrations
- II. Deep Formation Fluid Sampling
 - Aqueous chemical concentrations
- III. Well Logging
 - Pulse neutron logging
- IV. Mechanical Integrity Tests (MITs)
 - Pressure test casing inspection logging (internal)
 - Noise or oxygen activation logging or other Director-approved logging process (external)
- V. Pressure/Temperature Monitoring
 - Pressure/temperature from in-situ gauges
 - Pressure/temperature from surface gauges
- VI. Geophysical Monitoring
 - Seismic data files (e.g., segd file)
 - Processed time-lapse report

Table 4. Summary of analytical and field parameters for Quaternary/Pennsylvanian ground water samples. All analysis will all be performed by ADM or a designated third party laboratory. ICP = inductively coupled plasma; MS = mass spectrometry; OES = optical emission spectrometry.

Parameters	Analytical Methods ⁽¹⁾	Detection Limit/Range	Typical Precisions	QC Requirements
Cations: Al, Ba, Mn, As, Cd, Cr, Cu, Pb, Sb Se, and Tl	ICP-MS, EPA Method 6020	0.001 to 0.1 mg/L (analyte, dilution and matrix dependent)	±15%	Daily calibration; blanks, duplicates and matrix spikes at 10% or greater frequency
Cations: Ca, Fe, K, Mg, Na, and Si	ICP-OES, EPA Method 6010B	0.005 to 0.5 mg/L (analyte, dilution and matrix dependent)	±15%	Daily calibration; blanks, duplicates and matrix spikes at 10% or greater frequency
Anions: Br, Cl, F, NO₃, and SO₄	Ion Chromatography, EPA Method 300.0	0.02 to 0.13 mg/L (analyte, dilution and matrix dependent)	±15%	Daily calibration; blanks and duplicates at 10% or greater frequency
Dissolved CO₂	Coulometric titration, ASTM D513-11	25 mg/L	±15%	Duplicate measurement; standards at 10% or greater frequency
Total Dissolved Solids	Gravimetry; APHA 2540C	12 mg/L	±10%	Balance calibration, duplicate analysis
Alkalinity	APHA 2320B	4 mg/L	±3 mg/L	Duplicate analysis
pH (field)	EPA 150.1	2 to 12 pH units	±0.2 pH unit	User calibration per manufacturer recommendation
Specific conductance (field)	APHA 2510	0 to 200 mS/cm	±1% of reading	User calibration per manufacturer recommendation
Temperature (field)	Thermocouple	-5 to 50°C	±0.2°C	Factory calibration

Note 1: An equivalent method may be employed with the prior approval of the UIC Program Director.

Table 5. Summary of analytical and field parameters for St. Peter ground water samples. All analysis will be performed by ADM or a designated third party laboratory. ICP = inductively coupled plasma; MS = mass spectrometry; OES = optical emission spectrometry.

Parameters	Analytical Methods ⁽¹⁾	Detection Limit/Range	Typical Precisions	QC Requirements
Cations: Al, Ba, Mn, As, Cd, Cr, Cu, Pb, Sb Se, and Tl	ICP-MS, EPA Method 6020	0.001 to 0.1 mg/L (analyte, dilution and matrix dependent)	±15%	Daily calibration; blanks, duplicates and matrix spikes at 10% or greater frequency
Cations: Ca, Fe, K, Mg, Na, and Si	ICP-OES, EPA Method 6010B	0.005 to 0.5 mg/L (analyte, dilution and matrix dependent)	±15%	Daily calibration; blanks, duplicates and matrix spikes at 10% or greater frequency
Anions: Br, Cl, F, NO ₃ , and SO ₄	Ion Chromatography, EPA Method 300.0	0.02 to 0.13 mg/L (analyte, dilution and matrix dependent)	±15%	Daily calibration; blanks and duplicates at 10% or greater frequency
Dissolved CO₂	Coulometric titration, ASTM D513-11	25 mg/L	±15%	Duplicate measurement; standards at 10% or greater frequency
Isotopes: δ ¹³ C of DIC	Isotope ratio mass spectrometry ²	12.2 mg/L HCO ₃ ⁻ for δ ¹³ C	±0.15‰ for δ ¹³ C	10% duplicates; 4 standards/batch
Total Dissolved Solids	Gravimetry; APHA 2540C	12 mg/L	±10%	Balance calibration, duplicate analysis
Alkalinity	APHA 2320B	4 mg/L	±3 mg/L	Duplicate analysis
pH (field)	EPA 150.1	2 to 12 pH units	±0.2 pH unit	User calibration per manufacturer recommendation
Specific conductance (field)	APHA 2510	0 to 200 mS/cm	±1% of reading	User calibration per manufacturer recommendation
Temperature (field)	Thermocouple	-5 to 50°C	±0.2°C	Factory calibration

Note 1: An equivalent method may be employed with the prior approval of the UIC Program Director.

Note:2: Gas evolution technique by Atekwana and Krishnamurthy (1998), with modifications made by Hackley et al. (2007)

Table 6. Summary of analytical and field parameters for Ironton-Galesville ground water samples. Note: Cation, anion, TDS, and alkalinity measurements will all be performed by a laboratory meeting the requirements under the USEPA Environmental Laboratory Accreditation Program. Isotope and dissolved CO₂ analyses will be performed by ADM or a designated laboratory. ICP = inductively coupled plasma; MS = mass spectrometry; OES = optical emission spectrometry.

Parameters	Analytical Methods ⁽¹⁾	Detection Limit/Range	Typical Precisions	QC Requirements
Cations: Al, Ba, Mn, As, Cd, Cr, Cu, Pb, Sb, Se, and Tl	ICP-MS, EPA Method 6020	0.001 to 0.1 mg/L (analyte, dilution and matrix dependent)	±15%	Daily calibration; blanks, duplicates and matrix spikes at 10% or greater frequency
Cations: Ca, Fe, K, Mg, Na, and Si	ICP-OES, EPA Method 6010B	0.005 to 0.5 mg/L (analyte, dilution and matrix dependent)	±15%	Daily calibration; blanks, duplicates and matrix spikes at 10% or greater frequency
Anions: Br, Cl, F, NO ₃ , and SO ₄	Ion Chromatography, EPA Method 300.0	0.02 to 0.13 mg/L (analyte, dilution and matrix dependent)	±15%	Daily calibration; blanks and duplicates at 10% or greater frequency
Dissolved CO₂	Coulometric titration, ASTM D513-11	25 mg/L	±15%	Duplicate measurement; standards at 10% or greater frequency
Isotopes: δ ¹³ C of DIC	Isotope ratio mass spectrometry ²	12.2 mg/L HCO ₃ ⁻ for δ ¹³ C	±0.15‰ for δ ¹³ C	10% duplicates; 4 standards/batch
Total Dissolved Solids	Gravimetry; APHA 2540C	12 mg/L	±10%	Balance calibration, duplicate analysis
Water Density(field)	Oscillating body method	0.0000 to 2.0000	±0.0002 g/mL	Duplicate measurements
Alkalinity	APHA 2320B	4 mg/L	±3 mg/L	Duplicate analysis
pH (field)	EPA 150.1	2 to 12 pH units	±0.2 pH unit	User calibration per manufacturer recommendation
Specific conductance (field)	APHA 2510	0 to 200 mS/cm	±1% of reading	User calibration per manufacturer recommendation
Temperature (field)	Thermocouple	-5 to 50°C	±0.2°C	Factory calibration

Note 1: An equivalent method may be employed with the prior approval of the UIC Program Director.

Note:2: Gas evolution technique by Atekwana and Krishnamurthy (1998), with modifications made by Hackley et al. (2007)

Table 7. Summary of analytical and field parameters for Mt. Simon ground water samples. All analysis will be performed by ADM or a designated third party laboratory. ICP = inductively coupled plasma; MS = mass spectrometry; OES = optical emission spectrometry.

Parameters	Analytical Methods ⁽¹⁾	Detection Limit/Range	Typical Precisions	QC Requirements
Cations: Al, Ba, Mn, As, Cd, Cr, Cu, Pb, Sb, Se, and Tl	ICP-MS, EPA Method 6020	0.001 to 0.1 mg/L (analyte, dilution and matrix dependent)	±15%	Daily calibration; blanks, duplicates and matrix spikes at 10% or greater frequency
Cations: Ca, Fe, K, Mg, Na, and Si	ICP-OES, EPA Method 6010B	0.005 to 0.5 mg/L (analyte, dilution and matrix dependent)	±15%	Daily calibration; blanks, duplicates and matrix spikes at 10% or greater frequency
Anions: Br, Cl, F, NO ₃ , and SO ₄	Ion Chromatography, EPA Method 300.0	0.02 to 0.13 mg/L (analyte, dilution and matrix dependent)	±15%	Daily calibration; blanks and duplicates at 10% or greater frequency
Dissolved CO₂	Coulometric titration, ASTM D513-11	25 mg/L	±15%	Duplicate measurement; standards at 10% or greater frequency
Isotopes: δ ¹³ C of DIC	Isotope ratio mass spectrometry ²	12.2 mg/L HCO ₃ ⁻ for δ ¹³ C	±0.15‰ for δ ¹³ C	10% duplicates; 4 standards/batch
Total Dissolved Solids	Gravimetry; APHA 2540C	12 mg/L	±10%	Balance calibration, duplicate analysis
Water Density(field)	Oscillating body method	0.0000 to 2.0000	±0.0002 g/mL	Duplicate measurements
Alkalinity	APHA 2320B	4 mg/L	±3 mg/L	Duplicate analysis
pH (field)	EPA 150.1	2 to 12 pH units	±0.2 pH unit	User calibration per manufacturer recommendation
Specific conductance (field)	APHA 2510	0 to 200 mS/cm	±1% of reading	User calibration per manufacturer recommendation
Temperature (field)	Thermocouple	-5 to 50°C	±0.2°C	Factory calibration

Note 1: An equivalent method may be employed with the prior approval of the UIC Program Director.

Note 2: Gas evolution technique by Atekwana and Krishnamurthy (1998), with modifications made by Hackley et al. (2007)

Table 8. Summary of measurement parameters for field gauges.

Parameters	Methods	Detection Limit/Range	Typical Precisions	QC Requirements
Booster pump discharge pressure (PIT-012)	ANSI Z540-1-1994	+/- 0.001 psi / 0-3000 psi	+/- 0.01 psi	Annual Calibration of Scale (3 rd party)
Injection Tubing Temperature (TIT-019)	ANSI Z540-1-1994	+/- 0.001 F / 0-500 F	+/- 0.01 F	Annual Calibration of Scale (3 rd party)
Annulus Pressure (PIT-014)	ANSI Z540-1-1994	+/- 0.001 psi / 0-3000 psi	+/- 0.01 psi	Annual Calibration of Scale (3 rd party)
Injection Tubing Pressure (PIT-009)	ANSI Z540-1-1994	+/- 0.001 psi / 0-3000 psi	+/- 0.01 psi	Annual Calibration of Scale (3 rd party)
Injection Mass Flow Rate (FIT-006)	UNKNOWN	+/- 0.1000% of rate / 50,522-303,133 lb/hr	+/- 0.01 lbs/hr	Annual Calibration of Scale (3 rd party)
Pressures (MOSDAX)	UNKNOWN	+/- 0.01 psi / 0-4000 PSI	+/- 0.1 psi	Annual Calibration of Scale (3 rd party)

Table 9. Actionable testing and monitoring outputs.

	Project Action Limit	Detection Limit	Anticipated Reading
MIT—Pulse neutron logging	Action taken when RST indicates CO ₂ outside of expected range	+/- 0.5 SIGM	Brine saturated ~ 60 CO ₂ saturated ~ 8
Surface and downhole pressure gauges	Action will be taken when pressures are well outside of modeled/expected range	Refer to Table 10 through Table 15	Within injection formation: >80% fracture gradient 0.71 psi/ft
Wellbore integrity—DTS fiber optic temperature	Action will be taken when there is an anomaly in temperature profile	Refer to Appendix A	DTS provides continuous temperature profile
Seismic data files	Detected CO ₂ outside the AOR	Dependent on fluid saturation, and formation velocities	CO ₂ plume migration similar to modeled outcome

A.4.b. Precision

For ground water sampling, data accuracy will be assessed by the collection and analysis of field blanks to test sampling procedures and matrix spikes to test lab procedures. Field blanks will be taken no less than one per sampling event to spot check for sample bottle contamination. Laboratory assessment of analytical precision will be the responsibility of the individual laboratories per their standard operating procedures.

Table 10 through Table 15 summarize the specifications of each monitoring method for pressure, temperature, and logging.

A.4.c. Bias

Laboratory assessment of analytical bias will be the responsibility of the individual laboratories per their standard operating procedures and analytical methodologies. For direct pressure or logging measurements, there is no bias.

A.4.d. Representativeness

For groundwater sampling, data representativeness expresses the degree to which data accurately and precisely represents a characteristic of a population, parameter variations at a sampling point, a process condition, or an environmental condition. The sampling network has been designed to provide data representative of site conditions. For analytical results of individual ground water samples, representativeness will be estimated by ion and mass balances. Ion balances with ±10% error or less will be considered valid. Mass balance assessment will be used in cases where the ion balance is greater than ±10% to help determine the source of error. For a sample and its duplicate, if the relative percent difference is greater than 10%, the sample may be considered non-representative.

A.4.e. Completeness

For ground water sampling, data completeness is a measure of the amount of valid data obtained from a measurement system compared to the amount that was expected to be obtained under normal conditions. It is anticipated that data completeness of 90% for ground water sampling will be acceptable

to meet monitoring goals. For direct pressure and temperature measurements, it is expected that data will be recorded no less than 90% of the time.

A.4.f. Comparability

Data comparability expresses the confidence with which one data set can be compared to another. The data sets to be generated by this project will be very comparable to future data sets because of the use of standard methods and the level of QA/QC effort. If historical ground water quality data become available from other sources, their applicability to the project and level of quality will be assessed prior to use with data gathered on this project. Direct pressure, temperature, and logging measurements will be directly comparable to previously obtained data.

A.4.g. Method Sensitivity

Table 10 through Table 15 provide additional details on gauge specifications and sensitivities.

Table 10. Pressure and temperature—downhole quartz gauge specifications.

Calibrated working pressure range	Atmospheric to 10,000 psi
Initial pressure accuracy	<+/-2 psi over full scale
Pressure resolution	0.005 psi at 1-s sample rate
Pressure drift stability	<+/-1 psi per year over full scale
Calibrated working temperature range	77–266°F
Initial temperature accuracy	<+/-0.9°F per +/-0.27°F
Temperature resolution	0.009°F at 1-s sample rate
Temperature drift stability	<+/-0.1°F per year at 302
Max temperature	302°F

Table 11. Representative logging tool specifications for pulse neutron/RST logging.

Logging speed	1,800 ft/hr
Vertical resolution	15 inches
Investigation	Formation
Temperature rating	302°F
Pressure rating	15,000 psi

Table 12. Pressure Field Gauge PIT-009—Injection Tubing Pressure.

Calibrated working pressure range	0 to 3000 psi and 4–20 mA
Initial pressure accuracy	< 0.04375%
Pressure resolution	0.001 psi and 0.00001 mA
Pressure drift stability	0.125% of upper range limit for 60 months

Table 13. Pressure Field Gauge PIT-012.

Calibrated working pressure range	0 to 3000 psi and 4–20 mA
Initial pressure accuracy	< 0.03125%
Pressure resolution	0.001 psi and 0.00001 mA
Pressure drift stability	0.125% of upper range limit for 60 months

Table 14. Temperature Field Gauge TIT-019 —Injection Tubing Temperature.

Calibrated working temperature range	0 to 500°F and 4–20 mA
Initial temperature accuracy	< 0.0055 %
Temperature resolution	0.001°F and 0.0001 mA
Temperature drift stability	±0.15% of output reading or 0.15 °C (whichever is greater) for 24 months

Table 15. VW#1 Field Gauge—(MOSDAX) Pressure.

Calibrated working pressure range	0 to 4000 psi
Initial pressure accuracy	0.1 % of upper range limit
Pressure resolution	0.1 psi
Pressure drift stability ⁽¹⁾	Estimate <0.3% of output reading for 12 months

Note 1: Operational environment, cycle time, handling, transportation, and storage will affect the probe’s drift stability.

A.5. Special Training/Certifications

A.5.a. Specialized Training and Certifications

The geophysical survey equipment and wireline logging tools will be operated by trained, qualified, and certified personnel, according to the service company which provides the equipment. The subsequent data will be processed and analyzed according to industry standards (Appendix B). No specialized certifications are required for personnel conducting ground water sampling, but field sampling will be conducted by trained personnel. Ground water sampling will be conducted by personnel trained to understand and follow the project specific sampling procedures. Upon request ADM will provide the agency with all laboratory SOPs developed for the specific parameter using the appropriate standard method. Each laboratory technician conducting the analysis on the samples will be trained on the SOP developed for each standard method. ADM will include the technician’s training certification with the annual report.

A.5.b/c. Training Provider and Responsibility

Training for personnel will be provided by the operator or by the subcontractor responsible for the data collection activity.

A.6. Documentation and Records

A.6.a. Report Format and Package Information

An annual report from ADM to USEPA will contain all required project data, including testing and monitoring information as specified by the UIC Class VI permit. Data will be provided in electronic or other formats as required by the UIC Program Director.

A.6.b. Other Project Documents, Records, and Electronic Files

Other documents, records, and electronic files such as well logs, test results, or other data will be provided as required by the UIC Program Director.

A.6.c/d. Data Storage and Duration

ADM or a designated contractor will maintain the required project data as provided elsewhere in the permit.

A.6.e. QASP Distribution Responsibility

The ADM Corn Plant Manager will be responsible for ensuring that all those on the distribution list will receive the most current copy of the approved Quality Assurance and Surveillance Plan.

B. Data Generation and Acquisition

B.1. Sampling Process Design (Experimental Design)

Discussion in this section is focused on ground water and fluid sampling and does not address monitoring methods that do not gather physical samples (e.g., logging, seismic monitoring, and pressure/temperature monitoring). Ground water sampling is planned to include an extensive set of chemical parameters to establish aqueous geochemical reference data. Parameters will include selected constituents that: (1) have primary and secondary USEPA drinking water maximum contaminant levels, (2) are the most responsive to interaction with CO₂ or brine, (3) are needed for quality control, and (4) may be needed for geochemical modeling. The full set of parameters for each sampling interval is given in Table 4 through Table 7. After a sufficient baseline is established following commencement of monitoring at CCS#2, monitoring scope may shift to a subset of indicator parameters that are (1) the most responsive to interaction with CO₂ or brine and (2) are needed for quality control. Implementation of a reduced set of parameters would be done in consultation with the USEPA. Isotopic analyses will be performed on baseline samples to the degree that the information helps verify a condition or establish an understanding of non-project related variations. For non-baseline samples, isotopic analyses may be reduced in all monitoring wells if a review of the historical project results or other data determines that further sampling for isotopes is unneeded. During any period where a reduced set of analytes is used, if statistically significant trends are observed that are the result of unintended CO₂ or brine migration, the analytical list would be expanded to the full set of monitoring parameters. The Ironton-Galesville ground water samples will be analyzed using a laboratory meeting the requirements under the USEPA Environmental Laboratory Accreditation Program. All other samples will be analyzed by the operator or a third party laboratory. Dissolved CO₂ will be analyzed by methods consistent with Test Method B of ASTM D 513-06, "Standard Test Methods for Total and Dissolved Carbon Dioxide in Water" or equivalent. Isotopic analysis will be conducted using established methods.

B.1.a. Design Strategy

Shallow Ground Water Monitoring Strategy

Four dedicated monitoring wells have been selected for shallow ground water monitoring. These wells have already been installed and screened in the Quaternary-age deposits to depths less than 150 ft below ground surface (bgs). The local Quaternary-age deposits are used predominantly as private water well sources in the area. The wells are designated as GIBDP G101, G102, G103, and G104 (Figure 3). The wells were selected to give a spatial distribution around the CO₂ injection well (CCS#1) location. Wells IL-ICCS MVA 10LG, MVA 11LG, MVA 12LG, and MVA 13L will also be used for shallow monitoring during the injection and post-injection phases of the IL-ICCS project.

Deep Ground Water Monitoring Strategy

Monitoring of the deeper St. Peter and Ironton-Galesville Sandstones will be used for early leakage detection in formations that are much closer to the Mt. Simon Sandstone injection reservoir. Fluid sampling at wells VW#1, VW#2, and GM#2 in combination with pressure monitoring, temperature monitoring, and pulse neutron logging will be used to determine if leakage is occurring at or near the injection well. The Ironton-Galesville Sandstone has sufficient permeability (over 100 mD) such that pressure monitoring at the verification wells would detect a failure of the confining zone should it occur. MI testing and DTS monitoring at the injection well will also provide data to ensure the mechanical integrity of the well is maintained. With the planned sampling and monitoring frequencies, it is expected that baseline conditions can be documented, natural variability in conditions can be characterized, unintended brine or CO₂ leakage could be detected if it occurred, and sufficient data will be collected to demonstrate that the effects of CO₂ injection are limited to the intended storage reservoir. No ground water fluid sampling is planned for the Mt. Simon intervals where free phase CO₂ has broken through.

GM#2 Sampling

The IL-ICCS geophysical monitoring well, GM#2, will be used for fluid sampling of the St. Peter Sandstone, a USEPA-identified USDW, after injection commences at CCS#2. At prescribed frequencies (in consultation with USEPA), fluid sampling will occur using a portable swabbing rig or other available sampling technologies. Samples will be analyzed for constituents listed in Table 5 to document baseline fluid chemistry and to detect changes in fluid chemistry that could result from the movement of brine or CO₂ from the storage interval through the seal formation.

VW#1 Sampling

The IBDP verification well, VW#1, will be used to monitor the pressure and temperature in the Ironton-Galesville Sandstone above the Eau Claire Formation, the primary reservoir seal. This well will serve as an early leak detection system by allowing the operator to monitor for changes above the primary caprock. Ground water samples will be collected and analyzed for constituents listed in Table 6 to document baseline fluid chemistry and to detect changes in fluid chemistry that could result from the movement of brine or CO₂ from the storage interval through the seal formation. The well has been completed with a multilevel sampling system and fluid samples will be collected as described by Locke et al. (2013).

VW#2 Sampling

The IL-ICCS verification well, VW#2, will allow monitoring within the Mt. Simon injection zone as well as immediately above the Eau Claire Formation. This well will serve as an early leak detection system by allowing the operator to monitor for changes above the primary caprock. VW#2 will be equipped with a multilevel pressure and temperature monitoring system with fluid sampling capability at four (4) intervals (perforation intervals 2-5; 6800, 6300, 5800, 5000 KB). The system uses packers to isolate each perforation interval and hydraulically operated sliding sleeves to facilitate sampling. Pressure and

temperature will be continuously monitored and recorded in each of the five (5) perforation intervals (perforation intervals 1-5; 7000, 6800, 6300, 5800, 5000 KB). The pressure inside the tubing just above the uppermost packer (~4900 Kb) will be monitored and recorded. At prescribed frequencies (in consultation with USEPA), fluid sampling will occur by opening the appropriate sliding sleeve across from the zone to be sampled. Each sample interval will be analyzed for constituents list in Table 6 for the Ironton-Galesville or Table 7 for the Mt. Simon to document baseline fluid chemistry and to detect changes in fluid chemistry that could result from the movement of brine or CO₂ from the storage interval through the seal formation.

B.1.b Type and Number of Samples/Test Runs

Ground water sampling frequencies are detailed in Table 1.

B.1.c. Site/Sampling Locations

Shallow ground water monitoring will use existing wells IBDP G101, G102, G103, and G104 (Figure 3), and IL-ICCS-MVA 10LG, IL-ICCS-MVA 11LG, IL-ICCS-MVA 12LG, and IL-ICCS-MVA 13LG as noted in Section B.1.a. Deep ground water monitoring will use existing wells VW#1 and VW#2 (Figure 2) **Error! Reference source not found.** as noted in Section B.1.a.

B.1.d. Sampling Site Contingency

The shallow and deep ground water monitoring wells are located on property of the project participants (e.g., ADM, Richland Community College) and access permissions have already been granted. No problems of site inaccessibility are anticipated. If inclement weather makes site access difficult, sampling schedules will be reviewed and alternative dates may be selected that would still meet permit-related conditions.

B.1.e. Activity Schedule

The ground water sampling activities and frequencies are summarized in Table 1.

B.1.f. Critical/Informational Data

During both ground water sampling and analytical efforts, detailed field and laboratory documentation will be taken. Documentation will be recorded in field and laboratory forms and notebooks. Critical information will include time and date of activity, person/s performing activity, location of activity (well-field sampling) or instrument (lab analysis), field or laboratory instrument calibration data, field parameter values. For laboratory analyses, much of the critical data are generated during the analysis and provided to end users in digital and printed formats. Noncritical data may include appearance and odor of the sample, problems with well or sampling equipment, and weather conditions.

B.1.g. Sources of Variability

Potential sources of variability related to monitoring activities include (1) natural variation in fluid quality, formation pressure and temperature and seismic activity; (2) variation in fluid quality, formation pressure and temperature, and seismic activity due to project operations; (3) changes in recharge due to rainfall, drought, and snowfall; (4) changes in instrument calibration during sampling or analytical activity; (5) different staff collecting or analyzing samples; (6) differences in environmental conditions during field sampling activities; (7) changes in analytical data quality during life of project; and (8) data entry errors related to maintaining project database.

Activities to eliminate, reduce, or reconcile variability related to monitoring activities include (1) collecting long-term baseline data to observe and document natural variation in monitoring parameters,

(2) evaluating data in a timely manner after collection to observe anomalies in data that can be addressed by being resampled or reanalyzed, (3) conducting statistical analysis of monitoring data to determine whether variability in a data set is the result of project activities or natural variation, (4) maintaining weather-related data using on-site weather monitoring data or data collected near project site (such as from local airports), (5) checking instrument calibration before, during and after sampling or sample analysis, (6) thoroughly training staff, (7) conducting laboratory quality assurance checks using third party reference materials, and/or blind, and/or replicate sample checks, and (8) developing a systematic review process of data that can include sample-specific data quality checks (i.e., cation/anion balance for aqueous samples).

B.2. Sampling Methods

Logging, geophysical monitoring, and pressure/temperature monitoring do not apply to this section, and are omitted.

B.2.a/b. Sampling SOPs

Ground water samples will be collected primarily using a low-flow sampling method consistent with ASTM D6452-99 (2005) or Puls and Barcelona (1996). If a flow-through cell is not used, field parameters will be measured in grab samples. Ground water wells will be purged to ensure samples are representative of formation water quality. Static water levels in each well will be determined using an electronic water level indicator before any purging or sampling activities begin. Dedicated pumps (e.g., bladder pumps) will be installed in each monitoring well to minimize potential cross contamination between wells. Ground water pH, temperature, specific conductance, and dissolved oxygen will be monitored in the field using portable probes and a flow-through cell consistent with standard methods (e.g., APHA, 2005) given sufficient flow rates and volumes. Field chemistry probes will be calibrated at the beginning of each sampling day according to equipment manufacturer procedures using standard reference solutions. When a flow-through cell is used, field parameters will be continuously monitored and will be considered stable when three successive measurements made three minutes apart meet the criteria listed in Table 16.

Table 16. Stabilization criteria of water quality parameters during shallow well purging.

FIELD PARAMETER	STABILIZATION CRITERIA
pH	+/- 0.2 units
Temperature	+/- 1°C
Specific Conductance	+/- 3% of reading in $\mu\text{S}/\text{cm}$
Dissolved Oxygen	+/- 10% of reading or 0.3 mg/L whichever is greater

After field parameters have stabilized, samples will be collected. Samples requiring filtration will be filtered through 0.45 μm flow-through filter cartridges as appropriate and consistent with ASTM D6564-00. Prior to sample collection, filters will be purged with a minimum of 100 mL of well water (or more if required by the filter manufacturer). For alkalinity and total CO_2 samples, efforts will be made to minimize exposure to the atmosphere during filtration, collection in sample containers, and analysis.

For deep ground water sampling of VW#1, ISGS-SOP-WB-V1.14 (dated August 10, 2012) will be used for the collection and processing of samples. GM#1 will not have a similar installation for sampling and is anticipated to use a wireline sampling system with a sampling device (e.g., Kuster sampler or similar) capable of collecting a sample from a discrete interval. Samples from GM#1 will be processed in a manner consistent with ISGS-SOP-WB-V1.14.

VW#1 was developed and purged extensively at the time of completion. Prior to sampling, each zone will be purged to ensure representative samples are collected. Due to the extensive well development, the amount of fluid to be purged at the time of sampling will depend on the span of the sample interval. For VW#1, the annular volume between the 2-7/8 in. tubing and the 5-1/2 in. casing is approximately 0.64 gallons per foot of sampling interval. Thus, relatively small purge volumes will adequately refresh each isolated sampling interval. Additional information about sampling procedures at VW#1 is given in Locke et al. (2013).

For VW#2, it is anticipated that air lifting with nitrogen will be used to draw fluid into the well for purging. A gas lift valve will be placed in the tubing string at approximately 1,200 ft below ground surface at the time of the completion. The sampler will be positioned at the same elevation as the discrete perforated interval, and a sample would be collected after sufficient purging.

B.2.c. In-situ Monitoring.

In-situ monitoring of ground water chemistry parameters is not currently planned.

B.2.d. Continuous Monitoring.

Pressure data will be collected from shallow ground water wells on a periodic basis (e.g., hourly to daily) using dedicated pressure transducers with data loggers to generally characterize shallow water level trends. These data are informational only.

B.2.e. Sample Homogenization, Composition, Filtration.

Described in section B.2.b.

B.2.f. Sample Containers and Volumes

For shallow and deep ground water samples, all sample bottles will be new. Sample bottles and bags for analytes will be used as received (ready for use) from the vendor or contract analytical laboratory for the analyte of interest. A summary of sample containers is presented in Table 17.

B.2.g. Sample Preservation

For ground water and other aqueous samples, the preservation methods in Table 17 will be used.

B.2.h. Cleaning/Decontamination of Sampling Equipment

Dedicated pumps (e.g., bladder pumps) will be installed in each ground water monitoring well to minimize potential cross contamination between wells. These pumps will remain in each well throughout the project period except for maintenance. Prior to installation, the pumps will be cleaned on the outside with a non-phosphate detergent. Pumps will be rinsed a minimum of three times with deionized water and a minimum of 1 L of deionized water will be pumped through pump and sample tubing. Individual cleaned pumps and tubing will be placed in plastic garbage bags for transport to the field for installation. All field glassware (pipets, beakers, filter holders, etc.) are cleaned with tap water to remove any loose dirt, washed in a dilute nitric acid solution, and rinsed three times with deionized water before use.

B.2.i Support Facilities

For sampling of ground water, the following are required: air compressor, vacuum pump, generator, multi-electrode water quality sonde, analytical meters (pH, specific conductance, etc.). Field activities are usually completed in field vehicles and portable laboratory trailers located on site.

Field gauges will be removed from the injection well and verification well utilizing existing standard industry tools and equipment. Deployment and retrieval of verification well gauges will be done using procedures and equipment recommended by the vendor, subcontractor, or is standard per industry practice.

B.2.j. Corrective Action, Personnel, and Documentation

Field staff will be responsible for properly testing equipment and performing corrective actions on broken or malfunctioning field equipment. If corrective action cannot be taken in the field, then equipment will be returned to the manufacturer for repair or replaced. Significant corrective actions affecting analytical results will be documented in field notes.

B.3. Sample Handling and Custody

Logging, geophysical monitoring, and pressure/temperature monitoring does not apply to this section, and is omitted.

Sample holding times (Table 17) will be consistent with those described in US EPA (1974), American Public Health Association (APHA, 2005), Wood (1976), and ASTM Method D6517-00 (2005). After collection, samples will be placed in ice chests in the field and maintained thereafter at approximately 4°C until analysis. The samples will be maintained at their preservation temperature and sent to the designated laboratory within 24 hours. Analysis of the samples will be completed within the holding time listed in Table 17. As appropriate, alternative sample containers and preservation techniques approved by the UIC Program Director will be used to meet analytical requirements.

B.3.a Maximum Hold Time/Time Before Retrieval

See Table 17.

Table 17. Summary of anticipated sample containers, preservation treatments, and holding times.

Target Parameters	Volume/Container Material	Preservation Technique	Sample Holding Time	Relative Sampling Depth
Cations: Ca, Fe, K, Mg, Na, Si, Al, Ba, Mn, As, Cd, Cr, Cu, Pb, Sb Se, Tl	250 ml/HDPE	Filtered, nitric acid, cool 4°C	60 days	Shallow
Dissolved CO₂	2 × 60 ml/HDPE	Filtered, cool 4°C	14 days	Shallow
Dissolved CO₂	60 ml/HDPE	Filtered, cool 4°C	14 days	Deep
Isotopes δ ¹³ C of DIC	2 × 60 ml/HDPE	Filtered, cool 4°C	4 weeks	Shallow
Isotopes δ ¹³ C of DIC	60 ml/HDPE	Filtered, cool 4°C	4 weeks	Deep

Target Parameters	Volume/Container Material	Preservation Technique	Sample Holding Time	Relative Sampling Depth
Alkalinity, anions (Br, Cl, F, NO ₃ , SO ₄)	500 ml/HDPE	Filtered, cool 4°C	45 days	Shallow
Field Confirmation: Temperature, dissolved oxygen, specific conductance, pH	200 ml/glass jar	None	< 1 hour	Deep
Field Confirmation: Density	60 ml/HDPE	Filtered	< 1 hour	Deep

B.3.b. Sample Transportation

See description at the beginning of Section B.3.

B.3.c. Sampling Documentation

Field notes will be collected for all ground water samples collected. These forms will be retained and archived as reference. The sample documentation is the responsibility of ground water sampling personnel.

B.3.d. Sample Identification

All sample bottles will have waterproof labels with information denoting project, sampling date, sampling location, sample identification number, sample type (freshwater or brine), analyte, volume, filtration used (if any), and preservative used (if any). See Figure 4 for an example of a label.

IBDP_10LG_20A (fresh water)
01-23-2014
Metals, 60 ml, filtered, HNO₃

Figure 4. Example label for ground water sample bottles.

B.3.e. Sample Chain-of-Custody

For ground water samples, chain-of-custody will be documented using a standardized form. A typical form is shown in Figure 5, and it or a similar form will be used for all ground water sampling. Copies of the form will be provided to the person/lab receiving the samples as well as the person/lab transferring the samples. These forms will be retained and archived to allow simplified tracking of sample status. The chain-of -custody form and record keeping is the responsibility of ground water sampling personnel.



CHAIN OF CUSTODY RECORD (Page __ of __)

Illinois State Water Survey – Analytical Services Group
 Illinois State Geological Survey – Geochemistry Section

For Midwest Geological Sequestration Consortium (MGSC) Projects

	MGSC ID	ISGS MVA ID	Matrix	Date Collected	Time Collected	Sampling Team	Circle analyses to be performed
1							anions, cations, TDS, alk, NH ₃ , NVOC
2							anions, cations, TDS, alk, NH ₃ , NVOC
3							anions, cations, TDS, alk, NH ₃ , NVOC
4							anions, cations, TDS, alk, NH ₃ , NVOC
5							anions, cations, TDS, alk, NH ₃ , NVOC
6							anions, cations, TDS, alk, NH ₃ , NVOC
7							anions, cations, TDS, alk, NH ₃ , NVOC
8							anions, cations, TDS, alk, NH ₃ , NVOC
9							anions, cations, TDS, alk, NH ₃ , NVOC
10							anions, cations, TDS, alk, NH ₃ , NVOC
11							anions, cations, TDS, alk, NH ₃ , NVOC
12							anions, cations, TDS, alk, NH ₃ , NVOC
12							

CHAIN OF CUSTODY		
Relinquished by:	Print Name:	Date and Time:
Received by:	Print Name:	Date and Time:
General Remarks: - Field parameters are to be recorded on separate sheets by sampling teams. - Any special laboratory instructions or remarks should be made below.		
Data Contacts:	Fund:	
Billing Contact:	Billing Address:	
Send Data To:		

Remarks:

Rev. Oct. 2011 (RL)

Figure 5. Example chain-of-custody form.

B.4. Analytical Methods

Logging, geophysical monitoring, and pressure/temperature monitoring do not apply to this section, and are omitted.

B.4.a. Analytical SOPs

Analytical SOPs are referenced in Table 4–Table 7. Other laboratory specific SOPs utilized by the laboratory will be determined after a contract laboratory has been selected. Upon request ADM will provide the agency with all laboratory SOPs developed for the specific parameter using the appropriate standard method. Each laboratory technician conducting the analysis on the samples will be trained on the SOP developed for each standard method. ADM will include the technician’s training certification with the annual report.

B.4.b. Equipment/Instrumentation Needed

Equipment and instrumentation is specified in the individual analytical methods referenced in Table 4–Table 7.

B.4.c. Method Performance Criteria

Nonstandard method performance criteria are not anticipated for this project.

B.4.d. Analytical Failure

Each laboratory conducting the analyses in Table 4–Table 7 will be responsible for appropriately addressing analytical failure according to their individual SOPs.

B.4.e. Sample Disposal

Each laboratory conducting the analyses in in Table 4–Table 7 will be responsible for appropriate sample disposal according to their individual SOPs.

B.4.f Laboratory Turnaround

Laboratory turnaround will vary by laboratory, but generally turnaround of verified analytical results within one month will be suitable for project needs.

B.4.g. Method Validation for Nonstandard Methods

Nonstandard methods are not anticipated for this project. If nonstandard methods are needed or proposed in the future, the USEPA will be consulted on additional appropriate actions to be taken.

B.5. Quality Control

Geophysical monitoring and pressure/temperature monitoring does not apply to this section, and is omitted. For log quality control, please refer to Appendix B.

B.5.a. QC activities

Blanks

For shallow ground water sampling, a field blank will be collected and analyzed for the inorganic analytes in Table 4–Table 7 at a frequency of 10% or greater. Field blanks will be exposed to the same field and transport conditions as the ground water samples. Blanks will also be utilized for deep ground water sampling and analyzed for the inorganic analytes in Table 4–Table 7 at a frequency of 10% or

greater. Field blanks will be used to detect contamination resulting from the collection and transportation process.

Duplicates

For each shallow ground water sampling round, a duplicate ground water sample is collected from a well from a rotating schedule. Duplicate samples are collected from the same source immediately after the original sample in different sample containers and processed as all other samples. Duplicate samples are used to assess sample heterogeneity and analytical precision.

B.5.b. Exceeding Control Limits

If the sample analytical results exceed control limits (i.e., ion balances > ±10%), further examination of the analytical results will be done by evaluating the ratio of the measured total dissolved solids (TDS) to the calculated TDS (i.e., mass balance) per APHA method. The method indicates which ion analyses should be considered suspect based on the mass balance ratio. Suspect ion analyses are then reviewed in the context of historical data and interlaboratory results, if available. Suspect ion analyses are then brought to the attention of the analytical laboratory for confirmation and/or reanalysis. The ion balance is recalculated, and if the error is still not resolved, suspect data are identified and may be given less importance in data interpretations.

B.5.c. Calculating Applicable QC Statistics

Charge Balance

The analytical results are evaluated to determine correctness of analyses based on anion-cation charge balance calculation. Because all potable waters are electrically neutral, the chemical analyses should yield equally negative and positive ionic activity. The anion-cation charge balance will be calculated using the formula:

$$\% \text{ difference} = 100 \frac{\sum \text{cations} - \sum \text{anions}}{\sum \text{cations} + \sum \text{anions}} \quad (\text{Equation 1})$$

where the sums of the ions are represented in milliequivalents (meq) per liter and the criteria for acceptable charge balance is ±10%.

Mass Balance

The ratio of the measured TDS to the calculated TDS will be calculated in instances where the charge balance acceptance criteria are exceeded using the formula:

$$1.0 < \frac{\text{measured TDS}}{\text{calculated TDS}} < 1.2 \quad (\text{Equation 2})$$

where the anticipated values are between 1.0 and 1.2.

Outliers

A determination of one or more statistical outliers is essential prior to the statistical evaluation of ground water. This project will use the USEPA's Unified Guidance (March 2009) as a basis for selection of recommended statistical methods to identify outliers in ground water chemistry data sets as appropriate. These techniques include Probability Plots, Box Plots, Dixon's test, and Rosner's test. The EPA-1989 outlier test may also be used as another screening tool to identify potential outliers.

B.6. Instrument/Equipment Testing, Inspection, and Maintenance

Logging tool equipment will be maintained as per wireline industry best practices (Appendix B).

For ground water sampling, field equipment will be maintained, factory serviced, and factory calibrated per manufacturer's recommendations. Spare parts that may be needed during sampling will be included in supplies on-hand during field sampling.

For all laboratory equipment, testing, inspection and maintenance will be the responsibility of the analytical laboratory per standard practice, method-specific protocol, or NELAP requirement.

B.7. Instrument/Equipment Calibration and Frequency

Geophysical monitoring does not apply to this section, and is omitted.

B.7.a. Calibration and Frequency of Calibration

Pressure/temperature gauge calibration information is located in Table 10–Table 15. Logging tool calibration will be at the discretion of the service company providing the equipment, following standard industry practices noted in Appendix B. Calibration frequency will be determined by standard industry practices.

For ground water sampling, portable field meters or multiprobe sondes used to determine field parameters (e.g., pH, temperature, specific conductance, dissolved oxygen) are calibrated according to manufacturer recommendations and equipment manuals (Hach, 2006) each day before sample collection begins. Recalibration is performed if any components yield atypical values or fail to stabilize during sampling.

B.7.b. Calibration Methodology

Logging tool calibration methodology will follow standard industry practices in Appendix B.

For ground water sampling, standards used for calibration are typically 7 and 10 for pH, a potassium chloride solution yielding a value of 1413 microseimens per centimeter ($\mu\text{S}/\text{cm}$) at 25°C for specific conductance, and a 100% dissolved O_2 solution for dissolved oxygen. Calibration is performed for the pH meters per manufacturer's specifications using a 2-point calibration bounding the range of the sample. For coulometry, sodium carbonate standards (typically yielding a concentration of 4,000 mg CO_2/L) are routinely analyzed to evaluate instrument.

B.7.c. Calibration Resolution and Documentation

Logging tool calibration resolution and documentation will follow standard industry practices in Appendix B.

For ground water sampling, calibration values are recorded in daily sampling records and any errors in calibration are noted. For parameters where calibration is not acceptable, redundant equipment may be used so loss of data is minimized.

B.8. Inspection/Acceptance for Supplies and Consumables

B.8.a/b. Supplies, Consumables, and Responsibilities

Supplies and consumables for field and laboratory operations will be procured, inspected, and accepted as required from vendors approved by ADM or the respective subcontractor responsible for the data

collection activity. Acquisition of supplies and consumables related to ground water analyses will be the responsibility of the laboratory per established standard methodology or operating procedures.

B.9. Nondirect Measurements

Seismic Monitoring Methods

B.9.a Data Sources

For time lapse seismic surveys, repeatability is paramount for accurate differential comparison. Therefore, to ensure survey quality, the locations for the shots and acquisition methodology of sequential surveys will be consistent. Once these surveys are conducted, they will be compared to a baseline survey to track and monitor plume development.

For in-zone pressure monitoring, the in-zone pressure gauges in VW#1 and VW#2 will be used to gather pressure data.

B.9.b. Relevance to Project

Time lapse seismic surveys will be used to track changes in the CO₂ plume in the subsurface. Processing and comparing subsequent surveys to a baseline will allow project managers to monitor plume growth, as well as to ensure that the plume does not move outside of the intended storage reservoir. Numerical modeling will be used to predict the CO₂ plume growth and migration over time by combining the processed seismic data with the existing geologic model.

In-zone pressure monitoring data will be used in numerical modeling to predict plume and pressure front behavior and confirm the plume stage within the AoR.

B.9.c. Acceptance Criteria

Following standard industry practices will ensure that the gathered seismic data will be used for accurate modeling and monitoring. Similar ground conditions, shot points located within tolerable limits, functional geophones, and similar seismic input signal will be used from survey to survey to ensure repeatability.

When processing seismic data, several QA checks will be done in accordance with industry standards including reformatting to Omega structured files, geometry application, amplitude compensation, predictive deconvolution, elevation statics correction, RMS amplitude gain, velocity analysis every 2 km, NMO application using picked velocities, CMP stacking, random noise attenuation, and instantaneous gain.

B.9.d. Resources/Facilities Needed

ADM will subcontract all necessary resources and facilities for the seismic monitoring, in-zone pressure monitoring, and ground water sampling.

B.9.e. Validity Limits and Operating Conditions

For seismic surveys and numerical modeling, intraorganizational checks between trained and experienced personnel will ensure that all surveys and numerical modeling are conducted conforming to standard industry practices.

B.10. Data Management

B.10.a. Data Management Scheme

ADM or a designated contractor will maintain the required project data as provided elsewhere in the permit. Data will be backed up on tape or held on secure servers.

B.10.b. Record-keeping and Tracking Practices

All records of gathered data will be securely held and properly labeled for auditing purposes.

B.10.c. Data Handling Equipment/Procedures

All equipment used to store data will be properly maintained and operated according to proper industry techniques. ADM SCADA system and vendor data acquisition systems will interface with one another and all subsequent data will be held on a secure server.

B.10.d. Responsibility

The primary project managers will be responsible for ensuring proper data management is maintained.

B.10.e. Data Archival and Retrieval

All data will be held by ADM. These data will be maintained and stored for auditing purposes as described in section B.10.a.

B.10.f. Hardware and Software Configurations

All ADM and vendor hardware and software configurations will be appropriately interfaced.

B.10.g. Checklists and Forms

Checklists and forms will be procured and generated as necessary.

C. Assessment and Oversight

C.1. Assessments and Response Actions

C.1.a. Activities to be Conducted

Please refer to Table 1 in section A.3.a/b. (Summary of work to be performed and work schedule); ground water quality data will be collected at the frequency outlined in that table. After completion of sample analysis, results will be reviewed for QC criteria as noted in section B.5. If the data quality fails to meet criteria set in section B.5., samples will be reanalyzed, if still within holding time criteria. If outside of holding time criteria, additional samples may be collected or sample results may be excluded from data evaluations and interpretations. Evaluation for data consistency will be performed according to procedures described in the USEPA 2009 Unified Guidance (USEPA, 2009).

C.1.b. Responsibility for Conducting Assessments

Organizations gathering data will be responsible for conducting their internal assessments. All stop work orders will be handled internally within individual organizations.

C.1.c. Assessment Reporting

All assessment information should be reported to the individual organization's project manager outlined in A.1.a/b.

C.1.d. Corrective Action

All corrective action affecting only an individual organization's data collection responsibility should be addressed, verified, and documented by the individual project managers and communicated to the other project managers as necessary. Corrective actions affecting multiple organizations should be addressed by all members of the project leadership and communicated to other members on the distribution list for the QASP. Assessments may require integration of information from multiple monitoring sources across organizations (operational, in-zone monitoring, above-zone monitoring) to determine whether correction actions are required and/or the most cost-efficient and effective action to implement. ADM will coordinate multiorganization assessments and corrective actions as warranted.

C.2. Reports to Management

C.2.a/b. QA status Reports

QA status reports should not be needed. If any testing or monitoring techniques are changed, the QASP will be reviewed and updated as appropriate in consultation with USEPA. Revised QASPs will be distributed by ADM to the full distribution list at the beginning of this document.

D. Data Validation and Usability

D.1. Data Review, Verification, and Validation

D.1.a. Criteria for Accepting, Rejecting, or Qualifying Data

Ground water quality data validation will include the review of the concentration units, sample holding times, and the review of duplicate, blank and other appropriate QA/QC results. All ground water quality results will be entered into a database or spreadsheet with periodic data review and analysis. ADM will retain copies of the laboratory analytical test results and/or reports. Analytical results will be reported on a frequency based on the approved UIC permit conditions. In the periodic reports, data will be presented in graphical and tabular formats as appropriate to characterize general ground water quality and identify intrawell variability with time. After sufficient data have been collected, additional methods, such as those described in the USEPA 2009 Unified Guidance (USEPA, 2009), will be used to evaluate intrawell variations for ground water constituents, to evaluate if significant changes have occurred that could be the result of CO₂ or brine seepage beyond the intended storage reservoir.

D.2. Verification and Validation Methods

D.2.a. Data Verification and Validation Processes

See sections D.1.a. and B.5.

Appropriate statistical software will be used to determine data consistency.

D.2.b. Data Verification and Validation Responsibility

ADM or its designated subcontractor will verify and validate ground water sampling data.

D.2.c. Issue Resolution Process and Responsibility

ADM or its designated Coordinator will overview the ground water data handling, management, and assessment process. Staff involved in these processes will consult with the Coordinator to determine actions required to resolve issues.

D.2.d. Checklist, Forms, and Calculations

Checklists and forms will be developed specifically to meet permit requirements. Table 18 provides an example of the type of information used for data verification of ground water quality data.

Table 18. Example table of criteria used to evaluate data quality.

MVA ID	Anion charge	Cation charge	Charge balance	CB rating	Calculated TDS	Measured TDS	TDS ratio	TDS rating
IBDP_10B_01A	14.4	13.60	-2.84	pass	760.50	785	1.0	pass
IBDP_10B_02A	14.26	15.06	2.73	pass	783.03	777	1.0	pass
IBDP_10B_03A	14.39	14.96	1.94	pass	786.86	806	1.0	pass
IBDP_10B_04A	14.39	14.79	1.38	pass	780.15	777	1.0	pass
IBDP_10B_04B	14.33	14.90	1.96	pass	780.95	785	1.0	pass

D.3. Reconciliation with User Requirements

D.3.a. Evaluation of Data Uncertainty

Statistical software will be used to determine ground water data consistency using methods consistent with USEPA 2009 Unified Guidance (USEPA, 2009).

D.3.b. Data Limitations Reporting

The organization-level project managers will be responsible for ensuring that data developed by their respective organizations is presented with the appropriate data-use limitations.

ADM will use the current operating procedure on the use, sharing, and presentation of results and/or data for the IBDP. This procedure has been developed to ensure quality, internal consistency and facilitate tracking and record keeping of data end users and associated publications.

References

- APHA, 2005, *Standard methods for the examination of water and wastewater (21st edition)*, American Public Health Association, Washington, DC.
- ASTM, 2005, Method D6517-00 (reapproved 2005), *Standard guide for field preservation of ground-water samples*, ASTM International, 100 Barr Harbor Drive, West Conshohocken, PA.
- ASTM, 2005, Method D6564-00 (reapproved 2005), *Standard guide for field filtration of ground-water samples*, ASTM International, 100 Barr Harbor Drive, West Conshohocken, PA.
- ASTM, 2005, Method D6452-99 (reapproved 2005), *Standard Guide for Purging Methods for Wells Used for Ground-Water Quality Investigations*, ASTM International, 100 Barr Harbor Drive, West Conshohocken, PA.
- ASTM, 2002, Method D513-11, *Standard test methods for total and dissolved carbon dioxide in water*, ASTM International, 100 Barr Harbor Drive, West Conshohocken, PA.
- Hach Company, February 2006, *Hydrolab DS5X, DS5, and MS5 Water Quality Multiprobes User Manual*, Hach Company, 73 p.
- Locke II, R., D. Larssen, W. Salden, C. Patterson, J. Kirksey, A. Iranmanesh, B. Wimmer, I. Krapac. *Preinjection reservoir fluid characterization at a CCS demonstration site: Illinois Basin – Decatur Project, USA*. Proceedings of the 11th International Conference on Greenhouse Gas Technologies, November 18–22, 2012, Kyoto, Japan. *Energy Procedia* v. 37, 2013, p. 6,424–6,433.
<http://dx.doi.org/10.1016/j.egypro.2013.06.572>
- Puls, R.W., and M.J. Barcelona, 1996, *Low-Flow (Minimal Drawdown) Ground-Water Sampling Procedures*. U.S. Environmental Protection Agency, EPA-540/S-95/504.
- U.S. Environmental Protection Agency (USEPA), 2009, *Statistical analysis of groundwater monitoring data at RCRA facilities—Unified Guidance*, US EPA, Office of Solid Waste, Washington, DC.
- U.S. Environmental Protection Agency (USEPA), 1974, *Methods for chemical analysis of water and wastes*, US EPA Cincinnati, OH, EPA-625-/6-74-003a.
- Wood, W.W., 1976, *Guidelines for collection and field analysis of groundwater samples for selected unstable constituents*, In U.S. Geological Survey, *Techniques for Water Resources Investigations*, Chapter D-2, 24 p.

Appendices

APPENDIX A. DTS and Down-hole Pressure Gauge Information

WellWatcher Ultra

Distributed Temperature System

APPLICATIONS

- Distributed temperature measurements
- Control of production rates and drawdown
- Monitoring
 - Reservoir flow contributions and decline
 - Gas lift optimization and tubing integrity
 - Heavy oil thermal recovery
- Production allocation
- Injection profiling
- Gas lift optimization
- Riser flow assurance

FEATURES

- Fiber-optic distributed temperature sensing technology
- No downhole electronics
- Simple-to-use surface software, with auto-setup and optimization
- Reliable, robust instrument and extended system life
- Best-in-class measurements
 - Fast temperature resolution
 - 15-km [9.32-m] range, 6 doubled-ended or 12 single-ended channel interrogation

The WellWatcher Ultra* distributed temperature system provides detailed information related to a reservoir's performance through the acquisition of temperature profiles. The extremely versatile system can measure up to 15 km [9.32 mi] of fiber at a meter's resolution, update data in just a few seconds, resolve temperatures to 0.01 degC [0.018 degF], and interrogate numerous fibers from one surface system. The data obtained are available as soon as the measurement is taken. They are communicated via various industry-standard protocols or those customized by Schlumberger's engineering team to the specifics of a particular installation. The data are combinable with data obtained by other Schlumberger sensors, and experts are available to help design the best solution for a particular situation.

ACQUISITION RESULTS

Distributed temperature sensing (DTS) acquisition is configured based on the application. This configuration is typically made up of a combination of profiles, zones, and real-time alarms. Profiles include temperature measurements taken at regular intervals along the fiber. This information can be used to measure reservoir performance and to monitor completion integrity, thereby helping ensure downstream flow. Zonal areas of interest can be specified to facilitate real-time monitoring in SCADA systems and to trigger alarms for critical indicators.

DTS DATA HANDLING

Profile data are temperature measurement profiles of the entire fiber cable consisting of a series of data points. Zone data are statistical data from a particular specified section of the fiber, processed according to specification. Alarm data trigger a signal according to specifications.

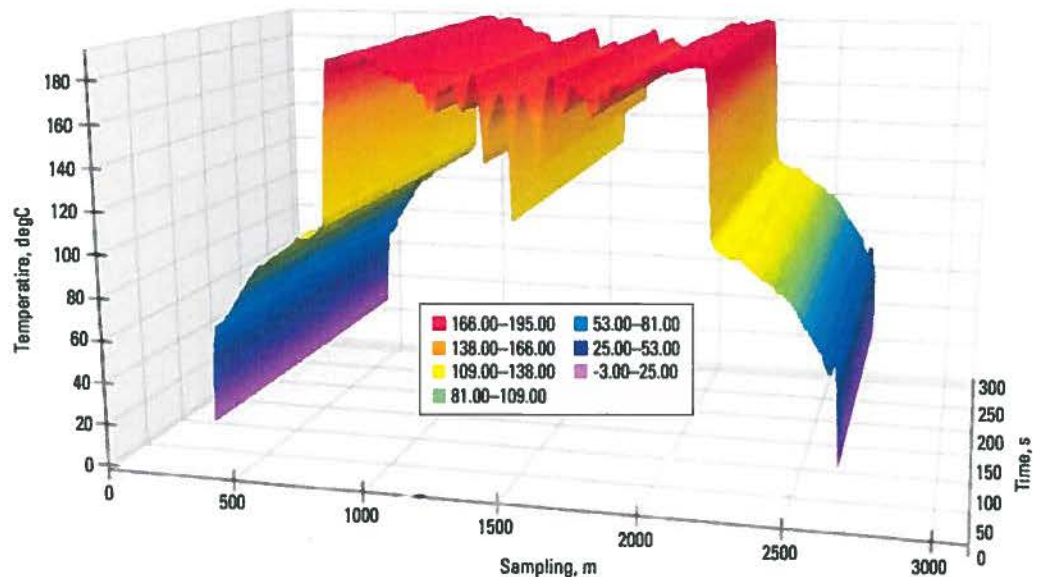

In a heavy oil steam injector, the fiber is connected to the acquisition unit at both ends (for a double-ended configuration) to provide a completely compensated correction for any losses in the fiber. This arrangement helps ensure the maximum life for the monitoring system in this aggressive working environment.

WellWatcher Ultra Distributed Temperature System

BENEFITS

- Permanent in-well reservoir monitoring
- Enhanced recovery through improved reservoir surveillance
- Improved production management
- Faster identification of production problems through best-in-class temperature resolution
- Cost-effective transient analysis
 - Fewer interventions
 - Improved optics, allowing fiber logging for a longer time, increasing system life
- Improved reliability and accuracy for high-temperature monitoring systems

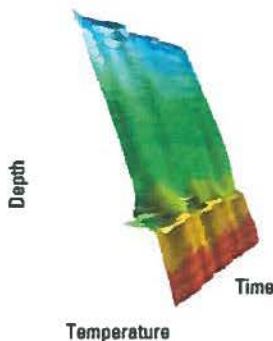

In a gas injection well with a slugging injection valve, distributed temperature measurements can quickly identify a problem valve, saving time during valve replacement and minimizing lost production.

IT INTEGRATION

The WellWatcher Ultra DTS acquisition unit has a robust database that stores all acquired data on site with local backup. In addition, various technologies are available to integrate the data seamlessly into any IT environment. Industry-standard technologies such as the Modbus communication protocol, OPC open connectivity, wellsite information transfer standard markup language (WITSML), and SQL database replication can be used to deliver the data in real time to SCADA systems, data historians, the Schlumberger InterACT® real-time monitoring and data delivery secure Web service, or simply to Microsoft Excel® software on a personal computer.

IT INTEGRATION SUCCESS

A Schlumberger client had a fiber-optic DTS installed in a production field and wanted to integrate the data into its IT environment. The client wanted the data stored and viewable locally but required that the information be quickly accessible from the main office. With the WellWatcher Ultra DTS acquisition unit, the well profiles could be stored locally, the WITSML files provided locally for quick retrieval, and the data uploaded into the reservoir management system. Modbus output provided basic system alarms linked directly to the local control room to help ensure asset integrity.

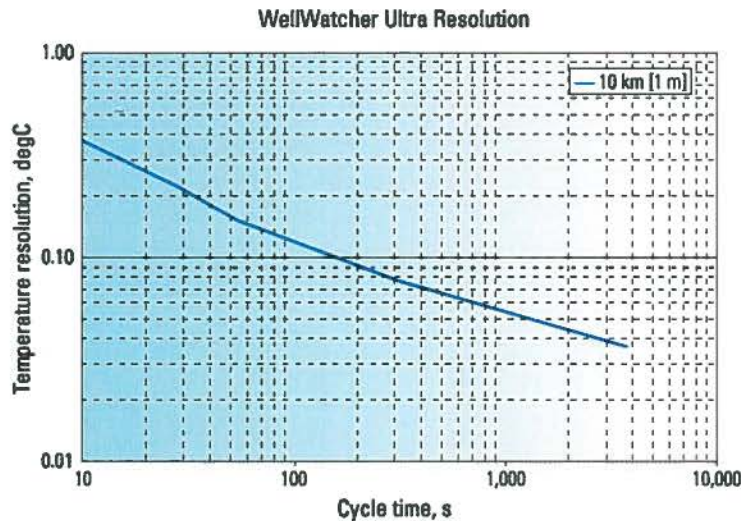

The log/log metrology plot shows the time required for a typical WellWatcher Ultra DTS acquisition unit out of calibration to reach certain temperature resolutions for 10 km of fiber. Additional optimization is possible to further improve results, depending on the application requirements.

Specifications

Range, km [mi]	15 [9.32]
Spatial resolution, m [ft]	1–4 [3.3–13.1]
Sample interval, m [ft]	0.5–2 [1.64–6.56]
Calibration accuracy, degC [degF]	±0.5 [±0.9] at (0–8 km); ±1 [±1.8] at (8–12 km)
Number of loops or fibers	6 double-ended or 12 single-ended
Fiber type	50 µm, multimode
DTS physical dimensions	3U 19-in, rack mounted or mobile
Operating temperature, degC [degF]	0 to 40 [32 to 104]
Storage temperature, degC [degF]	–20 to 65 [–4 to 149]
Relative humidity, %	5–85 (noncondensing)
Power	AC, 90–253 V (optional DC, 24 V); Typical steady state: 50 W; maximum: 150 W
DTS communications	
DTS to PC	Ethernet 100/1000 Base T
DTS to Modbus PLC	Ethernet 10/100 Base T
Relay contact: 32 per box	RS485
Laser classification	Class 1m, (IEC/EN 60825-1 [2001])

www.slb.com/completions

Schlumberger

WellWatcher Quartz

NLQG, NMQG, NPQG, NHQG multidrop pressure and temperature gauges

APPLICATIONS

- Long-term production and reservoir monitoring
- Pressure buildup surveys
- Injection monitoring
- Intelligent completions

BENEFITS

- Saves costs of well intervention by taking continuous pressure and temperature measurements

FEATURES

- Long-term measurement accuracy with excellent sensor and electronic stability
- High system reliability confirmed by rigorous testing
- Long-term, reliable, permanent in-well reservoir monitoring
- Compact gauge design for optimal well integration
- Gauge system with advanced cable connector technology
- Multiple-gauge installation on a single cable with standard 1-s sampling rate
- Compatibility with the WellWatcher Neon[®] electro-optical cable system for combined distributed temperature-sensing measurements
- Flow rate and fluid density measurements in specific applications
- Hermetically sealed gauge housing, fully welded with inert gas filling
- Availability of IWIS-compliant and vendor-specific subsea cards

WellWatcher Quartz[®] NLQG, NMQG, NPQG, and NHQG multidrop pressure and temperature gauges are part of the WellWatcher[®] permanent real-time downhole monitoring system. WellWatcher systems help operators optimize well productivity and reservoir recovery throughout the producing life of a well or field.

Schlumberger has installed more than 7,000 permanent downhole pressure and temperature gauges over the past 25 years and has established numerous engineering and performance benchmarks for downhole monitoring. Continual performance improvement has yielded the most reliable track record in the industry for these types of gauges.

The latest-generation Schlumberger permanent WellWatcher Quartz gauges continue this tradition and incorporate the most recent innovations in quartz transducers, advanced electronic components, and cable head connector sealing technology.

DATA QUALITY

Accurate and stable pressure measurements are essential in long-term reservoir and production monitoring applications. Schlumberger permanent WellWatcher Quartz gauges are engineered to deliver highly stable pressure measurements for long-term applications.

Performance is validated in a controlled test cell where drift stability is measured at simulated reservoir pressure and temperature conditions—not just at ambient temperature and atmospheric conditions.

During this measurement period, the gauges are also subjected to power on-off cycles and temperature cycling to simulate the most demanding operating conditions. The NPQG gauge is qualified for a 10-year life cycle and has a measured drift stability better than ± 7 kPa at 82,740 kPa and 150 degC [± 1 psi at 12,000 psi and 302 degF].

QUALIFICATION TESTING

The gauge system undergoes accelerated testing at 200 degC [392 degF] for about 8 months, in addition to thermal shock cycle testing. This test is equivalent to a 10-year life at 150 degC [302 degF]. The complete gauge assemblies also undergo repeated shock and vibration testing at rigorous levels to meet the environmental qualification for well testing in production and injection wells.

DESIGNED FOR RELIABILITY

The long-term reliability of the WellWatcher Quartz gauges relies on designs including fully welded assemblies, multichip module ceramic high-temperature electronic technology, and corrosion-resistant alloys.

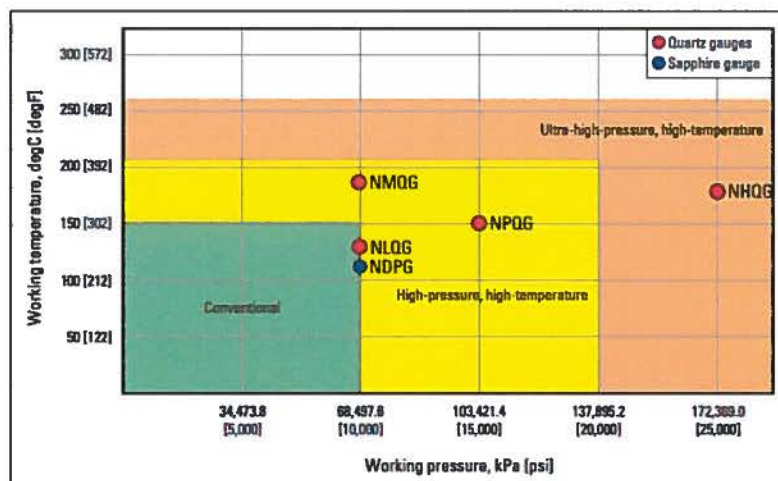

Temperature and pressure environmental applications in which WellWatcher Quartz and WellWatcher Sapphire[®] gauges are most appropriate.

WellWatcher Quartz

Also furthering the gauge technology is the excellent reliability at system level achieved with the Schlumberger proprietary advanced connector technology.

The standard NMQG (68,947 kPa [10,000 psi]), NPQG (110,320 kPa [16,000 psi]), and NHQG (172,375 kPa [25,000 psi]) gauges feature the innovative and fully field-proven Intellitite® electrical dry-mate cable head connector options. The welded cable head, which can be deployed even in Zone 1, delivers the best system protection against corrosive liquids, shock, vibration, and tensile load. The nonwelded cable head provides three independent seals, including two fully redundant metal-to-metal seals, and is fully pressure testable using a microleak detection system. Both cable head connector options deliver significant reliability improvement over industry-standard connectors.

The standard NLQG (10,000-psi) gauge is equipped with the Sealtite® connector, providing two independent seals, including an improved metal-to-metal seal. When dictated by demanding downhole conditions such as sour fluids or below-packer applications, the gauge is equipped with the Intellitite electrical dry-mate connector for an incremental level of reliability.

WORLDWIDE QUALITY SERVICE

WellWatcher systems are supported and deployed by a specialized group of engineers and technicians highly trained on permanent monitoring systems and intelligent completion technology. This specific central support for project preparation and operations contributes to delivering best-in-class service quality worldwide.

WellWatcher Quartz Gauge Specifications

	NLQG Light Quartz Gauge	NMQG Median Quartz Gauge	NPQG Pressure Quartz Gauge	NHQG Hyper Quartz Gauge
Sensor metrological performance				
Sensor type	Quartz	Quartz	Quartz	Quartz
Calibrated working pressure range, kPa [psi]	Atmospheric to 68,947 [10,000]	Atmospheric to 68,947 [10,000]	Atmospheric to 110,320 [16,000]	Atmospheric to 172,375 [25,000]
Calibrated working temperature range, degC [degF]	25 to 130 [77 to 266]	25 to 177 [68 to 350]	25 to 150 [68 to 302]	25 to 177 [68 to 350]
Other calibrated ranges ¹	Available upon request	Available upon request	Available upon request	Available upon request
Initial pressure accuracy, kPa [psi]	<±13.8 [±2] max. over full scale	<±13.8 [±2] max. over full scale	<±20.7 [±3] max. over full scale	<±34.5 [±5] max. over full scale
Pressure resolution, kPa [psi]	0.03 [0.005] at 1-s sample rate	0.03 [0.005] at 1-s sample rate	0.07 [0.01] at 1-s sample rate	0.14 [0.02] at 1-s sample rate
Pressure drift stability, kPa [psi]	<± 6.9 [±1] per year over full scale	<± 6.9 [±1] per year over full scale	<±6.9 [±1] per year at 82,740 kPa [12,000 psi] and 150 degC [302 degF]	<±6.9 [±1] per year at 82,740 kPa [12,000 psi] and 150 degC [302 degF]
Initial temperature accuracy, max., degC [degF]/typical degC [degF]	<±0.5 [±0.9] per ±0.15 [±0.27]	<±0.5 [±0.9] per ±0.15 [±0.27]	<±0.5 [±0.9] per ±0.15 [±0.27]	<±0.5 [±0.9] per ±0.15 [±0.27]
Temperature resolution, degC [degF]	0.005 [0.009] at 1-s sample rate	0.001 [0.002] at 1-s sample rate	0.001 [0.002] at 1-s sample rate	0.001 [0.002] at 1-s sample rate
Temperature drift stability, degC [degF]	<±0.1 [±0.18] per year at 150 [302]	<±0.1 [±0.18] per year at 177 [350]	<±0.1 [±0.18] per year at 150 [302]	<±0.1 [±0.18] per year at 177 [350]
Max. overtemperature, degC [degF]	150 [302]	200 [392]	200 [392]	200 [392]
Physical characteristics				
Max. housing diameter, mm [in]	19 [0.75]	19 [0.75]	19 [0.75]	19 [0.75]
Cable head connector options				
Intellitite R: true redundant metal/metal seal	Special request	Yes	Yes	Yes
Intellitite W: fully welded	na ²	Yes	Yes	Yes
Sealtite: metal/metal seal	Yes	na	na	na
Multigauge connections options	Fully welded Y, T, and W connector block assembly	Fully welded Y, T, and W connector block assembly	Fully welded Y, T, and W gauge assembly	Fully welded Y, T, and W gauge assembly
Gauge pressure port reading options	Tubing measurement, annulus measurement, measurement through control line by HDMC hydraulic connector, and flowmeter application			
Material	Corrosion-resistant alloys per ISO 15156 [with Intellitite connector option]	Corrosion-resistant alloys per ISO 15156	Corrosion-resistant alloys per ISO 15156	Corrosion-resistant alloys per ISO 15156
Service	H ₂ S (with Intellitite connector option)	H ₂ S	H ₂ S	H ₂ S
Collapse pressure, kPa [psi]	75,842 [11,000]	75,842 [11,000]	137,900 [20,000]	189,613 [27,500]
Storage and shipping temperature, degC [degF]	-40 to 75 [-40 to 167]	-40 to 75 [-40 to 167]	-40 to 75 [-40 to 167]	-40 to 75 [-40 to 167]
Well integration				
Max. number of gauges per single cable ³	4 at 1-s sampling rate			
Max. cable length, m [ft]	10,000 [32,800]			
Max. distance between gauges, m [ft]	1,000 [3,281]			
Qualification test data				
Long-term qualification test equivalent life cycle	10 years at 82,740 kPa [12,000 psi] and 150 degC [302 degF]			
Vibration	10 to 2,000 Hz at up to 4 g in any axis			
Shock	400 impacts at 250 g [2-ms half sine, 4 axis] and 6 drop impacts at 500 g [2-ms half sine, 6 axis]			

¹ A lower temperature calibration may be required for injection wells.

² Not applicable.

³ Consult a Schlumberger representative for additional specifications.

www.slb.com/completions

Schlumberger

APPENDIX B. Log Quality Control Reference Manual (LQCRM)

Wireline Log Quality Control Reference Manual

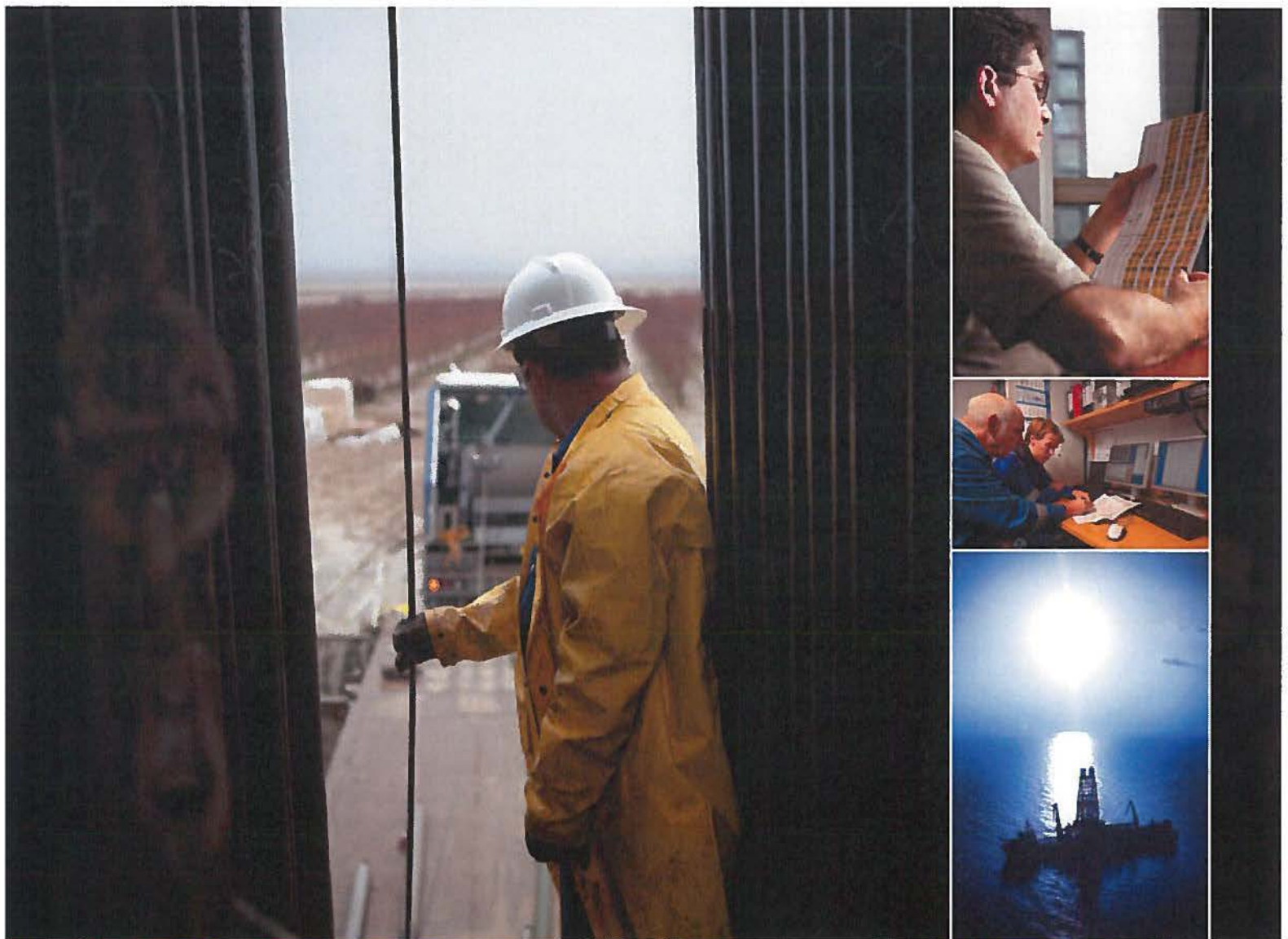

**Wireline Log
Quality Control
Reference Manual**

Schlumberger
3750 Briarpark Drive
Houston, Texas 77042

www.slb.com

Produced by Schlumberger Oilfield Marketing Communications

Copyright © 2012 Schlumberger. All rights reserved.

No part of this book may be reproduced, stored in a retrieval system, or transcribed in any form or by any means, electronic or mechanical, including photocopying and recording, without the prior written permission of the publisher.

While the information presented herein is believed to be accurate, it is provided "as is" without express or implied warranty.

11-FE-0131

An asterisk (*) is used throughout this document to denote a mark of Schlumberger. Other company, product, and service names are the properties of their respective owners.

Contents

Foreword	1
Introduction.....	2
Depth Control and Measurement.....	5
Logging Platforms and Suites	13
Platform Express* integrated wireline logging tool	13
PS Platform* production services platform	23
Dielectric Scanner	24
Dielectric Scanner* multifrequency dielectric dispersion service	24
EPT* electromagnetic propagation tool	29
Resistivity Logging	32
Rt Scanner* triaxial induction service	32
AIT* array induction imager tool	41
ARI* azimuthal resistivity imager	47
HRLA* high-resolution laterolog array	50
High-Resolution Azimuthal Laterolog Sonde	55
MicroSFL* spherically focused resistivity tool	60
Microlog	62
CHFR-Plus* and CHFR Slim* cased hole formation resistivity tools	64
Nuclear Measurements	67
Gamma Ray Tools	67
NGS* natural gamma ray spectrometry tool.....	69
Hostile Environment Natural Gamma Ray Sonde	71
ECS* elemental capture spectroscopy sonde.....	74
CNL* compensated neutron log	81
APS* accelerator porosity sonde	84
RST* and RSTPro* reservoir saturation tools	87
Litho-Density* photoelectric density log.....	92
Litho-Density Sonde	94
HLDT* hostile environment Litho-Density tool	97
SlimXtreme* LithoDensity tool.....	100
Nuclear Magnetic Resonance Logging.....	103
MR Scanner* expert magnetic resonance service.....	103
CMR-Plus* combinable magnetic resonance tool	107
Acoustic Logging	112
Sonic Scanner* acoustic scanning platform	112
Borehole-Compensated Sonic	117
Sonic Long Spacing	121
DSI* dipole shear sonic imager	124

Dipmeter and Imaging Services	129
FMI* fullbore formation microimager	129
FMI-HD* high-definition formation microimager	132
UBI* ultrasonic borehole imager	135
OBMI* oil-base microimager	139
Drilling and Directional Services	142
GPIT* General Purpose Inclination Tool	142
Seismic Imaging Tools and Services	145
CSI* combinable seismic imager	145
VSI* versatile seismic imager	148
Formation Testing and Sampling	154
MDT* modular formation dynamics tester	154
Quicksilver Probe* focused extraction of pure reservoir fluid	159
InSitu Fluid Analyzer* real-time quantitative reservoir fluid measurements	163
MDT Dual-Packer Module	169
MDT Dual-Probe Module	172
MDT Pumpout Module	175
LFA* live fluid analyzer	177
CFA* composition fluid analyzer	181
MDT Multisample Module	184
PressureXpress* reservoir pressure while logging service	186
SRFT* slimhole repeat formation tester	190
CHDT* cased hole dynamics tester	194
MSCT* mechanical sidewall coring tool	198
CST* chronological sample taker	200
Well Integrity Evaluation	203
Isolation Scanner* cement evaluation service	203
Cement bond tool	208
Cement bond logging with Slim Array Sonic Tool, Digital Sonic Logging Tool, and SlimXtreme tool	212
Sonic Scanner* acoustic scanning platform	215
SCMT* slim cement mapping tool	218
USI* ultrasonic imager	222
UCI* ultrasonic casing imager	225
METT* multifrequency electromagnetic thickness tool	228
Multifinger Caliper Tool	230
PS Platform Multifinger Imaging Tool	232
Production Logging Services	235
Flow Scanner* horizontal and deviated well production logging system	235
PS Platform production services platform	239
Platform Basic Measurement Sonde	240
Gradiomanometer* sonde	241
PS Platform Inline Spinner	243
Flow-Caliper Imaging Sonde	244

Digital Entry and Fluid Imager Tool	246
GHOST* gas holdup optical sensor tool	247
RST and RSTPro reservoir saturation tools	249
WFL* water flow log	254
TPHL* three-phase fluid production log	256
CPLT* combinable production logging tool	258
Perforating Services and Accessories	263
Perforating depth control	263
Plugs and Packers	265
PosiSet* mechanical plugback tool	265
Auxiliary Measurements and Devices	267
Borehole geometry log	267
Powered Positioning Device and Caliper	269
Auxiliary Measurement Sonde	271
Environmental Measurement Sonde	273
FPIT* free-point indicator tool	275
TDT* thermal decay time	277

Foreword

The certification of acquired data is an important aspect of logging. It is performed through the observation of quality indicators and can be completed successfully only when a set of specified requirements is available to the log users.

This Log Quality Control Reference Manual (LQCRM) is the third edition of the log quality control specifications used by Schlumberger. It concisely provides information for the acquisition of high-quality data at the wellsite and its delivery within defined standards. The LQCRM is distributed to facilitate the validation of Schlumberger wireline logs at the wellsite or in the office.

Because the measurements are performed downhole in an environment that cannot be exhaustively described, Schlumberger cannot and does not warrant the accuracy, correctness, or completeness of log data.

Large variations in well conditions require flexibility in logging procedures. In some cases, important deviations from the guidelines given here may occur. These deviations may not affect the validity of the data collected, but they could reduce the ability to check that validity.

Catherine MacGregor
President, Wireline

Introduction

Data is a permanent asset of energy companies that may be used in unforeseen ways. Schlumberger is committed to and accountable for managing and delivering quality data. The quality of the data is the cornerstone of Schlumberger products and services.

Data quality

Quality is conformance to predefined standards with minimum variation. This document defines the standards by which the quality of the data of Schlumberger wireline logs is determined. The attributes that form the data quality model are

- accuracy
- repeatability
- integrity
- traceability
- timeliness
- relevance
- completeness
- sufficiency
- interpretability
- reputation
- objectivity
- clarity
- availability
- accessibility
- security.

Accuracy

Accuracy is how close to the true value the data is within a specified degree of conformity (e.g., metrology and integrity). Accuracy is a function of the sensor design; the measurement cannot be made more accurate by varying operating techniques, but it can fail to conform to the defined accuracy as a result of several errors (e.g., incorrect calibration).

Repeatability

Repeatability of data is the consistency of two or more data products acquired or processed using the same system under the same conditions. Reproducibility, on the other hand, is the data consistency of two

or more data products acquired or processed using different systems or under different conditions. The majority of wireline measurements have a defined repeatability range, which is applicable only when the measurement is conducted under the same conditions. Repeatability is used to validate the measurement acquired during the main logging pass, as well as identify anomalies that may arise during the survey for relogging.

Integrity

The integrity of data is essential for the believability of data. Data with integrity is not altered or tampered with. There are situations in which data is altered in a perfectly acceptable manner (e.g., applying environmental corrections, using processing parameters for interpretation). Any such changes, which involve an element of judgment, are not done to intentionally produce results inconsistent with the measurements or processed data and are to the best and unbiased judgment of the interpreter. Results of interpretation activities are auditable, clearly marked, and traceable.

Traceability

Traceability of data refers to having a complete chain defining a measurement from its point of origin (sensor) to its final destination (formation property). At each step of the chain, appropriate measurement standards are respected, well documented, and auditable.

Timeliness

Timeliness is the availability of the data at the time required. Timeliness ensures that all tasks in the process of acquiring data are conducted within the time window defined for such tasks (e.g., wellsite calibrations and checks are done within the time window defined).

Relevance

Relevance is the applicability and helpfulness of the acquired dataset within the business context (e.g., selection of the right service for the well conditions). Most services have a defined operating envelope in which the measurement is considered valid. Measurements conducted outside their defined envelope, although the measurement process may have been completed satisfactorily, are almost always irrelevant (e.g., recording an SP curve in an oil-base mud environment).

Completeness

Completeness ensures that the data is of sufficient breadth, depth, and scope to meet predefined requirements. This primarily means that all required measurements are available over the required logging interval, with no missing curves or gaps in curves over predefined required intervals of the log.

Sufficiency

Sufficiency ensures that the amount of data that is acquired or processed meets the defined objectives of the operation. For example, when the defined objective is to compute the hole volume of an oval hole, a four-arm caliper service—at minimum—must be used. Using a single-arm caliper service would not provide sufficient information to achieve the defined objective and would inadvertently result in over-estimation of the hole volume.

Interpretability

Interpretability of data requires that the measurement is specified in appropriate terminology and units and that the data definitions are clear and documented. This is essential to ensure the capability of using the data over time (i.e., reusability).

Reputation

Reputation refers to data being trusted or highly regarded in terms of its source, content, and traceability.

Objectivity

The objectivity of data is an essential attribute of its quality, unbiased and impartial, both at acquisition and at reuse.

Clarity

Clarity refers to the availability of a clear, unique definition of the data by using a controlled data dictionary that is shared. For example, when “NPHI” is referred to, it must be understood by all that NPHI is the thermal neutron porosity in porosity units (m^3/m^3 or ft^3/ft^3), computed from a thermal neutron ratio that is calibrated using a single-point calibration mechanism (gain only), and is the ratio of counts from a near and a far receiver, with the counts corrected only for hole size and not corrected for detector dead time.

Clarity ensures objectivity and interpretability over time.

Availability

Availability of data ensures the distribution of data only to the intended parties at the requested time (i.e., no data is disclosed to any other party than the owner of the data without prior written permission).

Accessibility

Accessibility ensures the ease of retrievability of data using a classification model. Wireline data are classified into three datasets:

- Basic dataset is a limited dataset suitable for quicklook interpretation and transmission of data.
- Customer dataset consists of a complete set of data suitable for processing (measurements with their associated calibrations), recomputing (raw curves), and validating (log quality control [LQC] curves) the measurements of the final product delivered. The customer dataset includes all measurements required to fully reproduce the data product with a complete and auditable traceability chain.
- Producer dataset includes Schlumberger-proprietary data, which are meaningful only to the engineering group that supports the tool in question (e.g., the 15th status bit of ADC015 on board EDCIB023 in an assembly).

Security

The security of data is essential to maintain its confidentiality and ensure that data files are clean of malware or viruses.

Calibration theory

The calibration of sensors is an integral part of metrology, the science of measurement. For most measurements, one of the following types of calibrations is employed:

- single-point calibration
- two-point calibration
- multiple-point calibration.

Because most measurements operate in a region of linear response, any two points on the response line can be compared with their associated calibration references to determine a gain and an offset (two-point calibration) or a gain (single-point calibration). The gain and offset values are used in the calibration value equation, which converts any measured value to its associated calibrated value.

There are three events that measurements may have one or more of:

- Master calibration: Performed at the shop on a quarterly or monthly basis, a master calibration usually comprises a primary measurement done to a measurement standard and a reference measurement that serves as a baseline for future checks. The primary measurement is the calibration of the sensor used for converting a raw measurement into its final output.
- Wellsite before-survey calibration or check: Measurements that have a master calibration are normally not calibrated at the wellsite; rather, the reference measurement conducted in the master calibration is repeated at the wellsite before conducting the survey to ensure that the tool response has not changed. Measurements that do not have a master calibration may employ a wellsite calibration that is conducted prior to starting the survey.
- Wellsite after-survey check: Some measurements employ an after-survey check (optional for most measurements) to ensure that the tool response has not changed from before the survey.

All such events are recorded in a calibration summary listing (CSL) (Fig. 1).

The calibration summary listing contains an auditable trail of the event:

- equipment with serial numbers
- actual measurement and the associated range (minimum, nominal, and maximum)
- time the event was conducted.

For the event to be valid, the measurement must fall within the defined minimum and maximum limits, using the same equipment (verified through the mnemonics and serial numbers), and performed on time (verified through the time stamp on the summary listing).

More details on the calibrations associated with the wide range of Schlumberger wireline measurements are in the *Logging Calibration Guide*, which is available through your local Schlumberger representative.

Hostile Natural Gamma Ray Sonde / Equipment Identification	
Primary Equipment: HNGS Sonde	HNGS - BA
Auxiliary Equipment: HNGS Sonde Housing Gamma Source Radioactive	HNSH - BA GSR - U

Hostile Natural Gamma Ray Sonde Master Calibration											
Detector 1 Calibration											
Phase	Na 511 Peak Set Point		Value	Phase	Th Peak Loc		Value	Phase	Th Peak Res %		Value
Master			42.00	Master			211.9	Master			7.396
	38.00 (Minimum)	40.00 (Nominal)	42.00 (Maximum)		201.0 (Minimum)	209.6 (Nominal)	218.3 (Maximum)		5.000 (Minimum)	7.000 (Nominal)	9.000 (Maximum)
Phase	Background Count Rate CPS		Value	Phase	Gain Ratio		Value				
Master			96.67	Master			0.9936				
	20.00 (Minimum)	142.5 (Nominal)	265.0 (Maximum)		0.9400 (Minimum)	1.000 (Nominal)	1.060 (Maximum)				
Master:											

Hostile Natural Gamma Ray Sonde Master Calibration											
Detector 2 Calibration											
Phase	Na 511 Peak Set Point		Value	Phase	Th Peak Loc		Value	Phase	Th Peak Res %		Value
Master			41.00	Master			211.1	Master			6.985
	38.00 (Minimum)	40.00 (Nominal)	42.00 (Maximum)		201.0 (Minimum)	209.6 (Nominal)	218.3 (Maximum)		5.000 (Minimum)	7.000 (Nominal)	9.000 (Maximum)
Phase	Background Count Rate CPS		Value	Phase	Gain Ratio		Value				
Master			96.01	Master			1.017				
	20.00 (Minimum)	142.5 (Nominal)	265.0 (Maximum)		0.9400 (Minimum)	1.000 (Nominal)	1.060 (Maximum)				
Master:											

Figure 1. Example of a master calibration.

Depth Control and Measurement

Overview

Depth is the most fundamental wireline measurement made; therefore, it is the most important logging parameter. Because all wireline measurements are referenced to depth, it is absolutely critical that depth is measured in a systematic way, with an auditable record to ensure traceability.

Schlumberger provides through its wireline services an absolute depth measurement and techniques to apply environmental corrections to the measurement that meet industry requirements for subsurface marker referencing.

The conveyance of tools and equipment by means of a cable enables the determination of an absolute wellbore depth under reasonable hole conditions through the strict application of wellsite procedures and the implementation of systematic maintenance and calibration programs for measurement devices. The essentials of the wireline depth measurement are the following:

- Depth is measured from a fixed datum, termed the depth reference point, which is specified by the client.
- The Integrated Depth Wheel (IDW) device (Fig. 1) provides the primary depth measurement, with the down log taken as the correct depth reference.
- Slippage in the IDW wheels is detected and automatically compensated for by the surface acquisition system.
- The change in elastic stretch of the cable resulting from changing direction at the bottom log interval is measured and applied to the log depth as a delta-stretch correction.
- Other physical effects on the cable in the borehole, including changes in length owing to wellbore profile, temperature, and other hole conditions, are not measured but can be corrected for after logging is complete.
- Subsequent logs that do not require a primary depth measurement are correlated to a reference log specified by the client, provided that enough information exists to validate the correctness of the depth measured on previous logs.
- Traceability of the corrections applied should be such that recovery of absolute depth measurements is possible after logging, if required.

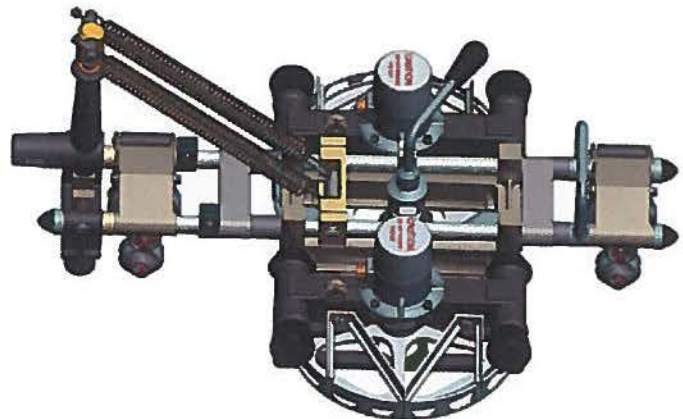

Figure 1. Integrated Depth Wheel device.

By strict application of this procedure, Schlumberger endeavors to deliver depth measurement with an accuracy of ± 5 ft per 10,000 ft and repeatability of ± 2 ft per 10,000 ft [± 1.5 m and ± 0.6 m per 3,050 m, respectively] in vertical wells.

Specifications

Measurement Specifications	
Accuracy	± 5 ft per 10,000 ft [± 1.5 m per 3,050 m]
Repeatability	± 2 ft per 10,000 ft [± 0.6 m per 3,050 m]

Calibration

The IDW calibration must be performed every 6 months, after 50 well-site trips, or after 500,000 ft [152,400 m] have passed over the wheel, whichever comes first. The IDW device is calibrated with a setup that is factory-calibrated with a laser system, which provides traceability to international length standards.

Tension devices are calibrated every 6 months for each specific cable by using a load cell.

For more information, refer to the *Logging Calibration Guide*, which is available through your local Schlumberger representative.

The high-precision IDW device uses two wheels that measure cable motion at the wireline unit. Each wheel is equipped with an encoder, which generates an event for every 0.1 in [0.25 cm] of cable travel. A wheel correction is applied to obtain the ideal of one pulse per 0.1 in of cable travel.

Integration of the pulses results in the overall measured depth, which is the distance measured along the actual course of the borehole from the surface reference point to a point below the surface.

A tension device, commonly mounted on the cable near the IDW device, measures the line tension of the cable at the surface.

Depth control procedure

On arrival at the wellsite, the wireline crew obtains all available information concerning the well and the depth references (wellsite data) from the client's representative. Information related to the calibrations of the IDW device and the tension device is entered in the surface acquisition system.

First trip

First log

The procedure for the first log in a well consists of the following major steps:

1. Set up the depth system, and ensure that wheel corrections are properly set for each encoder.
2. Set tool zero (Fig. 2) with respect to the client's depth reference.
3. Measure the rig-up length (Fig. 3) between the IDW device and the rotary table at the surface. Investigate, and correct as necessary, any significant change in the rig-up length from that measured with the tool close to the surface.
4. Run in the hole with the toolstring.
5. Measure the rig-up length (Fig. 3) between the IDW device and the rotary table at bottom.
6. Correct for the change in elastic stretch resulting from the change in cable or tool friction when logging up.
7. Record the main log.
8. Record one or more repeat sections for repeatability analysis.[†]
9. Pull the toolstring out of the hole and check the depth on return to surface.

To set tool zero on a land rig, fixed platform, or jackup, the toolstring is lowered a few feet into the hole and then pulled up, stopping when the tool reference is at the client's depth reference point (Fig. 2).



Figure 2. Tool zero.

[†]Operational considerations may dictate a change in the order of Steps 6–8.

The following procedure for setting tool zero is used on floating vessels, semisubmersible rigs, and drillships equipped with a wave motion compensator (WMC):

1. With the WMC deactivated, stop the tool reference at the rotary table, and set the system depth to zero.
2. Lower the tool until the logging head is well below the riser slip joint, then flag the cable at the rotary table and record the current depth.
3. Have the driller pull up slowly on the elevators, until the WMC is stroking about its midpoint.
4. Raise or lower the tool until the cable flag is back at the rotary table.
5. Set the system depth to the depth recorded in Step 2.

Measuring the cable rig-up length ensures that the setup has not changed while running in the well (e.g., slack in the logging cable, movement of the logging unit, the blocks, or the sheaves). The following procedure is used to measure the rig-up length of the cable (Fig. 3):

1. Run in the hole about 100 ft [30 m], flag the cable at the IDW device, and note the depth.
2. Lower the toolstring until the flag is at the rotary table. Subtract the depth recorded in Step 1 from the current depth. The result is the rig-up length at surface (RULS).
3. Record RULS.

The speed used to proceed in the hole should avoid tool float (caused by excessive force owing to mud viscosity acting on the tool) or birdcaging of the cable. To the extent possible and operational considerations permitting, a constant speed should be maintained while running downhole. At the bottom of the hole, the measurement process is conducted to obtain the rig-up length at bottom (RULB), which is also recorded. If RULB differs from RULS by more than 1 ft [0.3 m], the rig-up has changed and the cause of the discrepancy must be investigated and eliminated or corrected for.

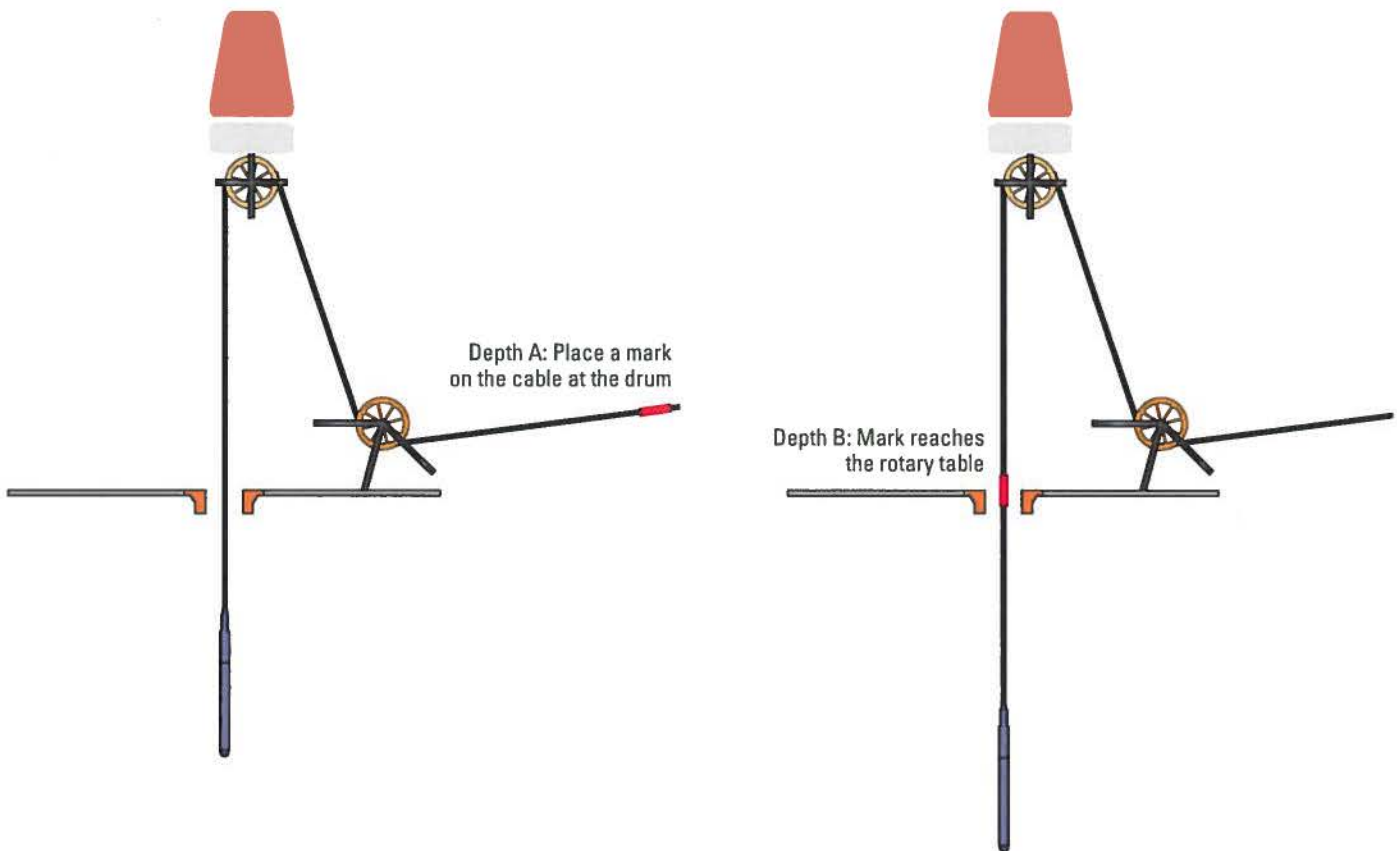

Figure 3. Rig-up length measurement procedure.

The rig-up length correction ($RULC = RULS - RULB$) is applied by adding RULC to the system depth. RULC is recorded in the Depth Summary Listing (Fig. 5).

To correct for the change of elastic stretch, the log-down/log-up method (Fig. 4) is applied as close as is reasonable to the bottom log interval:

1. Continue toward the bottom of the well at normal speed.
2. Log down a short section (minimum 200 ft [60 m]) close to the bottom, making sure to include distinctive formation characteristics for correlation purposes.
3. At the bottom, open calipers (if applicable) and log up a section overlapping the down log obtained in Step 2.
4. Using the down log as a reference, adjust the up-log depth to match the down log.

5. The adjustment is the stretch correction (SCORR) resulting from the change in tension. SCORR should be added to the hardware depth before logging the main pass.

6. Record SCORR and the depth at which it was determined in the Depth Summary Listing (Fig. 5).

If it is determined to be too risky to apply the delta-stretch correction before starting the log, the log can be recorded with no correction and then depth-shifted after the event with a playback. This procedure must be documented clearly in the Depth Summary Listing remarks. Such a procedure is justified when the well is excessively hot or sticky, and following the steps previously outlined could lead to a significant risk of tool problems or failure to return to bottom (and thus to loss of data).

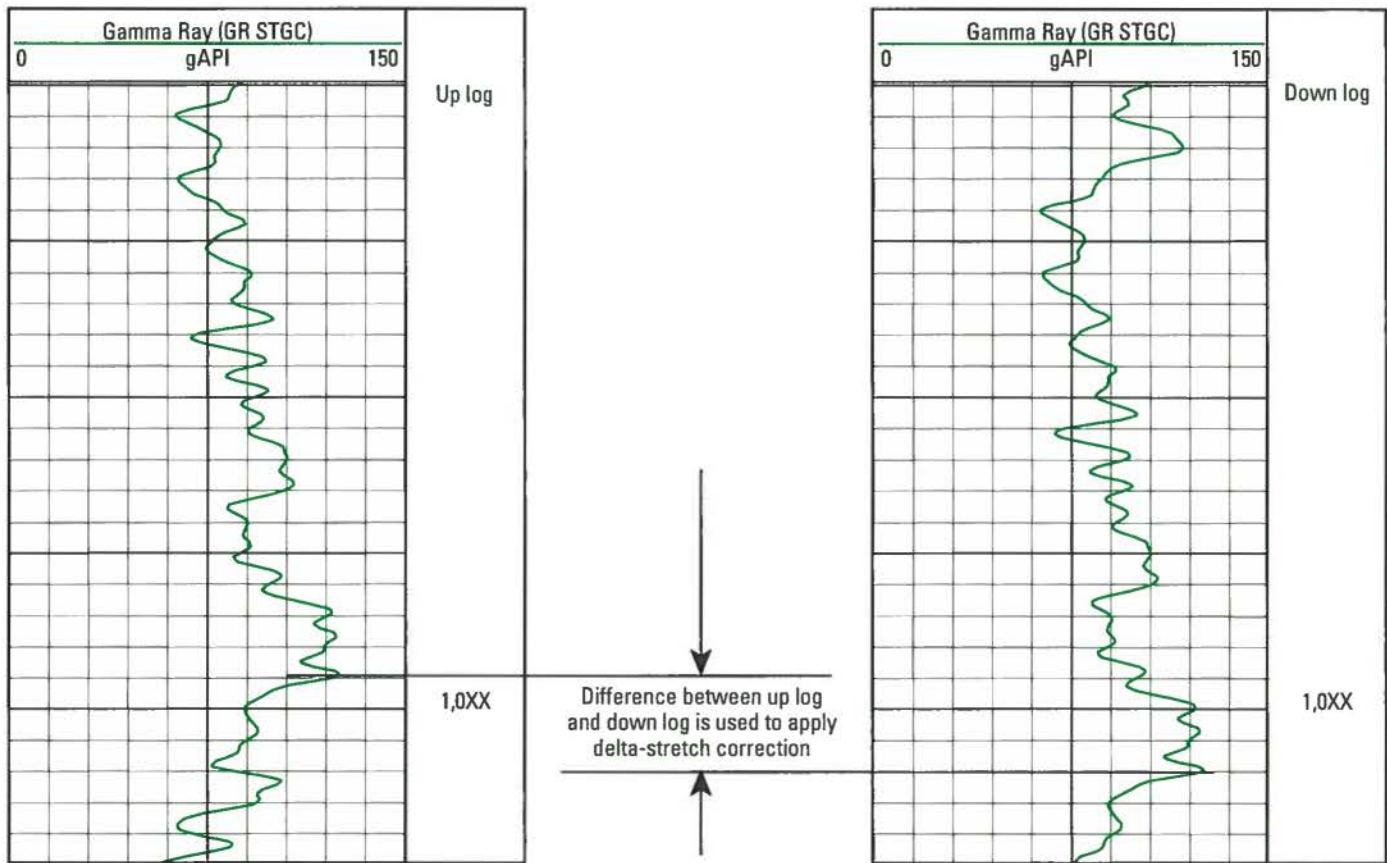

Figure 4. Stretch correction.

After pulling out of the hole, tool zero is checked at the surface, as was done before running in the hole, and the difference is recorded in the Depth Summary Listing (Fig. 5). In deviated wells in particular, environmental effects may lead to a re-zero error, with the depth system reading other than zero when the tool reference is positioned opposite the log reference point after return to the surface. Recording this difference is an essential step in controlling the quality of any depth

correction computed after the log, because that depth correction process should include an estimate of the expected re-zero error.

All information related to the procedure followed for depth control should be recorded in the Depth Summary Listing (Fig. 5) for future reference.

DEPTH SUMMARY LISTING		
Date Created: 10-Dec-20XX 12:09:15		
Depth System Equipment		
Depth Measuring Device	Tension Device	Logging Cable
Type : IDW-B Serial Number: 4XX Calibration Date: 10-Dec-20XX Calibrator Serial Number: 15XX Calibration Cable Type: 7-46P Wheel Correction 1: -3 Wheel Correction 2: -2	Type : CMTD-B/A Serial Number: 82XXX Calibration Date: 10-Dec-20XX Calibrator Serial Number: 98XX Number of Calibration Points: 10 Calibration RMS: 11 Calibration Peak Error: 15	Type : 7-46P Serial Number: 83XX Length: 18750 FT Conveyance Method: Wireline Rig Type: LAND
Depth Control Parameters		
Log Sequence:	First Log in the Well	
Rig Up Length At Surface:	352.00 FT	
Rig Up Length At Bottom:	351.00 FT	
Rig Up Length Correction:	1.00 FT	
Stretch Correction:	5.00 FT	
Tool Zero Check At Surface:	0.50 FT	
Depth Control Remarks		
<ol style="list-style-type: none"> Subsequent trip to the well. Downlog correlated to reference log XXX by YYY company dated DD-MM-YYYY. Non-Schlumberger reference log. Full 1st trip to the well depth control procedure applied, which required the addition of XX ft to the down log. Delta-stretch correction was conducted at 12XXX ft and applied to depth prior to recording the main log. Z-chart used as a secondary depth check. 		

Figure 5. Depth Summary Listing for the first trip, first log in the well.

Subsequent logs

The depth of subsequent logs on the same trip is tied into the first log using the following procedure:

1. Properly zero the tool as for the first log.
2. The rig-up length does not need to be measured if the setup has not changed since the previous log.
3. Match depths with the first log by using a short up-log pass.
4. Run the main log and repeat passes as necessary.
5. Record the re-zero error in the Depth Summary Listing. This is part of the traceability that makes possible the determination of absolute depth after the event, if required.

Subsequent logs should be on depth with the first log over the complete interval logged. However, particularly when toolstrings of different

weights are run in deviated wells, the relative depths of the logs can change over long logging intervals. Subsequent correction should enable removing all discrepancies.

The amount and sign of the correction applied and the depth at which it was determined must be recorded in the Depth Summary Listing. For any down log made, the delta-stretch correction should also be recorded, as well as the depth at which it was determined.

All information related to the procedure followed for depth control of subsequent logs of the first trip should be recorded in the Depth Summary Listing (Fig. 6).

DEPTH SUMMARY LISTING		
Date Created: 10-Dec-20XX 14:38:50		
Depth System Equipment		
Depth Measuring Device	Tension Device	Logging Cable
Type : IDW-B Serial Number: 4XX Calibration Date: 10-Dec-20XX Calibrator Serial Number: 15XX Calibration Cable Type: 7-46P Wheel Correction 1: -3 Wheel Correction 2: -2	Type : CMTD-B/A Serial Number: 82XXX Calibration Date: 10-Dec-20XX Calibrator Serial Number: 98XX Number of Calibration Points: 10 Calibration RMS: 11 Calibration Peak Error: 15	Type : 7-46P Serial Number: 83XX Length: 18750 FT Conveyance Method: Wireline Rig Type: LAND
Depth Control Parameters		
Log Sequence:	Subsequent trip In the Well	
Reference Log Name:	AIT-GR	
Reference Log Run Number:	1	
Reference Log Date:	10-Dec-20XX	
Depth Control Remarks		
<ol style="list-style-type: none"> 1. Subsequent log on 1st trip correlated to first log in the well from XX000 to XX200 ft 2. Speed correction not applied. 3. Z-chart used as a secondary depth check. 4. Correction applied to match reference log = XX ft, determined at depth XXX00 ft. 5. No rigup changes from previous log. 		

Figure 6. Depth Summary Listing for first trip, subsequent logs.

Subsequent trips

If there is not enough information in the Depth Summary Log from previous trips to ensure that correct depth control procedures have been applied, subsequent trips are treated as a first trip, first log in the well.

If sufficient information from previous trips was recorded to show that correct depth control procedures were applied, the previous logs can be used as a reference. The subsequent trips proceed as if running the initial trip with the following exceptions:

1. In conjunction with the client, decide which previous log to use as the downhole depth reference. Ensure that a valid copy of the reference log is available for correlation purposes. If the depth reference is a wireline log from a oilfield service provider other than Schlumberger, proceed as for the first log in the well, and investigate and document any discrepancies found with respect to the reference log.
2. Run in the hole and record a down log across an overlap section at the bottom of the reference log. If the overlap section is off by less than 5 ft per 10,000 ft, adjust the depth to match the current down

log with the reference log. This adjustment ensures that the down section of the current log is using the same depth reference as the correlation log. Record any corrections made as the subsequent trip down log correction.

3. If the overlap log is off by more than 5 ft per 10,000 ft, investigate and resolve any problems. Record any depth discrepancies. Consult with the client to decide which log to use as the depth reference.
4. Run down to the bottom of the well at a reasonable speed so that the tool does not float.
5. Log main and repeat passes, correcting for stretch following the first trip procedure.
6. The logging pass should overlap with the reference log by at least 200 ft, if possible. The depth should match the reference log. Any discrepancies should be noted in the Depth Summary Listing or the log remarks.

All information related to the depth control procedure followed should be recorded in the Depth Summary Listing (Fig. 7).

DEPTH SUMMARY LISTING		
Date Created: 10-Dec-20XX 14:26:56		
Depth System Equipment		
Depth Measuring Device	Tension Device	Logging Cable
Type : IDW-B Serial Number: 4XX Calibration Date: 10-Dec-20XX Calibrator Serial Number: 15XX Calibration Cable Type: 7-46P Wheel Correction 1: -3 Wheel Correction 2: -2	Type : CMTD-B/A Serial Number: 82XXX Calibration Date: 10-Dec-20XX Calibrator Serial Number: 9851 Number of Calibration Points: 10 Calibration RMS: 11 Calibration Peak Error: 15	Type : 7-46P Serial Number: 83XX Length: 18750 FT Conveyance Method: Wireline Rig Type: LAND
Depth Control Parameters		
Log Sequence:	Subsequent trip to the well	
Reference Log Name:	AIT-GR	
Reference Log Run Number:	1	
Reference Log Date:	10-Dec-20XX	
Subsequent Trip Down Log Correction:	1.00 FT	
Depth Control Remarks		
1. Subsequent trip to the well. 2. Down pass correlated to reference log within +/- 0.05%. 3. Correlation to reference log performed from XX000 to XX200 ft. 4. Correction applied to match reference log = XX ft, determined at depth XXX00 ft.. 5. Z-chart used as a secondary depth check.		

Figure 7. Depth Summary Listing for subsequent trips.

Spudding

Spudding is not a recommended procedure, but it is sometimes necessary to get past an obstruction in the borehole. It generally involves making multiple attempts from varying depths or using varying cable speed to get past an obstruction.

If the distance pulled up is small, the error introduced is also small. In many cases, however, the tool is pulled back up for a considerable distance (i.e., increasing cable over wheel) in an attempt to change its orientation. Then, the correction necessary to maintain proper depth control becomes sizeable.

If multiple attempts are made, the correction necessary to maintain proper depth control also becomes sizeable.

When possible, log data is recorded over the interval where spudding occurs in case consequent damage occurs to the equipment that prevents further data acquisition. If it is not possible to pass an obstruction in the well, data is recorded while pulling out of the hole for remedial action.

Absolute depth

Measurements made with wireline logs are often used as the reference for well depth. However, differences are usually noted between wireline depth and the driller's depth. Which one is correct? The answer is neither. For more information, refer to SPE 110318, "A Technique for Improving the Accuracy of Wireline Depth Measurements."

Wireline depth measurement is subject to environmental corrections that vary with many factors:

- well profile
- mud properties
- toolstring weight
- cable type
- temperature profile
- wellbore pressure
- logging speed.

All these effects may differ from one well to another, so the depth corrections required also differ. Because of the number of factors involved, the corrections can be applied through a numerical model.

Logging down

Any short element of cable that is spooled off the winch drum as a tool is lowered downhole takes up a tension sufficient to support the weight of the tool in the well plus the weight of the cable between the winch and the tool, minus any frictional force that helps support the tool and

cable. This prestretched cable passes the IDW device and its length is thus measured in the stretched condition. When this element of cable is downhole, the tension at the surface can be quite different. However, the tension on this element remains the same because it is still supporting the weight of the tool plus the weight of the cable between itself and the tool minus the frictional force.

If it is assumed that the frictional force is constant and that temperature and pressure do not affect the cable length, the tension on the cable—and thus the cable length—stays constant as the tool is lowered in the hole. Considering that all such elements remain at constant length once they have been measured, it follows that the down log is on depth. This means that the encoder-measured depth incorporates the stretched cable length, and no additional stretch correction is required.

Logging up

When the tool reaches the bottom of the well, the winch direction is reversed. This has the effect of inverting the sign of the frictional component acting on the tool and cable. In addition, if a caliper is opened, the magnitude of the frictional force can change. As a result, the cable everywhere in the borehole is subject to an increase in tension, and thus an increase in stretch.

For the surface equipment to track the true depth correctly, a delta-stretch correction must be added to compensate for the friction change (Fig. 4). Once the correction has been applied, the argument used while running in hole is again applicable, and the IDW correctly measures the displacement of the tool provided there are no further changes in friction.[‡]

Deviated wells

In deviated wells, the preceding depth analysis applies only to the vertical section of the well. Once the tool reaches the dogleg, lateral force from the wellbore supports part of the tool weight. The tool is thus shallower than the measured depth on surface; i.e., the recorded data appear deeper than the actual tool position. This is commonly referred to as tool float.

Correction modeling

Correction modeling software estimates the delta-stretch correction to be applied at the bottom of the well, as well as the expected tool re-zero depth upon return to the surface. This software can be used to correct the depth after logging. Contact your local Schlumberger representative for more information.

[‡]The main assumptions remain that the friction is constant (other than the change due to reversal of direction of cable motion), and that temperature and pressure effects on the cable may be ignored.

Platform Express

Overview

Platform Express* integrated wireline logging technology employs either the AIT* array induction imager tool or High-Resolution Azimuthal Laterolog Sonde (HALS) as the resistivity tool. The Three-Detector Lithology Density (TLD) tool and Micro-Cylindrically Focused Log (MCFL) are housed in the High-Resolution Mechanical Sonde (HRMS) powered caliper. Above the HRMS are a compensated thermal neutron and gamma ray in the Highly Integrated Gamma Ray Neutron Sonde

(HGNS) and a single-axis accelerometer. The real-time speed correction provided by the single-axis accelerometer for sensor measurements enables accurate depth matching of all sensors even if the tool cannot move smoothly while recording data. The resistivity, density, and micro-resistivity measurements are high resolution. Logging speed is twice the speed at which a standard triple-combo is run.

Specifications

Measurement Specifications

Output	HGNS: Gamma ray, neutron porosity, tool acceleration HRMS: Bulk density, photoelectric factor (PEF), borehole caliper, microresistivity HALS: Laterolog resistivity, spontaneous potential (SP), mud resistivity (R_m) AIT: Induction resistivity, SP, R_m
Logging speed	3,600 ft/h [1,097 m/h]
Mud weight or type limitations	None
Combinability	Bottom-only toolstring with HALS or AIT tool Combinable with most tools
Special applications	Good-quality data in sticky or rugose holes Measurement close to the bottom of the well

Platform Express Component Specifications				
	HGNS	HRMS	HALS	AIT-H and AIT-M
Range of measurement	Gamma ray: 0 to 1,000 gAPI Neutron porosity: 0 to 60 V/V	Bulk density: 1.4 to 3.3 g/cm ³ PEF: 1.1 to 10 Caliper: 22 in [55.88 cm]	0.2 to 40,000 ohm.m	0.1 to 2,000 ohm.m
Vertical resolution	Gamma ray: 12 in [30.48 cm] Porosity: 12 in [30.48 cm]	Bulk density: 18 in [45.72 cm] in 6-in [15.24-cm] borehole	Standard resolution: 18 in [45.72 cm] High resolution: 8 in [20.32 cm] in 6-in [15.24-cm] borehole	1, 2, and 4 ft [0.30, 0.61, and 1.22 m]
Accuracy	Gamma ray: ±5% Porosity: 0 to 20 V/V = ±1 V/V, 30 V/V = ±2 V/V, 45 V/V = ±6 V/V	Bulk density: ±0.01 g/cm ³ (accuracy ¹), 0.025 g/cm ³ (repeatability) Caliper: 0.1 in [0.25 cm] (accuracy), 0.05 in [0.127 cm] (repeatability) PEF: 0.15 (accuracy ²)	1 to 2,000 ohm.m: ±5%	Resistivities: ±0.75 ms/m (conductivity) or 2% (whichever is greater)
Depth of investigation	Gamma ray: 24 in [61.0 cm] Porosity: -9 in [-23 cm] (varies with hydrogen index of formation)	Density: 5 in [12.70 cm]	32 in [81 cm] (varies with formation and mud resistivities)	AO/AT/AF10 ³ : 10 in [25.40 cm] AO/AT/AF20: 20 in [50.80 cm] AO/AT/AF30: 30 in [76.20 cm] AO/AT/AF60: 60 in [152.40 cm] AO/AT/AF90: 90 in [228.60 cm]
Outside diameter	3.375 in [8.57 cm]	4.77 in [12.11 cm]	3.625 in [9.21 cm]	3.875 in [9.84 cm]
Length	10.85 ft [3.31 m]	12.3 ft [3.75 m]	16 ft [4.88 m]	16 ft [4.88 m]
Weight	171.7 lbm [78 kg]	313 lbm [142 kg]	221 lbm [100 kg]	AIT-H: 255 lbm [116 kg] AIT-M: 282 lbm [128 kg]

¹ Bulk density accuracy defined only for the range of 1.65 to 3.051 g/cm³

² PEF accuracy defined for the range of 1.5 to 5.7

³ AO = 1-ft [0.30-m] vertical resolution, AT = 2-ft [0.61-m] vertical resolution, AF= 4-ft [1.22-m] vertical resolution

Calibration

Master calibration of the HGNS compensated neutron tool must be performed every 3 months. Master calibration of the HRDD density tool must be performed monthly.

For calibration of the gamma ray tool of the HGNS, the area must be free from outside nuclear interference. Gamma ray background and plus calibrations are typically performed at the wellsite with the radioactive sources removed so that no contribution is made to the signal. Calibration of the tool in a vertical position is recommended. The background measurement is made first, and then a plus measurement is made by wrapping the calibration jig around the tool housing and positioning the jig on the knurled section of the gamma ray tool.

Calibration of the HGNS compensated neutron tool uses an aluminum insert sleeve seated in a tank filled with fresh water. The bottom edge of the tank is at least 33 in [84 cm] above the floor, and an 8-ft [2.4-m] perimeter around the tank is clear of walls or stationary items and all equipment, tools, and personnel. The tool is vertically lowered into the tank and sleeve so that only the taper of a centering clamp placed on the tool housing at the centering mark enters the water and the clamp supports the weight of the tool.

Calibration of the HRDD density tool uses an aluminum block and a magnesium block with multiple inserts.

Tool quality control

Standard curves

The Platform Express standard curves are listed in Table 1.

Table 1. Platform Express Standard Curves

Output Mnemonic	Output Name	Output Mnemonic	Output Name
AHF10, AHF20, AHF30, AHF60, AHF90	Array induction resistivity with 4-ft [1.2-m] vertical resolution and median depth of investigation of 10, 20, 30, 60, or 90 in [25.4, 50.8, 76.2, 152.4, or 228.6 cm]	HTNP	High-resolution thermal neutron porosity
AHO10, AHO20, AHO30, AHO60, AHO90	Array induction resistivity with 1-ft [0.3-m] vertical resolution and median depth of investigation of 10, 20, 30, 60, or 90 in	MVRA	Monitoring to resistivity of the invaded zone (R_{xo}) voltage ratio
AHT10, AHT20, AHT30, AHT60, AHT90	Array induction resistivity with 2-ft [0.6-m] vertical resolution and median depth of investigation of 10, 20, 30, 60, or 90 in	NPHI	Thermal neutron porosity borehole-size corrected
ATEMP	HGNS accelerometer temperature	NPOR	Enhanced-resolution processed thermal porosity
CFGR	Gamma ray borehole-correction factor	PEF8	Formation photoelectric factor at standard 8-in [20.3-cm] resolution
CFTC	Corrected far thermal count	PEFI	Formation photoelectric factor at standard 2-in [5.1-cm] resolution
CNTC	Corrected near thermal count	PEFZ	Formation photoelectric factor at standard 18-in [45.7-cm] resolution
CTRM	MCFL hardware contrast indicator	RHO8	Formation density at standard 8-in resolution
DNPH	Delta neutron porosity	RHOI	Formation density at standard 2-in resolution
ECGR	Environmentally corrected gamma ray	RHOZ	Formation density at standard 18-in resolution
EHGR	High-resolution environmentally corrected gamma ray	RSO8	High-resolution resistivity standoff
EHMR	Confidence on resistivity standoff	RVV	MCFL vertical voltage
ERBR[n]	Resistivity reconstruction error	RXGR	Global current-based resistivity
ERMC	Confidence on standoff zone resistivity	RXIB	Bucking (A1) current
ERXO	Confidence on invaded zone resistivity	RXIG	Global (A0) current
ExSZ[n]	xS reconstruction error	RXIGIO	Global to B0 current ratio
GDEV	HGNS deviation	RXO8	Micro-cylindrically focused R_{xo} measurement at 8-in resolution
GR	Gamma ray	RXOI	Micro-cylindrically focused R_{xo} measurement at 2-in resolution
GREZ	High-Resolution Density Detector (HRDD) cost function	RXOZ	Micro-cylindrically focused R_{xo} measurement at standard 18-in resolution
GTHV	HGNS gamma ray test high voltage	RXV	R_{xo} (A0) voltage
HAZ01	HGNS high-resolution acceleration	RXVB	Bucking (A1) voltage
HCAL	Caliper to measure borehole diameter	TNPH	Thermal neutron porosity environmentally corrected
HDRA	HRDD density correction	TREF	HGNS ADC reference
HDRX	B0 correction factor	U8	Formation volumetric photoelectric factor at standard 8-in resolution
HGR	High-resolution gamma ray	UI	Formation volumetric photoelectric factor at standard 2-in resolution
HLLD	HALS laterolog deep low-resolution measurement	UZ	Formation volumetric photoelectric factor at standard 18-in resolution
HLLS	HALS laterolog shallow low-resolution measurement	xCQR	xS crystal resolution
HMIN	Micro-inverse resistivity	xDTH	HRDD detector dither frequency
HMINO	Micro-normal resistivity	xLEW	xS low-energy window count rate
HNPO	High-resolution enhanced thermal neutron porosity	xOFC	HRDD detector offset control value
HRLD	HALS laterolog deep high-resolution measurement	xPHV	xS photomultiplier high voltage (command)
HRLS	HALS laterolog shallow high-resolution measurement	xSFF	xS form factor
HTEM	Cartridge temperature	xWTO	xS uncalibrated total count rate

Operation

The HGNS section of the Platform Express toolstring must be eccentric with a bow spring. The HRMS is positively eccentric with its own caliper, giving a borehole reaction force centered on the skid face.

The resistivity tool at the bottom of the Platform Express toolstring must be run with standoffs positioned at the top and bottom of the tool. It is important that the standoff size is the same at the top and bottom so that the sonde is not tilted with respect to the borehole.

Planning for selection of the induction or laterolog tool is important. See the "Resistivity Logging" section of this *Log Quality Control Reference Manual* for more details.

Formats

There are several quality control formats for Platform Express logs.

The HGNS format is shown in Fig. 1.

- Flag track
 - This track should show a deep green coherent pattern.
- Track 1
 - CFGR is the coefficient applied to the calibrated gamma ray to take into account the borehole corrections. Normally it is between 0.5 and 1.5.
 - GDEV output from the calibrated accelerometer should be between -10° and 90° , depending on the well.
 - DNPH is the difference between the environmentally corrected porosity and the uncorrected porosity. Usually the difference is within -10 to 10 V/V.

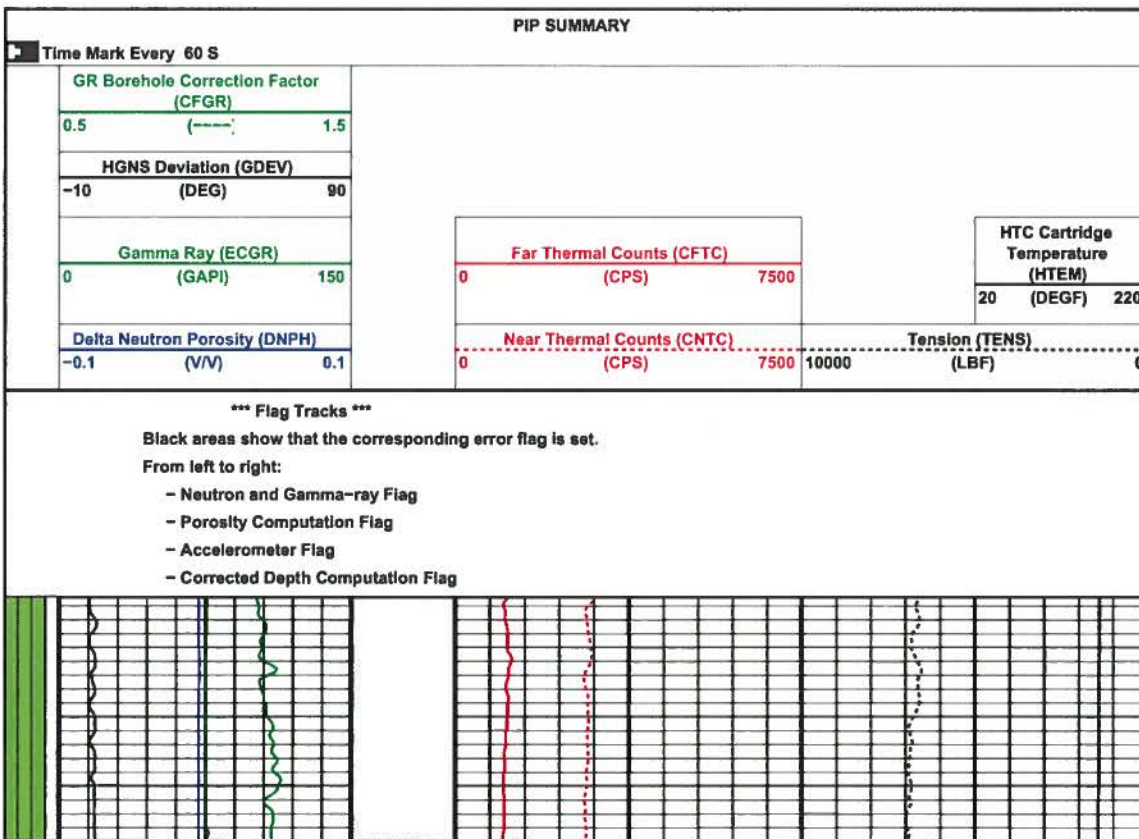

Figure 1. HGNS standard format for hardware.

The HRDD hardware format is in Fig. 2.

- Flag tracks
 - Three flag tracks aid in checking the backscatter (BS), short-spacing (SS), and long-spacing (LS) detector measurements. All bits in the tracks must show a deep green coherent color. Any other color may indicate a hardware failure.
- Tracks 1, 3, and 4
 - The $xWTO$ total count rate varies according to the density. In general, for BS, 300,000 counts/s < BWTO < 1,000,000 counts/s; for SS, 10,000 counts/s < SWTO < 500,000 counts/s; and for LS, 1,000 counts/s < LWTO < 50,000 counts/s (cps on the logs). A large count rate change may indicate a problem with the detector.
 - The value of $xSFF$ varies about zero (typically $\pm 0.125\%$). If the form factor is higher than the permissible value, there may be a problem with the detector.
 - Variation of $xCQR$ detector resolution is according to temperature and the presence of the logging source. Table 2 lists limits for the crystal resolution.

- Valid count rates for $xLEW$ are 0 to 10,000 counts/s for BS, 0 to 5,000 counts/s for SS, and 0 to 1,000 counts/s for LS. Any value outside its range may indicate a problem with the respective detector.
- The $xOFC$ unitless integer controls the average offset value and should range from 5 to 20.
- HRDD backscatter dither frequency ($xDTH$) can range from 1 to 900 Hz.
- The $xPHV$ photomultiplier tube high voltage should be near the value given during master calibration, but it changes with temperature.

Table 2. HRDD Limits for $xCQR$ Crystal Resolution

Detector	Stabilization Source Alone		With Logging Source	
	77 degF [25 degC]	257 degF [125 degC]	77 degF [25 degC]	257 degF [125 degC]
BS (BCQR)	13%	16%	12%	15%
SS (SCQR)	10%	10%	10%	10%
LS (LCQR)	9%–10%	11%	9%	11%

BS PM High Voltage (Command) (BPHV) 1600 (V) 1700		SS Low Energy Window CR (SLEW) 0 (CPS) 5000	LS Low Energy Window CR (LLEW) 0 (CPS) 1000
HRDD Backscatter Dither Frequency (BDTH) 0 (HZ) 250		SS Uncal. Total CR (SWTO) 0 (CPS) 500000	LS Uncal. Total CR (LWTO) 0 (CPS) 50000
HRDD BackScatter Offset Control Value (BOFC) 0 (←) 20		SS Crystal Resolution (SCQR) 5 (%) 25	LS Crystal Resolution (LCQR) 5 (%) 25
BS Low Energy Window CR (BLEW) 0 (CPS) 10000		SS Form Factor (SSFF) -0.5 (%) 0.5	LS Form Factor (LSFF) -0.5 (%) 0.5
BS Crystal Resolution (BCQR) 5 (%) 25		SS PM High Voltage (Command) (SPHV) 1600 (V) 1700	LS PM High Voltage (Command) (LPHV) 1600 (V) 1700
BS Form Factor (BSFF) -0.5 (%) 0.5		HRDD Short Spacing Dither Frequency (SDTH) 0 (HZ) 250	HRDD Long Spacing Dither Frequency (LDTH) 0 (HZ) 250
BS Uncal. Total CR (BWTO) 0 (CPS) 1000000	HILT Caliper (HCAL) 6 (IN) 16	HRDD Short Spacing Offset Control Value (SOFC) 0 (←) 20	HRDD Long Spacing Offset Control Value (LOFC) 0 (←) 20

*** Flag Tracks ***

Black areas show that the corresponding error flag is set.

For each xS detector subtrack, and from left to right :

- xS Offset Error or Low Energy Window Error
- xS Tau Loop Error (Pulse Shape Compensation Error)
- xS Stabilization Loop or Crystal Resolution Error

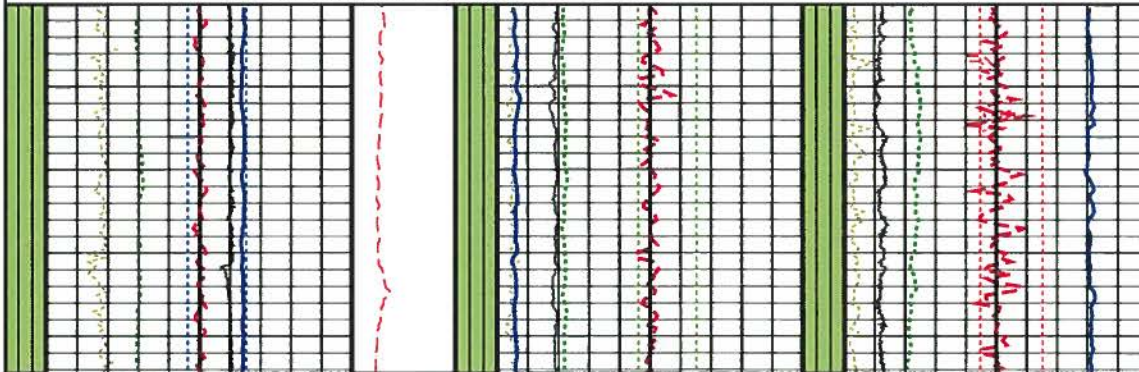

Figure 2. HRDD standard format for hardware.

The HRDD processing format is in Fig. 3.

- Tracks 1, 2, and 3
 - $E_{xSZ}[n]$ for each detector shows how close the reconstructed count rates are to the calibrated measured count rates. Ideally, they should vary about zero. A large bias observed on these errors for one or more energy windows is generally due to a problem in the calibration, excessive pad wear, or incorrect inversion algorithm selection.
 - GREZ indicates the confidence level in the estimations done in the model. The valid range is $0 < GREZ < 25$.

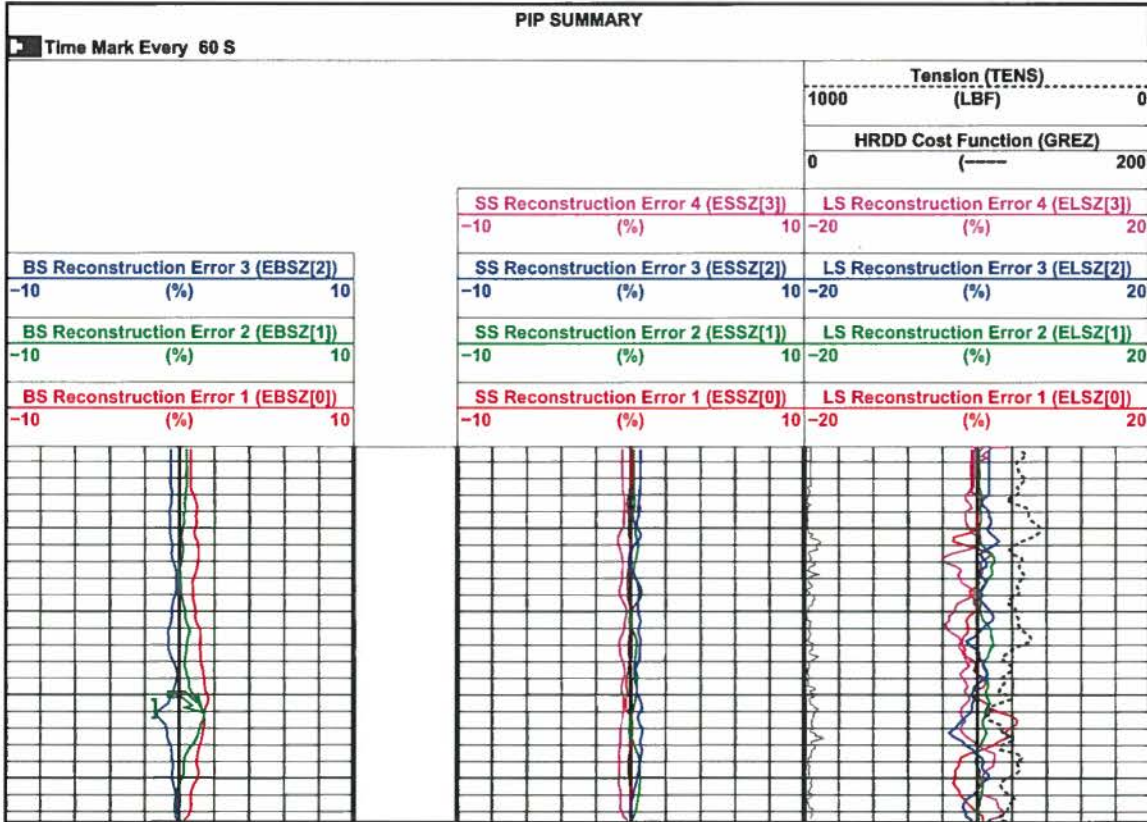

Figure 3. HRDD standard format for processing.

The MCFL hardware format is in Fig. 4.

- Flag track
 - The flag track should show a deep green coherent color. If a flag appears, it indicates a hardware malfunction.
- Track 1
 - RXIB and RXIG from A0 and A1 (the guard electrodes on the tool) should range from 2 to 2,000 mA. The ratio between both curves should be constant, with the value depending on the hole size.
 - RXV between the A0 electrode and the sonde body is typically about 50 to 200 mV for $R_{xo} > 10$ ohm.m. It is smaller when $R_{xo} < 10$ ohm.m, but it should not go below 5 mV.
 - RVV between A0 and the reference electrode N should read about one-half the value of RXV (R_{xo} voltage).

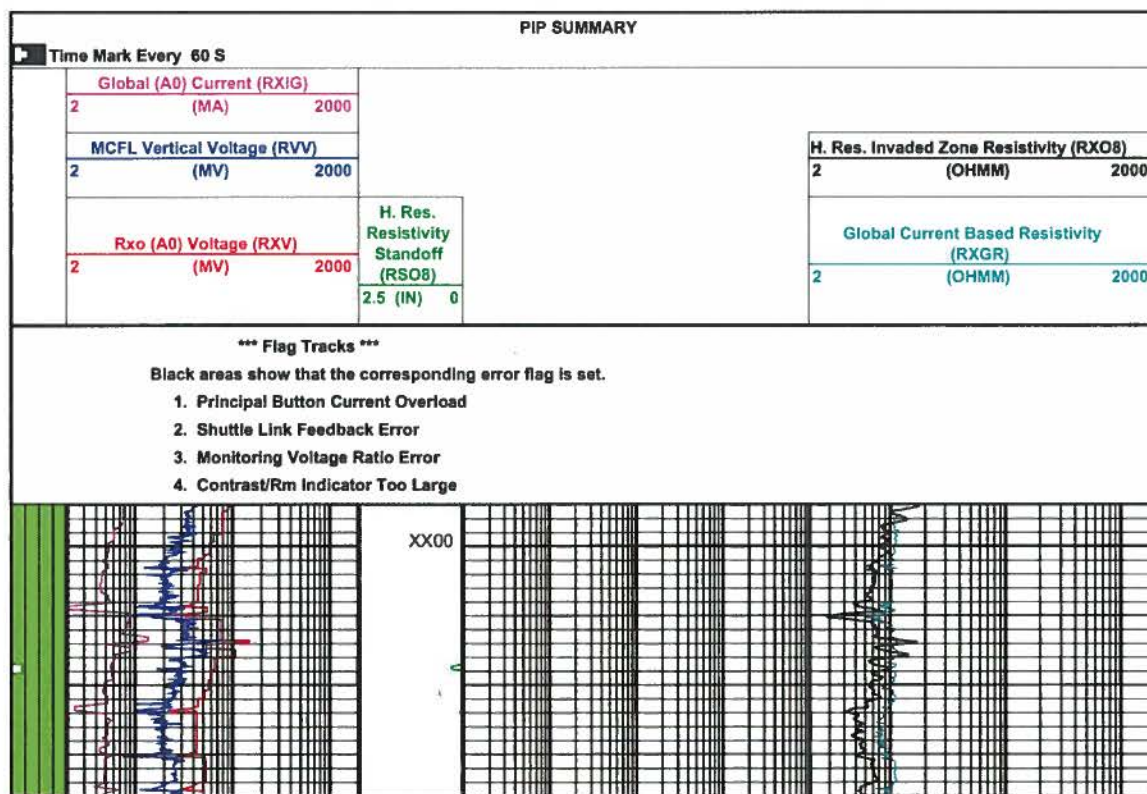

Figure 4. MCFL standard format for hardware.

The MCFL processing format is in Fig. 5.

- Track 1
 - ERBR[n] for the response of each button is used to determine how close the reconstructed measurements are to the actual ones. High error values can indicate abnormal noise level, non-homogeneous R_{xo} value, or standoff resulting from sonde tilt.
- Track 2
 - ERXO, ERMC, and EHMR confidence indicators for R_{xo} , R_{mc} , and mudcake thickness, respectively, indicate the amount of error associated with the results of the MCFL inversion. These curves should remain close to zero.
- Track 3
 - HDRX applied to the main button to match the inverted output RXOZ should range between 0.5 and 1.5.

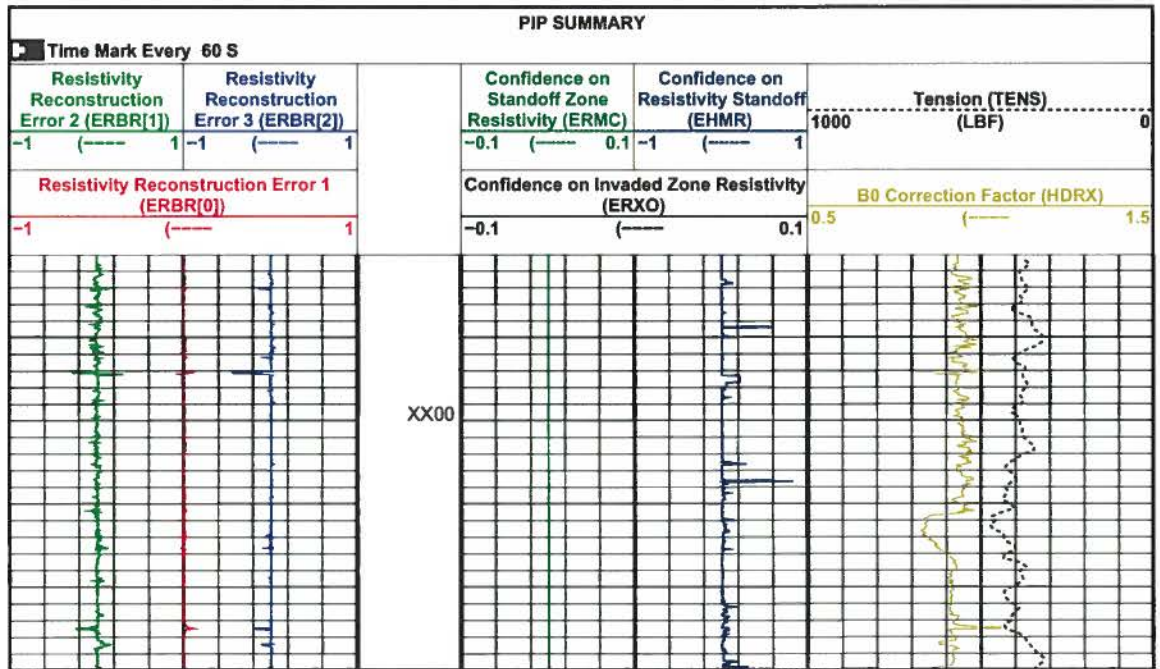

Figure 5. MCFL standard format for processing.

Response in known conditions

HGNS neutron response

The values in Table 3 assume that the matrix parameter is set to limestone (MATR = LIME), hole is in gauge, and borehole corrections are applied.

HRDD density response

Typical values for the HRDD response are in Table 4.

MCFL microresistivity response

- In impermeable zones, the R_{xo} curve should equal the induction or resistivity measurements.
- In permeable zones, the R_{xo} curve should show a coherent profile as an indication of invasion.

AIT and HALS resistivity response

- In impermeable zones, the resistivity curves should overlay.
- In permeable zones, the relative position of the curves should show a coherent profile depending on the values of the resistivity of the mud filtrate (R_{mf}) and the resistivity of the water (R_w), the respective saturation, and the depth of invasion. In salt muds, generally the invasion profile is such that deeper-reading curves have a higher value than shallower-reading curves, with deep investigation curves approaching the true formation resistivity (R_t) and shallow investigation curves approaching R_{xo} .

Table 3. Typical HGNS Response in Known Conditions

Formation	NPHI, [†] V/V	TNPH or NPOR, [‡] V/V
Sandstone, 0% porosity	-1.7	-2.0
Limestone, 0% porosity	0	0
Dolomite, 0% porosity	2.4	0.7
Sandstone, 20% porosity [§]	15.8 if formation salinity = 0 ug/g	15.1 if formation salinity = 250 ug/g
Limestone, 20% porosity	20.0	20.0
Dolomite, 20% porosity [§]	27.2 if formation salinity = 0 ug/g	22.6 if formation salinity = 0 ug/g 24.1 if formation salinity = 250 ug/g
Anhydrite	-0.2	-2.0
Salt	-0.0	-3.0
Coal	38 to 70	28 to 70
Shale	30 to 60	30 to 60

[†] After borehole correction with MATR = LIME. Refer to Chart CP-1c in Schlumberger *Log Interpretation Charts*.

[‡] After borehole correction with MATR = LIME. Refer to Charts CP-1e and -1f in Schlumberger *Log Interpretation Charts*.

[§] The reason that sandstone or dolomite with a porosity of 20% reads differently after environmental correction with MATR = LIME for different formation salinities is that the formation salinity correction is matrix dependant, and a formation salinity correction made assuming MATR = LIME is incorrect if the matrix is different. Refer to Chart Por-13b in Schlumberger *Log Interpretation Charts*.

Table 4. Typical HRDD Response in Known Conditions

Formation	RHOB, g/cm ³	PEF [†]
Sandstone, 0% porosity	2.65 to 2.68	1.81
Limestone, 0% porosity	2.71	5.08
Dolomite, 0% porosity	2.87	3.14
Anhydrite	2.98	5.05
Salt	2.04	4.65
Coal	1.2 to 1.7	0.2
Shale	2.1 to 2.8	1.8 to 6.3

[†] PEF readings are restricted to not read below 0.8.

PS Platform

Overview

The PS Platform* production services platform uses a modular design comprising the following main tools:

- Platform Basic Measurement Sonde (PBMS) for measuring pressure, temperature, gamma ray, and casing collar location
- Gradiomanometer* (PGMC) sonde for measuring the density of the well fluid and well deviation
- PS Platform Inline Spinner (PILS) for measuring high-velocity flow in small-diameter tubulars
- Flow-Caliper Imaging Sonde (PFCS) for measuring fluid velocity and water holdup and also has a dual-axis caliper.

Additional production logging tools combinable with the PS Platform system are

- GHOST* gas optical holdup sensor tool for measuring gas holdup and also has a caliper
- Digital Entry and Fluid Imaging Tool (DEFT) for measuring water and also has a caliper
- Flow Scanner* horizontal and deviated well production logging system for measuring three-phase flow rate in horizontal wells
- RST* reservoir saturation tool for measuring water velocity and three-phase holdup.

Also combinable with the PS Platform system are

- SCMT* slim cement mapping tool for a through-tubing cement quality log
- PS Platform Multifinger Imaging Tool (PMIT) for multifinger caliper surveys of pitting and erosion
- EM Pipe Scanner* electromagnetic casing inspection tool for electromagnetic inspection of corrosion and erosion
- RST reservoir saturation tool for capture sigma saturation logging, carbon/oxygen saturation logging, capture lithology identification, and silicon-activation gravel-pack quality logging.

In horizontal wells the PBMS can be replaced by the MaxTRAC* down-hole well tractor system or the TuffTRAC* cased hole services tractor.

RST and RSTPro

Overview

The dual-detector spectrometry system of the through-tubing RST* and RSTPro* reservoir saturation tools enables the recording of carbon and oxygen and Dual-Burst* thermal decay time measurements during the same trip in the well.

The carbon/oxygen (C/O) ratio is used to determine the formation oil saturation independent of the formation water salinity. This calculation is particularly helpful if the water salinity is low or unknown. If the salinity of the formation water is high, the Dual-Burst measurement is used. A combination of both measurements can be used to detect and quantify the presence of injection water of a different salinity from that of the connate water.

Specifications

Measurement Specifications	
	RST and RSTPro Tools
Output	Inelastic and capture yields of various elements, carbon/oxygen ratio, formation capture cross section (sigma), porosity, borehole holdup, water velocity, phase velocity, SpectroLith* processing
Logging speed [†]	Inelastic mode: 100 ft/h [30 m/h] (formation dependent) Capture mode: 600 ft/h [183 m/h] (formation and salinity dependent) RST sigma mode: 1,800 ft/h [549 m/h] RSTPro sigma mode: 2,800 ft/h [850 m/h]
Range of measurement	Porosity: 0 to 60 V/V
Vertical resolution	15 in [38.10 cm]
Accuracy	Based on hydrogen index of formation
Depth of investigation [‡]	Sigma mode: 10 to 16 in [20.5 to 40.6 cm] Inelastic capture (IC) mode: 4 to 6 in [10.2 to 15.2 cm]
Mud type or weight limitations	None
Combinability	RST tool: Combinable with the PL Flagship* system and CPLT* combinable production logging tool RSTPro tool: Combinable with tools that use the PS Platform* telemetry system and Platform Basic Measurement Sonde (PBMS)

[†] See Tool Planner application for advice on logging speed.

[‡] Depth of investigation is formation and environment dependent.

Calibration

The master calibration of the RST and RSTPro tools is conducted annually to eliminate tool-to-tool variation. The tool is positioned within a polypropylene sleeve in a horizontally positioned calibration tank filled with chlorides-free water.

The sigma, WFL* water flow log, and PVL* phase velocity log modes of the RST and RSTPro detectors do not require calibration. The gamma ray detector does not require calibration either.

Mechanical Specifications		
	RST-A and RST-C	RST-B and RST-D
Temperature rating	302 degF [150 degC] With flask: 400 degF [204 degC]	302 degF [150 degC]
Pressure rating	15,000 psi [103 MPa] With flask: 20,000 psi [138 MPa]	15,000 psi [103 MPa]
Borehole size—min.	1 ³ / ₁₆ in [4.60 cm] With flask: 2 ¹ / ₄ in [5.72 cm]	2 ¹ / ₄ in [7.30 cm]
Borehole size—max.	9 ⁵ / ₁₆ in [24.45 cm] With flask: 9 ⁵ / ₁₆ in [24.45 cm]	9 ⁵ / ₁₆ in [24.45 cm]
Outside diameter	1.71 in [4.34 cm] With flask: 2.875 in [7.30 cm]	2.51 in [6.37 cm]
Length	23.0 ft [7.01 m] With flask: 33.6 ft [10.25 m]	22.2 ft [6.76 m]
Weight	101 lbm [46 kg] With flask: 243 lbm [110 kg]	208 lbm [94 kg]
Tension	10,000 lbf [44,480 N] With flask: 25,000 lbf [111,250 N]	10,000 lbf [44,480 N]
Compression	1,000 lbf [4,450 N] With flask: 1,800 lbf [8,010 N]	1,000 lbf [4,450 N]

Tool quality control

Standard curves

The RST and RSTPro standard curves are listed in Table 1.

Table 1. RST and RSTPro Standard Curves

Output Mnemonic	Output Name
BADL_DIAG	Bad level diagnostic
CCRA	RST near/far instantaneous count rate
COR	Carbon/oxygen ratio
CRRA	Near/far count rate ratio
CRRR	Count rate regulation ratio
DSIG	RST sigma difference
FBAC	Multichannel Scaler (MCS) far background
FBEF	Far beam effective current
FCOR	Far carbon/oxygen ratio
FEF	Far capture gain correction factor
FEF	Far capture offset correction factor
FERD	Far capture resolution degradation factor (RDF)
FIGF	Far inelastic gain correction
FIOF	Far inelastic offset correction factor
FIRD	Far inelastic RDF
IC	Inelastic capture
IRAT_FIL	RST near/far inelastic ratio
NBEF	Near beam effective current
NCOR	Near carbon/oxygen ratio
NEGF	Near capture gain correction factor
NEOF	Near capture offset correction factor
NERD	Near capture RDF
NIGF	Near inelastic gain correction
NIOF	Near inelastic offset correction factor
NIRD	Near inelastic RDF
RSCF_RST	RST selected far count rate
RSCN_RST	RST selected near count rate
SBNA	Sigma borehole near apparent
SFFA_FIL	Sigma formation far apparent
SFNA_FIL	Sigma formation near apparent
SIGM	Formation sigma
SIGM_SIG	Formation sigma uncertainty
TRAT_FIL	RST near/far capture ratio

Operation

The RST and RSTPro tools should be run eccentered. The main inelastic capture characterization database does not support a centered tool, thus it is important to ensure that the tool is run eccentered. However, for a WFL water flow log, a centered tool is recommended to better evaluate the entire wellbore region.

Formats

The format in Fig. 1 is used mainly as a hardware quality control.

- Depth track
 - Deflection of the BADL_DIAG curve by 1 unit indicates that frame data are being repeated (resulting from fast logging speed or stalled data). A deflection by 2 units indicates bad spectral data (too-low count rate).
- Track 1
 - CRRA, CRRR, NBEF, and FBEF are shown; FBEF should track openhole porosity when properly scaled.
- Track 6
 - The IC mode gain correction factors measure the distortion of the energy inelastic and elastic spectrum in the near and far detectors relative to laboratory standards. They should read between 0.98 and 1.02.
- Track 7
 - The IC mode offset correction factors are described in terms of gain, offset, and resolution degradation of the inelastic and elastic spectrum in the near and far detectors. They should read between -2 and 2.
- Track 8
 - Distortion on these curves affects inelastic and capture spectra from the near and far detectors. They should be between 0 and 15. Anything above 15 indicates a tool problem or a tool that is too hot (above 302 degF [150 degC]), which affects yield processing.

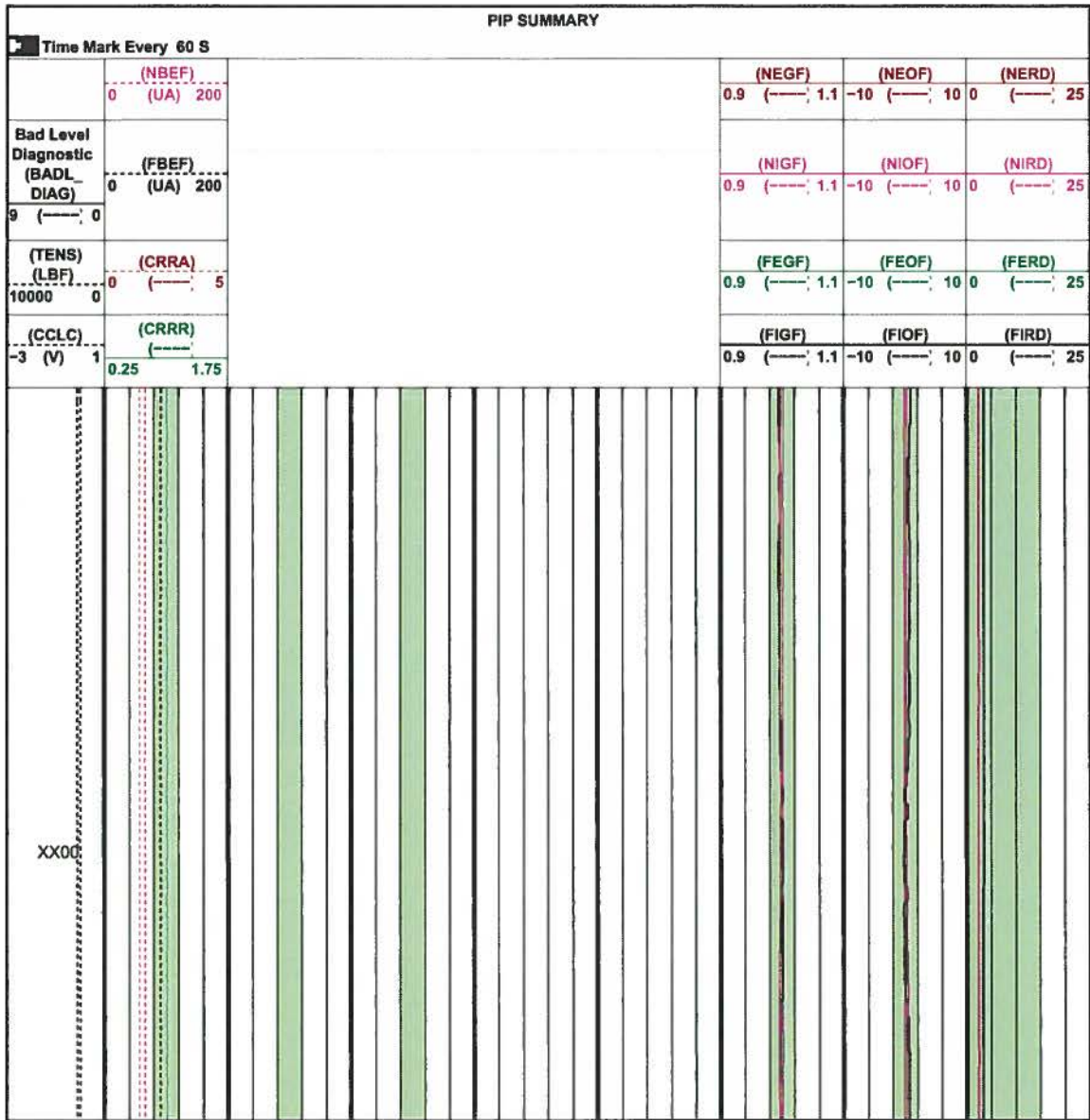

Figure 1. RST and RSTPro hardware format.

The format in Fig. 2 is used mainly for sigma quality control.

- Depth track
 - Deflection of the BADL_DIAG curve by 1 unit indicates that frame data are being repeated (resulting from fast logging speed or stalled data). A deflection by 2 units indicates bad spectral data (too-low count rate).
- Tracks 2 and 3
 - The IRAT_FIL inelastic ratio increases in gas and decreases with porosity.
 - DSIG in a characterized completion should equal approximately zero. Departures from zero indicate either the environmental parameters are set incorrectly or environment is different from the characterization database (e.g., casing is not fully centered in the wellbore or the tool is not eccentered). Shales typically read 1 to 4 units from the baseline of zero because they are not characterized in the database.

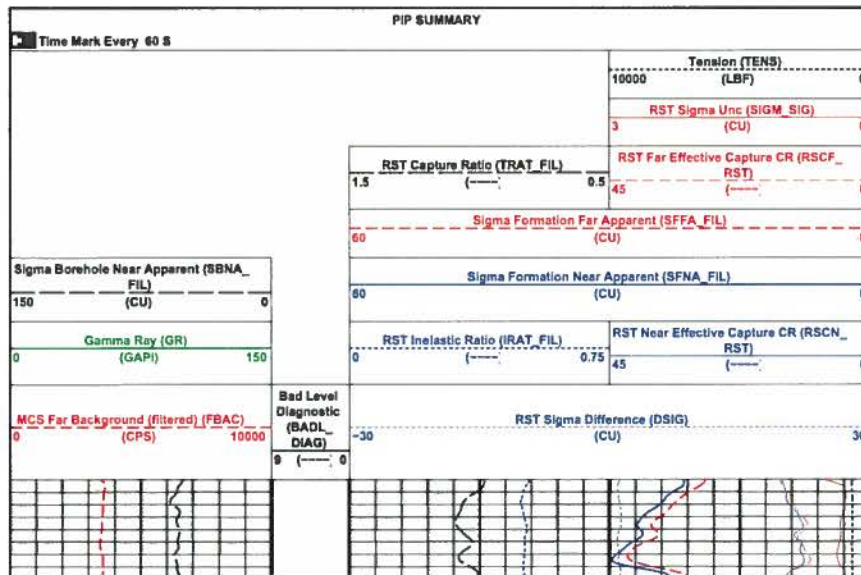

Figure 2. RST and RSTPro sigma standard format.

Response in known conditions

In front of a clean water zone, COR is smaller than the value logged across an oil zone. Oil in the borehole affects both the near and far COR, causing them to read higher than in a water-filled borehole. In front of shale, high COR is associated with organic content.

The computed yields indicate contributions from the materials being measured (Table 2).

Table 2. Contributing Materials to RST and RSTPro Yields

Element	Contributing Material
C and O	Matrix, borehole fluid, formation fluid
Si	Sandstone matrix, shale, cement behind casing
Ca	Carbonates, cement
Fe	Casing, tool housing

Bad cement quality affects readings (Table 3). A water-filled gap in the cement behind the casing appears as water to the IC measurement. Conversely, an oil-filled gap behind the casing appears as oil to the IC measurement.

Table 3. RST and RSTPro Capture and Sigma Modes

Medium	Sigma, cu
Oil	18 to 22
Gas	0 to 12
Water, fresh	20 to 22
Water, saline	22 to 120
Matrix	8 to 12
Shale	35 to 55

Cement Bond Tool

Overview

The cement bond log (CBL) made with the Cement Bond Tool (CBT) provides continuous measurement of the attenuation of sound pulses, independent of casing fluid and transducer sensitivity. The tool is self-calibrating and less sensitive to eccentricity and sonde tilt than the traditional single-spacing CBL tools. The CBT additionally gives the attenuation of sound pulses from a receiver spaced 0.8 ft [0.24 m] from the transmitter, which is used to aid interpretation in fast formations.

A CBL curve computed from the three attenuations available enables comparison with CBLs based on the typical 3-ft [0.91-m] spacing. This computed CBL continuously discriminates between the three attenuations to choose the one best suited to the well conditions. An interval transit-time curve for the casing is also recorded for interpretation and quality control.

A Variable Density* log (VDL) is recorded simultaneously from a receiver spaced 5 ft [1.52 m] from the transmitter. This display provides information on the cement/formation bond and other factors that are important to the interpretation of cement quality.

Specifications

Measurement Specifications	
Output	Attenuation measurement, CBL, VDL image, transit times
Logging speed	1,800 ft/h [549 m/h] [†]
Range of measurement	Formation and casing dependent
Vertical resolution	CBL: 3 ft [0.91 m] VDL: 5 ft [1.52 m] Cement map: 2 ft [0.61 m]
Accuracy	Formation and casing dependent
Depth of investigation	CBL: casing and cement interface VDL: depends on bonding and formation
Mud type or weight limitations	None

[†] Speed can be reduced depending on data quality.

Measurement Specifications	
Temperature rating	350 degF [177 degC]
Pressure rating	20,000 psi [138 MPa]
Borehole size—min.	3.375 in [8.57 cm]
Borehole size—max.	13.375 in [33.97 cm]
Outside diameter	2.75 in [6.985 cm]
Weight	309 lbm [140 kg]

Calibration

Sonde normalization of sonic cement bond tools is performed with every Q-check. Q-check frequency is also dependent on the number of jobs run, exposure to high temperature, and other factors.

The sonic checkout setup used for calibration is supported with two stands, one on each end. A stand in the center of the tube would distort the waveform and cause errors. One end of the tube is elevated to assist in removing all air in the system, and the tool is positioned in the tube with centralizer rings.

Tool quality control

Standard curves

CBT standard curves are listed in Table 1.

Table 1. CBT Standard Curves

Output Mnemonic	Output Name
CCL	Casing collar locator amplitude
DATN	Discriminated BHC attenuation
DBI	Discriminated bond index
DCBL	Discriminated synthetic CBL
DT	Interval transit time of casing (delta-t)
DTMD	Delta-t mud (mud slowness)
GR	Gamma ray
NATN	Near 2.4-ft attenuation
NBI	Near bond index
NCBL	Near synthetic CBL
R32R	Ratio of receiver 3 sensitivity to receiver 2 sensitivity, dB
SATN	Short 0.8-ft attenuation [†]
SB1	Short bond index [†]
SCBL	Short synthetic CBL [†]
TT1	Transit time for mode 1 (upper transmitter, receiver 3 [UT-R3])
TT2	Transit time for mode 2 (UT-R2)
TT3	Transit time for mode 3 (lower transmitter, receiver 2 [LT-R2])
TT4	Transit time for mode 4 (LT-R3)
TT6	Transit time for mode 6 (UT-R1)
ULTR	Ratio of upper transmitter output strength to the lower transmitter output strength
VDL	Variable Density log

[†] In fast formations only

Operation

The tool should be run centralized.

A log should be made in a free-pipe zone (if available). Where a micro-annulus is suspected, a repeat section should be made with pressure applied to the casing.

Formats

The format in Fig. 1 is used both as an acquisition and quality control format.

- Track 1
 - DT and DTMD are derived from the transit-time measurements from all transmitter-receiver pairs. They respond to eccentricization of any of the six measurements modes and are a sensitive indicator of wellbore conditions. In a low-quality cement bond or free pipe, both readings are correct. In well-bonded sections, the transit time may cycle skip, affecting the DT and DTMD values.
 - CCL deflects in front of casing collars.
 - GR is used for correlation purposes.

- Track 2
 - DCBL is related to casing size, casing weight, and mud. As a quality control DCBL should be checked against the expected responses in known conditions (see the following section). Also, DCBL should match the VDL image readings.
- Track 3
 - VDL is a map of the waveform amplitude versus depth and it should have good contrast. It provides information on the cement/formation bond, which is important for cement quality interpretation. The VDL image should be cross checked that it matches the DCBL readings. For example, in a free-pipe section, the DCBL amplitude reads high and VDL shows strong casing arrivals with no formation arrivals. In a zone of good bond for the casing to the formation, the CBL amplitude reads low and the VDL has weak casing arrivals and clear formation arrivals.

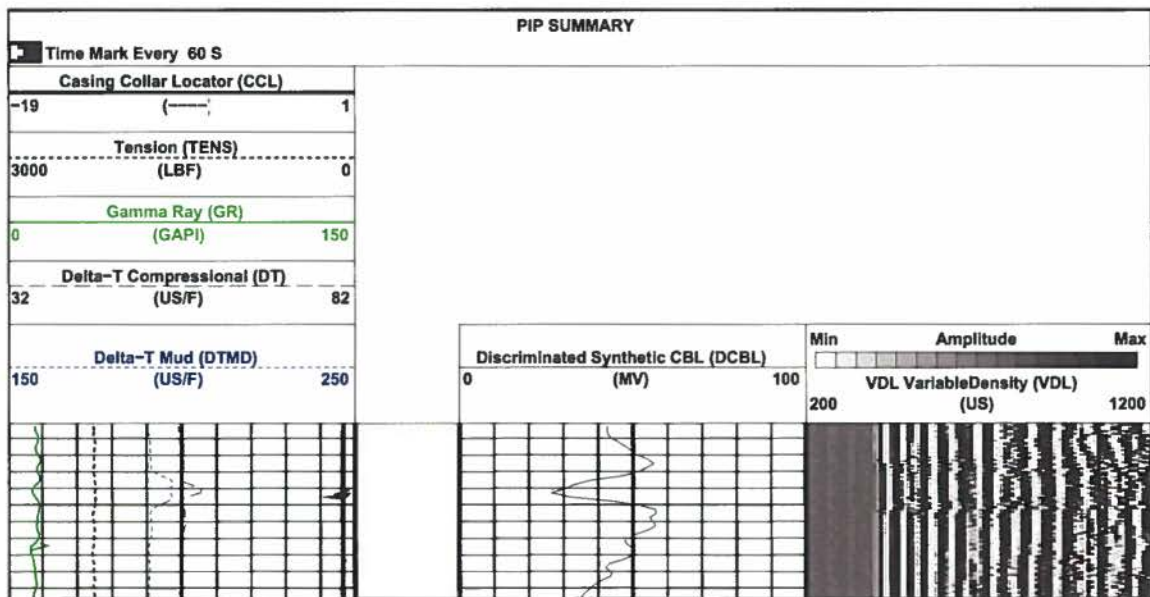

Figure 1. CBT standard format for CBL and VDL.

The format in Fig. 2 is also used both as an acquisition and quality control format.

- Track 1
 - The transit time pairs should overlay (TT1C overlays TT3C, and TT2C overlays TT4C) because these pairs are derived from equivalent transmitter-receiver spacings. In very good cement sections, the transit-time curve may be affected by cycle skipping. DT and DTMD may be also affected.
- Track 2
 - The ULTR and R32R ratios are quality indicators of the transmitter or receiver strengths. They should be $0 \text{ dB} \pm 3 \text{ dB}$, unless one of the transmitters or receivers is weak. Both curves should be checked for consistency and stability.

- Track 3
 - DATN should equal NATN in free-pipe sections. In the presence of cement behind casing and in normal conditions, NATN reads higher than DATN.
- Track 4
 - VDL is a map of the waveform amplitude versus depth that should have good contrast. It provides information on the cement/formation bond, which is important for cement quality interpretation. The VDL image should be cross checked that it matches the DCBL readings.

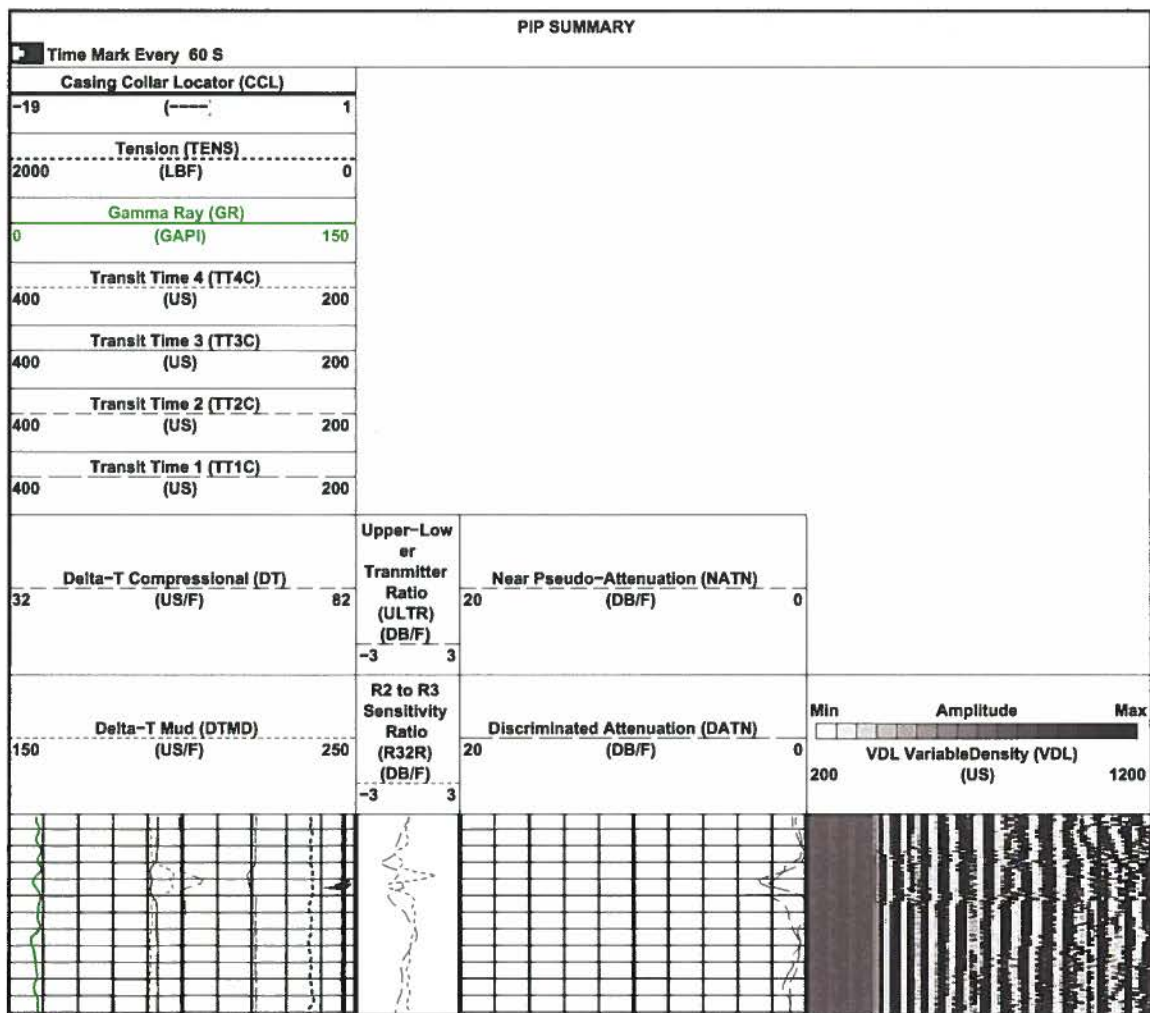

Figure 2. Additional CBT standard format for CBL and VDL.

Response in known conditions

- DT in casing should read the value for steel (57 us/ft \pm 2 us/ft [187 us/m \pm 6.6 us/m]).
- DTMD should be compared with known velocities (water-base mud: 180–200 us/ft [590–656 us/m], oil-base mud: 210–280 us/ft [689–919 us/m]).
- Typical responses for different casing sizes and weights are listed in Table 2.

Table 2. Typical CBT Response in Known Conditions

Casing Size, in	Casing Weight, lbm/ft	DCBL in Free Pipe, mV	TT1, us	TT2, us	TT5, us
4.5	11.6	84 \pm 8	252	195	104
5	13	77 \pm 7	259	203	112
5.5	17	71 \pm 7	267	210	120
7	24	61 \pm 6	290	233	140
8.625	38	55 \pm 6	314	257	166
9.625	40 [†]	52 \pm 5	329	272	NM [‡]

[†] Although the CBT operates in up to 13¾-in casing, the VOL presentation mainly shows casing arrivals where casings of 9¾ in and larger are logged.

[‡] NM = not meaningful

Cement Bond Logging

Overview

Cement bond tools measure the bond between the casing and the cement placed in the annulus between the casing and the wellbore. The measurement is made by using acoustic sonic and ultrasonic tools. In the case of sonic tools, the measurement is usually displayed on a cement bond log (CBL) in millivolt units, decibel attenuation, or both. Reduction of the reading in millivolts or increase of the decibel attenuation is an indication of better-quality bonding of the cement behind the casing to the casing wall. Factors that affect the quality of the cement bonding are

- cement job design and execution as well as effective mud removal
- compressive strength of the cement in place
- temperature and pressure changes applied to the casing after cementing
- epoxy resin applied to the outer wall of the casing.

The recorded CBL provides a continuous measurement of the amplitude of sound pulses produced by a transmitter-receiver pair spaced 3-ft [0.91-m] apart. This amplitude is at a maximum in uncemented free pipe and minimized in well-cemented casing. A transit-time (TT) curve of the waveform first arrival is also recorded for interpretation and quality control.

A Variable Density* log (VDL) is recorded simultaneously from a receiver spaced 5 ft [1.52 m] from the transmitter. The VDL display provides information on the cement quality and cement/formation bond.

Specifications

Measurement Specifications		
	Digital Sonic Logging Tool (DSL) and Hostile Environment Sonic Logging Tool (HSLT) with Borehole-Compensated (BHC)	Slim Array Sonic Tool (SSLT) and SlimXtreme* Sonic Logging Tool (QSLT)
Output	SLS-C, SLS-D, SLS-W, and SLS-E: [†] 3-ft [0.91-m] CBL Variable Density waveforms	3-ft [0.91-m] CBL and attenuation 1-ft [0.30-m] attenuation 5-ft [1.52-m] Variable Density waveforms
Logging speed	3,600 ft/h [1,097 m/h]	3,600 ft/h [1,097 m/h]
Range of measurement	40 to 200 us/ft [131 to 656 us/m]	40 to 400 us/ft [131 to 1,312 us/m]
Vertical resolution	Amplitude (mV): 3 ft [0.91 m] VDL: 5 ft [1.52 m]	Near attenuation: 1 ft [0.30 m] Amplitude (mV): 3 ft [0.91 m] VDL: 5 ft [1.52 m]
Depth of investigation	Synthetic CBL from discriminated attenuation (DCBL): Casing and cement interface VDL: Depends on cement bonding and formation properties	DCBL: Casing and cement interface VDL: Depends on cement bonding and formation properties
Mud type or weight limitations	None	None
Special applications		Conveyed on wireline, drillpipe, or coiled tubing Logging through drillpipe and tubing, in small casings, fast formations

[†] The DSLT uses the Sonic Logging Sonde (SLS) to measure cement bond amplitude and VDL evaluation.

Mechanical Specifications

	DSL T	HSL T	SSL T	QSL T
Temperature rating	302 degF [150 degC]	500 degF [260 degC]	302 degF [150 degC]	500 degF [260 degC]
Pressure rating	20,000 psi [138 MPa]	25,000 psi [172 MPa]	14,000 psi [97 MPa]	30,000 psi [207 MPa]
Casing ID—min.	5 in [12.70 cm]	5 in [12.70 cm]	3½ in [8.89 cm]	4 in [10.16 cm]
Casing ID—max.	18 in [45.72 cm]	18 in [45.72 cm]	8 in [20.32 cm]	8 in [20.32 cm]
Outside diameter	3¾ in [9.21 cm]	3¾ in [9.53 cm]	2½ in [6.35 cm]	3 in [7.62 cm]
Length	SLS-C and SLS-D: 18.7 ft [5.71 m] SLS-E and SLS-W: 20.6 ft [6.23 m]	With HSL S-W sonde: 25.5 ft [7.77 m]	23.1 ft [7.04 m] With inline centralizers: 29.6 ft [9.02 m]	23 ft [7.01 m] With inline centralizers: 29.9 ft [9.11 m]
Weight	SLS-C and SLS-D: 273 lbm [124 kg] SLS-E and SLS-W: 313 lbm [142 kg]	With HSL S-W sonde: 440 lbm [199 kg]	232 lbm [105 kg] With inline centralizers: 300 lbm [136 kg]	295 lbm [134 kg] With inline centralizers: 407 lbm [185 kg]
Tension	29,700 lbf [132,110 N]	29,700 lbf [132,110 N]	13,000 lbf [57,830 N]	13,000 lbf [57,830 N]
Compression	SLS-C and SLS-D: 1,700 lbf [7,560 N] SLS-E and SLS-W: 2,870 lbf [12,770 N]	With HSL S-W sonde: 2,870 lbf [12,770 N]	4,400 lbf [19,570 N]	4,400 lbf [19,570 N]

Calibration

Sonde normalization of sonic cement bond tools is performed with every Q-check. Scheduled frequency of Q-checks varies for each tool. Q-check frequency is also dependent on the number of jobs run, exposure to high temperature, and other factors.

The sonic checkout setup used for calibration is supported with two stands, one on each end. A stand in the center of the tube would distort the waveform and cause errors. One end of the tube is elevated to assist in removing all air in the system, and the tool is positioned in the tube with centralizer rings.

Tool quality control

Standard curves

CBL standard curves are listed in Table 1.

Table 1. CBL Standard Curves

Output Mnemonic	Output Name
BI	Bond index
CBL	Cement bond log (fixed gate)
CBLF	Fluid-compensated cement bond log
CBSL	Cement bond log (sliding gate)
CCL	Casing collar log
GR	Gamma ray
TT	Transit time (fixed gate)
TTSL	Transit time (sliding gate)
VDL	Variable Density log

Operation

The tool must be run centralized.

A log should be made in a free-pipe zone (if available). Where a micro-annulus is suspected, a repeat section should be made with pressure applied to the casing.

Formats

The format in Fig. 1 is used for both acquisition and quality control.

- Track 1
 - TT and TTSL should be constant through the log interval and should overlay. These curves deflect near casing collars. In sections of very good cement, the signal amplitude is low; detection may be affected by cycle skipping. GR is used for correlation purposes, and CCL serves as a reference for future cased hole correlations..
- Track 2
 - CBL measured in millivolts from the fixed gate should be equal to CBSL measured from the sliding gate, except in cases of cycle skipping or detection on noise.
- Track 3
 - VDL is a presentation of the acoustic waveform at a receiver of a sonic measurement. The amplitude is presented in shades of a gray scale. The VDL should show good contrast. In free pipe, it should be straight lines with chevron patterns at the casing collars. In a good bond, it should be gray (low amplitudes) or show strong formation signals (wavy lines).

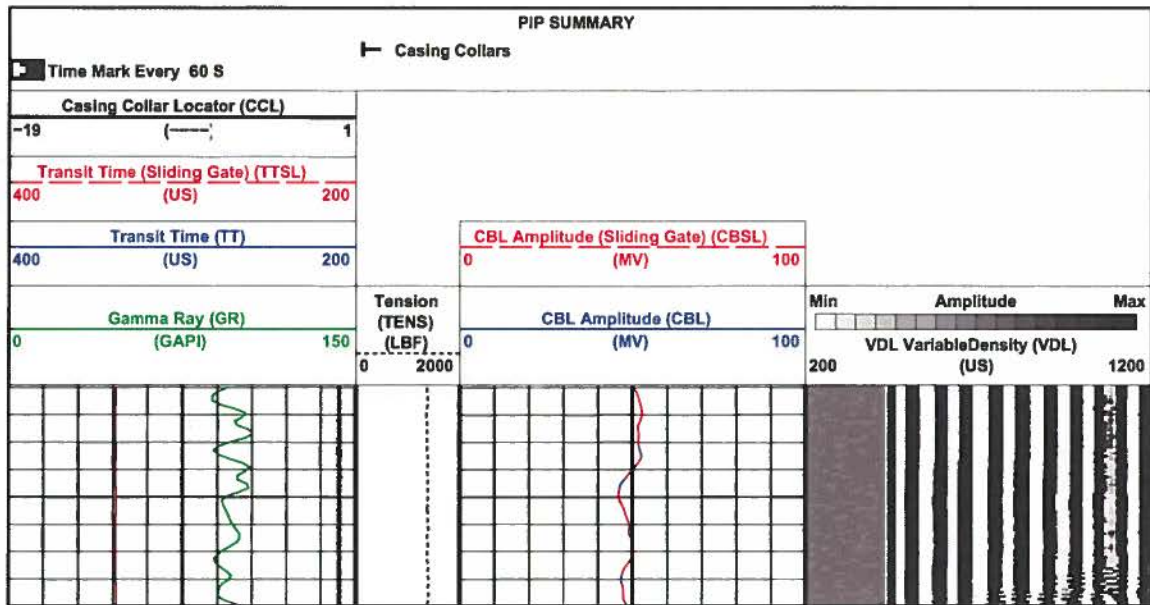

Figure 1. DSLT standard format.

Response in known conditions

The responses in Table 2 are for clean, free casing.

Table 2. Typical CBL Response in Known Conditions

Casing OD, in	Weight, lbm/ft	Nominal Casing ID, in	CBL Amplitude Response in Free Pipe, mV
5	13	4.494	77 ± 8
5.5	17	4.892	71 ± 7
7	23	6.366	62 ± 6
8.625	36	7.825	55 ± 6
9.625	47	8.681	52 ± 5
10.75	51	9.850	49 ± 5
13.375	61	12.515	43 ± 4
18.625	87.5	17.755	35 ± 4

USI

Overview

The USI* ultrasonic imager tool (USIT) uses a single transducer mounted on an Ultrasonic Rotating Sub (USRS) on the bottom of the tool. The transmitter emits ultrasonic pulses between 200 and 700 kHz and measures the received ultrasonic waveforms reflected from the internal and external casing interfaces. The rate of decay of the waveforms received indicates the quality of the cement bond at the cement-to-casing interface, and the resonant frequency of the casing provides the casing wall thickness required for pipe inspection.

Because the transducer is mounted on the rotating sub, the entire circumference of the casing is scanned. This 360° data coverage enables evaluation of the quality of the cement bond as well as determination of the internal and external casing condition. The very high angular and vertical resolutions can detect channels as narrow as 1.2 in [3.05 cm]. Cement bond, thickness, internal and external radii, and self-explanatory maps are generated in real time at the wellsite.

Specifications

Measurement Specifications	
Output	Acoustic impedance, cement bonding to casing, internal radius, casing thickness
Logging speed	400 to 3,600 ft/h [†] [122 to 1,097 m/h]
Range of measurement	Acoustic impedance: 0 to 10 Mrayl [0 to 10 MPa.s/m]
Vertical resolution	Standard: 6 in [15.24 cm]
Accuracy	Less than 3.3 Mrayl: ±0.5 Mrayl
Depth of investigation	Casing-to-cement interface
Mud type or weight limitations [‡]	Water-base mud: Up to 15.9 lbm/galUS Oil-base mud: Up to 11.2 lbm/galUS
Combinability	Bottom-only tool, combinable with most tools
Special applications	Identification and orientation of narrow channels

[†] Speed depends on the resolution selected.

[‡] Exact value depends on the type of mud system and casing size.

Calibration

There is no calibration for the USI tool. The fluid properties measurement (FPM) of the wellbore fluid impedance (AIBK) and the fluid slowness (FVEL) is used for early input into the impedance model. The thickness of the subassembly reference plate (THBK) is also measured and output with FPM. FPM is recorded versus time while running in hole and output both as a time-depth log and as crossplots of FVEL versus depth and AIBK versus depth.

A before-survey tool check is conducted to verify basic tool operation.

Mechanical Specifications	
Temperature rating	350 degF [177 degC]
Pressure rating	20,000 psi [138 MPa]
Casing size—min.	4½ in [11.43 cm]
Casing size—max.	13¾ in [33.97 cm]
Outside diameter	3.375 in [8.57 cm]
Length [†]	19.75 ft [6.02 m]
Weight [†]	333 lbm [151 kg]
Tension	40,000 lbf [177,930 N]
Compression	4,000 lbf [17,790 N]

[†] Excluding the rotating sub

Tool quality control

Standard curves

The USI standard curves are listed in Table 1.

Table 1. USI Standard Curves

Output Mnemonic	Output Name
AIBK	Acoustic impedance fluid properties measurement (FPM)
AVMN	Minimum amplitude
AWAZ	Average amplitude
AWMX	Maximum amplitude
AZEC	Azimuth of eccentricity
ECCE	Tool eccentricity
ERAV	Average external radius
ERMN	Minimum external radius
ERMX	Maximum external radius
FVEL	Fluid acoustic slowness
FVEM	Fluid velocity FPM
GNMN	Minimum value of automatic gain (UPGA) in 6-in interval
GNMX	Maximum value of UPGA in 6-in interval
HRTT	Transit-time (TT) histogram
IDQC	Internal diameter quality check
IRAV	Average internal radius
IRMN	Minimum internal radius
IRMX	Maximum internal radius
THAV	Average thickness
THBK	Reference plate thickness FPM
THMN	Minimum thickness
THMX	Maximum thickness
USBI	Ultrasonic bond index
USGI	Ultrasonic gas index
WDMN	Waveform delay minimum
WDMX	Waveform delay maximum
WPKA	Waveform peak amplitude histogram

Operation

The USI tool should be run centered. The tool has centralizers in its sonde. Eccentering should be less than 0.02 in [0.508 mm] per inch of casing diameter.

In deviated wells, knuckle joints must be used along with centralizers on tools above in the string.

Cement information is critical for setting the USIT field parameters.

Formats

The format in Fig. 1 is used mainly as a quality control.

- Track 1
 - The WPKA histogram is a distribution of the waveform measured by the USIT transducer. The image scale and color represents the number of samples and their corresponding peak amplitude in binary bits.
- Track 2
 - IDQC should match the actual casing internal diameter.
 - WDMN and WDMX should be within 10 us of each other. The difference is due to casing deformation or tool eccentricity.
- Track 3
 - GNMN and GNMX are the maximum and minimum gains, respectively, in the depth frame and should range between 0 and 10 dB.
- Track 4
 - The HRTT image represents the histogram of the TT measurements on a black background, which corresponds to the positions of the peak detection window. The coherence in the log track is desired; most of the echoes should be inside the window. Measured transit times should be well within the peak detection window in a good hole. If the blue color is out of the detection windows, parameters must be adjusted on the job to the windows.

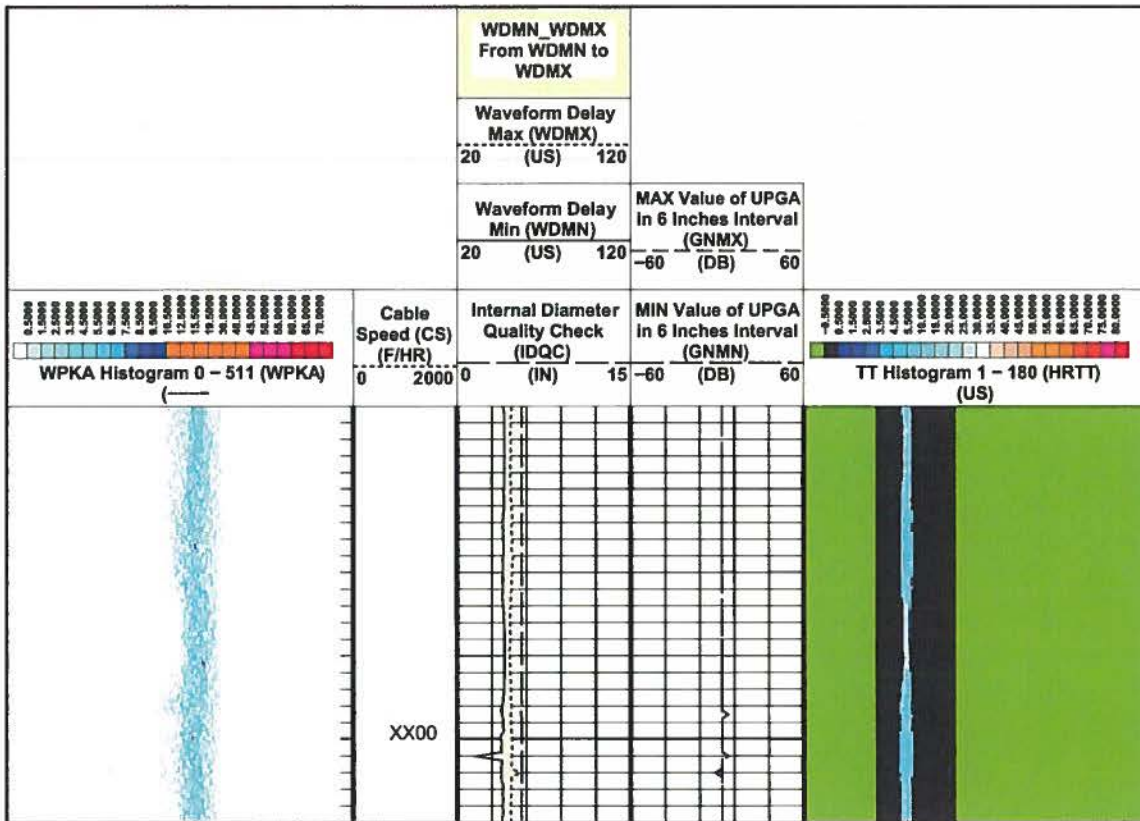

Figure 1. USIT standard format.

Response in known conditions

- The average internal radius and thickness measured by the tool should match the actual nominal internal radius of the casing.
- The expected responses in the measurement mode are listed in Table 2.

Table 2. Typical USI Response in Known Conditions

Formation	Acoustic Impedance, Mrayl
Free gas or gas microannulus	<0.3
Fresh water	1.5
Drilling fluids	1.5 to 3.0
Cement slurries	1.8 to 3.0
LITEFIL* cement (1.4 g/cm ³)	3.7 to 4.3
Neat cement (1.9 g/cm ³)	6.0 to 8.4