

Region 4
U.S. Environmental Protection Agency
Laboratory Services & Applied Science Division
Athens, Georgia

Operating Procedure

Title: Sediment Oxygen Demand

ID: LSASDPROC-507-R6

Issuing Authority: Field Services Branch Supervisor

Effective Date: April 22, 2023

Review Due Date: June 10, 2024

Method Reference: N/A

SOP Author: Mel Parsons

Purpose

The purpose of this procedure is to document both general and specific procedures, methods and considerations to be used and observed when conducting sediment oxygen demand (SOD) and nutrient exchange (NUTX) studies.

Scope/Application

This document describes specific methods to be used by field investigators when conducting SOD and NUTX measurements. On the occasion that field investigators determine any of the procedures described in this section are inappropriate, inadequate or impractical and that another procedure must be used to obtain the desired data, the alternative procedure will be documented in the field logbook, along with a description of the circumstances requiring its use. All documentation in the field logbook will follow LSASD Operating Procedure for Logbooks (LSASDPROC-1002). Mention of trade names or commercial products in this operating procedure does not constitute endorsement or recommendation for use.

TABLE OF CONTENTS

Purpose.....	1
Scope/Application	1
1 General Information	3
1.1 Documentation/Verification	3
1.2 General Background and Considerations	3
1.3 General Precautions	3
1.3.1 Safety	3
1.3.2 Procedural Precautions	4
2 Sediment Oxygen Demand Measurement	4
3 Nutrient Exchange (NUTX).....	8
3.1 Nutrient Exchange Equipment.....	8
3.2 Nutrient Exchange Procedures.....	9
Revision History.....	13
References	13

FIGURES

Figure 1: SOD Chamber.....	7
----------------------------	---

1 General Information

1.1 Documentation/Verification

This procedure was prepared by persons deemed technically competent by LSASD management, based on their knowledge, skills and abilities and has been tested in practice and reviewed in print by a subject matter expert. The official copy of this procedure resides on the LSASD Local Area Network (LAN). The Document Control Coordinator (DCC) is responsible for ensuring the most recent version of the procedure is placed on the LAN and for maintaining records of review conducted prior to its issuance.

1.2 General Background and Considerations

Sediment oxygen demand measurements are typically conducted utilizing cylindrical opaque chambers approximately 18 - 24 inches in diameter. Smaller diameter opaque chambers or cores may also be utilized, provided SOD rates obtained are verified to be statistically similar to the larger chamber rates. Typically, when conducting SODs from a boat, two replicates for water column respiration and four replicates for sediment respiration rates are deployed. The boat must be on a secure 3 or 4 point anchorage to avoid pulling the chambers off the bottom during the course of the study. When conducting SODs in small streams, where equipment must be carried in and placed by hand, typically one water column respiration chamber and two sediment contact chambers are utilized.

Chambers are carefully placed on the bottom, sealed and a dissolved oxygen (DO) probe is placed inside the chamber. The DO concentration within the chamber is monitored and recorded every 5 to 15 minutes in order to document the rate of utilization of oxygen by the sediments. Twelve to twenty-four readings over a period of 1.5 to 2 hours are generally sufficient to develop a regression to determine the SOD rate of the sediments. Station locations are determined and recorded in accordance to LSASD's Procedure for Global Positioning System (LSASDPROC-110)

1.3 General Precautions

1.3.1 Safety

Sediment oxygen demand measurements may be conducted in a variety of water bodies from small fresh-water streams to large estuarine systems. Due to the physical size of the measurement chambers, water depths need to be a least two feet to ensure that the chambers are adequately submerged. In small wadeable streams, chambers may be carried out by two people and set in place. Great care must be taken not to disturb the sediment surface to be covered by the chambers during this process. Once the water depth becomes too deep to avoid submersion of the field investigator's face, then dive equipment must be utilized to set the chambers. Measurements of SOD may be conducted in water up to 50 feet deep or deeper if there is little current and adequate substrate for setting chambers. Typical depths are 15 to 30 feet deep. An appointed Environmental Protection Agency (EPA) divemaster will prepare a dive safety plan prior to the anticipated diving operation. All diving must be conducted in accordance with the US EPA's Diving Safety Manual.

Depending upon suspected or known contaminants in the water, adequate personal protection must be employed such as dry suits, dry hoods, full face masks or Superlight diving helmets.

Diver-to-diver and diver-to-surface communications should be employed if the divemaster on site deems it necessary.

In addition to contaminated water, other hazards exist that divers should be aware of and take appropriate safety precautions. These include, but are not limited to, biological hazards such as alligators, snakes, sharks and jellyfish. Other site hazards include strong currents, little or no visibility, hypothermia, heat stroke or heat exhaustion, and the possibility of entanglement with cables and lines.

Due to the size of chambers, the number of people required (typically 3 or 4), diving and other gear associated with collecting measurements, a large boat (typically 24 – 26 feet) is required. In large estuaries, wave heights of 2 feet are common and up to 4 feet are not uncommon. Therefore, an experienced operator capable of safely handling a vessel of this size in conditions that may be hazardous must be on board.

1.3.2 Procedural Precautions

The following precautions should be considered when conducting SOD measurements or when collecting NUTX water samples.

- When filling the water column respiration (blank) chamber(s), care must be taken to fill the chambers with the same bottom water that is in the contact chambers without entraining suspended sediment into the chambers.
- Care must be taken to ensure that there are no sticks, rocks or other obstructions beneath the sealing lips of the contact chambers that would allow the entrance of ambient water from outside the chambers.
- When conducting SOD measurements, a description of the observed sediment type or characteristics should be included in the field logbook.

2 Sediment Oxygen Demand Measurement

Ideally, four opaque cylindrical sediment contact chambers with open bottoms are deployed into the sediment and a DO probe is inserted into each chamber and the chamber is sealed off (Figure 1) (Murphy & Hicks, 1986). LSASD utilizes various size chambers that all have a volume (in liters) to surface area (m^2) ratio of approximately 240. The rate of decline of the DO within the chamber is then measured over a 1.5 to 2 hour period. Water column respiration may be measured utilizing one or two completely sealed “blank” chamber(s) (i.e. no sediment/water contact) filled with ambient bottom water, a DO probe is then inserted and the rate of DO decline is measured in these chamber(s). If measured, water column respiration rate is then subtracted from the rates in the sediment contact chamber(s).

The rate of oxygen demand is determined by utilizing a calibrated DO probe in each chamber. The DO probe can be on a logging multiparameter sonde or a standalone DO probe in accordance to LSASD Procedures for Measurement of Dissolved Oxygen (LSASDPROC-106). The sondes or DO probes are typically programmed to log a DO reading (in mg/L) every five minutes for approximately one to two hours. Logged data are backed approximately every 20 minutes. This not only insures against data loss, but also enables monitoring of any problems associated with the data collection such as a pump not running or a leaking seal on a chamber. DO measurements may also be obtained using non-logging DO

meters with data recorded manually or stored in an external logger.

Following is the procedure utilized for conducting field measurements of SOD using the previously described equipment.

- Calibrate DO and conductivity probes on the instruments, in accordance with LSASD Operating Procedure for *In-Situ* Water Quality Monitoring (LSASDPROC-111), (LSASDPROC-106) and LSASD Operating Procedure for Field Specific Conductance Measurement (LSASDPROC-101). Calibration of conductivity probes may not be required in fresh-water systems. However, DO measurements must be salinity corrected if working in an estuarine or saline environment therefore, conductivity must be calibrated for the sonde to determine salinity. If using a standalone DO probe/meter, the salinity should be entered manually. In soft substrates, it is useful to have turbidity measurements as well, in order to determine if sediments have been disturbed or suspended within the chambers. If turbidity is to be measured, follow LSASD Operating Procedure for Field Turbidity Measurement (LSASDPROC-103). Maintain a record of calibrations. If using an older style Clark Cell type DO probe, a stirring device is required in order to maintain appropriate water velocities across the membrane of the probe. Probes utilizing either the pulse technology or luminescent technology consume very little or no oxygen during measurements, therefore when using these types of DO probes, a stirrer is not required. A pump within the chamber is required in order to continually circulate water over the sediment within the chamber. The chamber pump maintains approximately a 0.1 feet/second velocity within the chamber.
- Measure vertical profiles of DO and temperature. Salinity should be measured in an estuarine environment to determine bottom salinities. If using a DO meter that does not also have a conductivity/salinity probe, the salinity measurement must be manually entered into the DO meter. Where near-bottom concentrations of DO are less than 2 milligrams per liter (mg/l), measurement of SOD rates must be done with care or the DO may be depleted within too short a period of time for effective assessment of SOD rates. If the bottom DO is less than 1 mg/l, it is possible to conduct a SOD by pumping oxygenated water into the chamber until the DO is stabilized at a high enough concentration to measure SOD.
- Check delivery of power and operation of the circulation pumps.
- Deploy chambers. Gently lower the chambers with a line from the boat. If the SOD is being conducted in a stream or river that is too shallow for boat operation, then the chambers must be carried in from shore. If carrying in from shore, place the downstream chambers first and work upstream so as not to disturb the sediment where the chambers will be placed. When measuring water column respiration, place the blank chamber(s) in such a manner as to not introduce suspended sediment into the blank chamber(s) during the purging process. Blank chamber(s) may be deployed, purged of entrained surface water and air, and then sealed prior to setting contact chambers to prevent introduction of sediment into the blank(s). When deploying chambers, deploy the blank chamber(s) first and purge with ambient bottom water. The bottom stoppers must be placed in the blank chamber(s) prior to lowering to the bottom in order to avoid entraining sediment into the chambers. Purging of the blank chamber(s) is accomplished by removing any trapped air, then plugging in one of the circulating hoses and turning on the circulating pump, leaving the other hose unattached. Deploy the remaining

contact chambers while purging the blank chamber(s) and filling with bottom water, again being careful not to disturb sediment which might be drawn into the blank chamber(s) during the purging process.

- Allow approximately 20 to 30 minutes for settlement of material that might have been suspended during deployment of the chambers and for the purging of the blank chamber(s). Install the DO monitoring probes and engage the circulation pumps. Terminate purging of the blank chamber(s) when the monitoring probes are installed by plugging in the remaining circulation hose. Caution should be used not to alter the contact chambers position on the sediment when servicing the chambers, especially in softer sediments. A purging period of 20 minutes allows the chamber contents to exchange the water volume approximately three times.
- Lower an ambient probe to chamber level; approximately one foot or less above the bottom. The ambient probe is typically placed on top of a blank chamber.
- Record initial monitoring data.
- If desired, dark bottles filled with ambient bottom water using a pump or VanDorn sampler, may be deployed alongside the blank chambers for incubation during the course of the SOD experiments. The water column respiration values obtained from the dark bottles may be used as a back up to blank chamber experiments in case of chamber failure. General procedures for conducting the light-dark bottle tests are provided in Standard Methods (APHA *et al.*, 1998).
- Record monitoring data every 5 minutes if logging measurements electronically or every 15 minutes if manually recording from a standard DO meter.
- Continue the experiment for approximately 2 hours or longer, if necessary, when using a non-logging DO meter. Oxygen readings at 15-minute intervals generally provide sufficient data points for determining the slope for linear regression analysis. If a logging DO meter or sonde recording at 5 minute intervals is utilized, 1.5 hours is generally sufficient.
- When sufficient data points have been recorded, remove monitoring probes from the chambers and retrieve equipment. Check meter calibrations and record in the logbook.

Figure 1: SOD Chamber

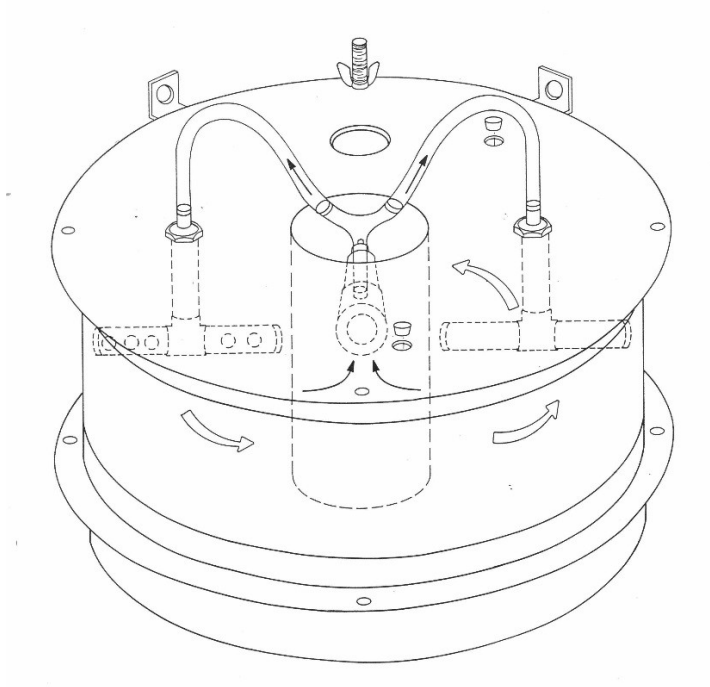

3 Nutrient Exchange (NUTX)

Water samples may also be collected from the SOD chambers in order to determine the rate of nutrient flux (or nutrient exchange) at the sediment water interface in accordance with LSASD'S Operating Procedure for Surface Water Sampling (LSASDPROC-201) and Field Sampling Quality Control (LSASDPROC-011).

Through isolation of a known volume of water over a known area of sediment, nutrient flux can be measured by periodic extraction of water samples from each chamber and analytically determining the change of concentration of selected nutrients over an extended incubation period. Sampling of water from the chamber may occur only at the beginning and end of the deployment period. Nutrient Flux assessments are usually conducted in conjunction with SOD measurement. Accordingly, the deployment and DO monitoring techniques are essentially the same, with minor modification of the DO monitoring due to the extended deployment times associated with nutrient flux assessments. In a similar fashion to SOD, nutrient samples should also be collected from the blank chamber(s) to account for water column changes in the NUTX calculation.

3.1 Nutrient Exchange Equipment

Following is a description of the supplies and techniques utilized for collecting nutrient samples from the SOD chambers:

- Narrow-mouth glass, 125 - 500 milliliter (ml) bottles: Number of bottles required is based upon the number of stations, number of chambers, and the sampling regime (i.e., initial plus final plus any intermediate samples) as defined in a Quality Assurance Project Plan and/or Sampling and Analysis Plan. The size of the container is dependent upon the minimum volume of water required by the laboratory for analysis. Glass bottles, as opposed to plastic or Nalgene®, are essential since the underwater sampling procedure depends upon a siphoning effect for the water sample to replace the air within the sampling container. Plastic bottle walls will compensate (collapse) for the water pressure and, thus, will not fill properly.
- Sample collection utilizes a siphon method for extracting a water sample from the chamber into the glass sample bottle: The siphoning device consists of a two-hole stopper sized properly to fit into the mouth of the glass sample bottle. The stopper is fitted with a stainless-steel tube in each hole. One tube serves as the inlet for siphoning the sample into the bottle. The inlet tube should extend into the bottle almost to the bottom. The second tube is shorter and serves as an outlet to allow the air to escape from the bottle during sampling. This outlet tube is cut flush with the bottom of the stopper to ensure that all air is purged from the sample bottle. Each tube should extend approximately one inch above the top of the stopper.
- Tygon® tubing (or other similar tubing that won't interfere with nutrient analysis), equipped with clamps, is attached to the outboard end of each tube. The sample intake (from the chamber to the bottle) Tygon® tubing attached to the long stainless inlet tube should be approximately 18 inches in length. A one-hole stopper, containing a piece of stainless tubing is connected to the distal end of the tubing. The stopper is sized appropriately to fit the sampling port in the chamber lid. The stainless tube that is inserted into the chamber should extend

approximately 6 inches into the chamber. The Tygon® tubing attached to the short piece of stainless tubing for air discharge from the sampling bottle needs to be approximately 6 inches in length to allow for the attachment of a clamp.

- Alternatively, samples may be pumped to the surface utilizing a peristaltic pump. If utilizing this method, the tubing must be purged of any entrained ambient surface water and care should be taken not to aerate the sample. The sample containers should be pre-preserved with the appropriate preservative. Nalgene® type sample containers may be utilized if the sample is being pumped to the surface.
- The suite of analytes for NUTX typically includes ammonia nitrogen, nitrate-nitrite nitrogen, total Kjeldahl nitrogen, total phosphorus, and total dissolved phosphorus. Nutrient samples are preserved with 10% sulfuric acid to a pH less than 2.

3.2 Nutrient Exchange Procedures

Deployment procedures for chambers used for (NUTX) measurements are the same as those outlined for SOD measurements. As stated previously, NUTX measurements can be initiated concurrently with SOD. However, incubation times (chamber deployment) are typically considerably longer for NUTX than for SOD, ranging from six to twenty-four hours. Measurement of nutrient flux rates can be conducted under aerobic or anaerobic conditions. However, the strategy for such measurements must be developed prior to initiation of field activities and include an assessment of available oxygen resources immediately prior to deployment of chambers. This approach is required since accomplishment of NUTX measurements should be initiated and completed without transitioning from aerobic to anaerobic conditions, or vice versa. Such a change in the status of oxygen resources of the water column entrapped within the chamber may yield inconsistent results not reflective of ambient conditions. Accordingly, chamber incubation times (the time period from collection of the initial sample to the final sample) should be estimated by using the observed SOD rate to determine approximately when the chamber may become anoxic. Precise sample collection times must be recorded as the sample times are used to calculate the flux rate. If the study design calls for crossing from aerobic to anoxic or anaerobic conditions, an intermediate sample should be collected at the approximate point that the chamber becomes anoxic. This is generally when the oxygen concentration in the chamber drops to approximately 0.25 mg/l. If collecting samples under anoxic or anaerobic conditions, the sampling bottles should be purged with an inert gas such as argon prior to sampling. Following is the sampling approach for collection of samples for determination of sediment nutrient flux rates.

Procedurally, water samples from each chamber are extracted as follows:

- Attach the siphoning device to a pre-cleaned sampling bottle and confirm that the tubing clamps are tight, and the stopper is secure in the bottle mouth.
- The sampler (diver/wader), inverts and submerges the bottle with siphon to chamber depth and attaches the siphon to the chamber by removing the solid (size 1) rubber stopper from the chamber lid and inserting the inlet tube stopper into the chamber lid. All tubing clamps remain closed. The bottle remains inverted in order to prevent the trapped air within the bottle from loosening the stopper and allowing ambient water to get into the bottle. If ambient water enters

the sample bottle, it must be taken back to the surface and either cleaned with D.I. water or replaced with a clean bottle before collecting the sample.

- With the attached bottle held next to the chamber and inverted, the clamp on the inlet tube is released.
- Due to the pressure differential between the sample bottle and chamber, water will be forced into the bottle from the chamber until the pressure equalizes. The deeper the chamber, the greater the pressure differential and more water will be forced into the bottle. Once water quits flowing into the bottle from the chamber, move the bottle to an upright position on top of the chamber and release the clamp on the short outlet tube. The bottle will still be positively buoyant so it must be held in place in order to prevent it from floating away. Care must be taken in order not to accidentally loosen or remove the inlet tube's stopper from the chamber lid. Because the air in the bottle is compressed due to the depth, it will begin flowing out of the outlet tube as soon as the clamp is released. As air flows out, water from the chamber will be siphoned into the bottle, eventually displacing all of the air.
- A second (size 1) stopper is positioned on the chamber lid across from the location where the inlet tube has been plugged into the chamber. This second stopper should be immediately removed when the siphoning begins to allow recruitment into the chamber of the sample volume removed during sampling. This is necessary because it is advisable to recruit from the water column rather than from sediment interstitial water.
- Observe or listen for air bubbles being purged from the sample bottle as it fills. When the bubbling ceases, the bottle is full. Secure clamps on both the exhaust and inlet port tubes, remove the siphon stopper from the chamber lid and replace the size 1 rubber stoppers back into the sampling and recruitment ports.
- Return the sample to the surface and process according to procedures appropriate for sample handling and preservation based upon the target analyses (LSASD LOQAM).
- A final sample at the end of the incubation period is required for NUTX rate determinations. The final sample is acquired in the same manner as the initial sample. Again, it is important to state that the DO concentration within the chamber must be monitored, and recorded, to make sure that if the experiment within the chamber was initiated under aerobic conditions, then it must be completed under aerobic conditions. The same requirement applies to experiments conducted under anaerobic (anoxic) conditions. As stated above, if incubating through the change from aerobic to anaerobic conditions an intermediate sample should be taken to serve as the end of the aerobic NUTX and the beginning of the anerobic conditions.
- After the final sample is collected from each chamber and the pump circulation checked, the study is finished, and the chambers can be retrieved. Ensure pump power has been disconnected prior to chamber retrieval.

Revision History

The top row of this table shows the most recent changes to this controlled document. For previous revision history information, archived versions of this document are maintained by the LSASD Document Control Coordinator on the LSASD local area network (LAN).

History	Effective Date
<p>Replace Chief with Supervisor; General formatting revisions.</p>	<p>April 22, 2023</p>
<p>LSASDPROC-507-R5, <i>Sediment Oxygen Demand</i>, replaces SESDPROC-507-R4.</p> <p>Changed SESD to LSASD and Science and Ecosystem Support Division to Laboratory Services and Applied Science Division throughout document.</p> <p>Changed the FQM from Hunter Johnson to Stacie Masters</p> <p>General: Added language to document to clarify statements and to make sections easier to follow. Corrected any typographical, grammatical, and/or editorial errors.</p> <p>Section 3.2: Added language to collect an intermediate sample if crossing from aerobic to anaerobic conditions and that bottles used for collecting anoxic or anaerobic samples should be purged with an inert gas such as argon prior to sampling.</p>	<p>June 11, 2020</p>
<p>LSASDPROC-507-R4, <i>Sediment Oxygen Demand</i>, replaces LSASDPROC-507-R3.</p> <p>General: Corrected any typographical, grammatical, and/or editorial errors.</p> <p>Cover Page: Changed the Ecological Assessment Branch Supervisor to the Field Services Branch Supervisor. Changed the FQM from Bobby Lewis to Hunter Johnson.</p> <p>Section 2: Added to the first paragraph – “LSASD utilizes various size chambers that all have a volume (L) to surface area (m²) ratio of approximately 240.” “Water column respiration may be measured utilizing one or two completely sealed “blank” chamber(s) (i.e. no sediment/water contact) filled with ambient bottom water, a DO probe is then inserted and the rate of DO decline is measured in these chamber(s).”</p> <p>Second paragraph – updated to allow the use of DO probes and non- logging DO meters</p> <p>Bullet A: Added – “If using a standalone DO probe/meter, the salinity should be entered manually.”</p>	<p>July 22, 2015</p>

<p>Bullet B: Added – “If the bottom DO is less than 1 mg/l, it is possible to conduct a SOD by pumping oxygenated water into the chamber until the DO is stabilized at a high enough concentration to measure SOD.”</p> <p>Bullet D: Reworded and added – “If measuring water column respiration, place the blank chamber(s) in such a manner as to not introduce suspended sediment into the blank chamber(s) during the purging process. Blank chamber(s) may be deployed, purged, and then sealed prior to setting contact chambers to prevent introduction of sediment into the blank.”</p> <p>Bullet F: Added – “or less”</p> <p>Section 3.1: First Bullet – Changed “500 milliliter” to “125 – 500 milliliters”</p> <p>Third Bullet: Added – “Alternatively, samples may be pumped to the surface utilizing a peristaltic pump. If utilizing this method, the tubing must be purged of any entrained ambient surface water and care should be taken not to aerate the sample. The sample containers should be pre- preserved. Nalgene® type sample containers may be utilized if the sample is being pumped to the surface.”</p> <p>Forth Bullet: Changed “10%” to “10% or greater”</p> <p>Section 3.2: First paragraph, third sentence – reworded – “However, incubation times (chamber deployment) are typically considerably longer for NUTX than for SOD, ranging from four to twenty-four hours.”</p>	
<p>LSASDPROC-507-R3, <i>Sediment Oxygen Demand</i>, replaces LSASDPROC-507-R2.</p>	<p>September 12, 2013</p>
<p>LSASDPROC-507-R2, <i>Sediment Oxygen Demand</i>, replaces LSASDPROC-507-R1.</p>	<p>December 7, 2009</p>
<p>LSASDPROC-507-R1, <i>Sediment Oxygen Demand</i>, replaces LSASDPROC-507-R0.</p>	<p>November 1, 2007</p>
<p>LSASDPROC-507-R0, <i>Sediment Oxygen Demand</i>, Original Issue</p>	<p>February 05, 2007</p>

References

American Public Health Association (APHA), American Waterworks Association (AWWA), and the Water Environment Federation (WEF). 1998. Standard Methods for the Examination of Water and Wastewater, 20th Edition. Washington, D.C.

Murphy, Philip J. and Delbert B. Hicks. 1986. In-Situ Method for Measuring Sediment Oxygen Demand. U.S. Environmental Protection Agency, Athens, GA. pp. 307-322. *In* Kathryn J. Hatcher (ed.). Sediment Oxygen Demand, Processes, Modeling and Measurement. University of Georgia Institute of Natural Resources, Athens, GA.

LSASDPROC-1002, LSASD Operating Procedure for Logbooks, Most Recent Version.

LSASDPROC-011, LSASD Operating Procedure for Field Sampling Quality Control, Most Recent Version.

LSASDPROC-101, LSASD Operating Procedure for Field Specific Conductance Measurement, Most Recent Version.

LSASDPROC-103, LSASD Operating Procedures for Field Turbidity Measurement, Most Recent Version.

LSASDPROC-106, LSASD Operating Procedure for Measurement of Dissolved Oxygen, Most Recent Version.

LSASDPROC-111, LSASD Operating Procedure for *In Situ* Water Quality Monitoring, Most Recent Version.

LSASDPROC-201, LSASD Operating Procedure for Surface Water Sampling, Most Recent Version

USEPA Diving Safety Manual, Most Recent Version US Environmental Protection Agency, Washington, DC.

LSASD LOQAM. Laboratory Services Branch, Laboratory Operations and Quality Assurance Manual. Most Recent Version. Region 4, Laboratory Services and Applied Science Division, Athens, GA.