

United States  
Environmental Protection  
Agency

Office of Air Quality  
Planning and Standards  
Research Triangle Park, NC 27711

EPA-454/R-00-022  
April 2000

---

Air

---



# **HOT MIX ASPHALT PLANTS KILN DRYER STACK INSTRUMENTAL METHODS TESTING**

## **ASPHALT PLANT "B" CARY, NORTH CAROLINA**





**HOT MIX ASPHALT PLANTS  
KILN DRYER STACK  
INSTRUMENTAL METHODS TESTING**

Asphalt Plant "B"  
Cary, North Carolina

Prepared for

Office of Air Quality Planning and Standards  
Emissions, Monitoring and Analysis Division  
Emission Measurement Center (MD-19)  
Research Triangle Park, North Carolina 27711  
Mr. Michael L. Toney  
Work Assignment Manager

EPA Contract No. 68-D-98-027  
Work Assignment 3-02  
MRI Project No. 104952-1-002-05

April 2000





## PREFACE

This test report was prepared by Midwest Research Institute (MRI) for the U. S. Environmental Protection Agency (EPA) under EPA Contract No. 68-D-98-027, Work Assignment No. 3-02. A revised draft report was submitted under Work Assignment 2-10. Mr. Michael Toney is the EPA Work Assignment Manager (WAM). Mr. Scott Klamm is the MRI Work Assignment Leader (WAL). The field test was performed under EPA Contract No. 68-D2-0165, Work Assignment No. 4-24. A draft report was submitted under EPA Contract No. 68-W6-0048, Work Assignment No. 2-08, task 2. Mr. Michael Toney was also the WAM for the previous work assignments. Dr. Thomas Geyer was the MRI WAL for Work Assignments No. 4-24 and 2-10 and the Task Leader for Task 2. Mr. John Hosenfeld was the MRI WAL for Work Assignment No. 2-08.

This report consists of one volume (351 pages) with six sections and five appendices.

MIDWEST RESEARCH INSTITUTE

  
for John Hosenfeld  
Program Manager

Approved:



Jeff Shular  
Director, Environmental Engineering Department

April 2000



## TABLE OF CONTENTS

	<u>Page</u>
1.0 INTRODUCTION .....	1-1
1.1 BACKGROUND .....	1-1
1.2 PROJECT SUMMARY .....	1-1
1.3 PROJECT PERSONNEL .....	1-7
2.0 PROCESS DESCRIPTION AND TEST LOCATIONS .....	2-1
2.1 PROCESS DESCRIPTION .....	2-1
2.2 TEST LOCATIONS .....	2-1
2.2.1 Baghouse Inlet Duct .....	2-1
2.2.2 Baghouse Outlet (Stack) .....	2-1
2.3 VOLUMETRIC FLOW .....	2-1
3.0 RESULTS .....	3-1
3.1 TEST SCHEDULE .....	3-1
3.2 FIELD TEST PROBLEMS AND CHANGES .....	3-4
3.3 METHOD 25A RESULTS .....	3-4
3.4 FTIR RESULTS .....	3-5
3.5 ANALYTE SPIKE RESULTS .....	3-6
4.0 TEST PROCEDURES .....	4-1
4.1 SAMPLING SYSTEM DESCRIPTION .....	4-1
4.1.1 Sample System Components .....	4-1
4.1.2 Sample Gas Stream Flow .....	4-3
4.2 FTIR SAMPLING PROCEDURES .....	4-3
4.2.1 Batch Samples .....	4-4
4.2.2 Continuous Sampling .....	4-4
4.3 ANALYTE SPIKING .....	4-5
4.3.1 Analyte Spiking Procedures .....	4-5
4.3.2 Analysis of Spiked Results .....	4-7
4.4 ANALYTICAL PROCEDURES .....	4-7
4.4.1 Computer Program Input .....	4-8
4.4.2 EPA Reference Spectra .....	4-9
4.5 FTIR SYSTEM .....	4-12
4.6 CONTINUOUS EMISSIONS MONITORING FOR TOTAL HYDROCARBONS (THC) .....	4-12
4.6.1 Total Hydrocarbon Sampling Procedures .....	4-13
4.6.2 Hydrocarbon Emission Calculations .....	4-13

## TABLE OF CONTENTS (CONTINUED)

	<u>Page</u>
5.0 SUMMARY OF QA/QC PROCEDURES .....	5-1
5.1 SAMPLING AND TEST CONDITIONS .....	5-1
5.2 FTIR SPECTRA .....	5-2
5.3 METHOD 25A .....	5-3
5.3.1 Initial Checks .....	5-3
5.3.2 Daily Checks .....	5-3
6.0 REFERENCES .....	6-1
APPENDIX A - METHOD 25A AND VOLUMETRIC FLOW DATA .....	A-1
A-1 METHOD 25A RESULTS .....	A-2
A-2 METHOD 25A CALIBRATION AND QA CHECK DATA .....	A-3
A-3 VOLUMETRIC FLOW DATA .....	A-4
APPENDIX B - FTIR DATA .....	B-1
B-1 FTIR RESULTS .....	B-2
B-2 FTIR FIELD DATA RECORDS .....	B-3
B-3 FTIR FLOW AND TEMPERATURE READINGS .....	B-4
APPENDIX C - EQUIPMENT CALIBRATION CERTIFICATES .....	C-1
C-1 CALIBRATION GAS CERTIFICATES .....	C-2
C-2 ENVIRONICS MASS FLOW METER CALIBRATIONS .....	C-3
APPENDIX D - TEST METHODS .....	D-1
D-1 EPA METHOD 320 .....	D-2
D-2 EPA FTIR PROTOCOL .....	D-3
D-3 EPA METHOD 25A .....	D-4
D-4 EPA DRAFT METHOD 205 .....	D-5
APPENDIX E - PROCESS DATA .....	E-1

## LIST OF FIGURES

Figure 2-1. Baghouse inlet. ....	2-2
Figure 2-2. Baghouse outlet (stack) .....	2-3
Figure 4-1. Sampling system schematic. ....	4-2

TABLE OF CONTENTS (CONTINUED)

Page

LIST OF TABLES

TABLE 1-1.	SUMMARY OF FTIR RESULTS FOR WET SAMPLES AT PLANT B . . . .	1-4
TABLE 1-2.	SUMMARY OF FTIR RESULTS FOR CONDENSER SAMPLES AT PLANT B . . . . .	1-5
TABLE 1-3.	SUMMARY OF HYDROCARBON EMISSIONS RESULTS . . . . .	1-6
TABLE 1-4.	PROJECT PERSONNEL . . . . .	1-7
TABLE 2-1.	SOURCE GAS COMPOSITION AND FLOW SUMMARY . . . . .	2-5
TABLE 3-1.	PLANT B FTIR AND 25A TEST SCHEDULE . . . . .	3-2
TABLE 3-2.	MINIMUM AND MAXIMUM THC CONCENTRATIONS . . . . .	3-5
TABLE 3-3.	SPIKE RESULTS IN WET SAMPLES COLLECTED AT THE BAGHOUSE INLET . . . . .	3-8
TABLE 3-4.	SPIKE RESULTS IN WET SAMPLES AT THE BAGHOUSE OUTLET . . .	3-8
TABLE 3-5.	COMPARISON OF EPA REFERENCE SPECTRA TO SPECTRUM OF TOLUENE CYLINDER STANDARD . . . . .	3-10
TABLE 4-1.	PROGRAM INPUT FOR ANALYSIS OF SAMPLE SPECTRA . . . . .	4-10
TABLE 4-2.	PROGRAM INPUT FOR ANALYSIS, CTS SPECTRA, AND PATH LENGTH DETERMINATION . . . . .	4-11
TABLE 4-3.	RESULTS OF PATH LENGTH DETERMINATION . . . . .	4-11
TABLE B-1.	FTIR RESULTS OF WET SAMPLES FROM THE BAGHOUSE OUTLET AT PLANT "B" . . . . .	B-5
TABLE B-2.	FTIR RESULTS OF WET SAMPLES FROM THE BAGHOUSE OUTLET AT PLANT "B" . . . . .	B-13
TABLE B-3.	FTIR RESULTS OF DRY SAMPLES FROM THE BAGHOUSE OUTLET AT PLANT "B" . . . . .	B-22
TABLE B-4.	FTIR RESULTS OF DRY SAMPLES FROM THE BAGHOUSE OUTLET AT PLANT "B" . . . . .	B-29



## 1.0 INTRODUCTION

### 1.1 BACKGROUND

The Emission Measurement Center (EMC) issued work assignment 4-24 to Midwest Research Institute (MRI) to conduct emissions testing at asphalt concrete production plants. This was in response to a test request from the Minerals and Inorganic Chemicals Group of the Emission Standards Division (ESD) and Source Characterization Group of the Emission Monitoring and Analysis Division (EMAD), both in the Office of Air Quality Planning and Standards (OAQPS), U. S. EPA. The test program was performed in August 1997 under work assignment 4-24, on EPA Contract No. 68-D2-0165. A draft report was prepared under work assignment, 2-08, under EPA Contract No. 68-W6-0048. A revised report was prepared under work assignment 2-10, EPA Contract No. 68-D-98-027. The process description and data in Appendix E was prepared by ECR Incorporated and was included in this report without MRI review.

The purpose of this project was to perform an emissions test on the inlet and outlet of a baghouse that controls emissions from the parallel-flow rotary dryer process used at the Asphalt Plant B facility in Cary, North Carolina. MRI used EPA Fourier transform infrared (FTIR) Method 320<sup>1</sup> and EPA Method 25A. Method 320 is an extractive test method using FTIR spectroscopy. Method 320 uses quantitative analytical procedures described in the EPA FTIR Protocol<sup>2</sup>. Method 25A is a an extractive test method using a Flame Ionization Analyzer (FIA). The results were used to characterize and quantify hazardous air pollutant (HAP) emissions and the performance of the control unit for maximum achievable control technology (MACT) standard development for this industry.

### 1.2 PROJECT SUMMARY

Asphalt paving materials are produced by drying and mixing various amounts of raw (and sometimes recycled) materials with asphalt cement in a rotary drum dryer. The product is then conveyed to heated storage silos before loading into trucks for distribution. The dryer emissions are drawn through a knockout box, for primary particulate control, and then a baghouse before being emitted to the atmosphere. Testing was conducted at the inlet and outlet of the baghouse to determine the measurable emissions released.

Three test runs were conducted by MRI at each location over a 3-day period concurrently with manual method testing conducted by Pacific Environmental Services, Inc. (PES). Test Runs 1 and 2 were conducted during production using reclaimed asphalt pavement (RAP). Run 3 was conducted during production using non-RAP containing material.

The FTIR samples were collected by alternately sampling the baghouse inlet and stack using a single instrument, and the Method 25A testing was continuous at both locations using two analyzers. A summary of the FTIR results for samples collected on a hot/wet basis (i.e., extracted stack gas direct to the instrument) is presented in Table 1-1. FTIR results for samples collected on a cold/dry basis (i.e., stack gas passed through a condenser to remove moisture) are summarized in Table 1-2. The Method 25A results are summarized in Table 1-3. The complete Method 25A results are in Appendix A, and the complete FTIR results are in Appendix B.

Method 320 uses an extractive sampling procedure. A probe, pump, and heated line are used to transport sample gas from the test port to a gas distribution manifold in a trailer that contains the FTIR equipment. Infrared spectra of a series of samples were recorded, and quantitative analysis of the spectra was done after the FTIR data collection was completed. All spectral data and results were saved on computer media. A compact disk containing all FTIR data is provided with this report.

Method 25A also uses an extractive sampling procedure, and the same sample transport system was used for both the FTIR and Method 25A testing. Volume concentration data and results obtained from the samples were recorded and saved on computer media and reviewed after the test was completed.

The FTIR spectra show evidence of aliphatic hydrocarbon compounds in the emissions. Hexane and 2,2,4-trimethylpentane (isooctane) are the only HAP spectra in the EPA library that meet this description. Therefore, in the draft analysis results, the hydrocarbon emissions were principally represented by "hexane." Since then, MRI has measured reference spectra of some additional non-HAP hydrocarbon compounds. These new hydrocarbon reference spectra were used in revised analyses of the sample spectra. In the revised results, the hydrocarbon mixture is principally represented by n-heptane with contributions from 1-pentene and 2-methyl-2-butene.

The "wet" results are from spectra of untreated samples. The "condenser" results are from spectra of sample gas that was passed through an ice-temperature chiller to remove



moisture from the sample. The condenser results are reported on a dry basis. The condenser, by reducing moisture interference, can aid the analyses of some compounds, but soluble species such as formaldehyde are more accurately measured in the wet samples. Even the concentration of non-soluble species can be reduced by the condenser because vapor pressures are lower at the condenser temperature. Note that the condenser and wet samples cannot be compared directly because they were measured at different times (see Table 3-1).

TABLE 1-1. SUMMARY OF FTIR RESULTS FOR WET SAMPLES AT PLANT B<sup>a</sup>

Untreated (wet) Samples		Run 1		Run 2		Run 3	
		Inlet	Outlet	Inlet	Outlet	Inlet	Outlet
Toluene	ppm			6.9	0.6	6.6	7.5
	lb/hr			3.2	0.3	3.18	3.9
	kg/hr			0.68	0.06	0.69	0.90
Hexane	ppm						
	lb/hr						
	kg/hr						
Ethylene	ppm	12.6	10.70	8.01	7.6	13.3	13.9
	lb/hr	1.811	1.653	1.131	1.159	1.944	2.173
	kg/hr	0.118	0.12	0.072	0.080	0.129	0.154
Methane	ppm	11.2	11.40	10.2	9.6	10.5	10.8
	lb/hr	0.917	1.00	0.824	0.833	0.875	0.962
	kg/hr	0.034	0.04	0.030	0.033	0.033	0.039
Sulfur Dioxide	ppm	10.9	6.50	14.4	15.7	16.0	17.7
	lb/hr	3.6	2.29	4.64	5.4	5.3	6.3
	kg/hr	0.53	0.36	0.68	0.85	0.81	1.02
Carbon Monoxide	ppm	125.1	125.60	18.4	56.1	163.5	194.7
	lb/hr	18.0	19.30	2.6	8.48	23.9	30.3
	kg/hr	1.17	1.34	0.17	0.58	1.59	2.14
Formaldehyde	ppm	2.19	1.00			5.3	4.46
	lb/hr	0.337	0.16			0.84	0.75
	kg/hr	0.0236	0.01			0.059	0.057
Heptane	ppm	7.75	8.10	10.7	6.8	6.7	4.41
	lb/hr	3.987	4.46	5.381	3.672	3.49	2.46
	kg/hr	0.9296	1.11	1.2312	0.9011	0.827	0.621
1-Pentene	ppm	4.34	6.90		4.8	0.7	2.89
	lb/hr	1.562	2.65		1.804	0.26	1.13
	kg/hr	0.2550	0.46		0.3099	0.043	0.199
2-Methyl-2-butene	ppm					0.2	
	lb/hr					0.07	
	kg/hr					0.012	

<sup>a</sup> The two locations were sampled sequentially. Sampling times for each condition are shown in Table 3-1 and in Tables B-1 to B-4. Blank spaces indicate a "non-detect."

TABLE 1-2. SUMMARY OF FTIR RESULTS FOR CONDENSER SAMPLES AT PLANT B<sup>a</sup>

Condenser Samples		Run 1		Run 2		Run 3	
		Inlet	Outlet	Inlet	Outlet	Inlet	Outlet
Toluene	ppm lb/hr kg/hr	ND <sup>b</sup>	ND	ND	ND	ND	ND
Hexane	ppm lb/hr kg/hr	ND	ND	ND	ND	ND	ND
Ethylene	ppm lb/hr kg/hr	1.74 0.18 0.008	ND	1.77 0.18 0.008	2.26 0.25 0.012	ND	ND
Methane	ppm lb/hr kg/hr	1.9 0.11 0.0029	2.0 0.12 0.0034	2.4 0.14 0.0037	2.6 0.16 0.0045	2.0 0.14 0.0043	2.1 0.15 0.0047
Sulfur Dioxide	ppm lb/hr kg/hr	18.8 4.36 0.46	18.2 4.51 0.51	26.3 6.13 0.65	23.8 5.93 0.67	10.7 2.9 0.36	7.1 2.0 0.26
Carbon Monoxide	ppm lb/hr kg/hr	62.3 6.3 0.29	42.5 4.6 0.23	57.7 5.9 0.27	98.7 10.7 0.53	40.4 4.81 0.26	48.1 5.99 0.34
Formaldehyde	ppm lb/hr kg/hr	ND	ND	ND	ND	3.9 0.50 0.029	ND
3-Methylpentane	ppm lb/hr kg/hr	ND	ND	ND	ND	1.0 0.38 0.063	1.78 0.68 0.118
Isooctane	ppm lb/hr kg/hr	ND	ND	0.3 0.136 0.0256	ND	ND	ND
Heptane	ppm lb/hr kg/hr	8.20 2.986 0.4930	7.5 2.914 0.5125	8.1 2.968 0.4923	7.7 3.018 0.5332	ND	2.03 0.90 0.182
1-Pentene	ppm lb/hr kg/hr	ND	ND	0.2 0.055 0.0064	ND	ND	0.12 0.04 0.005
2-Methyl-2-butene	ppm lb/hr kg/hr	ND	ND	ND	ND	0.1 0.02 0.003	ND
n-Pentane	ppm lb/hr kg/hr	ND	ND	ND	ND	4.5 1.37 0.190	ND

<sup>a</sup> The two locations were sampled sequentially (not simultaneously) with the FTIR instrument. Hot/wet and dry samples were also measured sequentially. Sampling times are shown in Tables B-1 through B-4, and in the accompanying graphs in Appendix B.

<sup>b</sup> ND = not detected in this run.

TABLE 1-3. SUMMARY OF HYDROCARBON EMISSIONS RESULTS

<b>Test Data<sup>a</sup></b>				
Run Number	1	2	Average <sup>c</sup>	3
Date	27-Aug-98	28-Aug-98		29-Aug-98
<b>Baghouse Inlet</b>				
<b>Gaseous Concentrations</b>				
THC Concentration (ppm propane)	85.8	61.9	73.6	46.1
THC <sup>b</sup> Concentration, ppmc (wet basis)	257.4	184.1	220.7	138.2
THC Concentration, ppmc (dry basis)	363.5	253.9	308.7	170.1
<b>Emissions Data</b>				
THC Emission Rate, lb/hr <sup>d</sup>	15.9	11.1	13.5	8.7
THC Emission Rate, kg/hr	7.2	5.0	6.1	3.9
<b>Baghouse Outlet ( Stack)</b>				
<b>Gaseous Concentrations</b>				
THC Concentration (ppm propane)	38.3	43.6	40.9	35.7
THC Concentration, ppmc (wet basis)	114.9	130.7	122.8	107.2
THC Concentration, ppmc (dry basis)	162.6	181.5	172.1	134.3
<b>Emissions Data</b>				
THC Emission Rate, lb/hr	7.6	8.5	8.0	7.2
THC Emission Rate, kg/hr	3.4	3.8	3.6	3.2

<sup>a</sup> Method 25A results and run averages are presented in Appendix A-1. Run Times are in Table 3-1.

<sup>b</sup> THC = Total hydrocarbons.

<sup>c</sup> The results of the first 2 runs were averaged because the process was using reclaimed asphalt pavement (RAP). During Run 3 the process was using non-RAP material.

<sup>d</sup> See equations 5 & 6 in Section 4.6.2 for emission rate calculations.

### 1.3 PROJECT PERSONNEL

The EPA test program was administered by the EMC. The Test Request was initiated by the Minerals and Inorganic Chemicals Group of the ESD. Some key project personnel are listed in Table 1-4.

TABLE 1-4. PROJECT PERSONNEL

Organization and Title	Name	Phone Number
Plant B Services, Manager	Gene Mills	(704) 394-8354
Plant B Manager/Supervisor	Don Schell	(919) 851-1376
U. S. EPA, EMC Work Assignment Manager Work Assignment 4-24 Work Assignment 2-08	Michael L. Toney	(919) 541-5247
U. S. EPA Minerals & Inorganic Chemicals Group	Mary Johnson	(919) 541-5247
MRI Work Assignment Leader Work Assignment 3-02	Scott Klamm	(818) 753-7600 Ext. 1228
MRI Work Assignment Leader Work Assignment 4-24 Work Assignment 2-10 Task Leader, Work Assignment 2-08, Task 2	Thomas J. Geyer	(919) 851-8181 Ext 3120
MRI Program Manager Work Assignment Leader Work Assignment 2-08	John Hosenfeld	(816) 753-7600 Ext 1336



## 2.0 PROCESS DESCRIPTION AND TEST LOCATIONS

### 2.1 PROCESS DESCRIPTION

A process description and process data were provided by EC/R Incorporated. The EC/R description and data are attached to this report in Appendix E.

### 2.2 TEST LOCATIONS

Figures 2-1 and 2-2 are drawings of the baghouse inlet and outlet test locations. Samples from both the baghouse outlet stack and the baghouse inlet were analyzed from the same trailer position.

#### 2.2.1 Baghouse Inlet Duct

The inlet location was a circular duct with a diameter of 54½ inches (in.). Testing was conducted in the vertical segment of the duct downstream of the manual method ports. FTIR and Method 25A testing was conducted in a 4-in. diameter test port that was installed upstream of the manual test ports.

#### 2.2.2 Baghouse Outlet (Stack)

The outlet location was a rectangular stack 49¾ in. wide and 33 in. deep. Six ports, used for the manual sampling, were arranged horizontally in a line about 24 in. upstream of the stack exit. Another 4-in. port was installed 3 feet upstream of the manual sampling ports and was used for the FTIR and Method 25A sampling.

### 2.3 VOLUMETRIC FLOW

Table 2-1 summarizes the gas composition and exhaust gas flow data provided by PES. PES provided volumetric flow rates, moisture content, gas molecular weight, etc. as part of their manual testing; therefore, MRI did not conduct these tests.

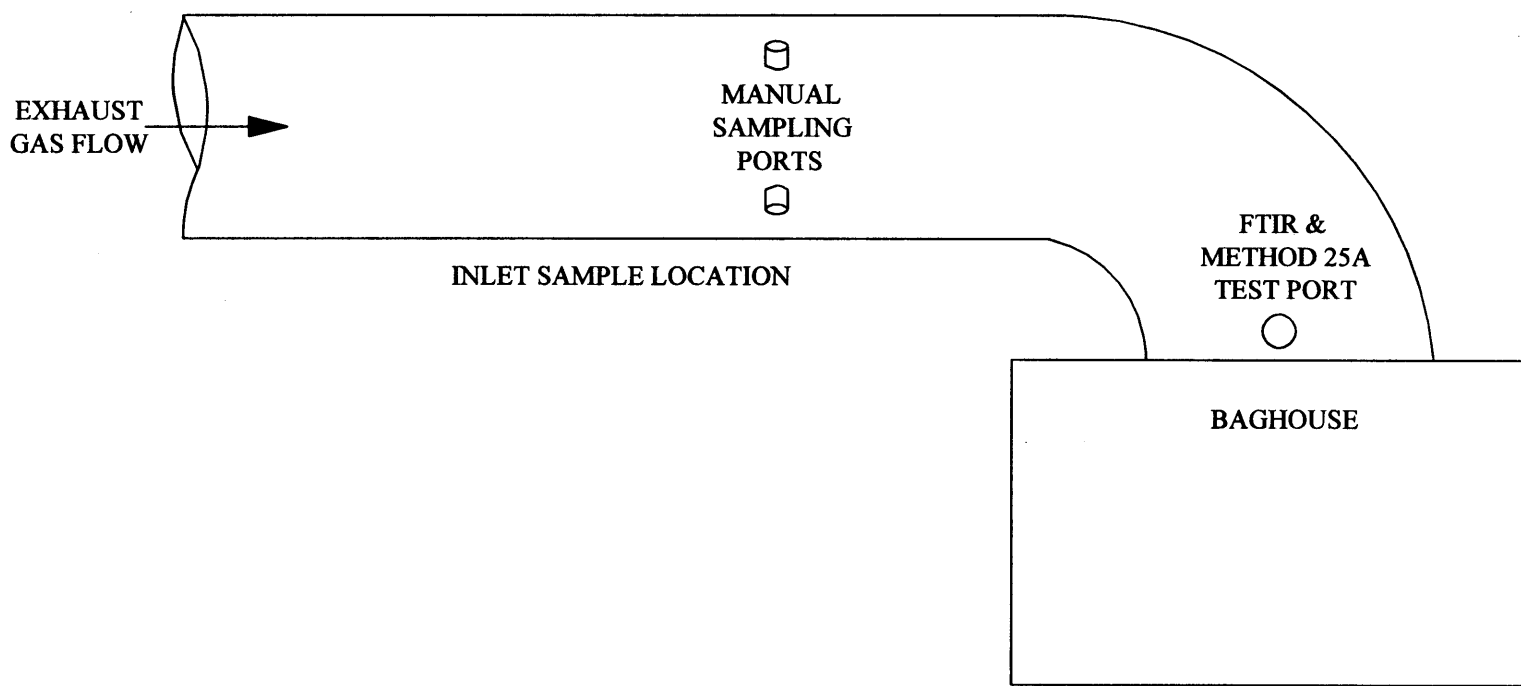
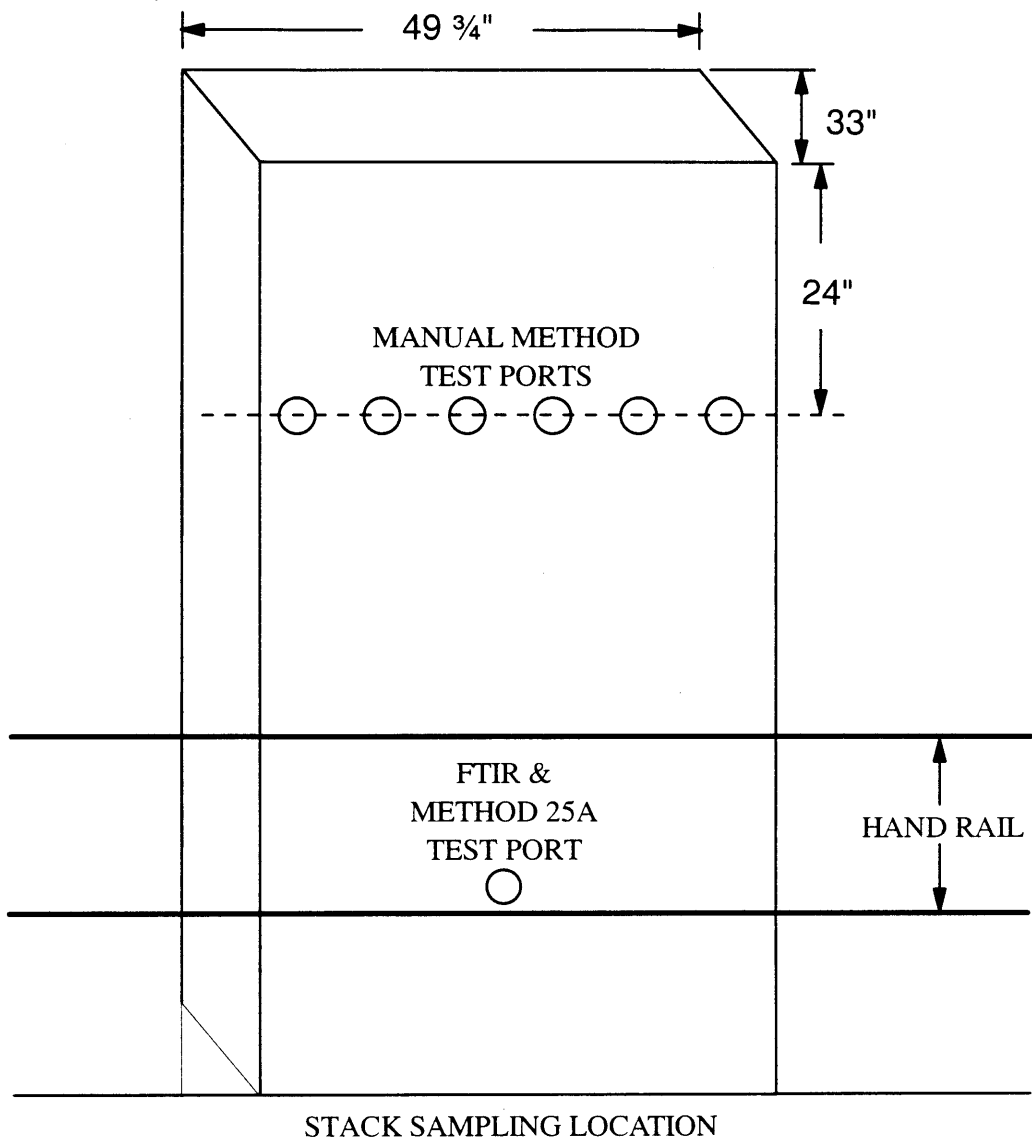

Figure 2-1. Baghouse inlet.





DRAWING NOT TO SCALE

Figure 2-2. Baghouse outlet (stack).



TABLE 2-1. SOURCE GAS COMPOSITION AND FLOW SUMMARY

<b>Test Data<sup>a</sup></b>			
Run Number	1	2	3
Date	27-Aug-98	28-Aug-98	29-Aug-98
<b>Baghouse Inlet</b>			
Oxygen, %	14.0	13.1	15.2
Carbon Dioxide, %	4.9	5.2	4.0
Moisture Content, %	29.2	27.5	18.8
Gas Stream Velocity, fps <sup>b</sup>	49.6	49.1	49.8
Volumetric Flow Rate, dscfm <sup>c</sup>	23,334	23,446	27,252
<b>Baghouse Outlet ( Stack)</b>			
Oxygen, %	15.0	13.6	16.3
Carbon Dioxide, %	4.0	4.9	3.0
Moisture Content, %	29.4	28.0	20.2
Gas Stream Velocity, fps	74.3	74.1	74.5
Volumetric Flow Rate, dscfm	24,868	24,978	28,526

<sup>a</sup> Raw gas composition and velocity data are in Appendix A-3. The values reported are averages of the values reported from Methods 23 and 29. The raw data in Appendix A-3 was provided by Pacific Environmental Services (PES).

<sup>b</sup> fps = feet per second.

<sup>c</sup> dscfm = dry standard cubic feet per minute.

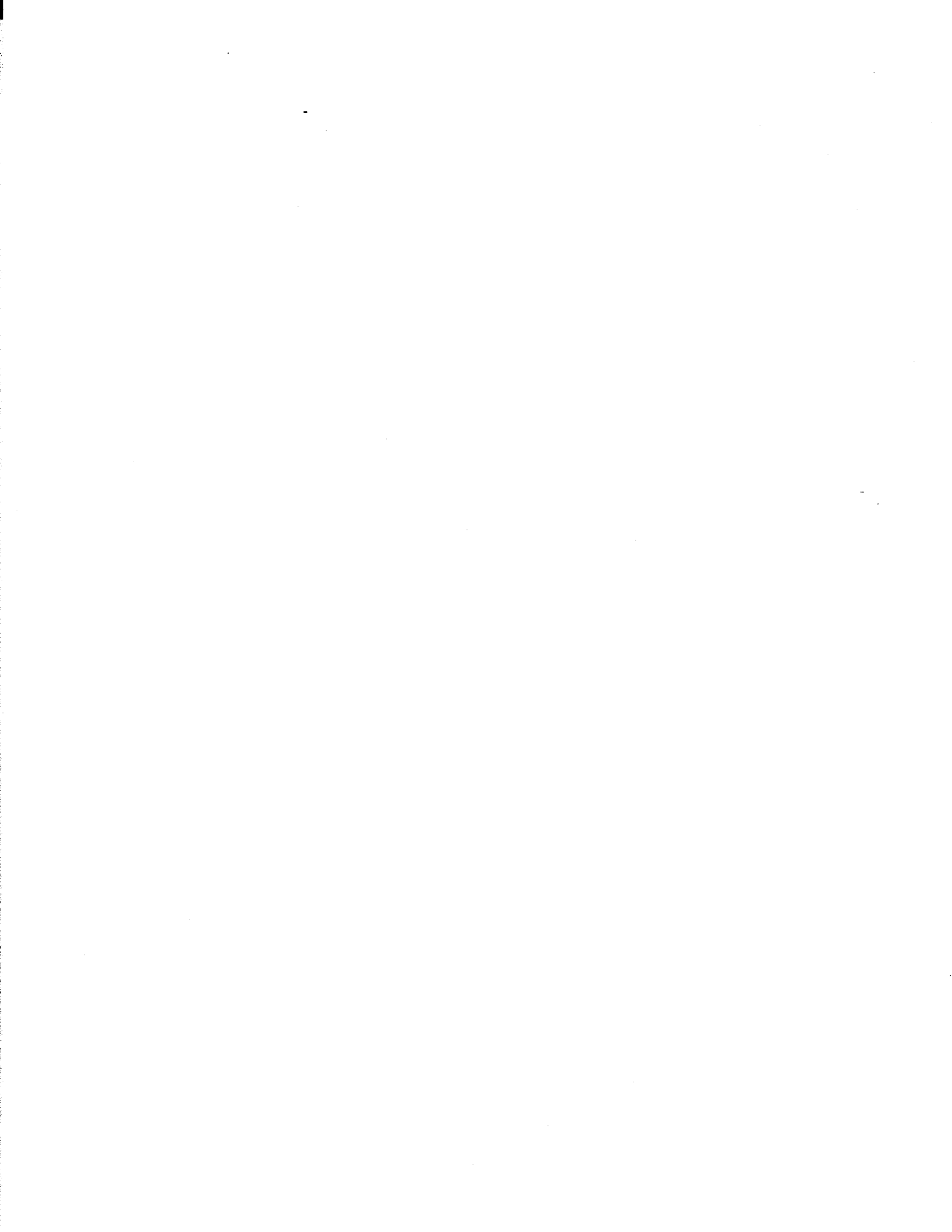

### 3.0 RESULTS

#### 3.1 TEST SCHEDULE

The test program at Asphalt Plant B was completed from August 27 to August 29, 1997. Table 3-1 summarizes the sampling schedule. A complete record of all Method 25A and FTIR sampling is in Appendices A and B. The FTIR and Method 25A sampling was coordinated with, and in the same periods as the manual sampling conducted by PES, but was not exactly simultaneous.

TABLE 3-1. PLANT B FTIR AND 25A TEST SCHEDULE

Date	FTIR				THC (25A) Inlet and Outlet	Plant Down Times*
	INLET		OUTLET			
	Wet	Dry	Wet	Dry		
8/27/97	932-1002				940-1516	
						1002-1007
			1020-1045 (spike)			
	1104-1127 (spike)					1140-1146
			1148-1213			
	1220-1247					
				1258-1323		
		1333- 1400				
				1427-1443		1402-1412
		1448-1518				
8/28/97			732-805 (spike)		744-1431	
	818-841 (spike)					901-909
	923-945					
			954-1027			
		1042-1109				
						1110-1128
				1129-1153		
		1202-1232				
				1241-1310		
	1318-1345					
				1353-1354		
						1355-1407
			1409-1430			

3-2

TABLE 3-1. (CONTINUED)

Date	FTIR				THC (25A) Inlet and Outlet	Plant Down Times <sup>a</sup>
	INLET		OUTLET			
	Wet	Dry	Wet	Dry		
8/29/97	759-840 (spike)				816-1412	
			848-921 (spike)			
	927-959					
			1005-1045			
	1056-1120					
				1130-1200		
		1207-1210, 1223-1239 <sup>b</sup>				1212-1221
						1242-1323
			1329-1359			
	1407-1414					

33

<sup>a</sup> From EC/R Report in Appendix E.

<sup>b</sup> The FTIR outlet valve was closed so this represents a single static sample.

### 3.2 FIELD TEST PROBLEMS AND CHANGES

Typically, a glass wool plug is inserted at the inlet of the sample probe as a pre-filter. The particulate at the baghouse inlet was high enough to quickly clog the pre-filter. Therefore, an additional Balston filter was installed at the probe inlet. With this arrangement it was possible to sample for extended periods at the inlet location.

The outlet valve of the FTIR cell was closed for a period during Run 3 so that the inlet sample was not flowing through the cell (spectra 18290075 to 18290093). For part of this period the process was not operating, but these are, in effect, spectra of a single sample.

During the Run 2 post-run vacuum leak check a leak was observed in the inlet sampling system. It is not known what if any leak was present at the sampling pressure. The leak probably occurred about 4 hours into the run when the inlet Balston filter was replaced during process down time. The Method 25A passed the post-run calibration so this may have had little effect on the results.

Some samples were passed through a moisture condenser before measurement with the FTIR system. This was not mentioned in the Site Specific Test Plan (SSTP), but it was a useful procedure for FTIR analysis because the sample gas contained a relatively high moisture content (about 30 percent by volume). The use of the condenser was approved by the EPA observer at the test site. The condenser was used for portions of all three test runs. Moisture removal was accomplished by passing the sample gas through an impinger immersed in an ice bath just before the FTIR cell. Moisture removal reduces spectral interference in some frequency regions and can improve the analysis of compounds that can pass through the condenser. Analyte spiking was successfully performed through the condenser. Uncertainty results in Section 3.6 show that the quantitation limits are lower for compounds that can pass through a condenser.

### 3.3 METHOD 25A RESULTS

Table 3-1 summarizes the Method 25A THC results at both the baghouse inlet and outlet. The emission data are presented in parts per million as carbon (ppmc), pounds per hour as carbon (lb/hr), and kilograms per hour (kg/hr).

The total hydrocarbon (THC) emissions for all three runs include fairly stable concentrations with a few spikes occurring during the test periods. The trend data for Runs 1 and 2 are very similar with a stable THC concentration throughout the run with intermittent



spikes. Run 3 is slightly different because there is a substantial baseline concentration shift at about 1000 and then at 1215 the concentration becomes fairly unstable. Graphical presentation of the THC trend can be found in Appendix A. Without accounting for process variations during the testing periods, no absolute determinations can be made about the data.

Table 3-2 shows the minimum, maximum, and average THC concentrations for each run. The one-minute average THC concentrations range from as low as 12.9 ppmc at the stack during Run 3, to as high as 1444 ppmc, during Run 2. This does not mean that the highest spike was 1444 ppmc, but that the highest one minute average was 1444 ppmc. THC emission trends similar to Runs 1, 2, and 3 are what would normally be found at this type of facility.

TABLE 3-2. MINIMUM AND MAXIMUM THC CONCENTRATIONS

Date	Minimum		Minimum		Average	
	ppm <sup>a</sup>	ppmc <sup>b</sup>	ppm	ppmc	ppm	ppmc
<b>Baghouse inlet</b>						
08/27/97	34.2	102.6	176.9	530.7	85.8	257.4
08/28/97	22.6	67.8	481.3	1444	61.4	184.2
08/29/97	5.4	16.2	271.9	815.7	46.1	138.3
<b>Baghouse stack</b>						
08/27/97	22.4	67.2	88.6	265.8	38.3	114.9
08/28/97	19.2	57.6	89.0	267.0	43.6	130.8
08/29/97	4.3	12.9	97.6	292.8	35.7	107.1

<sup>a</sup>ppm - as propane

<sup>b</sup>ppmc - ppm as carbon

The complete Method 25A results are included in Appendix A. The concentrations presented were measured by MRI. The mass emissions data, presented in Section 1.2, were calculated using volumetric flow results provided by PES. The pre- and post-run calibrations and QA checks met the Method 25A criteria in all cases. Calibration QA results are included in Appendix A.

### 3.4 FTIR RESULTS

The FTIR spectra show evidence of aliphatic hydrocarbon compounds in the emissions. Hexane and 2,2,4-trimethylpentane (isooctane) are the only HAP spectra in the EPA library that

meet this description. Therefore, in the draft analysis results, the hydrocarbon emissions were principally represented by “hexane.” Since then, MRI has measured reference spectra of some additional non-HAP hydrocarbon compounds. These new hydrocarbon reference spectra were used in revised analyses of the sample spectra. In the revised results, the hydrocarbon mixture is principally represented by n-heptane with contributions from 1-pentene and 2-methyl-2-butene.

A summary of the FTIR results was presented in Tables 1-1 and 1-2. Complete FTIR results at the inlet and outlet are presented in Tables B-1 to B-4 in Appendix B. The results are presented graphically after Table B-4. The infrared spectra showed evidence of water vapor, carbon dioxide (CO<sub>2</sub>), CO, methane, formaldehyde, sulfur dioxide (SO<sub>2</sub>), toluene, ethylene, and a mixture of aliphatic (non-aromatic) hydrocarbons. A description of the analytical procedures used to prepare the FTIR results is given in Section 4.4. The mass emission rates were calculated using flow data provided by PES. Mass emission calculations for toluene do not include the samples where toluene was spiked from a cylinder in the gas stream and the unspiked concentration was zero..

Some samples in all three test runs were measured on a cold/dry basis by passing the gas through a condenser before the FTIR cell. The condenser was used to remove moisture, which was typically about 30 percent by volume. See Section 1.2 for additional explanation of how condenser can affect the results.

Because moisture is removed from the samples and because the calculated uncertainties depend on the residual noise in the spectra, the calculated uncertainties for non-detects can be lower in the dried samples.

### 3.5 ANALYTE SPIKE RESULTS

An ethylene gas standard (Runs 1 and 3) and a toluene gas standard (Run 2) were used for analyte spiking experiments for quality control evaluation. Preferably, a spike standard combines the analyte and the tracer gas in the same cylinder, but the SF<sub>6</sub> and the analytes were contained in separate cylinders. Therefore, the two components (SF<sub>6</sub> and toluene or SF<sub>6</sub> and ethylene) were spiked sequentially: the flue gas was spiked with SF<sub>6</sub> until three samples were measured, then the flue gas was spiked with the analyte (toluene or ethylene).

The analyte spike results are presented in Tables 3-3 and 3-4. Samples were spiked with a measured flow of analyte vapor during each run and at each location. The SF<sub>6</sub> tracer gas spike

was used to determine the spike dilution factor. A description of the spike procedure is given in Section 4.3.1.

The calculated spike recoveries were within 70 to 100 percent except for the Run 2 toluene spike results at the outlet. The calculated toluene spike concentrations were similar to those measured in the inlet results. But the outlet unspiked toluene concentration was zero. Since the emissions were variable, it may be that the outlet spiked samples contained a contribution from the process emissions. The process contribution may have dropped below detectible levels when the unspiked samples were collected. There was some disagreement between the toluene reference spectra in the EPA spectral library and the spectrum of the toluene cylinder standard measured on-site at Asphalt Plant B. Tables 3-3 and 3-4 present the toluene recoveries obtained using the EPA library toluene spectra. Using the spectrum of the toluene cylinder standard in the analysis gives toluene spike recoveries about 40 percent lower.

TABLE 3-3. SPIKE RESULTS IN WET SAMPLES COLLECTED AT THE BAGHOUSE INLET

Run	Average Concentration			Average SF <sub>6</sub> Concentration				Calc - C <sub>exp</sub>		
	Spike	Unspike	Calc <sup>a</sup>	Spike	Unspike	SF <sub>6</sub> (calc) <sup>a</sup>	DF <sup>b</sup>	C <sub>exp</sub> <sup>c</sup>	Δ <sup>d</sup>	% Recovery
1 (ethylene) <sup>e</sup>	23.2	3.5	19.7	0.878	0.000	0.878	4.4	22.8	-3.1	86.5
2 (toluene) <sup>e</sup>	43.8	15.4	28.4	0.859	0.000	0.859	4.5	26.7	1.7	106.2
3 (ethylene) <sup>e</sup>	28.4	5.7	22.8	0.780	0.000	0.780	5.0	20.2	2.4	112.0

<sup>a</sup> Calc and SF<sub>6</sub>(calc) are equal to the difference between the spiked and unspiked concentrations for the analyte and SF<sub>6</sub>, respectively.

<sup>b</sup> DF is the dilution factor in equation 4.

<sup>c</sup> C<sub>exp</sub> is shown in equation 5.

<sup>d</sup> Δ is equal to the difference, Calc - C<sub>exp</sub>.

<sup>e</sup> Runs 1 and 3 spike gas was 101 ppm ethylene in air. Run 2 spike gas was 121 ppm Toluene standard.

TABLE 3-4. SPIKE RESULTS IN WET SAMPLES AT THE BAGHOUSE OUTLET

Run	Average Concentration			Average SF <sub>6</sub> Concentration				Calc - C <sub>exp</sub>		
	Spike	Unspike	Calc <sup>a</sup>	Spike	Unspike	SF <sub>6</sub> (calc) <sup>a</sup>	DF <sup>b</sup>	C <sub>exp</sub> <sup>c</sup>	Δ <sup>d</sup>	% Recovery
1 (ethylene) <sup>e</sup>	23.2	6.8	16.4	0.758	0.000	0.758	5.1	19.7	-3.3	83.3
2 (toluene) <sup>a</sup>	43.1	0.0	43.1	0.787	0.000	0.787	4.9	24.5	18.6	176.0
3 (ethylene) <sup>e</sup>	35.3	17.7	17.6	0.793	0.000	0.793	4.9	24.7	-7.1	71.2

<sup>a</sup> Calc and SF<sub>6</sub>(calc) are equal to the difference between the spiked and unspiked concentrations for the analyte and SF<sub>6</sub>, respectively.

<sup>b</sup> DF is the dilution factor in equation 4.

<sup>c</sup> C<sub>exp</sub> is shown in equation 5.

<sup>d</sup> Δ is equal to the difference, Calc - C<sub>exp</sub>.

<sup>e</sup> Runs 1 and 3 spike gas was 101 ppm ethylene in air. Run 2 spike gas was 121 ppm Toluene standard.

Table 3-5 presents measured band areas of the EPA toluene reference spectra (deresolved to  $1.0 \text{ cm}^{-1}$ ) and the spectrum of the toluene cylinder standard measured at the Asphalt Plant B test site. The comparison of the band areas does not agree with the comparison of the concentrations (corrected for path length and temperature). The comparisons differ by more than 40 percent. This observed difference predicts that, if the spectra of the toluene cylinder standard is used in the analysis rather than the EPA library spectra, then the resulting toluene spike recovery is more than 40 percent lower.

A similar disagreement was observed in other field tests using this toluene gas standard, and one possibility is that the certified concentration of the toluene cylinder standard was incorrect. However, this was a recently acquired cylinder with a quoted analytical accuracy of  $\pm 2$  percent. This possibility could be evaluated by purchasing several toluene gas standards from different sources and doing a comparison similar to that shown in Table 3-5.

This type of discrepancy is compound specific, and the information in Table 3-5 does not affect the results for any of the other compounds detected. In fact, the deresolved calibration transfer standard (CTS) (ethylene calibration) spectra give a path length result (Section 4) that is consistent with the observed number of laser passes and the instrument resolution. Additionally, this observation is not related to the deresolution of the spectra because the band areas in the original  $0.25 \text{ cm}^{-1}$  toluene spectra are nearly equal to the band areas in the deresolved  $1.0 \text{ cm}^{-1}$  versions of these spectra.

A similar disagreement between reference and standard spectra has been observed at least once previously.<sup>4</sup> In that study, which is included in Appendix D, HCl was the analyte. The spike recovery results were not significantly affected because there was a stable unspiked HCl concentration and because both the spiked and unspiked HCl concentrations were large compared with the disagreement between the reference spectra and the spectra of the cylinder standard.

TABLE 3-5. COMPARISON OF EPA REFERENCE SPECTRA TO SPECTRUM OF TOLUENE CYLINDER STANDARD

Toluene Spectra	Source	Band Area	Frequency Region (cm <sup>-1</sup> )	Spectra comparison based on band areas		Comparison of spectra based on standard concentrations <sup>a</sup>		
				Ratio (Ra)	=1/Ra	(ppm-m)/K	Ratio (Rc)	=1/Rc
153a4ara (1cm <sup>-1</sup> )	EPA library	23.4	3160.8 - 2650.1	5.4	0.184	4.94	4.8	0.210
153a4arc (1cm <sup>-1</sup> )	EPA library	4.3		1.0	1.000	1.04	1.0	1.000
1530828a	Plant B	24.2		5.5	0.181	2.84	2.7	0.365

<sup>a</sup> The comparison of the ratio based on concentrations to the ratio based on band area is equal to 49 percent.

## 4.0 TEST PROCEDURES

The procedures followed in this field test are described in EPA Method 320 for using FTIR spectroscopy to measure HAP's, the EPA Protocol for extractive FTIR testing at industrial point sources, and EPA Method 25A for measuring total gaseous organics. Objectives of the field test were to use the FTIR method to measure emissions from the processes, screen for HAP's in the EPA FTIR reference spectrum library, conduct analyte spiking for quality control assessment, and analyze the spectra for compounds not in the EPA library. Another objective was to monitor the process hydrocarbon emissions using Method 25A. Additionally, manual measurements of gas temperature, gas velocities, moisture, CO<sub>2</sub>, and O<sub>2</sub> by PES were used to calculate the mass emissions rates.

The extractive sampling system shown in Figure 4-1 was used to transport sample gas from the test ports to the FTIR instrument and the THC analyzers.

### 4.1 SAMPLING SYSTEM DESCRIPTION

#### 4.1.1 Sample System Components

The sampling system consists of three separate components:

- two sample probe assemblies
- two sample lines and pumps
- a gas distribution manifold cart.

All wetted surfaces of the system are made of unreactive materials, Teflon<sup>®</sup>, stainless steel, or glass, and are maintained at temperatures at or above 300° F to prevent condensation.

The sample probe assembly consists of the sample probe, a pre-filter, a primary particulate filter, and an electronically actuated spike valve. The sample probe is a standard heated probe assembly with a pitot tube and thermocouple. The pre-filter is a threaded piece of tubing loaded with glass wool attached to the end of sample probe. The primary filter is a Balston particulate filter with a 99 percent removal efficiency at 0.1 μm. The actuated spike valve is controlled by a radio transmitter connected to a switch on the sample manifold cart. All sample probe assembly components are attached to or enclosed in an insulated metal box.

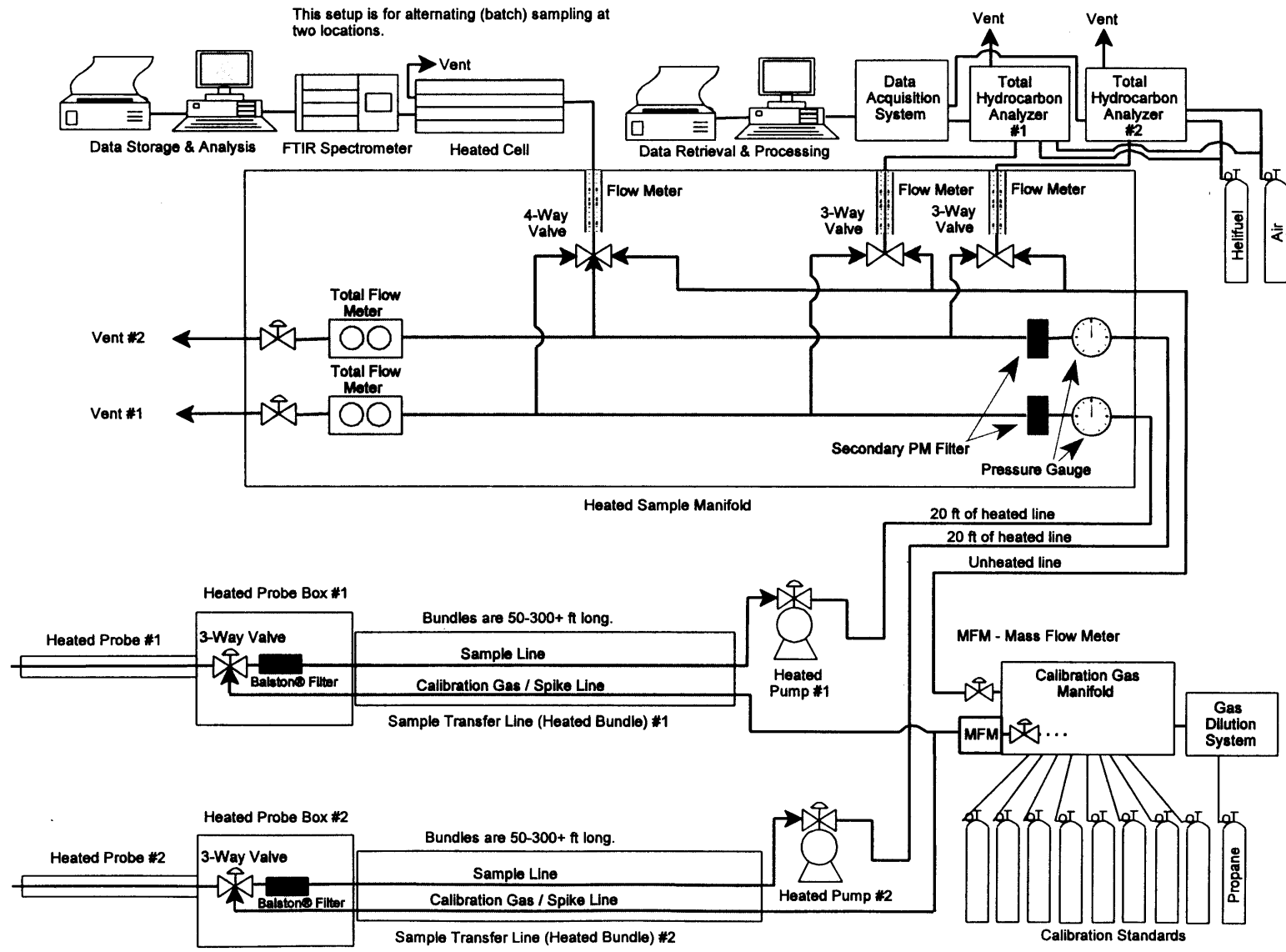

Figure 4-1. Sampling system schematic.



The sample lines are standard heated sample lines with three 3/8 in. teflon tubes in 10, 25, 50, and 100 foot lengths. The pumps are heated, single-headed diaphragm pumps manufactured by either KNF Neuberger or Air Dimensions. These pumps are capable of sampling at rates up to 20 liters per minute (LPM) depending on the pressure drop created by the components installed upstream.

The gas distribution manifold was specially constructed for FTIR sampling by MRI. It is built onto a cart that can be operated inside the MRI mobile lab or in an alternate location, if necessary. The manifold consists of a secondary particulate filter, control valves, rotameters, back pressure regulators and gauges, and a mass flow controller. The manifold can control two sample gas stream inputs, eight calibration gases, and has three individual outputs for analyzers. Also included on the cart is a computer work station and controls for the spike valves and mass flow controller.

#### 4.1.2 Sample Gas Stream Flow

Exhaust gas was withdrawn at both the inlet duct and stack of the baghouse through their respective sample probes and transported to the gas distribution manifold. Inside the manifold the gas passed through separate secondary particulate filters. Downstream of the secondary filters, part of each sample gas stream was directed to separate THC analyzers; one to measure the inlet concentration and another to measure the outlet concentration. Part of the remaining sample gas from each stream was either sent to the FTIR instrument for analysis or exhausted with the remaining portion of the gas stream being sampled (i.e., when the inlet sample was analyzed the stack sample was exhausted and vice versa). This was accomplished by rotating the gas selection valves to allow the appropriate sample gas to pass the instrument inlet port. The gas flow to the instruments was regulated by needle valves on rotameters at the manifold outlets.

The FTIR instrument was used to sample each location alternately; the two THC analyzers were used to sample both locations simultaneously.

## 4.2 FTIR SAMPLING PROCEDURES

Figure 4-1 shows a schematic of the FTIR instrument and connections to the sample distribution manifold.

Sampling was conducted using either the batch or the continuous sampling procedures. All data were collected according to Method 320 sampling procedures, which are described below.

#### 4.2.1 Batch Samples

In this procedure, the valve on the manifold outlet was turned to divert part of the sample flow to the FTIR cell. A positive flow to the main manifold outlet vent was maintained as the cell was filled to just above ambient pressure. The cell inlet valve was then closed to isolate the sample, the cell outlet valve was opened to vent the cell to ambient pressure, the spectrum of the static sample was recorded, and then the cell was evacuated for the next sample.

Batch sampling has the advantage that every sample is an independent sample. The time resolution of the measurements is limited by the interval required to pressurize the cell and record the spectrum; for this test the time resolution was 4 to 5 minutes. All of the spiked samples were collected using this procedure.

#### 4.2.2 Continuous Sampling

The cell was filled as in the batch sampling procedure, but the cell inlet and outlet valves were then opened to keep gas continuously flowing through the cell. The inlet and outlet flows were regulated to keep the sample at ambient pressure. The flow through the cell was maintained at about 5 LPM (about 0.7 cell volumes per min). The cell volume was about 7 liters (L).

The FTIR instrument was automated to record spectra of the flowing sample about every 2 minutes. The analytical program was revised after the field tests and the spectra were analyzed to prepare the results reported in Section 3.

This procedure with automated data collection was used for all of the unspiked testing during all three test runs. Because spectra were collected continuously as the sample flowed through the cell, consecutive samples were mixed. The interval between independent measurements (and the time resolution) depended on the sample flow rate (through the cell), and the cell volume. The following explanation is taken from Performance Specification 15, for continuous operation of FTIR systems.

'The Time Constant, TC, is the period for one cell volume to flow through the cell. The TC determines the minimum interval for complete removal of an analyte from the cell volume. It

depends on the sampling rate ( $R_s$  in LPM), the cell volume ( $V_{\text{cell}}$  in L) and the analyte's chemical and physical properties.' Therefore,

$$TC = \frac{V_{\text{cell}}}{R_s} \quad (1)$$

Performance Specification 15 defines  $5 * TC$  as the minimum interval between independent samples. In this test  $5 * TC$  was about 7 minutes.

A stainless steel tube ran from the cell inlet connection point to the front of the cell. The outlet vent was at the back of the cell so that the flowing sample passed through the greatest portion of the cell volume.

### 4.3 ANALYTE SPIKING

Because no information about possible HAP emissions or flue gas composition was available for this source before the test, validating specific HAP's at this screening test was not planned. MRI conducted spiking for QA purposes using a 101 ppm ethylene standard during Runs 1 and 3 and a toluene (121 ppm in air) standard during Run 2.

#### 4.3.1 Analyte Spiking Procedures

The infrared spectrum is ideally suited for analyzing and evaluating spiked samples because many compounds have distinct infrared spectra.

The reason for analyte spiking is to provide a quality assurance check that the sampling system can transport the spiked analyte(s) to the instrument and that the quantitative analysis program can measure the analyte in the sample gas matrix. If at least 12 (independent) spiked and 12 (independent) unspiked samples are measured, then this procedure can be used to perform a Method 301 validation.<sup>3</sup> No validation was performed at this field test.

The spike procedure follows Sections 9.2 and 13 of EPA draft Method 320 in Appendix D. In this procedure a gas standard is measured directly in the cell. This direct measurement is then compared to measurements of the analyte in spiked samples. Ideally, the spike comprises about 1/10 or less of the spiked sample. The actual dilution ratio depends on the sample flow rate and the spike gas flow rate. The expected concentration ( $C_{\text{exp}}$ , the calculated 100 percent recovery) of the spiked component is determined using a tracer gas,  $\text{SF}_6$ . The  $\text{SF}_6$  concentration in the direct sample divided by the  $\text{SF}_6$  concentration in the spiked sample(s) is

used as the spike dilution factor (DF). The analyte standard concentration divided by DF gives the “expected” value (100 percent) of the spiked analyte recovery.

In this test the analytes (either 121 ppm toluene in air or 101 ppm ethylene in air) and the tracer gas (3.89 ppm SF<sub>6</sub> in nitrogen) were in separate cylinders. The tracer gas and the analyte were spiked in sequence. First, SF<sub>6</sub> was spiked into the flue gas. Three samples spiked with SF<sub>6</sub> were measured. Second, the flue gas was spiked with the analyte using the same flow rate that was used for the SF<sub>6</sub> spike. Three analyte spiked samples were then measured. This procedure works best if the sample flow rate is constant during the spike period.

The spike dilution factor, DF, is determined by comparing the measured SF<sub>6</sub> concentration in the spiked samples, SF<sub>6(spiked)</sub>, to the SF<sub>6</sub> concentration in an undiluted sample direct from the SF<sub>6</sub> cylinder standard, SF<sub>6(direct)</sub>.

$$DF = \frac{SF_{6(direct)}}{SF_{6(spiked)}} \quad (2)$$

where:

DF = the spike dilution factor in Section 9.2.2 of Method 320.

The calculated 100 percent recovery of the analyte spike is analogous to the expected concentration in Section 9.2.2 of Method 320. In this case:

where:

C<sub>exp</sub> = the expected analyte concentration in the spiked samples (100 percent

$$C_{exp} = \frac{\text{analyte}_{(direct)}}{DF} \quad (3)$$

recovery).

Analyte<sub>(direct)</sub> = the concentration of the cylinder standard. In this test the analyte was either toluene or ethylene.

DF = from equation 2.

#### 4.3.2 Analysis of Spiked Results

The analyte and SF<sub>6</sub> concentrations used in the evaluation of the spike recoveries in Tables 3-3 and 3-4 were taken directly from the sample analyses reported in Tables B1 to B4. The concentrations in the spiked samples included a contribution from the spike gas and from analyte present in the flue gas. The component of the analyte concentration attributed to the spike was determined by subtracting the average of the unspiked samples from the measured concentration in each spiked sample ("spiked - unspiked" in Tables 3-3 and 3-4). The percent recoveries were the ratios of the differences, spiked - unspiked, divided by, C<sub>exp</sub> in Section 4.3.1.

#### 4.4 ANALYTICAL PROCEDURES

Analytical procedures in the EPA FTIR Protocol were followed for this test.<sup>2</sup> A computer program was prepared with reference spectra shown in Table 4-1.<sup>5</sup> The computer program used mathematical techniques based on a K-matrix analysis.<sup>6</sup>

Initially, the spectra were reviewed to determine appropriate input for the computer program. Next an analysis was run on all of the sample spectra using all of the reference spectra listed in Table 4-1. Finally, the undetected compounds were removed from the analysis and the spectra were analyzed again using reference spectra only for the detected compounds. The results from this second analytical run are summarized in Tables 1-1 and 1-2 and reported in Appendix B.

The same program used for the analysis also calculated the residual spectra (the difference between the observed and least squares fit absorbance values). Three residuals, one for each of the three analytical regions, were calculated for each sample spectrum. All of the residuals were stored electronically and are included with the electronic copy of the sample data provided with this report. Finally the computer program calculated the standard 1sigma uncertainty for each analytical result, but the reported uncertainties are equal to 4\*sigma.

The concentrations were corrected for differences in absorption path length and temperature between the reference and sample spectra using equation 4.

$$C_{\text{corr}} = \left( \frac{L_r}{L_s} \right) \left( \frac{T_s}{T_r} \right) C_{\text{calc}} \quad (4)$$

where:

$C_{\text{corr}}$  = Concentration, corrected for path length and temperature.

$C_{\text{calc}}$  = Uncorrected sample concentration.

$L_r$  = Cell path length(s) (meters) used in recording the reference spectrum.

$L_s$  = Cell path length (meters) used in recording the Sample spectra.

$T_s$  = Absolute temperature (Kelvin) of the sample gas when confined in the FTIR gas cell.

$T_r$  = Absolute temperature(s) (Kelvin) of gas cell used in recording the reference spectra.

The ambient pressure recorded over the three days of the test averaged about 770 mm Hg. No correction factor for the pressure was applied to the analytical results.

The sample path length was estimated by measuring the number of laser passes through the infrared gas cell. These measurements were recorded in the data records. The actual sample path length,  $L_s$ , was calculated by comparing the sample CTS spectra to CTS (reference) spectra in the EPA FTIR reference spectrum library. The reference CTS spectra, which were recorded with the toluene reference spectra and are included in the EPA library, were used as input for a K-matrix analysis of the CTS spectra collected at the field test. The calculated average cell path length resulting from this analysis and the variation among the sample CTS over the 3 days of testing, are reported in Table 4-2.

#### 4.4.1 Computer Program Input

Table 4-1 presents a summary of the reference spectra input for the computer program used to initially analyze the sample spectra. In the revised analyses, the undetected compounds were removed and reference spectra of hydrocarbons 2-methyl-2-pentene, 3-methylpentane, butane, 2-methyl-1-pentene, n-heptane, 1-pentene, 2-methyl-2-butene, and n-pentane were included in the analysis. Only the hydrocarbons that were detected are shown in Tables 1-1, 1-2, and B-1 to B-4. Table 4-2 summarizes the program input used to analyze the CTS spectra recorded at the field test. The CTS spectra were analyzed as an independent determination of the cell path length. To analyze the CTS spectra, MRI used 0.25  $\text{cm}^{-1}$  spectra "cts0814b" and "cts0814c." These reference CTS spectra were recorded on the same dates as the toluene reference spectra used in the analysis. These spectra were deresolved in the same way as the toluene reference spectra using Section K.2.2 of the EPA FTIR protocol. The program analyzed

the main two ethylene bands centered near 2,989 and 949  $\text{cm}^{-1}$ . Table 4-3 summarizes the results of the CTS analysis. The cell path length from this analysis was used as  $L_s$  in equation 4.

#### 4.4.2 EPA Reference Spectra

The toluene spectra used in the MRI analysis were taken from the EPA reference spectrum library (<http://www.epa.gov/ttn/emc/ftir>). The original sample and background interferograms were truncated to the first 16,384 data points. The new interferograms were then Fourier transformed using Norton-Beer medium apodization and no zero filling. The transformation parameters were chosen to agree with those used to collect the sample absorbance spectra. The new 1.0  $\text{cm}^{-1}$  toluene single beam spectra were combined with their deresolved single beam background spectra and converted to absorbance. This procedure was used to prepare spectral standards for the HAP's and other compounds included in the analysis.

TABLE 4-1. PROGRAM INPUT FOR ANALYSIS OF SAMPLE SPECTRA

Compound name	File name	Analytical Region No. <sup>a</sup>	ISC <sup>b</sup>	Reference	
				Meters	T (K)
Water Hot/wet Condenser	194jsub, 194fsub	1,2,3	100 <sup>b</sup>		
Carbon monoxide	co20829a	1	167.1	22	394
Sulfur dioxide	198c1bsi	2	89.5	22	394
Carbon dioxide	193c1bsc	1,2,3	415 <sup>b</sup>		
Formaldehyde	087c1asa	3	100.0	11.25	373
Benzene	015a4ara	3	496.6	3	298
Methane	196c1bsd	3	80.1	22	394
Methyl bromide	106a4asb	2	485.3	3	298
Toluene	153a4arc	3	103.0	3	298
Methyl chloride	107a4asa	3	501.4	3	298
Methyl chloroform	108a4asc	2	98.8	3	298
1,1-dichloroethane	086b4asa	2	499.1	2.25	373
1,3-butadiene	023a4asc	2	98.4	3	298
Carbon tetrachloride	029a4ase	2	20.1	3	298
Chlorobenzene	037a4arc	2	502.9	3	298
Cumene	046a4asc	3	96.3	3	298
Ethyl benzene	077a4arb	3	515.5	3	298
Hexane	095a4asd	3	101.6	3	298
Methylene chloride	117a4asa	2	498.5	3	298
Propionaldehyde	140b4anc	3	99.4	2.25	373
Styrene	147a4asb	2	550.7	3	298
1,1,2,2-tetrachloroethane	150b4asb	2	493.0	2.25	373
p-Xylene	173a4asa	2	488.2	3	298
o-Xylene	171a4asa	3	497.5	3	298
m-Xylene	172a4arh	2	497.8	3	298
Isooctane	165a4asc	3	101.4	3	298
Ethylene	CTS0827a	2	20.1	10.4	394
SF <sub>6</sub>	Sf6_002	2	4.01	10.4	394
Ammonia	174c1asc	2	500.0	3	298

<sup>a</sup>

Region No.	Upper cm <sup>-1</sup>	Lower cm <sup>-1</sup>
1	2,142.0	2,035.6
2	1,275.0	789.3
3	3,160.8	2,650.1

<sup>b</sup> Indicates an arbitrary concentration was used for the interferant.



TABLE 4-2. PROGRAM INPUT FOR ANALYSIS, CTS SPECTRA,  
AND PATH LENGTH DETERMINATION

Compound name	File name	ASC	ISC	% Difference
Ethylene <sup>a</sup>	cts0814b.spc	1.007	1.014	0.7349
Ethylene	cts0814c.spc	1.007	0.999	0.7350

<sup>a</sup> This spectrum was used in the analysis of the Plant B CTS spectra.

TABLE 4-3. RESULTS OF PATH LENGTH DETERMINATION

CTS spectra	Path length calculations		
20.1 ppm Ethylene	Meters	Delta <sup>a</sup>	% Delta
cts0827A	9.08	-0.02	-0.27
cts0827B	9.00	-0.11	-1.19
cts0828A	9.06	-0.05	-0.53
cts0828B	9.19	0.09	0.96
cts0829A	9.08	-0.03	-0.33
cts0829B	9.23	0.12	1.37
Average Path Length (M)	9.11		
Standard Deviation	0.088		

<sup>a</sup> The difference between the calculated and average values.

#### 4.5 FTIR SYSTEM

A KVB/Analect RFX-40 spectrometer was used to collect all of the data in this field test. The gas cell was a variable path (D-22H) gas cell from Infrared Analysis, Inc. The cell was equipped with a 3-zone insulated heating jacket assembled by MRI. The path length of the cell was set at 20 laser passes and measured to be about 9.11 meters using the CTS reference and sample spectra. The interior cell walls were treated with a Teflon<sup>®</sup> coating to minimize potential analyte losses. A mercury/cadmium/ telluride (MCT) liquid nitrogen detector was used. The spectra were recorded at a nominal resolution of 1.0 cm<sup>-1</sup>.

The optical path length was measured by shining a He/Ne laser through the cell and adjusting the mirror tilt to obtain the desired number of laser spots on the field mirror. Each laser spot indicates two laser passes through the cell. The number of passes was recorded on the field data sheets in Appendix B. The path length in meters was determined by comparing calibration transfer standard (CTS, ethylene in nitrogen) spectra measured in the field to CTS spectra in the EPA reference spectrum library. The procedure for determining the cell path length is described in Section 4.4.

#### 4.6 CONTINUOUS EMISSIONS MONITORING FOR TOTAL HYDROCARBONS (THC)

The guidelines set forth in Method 25A were followed during the sampling at Plant B with two exceptions. Section 7.2 of Method 25A specifies an analyzer drift determination hourly during the test period, but this instruction was not followed. Also, Section 7.2 specifies that the mid-level calibration gas is used for the drift determination. For this test program, the high-level calibration gas was used for the drift determination.

There are two reasons the drift determination was not completed as specified. The first reason is because of continuity in the FTIR and THC sampling. With run length exceeding four hours, drift determinations as specified would have involved off-line periods of up to 10 minutes each hour for the THC analyzers and possibly for the FTIR instrument. The loss of this time could affect the results if significant process events had occurred during these periods. The second reason is that experience with the analyzers MRI was using show them to be stable over extended periods when they are operated in a climate-controlled environment.

The need to do hourly drift determinations is somewhat diminished when the stability of the analyzer is known and when the possibility that being off-line could affect the representativeness of both the FTIR and THC results.

#### 4.6.1 Total Hydrocarbon Sampling Procedures

The THC sampling was conducted continuously from both locations by using of two separate analyzers. The same sample systems used for the FTIR sampling were used for the THC sampling. Sample gas was directed to the analyzers through a separate set of rotameters and control valves. Each test run was conducted from the start to the end of the manual test runs completed by PES. A summary of specific procedures used is given below.

A brief description of each system component follows.

- THC Analyzer- The THC concentration is measured using a flame ionization detector (FID). MRI used two J.U.M. Model VE-7 analyzers. The THC analyzers were operated on the zero to 1000 ppm range throughout the test period. The fuel for the FID is 40% hydrogen and 60% helium mixture.
- Data Acquisition System- MRI uses LABTECH notebook (Windows version), which is an integrated system that provides data acquisition, monitoring and control. The system normally writes data to a disk in the background while performing foreground tasks or displaying data in real time. The averaging period set for this test was one minute.
- Calibration Gases- Calibration gases were prepared from an EPA Protocol 1 cylinder of propane (5278 ppm propane in nitrogen) using an Environics Model 2020 gas dilution system that complies with the requirements of EPA Method 205. High, medium and low standard gases were generated to perform analyzer calibration checks. The raw data is recorded in ppm as propane, but is converted to an as carbon basis for reporting.

#### 4.6.2 Hydrocarbon Emission Calculations

The hydrocarbon data is presented as THC emissions in Table 1-3. To do this the THC emission data was first converted to an as carbon basis using Equation 5, and then the THC emission rate was calculated using Equation 7.

$$C_c = K C_{\text{meas}} \quad (5)$$

where:

$C_c$  = organic concentration as carbon, ppmv.

$C_{\text{meas}}$  = organic concentration as measured, ppmv.

$K$  = carbon equivalent correction factor, 3 for propane.

The emission rate was calculated using Equation 6.

$$E_{\text{THC}} = \frac{\frac{C_{\text{Cc}}}{(1-B_{\text{ws}})} \times \text{MW} \times Q_{\text{std}} \times 60}{385.3 \times 10^6} \quad (6)$$

where:

$E_{\text{THC}}$  = THC mass emission rate, lb/hr.

$B_{\text{ws}}$  = moisture fraction.

$\text{MW}$  = molecular weight of Carbon, 12 lb/lb-mole.

$Q_{\text{std}}$  = volumetric flow rate corrected to standard conditions, dscfm.

60 = conversion to hours, min/hr.

385.3 = molar volume,  $\text{ft}^3/\text{mole}$  at standard conditions.

$10^6$  = conversion for decimal fraction to ppm.

## 5.0 SUMMARY OF QA/QC PROCEDURES

### 5.1 SAMPLING AND TEST CONDITIONS

Before the test, sample lines were checked for leaks and cleaned by purging with moist air (250°F). Following this, the lines were checked for contamination using dry nitrogen. This is done by heating the sampling lines to 250°F and purging with dry nitrogen. The FTIR cell was filled with some of the purging nitrogen and the spectrum of this sample was collected. This single beam spectrum was converted to absorbance using a spectral background of pure nitrogen (99.9 percent) taken directly from a cylinder. The lines were checked again on site before sampling, after each change of location, and after spiking.

During sampling, spectra of at least 10 different samples were collected during each hour (five at each of two locations).

Each spectrum was assigned a unique file name and written to the hard disk and a backup disk under that file name. Each interferogram was also saved under a file name that identifies it with its corresponding absorbance spectrum. All background spectra and calibration spectra were also stored on disks with their corresponding interferograms.

Notes on each calibration and sample spectrum were recorded on hard copy data sheets. Below are listed some sampling and instrument parameters that were documented in these records.

#### **Sampling Conditions**

- Line temperature
- Process conditions
- Sample flow rate
- Ambient pressure
- Time of sample collection

#### **Instrument Configuration**

- Cell volume (for continuous measurements)
- Cell temperature
- Cell path length
- Instrument resolution
- Number of scans co-added

- Length of time to measure spectrum
- Time spectrum was collected
- Time and conditions of recorded background spectrum
- Time and conditions of relevant CTS spectra
- Apodization

Hard copy records were also kept of all flue gas measurements, such as sample flow, temperature, moisture and diluent data.

Effluent was allowed to flow through the entire sampling system for at least 5 minutes before a sampling run started or after changing to a different test location. FTIR spectra were continuously monitored to ensure that there was no deviation in the spectral baseline greater than  $\pm 5$  percent ( $-0.02 \leq \text{absorbance} \leq +0.02$ ). When a deviation greater than  $\pm 5$  percent did occur, sampling was interrupted and a new background spectrum was collected. The run was then resumed until completed or until it was necessary to collect another background spectrum.

## 5.2 FTIR SPECTRA

For a detailed description of QA/QC procedures relating to data collection and analysis, refer to the "Protocol For Applying FTIR Spectrometry in Emission Testing."<sup>2</sup>

A spectrum of the CTS was recorded at the beginning and end of each test day. A leak check of the FTIR cell was also performed according to the procedures in references 1 and 2. The CTS gas was 101 ppm ethylene in air. The CTS spectrum provided a check on the operating conditions of the FTIR instrumentation, e.g., spectral resolution and cell path length. Ambient pressure was recorded whenever a CTS spectrum was collected. The CTS spectra were compared to CTS spectra in the EPA library. This comparison is used to quantify differences between the library spectra and the field spectra so library spectra of HAP's can be used in the quantitative analysis.

Two copies of all interferograms, processed backgrounds, sample spectra, and the CTS were stored on separate computer disks. Additional copies of sample and CTS absorbance spectra were also be stored for data analysis. Sample absorbance spectra can be regenerated from the raw interferograms, if necessary.

The compact disk enclosed with this report contains one complete copy of all of the FTIR data recorded at the Plant B field test. The data are organized into directories whose titles

identify the contents. The continuous data are in directories identified by the date on which the spectra were recorded. The directory titles "BKG," "CTS," "outlet," and "inlet," identify backgrounds, CTS spectra, and spectra of inlet and outlet samples, respectively. Additional sub-directories "AIF" and "ASF" identify interferograms and absorbance spectra, respectively. All of the sample data are in the Analect Instruments software format. The directory "residuals" contains the residual spectra. There are three residual spectra for each sample spectrum, one for each analytical region. The information on the enclosed disk with the data records in Appendix A meets the reporting requirements of the EPA FTIR Protocol and Method 320.

To measure HAP's detected in the gas stream, MRI used spectra from the EPA library, when available.

### 5.3 METHOD 25A

#### 5.3.1 Initial Checks

Before starting the first run, the following system checks were performed.:

1. Zero and Span check of the analyzer;
2. Analyzer linearity check at intermediate levels; and
3. Response time of the system.

Calibration criteria for Method 25A is  $\pm 5$  percent of calibration gas value.

#### 5.3.2 Daily Checks

The following checks were made for each test run:

1. Zero/Span calibration and Linearity check before each test run; and
2. Final Zero and Span calibrations of the analyzer at the end of each test run.

The difference between initial and final zero and span checks agreed within  $\pm 3$  percent of the instrument span.

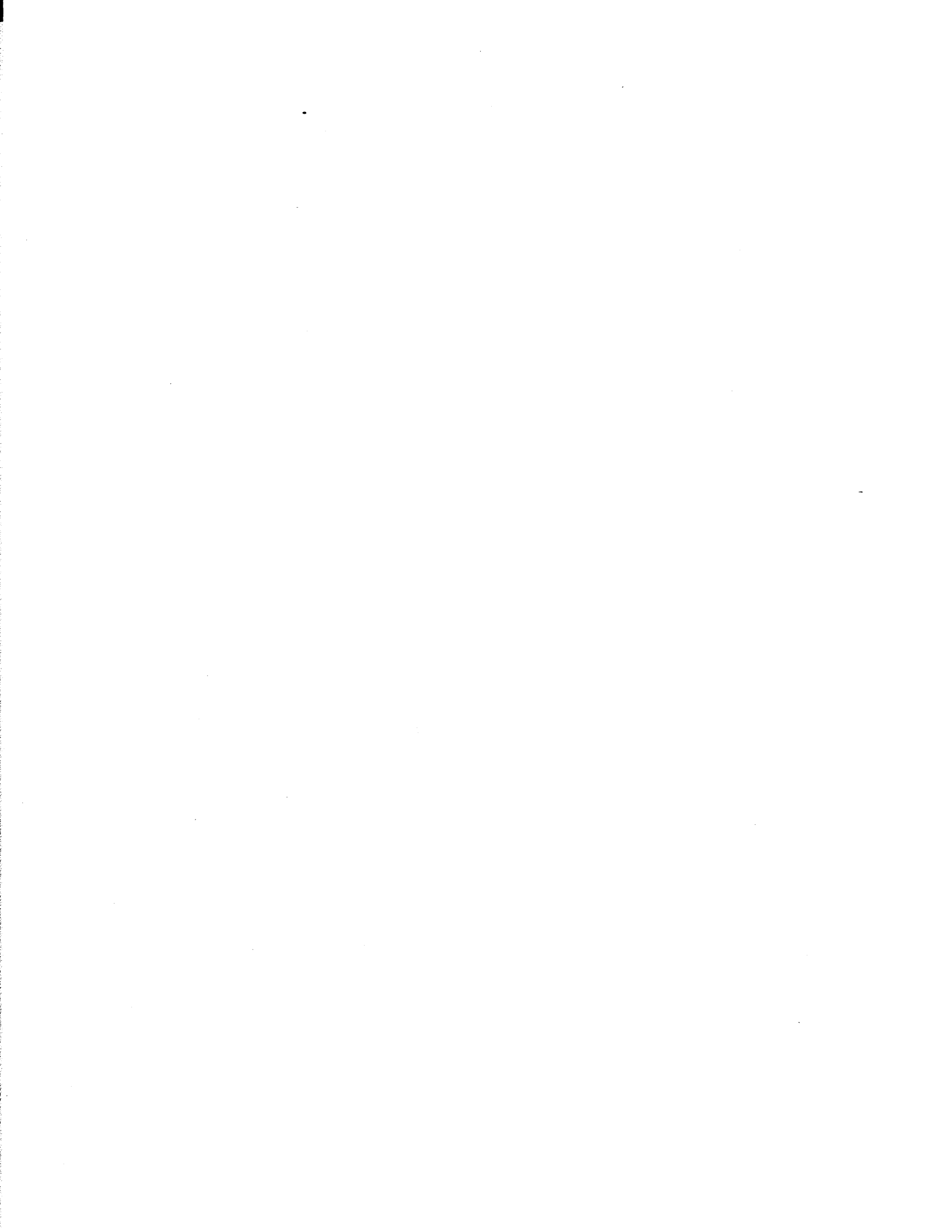



## 6.0 REFERENCES

1. Test Method 320 (Draft) "Measurement of Vapor Phase Organic and Inorganic Emissions by Extractive Fourier Transform Infrared (FTIR) Spectroscopy," **40 CFR Part 63, Appendix A.**
2. "Protocol For The Use of FTIR Spectrometry to Perform Extractive Emissions Testing at Industrial Sources," Revised, EPA Contract No. 68-D2-0165, Work Assignment 3-12, September 1996.
3. "Method 301 - Field Validation of Pollutant Measurement Methods from Various Waste Media," **40 CFR Part 63, Appendix A.**
4. "Validation of EPA FTIR Method For Measuring HCl," T. J. Geyer and G. M. Plummer, Air and Waste Management Association, Paper Number 97-MP74.05, 1997.
5. "An Examination of a Least Squares Fit FTIR Spectral Analysis Method," G. M. Plummer and W. K. Reagen, Air and Waste Management Association, Paper Number 96-WA65.03, 1996.
6. "Computer-Assisted Quantitative Infrared Spectroscopy," Gregory L. McClure (ed.), **ASTM Special Publication 934** (ASTM), 1987.
7. *Emission Factor Documentation for AP-42 Section 11.1, Hot Mix Asphalt Plants*, U. S. Environmental Protection Agency, Research Triangle Park, NC, Fifth Edition.



APPENDIX A

METHOD 25A AND VOLUMETRIC FLOW DATA



A-1 METHOD 25A RESULTS



Run 1  
 Date: 8/27/97  
 Project No: 3804-24-04-03  
 Operator: Gulick

Time (24 hr)	THC Inlet (ppm)	THC Inlet (ppmc)	THC Outlet (ppm)	THC Outlet (ppmc)
8:01	75.2	225.6	45.4	136.2
8:02	77.3	231.9	46.5	139.5
8:03	80.2	240.6	47.0	141
8:04	79.6	238.8	45.5	136.5
8:05	76.8	230.4	43.3	129.9
8:06	77.8	233.4	42.5	127.5
8:07	78.4	235.2	42.4	127.2
8:08	80.0	240.0	42.3	126.9
8:09	82.8	248.4	44.1	132.3
8:10	76.9	230.7	40.4	121.2
8:11	76.9	230.7	39.8	119.4
8:12	74.6	223.8	38.4	115.2
8:13	73.7	221.1	37.5	112.5
8:14	74.9	224.7	37.9	113.7
8:15	77.6	232.8	38.7	116.1
8:16	80.5	241.5	39.8	119.4
8:17	Plant Problem			
8:18				
8:19				
8:20				
8:21				
8:22				
8:23				
8:24				
8:25				
8:26	84.1	252.3	38.1	114.3
8:27	80.7	242.1	36.0	108
8:28	81.2	243.6	36.8	110.4
8:29	82.2	246.6	38.0	114
8:30	83.1	249.3	38.5	115.5
8:31	83.6	250.8	39.1	117.3
8:32	84.2	252.6	39.4	118.2
8:33	85.4	256.2	39.7	119.1
8:34	91.2	273.6	42.8	128.4
8:35	93.5	280.5	44.7	134.1
8:36	96.6	289.8	45.9	137.7
8:37	95.1	285.3	45.5	136.5
8:38	90.3	270.9	42.9	128.7
8:39	87.4	262.2	40.9	122.7
8:40	82.4	247.2	39.4	118.2
8:41	78.5	235.5	36.9	110.7

Run 1  
 Date: 8/27/97  
 Project No: 3804-24-04-03  
 Operator: Gulick

Time (24 hr)	THC Inlet (ppm)	THC Inlet (ppmc)	THC Outlet (ppm)	THC Outlet (ppmc)
8:42	75.6	226.8	35.3	105.9
8:43	74.6	223.8	34.8	104.4
8:44	75.5	226.5	34.7	104.1
8:45	76.6	229.8	35.5	106.5
8:46	75.9	227.7	35.4	106.2
8:47	79.8	239.4	36.6	109.8
8:48	83.4	250.2	37.8	113.4
8:49	86.4	259.2	39.2	117.6
8:50	89.5	268.5	40.9	122.7
8:51	88.3	264.9	40.7	122.1
8:52	87.3	261.9	40.2	120.6
8:53	87.6	262.8	39.9	119.7
8:54	83.2	249.6	38.5	115.5
8:55	84.8	254.4	38.0	114
8:56	87.0	261.0	38.8	116.4
8:57	90.6	271.8	40.3	120.9
8:58	94.2	282.6	42.4	127.2
8:59	96.2	288.6	43.1	129.3
9:00	98.3	294.9	44.1	132.3
9:01	94.8	284.4	42.7	128.1
9:02	90.5	271.5	40.1	120.3
9:03	86.2	258.6	37.9	113.7
9:04	82.6	247.8	35.8	107.4
9:05	85.2	255.6	36.3	108.9
9:06	85.3	255.9	36.8	110.4
9:07	86.1	258.3	37.0	111
9:08	87.0	261.0	37.6	112.8
9:09	87.0	261.0	37.8	113.4
9:10	88.3	264.9	38.3	114.9
9:11	88.2	264.6	38.8	116.4
9:12	85.9	257.7	37.4	112.2
9:13	88.5	265.5	38.3	114.9
9:14	94.2	282.6	40.5	121.5
9:15	97.3	291.9	42.5	127.5
9:16	91.8	275.4	40.3	120.9
9:17	83.9	251.7	36.2	108.6
9:18	79.2	237.6	33.7	101.1
9:19	77.4	232.2	32.8	98.4
9:20	78.7	236.1	33.4	100.2
9:21	80.8	242.4	33.9	101.7
9:22	77.6	232.8	33.1	99.3
9:23	78.3	234.9	33.2	99.6



Run 1  
 Date: 8/27/97  
 Project No: 3804-24-04-03  
 Operator: Gulick

Time (24 hr)	THC Inlet (ppm)	THC Inlet (ppmc)	THC Outlet (ppm)	THC Outlet (ppmc)
9:24	76.4	229.2	32.8	98.4
9:25	76.4	229.2	32.2	96.6
9:26	78.9	236.7	33.6	100.8
9:27	80.3	240.9	34.2	102.6
9:28	80.9	242.7	34.5	103.5
9:29	80.4	241.2	34.0	102
9:30	81.4	244.2	34.2	102.6
9:31	84.2	252.6	35.0	105
9:32	86.4	259.2	36.2	108.6
9:33	82.6	247.8	34.7	104.1
9:34	81.6	244.8	32.7	98.1
9:35	83.6	250.8	33.7	101.1
9:36	85.0	255.0	33.9	101.7
9:37	86.3	258.9	34.5	103.5
9:38	78.0	234.0	35.0	105
9:39	Inlet Spike		35.4	106.2
9:40			35.5	106.5
9:41			35.6	106.8
9:42			36.2	108.6
9:43			36.8	110.4
9:44			37.7	113.1
9:45			37.8	113.4
9:46			37.1	111.3
9:47			36.5	109.5
9:48			35.6	106.8
9:49			34.8	104.4
9:50	80.0	240.0	35.0	105
9:51	78.4	235.2	34.2	102.6
9:52	77.3	231.9	32.9	98.7
9:53	74.9	224.7	31.8	95.4
9:54	75.4	226.2	31.4	94.2
9:55	77.6	232.8	32.4	97.2
9:56	80.3	240.9	33.2	99.6
9:57	81.4	244.2	33.5	100.5
9:58	82.6	247.8	34.3	102.9
9:59	83.2	249.6	34.6	103.8
10:00	82.6	247.8	34.1	102.3
10:01	81.4	244.2	33.3	99.9
10:02	Plant Problem			
10:03				
10:04				
10:05				

Run 1  
 Date: 8/27/97  
 Project No: 3804-24-04-03  
 Operator: Gulick -

Time (24 hr)	THC Inlet (ppm)	THC Inlet (ppmc)	THC Outlet (ppm)	THC Outlet (ppmc)
10:06				
10:07				
10:08				
10:09				
10:10				
10:11				
10:12	86.9	260.7	31.3	93.9
10:13	86.6	259.8	27.3	81.9
10:14	86.2	258.6	27.4	82.2
10:15	86.8	260.4	27.7	83.1
10:16	87.3	261.9	28.0	84
10:17	87.9	263.7	27.7	83.1
10:18	83.9	251.7	26.4	79.2
10:19	86.1	258.3	26.4	79.2
10:20	92.9	278.7	28.6	85.8
10:21	95.4	286.2	29.3	87.9
10:22	94.8	284.4	29.3	87.9
10:23	94.1	282.3	28.6	85.8
10:24	92.5	277.5	28.1	84.3
10:25	91.3	273.9	27.4	82.2
10:26	93.2	279.6	28.2	84.6
10:27	93.2	279.6	28.2	84.6
10:28	94.4	283.2	Outlet Spike	
10:29	93.4	280.2		
10:30	93.2	279.6		
10:31	91.2	273.6		
10:32	89.8	269.4		
10:33	88.2	264.6		
10:34	86.2	258.6		
10:35	83.4	250.2		
10:36	81.4	244.2		
10:37	76.8	230.4		
10:38	72.7	218.1		
10:39	74.1	222.3		
10:40	74.0	222.0		
10:41	75.0	225.0		
10:42	75.9	227.7		
10:43	76.5	229.5		
10:44	78.0	234.0		
10:45	79.7	239.1		
10:46	78.5	235.5		
10:47	75.5	226.5		

Run 1  
 Date: 8/27/97  
 Project No: 3804-24-04-03  
 Operator: Gulick

Time (24 hr)	THC Inlet (ppm)	THC Inlet (ppmc)	THC Outlet (ppm)	THC Outlet (ppmc)
10:48	74.8	224.4	26.7	80.1
10:49	96.1	288.3	26.3	78.9
10:50	71.8	215.4	27.1	81.3
10:51	70.8	212.4	28.1	84.3
10:52	69.2	207.6	28.1	84.3
10:53	67.5	202.5	27.7	83.1
10:54	66.5	199.5	28.0	84
10:55	65.3	195.9	27.5	82.5
10:56	65.2	195.6	27.8	83.4
10:57	66.0	198.0	29.0	87
10:58	66.9	200.7	30.2	90.6
10:59	66.1	198.3	30.2	90.6
11:00	63.5	190.5	28.1	84.3
11:01	65.1	195.3	29.2	87.6
11:02	66.3	198.9	30.6	91.8
11:03	66.8	200.4	31.1	93.3
11:04	67.2	201.6	31.2	93.6
11:05	68.4	205.2	32.3	96.9
11:06	68.2	204.6	32.3	96.9
11:07	66.9	200.7	31.4	94.2
11:08	64.7	194.1	29.6	88.8
11:09	64.1	192.3	29.2	87.6
11:10	64.9	194.7	30.3	90.9
11:11	64.6	193.8	30.1	90.3
11:12	59.1	177.3	30.1	90.3
11:13	42.3	126.9	30.3	90.9
11:14	42.1	126.3	30.4	91.2
11:15	41.0	123.0	30.2	90.6
11:16	39.7	119.1	28.5	85.5
11:17	39.1	117.3	28.2	84.6
11:18	39.5	118.5	28.6	85.8
11:19	40.4	121.2	29.4	88.2
11:20	40.8	122.4	30.4	91.2
11:21	41.0	123.0	31.0	93
11:22	41.3	123.9	31.2	93.6
11:23	41.4	124.2	31.7	95.1
11:24	41.6	124.8	31.7	95.1
11:25	42.3	126.9	32.5	97.5
11:26	42.0	126.0	32.4	97.2
11:27	41.1	123.3	31.4	94.2
11:28	40.5	121.5	30.6	91.8
11:29	43.8	131.4	32.1	96.3

Run 1  
 Date: 8/27/97  
 Project No: 3804-24-04-03  
 Operator: Gulick .

Time (24 hr)	THC Inlet (ppm)	THC Inlet (ppmc)	THC Outlet (ppm)	THC Outlet (ppmc)
11:30	50.3	150.9	32.9	98.7
11:31	63.1	189.3	33.2	99.6
11:32	69.9	209.7	32.5	97.5
11:33	71.8	215.4	32.0	96
11:34	70.3	210.9	30.7	92.1
11:35	69.0	207.0	29.2	87.6
11:36	67.8	203.4	28.4	85.2
11:37	68.4	205.2	28.2	84.6
11:38	74.1	222.3	30.1	90.3
11:39	77.3	231.9	31.3	93.9
11:40	Plant Problem			
11:41				
11:42				
11:43				
11:44				
11:45				
11:46				
11:47				
11:48				
11:49	86.9	260.7	32.1	96.3
11:50	83.3	249.9	30.9	92.7
11:51	83.6	250.8	31.8	95.4
11:52	86.1	258.3	32.4	97.2
11:53	89.6	268.8	34.0	102
11:54	87.6	262.8	33.1	99.3
11:55	86.9	260.7	32.7	98.1
11:56	87.4	262.2	32.6	97.8
11:57	88.7	266.1	33.1	99.3
11:58	88.8	266.4	32.8	98.4
11:59	85.7	257.1	32.0	96
12:00	81.8	245.4	30.5	91.5
12:01	80.8	242.4	29.8	89.4
12:02	81.5	244.5	30.1	90.3
12:03	81.2	243.6	30.1	90.3
12:04	80.9	242.7	29.9	89.7
12:05	82.7	248.1	30.7	92.1
12:06	82.2	246.6	30.9	92.7
12:07	78.7	236.1	29.5	88.5
12:08	76.5	229.5	28.5	85.5
12:09	75.0	225.0	28.1	84.3
12:10	78.8	236.4	28.9	86.7
12:11	79.3	237.9	29.3	87.9

Run 1  
 Date: 8/27/97  
 Project No: 3804-24-04-03  
 Operator: Gulick .

Time (24 hr)	THC Inlet (ppm)	THC Inlet (ppmc)	THC Outlet (ppm)	THC Outlet (ppmc)
12:12	77.5	232.5	28.8	86.4
12:13	75.5	226.5	28.4	85.2
12:14	73.6	220.8	27.7	83.1
12:15	75.0	225.0	28.1	84.3
12:16	72.1	216.3	27.1	81.3
12:17	74.7	224.1	27.6	82.8
12:18	80.1	240.3	29.8	89.4
12:19	83.6	250.8	31.4	94.2
12:20	84.0	252.0	31.8	95.4
12:21	82.5	247.5	31.3	93.9
12:22	81.3	243.9	30.9	92.7
12:23	77.7	233.1	29.4	88.2
12:24	75.4	226.2	28.2	84.6
12:25	73.0	219.0	27.7	83.1
12:26	69.2	207.6	26.3	78.9
12:27	72.7	218.1	26.8	80.4
12:28	76.1	228.3	28.7	86.1
12:29	75.8	227.4	28.5	85.5
12:30	76.0	228.0	28.7	86.1
12:31	76.9	230.7	28.8	86.4
12:32	76.4	229.2	29.0	87
12:33	75.0	225.0	28.5	85.5
12:34	74.1	222.3	28.0	84
12:35	71.0	213.0	27.0	81
12:36	68.7	206.1	25.8	77.4
12:37	68.8	206.4	25.6	76.8
12:38	70.5	211.5	26.2	78.6
12:39	73.1	219.3	27.2	81.6
12:40	75.7	227.1	28.4	85.2
12:41	78.6	235.8	29.5	88.5
12:42	80.9	242.7	30.2	90.6
12:43	75.3	225.9	28.7	86.1
12:44	71.3	213.9	26.8	80.4
12:45	69.1	207.3	25.9	77.7
12:46	66.9	200.7	24.7	74.1
12:47	66.2	198.6	24.5	73.5
12:48	65.8	197.4	24.4	73.2
12:49	66.4	199.2	24.6	73.8
12:50	66.3	198.9	24.6	73.8
12:51	65.5	196.5	24.3	72.9
12:52	64.3	192.9	23.9	71.7
12:53	64.6	193.8	23.5	70.5

Run 1  
 Date: 8/27/97  
 Project No: 3804-24-04-03  
 Operator: Gulick -

Time (24 hr)	THC Inlet (ppm)	THC Inlet (ppmc)	THC Outlet (ppm)	THC Outlet (ppmc)
12:54	64.9	194.7	23.9	71.7
12:55	70.9	212.7	25.5	76.5
12:56	75.7	227.1	27.9	83.7
12:57	77.6	232.8	28.8	86.4
12:58	76.2	228.6	28.5	85.5
12:59	75.0	225.0	28.0	84
13:00	73.8	221.4	27.4	82.2
13:01	71.3	213.9	26.4	79.2
13:02	71.2	213.6	26.3	78.9
13:03	67.0	201.0	24.5	73.5
13:04	66.0	198.0	24.2	72.6
13:05	67.6	202.8	24.7	74.1
13:06	68.7	206.1	25.1	75.3
13:07	70.0	210.0	25.5	76.5
13:08	71.2	213.6	26.4	79.2
13:09	72.2	216.6	26.8	80.4
13:10	72.6	217.8	27.0	81
13:11	72.4	217.2	27.0	81
13:12	71.2	213.6	26.6	79.8
13:13	67.6	202.8	25.2	75.6
13:14	64.0	192.0	23.7	71.1
13:15	65.0	195.0	23.8	71.4
13:16	65.0	195.0	24.0	72
13:17	62.9	188.7	23.2	69.6
13:18	61.1	183.3	22.5	67.5
13:19	61.4	184.2	22.4	67.2
13:20	61.8	185.4	22.6	67.8
13:21	63.6	190.8	23.4	70.2
13:22	65.1	195.3	24.3	72.9
13:23	65.1	195.3	24.2	72.6
13:24	64.6	193.8	23.7	71.1
13:25	64.2	192.6	23.8	71.4
13:26	65.1	195.3	23.7	71.1
13:27	72.5	217.5	26.5	79.5
13:28	81.5	244.5	30.3	90.9
13:29	83.1	249.3	31.6	94.8
13:30	81.4	244.2	30.8	92.4
13:31	81.8	245.4	30.6	91.8
13:32	81.5	244.5	30.1	90.3
13:33	84.6	253.8	31.0	93
13:34	87.1	261.3	32.4	97.2
13:35	89.1	267.3	33.0	99

Run 1  
 Date: 8/27/97  
 Project No: 3804-24-04-03  
 Operator: Gulick

Time (24 hr)	THC Inlet (ppm)	THC Inlet (ppmc)	THC Outlet (ppm)	THC Outlet (ppmc)
13:36	90.4	271.2	33.5	100.5
13:37	89.4	268.2	33.1	99.3
13:38	88.1	264.3	32.3	96.9
13:39	86.0	258.0	31.4	94.2
13:40	84.1	252.3	30.6	91.8
13:41	82.0	246.0	29.6	88.8
13:42	81.9	245.7	29.4	88.2
13:43	84.1	252.3	30.6	91.8
13:44	84.8	254.4	30.9	92.7
13:45	86.3	258.9	31.5	94.5
13:46	86.9	260.7	31.9	95.7
13:47	85.9	257.7	31.4	94.2
13:48	85.4	256.2	31.2	93.6
13:49	84.6	253.8	31.1	93.3
13:50	83.2	249.6	30.3	90.9
13:51	81.5	244.5	29.8	89.4
13:52	81.2	243.6	29.5	88.5
13:53	84.5	253.5	30.6	91.8
13:54	86.0	258.0	31.2	93.6
13:55	86.0	258.0	31.3	93.9
13:56	86.1	258.3	31.1	93.3
13:57	87.7	263.1	31.8	95.4
13:58	88.9	266.7	32.1	96.3
13:59	87.1	261.3	31.4	94.2
14:00	86.1	258.3	31.0	93
14:01	80.7	242.1	29.1	87.3
14:02	80.3	240.9	27.7	83.1
14:03	Plant Problem			
14:04				
14:05				
14:06				
14:07				
14:08				
14:09				
14:10				
14:11				
14:12				
14:13	85.2	255.6	28.1	84.3
14:14	80.8	242.4	26.9	80.7
14:15	80.3	240.9	27.3	81.9
14:16	78.5	235.5	27.4	82.2
14:17	77.5	232.5	27.1	81.3

Run 1  
 Date: 8/27/97  
 Project No: 3804-24-04-03  
 Operator: Gulick

Time (24 hr)	THC Inlet (ppm)	THC Inlet (ppmc)	THC Outlet (ppm)	THC Outlet (ppmc)
14:18	77.8	233.4	27.6	82.8
14:19	80.0	240.0	28.3	84.9
14:20	82.5	247.5	29.6	88.8
14:21	82.4	247.2	29.8	89.4
14:22	80.9	242.7	29.3	87.9
14:23	81.0	243.0	28.8	86.4
14:24	80.2	240.6	28.8	86.4
14:25	79.2	237.6	28.4	85.2
14:26	78.8	236.4	28.2	84.6
14:27	79.0	237.0	28.1	84.3
14:28	84.1	252.3	29.9	89.7
14:29	104.0	312.0	35.4	106.2
14:30	163.1	489.3	62.6	187.8
14:31	176.9	530.7	70.1	210.3
14:32	176.4	529.2	71.5	214.5
14:33	174.1	522.3	71.6	214.8
14:34	171.0	513.0	71.5	214.5
14:35	168.6	505.8	71.6	214.8
14:36	149.1	447.3	65.5	196.5
14:37	141.6	424.8	62.6	187.8
14:38	147.4	442.2	66.7	200.1
14:39	145.3	435.9	67.8	203.4
14:40	149.7	449.1	71.5	214.5
14:41	145.7	437.1	72.0	216
14:42	147.5	442.5	74.4	223.2
14:43	146.4	439.2	75.4	226.2
14:44	148.7	446.1	78.5	235.5
14:45	147.7	443.1	79.9	239.7
14:46	143.8	431.4	79.6	238.8
14:47	142.9	428.7	80.6	241.8
14:48	138.4	415.2	80.2	240.6
14:49	138.3	414.9	80.2	240.6
14:50	136.7	410.1	81.1	243.3
14:51	133.8	401.4	80.2	240.6
14:52	132.9	398.7	80.8	242.4
14:53	133.9	401.7	81.5	244.5
14:54	132.2	396.6	81.0	243
14:55	136.8	410.4	83.4	250.2
14:56	138.4	415.2	84.3	252.9
14:57	140.1	420.3	85.2	255.6
14:58	139.5	418.5	85.0	255
14:59	137.0	411.0	82.8	248.4



Run 1  
 Date: 8/27/97  
 Project No: 3804-24-04-03  
 Operator: Gulick

Time (24 hr)	THC Inlet (ppm)	THC Inlet (ppmc)	THC Outlet (ppm)	THC Outlet (ppmc)
15:00	139.8	419.4	83.5	250.5
15:01	138.5	415.5	82.2	246.6
15:02	140.3	420.9	82.8	248.4
15:03	140.6	421.8	82.5	247.5
15:04	139.7	419.1	81.4	244.2
15:05	139.6	418.8	81.1	243.3
15:06	141.5	424.5	80.6	241.8
15:07	145.4	436.2	82.9	248.7
15:08	144.7	434.1	82.6	247.8
15:09	146.5	439.5	83.2	249.6
15:10	146.3	438.9	82.5	247.5
15:11	152.1	456.3	84.9	254.7
15:12	158.2	474.6	88.3	264.9
15:13	152.6	457.8	86.9	260.7
15:14	153.4	460.2	87.0	261
15:15	155.8	467.4	88.6	265.8
15:16	154.2	462.6	88.5	265.5
15:17	150.6	451.8	86.0	258
15:18	151.0	453.0	86.1	258.3
15:19	105.9	317.7	86.2	258.6
15:20	41.6	124.8	84.6	253.8
15:21	34.2	102.6	81.9	245.7
Minimum=	34.2	102.6	22.4	67.2
Maximum=	176.9	530.7	88.6	265.8
Average=	85.8	257.4	38.3	114.9

Run 1  
Date: 8/27/97  
Project No: 3804-24-04-03  
Operator: Gulick

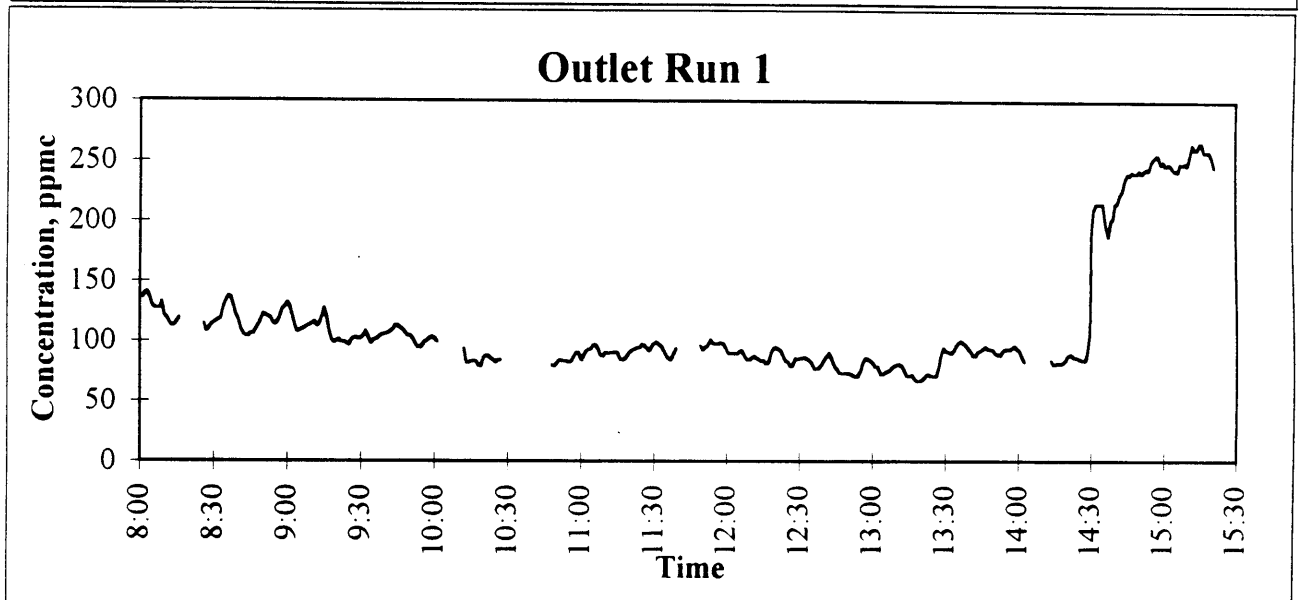
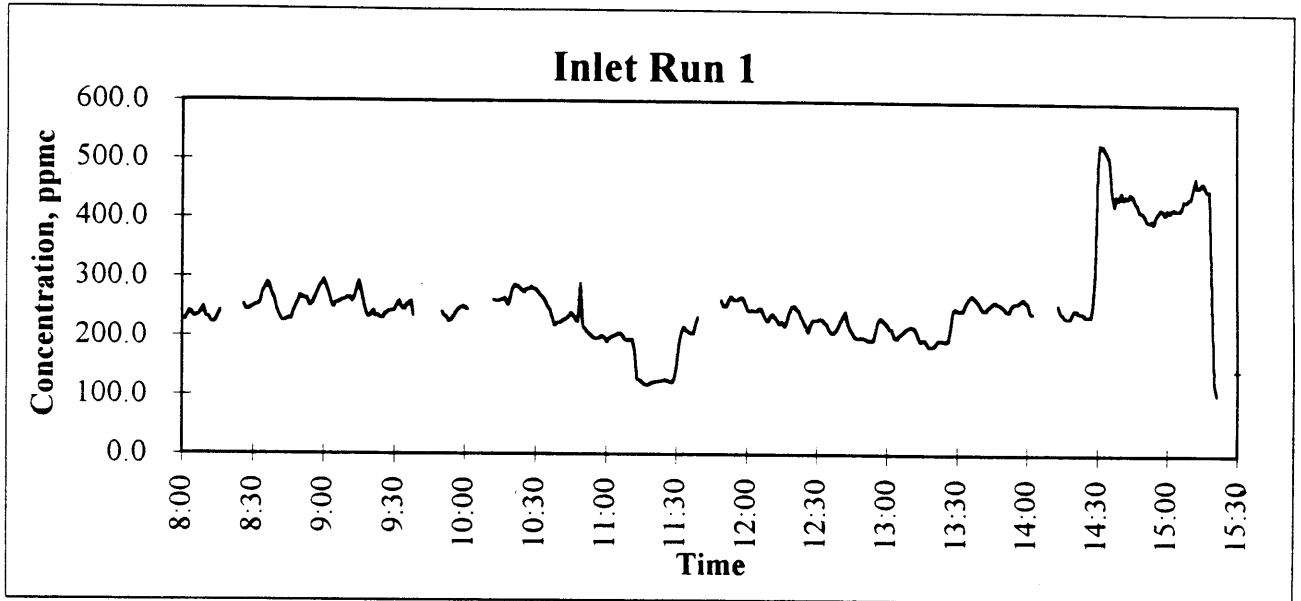

Run 2  
 Date: 8/28/97  
 Project No: 3804-24-04-03  
 Operator: Gulick

Time (24 hr)	THC Inlet (ppm)	THC Inlet (ppmc)	THC Outlet (ppm)	THC Outlet (ppmc)
7:44	69.9	209.7	51.1	153.3
7:45	61.3	183.9	43.9	131.7
7:46	60.6	181.8	42.9	128.7
7:47	61.2	183.6	43.8	131.4
7:48	61.3	183.9	44.3	132.9
7:49	62.2	186.6	44.6	133.8
7:50	63.9	191.7	46.5	139.5
7:51	66.1	198.3	48.1	144.3
7:52	67.1	201.3	49.2	147.6
7:53	68.1	204.3	50.6	151.8
7:54	67.2	201.6	62.1	186.3
7:55	68.5	205.5	Outlet Spike	
7:56	67.9	203.7		
7:57	68.2	204.6		
7:58	69.1	207.3		
7:59	68.2	204.6		
8:00	67.8	203.4		
8:01	68.1	204.3		
8:02	68.0	204.0		
8:03	67.9	203.7		
8:04	68.3	204.9		
8:05	66.7	200.1		
8:06	66.0	198.0		
8:07	67.3	201.9		
8:08	67.4	202.2		
8:09	67.3	201.9		
8:10	66.5	199.5	57.0	171
8:11	65.6	196.8	56.3	168.9
8:12	69.4	208.2	55.8	167.4
8:13	98.8	296.4	53.9	161.7
8:14	99.9	299.7	52.4	157.2
8:15	98.8	296.4	53.1	159.3
8:16	97.5	292.5	51.1	153.3
8:17	96.0	288.0	49.7	149.1
8:18	95.4	286.2	48.8	146.4
8:19	93.8	281.4	47.6	142.8
8:20	93.2	279.6	46.8	140.4
8:21	93.4	280.2	46.4	139.2
8:22	93.3	279.9	46.8	140.4

Run 2  
 Date: 8/28/97  
 Project No: 3804-24-04-03  
 Operator: Gulick

Time (24 hr)	THC Inlet (ppm)	THC Inlet (ppmc)	THC Outlet (ppm)	THC Outlet (ppmc)
8:23	94.5	283.5	48.6	145.8
8:24	94.5	283.5	48.2	144.6
8:25	95.9	287.7	49.9	149.7
8:26	93.4	280.2	48.1	144.3
8:27	78.8	236.4	46.5	139.5
8:28	46.2	138.6	47.3	141.9
8:29	47.2	141.6	48.3	144.9
8:30	48.1	144.3	49.5	148.5
8:31	47.1	141.3	48.8	146.4
8:32	45.7	137.1	47.3	141.9
8:33	44.3	132.9	46.0	138
8:34	45.1	135.3	46.2	138.6
8:35	45.3	135.9	46.5	139.5
8:36	43.3	129.9	46.1	138.3
8:37	39.9	119.7	41.7	125.1
8:38	40.4	121.2	41.6	124.8
8:39	43.1	129.3	44.4	133.2
8:40	46.4	139.2	47.8	143.4
8:41	47.5	142.5	49.7	149.1
8:42	48.9	146.7	50.3	150.9
8:43	50.0	150.0	51.8	155.4
8:44	59.3	177.9	54.0	162
8:45	63.9	191.7	56.7	170.1
8:46	64.8	194.4	57.2	171.6
8:47	64.9	194.7	57.2	171.6
8:48	63.6	190.8	54.5	163.5
8:49	63.0	189.0	54.9	164.7
8:50	63.8	191.4	54.9	164.7
8:51	65.8	197.4	56.7	170.1
8:52	68.6	205.8	59.0	177
8:53	70.3	210.9	60.7	182.1
8:54	72.0	216.0	62.0	186
8:55	73.2	219.6	63.0	189
8:56	73.5	220.5	63.4	190.2
8:57	72.5	217.5	62.4	187.2
8:58	67.5	202.5	60.5	181.5
8:59	53.6	160.8	47.6	142.8
9:00	52.2	156.6	45.0	135
9:01	54.1	162.3	45.6	136.8
9:02	Plant Problem			

Run 2  
 Date: 8/28/97  
 Project No: 3804-24-04-03  
 Operator: Gulick

Time (24 hr)	THC Inlet (ppm)	THC Inlet (ppmc)	THC Outlet (ppm)	THC Outlet (ppmc)
9:03				
9:04				
9:05				
9:06	40.9	122.7	36.2	108.6
9:07	51.6	154.8	30.6	91.8
9:08	69.2	207.6	61.1	183.3
9:09	51.9	155.7	43.6	130.8
9:10	48.5	145.5	39.2	117.6
9:11	54.2	162.6	43.2	129.6
9:12	57.4	172.2	46.9	140.7
9:13	60.9	182.7	49.8	149.4
9:14	60.3	180.9	50.2	150.6
9:15	62.1	186.3	51.7	155.1
9:16	61.1	183.3	51.2	153.6
9:17	60.2	180.6	50.1	150.3
9:18	59.8	179.4	49.6	148.8
9:19	59.8	179.4	49.8	149.4
9:20	59.5	178.5	49.2	147.6
9:21	58.9	176.7	49.0	147
9:22	59.1	177.3	49.0	147
9:23	58.1	174.3	48.4	145.2
9:24	57.5	172.5	47.9	143.7
9:25	58.4	175.2	48.5	145.5
9:26	59.7	179.1	49.8	149.4
9:27	53.9	161.7	46.7	140.1
9:28	50.4	151.2	40.9	122.7
9:29	48.9	146.7	41.3	123.9
9:30	50.6	151.8	41.1	123.3
9:31	52.0	156.0	42.5	127.5
9:32	53.6	160.8	43.5	130.5
9:33	54.7	164.1	44.4	133.2
9:34	55.1	165.3	44.7	134.1
9:35	55.1	165.3	44.8	134.4
9:36	54.3	162.9	43.9	131.7
9:37	53.6	160.8	43.2	129.6
9:38	55.5	166.5	43.8	131.4
9:39	59.4	178.2	48.4	145.2
9:40	53.8	161.4	43.9	131.7
9:41	54.1	162.3	43.6	130.8
9:42	55.1	165.3	44.4	133.2

Run 2  
 Date: 8/28/97  
 Project No: 3804-24-04-03  
 Operator: Gulick -

Time (24 hr)	THC Inlet (ppm)	THC Inlet (ppmc)	THC Outlet (ppm)	THC Outlet (ppmc)
9:43	56.4	169.2	45.1	135.3
9:44	57.4	172.2	46.5	139.5
9:45	57.8	173.4	47.0	141
9:46	59.4	178.2	47.9	143.7
9:47	60.5	181.5	48.9	146.7
9:48	61.6	184.8	49.7	149.1
9:49	58.0	174.0	47.8	143.4
9:50	54.2	162.6	43.2	129.6
9:51	55.9	167.7	44.2	132.6
9:52	57.2	171.6	45.5	136.5
9:53	58.6	175.8	46.9	140.7
9:54	58.6	175.8	46.9	140.7
9:55	58.4	175.2	46.8	140.4
9:56	58.5	175.5	46.8	140.4
9:57	58.6	175.8	47.0	141
9:58	57.9	173.7	46.4	139.2
9:59	54.2	162.6	44.8	134.4
10:00	50.2	150.6	40.5	121.5
10:01	54.1	162.3	43.0	129
10:02	56.9	170.7	46.4	139.2
10:03	58.3	174.9	47.4	142.2
10:04	58.5	175.5	47.4	142.2
10:05	57.9	173.7	46.5	139.5
10:06	58.2	174.6	47.1	141.3
10:07	57.8	173.4	46.6	139.8
10:08	58.0	174.0	46.4	139.2
10:09	54.2	162.6	44.5	133.5
10:10	52.9	158.7	42.2	126.6
10:11	55.2	165.6	44.3	132.9
10:12	56.2	168.6	45.5	136.5
10:13	56.9	170.7	46.0	138
10:14	58.3	174.9	46.8	140.4
10:15	59.5	178.5	47.8	143.4
10:16	59.3	177.9	48.0	144
10:17	55.1	165.3	45.3	135.9
10:18	45.1	135.3	36.8	110.4
10:19	48.2	144.6	37.8	113.4
10:20	49.7	149.1	39.9	119.7
10:21	48.0	144.0	38.2	114.6
10:22	47.8	143.4	38.1	114.3

Run 2  
 Date: 8/28/97  
 Project No: 3804-24-04-03  
 Operator: Gulick .

Time (24 hr)	THC Inlet (ppm)	THC Inlet (ppmc)	THC Outlet (ppm)	THC Outlet (ppmc)
10:23	47.4	142.2	37.4	112.2
10:24	48.4	145.2	38.0	114
10:25	50.8	152.4	40.1	120.3
10:26	51.9	155.7	41.7	125.1
10:27	48.9	146.7	38.9	116.7
10:28	54.4	163.2	41.9	125.7
10:29	59.4	178.2	46.5	139.5
10:30	56.6	169.8	45.9	137.7
10:31	55.2	165.6	43.7	131.1
10:32	56.5	169.5	45.1	135.3
10:33	57.1	171.3	46.3	138.9
10:34	59.1	177.3	47.5	142.5
10:35	61.8	185.4	49.6	148.8
10:36	61.5	184.5	49.7	149.1
10:37	63.3	189.9	51.3	153.9
10:38	63.7	191.1	51.2	153.6
10:39	64.8	194.4	52.3	156.9
10:40	65.5	196.5	52.6	157.8
10:41	58.5	175.5	47.8	143.4
10:42	56.4	169.2	44.1	132.3
10:43	58.3	174.9	45.9	137.7
10:44	59.8	179.4	47.2	141.6
10:45	61.6	184.8	48.7	146.1
10:46	55.3	165.9	45.1	135.3
10:47	54.4	163.2	42.1	126.3
10:48	61.4	184.2	48.5	145.5
10:49	60.3	180.9	48.4	145.2
10:50	57.1	171.3	45.7	137.1
10:51	52.6	157.8	42.1	126.3
10:52	50.4	151.2	39.9	119.7
10:53	53.8	161.4	42.1	126.3
10:54	56.0	168.0	44.1	132.3
10:55	59.0	177.0	46.4	139.2
10:56	56.7	170.1	45.9	137.7
10:57	55.2	165.6	43.6	130.8
10:58	58.1	174.3	47.6	142.8
10:59	54.7	164.1	43.7	131.1
11:00	52.4	157.2	41.3	123.9
11:01	50.7	152.1	39.5	118.5
11:02	50.9	152.7	39.6	118.8

Run 2  
 Date: 8/28/97  
 Project No: 3804-24-04-03  
 Operator: Gulick -

Time (24 hr)	THC Inlet (ppm)	THC Inlet (ppmc)	THC Outlet (ppm)	THC Outlet (ppmc)
11:03	44.0	132.0	35.0	105
11:04	41.7	125.1	32.2	96.6
11:05	43.9	131.7	33.4	100.2
11:06	44.9	134.7	34.7	104.1
11:07	42.3	126.9	32.9	98.7
11:08	41.9	125.7	31.9	95.7
11:09	43.0	129.0	32.8	98.4
11:10	43.9	131.7	33.3	99.9
11:11	44.8	134.4	33.9	101.7
11:12	Plant Problem			
11:13				
11:14				
11:15				
11:16				
11:17				
11:18				
11:19				
11:20	54.4	163.2	87.0	261
11:21	22.6	67.8	19.2	57.6
11:22	56.9	170.7	32.4	97.2
11:23	60.8	182.4	47.8	143.4
11:24	42.4	127.2	31.9	95.7
11:25	33.7	101.1	24.7	74.1
11:26	32.9	98.7	23.3	69.9
11:27	33.3	99.9	23.5	70.5
11:28	34.1	102.3	24.4	73.2
11:29	36.0	108.0	25.3	75.9
11:30	38.0	114.0	27.0	81
11:31	40.6	121.8	29.0	87
11:32	46.9	140.7	32.9	98.7
11:33	54.5	163.5	39.0	117
11:34	60.5	181.5	44.5	133.5
11:35	62.8	188.4	46.5	139.5
11:36	61.6	184.8	46.7	140.1
11:37	64.0	192.0	49.0	147
11:38	61.2	183.6	46.4	139.2
11:39	67.2	201.6	50.3	150.9
11:40	68.6	205.8	52.4	157.2
11:41	67.2	201.6	51.8	155.4
11:42	66.0	198.0	50.5	151.5



Run 2

Date: 8/28/97

Project No: 3804-24-04-03

Operator: Gulick

Time (24 hr)	THC Inlet (ppm)	THC Inlet (ppmc)	THC Outlet (ppm)	THC Outlet (ppmc)
11:43	67.5	202.5	51.4	154.2
11:44	67.5	202.5	51.9	155.7
11:45	67.5	202.5	51.7	155.1
11:46	68.1	204.3	51.9	155.7
11:47	67.8	203.4	52.1	156.3
11:48	70.0	210.0	53.1	159.3
11:49	69.7	209.1	53.6	160.8
11:50	68.0	204.0	51.9	155.7
11:51	71.3	213.9	53.8	161.4
11:52	71.6	214.8	54.5	163.5
11:53	70.8	212.4	53.9	161.7
11:54	68.2	204.6	52.6	157.8
11:55	57.3	171.9	44.4	133.2
11:56	54.1	162.3	40.7	122.1
11:57	54.5	163.5	40.5	121.5
11:58	53.5	160.5	40.4	121.2
11:59	52.9	158.7	39.5	118.5
12:00	53.3	159.9	39.5	118.5
12:01	60.3	180.9	44.4	133.2
12:02	62.8	188.4	47.4	142.2
12:03	61.5	184.5	47.3	141.9
12:04	58.7	176.1	44.8	134.4
12:05	56.4	169.2	42.8	128.4
12:06	55.9	167.7	42.7	128.1
12:07	53.0	159.0	40.6	121.8
12:08	53.5	160.5	39.7	119.1
12:09	56.6	169.8	42.7	128.1
12:10	55.7	167.1	41.8	125.4
12:11	56.0	168.0	42.5	127.5
12:12	55.6	166.8	42.5	127.5
12:13	57.4	172.2	43.4	130.2
12:14	58.9	176.7	44.6	133.8
12:15	56.0	168.0	43.5	130.5
12:16	51.9	155.7	39.3	117.9
12:17	54.3	162.9	40.5	121.5
12:18	57.9	173.7	44.1	132.3
12:19	57.5	172.5	43.9	131.7
12:20	57.2	171.6	44.1	132.3
12:21	59.0	177.0	45.5	136.5
12:22	60.7	182.1	47.0	141

Run 2  
 Date: 8/28/97  
 Project No: 3804-24-04-03  
 Operator: Gulick

Time (24 hr)	THC Inlet (ppm)	THC Inlet (ppmc)	THC Outlet (ppm)	THC Outlet (ppmc)
12:23	60.1	180.3	46.9	140.7
12:24	58.9	176.7	45.9	137.7
12:25	59.1	177.3	45.8	137.4
12:26	57.3	171.9	44.2	132.6
12:27	57.7	173.1	44.2	132.6
12:28	58.9	176.7	45.4	136.2
12:29	59.9	179.7	45.9	137.7
12:30	63.5	190.5	48.6	145.8
12:31	60.6	181.8	48.0	144
12:32	56.7	170.1	43.9	131.7
12:33	54.1	162.3	41.8	125.4
12:34	52.5	157.5	40.2	120.6
12:35	51.2	153.6	38.9	116.7
12:36	50.1	150.3	37.9	113.7
12:37	48.2	144.6	36.4	109.2
12:38	45.0	135.0	33.9	101.7
12:39	43.7	131.1	32.2	96.6
12:40	42.4	127.2	31.3	93.9
12:41	44.0	132.0	32.0	96
12:42	45.9	137.7	33.2	99.6
12:43	47.1	141.3	34.5	103.5
12:44	48.6	145.8	35.5	106.5
12:45	46.9	140.7	34.8	104.4
12:46	44.8	134.4	32.8	98.4
12:47	43.7	131.1	32.2	96.6
12:48	42.5	127.5	31.1	93.3
12:49	42.5	127.5	30.8	92.4
12:50	44.1	132.3	32.0	96
12:51	43.6	130.8	31.4	94.2
12:52	45.5	136.5	32.7	98.1
12:53	43.7	131.1	32.1	96.3
12:54	39.1	117.3	29.0	87
12:55	36.5	109.5	26.2	78.6
12:56	35.9	107.7	25.4	76.2
12:57	34.7	104.1	24.8	74.4
12:58	33.8	101.4	24.2	72.6
12:59	34.4	103.2	24.2	72.6
13:00	35.9	107.7	25.2	75.6
13:01	35.6	106.8	25.3	75.9
13:02	34.1	102.3	24.1	72.3

Run 2  
 Date: 8/28/97  
 Project No: 3804-24-04-03  
 Operator: Gulick

Time (24 hr)	THC Inlet (ppm)	THC Inlet (ppmc)	THC Outlet (ppm)	THC Outlet (ppmc)
13:03	36.6	109.8	25.2	75.6
13:04	34.7	104.1	24.5	73.5
13:05	35.4	106.2	24.7	74.1
13:06	36.9	110.7	26.0	78
13:07	38.0	114.0	27.7	83.1
13:08	37.9	113.7	28.1	84.3
13:09	36.9	110.7	27.1	81.3
13:10	37.0	111.0	27.1	81.3
13:11	38.8	116.4	28.2	84.6
13:12	40.5	121.5	29.5	88.5
13:13	43.8	131.4	32.1	96.3
13:14	45.0	135.0	33.1	99.3
13:15	45.3	135.9	34.2	102.6
13:16	45.5	136.5	34.2	102.6
13:17	46.8	140.4	35.6	106.8
13:18	48.8	146.4	37.1	111.3
13:19	50.1	150.3	38.4	115.2
13:20	51.9	155.7	40.0	120
13:21	52.3	156.9	40.6	121.8
13:22	54.3	162.9	41.6	124.8
13:23	55.2	165.6	43.2	129.6
13:24	57.4	172.2	44.5	133.5
13:25	57.0	171.0	45.0	135
13:26	57.6	172.8	45.0	135
13:27	58.2	174.6	45.8	137.4
13:28	57.6	172.8	45.4	136.2
13:29	56.9	170.7	44.3	132.9
13:30	55.7	167.1	43.7	131.1
13:31	55.5	166.5	43.3	129.9
13:32	54.7	164.1	42.7	128.1
13:33	55.8	167.4	42.7	128.1
13:34	59.0	177.0	45.6	136.8
13:35	60.8	182.4	47.5	142.5
13:36	62.0	186.0	48.7	146.1
13:37	63.3	189.9	49.8	149.4
13:38	63.5	190.5	50.3	150.9
13:39	61.9	185.7	48.9	146.7
13:40	59.9	179.7	47.0	141
13:41	58.0	174.0	44.7	134.1
13:42	56.8	170.4	43.7	131.1

Run 2  
 Date: 8/28/97  
 Project No: 3804-24-04-03  
 Operator: Gulick -

Time (24 hr)	THC Inlet (ppm)	THC Inlet (ppmc)	THC Outlet (ppm)	THC Outlet (ppmc)
13:43	56.1	168.3	42.9	128.7
13:44	56.0	168.0	42.7	128.1
13:45	58.2	174.6	43.7	131.1
13:46	57.6	172.8	44.1	132.3
13:47	55.3	165.9	41.9	125.7
13:48	54.3	162.9	40.7	122.1
13:49	53.1	159.3	40.4	121.2
13:50	53.7	161.1	40.4	121.2
13:51	53.2	159.6	40.1	120.3
13:52	53.3	159.9	39.5	118.5
13:53	52.3	156.9	39.3	117.9
13:54	50.4	151.2	37.1	111.3
13:55	51.3	153.9	38.2	114.6
13:56	108.4	325.2	40.8	122.4
13:57	435.9	1307.7	45.2	135.6
13:58	481.3	1443.9	64.9	194.7
13:59	381.5	1144.5	88.4	265.2
14:00	314.6	943.8	77.7	233.1
14:01	273.3	819.9	72.9	218.7
14:02	245.0	735.0	64.4	193.2
14:03	189.9	569.7	89.0	267
14:04	54.1	162.3	53.8	161.4
14:05	45.9	137.7	23.1	69.3
14:06	95.5	286.5	67.8	203.4
14:07	68.0	204.0	51.6	154.8
14:08	56.4	169.2	40.1	120.3
14:09	52.1	156.3	35.0	105
14:10	50.6	151.8	33.9	101.7
14:11	49.7	149.1	33.2	99.6
14:12	48.9	146.7	32.8	98.4
14:13	48.0	144.0	32.4	97.2
14:14	48.6	145.8	32.4	97.2
14:15	49.2	147.6	33.6	100.8
14:16	49.7	149.1	33.8	101.4
14:17	52.5	157.5	35.5	106.5
14:18	53.2	159.6	36.1	108.3
14:19	53.1	159.3	36.4	109.2
14:20	52.9	158.7	36.4	109.2
14:21	52.5	157.5	36.3	108.9
14:22	52.3	156.9	36.1	108.3

Run 2  
 Date: 8/28/97  
 Project No: 3804-24-04-03  
 Operator: Gulick

Time (24 hr)	THC Inlet (ppm)	THC Inlet (ppmc)	THC Outlet (ppm)	THC Outlet (ppmc)
14:23	51.7	155.1	36.0	108
14:24	51.3	153.9	35.5	106.5
14:25	51.8	155.4	35.8	107.4
14:26	50.8	152.4	35.2	105.6
14:27	49.5	148.5	34.0	102
14:28	49.3	147.9	33.6	100.8
14:29	49.1	147.3	34.0	102
14:30	49.0	147.0	33.6	100.8
14:31	49.4	148.2	33.8	101.4
Minimum=	22.6	<b>67.8</b>	19.2	<b>57.6</b>
Maximum=	481.3	<b>1443.9</b>	89.0	<b>267.0</b>
Average=	61.4	<b>184.1</b>	43.6	<b>130.7</b>

Run 2  
Date: 8/28/97  
Project No: 3804-24-04-03  
Operator: Gulick

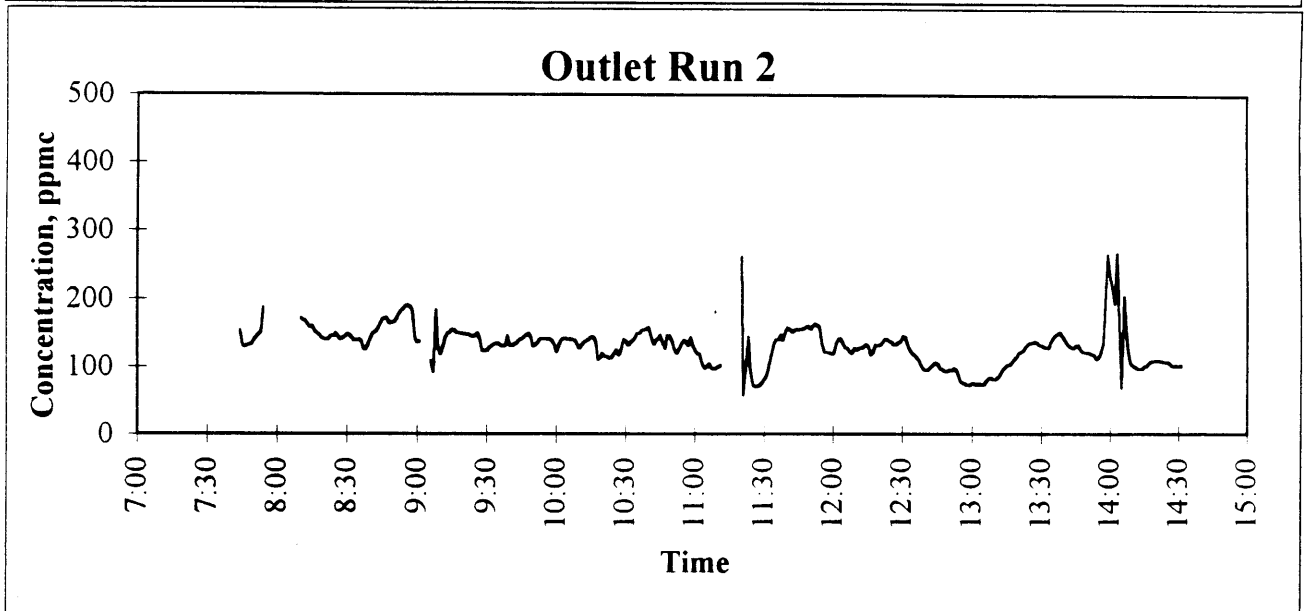
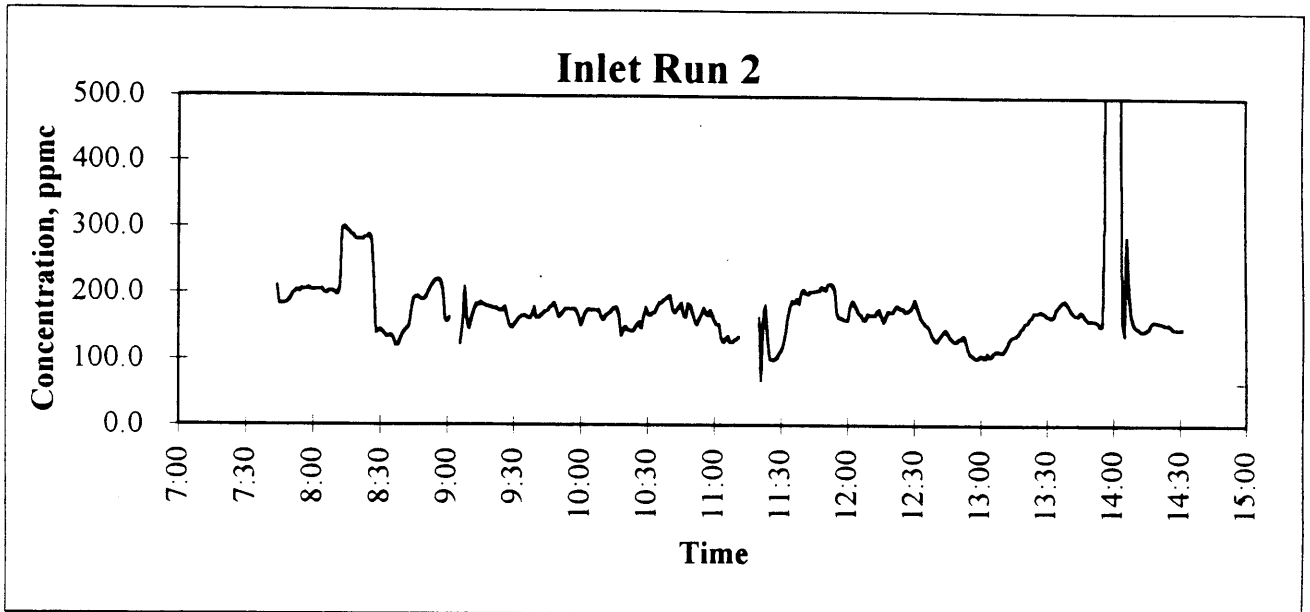

Run 3  
 Date: 8/29/97  
 Project No: 3804-24-04-03  
 Operator: Gulick

Time (24 hr)	THC Inlet (ppm)	THC Inlet (ppmc)	THC Outlet (ppm)	THC Outlet (ppmc)
8:16	20.7	62.1	43.6	130.8
8:17	33.0	99.0	47.0	141
8:18	31.9	95.7	45.9	137.7
8:19	28.4	85.2	36.8	110.4
8:20	22.8	68.4	27.9	83.7
8:21	20.2	60.6	18.5	55.5
8:22	22.1	66.3	22.4	67.2
8:23	32.6	97.8	38.7	116.1
8:24	38.4	115.2	51.9	155.7
8:25	43.2	129.6	61.2	183.6
8:26	48.8	146.4	69.9	209.7
8:27	53.9	161.7	82.9	248.7
8:28	54.3	162.9	85.6	256.8
8:29	53.9	161.7	85.6	256.8
8:30	53.2	159.6	86.4	259.2
8:31	53.9	161.7	87.8	263.4
8:32	54.4	163.2	87.1	261.3
8:33	53.6	160.8	85.9	257.7
8:34	53.6	160.8	85.2	255.6
8:35	53.5	160.5	85.3	255.9
8:36	53.4	160.2	85.2	255.6
8:37	52.3	156.9	85.1	255.3
8:38	52.4	157.2	84.8	254.4
8:39	53.5	160.5	84.3	252.9
8:40	53.4	160.2	84.5	253.5
8:41	53.0	159.0	84.5	253.5
8:42	67.5	202.5	97.6	292.8
8:43	93.9	281.7	82.5	247.5
8:44	95.5	286.5	79.9	239.7
8:45	95.1	285.3	79.5	238.5
8:46	96.4	289.2	79.3	237.9
8:47	96.7	290.1	79.6	238.8
8:48	94.5	283.5	78.1	234.3
8:49	94.9	284.7	78.0	234
8:50	95.2	285.6	77.7	233.1
8:51	93.3	279.9	76.8	230.4
8:52	93.9	281.7	76.7	230.1
8:53	95.4	286.2	77.1	231.3
8:54	94.5	283.5	76.6	229.8
8:55	93.3	279.9	75.6	226.8
8:56	94.5	283.5	76.0	228

Run 3  
 Date: 8/29/97  
 Project No: 3804-24-04-03  
 Operator: Gulick .

Time (24 hr)	THC Inlet (ppm)	THC Inlet (ppmc)	THC Outlet (ppm)	THC Outlet (ppmc)
8:57	95.5	286.5	76.6	229.8
8:58	95.7	287.1	76.6	229.8
8:59	96.7	290.1	77.4	232.2
9:00	98.0	294.0	78.3	234.9
9:01	97.0	291.0	77.5	232.5
9:02	96.6	289.8	77.2	231.6
9:03	97.5	292.5	74.5	223.5
9:04	96.1	288.3	67.6	202.8
9:05	96.3	288.9	66.8	200.4
9:06	96.5	289.5	67.9	203.7
9:07	95.6	286.8	67.2	201.6
9:08	96.4	289.2	67.5	202.5
9:09	97.1	291.3	67.6	202.8
9:10	95.6	286.8	67.5	202.5
9:11	94.0	282.0	65.5	196.5
9:12	94.4	283.2	65.9	197.7
9:13	94.7	284.1	66.6	199.8
9:14	93.8	281.4	65.6	196.8
9:15	94.9	284.7	65.9	197.7
9:16	96.3	288.9	66.9	200.7
9:17	95.0	285.0	66.2	198.6
9:18	95.6	286.8	66.6	199.8
9:19	94.6	283.8	66.2	198.6
9:20	95.6	286.8	66.5	199.5
9:21	95.1	285.3	66.3	198.9
9:22	95.7	287.1	70.3	210.9
9:23	94.9	284.7	78.3	234.9
9:24	93.4	280.2	78.1	234.3
9:25	94.9	284.7	78.2	234.6
9:26	93.4	280.2	78.1	234.3
9:27	94.2	282.6	77.7	233.1
9:28	94.7	284.1	78.8	236.4
9:29	95.0	285.0	78.6	235.8
9:30	93.6	280.8	78.1	234.3
9:31	93.0	279.0	76.6	229.8
9:32	93.5	280.5	77.2	231.6
9:33	93.4	280.2	77.5	232.5
9:34	93.7	281.1	77.8	233.4
9:35	93.6	280.8	77.4	232.2
9:36	93.0	279.0	77.2	231.6
9:37	92.6	277.8	77.0	231
9:38	92.5	277.5	76.2	228.6



Run 3  
 Date: 8/29/97  
 Project No: 3804-24-04-03  
 Operator: Gulick

Time (24 hr)	THC Inlet (ppm)	THC Inlet (ppmc)	THC Outlet (ppm)	THC Outlet (ppmc)
9:39	93.0	279.0	77.0	231
9:40	92.5	277.5	76.0	228
9:41	94.2	282.6	77.0	231
9:42	93.4	280.2	76.9	230.7
9:43	94.0	282.0	76.9	230.7
9:44	95.4	286.2	78.4	235.2
9:45	94.9	284.7	78.3	234.9
9:46	94.7	284.1	78.6	235.8
9:47	95.4	286.2	78.5	235.5
9:48	95.0	285.0	78.2	234.6
9:49	94.1	282.3	77.4	232.2
9:50	94.7	284.1	77.5	232.5
9:51	95.0	285.0	77.8	233.4
9:52	95.3	285.9	78.4	235.2
9:53	93.8	281.4	77.1	231.3
9:54	93.7	281.1	76.9	230.7
9:55	95.4	286.2	78.0	234
9:56	81.3	243.9	70.6	211.8
9:57	66.2	198.6	57.1	171.3
9:58	62.7	188.1	53.0	159
9:59	40.4	121.2	37.2	111.6
10:00	37.6	112.8	31.3	93.9
10:01	37.9	113.7	31.5	94.5
10:02	27.5	82.5	25.3	75.9
10:03	19.9	59.7	17.2	51.6
10:04	20.8	62.4	17.1	51.3
10:05	20.8	62.4	17.7	53.1
10:06	21.0	63.0	17.5	52.5
10:07	22.0	66.0	18.4	55.2
10:08	21.9	65.7	18.1	54.3
10:09	25.3	75.9	20.1	60.3
10:10	26.5	79.5	21.5	64.5
10:11	26.7	80.1	22.0	66
10:12	24.9	74.7	20.7	62.1
10:13	24.2	72.6	19.9	59.7
10:14	33.7	101.1	25.1	75.3
10:15	43.7	131.1	35.3	105.9
10:16	45.3	135.9	36.5	109.5
10:17	47.0	141.0	38.8	116.4
10:18	38.8	116.4	34.1	102.3
10:19	22.7	68.1	20.5	61.5
10:20	9.0	27.0	9.2	27.6

Run 3  
 Date: 8/29/97  
 Project No: 3804-24-04-03  
 Operator: Gulick

Time (24 hr)	THC Inlet (ppm)	THC Inlet (ppmc)	THC Outlet (ppm)	THC Outlet (ppmc)
10:21	6.6	19.8	5.7	17.1
10:22	7.0	21.0	5.8	17.4
10:23	6.7	20.1	5.7	17.1
10:24	6.4	19.2	5.4	16.2
10:25	6.4	19.2	5.3	15.9
10:26	6.4	19.2	5.8	17.4
10:27	6.4	19.2	5.7	17.1
10:28	6.8	20.4	5.7	17.1
10:29	6.9	20.7	5.6	16.8
10:30	6.8	20.4	5.7	17.1
10:31	6.8	20.4	5.8	17.4
10:32	7.1	21.3	5.9	17.7
10:33	7.0	21.0	5.8	17.4
10:34	7.0	21.0	5.9	17.7
10:35	6.9	20.7	5.9	17.7
10:36	6.7	20.1	5.8	17.4
10:37	6.8	20.4	5.7	17.1
10:38	7.0	21.0	5.8	17.4
10:39	7.2	21.6	6.2	18.6
10:40	7.3	21.9	6.1	18.3
10:41	7.3	21.9	6.2	18.6
10:42	7.1	21.3	6.2	18.6
10:43	7.0	21.0	5.9	17.7
10:44	7.1	21.3	6.1	18.3
10:45	7.2	21.6	6.1	18.3
10:46	6.9	20.7	5.8	17.4
10:47	7.1	21.3	5.9	17.7
10:48	7.1	21.3	6.0	18
10:49	6.9	20.7	6.0	18
10:50	7.0	21.0	5.9	17.7
10:51	7.0	21.0	6.2	18.6
10:52	7.2	21.6	6.0	18
10:53	7.1	21.3	6.1	18.3
10:54	7.3	21.9	6.1	18.3
10:55	7.1	21.3	6.1	18.3
10:56	7.0	21.0	6.0	18
10:57	6.9	20.7	5.9	17.7
10:58	6.9	20.7	5.8	17.4
10:59	6.6	19.8	5.7	17.1
11:00	6.5	19.5	5.7	17.1
11:01	6.7	20.1	5.6	16.8
11:02	6.6	19.8	5.7	17.1

Run 3  
 Date: 8/29/97  
 Project No: 3804-24-04-03  
 Operator: Gulick

Time (24 hr)	THC Inlet (ppm)	THC Inlet (ppmc)	THC Outlet (ppm)	THC Outlet (ppmc)
11:03	6.9	20.7	5.7	17.1
11:04	7.1	21.3	5.9	17.7
11:05	6.9	20.7	5.9	17.7
11:06	7.0	21.0	6.0	18
11:07	7.1	21.3	5.9	17.7
11:08	6.7	20.1	6.4	19.2
11:09	6.8	20.4	6.2	18.6
11:10	7.1	21.3	5.8	17.4
11:11	6.9	20.7	6.2	18.6
11:12	7.0	21.0	5.6	16.8
11:13	7.0	21.0	6.1	18.3
11:14	7.2	21.6	6.2	18.6
11:15	7.0	21.0	6.3	18.9
11:16	7.1	21.3	5.6	16.8
11:17	6.5	19.5	5.8	17.4
11:18	6.3	18.9	5.4	16.2
11:19	6.3	18.9	5.4	16.2
11:20	6.3	18.9	5.5	16.5
11:21	6.5	19.5	5.5	16.5
11:22	6.4	19.2	5.5	16.5
11:23	6.5	19.5	5.6	16.8
11:24	6.2	18.6	5.4	16.2
11:25	6.2	18.6	5.4	16.2
11:26	6.0	18.0	5.3	15.9
11:27	5.9	17.7	5.2	15.6
11:28	6.0	18.0	5.3	15.9
11:29	6.0	18.0	5.3	15.9
11:30	6.0	18.0	5.3	15.9
11:31	5.9	17.7	5.3	15.9
11:32	5.9	17.7	5.3	15.9
11:33	5.9	17.7	5.3	15.9
11:34	5.8	17.4	5.4	16.2
11:35	6.0	18.0	5.3	15.9
11:36	6.0	18.0	5.3	15.9
11:37	5.9	17.7	5.3	15.9
11:38	5.9	17.7	5.2	15.6
11:39	5.9	17.7	5.1	15.3
11:40	5.8	17.4	5.1	15.3
11:41	5.7	17.1	5.0	15
11:42	5.9	17.7	5.3	15.9
11:43	5.8	17.4	5.1	15.3
11:44	5.8	17.4	5.1	15.3

Run 3  
 Date: 8/29/97  
 Project No: 3804-24-04-03  
 Operator: Gulick

Time (24 hr)	THC Inlet (ppm)	THC Inlet (ppmc)	THC Outlet (ppm)	THC Outlet (ppmc)
11:45	5.9	17.7	5.3	15.9
11:46	5.9	17.7	5.3	15.9
11:47	5.9	17.7	5.2	15.6
11:48	5.9	17.7	5.2	15.6
11:49	5.8	17.4	5.2	15.6
11:50	5.7	17.1	5.1	15.3
11:51	5.9	17.7	5.2	15.6
11:52	5.9	17.7	5.2	15.6
11:53	5.9	17.7	5.4	16.2
11:54	6.0	18.0	5.4	16.2
11:55	6.1	18.3	5.4	16.2
11:56	5.8	17.4	5.2	15.6
11:57	6.1	18.3	5.2	15.6
11:58	6.0	18.0	5.4	16.2
11:59	5.8	17.4	5.2	15.6
12:00	5.8	17.4	5.3	15.9
12:01	6.0	18.0	5.3	15.9
12:02	5.9	17.7	5.4	16.2
12:03	6.0	18.0	5.4	16.2
12:04	6.2	18.6	5.4	16.2
12:05	6.0	18.0	5.4	16.2
12:06	6.1	18.3	5.4	16.2
12:07	6.1	18.3	5.4	16.2
12:08	6.0	18.0	5.4	16.2
12:09	6.1	18.3	5.4	16.2
12:10	6.3	18.9	5.4	16.2
12:11	6.3	18.9	5.5	16.5
12:12	28.1	84.3	5.4	16.2
12:13	139.7	419.1	8.0	24
12:14	192.9	578.7	15.9	47.7
12:15	155.8	467.4	19.8	59.4
12:16	122.9	368.7	20.4	61.2
12:17	102.4	307.2	19.6	58.8
12:18	77.2	231.6	26.7	80.1
12:19	20.3	60.9	19.0	57
12:20	11.4	34.2	4.6	13.8
12:21	64.2	192.6	37.1	111.3
12:22	35.2	105.6	26.1	78.3
12:23	17.5	52.5	10.8	32.4
12:24	12.5	37.5	7.7	23.1
12:25	10.5	31.5	6.8	20.4
12:26	9.7	29.1	6.6	19.8

Run 3  
 Date: 8/29/97  
 Project No: 3804-24-04-03  
 Operator: Gulick

Time (24 hr)	THC Inlet (ppm)	THC Inlet (ppmc)	THC Outlet (ppm)	THC Outlet (ppmc)
12:27	9.3	27.9	6.8	20.4
12:28	9.2	27.6	6.7	20.1
12:29	8.7	26.1	6.9	20.7
12:30	8.9	26.7	6.9	20.7
12:31	13.9	41.7	9.4	28.2
12:32	33.0	99.0	26.5	79.5
12:33	50.8	152.4	44.4	133.2
12:34	57.5	172.5	53.2	159.6
12:35	61.7	185.1	58.4	175.2
12:36	63.9	191.7	59.8	179.4
12:37	64.6	193.8	60.1	180.3
12:38	64.9	194.7	59.8	179.4
12:39	64.6	193.8	59.1	177.3
12:40	64.9	194.7	59.6	178.8
12:41	63.5	190.5	58.7	176.1
12:42	59.1	177.3	54.7	164.1
12:43	105.7	317.1	50.1	150.3
12:44	269.3	807.9	49.4	148.2
12:45	271.9	815.7	55.9	167.7
12:46	212.3	636.9	55.5	166.5
12:47	172.8	518.4	60.4	181.2
12:48	150.1	450.3	48.3	144.9
12:49	129.9	389.7	53.1	159.3
12:50	113.5	340.5	47.3	141.9
12:51	107.7	323.1	39.6	118.8
12:52	91.4	274.2	38.4	115.2
12:53	88.0	264.0	31.3	93.9
12:54	82.8	248.4	35.8	107.4
12:55	74.2	222.6	35.4	106.2
12:56	71.3	213.9	28.1	84.3
12:57	62.4	187.2	35.9	107.7
12:58	59.8	179.4	37.8	113.4
12:59	54.2	162.6	35.6	106.8
13:00	48.8	146.4	40.9	122.7
13:01	48.6	145.8	34.0	102
13:02	45.3	135.9	34.6	103.8
13:03	40.1	120.3	36.0	108
13:04	39.9	119.7	31.7	95.1
13:05	33.8	101.4	35.1	105.3
13:06	32.5	97.5	30.9	92.7
13:07	30.4	91.2	30.5	91.5
13:08	26.7	80.1	35.2	105.6

Run 3  
 Date: 8/29/97  
 Project No: 3804-24-04-03  
 Operator: Gulick

Time (24 hr)	THC Inlet (ppm)	THC Inlet (ppmc)	THC Outlet (ppm)	THC Outlet (ppmc)
13:09	26.6	79.8	30.0	90
13:10	24.7	74.1	24.9	74.7
13:11	25.2	75.6	21.4	64.2
13:12	24.7	74.1	18.8	56.4
13:13	22.7	68.1	20.1	60.3
13:14	22.9	68.7	17.7	53.1
13:15	20.7	62.1	21.6	64.8
13:16	18.7	56.1	18.1	54.3
13:17	18.3	54.9	18.0	54
13:18	18.9	56.7	14.7	44.1
13:19	17.2	51.6	15.4	46.2
13:20	16.9	50.7	14.2	42.6
13:21	9.3	27.9	17.5	52.5
13:22	5.4	16.2	4.3	12.9
13:23	13.6	40.8	11.4	34.2
13:24	53.0	159.0	44.8	134.4
13:25	21.9	65.7	18.0	54
13:26	25.3	75.9	16.2	48.6
13:27	46.0	138.0	37.8	113.4
13:28	46.0	138.0	38.0	114
13:29	44.9	134.7	36.3	108.9
13:30	44.2	132.6	35.7	107.1
13:31	44.2	132.6	35.8	107.4
13:32	44.2	132.6	35.8	107.4
13:33	44.0	132.0	35.9	107.7
13:34	44.4	133.2	36.3	108.9
13:35	44.6	133.8	36.5	109.5
13:36	45.2	135.6	37.1	111.3
13:37	45.3	135.9	38.0	114
13:38	45.5	136.5	38.5	115.5
13:39	44.7	134.1	37.8	113.4
13:40	44.0	132.0	37.1	111.3
13:41	43.3	129.9	36.6	109.8
13:42	42.1	126.3	35.6	106.8
13:43	42.1	126.3	35.4	106.2
13:44	42.1	126.3	35.1	105.3
13:45	45.6	136.8	37.7	113.1
13:46	46.3	138.9	38.9	116.7
13:47	47.2	141.6	39.7	119.1
13:48	46.2	138.6	39.0	117
13:49	45.8	137.4	38.7	116.1
13:50	45.6	136.8	38.6	115.8

Run 3  
 Date: 8/29/97  
 Project No: 3804-24-04-03  
 Operator: Gulick

Time (24 hr)	THC Inlet (ppm)	THC Inlet (ppmc)	THC Outlet (ppm)	THC Outlet (ppmc)
13:51	45.8	137.4	39.0	117
13:52	45.1	135.3	38.5	115.5
13:53	44.3	132.9	37.7	113.1
13:54	44.7	134.1	37.8	113.4
13:55	44.1	132.3	37.7	113.1
13:56	44.8	134.4	37.7	113.1
13:57	48.3	144.9	40.4	121.2
13:58	54.2	162.6	46.4	139.2
13:59	53.6	160.8	46.5	139.5
14:00	53.2	159.6	45.5	136.5
14:01	54.3	162.9	46.5	139.5
14:02	54.3	162.9	46.3	138.9
14:03	55.0	165.0	46.9	140.7
14:04	54.5	163.5	46.6	139.8
14:05	54.6	163.8	46.8	140.4
14:06	53.7	161.1	46.3	138.9
14:07	53.1	159.3	45.3	135.9
14:08	53.5	160.5	45.1	135.3
14:09	54.3	162.9	46.2	138.6
14:10	54.2	162.6	46.6	139.8
14:11	52.3	156.9	44.6	133.8
14:12	52.0	156.0	44.7	134.1
Minimum=	5.4	16.2	4.3	12.9
Maximum=	271.9	815.7	97.6	292.8
Average=	46.1	138.2	35.7	107.2

Run 3  
Date: 8/29/97  
Project No: 3804-24-04-03  
Operator: Gulick

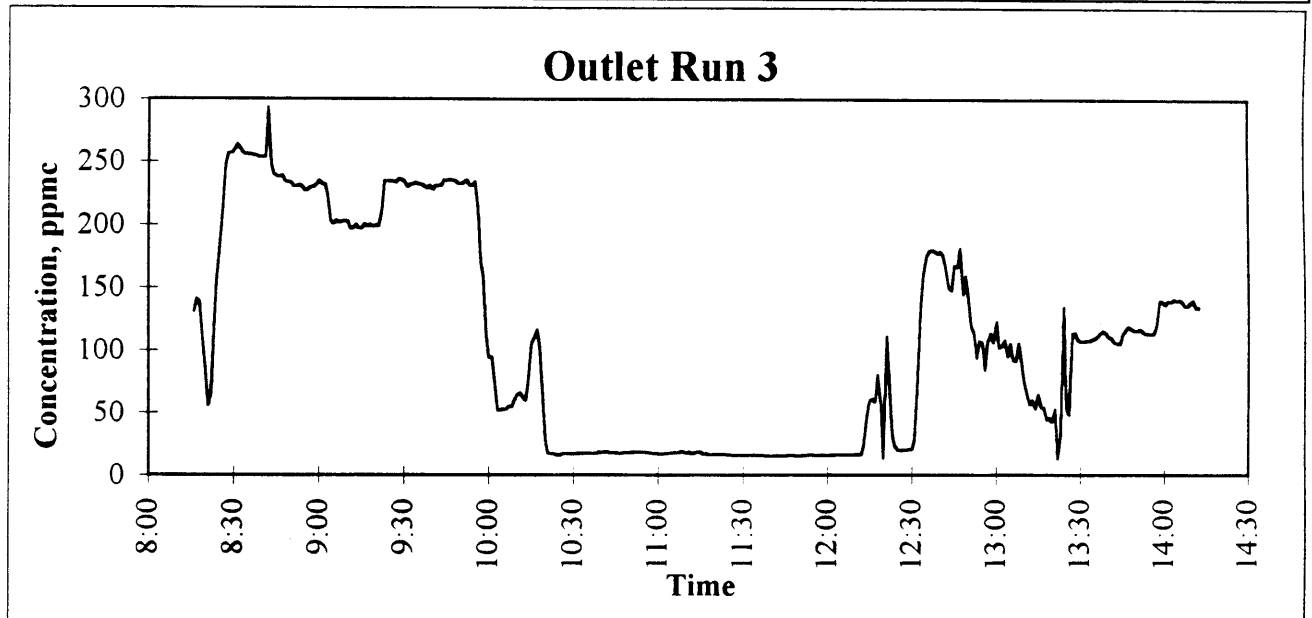
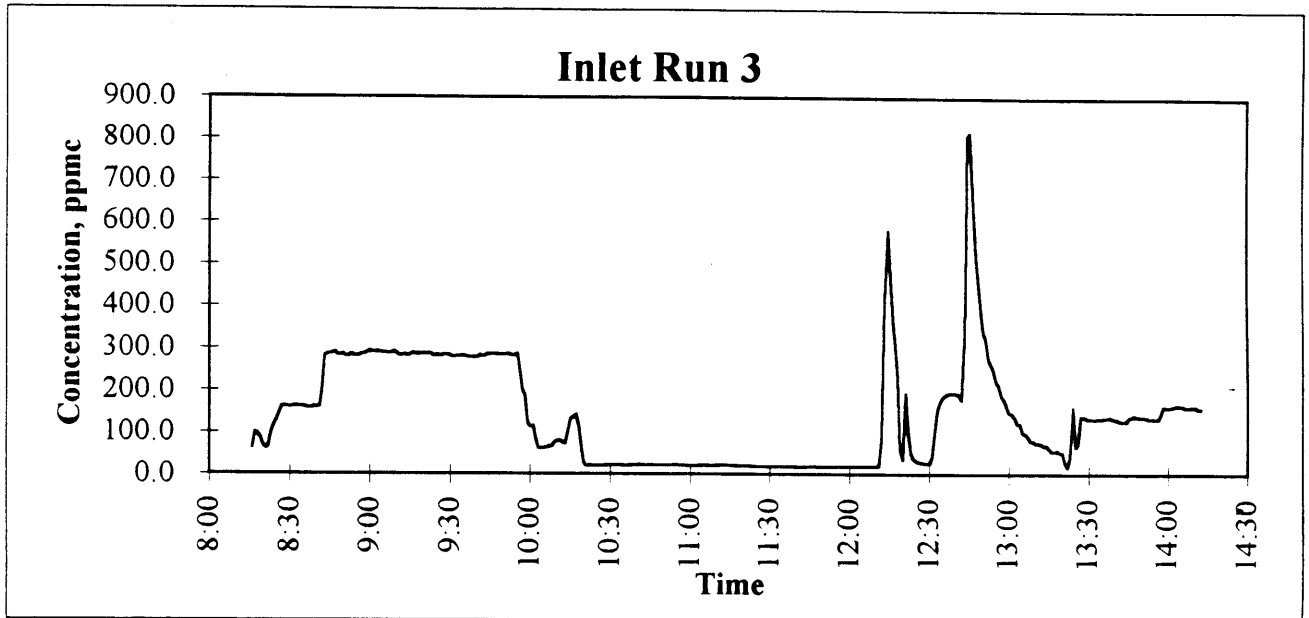



A-2 METHOD 25A CALIBRATION AND QC CHECK DATA



**Calibration Error Determination for 8/27/97**

	<b>Cal Gas Value</b>	<b>Predicted Value</b>	<b>Measured Value</b>	<b>Difference as % of Cal Gas</b>	<b>Pass/Fail</b>
THC 1	0.0		0.0	0.0	Pass
Inlet	898.0		917.0	2.1	Pass
	502.0	512.6	505.0	1.5	Pass
	251.0	256.3	247.0	3.6	Pass
THC 2	0.0		1.4	0.1	Pass
Outlet	898.0		917.0	2.1	Pass
	502.0	513.2	509.0	0.8	Pass
	251.0	257.3	251.0	2.5	Pass

Pass/Fail Criteria is +/- 5% of Calibration Gas

**Calibration Drift determination for 8/27/97**

**Zero Drift**

	<b>Initial Value</b>	<b>Final Value</b>	<b>Difference as % of Span</b>	<b>Pass/Fail</b>
THC 1	0.0	0.7	0.1	Pass
Inlet				
THC 2	1.4	3.7	0.2	Pass
Outlet				

Instrument Span for THC 1 and 2 is 1000 ppm  
Pass/Fail Criteria is +/- 3% of Instrument Span

**Span Drift**

	<b>Initial Value</b>	<b>Final Value</b>	<b>Difference as % of Span</b>	<b>Pass/Fail</b>
THC 1	917.0	909.0	0.8	Pass
Inlet				
THC 2	917.0	928.0	1.1	Pass
Outlet				

Instrument Span for THC 1 and 2 is 1000 ppm  
Pass/Fail Criteria is +/- 3% of Instrument Span

**Calibration Error Determination for 8/28/97**

	<b>Cal Gas Value</b>	<b>Predicted Value</b>	<b>Measured Value</b>	<b>Difference as % of Cal Gas</b>	<b>Pass/Fail</b>
THC 1	0.0		0.4	0.0	
Inlet	898.0		909.0	1.2	Pass
	502.0	508.3	504.0	0.9	Pass
	251.0	254.4	248.0	2.5	Pass
THC 2	0.0		1.8	0.2	Pass
Outlet	898.0		913.0	1.7	Pass
	502.0	511.2	505.0	1.2	Pass
	251.0	256.5	248.0	3.3	Pass

Pass/Fail Criteria is +/- 5% of Calibration Gas

**Calibration Drift determination for 8/28/97**

**Zero Drift**

	<b>Initial Value</b>	<b>Final Value</b>	<b>Difference as % of Span</b>	<b>Pass/Fail</b>
THC 1	0.4	0.2	0.0	Pass
Inlet				
THC 2	1.8	2.1	0.0	Pass
Outlet				

Instrument Span for THC 1 and 2 is 1000 ppm  
Pass/Fail Criteria is +/- 3% of Instrument Span

**Span Drift**

	<b>Initial Value</b>	<b>Final Value</b>	<b>Difference as % of Span</b>	<b>Pass/Fail</b>
THC 1	909.0	908.0	0.1	Pass
Inlet				
THC 2	913.0	915.0	0.2	Pass
Outlet				

Instrument Span for THC 1 and 2 is 1000 ppm  
Pass/Fail Criteria is +/- 3% of Instrument Span

**Calibration Error Determination for 8/29/97**

	<b>Cal Gas Value</b>	<b>Predicted Value</b>	<b>Measured Value</b>	<b>Difference as % of Cal Gas</b>	<b>Pass/Fail</b>
THC 1	0.0		0.8	0.1	Pass
Inlet	898.0		902.0	0.4	Pass
	502.0	504.6	505.0	0.1	Pass
	251.0	252.7	248.0	1.9	Pass
THC 2	0.0		0.2	0.0	Pass
Outlet	898.0		910.0	1.3	Pass
	502.0	508.8	506.0	0.5	Pass
	251.0	254.5	249.0	2.2	Pass

Pass/Fail Criteria is +/- 5% of Calibration Gas

**Calibration Drift determination for 8/29/97**

**Zero Drift**

	<b>Initial Value</b>	<b>Final Value</b>	<b>Difference as % of Span</b>	<b>Pass/Fail</b>
THC 1 Inlet	0.8	0.9	0.0	Pass
THC 2 Outlet	0.2	0.9	0.1	Pass

Instrument Span for THC 1 and 2 is 1000 ppm  
Pass/Fail Criteria is +/- 3% of Instrument Span

**Span Drift**

	<b>Initial Value</b>	<b>Final Value</b>	<b>Difference as % of Span</b>	<b>Pass/Fail</b>
THC 1 Inlet	902.0	900.0	0.2	Pass
THC 2 Outlet	910.0	916.0	0.6	Pass

Instrument Span for THC 1 and 2 is 1000 ppm  
Pass/Fail Criteria is +/- 3% of Instrument Span

## Response Times

THC 1 Inlet	32 Seconds
THC 2 Outlet	29 Seconds

A-3 VOLUMETRIC FLOW DATA





### Summary of Stack Gas Parameters and Test Results

North Carolina

US EPA Test Method 23 - PCDD / PCDF

Baghouse Inlet

Page 1 of 6

RUN NUMBER		R-M23-I-1	R-M23-I-2	R-M23-I-3	
RUN DATE		8/27/97	8/28/97	8/29/97	Average
RUN TIME		0940-1227	0908-1428	0818-1413	
<b>MEASURED DATA</b>					
$\gamma$	Meter Box Correction Factor	1.021	1.021	1.021	1.021
$\Delta H$	Avg Meter Orifice Pressure, in. H <sub>2</sub> O	1.21	0.286	0.396	0.631
$P_{bar}$	Barometric Pressure, inches Hg	29.80	29.60	29.60	29.67
$V_m$	Sample Volume, ft <sup>3</sup>	58.283	53.015	83.709	64.996
$T_m$	Average Meter Temperature, °F	96	96	93	95
$P_{static}$	Stack Static Pressure, inches H <sub>2</sub> O	-1.8	-1.8	-1.8	-1.80
$T_s$	Average Stack Temperature, °F	308	308	290	301
$V_c$	Condensate Collected, ml	510.5	414.9	393.0	439.5
CO <sub>2</sub>	Carbon Dioxide content, % by volume	5.2	5.2	4.0	4.8
O <sub>2</sub>	Oxygen content, % by volume	13.8	13.1	15.2	14.0
N <sub>2</sub>	Nitrogen content, % by volume	81.0	81.7	80.8	81.2
$C_p$	Pitot Tube Coefficient	0.84	0.84	0.84	0.84
$\Delta p^{1/2}$	Average Square Root Dp, (in. H <sub>2</sub> O) <sup>1/2</sup>	0.6901	0.8755	0.7133	0.6930
$\Theta$	Sample Run Duration, minutes	96	170	240	169
$D_n$	Nozzle Diameter, inches	0.257	0.194	0.194	0.215
<b>CALCULATED DATA</b>					
$A_n$	Nozzle Area, ft <sup>2</sup>	0.00036	0.00021	0.00021	0.00026
$V_{m(Std)}$	Standard Meter Volume, dscf	56.399	50.886	80.735	62.673
$V_{m(Std)}$	Standard Meter Volume, dscm	1.597	1.441	2.286	1.775
$P_s$	Stack Pressure, inches Hg	29.67	29.47	29.47	29.53
$B_{wet}$	Moisture, % by volume	29.9	27.7	18.6	25.4
$B_{wet(Std)}$	Moisture (at saturation), % by volume	522.4	512.8	403.1	479.4
$V_{wet(Std)}$	Standard Water Vapor Volume, ft <sup>3</sup>	24.029	19.529	18.499	20.686
$1-B_{wet}$	Dry Mole Fraction	0.701	0.723	0.814	0.746
$M_g$	Molecular Weight (d.b.), lb/lb-mole	29.38	29.36	29.25	29.33
$M_w$	Molecular Weight (w.b.), lb/lb-mole	25.98	26.21	27.15	26.45
$V_s$	Stack Gas Velocity, ft/s	49.5	48.3	49.6	49.1
$A$	Stack Area, ft <sup>2</sup>	16.20	16.20	16.20	16.20
$Q_s$	Stack Gas Volumetric flow, acfm	48,074	48,957	48,211	47,747
$Q_s$	Stack Gas Volumetric flow, dscfm	22,981	23,027	27,178	24,395
$Q_{s(Ormm)}$	Stack Gas Volumetric flow, dscmm	650.7	652.1	789.6	690.8
$I$	Isokinetic Sampling Ratio, %	115.0	102.6	97.7	105.1

**Summary of Stack Gas Parameters and Test Results**  
**US EPA EMC Asphalt Concrete Emissions Testing**  
**US EPA Test Method 29 - Multiple Metals**  
**Baghouse Inlet**  
**Page 1 of 4**

<i>RUN NUMBER</i>		<i>R-M29-I1</i>	<i>R-M29-I2</i>	<i>R-M29-I3</i>	
<i>RUN DATE</i>		<i>8/27/97</i>	<i>8/28/97</i>	<i>8/29/97</i>	<i>Average</i>
<i>RUN TIME</i>		<i>-1000--1200</i>	<i>1019-1427</i>	<i>0819-1403</i>	
<b>MEASURED DATA</b>					
$\gamma$	Meter Box Correction Factor	1.016	1.016	1.016	1.016
$\Delta H$	Avg Meter Orifice Pressure, in. H <sub>2</sub> O	1.24	0.298	0.400	0.347
$P_{bar}$	Barometric Pressure, inches Hg	29.80	29.60	29.60	29.67
$V_m$	Sample Volume, ft <sup>3</sup>	52.232	64.379	85.398	67.338
$T_m$	Average Meter Temperature, °F	101	102	96	100
$P_{static}$	Stack Static Pressure, inches H <sub>2</sub> O	-1.8	-1.8	-1.8	-1.80
$T_s$	Average Stack Temperature, °F	304	309	289	300
$V_{ic}$	Condensate Collected, ml	422.5	485.0	403.9	437.1
$CO_2$	Carbon Dioxide content, % by volume	4.6	5.2	4.0	4.6
$O_2$	Oxygen content, % by volume	14.2	13.1	15.2	14.2
$N_2$	Nitrogen content, % by volume	81.2	81.7	80.8	81.2
$C_p$	Pitot Tube Coefficient	0.84	0.84	0.84	0.84
$\Delta p^{1/2}$	Average Square Root $\Delta p$ , (in. H <sub>2</sub> O) <sup>1/2</sup>	0.6972	0.6977	0.7185	0.7045
$\Theta$	Sample Run Duration, minutes	87	200	240	176
$D_n$	Nozzle Diameter, inches	0.258	0.194	0.196	0.215
<b>CALCULATED DATA</b>					
$A_n$	Nozzle Area, ft <sup>2</sup>	0.000357	0.000205	0.000210	0.000257
$V_{m(std) \text{ or}}$	Standard Meter Volume, ft <sup>3</sup>	49.883	60.783	81.522	64.063
$V_{m(std) \text{ cm}}$	Standard Meter Volume, m <sup>3</sup>	1.413	1.721	2.308	1.814
$Q_m$	Average Sampling Rate, dscfm	0.573	0.304	0.340	0.406
$P_s$	Stack Pressure, inches Hg	29.67	29.47	29.47	29.53
$B_{ws}$	Moisture, % by volume	28.5	27.3	18.9	24.9
$B_{ws(est)}$	Moisture (at saturation), % by volume	491.9	532.3	395.0	473.1
$V_{ws(est)}$	Standard Water Vapor Volume, ft <sup>3</sup>	19.887	22.829	19.012	20.576
$1-B_{ws}$	Dry Mole Fraction	0.715	0.727	0.811	0.751
$M_d$	Molecular Weight (d.b.), lb/lb-mole	29.30	29.36	29.25	29.30
$M_s$	Molecular Weight (w.b.), lb/lb-mole	26.08	26.26	27.12	26.49
$V_s$	Stack Gas Velocity, ft/s	49.7	49.9	49.9	49.9
$A$	Stack Area, ft <sup>2</sup>	16.20	16.20	16.20	16.20
$Q_s$	Stack Gas Volumetric flow, acfm	48,345	48,535	48,550	48,477
$Q_s \text{ cfm}$	Stack Gas Volumetric flow, dscfm	23,687	23,865	27,325	24,959
$Q_s \text{ cmm}$	Stack Gas Volumetric flow, dscmm	671	676	774	707
$I$	Isokinetic Sampling Ratio, %	109.7	100.5	96.1	102.1

BAG  
IIV

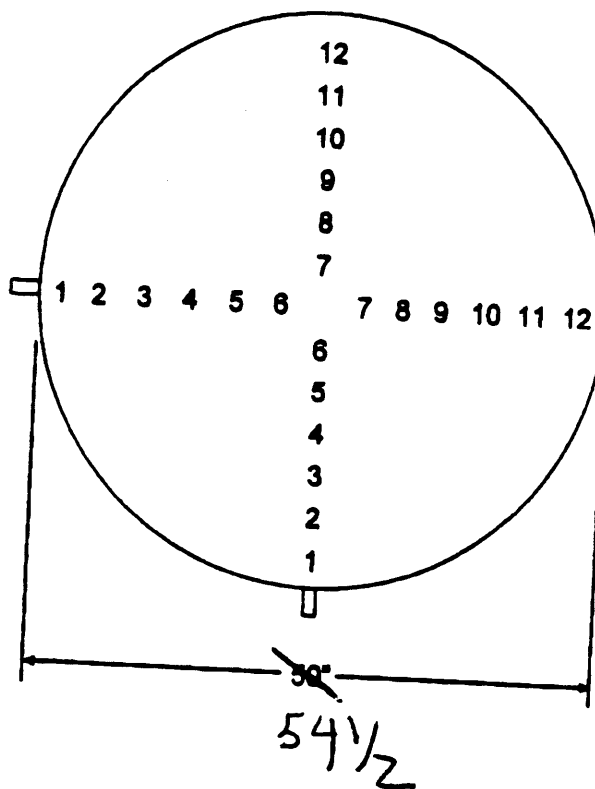

Section A

Traverse Point No.	Distance From Inside Wall, inches
1	1.05
2	3.35
3	5.90
4	8.85
5	12.5
6	17.8
7	32.2
8	37.5
9	41.2
10	44.1
11	46.7
12	49.0

### Summary of Stack Gas Parameters and Test Results

Cary, North Carolina

US EPA Test Method 23 - PCDD / PCDF

Baghouse Outlet

Page 1 of 6

RUN NUMBER	R-M23-O-1	R-M23-O-2	R-M23-O-3		
RUN DATE	8/27/97	8/28/97	8/29/97	Average	
RUN TIME	0940-1516	0746-1229	0809-1236		
<b>MEASURED DATA</b>					
$\gamma$	Meter Box Correction Factor	0.982	0.982	0.982	0.982
$\Delta H$	Avg Meter Orifice Pressure, in. H <sub>2</sub> O	3.04	2.69	2.86	2.87
$P_{bar}$	Barometric Pressure, inches Hg	29.80	29.60	29.60	29.67
$V_m$	Sample Volume, ft <sup>3</sup>	226.829	208.171	226.098	220.366
$T_m$	Average Meter Temperature, °F	111	97	98	102
$P_{static}$	Stack Static Pressure, inches H <sub>2</sub> O	-1.5	-1.4	-1.3	-1.40
$T_s$	Average Stack Temperature, °F	283	287	268	279
$V_{lc}$	Condensate Collected, ml	2083.3	1620.9	1087.4	1597.2
CO <sub>2</sub>	Carbon Dioxide content, % by volume	4.0	4.9	3.0	4.0
O <sub>2</sub>	Oxygen content, % by volume	15.0	13.6	16.3	15.0
N <sub>2</sub>	Nitrogen content, % by volume	81.0	81.5	80.7	81.1
$C_p$	Pitot Tube Coefficient	0.84	0.84	0.84	0.84
$\Delta p^{1/2}$	Average Square Root Dp. (in. H <sub>2</sub> O) <sup>1/2</sup>	1.0260	1.0561	1.0760	1.0527
$\Theta$	Sample Run Duration, minutes	240	240	240	240
$D_n$	Nozzle Diameter, inches	0.256	0.256	0.251	0.254
<b>CALCULATED DATA</b>					
$A_n$	Nozzle Area, ft <sup>2</sup>	0.00036	0.00036	0.00034	0.00035
$V_{m(std)}$	Standard Meter Volume, dscf	206.781	192.849	209.298	202.976
$V_{m(std)}$	Standard Meter Volume, dscm	5.855	5.461	5.927	5.748
$P_s$	Stack Pressure, inches Hg	29.69	29.50	29.50	29.56
$B_{ws}$	Moisture, % by volume	32.2	28.3	19.6	26.7
$B_{ws(sat)}$	Moisture (at saturation), % by volume	359.8	380.0	282.9	340.9
$V_{ws(std)}$	Standard Water Vapor Volume, ft <sup>3</sup>	98.061	76.296	51.184	75.180
$1-B_{ws}$	Dry Mole Fraction	0.678	0.717	0.804	0.733
$M_d$	Molecular Weight (d.b.), lb/lb-mole	29.24	29.33	29.13	29.23
$M_s$	Molecular Weight (w.b.), lb/lb-mole	25.62	26.12	26.94	26.23
$V_s$	Stack Gas Velocity, ft/s	72.8	74.7	74.0	73.8
$A$	Stack Area, ft <sup>2</sup>	11.23	11.23	11.23	11.23
$Q_a$	Stack Gas Volumetric flow, acfm	49,075	50,303	49,832	49,737
$Q_s$	Stack Gas Volumetric flow, dscfm	23,450	25,122	28,612	25,728
$Q_{s(cmm)}$	Stack Gas Volumetric flow, dscmm	664.0	711.4	810.2	728.5
$I$	Isokinetic Sampling Ratio, %	115.5	100.5	99.6	105.2

Summary of Stack Gas Parameters and Test Results  
 US EPA EMC Asphalt Concrete Emissions Testing  
 US EPA Test Method 29 - Multiple Metals  
 Baghouse Outlet  
 Page 1 of 4

RUN NUMBER	R-M29-O-1	R-M29-O-2	R-M29-O-3	Average	
RUN DATE	8/27/97	8/28/97	8/29/97		
RUN TIME	0940-1516	0746-1229	0809-1236		
MEASURED DATA					
$\gamma$	Meter Box Correction Factor	0.965	0.965	0.965	0.965
$\Delta H$	Avg Meter Orifice Pressure, in. H <sub>2</sub> O	2.96	2.14	2.80	2.63
$P_{bar}$	Barometric Pressure, inches Hg	29.80	29.60	29.60	29.67
$V_m$	Sample Volume, ft <sup>3</sup>	237.264	200.329	227.316	221.636
$T_m$	Average Meter Temperature, °F	109	97	100	102
$P_{static}$	Stack Static Pressure, inches H <sub>2</sub> O	-0.42	-0.4	-0.42	-0.41
$T_s$	Average Stack Temperature, °F	289	292	274	285
$V_{lc}$	Condensate Collected, ml	1632.0	1484.6	1147.1	1421.2
CO <sub>2</sub>	Carbon Dioxide content, % by volume	4.0	4.9	3.0	4.0
O <sub>2</sub>	Oxygen content, % by volume	15.0	13.6	16.3	15.0
N <sub>2</sub>	Nitrogen content, % by volume	81.0	81.5	80.7	81.1
$C_p$	Pitot Tube Coefficient	0.84	0.84	0.84	0.84
$\Delta p^{1/2}$	Average Square Root $\Delta p$ , (in. H <sub>2</sub> O) <sup>1/2</sup>	1.0773	1.0386	1.0852	1.0670
$\Theta$	Sample Run Duration, minutes	240	240	240	240
$D_n$	Nozzle Diameter, inches	0.252	0.252	0.252	0.252
CALCULATED DATA					
$A_n$	Nozzle Area, ft <sup>2</sup>	0.000346	0.000346	0.000346	0.000346
$V_{m(std) cf}$	Standard Meter Volume, ft <sup>3</sup>	213.024	182.236	205.914	200.391
$V_{m(std) cm}$	Standard Meter Volume, m <sup>3</sup>	6.032	5.160	5.831	5.674
$Q_m$	Average Sampling Rate, dscfm	0.888	0.759	0.858	0.835
$P_s$	Stack Pressure, inches Hg	29.77	29.57	29.57	29.64
$B_{ws}$	Moisture, % by volume	26.5	27.7	20.8	25.0
$B_{ws(sat)}$	Moisture (at saturation), % by volume	393.7	411.7	310.4	371.9
$V_{wstd}$	Standard Water Vapor Volume, ft <sup>3</sup>	76.818	69.880	53.994	66.897
$1-B_{ws}$	Dry Mole Fraction	0.735	0.723	0.792	0.750
$M_d$	Molecular Weight (d.b.), lb/lb-mole	29.24	29.33	29.13	29.23
$M_s$	Molecular Weight (w.b.), lb/lb-mole	26.26	26.19	26.82	26.42
$V_s$	Stack Gas Velocity, ft/s	75.7	73.5	75.0	74.7
$A$	Stack Area, ft <sup>2</sup>	11.23	11.23	11.23	11.23
$Q_g$	Stack Gas Volumetric flow, acfm	51.035	49.516	50.521	50.357
$Q_s cfm$	Stack Gas Volumetric flow, dscfm	26.285	24.833	28.440	26.520
$Q_s cmm$	Stack Gas Volumetric flow, dscm/m	744	703	805	751
$I$	Isokinetic Sampling Ratio, %	109.5	99.2	97.8	102.2

BAG  
OUT

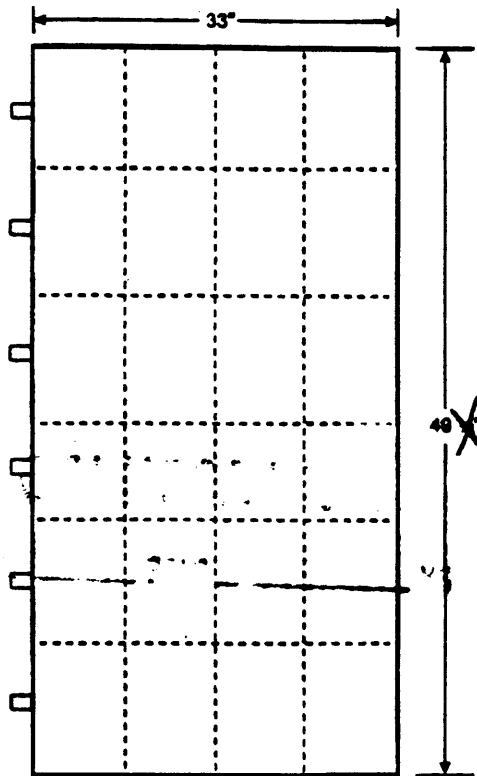

Section B

Traverse Point No.	Distance From Inside Wall, inches
1	4.13
2	12.4
3	20.6
4	28.9

**APPENDIX B**

**FTIR DATA**

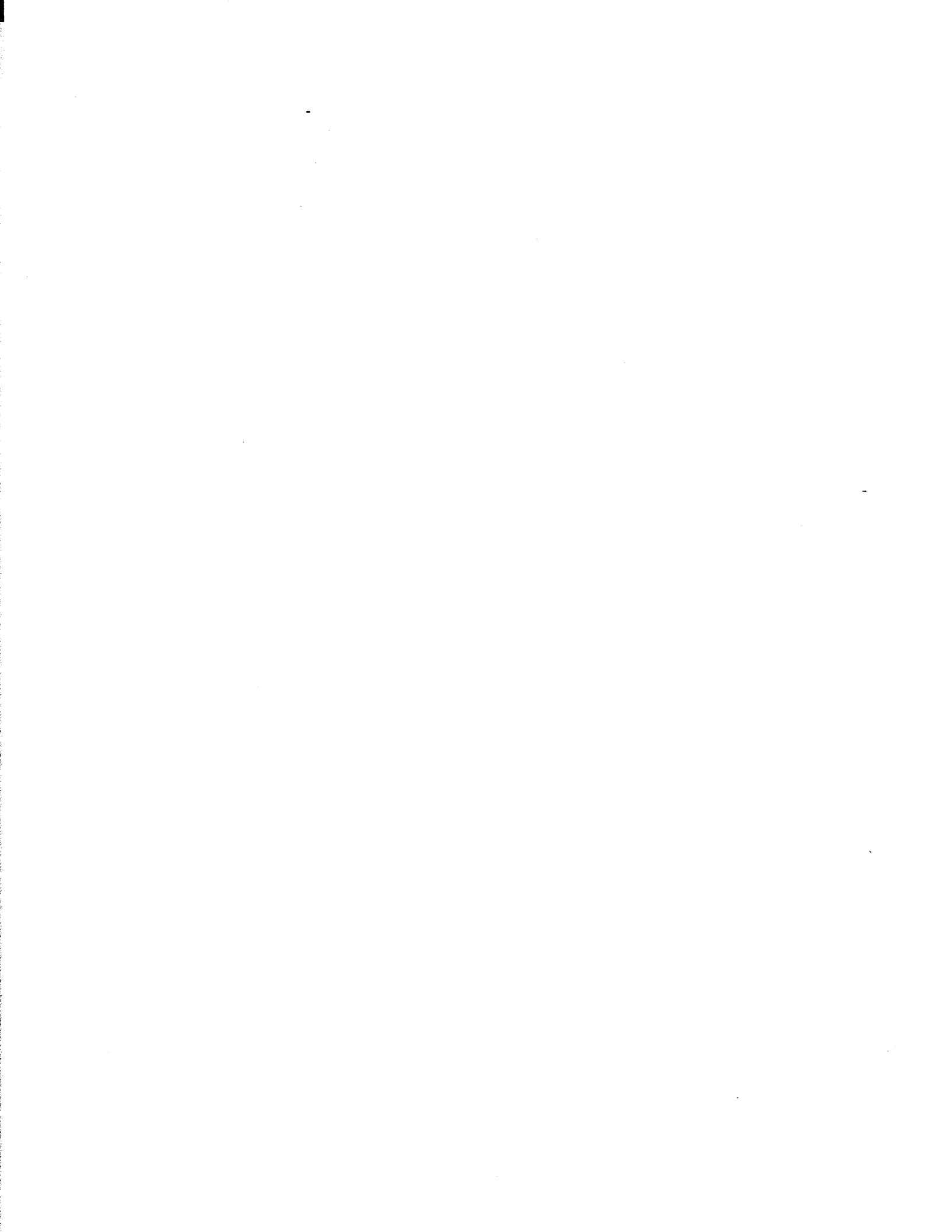



**B-1 FTIR RESULTS**



The semi-continuous FTIR analytical results are presented in Tables B-1 to B-4. Table B-1 presents results from the inlet (wet) samples. Table B-2 presents results from the outlet (wet) samples. Tables B-3 and B-4 present results from dry samples collected at the inlet and outlet, respectively.

Spiked samples are printed in bold type. Some samples were spiked with ethylene during Runs 1 and 3 and with toluene during Run 2. Additionally, some samples during each run were spiked with 3.89 SF<sub>6</sub>. The SF<sub>6</sub>-spiked samples were analyzed to determine the spike dilution ratio for each corresponding set of analyte-spiked samples. The field test documentation identifies the file names with the spiked analyte and the spike flow rate.

Some results measured during process down times are shown in the tables, but these results were not included in the run averages. Results from spiked samples are included in the run averages and the dilution from the spike gas has been accounted for.

The results are reported as ppm concentrations with estimated uncertainties, also in ppm, indicated by the symbol "Δ" in the column heading.

All of the FTIR results are presented graphically following Table B-4.



TABLE B-1. FTIR RESULT OF WET SAMPLES FROM THE BAGHOUSE INLET AT PLANT "B"

Date	Time	File Name	Toluene		Hexane		Ethylene		SF <sub>6</sub>		Methane		Sulfur Dioxide		Carbon Monoxide		Formaldehyde	
			ppm	Δ	ppm	Δ	ppm	Δ	ppm	Δ	ppm	Δ	ppm	Δ	ppm	Δ	ppm	Δ
8/27/97 Run 1	9:52	18270001	0.0	13.6	0.0	68.9	8.3	4.0	0.000	0.113	11.8	4.2	0.0	19.7	36.4	33.5	0.0	6.1
	9:53	18270002	0.0	14.2	0.0	72.0	8.9	4.8	0.000	0.137	12.3	4.3	0.0	23.8	0.0	34.7	0.0	6.4
	9:55	18270003	0.0	14.5	0.0	73.6	10.1	8.9	0.000	0.252	12.4	4.4	0.0	43.9	0.0	35.0	0.0	6.6
	9:57	18270004	0.0	14.6	0.0	74.1	10.4	8.9	0.000	0.251	12.6	4.5	0.0	43.7	0.0	35.3	0.0	6.6
	9:58	18270005	0.0	14.8	0.0	74.9	10.6	8.9	0.000	0.251	12.8	4.5	0.0	43.7	0.0	35.6	0.0	6.7
	10:00	18270006	0.0	14.7	0.0	74.5	10.5	8.9	0.000	0.251	12.7	4.5	0.0	43.8	0.0	35.5	0.0	6.6
	10:02	18270007	0.0	14.7	0.0	74.5	10.5	8.9	0.000	0.251	12.7	4.5	0.0	43.8	43.0	35.6	0.0	6.6
	11:04	<b>REINS103</b>	<b>0.0</b>	<b>7.1</b>	<b>0.0</b>	<b>36.0</b>	<b>23.2</b>	<b>1.8</b>	<b>0.000</b>	<b>0.050</b>	<b>6.0</b>	<b>2.2</b>	<b>20.6</b>	<b>8.7</b>	<b>22.3</b>	<b>18.7</b>	<b>0.0</b>	<b>3.2</b>
	11:10	<b>REINS104</b>	<b>0.0</b>	<b>7.1</b>	<b>0.0</b>	<b>36.1</b>	<b>23.3</b>	<b>1.8</b>	<b>0.000</b>	<b>0.050</b>	<b>6.0</b>	<b>2.2</b>	<b>20.6</b>	<b>8.7</b>	<b>22.5</b>	<b>18.7</b>	<b>0.0</b>	<b>3.2</b>
	11:19	<b>REINS105</b>	<b>0.0</b>	<b>6.9</b>	<b>0.0</b>	<b>34.7</b>	<b>3.5</b>	<b>1.9</b>	<b>0.875</b>	<b>0.048</b>	<b>6.3</b>	<b>2.1</b>	<b>21.2</b>	<b>8.5</b>	<b>29.8</b>	<b>18.2</b>	<b>0.0</b>	<b>3.1</b>
	11:27	<b>REINS106</b>	<b>0.0</b>	<b>6.6</b>	<b>0.0</b>	<b>33.4</b>	<b>3.5</b>	<b>1.9</b>	<b>0.880</b>	<b>0.047</b>	<b>6.1</b>	<b>2.0</b>	<b>22.0</b>	<b>8.2</b>	<b>25.2</b>	<b>17.5</b>	<b>0.0</b>	<b>3.0</b>
	12:20	18270030	0.0	10.7	0.0	54.3	6.1	2.8	0.000	0.077	9.1	3.3	0.0	13.5	0.0	26.7	0.0	4.8
	12:22	18270031	0.0	11.5	0.0	58.2	7.3	3.2	0.000	0.089	9.7	3.5	0.0	15.6	0.0	28.1	0.0	5.2
	12:23	18270032	0.0	11.7	0.0	59.1	7.6	3.3	0.000	0.094	9.7	3.6	0.0	16.4	0.0	28.5	0.0	5.3
	12:25	18270033	0.0	11.6	0.0	59.0	7.7	3.3	0.000	0.094	9.7	3.5	0.0	16.4	0.0	28.5	0.0	5.3
	12:26	18270034	0.0	11.8	0.0	59.9	8.0	3.9	0.000	0.110	9.8	3.6	0.0	19.3	0.0	28.7	0.0	5.3
	12:29	18270035	0.0	11.9	0.0	60.1	8.1	3.6	0.000	0.102	9.8	3.6	0.0	17.8	0.0	28.9	0.0	5.4
	12:31	18270036	0.0	11.9	0.0	60.1	8.0	3.6	0.000	0.102	9.9	3.6	0.0	17.9	0.0	28.8	0.0	5.4
	12:32	18270037	0.0	11.8	0.0	59.9	7.9	3.5	0.000	0.098	9.8	3.6	0.0	17.2	0.0	28.7	0.0	5.3
	12:34	18270038	0.0	11.7	0.0	59.0	7.7	3.4	0.000	0.096	9.7	3.6	0.0	16.7	0.0	28.3	0.0	5.3
	12:36	18270039	0.0	11.5	0.0	58.4	7.6	3.3	0.000	0.092	9.6	3.5	0.0	16.1	0.0	28.1	0.0	5.2
	12:37	18270040	0.0	11.5	0.0	58.1	7.5	3.2	0.000	0.091	9.5	3.5	0.0	15.8	0.0	28.1	0.0	5.2
	12:39	18270041	0.0	11.4	0.0	57.6	7.3	3.2	0.000	0.090	9.3	3.5	0.0	15.6	0.0	27.9	0.0	5.1
	12:41	18270042	0.0	11.3	0.0	57.1	7.1	3.1	0.000	0.089	9.4	3.4	0.0	15.5	0.0	27.6	0.0	5.1
	12:42	18270043	0.0	11.3	0.0	57.1	7.2	3.2	0.000	0.091	9.5	3.4	0.0	15.8	0.0	27.5	0.0	5.1
	12:45	18270044	0.0	11.7	0.0	59.2	7.9	4.2	0.000	0.118	9.7	3.6	0.0	20.6	0.0	28.3	0.0	5.3
	12:47	18270045	0.0	11.7	0.0	59.3	7.9	3.6	0.000	0.102	9.7	3.6	0.0	17.8	0.0	28.4	0.0	5.3
	14:48	18270098	0.0	7.6	0.0	38.6	19.2	2.0	0.000	0.056	12.1	2.3	16.5	9.7	291.8	24.9	4.7	3.4
	14:49	18270099	0.0	7.5	0.0	38.0	18.9	2.0	0.000	0.055	12.0	2.3	16.6	9.6	291.4	24.6	4.6	3.3
	14:52	18270100	0.0	7.4	0.0	37.7	18.6	2.0	0.000	0.054	11.8	2.3	16.8	9.5	291.2	24.5	4.6	3.3
	14:54	18270101	0.0	7.5	0.0	38.0	18.5	2.0	0.000	0.055	11.8	2.3	16.7	9.5	289.3	24.6	4.5	3.3
	14:55	18270102	0.0	7.5	0.0	38.0	18.4	2.0	0.000	0.055	11.9	2.3	16.8	9.6	288.6	24.6	4.4	3.3
	14:57	18270103	0.0	7.5	0.0	37.8	18.7	2.0	0.000	0.054	11.9	2.3	17.4	9.4	290.8	24.5	4.6	3.3
14:59	18270104	0.0	7.4	0.0	37.3	18.9	2.0	0.000	0.054	11.9	2.2	17.4	9.4	292.8	24.3	4.8	3.3	
15:00	18270105	0.0	7.3	0.0	37.1	18.9	2.0	0.000	0.054	11.9	2.2	17.7	9.3	292.9	24.3	4.9	3.2	
15:02	18270106	0.0	7.3	0.0	36.7	19.1	1.9	0.000	0.053	11.9	2.2	18.1	9.2	295.2	24.2	5.1	3.2	
15:04	18270107	0.0	7.2	0.0	36.7	19.4	1.9	0.000	0.053	12.0	2.2	18.3	9.2	297.8	24.2	5.3	3.2	
15:05	18270108	0.0	7.3	0.0	36.7	19.5	1.9	0.000	0.053	12.1	2.2	18.7	9.2	299.0	24.3	5.4	3.2	

TABLE B-1. Continued, Plant "B" Wet Inlet Results

Date	Time	File Name	Toluene		Hexane		Ethylene		SF <sub>6</sub>		Methane		Sulfur Dioxide		Carbon Monoxide		Formaldehyde	
			ppm	Δ	ppm	Δ	ppm	Δ	ppm	Δ	ppm	Δ	ppm	Δ	ppm	Δ	ppm	Δ
8/27/97 Run 1	15:08	18270109	0.0	7.2	0.0	36.3	19.7	1.9	0.000	0.052	12.2	2.2	19.2	9.1	301.5	24.1	5.7	3.2
	15:10	18270110	0.0	7.1	0.0	36.2	19.9	1.9	0.000	0.052	12.3	2.2	19.5	9.1	302.8	24.1	5.8	3.2
	15:11	18270111	0.0	7.1	0.0	35.9	20.2	1.9	0.000	0.052	12.4	2.2	20.3	9.0	305.1	24.0	6.2	3.1
	15:13	18270112	0.0	6.9	0.0	35.1	20.9	1.9	0.000	0.051	12.6	2.1	21.3	8.9	310.4	23.8	6.8	3.1
	15:15	18270113	0.0	6.9	0.0	34.7	20.8	1.8	0.000	0.051	12.4	2.1	22.1	8.8	311.0	23.7	6.9	3.0
	15:16	18270114	0.0	6.8	0.0	34.2	20.8	1.8	0.000	0.050	12.3	2.1	22.6	8.6	312.3	23.4	7.1	3.0
	15:18	18270115	0.0	6.8	0.0	34.2	20.3	1.8	0.000	0.050	12.2	2.1	22.8	8.7	309.6	23.4	7.0	3.0
Average -->			0.0		0.0		12.6		0.000	0.096	11.2		10.9		125.1		2.2	

Date	Time	File Name	Toluene		Hexane		Ethylene		SF <sub>6</sub>		Methane		Sulfur Dioxide		Carbon Monoxide		Formaldehyde	
			ppm	Δ	ppm	Δ	ppm	Δ	ppm	Δ	ppm	Δ	ppm	Δ	ppm	Δ	ppm	Δ
8/28/97 Run 2	8:18	REINS201	43.6	6.9	0.0	49.9	4.0	2.5	0.000	0.068	8.8	3.0	15.1	11.9	0.0	25.0	0.0	4.4
	8:24	REINS202	43.9	7.6	0.0	55.3	4.6	2.7	0.000	0.077	9.8	3.3	0.0	13.5	0.0	27.0	0.0	4.9
	8:34	REINS203	0.0	10.4	0.0	52.6	5.9	2.9	0.868	0.072	8.7	3.2	17.2	12.6	0.0	26.1	0.0	4.7
	8:41	REINS204	0.0	10.8	0.0	54.9	6.1	3.0	0.850	0.077	9.1	3.3	15.9	13.4	0.0	26.8	0.0	4.9
	9:23	18280001	0.0	10.9	0.0	55.1	7.2	2.9	0.000	0.080	10.1	3.3	20.3	13.9	0.0	27.3	0.0	4.9
	9:24	18280002	15.2	8.2	0.0	59.3	7.4	3.3	0.000	0.093	10.7	3.6	0.0	16.1	0.0	28.8	0.0	5.3
	9:26	18280003	16.1	8.4	0.0	61.1	7.9	3.6	0.000	0.101	11.1	3.7	0.0	17.5	0.0	29.4	0.0	5.4
	9:28	18280004	15.6	8.4	0.0	60.8	7.9	3.5	0.000	0.099	10.9	3.7	0.0	17.3	0.0	29.2	0.0	5.4
	9:29	18280005	16.5	8.6	0.0	62.3	8.6	6.4	0.000	0.180	11.1	3.7	0.0	31.4	0.0	29.7	0.0	5.6
	9:32	18280006	17.0	8.7	0.0	63.1	8.9	5.3	0.000	0.151	11.2	3.8	0.0	26.3	0.0	29.9	0.0	5.6
	9:34	18280007	16.8	8.7	0.0	62.9	8.7	4.0	0.000	0.114	11.1	3.8	0.0	19.8	0.0	29.9	0.0	5.6
	9:35	18280008	17.1	8.7	0.0	63.1	8.7	4.0	0.000	0.112	11.0	3.8	0.0	19.5	0.0	29.9	0.0	5.6
	9:37	18280009	16.9	8.8	0.0	63.8	9.0	5.5	0.000	0.154	11.2	3.8	0.0	26.9	0.0	30.2	0.0	5.7
	9:39	18280010	17.2	8.8	0.0	63.6	8.8	4.0	0.000	0.113	11.1	3.8	0.0	19.7	0.0	30.1	0.0	5.7
	9:40	18280011	16.9	8.7	0.0	63.3	8.9	4.5	0.000	0.127	11.1	3.8	0.0	22.1	0.0	29.9	0.0	5.6
	9:42	18280012	16.2	8.7	0.0	62.8	8.7	4.2	0.000	0.119	11.2	3.8	0.0	20.7	0.0	29.6	0.0	5.6
	9:44	18280013	16.8	8.7	0.0	63.3	9.0	6.8	0.000	0.192	11.2	3.8	0.0	33.5	0.0	29.8	0.0	5.6
	9:45	18280014	17.0	8.8	0.0	64.1	10.3	9.0	0.000	0.253	11.4	3.9	0.0	44.1	0.0	30.2	0.0	5.7
	13:18	18280115	0.0	9.4	0.0	47.6	7.3	2.7	0.000	0.075	8.2	2.9	23.0	13.0	32.1	23.7	0.0	4.2
	13:20	18280116	0.0	9.2	0.0	46.7	7.0	2.7	0.000	0.073	8.1	2.8	24.0	12.7	31.0	23.3	0.0	4.2
13:21	18280117	0.0	9.2	0.0	46.6	6.9	2.6	0.000	0.071	8.1	2.8	24.2	12.4	29.3	23.1	0.0	4.1	
13:23	18280118	0.0	9.2	0.0	46.4	6.8	2.6	0.000	0.071	8.1	2.8	24.9	12.4	28.3	23.0	0.0	4.1	
13:25	18280119	0.0	9.2	0.0	46.4	6.9	2.6	0.000	0.070	8.1	2.8	24.7	12.3	32.4	23.1	0.0	4.1	
13:26	18280120	0.0	9.3	0.0	47.0	7.1	2.7	0.000	0.073	8.2	2.8	24.2	12.7	40.6	23.4	0.0	4.2	
13:28	18280121	0.0	9.4	0.0	47.7	7.2	2.7	0.000	0.073	8.3	2.9	23.5	12.7	43.0	23.7	0.0	4.3	
13:29	18280122	0.0	9.4	0.0	47.8	7.3	2.7	0.000	0.074	8.2	2.9	23.2	12.9	39.4	23.7	0.0	4.3	
13:32	18280123	0.0	9.5	0.0	48.1	7.4	2.8	0.000	0.077	8.2	2.9	23.4	13.4	42.5	23.8	0.0	4.3	

TABLE B-1. Continued, Plant "B" Wet Inlet Results

Date	Time	File Name	Toluene		Hexane		Ethylene		SF <sub>6</sub>		Methane		Sulfur Dioxide		Carbon Monoxide		Formaldehyde	
			ppm	Δ	ppm	Δ	ppm	Δ	ppm	Δ	ppm	Δ	ppm	Δ	ppm	Δ	ppm	Δ
8/28/97 Run 2	13:34	18280124	0.0	9.2	0.0	46.7	7.1	2.6	0.000	0.072	8.0	2.8	25.0	12.5	43.9	23.4	0.0	4.2
	13:35	18280125	0.0	9.1	0.0	46.3	7.1	2.6	0.000	0.071	8.0	2.8	25.4	12.3	44.2	23.1	0.0	4.1
	13:37	18280126	0.0	9.2	0.0	46.7	7.2	2.7	0.000	0.072	8.1	2.8	25.1	12.6	39.7	23.2	0.0	4.2
	13:39	18280127	0.0	9.4	0.0	47.6	7.4	2.7	0.000	0.074	8.1	2.9	23.3	12.8	38.7	23.5	0.0	4.2
	13:40	18280128	0.0	9.5	0.0	48.2	7.5	2.8	0.000	0.076	8.2	2.9	22.2	13.2	43.2	23.7	0.0	4.3
	13:42	18280129	0.0	9.6	0.0	48.6	7.7	2.8	0.000	0.076	8.2	2.9	21.2	13.3	39.8	23.9	0.0	4.3
	13:44	18280130	0.0	9.7	0.0	49.3	7.9	3.0	0.000	0.082	8.3	3.0	20.7	14.4	37.0	24.1	0.0	4.4
	13:45	18280131	0.0	9.8	0.0	49.4	7.9	2.9	0.000	0.079	8.4	3.0	19.9	13.7	38.2	24.2	0.0	4.4
Average --->			6.9		0.0		8.0		0.000	0.101	10.2		14.4		18.4		0.0	

Date	Time	File Name	Toluene		Hexane		Ethylene		SF <sub>6</sub>		Methane		Sulfur Dioxide		Carbon Monoxide		Formaldehyde	
			ppm	Δ	ppm	Δ	ppm	Δ	ppm	Δ	ppm	Δ	ppm	Δ	ppm	Δ	ppm	Δ
8/29/97 Run 3	7:59	REINS301	0.0	5.5	0.0	27.9	3.3	1.6	0.762	0.040	5.9	1.6	12.6	6.9	71.5	15.2	0.0	2.5
	8:07	REINS302	5.8	3.9	0.0	28.2	7.1	1.6	0.791	0.040	7.0	1.7	9.7	7.0	147.8	16.9	2.9	2.5
	8:15	REINS303	0.0	5.6	0.0	28.6	6.8	1.6	0.787	0.041	6.9	1.7	8.1	7.1	137.2	16.8	0.0	2.5
	8:28	REINS304	15.7	3.0	0.0	21.0	28.8	1.1	0.000	0.031	8.6	1.3	19.8	5.3	187.3	14.5	5.7	1.9
	8:34	REINS305	7.8	2.9	0.0	20.8	28.2	1.1	0.000	0.030	7.5	1.2	18.0	5.3	172.8	14.0	5.5	1.8
	8:40	REINS306	7.9	2.9	0.0	20.9	28.1	1.1	0.000	0.030	7.4	1.3	17.3	5.3	170.5	14.0	5.3	1.8
	9:27	REINU307	14.9	4.6	0.0	32.8	21.0	1.7	0.000	0.046	13.3	2.0	28.1	8.1	273.3	22.1	10.4	2.9
	9:33	18290001	15.5	4.7	0.0	34.1	20.9	1.8	0.000	0.048	13.5	2.1	27.5	8.4	270.9	23.0	10.2	3.0
	9:34	18290002	15.6	4.8	0.0	34.5	20.9	1.8	0.000	0.048	13.6	2.1	27.1	8.5	270.6	23.2	10.2	3.0
	9:36	18290003	15.8	4.8	0.0	34.3	20.9	1.8	0.000	0.048	13.6	2.1	27.0	8.4	270.7	23.1	10.3	3.0
	9:38	18290004	15.6	4.8	0.0	34.4	20.8	1.8	0.000	0.048	13.5	2.1	26.7	8.4	269.9	23.1	10.2	3.0
	9:39	18290005	15.6	4.8	0.0	34.3	20.8	1.8	0.000	0.048	13.5	2.1	26.8	8.4	270.1	23.1	10.2	3.0
	9:41	18290006	15.6	4.7	0.0	34.1	20.9	1.8	0.000	0.048	13.5	2.1	27.0	8.4	270.6	23.0	10.3	3.0
	9:43	18290007	15.6	4.7	0.0	33.8	20.9	1.7	0.000	0.048	13.5	2.0	26.9	8.3	270.5	22.9	10.3	3.0
	9:44	18290008	15.7	4.7	0.0	33.6	21.0	1.7	0.000	0.047	13.5	2.0	27.2	8.3	272.0	22.8	10.5	3.0
	9:46	18290009	15.7	4.6	0.0	33.4	21.1	1.7	0.000	0.047	13.5	2.0	27.4	8.2	272.8	22.7	10.5	2.9
	9:49	18290010	15.5	4.6	0.0	33.4	21.1	1.7	0.000	0.047	13.5	2.0	27.4	8.2	273.6	22.7	10.6	2.9
	9:50	18290011	15.5	4.6	0.0	33.2	20.9	1.7	0.000	0.047	13.4	2.0	27.6	8.2	273.0	22.6	10.5	2.9
	9:52	18290012	0.0	6.5	0.0	33.1	20.9	1.7	0.000	0.047	13.1	2.0	27.6	8.2	273.2	22.6	9.3	2.9
	9:54	18290013	0.0	6.5	0.0	33.1	21.0	1.7	0.000	0.047	13.1	2.0	27.9	8.2	273.1	22.6	9.3	2.9
9:55	18290014	0.0	6.6	0.0	33.6	21.3	1.7	0.000	0.048	13.8	2.0	27.3	8.3	277.5	23.0	9.1	2.9	
9:57	18290015	0.0	7.2	0.0	36.4	21.1	1.9	0.000	0.051	14.1	2.2	25.2	8.9	284.5	24.5	8.1	3.2	
9:59	18290016	0.0	7.6	0.0	38.5	19.0	2.0	0.000	0.054	13.3	2.3	22.8	9.4	274.1	25.2	6.2	3.4	
10:56	18290039	0.0	10.3	0.0	52.2	6.4	2.7	0.000	0.077	8.7	3.1	0.0	13.5	0.0	25.7	0.0	4.7	
10:58	18290040	0.0	10.2	0.0	51.7	6.4	2.7	0.000	0.077	8.6	3.1	0.0	13.4	0.0	25.4	0.0	4.6	
10:59	18290041	0.0	10.1	0.0	51.3	6.5	2.7	0.000	0.075	8.5	3.1	0.0	13.1	0.0	25.3	0.0	4.6	

B-7

TABLE B-1. Continued, Plant "B" Wet Inlet Results

Date	Time	File Name	Toluene		Hexane		Ethylene		SF <sub>6</sub>		Methane		Sulfur Dioxide		Carbon Monoxide		Formaldehyde	
			ppm	Δ	ppm	Δ	ppm	Δ	ppm	Δ	ppm	Δ	ppm	Δ	ppm	Δ	ppm	Δ
8/29/97 Run 3	11:01	18290042	0.0	10.0	0.0	50.8	6.4	2.6	0.000	0.074	8.2	3.1	0.0	12.9	0.0	25.2	0.0	4.5
	11:03	18290043	0.0	9.8	0.0	49.7	6.2	2.6	0.000	0.073	8.0	3.0	0.0	12.6	26.3	24.8	0.0	4.4
	11:04	18290044	0.0	9.7	0.0	49.3	6.1	2.5	0.000	0.071	8.1	3.0	0.0	12.4	26.5	24.7	0.0	4.4
	11:06	18290045	0.0	9.7	0.0	49.1	6.0	2.5	0.000	0.071	8.1	3.0	0.0	12.4	25.6	24.5	0.0	4.4
	11:09	18290046	0.0	9.6	0.0	48.9	6.0	2.5	0.000	0.071	7.9	2.9	0.0	12.3	0.0	24.3	0.0	4.4
	11:10	18290047	0.0	9.6	0.0	48.9	6.1	2.5	0.000	0.071	7.9	2.9	0.0	12.3	0.0	24.4	0.0	4.4
	11:12	18290048	0.0	9.6	0.0	48.6	6.0	2.5	0.000	0.070	7.8	2.9	0.0	12.2	25.4	24.3	0.0	4.3
	11:14	18290049	0.0	9.6	0.0	48.4	6.0	2.5	0.000	0.071	7.8	2.9	0.0	12.3	0.0	24.4	0.0	4.3
	11:15	18290050	0.0	9.5	0.0	48.1	5.9	2.5	0.000	0.070	7.7	2.9	0.0	12.1	0.0	24.0	0.0	4.3
	11:17	18290051	0.0	9.6	0.0	48.8	6.3	2.5	0.000	0.072	7.7	2.9	0.0	12.5	0.0	24.2	0.0	4.3
	11:19	18290052	0.0	9.7	0.0	49.3	6.4	2.6	0.000	0.073	7.9	3.0	0.0	12.7	0.0	24.5	0.0	4.4
	11:20	18290053	0.0	9.6	0.0	48.8	6.4	2.5	0.000	0.072	7.8	2.9	0.0	12.5	0.0	24.3	0.0	4.3
	14:07	18290132	12.1	4.3	0.0	31.2	19.7	1.7	0.000	0.046	12.0	1.9	27.0	8.1	282.6	21.0	9.2	2.8
	14:09	18290133	12.1	4.3	0.0	31.1	19.8	1.7	0.000	0.046	11.9	1.9	27.5	8.0	282.7	21.0	9.3	2.7
	14:11	18290134	12.0	4.3	0.0	30.8	19.5	1.7	0.000	0.046	11.9	1.9	28.3	8.0	280.4	20.7	9.2	2.7
14:12	18290135	11.9	4.3	0.0	30.5	18.6	1.7	0.000	0.045	11.5	1.8	29.3	7.9	272.4	20.4	8.8	2.7	
14:14	18290136	11.6	4.2	0.0	30.4	17.9	1.6	0.000	0.045	11.2	1.8	29.8	7.9	267.3	20.3	8.4	2.7	
Average -->			6.6		0.0		13.3		0.000	0.058	10.5		16.0		163.5		5.3	



TABLE B-1. Continued, Additional hydrocarbon results in Wet Inlet Samples.

Date	Time	File Name	Heptane		1-Pentene		2-Methyl-2-butene	
			ppm	$\Delta$	ppm	$\Delta$	ppm	$\Delta$
8/27/97 Run 1	9:52	18270001	0.0	29.8	21.2	2.8	0.0	21.8
	9:53	18270002	0.0	31.1	21.2	2.9	0.0	22.8
	9:55	18270003	0.0	31.8	20.9	3.0	0.0	23.3
	9:57	18270004	0.0	32.0	22.0	3.0	0.0	23.5
	9:58	18270005	0.0	32.4	23.1	3.0	0.0	23.7
	10:00	18270006	0.0	32.2	23.8	3.0	0.0	23.6
	10:02	18270007	0.0	32.2	23.9	3.0	0.0	23.6
	11:04	<b>REINS103</b>	<b>0.0</b>	<b>15.5</b>	<b>11.4</b>	<b>1.5</b>	<b>0.0</b>	<b>11.4</b>
	11:10	<b>REINS104</b>	<b>0.0</b>	<b>15.6</b>	<b>10.7</b>	<b>1.5</b>	<b>0.0</b>	<b>11.4</b>
	11:19	<b>REINS105</b>	<b>0.0</b>	<b>15.0</b>	<b>0.0</b>	<b>17.4</b>	<b>0.0</b>	<b>11.0</b>
	11:27	<b>REINS106</b>	<b>0.0</b>	<b>14.4</b>	<b>0.0</b>	<b>16.8</b>	<b>0.0</b>	<b>10.6</b>
	12:20	18270030	9.9	0.8	0.0	5.7	0.0	17.2
	12:22	18270031	9.5	0.9	0.0	6.1	0.0	18.4
	12:23	18270032	9.2	0.9	0.0	6.2	0.0	18.7
	12:25	18270033	8.6	0.9	0.0	6.1	0.0	18.7
	12:26	18270034	7.8	0.9	0.0	6.2	0.0	19.0
	12:29	18270035	8.2	0.9	0.0	6.3	0.0	19.0
	12:31	18270036	8.5	0.9	0.0	6.3	0.0	19.0
	12:32	18270037	8.8	0.9	0.0	6.2	0.0	19.0
	12:34	18270038	8.8	0.9	0.0	6.1	0.0	18.7
	12:36	18270039	8.4	0.9	0.0	6.1	0.0	18.5
	12:37	18270040	7.9	0.9	0.0	6.1	0.0	18.4
	12:39	18270041	8.1	0.9	0.0	6.0	0.0	18.3
	12:41	18270042	8.8	0.9	0.0	5.9	0.0	18.1
	12:42	18270043	9.3	0.9	0.0	5.9	0.0	18.1
	12:45	18270044	8.6	0.9	0.0	6.2	0.0	18.7
12:47	18270045	7.8	0.9	0.0	6.2	0.0	18.8	
14:48	18270098	13.2	0.6	0.0	5.7	0.0	12.2	
8/27/97 Run 1	14:49	18270099	12.0	0.6	0.0	5.6	0.0	12.0
	14:52	18270100	11.3	0.6	0.0	5.6	0.0	11.9
	14:54	18270101	10.9	0.6	0.0	5.6	0.0	12.0
	14:55	18270102	10.8	0.6	0.0	5.6	0.0	12.1
	14:57	18270103	11.1	0.6	0.0	5.6	0.0	12.0
	14:59	18270104	11.4	0.6	0.0	5.5	0.0	11.8
	15:00	18270105	11.3	0.6	0.0	5.5	0.0	11.8
	15:02	18270106	11.3	0.6	0.0	5.4	0.0	11.6
	15:04	18270107	11.3	0.6	0.0	5.4	0.0	11.6
	15:05	18270108	11.2	0.6	0.0	5.4	0.0	11.6
	15:08	18270109	11.4	0.6	0.0	5.4	0.0	11.5
	15:10	18270110	11.7	0.6	0.0	5.4	0.0	11.5

TABLE B-1. Continued, Additional hydrocarbon results in Wet Inlet Samples.

Date	Time	File Name	Heptane		1-Pentene		2-Methyl-2-butene	
			ppm	$\Delta$	ppm	$\Delta$	ppm	$\Delta$
	15:11	18270111	11.9	0.6	0.0	5.3	0.0	11.4
	15:13	18270112	12.3	0.5	0.0	5.2	0.0	11.1
	15:15	18270113	12.4	0.5	0.0	5.1	0.0	11.0
	15:16	18270114	12.6	0.5	0.0	5.8	0.0	3.3
	15:18	18270115	12.5	0.5	0.0	5.8	0.0	3.3
Average --->			7.8		4.3		0.0	

Date	Time	File Name	Heptane		1-Pentene		2-Methyl-2-butene	
			ppm	$\Delta$	ppm	$\Delta$	ppm	$\Delta$
8/28/97	8:18	REINS201	10.1	0.8	0.0	5.2	0.0	15.8
Run 2	8:24	REINS202	10.0	0.9	0.0	5.8	0.0	17.5
	8:34	REINS203	10.4	0.8	0.0	5.5	0.0	16.7
	8:41	REINS204	8.7	0.8	0.0	5.7	0.0	17.4
	9:23	18280001	10.8	0.8	0.0	5.7	0.0	17.5
	9:24	18280002	11.0	0.9	0.0	6.2	0.0	18.8
	9:26	18280003	11.6	1.0	0.0	6.4	0.0	19.3
	9:28	18280004	9.8	1.0	0.0	6.3	0.0	19.3
	9:29	18280005	9.3	1.0	0.0	6.5	0.0	19.7
	9:32	18280006	9.8	1.0	0.0	6.6	0.0	20.0
	9:34	18280007	10.4	1.0	0.0	6.5	0.0	19.9
	9:35	18280008	10.7	1.0	0.0	6.6	0.0	20.0
	9:37	18280009	10.7	1.0	0.0	6.7	0.0	20.2
	9:39	18280010	11.5	1.0	0.0	6.6	0.0	20.2
	9:40	18280011	11.1	1.0	0.0	6.6	0.0	20.1
	9:42	18280012	10.9	1.0	0.0	6.5	0.0	19.9
	9:44	18280013	11.4	1.0	0.0	6.6	0.0	20.1
	9:45	18280014	11.8	1.0	0.0	6.7	0.0	20.3
	13:18	18280115	7.1	0.7	0.0	5.0	0.0	15.1
	13:20	18280116	7.8	0.7	0.0	4.9	0.0	14.8
	13:21	18280117	8.2	0.7	0.0	4.9	0.0	14.7
	13:23	18280118	8.8	0.7	0.0	4.8	0.0	14.7
	13:25	18280119	9.3	0.7	0.0	6.8	0.0	14.7
	13:26	18280120	9.2	0.7	0.0	4.9	0.0	14.9
	13:28	18280121	9.2	0.7	0.0	5.0	0.0	15.1
	13:29	18280122	9.0	0.7	0.0	5.0	0.0	15.1
	13:32	18280123	8.7	0.7	0.0	5.0	0.0	15.2
	13:34	18280124	9.0	0.7	0.0	6.9	0.0	14.8
	13:35	18280125	9.8	0.7	0.0	6.8	0.0	14.7
	13:37	18280126	10.2	0.7	0.0	6.9	0.0	14.8
	13:39	18280127	10.2	0.7	0.0	7.0	0.0	15.1

TABLE B-1. Continued, Additional hydrocarbon results in Wet Inlet Samples.

Date	Time	File Name	Heptane		1-Pentene		2-Methyl-2-butene	
			ppm	$\Delta$	ppm	$\Delta$	ppm	$\Delta$
8/28/97 Run 2	13:40	18280128	9.7	0.7	0.0	7.1	0.0	15.3
	13:42	18280129	9.1	0.8	0.0	7.2	0.0	15.4
	13:44	18280130	8.6	0.8	0.0	5.1	0.0	15.6
	13:45	18280131	9.0	0.8	0.0	7.3	0.0	15.7
Average --->			10.7		0.0		0.0	

Date	Time	File Name	Heptane		1-Pentene		2-Methyl-2-butene	
			ppm	$\Delta$	ppm	$\Delta$	ppm	$\Delta$
8/29/97 Run 3	7:59	REINS301	0.0	12.0	0.0	14.0	0.0	8.8
	8:07	REINS302	0.0	12.2	3.8	1.2	0.0	8.9
	8:15	REINS303	0.0	12.4	2.0	1.1	0.0	9.1
	8:28	REINS304	0.0	9.1	0.0	10.5	0.0	6.6
	8:34	REINS305	6.1	0.3	0.0	10.4	0.0	6.6
	8:40	REINS306	6.3	0.3	0.0	10.5	0.0	6.6
	9:27	REINU307	14.7	0.5	0.0	3.4	0.0	10.4
	9:33	18290001	14.9	0.5	0.0	3.6	0.0	10.8
	9:34	18290002	15.0	0.5	0.0	3.6	0.0	10.9
	9:36	18290003	15.2	0.5	0.0	3.6	0.0	10.9
	9:38	18290004	15.2	0.5	0.0	3.6	0.0	10.9
	9:39	18290005	15.3	0.5	0.0	3.6	0.0	10.9
	9:41	18290006	15.4	0.5	0.0	3.6	0.0	10.8
	9:43	18290007	15.5	0.5	0.0	3.5	0.0	10.7
	9:44	18290008	15.7	0.5	0.0	3.5	0.0	10.6
	9:46	18290009	15.9	0.5	0.0	3.9	0.0	3.4
	9:49	18290010	15.9	0.5	0.0	3.9	0.0	3.4
	9:50	18290011	15.9	0.5	0.0	3.8	0.0	3.4
	9:52	18290012	15.0	1.0	0.0	3.8	4.4	2.8
	9:54	18290013	15.1	1.0	0.0	3.8	4.3	2.8
	9:55	18290014	16.1	0.5	0.0	3.5	0.0	10.7
	9:57	18290015	13.2	0.6	0.0	3.8	0.0	11.5
	9:59	18290016	10.1	0.6	0.0	4.0	0.0	12.2
	10:56	18290039	0.0	22.6	0.0	2.1	0.0	16.5
	10:58	18290040	0.0	22.3	0.0	2.1	0.0	16.4
	10:59	18290041	0.0	22.1	0.0	2.1	0.0	16.2
	11:01	18290042	0.0	21.9	0.0	2.1	0.0	16.1
	11:03	18290043	0.0	21.5	0.0	2.0	0.0	15.7
	11:04	18290044	0.0	21.3	0.0	2.0	0.0	15.6
	11:06	18290045	0.0	21.2	0.0	2.0	0.0	15.6
11:09	18290046	0.0	21.1	0.0	2.0	0.0	15.5	
11:10	18290047	0.0	21.1	0.0	2.0	0.0	15.5	
11:12	18290048	0.0	21.0	0.0	2.0	0.0	15.4	
11:14	18290049	0.0	20.9	0.0	2.0	0.0	15.3	
11:15	18290050	0.0	20.8	0.0	1.9	0.0	15.2	

TABLE B-1. Continued, Additional hydrocarbon results in Wet Inlet Samples.

Date	Time	File Name	Heptane		1-Pentene		2-Methyl-2-butene	
			ppm	$\Delta$	ppm	$\Delta$	ppm	$\Delta$
8/29/97 Run 3	11:17	18290051	0.0	21.1	0.0	2.0	0.0	15.5
	11:19	18290052	0.0	21.3	0.0	2.0	0.0	15.6
	11:20	18290053	0.0	21.1	0.0	2.0	0.0	15.5
	14:07	18290132	4.7	1.3	5.1	3.3	0.0	9.9
	14:09	18290133	4.6	1.2	5.1	3.2	0.0	9.9
	14:11	18290134	4.8	1.2	4.9	3.2	0.0	9.8
	14:12	18290135	5.1	1.2	4.5	3.2	0.0	9.7
	14:14	18290136	5.1	2.7	4.2	14.6	0.0	6.7
Average --->			6.7		0.7		0.2	

TABLE B-2. FTIR RESULTS FROM WET SAMPLES AT THE PLANT "B" BAGHOUSE OUTLET

Date	Time	File Name	Toluene		Hexane		Ethylene		SF <sub>6</sub>		Methane		SO <sub>2</sub>		CO		Formaldehyde	
			ppm	Δ	ppm	Δ	ppm	Δ	ppm	Δ	ppm	Δ	ppm	Δ	ppm	Δ	ppm	Δ
8/27/97 Run 1	10:20	REOUS102	11.5		58.4		6.9	3.2	0.756	0.081	10.5	3.5	16.2	14.2	70.0	29.5		5.2
	10:25	REOUS103	11.3		57.0		6.8	3.1	0.760	0.079	10.2	3.4	15.3	13.7	45.5	28.5		5.1
	10:34	REOUS104	11.3		57.0		23.2	2.8		0.079	9.6	3.4		13.9	30.6	28.2		5.1
	10:40	REOUS105	11.3		57.4		23.5	2.8		0.080	9.6	3.5		14.0	29.2	28.3		5.1
	10:45	REOUS106	10.9		55.1		23.0	2.7		0.077	9.3	3.3		13.4	27.9	27.3		4.9
	11:45	18270011	8.8		44.5		4.7	2.2		0.061	9.0	2.7	14.9	10.6	36.6	23.0		4.0
	11:46	18270012	5.4		27.2		2.0	1.4		0.039	6.2	1.6	15.7	6.8	32.8	14.5		2.4
	11:48	18270013	6.8		34.6		4.7	1.7		0.047	7.7	2.0	18.0	8.3	108.8	19.3		3.1
	11:50	18270014	9.9		50.3		6.3	2.5		0.069	9.0	3.0	15.0	12.1	101.4	26.5		4.5
	11:51	18270015	11.1		56.2		6.4	2.9		0.082	9.6	3.4		14.3	85.5	28.4		5.0
	11:53	18270016	11.4		57.5		6.6	3.0		0.086	9.8	3.5		15.0	72.7	28.9		5.1
	11:54	18270017	11.4		57.6		6.8	3.1		0.086	9.8	3.5		15.0	61.5	28.7		5.1
	11:57	18270018	11.5		58.3		7.0	3.1		0.087	9.8	3.5		15.1	56.5	29.0		5.2
	11:59	18270019	11.5		58.0		6.9	3.1		0.087	9.7	3.5		15.1	60.3	28.9		5.2
	12:00	18270020	11.5		58.0		6.9	3.0		0.086	9.7	3.5		15.0	60.3	28.9		5.2
	12:02	18270021	11.4		57.7		6.9	3.0		0.085	9.7	3.5		14.8	58.2	28.7		5.1
	12:04	18270022	11.6		58.8		7.2	3.1		0.088	9.8	3.5		15.4	57.1	29.0		5.2
	12:05	18270023	11.6		58.7		7.3	3.2		0.089	9.8	3.5		15.6	57.7	29.0		5.2
	12:07	18270024	11.6		58.5		7.3	3.1		0.088	9.7	3.5		15.3	58.8	28.9		5.2
	12:09	18270025	11.4		57.9		7.1	3.1		0.087	9.4	3.5		15.1	60.7	28.7		5.2
	12:10	18270026	11.3		57.0		6.8	3.0		0.084	9.3	3.5		14.7	52.0	28.2		5.1
	12:13	18270027	11.4		57.6		7.0	3.0		0.086	9.4	3.5		14.9	52.2	28.5		5.1
	14:27	18270088	10.2		51.7		7.6	2.9		0.082	8.4	3.1		14.3	114.8	26.7		4.6
	14:29	18270089	10.1		51.2		7.5	2.8		0.079	8.3	3.1		13.8	140.7	26.8		4.6
	14:30	18270090	8.9		45.0		11.9	2.3		0.065	9.9	2.7		11.4	197.2	25.4		4.0
	14:32	18270091	7.6		38.6		17.9	2.0		0.055	11.7	2.3	13.4	9.6	256.1	24.0		3.4
	14:34	18270092	7.2		36.7		19.0	1.9		0.053	12.0	2.2	14.0	9.2	267.9	23.6	5.0	3.2
14:36	18270093	7.2		36.7		19.2	1.9		0.053	12.2	2.2	13.5	9.2	271.4	23.6	5.2	3.2	
14:38	18270094	7.6		38.3		18.8	2.0		0.055	12.2	2.3	13.4	9.6	278.4	24.5	4.5	3.3	
14:40	18270095	7.5		37.9		19.1	2.0		0.055	12.3	2.3	15.5	9.5	288.0	24.6	4.8	3.3	
14:41	18270096	7.4		37.5		19.3	2.0		0.054	12.4	2.3	17.8	9.4	291.8	24.5	5.0	3.3	
14:43	18270097	7.4		37.3		19.2	2.0		0.054	12.3	2.2	18.9	9.3	292.2	24.4	5.1	3.3	
Average -->							10.7		0.072	11.4		6.5		125.6		1.0		

TABLE B-2. Continued. FTIR RESULTS OF WET OUTLET SAMPLES

Date	Time	File Name	Toluene		Hexane		Ethylene		SF <sub>6</sub>		Methane		SO <sub>2</sub>		CO		Formaldehyde	
			ppm	Δ	ppm	Δ	ppm	Δ	ppm	Δ	ppm	Δ	ppm	Δ	ppm	Δ	ppm	Δ
8/28/97 Run 2	7:32	REOUS201		7.6		38.7	5.8	2.1	0.835	0.053	7.0	2.3	24.2	9.2	78.0	20.8		3.4
	7:40	REOUS202		7.7		39.1	4.3	2.1	0.704	0.053	8.3	2.3	22.1	9.3	33.1	20.0		3.5
	7:50	REOUS203		10.1		51.3	5.8	2.8	0.822	0.070	8.7	3.1	20.5	12.2	46.5	26.1		4.6
	8:00	REOUS204	42.9	7.4		53.5	5.3	2.7		0.074	9.6	3.2	14.0	12.9	36.6	26.8		4.8
	8:05	REOUS205	43.4	8.0		58.1	5.7	2.9		0.082	10.4	3.5		14.2	30.8	28.4		5.2
	9:54	18280016		12.0		60.8	7.5	3.6	0.098		11.1	3.7	38.5	17.2		29.0		5.4
	9:55	18280017		11.8		59.7	8.0	3.4	0.093		10.8	3.6	20.3	16.2		28.6		5.3
	9:57	18280018		11.8		59.6	7.2	3.3	0.092		10.8	3.6		16.1		28.5		5.3
	9:59	18280019		11.7		59.3	7.2	3.3	0.093		10.7	3.6		16.2		28.5		5.3
	10:00	18280020		11.6		58.7	7.9	3.3	0.090		10.6	3.5	17.9	15.7		28.3		5.2
	10:02	18280021		11.7		59.1	8.0	3.4	0.093		10.6	3.6	17.7	16.2		28.4		5.3
	10:05	18280022		11.9		60.3	7.6	3.4	0.096		10.8	3.6		16.7		28.9		5.4
	10:06	18280023		11.9		60.5	7.7	3.6	0.102		10.8	3.6		17.8		28.9		5.4
	10:08	18280024		11.8		59.9	7.5	3.4	0.096		10.7	3.6		16.7		28.7		5.3
	10:10	18280025		11.8		59.7	7.5	3.3	0.094		10.4	3.6		16.4		28.6		5.3
	10:11	18280026		11.7		59.4	7.3	3.2	0.091		10.4	3.6		15.9		28.5		5.3
	10:13	18280027		11.7		59.2	7.4	3.2	0.091		10.3	3.6		15.9		28.4		5.3
	10:15	18280028		11.7		59.3	7.5	3.4	0.095		10.5	3.6		16.6		28.4		5.3
	10:16	18280029		11.7		59.5	7.6	3.5	0.099		10.6	3.6		17.3		28.5		5.3
	10:18	18280030		11.7		59.4	7.5	3.4	0.097		10.5	3.6		16.9		28.5		5.3
	10:21	18280031		11.7		59.5	7.5	3.3	0.094		10.2	3.6		16.4		28.6		5.3
	10:22	18280032	16.1	8.2		59.9	7.7	3.6	0.100		10.2	3.6		17.5		28.7		5.3
	10:24	18280033	16.0	8.3		60.2	7.9	3.8	0.106		10.2	3.6		18.5		28.6		5.4
	10:26	18280034		11.8		59.5	7.7	3.7	0.104		10.3	3.6		18.1		28.5		5.3
	10:27	18280035		11.7		59.1	7.5	3.6	0.101		10.2	3.6		17.6		28.4		5.3
	12:41	18280096		8.2		41.8	6.4	2.2	0.060		7.5	2.5	23.0	10.5	94.3	22.2		3.7
	12:44	18280097		8.5		42.9	6.7	2.3	0.062		7.8	2.6	22.9	10.9	97.0	22.7		3.8
	12:45	18280098		8.5		43.2	6.9	2.3	0.063		7.9	2.6	23.0	10.9	96.8	22.9		3.8
	12:47	18280099		8.7		43.9	7.5	2.3	0.064		8.3	2.6	20.9	11.2	117.3	23.4		3.9
	12:49	18280100		8.8		44.4	8.0	2.4	0.065		8.5	2.7	19.9	11.3	126.7	23.8		4.0
	12:50	18280101		8.7		44.1	8.1	2.4	0.064		8.5	2.7	20.1	11.2	134.3	23.8		3.9
	12:52	18280102		8.7		43.9	8.2	2.4	0.065		8.6	2.7	20.6	11.3	137.8	23.8		3.9
	12:54	18280103		8.7		44.1	8.1	2.4	0.064		8.5	2.7	20.2	11.2	134.3	23.8		3.9
	12:55	18280104		8.8		44.8	7.4	2.4	0.065		8.2	2.7	19.5	11.3	109.3	23.6		4.0
	12:57	18280105		9.0		45.4	7.5	2.5	0.067		8.3	2.7	18.3	11.7	105.2	23.7		4.0
	13:00	18280106		8.8		44.7	7.6	2.4	0.066		8.2	2.7	18.5	11.6	112.9	23.6		4.0
	13:01	18280107		8.8		44.4	7.7	2.4	0.066		8.3	2.7	18.6	11.5	116.7	23.6		4.0
	13:03	18280108		8.7		44.1	7.8	2.4	0.065		8.2	2.7	19.0	11.3	119.7	23.5		3.9
	13:05	18280109		8.8		44.7	7.2	2.4	0.066		8.1	2.7	20.0	11.6	90.0	23.2		4.0
	13:06	18280110		8.9		45.0	6.7	2.4	0.066		7.9	2.7	21.0	11.5	66.5	23.0		4.0
	13:08	18280111		9.0		45.7	6.7	2.5	0.067		7.9	2.8	20.8	11.7	55.3	23.1		4.1
	13:10	18280112		9.2		46.6	6.8	2.5	0.069		7.9	2.8	21.2	12.0	32.9	23.2		4.1
	13:53	18280134		9.0		45.6	6.9	2.5	0.068		7.8	2.7	21.5	11.8	38.3	22.7		4.1
	13:54	18280135		8.9		45.0	7.0	2.5	0.068		7.8	2.7	21.8	11.8	38.0	22.5		4.0

TABLE B-2. Continued. FTIR RESULTS OF WET OUTLET SAMPLES

Date	Time	File Name	Toluene		Hexane		Ethylene		SF <sub>6</sub>		Methane		SO <sub>2</sub>		CO		Formaldehyde	
			ppm	Δ	ppm	Δ	ppm	Δ	ppm	Δ	ppm	Δ	ppm	Δ	ppm	Δ	ppm	Δ
8/28/97 Run 2	13:56	18280136		7.5		37.7	5.4	2.0		0.055	6.8	2.3	37.2	9.5	41.8	19.7		3.4
	13:58	18280137		5.5		28.0	3.9	1.5		0.042	6.2	1.7	44.5	7.4	46.9	15.3		2.5
	13:59	18280138		4.4		22.3	2.7	1.3		0.035	5.9	1.4	36.9	6.1	43.1	12.2		2.0
	14:01	18280139		3.4		17.4	1.8	1.0		0.028	5.2	1.1	27.4	4.9	33.1	9.6		1.6
	14:04	18280140		3.0		15.4	1.4	0.9		0.025	4.9	1.0	23.0	4.4	28.5	8.4		1.4
	14:05	18280141		2.4		12.0	1.0	0.7		0.020	4.2	0.8	16.7	3.5	30.7	6.8		1.1
	14:09	18280142		8.8		44.8	7.1	2.5		0.068	8.0	2.7	21.7	11.9	105.8	23.3		4.0
	14:11	18280143		9.2		46.4	7.4	2.7		0.073	8.2	2.8	20.3	12.6	86.1	23.6		4.1
	14:12	18280144		9.7		48.9	7.4	2.8		0.077	8.4	3.0	19.6	13.4	84.8	24.7		4.4
	14:14	18280145		9.7		49.3	7.6	2.9		0.079	8.5	3.0	19.5	13.7	86.3	24.8		4.4
	14:16	18280146		9.1		46.0	7.3	2.6		0.072	8.0	2.8	21.0	12.5	74.1	23.2		4.1
	14:17	18280147		9.0		45.7	7.3	2.6		0.070	7.9	2.8	21.6	12.2	63.5	23.0		4.1
	14:20	18280148		9.0		45.5	7.3	2.6		0.071	7.9	2.7	21.7	12.4	61.5	23.0		4.1
	14:22	18280149		9.1		46.0	7.4	2.6		0.071	8.0	2.8	21.0	12.5	61.0	23.1		4.1
	14:23	18280150		9.2		46.4	7.6	2.7		0.073	8.0	2.8	20.2	12.8	63.7	23.2		4.1
	14:25	18280151		9.3		47.2	7.7	2.7		0.075	8.1	2.9	20.0	13.1	72.7	23.7		4.2
	14:27	18280152		9.2		46.8	7.6	2.7		0.074	8.1	2.8	20.0	12.8	73.4	23.5		4.2
14:28	18280153		9.3		46.9	7.6	2.7		0.073	8.0	2.8	19.9	12.8	66.7	23.4		4.2	
14:30	18280154		9.3		47.1	7.6	2.7		0.074	8.1	2.8	20.0	13.0	69.6	23.6		4.2	
Average -->			0.6			7.6			0.075	9.6		15.7		56.1				

B-15

Date	Time	File Name	Toluene		Hexane		Ethylene		SF <sub>6</sub>		Methane		SO <sub>2</sub>		CO		Formaldehyde	
			ppm	Δ	ppm	Δ	ppm	Δ	ppm	Δ	ppm	Δ	ppm	Δ	ppm	Δ	ppm	Δ
8/29/97 Run 3	8:48	REOUS301	12.7	4.1	29.4	35.2	1.5		0.042	11.2	1.8	23.5	7.3	242.4	19.8	8.8	2.6	
	8:54	REOUS302	13.0	4.2	30.2	35.2	1.6		0.043	11.4	1.8	23.7	7.5	241.7	20.2	8.6	2.7	
	9:01	REOUS303	13.2	4.0	28.8	35.4	1.5		0.041	11.3	1.7	24.7	7.2	243.9	19.6	8.9	2.5	
	9:08	REOUS304	12.9	4.0	29.2	17.9	1.7	0.784	0.042	11.3	1.8	24.5	7.3	243.4	19.7	8.6	2.6	
	9:14	REOUS305	12.7	4.1	29.5	17.6	1.7	0.798	0.042	11.1	1.8	25.4	7.3	242.9	19.8	8.4	2.6	
	9:21	REOUS306	12.5	4.0	29.1	17.6	1.6	0.797	0.042	11.1	1.7	26.4	7.3	243.0	19.7	8.4	2.6	
	10:05	18290018		8.0	40.6	9.1	2.1		0.057	9.3	2.4	19.2	9.9	186.3	24.0		3.6	
	10:07	18290019		7.9	40.1	9.0	2.1		0.056	9.1	2.4	19.5	9.8	185.8	23.8		3.6	
	10:09	18290020		7.8	39.5	9.2	2.0		0.055	9.1	2.4	20.6	9.6	191.5	23.6		3.5	
	10:10	18290021		7.5	37.9	9.8	1.9		0.053	9.2	2.3	23.1	9.3	203.4	23.2		3.4	
	10:12	18290022		7.3	37.2	10.0	1.9		0.053	9.1	2.2	24.9	9.2	207.4	22.9		3.3	
	10:14	18290023		7.3	37.2	10.0	1.9		0.052	9.2	2.2	25.1	9.1	206.6	22.9		3.3	
	10:15	18290024		7.4	37.2	12.8	1.9		0.052	10.7	2.2	24.9	9.1	229.8	23.5		3.3	
	10:17	18290025		7.4	37.5	14.4	1.9		0.053	11.0	2.3	24.9	9.2	242.7	23.8	3.5	3.3	
	10:20	18290026		7.9	40.0	12.9	2.0		0.056	10.7	2.4	21.4	9.7	222.7	24.5		3.5	
	10:21	18290027		8.9	44.9	9.0	2.3		0.062	9.3	2.7	13.5	10.9	147.0	25.0		4.0	
	10:23	18290028		9.7	49.1	7.0	2.5		0.069	8.8	2.9		12.1	74.3	25.4		4.4	
10:25	18290029		10.2	51.4	6.7	2.6		0.073	8.6	3.1		12.8	35.1	25.7		4.6		
10:26	18290030		10.1	51.4	6.4	2.6		0.074	8.5	3.1		12.9		25.5		4.6		
10:28	18290031		10.1	51.3	6.3	2.6		0.074	8.4	3.1		12.9		25.4		4.6		
10:30	18290032		10.0	50.9	6.2	2.6		0.074	8.3	3.1		12.8		25.3		4.5		
10:31	18290033		10.1	51.1	6.2	2.6		0.074	8.3	3.1		12.9		25.3		4.6		
10:33	18290034		10.2	51.6	6.2	2.6		0.075	8.4	3.1		13.0		25.5		4.6		

TABLE B-2. Continued. FTIR RESULTS OF WET OUTLET SAMPLES

Date	Time	File Name	Toluene		Hexane		Ethylene		SF <sub>6</sub>		Methane		SO <sub>2</sub>		CO		Formaldehyde		
			ppm	Δ	ppm	Δ	ppm	Δ	ppm	Δ	ppm	Δ	ppm	Δ	ppm	Δ	ppm	Δ	
8/29/97	10:36	18290035		10.3		52.2	6.5	2.7		0.075	8.4	3.1		13.2		25.7		4.6	
	10:37	18290036		10.4		52.6	6.4	2.7		0.076	8.5	3.2		13.3		26.0		4.7	
	10:39	18290037		10.0		50.5	6.2	2.6		0.073	8.2	3.0		12.6		25.1		4.5	
	10:40	18290038		9.9		50.1	6.2	2.6		0.072	8.1	3.0		12.6		24.9		4.5	
	10:45	REOUU307		9.9		50.2	6.3	2.6		0.073	8.1	3.0		12.8		24.5		4.5	
8/29/97	12:47	18290095		3.4		17.4	7.2	1.1		0.029	6.6	1.1		18.2	5.0	146.8	11.5	1.6	1.5
	12:49	18290096		2.9		14.5	4.8	0.9		0.024	5.4	0.9		15.2	4.2	110.8	9.3		1.3
	12:50	18290097		2.5		12.8	3.7	0.8		0.022	4.8	0.8		13.4	3.8	90.9	8.2		1.1
	12:52	18290098		2.2		11.3	2.7	0.7		0.020	4.3	0.7		11.2	3.4	73.7	7.2		1.0
	12:54	18290099		2.0		10.3	2.2	0.7		0.018	4.0	0.7		10.0	3.2	62.3	6.6		0.9
	12:55	18290100		2.0		10.1	2.1	0.7		0.018	3.9	0.6		9.6	3.1	59.0	6.5		0.9
	12:57	18290101		2.0		10.0	2.0	0.7		0.018	3.9	0.6		9.5	3.1	57.7	6.5		0.9
	13:00	18290102		2.0		10.3	2.1	0.7		0.018	4.0	0.7		9.8	3.2	60.1	6.6		0.9
	13:01	18290103		2.0		10.1	2.1	0.7		0.018	4.0	0.7		9.8	3.1	58.0	6.5		0.9
	13:03	18290104		2.0		9.9	1.9	0.6		0.018	3.9	0.6		9.4	3.1	56.1	6.4		0.9
	13:05	18290105		1.9		9.7	1.9	0.6		0.017	3.9	0.6		9.4	3.0	54.2	6.2		0.9
	13:06	18290106		1.9		9.5	1.7	0.6		0.017	3.8	0.6		9.2	3.0	51.6	6.1		0.8
	13:08	18290107		1.9		9.4	1.8	0.6		0.017	3.8	0.6		9.3	3.0	52.1	6.1		0.8
	13:10	18290108		1.8		9.0	1.6	0.6		0.016	3.6	0.6		8.8	2.9	47.9	5.8		0.8
	13:11	18290109		1.6		8.3	1.3	0.6		0.016	3.4	0.5		8.0	2.7	40.2	5.5		0.7
	13:13	18290110		1.6		7.9	1.2	0.5		0.015	3.3	0.5		7.7	2.6	36.8	5.3		0.7
	13:16	18290111		1.6		7.9	1.2	0.5		0.015	3.3	0.5		7.7	2.6	36.9	5.3		0.7
	13:29	18290112		12.4	4.6	32.7	14.6	1.8		0.048	10.2	2.0		19.6	8.4	239.7	20.7	5.0	2.9
	13:32	18290113		11.8	4.4	31.6	14.3	1.7		0.047	10.0	1.9		19.6	8.1	233.2	20.1	5.3	2.8
	13:33	18290114		11.8	4.4	31.8	14.7	1.7		0.047	10.1	1.9		19.1	8.2	235.7	20.3	5.7	2.8
	13:35	18290115		11.9	4.4	31.8	14.8	1.7		0.047	10.2	1.9		19.0	8.2	237.7	20.2	5.8	2.8
	13:37	18290116		11.7	4.3	31.1	15.0	1.7		0.046	10.3	1.9		20.2	8.0	240.8	20.0	6.2	2.7
	13:38	18290117		11.9	4.3	30.7	15.1	1.7		0.046	10.2	1.8		21.0	7.9	241.5	19.8	6.4	2.7
	13:40	18290118		11.9	4.3	30.9	14.9	1.7		0.046	10.2	1.9		20.7	8.0	239.3	19.9	6.1	2.7
	13:42	18290119		11.8	4.4	31.4	14.8	1.7		0.046	10.2	1.9		19.7	8.1	237.4	20.1	5.8	2.8
	13:43	18290120		11.7	4.4	31.5	14.6	1.7		0.046	10.1	1.9		18.7	8.1	236.2	20.1	5.7	2.8
	13:45	18290121		11.9	4.4	31.4	15.4	1.7		0.046	10.4	1.9		19.0	8.1	242.4	20.2	6.2	2.8
13:48	18290122		12.1	4.3	31.2	16.2	1.7		0.046	10.7	1.9		19.3	8.0	247.8	20.2	6.8	2.8	
13:49	18290123		12.1	4.4	31.5	16.2	1.7		0.046	10.7	1.9		19.5	8.1	247.3	20.3	6.7	2.8	
13:51	18290124		12.0	4.4	31.3	16.2	1.7		0.046	10.7	1.9		19.2	8.1	247.3	20.2	6.6	2.8	
13:53	18290125		12.0	4.4	31.4	16.1	1.7		0.046	10.6	1.9		18.6	8.1	246.3	20.3	6.5	2.8	
13:54	18290126		11.8	4.4	31.3	16.0	1.7		0.047	10.6	1.9		18.6	8.1	246.9	20.2	6.5	2.8	
13:56	18290127		11.9	4.4	31.4	16.0	1.7		0.046	10.7	1.9		18.7	8.1	246.7	20.2	6.4	2.8	
13:58	18290128		12.4	4.3	31.0	17.3	1.7		0.046	11.2	1.9		19.0	8.0	259.6	20.3	7.4	2.7	
13:59	18290129		12.9	4.2	30.5	18.6	1.7		0.045	11.8	1.8		21.2	7.9	273.4	20.4	8.4	2.7	
Average --->			7.5			13.9			0.045	10.8			17.7		194.7		4.5		



TABLE B-2. Continued. Additional Hydrocarbon Results in Wet Samples From the Plant B Outlet.

Date	Time	File Name	Heptane		1-Pentene		2-Methyl-2-butene	
			ppm	$\Delta$	ppm	$\Delta$	ppm	$\Delta$
8/27/97	10:20	REOUS102		25.2	18.1	2.3		18.5
Run 1	10:25	REOUS103		24.6	19.0	2.2		18.1
	10:34	REOUS104		24.6	17.2	2.3		18.1
	10:40	REOUS105		24.8	13.9	2.3		18.2
	10:45	REOUS106		23.8	15.6	2.2		17.4
	11:45	18270011	22.4	0.7		7.6		4.8
	11:46	18270012	18.4	0.4		13.6		2.4
	11:48	18270013	15.0	0.5		5.8		3.4
	11:50	18270014	11.9	0.8		5.2		15.9
	11:51	18270015	10.0	0.9		5.8		17.8
	11:53	18270016	9.8	0.9		6.0		18.2
	11:54	18270017	9.8	0.9		6.0		18.3
	11:57	18270018	9.6	0.9		6.1		18.5
	11:59	18270019	9.6	0.9		6.0		18.4
	12:00	18270020	9.1	0.9		6.0		18.4
	12:02	18270021	8.5	0.9		6.0		18.3
	12:04	18270022	8.3	0.9		6.1		18.6
	12:05	18270023	8.3	0.9		6.1		18.6
	12:07	18270024	8.3	0.9		6.1		18.5
	12:09	18270025		25.0	18.5	2.4		18.3
	12:10	18270026		24.6	18.5	2.3		18.1
	12:13	18270027		24.9	18.5	2.3		18.2
	14:27	18270088	7.2	0.8		7.6		16.4
	14:29	18270089	7.5	0.8		7.6		16.2
	14:30	18270090	10.7	0.7		6.6		14.2
	14:32	18270091	14.7	0.6		5.7		12.2
	14:34	18270092	15.6	0.6		6.2		3.6
	14:36	18270093	15.4	0.6		3.8		3.7
8/27/97	14:38	18270094	13.6	0.6		6.5		3.7
Run 1	14:40	18270095	13.1	0.6		6.4		3.7
	14:41	18270096	13.6	0.6		3.9		3.8
	14:43	18270097	13.9	0.6		3.9		3.8
Average ---->			8.1		6.9			

TABLE B-2. Continued. Additional Hydrocarbon Results in Wet Outlet Samples

Date	Time	File Name	Heptane		1-Pentene		2-Methyl-2-butene	
			ppm	$\Delta$	ppm	$\Delta$	ppm	$\Delta$
8/28/97 Run 2	7:32	REOUS201	8.5	0.6		4.0		12.2
	7:40	REOUS202	19.5	0.6		5.7		4.1
	7:50	REOUS203	10.7	0.8		5.3		16.3
	8:00	REOUS204	11.1	0.8		5.6		17.0
	8:05	REOUS205	10.5	0.9		6.0		18.4
	9:54	18280016	13.2	0.9		6.3		19.3
	9:55	18280017	13.2	0.9		6.2		18.9
	9:57	18280018	13.2	0.9		6.2		18.9
	9:59	18280019	12.5	0.9		6.2		18.8
	10:00	18280020	10.7	0.9		6.1		18.6
	10:02	18280021	10.8	0.9		6.2		18.7
	10:05	18280022	10.9	0.9		6.3		19.1
	10:06	18280023	11.1	0.9		6.3		19.2
	10:08	18280024	11.0	0.9		6.2		19.0
	10:10	18280025	10.0	0.9		6.2		18.9
	10:11	18280026	9.3	0.9		6.2		18.8
	10:13	18280027	9.7	0.9		6.2		18.7
	10:15	18280028	10.3	0.9		6.2		18.8
	10:16	18280029	10.5	0.9		6.2		18.9
	10:18	18280030	8.3	0.9		6.2		18.8
	10:21	18280031		25.7	18.9	2.4		18.8
	10:22	18280032		25.9	17.2	2.5		19.0
	10:24	18280033		26.0	16.6	2.5		19.1
	10:26	18280034		25.7	18.7	2.4		18.9
8/28/97 Run 2	10:27	18280035		25.5	19.2	2.4		18.7
	12:41	18280096		18.0	10.7	1.7		13.2
	12:44	18280097		18.6	11.7	1.7		13.6
	12:45	18280098		18.6	12.3	1.7		13.7
	12:47	18280099		19.0	11.1	1.8		13.9
	12:49	18280100		19.2	10.6	1.8		14.1
	12:50	18280101		19.1	11.2	1.8		14.0
	12:52	18280102		19.0	12.2	1.8		13.9
	12:54	18280103		19.1	11.8	1.8		14.0
	12:55	18280104		19.3	9.8	1.8		14.2
	12:57	18280105		19.6	8.7	1.8		14.4
	13:00	18280106		19.3	8.4	1.8		14.2
	13:01	18280107		19.2	9.2	1.8		14.1
	13:03	18280108		19.1	9.0	1.8		14.0
	13:05	18280109		19.3	9.8	1.8		14.2

TABLE B-2. Continued. Additional Hydrocarbon Results in Wet Outlet Samples

Date	Time	File Name	Heptane		1-Pentene		2-Methyl-2-butene		
			ppm	$\Delta$	ppm	$\Delta$	ppm	$\Delta$	
8/28/97	13:06	18280110		19.4	10.9	1.8		14.3	
	13:08	18280111		19.7	11.8	1.9		14.5	
	13:10	18280112		20.1	11.5	1.9		14.7	
	13:53	18280134	7.8	0.7		6.7		14.4	
	13:54	18280135	7.3	0.7		6.7		14.3	
	13:56	18280136	8.3	0.6		5.6		12.0	
	13:58	18280137	14.1	0.4		3.4		2.9	
	13:59	18280138	26.4	0.3		5.0		2.0	
	14:01	18280139	27.0	0.3		8.8		1.6	
	14:04	18280140	28.6	0.2		7.7		1.5	
	14:05	18280141	18.3	0.2		6.0		1.1	
	14:09	18280142	9.6	0.7		4.7		14.2	
	14:11	18280143	7.8	0.7		6.9		14.7	
	14:12	18280144	7.1	0.8		5.1		15.5	
	14:14	18280145	7.0	0.8		5.1		15.6	
	Run 2	14:16	18280146	7.5	0.7		6.8		14.6
		14:17	18280147	7.9	0.7		6.8		14.5
		14:20	18280148	8.1	0.7		6.7		14.4
		14:22	18280149	7.9	0.7		6.8		14.6
		14:23	18280150	7.5	0.7		4.8		14.7
		14:25	18280151	7.3	0.7		7.0		15.0
		14:27	18280152	7.2	0.7		6.9		14.8
		14:28	18280153	6.9	0.7		6.9		14.9
		14:30	18280154	6.7	0.7		7.0		14.9
	Average --->			6.8		4.8			

Date	Time	File Name	Heptane		1-Pentene		2-Methyl-2-butene		
			ppm	$\Delta$	ppm	$\Delta$	ppm	$\Delta$	
8/29/97	8:48	REOUS301	11.1	0.5		3.1		9.3	
	Run 3	8:54	REOUS302	11.4	0.5		3.1		9.6
		9:01	REOUS303	12.1	0.5		3.0		9.1
		9:08	REOUS304	12.0	0.5		3.0		9.2
		9:14	REOUS305	11.8	0.5		3.1		9.3
		9:21	REOUS306	12.1	0.5		3.0		9.2
8/29/97	10:05	18290018		17.5	6.0	1.6		12.9	
	10:07	18290019		17.3	4.7	1.6		12.7	
	10:09	18290020		17.0	4.4	1.6		12.5	
	10:10	18290021		16.4	4.8	1.5		12.0	
	Run 3	10:12	18290022		16.1	5.1	1.5		11.8
		10:14	18290023		16.1	5.1	1.5		11.8
		10:15	18290024		16.1	7.7	1.4		11.8

TABLE B-2. Continued. Additional Hydrocarbon Results in Wet Outlet Samples

Date	Time	File Name	Heptane		1-Pentene		2-Methyl-2-butene	
			ppm	$\Delta$	ppm	$\Delta$	ppm	$\Delta$
8/29/97 Run 3	10:17	18290025		16.2	10.4	1.5		11.9
	10:20	18290026		17.3	8.5	1.6		12.7
	10:21	18290027		19.4	3.3	1.8		14.2
	10:23	18290028		21.2		2.0		15.6
	10:25	18290029		22.2		2.1		16.3
	10:26	18290030		22.2		2.1		16.3
	10:28	18290031		22.2		2.1		16.2
	10:30	18290032		22.0		2.1		16.1
	10:31	18290033		22.1		2.1		16.2
	10:33	18290034		22.3		2.1		16.3
	10:36	18290035		22.5		2.1		16.5
	10:37	18290036		22.7		2.1		16.6
	10:39	18290037		21.8		2.0		16.0
	10:40	18290038		21.7		2.0		15.9
	10:45	REOUU307		21.7		2.0		15.9
	12:47	18290095	17.7	0.3		8.8		1.5
	12:49	18290096	18.5	0.2		7.3		1.3
	12:50	18290097	18.2	0.2		6.4		1.2
	12:52	18290098	15.6	0.2		5.7		1.0
	12:54	18290099	13.6	0.2		5.2		0.9
12:55	18290100	13.4	0.2		5.0		0.9	
12:57	18290101	13.3	0.2		5.0		0.9	
13:00	18290102	14.7	0.2		5.2		1.0	
13:01	18290103	14.7	0.2		5.1		0.9	
13:03	18290104	14.3	0.2		5.0		0.9	
13:05	18290105	13.7	0.2		4.9		0.9	
13:06	18290106	13.0	0.1		4.8		1.0	
8/29/97 Run 3	13:08	18290107	13.2	0.1		4.7		0.9
	13:10	18290108	11.9	0.1		4.5		0.9
	13:11	18290109	9.1	0.1		4.2		0.8
	13:13	18290110	7.8	0.1		4.0		0.8
	13:16	18290111	7.8	0.1		4.0		0.8
	13:29	18290112	4.1	1.3	4.6	3.4		10.4
	13:32	18290113	4.1	1.3	4.2	3.3		10.0
8/29/97 Run 3	13:33	18290114	4.1	1.3	4.3	3.3		10.1
	13:35	18290115	4.3	1.3	4.2	3.3		10.1
	13:37	18290116	4.6	1.2	4.0	3.2		9.9
	13:38	18290117	5.0	1.2	3.9	3.2		9.7
	13:40	18290118	4.9	1.2	3.9	3.2		9.8
	13:42	18290119	4.6	1.3	4.0	3.3		9.9
	13:43	18290120	4.4	1.3	4.0	3.3		10.0
	13:45	18290121	4.3	1.3	4.2	3.3		9.9

TABLE B-2. Continued. Additional Hydrocarbon Results in Wet Outlet Samples

Date	Time	File Name	Heptane		1-Pentene		2-Methyl-2-butene	
			ppm	$\Delta$	ppm	$\Delta$	ppm	$\Delta$
8/29/97 Run 3	13:48	18290122	4.6	1.3	4.2	3.3		9.9
	13:49	18290123	4.6	1.3	4.2	3.3		10.0
	13:51	18290124	4.5	1.3	4.2	3.3		9.9
	13:53	18290125	4.4	1.3	4.2	3.3		10.0
	13:54	18290126	4.2	1.3	4.3	3.3		9.9
	13:56	18290127	4.2	1.3	4.2	3.3		9.9
	13:58	18290128	4.6	1.2	4.4	3.2		9.8
	13:59	18290129	5.0	1.2	4.6	3.2		9.7
Average --->			4.4		2.9			

TABLE B-3. FTIR RESULTS OF DRY SAMPLES FROM THE PLANT B BAGHOUSE INLET

Date	Time	File Name	Toluene		Hexane		Ethylene		Methane		SO <sub>2</sub>		CO		Formaldehyde	
			ppm	Δ	ppm	Δ	ppm	Δ	ppm	Δ	ppm	Δ	ppm	Δ	ppm	Δ
8/27/97 Run 1	13:33	18270064	0.0	2.7	0.0	13.5	1.4	0.7	1.9	0.8	19.7	3.5	80.3	9.9	0.0	1.2
	13:34	18270065	0.0	2.8	0.0	14.2	1.5	0.8	1.9	0.9	20.3	3.6	70.5	10.0	0.0	1.3
	13:36	18270066	0.0	2.8	0.0	14.3	1.5	0.8	1.8	0.9	20.2	3.7	62.6	9.9	0.0	1.3
	13:38	18270067	0.0	3.0	0.0	15.0	1.6	0.8	1.9	0.9	19.9	3.8	60.5	10.2	0.0	1.3
	13:39	18270068	0.0	3.1	0.0	15.5	1.7	0.8	1.9	0.9	18.9	3.9	63.7	10.5	0.0	1.4
	13:41	18270069	0.0	3.1	0.0	15.9	1.8	0.8	1.9	1.0	18.2	4.0	65.9	10.7	0.0	1.4
	13:43	18270070	0.0	3.2	0.0	16.2	1.8	0.9	1.9	1.0	18.1	4.1	65.6	10.8	0.0	1.4
	13:44	18270071	0.0	3.2	0.0	16.2	1.8	0.9	1.9	1.0	18.3	4.1	63.6	10.7	0.0	1.4
	13:48	18270073	0.0	3.2	0.0	16.1	1.8	0.9	1.9	1.0	18.4	4.1	58.0	10.6	0.0	1.4
	13:50	18270074	0.0	3.1	0.0	15.9	1.8	0.8	1.8	1.0	18.3	4.0	56.6	10.4	0.0	1.4
	13:52	18270075	0.0	3.1	0.0	15.9	1.9	0.8	1.9	1.0	18.4	4.0	57.1	10.5	0.0	1.4
	13:53	18270076	0.0	3.1	0.0	15.9	1.9	0.9	1.8	1.0	18.2	4.0	57.6	10.5	0.0	1.4
	13:55	18270077	0.0	3.2	0.0	16.0	1.8	0.9	1.9	1.0	18.1	4.1	59.4	10.5	0.0	1.4
	13:57	18270078	0.0	3.1	0.0	15.9	1.9	0.9	1.9	1.0	18.2	4.0	59.5	10.5	0.0	1.4
	13:58	18270079	0.0	3.1	0.0	15.9	1.9	0.9	1.9	1.0	18.3	4.0	57.5	10.5	0.0	1.4
	14:00	18270080	0.0	3.2	0.0	16.0	1.9	0.9	1.9	1.0	18.5	4.1	57.6	10.5	0.0	1.4
Average --->			0.0		0.0		1.7		1.9		18.8		62.3		0.0	

B-22

Date	Time	File Name	Toluene		Hexane		Ethylene		Methane		SO <sub>2</sub>		CO		Formaldehyde	
			ppm	Δ	ppm	Δ	ppm	Δ	ppm	Δ	ppm	Δ	ppm	Δ	ppm	Δ
8/28/97 Run 2	10:42	REINU205	0.0	3.0	0.0	15.4	1.6	0.8	2.8	0.9	28.7	3.8	49.5	10.3	0.0	1.4
	10:46	18280036	0.0	3.3	0.0	16.7	1.7	0.9	2.8	1.0	28.0	4.1	53.0	11.1	0.0	1.5
	10:47	18280037	0.0	3.3	0.0	16.8	1.8	0.9	2.8	1.0	28.1	4.2	51.3	11.1	0.0	1.5
	10:49	18280038	0.0	3.4	0.0	17.2	1.8	0.9	2.8	1.0	27.9	4.2	52.1	11.2	0.0	1.5

TABLE B-3. Continued. Baghouse Inlet Dry Sample Results.

Date	Time	File Name	Toluene		Hexane		Ethylene		Methane		SO <sub>2</sub>		CO		Formaldehyde	
			ppm	Δ	ppm	Δ	ppm	Δ	ppm	Δ	ppm	Δ	ppm	Δ	ppm	Δ
8/28/97 Run 2	10:52	18280039	0.0	3.4	0.0	17.4	1.8	0.9	2.8	1.1	27.5	4.3	53.6	11.3	0.0	1.5
	10:53	18280040	0.0	3.5	0.0	17.6	1.8	0.9	2.7	1.1	27.5	4.3	56.3	11.5	0.0	1.6
	10:55	18280041	0.0	3.5	0.0	17.5	1.9	0.9	2.7	1.1	27.4	4.3	60.8	11.5	0.0	1.6
	10:57	18280042	0.0	3.5	0.0	17.6	1.9	0.9	2.7	1.1	27.7	4.3	62.3	11.5	0.0	1.6
	10:58	18280043	0.0	3.5	0.0	17.6	2.0	0.9	2.8	1.1	26.5	4.3	59.8	11.4	0.0	1.6
	11:00	18280044	0.0	3.5	0.0	17.9	2.0	0.9	2.7	1.1	26.1	4.4	48.4	11.3	0.0	1.6
	11:02	18280045	0.0	3.6	0.0	18.3	1.9	0.9	2.8	1.1	25.7	4.5	39.3	11.4	0.0	1.6
	11:03	18280046	0.0	3.7	0.0	18.5	1.9	1.0	2.7	1.1	25.4	4.5	34.2	11.3	0.0	1.6
	11:05	18280047	0.0	3.7	0.0	18.6	2.0	1.0	2.5	1.1	25.3	4.6	31.4	11.3	0.0	1.7
	11:08	18280048	0.0	3.7	0.0	18.7	2.0	1.0	2.5	1.1	25.3	4.6	30.7	11.4	0.0	1.7
	11:09	18280049	0.0	3.7	0.0	18.8	1.9	1.0	2.5	1.1	25.2	4.6	30.4	11.4	0.0	1.7
	11:11	18280050	0.0	3.7	0.0	18.8	2.0	1.0	2.6	1.1	25.1	4.6	30.5	11.4	0.0	1.7
	12:02	18280076	0.0	3.5	0.0	17.6	1.9	0.9	2.2	1.1	23.6	4.4	60.0	11.2	0.0	1.6
	12:03	18280077	0.0	2.8	0.0	14.4	1.6	0.8	2.2	0.9	25.2	3.7	64.1	10.0	0.0	1.3
	12:05	18280078	0.0	2.7	0.0	13.7	1.5	0.7	2.2	0.8	25.7	3.5	63.4	9.6	0.0	1.2
	12:07	18280079	0.0	2.7	0.0	13.5	1.4	0.7	2.2	0.8	25.9	3.5	61.5	9.5	0.0	1.2
	12:08	18280080	0.0	2.7	0.0	13.8	1.5	0.7	2.1	0.8	26.0	3.5	59.7	9.6	0.0	1.2
	12:10	18280081	0.0	2.8	0.0	14.2	1.5	0.8	2.1	0.9	25.9	3.6	59.5	9.7	0.0	1.3
	12:13	18280082	0.0	2.9	0.0	14.7	1.6	0.8	2.1	0.9	26.0	3.7	61.5	10.0	0.0	1.3
	12:14	18280083	0.0	2.8	0.0	14.4	1.6	0.8	2.1	0.9	26.0	3.7	61.6	9.8	0.0	1.3
	12:16	18280084	0.0	2.8	0.0	14.3	1.6	0.8	2.1	0.9	26.1	3.6	58.2	9.7	0.0	1.3
	12:18	18280085	0.0	2.8	0.0	14.0	1.6	0.7	2.1	0.8	26.4	3.6	59.5	9.5	0.0	1.2
	12:19	18280086	0.0	2.8	0.0	14.0	1.6	0.8	2.0	0.8	26.8	3.6	62.3	9.6	0.0	1.2
	12:21	18280087	0.0	2.8	0.0	14.0	1.6	0.7	2.1	0.8	27.0	3.6	69.0	9.6	0.0	1.2
	12:23	18280088	0.0	2.8	0.0	14.0	1.7	0.7	2.1	0.8	26.2	3.6	74.0	9.7	0.0	1.2
	12:24	18280089	0.0	2.8	0.0	14.3	1.7	0.8	2.1	0.9	25.8	3.6	73.5	9.8	0.0	1.3
12:26	18280090	0.0	2.8	0.0	14.4	1.8	0.8	2.1	0.9	25.5	3.6	75.0	9.8	0.0	1.3	

TABLE B-3. Continued. Baghouse Inlet Dry Sample Results.

Date	Time	File Name	Toluene		Hexane		Ethylene		Methane		SO <sub>2</sub>		CO		Formaldehyde	
			ppm	Δ	ppm	Δ	ppm	Δ	ppm	Δ	ppm	Δ	ppm	Δ	ppm	Δ
8/28/97	12:29	18280091	0.0	2.9	0.0	14.5	1.8	0.8	2.1	0.9	25.6	3.7	78.4	9.9	0.0	1.3
Run 2	12:30	18280092	0.0	2.9	0.0	14.5	1.9	0.8	2.2	0.9	25.7	3.7	84.9	10.0	0.0	1.3
	12:32	18280093	0.0	2.9	0.0	14.5	1.9	0.8	2.2	0.9	25.7	3.7	92.4	10.2	0.0	1.3
Average --->			0.0		0.0		1.8		2.4		26.3		57.7		0.0	

Date	Time	File Name	Toluene		Hexane		Ethylene		Methane		SO <sub>2</sub>		CO		Formaldehyde	
			ppm	Δ	ppm	Δ	ppm	Δ	ppm	Δ	ppm	Δ	ppm	Δ	ppm	Δ
8/29/97	12:07	18290075	0.0	2.5	0.0	12.8	1.4	0.7	2.2	0.8	11.4	3.3	40.0	8.3	0.0	1.1
Run 3	12:09	18290076	0.0	2.5	0.0	12.7	1.4	0.7	2.2	0.8	11.4	3.3	40.0	8.2	0.0	1.1
	12:10	18290077	0.0	2.5	0.0	12.7	1.3	0.7	2.2	0.8	11.4	3.3	40.1	8.2	0.0	1.1
	12:13	18290078	0.0	2.5	0.0	12.7	1.3	0.7	2.1	0.8	11.4	3.3	40.1	8.3	0.0	1.1
	12:15	18290079	0.0	2.5	0.0	12.6	1.2	0.7	2.0	0.8	11.3	3.3	40.3	8.2	0.0	1.1
	12:16	18290080	0.0	2.5	0.0	12.7	1.2	0.7	2.0	0.8	11.1	3.3	40.1	8.3	1.4	1.1
	12:18	18290081	0.0	2.5	0.0	12.7	1.1	0.7	2.0	0.8	11.1	3.3	40.1	8.3	2.0	1.1
	12:20	18290082	0.0	2.5	0.0	12.7	1.1	0.7	2.0	0.8	11.0	3.3	40.3	8.3	2.7	1.1
	12:21	18290083	0.0	2.5	0.0	12.6	1.1	0.7	2.0	0.8	10.7	3.3	40.3	8.2	3.3	1.1
	12:23	18290084	0.0	2.5	0.0	12.6	1.1	0.7	2.0	0.8	10.5	3.3	40.5	8.2	3.9	1.1
	12:25	18290085	0.0	2.5	0.0	12.6	1.0	0.7	2.0	0.8	10.5	3.3	40.4	8.3	4.6	1.1
	12:26	18290086	0.0	2.5	0.0	12.6	1.0	0.7	2.0	0.8	10.6	3.2	40.7	8.2	5.2	1.1
	12:29	18290087	0.0	2.5	0.0	12.6	0.9	0.7	2.0	0.8	10.5	3.2	40.6	8.2	5.7	1.1
	12:30	18290088	0.0	2.5	0.0	12.5	0.9	0.7	2.0	0.8	10.3	3.2	40.7	8.2	6.2	1.1
	12:32	18290089	0.0	2.5	0.0	12.5	0.9	0.7	2.0	0.8	10.2	3.2	40.8	8.2	6.8	1.1
	12:34	18290090	0.0	2.4	0.0	12.4	0.8	0.7	2.0	0.8	10.0	3.2	40.9	8.1	7.4	1.1
	12:35	18290091	0.0	2.5	0.0	12.5	0.8	0.7	2.0	0.8	10.1	3.2	40.8	8.2	7.9	1.1
12:37	18290092	0.0	2.5	0.0	12.6	0.7	0.7	2.0	0.8	9.8	3.2	40.8	8.2	8.4	1.1	
12:39	18290093	0.0	2.5	0.0	12.6	0.7	0.7	2.0	0.8	9.8	3.2	40.9	8.2	9.0	1.1	
Average --->			0.0		0.0		1.0		2.0		10.7		40.4		3.9	



TABLE B-3. Continued. Additional Hydrocarbon Results.

Date	Time	File Name	3-Methylpentane		Isooctane		Heptane		1-Pentene		2-Methyl-2-butene		n-Pentane	
			ppm	$\Delta$	ppm	$\Delta$	ppm	$\Delta$	ppm	$\Delta$	ppm	$\Delta$	ppm	$\Delta$
8/27/97	13:33	18270064	0.0	0.6	0.0	0.9	7.9	0.2	0.0	2.3	0.0	1.3	0.0	13.3
Run 1	13:34	18270065	0.0	0.6	0.0	1.0	8.1	0.2	0.0	2.4	0.0	1.4	0.0	13.9
	13:36	18270066	0.0	1.2	0.0	1.0	8.4	0.2	0.0	3.1	0.0	1.5	0.0	2.7
	13:38	18270067	0.0	1.3	0.0	1.0	8.6	0.2	0.0	3.2	0.0	1.5	0.0	2.8
	13:39	18270068	0.0	1.3	0.0	1.0	8.6	0.2	0.0	3.3	0.0	1.6	0.0	2.9
	13:41	18270069	0.0	1.4	0.0	1.1	8.4	0.2	0.0	3.4	0.0	1.6	0.0	3.0
	13:43	18270070	0.0	1.1	0.0	1.1	8.1	0.3	0.0	2.7	0.0	1.6	0.0	15.9
	13:44	18270071	0.0	1.1	0.0	1.1	8.1	0.3	0.0	2.7	0.0	1.6	0.0	15.8
	13:48	18270073	0.0	1.4	0.0	1.1	8.3	0.3	0.0	3.4	0.0	1.6	0.0	3.0
	13:50	18270074	0.0	1.4	0.0	1.1	8.2	0.2	0.0	3.4	0.0	1.6	0.0	3.0
	13:52	18270075	0.0	1.4	0.0	1.1	8.0	0.2	0.0	3.4	0.0	1.6	0.0	3.0
	13:53	18270076	0.0	1.4	0.0	1.1	7.9	0.2	0.0	3.4	0.0	1.6	0.0	3.0
	13:55	18270077	0.0	1.4	0.0	1.1	8.0	0.2	0.0	3.4	0.0	1.6	0.0	3.0
	13:57	18270078	0.0	1.4	0.0	1.1	8.1	0.2	0.0	3.4	0.0	1.6	0.0	3.0
	13:58	18270079	0.0	1.4	0.0	1.1	8.2	0.2	0.0	3.4	0.0	1.6	0.0	3.0
	14:00	18270080	0.0	1.4	0.0	1.1	8.2	0.3	0.0	3.4	0.0	1.6	0.0	3.0
	Average ---->			0.0		0.0		8.2		0.0		0.0		0.0

TABLE B-3. Continued. Additional Hydrocarbon Results.

Date	Time	File Name	3-Methylpentane		Isooctane		Heptane		1-Pentene		2-Methyl-2-butene		n-Pentane		
			ppm	$\Delta$	ppm	$\Delta$	ppm	$\Delta$	ppm	$\Delta$	ppm	$\Delta$	ppm	$\Delta$	
8/28/97 Run 2	10:42	REINU205	0.0	1.3	0.8	0.4	10.4	0.4	0.0	2.3	0.0	1.3	0.0	3.8	
	10:46	18280036	0.0	1.4	0.8	0.4	10.7	0.5	0.0	2.5	0.0	1.5	0.0	4.1	
	10:47	18280037	0.0	1.4	0.8	0.4	10.4	0.5	0.0	2.5	0.0	1.8	0.0	4.1	
	10:49	18280038	0.0	1.5	0.7	0.4	10.6	0.5	0.0	2.5	0.0	1.8	0.0	4.2	
	10:52	18280039	0.0	1.5	0.7	0.4	10.3	0.5	0.0	2.1	0.0	1.9	0.0	4.3	
	10:53	18280040	0.0	1.5	0.7	0.4	9.7	0.5	0.0	2.1	0.0	1.9	0.0	4.3	
	10:55	18280041	0.0	1.5	0.7	0.4	9.6	0.5	0.0	2.1	0.0	1.9	0.0	4.3	
	10:57	18280042	0.0	1.5	0.7	0.4	9.6	0.5	0.0	2.1	0.0	1.9	0.0	4.3	
	10:58	18280043	0.0	1.5	0.7	0.4	9.6	0.5	0.0	2.1	0.0	1.9	0.0	4.3	
	11:00	18280044	0.0	1.5	0.7	0.4	9.5	0.5	0.0	2.2	0.0	1.9	0.0	4.4	
	8/28/97 Run 2	11:02	18280045	0.0	1.6	0.8	0.4	9.1	0.5	0.0	2.2	0.0	2.0	0.0	4.5
		11:03	18280046	0.0	1.6	0.7	0.4	8.6	0.5	0.0	2.2	0.0	2.0	0.0	4.5
		11:05	18280047	0.0	1.6	0.0	1.3	7.8	0.7	2.4	1.9	0.0	1.9	0.0	3.4
		11:08	18280048	0.0	1.6	0.0	1.3	7.4	0.7	2.5	1.9	0.0	5.9	0.0	3.4
11:09		18280049	0.0	1.2	0.0	1.3	8.1	0.3	0.0	2.8	0.0	5.9	0.0	18.4	
11:11		18280050	0.0	1.2	0.0	1.3	7.9	0.3	0.0	2.8	0.0	5.9	0.0	18.4	
12:02		18280076	0.0	1.1	0.0	1.2	7.7	0.7	2.4	1.8	0.0	1.7	0.0	17.3	
12:03		18280077	0.0	1.1	0.7	0.3	7.1	0.4	0.0	2.5	0.0	1.5	0.0	14.1	
12:05		18280078	0.0	1.1	0.7	0.3	7.0	0.4	0.0	2.3	0.0	1.5	0.0	13.4	
12:07		18280079	0.0	1.1	0.7	0.3	6.7	0.4	0.0	2.3	0.0	1.5	0.0	13.3	
12:08		18280080	0.0	0.9	0.0	0.9	7.1	0.2	0.0	2.3	0.0	1.4	0.0	13.5	
12:10		18280081	0.0	0.9	0.0	1.0	7.2	0.2	0.0	2.4	0.0	1.4	0.0	13.9	
12:13		18280082	0.0	1.0	0.0	1.0	7.2	0.2	0.0	2.5	0.0	1.4	0.0	14.4	
12:14		18280083	0.0	0.9	0.0	1.0	7.3	0.2	0.0	2.4	0.0	1.4	0.0	14.1	
12:16	18280084	0.0	0.9	0.0	1.0	7.2	0.2	0.0	2.4	0.0	1.4	0.0	14.0		
12:18	18280085	0.0	0.9	0.0	0.9	6.8	0.2	0.0	2.4	0.0	1.4	0.0	13.7		
12:19	18280086	0.0	0.9	0.0	0.9	6.8	0.2	0.0	2.4	0.0	1.4	0.0	13.7		

TABLE B-3. Continued. Additional Hydrocarbon Results.

Date	Time	File Name	3-Methylpentane		Isooctane		Heptane		1-Pentene		2-Methyl-2-butene		n-Pentane	
			ppm	$\Delta$	ppm	$\Delta$	ppm	$\Delta$	ppm	$\Delta$	ppm	$\Delta$	ppm	$\Delta$
8/28/97 Run 2	12:21	18280087	0.0	0.9	0.0	0.9	6.7	0.2	0.0	2.4	0.0	1.4	0.0	13.7
	12:23	18280088	0.0	0.9	0.0	0.9	6.7	0.2	0.0	2.4	0.0	1.4	0.0	13.7
	12:24	18280089	0.0	0.9	0.0	1.0	6.7	0.2	0.0	2.4	0.0	1.4	0.0	14.0
	12:26	18280090	0.0	0.9	0.0	1.0	6.8	0.2	0.0	2.4	0.0	1.4	0.0	14.1
	12:29	18280091	0.0	0.9	0.0	1.0	6.9	0.2	0.0	2.4	0.0	1.4	0.0	14.2
	12:30	18280092	0.0	0.9	0.0	1.0	7.3	0.2	0.0	2.4	0.0	1.4	0.0	14.2
	12:32	18280093	0.0	0.9	0.0	1.0	7.5	0.2	0.0	2.4	0.0	1.4	0.0	14.2
Average ---->			0.0		0.3		8.1		0.2		0.0		0.0	

B-27

Date	Time	File Name	3-Methylpentane		Isooctane		Heptane		1-Pentene		2-Methyl-2-butene		n-Pentane	
			ppm	$\Delta$	ppm	$\Delta$	ppm	$\Delta$	ppm	$\Delta$	ppm	$\Delta$	ppm	$\Delta$
8/29/97 Run 3	12:07	18290075	3.7	0.2	0.0	0.9	0.0	5.5	0.0	2.2	0.0	1.2	0.0	12.5
	12:09	18290076	3.9	0.2	0.0	0.9	0.0	5.5	0.0	2.2	0.0	1.2	0.0	12.4
	12:10	18290077	4.0	0.2	0.0	0.9	0.0	5.5	0.0	2.2	0.0	1.2	0.0	12.4
	12:13	18290078	4.1	0.2	0.0	0.9	0.0	5.5	0.0	2.2	0.0	1.2	0.0	12.4
8/29/97 Run 3	12:15	18290079	3.9	0.4	0.0	0.9	0.0	5.5	0.0	2.2	1.2	0.9	0.0	12.4
	12:16	18290080	0.0	1.0	0.0	0.9	0.0	5.5	0.0	2.5	0.0	1.2	5.1	0.2
	12:18	18290081	0.0	1.0	0.0	0.9	0.0	5.5	0.0	2.5	0.0	1.2	5.3	0.2
	12:20	18290082	0.0	1.1	0.0	0.9	0.0	5.5	0.0	2.6	0.0	1.2	5.4	0.3
	12:21	18290083	0.0	1.0	0.0	0.9	0.0	5.4	0.0	2.5	0.0	1.2	5.6	0.2
	12:23	18290084	0.0	1.0	0.0	0.8	0.0	5.4	0.0	2.5	0.0	1.2	5.7	0.2
	12:25	18290085	0.0	1.0	0.0	0.9	0.0	5.5	0.0	2.5	0.0	1.2	5.9	0.2
	12:26	18290086	0.0	1.0	0.0	0.8	0.0	5.4	0.0	2.5	0.0	1.2	6.0	0.2
12:29	18290087	0.0	1.0	0.0	0.8	0.0	5.4	0.0	2.5	0.0	1.2	6.1	0.2	

TABLE B-3. Continued. Additional Hydrocarbon Results.

Date	Time	File Name	3-Methylpentane		Isooctane		Heptane		1-Pentene		2-Methyl-2-butene		n-Pentane	
			ppm	$\Delta$	ppm	$\Delta$	ppm	$\Delta$	ppm	$\Delta$	ppm	$\Delta$	ppm	$\Delta$
	12:30	18290088	0.0	1.0	0.0	0.8	0.0	5.4	0.0	2.5	0.0	1.2	6.3	0.2
	12:32	18290089	0.0	1.0	0.0	0.8	0.0	5.4	0.0	2.5	0.0	1.0	6.4	0.2
	12:34	18290090	0.0	1.0	0.0	0.8	0.0	5.4	0.0	2.5	0.0	1.0	6.6	0.2
	12:35	18290091	0.0	1.0	0.0	0.8	0.0	5.4	0.0	2.5	0.0	1.0	6.7	0.2
	12:37	18290092	0.0	1.0	0.0	0.9	0.0	5.4	0.0	2.5	0.0	1.0	6.9	0.2
	12:39	18290093	0.0	1.0	0.0	0.8	0.0	5.4	0.0	2.5	0.0	1.0	7.0	0.2
Average --->			1.0		0.0		0.0		0.0		0.1		4.5	

TABLE B-4. FTIR RESULTS OF DRY SAMPLES FROM THE PLANT B BAGHOUSE OUTLET

Date	Time	File Name	Toluene		Hexane		Ethylene		Methane		Sulfur Dioxide		Carbon Monoxide		Formaldehyde	
			ppm	Δ	ppm	Δ	ppm	Δ	ppm	Δ	ppm	Δ	ppm	Δ	ppm	Δ
8/27/97 Run 1	12:58	18270047	0.0	2.7	0.0	13.5	1.2	0.7	2.0	0.8	18.5	3.5	45.5	9.3	0.0	1.2
	13:01	18270048	0.0	2.7	0.0	13.5	1.2	0.7	2.0	0.8	18.6	3.5	46.0	9.4	0.0	1.2
	13:02	18270049	0.0	2.7	0.0	13.6	1.2	0.7	2.1	0.8	18.4	3.5	45.5	9.3	0.0	1.2
	13:04	18270050	0.0	2.7	0.0	13.5	1.2	0.7	2.0	0.8	18.1	3.5	43.9	9.3	0.0	1.2
	13:06	18270051	0.0	2.7	0.0	13.6	1.2	0.7	2.0	0.8	18.3	3.5	42.6	9.3	0.0	1.2
	13:07	18270052	0.0	2.7	0.0	13.8	1.2	0.7	1.9	0.8	18.3	3.5	41.6	9.3	0.0	1.2
	13:09	18270053	0.0	2.8	0.0	14.0	1.3	0.8	1.9	0.9	18.5	3.6	40.5	9.4	0.0	1.2
	13:10	18270054	0.0	2.8	0.0	14.3	1.3	0.8	2.0	0.9	18.3	3.6	40.0	9.5	0.0	1.3
	13:12	18270055	0.0	2.8	0.0	14.4	1.4	0.8	1.9	0.9	18.1	3.7	38.9	9.5	0.0	1.3
	13:14	18270056	0.0	2.9	0.0	14.6	1.4	0.8	1.9	0.9	17.9	3.7	38.5	9.6	0.0	1.3
	13:16	18270057	0.0	2.9	0.0	14.8	1.4	0.8	1.9	0.9	17.6	3.8	38.8	9.7	0.0	1.3
	13:18	18270058	0.0	3.0	0.0	15.0	1.5	0.8	1.9	0.9	17.8	3.8	39.5	9.8	0.0	1.3
	13:20	18270059	0.0	3.0	0.0	15.3	1.5	0.8	1.9	0.9	17.8	3.9	42.7	10.0	0.0	1.4
	13:21	18270060	0.0	3.1	0.0	15.4	1.5	0.8	1.9	0.9	18.1	3.9	45.5	10.1	0.0	1.4
13:23	18270061	0.0	3.0	0.0	15.4	1.5	0.8	1.9	0.9	18.6	3.9	47.4	10.0	0.0	1.4	
Average -->			0.0		0.0		1.3		2.0		18.2		42.5		0.0	

Date	Time	File Name	Toluene		Hexane		Ethylene		Methane		Sulfur Dioxide		Carbon Monoxide		Formaldehyde	
			ppm	Δ	ppm	Δ	ppm	Δ	ppm	Δ	ppm	Δ	ppm	Δ	ppm	Δ
8/28/97 Run 2	11:24	18280056	0.0	2.1	0.0	10.6	2.7	0.5	3.4	0.6	9.7	2.6	80.4	7.2	0.0	0.9
	11:25	18280057	0.0	2.7	0.0	13.7	2.9	0.7	3.0	0.8	18.2	3.4	93.6	9.6	0.0	1.2
	11:27	18280058	0.0	3.0	0.0	15.2	2.3	0.8	2.6	0.9	22.3	3.8	86.0	10.5	0.0	1.4
	11:29	18280059	0.0	3.2	0.0	16.4	2.0	0.9	2.5	1.0	23.9	4.1	97.4	11.5	0.0	1.5
	11:30	18280060	0.0	3.4	0.0	17.4	2.0	0.9	2.5	1.0	24.8	4.3	115.3	12.3	0.0	1.5
	11:32	18280061	0.0	3.5	0.0	18.0	2.1	0.9	2.4	1.1	25.7	4.4	108.9	12.5	0.0	1.6
	11:34	18280062	0.0	3.6	0.0	18.1	2.1	0.9	2.4	1.1	26.7	4.5	105.7	12.4	0.0	1.6
	11:35	18280063	0.0	3.6	0.0	18.3	2.2	1.0	2.5	1.1	27.4	4.5	108.7	12.6	0.0	1.6
	11:37	18280064	0.0	3.6	0.0	18.4	2.2	1.0	2.4	1.1	27.3	4.6	108.8	12.6	0.0	1.6
	11:40	18280065	0.0	3.7	0.0	18.8	2.2	1.0	2.4	1.1	26.7	4.7	108.9	12.8	0.0	1.7
	11:41	18280066	0.0	3.8	0.0	19.0	2.2	1.0	2.5	1.1	26.3	4.7	104.7	12.8	0.0	1.7
	11:43	18280067	0.0	3.8	0.0	19.4	2.3	1.0	2.5	1.2	26.0	4.8	104.3	12.9	0.0	1.7
	11:45	18280068	0.0	3.9	0.0	19.5	2.3	1.0	2.5	1.2	25.3	4.8	99.6	12.8	0.0	1.7
	11:46	18280069	0.0	3.9	0.0	19.7	2.2	1.0	2.5	1.2	24.7	4.9	90.6	12.7	0.0	1.8
	11:48	18280070	0.0	3.9	0.0	19.9	2.3	1.0	2.5	1.2	23.8	4.9	91.4	12.8	0.0	1.8
	11:50	18280071	0.0	4.0	0.0	20.1	2.3	1.0	2.5	1.2	23.4	5.0	94.7	13.0	0.0	1.8
	11:51	18280072	0.0	4.0	0.0	20.2	2.3	1.1	2.6	1.2	23.2	5.0	91.2	12.9	0.0	1.8
11:53	18280073	0.0	4.0	0.0	20.1	2.3	1.1	2.6	1.2	23.2	5.0	85.8	12.8	0.0	1.8	
Average -->			0.0		0.0		2.3		2.6		23.8		98.7		0.0	

TABLE B-4. Continued. Results of Dry Outlet Samples.

Date	Time	File Name	Toluene		Hexane		Ethylene		Methane		Sulfur Dioxide		Carbon Monoxide		Formaldehyde		
			ppm	Δ	ppm	Δ	ppm	Δ	ppm	Δ	ppm	Δ	ppm	Δ	ppm	Δ	
8/29/97 Run 3	11:30	18290056	0.0	3.5	0.0	17.5	1.5	0.9	2.1	1.1	11.0	4.3	49.5	10.6	0.0	1.6	
	11:31	18290057	0.0	3.2	0.0	16.2	1.5	0.9	2.0	1.0	8.3	4.1	52.3	10.1	0.0	1.4	
	11:33	18290058	0.0	3.1	0.0	15.7	1.5	0.8	2.0	1.0	7.3	3.9	52.7	9.8	0.0	1.4	
	11:35	18290059	0.0	3.1	0.0	15.6	1.4	0.8	1.9	0.9	6.8	3.9	52.6	9.7	0.0	1.4	
	11:36	18290060	0.0	3.1	0.0	15.4	1.5	0.8	1.9	0.9	6.5	3.9	52.1	9.7	0.0	1.4	
	11:38	18290061	0.0	3.0	0.0	15.4	1.5	0.8	1.9	0.9	6.3	3.9	50.9	9.6	0.0	1.4	
	11:41	18290062	0.0	3.0	0.0	15.1	1.4	0.8	1.9	0.9	6.3	3.8	48.9	9.5	0.0	1.3	
	11:42	18290063	0.0	2.9	0.0	14.9	1.4	0.8	1.8	0.9	6.4	3.8	45.6	9.3	0.0	1.3	
	11:44	18290064	0.0	2.9	0.0	14.8	1.4	0.8	2.1	0.9	6.6	3.7	43.6	9.2	0.0	1.3	
	11:46	18290065	0.0	2.9	0.0	14.7	1.5	0.8	2.2	0.9	6.8	3.7	42.7	9.2	0.0	1.3	
	11:47	18290066	0.0	2.9	0.0	14.7	1.5	0.8	2.2	0.9	6.9	3.7	43.7	9.2	0.0	1.3	
	11:49	18290067	0.0	2.9	0.0	14.7	1.5	0.8	2.2	0.9	6.7	3.7	44.7	9.2	0.0	1.3	
	8/29/97 Run 3	11:50	18290068	0.0	2.9	0.0	14.6	1.5	0.8	2.1	0.9	6.7	3.7	46.0	9.2	0.0	1.3
		11:52	18290069	0.0	2.9	0.0	14.5	1.5	0.8	2.1	0.9	6.8	3.7	48.4	9.2	0.0	1.3
11:54		18290070	0.0	2.9	0.0	14.5	1.5	0.8	2.1	0.9	7.0	3.7	49.0	9.2	0.0	1.3	
11:56		18290071	0.0	2.9	0.0	14.5	1.4	0.8	2.1	0.9	7.1	3.7	47.6	9.1	0.0	1.3	
11:58		18290072	0.0	2.9	0.0	14.5	1.4	0.8	2.1	0.9	7.2	3.7	47.9	9.1	0.0	1.3	
	12:00	18290073	0.0	2.8	0.0	14.4	1.4	0.8	2.1	0.9	7.2	3.7	48.4	9.1	0.0	1.3	
Average --->			0.0		0.0		1.5		2.1		7.1		48.1		0.0		

TABLE B-4. Continued. Additional Hydrocarbon Results of Dry Outlet Samples

Date	Time	File Name	3-Methylpentane		Isooctane		Heptane		1-Pentene		2-Methyl-2-butene		n-Pentane	
			ppm	Δ	ppm	Δ	ppm	Δ	ppm	Δ	ppm	Δ	ppm	Δ
8/27/97 Run 1	12:58	18270047	0.0	1.2	0.0	0.9	8.4	0.2	0.0	2.9	0.0	1.4	0.0	2.5
	13:01	18270048	0.0	0.9	0.0	0.9	8.5	0.2	0.0	2.3	0.0	1.3	0.0	13.3
	13:02	18270049	0.0	0.9	0.0	0.9	8.2	0.2	0.0	2.3	0.0	1.3	0.0	13.3
	13:04	18270050	0.0	0.6	0.0	0.9	7.8	0.2	0.0	2.3	0.0	1.3	0.0	13.3
	13:06	18270051	0.0	0.6	0.0	0.9	7.4	0.2	0.0	2.3	0.0	1.3	0.0	13.3
	13:07	18270052	0.0	0.6	0.0	0.9	7.3	0.2	0.0	2.3	0.0	1.4	0.0	13.5
	13:09	18270053	0.0	0.6	0.0	0.9	7.5	0.2	0.0	2.4	0.0	1.4	0.0	13.7
	13:10	18270054	0.0	0.9	0.0	1.0	7.7	0.2	0.0	2.4	0.0	1.4	0.0	14.0
	13:12	18270055	0.0	0.9	0.0	1.0	7.8	0.2	0.0	2.4	0.0	1.4	0.0	14.1
	13:14	18270056	0.0	1.0	0.0	1.0	7.6	0.2	0.0	2.5	0.0	1.4	0.0	14.3
	13:16	18270057	0.0	1.0	0.0	1.0	7.2	0.2	0.0	2.5	0.0	1.5	0.0	14.5
	13:18	18270058	0.0	1.0	0.0	1.0	7.0	0.2	0.0	2.5	0.0	1.5	0.0	14.7
	13:20	18270059	0.0	1.0	0.0	1.0	6.8	0.2	0.0	2.6	0.0	1.5	0.0	15.0
	13:21	18270060	0.0	1.0	0.0	1.0	6.7	0.2	0.0	2.6	0.0	1.5	0.0	15.1
13:23	18270061	0.0	1.0	0.0	1.0	6.8	0.2	0.0	2.6	0.0	1.5	0.0	15.1	
Average --->			0.0		0.0		7.5		0.0		0.0		0.0	

Date	Time	File Name	3-Methylpentane		Isooctane		Heptane		1-Pentene		2-Methyl-2-butene		n-Pentane		
			ppm	Δ	ppm	Δ	ppm	Δ	ppm	Δ	ppm	Δ	ppm	Δ	
8/28/97 Run 2	11:24	18280056	0.0	0.8	0.0	0.3	9.0	0.2	0.0	1.8	0.0	0.9	0.0	10.4	
	11:25	18280057	0.0	1.1	0.0	0.3	8.3	0.2	0.0	2.3	0.0	1.5	0.0	13.5	
	11:27	18280058	0.0	0.9	0.0	1.0	7.3	0.2	0.0	2.2	0.0	4.8	0.0	14.9	
	11:29	18280059	0.0	1.0	0.0	1.1	6.8	0.3	0.0	2.4	0.0	5.2	0.0	16.1	
	11:30	18280060	0.0	1.1	0.0	1.2	6.5	0.3	0.0	2.6	0.0	5.5	0.0	17.0	
	11:32	18280061	0.0	1.1	0.0	1.2	6.5	0.3	0.0	2.6	0.0	5.7	0.0	17.6	
	11:34	18280062	0.0	1.1	0.0	1.2	6.8	0.3	0.0	2.7	0.0	5.7	0.0	17.8	
	11:35	18280063	0.0	1.1	0.0	1.2	7.2	0.3	0.0	2.7	0.0	5.8	0.0	18.0	
	8/28/97 Run 2	11:37	18280064	0.0	1.1	0.0	1.2	7.4	0.3	0.0	2.7	0.0	5.8	0.0	18.0
	11:40	18280065	0.0	1.2	0.0	1.3	7.4	0.3	0.0	2.8	0.0	6.0	0.0	18.4	
11:41	18280066	0.0	1.2	0.0	1.3	7.7	0.3	0.0	2.8	0.0	6.0	0.0	18.6		
11:43	18280067	0.0	1.2	0.0	1.3	7.5	0.3	0.0	2.9	0.0	6.1	0.0	19.0		
11:45	18280068	0.0	1.2	0.0	1.3	7.4	0.3	0.0	2.9	0.0	6.2	0.0	19.1		
11:46	18280069	0.0	1.2	0.0	1.3	7.5	0.3	0.0	2.9	0.0	6.2	0.0	19.3		
11:48	18280070	0.0	1.2	0.0	1.3	7.9	0.3	0.0	2.9	0.0	6.3	0.0	19.5		
11:50	18280071	0.0	1.7	0.0	1.4	8.7	0.3	0.0	3.7	0.0	6.4	0.0	3.6		
11:51	18280072	0.0	1.7	0.0	1.4	9.4	0.3	0.0	3.7	0.0	6.4	0.0	3.6		
11:53	18280073	0.0	1.7	0.0	1.4	10.0	0.3	0.0	2.1	0.0	2.0	0.0	3.7		
Average --->			0.0		0.0		7.7		0.0		0.0		0.0		

TABLE B-4. Continued. Additional Hydrocarbon Results of Dry Outlet Samples

Date	Time	File Name	3-Methylpentane		Isooctane		Heptane		1-Pentene		2-Methyl-2-butene		n-Pentane	
			ppm	$\Delta$	ppm	$\Delta$	ppm	$\Delta$	ppm	$\Delta$	ppm	$\Delta$	ppm	$\Delta$
8/29/97 Run 3	11:30	18290056	0.0	1.5	0.0	1.2	5.9	0.3	0.0	3.7	0.0	1.8	0.0	3.2
	11:31	18290057	0.0	1.4	0.0	1.1	5.4	0.3	0.0	3.5	0.0	1.6	0.0	3.0
	11:33	18290058	0.0	0.7	0.0	1.1	5.0	0.2	0.0	3.3	0.0	1.6	0.0	2.9
	11:35	18290059	0.0	0.7	0.0	1.1	4.6	0.2	0.0	3.3	0.0	1.6	0.0	2.9
	11:36	18290060	0.0	0.7	0.0	1.0	4.2	0.2	0.0	3.3	0.0	1.6	0.0	2.9
	11:38	18290061	0.0	1.0	0.0	1.0	4.0	0.2	0.0	2.6	0.0	1.5	0.0	15.1
	11:41	18290062	0.0	1.0	0.0	1.0	3.8	0.2	0.0	2.5	0.0	1.5	0.0	14.8
	11:42	18290063	0.0	0.7	0.0	1.0	3.6	0.2	0.0	2.2	0.0	4.7	0.0	14.6
	11:44	18290064	2.8	0.9	0.0	1.0	0.0	6.4	2.1	2.0	0.0	4.7	0.0	14.5
	11:46	18290065	3.5	0.3	0.0	1.0	0.0	6.3	0.0	2.0	0.0	4.6	0.0	14.4
	11:47	18290066	3.4	0.3	0.0	1.0	0.0	6.4	0.0	2.0	0.0	4.7	0.0	14.4
	11:49	18290067	3.4	0.3	0.0	1.0	0.0	6.3	0.0	2.0	0.0	4.6	0.0	14.4
	11:50	18290068	3.3	0.3	0.0	1.0	0.0	6.3	0.0	2.0	0.0	4.6	0.0	14.3
	11:52	18290069	3.2	0.3	0.0	1.0	0.0	6.3	0.0	2.5	0.0	1.3	0.0	14.2
	11:54	18290070	3.2	0.3	0.0	1.0	0.0	6.3	0.0	2.0	0.0	4.6	0.0	14.2
	11:56	18290071	3.1	0.3	0.0	1.0	0.0	6.3	0.0	2.0	0.0	4.6	0.0	14.2
	11:58	18290072	3.1	0.3	0.0	1.0	0.0	6.3	0.0	2.0	0.0	4.6	0.0	14.2
12:00	18290073	3.0	0.3	0.0	1.0	0.0	6.2	0.0	2.0	0.0	4.6	0.0	14.1	
Average --->			1.8		0.0		2.0		0.1		0.0		0.0	



The graphs on the following pages show concentration versus time plots of the FTIR results presented in Tables B-1 to B-4. Each graph shows the FTIR results from a single day (Test Run) and for a single analyte. Runs 1, 2 and 3 occurred on 8/27/97, 8/28/97 and on 8/29/97, respectively.

Each result is plotted as a graphical symbol and the results are connected by a solid line. Four different symbols represent the wet and dry inlet results and the wet and dry outlet results. The connecting lines are broken whenever there was a switch between test locations or type of sample treatment (i.e., wet or dry sample). Taken together, the semi-continuous results on each graph show the emission pattern for each analyte for that Run.



### Baghouse Inlet and Outlet Concentrations vs. Time Run 2 - 8/28/97

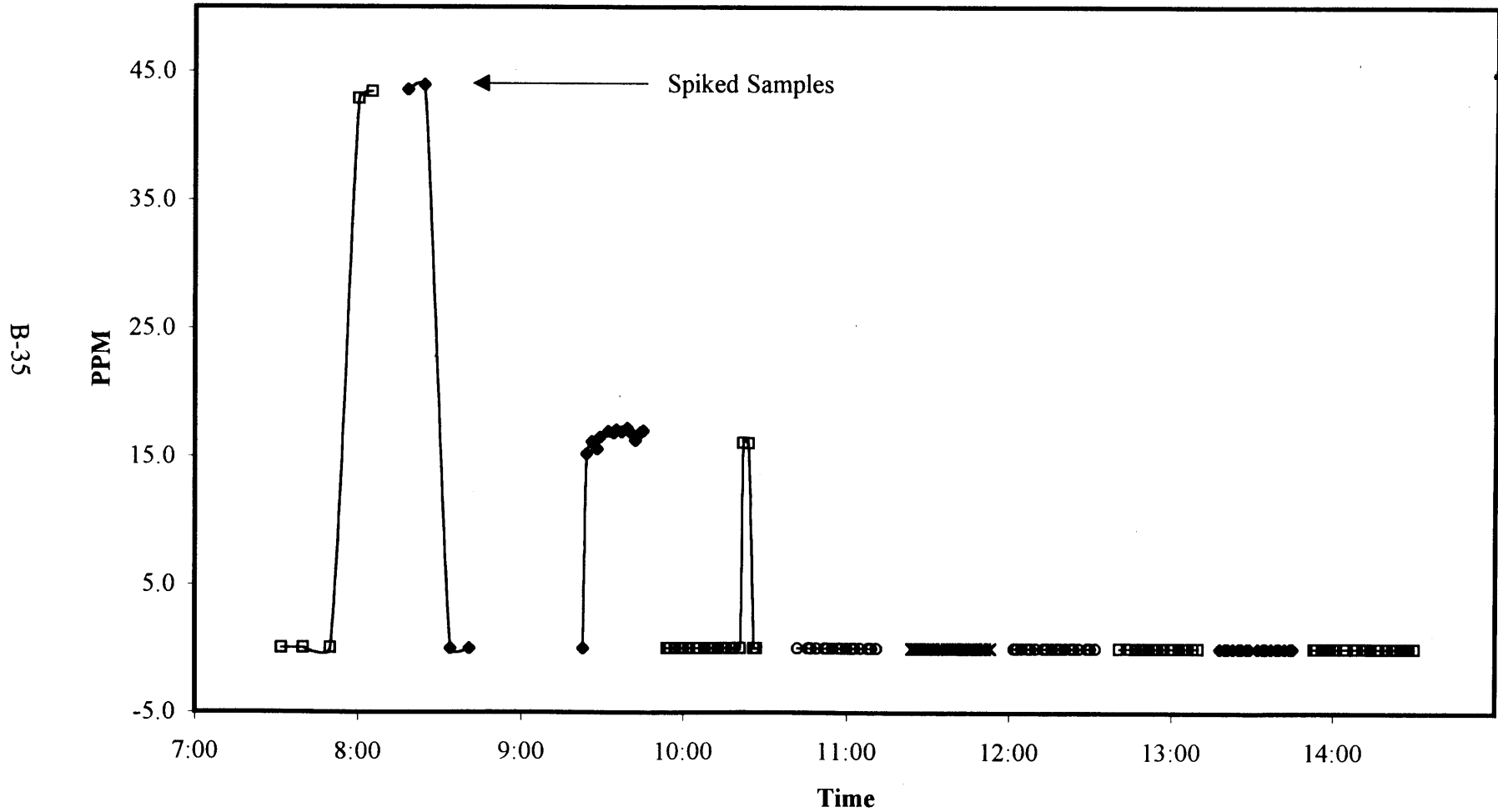

**Baghouse Inlet and Outlet Concentrations vs. Time**  
**Run 3 - 8/29/97**



B-36

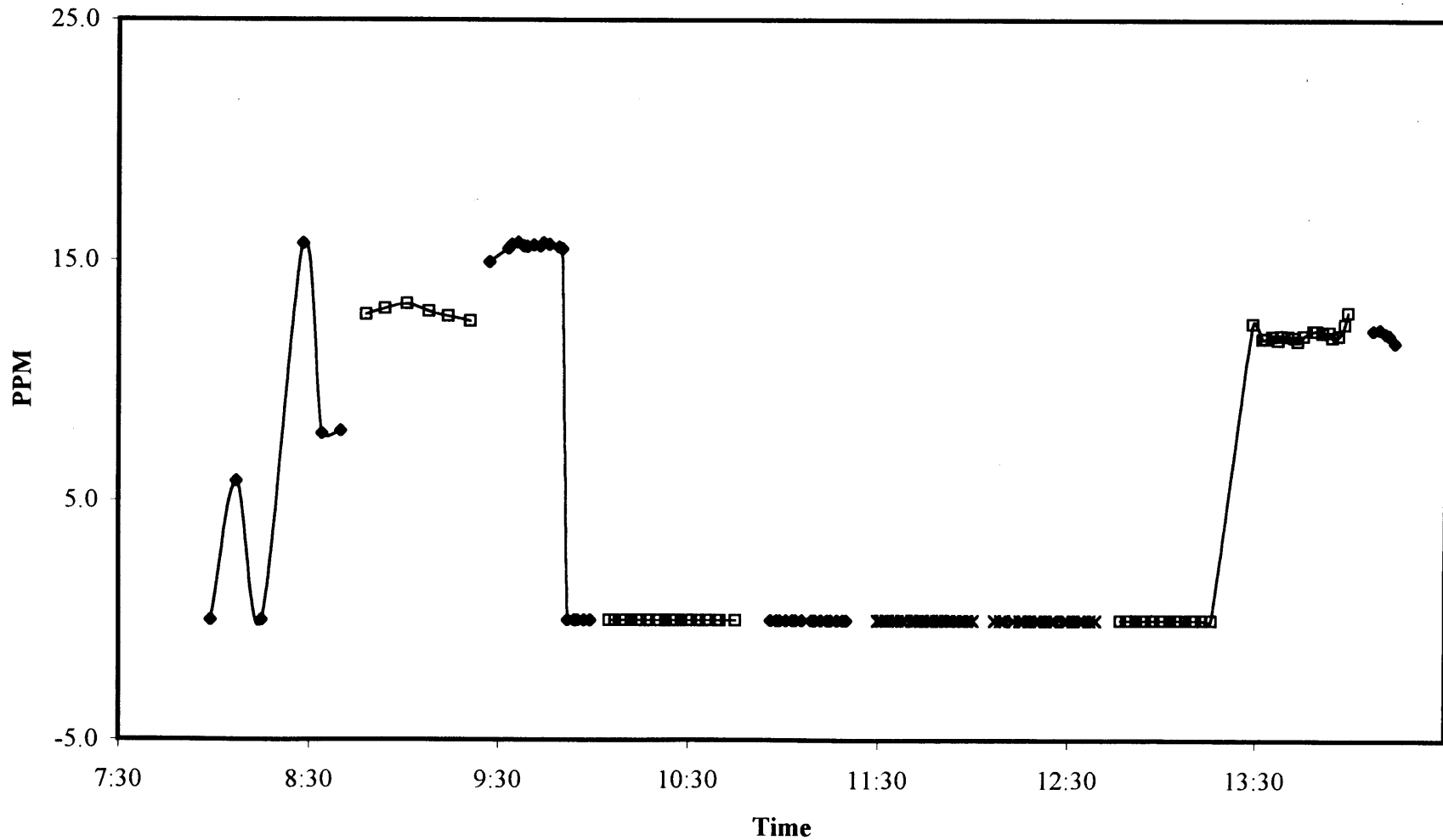

### Baghouse Inlet and Outlet Concentrations vs. Time 8/27/97

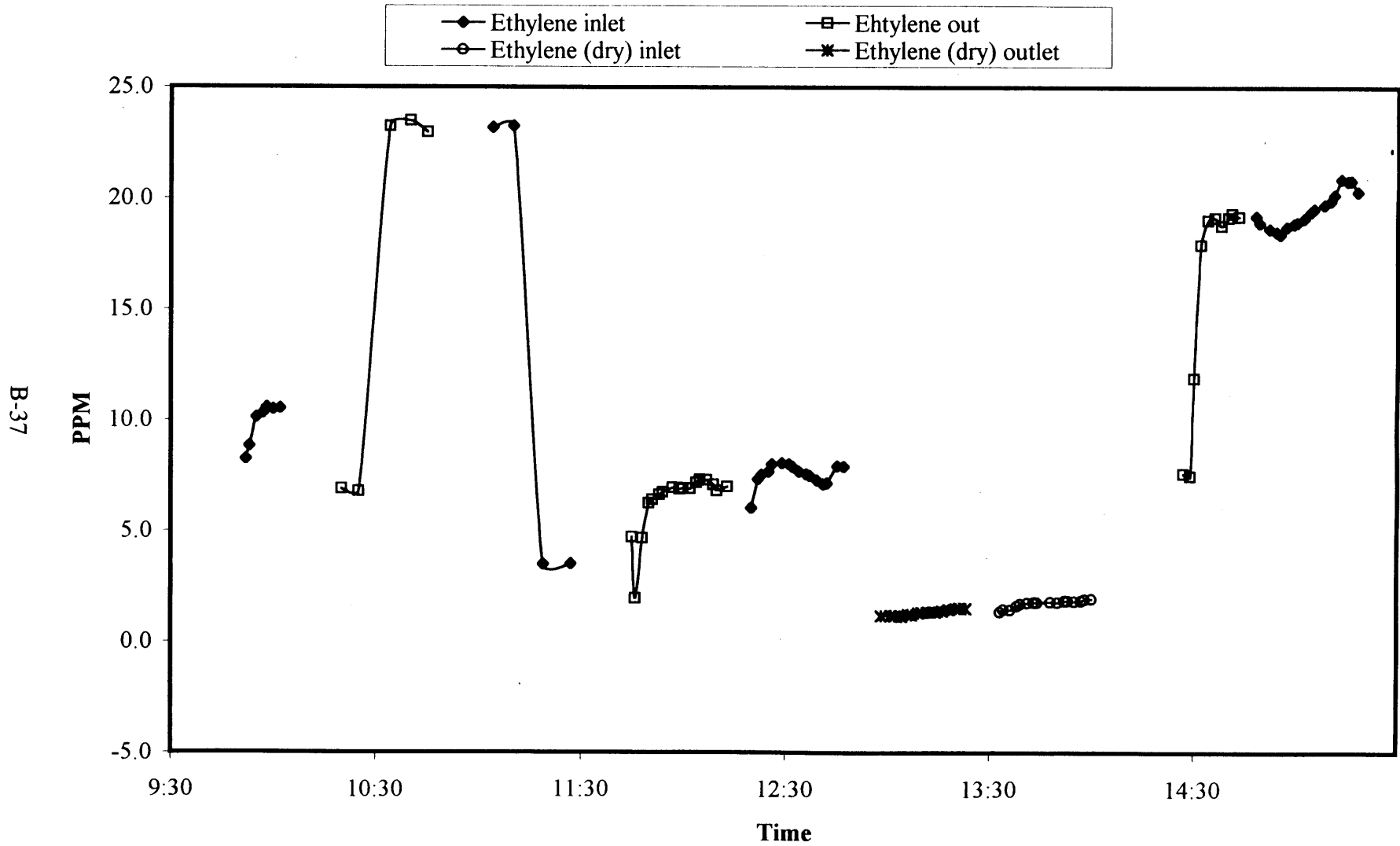

**Baghouse Inlet and Outlet Concentrations vs. Time**  
**Run 2 - 8/28/97**

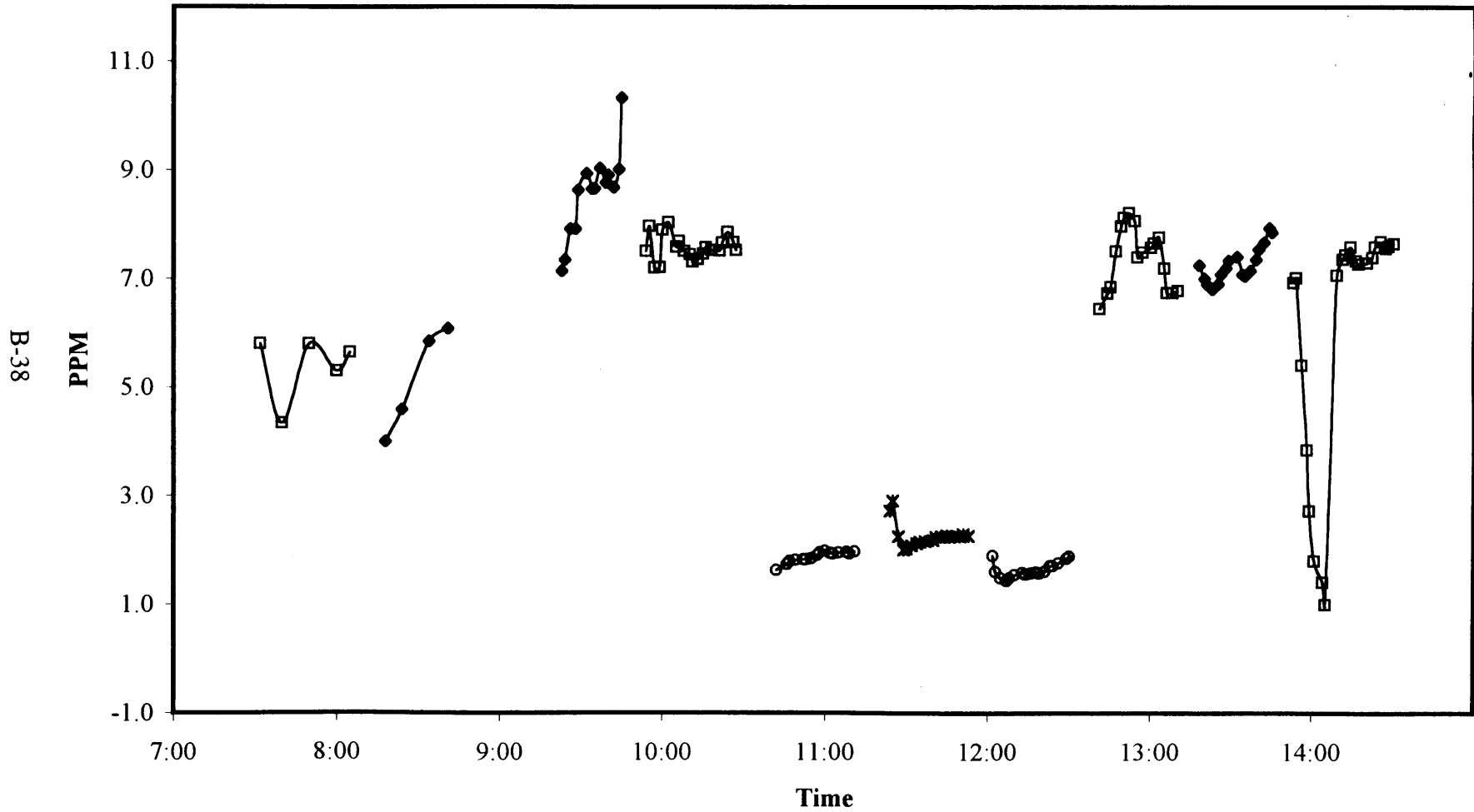

# Baghouse Inlet and Outlet Concentrations vs. Time

Run 3 - 8/29/97

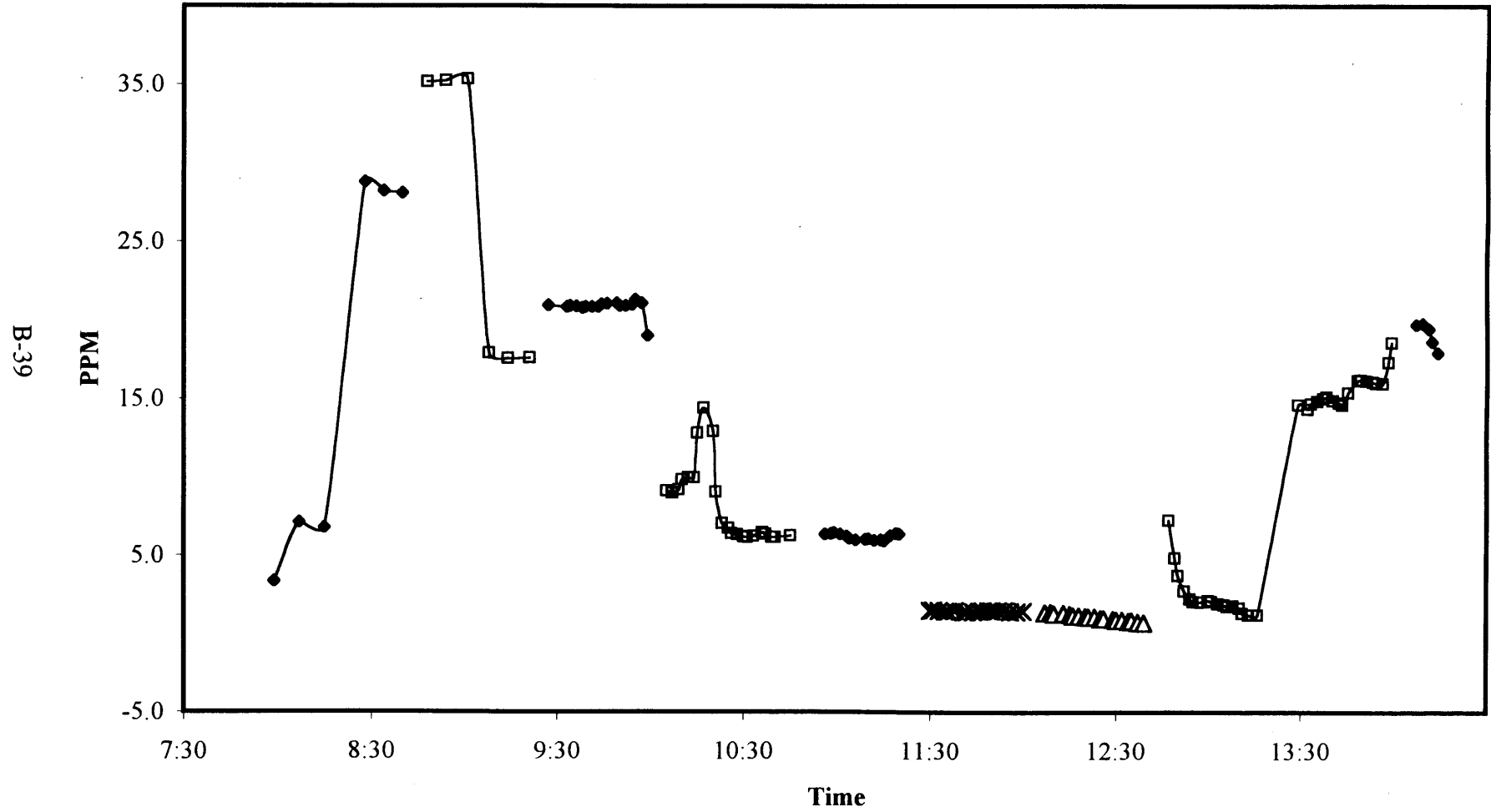

# Baghouse Inlet and Outlet Concentrations vs. Time

8/27/97

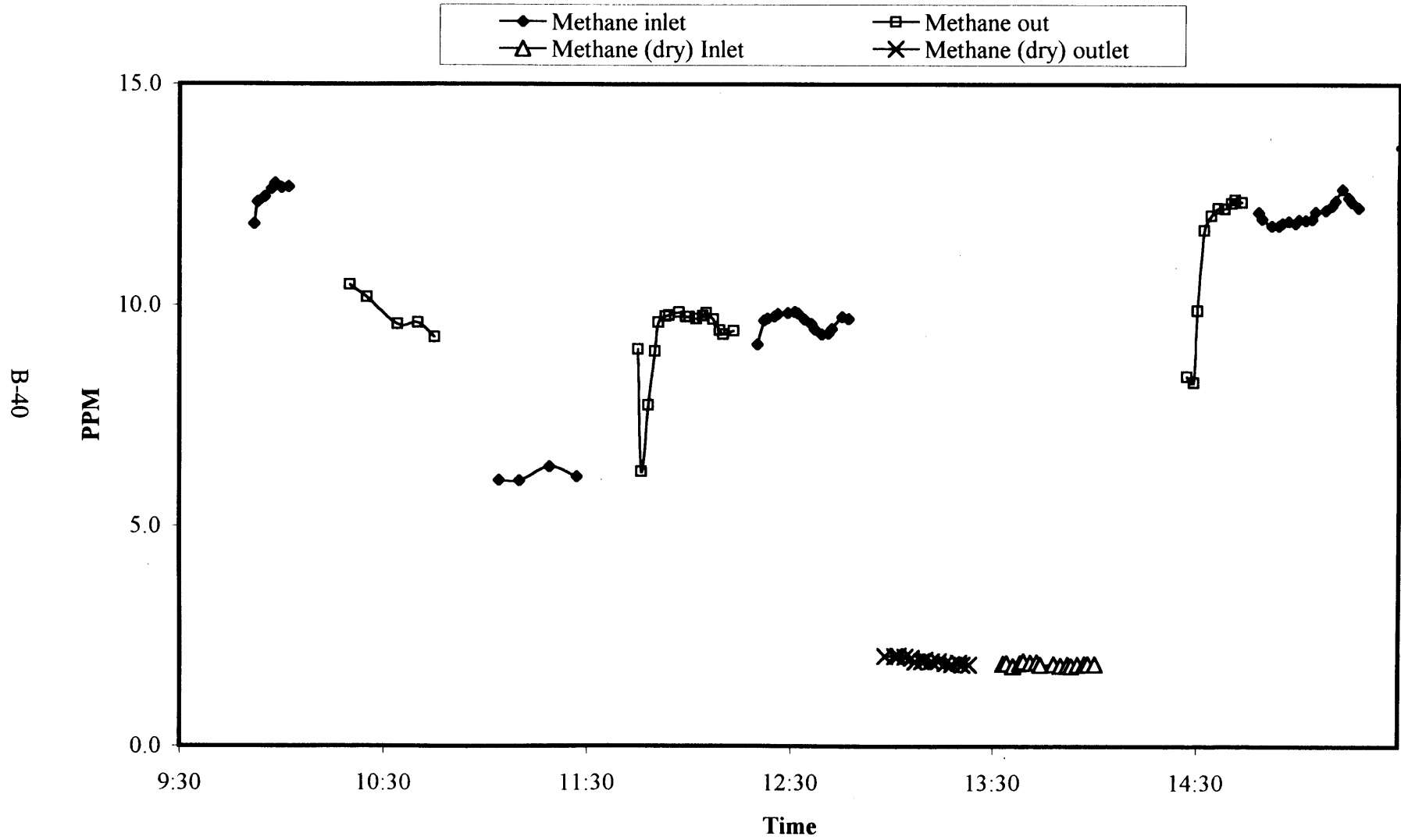



### Baghouse Inlet and Outlet Concentrations vs. Time Run 2 - 8/28/97

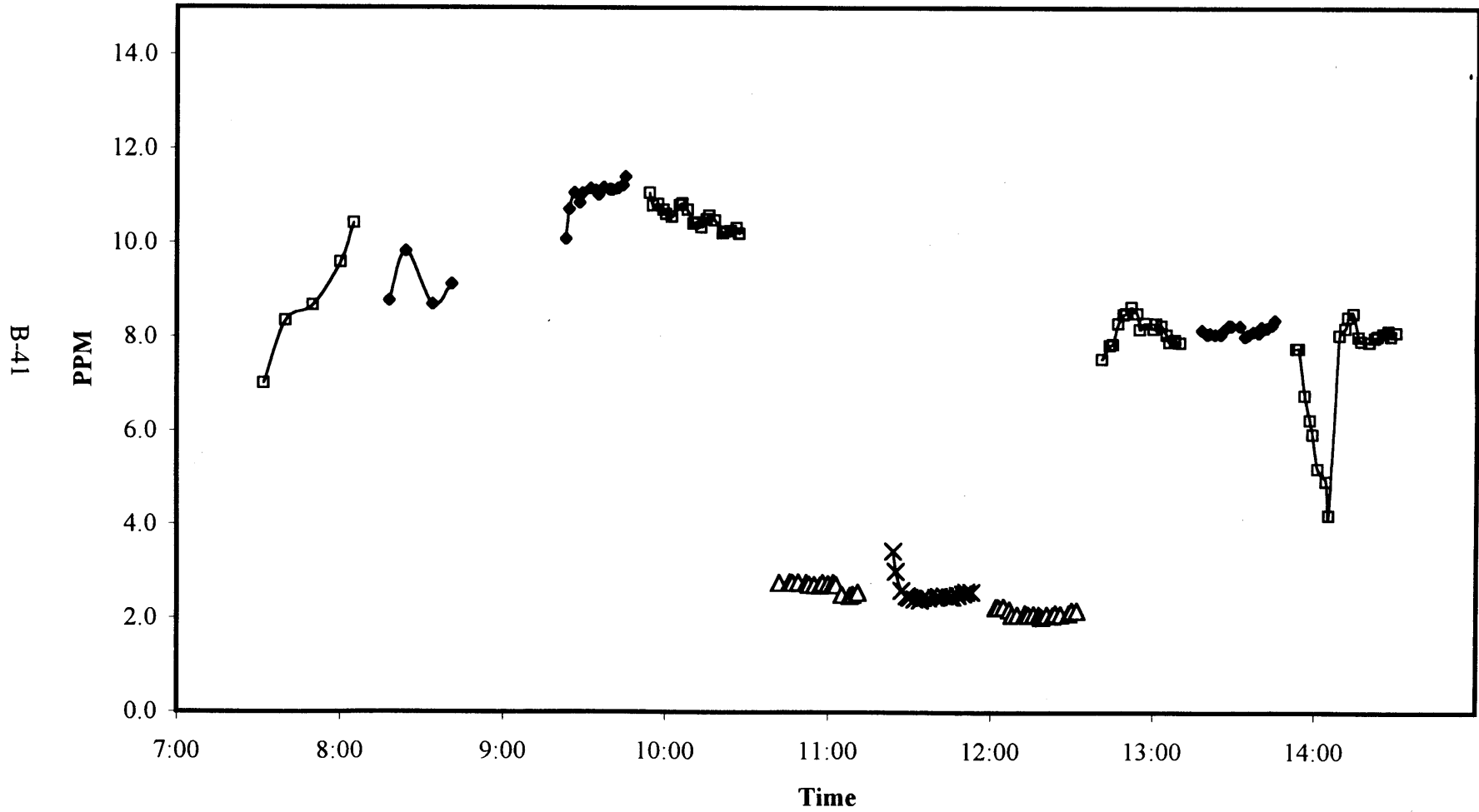

**Baghouse Inlet and Outlet Concentrations vs. Time**  
**Run 3 - 8/29/97**

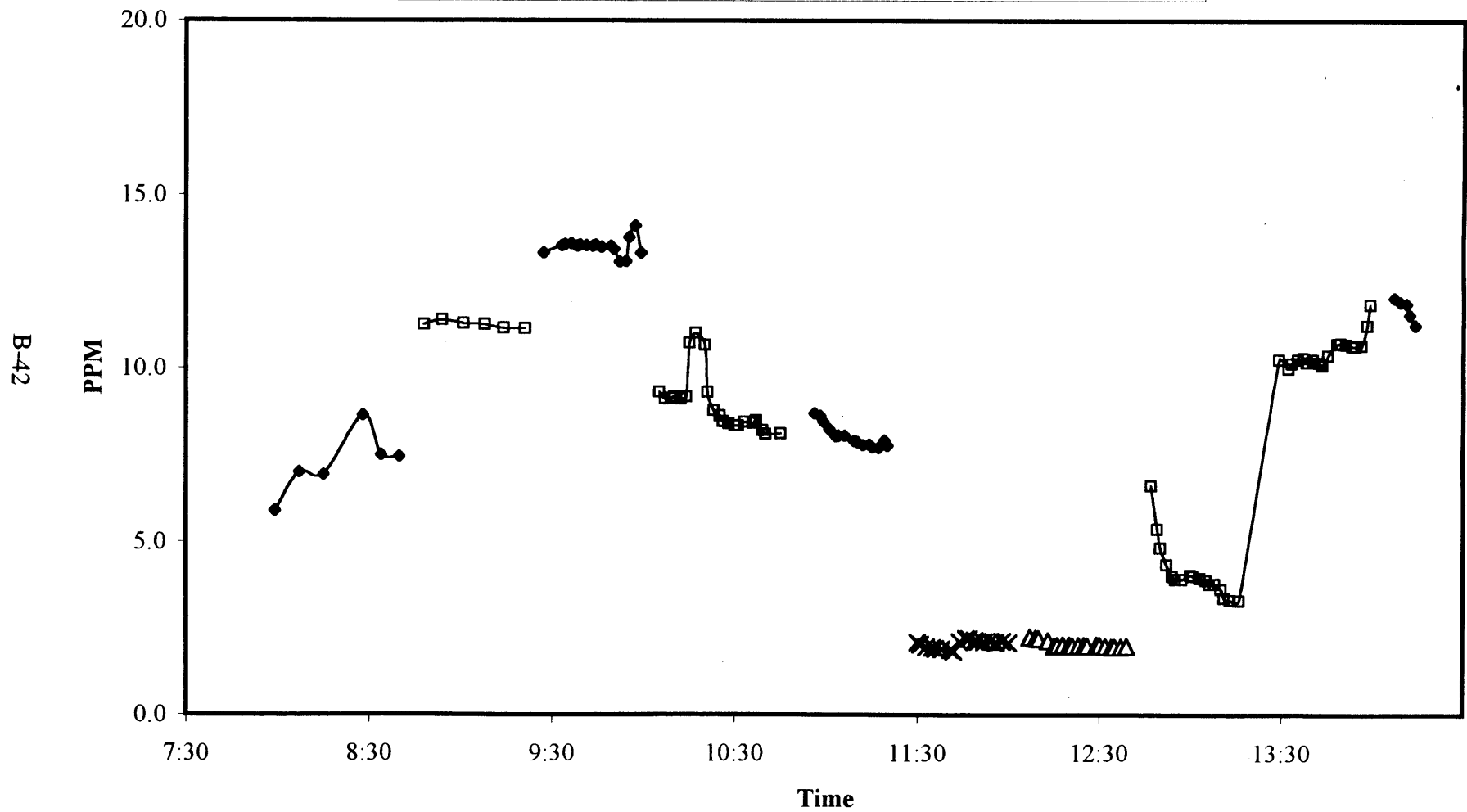
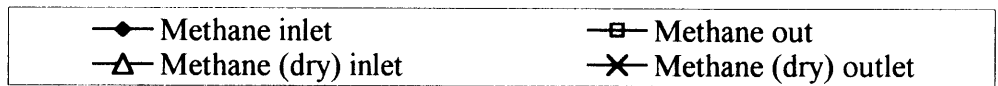

**Baghouse Inlet and Outlet Concentrations vs. Time**  
**8/27/97**

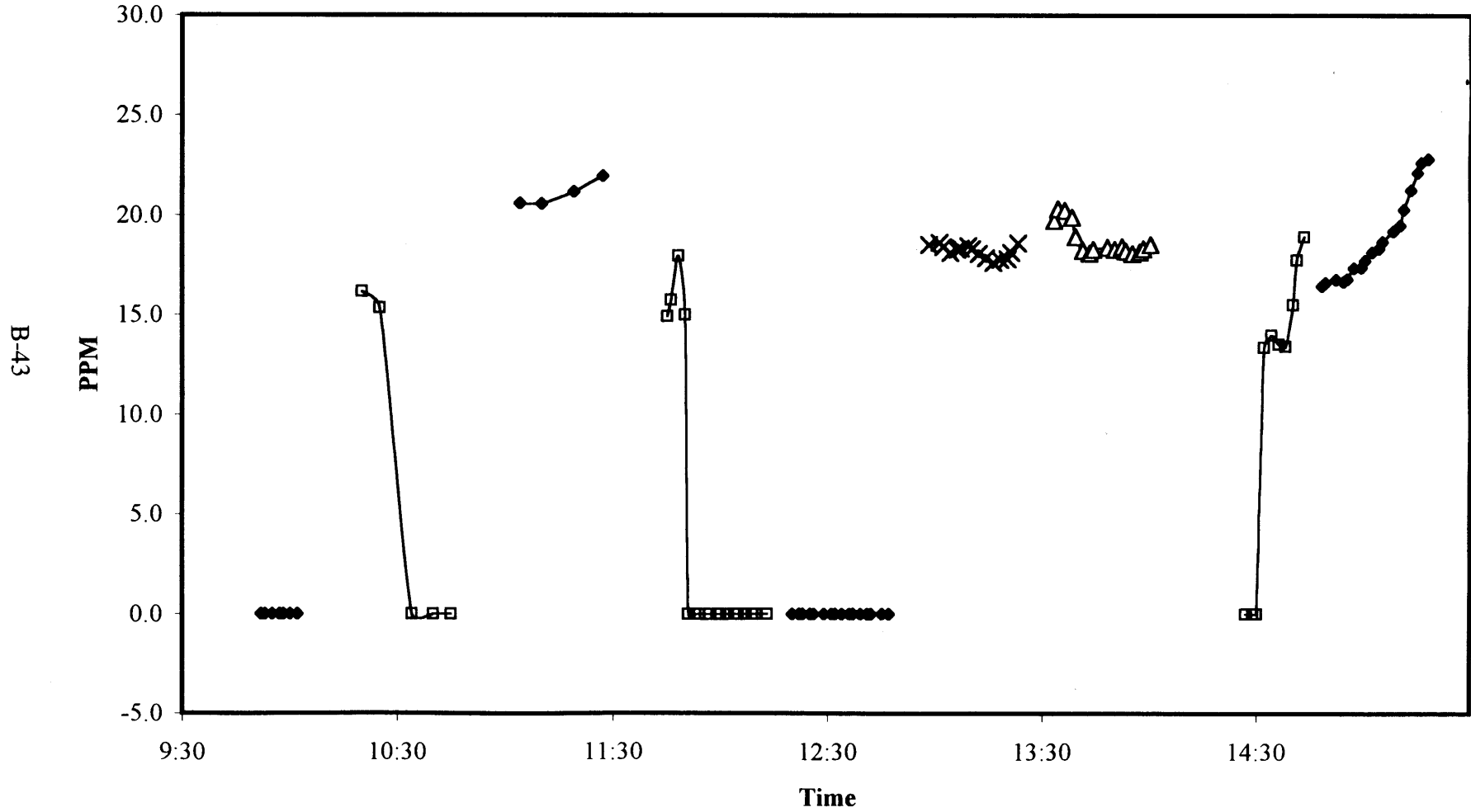

# Baghouse Inlet and Outlet Concentrations vs. Time

Run 2 - 8/28/97

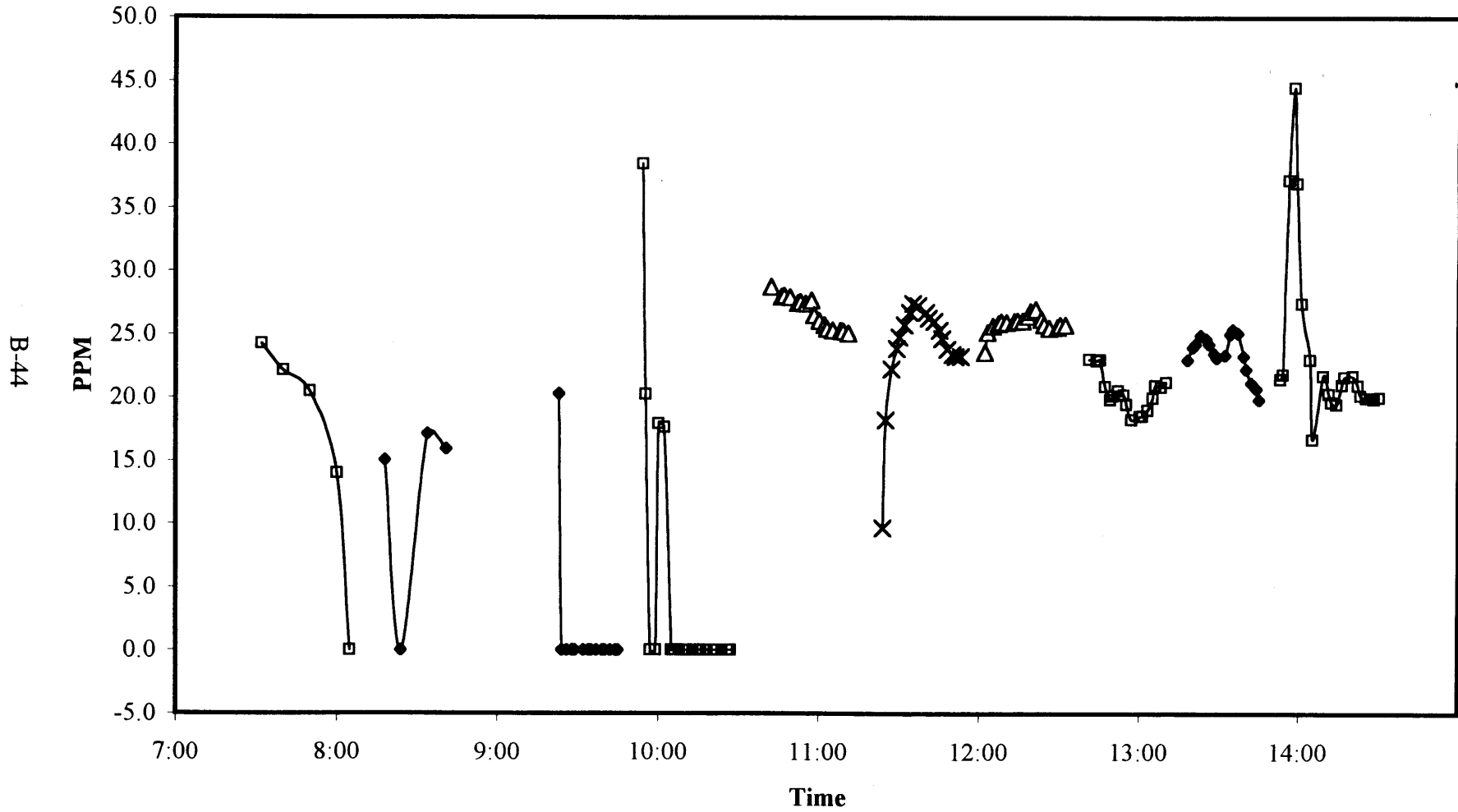

B-44

**Baghouse Inlet and Outlet Concentrations vs. Time**  
**Run 3 - 8/29/97**

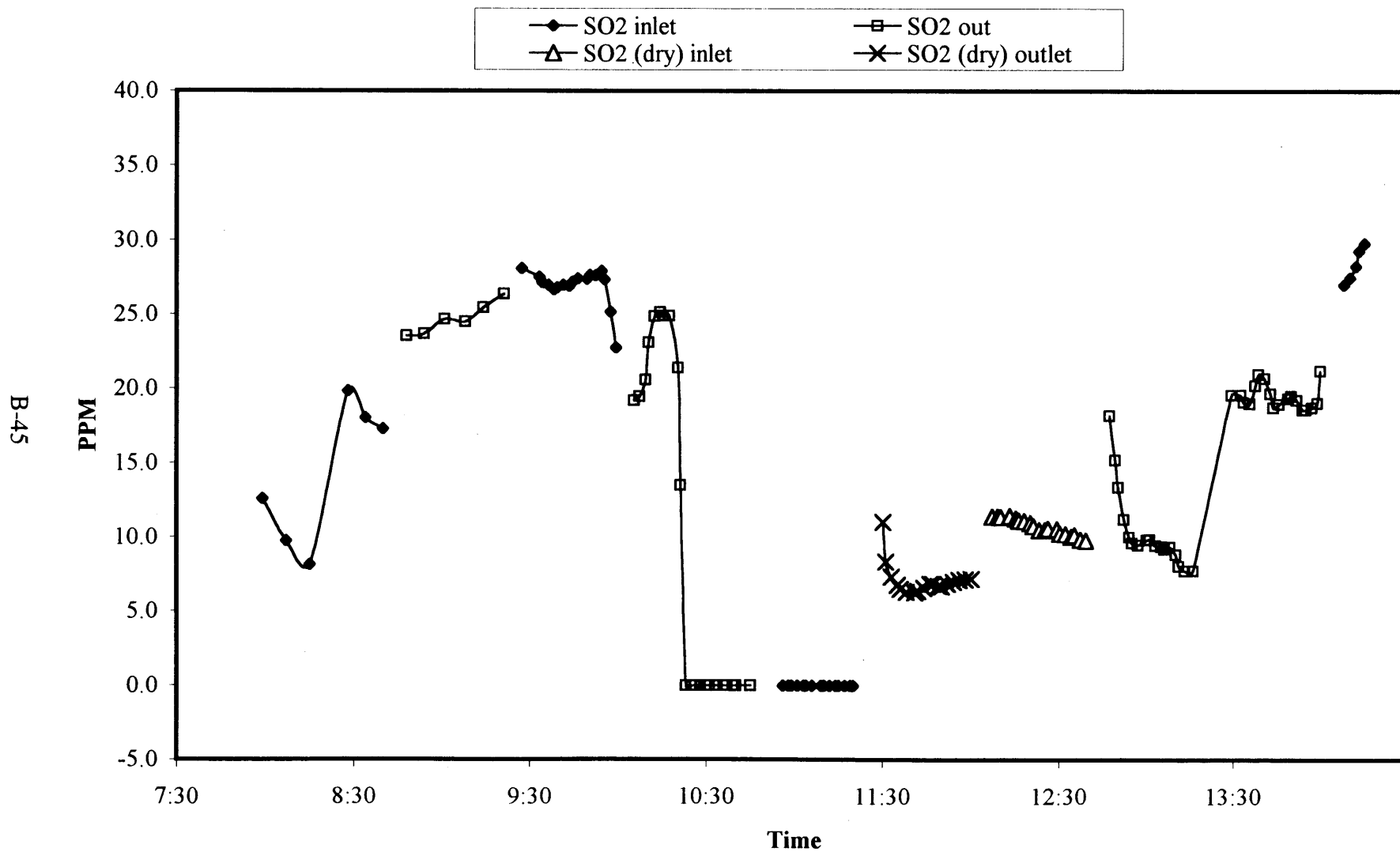

### Baghouse Inlet and Outlet Concentrations vs. Time 8/27/97

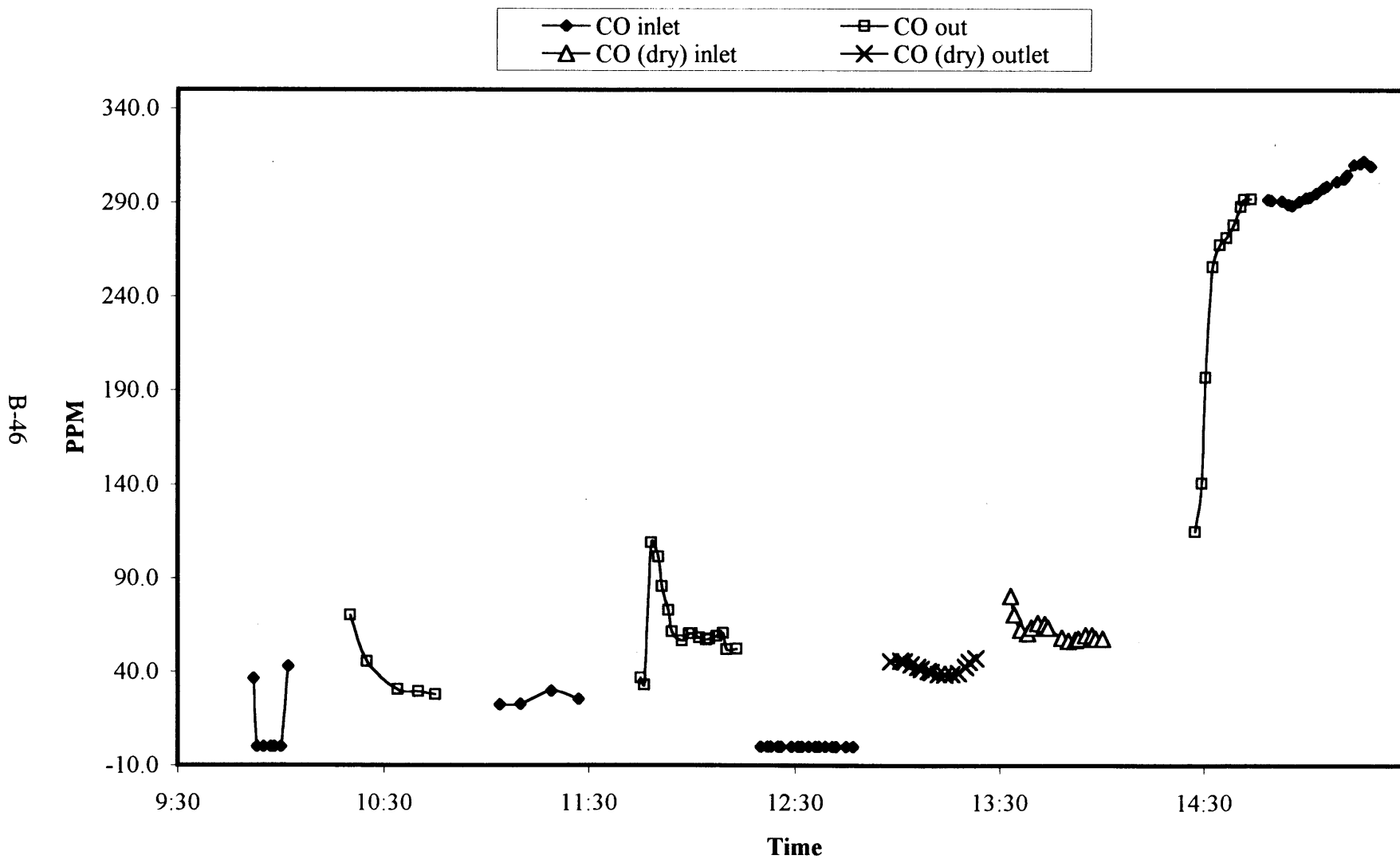

# Baghouse Inlet and Outlet Concentrations vs. Time

Run 2 - 8/28/97



B-47

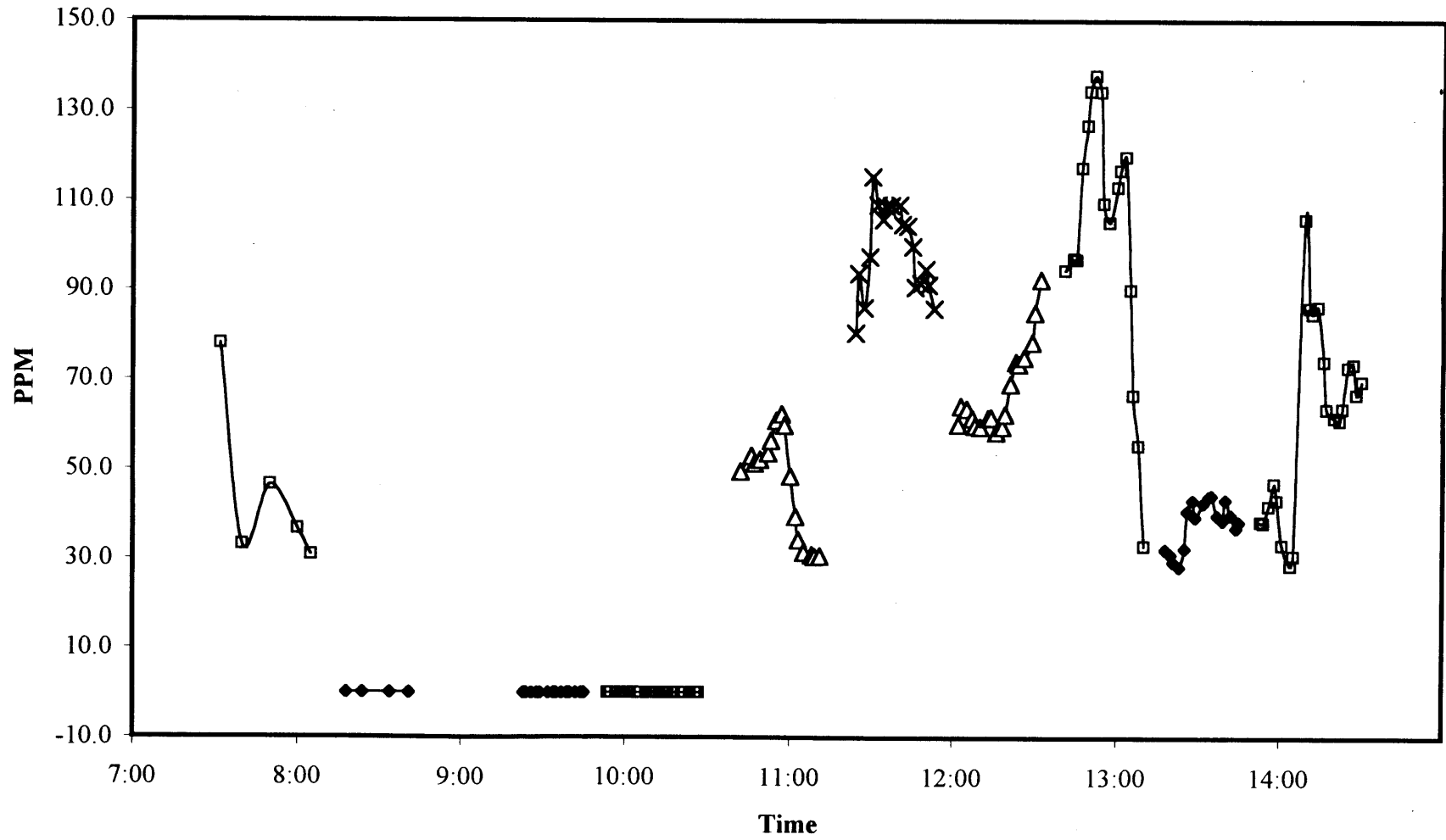

### Baghouse Inlet and Outlet Concentrations vs. Time 8/29/97

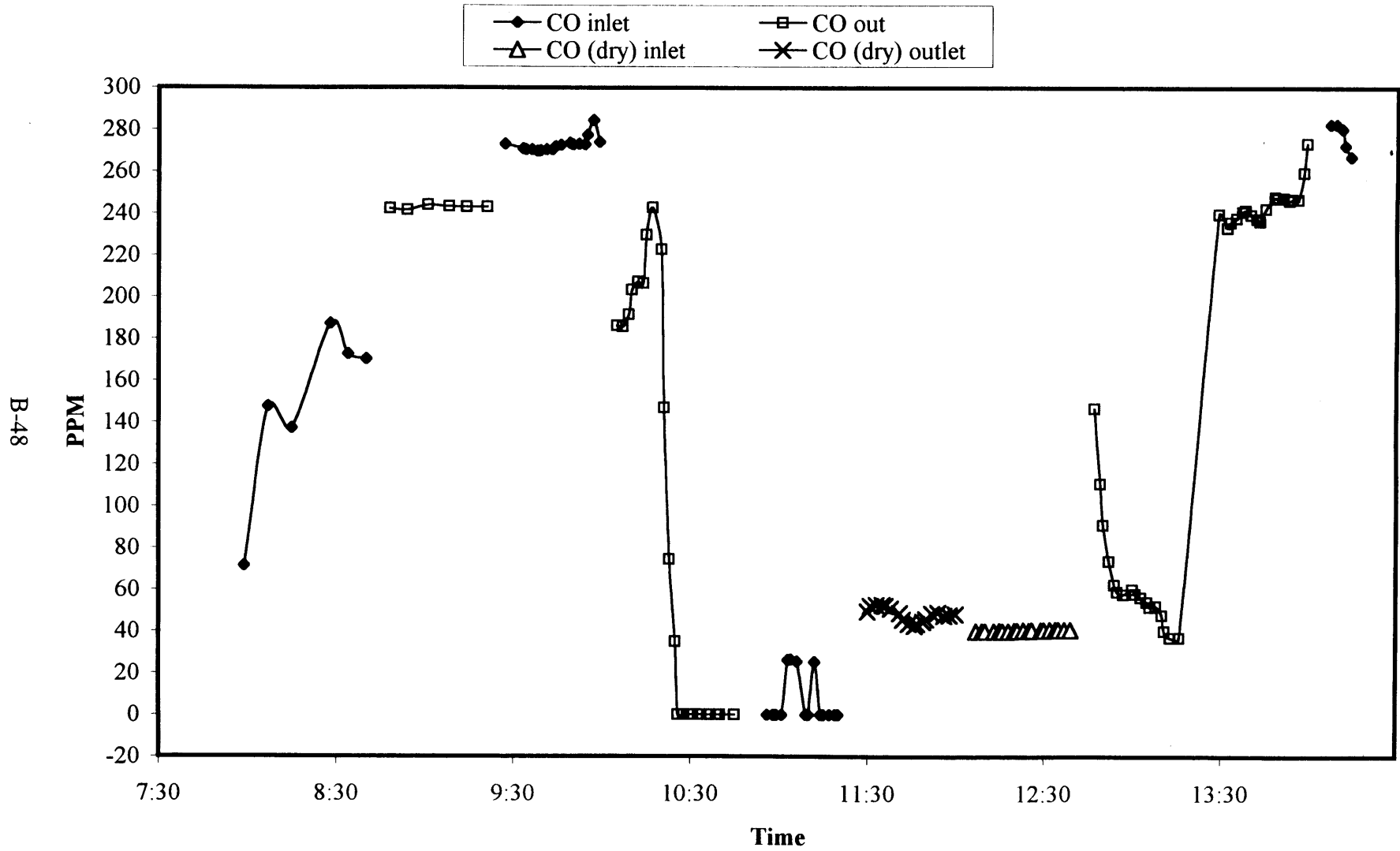



**Baghouse Inlet and Outlet Concentrations vs. Time  
(Untreated Samples). 8/27/97**

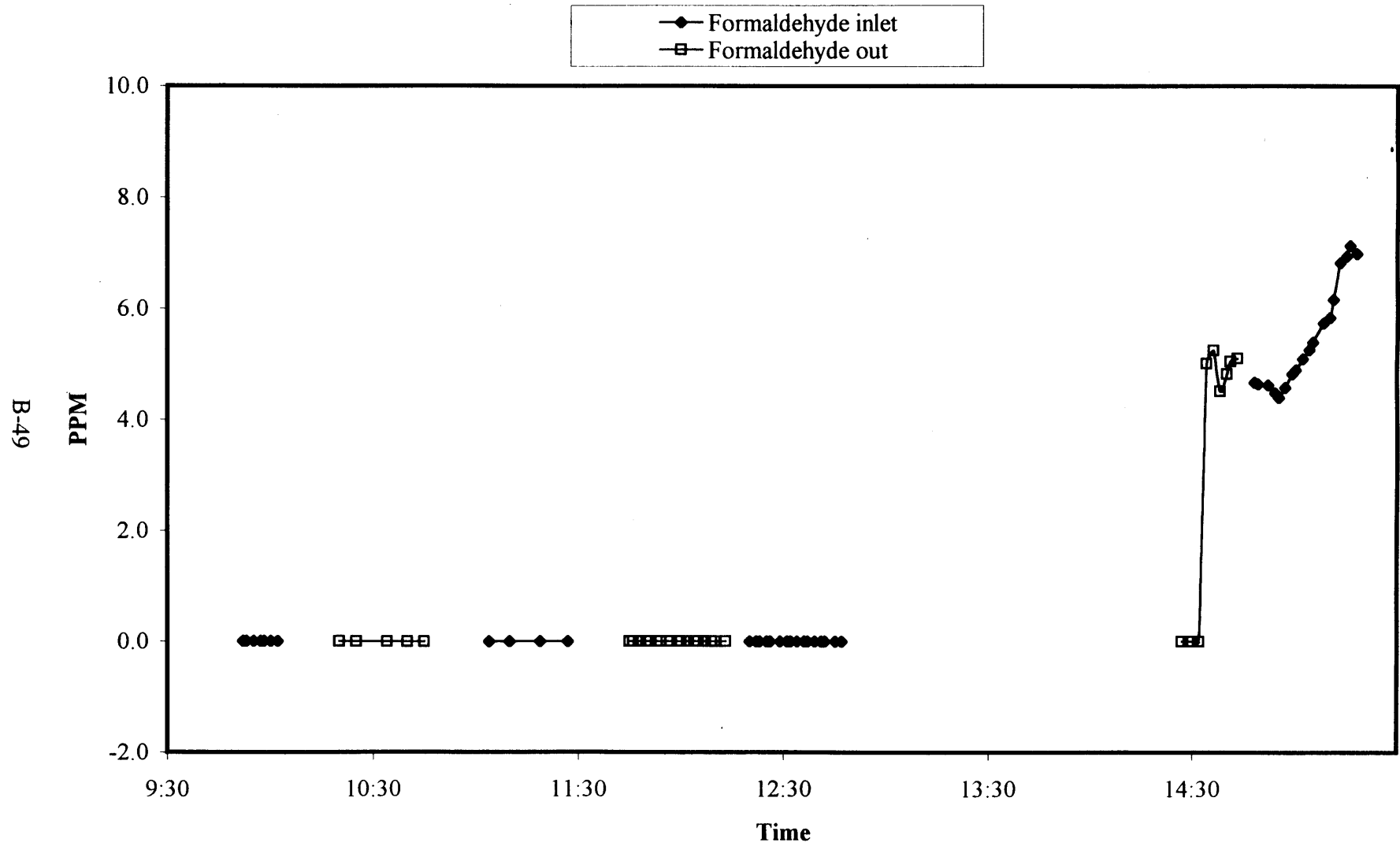

# Baghouse Inlet and Outlet Concentrations vs. Time

Run 2 - 8/28/97

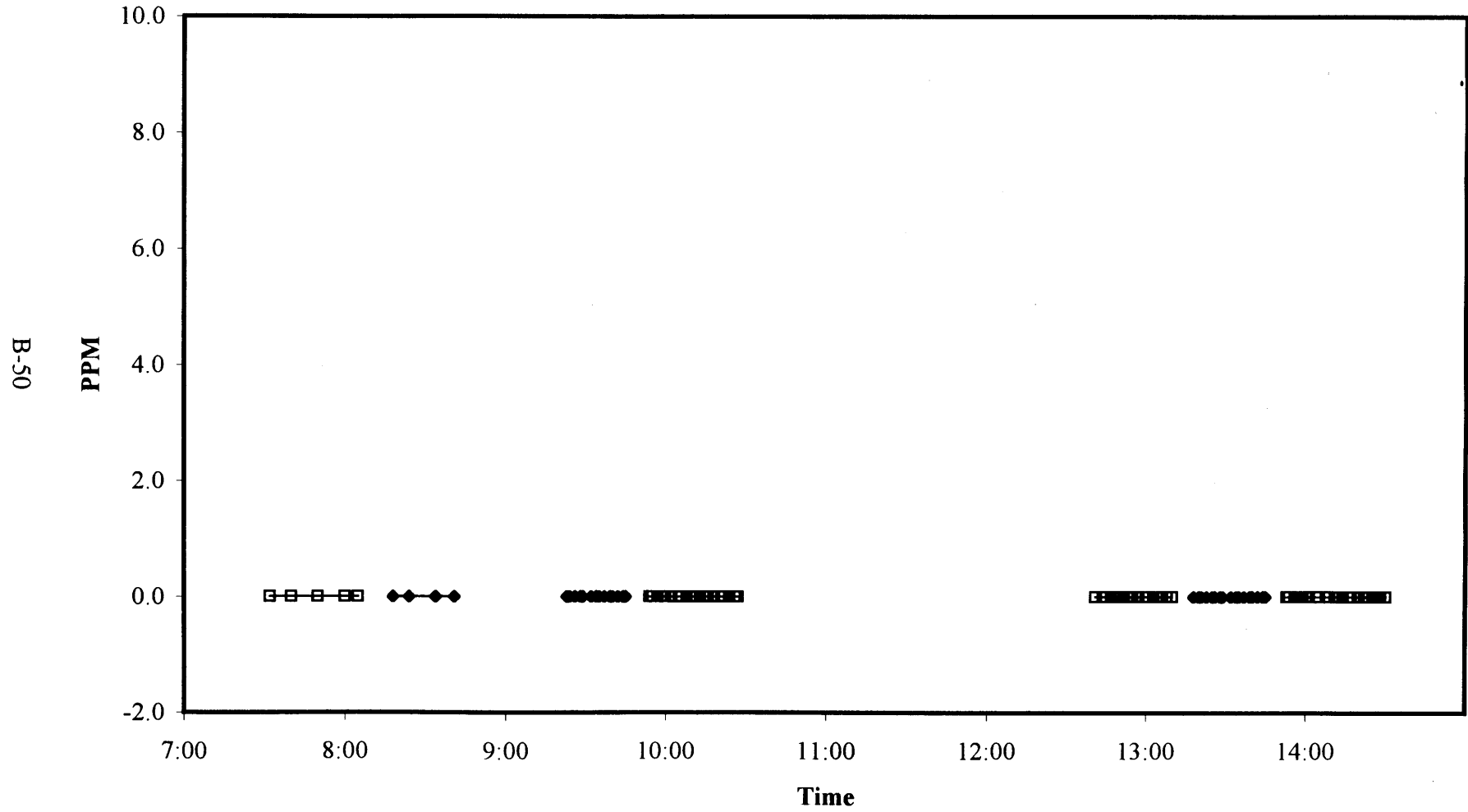
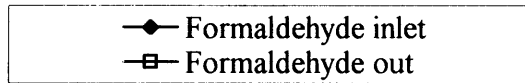

**Baghouse Inlet and Outlet Concentrations vs. Time  
(Untreated Samples). Run 3 - 8/29/97**

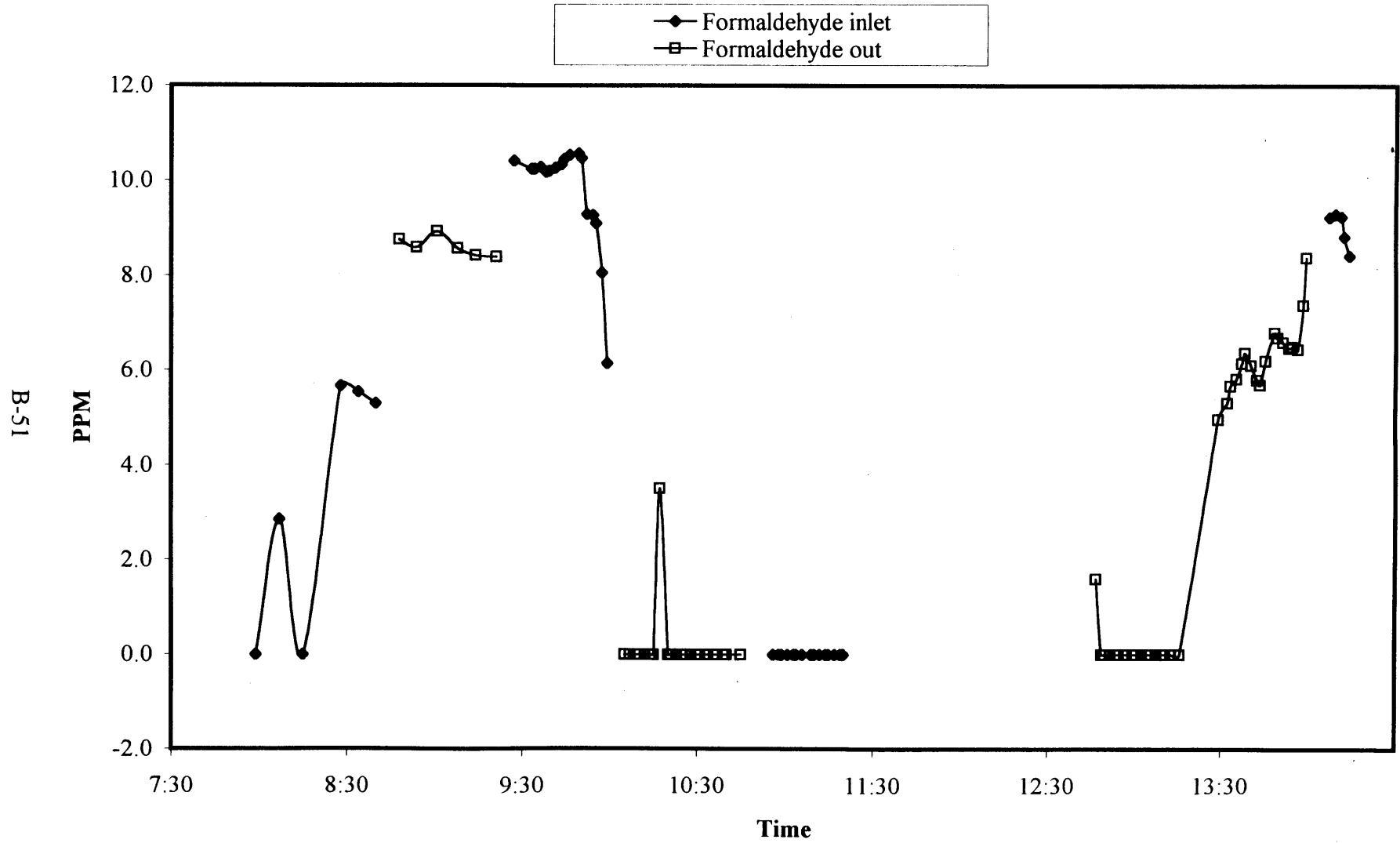



TABLE B-5. PLANT B METHOD DETECTION LIMIT ESTIMATES

Compound	SU <sup>1</sup>	MDL <sup>2</sup> (ppm)
Acetaldehyde	0.19	0.58
Benzene	0.41	1.24
Carbonyl Sulfide	0.01	0.04
Methylchloride	0.61	1.83
Methylchloroform	0.09	0.28
1,1-dichloroethane	0.17	0.50
Toluene	1.27	3.80
1,3-butadiene	0.31	0.93
Methanol	0.10	0.31
Cumene	0.23	0.69
Ethylbenzene	0.00	1.89
Hexane	0.14	0.43
Methylene chloride	0.25	0.76
Propionaldehyde	0.08	0.24
Styrene	0.00	1.28
1,1,2,2-Tetrachloroethane	0.08	0.25
p-Xylene	0.35	1.04
o-Xylene	0.37	1.12
m-Xylene	0.79	2.36
2,2,4-Trimethylpentane	0.04	0.12
Formaldehyde	0.26	0.79

<sup>1</sup> SU = "Statistical Uncertainty" From Proposed ASTM FTIR Method

<sup>2</sup> "Method Detection Limit"

Table B-5 contains results from the "Method Detection Limit" calculation procedure suggested in the September, 1998 version of an FTIR method proposed by the American Society of Testing and Materials (ASTM).

The procedure, briefly, (1) prepares at least 7 spectra with zero analyte concentrations, but with interference absorbances equivalent to the sample spectra, (2) runs the analytical program on these spectra, (3) calculates the standard deviation ("statistical uncertainty," SU) in the results,

and (4) multiplies the SU results by 3 to give the "Method Detection Limit" (MDL)

The spectra in step 1 were prepared in the laboratory as recommended. Seven independent spectra of water vapor (approximately 20 percent), at 124°C, and 753 torr, were measured in a heated cell at a path length of 10 meters. Seven independent spectra of carbon dioxide (CO<sub>2</sub>, 20 percent) were also measured using the same instrument conditions. Seven interference spectra were generated by combining pairs of water vapor and CO<sub>2</sub> spectra. The CO<sub>2</sub> concentrations in the interference spectra were higher than in the sample spectra. The interference spectra moisture concentrations were higher than or equivalent to the sample spectra moisture concentrations.

In step 2 the interference spectra were analyzed using the computer program that was used in the sample analyses. The computer program used reference spectra of moisture and CO<sub>2</sub> that were measured in the laboratory independently of the interference moisture and CO<sub>2</sub> spectra.

The analytical program calculated concentration results for the target analytes in Table B-5. The concentrations were all near zero and the estimated MDL values were determined from the precision of the concentration results for each analyte. The sample test results in Tables B-1 to B-4 were prepared using the same computer program, but the program was constrained to measure only the detected analytes.

The calculation of the "SU" value for a single analyte is given in equation B-1.

$$SU = \sqrt{\frac{1}{(n-1)} \sum_{i=1}^{(n-1)} (C_i - C_M)^2} \quad (B-1)$$

where;

- SU = The "Statistical Uncertainty."
- N = The number of spectra analyzed.
- C<sub>i</sub> = The concentration result from the i<sup>th</sup> spectrum. In this procedure the absolute value of the results was used in equation B-1.
- C<sub>M</sub> = The average of the concentration results for all of the spectra.
- n = The number of measurements. In this case n = 14.

The values "MDL" reported in Table B-5 are equivalent to 3 \* SU for each of the target analytes..

**B-2 FTIR FIELD DATA RECORDS**











## FTIR FIELD DATA FORM

(FTIR Sampling Data)

PROJECT NO. 4701-08-02

BAROMETRIC: \_\_\_\_\_

PLANT: B

DATE: 8/27/97

OPERATOR: T. Geyer

SAMPLE TIME	FILE NAME	PATH		NUMBER SCANS	RES (cm-1)	CELL TEMP (F)	SPIKED/ UNSPIKED	SAMPLE COND.	SAMPLE FLOW	BKG
8:50	REINU101		inlet sample flowing	100	1	115	UN	H/W	3.5 lpm	A
9:02	REOUU101		outlet sample flowing	100/250	1	115	UN	H/W	5 lpm	A
9:43			SF6 spike on to inlet	100/250	1	115	SF6	H/W	2 lpm, VTP = 4.9	A
9:40			Manual runs started							
9:45			Started inlet sample	100/250	1	115	SF6		2 lpm, VTP = 4.8	A
			Spike not working, start sampling while look at where Spike flow is going							
9:55	18270001		first inlet sample	100/250	1	115	UN	H/W	4 lpm	A
10:09	18270007		P=775 torr, process went down							
10:14			process restarted							
10:16			Started SF6 spike to outlet		1	115	S	H/W	SF6 = 3.89 ppm (2.01 lpm)	
10:20	REOUS102	20 passes	Started fill with outlet, P = 766 torr			115	S	H/W	SF6 = 2.01 lpm, sample flow = 4 lpm	
10:27 - 10:31	REOUS103		Started fill with outlet sample	100/250	1	115	S	H/W	SF6 = 2.01 lpm, sample 4.0 lpm	
10:34			Started 101ppm ethylene spike to outlet							
10:37-10:41	REOUS104	20 passes	Outlet spiked with ethylene	100/250	1	115	S	H/W	101 ppm ethylene at 2.01 lpm	
10:42 - 10:46	REOUS105	20 passes	Outlet spiked with ethylene	100/250	1	115	S	H/W	101 ppm ethylene at 2.01 lpm	
10:47	REOUS106	20 passes	101 ppm Ethylene spiked at 2.01 lpm	100/250	1	115	S	H/W	4 lpm	A
10:54			101 ppm ethylene spiked to inlet @ 2.01 lpm							
11:00 - 11:04	REINS102	20 passes	Inlet spiked with ethylene	100/250	1	115	S	H/W	4 lpm, spike 2.01 lpm	A
11:07 - 11:10	REINS103		Inlet spiked with ethylene	100/250	1	115	S	H/W	4 lpm, spike 2.01 lpm	
11:13 - 11:16	REINS104		Inlet spiked with ethylene	100/250	1	115	S	H/W	4 lpm, spike 2.01 lpm	
11:17			Switched to SF6 spike @ 2.01 lpm to inlet							
11:20/11:15			5 minute time shift to match							
11:15-11:17	REAINS105		3.89 ppm SF6 spike at 2.01 lpm	100	1	118	S	H/W	4 lpm	A
11:23	REAINS106		3.89 ppm SF6 spike at 2.01 lpm							
11:39	18270008		Outlet sample	100	1	118	UN	H/W	4 lpm	A
11:41			Process down							
11:46			Process up							
	18270012		First good sample							
12:16	18270027		Final outlet sample							

B-60







# FTIR FIELD DATA FORM

(FTIR Sampling Data)

PROJECT NO. 4701-08-02

BAROMETRIC:

PLANT: B

DATE: 8/29/97

OPERATOR: T. Geyer

SAMPLE TIME	FILE NAME	PATH		NUMBER SCANS	RES (cm-1)	CELL TEMP (F)	SPIKED/ UNSPIKED	SAMPLE COND.	SAMPLE FLOW	BKG
7:54 - 7:58	REINS301	20 passes	Inlet spiked with SF6 @ 2.01 lpm P = 769 torr	100/250	1	114	S/SF6	H/W	4 lpm	B
8:04 - 8:08	REINS302	20 passes	Inlet spiked with SF6 @ 2.01 lpm	100/250	1	114	S/SF6	H/W	4 lpm	B
8:11 - 8:14	REINS303	20 passes	Inlet spiked with SF6 @ 2.01 lpm	100/250	1	114	S/SF6	H/W	4 lpm	B
8:17			Start inlet ethylene spike at 2 lpm							
8:26	REINS304	20 passes	Inlet ethylene	100/250	1	114	S/ethylene	H/W	4 lpm	B
8:33	REINS305	20 passes	Inlet ethylene	100/250	1	114	S/ethylene	H/W	4 lpm	B
8:40	REINS306	20 passes	Inlet ethylene	100/250	1	114	S/ethylene	H/W	4 lpm	B
8:43			Ethylene spike on to outlet/ spike off at inlet							
8:45 - 8:48	REOUS301		Outlet spiked with ethylene	100/250	1	115	S/ethylene	H/W	4 lpm	B
8:51 - 8:55	REOUS302		Outlet spiked with ethylene	100/250	1	115	S/ethylene	H/W	4 lpm	B
9:00 - 9:03	REOUS303		Outlet spiked with ethylene	100/250	1	115	S/ethylene	H/W	4 lpm	B
9:03			started SF6 spike to outlet/ ethylene spike off							
9:06 - 9:10	REOUS304		Outlet sample spiked with SF6 @ 2.01 lpm	100/250	1	115	S	H/W	4 lpm	B
9:12 - 9:16	REOUS305		Outlet sample spiked with SF6 @ 2.01 lpm	100/250	1	115	S	H/W	4 lpm	B
9:18 - 9:22	REOUS306		Outlet sample spiked with SF6 @ 2.01 lpm	100/250	1	115	S	H/W	4 lpm	B
9:22			SF6 spike off at outlet							
9:24			go to hot/wet sampling at inlet							
9:24 - 9:28	REINU307	20 passes	inlet sample	100/250	1	115	U	H/W	4 lpm	B
9:32	18290001	20 passes	first continuous inlet sample	100/250	1	115	U	H/W	4 lpm	B
10:00	18290016		Last inlet sample	100/250	1	115	U	H/W	4 lpm	B
10:03			Started fill with outlet sample							
10:05	18290018	20 passes	first good outlet sample	100/250	1	115	U	H/W	4 lpm	B
10:41	18290038	20 passes	last outlet sample	100/250	1	115	U	H/W	4 lpm	B
10:49	REOUU307		Outlet unspiked to verify test hydrocarbon's concentrations have dropped.							B
10:52	18290049	20 passes	Started to fill with inlet sample							
			inlet sample H/W	100/250	1	115	U	H/W	4 lpm	B
10:20			the process was changed - this change coincides with the observed drop in THC; hydrocarbon, and CO in FTIR , increase in moisture							

B-64



## FTIR FIELD DATA FORM

(FTIR Sampling Data)

PROJECT NO. 4701-08-02

BAROMETRIC:

PLANT: B

DATE: 8/29/97

OPERATOR: T. Geyer

SAMPLE TIME	FILE NAME	PATH		NUMBER SCANS	RES (cm-1)	CELL TEMP (F)	SPIKED/ UNSPIKED	SAMPLE COND.	SAMPLE FLOW	BKG
11:23	1829053		Last inlet sample	100/250	1	115	U	H/W	4 lpm	B
11:25			Start outlet through Conditioner							
11:29	1821056		first good outlet sample	100/250	1	115	U	Cond	4 lpm	B
			Computer clock is about 1 hr slow							
12:00	18290073		last outlet sample	100/250	1	115	U	Cond	4 lpm	B
12:03			Started filling with inlet sample							
12:07	18290075		Inlet		1	115	U	Condenser	4 lpm	B
12:11	18290078		Process down							
12:21	18290082		Kiln back on line							
12:40	18290093		Last inlet sample	100/250	1	115	U	Condenser	4 lpm	B
			P= 760 torr							
			Cell inlet valves may have been closed during this period							
			so samples (0073 - 0093) may not be good							
12:42			Process down							
12:44			Started fill with outlet	100/250	1	115	U	H/W		
12:46	18290094		first outlet spectrum	100/250	1	115	U	H/W	4 lpm	B
13:16	182900111		Last outlet sample, process is still down							
13:24			Kiln is back on line							
13:29			Start fill with outlet							
13:31	18290112	20 passes	first outlet sample	100/250	1	115	U	H/W		C
14:00	18290129	20 passes	last outlet sample	100/250	1	115	U	H/W	5 lpm	C
14:01			start fill with inlet							
14:07	18290132		first inlet sample	100/250	1	115	U	H/W	5 lpm	C
14:13	18290136		Last good outlet sample							

B-65



Date	Time	File Name	Path	Location/Notes	#scans	Res (cm-1)	Cell temp (F)	Pressure <sup>mm Hg</sup>	BKG	Apod
8/26/97	13:00			System set up and leak checked then using the longest (2.3 mm) path length cell because we got no throughput at the medium (1.5 mm) cell the 1.5 mm would be better for 1 cm <sup>-1</sup> resolution. So there may be some degradation of the resolution.  Path length set @ 20 passes through the cell (~10 meters)						
8/27/97	8:11	BKG0827A	20 passes	101 ppm ethylene in air		1.0	115C	766		NB/acc
"	8:37	CT50827A	"	101 ppm ethylene in air A.011020008		"	"	770	A	"
8/27/97	15:32	<del>CT50827A</del>	20 passes	3.89 ppm SO <sub>2</sub>	100	1.0	115	767	A	
8/27/97	15:37		20	101 ppm ethylene	100	1.0	115	767	A	
	16:07	NITR08		N <sub>2</sub> through well anderson						

B-67

Date	Time	File Name	Path	Location/Notes	#scans	Res (cm-1)	Cell temp (F)	Pressure	BKG	Apod
8/28/97	705	BK60828a	2op	N <sub>2</sub> through cell @ 2 lpm	250	1.0	115	772	-	NB/mid
8/28/97	710	CT50828a	0cp	Ethylene through cell @ 2 lpm	100	1.0	115	765	A	NB/mid
	725			good leak check on cell						
	725									
	726			M 25A is on line						
				SFA spike read + let @ 2.0 lpm						
				359 ppm SF <sub>6</sub>						
	857			Purging w/ N <sub>2</sub> for New Background						
	901			Process Down						
	908			Kidn Back on						
	911	BK60828B	2op	N <sub>2</sub> through cell	250	1.0	115	765	-	NB/mid
				some residual hydrocarbons						
				come through the line for background						
	913	EVAC2001	2op	spectrum of evacuated cell	100					
	1516	NIT2000	2op	Nitrogen thru cell @ 2 lpm	100	1.0	115	763	B	NB/mid
				cell background						
				small amount of residual hydrocarbons						
	1418	RES2000C	2op	N <sub>2</sub> thru cell @ 2 lpm	250	1.0	115	762	-	NB/mid
	1502	1530828	2op	Toluene @ 2 lpm	100	1.0	115	760	C	NB/mid
	1512	CT50828a	2op	Ethylene @ 2.0 lpm	100	1.0	115	762	C	NB/mid

B-68

Date	Time	File Name	Path	Location/Notes	#scans	Res (cm-1)	Cell temp (F)	Pressure	BKG	Apod
8/24/97	643	BK60829A	Top	N <sub>2</sub> through cell	250	1.0	115	761	-	MS/line
	650	CTS0829A	"	101 ppm ethylene in air	100/250	1.0	115	762	A	"
	705	NT13001	"	N <sub>2</sub> through cell showing no band	100/250	1.0	115	769	A	"
	746	BK60829B	"	N <sub>2</sub> through cell @ 3.6 lpm 3.6 lpm	<del>100</del> 250	1.0	115	770	-	"
	1321	BK60829C	"	N <sub>2</sub> through cell @ 3.6 lpm	450	1.0	115	769	-	"
				Did not pass inlet location back check to make it run.						
				Fixed angle as fitting and run passed back check.						
	1430	BK60829D	"	N <sub>2</sub> through cell @ 2.0 lpm	250	1.0	115	763	-	"
	1440	SF60829A	2ep	560 3.89 ppm ethylene cell	100/250			764	D	"
	1446	CTS0829B		@ 2.0 lpm						
				→ 101 ppm ethylene @ 2.0 lpm through cell	100/250	1.0	115	764	D	"

B-69

*J. Guy*

Date	Sample time	File name	Path	Location/Notes	#scans	Res (cm-1)	Cell Temp (F)	Spk/Unsp	Sample Cond	Sample Flow	BKG
5/27/47	3:50	REC12101		inlet sample, flowing	100	1.0	115	UN	H/W	3.5 lpm	A
"	9:02	REC12101		outlet sample flowing	100/250	1.0	115	UN	H/W	3.5 lpm	A
	<del>9:43</del>			SFA spike on inlet							
	<del>9:50</del>			<del>inlet</del>							
	<del>9:50</del>			<del>inlet</del>	100/250	1.0	115	SFC	H/W	VIP = 4.8 2.2 lpm	A
	9:40			manual Runs started							
	9:45			spiked inlet sample	100/250	1.0	115	SFC		VIP = 4.8 2.2 lpm	A
				Spike not working start sampling while taking a break Spike flow is going							
	9:55	1827007		1827001 first inlet sample	100/250	1.0	115	UN	H/W	4 lpm	A
	10:09	1827007 (during)		process went down							
	10:14			Process restarted							
	10:16			started fill with inlet sample						SFC (3.89 lpm)	
	10:17			started SFA spike to outlet		1.0	115	S	H/W	2.01 lpm	
P=776	10:20	REC12104		started fill with outlet sample			115	Sp	H/W		
				Sample flow 4 lpm				SFC	2.01 lpm		
				This is an outlet sample it inlet!!! - retained spectrum C of time.							
	10:27	REC12103		started fill with outlet sample	100/250	1.0	115	S	H/W	SFC 2.01 lpm	A
	10:34			started 2 lpm						sample 4 lpm	
	10:37	REC12104		started fill with outlet sample	100/250	1.0	115	S	H/W	1.01 lpm	A
	10:42	REC12105		outlet spike is ethylene	100/250	1.0	115	S	H/W	2.01 lpm	A

B-70

Date	Sample time	File name	Path	Location/Notes	#scans	Res (cm-1)	Cell Temp (F)	Spk/Unsp	Sample Cond	Sample Flow	BKG
8/27/17	1047	REINS100	204	101 ppm Ethylene spike @ 2.01 Lpm	100/250	1.0	115	S	H/W	4 Lpm	A
	1057			101 ppm Ethylene spike @ 2.01 Lpm							
1059-1104		REINS102	204	101 ppm Ethylene spike @ 2.01 Lpm	100/250	1.0	115	S	H/W	1.0 Lpm, spike 2.01 Lpm @	
1107-1110		REINS103		"							
1113-1116		REINS104		"							
1117				switched to st. spike @ 2.01 Lpm							
1180/1183-1189		REINS105		389 ppm x6 spike @ 2.01 Lpm	100	1.0	118	S	H/W	4 Lpm	A
1135		18270008		Outlet Sample	100	1.0	118	U	H/W	4 Lpm	A
1141				Process down							
1146				Process up							
1146		18270012		First blank sample							
1146		18270027		Final outlet sample							
1218		18270030		Final sample	100	1.0	118	U	H/W	4 Lpm	A
1248		18270045		Final outlet sample							
1256		18270047		Outlet sample	100	1.0	115	U	C/D	4 Lpm	A
1320		18270061		Final outlet sample							
1330		18270064		Inlet Sample	100	1.0	117	U	C/D	4 Lpm	A
1419		18270080		Final inlet sample							
1403		18270082		Outlet Sample	100	1.0	115	U	H/W	4 Lpm	A
1419				Process down							
1419				Process up							
1414		18270088		Core leak in outlet filter box near skid system pass							
1444		18270094		logged outlet sample filter was @ 125 F. Reconnected @ 1431							
1446				Start inlet sample							
1448		18270098		first good inlet spectrum							
1519		18270115		best yet inlet spectrum							

run difference by Tom's work

B-71

single cell

D heet: FTIR Samples:

EPA Work Assignment 4-

Date	Sample time	File name	Path	Location/Notes	#scans	Res (cm-1)	Cell Temp (F)	Spk/Unsp	Sample Cond.	Sample Flow	BKG
8/29/01	731	REA0522	20p	outlet spike w/ STG	100/250	1.0	115	5	H/W		A
	737	REA0522	20p	Mix. Mixture of PES uparts	~	31%	moisture				
	740	REA0522	20p	outlet spike w/ STG	100/250	1.0	115	5	H/W	H	A
	753			outlet spike w/ STG	100/250	1.0	115	5	H/W	H	A
	759	REA0522	20p	start toluene spike @	2.01	2 ppm					
	803	REA0522	20p	outlet spike w/ toluene	100/250	1.0	118	5	H/W	H	A
	803	REA0522	20p	"	100/250	1.0	118	5	H/W	H	A
	816	REA0522	20p	start spike toluene @ inlet	2.01	2 ppm					
	823	REA0522	20p	inlet spike w/ toluene	100/250	1.0	118	5	H/W	H	A
	823	REA0522	20p	"	100/250	1.0	115	5	H/W	H	A
	837			start inlet STG spike @	2.01	2 ppm					
	838	REA0522	20p	inlet spike STG	100/250	1.0	115	5	H/W	H	A
	841	REA0522	"	"	"	"	"	"	"	"	"
	921		start fill	start condenser inlet sample	100/250	1.0	115	11	H/W	4.2 ppm	B
	921									11	
	922	18280001		first inlet spectrum	100/250	1.0	115	11	H/W	5.1 ppm	B
	948	18280014		last inlet spectrum	100/250						B
	952	18280016		first outlet spectrum							B
		18280035		last outlet sample							B
	1036			started inlet sample through condenser							
	1041	182800205		inlet inlet sample	100/250	1.0	115	11	Condenser	4.1 ppm	B
	1046	18280036		first condenser inlet spectrum	"	1.0	115	11	Condenser	4.5 ppm	B
	1111	18280050		last inlet sample							B
	1111			Process down - change condenser filter @ inlet spike							

B-72



Process  
still  
down →

B-73

Date	Sample time	File name	Path	Location/Notes	#scans	Res (cm-1)	Cell Temp (F)	Spk/Unsp	Sample Cond	Sample Flow	BKG
8/28/17	1113			Renewed Condenser injection							
				stand outlet sample through Condenser							
	1117	18280055	24	first outlet spectrum through Condenser	100/250	1.0	115	u	Cond	4.6pm	B
	1122			Process Backup							
	1123	18280056		first outlet sample after Process Backup	100/250	1.0	115	u	Cond	4.5pm	B
	1153	18280073		last outlet spectrum							
	1240	18280076		First Inlet sample	100/250	1.0	115	u	Cond	5.8pm	B
	1223	18280093		Last Inlet sample	100/250	1.0	115	u	Cond	5.8pm	B
	1240	18280096		First Outlet sample	100/250	1.0	115	u	H/w	4.8pm	B
	1310	18280110		Last Outlet sample	100/250	1.0	115	u	H/w	4.8pm	B
	1315	18280115		First Inlet sample	100/250	1.0	115	u	H/w	5.8pm	B
	1346	18280131		Last Inlet sample	100/250	1.0	115	u	H/w	5.8pm	B
	1350	1820134		first Outlet sample	100/250	1.0	115	u	H/w	4.8pm	B
	1355	1820135		Process down / last inlet sample							
	1407	1820143		first sample after Process backup	"	"	"	"	"	"	"
	1432	1820134		Last Outlet sample							

*JG*

Through cell

D-769

B-74

Date	Sample time	File name	Path	Location/Notes	#scans	Res (cm-1)	Cell Temp (F)	Spk/Unsp	Sample Cond	Sample Flow	BKG
8/24/91	754-818	REINS301	20p	inlet spiked w/ SFw @ 2.01 lpm	100/250	1.0	114	S/G	H/W	4.0 lpm	B
	804-808	REINS302									
	811-814	REINS323	dep	"	"	"	"	"	"	"	"
	817			inlet Inlet Ethylene spike @ 2 lpm							
	820	REINS24	dep	Inlet Styrene	100/250	1.0	114	S/G	H/W	4.0 lpm	B
	833	REINS25	dep	"	"	"	"	"	"	"	"
	840	REINS26	"	"	"	"	"	"	"	"	"
	843			ethylene spike to outlet / spike off @ inlet							
	845-849	REINS30		inlet spiked with ethylene	100/250	1.0	115	S/G	H/W	4.0 lpm	B
	851-855	REINS302									
	900-903	REINS33									
	903			started SFw spike to outlet / ethylene spike off							
	906-910	REINS304		Outlet sample spiked w/ SFw @ 2.01 lpm	100/250	1.0	115	S/G	H/W	4.0 lpm	B
	912-916	REINS305									
	918-922	REINS306									
	922			SFw spike off @ outlet							
	924			go to hot fluid sampling @ inlet							
	928-928	REINS307	20p	inlet sample	100/250	1.0	115	LL	H/W	4.0 lpm	B
	932	18270001	20p	first butanone inlet sample	100/250	1.0	115	LL	H/W	4.0 lpm	B
	1000	18270016		last inlet sample							

Date	Sample time	File name	Path	Location/Notes	#scans	Res (cm-1)	Cell Temp (F)	Spk/Unsp	Sample Cond.	Sample Flow	BKG
8/29/07	1003			stuck full with outlet sample							
Spk/Unsp →	1005	18290018	20g	first good outlet sample	100/250	1.0	115	U	H/W	4.0pm	B
	1041	18290038		lost outlet sample							
	1044	R5000307		outlet unexpected to verify test hydrocarbons concentrations have dropped.							B
	1052	18290099	20g	started to fill with inlet sample							
			20g	inlet sample H/W	100/250	1.0	115	U	H/W	4.0pm	B
	1020			The process was changed - this change coincides with the observed drop in THC, and hydrocarbons CO in FTIR and decrease in CO, increase in moisture							
	1723	1829053		lost inlet sample	100/250	1.0	115	U	H/W	4.0pm	B
	1751	1829053		start outlet min conditioner							
	1129	1829056		first good outlet sample	100/250	1.0	115	U	Cond.	4.0pm	B
			Cond.	Check in ~ 1 hr slow							
	1200	18290073		last outlet sample	100/250	1.0	115	U	Cond.	4.0pm	B
	1203			started filling with inlet sample					Condenser		
	1207	18290075		inlet		1.0	115	U	Condenser	4.0pm	B
	1211	18290078		process down							
	1221	18290082		kill back on line							
	1240	18290093		last inlet sample	100/250	1.0	115	U	Condenser	4.0pm	B
	1242			process down							
	1244			started full with outlet	100/250	1.0	115	U	H/W		
	1246	18290094		just outlet spectrum	100/250	1.0	115	U	H/W	4.0pm	B
	1316	18290111		last outlet sample							
	1324			kill back on line							

B-75  
 Cell and pt  
 25.0mm  
 from 1 to 100  
 dec  
 may not  
 cond  
 P = 760  
 torr  
 may not  
 cond  
 (0573)



**B-3 FTIR FLOW AND TEMPERATURE READINGS**











4701-08-02-03

**FTIR FIELD DATA FORM**

PROJECT NO. 3804-24 PLANT:           

DATE: 8/29/97

BAROMETRIC: 762 torr

INLET					
CLOCK TIME	DELTA P IN. H2O	STACK TEMP.	PROBE TEMP.	PROBE BOX TEMP.	
758	<del>1.1</del>	311	305	302	
	1.1				
835	1.1	312	303	304	
916	0.68	299	304	304	
936	1.6	301	305	303	
1004	<del>1.8</del>	298	302	304	
	0.75	<del>29</del>			
1026	0.61	273	303	302	
1055	0.70	298	303	301	
1109	0.82	299	303	300	
1134	1.4	283	303	303	
1153	1.4	287	304	301	
1208	0.88	292	303	299	
1243	0.60	322	303	305	
1242-1324		Process down			
1326	0.1	374	302	300	
1332	0	295	302	305	
1400	0.48	315	304	301	

OUTLET					
CLOCK TIME	DELTA P IN. H2O	STACK TEMP.	PROBE TEMP.	PROBE BOX TEMP.	
753	not in recording	251	304	303	
835	-	292	304	302	
916	-	276	302	304	
936	-	278	304	302	
1004	-	275	304	302	
1026	-	262	304	301	
1055	-	274	304	302	
1109	-	275	304	303	
1134	-	265	304	301	
1153	-	265	305	302	
1208	-	269	304	301	
1243	-	292	304	300	
1326	-	259	303	300	
1332	-	271	304	304	
	-	285	305	304	

Process start  
Furnace leak  
one connection was not complete

B-82

Recorder  
OPERATOR: J. Geyer

APPENDIX C

EQUIPMENT CALIBRATION CERTIFICATES



**C-1 CALIBRATION GAS CERTIFICATES**





213-685-2184  
FAX 213-685-2622

# LIQUID CARBONIC

CYLINDER GAS PRODUCTS

5700 SOUTH ALAMEDA STREET • LOS ANGELES, CA 90088

## CERTIFICATE OF ANALYSIS / EPA PROTOCOL GAS

CUSTOMER ENV. & INDUST. DIST.

P.O NUMBER 80110932 82:032295-1

### REFERENCE STANDARD

COMPONENT

NIST SRM NO.

CYLINDER NO.

CONCENTRATION

PROPANE

GH18

vs 2649

SA 7651

5019 ppm

### ANALYZER READINGS

R = REFERENCE STANDARD

Z = ZERO GAS

C = GAS CANDIDATE

1. COMPONENT	PROPANE	GH18	ANALYZER MAKE-MODEL-S/N	HP 5890 SERIES 11	S/N 3310A48533
ANALYTICAL PRINCIPLE	GC/ PLAME IONIZATION			LAST CALIBRATION DATE	03/28/95
FIRST ANALYSIS DATE	04/07/95			SECOND ANALYSIS DATE	
Z 0	R 2607832	C 2744825	CONC. 5283 ppm	Z	R C CONC.
R 2612210	Z 0	C 2745146	CONC. 5274 ppm	R	Z C CONC.
Z 0	C 2737157	R 2602984	CONC. 5278 ppm	Z	C R CONC.
U/M W-s		MEAN TEST ASSAY	5278 ppm	U/M W-s	MEAN TEST ASSAY

Values not valid below 150 psig

THIS CYLINDER NO.	SA 8458	CERTIFIED CONCENTRATION
MAS BEEN CERTIFIED ACCORDING TO SECTION	EPA-600/R93/224	PROPANE 5278 ppm
OF TRACEABILITY PROTOCOL NO.	Rev. 9/93	NITROGEN BALANCE
PROCEDURE	61	
CERTIFIED ACCURACY	± 1 % NIST TRACEABLE	
CYLINDER PRESSURE	2000 PSIG	
CERTIFICATION DATE	04/07/95	
EXPIRATION DATE	04/07/98 TERM 36 MONTHS	

ANALYZED BY

CERTIFIED BY

DAN T. YOUNG



818-488-2184  
FAX 818-488-0882

**LIQUID CARBONIC**  
CYLINDER GAS PRODUCTS  
5700 SOUTH ALAMEDA STREET • LOS ANGELES, CA 90068

**CERTIFICATE OF ANALYSIS / EPA PROTOCOL GAS**

CUSTOMER ENV. & INDUST. DIST.

P.O NUMBER 80110932 RE:032295-1

**REFERENCE STANDARD**

COMPONENT		NIST SER. NO.		CYLINDER NO.		CONCENTRATION
PROPANE	GH18	vs 2649		SA 7651		5019 ppm

**ANALYZER READINGS**

R = REFERENCE STANDARD      Z = ZERO GAS      C = GAS CANDIDATE

1. COMPONENT	PROPANE	GH18	ANALYZER MAKE-MODEL-SN	HP 5890 SERIES II	S/N J310A48933		
ANALYTICAL PRINCIPLE	GC/ FLAME IONIZATION			LAST CALIBRATION DATE	03/28/95		
FIRST ANALYSIS DATE	04/07/95			SECOND ANALYSIS DATE			
Z 0	R 2607332	C 2744525	CONC. 5283 ppm	Z	R	C	CONC.
R 2612210	Z 0	C 2745146	CONC. 5274 ppm	R	Z	C	CONC.
Z 0	C 2737157	R 2602984	CONC. 5278 ppm	Z	C	R	CONC.
U/M	W-S	MEAN TEST ASSAY	5278 ppm	U/M	W-S	MEAN TEST ASSAY	

Values not valid below 150 psig

THIS CYLINDER NO.	SA 8458	CERTIFIED CONCENTRATION
HAS BEEN CERTIFIED ACCORDING TO SECTION	EPA-600/R93/224	PROPANE 5278 ppm
OF TRACEABILITY PROTOCOL NO.	Rev. 9/93	NITROGEN
PROCEDURE	61	BALANCE
CERTIFIED ACCURACY	± 1 % NIST TRACEABLE	
CYLINDER PRESSURE	2000 PSIG	
CERTIFICATION DATE	04/07/95	
EXPIRATION DATE	04/07/98	TERM 36 MONTHS

ANALYZED BY *Wanda...*

CERTIFIED BY *JOHN T. YOUNG*





# Scott Specialty Gases

Shipped  
From:

6141 EASTON ROAD  
PLUMSTEADVILLE  
Phone: 215-766-8861

PO BOX 310  
PA 18949-0310

Fax: 215-766-2070

## CERTIFICATE OF ANALYSIS

MIDWEST RESEARCH  
TOM GEYER  
425 VOLKER BLVD

KANSAS CITY

MO 64110

PROJECT #: 01-88514-001  
PO#: 029257  
ITEM #: 01021951 LAL  
DATE: 3/25/97

CYLINDER #: ALM023940  
FILL PRESSURE: 2000 PSIG  
BLEND TYPE : GRAVIMETRIC MASTER GAS

ANALYTICAL ACCURACY: +-1%

COMPONENT	REQUESTED GAS		ANALYSIS	
	CONC MOLES		(MOLES)	
ETHYLENE	20.	PPM	20.01	PPM
NITROGEN		BALANCE		BALANCE

CERTIFIED

ANALYST: *G. Rogut*  
GENYA ROGUT



# Scott Specialty Gases

Shipped  
From:

6141 EASTON ROAD  
PLUMSTEADVILLE  
Phone: 215-766-8861

PA 18949-0310

PO BOX 310

Fax: 215-766-2070

## CERTIFICATE OF ANALYSIS

MIDWEST RESEARCH  
DAVE ALBURTY, X1525  
425 VOLKER BLVD

KANSAS CITY

MO 64110

PROJECT #: 01-89796-005  
PO#: 029872  
ITEM #: 01023912 4AL  
DATE: 5/13/97

CYLINDER #: ALM057730  
FILL PRESSURE: 2000 PSIG  
BLEND TYPE : CERTIFIED MASTER GAS

ANALYTICAL ACCURACY: +/- 2%

COMPONENT  
TOLUENE  
AIR

REQUESTED GAS  
CONC MOLES  
120. PPM  
BALANCE

ANALYSIS  
(MOLES)  
121. PPM  
BALANCE

**CERTIFIED**

ANALYST:

G. Rogut  
GENYA ROGUT



# Scott Specialty Gases

Shipped From: 1290 COMBERMERE STREET  
 TROY MI 48083  
 Phone: 248-589-2950

Fax: 248-589-2134

## CERTIFICATE OF ANALYSIS

MIDWEST RESEARCH  
 MELISSA TUCKER; # 026075  
 425 VOLKER BLVD

PROJECT #: 05-97268-002  
 PO#: 026075  
 ITEM #: 05023822 4A  
 DATE: 6/03/96

KANSAS CITY MO 64110

CYLINDER #: A7853  
 FILL PRESSURE: 2000 PSI

ANALYTICAL ACCURACY: +/- 2%  
 PRODUCT EXPIRATION: 6/03/1997

BLEND TYPE : CERTIFIED MASTER GAS

COMPONENT  
 SULFUR HEXAFLUORIDE  
 NITROGEN

REQUESTED GAS  
CONC MOLES  
 4. PPM  
 BALANCE

ANALYSIS  
(MOLES)  
 4.01 PPM  
 BALANCE

CERTIFIED MASTER GAS

ANALYST:

*Amah Reister*

C-7



# Scott Specialty Gases, Inc.

Shipped From: 6141 EASTON ROAD  
 PLUMSTEADVILLE PA 18949-0310 PO BOX 310  
 Phone: 215-766-8861 Fax: 215-766-2070

## CERTIFICATE OF ANALYSIS

MIDWEST RESEARCH  
 PO#014952  
 425 VOLKER BLVD

PROJECT #: 01-59176-001  
 PO#: 014952  
 ITEM #: 01021912 2AL  
 DATE: 7/20/94

KANSAS CITY MO 64110

CYLINDER #: ALM020008 ANALYTICAL ACCURACY: +/-1%

BLEND TYPE : ACUBLEND MASTER GAS

COMPONENT	REQUESTED GAS		ANALYSIS	
	CONC MOLES		(MOLES)	
ETHYLENE	100.	PPM	101.	PPM
AIR		BAL		BAL

**CERTIFIED**

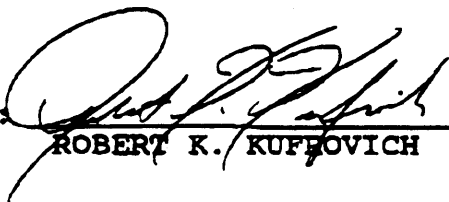
ANALYST:   
 ROBERT K. KUPROVICH



# Scott Specialty Gases

Shipped  
From:

6141 EASTON ROAD  
PLUMSTEADVILLE  
Phone: 215-766-8861

PA 18949-0310

PO BOX 310

Fax: 215-766-2070

## C E R T I F I C A T E O F A N A L Y S I S

MIDWEST RESEARCH

CROSSROADS CORP PARK  
5520 DILLARD RD, SUITE 100  
CARY

NC 27511

PROJECT #: 01-08674-002

PO#: A035678

ITEM #: 01021912 2AL

DATE: 9/22/98

CYLINDER #: ALM020008  
FILL PRESSURE: 400 PSIG

ANALYTICAL ACCURACY: +\ -2%

BLEND TYPE : ACUBLEND MASTER GAS

COMPONENT

ETHYLENE  
AIR

REQUESTED GAS  
CONC MOLES

100. PPM  
BALANCE

ANALYSIS  
(MOLES)

101. PPM  
BALANCE

ANALYST:

GENYA KOGUT



C-2 ENVIRONICS MASS FLOW METER CALIBRATIONS





ENVIRONICS FLOW CONTROLLER CALIBRATION SHEET

Mf #: 2, Description: AIR, Size: 10000, SCCM, K-factor: 1.0

SERIAL # AW9502157

This flow controller was calibrated using a Sierra Cal Bench(TM), a traceable Primary Flow Standard Calibration System. This calibration is referenced to dry air at a temperature of 32F (\_\_\_C) and a pressure of 29.92 in.Hg (760Torr).

	Set Flow	True Flow
5 %	500.0 CCM	510.51 CCM
10 %	1000.0 CCM	1021.4 CCM
20 %	2000.0 CCM	2046.9 CCM
30 %	3000.0 CCM	3074.8 CCM
40 %	4000.0 CCM	4103.8 CCM
50 %	5000.0 CCM	5136.6 CCM
60 %	6000.0 CCM	6156.8 CCM
70 %	7000.0 CCM	7182.5 CCM
80 %	8000.0 CCM	8203.3 CCM
90 %	9000.0 CCM	9219.5 CCM
100%	10000. CCM	10233. CCM

Calibration data was last saved on Friday 03 January 97 at 17:09:00

Verified by: Karl Sentuary Date: 1 - 3 - 97

ENVIRONICS FLOW CONTROLLER CALIBRATION SHEET

Mf #: 4, Description: AIR, Size: 100.0 SCCM, K-factor: 1.0

SERIAL # AW9612049

This flow controller was calibrated using a Sierra Cal Bench(TM), a traceable Primary Flow Standard Calibration System. This calibration is referenced to dry air at a temperature of 32F (\_\_\_C) and a pressure of 29.92 in.Hg (760Torr).

	Set Flow	True Flow
5 %	5.0 CCM	5.236 CCM
10 %	10.0 CCM	10.269 CCM
20 %	20.0 CCM	20.434 CCM
30 %	30.0 CCM	30.524 CCM
40 %	40.0 CCM	40.606 CCM
50 %	50.0 CCM	50.636 CCM
60 %	60.0 CCM	60.683 CCM
70 %	70.0 CCM	70.779 CCM
80 %	80.0 CCM	80.917 CCM
90 %	90.0 CCM	91.035 CCM
100%	100.0 CCM	101.12 CCM

Calibration data was last saved on Friday 03 January 97 at 19:11:00

Verified by: Karl Sentiany Date: 1 - 3 - 97

S/N 2073

ENVIRONICS FLOW CONTROLLER CALIBRATION SHEET

Mf #: 1, Description: AIR, Size: 10000. SCCM, K-factor: 1.0

SERIAL # AW9502156

This flow controller was calibrated using a Sierra Cal Bench(TM), a traceable Primary Flow Standard Calibration System. This calibration is referenced to dry air at a temperature of 32F (\_\_\_C) and a pressure of 29.92 in.Hg (760Torr).

	Set Flow	True Flow
5 %	500.0 CCM	498.79 CCM
10 %	1000.0 CCM	1009.0 CCM
20 %	2000.0 CCM	2029.8 CCM
30 %	3000.0 CCM	3058.2 CCM
40 %	4000.0 CCM	4088.8 CCM
50 %	5000.0 CCM	5121.9 CCM
60 %	6000.0 CCM	6143.3 CCM
70 %	7000.0 CCM	7178.3 CCM
80 %	8000.0 CCM	8206.3 CCM
90 %	9000.0 CCM	9224.6 CCM
100%	10000. CCM	10252. CCM

Calibration data was last saved on Friday 03 January 97 at 16:22:00

Verified by: Karl Sentiary Date: 1 - 3 - 97

ENVIRONICS FLOW CONTROLLER CALIBRATION SHEET

Mf #: 3, Description: AIR, Size: 1000.0 SCCM, K-factor: 1.0

SERIAL # AW9502153

This flow controller was calibrated using a Sierra Cal Bench(TM), a traceable Primary Flow Standard Calibration System. This calibration is referenced to dry air at a temperature of 32F (\_\_\_C) and a pressure of 29.92 in.Hg (760Torr).

	Set Flow	True Flow
5 %	50.0 CCM	50.515 CCM
10 %	100.0 CCM	101.84 CCM
20 %	200.0 CCM	204.84 CCM
30 %	300.0 CCM	306.67 CCM
40 %	400.0 CCM	408.82 CCM
50 %	500.0 CCM	510.43 CCM
60 %	600.0 CCM	611.44 CCM
70 %	700.0 CCM	713.59 CCM
80 %	800.0 CCM	816.61 CCM
90 %	900.0 CCM	918.19 CCM
100%	1000.0 CCM	1021.3 CCM

Calibration data was last saved on Friday 03 January 97 at 17:55:00

Verified by: Harb Sentiany Date: 1 - 3 - 97

APPENDIX D

TEST METHODS



D-1 EPA METHOD 320





Appendix A of part 63 is amended by adding, in numerical order, Methods 320 and 321 to read as follows:

Appendix A to Part 63-Test Methods

\*\*\*\*\*

## **TEST METHOD 320**

### **MEASUREMENT OF VAPOR PHASE ORGANIC AND INORGANIC EMISSIONS BY EXTRACTIVE FOURIER TRANSFORM INFRARED (FTIR) SPECTROSCOPY**

#### 1.0 Introduction.

Persons unfamiliar with basic elements of FTIR spectroscopy should not attempt to use this method. This method describes sampling and analytical procedures for extractive emission measurements using Fourier transform infrared (FTIR) spectroscopy. Detailed analytical procedures for interpreting infrared spectra are described in the "Protocol for the Use of Extractive Fourier Transform Infrared (FTIR) Spectrometry in Analyses of Gaseous Emissions from Stationary Sources," hereafter referred to as the "Protocol." Definitions not given in this method are given in appendix A of the Protocol. References to specific sections in the Protocol are made throughout this Method. For additional information refer to references 1 and 2, and other EPA reports, which describe the use of FTIR spectrometry in specific field measurement applications and validation tests. The sampling procedure described here is

extractive. Flue gas is extracted through a heated gas transport and handling system. For some sources, sample conditioning systems may be applicable. Some examples are given in this method. Note: sample conditioning systems may be used providing the method validation requirements in Sections 9.2 and 13.0 of this method are met.

#### 1.1 Scope and Applicability.

1.1.1 Analytes. Analytes include hazardous air pollutants (HAPs) for which EPA reference spectra have been developed. Other compounds can also be measured with this method if reference spectra are prepared according to section 4.6 of the protocol.

1.1.2 Applicability. This method applies to the analysis of vapor phase organic or inorganic compounds which absorb energy in the mid-infrared spectral region, about 400 to 4000  $\text{cm}^{-1}$  (25 to 2.5  $\mu\text{m}$ ). This method is used to determine compound-specific concentrations in a multi-component vapor phase sample, which is contained in a closed-path gas cell. Spectra of samples are collected using double beam infrared absorption spectroscopy. A computer program is used to analyze spectra and report compound concentrations.

1.2 Method Range and Sensitivity. Analytical range and sensitivity depend on the frequency-dependent analyte absorptivity, instrument configuration, data collection parameters, and gas stream composition. Instrument factors

include: (a) spectral resolution, (b) interferometer signal averaging time, (c) detector sensitivity and response, and (d) absorption path length.

1.2.1 For any optical configuration the analytical range is between the absorbance values of about .01 (infrared transmittance relative to the background = 0.98) and 1.0 ( $T = 0.1$ ). (For absorbance > 1.0 the relation between absorbance and concentration may not be linear.)

1.2.2 The concentrations associated with this absorbance range depend primarily on the cell path length and the sample temperature. An analyte absorbance greater than 1.0, can be lowered by decreasing the optical path length.

Analyte absorbance increases with a longer path length.

Analyte detection also depends on the presence of other species exhibiting absorbance in the same analytical region. Additionally, the estimated lower absorbance (A) limit ( $A = 0.01$ ) depends on the root mean square deviation (RMSD) noise in the analytical region.

1.2.3 The concentration range of this method is determined by the choice of optical configuration.

1.2.3.1 The absorbance for a given concentration can be decreased by decreasing the path length or by diluting the sample. There is no practical upper limit to the measurement range.

1.2.3.2 The analyte absorbance for a given concentration

may be increased by increasing the cell path length or (to some extent) using a higher resolution. Both modifications also cause a corresponding increased absorbance for all compounds in the sample, and a decrease in the signal throughput. For this reason the practical lower detection range (quantitation limit) usually depends on sample characteristics such as moisture content of the gas, the presence of other interferants, and losses in the sampling system.

1.3 Sensitivity. The limit of sensitivity for an optical configuration and integration time is determined using appendix D of the Protocol: Minimum Analyte Uncertainty, (MAU). The MAU depends on the RMSD noise in an analytical region, and on the absorptivity of the analyte in the same region.

1.4 Data Quality. Data quality shall be determined by executing Protocol pre-test procedures in appendices B to H of the protocol and post-test procedures in appendices I and J of the protocol.

1.4.1 Measurement objectives shall be established by the choice of detection limit ( $DL_i$ ) and analytical uncertainty ( $AU_i$ ) for each analyte.

1.4.2 An instrumental configuration shall be selected. An estimate of gas composition shall be made based on previous test data, data from a similar source or information

gathered in a pre-test site survey. Spectral interferants shall be identified using the selected  $DL_i$  and  $AU_i$  and band areas from reference spectra and interferant spectra. The baseline noise of the system shall be measured in each analytical region to determine the MAU of the instrument configuration for each analyte and interferant ( $MIU_i$ ).

1.4.3 Data quality for the application shall be determined, in part, by measuring the RMS (root mean square) noise level in each analytical spectral region (appendix C of the Protocol). The RMS noise is defined as the RMSD of the absorbance values in an analytical region from the mean absorbance value in the region.

1.4.4 The MAU is the minimum analyte concentration for which the  $AU_i$  can be maintained; if the measured analyte concentration is less than  $MAU_i$ , then data quality are unacceptable.

## 2.0 Summary of Method.

2.1 Principle. References 4 through 7 provide background material on infrared spectroscopy and quantitative analysis. A summary is given in this section.

2.1.1 Infrared absorption spectroscopy is performed by directing an infrared beam through a sample to a detector. The frequency-dependent infrared absorbance of the sample is measured by comparing this detector signal (single beam spectrum) to a signal obtained without a sample in the beam

path (background).

2.1.2 Most molecules absorb infrared radiation and the absorbance occurs in a characteristic and reproducible pattern. The infrared spectrum measures fundamental molecular properties and a compound can be identified from its infrared spectrum alone.

2.1.3 Within constraints, there is a linear relationship between infrared absorption and compound concentration. If this frequency dependent relationship (absorptivity) is known (measured), it can be used to determine compound concentration in a sample mixture.

2.1.4 Absorptivity is measured by preparing, in the laboratory, standard samples of compounds at known concentrations and measuring the FTIR "reference spectra" of these standard samples. These "reference spectra" are then used in sample analysis: (1) compounds are detected by matching sample absorbance bands with bands in reference spectra, and (2) concentrations are measured by comparing sample band intensities with reference band intensities.

2.1.5 This method is self-validating provided that the results meet the performance requirement of the QA spike in sections 8.6.2 and 9.0 of this method, and results from a previous method validation study support the use of this method in the application.

2.2 Sampling and Analysis. In extractive sampling a probe

assembly and pump are used to extract gas from the exhaust of the affected source and transport the sample to the FTIR gas cell. Typically, the sampling apparatus is similar to that used for single-component continuous emission monitor (CEM) measurements.

2.2.1 The digitized infrared spectrum of the sample in the FTIR gas cell is measured and stored on a computer.

Absorbance band intensities in the spectrum are related to sample concentrations by what is commonly referred to as Beer's Law.

$$A_i = a_i b c_i \quad (1)$$

where:

$A_i$  = absorbance at a given frequency of the  $i$ th sample component.

$a_i$  = absorption coefficient (absorptivity) of the  $i$ th sample component.

$b$  = path length of the cell.

$c_i$  = concentration of the  $i$ th sample component.

2.2.2 Analyte spiking is used for quality assurance (QA). In this procedure (section 8.6.2 of this method) an analyte is spiked into the gas stream at the back end of the sample probe. Analyte concentrations in the spiked samples are compared to analyte concentrations in unspiked samples.

Since the concentration of the spike is known, this procedure can be used to determine if the sampling system is removing the spiked analyte(s) from the sample stream.

2.3 Reference Spectra Availability. Reference spectra of over 100 HAPs are available in the EPA FTIR spectral library on the EMTIC (Emission Measurement Technical Information Center) computer bulletin board service and at internet address <http://info.arnold.af.mil/epa/welcome.htm>.

Reference spectra for HAPs, or other analytes, may also be prepared according to section 4.6 of the Protocol.

2.4 Operator Requirements. The FTIR analyst shall be trained in setting up the instrumentation, verifying the instrument is functioning properly, and performing routine maintenance. The analyst must evaluate the initial sample spectra to determine if the sample matrix is consistent with pre-test assumptions and if the instrument configuration is suitable. The analyst must be able to modify the instrument configuration, if necessary.

2.4.1 The spectral analysis shall be supervised by someone familiar with EPA FTIR Protocol procedures.

2.4.2 A technician trained in instrumental test methods is qualified to install and operate the sampling system. This includes installing the probe and heated line assembly, operating the analyte spike system, and performing moisture and flow measurements.



### 3.0 Definitions.

See appendix A of the Protocol for definitions relating to infrared spectroscopy. Additional definitions are given in sections 3.1 through 3.29.

3.1 Analyte. A compound that this method is used to measure. The term "target analyte" is also used. This method is multi-component and a number of analytes can be targeted for a test.

3.2 Reference Spectrum. Infrared spectrum of an analyte prepared under controlled, documented, and reproducible laboratory conditions according to procedures in section 4.6 of the Protocol. A library of reference spectra is used to measure analytes in gas samples.

3.3 Standard Spectrum. A spectrum that has been prepared from a reference spectrum through a (documented) mathematical operation. A common example is de-resolving of reference spectra to lower-resolution standard spectra (Protocol, appendix K to the addendum of this method). Standard spectra, prepared by approved, and documented, procedures can be used as reference spectra for analysis.

3.4 Concentration. In this method concentration is expressed as a molar concentration, in ppm-meters, or in (ppm-meters)/K, where K is the absolute temperature (Kelvin). The latter units allow the direct comparison of concentrations from systems using different optical

configurations or sampling temperatures.

3.5 Interferant. A compound in the sample matrix whose infrared spectrum overlaps with part of an analyte spectrum. The most accurate analyte measurements are achieved when reference spectra of interferants are used in the quantitative analysis with the analyte reference spectra. The presence of an interferant can increase the analytical uncertainty in the measured analyte concentration.

3.6 Gas Cell. A gas containment cell that can be evacuated. It is equipped with the optical components to pass the infrared beam through the sample to the detector. Important cell features include: path length (or range if variable), temperature range, materials of construction, and total gas volume.

3.7 Sampling System. Equipment used to extract the sample from the test location and transport the sample gas to the FTIR analyzer. This includes sample conditioning systems.

3.8 Sample Analysis. The process of interpreting the infrared spectra to obtain sample analyte concentrations. This process is usually automated using a software routine employing a classical least squares (cls), partial least squares (pls), or K- or P- matrix method.

3.9 One hundred percent line. A double beam transmittance spectrum obtained by combining two background single beam spectra. Ideally, this line is equal to 100 percent

..

transmittance (or zero absorbance) at every frequency in the spectrum. Practically, a zero absorbance line is used to measure the baseline noise in the spectrum.

3.10 Background Deviation. A deviation from 100 percent transmittance in any region of the 100 percent line. Deviations greater than  $\pm 5$  percent in an analytical region are unacceptable (absorbance of 0.021 to -0.022). Such deviations indicate a change in the instrument throughput relative to the background single beam.

3.11 Batch Sampling. A procedure where spectra of discrete, static samples are collected. The gas cell is filled with sample and the cell is isolated. The spectrum is collected. Finally, the cell is evacuated to prepare for the next sample.

3.12 Continuous Sampling. A procedure where spectra are collected while sample gas is flowing through the cell at a measured rate.

3.13 Sampling resolution. The spectral resolution used to collect sample spectra.

3.14 Truncation. Limiting the number of interferogram data points by deleting points farthest from the center burst (zero path difference, ZPD).

3.15 Zero filling. The addition of points to the interferogram. The position of each added point is interpolated from neighboring real data points. Zero

filling adds no information to the interferogram, but affects line shapes in the absorbance spectrum (and possibly analytical results).

3.16 Reference CTS. Calibration Transfer Standard spectra that were collected with reference spectra.

3.17 CTS Standard. CTS spectrum produced by applying a de-resolution procedure to a reference CTS.

3.18 Test CTS. CTS spectra collected at the sampling resolution using the same optical configuration as for sample spectra. Test spectra help verify the resolution, temperature and path length of the FTIR system.

3.19 RMSD. Root Mean Square Difference, defined in EPA FTIR Protocol, appendix A.

3.20 Sensitivity. The noise-limited compound-dependent detection limit for the FTIR system configuration. This is estimated by the MAU. It depends on the RMSD in an analytical region of a zero absorbance line.

3.21 Quantitation Limit. The lower limit of detection for the FTIR system configuration in the sample spectra. This is estimated by mathematically subtracting scaled reference spectra of analytes and interferences from sample spectra, then measuring the RMSD in an analytical region of the subtracted spectrum. Since the noise in subtracted sample spectra may be much greater than in a zero absorbance spectrum, the quantitation limit is generally much higher

than the sensitivity. Removing spectral interferences from the sample or improving the spectral subtraction can lower the quantitation limit toward (but not below) the sensitivity.

3.22 Independent Sample. A unique volume of sample gas; there is no mixing of gas between two consecutive independent samples. In continuous sampling two independent samples are separated by at least 5 cell volumes. The interval between independent measurements depends on the cell volume and the sample flow rate (through the cell).

3.23 Measurement. A single spectrum of flue gas contained in the FTIR cell.

3.24 Run. A run consists of a series of measurements. At a minimum a run includes 8 independent measurements spaced over 1 hour.

3.25 Validation. Validation of FTIR measurements is described in sections 13.0 through 13.4 of this method. Validation is used to verify the test procedures for measuring specific analytes at a source. Validation provides proof that the method works under certain test conditions.

3.26 Validation Run. A validation run consists of at least 24 measurements of independent samples. Half of the samples are spiked and half are not spiked. The length of the run is determined by the interval between independent samples.

3.27 Screening. Screening is used when there is little or no available information about a source. The purpose of screening is to determine what analytes are emitted and to obtain information about important sample characteristics such as moisture, temperature, and interferences. Screening results are semi-quantitative (estimated concentrations) or qualitative (identification only). Various optical and sampling configurations may be used. Sample conditioning systems may be evaluated for their effectiveness in removing interferences. It is unnecessary to perform a complete run under any set of sampling conditions. Spiking is not necessary, but spiking can be a useful screening tool for evaluating the sampling system, especially if a reactive or soluble analyte is used for the spike.

3.28 Emissions Test. An FTIR emissions test is performed according specific sampling and analytical procedures. These procedures, for the target analytes and the source, are based on previous screening and validation results. Emission results are quantitative. A QA spike (sections 8.6.2 and 9.2 of this method) is performed under each set of sampling conditions using a representative analyte. Flow, gas temperature and diluent data are recorded concurrently with the FTIR measurements to provide mass emission rates for detected compounds.

3.29 Surrogate. A surrogate is a compound that is used in

a QA spike procedure (section 8.6.2 of this method) to represent other compounds. The chemical and physical properties of a surrogate shall be similar to the compounds it is chosen to represent. Under given sampling conditions, usually a single sampling factor is of primary concern for measuring the target analytes: for example, the surrogate spike results can be representative for analytes that are more reactive, more soluble, have a lower absorptivity, or have a lower vapor pressure than the surrogate itself.

#### 4.0 Interferences.

Interferences are divided into two classifications: analytical and sampling.

4.1 Analytical Interferences. An analytical interference is a spectral feature that complicates (in extreme cases may prevent) the analysis of an analyte. Analytical interferences are classified as background or spectral interference.

4.1.1 Background Interference. This results from a change in throughput relative to the single beam background. It is corrected by collecting a new background and proceeding with the test. In severe instances the cause must be identified and corrected. Potential causes include: (1) deposits on reflective surfaces or transmitting windows, (2) changes in detector sensitivity, (3) a change in the infrared source output, or (4) failure in the instrument electronics. In

routine sampling throughput may degrade over several hours. Periodically a new background must be collected, but no other corrective action will be required.

4.1.2 Spectral Interference. This results from the presence of interfering compound(s) (interferant) in the sample. Interferant spectral features overlap analyte spectral features. Any compound with an infrared spectrum, including analytes, can potentially be an interferant. The Protocol measures absorbance band overlap in each analytical region to determine if potential interferants shall be classified as known interferants (FTIR Protocol, section 4.9 and appendix B). Water vapor and CO<sub>2</sub> are common spectral interferants. Both of these compounds have strong infrared spectra and are present in many sample matrices at high concentrations relative to analytes. The extent of interference depends on the (1) interferant concentration, (2) analyte concentration, and (3) the degree of band overlap. Choosing an alternate analytical region can minimize or avoid the spectral interference. For example, CO<sub>2</sub> interferes with the analysis of the 670 cm<sup>-1</sup> benzene band. However, benzene can also be measured near 3000 cm<sup>-1</sup> (with less sensitivity).

4.2 Sampling System Interferences. These prevent analytes from reaching the instrument. The analyte spike procedure is designed to measure sampling system interference, if any.

..



4.2.1 Temperature. A temperature that is too low causes condensation of analytes or water vapor. The materials of the sampling system and the FTIR gas cell usually set the upper limit of temperature.

4.2.2 Reactive Species. Anything that reacts with analytes. Some analytes, like formaldehyde, polymerize at lower temperatures.

4.2.3 Materials. Poor choice of material for probe, or sampling line may remove some analytes. For example, HF reacts with glass components.

4.2.4 Moisture. In addition to being a spectral interferant, condensed moisture removes soluble compounds.

#### 5.0 Safety.

The hazards of performing this method are those associated with any stack sampling method and the same precautions shall be followed. Many HAPs are suspected carcinogens or present other serious health risks. Exposure to these compounds should be avoided in all circumstances. For instructions on the safe handling of any particular compound, refer to its material safety data sheet. When using analyte standards, always ensure that gases are properly vented and that the gas handling system is leak free. (Always perform a leak check with the system under maximum vacuum and, again, with the system at greater than ambient pressure.) Refer to section 8.2 of this method for

leak check procedures. This method does not address all of the potential safety risks associated with its use. Anyone performing this method must follow safety and health practices consistent with applicable legal requirements and with prudent practice for each application.

#### 6.0 Equipment and Supplies.

Note: Mention of trade names or specific products does not constitute endorsement by the Environmental Protection Agency.

The equipment and supplies are based on the schematic of a sampling system shown in Figure 1. Either the batch or continuous sampling procedures may be used with this sampling system. Alternative sampling configurations may also be used, provided that the data quality objectives are met as determined in the post-analysis evaluation. Other equipment or supplies may be necessary, depending on the design of the sampling system or the specific target analytes.

6.1 Sampling Probe. Glass, stainless steel, or other appropriate material of sufficient length and physical integrity to sustain heating, prevent adsorption of analytes, and to transport analytes to the infrared gas cell. Special materials or configurations may be required in some applications. For instance, high stack sample temperatures may require special steel or cooling the probe.

For very high moisture sources it may be desirable to use a dilution probe.

6.2 Particulate Filters. A glass wool plug (optional) inserted at the probe tip (for large particulate removal) and a filter (required) rated for 99 percent removal efficiency at 1-micron (e.g., Balston™) connected at the outlet of the heated probe.

6.3 Sampling Line/Heating System. Heated (sufficient to prevent condensation) stainless steel, polytetrafluoroethane, or other material inert to the analytes.

6.4 Gas Distribution Manifold. A heated manifold allowing the operator to control flows of gas standards and samples directly to the FTIR system or through sample conditioning systems. Usually includes heated flow meter, heated valve for selecting and sending sample to the analyzer, and a bypass vent. This is typically constructed of stainless steel tubing and fittings, and high-temperature valves.

6.5 Stainless Steel Tubing. Type 316, appropriate diameter (e.g., 3/8 in.) and length for heated connections. Higher grade stainless may be desirable in some applications.

6.6 Calibration/Analyte Spike Assembly. A three way valve assembly (or equivalent) to introduce analyte or surrogate spikes into the sampling system at the outlet of the probe upstream of the out-of-stack particulate filter and the FTIR

analytical system.

6.7 Mass Flow Meter (MFM). These are used for measuring analyte spike flow. The MFM shall be calibrated in the range of 0 to 5 L/min and be accurate to  $\pm 2$  percent (or better) of the flow meter span.

6.8 Gas Regulators. Appropriate for individual gas standards.

6.9 Polytetrafluoroethane Tubing. Diameter (e.g., 3/8 in.) and length suitable to connect cylinder regulators to gas standard manifold.

6.10 Sample Pump. A leak-free pump (e.g., KNF<sup>™</sup>), with by-pass valve, capable of producing a sample flow rate of at least 10 L/min through 100 ft of sample line. If the pump is positioned upstream of the distribution manifold and FTIR system, use a heated pump that is constructed from materials non-reactive to the analytes. If the pump is located downstream of the FTIR system, the gas cell sample pressure will be lower than ambient pressure and it must be recorded at regular intervals.

6.11 Gas Sample Manifold. Secondary manifold to control sample flow at the inlet to the FTIR manifold. This is optional, but includes a by-pass vent and heated rotameter.

6.12 Rotameter. A 0 to 20 L/min rotameter. This meter need not be calibrated.

6.13 FTIR Analytical System. Spectrometer and detector,

capable of measuring the analytes to the chosen detection limit. The system shall include a personal computer with compatible software allowing automated collection of spectra.

6.14 FTIR Cell Pump. Required for the batch sampling technique, capable of evacuating the FTIR cell volume within 2 minutes. The pumping speed shall allow the operator to obtain 8 sample spectra in 1 hour.

6.15 Absolute Pressure Gauge. Capable of measuring pressure from 0 to 1000 mmHg to within  $\pm 2.5$  mmHg (e.g., Baratron<sup>®</sup>).

6.16 Temperature Gauge. Capable of measuring the cell temperature to within  $\pm 2^{\circ}\text{C}$ .

6.17 Sample Conditioning. One option is a condenser system, which is used for moisture removal. This can be helpful in the measurement of some analytes. Other sample conditioning procedures may be devised for the removal of moisture or other interfering species.

6.17.1 The analyte spike procedure of section 9.2 of this method, the QA spike procedure of section 8.6.2 of this method, and the validation procedure of section 13 of this method demonstrate whether the sample conditioning affects analyte concentrations. Alternatively, measurements can be made with two parallel FTIR systems; one measuring conditioned sample, the other measuring unconditioned

sample.

6.17.2 Another option is sample dilution. The dilution factor measurement must be documented and accounted for in the reported concentrations. An alternative to dilution is to lower the sensitivity of the FTIR system by decreasing the cell path length, or to use a short-path cell in conjunction with a long path cell to measure more than one concentration range.

7.0 Reagents and Standards.

7.1 Analyte(s) and Tracer Gas. Obtain a certified gas cylinder mixture containing all of the analyte(s) at concentrations within  $\pm 2$  percent of the emission source levels (expressed in ppm-meter/K). If practical, the analyte standard cylinder shall also contain the tracer gas at a concentration which gives a measurable absorbance at a dilution factor of at least 10:1. Two ppm SF<sub>6</sub> is sufficient for a path length of 22 meters at 250 °F.

7.2 Calibration Transfer Standard(s). Select the calibration transfer standards (CTS) according to section 4.5 of the FTIR Protocol. Obtain a National Institute of Standards and Technology (NIST) traceable gravimetric standard of the CTS ( $\pm 2$  percent).

7.3 Reference Spectra. Obtain reference spectra for each analyte, interferant, surrogate, CTS, and tracer. If EPA reference spectra are not available, use reference spectra

prepared according to procedures in section 4.6 of the EPA FTIR Protocol.

## 8.0 Sampling and Analysis Procedure.

Three types of testing can be performed: (1) screening, (2) emissions test, and (3) validation. Each is defined in section 3 of this method. Determine the purpose(s) of the FTIR test. Test requirements include: (a)  $AU_i$ ,  $DL_i$ , overall fractional uncertainty,  $OFU_i$ , maximum expected concentration ( $C_{MAX_i}$ ), and  $t_{AN}$  for each, (b) potential interferants, (c) sampling system factors, e.g., minimum absolute cell pressure, ( $P_{min}$ ), FTIR cell volume ( $V_{SS}$ ), estimated sample absorption pathlength,  $L_s'$ , estimated sample pressure,  $P_s'$ ,  $T_s'$ , signal integration time ( $t_{SS}$ ), minimum instrumental linewidth, MIL, fractional error, and (d) analytical regions, e.g.,  $m = 1$  to  $M$ , lower wavenumber position,  $FL_m$ , center wavenumber position,  $FC_m$ , and upper wavenumber position,  $FU_m$ , plus interferants, upper wavenumber position of the CTS absorption band,  $FFU_m$ , lower wavenumber position of the CTS absorption band,  $FFL_m$ , wavenumber range FNU to FNL. If necessary, sample and acquire an initial spectrum. From analysis of this preliminary spectrum determine a suitable operational path length. Set up the sampling train as shown in Figure 1 or use an appropriate alternative configuration. Sections 8.1 through 8.11 of this method provide guidance on pre-test calculations in the EPA

protocol, sampling and analytical procedures, and post-test protocol calculations.

8.1 Pretest Preparations and Evaluations. Using the procedure in section 4.0 of the FTIR Protocol, determine the optimum sampling system configuration for measuring the target analytes. Use available information to make reasonable assumptions about moisture content and other interferences.

8.1.1 Analytes. Select the required detection limit ( $DL_i$ ) and the maximum permissible analytical uncertainty ( $AU_i$ ) for each analyte (labeled from 1 to  $i$ ). Estimate, if possible, the maximum expected concentration for each analyte,  $C_{MAX_i}$ . The expected measurement range is fixed by  $DL_i$  and  $C_{MAX_i}$  for each analyte ( $i$ ).

8.1.2 Potential Interferants. List the potential interferants. This usually includes water vapor and  $CO_2$ , but may also include some analytes and other compounds.

8.1.3. Optical Configuration. Choose an optical configuration that can measure all of the analytes within the absorbance range of .01 to 1.0 (this may require more than one path length). Use Protocol sections 4.3 to 4.8 for guidance in choosing a configuration and measuring CTS.

8.1.4. Fractional Reproducibility Uncertainty ( $FRU_i$ ). The FRU is determined for each analyte by comparing CTS spectra taken before and after the reference spectra were measured.



The EPA para-xylene reference spectra were collected on 10/31/91 and 11/01/91 with corresponding CTS spectra "cts1031a," and "cts1101b." The CTS spectra are used to estimate the reproducibility (FRU) in the system that was used to collect the references. The FRU must be  $< AU$ . Appendix E of the protocol is used to calculate the FRU from CTS spectra. Figure 2 plots results for  $0.25 \text{ cm}^{-1}$  CTS spectra in EPA reference library:  $S_3$  (cts1101b - cts1031a), and  $S_4$  [(cts1101b + cts1031a)/2]. The RMSD (SRMS) is calculated in the subtracted baseline,  $S_3$ , in the corresponding CTS region from 850 to  $1065 \text{ cm}^{-1}$ . The area (BAV) is calculated in the same region of the averaged CTS spectrum,  $S_4$ .

8.1.5 Known Interferants. Use appendix B of the EPA FTIR Protocol.

8.1.6 Calculate the Minimum Analyte Uncertainty, MAU (section 1.3 of this method discusses MAU and protocol appendix D gives the MAU procedure). The MAU for each analyte,  $i$ , and each analytical region,  $m$ , depends on the RMS noise.

8.1.7 Analytical Program. See FTIR Protocol, section 4.10. Prepare computer program based on the chosen analytical technique. Use as input reference spectra of all target analytes and expected interferants. Reference spectra of additional compounds shall also be included in the program

if their presence (even if transient) in the samples is considered possible. The program output shall be in ppm (or ppb) and shall be corrected for differences between the reference path length,  $L_R$ , temperature,  $T_R$ , and pressure,  $P_R$ , and the conditions used for collecting the sample spectra. If sampling is performed at ambient pressure, then any pressure correction is usually small relative to corrections for path length and temperature, and may be neglected.

## 8.2 Leak-check.

8.2.1 Sampling System. A typical FTIR extractive sampling train is shown in Figure 1. Leak check from the probe tip to pump outlet as follows: Connect a 0- to 250-mL/min rate meter (rotameter or bubble meter) to the outlet of the pump. Close off the inlet to the probe, and record the leak rate. The leak rate shall be  $\leq 200$  mL/min.

8.2.2 Analytical System Leak check. Leak check the FTIR cell under vacuum and under pressure (greater than ambient). Leak check connecting tubing and inlet manifold under pressure.

8.2.2.1 For the evacuated sample technique, close the valve to the FTIR cell, and evacuate the absorption cell to the minimum absolute pressure  $P_{min}$ . Close the valve to the pump, and determine the change in pressure  $\Delta P_v$  after 2 minutes.

8.2.2.2 For both the evacuated sample and purging techniques, pressurize the system to about 100 mmHg above

..

atmospheric pressure. Isolate the pump and determine the change in pressure  $\Delta P_p$  after 2 minutes.

8.2.2.3 Measure the barometric pressure,  $P_b$  in mmHg.

8.2.2.4 Determine the percent leak volume  $\%V_L$  for the signal integration time  $t_{SS}$  and for  $\Delta P_{max}$ , i.e., the larger of  $\Delta P_v$  or  $\Delta P_p$ , as follows:

$$\%V_L = 50 t_{SS} \frac{\Delta P_{max}}{P_{SS}} \quad (2)$$

where 50 = 100% divided by the leak-check time of 2 minutes.

8.2.2.5 Leak volumes in excess of 4 percent of the FTIR system volume  $V_{SS}$  are unacceptable.

8.3 Detector Linearity. Once an optical configuration is chosen, use one of the procedures of sections 8.3.1 through 8.3.3 to verify that the detector response is linear. If the detector response is not linear, decrease the aperture, or attenuate the infrared beam. After a change in the instrument configuration perform a linearity check until it is demonstrated that the detector response is linear.

8.3.1 Vary the power incident on the detector by modifying the aperture setting. Measure the background and CTS at three instrument aperture settings: (1) at the aperture setting to be used in the testing, (2) at one half this aperture and (3) at twice the proposed testing aperture.

Compare the three CTS spectra. CTS band areas shall agree to within the uncertainty of the cylinder standard and the RMSD noise in the system. If test aperture is the maximum aperture, collect CTS spectrum at maximum aperture, then close the aperture to reduce the IR throughput by half. Collect a second background and CTS at the smaller aperture setting and compare the spectra again.

8.3.2 Use neutral density filters to attenuate the infrared beam. Set up the FTIR system as it will be used in the test measurements. Collect a CTS spectrum. Use a neutral density filter to attenuate the infrared beam (either immediately after the source or the interferometer) to approximately 1/2 its original intensity. Collect a second CTS spectrum. Use another filter to attenuate the infrared beam to approximately 1/4 its original intensity. Collect a third background and CTS spectrum. Compare the CTS spectra. CTS band areas shall agree to within the uncertainty of the cylinder standard and the RMSD noise in the system.

8.3.3 Observe the single beam instrument response in a frequency region where the detector response is known to be zero. Verify that the detector response is "flat" and equal to zero in these regions.

8.4 Data Storage Requirements. All field test spectra shall be stored on a computer disk and a second backup copy must stored on a separate disk. The stored information

includes sample interferograms, processed absorbance spectra, background interferograms, CTS sample interferograms and CTS absorbance spectra. Additionally, documentation of all sample conditions, instrument settings, and test records must be recorded on hard copy or on computer medium. Table 1 gives a sample presentation of documentation.

8.5 Background Spectrum. Evacuate the gas cell to  $\leq 5$  mmHg, and fill with dry nitrogen gas to ambient pressure (or purge the cell with 10 volumes of dry nitrogen). Verify that no significant amounts of absorbing species (for example water vapor and  $\text{CO}_2$ ) are present. Collect a background spectrum, using a signal averaging period equal to or greater than the averaging period for the sample spectra. Assign a unique file name to the background spectrum. Store two copies of the background interferogram and processed single-beam spectrum on separate computer disks (one copy is the back-up).

8.5.1 Interference Spectra. If possible, collect spectra of known and suspected major interferences using the same optical system that will be used in the field measurements. This can be done on-site or earlier. A number of gases, e.g.  $\text{CO}_2$ ,  $\text{SO}_2$ ,  $\text{CO}$ ,  $\text{NH}_3$ , are readily available from cylinder gas suppliers.

8.5.2 Water vapor spectra can be prepared by the following

procedure. Fill a sample tube with distilled water. Evacuate above the sample and remove dissolved gasses by alternately freezing and thawing the water while evacuating. Allow water vapor into the FTIR cell, then dilute to atmospheric pressure with nitrogen or dry air. If quantitative water spectra are required, follow the reference spectrum procedure for neat samples (protocol, section 4.6). Often, interference spectra need not be quantitative, but for best results the absorbance must be comparable to the interference absorbance in the sample spectra.

## 8.6 Pre-Test Calibrations

8.6.1 Calibration Transfer Standard. Evacuate the gas cell to  $\leq 5$  mmHg absolute pressure, and fill the FTIR cell to atmospheric pressure with the CTS gas. Alternatively, purge the cell with 10 cell volumes of CTS gas. (If purge is used, verify that the CTS concentration in the cell is stable by collecting two spectra 2 minutes apart as the CTS gas continues to flow. If the absorbance in the second spectrum is no greater than in the first, within the uncertainty of the gas standard, then this can be used as the CTS spectrum.) Record the spectrum.

8.6.2 QA Spike. This procedure assumes that the method has been validated for at least some of the target analytes at the source. For emissions testing perform a QA spike. Use

a certified standard, if possible, of an analyte, which has been validated at the source. One analyte standard can serve as a QA surrogate for other analytes which are less reactive or less soluble than the standard. Perform the spike procedure of section 9.2 of this method. Record spectra of at least three independent (section 3.22 of this method) spiked samples. Calculate the spiked component of the analyte concentration. If the average spiked concentration is within 0.7 to 1.3 times the expected concentration, then proceed with the testing. If applicable, apply the correction factor from the Method 301 of this appendix validation test (not the result from the QA spike).

8.7 Sampling. If analyte concentrations vary rapidly with time, continuous sampling is preferable using the smallest cell volume, fastest sampling rate and fastest spectra collection rate possible. Continuous sampling requires the least operator intervention even without an automated sampling system. For continuous monitoring at one location over long periods, Continuous sampling is preferred. Batch sampling and continuous static sampling are used for screening and performing test runs of finite duration. Either technique is preferred for sampling several locations in a matter of days. Batch sampling gives reasonably good time resolution and ensures that each spectrum measures a

discreet (and unique) sample volume. Continuous static (and continuous) sampling provide a very stable background over long periods. Like batch sampling, continuous static sampling also ensures that each spectrum measures a unique sample volume. It is essential that the leak check procedure under vacuum (section 8.2 of this method) is passed if the batch sampling procedure is used. It is essential that the leak check procedure under positive pressure is passed if the continuous static or continuous sampling procedures are used. The sampling techniques are described in sections 8.7.1 through 8.7.2 of this method.

8.7.1 Batch Sampling. Evacuate the absorbance cell to  $\leq 5$  mmHg absolute pressure. Fill the cell with exhaust gas to ambient pressure, isolate the cell, and record the spectrum. Before taking the next sample, evacuate the cell until no spectral evidence of sample absorptio remains. Repeat this procedure to collect eight spectra of separate samples in 1 hour.

8.7.2 Continuous Static Sampling. Purge the FTIR cell with 10 cell volumes of sample gas. Isolate the cell, collect the spectrum of the static sample and record the pressure. Before measuring the next sample, purge the cell with 10 more cell volumes of sample gas.

8.8 Sampling QA and Reporting.

8.8.1 Sample integration times shall be sufficient to



achieve the required signal-to-noise ratio. Obtain an absorbance spectrum by filling the cell with N<sub>2</sub>. Measure the RMSD in each analytical region in this absorbance spectrum. Verify that the number of scans used is sufficient to achieve the target MAU.

8.8.2 Assign a unique file name to each spectrum.

8.8.3 Store two copies of sample interferograms and processed spectra on separate computer disks.

8.8.4 For each sample spectrum, document the sampling conditions, the sampling time (while the cell was being filled), the time the spectrum was recorded, the instrumental conditions (path length, temperature, pressure, resolution, signal integration time), and the spectral file name. Keep a hard copy of these data sheets.

8.9 Signal Transmittance. While sampling, monitor the signal transmittance. If signal transmittance (relative to the background) changes by 5 percent or more (absorbance = -.02 to .02) in any analytical spectral region, obtain a new background spectrum.

8.10 Post-test CTS. After the sampling run, record another CTS spectrum.

8.11 Post-test QA.

8.11.1 Inspect the sample spectra immediately after the run to verify that the gas matrix composition was close to the expected (assumed) gas matrix.

8.11.2 Verify that the sampling and instrumental parameters were appropriate for the conditions encountered. For example, if the moisture is much greater than anticipated, it may be necessary to use a shorter path length or dilute the sample.

8.11.3 Compare the pre- and post-test CTS spectra. The peak absorbance in pre- and post-test CTS must be  $\pm 5$  percent of the mean value. See appendix E of the FTIR Protocol.

#### 9.0 Quality Control.

Use analyte spiking (sections 8.6.2, 9.2 and 13.0 of this method) to verify that the sampling system can transport the analytes from the probe to the FTIR system.

9.1 Spike Materials. Use a certified standard (accurate to  $\pm 2$  percent) of the target analyte, if one can be obtained. If a certified standard cannot be obtained, follow the procedures in section 4.6.2.2 of the FTIR Protocol.

9.2 Spiking Procedure. QA spiking (section 8.6.2 of this method) is a calibration procedure used before testing. QA spiking involves following the spike procedure of sections 9.2.1 through 9.2.3 of this method to obtain at least three spiked samples. The analyte concentrations in the spiked samples shall be compared to the expected spike concentration to verify that the sampling/analytical system is working properly. Usually, when QA spiking is used, the

method has already been validated at a similar source for the analyte in question. The QA spike demonstrates that the validated sampling/analytical conditions are being duplicated. If the QA spike fails then the sampling/analytical system shall be repaired before testing proceeds. The method validation procedure (section 13.0 of this method) involves a more extensive use of the analyte spike procedure of sections 9.2.1 through 9.2.3 of this method. Spectra of at least 12 independent spiked and 12 independent unspiked samples are recorded. The concentration results are analyzed statistically to determine if there is a systematic bias in the method for measuring a particular analyte. If there is a systematic bias, within the limits allowed by Method 301 of this appendix, then a correction factor shall be applied to the analytical results. If the systematic bias is greater than the allowed limits, this method is not valid and cannot be used.

9.2.1 Introduce the spike/tracer gas at a constant flow rate of  $\leq 10$  percent of the total sample flow, when possible. (Note: Use the rotameter at the end of the sampling train to estimate the required spike/tracer gas flow rate.) Use a flow device, e.g., mass flow meter ( $\pm 2$  percent), to monitor the spike flow rate. Record the spike flow rate every 10 minutes.

9.2.2 Determine the response time (RT) of the system by continuously collecting spectra of the spiked effluent until the spectrum of the spiked component is constant for 5 minutes. The RT is the interval from the first measurement until the spike becomes constant. Wait for twice the duration of the RT, then collect spectra of two independent spiked gas samples. Duplicate analyses of the spiked concentration shall be within 5 percent of the mean of the two measurements.

9.2.3 Calculate the dilution ratio using the tracer gas as follows:

$$DF = \frac{SF_{6(spik)}}{SF_{6(dir)}} \quad (3)$$

where:

$$CS = DF * Spike_{dir} + Unspike(1-DF) \quad (4)$$

DF = Dilution factor of the spike gas; this value shall be  $\geq 10$ .

$SF_{6(dir)}$  =  $SF_6$  (or tracer gas) concentration measured directly in undiluted spike gas.

$SF_{6(spik)}$  = Diluted  $SF_6$  (or tracer gas) concentration measured in a spiked sample.

..

Spike<sub>dir</sub> = Concentration of the analyte in the spike standard measured by filling the FTIR cell directly.

CS = Expected concentration of the spiked samples.

Unspike = Native concentration of analytes in unspiked samples

10.0 Calibration and Standardization.

10.1 Signal-to-Noise Ratio (S/N). The RMSD in the noise must be less than one tenth of the minimum analyte peak absorbance in each analytical region. For example if the minimum peak absorbance is 0.01 at the required DL, then RMSD measured over the entire analytical region must be  $\leq 0.001$ .

10.2 Absorbance Path length. Verify the absorbance path length by comparing reference CTS spectra to test CTS spectra. See appendix E of the FTIR Protocol.

10.3 Instrument Resolution. Measure the line width of appropriate test CTS band(s) to verify instrument resolution. Alternatively, compare CTS spectra to a reference CTS spectrum, if available, measured at the nominal resolution.

10.4 Apodization Function. In transforming the sample interferograms to absorbance spectra use the same

apodization function that was used in transforming the reference spectra.

10.5 FTIR Cell Volume. Evacuate the cell to  $\leq 5$  mmHg. Measure the initial absolute temperature ( $T_i$ ) and absolute pressure ( $P_i$ ). Connect a wet test meter (or a calibrated dry gas meter), and slowly draw room air into the cell. Measure the meter volume ( $V_m$ ), meter absolute temperature ( $T_m$ ), and meter absolute pressure ( $P_m$ ); and the cell final absolute temperature ( $T_f$ ) and absolute pressure ( $P_f$ ). Calculate the FTIR cell volume  $V_{SS}$ , including that of the connecting tubing, as follows:

$$V_{SS} = \frac{V_m \frac{P_m}{T_m}}{\left[ \frac{P_f}{T_f} - \frac{P_i}{T_i} \right]} \quad (5)$$

#### 11.0 Data Analysis and Calculations.

Analyte concentrations shall be measured using reference spectra from the EPA FTIR spectral library. When EPA library spectra are not available, the procedures in section 4.6 of the Protocol shall be followed to prepare reference spectra of all the target analytes.

11.1 Spectral De-resolution. Reference spectra can be converted to lower resolution standard spectra (section 3.3

of this method) by truncating the original reference sample and background interferograms. Appendix K of the FTIR Protocol gives specific deresolution procedures. Deresolved spectra shall be transformed using the same apodization function and level of zero filling as the sample spectra. Additionally, pre-test FTIR protocol calculations (e.g., FRU, MAU, FCU) shall be performed using the de-resolved standard spectra.

11.2 Data Analysis. Various analytical programs are available for relating sample absorbance to a concentration standard. Calculated concentrations shall be verified by analyzing residual baselines after mathematically subtracting scaled reference spectra from the sample spectra. A full description of the data analysis and calculations is contained in the FTIR Protocol (sections 4.0, 5.0, 6.0 and appendices). Correct the calculated concentrations in the sample spectra for differences in absorption path length and temperature between the reference and sample spectra using equation 6,

$$C_{corr} = \left( \frac{L_r}{L_s} \right) \left( \frac{T_s}{T_r} \right) \left( \frac{P_r}{P_s} \right) C_{calc} \quad (6)$$

where:

$C_{corr}$  = Concentration, corrected for path length.

$C_{calc}$  = Concentration, initial calculation (output of the analytical program designed for the compound).

$L_r$  = Reference spectra path length.

$L_s$  = Sample spectra path length.

$T_s$  = Absolute temperature of the sample gas, K.

$T_r$  = Absolute gas temperature of reference spectra, K.

$P_s$  = Sample cell pressure.

$P_r$  = Reference spectrum sample pressure.

## 12.0 Method Performance.

12.1 Spectral Quality. Refer to the FTIR Protocol appendices for analytical requirements, evaluation of data quality, and analysis of uncertainty.

12.2 Sampling QA/QC. The analyte spike procedure of section 9 of this method, the QA spike of section 8.6.2 of this method, and the validation procedure of section 13 of this method are used to evaluate the performance of the sampling system and to quantify sampling system effects, if any, on the measured concentrations. This method is self-validating provided that the results meet the performance requirement of the QA spike in sections 9.0 and 8.6.2 of this method and results from a previous method validation study support the use of this method in the application. Several factors can contribute to uncertainty in the measurement of spiked samples. Factors which can be controlled to provide better accuracy in the spiking procedure are listed in sections 12.2.1 through 12.2.4 of this method.



12.2.1 Flow meter. An accurate mass flow meter is accurate to  $\pm 1$  percent of its span. If a flow of 1 L/min is monitored with such a MFM, which is calibrated in the range of 0-5 L/min, the flow measurement has an uncertainty of 5 percent. This may be improved by re-calibrating the meter at the specific flow rate to be used.

12.2.2 Calibration gas. Usually the calibration standard is certified to within  $\pm 2$  percent. With reactive analytes, such as HCl, the certified accuracy in a commercially available standard may be no better than  $\pm 5$  percent.

12.2.3 Temperature. Temperature measurements of the cell shall be quite accurate. If practical, it is preferable to measure sample temperature directly, by inserting a thermocouple into the cell chamber instead of monitoring the cell outer wall temperature.

12.2.4 Pressure. Accuracy depends on the accuracy of the barometer, but fluctuations in pressure throughout a day may be as much as 2.5 percent due to weather variations.

### 13.0 Method Validation Procedure.

This validation procedure, which is based on EPA Method 301 (40 CFR part 63, appendix A), may be used to validate this method for the analytes in a gas matrix. Validation at one source may also apply to another type of source, if it can be shown that the exhaust gas characteristics are similar at both sources.

13.1 Section 5.3 of Method 301 (40 CFR part 63, appendix A), the Analyte Spike procedure, is used with these modifications. The statistical analysis of the results follows section 6.3 of EPA Method 301. Section 3 of this method defines terms that are not defined in Method 301.

13.1.1 The analyte spike is performed dynamically. This means the spike flow is continuous and constant as spiked samples are measured.

13.1.2 The spike gas is introduced at the back of the sample probe.

13.1.3 Spiked effluent is carried through all sampling components downstream of the probe.

13.1.4 A single FTIR system (or more) may be used to collect and analyze spectra (not quadruplicate integrated sampling trains).

13.1.5 All of the validation measurements are performed sequentially in a single "run" (section 3.26 of this method).

13.1.6 The measurements analyzed statistically are each independent (section 3.22 of this method).

13.1.7 A validation data set can consist of more than 12 spiked and 12 unspiked measurements.

13.2 Batch Sampling. The procedure in sections 13.2.1 through 13.2.2 may be used for stable processes. If process emissions are highly variable, the procedure in section

13.2.3 shall be used.

13.2.1 With a single FTIR instrument and sampling system, begin by collecting spectra of two unspiked samples.

Introduce the spike flow into the sampling system and allow 10 cell volumes to purge the sampling system and FTIR cell. Collect spectra of two spiked samples. Turn off the spike and allow 10 cell volumes of unspiked sample to purge the FTIR cell. Repeat this procedure until the 24 (or more) samples are collected.

13.2.2 In batch sampling, collect spectra of 24 distinct samples. (Each distinct sample consists of filling the cell to ambient pressure after the cell has been evacuated.)

13.2.3 Alternatively, a separate probe assembly, line, and sample pump can be used for spiked sample. Verify and document that sampling conditions are the same in both the spiked and the unspiked sampling systems. This can be done by wrapping both sample lines in the same heated bundle. Keep the same flow rate in both sample lines. Measure samples in sequence in pairs. After two spiked samples are measured, evacuate the FTIR cell, and turn the manifold valve so that spiked sample flows to the FTIR cell. Allow the connecting line from the manifold to the FTIR cell to purge thoroughly (the time depends on the line length and flow rate). Collect a pair of spiked samples. Repeat the procedure until at least 24 measurements are completed.

13.3 Simultaneous Measurements With Two FTIR Systems. If unspiked effluent concentrations of the target analyte(s) vary significantly with time, it may be desirable to perform synchronized measurements of spiked and unspiked sample. Use two FTIR systems, each with its own cell and sampling system to perform simultaneous spiked and unspiked measurements. The optical configurations shall be similar, if possible. The sampling configurations shall be the same. One sampling system and FTIR analyzer shall be used to measure spiked effluent. The other sampling system and FTIR analyzer shall be used to measure unspiked flue gas. Both systems shall use the same sampling procedure (i.e., batch or continuous).

13.3.1 If batch sampling is used, synchronize the cell evacuation, cell filling, and collection of spectra. Fill both cells at the same rate (in cell volumes per unit time).

13.3.2 If continuous sampling is used, adjust the sample flow through each gas cell so that the same number of cell volumes pass through each cell in a given time (i.e.  $TC_1 = TC_2$ ).

13.4 Statistical Treatment. The statistical procedure of EPA Method 301 of this appendix, section 6.3 is used to evaluate the bias and precision. For FTIR testing a validation "run" is defined as spectra of 24 independent samples, 12 of which are spiked with the analyte(s) and 12

of which are not spiked.

13.4.1 Bias. Determine the bias (defined by EPA Method 301 of this appendix, section 6.3.2) using equation 7:

$$B = S_m - CS \quad (7)$$

where:

B = Bias at spike level.

$S_m$  = Mean concentration of the analyte spiked samples.

CS = Expected concentration of the spiked samples.

13.4.2 Correction Factor. Use section 6.3.2.2 of Method 301 of this appendix to evaluate the statistical significance of the bias. If it is determined that the bias is significant, then use section 6.3.3 of Method 301 to calculate a correction factor (CF). Analytical results of the test method are multiplied by the correction factor, if  $0.7 \leq CF \leq 1.3$ . If it is determined that the bias is significant and  $CF > \pm 30$  percent, then the test method is considered to "not valid."

13.4.3 If measurements do not pass validation, evaluate the sampling system, instrument configuration, and analytical system to determine if improper set-up or a malfunction was the cause. If so, repair the system and repeat the validation.

#### 14.0 Pollution Prevention.

The extracted sample gas is vented outside the enclosure containing the FTIR system and gas manifold after the analysis. In typical method applications the vented sample volume is a small fraction of the source volumetric flow and its composition is identical to that emitted from the source. When analyte spiking is used, spiked pollutants are vented with the extracted sample gas. Approximately  $1.6 \times 10^{-4}$  to  $3.2 \times 10^{-4}$  lbs of a single HAP may be vented to the atmosphere in a typical validation run of 3 hours. (This assumes a molar mass of 50 to 100 g, spike rate of 1.0 L/min, and a standard concentration of 100 ppm). Minimize emissions by keeping the spike flow off when not in use.

#### 15.0 Waste Management.

Small volumes of laboratory gas standards can be vented through a laboratory hood. Neat samples must be packed and disposed according to applicable regulations. Surplus materials may be returned to supplier for disposal.

#### 16.0 References.

1. "Field Validation Test Using Fourier Transform Infrared (FTIR) Spectrometry To Measure Formaldehyde, Phenol and Methanol at a Wool Fiberglass Production Facility." Draft. U.S. Environmental Protection Agency Report, EPA Contract No. 68D20163, Work Assignment I-32, September 1994.
2. "FTIR Method Validation at a Coal-Fired Boiler".

Prepared for U.S. Environmental Protection Agency, Research Triangle Park, NC. Publication No.: EPA-454/R95-004, NTIS No.: PB95-193199. July, 1993.

3. "Method 301 - Field Validation of Pollutant Measurement Methods from Various Waste Media," **40 CFR part 63, appendix A.**
4. "Molecular Vibrations; The Theory of Infrared and Raman Vibrational Spectra," E. Bright Wilson, J. C. Decius, and P. C. Cross, Dover Publications, Inc., 1980. For a less intensive treatment of molecular rotational-vibrational spectra see, for example, "Physical Chemistry," G. M. Barrow, chapters 12, 13, and 14, McGraw Hill, Inc., 1979.
5. "Fourier Transform Infrared Spectrometry," Peter R. Griffiths and James de Haseth, **Chemical Analysis, 83**, 16-25, (1986), P. J. Elving, J. D. Winefordner and I. M. Kolthoff (ed.), John Wiley and Sons.
6. "Computer-Assisted Quantitative Infrared Spectroscopy," Gregory L. McClure (ed.), **ASTM Special Publication 934** (ASTM), 1987.
7. "Multivariate Least-Squares Methods Applied to the Quantitative Spectral Analysis of Multicomponent Mixtures," **Applied Spectroscopy, 39** (10), 73-84, 1985.

Table 1. EXAMPLE PRESENTATION OF SAMPLING DOCUMENTATION.

Sample Time	Spectrum File Name	Background File Name	Sample conditioning	Process condition

Sample Time	Spectrum File	Interferogram	Resolution	Scans	Apodization	Gain	CTS Spectrum



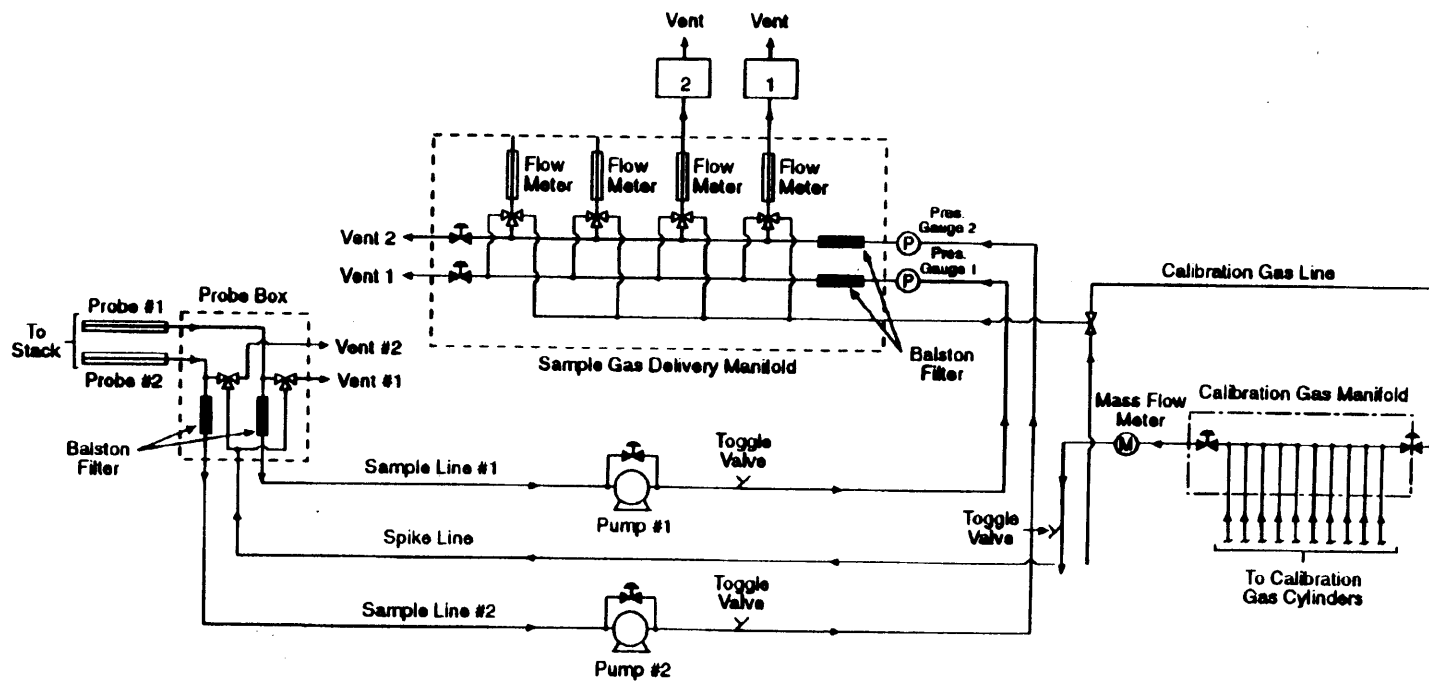

**Figure 1.** Extractive FTIR sampling system.

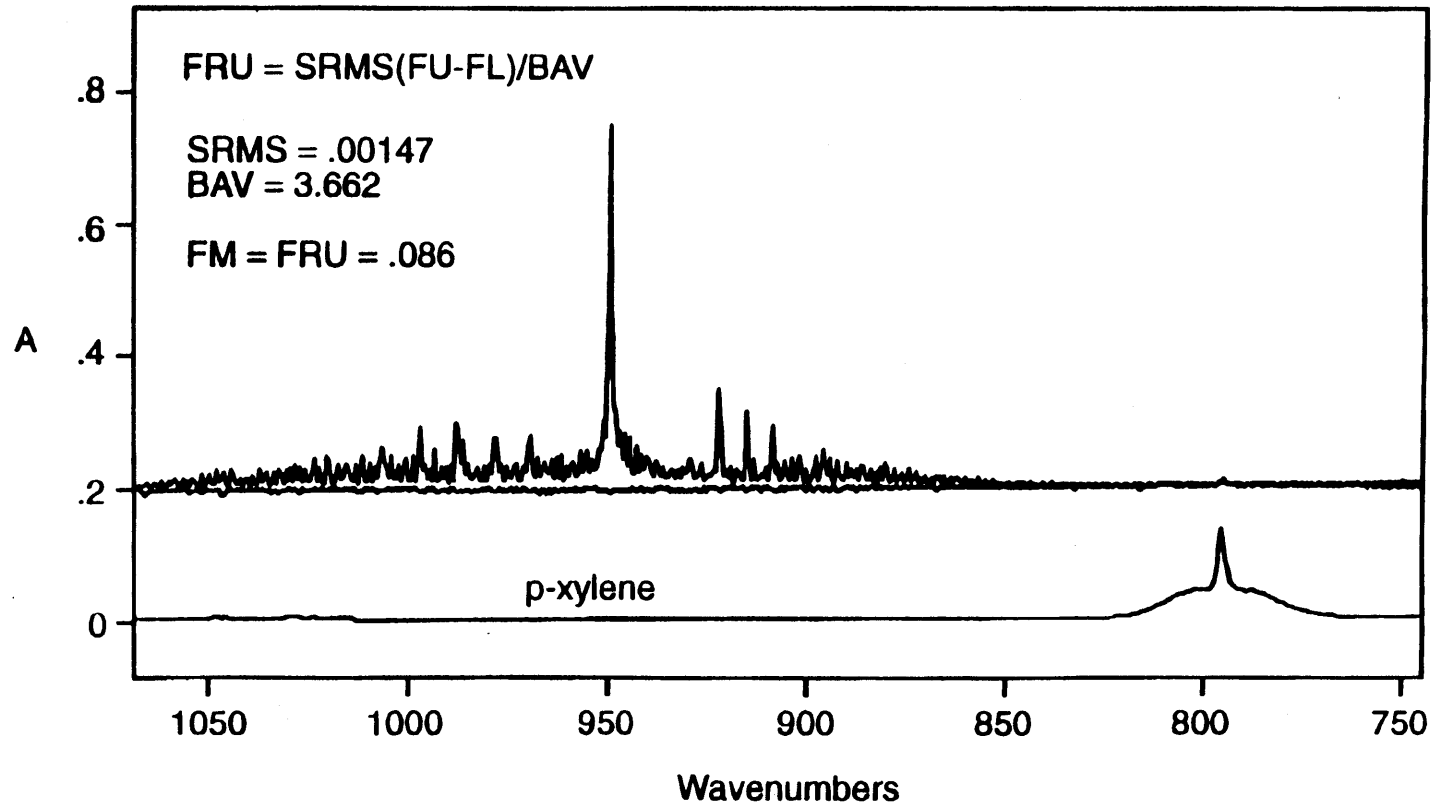

**Figure 2.** Fractional Reproducibility. Top: average of cts1031a and cts1101b. Bottom: Reference spectrum of p-xylene.

D-2 EPA FTIR PROTOCOL



**PROTOCOL FOR THE USE OF EXTRACTIVE FOURIER TRANSFORM  
INFRARED (FTIR) SPECTROMETRY FOR THE ANALYSES OF GASEOUS  
EMISSIONS FROM STATIONARY SOURCES**

**INTRODUCTION**

The purpose of this document is to set general guidelines for the use of modern FTIR spectroscopic methods for the analysis of gas samples extracted from the effluent of stationary emission sources. This document outlines techniques for developing and evaluating such methods and sets basic requirements for reporting and quality assurance procedures.

**1.0 NOMENCLATURE**

1.1 Appendix A lists definitions of the symbols and terms used in this Protocol, many of which have been taken directly from American Society for Testing and Materials (ASTM) publication E 131-90a, entitled "Terminology Relating to Molecular Spectroscopy."

1.2 Except in the case of background spectra or where otherwise noted, the term "spectrum" refers to a double-beam spectrum in units of absorbance vs. wavenumber ( $\text{cm}^{-1}$ ).

1.3 The term "Study" in this document refers to a publication that has been subjected to EPA- or peer-review.

**2.0 APPLICABILITY AND ANALYTICAL PRINCIPLE**

2.1 Applicability. This Protocol applies to the determination of compound-specific concentrations in single- and multiple-component gas phase samples using double-beam absorption spectroscopy in the mid-infrared band. It does not specifically address other FTIR applications, such as single-beam spectroscopy, analysis of open-path (non-enclosed) samples, and continuous measurement techniques. If multiple spectrometers, absorption cells, or instrumental linewidths are used in such analyses, each distinct operational configuration of the system must be evaluated separately according to this Protocol.

**2.2 Analytical Principle.**

2.2.1 In the mid-infrared band, most molecules exhibit characteristic gas phase absorption spectra that may be recorded by FTIR systems. Such systems consist of a source of mid-infrared radiation, an interferometer, an enclosed sample cell of known absorption pathlength, an infrared detector, optical elements for the transfer of infrared radiation between components, and gas flow control and measurement components. Adjunct and integral computer systems are used for controlling the instrument, processing the signal, and for performing both Fourier transforms and quantitative analyses of spectral data.

2.2.2 The absorption spectra of pure gases and of mixtures of gases are described by a linear absorbance theory referred to as Beer's Law. Using this law, modern FTIR systems use computerized analytical programs to quantify compounds by comparing the absorption spectra of known (reference) gas samples to the absorption spectrum of the sample gas. Some standard mathematical techniques used for comparisons are classical least squares, inverse least squares, cross-correlation, factor analysis, and partial least squares. Reference A describes several of these techniques, as well as additional techniques, such as differentiation methods, linear baseline corrections, and non-linear absorbance corrections.

### 3.0 GENERAL PRINCIPLES OF PROTOCOL REQUIREMENTS

The characteristics that distinguish FTIR systems from gas analyzers used in instrumental gas analysis methods (e.g., EPA Methods 6C and 7E) are: (1) Computers are necessary to obtain and analyze data; (2) chemical concentrations can be quantified using previously recorded infrared reference spectra; and (3) analytical assumptions and results, including possible effects of interfering compounds, can be evaluated after the quantitative analysis. The following general principles and requirements of this Protocol are based on these characteristics.

3.1 Verifiability and Reproducibility of Results. Store all data and document data analysis techniques sufficient to allow an independent agent to reproduce the analytical results from the raw interferometric data.

3.2 Transfer of Reference Spectra. To determine whether reference spectra recorded under one set of conditions (e.g., optical bench, instrumental linewidth, absorption pathlength, detector performance, pressure, and temperature) can be used to analyze sample spectra taken under a different set of conditions, quantitatively compare "calibration transfer standards" (CTS) and reference spectra as described in this Protocol. (Note: The CTS may, but need not, include analytes of interest). To effect this, record the absorption spectra of the CTS (a) immediately before and immediately after recording reference spectra and (b) immediately after recording sample spectra.

3.3 Evaluation of FTIR Analyses. The applicability, accuracy, and precision of FTIR measurements are influenced by a number of interrelated factors, which may be divided into two classes:

3.3.1 Sample-Independent Factors. Examples are system configuration and performance (e.g., detector sensitivity and infrared source output), quality and applicability of reference absorption spectra, and type of mathematical analyses of the spectra. These factors define the fundamental limitations of FTIR measurements for a given system configuration. These limitations may be estimated from evaluations of the system before samples are available. For example, the detection limit for the absorbing compound under a given set of conditions may be

estimated from the system noise level and the strength of a particular absorption band. Similarly, the accuracy of measurements may be estimated from the analysis of the reference spectra.

3.3.2 Sample-Dependent Factors. Examples are spectral interferants (e.g., water vapor and  $\text{CO}_2$ ) or the overlap of spectral features of different compounds and contamination deposits on reflective surfaces or transmitting windows. To maximize the effectiveness of the mathematical techniques used in spectral analysis, identification of interferants (a standard initial step) and analysis of samples (includes effects of other analytical errors) are necessary. Thus, the Protocol requires post-analysis calculation of measurement concentration uncertainties for the detection of these potential sources of measurement error.

#### 4.0 PRE-TEST PREPARATIONS AND EVALUATIONS

Before testing, demonstrate the suitability of FTIR spectrometry for the desired application according to the procedures of this section.

4.1 Identify Test Requirements. Identify and record the test requirements described below in 4.1.1 through 4.1.5. These values set the desired or required goals of the proposed analysis; the description of methods for determining whether these goals are actually met during the analysis comprises the majority of this Protocol.

4.1.1 Analytes (specific chemical species) of interest. Label the analytes from  $i = 1$  to  $I$ .

4.1.2 Analytical uncertainty limit ( $\text{AU}_i$ ). The  $\text{AU}_i$  is the maximum permissible fractional uncertainty of analysis for the  $i^{\text{th}}$  analyte concentration, expressed as a fraction of the analyte concentration in the sample.

4.1.3 Required detection limit for each analyte ( $\text{DL}_i$ , ppm). The detection limit is the lowest concentration of an analyte for which its overall fractional uncertainty ( $\text{OFU}_i$ ) is required to be less than its analytical uncertainty limit ( $\text{AU}_i$ ).

4.1.4 Maximum expected concentration of each analyte ( $\text{CMAX}_i$ , ppm).

4.2 Identify Potential Interferants. Considering the chemistry of the process or results of previous Studies, identify potential interferants, i.e., the major effluent constituents and any relatively minor effluent constituents that possess either strong absorption characteristics or strong structural similarities to any analyte of interest. Label them 1 through  $N_j$ , where the subscript "j" pertains to potential interferants. Estimate the concentrations of these compounds in the effluent ( $\text{CPOT}_j$ , ppm).

4.3 Select and Evaluate the Sampling System. Considering the source, e.g., temperature and pressure profiles, moisture content, analyte characteristics, and particulate concentration), select the equipment for extracting gas samples. Recommended are a particulate filter, heating system to maintain sample temperature above the dew point for all sample constituents at all points within the sampling system (including the filter), and sample conditioning system (e.g., coolers, water-permeable membranes that remove water or other compounds from the sample, and dilution devices) to remove spectral interferants or to protect the sampling and analytical components. Determine the minimum absolute sample system pressure ( $P_{min}$ , mmHg) and the infrared absorption cell volume ( $V_{ss}$ , liter). Select the techniques and/or equipment for the measurement of sample pressures and temperatures.

4.4 Select Spectroscopic System. Select a spectroscopic configuration for the application. Approximate the absorption pathlength ( $L_s$ , meter), sample pressure ( $P_s$ , kPa), absolute sample temperature  $T_s$ , and signal integration period ( $t_{ss}$ , seconds) for the analysis. Specify the nominal minimum instrumental linewidth (MIL) of the system. Verify that the fractional error at the approximate values  $P_s$  and  $T_s$  is less than one half the smallest value  $AU_i$  (see Section 4.1.2).

4.5 Select Calibration Transfer Standards (CTS's). Select CTS's that meet the criteria listed in Sections 4.5.1, 4.5.2, and 4.5.3.

**Note:** It may be necessary to choose preliminary analytical regions (see Section 4.7), identify the minimum analyte linewidths, or estimate the system noise level (see Section 4.12) before selecting the CTS. More than one compound may be needed to meet the criteria; if so, obtain separate cylinders for each compound.

4.5.1 The central wavenumber position of each analytical region lies within 25 percent of the wavenumber position of at least one CTS absorption band.

4.5.2 The absorption bands in 4.5.1 exhibit peak absorbances greater than ten times the value  $RMS_{EST}$  (see Section 4.12) but less than 1.5 absorbance units.

4.5.3 At least one absorption CTS band within the operating range of the FTIR instrument has an instrument-independent linewidth no greater than the narrowest analyte absorption band; perform and document measurements or cite Studies to determine analyte and CTS compound linewidths.

4.5.4 For each analytical region, specify the upper and lower wavenumber positions ( $FFU_m$  and  $FFL_m$ , respectively) that bracket the CTS absorption band or bands for the associated analytical region. Specify the wavenumber range,  $FNU$  to  $FNL$ , containing the absorption band that meets the criterion of Section 4.5.3.



4.5.5 Associate, whenever possible, a single set of CTS gas cylinders with a set of reference spectra. Replacement CTS gas cylinders shall contain the same compounds at concentrations within 5 percent of that of the original CTS cylinders; the entire absorption spectra (not individual spectral segments) of the replacement gas shall be scaled by a factor between 0.95 and 1.05 to match the original CTS spectra.

#### 4.6 Prepare Reference Spectra.

Note: Reference spectra are available in a permanent soft copy from the EPA spectral library on the EMTIC (Emission Measurement Technical Information Center) computer bulletin board; they may be used if applicable.

4.6.1 Select the reference absorption pathlength ( $L_r$ ) of the cell.

4.6.2 Obtain or prepare a set of chemical standards for each analyte, potential and known spectral interferants, and CTS. Select the concentrations of the chemical standards to correspond to the top of the desired range.

4.6.2.1 Commercially-Prepared Chemical Standards. Chemical standards for many compounds may be obtained from independent sources, such as a specialty gas manufacturer, chemical company, or commercial laboratory. These standards (accurate to within  $\pm 2$  percent) shall be prepared according to EPA Protocol 1 (see Reference D) or shall be traceable to NIST standards. Obtain from the supplier an estimate of the stability of the analyte concentration; obtain and follow all the supplier's recommendations for recertifying the analyte concentration.

4.6.2.2 Self-Prepared Chemical Standards. Chemical standards may be prepared as follows: Dilute certified commercially prepared chemical gases or pure analytes with ultra-pure carrier (UPC) grade nitrogen according to the barometric and volumetric techniques generally described in Reference A, Section A4.6.

4.6.3 Record a set of the absorption spectra of the CTS ( $R_1$ ), then a set of the reference spectra at two or more concentrations in duplicate over the desired range (the top of the range must be less than 10 times that of the bottom), followed by a second set of CTS spectra ( $R_2$ ). (If self-prepared standards are used, see Section 4.6.5 before disposing of any of the standards.) The maximum accepted standard concentration-pathlength product (ASCPP) for each compound shall be higher than the maximum estimated concentration-pathlength products for both analytes and known interferants in the effluent gas. For each analyte, the minimum ASCPP shall be no greater than ten times the concentration-pathlength product of that analyte at its required detection limit.

4.6.4 Permanently store the background and interferograms in digitized form. Document details of the mathematical process for generating the spectra from these interferograms. Record the

sample pressure ( $P_R$ ), sample temperature ( $T_R$ ), reference absorption pathlength ( $L_R$ ), and interferogram signal integration period ( $t_{SR}$ ). Signal integration periods for the background interferograms shall be  $\geq t_{SR}$ . Values of  $P_R$ ,  $L_R$ , and  $t_{SR}$  shall not deviate by more than  $\pm 1$  percent from the time of recording {R1} to that of recording {R2}.

4.6.5 If self-prepared chemical standards are employed and spectra of only two concentrations are recorded for one or more compounds, verify the accuracy of the dilution technique by analyzing the prepared standards for those compounds with a secondary (non-FTIR) technique as follows:

4.6.5.1 Record the response of the secondary technique to each of the four standards prepared.

4.6.5.2 Perform a linear regression of the response values (dependant variable) versus the accepted standard concentration (ASC) values (independent variable), with the regression constrained to pass through the zero-response, zero ASC point.

4.6.5.3 Calculate the average fractional difference between the actual response values and the regression-predicted values (those calculated from the regression line using the four ASC values as the independent variable).

4.6.5.4 If the average fractional difference value calculated in Section 4.6.5.3 is larger for any compound than the corresponding  $AU_i$ , the dilution technique is not sufficiently accurate and the reference spectra prepared are not valid for the analysis.

4.7 Select Analytical Regions. Using the general considerations in Section 7 of Reference A and the spectral characteristics of the analytes and interferants, select the analytical regions for the application. Label them  $m = 1$  to  $M$ . Specify the lower, center and upper wavenumber positions of each analytical region ( $FL_m$ ,  $FC_m$ , and  $FU_m$ , respectively). Specify the analytes and interferants which exhibit absorption in each region.

4.8 Determine Fractional Reproducibility Uncertainties. Using Appendix E, calculate the fractional reproducibility uncertainty for each analyte ( $FRU_i$ ) from a comparison of {R1} and {R2}. If  $FRU_i > AU_i$  for any analyte, the reference spectra generated in Section 4.6 are not valid for the application.

4.9 Identify Known Interferants. Using Appendix B, determine which potential interferant affects the analyte concentration determinations. If it does, relabel the potential interferant as "known" interferant, and designate these compounds from  $k = 1$  to  $K$ . Appendix B also provides criteria for determining whether the selected analytical regions are suitable.

4.10 Prepare Computerized Analytical Programs.

4.10.1 Choose or devise mathematical techniques (e.g., classical least squares, inverse least squares, cross-correlation, and factor analysis) based on Equation 4 of Reference A that are appropriate for analyzing spectral data by comparison with reference spectra.

4.10.2 Following the general recommendations of Reference A, prepare a computer program or set of programs that analyzes all the analytes and known interferants, based on the selected analytical regions (4.7) and the prepared reference spectra (4.6). Specify the baseline correction technique (e.g., determining the slope and intercept of a linear baseline contribution in each analytical region) for each analytical region, including all relevant wavenumber positions.

4.10.3 Use programs that provide as output [at the reference absorption pathlength ( $L_R$ ), reference gas temperature ( $T_R$ ), and reference gas pressure ( $P_R$ )] the analyte concentrations, the known interferant concentrations, and the baseline slope and intercept values. If the sample absorption pathlength ( $L_S$ ), sample gas temperature ( $T_S$ ) or sample gas pressure ( $P_S$ ) during the actual sample analyses differ from  $L_R$ ,  $T_R$ , and  $P_R$ , use a program or set of programs that applies multiplicative corrections to the derived concentrations to account for these variations, and that provides as output both the corrected and uncorrected values. Include in the report of the analysis (see Section 7.0) the details of any transformations applied to the original reference spectra (e.g., differentiation), in such a fashion that all analytical results may be verified by an independent agent from the reference spectra and data spectra alone.

4.11 Determine the Fractional Calibration Uncertainty. Calculate the fractional calibration uncertainty for each analyte ( $FCU_i$ ) according to Appendix F, and compare these values to the fractional uncertainty limits ( $AU_i$ ; see Section 4.1). If  $FCU_i > AU_i$ , either the reference spectra or analytical programs for that analyte are unsuitable.

4.12 Verify System Configuration Suitability. Using Appendix C, measure or obtain estimates of the noise level ( $RMS_{EST}$ , absorbance) of the FTIR system; alternatively, construct the complete spectrometer system and determine the values  $RMS_{sm}$  using Appendix G. Estimate the minimum measurement uncertainty for each analyte ( $MAU_i$ , ppm) and known interferant ( $MIU_k$ , ppm) using Appendix D. Verify that (a)  $MAU_i < (AU_i)(DL_i)$ ,  $FRU_i < AU_i$ , and  $FCU_i < AU_i$  for each analyte and that (b) the CTS chosen meets the requirements listed in Section 4.5.

## 5.0 SAMPLING AND ANALYSIS PROCEDURE

5.1 Analysis System Assembly and Leak-Test. Assemble the analysis system. Allow sufficient time for all system components to reach the desired temperature. Then determine the leak-rate ( $L_R$ ) and leak volume ( $V_L$ ), where  $V_L = L_R t_{SS}$ . Leak volumes shall be  $\leq 4$  percent of  $V_{SS}$ .

5.2 Verify Instrumental Performance. Measure the noise level of the system in each analytical region using the procedure of Appendix G. If any noise level is higher than that estimated for the system in Section 4.12, repeat the calculations of Appendix D and verify that the requirements of Section 4.12 are met; if they are not, adjust or repair the instrument and repeat this section.

5.3 Determine the Sample Absorption Pathlength. Record a background spectrum. Then, fill the absorption cell with CTS at the pressure  $P_R$  and record a set of CTS spectra (R3). Store the background and unscaled CTS single beam interferograms and spectra. Using Appendix H, calculate the sample absorption pathlength ( $L_S$ ) for each analytical region. The values  $L_S$  shall not differ from the approximated sample pathlength  $L_S'$  (see Section 4.4) by more than 5 percent.

5.4 Record Sample Spectrum. Connect the sample line to the source. Either evacuate the absorption cell to an absolute pressure below 5 mmHg before extracting a sample from the effluent stream into the absorption cell, or pump at least ten cell volumes of sample through the cell before obtaining a sample. Record the sample pressure  $P_S$ . Generate the absorbance spectrum of the sample. Store the background and sample single beam interferograms, and document the process by which the absorbance spectra are generated from these data. (If necessary, apply the spectral transformations developed in Section 5.6.2). The resulting sample spectrum is referred to below as  $S_S$ .

**Note:** Multiple sample spectra may be recorded according to the procedures of Section 5.4 before performing Sections 5.5 and 5.6.

5.5 Quantify Analyte Concentrations. Calculate the unscaled analyte concentrations  $RUA_i$  and unscaled interferant concentrations  $RUI_k$  using the programs developed in Section 4. To correct for pathlength and pressure variations between the reference and sample spectra, calculate the scaling factor  $R_{LPS} = (L_R P_R T_S) / (L_S P_S T_R)$ . Calculate the final analyte and interferant concentrations  $RSA_i = R_{LPS} RUA_i$  and  $RSI_k = R_{LPS} RUI_k$ .

5.6 Determine Fractional Analysis Uncertainty. Fill the absorption cell with CTS at the pressure  $P_S$ . Record a set of CTS spectra (R4). Store the background and CTS single beam interferograms. Using Appendix H, calculate the fractional analysis uncertainty (FAU) for each analytical region. If the FAU indicated for any analytical region is larger than the required accuracy requirements determined in Section 4.1, then comparisons to previously recorded reference spectra are invalid in that analytical region, and the analyst shall perform one or both of the following procedures:

5.6.1 Perform instrumental checks and adjust the instrument to restore its performance to acceptable levels. If adjustments are made, repeat Sections 5.3, 5.4 (except for the recording of a sample spectrum), and 5.5 to demonstrate that acceptable uncertainties are obtained in all analytical regions.

5.6.2 Apply appropriate mathematical transformations (e.g., frequency shifting, zero-filling, apodization, smoothing) to the spectra (or to the interferograms upon which the spectra are based) generated during the performance of the procedures of Section 5.3. Document these transformations and their reproducibility. Do not apply multiplicative scaling of the spectra, or any set of transformations that is mathematically equivalent to multiplicative scaling. Different transformations may be applied to different analytical regions. Frequency shifts shall be smaller than one-half the minimum instrumental linewidth, and must be applied to all spectral data points in an analytical region. The mathematical transformations may be retained for the analysis if they are also applied to the appropriate analytical regions of all sample spectra recorded, and if all original sample spectra are digitally stored. Repeat Sections 5.3, 5.4 (except the recording of a sample spectrum), and 5.5 to demonstrate that these transformations lead to acceptable calculated concentration uncertainties in all analytical regions.

## **6.0 POST-ANALYSIS EVALUATIONS**

Estimate the overall accuracy of the analyses performed in Section 5 as follows:

6.1 Qualitatively Confirm the Assumed Matrix. Examine each analytical region of the sample spectrum for spectral evidence of unexpected or unidentified interferants. If found, identify the interfering compounds (see Reference C for guidance) and add them to the list of known interferants. Repeat the procedures of Section 4 to include the interferants in the uncertainty calculations and analysis procedures. Verify that the MAU and FCU values do not increase beyond acceptable levels for the application requirements. Re-calculate the analyte concentrations (Section 5.5) in the affected analytical regions.

6.2 Quantitatively Evaluate Fractional Model Uncertainty (FMU). Perform the procedures of either Section 6.2.1 or 6.2.2:

6.2.1 Using Appendix I, determine the fractional model error (FMU) for each analyte.

6.2.2 Provide statistically determined uncertainties FMU for each analyte which are equivalent to two standard deviations at the 95% confidence level. Such determinations, if employed, must be based on mathematical examinations of the pertinent sample spectra (not the reference spectra alone). Include in the report of the analysis (see Section 7.0) a complete description of the determination of the concentration uncertainties.

6.3 Estimate Overall Concentration Uncertainty (OCU). Using Appendix J, determine the overall concentration uncertainty (OCU) for each analyte. If the OCU is larger than the required accuracy for any analyte, repeat Sections 4 and 6.

## **7.0 REPORTING REQUIREMENTS**

[Documentation pertaining to virtually all the procedures of Sections 4, 5, and 6 will be required. Software copies of reference spectra and sample spectra will be retained for some minimum time following the actual testing.]

## 8.0 REFERENCES

- A) Standard Practices for General Techniques of Infrared Quantitative Analysis (American Society for Testing and Materials, Designation E 168-88).
- B) The Coblenz Society Specifications for Evaluation of Research Quality Analytical Infrared Reference Spectra (Class II); Anal. Chemistry 47, 945A (1975); **Appl. Spectroscopy** 44, pp. 211-215, 1990.
- C) Standard Practices for General Techniques for Qualitative Infrared Analysis, American Society for Testing and Materials, Designation E 1252-88.
- D) "Traceability Protocol for Establishing True Concentrations of Gases Used for Calibration and Audits of Continuous Emissions Monitors (Protocol Number 1)," June 1978, Quality Assurance Handbook for Air Pollution Measurement Systems, Volume III, Stationary Source Specific Methods, EPA-600/4-77-027b, August 1977.





## APPENDIX A

### DEFINITIONS OF TERMS AND SYMBOLS

#### A.1 Definitions of Terms

**absorption band** - a contiguous wavenumber region of a spectrum (equivalently, a contiguous set of absorbance spectrum data points) in which the absorbance passes through a maximum or a series of maxima.

**absorption pathlength** - in a spectrophotometer, the distance, measured in the direction of propagation of the beam of radiant energy, between the surface of the specimen on which the radiant energy is incident and the surface of the specimen from which it is emergent.

**analytical region** - a contiguous wavenumber region (equivalently, a contiguous set of absorbance spectrum data points) used in the quantitative analysis for one or more analyte.

Note: The quantitative result for a single analyte may be based on data from more than one analytical region.

**apodization** - modification of the ILS function by multiplying the interferogram by a weighing function whose magnitude varies with retardation.

**background spectrum** - the single beam spectrum obtained with all system components without sample present.

**baseline** - any line drawn on an absorption spectrum to establish a reference point that represents a function of the radiant power incident on a sample at a given wavelength.

**Beers's law** - the direct proportionality of the absorbance of a compound in a homogeneous sample to its concentration.

**calibration transfer standard (CTS) gas** - a gas standard of a compound used to achieve and/or demonstrate suitable quantitative agreement between sample spectra and the reference spectra; see Section 4.5.1.

**compound** - a substance possessing a distinct, unique molecular structure.

**concentration (c)** - the quantity of a compound contained in a unit quantity of sample. The unit "ppm" (number, or mole, basis) is recommended.

**concentration-pathlength product** - the mathematical product of concentration of the species and absorption pathlength. For reference spectra, this is a known quantity; for sample spectra, it is the quantity directly determined from Beer's law. The units "centimeters-ppm" or "meters-ppm" are recommended.

**derivative absorption spectrum** - a plot of rate of change of absorbance or of any function of absorbance with respect to wavelength or any function of wavelength.

**double beam spectrum** - a transmission or absorbance spectrum derived by dividing the sample single beam spectrum by the background spectrum.

Note: The term "double-beam" is used elsewhere to denote a spectrum in which the sample and background interferograms are collected simultaneously along physically distinct absorption paths. Here, the term denotes a spectrum in which the sample and background interferograms are collected at different times along the same absorption path.

**fast Fourier transform (FFT)** - a method of speeding up the computation of a discrete FT by factoring the data into sparse matrices containing mostly zeros.

**flyback** - interferometer motion during which no data are recorded.

**Fourier transform (FT)** - the mathematical process for converting an amplitude-time spectrum to an amplitude-frequency spectrum, or vice versa.

**Fourier transform infrared (FTIR) spectrometer** - an analytical system that employs a source of mid-infrared radiation, an interferometer, an enclosed sample cell of known absorption pathlength, an infrared detector, optical elements that transfer infrared radiation between components, and a computer system. The time-domain detector response (interferogram) is processed by a Fourier transform to yield a representation of the detector response vs. infrared frequency.

Note: When FTIR spectrometers are interfaced with other instruments, a slash should be used to denote the interface; e.g., GC/FTIR; HPCL/FTIR, and the use of FTIR should be explicit; i.e., FTIR not IR.

**frequency,  $\nu$**  - the number of cycles per unit time.

**infrared** - the portion of the electromagnetic spectrum containing wavelengths from approximately 0.78 to 800 microns.

**interferogram,  $I(\sigma)$**  - record of the modulated component of the interference signal measured as a function of retardation by the detector.

**interferometer** - device that divides a beam of radiant energy into two or more paths, generate an optical path difference between the beams, and recombines them in order to produce repetitive interference maxima and minima as the optical retardation is varied.

**linewidth** - the full width at half maximum of an absorption band in units of wavenumbers ( $\text{cm}^{-1}$ ).

**mid-infrared** - the region of the electromagnetic spectrum from approximately 400 to 5000  $\text{cm}^{-1}$ .

**pathlength** - see "absorption pathlength."

**reference spectra** - absorption spectra of gases with known chemical compositions, recorded at a known absorption pathlength, which are used in the quantitative analysis of gas samples.

**retardation,  $\sigma$**  - optical path difference between two beams in an interferometer; also known as "optical path difference" or "optical retardation."

**scan** - digital representation of the detector output obtained during one complete motion of the interferometer's moving assembly or assemblies.

**scaling** - application of a multiplicative factor to the absorbance values in a spectrum.

**single beam spectrum** - Fourier-transformed interferogram, representing the detector response vs. wavenumber.

Note: The term "single-beam" is used elsewhere to denote any spectrum in which the sample and background interferograms are recorded on the same physical absorption path; such usage differentiates such spectra from those generated using interferograms recorded along two physically distinct absorption paths (see "double-beam spectrum" above). Here, the term applies (for example) to the two spectra used directly in the calculation of transmission and absorbance spectra of a sample.

**standard reference material** - a reference material, the composition or properties of which are certified by a recognized standardizing agency or group.

Note: The equivalent ISO term is "certified reference material."

**transmittance,  $T$**  - the ratio of radiant power transmitted by the sample to the radiant power incident on the sample. Estimated in FTIR spectroscopy by forming the ratio of the single-beam sample and background spectra.

**wavenumber,  $\nu$**  - the number of waves per unit length.

Note: The usual unit of wavenumber is the reciprocal centimeter,  $\text{cm}^{-1}$ . The wavenumber is the reciprocal of the wavelength,  $\lambda$ , when  $\lambda$  is expressed in centimeters.

**zero-filling** - the addition of zero-valued points to the end of a measured interferogram.

Note: Performing the FT of a zero-filled interferogram results in correctly interpolated points in the computed spectrum.

## A.2 Definitions of Mathematical Symbols

**A, absorbance** - the logarithm to the base 10 of the reciprocal of the transmittance (T).

$$A = \log_{10} \left( \frac{1}{T} \right) = -\log_{10} T \quad (1)$$

**AAI<sub>im</sub>** - band area of the i<sup>th</sup> analyte in the m<sup>th</sup> analytical region, at the concentration (CL<sub>i</sub>) corresponding to the product of its required detection limit (DL<sub>i</sub>) and analytical uncertainty limit (AU<sub>i</sub>).

**AAV<sub>im</sub>** - average absorbance of the i<sup>th</sup> analyte in the m<sup>th</sup> analytical region, at the concentration (CL<sub>i</sub>) corresponding to the product of its required detection limit (DL<sub>i</sub>) and analytical uncertainty limit (AU<sub>i</sub>).

**ASC, accepted standard concentration** - the concentration value assigned to a chemical standard.

**ASCPP, accepted standard concentration-pathlength product** - for a chemical standard, the product of the ASC and the sample absorption pathlength. The units "centimeters-ppm" or "meters-ppm" are recommended.

**AU<sub>i</sub>, analytical uncertainty limit** - the maximum permissible fractional uncertainty of analysis for the i<sup>th</sup> analyte concentration, expressed as a fraction of the analyte concentration determined in the analysis.

**AVT<sub>m</sub>** - average estimated total absorbance in the m<sup>th</sup> analytical region.

**CKWN<sub>k</sub>** - estimated concentration of the k<sup>th</sup> known interferant.

**C<sub>MAX</sub><sub>i</sub>** - estimated maximum concentration of the i<sup>th</sup> analyte.

**CPOT<sub>j</sub>** - estimated concentration of the j<sup>th</sup> potential interferant.

**DL<sub>i</sub>, required detection limit** - for the i<sup>th</sup> analyte, the lowest concentration of the analyte for which its overall fractional uncertainty (OFU<sub>i</sub>) is required to be less than the analytical uncertainty limit (AU<sub>i</sub>).

**FC<sub>m</sub>** - center wavenumber position of the m<sup>th</sup> analytical region.

**FAU<sub>i</sub>, fractional analytical uncertainty** - calculated uncertainty in the measured concentration of the i<sup>th</sup> analyte because of

errors in the mathematical comparison of reference and sample spectra.

- FCU<sub>i</sub>**, **fractional calibration uncertainty** - calculated uncertainty in the measured concentration of the  $i^{\text{th}}$  analyte because of errors in Beer's law modeling of the reference spectra concentrations.
- FFL<sub>m</sub>** - lower wavenumber position of the CTS absorption band associated with the  $m^{\text{th}}$  analytical region.
- FFU<sub>m</sub>** - upper wavenumber position of the CTS absorption band associated with the  $m^{\text{th}}$  analytical region.
- FL<sub>m</sub>** - lower wavenumber position of the  $m^{\text{th}}$  analytical region.
- FMU<sub>i</sub>**, **fractional model uncertainty** - calculated uncertainty in the measured concentration of the  $i^{\text{th}}$  analyte because of errors in the absorption model employed.
- FN<sub>i</sub>** - lower wavenumber position of the CTS spectrum containing an absorption band at least as narrow as the analyte absorption bands.
- FN<sub>o</sub>** - upper wavenumber position of the CTS spectrum containing an absorption band at least as narrow as the analyte absorption bands.
- FRU<sub>i</sub>**, **fractional reproducibility uncertainty** - calculated uncertainty in the measured concentration of the  $i^{\text{th}}$  analyte because of errors in the reproducibility of spectra from the FTIR system.
- FU<sub>m</sub>** - upper wavenumber position of the  $m^{\text{th}}$  analytical region.
- IAI<sub>j,m</sub>** - band area of the  $j^{\text{th}}$  potential interferant in the  $m^{\text{th}}$  analytical region, at its expected concentration (CPOT<sub>j</sub>).
- IAV<sub>i,m</sub>** - average absorbance of the  $i^{\text{th}}$  analyte in the  $m^{\text{th}}$  analytical region, at its expected concentration (CPOT<sub>j</sub>).
- ISC<sub>i</sub> or k**, **indicated standard concentration** - the concentration from the computerized analytical program for a single-compound reference spectrum for the  $i^{\text{th}}$  analyte or  $k^{\text{th}}$  known interferant.
- kPa** - kilo-Pascal (see Pascal).
- L<sub>s</sub>'** - estimated sample absorption pathlength.
- L<sub>r</sub>** - reference absorption pathlength.
- L<sub>s</sub>** - actual sample absorption pathlength.
- MAU<sub>i</sub>** - mean of the MAU<sub>i,m</sub> over the appropriate analytical regions.

**MAU<sub>i,m</sub>**, **minimum analyte uncertainty** - the calculated minimum concentration for which the analytical uncertainty limit (AU<sub>i</sub>) in the measurement of the i<sup>th</sup> analyte, based on spectral data in the m<sup>th</sup> analytical region, can be maintained.

**MIU<sub>j,m</sub>**, - mean of the MIU<sub>j,m</sub> over the appropriate analytical regions.

**MIU<sub>j,m</sub>**, **minimum interferant uncertainty** - the calculated minimum concentration for which the analytical uncertainty limit CPOT<sub>j</sub>/20 in the measurement of the j<sup>th</sup> interferant, based on spectral data in the m<sup>th</sup> analytical region, can be maintained.

**MIL**, **minimum instrumental linewidth** - the minimum linewidth from the FTIR system, in wavenumbers.

**Note:** The MIL of a system may be determined by observing an absorption band known (through higher resolution examinations) to be narrower than indicated by the system. The MIL is fundamentally limited by the retardation of the interferometer, but is also affected by other operational parameters (e.g., the choice of apodization).

**N<sub>i</sub>** - number of analytes.

**N<sub>j</sub>** - number of potential interferants.

**N<sub>k</sub>** - number of known interferants.

**N<sub>scan</sub>** - the number of scans averaged to obtain an interferogram.

**OFU<sub>i</sub>** - the overall fractional uncertainty in an analyte concentration determined in the analysis (OFU<sub>i</sub> = MAX{FRU<sub>i</sub>, FCU<sub>i</sub>, FAU<sub>i</sub>, FMU<sub>i</sub>}).

**Pascal (Pa)** - metric unit of static pressure, equal to one Newton per square meter; one atmosphere is equal to 101,325 Pa; 1/760 atmosphere (one Torr, or one millimeter Hg) is equal to 133.322 Pa.

**P<sub>min</sub>** - minimum pressure of the sampling system during the sampling procedure.

**P<sub>s</sub>'** - estimated sample pressure.

**P<sub>r</sub>** - reference pressure.

**P<sub>s</sub>** - actual sample pressure.

**RMS<sub>m</sub>** - measured noise level of the FTIR system in the m<sup>th</sup> analytical region.

**RMSD**, **root mean square difference** - a measure of accuracy determined by the following equation:

$$\text{RMSD} = \sqrt{\left(\frac{1}{n}\right) \sum_{i=1}^n e_i^2} \quad (2)$$

where:

$n$  = the number of observations for which the accuracy is determined.

$e_i$  = the difference between a measured value of a property and its mean value over the  $n$  observations.

Note: The RMSD value "between a set of  $n$  contiguous absorbance values ( $A_i$ ) and the mean of the values" ( $A_M$ ) is defined as

$$\text{RMSD} = \sqrt{\left(\frac{1}{n}\right) \sum_{i=1}^n (A_i - A_M)^2} \quad (3)$$

$RSA_i$  - the (calculated) final concentration of the  $i^{\text{th}}$  analyte.

$RSI_k$  - the (calculated) final concentration of the  $k^{\text{th}}$  known interferant.

$t_{\text{scan}}$ , **scan time** - time used to acquire a single scan, not including flyback.

$t_s$ , **signal integration period** - the period of time over which an interferogram is averaged by addition and scaling of individual scans. In terms of the number of scans  $N_{\text{scan}}$  and scan time  $t_{\text{scan}}$ ,  $t_s = N_{\text{scan}} t_{\text{scan}}$ .

$t_{\text{ref}}$  - signal integration period used in recording reference spectra.

$t_{\text{sam}}$  - signal integration period used in recording sample spectra.

$T_{\text{ref}}$  - absolute temperature of gases used in recording reference spectra.

$T_{\text{sam}}$  - absolute temperature of sample gas as sample spectra are recorded.

**TP, Throughput** - manufacturer's estimate of the fraction of the total infrared power transmitted by the absorption cell and transfer optics from the interferometer to the detector.

$V_{\text{cell}}$  - volume of the infrared absorption cell, including parts of attached tubing.

$W_{ik}$  - weight used to average over analytical regions  $k$  for quantities related to the analyte  $i$ ; see Appendix D.

Note that some terms are missing, e.g., BAV<sub>1</sub>, OCU, RMSS<sub>2</sub>, SUB<sub>3</sub>,  
SIC<sub>1</sub>, SAC<sub>1</sub>, S<sub>3</sub>



## APPENDIX B

### IDENTIFYING SPECTRAL INTERFERANTS

#### B.1 General

B.1.1 Assume a fixed absorption pathlength equal to the value  $L_s'$ .

B.1.2 Use band area calculations to compare the relative absorption strengths of the analytes and potential interferants. In the  $m^{\text{th}}$  analytical region ( $FL_m$  to  $FU_m$ ), use either rectangular or trapezoidal approximations to determine the band areas described below (see Reference A, Sections A.3.1 through A.3.3); document any baseline corrections applied to the spectra.

B.1.3 Use the average total absorbance of the analytes and potential interferants in each analytical region to determine whether the analytical region is suitable for analyte concentration determinations.

**Note:** The average absorbance in an analytical region is the band area divided by the width of the analytical region in wavenumbers. The average total absorbance in an analytical region is the sum of the average absorbances of all analytes and potential interferants.

#### B.2 Calculations

B.2.1 Prepare spectral representations of each analyte at the concentration  $CL_i = (DL_i)(AU_i)$ , where  $DL_i$  is the required detection limit and  $AU_i$  is the maximum permissible analytical uncertainty. For the  $m^{\text{th}}$  analytical region, calculate the band area ( $AAI_{i,m}$ ) and average absorbance ( $AAV_{i,m}$ ) from these scaled analyte spectra.

B.2.2 Prepare spectral representations of each potential interferant at its expected concentration ( $CPOT_j$ ). For the  $m^{\text{th}}$  analytical region, calculate the band area ( $IAI_{j,m}$ ) and average absorbance ( $IAV_{j,m}$ ) from these scaled potential interferant spectra.

B.2.3 Repeat the calculation for each analytical region, and record the band area results in matrix form as indicated in Figure B.1.

B.2.4 If the band area of any potential interferant in an analytical region is greater than the one-half the band area of any analyte (i.e.,  $IAI_{j,m} > 0.5 AAI_{i,m}$  for any pair  $ij$  and any  $m$ ), classify the potential interferant as known interferant. Label the known interferants  $k = 1$  to  $K$ . Record the results in matrix form as indicated in Figure B.2.

B.2.5 Calculate the average total absorbance ( $AVT_m$ ) for each analytical region and record the values in the last row of the

matrix described in Figure B.2. Any analytical region where  $AVT_m > 2.0$  is unsuitable.

FIGURE B.1 Presentation of Potential Interferant Calculations

		Analytical Regions	
		1	M
		<hr/>	
		Analyte Labels	
1		AAI <sub>11</sub>	AAI <sub>1M</sub>
.		.	.
I		AAI <sub>I1</sub>	AAI <sub>IM</sub>
		<hr/>	
		Potential Interferant Labels	
1		IAI <sub>11</sub>	IAI <sub>1M</sub>
.		.	.
J		IAI <sub>J1</sub>	IAI <sub>JM</sub>

FIGURE B.2 Presentation of Known Interferant Calculations

		Analytical Regions	
		1	M
		<hr/>	
		Analyte Labels	
1		AAI <sub>11</sub>	AAI <sub>1M</sub>
.		.	.
I		AAI <sub>I1</sub>	AAI <sub>IM</sub>
		<hr/>	
		Known Interferant Labels	
1		IAI <sub>11</sub>	IAI <sub>1M</sub>
.		.	.
K		IAI <sub>K1</sub>	IAI <sub>KM</sub>
		<hr/>	
		Total Average Absorbance	
		AVT <sub>1</sub>	AVT <sub>M</sub>

## APPENDIX C

### ESTIMATING NOISE LEVELS

#### C.1 General

C.1.1 The root-mean-square (RMS) noise level is the standard measure of noise in this Protocol. The RMS noise level of a contiguous segment of a spectrum is defined as the RMS difference (RMSD) between the absorbance values which form the segment and the mean value of that segment (see Appendix A).

C.1.2 The RMS noise value in double-beam absorbance spectra is assumed to be inversely proportional to: (a) the square root of the signal integration period of the sample single beam spectra from which it is formed, and (b) to the total infrared power transmitted through the interferometer and absorption cell.

C.1.3 Practically, the assumption of C.1.2 allow the RMS noise level of a complete system to be estimated from the following four quantities:

- (a)  $RMS_{MAN}$  - the noise level of the system (in absorbance units), without the absorption cell and transfer optics, under those conditions necessary to yield the specified minimum instrumental linewidth, e.g., Jacquinot stop size.
- (b)  $t_{MAN}$  - the manufacturer's signal integration time used to determine  $RMS_{MAN}$ .
- (c)  $t_{SS}$  - the signal integration time for the analyses.
- (d) TP - the manufacturer's estimate of the fraction of the total infrared power transmitted by the absorption cell and transfer optics from the interferometer to the detector.

#### C.2 Calculations

C.2.1 Obtain the values of  $RMS_{MAN}$ ,  $t_{MAN}$ , and TP from the manufacturers of the equipment, or determine the noise level by direct measurements with the completely constructed system proposed in Section 4.

C.2.2 Calculate the noise value of the system ( $RMS_{EST}$ ) as follows:

$$RMS_{EST} = RMS_{MAN} TP \sqrt{\frac{t_{SS}}{t_{MAN}}} \quad (4)$$



## APPENDIX D

### ESTIMATING MINIMUM CONCENTRATION MEASUREMENT UNCERTAINTIES (MAU and MIU)

#### D.1 General

Estimate the minimum concentration measurement uncertainties for the  $i^{\text{th}}$  analyte ( $\text{MAU}_i$ ) and  $j^{\text{th}}$  interferant ( $\text{MIU}_j$ ) based on the spectral data in the  $m^{\text{th}}$  analytical region by comparing the analyte band area in the analytical region ( $\text{AAI}_{im}$ ) and estimating or measuring the noise level of the system ( $\text{RMS}_{\text{EST}}$  or  $\text{RMS}_{\text{SM}}$ ).

Note: For a single analytical region, the MAU or MIU value is the concentration of the analyte or interferant for which the band area is equal to the product of the analytical region width (in wavenumbers) and the noise level of the system (in absorbance units). If data from more than one analytical region is used in the determination of an analyte concentration, the MAU or MIU is the mean of the separate MAU or MIU values calculated for each analytical region.

#### D.2 Calculations

D.2.1 For each analytical region, set  $\text{RMS} = \text{RMS}_{\text{SM}}$  if measured (Appendix G), or set  $\text{RMS} = \text{RMS}_{\text{EST}}$  if estimated (Appendix C).

D.2.2 For each analyte associated with the analytical region, calculate

$$\text{MAU}_{im} = (\text{RMS}) (\text{DL}_i) (\text{AU}_i) \frac{(\text{FU}_m - \text{FL}_m)}{\text{AAI}_{im}} \quad (5)$$

D.2.3 If only the  $m^{\text{th}}$  analytical region is used to calculate the concentration of the  $i^{\text{th}}$  analyte, set  $\text{MAU}_i = \text{MAU}_{im}$ .

D.2.4 If a number of analytical regions are used to calculate the concentration of the  $i^{\text{th}}$  analyte, set  $\text{MAU}_i$  equal to the weighted mean of the appropriate  $\text{MAU}_{im}$  values calculated above; the weight for each term in the mean is equal to the fraction of the total wavenumber range used for the calculation represented by each analytical region. Mathematically, if the set of analytical regions employed is  $\{m'\}$ , then the MAU for each analytical region is

$$MAU_i = \sum_{k \in (m')} W_{ik} MAU_{ik} \quad (6)$$

where the weight  $W_{ik}$  is defined for each term in the sum as

$$W_{ik} = (FM_k - FL_k) \left( \sum_{p \in (m')} [FM_p - FL_p] \right)^{-1} \quad (7)$$

D.2.5 Repeat Sections D.2.1 through D.2.4 to calculate the analogous values  $MIU_j$  for the interferants  $j = 1$  to  $J$ . Replace the value  $(AU_i)(DL_i)$  in the above equations with  $CPOT_j/20$ ; replace the value  $AAI_{im}$  in the above equations with  $IAI_{jm}$ .

## APPENDIX E

### DETERMINING FRACTIONAL REPRODUCIBILITY UNCERTAINTIES (FRU)

#### E.1 General

To estimate the reproducibility of the spectroscopic results of the system, compare the CTS spectra recorded before and after preparing the reference spectra. Compare the difference between the spectra to their average band area. Perform the calculation for each analytical region on the portions of the CTS spectra associated with that analytical region.

#### E.2 Calculations

E.2.1 The CTS spectra {R1} consist of N spectra, denoted by  $S_{1i}$ ,  $i=1, N$ . Similarly, the CTS spectra {R2} consist of N spectra, denoted by  $S_{2i}$ ,  $i=1, N$ . Each  $S_{ki}$  is the spectrum of a single compound, where  $i$  denotes the compound and  $k$  denotes the set {Rk} of which  $S_{ki}$  is a member. Form the spectra  $S_3$  according to  $S_{3i} = S_{2i} - S_{1i}$  for each  $i$ . Form the spectra  $S_4$  according to  $S_{4i} = [S_{2i} + S_{1i}] / 2$  for each  $i$ .

E.2.2 Each analytical region  $m$  is associated with a portion of the CTS spectra  $S_{2i}$  and  $S_{1i}$ , for a particular  $i$ , with lower and upper wavenumber limits  $FFL_m$  and  $FFU_m$ , respectively.

E.2.3 For each  $m$  and the associated  $i$ , calculate the band area of  $S_{4i}$  in the wavenumber range  $FFU_m$  to  $FFL_m$ . Follow the guidelines of Section B.1.2 for this band area calculation. Denote the result by  $BAV_m$ .

E.2.4 For each  $m$  and the associated  $i$ , calculate the RMSD of  $S_{3i}$  between the absorbance values and their mean in the wavenumber range  $FFU_m$  to  $FFL_m$ . Denote the result by  $SRMS_m$ .

E.2.5 For each analytical region  $m$ , calculate the quantity

$$FM_m = SRMS_m (FFU_m - FFL_m) / BAV_m$$

E.2.6 If only the  $m^{\text{th}}$  analytical region is used to calculate the concentration of the  $i^{\text{th}}$  analyte, set  $FRU_i = FM_m$ .

E.2.7 If a number  $p_i$  of analytical regions are used to calculate the concentration of the  $i^{\text{th}}$  analyte, set  $FRU_i$  equal to the weighted mean of the appropriate  $FM_m$  values calculated above. Mathematically, if the set of analytical regions employed is  $\{m'\}$ , then

$$FRU_i = \sum_{k \in \{m'\}} W_{ik} FM_k \quad (8)$$

where the  $W_{ik}$  are calculated as described in Appendix D.





## APPENDIX F

### DETERMINING FRACTIONAL CALIBRATION UNCERTAINTIES (FCU)

#### F.1 General

F.1.1 The concentrations yielded by the computerized analytical program applied to each single-compound reference spectrum are defined as the indicated standard concentrations (ISC's). The ISC values for a single compound spectrum should ideally equal the accepted standard concentration (ASC) for one analyte or interferant, and should ideally be zero for all other compounds. Variations from these results are caused by errors in the ASC values, variations from the Beer's law (or modified Beer's law) model used to determine the concentrations, and noise in the spectra. When the first two effects dominate, the systematic nature of the errors is often apparent; take steps to correct them.

F.1.2 When the calibration error appears non-systematic, apply the following method to estimate the fractional calibration uncertainty (FCU) for each compound. The FCU is defined as the mean fractional error between the ASC and the ISC for all reference spectra with non-zero ASC for that compound. The FCU for each compound shall be less than the required fractional uncertainty specified in Section 4.1.

F.1.3 The computerized analytical programs shall also be required to yield acceptably low concentrations for compounds with ISC=0 when applied to the reference spectra. The limits chosen in this Protocol are that the ISC of each reference spectrum for each analyte or interferant shall not exceed that compound's minimum measurement uncertainty (MAU or MIU).

#### F.2 Calculations

F.2.1 Apply each analytical program to each reference spectrum. Prepare a similar table as that in Figure F.1 to present the ISC and ASC values for each analyte and interferant in each reference spectrum. Maintain the order of reference file names and compounds employed in preparing Figure F.1.

F.2.2 For all reference spectra in Figure F.1, verify that the absolute value of the ISC's are less than the compound's MAU (for analytes) or MIU (for interferants).

F.2.3 For each analyte reference spectrum, calculate the quantity  $(ASC-ISC)/ASC$ . For each analyte, calculate the mean of these values (the  $FCU_i$  for the  $i^{th}$  analyte) over all reference spectra. Prepare a similar table as that in Figure F.2 to present the  $FCU_i$  and analytical uncertainty limit ( $AU_i$ ) for each analyte.

FIGURE F.1

Presentation of Accepted Standard Concentrations (ASC's)  
and Indicated Standard Concentrations (ISC's)

Compound Name	Reference Spectrum File Name	ASC (ppm)	ISC (ppm)						
			Analytes			Interferants			
			i=1.....I			j=1.....J			

FIGURE F.2

Presentation of Fractional Calibration Uncertainties (FCU's)  
and Analytical Uncertainties (AU's)

Analyte Name	FCU (%)	AU (%)

## APPENDIX G

### MEASURING NOISE LEVELS

#### G.1 General

The root-mean-square (RMS) noise level is the standard measure of noise. The RMS noise level of a contiguous segment of a spectrum is the RMSD between the absorbance values that form the segment and the mean value of the segment (see Appendix A).

#### G.2 Calculations

G.2.1 Evacuate the absorption cell or fill it with UPC grade nitrogen at approximately one atmosphere total pressure.

G.2.2 Record two single beam spectra of signal integration period  $t_{ss}$ .

G.2.3 Form the double beam absorption spectrum from these two single beam spectra, and calculate the noise level  $RMS_{sm}$  in the  $M$  analytical regions.



## APPENDIX H

### DETERMINING SAMPLE ABSORPTION PATHLENGTH ( $L_s$ ) AND FRACTIONAL ANALYTICAL UNCERTAINTY (FAU)

#### H.1 General

Reference spectra recorded at absorption pathlength ( $L_R$ ), gas pressure ( $P_R$ ), and gas absolute temperature ( $T_R$ ) may be used to determine analyte concentrations in samples whose spectra are recorded at conditions different from that of the reference spectra, i.e., at absorption pathlength ( $L_s$ ), absolute temperature ( $T_s$ ), and pressure ( $P_s$ ). Appendix H describes the calculations for estimating the fractional uncertainty (FAU) of this practice. It also describes the calculations for determining the sample absorption pathlength from comparison of CTS spectra, and for preparing spectra for further instrumental and procedural checks.

H.1.1 Before sampling, determine the sample absorption pathlength using least squares analysis. Determine the ratio  $L_s/L_R$  by comparing the spectral sets {R1} and {R3}, which are recorded using the same CTS at  $L_s$  and  $L_R$ , and  $T_s$  and  $T_R$ , but both at  $P_R$ .

H.1.2 Determine the fractional analysis uncertainty (FAU) for each analyte by comparing a scaled CTS spectral set, recorded at  $L_s$ ,  $T_s$ , and  $P_s$ , to the CTS reference spectra of the same gas, recorded at  $L_R$ ,  $T_R$ , and  $P_R$ . Perform the quantitative comparison after recording the sample spectra, based on band areas of the spectra in the CTS absorbance band associated with each analyte.

#### H.2 Calculations

H.2.1 Absorption Pathlength Determination. Perform and document separate linear baseline corrections to each analytical region in the spectral sets {R1} and {R3}. Form a one-dimensional array  $\mathbf{A}_R$  containing the absorbance values from all segments of {R1} that are associated with the analytical regions; the members of the array are  $A_{R_i}$ ,  $i = 1, n$ . Form a similar one-dimensional array  $\mathbf{A}_s$  from the absorbance values in the spectral set {R3}; the members of the array are  $A_{s_i}$ ,  $i = 1, n$ . Based on the model  $\mathbf{A}_s = r\mathbf{A}_R + \mathbf{E}$ , determine the least-squares estimate of  $r'$ , the value of  $r$  which minimizes the square error  $\mathbf{E}^2$ . Calculate the sample absorption pathlength  $L_s = r'(T_s/T_R)L_R$ .

H.2.2 Fractional Analysis Uncertainty. Perform and document separate linear baseline corrections to each analytical region in the spectral sets {R1} and {R4}. Form the arrays  $\mathbf{A}_s$  and  $\mathbf{A}_R$  as described in Section H.2.1, using values from {R1} to form  $\mathbf{A}_R$ , and values from {R4} to form  $\mathbf{A}_s$ . Calculate the values

$$\text{NRMS}_E = \sqrt{\sum_{i=1}^n \left[ A_{Si} - \left( \frac{T_R}{T_S} \right) \left( \frac{L_S}{L_R} \right) \left( \frac{P_S}{P_R} \right) A_{Ri} \right]^2} \quad (9)$$

and

$$\text{IA}_{AV} = \frac{1}{2} \sum_{i=1}^n \left[ A_{Si} + \left( \frac{T_R}{T_S} \right) \left( \frac{L_S}{L_R} \right) \left( \frac{P_S}{P_R} \right) A_{Ri} \right] \quad (10)$$

The fractional analytical uncertainty is defined as

$$\text{FAU} = \frac{\text{NRMS}_E}{\text{IA}_{AV}} \quad (11)$$

## APPENDIX I

### DETERMINING FRACTIONAL MODEL UNCERTAINTIES (FMU)

#### I.1 General

To prepare analytical programs for FTIR analyses, the sample constituents must first be assumed; the calculations in this appendix, based upon a simulation of the sample spectrum, verify the appropriateness of these assumptions. The simulated spectra consist of the sum of single compound reference spectra scaled to represent their contributions to the sample absorbance spectrum; scaling factors are based on the indicated standard concentrations (ISC) and measured (sample) analyte and interferant concentrations, the sample and reference absorption pathlengths, and the sample and reference gas pressures. No band-shape correction for differences in the temperature of the sample and reference spectra gases is made; such errors are included in the FMU estimate. The actual and simulated sample spectra are quantitatively compared to determine the fractional model uncertainty; this comparison uses the reference spectra band areas and residuals in the difference spectrum formed from the actual and simulated sample spectra.

#### I.2 Calculations

I.2.1 For each analyte (with scaled concentration  $RSA_i$ ), select a reference spectrum  $SA_i$  with indicated standard concentration  $ISC_i$ . Calculate the scaling factors

$$RA_i = \frac{T_R L_S P_S RSA_i}{T_S L_R P_R ISC_i} \quad (12)$$

and form the spectra  $SAC_i$  by scaling each  $SA_i$  by the factor  $RA_i$ .

I.2.2 For each interferant, select a reference spectrum  $SI_k$  with indicated standard concentration  $ISC_k$ . Calculate the scaling factors

$$RI_k = \frac{T_R L_S P_S RSI_k}{T_S L_R P_R ISC_k} \quad (13)$$

and form the spectra  $SIC_k$  by scaling each  $SI_k$  by the factor  $RI_k$ .

I.2.3 For each analytical region, determine by visual inspection which of the spectra  $SAC_i$  and  $SIC_k$  exhibit absorbance bands within the analytical region. Subtract each spectrum  $SAC_i$  and  $SIC_k$  exhibiting absorbance from the sample spectrum  $S_s$  to form the spectrum  $SUB_s$ . To save analysis time and to avoid the introduction of unwanted noise into the subtracted spectrum, it is recommended that the calculation be made (1) only for those

spectral data points within the analytical regions, and (2) for each analytical region separately using the original spectrum  $S_s$ .

I.2.4 For each analytical region  $m$ , calculate the RMSD of  $SUB_s$  between the absorbance values and their mean in the region  $FFU_m$  to  $FFL_m$ . Denote the result by  $RMSS_m$ .

I.2.5 For each analyte  $i$ , calculate the quantity

$$FM_m = \frac{RMSS_m (FFU_m - FFL_m) AU_i DL_i}{AAI_i RSA_i} \quad (14)$$

for each analytical region associated with the analyte.

I.2.6 If only the  $m^{\text{th}}$  analytical region is used to calculate the concentration of the  $i^{\text{th}}$  analyte, set  $FMU_i = FM_m$ .

I.2.7 If a number of analytical regions are used to calculate the concentration of the  $i^{\text{th}}$  analyte, set  $FMU_i$  equal to the weighted mean of the appropriate  $FM_m$  values calculated above. Mathematically, if the set of analytical regions employed is  $\{m'\}$ , then

$$FMU_i = \sum_{k \in (m')} W_{ik} FM_k \quad (15)$$

where  $W_{ik}$  is calculated as described in Appendix D.



## APPENDIX J

### DETERMINING OVERALL CONCENTRATION UNCERTAINTIES (OCU)

The calculations in previous sections and appendices estimate the measurement uncertainties for various FTIR measurements. The lowest possible overall concentration uncertainty (OCU) for an analyte is its MAU value, which is an estimate of the absolute concentration uncertainty when spectral noise dominates the measurement error. However, if the product of the largest fractional concentration uncertainty (FRU, FCU, FAU, or FMU) and the measured concentration of an analyte exceeds the MAU for the analyte, then the OCU is this product. In mathematical terms, set  $OFU_i = \text{MAX}\{\text{FRU}_i, \text{FCU}_i, \text{FAU}_i, \text{FMU}_i\}$  and  $OCU_i = \text{MAX}\{\text{RSA}_i * \text{OFU}_i, \text{MAU}_i\}$ .



## APPENDIX K

### SPECTRAL DE-RESOLUTION PROCEDURES

#### K.1 General.

High resolution reference spectra can be converted into lower resolution standard spectra for use in quantitative analysis of sample spectra. This is accomplished by truncating the number of data points in the original reference sample and background interferograms.

De-resolved spectra must meet the following requirements to be used in quantitative analysis.

(a) The resolution must match the instrument sampling resolution. This is verified by comparing a de-resolved CTS spectrum to a CTS spectrum measured on the sampling instrument.

(b) The Fourier transformation of truncated interferograms (and their conversion to absorbance spectra) is performed using the same apodization function (and other mathematical corrections) used in converting the sample interferograms into absorbance spectra.

#### K.2 Procedures

This section details three alternative procedures using two different commercially available software packages. A similar procedure using another software package is acceptable if it is based on truncation of the original reference interferograms and the results are verified by Section K.3.

K.2.1 KVB/Analect Software Procedure - The following example converts a  $0.25\text{ cm}^{-1}$  100 ppm ethylene spectrum (cts0305a) to  $1\text{ cm}^{-1}$  resolution. The  $0.25\text{ cm}^{-1}$  CTS spectrum was collected during the EPA reference spectrum program on March 5, 1992. The original data (in this example) are in KVB/Analect FX-70 format.

(i) **decomp cts0305a.aif,0305dres,1,16384,1**

"decomp" converts cts0305a to an ASCII file with name 0305dres. The resulting ASCII interferogram file is truncated to 16384 data points. Convert background interferogram (bkg0305a.aif) to ASCII in the same way.

(ii) **compose 0305dres,0305dres.aif,1**

"Compose" transforms truncated interferograms back to spectral format.

(iii) **IG2SP 0305dres.aif,0305dres.dsf,3,1,low  $\text{cm}^{-1}$ ,high  $\text{cm}^{-1}$**

"IG2SP" converts interferogram to a single beam spectrum using Norton-Beer medium apodization, 3, and no zero filling, 1.

De-resolved interferograms should be transformed using the same apodization and zero filling that will be used to collect sample spectra. Choose the desired low and high frequencies, in cm<sup>-1</sup>. Transform the background interferogram in the same way.

(iv) **DVDR 0305dres.dsf,bkg0305a.dsf,0305dres.dlf**

"DVDR" ratios the transformed sample spectrum against the background.

(v) **ABSB 0305dres.dlf,0305dres.dlf**

"ABSB" converts the spectrum to absorbance.

The resolution of the resulting spectrum should be verified by comparison to a CTS spectrum collected at the nominal resolution. Refer to Section K.3.

K.2.2 Alternate KVB/Analect Procedure -- In either DOS (FX-70) or Windows version (FX-80) use the "Extract" command directly on the interferogram.

(i) **EXTRACT CTS0305a.aif,0305dres.aif,1,16384**

"Extract" truncates the interferogram to data points from to 16384 (or number of data points for desired nominal resolution). Truncate background interferogram in the same way.

(ii) Complete steps (iii) to (v) in Section K.2.1.

K.2.3 Grams™ Software Procedure - Grams™ is a software package that displays and manipulates spectra from a variety of instrument manufacturers. This procedure assumes familiarity with basic functions of Grams™.

This procedure is specifically for using Grams to truncate and transform reference interferograms that have been imported into Grams from the KVB/Analect format. Table K-1 shows data files and parameter values that are used in the following procedure.

The choice of all parameters in the ICOMPUTE.AB call of step 3 below should be fixed to the shown values, with the exception of the "Apodization" parameter. This parameter should be set (for both background and sample single beam conversions) to the type of apodization function chosen for the de-resolved spectral library.



### K.3 Verification of New Resolution

K.3.1 Obtain interferograms of reference sample and background spectra. Truncate interferograms and convert to absorbance spectra of desired nominal resolution.

K.3.2 Document the apodization function, the level of zero filling, the number of data points, and the nominal resolution of the resulting de-resolved absorbance spectra. Use the identical apodization and level of zero filling when collecting sample spectra.

K.3.3 Perform the same de-resolution procedure on CTS interferograms that correspond with the reference spectra (reference CTS) to obtain de-resolved CTS standard spectra (CTS standards). Collect CTS spectra using the sampling resolution and the FTIR system to be used for the field measurements (test CTS). If practical, use the same pathlength, temperature, and standard concentration that were used for the reference CTS. Verify, by the following procedure that CTS linewidths and intensities are the same for the CTS standards and the test CTS.

K.3.4 After applying necessary temperature and pathlength corrections (document these corrections), subtract the CTS standard from the test CTS spectrum. Measure the RMSD in the resulting subtracted spectrum in the analytical region(s) of the CTS band(s). Use the following equation to compare this RMSD to the test CTS band area. The ratio in equation 7 must be no greater than 5 percent (0.05).

$$\frac{RMSS_i \times n(FFU_i - FFL_i)}{A_{CTS-test}} \leq .05 \quad (16)$$

RMSS=RMSD in the  $i^{th}$  analytical region in subtracted result, test CTS minus CTS standard.

$n$ =number of data points per  $cm^{-1}$ . Exclude zero filled points.

$FFU_i$  &= $FFL_i$ =The upper and lower limits ( $cm^{-1}$ ), respectively, of the analytical region.

$A_{test-CTS}$ =band area in the  $i^{th}$  analytical region of the test CTS.

D-3 EPA METHOD 25A





---

---

**EMISSION MEASUREMENT TECHNICAL INFORMATION CENTER  
NSPS TEST METHOD**

---

---

**METHOD 25A-DETERMINATION OF TOTAL GASEOUS ORGANIC  
CONCENTRATION USING A FLAME IONIZATION ANALYZER**

**1. Applicability and Principle**

**1.1 Applicability.** This method applies to the measurement of total gaseous organic concentration of vapors consisting primarily of alkanes, alkenes, and/or arenes (aromatic hydrocarbons). The concentration is expressed in terms of propane (or other appropriate organic calibration gas) or in terms of carbon.

**1.2 Principle.** A gas sample is extracted from the source through a heated sample line, if necessary, and glass fiber filter to a flame ionization analyzer (FIA). Results are reported as volume concentration equivalents of the calibration gas or as carbon equivalents.

**2. Definitions**

**2.1 Measurement Systems.** The total equipment required for the determination of the gas concentration. The system consists of the following major subsystems:

**2.1.1 Sample Interface.** That portion of the system that is used for one or more of the following: sample acquisition, sample transportation, sample conditioning, or protection of the analyzer from the effects of the stack effluent.

**2.1.2 Organic Analyzer.** That portion of the system that senses organic concentration and generates an output proportional to the gas concentration.

**2.2 Span Value.** The upper limit of a gas concentration measurement range that is specified for affected source categories in the applicable part of the regulations. The span value is established in the applicable regulation and is usually 1.5 to 2.5 times the applicable emission limit. If no span value is provided, use a span value equivalent to 1.5 to 2.5 times the expected concentration. For convenience, the span value should correspond to 100 percent of the recorder scale.

**2.3 Calibration Gas.** A known concentration of a gas in an appropriate diluent gas.

**2.4 Zero Drift.** The difference in the measurement system response to a zero level calibration gas before and after a stated period of operation during which no unscheduled maintenance, repair, or adjustment took place.

**2.5 Calibration drift.** The difference in the measurement system response to a midlevel calibration gas before and after a stated period of operation during which no unscheduled maintenance, repair or adjustment took place.

**2.6 Response Time.** The time interval from a step change in pollutant

concentration at the inlet to the emission measurement system to the time at which 95 percent of the corresponding final value is reached as displayed on the recorder.

**2.7 Calibration Error.** The difference between the gas concentration indicated by the measurement system and the known concentration of the calibration gas.

### **3. Apparatus.**

A schematic of an acceptable measurement system is shown in Figure 25A-1. The essential components of the measurement system are described below:

**3.1 Organic Concentration Analyzer.** A flame ionization analyzer (FIA) capable of meeting or exceeding the specifications in this method.

**3.2 Sample Probe.** Stainless steel, or equivalent, three-hole rake type. Sample holes shall be 4 mm in diameter or smaller and located at 16.7, 50, and 83.3 percent of the equivalent stack diameter. Alternatively, a single opening probe may be used so that a gas sample is collected from the centrally located 10 percent area of the stack cross-section.

**3.3 Sample Line.** Stainless steel or Teflon \* tubing to transport the sample gas to the analyzer. The sample line should be heated, if necessary, to prevent condensation in the line.

**3.4 Calibration Valve Assembly.** A three way valve assembly to direct the zero and calibration gases to the analyzers is recommended. Other methods, such as quick-connect lines, to route calibration gas to the analyzers are applicable.

**3.5 Particulate Filter.** An in-stack or an out-of-stack glass fiber filter is recommended if exhaust gas particulate loading is significant. An out-of-stack filter should be heated to prevent any condensation.

\* Mention of trade names or specific products does not constitute endorsement by the Environmental Protection Agency.

**3.6 Recorder.** A strip-chart recorder, analog computer, or digital recorder for recording measurement data. The minimum data recording requirement is one measurement value per minute, Note: This method is often applied in highly explosive areas. Caution and care should be exercised in choice of equipment and installation.

### **4. Calibration and Other Gases.**

Gases used for calibrations, fuel, and combustion air (if required) are contained in compressed gas cylinders. Preparation of calibration gases shall be done according to the procedure in Protocol No. 1, listed in Citation 2 of Bibliography. Additionally, the manufacturer of the cylinder should provide a recommended shelf life for each calibration gas cylinder over which the concentration does not change more than  $\pm 2$  percent from the certified value. For calibration gas values not generally available (i.e., organics between 1 and 10 percent by volume), alternative methods for preparing calibration gas mixtures, such as dilution systems, may be used with prior approval of the Administrator.

Calibration gases usually consist of propane in air or nitrogen and are determined in terms of the span value. Organic compounds other than propane can

be used following the above guidelines and making the appropriate corrections for response factor.

**4.1 Fuel.** A 40 percent H<sub>2</sub>/60 percent N<sub>2</sub> gas mixture is recommended to avoid an oxygen synergism effect that reportedly occurs when oxygen concentration varies significantly from a mean value.

**4.2 Zero Gas.** High purity air with less than 0.1 parts per million by volume (ppmv) of organic material (propane or carbon equivalent) or less than 0.1 percent of the span value, whichever is greater.

**4.3 Low-level Calibration Gas.** An organic calibration gas with a concentration equivalent to 25 to 35 percent of the applicable span value.

**4.4 Mid-level Calibration Gas.** An organic calibration gas with a concentration equivalent to 45 to 55 percent of the applicable span value.

**4.5 High-level Calibration Gas.** An organic calibration gas with a concentration equivalent to 80 to 90 percent of the applicable span value.

## **5. Measurement System Performance Specifications**

**5.1 Zero Drift.** Less than ±3 percent of the span value.

**5.2 Calibration Drift.** Less than ±3 percent of span value.

**5.3 Calibration Error.** Less than ±5 percent of the calibration gas value.

## **6. Pretest Preparations**

**6.1 Selection of Sampling Site.** The location of the sampling site is generally specified by the applicable regulation or purpose of the test; i.e., exhaust stack, inlet line, etc. The sample port shall be located at least 1.5 meters or 2 equivalent diameters upstream of the gas discharge to the atmosphere.

**6.2 Location of Sample Probe.** Install the sample probe so that the probe is centrally located in the stack, pipe, or duct and is sealed tightly at the stack port connection.

**6.3 Measurement System Preparation.** Prior to the emission test, assemble the measurement system following the manufacturer's written instructions in preparing the sample interface and the organic analyzer. Make the system operable.

FIA equipment can be calibrated for almost any range of total organics concentrations. For high concentrations of organics (>1.0 percent by volume as propane) modifications to most commonly available analyzers are necessary. One accepted method of equipment modification is to decrease the size of the sample to the analyzer through the use of a smaller diameter sample capillary. Direct and continuous measurement of organic concentration is a necessary consideration when determining any modification design.

**6.4 Calibration Error Test.** Immediately prior to the test series, (within 2 hours of the start of the test) introduce zero gas and high-level calibration gas at the calibration valve assembly. Adjust the analyzer output to the appropriate levels, if necessary. Calculate the predicted response for the low-level and

mid-level gases based on a linear response line between the zero and high-level responses. Then introduce low-level and mid-level calibration gases successively to the measurement system. Record the analyzer responses for low-level and mid-level calibration gases and determine the differences between the measurement system responses and the predicted responses. These differences must be less than 5 percent of the respective calibration gas value. If not, the measurement system is not acceptable and must be replaced or repaired prior to testing. No adjustments to the measurement system shall be conducted after the calibration and before the drift check (Section 7.3). If adjustments are necessary before the completion of the test series, perform the drift checks prior to the required adjustments and repeat the calibration following the adjustments. If multiple electronic ranges are to be used, each additional range must be checked with a mid-level calibration gas to verify the multiplication factor.

**6.5 Response Time Test.** Introduce Zero gas into the measurement system at the calibration valve assembly. When the system output has stabilized, switch quickly to the high-level calibration gas. Record the time from the concentration change to the measurement system response equivalent to 95 percent of the step change. Repeat the test three times and average the results.

## 7. Emission Measurement Test Procedure

**7.1 Organic Measurement.** Begin sampling at the start of the test period, recording time and any required process information as appropriate. In particular, note on the recording chart periods of process interruption or cyclic operation.

**7.2 Drift Determination.** Immediately following the completion of the test period and hourly during the test period, reintroduce the zero and mid-level calibration gases, one at a time, to the measurement system at the calibration valve assembly. (Make no adjustments to the measurement system until after both the zero and calibration drift checks are made.) Record the analyzer response. If the drift values exceed the specified limits, invalidate the test results preceding the check and repeat the test following corrections to the measurement system. Alternatively, recalibrate the test measurement system as in Section 6.4 and report the results using both sets of calibration data (i.e., data determined prior to the test period and data determined following the test period).

## 8. Organic Concentration calculations

Determine the average organic concentration in terms of ppmv as propane or other calibration gas. The average shall be determined by the integration of the output recording over the period specified in the applicable regulation. If results are required in terms of ppmv as carbon, adjust measured concentrations using Equation 25A-1.

$$C_c = KC_{meas} \quad \text{Eq. 25A-1}$$

Where:

- $C_c$  = Organic concentration as carbon, ppmv.  
 $C_{meas}$  = Organic concentration as measured, ppmv.  
 $K$  = Carbon equivalent correction factor.

- K = 2 for ethane.
- K = 3 for propane.
- K = 4 for butane.
- K = Appropriate response factor for other organic calibration gases.

## 9. Bibliography

1. Measurement of Volatile Organic Compounds-Guideline Series. U.S. Environmental Protection Agency. Research Triangle Park, NC. Publication No. EPA-450/2-78-041. June 1978. p. 46-54.
2. Traceability Protocol for Establishing True Concentrations of Gases Used for Calibration and Audits of Continuous Source Emission Monitors (Protocol No. 1). U.S. Environmental Protection Agency, Environmental Monitoring and Support Laboratory. Research Triangle Park, NC. June 1978.
3. Gasoline Vapor Emission Laboratory Evaluation-Part 2. U.S. Environmental Protection Agency, Office of Air Quality Planning and Standards. Research Triangle Park, NC. EMB Report No. 75-GAS-6. August 1975.

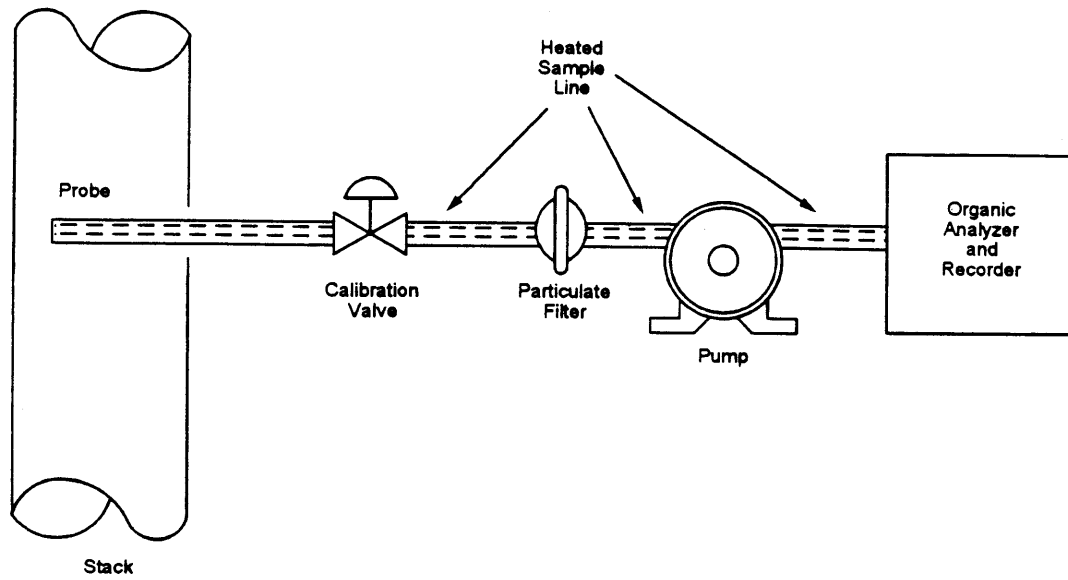

Figure 25A-1. Organic Concentration Measurement System.

D-4 EPA DRAFT METHOD 205





---

---

**EMISSION MEASUREMENT TECHNICAL INFORMATION CENTER  
TEST METHOD**

---

---

DRAFT--DO NOT CITE OR QUOTE

The EPA proposes to amend Title 40, Chapter I, Part 51 of the Code of Federal Regulations as follows:

1. The authority citation for Part 51 continues to read as follows:  
Authority: Section 110 of the Clean Air Act as amended. 42 U.S.C. 7410.

2. Appendix M, Table of Contents is amended by adding an entry to read as follows:

Method 205--Verification of Gas Dilution Systems for Field Instrument Calibrations

3. By adding Method 205 to read as follows:

**Method 205 - Verification of Gas Dilution Systems  
for Field Instrument Calibrations**

**1. INTRODUCTION**

**1.1 Applicability.** A gas dilution system can provide known values of calibration gases through controlled dilution of high-level calibration gases with an appropriate dilution gas. The instrumental test methods in 40 CFR Part 60 -- e.g., Methods 3A, 6C, 7E, 10, 15, 16, 20, 25A and 25B -- require on-site, multi-point calibration using gases of known concentrations. A gas dilution system that produces known low-level calibration gases from high-level calibration gases, with a degree of confidence similar to that for Protocol<sup>1</sup> gases, may be used for compliance tests in lieu of multiple calibration gases when the gas dilution system is demonstrated to meet the requirements of this method. The Administrator may also use a gas dilution system in order to produce a wide range of Cylinder Gas Audit concentrations when conducting performance specifications according to Appendix F, 40 CFR Part 60. As long as the acceptance criteria of this method are met, this method is applicable to gas dilution systems using any type of dilution technology, not solely the ones mentioned in this method.

**1.2 Principle.** The gas dilution system shall be evaluated on one analyzer once during each field test. A precalibrated analyzer is chosen, at the discretion of the source owner or operator, to demonstrate that the gas dilution system produces predictable gas concentrations spanning a range of concentrations. After meeting the requirements of this method, the remaining analyzers may be calibrated with the dilution system in accordance to the requirements of the applicable method for the duration of the field test. In Methods 15 and 16, 40 CFR Part 60, Appendix A, reactive compounds may be lost in the gas dilution system. Also, in Methods 25A and 25B, 40 CFR Part 60, Appendix A, calibration with target compounds other than propane is allowed. In these cases, a laboratory evaluation is required once per year in order to assure the Administrator that the system will dilute these reactive gases without significant loss. **Note:** The laboratory evaluation is required only if the source owner or operator plans to utilize the dilution system to prepare gases mentioned above as being reactive.

**2. SPECIFICATIONS**

**2.1 Gas Dilution System.** The gas dilution system shall produce calibration gases whose measured values are within  $\pm 2$  percent of the predicted values. The predicted values are calculated based on the certified concentration of the supply gas (Protocol gases, when available, are recommended for their accuracy) and the gas flow rates (or dilution ratios) through the gas dilution system.

---

Prepared by **Emission Measurement Branch**  
Technical Support Division, OAQPS, EPA

**EMTIC TM-205**

**2.1.1** The gas dilution system shall be recalibrated once per calendar year using NIST-traceable primary flow standards with an uncertainty  $\leq 0.25$  percent. A label shall be affixed at all times to the gas dilution system listing the date of the most recent calibration, the due date for the next calibration, and the person or manufacturer who carried out the calibration. Follow the manufacturer's instructions for the operation and use of the gas dilution system. A copy of the manufacturer's instructions for the operation of the instrument, as well as the most recent recalibration documentation shall be made available for the Administrator's inspection upon request.

**2.1.2** Some manufacturers of mass flow controllers recommend that flow rates below 10 percent of flow controller capacity be avoided; check for this recommendation and follow the manufacturer's instructions. One study has indicated that silicone oil from a positive displacement pump produces an interference in  $\text{SO}_2$  analyzers utilizing ultraviolet fluorescence; follow laboratory procedures similar to those outlined in Section 3.2 in order to demonstrate the significance of any resulting effect on instrument performance.

**2.2 High-Level Supply Gas.** An EPA Protocol calibration gas is recommended, due to its accuracy, as the high-level supply gas.

**2.3 Mid-Level Supply Gas.** An EPA Protocol gas shall be used as an independent check of the dilution system. The concentration of the mid-level supply gas shall be within 10 percent of one of the dilution levels tested in Section 3.2.

### **3. PERFORMANCE TESTS**

**3.1 Laboratory Evaluation (Optional).** If the gas dilution system is to be used to formulate calibration gases with reactive compounds (Test Methods 15, 16, and 25A/25B (only if using a calibration gas other than propane during the field test) in 40 CFR Part 60, Appendix A), a laboratory certification must be conducted once per calendar year for each reactive compound to be diluted. In the laboratory, carry out the procedures in Section 3.2 on the analyzer required in each respective test method to be laboratory certified (15, 16, or 25A and 25B for compounds other than propane). For each compound in which the gas dilution system meets the requirements in Section 3.2, the source must provide the laboratory certification data for the field test and in the test report.

**3.2 Field Evaluation (Required).** The gas dilution system shall be evaluated at the test site with an analyzer or monitor chosen by the source owner or operator. It is recommended that the source owner or operator choose a precalibrated instrument with a high level of precision and accuracy for the purposes of this test. This method is not meant to replace the calibration requirements of test methods. In addition to the requirements in this method, all the calibration requirements of the applicable test method must also be met.

**3.2.1** Prepare the gas dilution system according to the manufacturer's instructions. Using the high-level supply gas, prepare, at a minimum, two dilutions within the range of each dilution device utilized in the dilution system (unless, as in critical orifice systems, each dilution device is used to make only one dilution; in that case, prepare one dilution for each dilution device). Dilution device in this method refers to each mass flow controller, critical orifice, capillary tube, positive displacement pump, or any other device which is used to achieve gas dilution.

**3.2.2** Calculate the predicted concentration for each of the dilutions based on the flow rates through the gas dilution system (or the dilution ratios) and the certified concentration of the high-level supply gas.

**3.2.3** Introduce each of the dilutions from Section 3.2.1 into the analyzer or monitor one at a time and determine the instrument response for each of the dilutions.

**3.2.4** Repeat the procedure in Section 3.2.3 two times, i.e., until three injections are made at each dilution level. Calculate the average instrument response for each triplicate injection at each dilution level. No single

injection shall differ by more than  $\pm 2$  percent from the average instrument response for that dilution. **3.2.5** For each level of dilution, calculate the difference between the average concentration output recorded by the analyzer and the predicted concentration calculated in Section 3.2.2. The average concentration output from the analyzer shall be within  $\pm 2$  percent of the predicted value.

**3.2.6** Introduce the mid-level supply gas directly into the analyzer, bypassing the gas dilution system. Repeat the procedure twice more, for a total of three mid-level supply gas injections. Calculate the average analyzer output concentration for the mid-level supply gas. The difference between the certified concentration of the mid-level supply gas and the average instrument response shall be within  $\pm 2$  percent.

**3.3** If the gas dilution system meets the criteria listed in Section 3.2, the gas dilution system may be used throughout that field test. If the gas dilution system fails any of the criteria listed in Section 3.2, and the tester corrects the problem with the gas dilution system, the procedure in Section 3.2 must be repeated in its entirety and all the criteria in Section 3.2 must be met in order for the gas dilution system to be utilized in the test.

#### **4. REFERENCES**

1. "EPA Traceability Protocol for Assay and Certification of Gaseous Calibration Standards," EPA-600/R93/224, Revised September 1993.



97-MP74.05

---

## Validation of EPA FTIR Method For Measuring HCl

**Thomas J. Geyer**

Midwest Research Institute, Suite 350, 401 Harrison Oaks Boulevard, Cary, North Carolina 27513

**Grant M. Plummer**

Rho Squared, 703 Ninth Street, Suite 183, Durham, North Carolina 27705

### Introduction

In 1997 EPA is preparing to publish a sampling method (Draft Method 320)<sup>1</sup> based on the use of Fourier transform infrared (FTIR) spectroscopy to measure emissions of hazardous air pollutants (HAPs). This method establishes sampling procedures for measuring HAPs and employs analytical procedures in the EPA FTIR Protocol.<sup>2</sup>

In 1996 EPA conducted a field test at a source with HCl emissions. The test goal was to use the FTIR Draft Method 320 to measure vapor phase pollutants at this source. Measurements were conducted on the inlet and outlet of a control device. Hydrogen chloride (HCl) was a target pollutant for this source and, for this reason, some samples were spiked from a cylinder containing a standard concentration of 103 ppm HCl. Results of HCl measurements are presented along with a Method 301<sup>3</sup> statistical analysis of spiked and unspiked samples, and a comparison of results obtained using EPA reference spectra and results obtained using spectra of the HCl gas standard to measure the sample concentrations.

### Experimental

The source tested in this project was a coal burning process with a relatively low moisture content (3 to 4% by volume). Flue gas temperatures were between 400 and 500°F. The principal components of the gas stream were water vapor, CO<sub>2</sub>, SO<sub>2</sub>, and NO.

### Sampling System

The sampling system is depicted in Figure 1. The sample was extracted through a 4-ft long, 0.5-in diameter stainless steel probe. Sample was transported through heated 3/8-in Teflon line using a KNF Neuberger heated head sample pump (Model NO35 ST.11I). A Balston particulate filter (holder Model Number 30-25, filter element Model Number 100-25-BH, 99 percent removal efficiency at 0.1 µm) was connected in-line at the outlet of the sample probe. The sample line was heat wrapped and insulated. Temperature controllers were used to monitor and regulate the sample line temperature at about 350° F. The stainless steel manifold contained 3/8-in tubing, rotameters and 4-way valves to monitor and control the sample flow to the FTIR gas cell. The manifold temperature was maintained between 300 to 310°F.

The FTIR system included an Analect instruments Model RFX-40 interferometer equipped with a broad band MCT detector. Samples were contained in an Infrared Analysis Model D22H variable path gas cell. The cell temperature was maintained at 250°F.

### Sampling Procedure

A series of discreet batch samples was collected by filling the cell above ambient pressure and closing the inlet valve to isolate the sample. An outlet valve was briefly opened to vent the sample to ambient pressure. The spectrum of the static sample was recorded. Then the cell was evacuated for the next sample. Each spectrum consisted of 50 co-added scans. The minimum time between consecutive samples was about 2 minutes. Inlet and outlet runs were conducted at the same time: the two location were sampled alternately with the one FTIR system. The minimum time between consecutive measurements was about 3 to 5 minutes.

### Path Length Determinations

Two path lengths were used in this test. The cell was adjusted to 40 beam passes for the first two test runs and reduced to 20 beam passes for a third test run. The number of beam passes was measured by shining a He/Ne laser through the optical path and observing the number of laser spots on the field mirror. The path lengths in meters were determined by comparing CTS EPA reference spectra to the CTS spectra collected at each path length.

Absorption path lengths were determined from a comparison of the field test CTS spectra and EPA library CTS spectra of ethylene ( $C_2H_4$ ). For high temperature spectra, the EPA library interferograms cts0115a.aif and bkg0115a.aif were de-resolved to the appropriate spectral resolution (either 1 or 2  $cm^{-1}$ ) according to the procedures of reference 2 (Appendix K). The same procedure was used to generate low-temperature spectra from the original interferometric data in the EPA library files cts0829a.aif and bkg0829a.aif. The resulting files were used in least squares fits to the appropriate field CTS spectra (see reference 2, Appendix H) in two regions (the FP, or "fingerprint" region from 790 to 1139  $cm^{-1}$  and the CH, or "CH-stretch region" from 2760 to 3326  $cm^{-1}$ ). The fit results for each region, test, and set of test sampling conditions were averaged. They and their average uncertainties are presented in Table 1. The CH values were used in analytical region 4 where HCl was measured.

### Analyte Spiking

Draft Method 320<sup>1</sup> contains a procedure for spiking the flue gas with one or more of the target analytes. The spike procedure closely follows Section 6.3 of reference 3. The primary purpose of analyte spiking is to provide a quality assurance check on the sampling system to determine if analyte losses occur in transport to the analyzer. A second purpose is to test the analytical program to verify that the analyte(s) can be measured in the sample matrix. If at least 12 (independent) spiked and 12 (independent) unspiked samples are measured then a Method 301 statistical analysis can be performed on the results to "validate" the method.

Figure 1 shows the sampling configuration used for the analyte spike. This procedure is described in detail elsewhere<sup>1</sup>. In this test, a measured flow of the gas standard was preheated to the sample line temperature before being introduced into the extracted flue gas at the back of the probe. The spiked sample then passed through all of the sample components to the gas cell where the spectrum was recorded. A series of unspiked samples was measured, the spike was turned on and then a complete

series of spiked samples was measured. The spike then was turned off to make additional unspiked measurements. Ideally, the spike comprises 1/10 or less of the sample mixture. The dilution is estimated by comparing the spike flow to the total flow, but the actual dilution is determined measuring a tracer ( $\text{SF}_6$ ) concentration in the spiked samples and comparing that to tracer concentration in the undiluted gas standard.<sup>1</sup>

Usually the tracer is spiked with the analyte standard. In this test the  $\text{SF}_6$  standard and HCl standard were contained in separate cylinders so the  $\text{SF}_6$  was spiked first, then the HCl was spiked, and finally the  $\text{SF}_6$  was spiked again. The total sample flow stayed constant during the entire sampling period. The spike flow was also held constant to insure that the dilution ratio was the same when the  $\text{SF}_6$  was spiked as when the HCl was spiked.

### **Quantitative Analysis**

FTIR analysis is performed in two steps: (1) collecting spectra of samples, and (2) analyzing the spectra to determine concentrations of detected compounds. The quantitative analysis step usually is performed with an automated program that relates sample absorbance intensities to absorbance intensities at known concentrations in reference spectra.<sup>2</sup> The Protocol<sup>2</sup> describes procedures for preparing reference spectra and Method 320<sup>1</sup> requires the analyst to use reference spectra prepared with the Protocol procedures. To date, the only existing set of reference spectra for HCl and most Clean Air Act HAPs is in the EPA FTIR spectral library (<http://info.arnold.af.mil/epa/welcome.htm>).

The Calibration Transfer Standard<sup>2</sup> is the key requirement in using reference spectra for quantitative analysis. CTS spectra help the analyst characterize differences in resolution, path length, temperature, and sample pressure between the instrument system used to collect reference spectra and the system used to collect the sample spectra. Table 1 illustrates how the CTS spectra were used to determine the optical path lengths for the system used in this test. The HCl reference spectra were de-resolved in the same way as the CTS reference spectra before they were used in the quantitative analysis.

References 4 through 8 comprise a thorough description of one technique for analyzing FTIR absorbance spectra. Two different analytical routines were used in this study. The first was prepared by Rho Squared using the programming language ARRAY BASIC™ (GRAMS,™ Version 3.02, Galactic Industries Corporation, Salem, New Hampshire). The "classical least squares" (CLS) or "K-Matrix" technique and the associated computer program "4FIT" are described in Reference 9. The terminology and basic analytical approach employed in this work are described in the "EPA FTIR Protocol" (Reference 2). The second routine used the K-matrix analytical program "Multicomp" version 6.0 (Analect Instruments).

The two analyses were performed independently by different analysts and then compared without modification.

### **Reference Spectra**

The program "4FIT" used as input EPA FTIR library spectra of HCl de-resolved to  $1 \text{ cm}^{-1}$  and normalized for absolute temperature, concentration, and absorption path length. The resulting files were

averaged to provide a "reduced absorptivity" (see Reference 9), which was stored in the spectral file 097.alf and employed in all subsequent HCl analyses. The HCl analysis was applied to the de-resolved EPA library HCl spectra to determine the fractional calibration uncertainty (FCU), which is presented in Table 2.

During the test MRI recorded spectra of samples taken directly from an HCl cylinder standard (103 ppm HCl in nitrogen,  $\pm 5\%$  accuracy from Scott Specialty Gases). Four independent HCl "calibration" spectra were measured at each of the two instrument configurations used to collect the data presented in Figures 2 and 3. The Fractional Calibration Uncertainty for each set of four spectra and the analytical region for the "Multicomp" analysis is presented in Table 2.

Even though the two sets of results are identified by the program names "4FIT" and "Multicomp," it is important to note that the "Multicomp" results were reproduced by the program "4FIT" when the HCl calibration spectra were used as input for "4FIT." Therefore, any differences in the analyses are not attributable to the programs, but to the use of different input spectra.

## Results

### HCl Concentrations

Table 3 summarizes results from the three test runs at the two locations. The agreement between the "4FIT" and the "Multicomp" analyses is very good except for the third run. This run was conducted after the path length had been decreased from 40 to 20 laser passes.

The two comparisons plotted in Figures 2 and 3 are indicated in Table 3. The Run 2 outlet results (Figure 2) are typical of those obtained for the Run 2 inlet results recorded on the same day and the Run 1 inlet and outlet results recorded a day earlier. The close agreement was typical also for two data sets collected at another field test in one test run. For 3 of the 6 data sets presented in Table 3, the results obtained with program "4FIT," using de-resolved EPA library reference spectra and the CTS-derived absorption path lengths, are nearly identical (within the  $4\sigma$  uncertainty) to those obtained using "Multicomp," which employed the field HCl calibration standard spectra without an explicit absorption path length determination. The average percent difference of the Run 2 inlet results was slightly higher than the  $4\sigma$  uncertainty, but this percent difference corresponded to an average difference of 1.7 ppm. The error bars in Figures 2 and 3 correspond to the  $4\sigma$  statistical uncertainties in the "4FIT" HCl concentrations.

### Method 301 Analysis

Tables 4 and 5 present the results of the method 301 statistical analysis of the spiked and unspiked "4FIT" and "Multicomp" Run 3 outlet results, respectively. Note that the nearly constant difference of about 19 percent in the two analyses has almost no effect on the Method 301 statistical analyses, which indicate no significant bias in the HCl measurements. This is because the statistical treatment analyzes differences between spiked and unspiked measurements and compares the differences to an expected value of the spike. Since the same offset is apparent in the "Multicomp" analysis of both the spiked and unspiked results, the calculated bias is not affected.



This is another indication that the difference in the "4FIT" and "Multicomp" run 3 results is not due to a measurement or analytical error. It is likely due either to an anomaly in the Run 3 path length determination for the CH stretch region or to an error associated with using the HCl "calibration spectra as input for the "Multicomp" program. As stated above, the "4FIT" program reproduced the "Multicomp" results when using the HCl "calibration" spectra as input.

## Discussion

The uncertainties for the four data sets in Runs 1 and 2 are approximately equal to the small differences between the "4FIT" and "Multicomp" results. The excellent agreement of the two analyses is noteworthy for several reasons. HCl is notoriously difficult both in terms of sampling and data analysis, due (respectively) to the compound's high chemical reactivity and the details of the infrared spectrum which make the analysis susceptible to instrument resolution errors. The results also provide a direct comparison between two fundamentally different analytical approaches, one relying on *in situ* calibration of the instrument using actual calibration gas standards, and the other using the calibration transfer concept.

This comparison is somewhat clouded by the results depicted in Figure 3, which show the HCl concentration determined during Run 3 at the outlet. These are also typical of the results for another data set recorded on the same day at the inlet. Unlike the Runs 1 and 2 data, the Run 3 data indicate a statistically meaningful difference of approximately 18% between the "4FIT" and "Multicomp" results. We stress that this difference is **not** attributable to errors in the computer programs, which produced reliable results in these and many independent test cases. Rather, the difference seems to be related to an anomaly in the absorption path length determinations presented in Table 1. Note that the CTS-derived absorption path length for (nominally) 20 passes, corresponding to the Run 3 data, are 10.2 meters for the CH-stretch and "fingerprint" (FP) analytical regions. The difference between the CH and FP results is much larger for this particular day of testing than on the other two test days, represented in the table by the 16- and 40- pass results. (It is also anomalous with respect to results obtained using the same instrument in another field test completed within nine days of the testing addressed here.) Moreover, were the average of the CH and FP region values (12.2 meters) used for the HCl concentration values rather than the CH region value of 10.2 meters, the level of agreement between the two sets of analytical results for the Run 3 data would be comparable to that of the Run 1 and 2 data discussed immediately above.

We have attempted to determine the cause of this difference by considering a number of possible operational and instrumental problems. However, no single systematic effect seems sufficient. Because consistent path length determinations were carried out both before and after the HCl measurements in question, a sudden change in instrument performance must be ruled out. Gas pressure and dilution effects cannot cause the type of wavenumber-dependent effects observed in the CTS spectra; subsequent laboratory measurements of  $C_2H_4$  indicated that temperature variations, like pressure and dilution effects, would lead to path length errors in the same direction for the CH and FP regions. Because the same EPA CTS ethylene spectra were used in all the path length determinations and led to excellent statistical results in all cases, potential data processing errors in the deresolution procedure are also insufficient to explain

the anomalous results. However, we note that the observed 18% discrepancy still allows high confidence in the data and the infrared technique, and the discrepancy is obvious mainly because of the overall high quality of the data set and statistical results.

## Conclusions

The evaluation presented in this paper demonstrates that the EPA FTIR Protocol analytical procedures based on the use of laboratory reference spectra to determine analyte concentrations in sample spectra give excellent, and verifiable, results. This is true even for HCl, which is difficult to sample, and even when the reference spectra are deresolved to match the sample spectra.

Two independent analyses using different programs and different spectral input data were performed on 6 FTIR data sets collected at a site with HCl emissions. The alternate analyses produced nearly identical results in 4 of the data sets. In two of the data sets the agreement was also good, but the average discrepancy of about 18 percent between results produced by the alternate analyses was larger than the average measurement uncertainty of about 5.5 percent. A preliminary evaluation of this discrepancy has not determined the exact cause, but it is probably attributable to an anomaly in the measurement of the absorption path length for the one test run.

These results also demonstrate the need for careful instrument performance checks and preparation of library reference spectra. Strict QA/QC standard procedures are required to produce accurate measurements. The Method 301 validation results showed no significant bias in the FTIR measurements of HCl at this test, but the validation procedure cannot reveal a constant offset "error" that is applied equally to both spiked and unspiked samples.

## Acknowledgments

The field test discussed in this paper was funded by the Emission Measurement Center of the United States Environmental Protection Agency.

## References

- 1) Draft Method 320, "Measurement of Vapor Phase Organic and Inorganic Emissions by Extractive Fourier Transform Infrared (FTIR) Spectroscopy," EPA Contract No. 68-D2-0165, Work Assignment 3-08, July, 1996.
- 2) "Protocol For The Use of FTIR Spectrometry to Perform Extractive Emissions Testing at Industrial Sources," EPA Contract No. 68-D2-0165, Work Assignment 3-12, EMTIC Bulletin Board, September, 1996.
- 3) "Method 301 - Field Validation of Pollutant Measurement Methods from Various Waste Media," 40 CFR Part 63, Appendix A.

4. D.M. Haaland and R.G. Easterling, "Improved Sensitivity of Infrared Spectroscopy by the Application of Least Squares Methods," Appl. Spectrosc. 34(5):539-548 (1980).
5. D.M. Haaland and R.G. Easterling, "Application of New Least-Squares Methods for the Quantitative Infrared Analysis of Multicomponent Samples," Appl. Spectrosc. 36(6):665-673 (1982).
6. D.M. Haaland, R.G. Easterling and D.A. Vopicka, "Multivariate Least-Squares Methods Applied to the Quantitative Spectral Analysis of Multicomponent Samples," Appl. Spectrosc. 39(1):73-84 (1985).
7. W.C. Hamilton, Statistics in Physical Science, Ronald Press Co., New York, 1964, Chapter 4.
8. P.R. Griffiths and J.A. DeHaseh, Fourier Transform Infrared Spectroscopy, John Wiley and Sons, New York, 1986, ISBN 0-471-09902-3.
9. G. M. Plummer and W. K. Reagen, "An Examination of a Least Squares Fit FTIR Spectral Analysis Method," Air and Waste Management Association, Paper Number 96-WA65.03, Nashville, 1996.
10. T. J. Geyer, "Method 301 Validation of Fourier Transform Infrared (FTIR) spectroscopy For Measuring Formaldehyde and Carbonyl Sulfide," Air and Waste Management Association, Paper Number. 96-RA110.03, Nashville, 1996.

**Table 1.** Pathlength Determination Results.

	CTS Conditions		CH region		FP region	
	# Passes	Temp (K)	Result (m)	% uncert.	Result (m)	% uncert.
	16	293	6.5	2.9	6.7	1.3
Run 3 (Figure 3)	20	293	11.0	2.6	11.3	1.6
	20	393	10.2	2.5	14.3	2.2
Run2 (Figure 2)	40	293	19.2	5.5	20.0	1.8
	40	393	20.2	2.6	23.4	1.6

**Table 2.** Fractional Calibration Uncertainties (FCU in Reference 2) For the Two Quantitative Analyses.

Compound	FCU (%)	Analytical Region (cm <sup>-1</sup> )
HCl "4fit"	4.6	2747 - 2848
HCl "Mcomp"		2569 - 2871
Run 2 *	1.05	
Run 3 *	3.14	

\* Spectra of four samples from the cylinder standard (103 ppm HCl in nitrogen) were used in the "Mcomp" analysis. The spectra were measured at the same instrument configuration used in each run.

**Table 3.** Summary of results comparisons in 4 runs (8 data sets).

Data Set	Average "4FIT" Results		Average "Multicomp" Result		No. of Results <sup>3</sup>
	HCl ppm	% 4 * $\sigma$ <sup>1</sup>	HCl ppm	% Difference <sup>2</sup>	
Run 1 Inlet	43.3	3.9	42.1	2.9	36
Run 1 Outlet	34.5	4.1	32.9	4.4	30
Run 2 Inlet	14.8	7.7	13.1	11.8 <sup>4</sup>	16
Run 2 Outlet (Figure 2)	48.0	4.5	46.4	3.2	33
Run 3 Inlet	62.5	5.6	50.9	18.6	41
Run 3 Outlet (Figure 3)	58.0	5.5	47.3	18.4	52

1 - Average percent uncertainty in the 4FIT results.

2 - Equals (4FIT-Multicomp)/4FIT.

3 - Equals the number of spectra included in the average. Results from condenser and ambient air samples were not included in the averages.

4 - Flow restriction during this run may have caused HCl losses resulting in lower measured concentrations for this run. An average difference of 1.7 ppm corresponded to a relatively large percent difference of 11.8 % on the smaller average concentration for this run.

**Table 4.** Method 301 statistical analysis of "4FIT" HCl results in Figure 3.

	Unspiked			Spiked		
	HCl ppm	$d_i$	$(d_i)^2$	HCl ppm	$d_i$	$(d_i)^2$
Run Average =	57.18 *	9.68	52.561	62.14 *	4.74	25.784
Statistical Results	SD =	2.093		SD =	1.466	
	F =	0.491		SD <sub>pooled</sub> =	1.807	
	RSD=	3.7		Exp Conc =	5.05	
	Bias =	-0.088		CF =	1.02	
	t =	0.12				

\* Represents the average result in 12 unspiked or spiked samples. Statistical variables are described in Section 6.3 of EPA Method 301.<sup>3</sup> Procedure for determining spiked dilution factor and expected concentration, Exp Conc, is described in reference 10.

**Table 5.** Summary of Method 301 statistical analysis of "Multicomp" results in Figure 3.

	Unspiked			Spiked		
	HCl ppm	$d_i$	$(d_i)^2$	HCl ppm	$d_i$	$(d_i)^2$
Run Average =	45.88 *	8.62	34.242	50.86 *	3.51	21.496
Statistical Results	SD =	1.689		SD =	1.338	
	F =	0.628		SD <sub>pooled</sub> =	1.524	
	RSD=	3.7		Exp Conc =	5.05	
	Bias =	-0.070		CF =	1.01	
	t =	0.11				

\* Represents the average result in 12 unspiked or spiked samples. Statistical variables are described in Section 6.3 of EPA Method 301.<sup>3</sup> Procedure for determining spiked dilution factor and expected concentration, Exp Conc, is described in reference 10.

Figure 1. Extractive sampling system.

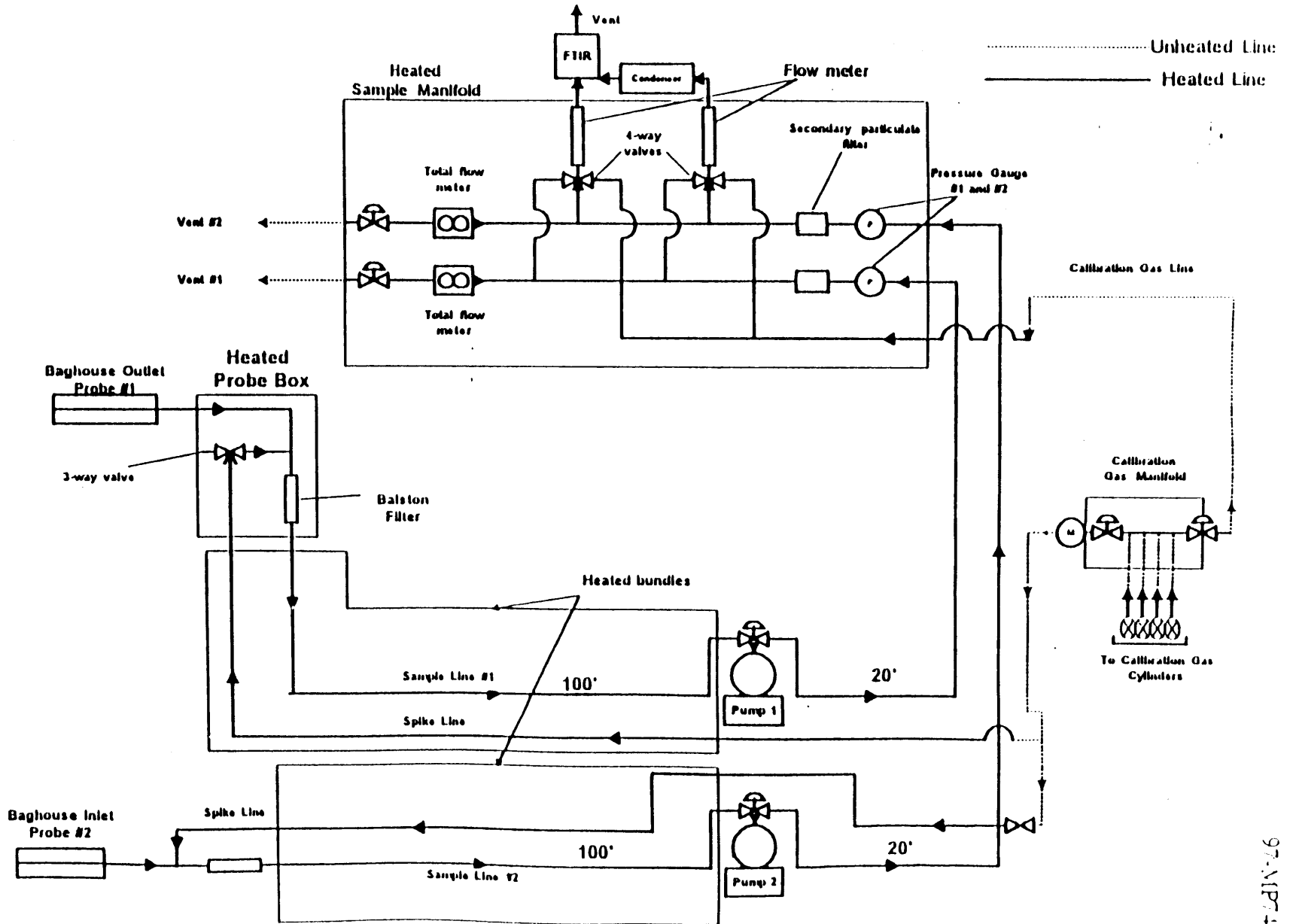

D-120

APPENDIX E

PROCESS DATA

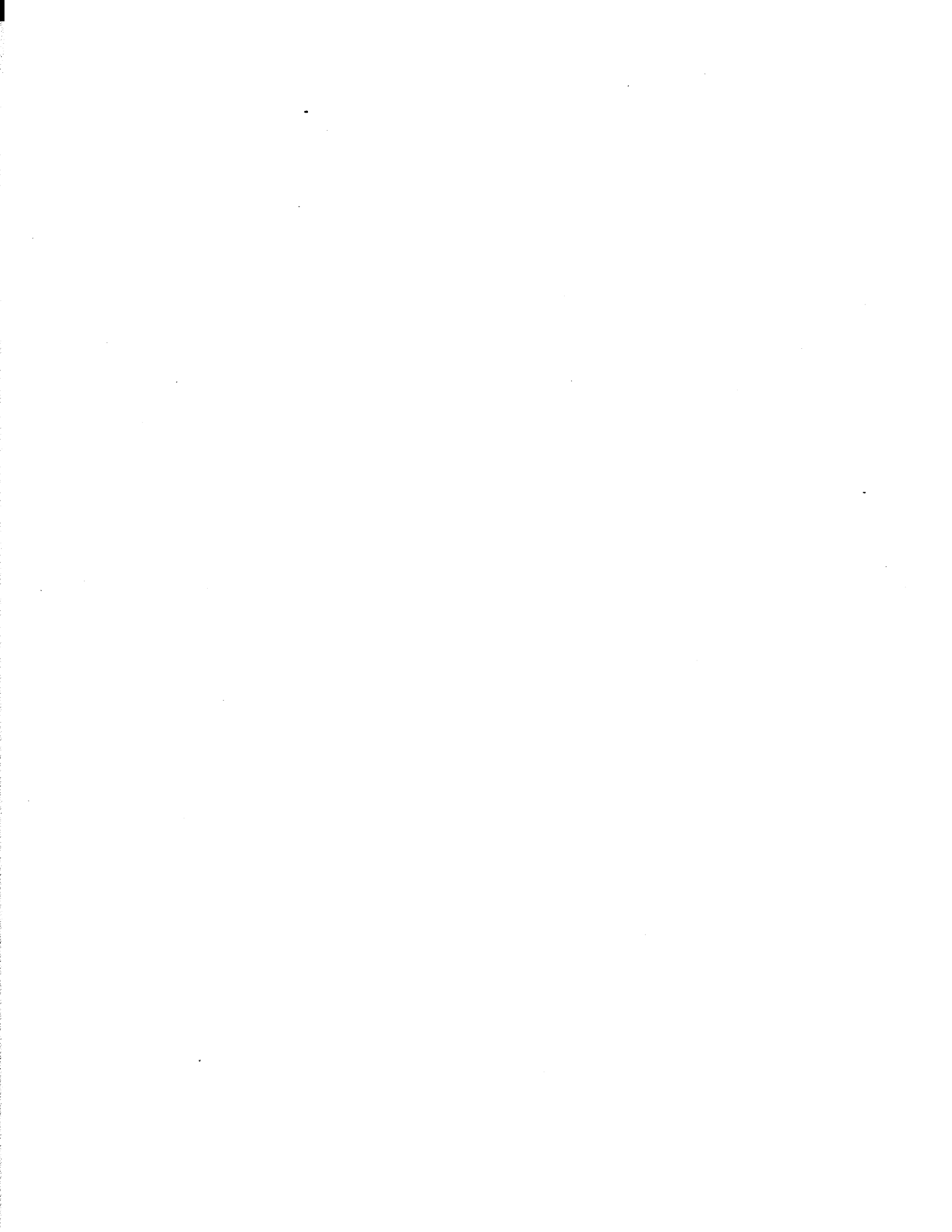



This process description was prepared by ECR Incorporated and was provided to MRI by the Emission Measurement Center. The process description was included in this report without review by MRI.



PROCESS DESCRIPTION FOR CARY (WEST RALEIGH) FACILITY

Facility Description

The Construction Asphalt Concrete Production Facility in Cary, North Carolina, has been in operation since 1987. It is a parallel flow, continuous drum mix process. The dryer/mixer is an ASTEC drum (8 ft. by 45 ft.), with a rated capacity of 325 tons per hour. The plant has the capability of producing up to 14 asphalt mix types, with or without the use of reclaimed asphalt pavement (RAP).

Asphalt concrete, called "hot mix asphalt" (HMA) by the industry, is a mixture of well-graded, high quality virgin aggregate that is heated and mixed with liquid asphalt cement to produce paving material. The characteristics of the asphalt concrete are determined by the relative amounts and types of aggregate (and RAP) used. In the asphalt reclamation process, old asphalt pavement is removed from the road surface, transported to the plant, and crushed and screened to the appropriate size for further processing.

In the parallel flow continuous drum mix process, virgin aggregate of various sizes is fed to the dryer/mixer by cold feed controls in proportions dictated by the final mix specifications. Aggregate is delivered by conveyor belt to the dryer section of the drum, entering at the same end as the burner (hence, the descriptor "parallel" flow). The aggregate is heated and dried by the high temperatures in the dryer and then moves into the mixer section where it is coated with liquid asphalt cement, and conditioner (if used). Liquid asphalt cement and conditioner are delivered to the mixer by a variable flow pump that is electronically linked to the aggregate feed weigh scales. The hot aggregate mixture is also combined with RAP (if any) and recycled dust from the control system. The resulting asphalt concrete mixture is discharged from the end of the drum mixer and conveyed to storage silos for delivery to trucks.

There are six cold storage bins and three hot mix storage silos at the Cary facility. The hot mix storage silo capacity is 200 tons each, for a total of 600 tons. There are two screens for aggregate sizing and two 25,000 gallon heated asphalt cement storage vessels, for a total asphalt cement capacity of 50,000 gallons (125 tons). The plant usually uses natural gas for all its process fuel needs; however, during the source tests No.2 oil, the back-up fuel, was used in the drum mixer. The amount of energy needed from the fuel for the asphalt production process is 300,000 BTU per ton of asphalt produced. The hot gas contact time, i.e. the time from when the aggregate enters the dryer to when it exits the coater, is between,

approximately, 3 to 4 minutes. Surface mixes are closer to 3 minutes and Base mixes are closer to 4 minutes.

The Cary facility uses an asphalt cement (AC) called AC-20, obtained from Citgo of Wilmington, North Carolina. An anti-strip conditioner, called Ad-Here (from Arr-Maz), is sometimes used; antistrip is required for all NC DOT jobs.

For particulate matter (PM) control, the facility uses a knockout box as a primary control and a fabric filter as a secondary control. The fabric filter is an ASTEC Pulse-Jet, equipped with 780 14-ounce Nomex bags; it is operated with an air-to-cloth ratio of approximately 5 feet per minute. The process gas exits the drum and proceeds through the knockout box into a fabric filter, where it is exhausted through a stack. As mentioned above, the dust collected by the PM control devices is recycled to process.

### Source Tests

EPA source tests were performed at Cary facility on August 27, 28, and 29, 1997. The source testing took place at the inlet and outlet of the fabric filter. Process data were taken at 15-minute intervals during the entire "test period," i.e. during the time period when at least one manual and both instrumental tests were running. According to plant personnel, the plant was operating under normal conditions during the tests.

For the three test dates (August 27, 28, and 29, 1997), the average asphalt concrete production rates per test run were 201, 199, and 163 tons per hour (tph), respectively, corresponding to total production of 1,039, 1,242, and 839 tons. During the first two test runs (August 27 and 28), a surface asphalt coating that included RAP was produced; during the third test run (August 29), a surface coating (accounting for 73% of the total asphalt concrete produced) and a binder coating (accounting for 27% of total production) were produced, both without RAP. A high sulfur No.2 fuel oil was used for fuel in the production process during the tests. No conditioner was used during the tests. No visible emissions were observed by EC/R Inc. personnel during the source tests.

Table 1 that follows summarizes the operating conditions observed during the EPA source test periods at Cary facility. Tables 2 and 3 describe the asphalt mixes produced and the fuel used, respectively, during the tests. Table 4 describes the specifics of plant operation during the tests. Appendix A shows all the data recorded during the tests, along with the results of statistical analyses.

TABLE 1. PLANT OPERATING CONDITIONS DURING SOURCE TESTS,  
AUGUST 27, 28, AND 29, 1997

Process Data	Test Run / Test Date		
	Run 1 08/27/97	Run 2 08/28/97	Run 3 08/29/97
Product Type(s) <sup>a</sup>	surface mix, with RAP (BCSC RI-2)	surface mix, with RAP (BCSC RI-2)	surface mix, no RAP (BCSC I-2); and binder (BCBC, Type H)
Asphalt Concrete Production Rate, tph Average <sup>b</sup> Range Total Produced, tons	201 149-212 1,039	199 192-206 1,241	163 130-195 839
Mix Temperature, °F Average <sup>b</sup> Range	301 290-330	299 284-321	303 286-352
Raw Material (Virgin Aggregate) Use Rate, tph Average <sup>b</sup> Range Total Used, tons	153 113-161 788	151 145-154 943	154 122-183 839
RAP Use rate, tph Average <sup>b</sup> Range Total Used, tons	36 18-40 197	36 30-43 235	none
Asphalt Cement Use rate, tons/hr Average <sup>b</sup> Range Total Used, tons	12.3 9.1-12.9 54	12.1 11.7-12.6 64	9.2 6.8-12.1 51
Conditioner	none	none	none

(Continued)

TABLE 1. (continued)

Process Data	Test Run / Test Date		
	Run 1 08/27/97	Run 2 08/28/97	Run 3 08/29/97
<b>Fabric Filter Operation<sup>b</sup></b>			
Temperature, °F			
Inlet	344	343	325
Outlet	271	283	269
Pressure Drop, inches water			
Average <sup>b</sup>	0.9	0.9	1.2
Range	0.8-1.2	0.1-1.1	0.5-2.0
<b>Fuel</b>			
Use Rate, ° gph			
Total Used, gal	340 1,906	344 2,305	266 1,620
<b>Visible Emissions</b>	none	none	none

- a BCSC, Type I-2 = bituminous concrete, surface coarse  
 BCSC, Type RI-2 = bituminous concrete, surface coarse, with RAP  
 BCBC, Type H = bituminous concrete, binder coarse (type H)

See Table 2 for more detail on product specifications.

- <sup>b</sup> As a straight average of the 15-minute interval data shown in Appendix A.
- <sup>c</sup> Fuel use rate was calculated from the total fuel used during the time interval.

**TABLE 2. ASPHALT MIX SPECIFICATIONS**

<b>Product</b>	<b>Material</b>	<b>Amount</b>
Surface Coating (BCSC, Type I-2)	78-M regular screenings classified screenings asphalt cement	22% aggregate 34% aggregate 44% aggregate 6.4% mix
Surface Coating, with RAP (BCSC, Type RI-2)	78-M screenings classified screenings RAP asphalt cement total additional from RAP	17% aggregate 23% aggregate 42% aggregate 18% aggregate 6.4% mix 5.2% mix 0.9% mix
Binder (BCBC, Type H)	78-M #67 regular screenings wet screenings asphalt cement	19% aggregate 48% aggregate 23% aggregate 10% aggregate 4.6% mix

**TABLE 3. FUEL SPECIFICATIONS**

<b>Fuel Type</b>	<b>Characteristic(s)</b>	<b>Descriptor(s)</b>
High Sulfur No.2 Fuel Oil	flash point 125°F sulfur <500 mg/kg (0.05%) API index 33.2	dyed diesel fuel not for on-road use

TABLE 4. SPECIFICS OF PLANT OPERATION DURING EPA SOURCE TESTS AT

Parameter	Test Run / Test Date		
	Run 1 08/27/97	Run 2 08/28/97	Run 3 08/29/97
Test Period	0940-1516	0746-1428	0809-1413
Plant Shut Downs* (with approximate duration)	1002 (5 min) 1140 (6 min) 1402 (10 min)	0901 (8 min) 1110 (18 min) 1355 (12 min)	1212 (9 min) 1242 (41 min)
Plant Production Rate Change(s)	1430-1515: mix rate slowed down from nominally 200 to 150 tph	none	1007-1222: mix rate increased from nominally 150 to 200 tph  1237-1422: mix rate decreased from nominally 200 to 130 tph
Product Changes	none	none	0807-0822 and 1022-1422: I-2 produced (642 tons)  0837-1007: binder produced (237 tons)

\* The shutdown at 1242 during Run 3 was put into effect to avoid overfilling of the silos with asphalt concrete mix; all other shutdowns were due to aggregate clogging in the conveyor system.



Appendix A: Process Data

Cary

Test Run 1

Test Date: August 27, 1997

Total Test Time: 5.6 hrs

Time	Event	Product Type	Asphalt Concrete Production		Asphalt Temp. (oF)	Aggregate Use		RAP Use		Asphalt Cement Use		Calculated Conditioner Use	
			Rate (TPH)	Total (tons)		Rate (TPH)	Total (tons)	Rate (TPH)	Total (tons)	Rate (TPH)	Total (tons)	Rate (TPH)	Total (tons)
0940		RI-2	210	547	297	159	418	39	102	12.9	28	0	0
1000	*	RI-2	209	600	297	159	457	37	112	12.7	31	0	0
1015		RI-2	208	631	309	159	481	37	118	12.6	32	0	0
1030		RI-2	209	684	303	158	521	38	128	12.8	35	0	0
1045		RI-2	210	736	296	159	560	38	138	12.7	38	0	0
1100		RI-2	209	788	310	158	600	39	147	12.6	40	0	0
1115		RI-2	208	840	301	158	640	38	157	12.7	43	0	0
1130	*	RI-2	209	892	301	158	679	39	167	12.7	46	0	0
1145		RI-2	208	928	320	158	707	37	174	12.7	48	0	0
1200		RI-2	211	976	304	159	743	40	183	12.9	50	0	0
1215		RI-2	209	1,028	301	159	782	37	193	12.8	53	0	0
1230		RI-2	210	1,080	296	159	822	38	203	12.8	55	0	0
1245		RI-2	211	1,133	292	159	862	39	213	12.9	58	0	0
1300		RI-2	212	1,185	330	160	902	39	223	12.9	61	0	0
1315		RI-2	209	1,238	292	160	942	37	233	12.7	64	0	0
1330		RI-2	207	1,290	305	159	981	36	243	12.5	66	0	0
1345	*	RI-2	211	1,343	293	161	1,022	37	253	12.9	69	0	0
1415		RI-2	206	1,422	290	158	1,081	35	268	12.8	73	0	0
1430		RI-2	211	1,474	297	161	1,120	37	278	12.9	76	0	0
1445	*	RI-2	149	1,511	296	113	1,149	18	285	9.2	78	0	0
1500		RI-2	151	1,549	292	114	1,177	28	292	9.2	80	0	0
1516		RI-2	149	1,586	308	113	1,206	26	299	9.1	82	0	0

Appendix A: Process Data

Cary

Test Run 1

Test Date: August 27, 1997

Total Test Time: 5.6 hrs

Time	Event	Product Type	Asphalt Concrete Production		Asphalt Temp. (oF)	Aggregate Use		RAP Use		Asphalt Cement Use		Calculated Conditioner Use	
			Rate (TPH)	Total (tons)		Rate (TPH)	Total (tons)	Rate (TPH)	Total (tons)	Rate (TPH)	Total (tons)	Rate (TPH)	Total (tons)
Total				1,039		788		197		54			0
Mean			201		301	153		36		12.3		0	
St. Dev			21		9	16		5		1.2		0	
Min			149		290	113		18		9.1		0	
Max			212		330	161		40		12.9		0	

\*See Table 4 for a description of these events.

Appendix A: Process Data

Cary

Test Run 1

Test Date: August 27, 1997

Total Test Time: 5.6 hrs

Time	Event	Product Type	Fabric Filter			Fuel Use (gal)	Visible Emissions
			Inlet Temp. (oF)	Outlet Temp. (oF)	Pressure Drop (in. H2O)		
0940		RI-2	345	270	0.8	77564	none
1000	*	RI-2	340	270	0.8	77656	none
1015		RI-2	365	270	0.8	77719	none
1030		RI-2	350	285	0.9	77815	none
1045		RI-2	340	270	0.9	77911	none
1100		RI-2	350	270	0.9	78003	none
1115		RI-2	350	270	0.9	78113	none
1130	*	RI-2	350	280	0.9	78201	none
1145		RI-2	330	235	1.2	78260	none
1200		RI-2	350	275	1.1	78375	none
1215		RI-2	340	280	1.0	78448	none
1230		RI-2	340	270	1.0	78577	none
1245		RI-2	340	270	1.0	78648	none
1300		RI-2	335	270	1.0	78749	none
1315		RI-2	335	270	1.0	78837	none
1330		RI-2	350	270	0.8	78923	none
1345		RI-2	340	270	0.8	79020	none
1415		RI-2	350	260	0.9	79154	none
1430		RI-2	330	280	1.0	79258	none
1445	*	RI-2	350	270	1.0	79325	none
1500		RI-2	345	275	1.0	79404	none
1516		RI-2	350	285	1.0	79470	none

Appendix A: Process Data

Cary

Test Run 1

Test Date: August 27, 1997

Total Test Time: 5.6 hrs

Time	Event	Product Type	Fabric Filter			Fuel Use (gal)	Visible Emissions
			Inlet Temp. (oF)	Outlet Temp. (oF)	Pressure Drop (in. H2O)		
Total						1,906	
Mean			344	271	0.9		
St. Dev			8	10	0.1		
Min			330	235	0.8		
Max			365	285	1.2		

\*See Table 4 for a description of these events.

Appendix A: Process Data

Cary

Test Run 2

Test Date: August 28, 1997

Total Test Time: 6.7 hrs

Time	Event	Product Type	Asphalt Concrete Production		Asphalt Temp. (oF)	Aggregate Use		RAP Use		Asphalt Cement Use		Calculated Conditioner Use	
			Rate (TPH)	Total (tons)		Rate (TPH)	Total (tons)	Rate (TPH)	Total (tons)	Rate (TPH)	Total (tons)	Rate (TPH)	Total (tons)
0746		RI-2	194	86	295	146	66	37	15	11.7	4	0	0
0800		RI-2	193	116	298	145	90	36	21	11.8	6	0	0
0815		RI-2	192	164	294	147	126	34	30	11.7	8	0	0
0830		RI-2	195	212	288	148	163	36	39	11.7	11	0	0
0845		RI-2	197	261	299	149	200	36	48	12.0	13	0	0
0900	*	RI-2	195	310	306	149	237	34	57	12.0	16	0	0
0915		RI-2	198	341	300	150	260	36	63	12.1	17	0	0
0930		RI-2	206	390	285	150	298	43	73	12.6	20	0	0
0945		RI-2	200	440	299	151	336	37	82	12.2	22	0	0
1000		RI-2	199	490	299	151	372	36	92	12.1	25	0	0
1015		RI-2	198	540	299	151	411	35	101	12.2	27	0	0
1030		RI-2	199	589	302	151	449	36	110	12.1	30	0	0
1045		RI-2	198	639	301	151	487	35	120	12.2	33	0	0
1100	*	RI-2	204	689	297	153	525	39	129	12.3	35	0	0
1130		RI-2	199	755	296	152	575	35	142	12.2	38	0	0
1145		RI-2	203	805	321	153	613	38	152	12.2	41	0	0
1200		RI-2	201	856	307	154	651	35	161	12.2	44	0	0
1215		RI-2	201	906	309	152	689	37	171	12.2	46	0	0
1230		RI-2	203	957	304	154	728	37	180	12.3	49	0	0
1245		RI-2	198	1007	303	153	766	32	190	12.1	51	0	0
1300		RI-2	204	1058	284	154	805	38	200	12.3	54	0	0
1315		RI-2	203	1109	296	154	843	37	209	12.3	56	0	0
1330		RI-2	202	1159	305	153	881	36	219	12.2	59	0	0
1345	*	RI-2	195	1209	302	152	920	30	228	12.0	62	0	0
1415		RI-2	197	1278	293	150	972	35	241	12.0	65	0	0
1428		RI-2	198	1327	302	150	1009	36	250	12.0	68	0	0

Appendix A: Process Data

Cary

Test Run 2

Test Date: August 28, 1997

Total Test Time: 6.7 hrs

Time	Event	Product Type	Asphalt Concrete Production		Asphalt Temp. (oF)	Aggregate Use		RAP Use		Asphalt Cement Use		Calculated Conditioner Use	
			Rate (TPH)	Total (tons)		Rate (TPH)	Total (tons)	Rate (TPH)	Total (tons)	Rate (TPH)	Total (tons)	Rate (TPH)	Total (tons)
Total				1,241		943		235		64			0
Mean			199		299	151		36		12.1		0	
St. Dev			4		7	2		2		0.2		0	
Min			192		284	145		30		11.7		0	
Max			206		321	154		43		12.6		0	

\*See Table 4 for a description of these events.

Appendix A: Process Data

Cary

Test Run 2

Test Date: August 28, 1997

Total Test Time: 6.7 hrs

Time	Event	Product Type	Fabric Filter			Fuel Use (gal)	Visible Emissions
			Inlet Temp. (oF)	Outlet Temp. (oF)	Pressure Drop (in. H2O)		
0746		RI-2	345	340	0.9	79777	none
0800		RI-2	340	260	0.8	79861	none
0815		RI-2	340	270	0.9	79947	none
0830		RI-2	330	255	0.9	80048	none
0845		RI-2	340	260	0.8	80118	none
0900	*	RI-2	350	270	0.9	80224	none
0915		RI-2	350	280	1.0	80284	none
0930		RI-2	330	285	1.0	80374	none
0945		RI-2	340	285	1.0	80485	none
1000		RI-2	350	280	1.0	80570	none
1015		RI-2	350	290	1.0	80655	none
1030		RI-2	350	285	1.0	80763	none
1045		RI-2	345	280	1.0	80854	none
1100	*	RI-2	350	290	1.0	80943	none
1130		RI-2	350	280	1.1	81068	none
1145		RI-2	360	300	1.0	81170	none
1200		RI-2	350	295	1.0	81261	none
1215		RI-2	350	290	1.0	81364	none
1230		RI-2	350	295	1.0	81461	none
1245		RI-2	340	285	1.0	81529	none
1300		RI-2	325	275	1.0	81611	none
1315		RI-2	335	275	0.5	81692	none
1330		RI-2	335	285	0.5	81776	none
1345	*	RI-2	340	290	0.5	81864	none
1415		RI-2	330	280	0.1	81978	none
1428		RI-2	340	275	0.9	82082	none

Appendix A: Process Data

Cary

Test Run 2

Test Date: August 28, 1997

Total Test Time: 6.7 hrs

Time	Event	Product Type	Fabric Filter			Fuel Use (gal)	Visible Emissions
			Inlet Temp. (oF)	Outlet Temp. (oF)	Pressure Drop (in. H2O)		
Total						2,305	
Mean			343	283	0.9		
St. Dev			8	16	0.2		
Min			325	255	0.1		
Max			360	340	1.1		

\*See Table 4 for a description of these events.



Appendix A: Process Data

Cary

Test Run 3

Test Date: August 29, 1997

Total Test Time: 6.1 hrs

Time	Event	Product Type	Asphalt Concrete Production		Asphalt Temp. (oF)	Aggregate Use		RAP Use		Asphalt Cement Use		Calculated Conditioner Use	
			Rate (TPH)	Total (tons)		Rate (TPH)	Total (tons)	Rate (TPH)	Total (tons)	Rate (TPH)	Total (tons)	Rate (TPH)	Total (tons)
0809		I-2	130	28	344	122	28	0	0	8.1	1	0	0
0822		I-2	160	66	293	150	66	0	0	9.9	4	0	0
0837		Binder	150	102	310	143	102	0	0	6.8	6	0	0
0852		Binder	153	139	296	146	138	0	0	7.1	8	0	0
0907		Binder	154	175	296	147	175	0	0	7.0	9	0	0
0922		Binder	154	212	295	147	212	0	0	7.0	11	0	0
0937		Binder	155	249	296	148	249	0	0	7.2	13	0	0
0952		Binder	155	285	300	148	285	0	0	7.2	15	0	0
1007	*	Binder	188	329	297	179	329	0	0	8.7	17	0	0
1022		I-2	185	373	300	177	373	0	0	8.4	19	0	0
1037		I-2	194	419	291	182	419	0	0	12.0	22	0	0
1052		I-2	193	464	300	181	464	0	0	12.0	25	0	0
1107		I-2	195	509	302	183	509	0	0	12.1	28	0	0
1122		I-2	194	555	286	182	555	0	0	12.0	31	0	0
1137		I-2	194	600	288	182	600	0	0	12.0	34	0	0
1152		I-2	193	645	289	181	645	0	0	12.0	37	0	0
1207	*	I-2	194	691	297	182	691	0	0	12.0	40	0	0
1222		I-2	193	709	302	182	709	0	0	11.8	41	0	0
1237	*	I-2	132	749	334	124	749	0	0	8.2	44	0	0
1325		I-2	130	772	352	122	772	0	0	8.0	45	0	0
1337		I-2	130	788	293	122	788	0	0	8.0	46	0	0
1352		I-2	130	818	292	122	818	0	0	8.1	48	0	0
1407		I-2	131	819	307	123	849	0	0	8.1	50	0	0
1413		I-2	130	867	311	123	867	0	0	8.1	52	0	0

Appendix A: Process Data

Cary

Test Run 3

Test Date: August 29, 1997

Total Test Time: 6.1 hrs

Time	Event	Product Type	Asphalt Concrete Production		Asphalt Temp. (oF)	Aggregate Use		RAP Use		Asphalt Cement Use		Calculated Conditioner Use	
			Rate (TPH)	Total (tons)		Rate (TPH)	Total (tons)	Rate (TPH)	Total (tons)	Rate (TPH)	Total (tons)	Rate (TPH)	Total (tons)
Total				839			839		0		51		0
Mean			163		303	154		0		9.2		0	
St. Dev			26		17	25		0		2.0		0	
Min			130		286	122		0		6.8		0	
Max			195		352	183		0		12.1		0	

\*See Table 4 for a description of these events.

Appendix A: Process Data

Cary

Test Run 3

Test Date: August 29, 1997

Total Test Time: 6.1 hrs

Time	Event	Product Type	Fabric Filter			Fuel Use (gal)	Visible Emissions
			Inlet Temp. (oF)	Outlet Temp. (oF)	Pressure Drop (in. H2O)		
0809		I-2	365	285	1.0	83174	none
0822		I-2	320	265	2.0	83250	none
0837		Binder	335	285	1.0	83317	none
0852		Binder	320	270	1.2	83394	none
0907		Binder	320	270	1.2	83444	none
0922		Binder	320	270	1.1	83508	none
0937		Binder	325	270	1.1	83572	none
0952		Binder	330	270	1.1	83638	none
1007	*	Binder	320	270	1.0	83711	none
1022		I-2	290	270	1.0	83784	none
1037		I-2	310	260	1.2	83872	none
1052		I-2	320	260	1.5	83927	none
1107		I-2	320	270	1.3	84055	none
1122		I-2	310	260	1.2	84171	none
1137		I-2	310	260	1.2	84209	none
1152		I-2	310	260	1.2	84305	none
1207	*	I-2	320	265	1.5	84404	none
1222		I-2	310	250	1.9	84434	none
1237	*	I-2	360	290	1.9	84512	none
1325		I-2	370	270	0.5	84556	none
1337		I-2	320	260	0.5	84600	none
1352		I-2	320	260	0.5	84657	none
1407		I-2	335	280	1.0	84728	none
1413		I-2	335	280	1.0	84794	

E-19

Appendix A: Process Data

Cary

Test Run 3

Test Date: August 29, 1997

Total Test Time: 6.1 hrs

Time	Event	Product Type	Fabric Filter			Fuel Use (gal)	Visible Emissions
			Inlet Temp. (oF)	Outlet Temp. (oF)	Pressure Drop (in. H2O)		
Total						1,620	
Mean			325	269	1.2		
St. Dev			18	9	0.4		
Min			290	250	0.5		
Max			370	290	2.0		

\*See Table 4 for a description of these events.