

# BACKGROUND DOCUMENT

## REPORT ON REVISIONS TO 5<sup>TH</sup> EDITION AP-42 CHAPTER 15 - ORDNANCE DETONATION

EMISSION FACTORS DEVELOPED BASED ON FIRING POINT EMISSION STUDY PHASE II  
SERIES 10 TESTING CONDUCTED AT ABERDEEN PROVING GROUND, MARYLAND

**DRAFT**

Prepared for:  
U.S. Army Environmental Command  
ATTN: IMAE-ATT  
Aberdeen Proving Ground, Maryland 21010-5401

February 2008



## **NOTICE**

The information in this document has been funded by the U.S. Army Environmental Command (USAEC) and prepared by MACTEC Federal Programs, Inc., under Contract No. GS-10F-0157K, Order No. W911SR-05-F-0023. It has been reviewed by the U.S. Environmental Protection Agency (EPA) Office of Air Quality Planning and Standards (OAQPS) and has been approved for publication. Mention of trade names or commercial products does not constitute endorsement or recommendation for use.

DRAFT

# TABLE OF CONTENTS

	<u>Page</u>
<b>1.0 INTRODUCTION.....</b>	<b>1</b>
<b>2.0 COMPOUNDS MEASURED AND EMISSION MEASUREMENT METHODS.....</b>	<b>2</b>
2.1 Carbon Monoxide, Carbon Dioxide, Oxides of Nitrogen, and Sulfur Dioxide .....	3
2.2 Sulfur Hexafluoride, Ammonia, Carbon Monoxide, Carbon Dioxide, and Methane.....	5
2.3 Total Suspended Particulate .....	6
2.4 Particulate Matter with an Aerodynamic Diameter Less than or Equal to 10 or 2.5 Microns ..	6
2.5 Metals .....	6
2.6 Volatile Organic Compounds .....	6
2.7 Semivolatile Organic Compounds and Polycyclic Aromatic Hydrocarbons .....	7
2.8 Dioxin and Furan Compounds .....	7
2.9 Acid Gases.....	7
2.10 Hydrogen Cyanide.....	7
2.11 Aldehydes and Carbonyl Compounds .....	8
2.12 Hydrocarbons, n-Hexane, and Sulfur Hexafluoride .....	8
2.13 Energetic Materials.....	8
2.14 Total Carbon.....	8
2.15 Hexavalent Chromium .....	9
2.16 Perchlorate.....	9
<b>3.0 TEST DATA ANALYSIS AND RATINGS .....</b>	<b>9</b>
3.1 EPA Guidance Regarding Test Data Quality Ratings .....	9
3.2 Analysis of Test Data .....	10
3.3 Test Data Quality Ratings .....	16
<b>4.0 EMISSION FACTOR CALCULATIONS.....</b>	<b>17</b>
4.1 Correction of Sample Volume to Standard Conditions .....	18
4.2 Incorporation of Analytical Detection Limits to the Test Data .....	19
4.3 Determination of Background Concentration .....	19
4.4 Determination of Test Compound Concentration .....	20
4.5 Determination of Background-Corrected Concentration .....	20
4.6 Determination of Dilution-Corrected Concentration.....	22
4.7 Determination of Mass of Compound Released.....	22
4.8 Determination of Emission Factors .....	22
4.9 Determination of Average Emission Factors .....	22
4.10 Determination of Total Emission Factors for DODIC B627.....	22
<b>5.0 EMISSION FACTOR RATINGS.....</b>	<b>23</b>
5.1 Emission Factor Ratings Assigned – Based on Ordnance-Specific Test Data .....	23
5.2 Emission Factor Ratings Assigned – Based on All Available Test Data .....	24
<b>6.0 REFERENCES.....</b>	<b>33</b>

**TABLE OF CONTENTS (cont.)**

- APPENDIX A: COMPOUNDS ANALYZED AND EMISSION FACTORS DEVELOPED FOR ORDNANCE INCLUDED IN FIRING POINT EMISSION STUDY PHASE II SERIES 10 TESTING AT ABERDEEN PROVING GROUND, MARYLAND
- APPENDIX B: NEW AP-42 SECTIONS FOR ORDNANCE INCLUDED IN FIRING POINT EMISSION STUDY PHASE II SERIES 10 TESTING AT ABERDEEN PROVING GROUND, MARYLAND

**LIST OF TABLES**

<b><u>No.</u></b>	<b><u>Title</u></b>	<b><u>Page</u></b>
1	Ordnance for Which Emission Factors Were Developed .....	1
2	Ordnance Net Explosive Weight.....	2
3	Sampling and Analytical Methods Used.....	4
4	Selected Analytical Method for Compounds Analyzed Using Two Analytical Methods.....	12
5	Compounds for Which Large Relative Percent Differences Were Noted Between Test Runs.....	14
6	Compounds Found in the Method Blank at Levels Between 20 Percent and 50 Percent of Both Test Values .....	15
7	Compounds Found in the Method Blank at Levels Greater Than 50 Percent of Both Test Values.....	15
8	Downgraded Data Quality Ratings .....	16
9	Ordnance Categorization for Emission Factor Correlation Assessment.....	25

**LIST OF FIGURES**

<b><u>No.</u></b>	<b><u>Title</u></b>	<b><u>Page</u></b>
1	Calculation of background-corrected concentration .....	21

## 1.0 INTRODUCTION

Due to the lack of credible data concerning emissions from training ordnance when used in their tactical configurations, the U.S. Army Environmental Command (USAEC) established a program to quantify emissions from the detonation of ordnance. This document presents background information concerning the development of air emission factors for seven types of ordnance used during training exercises at U.S. Army installations. The air emission factors were developed from test data collected by USAEC. Ordnance for which emission factors have been developed and their corresponding AP-42 sections are identified in Table 1. To help readers easily find those emission factors of interest, the ordnance are organized according to their Department of Defense Identification Code (DODIC).

TABLE 1 ORDNANCE FOR WHICH EMISSION FACTORS WERE DEVELOPED

DODIC	Ordnance Description	AP-42 Section
A017	12 Gage #9 Shot Cartridge	15.1.3
A518	M962 .50 Caliber Saboted Light Armor Penetrator-Tracer Cartridge	15.1.26
B627	M83A3 60-mm Illuminating Mortar Cartridge (propelling charge only)	15.2.8
B645	M766 60-mm Short Range Practice Mortar Cartridge (propelling charge only)	15.2.11

It should be noted that the air emission factors documented herein are only representative of emissions associated with the use of the propelling cartridge. Emissions associated with the impact and/or detonation of the propelled projectile are addressed elsewhere.

The emission factors described in this document are based on data obtained during testing conducted at Aberdeen Proving Ground, Maryland, as presented in the final test report titled *Report No. 10 for the Firing Point Emission Study, Phase II*<sup>1</sup> and the document titled *Detailed Test Plan No. 10 for the Firing Point Emission Study, Phase II*.<sup>2</sup> These documents were supplemented by additional data provided by the testing contractor.<sup>3</sup> For each ordnance, two test runs (or trials) were conducted. In order to generate measurable quantities of emissions, between one and five rounds were fired per test run, depending upon the ordnance. Source test protocols were developed by USAEC before any testing was conducted and were reviewed by the U.S. Environmental Protection Agency's (EPA's) Emission Measurement Center. The tests were conducted between July 14 and July 28, 2004.

The compounds that were measured included carbon monoxide (CO), carbon dioxide (CO<sub>2</sub>), oxides of nitrogen (NO<sub>x</sub>), sulfur dioxide (SO<sub>2</sub>), ammonia (NH<sub>3</sub>), methane (CH<sub>4</sub>), total suspended particulate (TSP), particulate matter with an aerodynamic diameter less than or equal to 10 microns (PM-10), particulate matter with an aerodynamic diameter less than or equal to 2.5 microns (PM-2.5), metals, volatile organic compounds (VOC), semivolatile organic compounds (SVOC), dioxin and furan compounds, acid gases, hydrogen cyanide (HCN), aldehyde and carbonyl compounds, hydrocarbons, polycyclic aromatic hydrocarbons (PAH), energetic materials, total carbon, hexavalent chromium, and perchlorate. Within each of the AP-42 sections, only emission factors for criteria pollutants, carbon dioxide, methane, hazardous air pollutants (as defined by §112(b)(1) of the *Clean Air Act* [CAA]), and toxic chemicals (as defined by §313 of the *Emergency Planning and Community Right-to-Know Act* [EPCRA]) are presented.

The emission factors were developed on a “per item” basis and on a “per net explosive weight (NEW)” basis. Users should choose the appropriate emission factor to estimate emissions based upon the data available; either factor is equally valid. The NEW of each ordnance tested is provided in the corresponding AP-42 section and in Table 2.

TABLE 2 ORDNANCE NET EXPLOSIVE WEIGHT

DODIC	Ordnance Description	NEW (lb/item) <sup>a</sup>
A017	12 Gage #9 Shot Cartridge	2.70 E-03
A518	M962 .50 Caliber Saboted Light Armor Penetrator-Tracer Cartridge	4.11 E-02
B627	M83A3 60-mm Illuminating Mortar Cartridge (propelling charge only)	2.21 E-02 <sup>b</sup>
B645	M766 60-mm Short Range Practice Mortar Cartridge (propelling charge only)	6.56 E-03

<sup>a</sup> NEW values were obtained from References 1 and 3.

<sup>b</sup> Fired with two propellant charge increments. Each increment has an NEW of 3.66 grams.

This document includes five sections in addition to this Introduction. Section 2 of this document identifies the compounds measured during the test program and describes the emission measurement methods used. Section 3 includes a discussion of the emission factor final test report and ratings for the test data contained therein. Section 4 describes the calculations and methodologies used to develop emission factors for each type of compound measured. Section 5 describes the methodology used to rate the emission factors and provides emission factor ratings for each type of compound measured. Section 6 includes a complete list of the references cited in this document.

There are two appendices included with this document. Appendix A identifies, by ordnance type, all of the compounds for which analyses were performed and the emission factors that were developed. [Note: Compounds present in the method blank at greater than 50 percent of test levels are excluded from Appendix A as described in Section 3.2.4]. Appendix A also identifies the minimum detection levels associated with all compounds that were not detected. Emission factors and minimum detection levels presented in Appendix A were determined from the most accurate method if two sampling or analytical methods were used to measure one compound. Appendix B presents the new AP-42 sections for the four ordnance that were tested.

In addition to this document, there are electronic databases available on the web (<http://www.epa.gov/ttn/chief/ap42/index.html>) that contain the data used in the development of the emission factors. The general procedures that were followed to develop these emission factors can be found at the same web address under the titles *Procedures for Preparing Emission Factor Documents*<sup>4</sup> and *Draft Detailed Procedures for Preparing Emission Factors*.<sup>5</sup>

## 2.0 COMPOUNDS MEASURED AND EMISSION MEASUREMENT METHODS

The USAEC Firing Point Series 10 testing was conducted in the Emission Characterization Chamber (ECC) located at the Aberdeen Test Center (ATC), Maryland. The ECC is a 3/8-inch thick steel cylinder with parabolic caps welded to each end. The chamber is approximately 7 feet in diameter and 15 feet long with a high-solids epoxy coating on all interior and exterior surfaces. A personnel access door and remotely operated firing port door are integrated into the rear and front parabolic caps,

respectively. The firing port door allows the projectile to exit the chamber and then closes to maintain the seal required for emissions characterization.

Fans inside the ECC ensure even distribution of the sulfur hexafluoride (SF<sub>6</sub>) tracer gas and weapon emission products. A series of 12 ports are located along the sides and top of the chamber to accommodate instrumentation. A separate instrumentation and test control building is part of the facility and instrumentation and firing of the weapon can be controlled remotely from this location. Instrumentation and equipment are in place to collect emission product data.

A removable interior partition, located between the second and third instrumentation ports, allows the test volume of the facility to be adjusted to approximately 213, 307, or 520 cubic feet, depending on the size of the weapon tested and expected quantity of emissions. Additional flexibility in testing is provided by weapon boxes that can be mounted to the partition. The weapon boxes are of varying sizes to accommodate different weapons, and are equipped with sealed gloves and viewing ports to allow weapons to be manually operated when needed. The boxes also allow testing to occur when the desired test volume is too small to physically accommodate a weapon.

A number of different test methods were employed to collect and analyze the emission data that were used to develop emission factors for firing of ordnance. Table 3 identifies each emission test method used; bracketed information identifies the purpose of using the method. The emissions data were collected using EPA test methods published in Title 40 of the Code of Federal Regulations, Part 50 (40 CFR 50); 40 CFR 60; 40 CFR 63; and in *Compendium of Methods for the Determination of Toxic Organic Compounds in Ambient Air*.<sup>6</sup> Some of the sample analytical procedures used were from EPA Office of Solid Waste (OSW) publication SW-846, *Test Methods for Evaluating Solid Waste, Physical/Chemical Methods*<sup>7</sup> and the *National Institute for Occupational Safety and Health (NIOSH) Manual of Analytical Methods (NMAM), Fourth Edition*.<sup>8</sup> Additional sampling and analytical procedures were taken from Internal Operating Procedures (IOP) developed by the ATC Chemistry Team and from Standard Operating Procedures (SOP) developed by the U.S. Army Center for Health Promotion and Preventive Medicine (USACHPPM) Directorate of Laboratory Sciences (DLS). Where necessary, the test methods were adapted to reflect application to the unique testing of ordnance firing in the ECC.

The following sections identify and briefly describe the test methods used to measure each compound or group of compounds. Additional information regarding the operation of the ECC and the test methods used is presented in Reference 2. EPA-approved methods were used by the laboratories that provided sampling and analysis data.

## **2.1 Carbon Monoxide, Carbon Dioxide, Oxides of Nitrogen, and Sulfur Dioxide**

Real-time concentrations of CO, CO<sub>2</sub>, NO<sub>x</sub>, and SO<sub>2</sub> that resulted from the use of ordnance in the ECC were measured using a continuous emissions measurement system (CEMS). The final test report<sup>1</sup> states that the compounds were measured using EPA reference methods as described in the following paragraph. Although the report does include results for some quality control checks, due to a lack of calibration data, conformance with the stated methodologies could not be confirmed.

CO sampling and analysis was conducted in accordance with 40 CFR Part 60, Appendix A, Method 10 - *Determination of Carbon Monoxide Emissions from Stationary Sources*, with a Thermo Environmental Instruments, Inc. (TEI) Model No. 41C nondispersive infrared analyzer. CO<sub>2</sub> sampling and analysis was conducted in accordance with 40 CFR Part 60, Appendix A, Method 3A - *Determination of Oxygen and Carbon Dioxide Concentrations in Emissions from Stationary Sources*, with a TEI Model No. 48C nondispersive infrared analyzer. NO<sub>x</sub> sampling and analysis was conducted in accordance with 40 CFR Part 60, Appendix A, Method 7E - *Determination of Nitrogen Oxides Emissions*

TABLE 3 SAMPLING AND ANALYTICAL METHODS USED

Compound	Test Method
CO	40 CFR 60, Appendix A, EPA Method 10 - <i>Determination of Carbon Monoxide Emissions from Stationary Sources</i> [sampling and analysis]
CO <sub>2</sub>	40 CFR 60, Appendix A, EPA Method 3A - <i>Determination of Oxygen and Carbon Dioxide Concentrations in Emissions from Stationary Sources (Instrumental Analyzer Procedure)</i> [sampling and analysis]
NO <sub>x</sub>	40 CFR 60, Appendix A, EPA Method 7E - <i>Determination of Nitrogen Oxides Emissions from Stationary Sources (Instrumental Analyzer Procedure)</i> [sampling and analysis]
SO <sub>2</sub>	40 CFR 60, Appendix A, EPA Method 6C - <i>Determination of Sulfur Dioxide Emissions from Stationary Sources (Instrumental Analyzer Procedure)</i> [sampling and analysis]
SF <sub>6</sub> , NH <sub>3</sub> , CO, CO <sub>2</sub> , and CH <sub>4</sub>	40 CFR 63, Appendix A, EPA Proposed Method 320 - <i>Measurement of Vapor Phase Organic and Inorganic Emissions by Extractive Fourier Transform Infrared (FTIR) Spectroscopy</i> [sampling and analysis]
TSP	40 CFR 60, Appendix A, EPA Method 17- <i>Determination of Particulate Emissions from Stationary Sources (In-Stack Filtration Method)</i> [sampling] 40 CFR 50, Appendix B - <i>Reference Method for the Determination of Suspended Particulate Matter as in the Atmosphere (High Volume Method)</i> [analysis]
PM-10 and PM-2.5	40 CFR 60, Appendix A, modified EPA Method 17 – <i>Determination of Particulate Emissions from Stationary Sources (In-Stack Filtration Method)</i> [sampling] 40 CFR 50, Appendix B - <i>Reference Method for the Determination of Suspended Particulate Matter as in the Atmosphere (High Volume Method)</i> [analysis]
Metals	Metal sample was obtained from TSP sample [sampling] 40 CFR 50, Appendix G Modified - <i>Reference Method for Determination of Lead in Suspended Particulate Matter Collected from Ambient Air</i> [analysis]
VOC	EPA Compendium Method TO-14A - <i>Determination of Volatile Organic Compounds (VOCs) in Ambient Air Using Specially Prepared Canisters with Subsequent Analysis by Gas Chromatography</i> [sampling and analysis]
SVOC	EPA Compendium Method TO-13A - <i>Determination of Polycyclic Aromatic Hydrocarbons (PAHs) in Ambient Air Using Gas Chromatography/Mass Spectrometry (GC/MS)</i> [sampling and analysis] SW-846 Method 8270 Modified (SW8270M) - <i>Semivolatile Organic Compounds by Gas Chromatography/Mass Spectrometry (GC/MS)</i> [analysis]
PAH	EPA Compendium Method TO-13A - <i>Determination of Polycyclic Aromatic Hydrocarbons (PAHs) in Ambient Air Using Gas Chromatography/Mass Spectrometry (GC/MS)</i> [sampling and analysis]
Dioxins and Furans	EPA Compendium Method TO-9A - <i>Determination of Polychlorinated, Polybrominated, and Brominated/Chlorinated Dibenzo-p-Dioxins and Dibenzofurans in Ambient Air</i> [sampling and analysis]
Acid Gases	NIOSH Method 7903 - <i>Inorganic Acids</i> [sampling and analysis]



TABLE 3 (cont.)

Compound	Test Method
Hydrogen Cyanide	NIOSH Method 7904 - <i>Aerosol and Gas Cyanides</i> [sampling and analysis]
Aldehydes and Carbonyls	EPA Compendium Method TO-11A - <i>Determination of Formaldehyde in Ambient Air Using Adsorbent Cartridge Followed by High Performance Liquid Chromatography (HPLC)</i> [sampling] ATC IOP No. 389.4 - [analysis]
Hydrocarbons and n-Hexane	40 CFR 60, Appendix A, EPA Method 18 - <i>Measurement of Gaseous Organic Compound Emissions by Gas Chromatography</i> [sampling] USACHPPM SOP CAD 64.1 - <i>Procedure for the Identification and Measurement of C1 Through C6 Hydrocarbons and Sulfur Hexafluoride in Tedlar Gas Bags</i> [analysis]
SF <sub>6</sub>	40 CFR 60, Appendix A, EPA Method 18 - <i>Measurement of Gaseous Organic Compound Emissions by Gas Chromatography</i> [sampling] Project specific IOP, IR and gas chromatography with electron capture detection (GC/ECD) [analysis]
Energetic Materials	EPA Compendium Method TO-13A - <i>Determination of Polycyclic Aromatic Hydrocarbons (PAHs) in Ambient Air Using Gas Chromatography/Mass Spectrometry (GC/MS)</i> [sampling] USACHPPM SOP CAD 26.3 – <i>Procedure for Analysis of Explosives in Ambient Air</i> and USACHPPM SOP CAD 69.3 – <i>Procedure for Analysis of Propellant Components in Ambient Air</i> [analysis]
Total Carbon	NIOSH Method 5040 - <i>Diesel Particulate Matter as Elemental Carbon</i> [sampling and analysis]
Hexavalent Chromium	OSHA Method ID-215 - <i>Hexavalent Chromium in Workplace Atmospheres</i> [sampling and analysis]
Perchlorate	EPA Method 314 - <i>Determination of Perchlorate in Drinking Water Using Ion Chromatography</i> [sampling and analysis]

from Stationary Sources, with a TEI Model No. 42C-HL chemiluminescent analyzer. SO<sub>2</sub> sampling and analysis was conducted in accordance with 40 CFR Part 60, Appendix A, Method 6C - *Determination of Sulfur Dioxide Emissions from Stationary Sources*, with a TEI Model No. 43H pulsed fluorescent analyzer.

Each analyzer channel sampled at approximately 11.5 liters per minute (L/min) through Teflon tubing with Mine Safety Appliance (MSA) ultra type H cartridge filters used to control particulate. An inline Balston® 95S6 filter was used to trap condensation. Although the testing was conducted at ambient conditions, heated probes and sample lines were used to control condensation. Data were collected four times per second.

## 2.2 Sulfur Hexafluoride, Ammonia, Carbon Monoxide, Carbon Dioxide, and Methane

Extractive FTIR spectroscopy was used to measure real-time concentrations of the SF<sub>6</sub> tracer gas, NH<sub>3</sub>, CO, CO<sub>2</sub>, and CH<sub>4</sub>, as well as to qualitatively identify other permanent gas species using protocols

modified from procedures published in 40 CFR 63, Appendix A, EPA Proposed Method 320 - *Measurement of Vapor Phase Organic and Inorganic Emissions by Extractive Fourier Transform Infrared (FTIR) Spectroscopy*. Samples were drawn continuously from the ECC at a nominal rate of 14 L/min using Teflon tubing and an Alcatel Pascal<sup>®</sup> rotary vane-type pump, for a minimum of 21 minutes. The FTIR spectra were collected and stored at least every 20 seconds.

### **2.3 Total Suspended Particulate**

The TSP concentration that resulted from the use of ordnance in the ECC was determined using a modified sampling and analysis procedure based on 40 CFR 60, Appendix A, Reference Method 17 – *Determination of Particulate Emissions from Stationary Sources (In-Stack Filtration Method)*. An Air Metrics TSP ambient air sampling module equipped with a quartz fiber filter was connected by a flex line to the Method 17 metering system. The metering system extracted test chamber air through a particulate filter at a nominal rate of 11 L/min for a target minimum sampling time of 20 minutes. The TSP concentration was computed, in accordance with 40 CFR 50, Appendix B – *Reference Method for the Determination of Suspended Particulate Matter as in the Atmosphere*, by dividing the mass of TSP collected by the volume of air sampled, corrected to standard conditions.

### **2.4 Particulate Matter with an Aerodynamic Diameter Less than or Equal to 10 or 2.5 Microns**

The PM-10 and PM-2.5 concentrations that resulted from the use of ordnance in the ECC were determined using a modified sampling and analysis procedure based on 40 CFR 60, Appendix A, modified EPA Method 17 – *Determination of Particulate Emissions from Stationary Sources (In-Stack Filtration Method)*. An ambient sampler with Air Metrics PM-10 and PM-2.5 ambient air sampling modules was used to collect the PM-10 and PM-2.5 samples at a sampling rate of 5 L/min each (i.e., a total sampling rate of 10 L/min) for 20 minutes. The PM-10 and PM-2.5 modules were equipped with polytetrafluorethylene (PTFE) particulate filters that were weighed before and after sampling in accordance with 40 CFR 50, Appendix B – *Reference Method for the Determination of Suspended Particulate Matter as in the Atmosphere*. The particulate concentrations were computed by dividing the mass of PM-10 and PM-2.5 collected by the respective volume of air sampled, corrected to standard conditions.

### **2.5 Metals**

Metal concentrations that resulted from the use of ordnance in the ECC were determined using particulate matter from the TSP samples collected as described in Section 2.3. The analyses followed the procedures of 40 CFR 50, Appendix G - *Reference Method for the Determination of Lead in Suspended Particulate Matter Collected from Ambient Air*. The method was modified to use an inductively coupled plasma atomic emission spectrophotometer (ICP-AES) for analysis and to include additional metals. Concentrations of target metals were computed by dividing the mass of metal collected by the volume of air sampled, corrected to standard conditions.

### **2.6 Volatile Organic Compounds**

VOC concentrations that resulted from the use of ordnance in the ECC were determined using procedures from the *Second Supplement to Compendium of Methods for the Determination of Toxic Organic Compounds in Ambient Air*, Method TO-14A - *Determination of Volatile Organic Compounds (VOCs) in Ambient Air Using Specially-Prepared Canisters with Subsequent Analysis by Gas Chromatography*. Air samples were collected at a sampling rate of 0.6 L/min for 20 minutes using a XonTech, Inc., pressurized canister sampler and silicon-lined SUMMA canister that was certified VOC-free prior to use. An analysis by gas chromatography/mass spectrometry in full scan mode

(GC/MS/SCAN) followed. Unknown compounds were tentatively identified using computerized mass spectral matching techniques.

## 2.7 Semivolatile Organic Compounds and Polycyclic Aromatic Hydrocarbons

SVOC and PAH concentrations that resulted from the use of ordnance in the ECC were determined based on procedures found in Method TO-13A - *Determination of Polycyclic Aromatic Hydrocarbons (PAHs) in Ambient Air Using Gas Chromatography/Mass Spectrometry (GC/MS)*. During each run, samples were collected using a TISCH® TE-1002 ambient air sampling module equipped with a quartz fiber filter and XAD-2 adsorbent resin cartridge. The sampling module was connected by flex line to a stack source airflow metering system. The metering system extracted the sample at a nominal rate of 28 L/min for 20 minutes. Following sampling, the filters and resin cartridges underwent solvent extraction and analysis by GC/MS analysis in selected ion monitoring (SIM) mode. The sample extracts were reanalyzed in scan mode following modified procedures in SW-846 Method 8270 - *Semivolatile Organic Compounds by Gas Chromatography/Mass Spectrometry (GC/MS)*. Modifications are described in the USACHPPM SOPs SV54.1 - *The Determination of Gaseous and Particulate Polynuclear Aromatic Hydrocarbons in Ambient Air Using Gas Chromatography/Mass Spectrometry in the Selective Ion Monitoring Mode (GS/MS-SIM)*, EPA TO-13 and SV72.7 - *Analysis of SW-846 Extracts for Semivolatile Organics by EPA Method 8270C*. Unknown compounds were tentatively identified using computerized mass spectral matching techniques.

## 2.8 Dioxin and Furan Compounds

Polychlorinated dibenzodioxin (PCDD) and polychlorinated dibenzofuran (PCDF) compound concentrations that resulted from the use of ordnance in the ECC were determined based on procedures found in Method TO-9A - *Determination of Polychlorinated, Polybrominated and Brominated/Chlorinated Dibenzo-p-Dioxins and Dibenzofurans in Ambient Air*. Samples were collected using a TISCH TE-1002 ambient air sampling module with a quartz fiber particulate filter and a polyurethane foam (PUF) packed cartridge. The sampling module was connected to a stack source airflow metering system with a flex line and used to sample for 20 minutes at a nominal rate of 28 L/min. After sampling, the filters and cartridges underwent extraction and analysis by GC/High Resolution Mass Spectroscopy according to Method TO-9A.

## 2.9 Acid Gases

Acid gas concentrations that resulted from the use of ordnance in the ECC were determined based on procedures found in NIOSH Method 7903 - *Inorganic Acids*. Acid gases were collected by using silica gel sorbent tubes (ORBO-53) and a sampling pump using an APEX Instruments Model No. 623 meter console. Sample gases were passed through the sorbent tubes for 20 minutes at a nominal rate of 0.5 L/min. Analysis was performed according to NIOSH Method 7903, by ion chromatography as detailed in ATC IOP No. 372 - *Anion Analysis Using the AS14 Column*.

## 2.10 Hydrogen Cyanide

HCN concentrations that resulted from the use of ordnance in the ECC were determined using NIOSH Method 7904 - *Aerosol and Gas Cyanides*, but using modified sampling and analytical procedures. The sample gas was drawn through a 1-micrometer Teflon filter and an impinger containing 0.1 normal potassium hydroxide (KOH) for 20 minutes at a nominal rate of 1.0 L/min. The impinger solution and extracted filter were analyzed by ion chromatography in accordance with NIOSH Method 7904 and ATC IOP No. 231 - *Analysis of Cyanide and Sulfide by Ion Chromatography*.

## 2.11 Aldehydes and Carbonyl Compounds

Aldehyde and carbonyl compound concentrations that resulted from the use of ordnance in the ECC were determined using EPA Compendium Method TO-11A - *Determination of Formaldehyde in Ambient Air Using Adsorbent Cartridge Followed by High Performance Liquid Chromatography (HPLC)*, but using modified sampling and analytical procedures. Dinitrophenylhydrazine (DNPH) laden cartridge tubes were used as a direct probe to trap and derivatize aldehyde and carbonyl compounds. Sample gases were extracted for 20 minutes (nominal) from the test chamber through ozone denuders at a rate of 2.0 L/min using an Apex Instruments Model No. 623 meter console. Analysis was by reverse-phase HPLC with ultraviolet (UV) detection using Compendium Method TO-11A modified as detailed in ATC IOP No. 389.4 - *Analysis of Formaldehyde and Other Carbonyl Compounds by High Performance Liquid Chromatography*.

## 2.12 Hydrocarbons, n-Hexane, and Sulfur Hexafluoride

Hydrocarbon, n-hexane, and SF<sub>6</sub> concentrations that resulted from the use of ordnance in the ECC were sampled using 40 CFR 60, Appendix A, EPA Method 18 - *Measurement of Gaseous Organic Compound Emissions by Gas Chromatography*. The samples were collected in Tedlar<sup>®</sup> bags at a nominal rate of 0.4 L/min for 20 minutes. Analysis for the light hydrocarbons was by gas chromatography with a flame ionization detector (GC/FID) in accordance with USACHPPM SOP CAD 64.1 - *Procedure for the Identification and Measurement of C1 Through C6 Hydrocarbons and Sulfur Hexafluoride in Tedlar Gas Bags*. SF<sub>6</sub> was analyzed by gas chromatography with electron capture detection (GC/ECD). This measurement served as a backup to the FTIR measurement of SF<sub>6</sub>.

## 2.13 Energetic Materials

Energetic compound concentrations that resulted from the use of ordnance in the ECC were determined based on procedures found in EPA Compendium Method TO-13A - *Determination of Polycyclic Aromatic Hydrocarbons (PAHs) in Ambient Air Using Gas Chromatography/Mass Spectrometry (GC/MS)*. Samples were collected using a TISCH TE-1002 ambient air sampling module equipped with a quartz fiber particulate filter and an XAD-2 adsorbent resin cartridge. The sampling module was used to sample for 20 minutes at a rate of approximately 28 L/min.

Analyses followed procedures outlined in USACHPPM SOP CAD 26.3 - *Procedure for Analysis of Explosives in Ambient Air* and USACHPPM SOP CAD 69.3 - *Procedure for Analysis of Propellant Components in Ambient Air*. These operating procedures specifically address the extraction and analysis of XAD-2 resin used to sample energetic and propellant compounds from air. The compounds were extracted from the XAD-2 resin using isoamyl acetate and analyzed by gas chromatography with electron capture detection (GC/ECD) or gas chromatography with mass spectrometry (GC/MS). A surrogate compound (3,4-dinitrotoluene) was added to the XAD-2 resin prior to sampling. The quartz fiber filter used in conjunction with the XAD-2 resin was extracted and analyzed separately to characterize the energetic materials present as particulate solids. The filter was placed in a vial containing isoamyl acetate immediately after testing to preserve the sample and prevent sublimation of any of the analytes. No surrogate compound was used in the analysis of the filter portion of the sample.

## 2.14 Total Carbon

Total carbon concentrations that resulted from the use of ordnance in the ECC were determined based on the procedures in NIOSH Method 5040 - *Diesel Particulate Matter as Elemental Carbon*. Samples were collected at a rate of 2.0 L/min using an APEX Instruments Model No. 623 meter console. A dry gas meter contained in the console was used to measure the sample volume. Flow rates were

verified using an electronic flow meter. The particulate sample was collected on a 37-mm heat-treated quartz fiber filter and was analyzed using a thermo-optical analyzer to differentiate between organic and elemental carbon.

### **2.15 Hexavalent Chromium**

The hexavalent chromium concentrations that resulted from the use of ordnance in the ECC were determined based on modified procedures in OSHA Method ID-215 - *Hexavalent Chromium in Workplace Atmospheres*. Since particulate results from previous weapons firing showed that a large fraction of the total particulate produced was less than 2.5 microns in size, the method was modified to use a 0.8- $\mu\text{m}$  pore size polyvinyl chloride (PVC) filter instead of a 5- $\mu\text{m}$  PVC filter. Samples were collected at a rate of 3.5 L/min using an APEX Instruments Model No. 623 meter console. A dry gas meter contained in the console was used to measure the sample volume. Flow rates were verified using an electronic flow meter. The filter media was extracted and analyzed using ion chromatography with post-column derivatization and detection with a UV-Vis detector.

### **2.16 Perchlorate**

Perchlorate concentrations that resulted from the use of ordnance in the ECC were determined based on the procedures in ATC IOP No. 412 – *Analysis of Perchlorate Ion by Ion Chromatography with the AS-16 Column* and EPA Method 314 - *Determination of Perchlorate in Drinking Water Using Ion Chromatography*. Particulate perchlorate sampling was performed using a 50-mm Teflon open-face filter cassette with 2-micron pore size Teflon filters. A Teflon impinger containing deionized water was used to trap perchloric acid vapor. Samples were drawn at a rate of 1.5 L/min via an APEX Instruments Model No. 623 meter console. A dry gas meter contained in the console was used to measure the sample volume. Flow rates were verified using an electronic flow meter. The filter media was extracted using deionized water and both the filter extract and the impinger solution were analyzed using ion chromatography with conductivity detection.

## **3.0 TEST DATA ANALYSIS AND RATINGS**

### **3.1 EPA Guidance Regarding Test Data Quality Ratings**

Prior to inclusion of emission factors in AP-42, the reliability of the underlying emission test data must be appraised in accordance with the rating system specified in Reference 4. Under this rating system, test data are assigned a rating from A to D, where an “A” rating is assigned to the highest quality data. The criteria used to assign a specific data quality rating are summarized below.

- A** Tests are performed by using an EPA reference test method, or when not applicable, a sound methodology. Tests are reported in enough detail for adequate validation and raw data are provided that can be used to duplicate the emission results presented in the report.
- B** Tests are performed by a generally sound methodology, but lacking enough detail for adequate validation. Data are insufficient to completely duplicate the emission result presented in the report.
- C** Tests are based on an unproven or new methodology, or are lacking a significant amount of background information.
- D** Tests are based on a generally unacceptable method, but the method may provide an order-of-magnitude value for the source.

Four specific criteria are identified in Reference 4 for consideration to assist in the assignment of a test data quality rating. These four criteria are:

1. Source operation. If the manner in which the source was operated is well documented in the report and the source was operating within typical parameters during the test, an “A” rating should be assigned. If the report stated parameters that were typical, but lacked detailed information, a “B” rating should be assigned. If there is reason to believe the operation was not typical, a “C” or “D” rating should be assigned.
2. Test methods and sampling procedures. In developing the ratings, the estimated accuracy and precision of the test method as well as the adequacy of the documentation should be considered. In general, if a current EPA reference test method, appropriate for the source, was followed, the rating should be higher (“A” or “B”). If other methods were used, an assessment should be made of their validity. If it is judged that the method was likely to be inaccurate or biased, a lower rating (“C” or “D”) should be given. A complete report should indicate whether any procedures deviated from standard methods and explain any deviations. If deviations were reported, an evaluation should be made of whether these were likely to influence the test results.
3. Process information. During testing, many variations in the process can occur without warning and sometimes without being noticed. Such variations can induce wide deviations in sampling results. If a large variation between test run results cannot be explained by information contained in the site final test report or from test reports of other sources, the data are suspect and should be given a lower rating or excluded. However, it should be recognized that a process may have highly variable emissions and a lower rating may not be appropriate solely on the basis of wide deviations in sampling results.
4. Analysis and calculations. Ideally, final test reports should contain original raw data sheets and other documentation such as gas parameters (dry cubic feet per minute, oxygen percentage), calculation sheets, or example calculations describing how the calculated emission results were obtained. If there are data sheets, the nomenclature and equations used should be compared to those specified by EPA to establish equivalency. The depth of review of the calculations should be dictated by the reviewers’ confidence in the ability and conscientiousness of the tester, based on such factors as consistency of results and completeness of other areas of the final test report. Reports may indicate that raw data sheets were available, but were not included. If the final test report is of high quality based on the other criteria, the quality rating should not be lowered due to a lack of data sheets.

An overall test data quality rating should be assigned based upon the ratings assigned for each of the four criteria.

### **3.2 Analysis of Test Data**

Data included in the final test report,<sup>1</sup> the detailed test plan,<sup>2</sup> and in the analytical data supporting the test report<sup>3</sup> were rated in accordance with the rating system described above. Results for each of the four criteria described above are presented in the following sections.

#### **3.2.1 Source Operations**

The manner in which the ordnance were deployed (i.e., used) is documented in the final test report. Each ordnance that was tested was deployed in a manner similar to that which would occur in the field. The tests appear to have replicated typical ordnance operating parameters; consequently, the test data should be assigned an “A” rating based on this criterion.

### 3.2.2 Test Methods and Sampling Procedures

The test methods and sampling procedures were evaluated as being appropriate and consistent with EPA test methods or sound methodology. Except as noted below, no problems of any significance were identified; consequently, the test data should be assigned an “A” rating based on this criterion.

#### 3.2.2.1 CEMS-Measured Data

CEMS data were provided for the tests,<sup>3</sup> but not for the pre- and post-test quality control (QC) activities. CEMS QC measures specified under 40 CFR 60, Appendix A, EPA Methods 3A, 7E, and 6C were not followed. Furthermore, none of the calibration gas certifications were supplied. There was no evidence of bias in the data, but based on the issues noted above, the test data for the CEMS-measured compounds (i.e., CO, CO<sub>2</sub>, NO<sub>x</sub>, and SO<sub>2</sub>) should be assigned a “B” rating based on this criterion.

#### 3.2.2.2 Compounds Sampled or Analyzed Using More than One Test Method or Analytical Method

Thirty-six compounds were either sampled or analyzed using two methods; these compounds are identified in Table 4. For each of these compounds, emission factors were calculated based upon the data measured using the more appropriate test or analytical method; data obtained using the less appropriate method were ignored. The more appropriate method was identified by reviewing the methods and the target compound lists associated with each method. If a specific compound appeared on the target compound list for one method but not the other, the method targeting the compound was selected. If a specific compound appeared on the target compound lists for both methods, the method judged to provide the most accurate data was selected.

If a compound was analyzed using both the SW8270M (SVOC) and TO-14A (VOC) methods, the TO-14A method analysis was judged to be more accurate and was therefore selected. For compounds analyzed using both the SW8270M (SVOC) and TO-13A (PAH) methods, the TO-13A value was selected because TO-13A allowed quantification of compounds at lower levels than SW8270M. For compounds sampled using FTIR spectroscopy and a CEMS, the CEMS measurements were judged to be more accurate. For compounds analyzed using both SW8270M (SVOC) and SOP CAD 26.3(energetic materials), the SOP CAD 26.3 data were selected because SOP CAD 26.3 allows detection of compounds at lower levels than SW8270M. If a compound was analyzed using both the TO-14A (VOC) and TO-11A (aldehydes) methods, the TO-11A method analysis was judged to be more accurate and was therefore selected. For compounds analyzed using both TO-14A (VOC) and Method 18 (hydrocarbons), and for which the compounds appeared on both target compound lists, the Method 18 analysis was judged to be more accurate and was selected. For compounds analyzed using both FTIR spectroscopy and Method 18 (hydrocarbons), the Method 18 analysis was judged to be more accurate and was selected.

Occasionally, the compound measurement from the less accurate method was chosen because the compound was present in the method blank of the preferred method. In addition, if a compound sampled under two methods had poor precision between test runs for the sampling method that would have been more accurate under normal circumstances, data from the other method were used to calculate emission factors. These cases are also noted in the footnotes to Table 4.

TABLE 4 SELECTED ANALYTICAL METHOD FOR COMPOUNDS ANALYZED USING TWO ANALYTICAL METHODS

Compound	Selected Method	Other Method Employed
Carbon dioxide	40 CFR 60, Method 3A (CEMS)	40 CFR 63, Method 320 (FTIR)
Carbon monoxide	40 CFR 60, Method 10 (CEMS)	40 CFR 63, Method 320 (FTIR)
Methane	40 CFR 60, Method 18 (Hydrocarbons)	40 CFR 63, Method 320 (FTIR)
Acenaphthene <sup>a,b</sup>	TO-13A (PAH)	SW8270M (SVOC)
Acenaphthylene	TO-13A (PAH)	SW8270M (SVOC)
Acrolein	TO-11A (Aldehydes)	TO-14A (VOC)
Anthracene <sup>c</sup>	TO-13A (PAH)	SW8270M (SVOC)
Benzo[a]anthracene	TO-13A (PAH)	SW8270M (SVOC)
Benzo[b]fluoranthene	TO-13A (PAH)	SW8270M (SVOC)
Benzo[k]fluoranthene	TO-13A (PAH)	SW8270M (SVOC)
Benzo[g,h,i]perylene	TO-13A (PAH)	SW8270M (SVOC)
Benzo[a]pyrene <sup>d</sup>	TO-13A (PAH)	SW8270M (SVOC)
1,3-Butadiene	40 CFR 60, Method 18 (Hydrocarbons)	TO-14A (VOC)
Chrysene	TO-13A (PAH)	SW8270M (SVOC)
Dibenz[a,h]anthracene	TO-13A (PAH)	SW8270M (SVOC)
Dibutyl phthalate	SOP CAD 26.3 (Energetics)	SW8270M (SVOC)
1,2-Dichlorobenzene	TO-14A (VOC)	SW8270M (SVOC)
1,3-Dichlorobenzene	TO-14A (VOC)	SW8270M (SVOC)
1,4-Dichlorobenzene	TO-14A (VOC)	SW8270M (SVOC)
2,4-Dinitrotoluene	SOP CAD 26.3 (Energetics)	SW8270M (SVOC)
2,6-Dinitrotoluene	SOP CAD 26.3 (Energetics)	SW8270M (SVOC)
bis(2-Ethylhexyl)phthalate	SOP CAD 26.3 (Energetics)	SW8270M (SVOC)
Fluoranthene	TO-13A (PAH)	SW8270M (SVOC)
Fluorene <sup>a</sup>	TO-13A (PAH)	SW8270M (SVOC)
Hexachlorobutadiene	TO-14A (VOC)	SW8270M (SVOC)
Hexachloroethane	TO-14A (VOC)	SW8270M (SVOC)
Hexane	40 CFR 60, Method 18 (Hydrocarbons)	TO-14A (VOC)
Indeno[1,2,3-cd]pyrene	TO-13A (PAH)	SW8270M (SVOC)
Naphthalene	TO-13A (PAH)	SW8270M (SVOC)
Nitrobenzene	SOP CAD 26.3 (Energetics)	SW8270M (SVOC)
Phenanthrene <sup>a,e</sup>	TO-13A (PAH)	SW8270M (SVOC)
Propylene	40 CFR 60, Method 18 (Hydrocarbons)	TO-14A (VOC)
Pyrene <sup>d,f</sup>	TO-13A (PAH)	SW8270M (SVOC)



TABLE 4 (cont.)

Compound	Selected Method	Other Method Employed
1,2,4-Trichlorobenzene	TO-14A (VOC)	SW8270M (SVOC)
Acetone	TO-11A (Aldehydes)	TO-14A (VOC)
Pentane	40 CFR 60, Method 18 (Hydrocarbons)	TO-14A (VOC)

<sup>a</sup> For DODIC A017, data collected from the SVOC sampling method were used to develop emission factors because this compound was present in the PAH method blank at a level greater than 50 percent of the test values.

<sup>b</sup> For DODIC A518, data collected from the SVOC sampling method were used to develop emission factors because this compound was present in the PAH method blank at a level greater than 20 percent of the test values.

<sup>c</sup> For DODICs A017 and B645, data collected from the SVOC sampling method were used to develop emission factors because this compound had a relative percent difference greater than 100 percent between PAH test samples.

<sup>d</sup> For DODIC B645, data collected from the SVOC sampling method were used to develop emission factors because this compound was present in the PAH method blank at a level greater than 50 percent of the test values.

<sup>e</sup> For DODIC B645, data collected from the SVOC sampling method were used to develop emission factors because this compound was present in the PAH method blank at a level greater than 20 percent of the test values.

<sup>f</sup> For DODIC A017, data collected from the SVOC sampling method were used to develop emission factors because this compound was present in the PAH method blank at a level greater than 20 percent of the test values.

### 3.2.2.3 Tentatively Identified Compounds

During the analysis of the SVOC data, the 20 highest nontarget “peaks” were tentatively identified using computerized mass spectral matching techniques. Similarly, during the analysis of the VOC data, the 20 highest nontarget “peaks” were tentatively identified. Emission factors were developed for these tentatively identified compounds (TICs) if all of the following criteria were met.

1. The TIC corresponded to a unique compound (e.g., ethylbenzene). Emission factors were not developed if the TIC corresponded to a class of compounds (e.g., unknown alcohol).
2. The TIC was not identified using another analysis method that provided higher confidence data. Emission factors were developed based upon the higher confidence analysis method if such data were available.
3. The TIC was not present in the method blank. Emission factors were not developed if the TIC was found in the corresponding method blank.

The number of SVOC that were tentatively identified as unique compounds, were not identified using a higher confidence method, and were not present in the method blank varied from one to three compounds per ordnance. Similarly, the number of VOC that were tentatively identified as unique compounds, were not identified using a higher confidence method, and were not present in the method blank varied from zero to one compound per ordnance. Emission factors were developed for all of these TICs, but because of the uncertainty in the true identity of the TICs, the test data were assigned a “C” rating.

### 3.2.3 Process Information

Ordnance are manufactured to tight tolerances and are expected to deploy in a very repeatable fashion. Consequently, the test data should be assigned an “A” rating based upon this criterion. However, large relative percent differences (i.e., greater than 100 percent) between test runs were noted for several compounds. Specific instances in which these differences were noted are identified in Table 5. The equation below illustrates calculation of relative percent difference:

$$\text{relative percent difference} = \frac{\text{test 1 concentration} - \text{test 2 concentration}}{\text{average of test 1 and test 2 concentrations}} \times 100\%$$

TABLE 5 COMPOUNDS FOR WHICH LARGE RELATIVE PERCENT DIFFERENCES WERE NOTED BETWEEN TEST RUNS

Compound	Applicable DODIC
Acetonitrile	A017
Acrylonitrile	A017
Beryllium	A518
Cobalt	A518
Hexavalent chromium	B627
1,2,3,4,6,7,8-Heptachlorodibenzofuran	A017
Selenium	A518
Silver	A518
Toluene	B645
o-Xylene	B627
Benzaldehyde	A017
Indene	A017, B627
9-Octadecenamide, (Z)-	A017

Due to the large relative percent differences between test runs, the test data specifically identified in Table 5 were assigned a “C” rating. The remainder of the data should be assigned an “A” rating based on this criterion.

### 3.2.4 Analysis and Calculations

The test report,<sup>1</sup> detailed test plan,<sup>2</sup> and analytical data supporting the test report<sup>3</sup> were reviewed to determine whether they contained all of the original raw data, other documentation, and example calculations. Although the test report did not contain raw field data, the data were made available upon request. The test report also lacked certain calibration data. However, the missing information was judged insufficient to result in a downgrade of the test data quality rating.

The raw data and sample calculations presented in the final test report, detailed test plan, and analytical data supporting the test report were reviewed to determine if the emission factors presented in the report could be duplicated. Where differences were found between the emission factors calculated

using the Excel spreadsheets and those presented in the test report, an examination was made to determine the reason for the differences.

Several minor errors were noted in the calculation of the emission factors within the test report, particularly with respect to correcting the sample volumes to standard conditions and the incorporation of analytical detection limits into the emission factors (see Sections 4.1 and 4.2). The emission factors presented in AP-42 are based upon the corrected spreadsheets. Based upon the raw data, other documentation, and the Excel spreadsheet calculations, the test data should be assigned an “A” rating.

Emission factors developed for compounds present in the method blank at levels of 20 percent to 50 percent of both test values were assumed to be biased high. Several compounds met this criterion and are identified in Table 6. For these compounds, the test data were assigned a “B” rating.

TABLE 6 COMPOUNDS FOUND IN THE METHOD BLANK AT LEVELS BETWEEN 20 PERCENT AND 50 PERCENT OF BOTH TEST VALUES

Compound	Applicable DODIC
Aluminum	B627
Antimony	B627
Chromium	B645
Copper	A017
1,2,3,4,6,7,8-Heptachlorodibenzofuran	A017
1,2,3,4,6,7,8-Heptachlorodibenzo-p-dioxin	B627
1,2,3,4,6,7,8,9-Octachlorodibenzo-p-dioxin	A518
Zinc	B627

When compounds were found in the method blank at levels greater than 50 percent of both test values, the data were assumed to be suspect and no emission factors were developed. Several compounds met this criterion and are identified in Table 7.

TABLE 7 COMPOUNDS FOUND IN THE METHOD BLANK AT LEVELS GREATER THAN 50 PERCENT OF BOTH TEST VALUES

Compound	Applicable DODIC
Aluminum	A017
Chromium	A017
Copper	B645
1,2,3,4,6,7,8-Heptachlorodibenzo-p-dioxin	A017, A518, B645
1,2,3,4,6,7,8-Heptachlorodibenzofuran	A518, B627, B645
1,2,3,4,7,8,9-Heptachlorodibenzofuran	A518, B627, B645
1,2,3,4,7,8-Hexachlorodibenzo-p-dioxin	A518, B627, B645
1,2,3,6,7,8-Hexachlorodibenzo-p-dioxin	All DODICs
1,2,3,7,8,9-Hexachlorodibenzo-p-dioxin	All DODICs

TABLE 7 (cont.)

Compound	Applicable DODIC
1,2,3,4,7,8-Hexachlorodibenzofuran	A518, B627, B645
1,2,3,6,7,8-Hexachlorodibenzofuran	A518, B627, B645
1,2,3,7,8,9-Hexachlorodibenzofuran	All DODICs
2,3,4,6,7,8-Hexachlorodibenzofuran	A518, B627, B645
1,2,3,4,6,7,8,9-Octachlorodibenzo-p-dioxin	A017, B627, B645
1,2,3,4,6,7,8,9-Octachlorodibenzofuran	All DODICs
2,3,4,7,8-Pentachlorodibenzofuran	B627
Zinc	A017
Calcium	A017, B627, B645
Magnesium	A017, B645

The test report<sup>1</sup> indicated that the recommended holding times to extraction and subsequent analysis were exceeded for the hexavalent chromium for all DODICs. Specifically:

- For DODICs B627 and B645, the method's recommended holding times from sampling to analysis for the hexavalent chromium samples were exceeded by between 5 and 7 days. These test data were assigned a "B" rating.
- For DODICs A017 and A518, the method's recommended holding times from sampling to analysis for the hexavalent chromium samples were exceeded by between 12 and 18 days. These test data were assigned a "C" rating.

### 3.3 Test Data Quality Ratings

Upon completing the analysis described in the preceding section of this document, the test data quality ratings assigned as a result of the four criteria were reviewed. This review led to a downgrading of some of the test data from an "A" rating to either a "B" rating or a "C" rating. Table 8 identifies the data quality ratings for all compounds that did not receive an "A" rating.

TABLE 8 DOWNGRADED DATA QUALITY RATINGS

Compound	Data Quality Rating	Applicable DODIC
Carbon dioxide	B	All DODICs
Carbon monoxide	B	All DODICs
Oxides of nitrogen	B	All DODICs
Sulfur dioxide	B	All DODICs
Acetonitrile	C	A017
Acrylonitrile	C	A017
Aluminum	B	B627
Antimony	B	B627

TABLE 8 (cont.)

Compound	Data Quality Rating	Applicable DODIC
Beryllium	C	A518
Chromium	B	B645
Hexavalent chromium	B	B645
Hexavalent chromium	C	A017, A518, B627
Cobalt	C	A518
Copper	B	A017
1,2,3,4,6,7,8-Heptachlorodibenzofuran	C	A017
1,2,3,4,6,7,8-Heptachlorodibenzo-p-dioxin	B	B627
1,2,3,4,6,7,8,9-Octachlorodibenzo-p-dioxin	B	A518
Selenium	C	A518
Silver	C	A518
Toluene	C	B645
o-Xylene	C	B627
Zinc	B	B627
Benzaldehyde	C	A017
Benzonitrile	C	A518
1-Butanol, 3-methyl-, acetate	C	B645
Indene	C	A017, B627
Methane, nitro-	C	A017, B645
9-Octadecenamide, (Z)-	C	A017, B627
Phenylethyne	C	B627

#### 4.0 EMISSION FACTOR CALCULATIONS

The methodologies and procedures that were used to develop emission factors from the test data are described in this section. A similar approach was used to calculate emission factors for SVOC and PAH compounds. The calculation steps that were performed for each sample and each configuration are summarized below.

1. The sample volumes associated with the background and test runs were corrected to the EPA Stationary Source Program standard temperature and pressure (i.e., 68°F and 29.92 inches of mercury).
2. For compounds for which more than one test sample was obtained, analytical detection limits were incorporated into the test data.

3. The background compound concentration was calculated by dividing the mass of compound detected during the background run by the background run sample volume corrected to standard conditions.
4. The test compound concentration was calculated by dividing the mass of compound detected during the test run by the test run sample volume corrected to standard conditions.
5. A background-corrected concentration was calculated by subtracting the background concentration from the test concentration.
6. A dilution-corrected concentration was calculated by dividing the background-corrected concentration by the test dilution correction factor.
7. The mass of compound released during the test run was calculated by multiplying the dilution-corrected concentration by the volume of the ECC.
8. Emission factors for each sample and test run were calculated by dividing the mass of compound released by the number of ordnance detonated during the test run or by the NEW detonated during the test run, as appropriate.
9. Average emission factors were calculated for each compound.

Because concentration data (i.e., parts per million by volume [ppmv] or parts per billion by volume [ppbv]) were recorded for VOC, hydrocarbons, FTIR-measured compounds, and CEMS-measured compounds, it was not necessary to calculate a corrected sample volume as described in step 1 or to calculate background and test concentrations as described in steps 3 and 4. Detection limits were applied directly to test compound concentrations as described in step 2. As appropriate, ppmv and ppbv values were converted to mg/m<sup>3</sup>. Emission factors for VOC, hydrocarbons, and CEMS-measured compounds were then estimated in accordance with steps 5 through 9 described above. FTIR-measured compound emission factors were also estimated in accordance with steps 5 through 9 described above, except that step 6, the dilution correction, was not required. FTIR-measured concentrations were determined from initial steady-state points that occurred prior to significant dilution.

Test and background concentrations of TSP, PM-10, PM-2.5, metal, acid gas, hydrogen cyanide, aldehyde, dioxin/furan, total carbon, hexavalent chromium, energetic, and perchlorate compounds were provided by the laboratory. The laboratory calculated the concentrations based upon the sample volumes as measured at actual conditions. Concentration data received from the laboratory were corrected for volume at Stationary Source Program standard conditions and analytical detection limits were incorporated as described in step 2. Emission factors for these compounds were then estimated in accordance with steps 5 through 9 described above.

The following sections describe each of the nine emission factor calculation steps listed above in more detail. In addition, Section 4.10 discusses the calculation of total emission factors for DODIC B627, the warhead of which was previously tested as described in the final test report titled *Sampling Results for AEC Phase V Emission Characterization of Exploding Ordnance and Smoke/Pyrotechnic*<sup>9</sup> and for which emission factors were previously estimated as described in *Report on Revisions to 5<sup>th</sup> Edition AP-42 Chapter 15 - Ordnance Detonation, Emission Factors Developed Based on Phase V-B Testing Conducted at Dugway Proving Ground, Utah*.<sup>10</sup>

#### **4.1 Correction of Sample Volume to Standard Conditions**

Because sample volumes were initially reported at actual conditions, calculations to correct the sample volumes to the EPA Stationary Source Program standard temperature of 68°F and pressure of 29.92 inches of Hg (20°C and 760 mm Hg) were performed. To obtain the sample volume at EPA

Stationary Source Program standard conditions ( $V_{stat}$ ), the sample volume at actual conditions ( $V_{act}$ ) was multiplied by the ratio of pressure at actual conditions ( $P_{act}$ ) to temperature at actual conditions ( $T_{act}$ ) and by the ratio of temperature at Stationary Source Program standard conditions ( $T_{stat}$ ) to pressure at Stationary Source Program standard conditions ( $P_{stat}$ ). This calculation is illustrated by the following equation:

$$V_{stat} = V_{act} \times \frac{P_{act}}{T_{act}} \times \frac{T_{stat}}{P_{stat}}$$

#### 4.2 Incorporation of Analytical Detection Limits to the Test Data

In most cases, more than one test sample was obtained for a specific compound (i.e., more than one test run was conducted). When multiple samples were obtained for the same compound, a comparison was made of all the sample data collected. Based upon the results of the comparison, the following adjustments were made to the test data:

1. If all of the samples indicated that a compound was “not detected,” the sample data were not adjusted.
2. If all of the samples indicated that a compound was detected, the sample data were not adjusted.
3. If one or more of the samples indicated that a compound was detected and one or more of the samples indicated that a compound was not detected, the “not detected” values were replaced with a value equal to one half of the compound’s analytical detection limit. The assumption inherent to this adjustment was that the measured presence of a compound in one or more samples was indicative of the compound’s presence in all samples. The analytical detection limits for each sample were obtained from the analytical data supporting the test report.

#### 4.3 Determination of Background Concentration

For SVOC and PAH compounds, the background compound concentration (BC) was calculated by dividing the mass of compound detected during the background run (Bkgd mass) by the background run sample volume corrected to EPA Stationary Source Program standard conditions (Bkgd  $V_{stat}$ ). The background concentration calculation is illustrated by the following equation:

$$BC = \frac{Bkgd\ mass}{Bkgd\ V_{stat}}$$

The background compound concentrations of TSP, PM-10, PM-2.5, metals, acid gases, hydrogen cyanide, aldehydes, dioxin/furan compounds, total carbon, hexavalent chromium, energetics, and perchlorate provided by the lab were calculated using the sample volume at actual conditions (Bkgd  $V_{act}$ ). In order to correct the concentrations to EPA Stationary Source Program standard conditions (Bkgd  $V_{stat}$ ), the uncorrected concentrations (Bkgd UC) were multiplied by the ratio of volume at actual conditions to volume at standard conditions. This calculation is illustrated by the following equation:

$$BC = Bkgd\ UC \times \frac{Bkgd\ V_{act}}{Bkgd\ V_{stat}}$$

FTIR- and CEMS-measured compounds were not sampled for during the background runs. However, background data were recorded for each test run between the time the FTIR and CEMS began sampling and the time of detonation. The only FTIR- or CEMS-measured compound for which significant background concentrations were recorded was  $CO_2$ . The  $CO_2$  background concentration was

assumed to equal a representative value over the sampling period. Background concentrations for the other FTIR- and CEMS-measured compounds were assumed to be zero.

#### 4.4 Determination of Test Compound Concentration

For SVOC and PAH compounds, the test compound concentration (TC) was calculated by dividing the mass of compound detected during the test run (Test mass) by the test run sample volume corrected to EPA Stationary Source Program standard conditions (Test  $V_{stat}$ ). This test compound calculation is illustrated by the following equation:

$$TC = \frac{\text{Test mass}}{\text{Test } V_{stat}}$$

Test compound concentrations of TSP, PM-10, PM-2.5, metals, acid gases, hydrogen cyanide, aldehydes, dioxin/furan compounds, total carbon, hexavalent chromium, energetics, and perchlorate provided by the lab were calculated using the sample volume at actual conditions. In order to correct the concentrations to EPA Stationary Source Program standard conditions, the uncorrected concentrations (Test UC) were multiplied by the ratio of the volume at actual conditions (Test  $V_{act}$ ) to the volume at EPA Stationary Source Program standard conditions (Test  $V_{stat}$ ). This calculation is illustrated by the following equation:

$$TC = \text{Test UC} \times \frac{\text{Test } V_{act}}{\text{Test } V_{stat}}$$

For VOC, hydrocarbons, FTIR-measured compounds, and CEMS-measured compounds, sample volume correction was not required. VOC and hydrocarbon test concentration values were used directly. Test concentrations of CEMS-measured compounds were determined as the average values measured over the test duration. Test concentrations of FTIR-measured compounds were determined based upon the initial steady-state values reached after detonation. The time at which a compound's concentration reached an initial steady state was determined by visually inspecting plots of the concentration data versus time. The initial steady state corresponds to the time at which a compound was well mixed within the ECC, but before the compound's concentration began to decrease at a steady rate due to dilution.

#### 4.5 Determination of Background-Corrected Concentration

For all compounds, the calculation of the background-corrected concentration (BCC) was dependent on whether the background (BC) and test concentrations (TC) were detected and whether they were less than, equal to, or greater than one another. The procedures used to calculate the background-corrected concentration for each sampling train and compound are described below and are displayed graphically in Figure 1.

1. If the test concentration was not detected (ND), the background-corrected concentration equaled ND.
2. If the test concentration was detected and the background concentration was not detected, the background-corrected concentration equaled the test concentration.
3. If the test and background concentrations were detected and the test concentration was less than or equal to the background concentration, the background-corrected concentration equaled 0.
4. If the test and background concentrations were detected and the test concentration was greater than the background concentration, the background concentration was subtracted from the test concentration. This calculation is illustrated by the following equation:



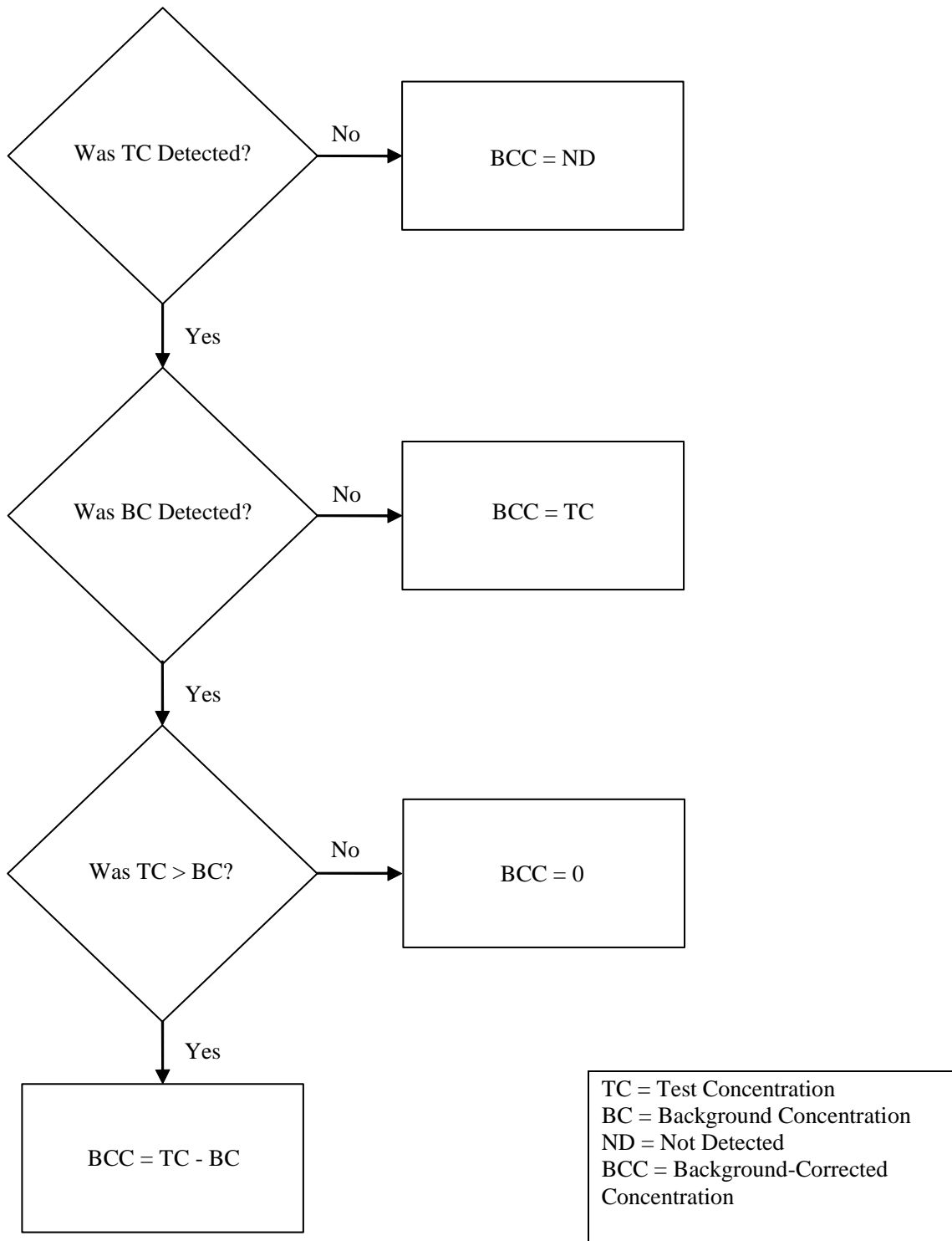

Figure 1 Calculation of background-corrected concentration.

$$BCC = TC - BC$$

#### 4.6 Determination of Dilution-Corrected Concentration

The dilution-corrected concentration (DCC) was calculated by dividing the background-corrected concentration by the applicable test dilution correction factor. This calculation is illustrated by the following equation:

$$DCC = \frac{BCC}{DCF_{test}}$$

With the exception of FTIR-measured compounds, dilution correction factors were obtained from the test contractor.<sup>3</sup> Because the test concentrations of FTIR-measured compounds were obtained prior to dilution, it was not necessary to calculate a dilution corrected concentration for these compounds.

#### 4.7 Determination of Mass of Compound Released

The mass of compound released was calculated by multiplying the dilution-corrected concentration by the volume of the ECC. This calculation is illustrated by the following equation:

$$\text{Mass compound released} = DCC \times ECC \text{ volume}$$

#### 4.8 Determination of Emission Factors

Once the mass of compound released was calculated, two emission factors were developed for each sample and for each test run: the mass of compound released per item (i.e., per single ordnance) and the mass of compound released per pound NEW. The NEW for all ordnance were determined from Reference 3.

#### 4.9 Determination of Average Emission Factors

Steps 1 through 8, as described in Sections 4.1 through 4.8, are applicable to individual samples within individual test runs. The final step in the emission factor calculation process was to calculate average emission factors for each compound in terms of mass released per item and mass released per pound NEW. The average emission factors for each compound were calculated as the arithmetic mean of the individual samples associated with the compound. If all samples indicated that the compound was not detected (ND), then the average emission factor was assigned a value of ND. [Note: The minimum detection levels associated with the compounds that were not detected are presented in Appendix A.]

Total dioxin/furan emission factors were calculated by summing the average emission factors for all dioxin/furan compounds. Samples of energetic materials were collected using both filters and resin packed cartridges. However, the filter and resin were analyzed separately. Because the filter and resin packed cartridge were arranged in series, average emission factors calculated for the filter were added to average emission factors calculated for resin packed cartridge to determine total emission factors.

#### 4.10 Determination of Total Emission Factors for DODIC B627

Under the current test series, emissions generated by the use of the propelling charge associated with DODIC B627 were quantified.<sup>1</sup> However, as described in References 9 and 10, emissions generated by the use of the warhead associated with DODIC B627 were previously quantified. Total emissions

factors, in terms of pounds of emissions per item, were calculated by summing the emission factors for the use of the propelling charge with the emission factors for the use of the warhead. Total emissions factors, in terms of pounds of emissions per pound NEW, were calculated by dividing the total emissions per item by the sum of the NEWs for the propelling charge and the warhead. The emission factors developed for this test series are presented in Appendix A, along with the total emission factors developed for the ordnance.

## 5.0 EMISSION FACTOR RATINGS

The emission factors were appraised in accordance with the rating system specified in Reference 4. Under this rating system, emission factors are assigned a rating from A to E, where an “A” rating is assigned to the highest quality factors. The criteria used to assign a specific emission factor rating are summarized below.

- A** Excellent. The emission factor was developed primarily from A- and B-rated source test data taken from many randomly chosen facilities in the industry population. The source category population was sufficiently specific to minimize variability.
- B** Above average. The emission factor was developed primarily from A- or B-rated test data from a moderate number of facilities. Although no specific bias was evident, it was not clear if the facilities tested represented a random sample of the industry. As with the “A” rating, the source category population was sufficiently specific to minimize variability.
- C** Average. The emission factor was developed primarily from A-, B-, and/or C-rated test data from a reasonable number of facilities. Although no specific bias was evident, it was not clear if the facilities tested represented a random sample of the industry. As with the “A” rating, the source category population was sufficiently specific to minimize variability.
- D** Below average. The emission factor was developed primarily from A-, B-, and C-rated test data from a small number of facilities, and there may have been reason to suspect that these facilities did not represent a random sample of the industry. There also may have been evidence of variability within the source category population.
- E** Poor. The emission factor was developed from C- and D-rated test data from a very limited number of facilities, and there may have been reason to suspect that the facilities tested did not represent a random sample of the industry. There also may have been evidence of variability within the source category population.

Two analyses were conducted to assign ratings to the ordnance emission factors. First, an analysis was conducted on an ordnance-specific basis. Second, an analysis was conducted using all available ordnance emission factor data. The second analysis was conducted to determine whether a sufficient correlation existed between emission factors for different but similar ordnance to allow the number of test data points to be increased to the point that higher emission factor ratings could be assigned than were possible when using the ordnance-specific approach. Both analyses are described below.

### 5.1 Emission Factor Ratings Assigned – Based on Ordnance-Specific Test Data

As previously described, emission factor ratings are dependent upon the test data quality, the number of test data points, the amount of variability present within a source category population, and the randomness of the source category sample. The following test data facts pertain to these rating criteria:

1. As described in Section 3 of this Background Document, the ordnance test data was primarily rated A or B. The test data for a few compounds was rated C.
2. Only two tests were conducted per ordnance.
3. Ordnance are manufactured to very tight tolerance levels so there is little variability within a specific type of ordnance.
4. There was no evidence that suggested the tested items within each type of ordnance were specially selected.

Emission factor ratings were assigned based upon these facts. The rationale used to accept or reject specific emission factor ratings follow.

- A: Rejected. The number of test data points was deemed to be insufficient to assign an A emission factor rating.
- B: Rejected. The number of test data points was deemed to be insufficient to assign a B emission factor rating.
- C: Accepted for most ordnance. The emission factors were developed using A- and B-rated test data, there is little variability among items, and there was no evidence that suggested the tested items were specially selected. Because of the limited number of data points, a C rating was deemed appropriate for this set of circumstances.
- D: Accepted for some ordnance. The emission factors were developed using C-rated test data, there is little variability among items, and there was no evidence that suggested the tested items were specially selected. Because of the limited number of data points, a D rating was deemed appropriate for this set of circumstances.
- E: Rejected. The ordnance described in this report were developed primarily using A- and B-rated test data rather than C- or D-rated data, there is little variability among items, and there was no evidence that suggested the tested items were specially selected. Therefore, an E emission factor rating was deemed inappropriate.

## **5.2 Emission Factor Ratings Assigned – Based on All Available Test Data**

The proceeding sections of this Background Document concern the emission measurement methods, data analysis, and calculations used to develop emission factors for specific ordnance. However, USAEC's ordnance emission factor development program includes more than 200 ordnance that have been tested under more than 25 separate test series. Because many of these ordnance are similar in size and/or chemical composition, a statistical analysis was conducted to assess the similarity of the emission factors developed for similar ordnance. The results of this analysis were used to reevaluate the emission factor ratings assigned on an ordnance-specific basis.

USAEC characterized individual ordnance as falling into one of 17 separate categories, depending upon the size and/or chemical composition of the ordnance. The ordnance and their respective categories are identified in Table 9 along with a comment field describing the number of data points.

Within each of the 17 ordnance categories identified by USAEC, emission factors for each compound were compared. To allow the comparison of emission factors for ordnance with similar constituents but significant differences in net explosive weight, the comparison was made using the normalized emission factor units of mass of compound released per pound NEW. Based upon information provided by EPA,<sup>11</sup> the following procedures were used to assess the data correlation:

TABLE 9 ORDNANCE CATEGORIZATION FOR EMISSION FACTOR CORRELATION ASSESSMENT

Category	DODIC	Ordnance Description	Test Series	Comment
CS	G963 <sup>a</sup>	M73A CS Riot Control Agent Hand Grenade	DPG VI	Data not yet available
	K765 <sup>a</sup>	CS Riot Control Agent Capsule	DPG VI	
Demolition	G900	TH3 AN-M14 Incendiary Grenade	EO 5	20+ data points
	G911	MK3A2 Offensive Hand Grenade	EO 2	
	G911	MK3A2 Offensive Hand Grenade	EO 6	
	K010	M4 Field Incendiary Burster	EO 5	
	K145	M18A1 Antipersonnel Mine	EO 2	
	M023	M112 Demolition Block Charge	EO 1	
	M030	1/4-Pound Demolition Block Charge	EO 1	
	M030	1/4-Pound Demolition Block Charge	EO 3	
	M031	1/2-Pound Demolition Block Charge	DPG IV-A	
	M032	1-Pound Demolition Block Charge	EO 2	
	M032	1-Pound Demolition Block Charge	EO 3	
	M130 <sup>a</sup>	M6 Electric Blasting Cap	DPG VII	
	M130	M6 Electric Blasting Cap	EO 7	
	M131	M7 Non-Electric Blasting Cap	EO 7	
	M241	M10 High Explosive Universal Destructor	DPG IV-B	
	M456	PETN Type 1 Detonating Cord	DPG IV-A	
	M500 <sup>a</sup>	M21 REEF Line Cutter	EO 10	
	M591	M1 Military Dynamite Demolition Block Charge	EO 1	
	M913	M58A3 Linear Demolition Charge	EO 3	
	ML05 <sup>a</sup>	MK24 High Explosive Cutter	EO 11	
	ML09	Linear Demolition Charge, Shaped 20 gr/ft	DPG IV-A	
	ML15	Linear Demolition Charge, Shaped 225 gr/ft	DPG IV-A	
	ML47	M11 Non-Electric Blasting Cap with 30-foot Shock Tube	EO 7	
MM50 <sup>a</sup>	M221 Shaped Charge	EO 11		
MN02	M11 Non-Electric Blasting Cap with 500-foot Shock Tube	EO 7		

TABLE 9 (cont.)

Category	DODIC	Ordnance Description	Test Series	Comment
Demolition, continued	MN03	M11 Non-Electric Blasting Cap with 1,000-foot Shock Tube	EO 7	20+ data points
	MN06	M14 Non-Electric Time Delay Blasting Cap	EO 7	
	MN07 <sup>a</sup>	M15 Delay Blasting Cap	EO 11	
	MN08 <sup>a</sup>	M81 Igniter	EO 9	
	MN68 <sup>a</sup>	M151 Booster Demolition Charge	DPG VIII	
	None	PAX-11, Granular Powder Burn	EO 4	
	None	PAX-11, Molded Pellet Detonation	EO 4	
Fuse	G878 <sup>a</sup>	M228 Practice Hand Grenade Fuse	DPG VI	<10 data points
	K051	M604 Anti-Tank Practice Mine Fuse	EO 6	
	N278 <sup>a</sup>	M564 Mechanical Time and Super Quick (MTSQ) Fuse	EO 11	
	N285 <sup>a</sup>	M577 Fuse	EO 9	
	N286	M582 Mechanical Time and Super Quick (MTSQ) Fuse	EO 7	
	N335	M557 Point Detonating Fuse	EO 5	
	N340	M739A1 Point Detonating Fuse	EO 5	
N464 <sup>a</sup>	M732 Fuse	EO 9		
Grenade	G881	M67 Fragmentation Grenade	EO 1	<10 data points
	G978	M82 Smoke Simulant Screening Grenade Launcher	DPG V-B	
	G982	M83 Terephthalic Acid (TA) Smoke Practice Hand Grenade	DPG V-A	
	GG09 <sup>a</sup>	M84 Non-Lethal Stun Hand Grenade	EO 12	
Illumination	B535	M583A1 40-mm White Star Parachute Cartridge	DPG IV-B	20+ data points
	B536	M585 40-mm White Star Cluster Cartridge	DPG IV-B	
	B627	M83A3 60-mm Illuminating Cartridge (projectile only)	DPG V-B	
	D505	M485A2 155-mm Illumination Round (projectile only)	DPG I	
	L305	M195 Green Star Parachute Signal Flare	DPG I	
	L306	M158 Red Star Cluster Signal Illumination	DPG II	
	L307	M159 White Star Cluster Signal Illumination	DPG II	

TABLE 9 (cont.)

Category	DODIC	Ordnance Description	Test Series	Comment
Illumination, continued	L311	M126A1 Red Star Parachute Signal Flare	DPG II	20+ data points
	L312	M127A1 White Star Parachute Signal Flare	DPG I	
	L314	M125A1 Green Star Cluster Signal Flare	DPG I	
	L367 <sup>a</sup>	M22 Anti-Tank, Guided Missile, and Rocket Launching Simulator	DPG VI	
	L410 <sup>a</sup>	M206 Aircraft Countermeasure Flare	DPG VI	
Inert	HA11 <sup>a</sup>	Rocket, 2.75-inch Flechette with M255A1 Warhead	DPG VIII	Data not yet available
Large	C511	M490 105-mm Target Practice Tracer Cartridge (M13 tracer only)	EO 6	Only 1 data point yet available
	C784 <sup>a</sup>	M831 120-mm Target Practice Tracer Cartridge	EO 12	
	C785 <sup>a</sup>	M865 120-mm Target Practice Discarding Sabot Tracer Cartridge	EO 12	
Medium	BA11 <sup>a</sup>	M1001 40-mm HVCC Cartridge	EO 12	Data not yet available
	BA15 <sup>a</sup>	M769 60-mm FRP Cartridge	EO 12	
Medium-FP	A652	M220 20-mm Target Practice Tracer Cartridge	FP 9	10+ data points
	A940	M910 25-mm Target Practice Discarding Sabot Tracer Cartridge	FP 8	
	A976	M793 25-mm Target Practice Tracer Cartridge	FP 8	
	B129 <sup>a</sup>	M789 30-mm Cartridge	EO 9	
	B505 <sup>a</sup>	M662 40-mm Red Star Parachute Cartridge	DPG VIII	
	B519	M781 40-mm Practice Cartridge	FP 2	
	B584	M918 40-mm Practice Cartridge	FP 2	
Mine	K042 <sup>a</sup>	M88 Volcano Practice Canister Mine	DPG VIII	Data not yet available
Mortar	CA03	XM929 120-mm White Phosphorus Smoke Cartridge (projectile only)	DPG V-B	Only 1 data point
Projectile	B542	M430 40-mm High Explosive Dual Purpose (HEDP) Cartridge (projectile only)	EO 3	10+ data points
	B571	M383 40-mm High Explosive Cartridge (projectile only)	EO 3	
	B632	M49A4 60-mm High Explosive Cartridge (projectile only)	EO 3	

TABLE 9 (cont.)

Category	DODIC	Ordnance Description	Test Series	Comment
Projectile, continued	B642	M720 60-mm High Explosive Cartridge (projectile only)	EO 6	10+ data points
	BZ-13 <sup>a</sup>	M888 60-mm Cartridge	EO 11	
	C995	M136 AT4 Recoilless Rifle, 84-mm Cartridge (projectile only)	EO 3	
	H557	M72A3 66-mm High Explosive Antitank Rocket (projectile only)	EO 1	
	H708 <sup>a</sup>	M73 35-mm Subcaliber Practice Rocket	DPG VIII	
	None	M720 60-mm Mortar HE Cartridge with PAX-21 Charge (projectile only)	EO 8	
	PJ02	FIM-92A Stinger-Basic Guided Missile (projectile only)	EO 6	
Propellant	B627	M83A3 60-mm Illuminating Cartridge (propelling charge only)	FP 10	20+ data points
	B642	M720 60-mm High Explosive Cartridge (propelling charge only)	FP 4	
	B645	M766 60-mm Short Range Practice Mortar Cartridge (propelling charge only)	FP 10	
	C226	M301A3 81-mm Illuminating Cartridge (propelling charge only)	FP 4	
	C379	M934 120-mm High Explosive Cartridge (Zone 1 - propelling charge only)	FP 8	
	C511	M490 105-mm Target Practice Tracer Cartridge (propelling charge only)	FP 5	
	C784	M831 120-mm Target Practice Tracer Cartridge (propelling charge only)	FP 5	
	C785	M865 120-mm Target Practice Discarding Sabot Tracer Cartridge (propelling charge only)	FP 5	
	C868	M821 81-mm High Explosive Cartridge (propelling charge only)	FP 4	
	C876	M880 81-mm Target Practice Short Range Cartridge (propelling charge only)	FP 4	
	CA09	M931 120-mm Full Range Practice Cartridge (Zone 1 - propelling charge only)	FP 8	
	CA09	M931 120-mm Full Range Practice Cartridge (Zone 4 - propelling charge)	FP 8	



TABLE 9 (cont.)

Category	DODIC	Ordnance Description	Test Series	Comment
Propellant, continued	D533	M119A2 155-mm Propelling Charge (Zone 7)	FP 5	20+ data points
	D540	M3 155-mm Propelling Charge (Zone 3, M199 Cannon)	FP 1	
	D540	M3 155-mm Propelling Charge (Zone 3, M199 Cannon)	FP 5	
	D540	M3 155-mm Propelling Charge (Zone 3, M284 Cannon)	FP 1	
	D540	M3 155-mm Propelling Charge (Zone 5, M199 Cannon)	FP 1	
	D540	M3A1 155-mm Propelling Charge (Zone 3, M199 Cannon)	FP 1	
	D540	M3A1 155-mm Propelling Charge (Zone 3, M284 Cannon)	FP 1	
	D541	M4A2 155-mm Propelling Charge (Zone 7)	FP 5	
	M174 <sup>a</sup>	MK209 Impulse Cartridge	EO 10	
	M842 <sup>a</sup>	M1 Squib	Unclear	
	MD73 <sup>a</sup>	M796 Impulse Cartridge	EO 10	
	MN60 <sup>a</sup>	M79 Igniter	EO 9	
	PJ02	FIM-92A Stinger-Basic Guided Missile (launch motor)	EO 5	
	PJ02	FIM-92A Stinger-Basic Guided Missile (flight motor)	FP 7	
Pyrotechnic	H975 <sup>a</sup>	Rocket, 2.75-inch M274 Signature Smoke with H872 Warhead	DPG VIII	20+ data points
	L366	M74A1 Projectile Air Burst Simulator	DPG IV-B	
	L495	M49A1 Surface Trip Flare	DPG II	
	L508 <sup>a</sup>	M72 Red Railroad Warning Fuse	DPG VI	
	L592	TOW Blast Simulator	DPG V-A	
	L594	M115A2 Ground Burst Simulator	DPG I	
	L595 <sup>a</sup>	M9 Liquid Projectile Air Burst Simulator	EO 12	
	L596	M110 Flash Artillery Simulator	DPG I	
	L598	M117 Flash Booby Trap Simulator	DPG I	
	L599	M118 Illuminating Booby Trap Simulator	DPG II	
	L600	M119 Whistling Booby Trap Simulator	DPG II	

TABLE 9 (cont.)

Category	DODIC	Ordnance Description	Test Series	Comment
Pyrotechnic, continued	L601	M116A1 Hand Grenade Simulator	DPG I	20+ data points
	L602	M21 Artillery Flash Simulator	DPG IV-B	
	L709	M25 Target Hit Simulator	EO 2	
	L709	XM25 Target Hit Simulator	DPG V-B	
	L720	M26 Target Kill Simulator	EO 6	
	M327 <sup>a</sup>	Coupling Base Firing Device	EO 10	
	M448 <sup>a</sup>	M2 Percussion Detonator	EO 11	
	M626 <sup>a</sup>	M1 Push Type Demolition Firing Device	EO 9	
	M627 <sup>a</sup>	M5 Pressure Release Igniter	EO 10	
	M630	M1 Pull Type Demolition Firing Device	DPG V-A	
	M630 <sup>a</sup>	M1 Pull Type Demolition Firing Device	EO 9	
	M670 <sup>a</sup>	M700 Blasting Fuse	EO 11	
	M766 <sup>a</sup>	M60 Igniter	EO 9	
	ML03 <sup>a</sup>	M142 Firing Device	EO 11	
Rocket/Missile	H459	Rocket, 2.75-inch Flechette, MK40 Mod 3 Motor (propelling rocket only)	FP 7	10+ data points
	H557	M72A3 66-mm High Explosive Antitank Rocket (propelling rocket only)	FP 4	
	H557	M72A3 66-mm High Explosive Antitank Rocket (propelling rocket only)	FP 7	
	H708	M73 35-mm Subcaliber Practice Rocket (motor only)	FP 9	
	H974	Rocket, 2.75-inch M267 Practice Warhead, MK66 Mod 3 Motor (propelling rocket only)	FP 7	
Small Arm-FP	A010	M220 10 Gage Blank/Subcaliber Salute Cartridge	FP 9	20+ data points
	A011	12 Gage #00 Shot Cartridge	FP 9	
	A017	12 Gage #9 Shot Cartridge	FP 10	
	A059	M855 5.56-mm Ball Cartridge (fired from the M16A1 Rifle)	FP 3	
	A059	M855 5.56-mm Ball Cartridge (fired from the M16A2 Rifle)	FP 3	
	A059	M855 5.56-mm Ball Cartridge (No-Lead)	FP 4	
	A063	M856 5.56-mm Tracer Cartridge	FP 3	
	A065	M862 5.56-mm Practice Ball Cartridge	FP 3	

TABLE 9 (cont.)

Category	DODIC	Ordnance Description	Test Series	Comment
Small Arm-FP, continued	A066	M193 5.56-mm Ball Cartridge	FP 6	20+ data points
	A068	M196 5.56-mm Tracer Cartridge	FP 6	
	A080	M200 5.56-mm Blank Cartridge	FP 3	
	A086	.22 Caliber Long Rifle Ball Cartridge	FP 4	
	A106	.22 Caliber Standard Velocity Long Rifle Ball Cartridge	FP 4	
	A111	M82 7.62-mm Blank Cartridge	FP 3	
	A131	M62 7.62-mm Tracer Cartridge	FP 6	
	A136	M118 7.62-mm Ball Match Cartridge	FP 6	
	A143	M80 7.62-mm Ball Cartridge	FP 3	
	A171	M852 7.62-mm Ball Match Cartridge	FP 6	
	A182	M1 .30 Caliber Ball Cartridge	FP 6	
	A212	M2 .30 Caliber Ball Cartridge	FP 6	
	A218	M25 .30 Caliber Tracer Cartridge	FP 9	
	A247	M72 .30 Caliber Ball Match Cartridge	FP 6	
	A363	M882 9-mm Ball Cartridge	FP 3	
	A365	M181A1 14.5-mm Artillery Training Cartridge	DPG V-A	
	A366 <sup>a</sup>	M182 14.5-mm Cartridge	EO 11	
	A400	M41 .38 Caliber Special Ball Cartridge	FP 9	
	A403	.38 Caliber Special Blank Cartridge	FP 9	
	A475	M1911 .45 Caliber Ball Cartridge	FP 3	
	A518	M903 .50 Caliber SLAP Ball Cartridge	FP 9	
	A518	M962 .50 Caliber SLAP-Tracer Cartridge	FP 10	
	A525	M2 .50 Caliber Armor Piercing Cartridge	FP 8	
A557	M17 .50 Caliber Tracer Cartridge	FP 3		
A557	M33 .50 Caliber Ball Cartridge	FP 3		
A598	M1A1 .50 Caliber Blank Cartridge	FP 3		
Smoke	C870 <sup>a</sup>	M819 81-mm Red Phosphorous Smoke (IUK)	DPG VII	10+ data points
	G815 <sup>a</sup>	Red Phosphorous Smoke Screening Grenade Launcher (UK)	DPG VII	
	G930	AN-M8 Hexachloroethane (HC) Smoke Hand Grenade	DPG V-A	
	G940	M18 Green Smoke Hand Grenade	DPG III	

TABLE 9 (cont.)

Category	DODIC	Ordnance Description	Test Series	Comment
Smoke, continued	G945	M18 Yellow Smoke Hand Grenade	DPG III	10+ data points
	G950	M18 Red Smoke Hand Grenade	DPG III	
	G950	M18 Red Smoke Hand Grenade (new formulation)	DPG V-A	
	G955	M18 Violet Smoke Hand Grenade	DPG III	
	G955	M18 Violet Smoke Hand Grenade (new formulation)	DPG V-A	
	K866 <sup>a</sup>	ABC-M5 HC Ground Smoke Pot (MILES)	DPG VII	
	K867 <sup>a</sup>	M4A2 Floating Smoke Pot	DPG VII	

<sup>a</sup> Although testing may have been completed, emission factors for this ordnance have not yet been analyzed for inclusion in AP-42; therefore, these data were not included when the data correlation was assessed.

1. The relative standard deviation, defined as the standard deviation divided by the mean, was calculated for each compound within each ordnance category.
2. If the relative standard deviation was less than 1.0, the evaluated emission factors were considered to demonstrate good correlation. As such, the rating for these emission factors could be elevated to a maximum of an A, depending on the number of data points within the evaluated ordnance category.
3. If the relative standard deviation was between 1.0 and 2.0, the evaluated emission factors were considered to demonstrate fair correlation. As such, the rating for these emission factors could be elevated to a maximum of a B, depending on the number of data points within the evaluated ordnance category.
4. If the relative standard deviation was greater than 2.0, the evaluated emission factors were considered to demonstrate poor correlation. As such, the emission factor rating could not be elevated, regardless of the amount of data available.

A poor correlation between emission factors was not necessarily construed as being indicative of poor test data. Rather, a poor correlation was more likely to indicate that the ordnance included in the category were not as similar in nature as anticipated by USAEC when the ordnance categories were defined.

In addition to assessing the data correlation, an assessment was made of the number of test data points available within each of the 17 ordnance categories. Because each ordnance test consisted of two test data points (i.e., two test runs per ordnance or two independent sampling trains were used during an ordnance test), the number of test data points available in each of the ordnance categories varied from 2 to 66. Based upon information provided by EPA,<sup>11</sup> the following assumptions were used to assess whether sufficient category-specific test data points were available to justify elevating the emission factor ratings based on ordnance-specific data only:

1. If 20 or more data points were available, the emission factor rating could be elevated to a maximum of an A, provided that the data also demonstrated a good correlation.
2. If at least 10 but less than 20 data points were available, the emission factor rating could be elevated to a maximum of a B, provided that the data also demonstrated a good correlation.

3. If less than 10 data points were available, the emission factor rating could not be elevated, regardless of the data correlation.
4. If the data demonstrated a fair correlation and 20 or more data points were available, the emission factor rating could be elevated to a maximum of a B.
5. If the data demonstrated a fair correlation and at least 10 but less than 20 data points were available, the emission factor rating could be elevated to a maximum of a C.

Using the criteria specified above, the emission factor ratings assigned to ordnance in each of the 17 ordnance categories were reevaluated. This evaluation indicated that some of the emission factor ratings associated with ordnance included in nine categories could be elevated from a C or D rating to an A or B rating. These nine categories are:

1. Demolition
2. Illumination
3. Medium – Firing Point
4. Projectiles
5. Propellants
6. Pyrotechnics
7. Rocket/Missile
8. Small Arms – Firing Point
9. Smokes

A final assessment was made as to the emission factor rating assigned based on ordnance-specific test data only. If the original emission factor data rating assigned was a C, then the emission factor rating was elevated to an A or B, as appropriate, based upon the data for the whole ordnance category. If the original emission factor data rating assigned was a D, then the emission factor rating was elevated to a B or C, as appropriate, based upon the data for the whole ordnance category. The analysis is documented in an Excel spreadsheet that is located on the EPA website at: <http://www.epa.gov/ttn/chief/ap42/index.html>.

Within the current test series, DODICs A017 and A518, were included in the Small Arms – Firing Point category, which included more than 20 test data points. As a result, some emission factor ratings associated with these ordnance were elevated. DODICs B627 and B645 were included in the Propellant category, which included more than 20 data points. As a result, some emission factor ratings associated with these ordnance were also elevated. The emission factor ratings assigned are presented in Appendix A.

## 6.0 REFERENCES

1. *Report No.10 for the Firing Point Emission Study, Phase II*, Military Environmental Technology Demonstration Center, U.S. Army Aberdeen Test Center, Aberdeen Proving Ground, MD, September 2006.
2. *Detailed Test Plan No.10 for the Firing Point Emission Study, Phase II*, Military Environmental Technology Demonstration Center, U.S. Army Aberdeen Test Center, Aberdeen Proving Ground, MD, June 2004.
3. Supporting information including Excel spreadsheets, analytical results, field notes, and case summaries supplied upon request by the Applied Science Test Team – Chemistry Unit, U.S. Army Aberdeen Test Center, Aberdeen Proving Ground, MD, January 2007.

4. *Procedures for Preparing Emission Factor Documents*, EPA-454/R-95-015, U.S. Environmental Protection Agency, Research Triangle Park, NC, November 1997.
5. *Draft Detailed Procedures for Preparing Emission Factors*, U.S. Environmental Protection Agency, Research Triangle Park, NC, June 2006.
6. *Compendium of Methods for the Determination of Toxic Organic Compounds in Ambient Air*, Second Supplement, EPA/600/4-89/018, U.S. Environmental Protection Agency, Research Triangle Park, NC, June 1988.
7. *Test Methods for Evaluating Solid Waste, Physical/Chemical Methods (SW-846)*, U.S. Environmental Protection Agency, <http://www.epa.gov/epaoswer/hazwaste/test/sw846.htm>.
8. *National Institute for Occupational Safety and Health (NIOSH) Manual of Analytical Methods (NMAM), Fourth Edition*, National Institute for Occupational Safety and Health, Cincinnati, OH.
9. *Sampling Results for AEC Phase V Emission Characterization of Exploding Ordnance and Smoke/Pyrotechnics, Revision 1*, URS Group, Inc., Oak Ridge, TN, February 2007.
10. *Background Document, Report on Revisions to 5<sup>th</sup> Edition AP-42 Chapter 15 - Ordnance Detonation, Emission Factors Developed Based on Phase V-B Testing Conducted at Dugway Proving Ground, Utah*, MACTEC Federal Programs, Inc., Research Triangle Park, NC, March 2007.
11. Information regarding the relationship between emission factor data correlation, the number of data points available, and the resulting emission factor rating assigned supplied upon request by Mr. Ron Myers, Measurement Policy Group, Office of Air Quality Planning and Standards, U.S. Environmental Protection Agency, Research Triangle Park, NC, June 2006.

**APPENDIX A**

**COMPOUNDS ANALYZED AND EMISSION FACTORS DEVELOPED FOR ORDNANCE  
INCLUDED IN FIRING POINT EMISSION STUDY PHASE II SERIES 10 TESTING AT  
ABERDEEN PROVING GROUND, MARYLAND**

DRAFT

This page left blank intentionally.

DRAFT



TABLE A1 COMPOUNDS ANALYZED AND EMISSION FACTORS DEVELOPED FOR  
DODIC A017, 12 GAGE #9 SHOT CARTRIDGE

CASRN <sup>a</sup>	Compound	Emission Factor <sup>b,c</sup>		Minimum Detection Level mg/m <sup>3,e</sup>
		lb per item	lb per lb NEW <sup>d</sup>	
Carbon Dioxide, Criteria Pollutants, Methane, and Total Suspended Particulate				
124-38-9	Carbon dioxide <sup>f</sup>	8.3 E-04	3.1 E-01	--
630-08-0	Carbon monoxide <sup>f</sup>	1.0 E-03	3.7 E-01	--
7439-92-1	Lead	7.4 E-06	2.8 E-03	--
74-82-8	Methane <sup>f</sup>	1.1 E-05	4.2 E-03	--
--	Oxides of nitrogen <sup>g</sup>	2.1 E-05	7.8 E-03	--
--	PM-2.5 <sup>g</sup>	2.0 E-05	7.4 E-03	--
--	PM-10 <sup>g</sup>	2.1 E-05	7.8 E-03	--
7446-09-5	Sulfur dioxide	ND	ND	2.7 E-01
12789-66-1	Total suspended particulate <sup>g</sup>	2.4 E-05	8.8 E-03	--
Hazardous Air Pollutants and Toxic Chemicals				
83-32-9	Acenaphthene <sup>f</sup>	ND	ND	1.7 E-02
208-96-8	Acenaphthylene <sup>g</sup>	5.2 E-09	1.9 E-06	--
75-07-0	Acetaldehyde <sup>f</sup>	2.6 E-07	9.5 E-05	--
75-05-8	Acetonitrile <sup>h</sup>	2.7 E-07	1.0 E-04	--
107-02-8	Acrolein <sup>g</sup>	ND	ND	7.6 E-03
107-13-1	Acrylonitrile <sup>h</sup>	5.6 E-08	2.1 E-05	--
107-05-1	Allyl chloride	ND	ND	1.6 E-03
7664-41-7	Ammonia <sup>f</sup>	ND	ND	3.5 E-01
120-12-7	Anthracene <sup>g</sup>	ND	ND	1.7 E-02
7440-36-0	Antimony <sup>g</sup>	3.2 E-09	1.2 E-06	--
7440-38-2	Arsenic <sup>g</sup>	9.4 E-10	3.5 E-07	--
7440-39-3	Barium <sup>g</sup>	3.2 E-06	1.2 E-03	--
71-43-2	Benzene <sup>g</sup>	2.4 E-06	8.9 E-04	--
56-55-3	Benzo[a]anthracene <sup>g</sup>	1.3 E-10	4.7 E-08	--
205-99-2	Benzo[b]fluoranthene <sup>g</sup>	4.7 E-10	1.7 E-07	--
207-08-9	Benzo[k]fluoranthene <sup>f</sup>	2.7 E-10	9.9 E-08	--
191-24-2	Benzo[g,h,i]perylene <sup>f</sup>	4.0 E-09	1.5 E-06	--
50-32-8	Benzo[a]pyrene <sup>f</sup>	1.0 E-09	3.8 E-07	--
192-97-2	Benzo[e]pyrene <sup>g</sup>	8.8 E-10	3.3 E-07	--
7440-41-7	Beryllium	ND	ND	4.0 E-04
75-25-2	Bromoform	ND	ND	2.1 E-03
74-83-9	Bromomethane	ND	ND	7.9 E-04
101-55-3	4-Bromophenylphenylether	ND	ND	1.7 E-02

TABLE A1 (cont.)

CASRN <sup>a</sup>	Compound	Emission Factor <sup>b,c</sup>		Minimum Detection Level mg/m <sup>3,e</sup>
		lb per item	lb per lb NEW <sup>d</sup>	
106-99-0	1,3-Butadiene <sup>f</sup>	ND	ND	4.5 E-02
75-65-0	t-Butyl alcohol	ND	ND	6.2 E-04
85-68-7	Butylbenzylphthalate	ND	ND	1.7 E-02
123-72-8	Butyraldehyde	ND	ND	7.6 E-03
7440-43-9	Cadmium	2.0 E-08	7.6 E-06	--
75-15-0	Carbon disulfide <sup>g</sup>	ND	ND	1.6 E-03
56-23-5	Carbon tetrachloride	ND	ND	1.3 E-03
106-47-8	4-Chloroaniline	ND	ND	1.7 E-02
108-90-7	Chlorobenzene	ND	ND	9.4 E-04
75-45-6	Chlorodifluoromethane	ND	ND	3.6 E-03
75-00-3	Chloroethane	ND	ND	5.4 E-04
111-91-1	bis(2-Chloroethoxy)methane	ND	ND	1.7 E-02
111-44-4	bis(2-Chloroethyl)ether	ND	ND	1.7 E-02
67-66-3	Chloroform	ND	ND	9.9 E-04
74-87-3	Chloromethane <sup>f</sup>	ND	ND	4.2 E-04
91-58-7	2-Chloronaphthalene	ND	ND	1.7 E-02
95-57-8	2-Chlorophenol	ND	ND	1.7 E-02
7005-72-3	4-Chlorophenyl-phenylether	ND	ND	1.7 E-02
18540-29-9	Hexavalent chromium <sup>i</sup>	1.4 E-06	5.2 E-04	--
218-01-9	Chrysene <sup>g</sup>	1.1 E-10	4.1 E-08	--
7440-48-4	Cobalt	ND	ND	4.0 E-04
7440-50-8	Copper <sup>j</sup>	1.6 E-08	5.8 E-06	--
106-44-5	p-Cresol	ND	ND	1.7 E-02
4170-30-3	Crotonaldehyde	ND	ND	7.6 E-03
98-82-8	Cumene	ND	ND	1.0 E-03
57-12-5	Particulate cyanide <sup>f</sup>	ND	ND	1.3 E-02
53-70-3	Dibenz[a,h]anthracene <sup>f</sup>	ND	ND	1.7 E-05
132-64-9	Dibenzofuran	ND	ND	1.7 E-02
106-93-4	1,2-Dibromoethane	ND	ND	1.6 E-03
84-74-2	Dibutyl phthalate	ND	ND	1.3 E-03
95-50-1	1,2-Dichlorobenzene	ND	ND	3.1 E-03
541-73-1	1,3-Dichlorobenzene	ND	ND	3.1 E-03
106-46-7	1,4-Dichlorobenzene	ND	ND	3.1 E-03
75-27-4	Dichlorobromomethane	ND	ND	1.4 E-03

TABLE A1 (cont.)

CASRN <sup>a</sup>	Compound	Emission Factor <sup>b,c</sup>		Minimum Detection Level mg/m <sup>3,e</sup>
		lb per item	lb per lb NEW <sup>d</sup>	
75-71-8	Dichlorodifluoromethane	ND	ND	1.0 E-03
75-34-3	1,1-Dichloroethane	ND	ND	8.2 E-04
107-06-2	1,2-Dichloroethane <sup>f</sup>	ND	ND	8.2 E-04
75-43-4	Dichlorofluoromethane	ND	ND	8.6 E-04
120-83-2	2,4-Dichlorophenol	ND	ND	1.7 E-02
78-87-5	1,2-Dichloropropane	ND	ND	9.4 E-04
10061-02-6	trans-1,3-Dichloropropene	ND	ND	9.2 E-04
76-14-2	Dichlorotetrafluoroethane	ND	ND	1.4 E-03
105-67-9	2,4-Dimethylphenol	ND	ND	1.7 E-02
131-11-3	Dimethyl phthalate	ND	ND	1.7 E-02
99-65-0	1,3-Dinitrobenzene	ND	ND	6.6 E-04
534-52-1	4,6-Dinitro-2-methylphenol	ND	ND	1.7 E-02
51-28-5	2,4-Dinitrophenol	ND	ND	1.7 E-02
121-14-2	2,4-Dinitrotoluene	ND	ND	6.6 E-04
606-20-2	2,6-Dinitrotoluene	ND	ND	6.6 E-04
123-91-1	1,4-Dioxane	ND	ND	7.3 E-04
--	Total dioxin/furan compounds <sup>g</sup>	1.0 E-13	3.9 E-11	--
122-39-4	Diphenyl amine	ND	ND	1.3 E-03
140-88-5	Ethyl acrylate	ND	ND	8.3 E-04
100-41-4	Ethylbenzene <sup>g</sup>	ND	ND	8.8 E-04
74-85-1	Ethylene <sup>g</sup>	4.5 E-06	1.7 E-03	--
117-81-7	bis(2-Ethylhexyl)phthalate	ND	ND	1.3 E-03
206-44-0	Fluoranthene <sup>g</sup>	1.3 E-10	4.6 E-08	--
86-73-7	Fluorene <sup>g</sup>	ND	ND	1.7 E-02
50-00-0	Formaldehyde	3.9 E-07	1.4 E-04	--
76-13-1	Freon 113	ND	ND	3.9 E-03
67562-39-4	1,2,3,4,6,7,8-Heptachlorodibenzofuran <sup>i</sup>	1.0 E-13	3.9 E-11	--
55673-89-7	1,2,3,4,7,8,9-Heptachlorodibenzofuran	ND	ND	5.1 E-09
118-74-1	Hexachlorobenzene	ND	ND	1.7 E-02
87-68-3	Hexachlorobutadiene	ND	ND	5.4 E-03
77-47-4	Hexachlorocyclopentadiene	ND	ND	1.7 E-02
39227-28-6	1,2,3,4,7,8-Hexachlorodibenzo-p-dioxin	ND	ND	2.1 E-09

TABLE A1 (cont.)

CASRN <sup>a</sup>	Compound	Emission Factor <sup>b,c</sup>		Minimum Detection Level mg/m <sup>3,e</sup>
		lb per item	lb per lb NEW <sup>d</sup>	
70648-26-9	1,2,3,4,7,8-Hexachlorodibenzofuran <sup>g</sup>	ND	ND	3.0 E-09
57117-44-9	1,2,3,6,7,8-Hexachlorodibenzofuran <sup>g</sup>	ND	ND	2.9 E-09
72918-21-9	1,2,3,7,8,9-Hexachlorodibenzofuran	ND	ND	3.2 E-09
60851-34-5	2,3,4,6,7,8-Hexachlorodibenzofuran	ND	ND	3.0 E-09
67-72-1	Hexachloroethane	ND	ND	2.0 E-03
110-54-3	Hexane <sup>g</sup>	ND	ND	7.2 E-02
7647-01-0	Hydrochloric acid <sup>g</sup>	ND	ND	1.0 E-01
74-90-8	Hydrogen cyanide <sup>g</sup>	1.2 E-06	4.6 E-04	--
7664-39-3	Hydrogen fluoride	ND	ND	1.9 E-01
193-39-5	Indeno[1,2,3-cd]pyrene <sup>f</sup>	1.1 E-09	4.0 E-07	--
78-59-1	Isophorone	ND	ND	1.7 E-02
7439-96-5	Manganese	1.7 E-09	6.4 E-07	--
96-33-3	Methyl acrylate	ND	ND	7.2 E-04
74-95-3	Methylene bromide	ND	ND	1.4 E-03
75-09-2	Methylene chloride <sup>g</sup>	2.5 E-06	9.2 E-04	--
74-88-4	Methyl iodide	ND	ND	1.2 E-03
108-10-1	Methyl isobutyl ketone	ND	ND	2.1 E-03
80-62-6	Methyl methacrylate	ND	ND	8.3 E-04
91-57-6	2-Methylnaphthalene	ND	ND	1.7 E-02
95-48-7	2-Methylphenol	ND	ND	1.7 E-02
1634-04-4	Methyl tert-butyl ether	ND	ND	7.3 E-04
91-20-3	Naphthalene <sup>f</sup>	4.4 E-08	1.6 E-05	--
7440-02-0	Nickel	1.6 E-09	5.8 E-07	--
7697-37-2	Nitric acid	ND	ND	1.1 E-01
100-01-6	4-Nitroaniline	ND	ND	1.7 E-02
98-95-3	Nitrobenzene	ND	ND	6.6 E-04
55-63-0	Nitroglycerin	6.6 E-09	2.5 E-06	--
88-75-5	2-Nitrophenol	ND	ND	1.7 E-02
100-02-7	4-Nitrophenol	ND	ND	1.7 E-02

TABLE A1 (cont.)

CASRN <sup>a</sup>	Compound	Emission Factor <sup>b,c</sup>		Minimum Detection Level mg/m <sup>3,e</sup>
		lb per item	lb per lb NEW <sup>d</sup>	
62-75-9	n-Nitrosodimethylamine	ND	ND	1.7 E-02
86-30-6	n-Nitrosodiphenylamine	ND	ND	1.7 E-02
621-64-7	n-Nitroso-di-n-propylamine	ND	ND	1.7 E-02
40321-76-4	1,2,3,7,8-Pentachlorodibenzo-p-dioxin	ND	ND	3.8 E-09
57117-41-6	1,2,3,7,8-Pentachlorodibenzofuran <sup>g</sup>	ND	ND	2.9 E-09
57117-31-4	2,3,4,7,8-Pentachlorodibenzofuran	ND	ND	2.7 E-09
87-86-5	Pentachlorophenol	ND	ND	1.7 E-02
85-01-8	Phenanthrene <sup>g</sup>	ND	ND	1.7 E-02
108-95-2	Phenol	ND	ND	1.7 E-02
123-38-6	Propionaldehyde <sup>g</sup>	ND	ND	7.6 E-03
115-07-1	Propylene <sup>f</sup>	6.5 E-07	2.4 E-04	--
129-00-0	Pyrene <sup>g</sup>	ND	ND	1.7 E-02
7782-49-2	Selenium	3.1 E-09	1.2 E-06	--
7440-22-4	Silver	ND	ND	4.0 E-04
100-42-5	Styrene <sup>f</sup>	2.0 E-08	7.4 E-06	--
7664-93-9	Sulfuric acid	ND	ND	1.2 E-01
1746-01-6	2,3,7,8-Tetrachlorodibenzo-p-dioxin <sup>g</sup>	ND	ND	2.0 E-09
51207-31-9	2,3,7,8-Tetrachlorodibenzofuran	ND	ND	1.5 E-09
630-20-6	1,1,1,2-Tetrachloroethane	ND	ND	1.4 E-03
79-34-5	1,1,2,2-Tetrachloroethane	ND	ND	1.4 E-03
127-18-4	Tetrachloroethylene	ND	ND	1.4 E-03
7440-28-0	Thallium	1.7 E-09	6.4 E-07	--
108-88-3	Toluene <sup>g</sup>	1.0 E-07	3.7 E-05	--
120-82-1	1,2,4-Trichlorobenzene	ND	ND	7.5 E-03
71-55-6	1,1,1-Trichloroethane <sup>g</sup>	ND	ND	1.1 E-03
79-00-5	1,1,2-Trichloroethane	ND	ND	1.1 E-03
75-69-4	Trichlorofluoromethane	ND	ND	1.1 E-03
95-95-4	2,4,5-Trichlorophenol	ND	ND	1.7 E-02
88-06-2	2,4,6-Trichlorophenol	ND	ND	1.7 E-02
96-18-4	1,2,3-Trichloropropane	ND	ND	1.2 E-03
95-63-6	1,2,4-Trimethylbenzene	ND	ND	1.0 E-03
540-84-1	2,2,4-Trimethylpentane	ND	ND	9.5 E-04

TABLE A1 (cont.)

CASRN <sup>a</sup>	Compound	Emission Factor <sup>b,c</sup>		Minimum Detection Level mg/m <sup>3,e</sup>
		lb per item	lb per lb NEW <sup>d</sup>	
7440-62-2	Vanadium	ND	ND	4.0 E-04
108-05-4	Vinyl acetate	ND	ND	7.2 E-04
75-01-4	Vinyl chloride	ND	ND	5.2 E-04
75-35-4	Vinylidene chloride	ND	ND	8.1 E-04
106-42-3, 108-38-3	m-Xylene, p-Xylene	ND	ND	8.8 E-04
95-47-6	o-Xylene	ND	ND	8.8 E-04
Other Pollutants				
67-64-1	Acetone	3.5 E-08	1.3 E-05	--
74-86-2	Acetylene <sup>g</sup>	1.6 E-06	5.8 E-04	--
35572-78-2	2-Amino-4,6-dinitrotoluene	ND	ND	6.6 E-04
19406-51-0	4-Amino-2,6-dinitrotoluene	ND	ND	6.6 E-04
100-52-7	Benzaldehyde <sup>i</sup>	5.3 E-08	2.0 E-05	--
100-51-6	Benzyl alcohol	ND	ND	1.7 E-02
108-86-1	Bromobenzene	ND	ND	1.3 E-03
106-97-8	Butane	ND	ND	5.3 E-02
106-98-9	1-Butene	ND	ND	4.7 E-02
590-18-1	cis-Butene	ND	ND	4.7 E-02
624-64-6	trans-Butene	ND	ND	4.7 E-02
107-00-6	1-Butyne	ND	ND	4.5 E-02
503-17-3	2-Butyne	ND	ND	4.5 E-02
7440-44-0	Elemental carbon <sup>f</sup>	ND	ND	3.2 E-02
7440-44-0	Organic carbon <sup>f</sup>	1.7 E-06	6.2 E-04	--
7440-44-0	Total carbon <sup>f</sup>	1.7 E-06	6.2 E-04	--
39638-32-9	bis(2-Chloroisopropyl)ether	ND	ND	1.7 E-02
59-50-7	4-Chloro-3-methylphenol	ND	ND	1.7 E-02
124-48-1	Dibromochloromethane	ND	ND	1.7 E-03
156-59-2	cis-1,2-Dichloroethene	ND	ND	8.1 E-04
156-60-5	trans-1,2-Dichloroethene	ND	ND	8.1 E-04
10061-01-5	cis-1,3-Dichloropropene	ND	ND	9.2 E-04
84-66-2	Diethylphthalate	ND	ND	1.7 E-02
5779-94-2	2,5-Dimethylbenzaldehyde	ND	ND	7.6 E-03
117-84-0	Di-n-octylphthalate	ND	ND	1.7 E-02
74-84-0	Ethane <sup>f</sup>	7.3 E-07	2.7 E-04	--

TABLE A1 (cont.)

CASRN <sup>a</sup>	Compound	Emission Factor <sup>b,c</sup>		Minimum Detection Level mg/m <sup>3,e</sup>
		lb per item	lb per lb NEW <sup>d</sup>	
141-78-6	Ethyl acetate	ND	ND	7.3 E-04
97-63-2	Ethyl methacrylate	ND	ND	9.5 E-04
622-96-8	4-Ethyltoluene	ND	ND	1.0 E-03
142-82-5	n-Heptane	ND	ND	8.3 E-04
66-25-1	Hexaldehyde	ND	ND	7.6 E-03
591-78-6	2-Hexanone	ND	ND	2.1 E-03
2691-41-0	HMX	ND	ND	1.3 E-03
10035-10-6	Hydrogen bromide	ND	ND	1.2 E-01
95-13-6	Indene <sup>k</sup>	1.0 E-08	3.8 E-06	--
75-28-5	Isobutane	ND	ND	4.8 E-02
115-11-7	Isobutylene	ND	ND	4.7 E-02
590-86-3	Isovaleraldehyde	ND	ND	7.6 E-03
75-52-5	Methane, nitro- <sup>l</sup>	1.6 E-08	5.8 E-06	--
78-93-3	Methyl ethyl ketone <sup>g</sup>	ND	ND	1.5 E-03
98-83-9	alpha-Methylstyrene	ND	ND	9.8 E-04
479-45-8	Methyl-2,4,6-trinitrophenylnitramine	ND	ND	6.6 E-04
88-74-7	2-Nitroaniline	ND	ND	1.7 E-02
99-09-2	3-Nitroaniline	ND	ND	1.7 E-02
88-72-2	2-Nitrotoluene	ND	ND	6.6 E-04
99-08-1	3-Nitrotoluene	ND	ND	6.6 E-04
99-99-0	4-Nitrotoluene	ND	ND	6.6 E-04
301-02-0	9-Octadecenamide, (Z)- <sup>k</sup>	1.4 E-07	5.1 E-05	--
111-65-9	Octane	ND	ND	9.5 E-04
78-11-5	Pentaerythritol tetranitrate	ND	ND	1.3 E-03
109-66-0	Pentane	ND	ND	6.0 E-02
14797-73-0	Perchlorate	ND	ND	1.3 E-01
7664-38-2	Phosphoric acid	ND	ND	1.0 E-01
74-98-6	Propane	ND	ND	3.7 E-02
115-11-7	1-Propene, 2-methyl	ND	ND	4.7 E-02
74-99-7	Propyne	ND	ND	3.3 E-02
121-82-4	RDX	2.4 E-09	8.8 E-07	--
1334-78-7	o,m,p-Tolualdehyde	ND	ND	2.3 E-02
25323-89-1	Trichloroethane	ND	ND	9.9 E-04

TABLE A1 (cont.)

CASRN <sup>a</sup>	Compound	Emission Factor <sup>b,c</sup>		Minimum Detection Level mg/m <sup>3,e</sup>
		lb per item	lb per lb NEW <sup>d</sup>	
108-67-8	1,3,5-Trimethylbenzene	ND	ND	1.0 E-03
99-35-4	1,3,5-Trinitrobenzene	ND	ND	6.6 E-04
118-96-7	2,4,6-Trinitrotoluene	ND	ND	6.6 E-04
110-62-3	Valeraldehyde	ND	ND	7.6 E-03

<sup>a</sup> CASRN = Chemical Abstracts Service Registry Number.

<sup>b</sup> ND = nondetected.

<sup>c</sup> Emission factors rated C unless otherwise noted.

<sup>d</sup> NEW = Net explosive weight. The NEW for this compound is 2.70 E-03 pounds per item.

<sup>e</sup> Data provided for compounds that were not detected.

<sup>f</sup> Emission factor rated A because of correlation with emission factors for similar ordnance and number of test data points.

<sup>g</sup> Emission factor rated B because of correlation with emission factors for similar ordnance and number of test data points.

<sup>h</sup> Emission factor based upon C-rated test data, but because of correlation with emission factors for similar ordnance and number of data points the factor was upgraded from a D rating to a B rating.

<sup>i</sup> Emission factor rated D because the factor is based upon C-rated test data.

<sup>j</sup> Emission factor based upon C-rated test data, but because of correlation with emission factors for similar ordnance and number of data points the factor was upgraded from a D rating to a C rating.

<sup>k</sup> Emission factor rated D because the factor is for a tentatively identified compound.

<sup>l</sup> Emission factor was originally rated D because the factor is for a tentatively identified compound, but because of correlation with emission factors for similar ordnance and number of data points the factor was upgraded from a D rating to a C rating.



TABLE A2 COMPOUNDS ANALYZED AND EMISSION FACTORS DEVELOPED FOR  
DODIC A518, M962 .50 CALIBER SABOTED LIGHT ARMOR PENETRATOR-TRACER  
CARTRIDGE

CASRN <sup>a</sup>	Compound	Emission Factor <sup>b,c</sup>		Minimum Detection Level mg/m <sup>3,e</sup>
		lb per item	lb per lb NEW <sup>d</sup>	
Carbon Dioxide, Criteria Pollutants, Methane, and Total Suspended Particulate				
124-38-9	Carbon dioxide <sup>f</sup>	5.8 E-03	1.4 E-01	--
630-08-0	Carbon monoxide <sup>f</sup>	1.1 E-02	2.7 E-01	--
7439-92-1	Lead	1.7 E-04	4.1 E-03	--
74-82-8	Methane <sup>f</sup>	9.2 E-05	2.2 E-03	--
--	Oxides of nitrogen <sup>g</sup>	1.3 E-04	3.0 E-03	--
--	PM-2.5 <sup>g</sup>	3.4 E-04	8.2 E-03	--
--	PM-10 <sup>g</sup>	8.6 E-04	2.1 E-02	--
7446-09-5	Sulfur dioxide	ND	ND	2.7 E-01
12789-66-1	Total suspended particulate <sup>g</sup>	1.0 E-03	2.5 E-02	--
Hazardous Air Pollutants and Toxic Chemicals				
83-32-9	Acenaphthene <sup>f</sup>	ND	ND	1.7 E-02
208-96-8	Acenaphthylene <sup>g</sup>	4.0 E-08	9.9 E-07	--
75-07-0	Acetaldehyde <sup>f</sup>	1.5 E-07	3.6 E-06	--
75-05-8	Acetonitrile <sup>f</sup>	5.5 E-06	1.3 E-04	--
107-02-8	Acrolein <sup>g</sup>	ND	ND	7.5 E-03
107-13-1	Acrylonitrile <sup>f</sup>	1.1 E-07	2.6 E-06	--
107-05-1	Allyl chloride	ND	ND	1.6 E-03
7429-90-5	Aluminum <sup>g</sup>	4.3 E-05	1.0 E-03	--
7664-41-7	Ammonia <sup>f</sup>	3.4 E-04	8.3 E-03	--
120-12-7	Anthracene <sup>g</sup>	7.9 E-09	1.9 E-07	--
7440-36-0	Antimony <sup>g</sup>	5.3 E-06	1.3 E-04	--
7440-38-2	Arsenic <sup>g</sup>	1.6 E-07	3.9 E-06	--
7440-39-3	Barium <sup>g</sup>	4.8 E-05	1.2 E-03	--
71-43-2	Benzene <sup>g</sup>	2.5 E-05	6.1 E-04	--
56-55-3	Benzo[a]anthracene <sup>g</sup>	1.0 E-08	2.6 E-07	--
205-99-2	Benzo[b]fluoranthene <sup>g</sup>	3.0 E-08	7.2 E-07	--
207-08-9	Benzo[k]fluoranthene <sup>f</sup>	6.7 E-09	1.6 E-07	--
191-24-2	Benzo[g,h,i]perylene <sup>f</sup>	5.5 E-08	1.3 E-06	--
50-32-8	Benzo[a]pyrene <sup>f</sup>	1.3 E-08	3.2 E-07	--
192-97-2	Benzo[e]pyrene <sup>g</sup>	2.7 E-08	6.7 E-07	--
7440-41-7	Beryllium <sup>h</sup>	3.8 E-08	9.4 E-07	--

TABLE A2 (cont.)

CASRN <sup>a</sup>	Compound	Emission Factor <sup>b,c</sup>		Minimum Detection Level mg/m <sup>3,e</sup>
		lb per item	lb per lb NEW <sup>d</sup>	
75-25-2	Bromoform	ND	ND	2.1 E-03
74-83-9	Bromomethane	ND	ND	7.9 E-04
101-55-3	4-Bromophenylphenylether	ND	ND	1.7 E-02
106-99-0	1,3-Butadiene <sup>f</sup>	ND	ND	4.5 E-02
75-65-0	t-Butyl alcohol	ND	ND	6.2 E-04
85-68-7	Butylbenzylphthalate	ND	ND	1.7 E-02
123-72-8	Butyraldehyde	ND	ND	7.5 E-03
7440-43-9	Cadmium	3.4 E-07	8.2 E-06	--
75-15-0	Carbon disulfide <sup>g</sup>	ND	ND	1.6 E-03
56-23-5	Carbon tetrachloride	ND	ND	1.3 E-03
106-47-8	4-Chloroaniline	ND	ND	1.7 E-02
108-90-7	Chlorobenzene	ND	ND	9.4 E-04
75-45-6	Chlorodifluoromethane	ND	ND	3.6 E-03
75-00-3	Chloroethane	ND	ND	5.4 E-04
111-91-1	bis(2-Chloroethoxy)methane	ND	ND	1.7 E-02
111-44-4	bis(2-Chloroethyl)ether	ND	ND	1.7 E-02
67-66-3	Chloroform	ND	ND	9.9 E-04
74-87-3	Chloromethane <sup>f</sup>	ND	ND	4.2 E-04
91-58-7	2-Chloronaphthalene	ND	ND	1.7 E-02
95-57-8	2-Chlorophenol	ND	ND	1.7 E-02
7005-72-3	4-chlorophenyl-phenylether	ND	ND	1.7 E-02
7440-47-3	Chromium	1.1 E-05	2.7 E-04	--
18540-29-9	Hexavalent chromium <sup>h</sup>	3.8 E-03	9.2 E-02	--
218-01-9	Chrysene <sup>g</sup>	2.4 E-08	5.9 E-07	--
7440-48-4	Cobalt <sup>h</sup>	8.1 E-08	2.0 E-06	--
7440-50-8	Copper <sup>g</sup>	1.1 E-05	2.7 E-04	--
106-44-5	p-Cresol	ND	ND	1.7 E-02
4170-30-3	Crotonaldehyde	ND	ND	7.5 E-03
98-82-8	Cumene	ND	ND	1.0 E-03
57-12-5	Particulate cyanide <sup>f</sup>	ND	ND	1.4 E-02
53-70-3	Dibenz[a,h]anthracene <sup>f</sup>	2.1 E-09	5.2 E-08	--
132-64-9	Dibenzofuran	ND	ND	1.7 E-02
106-93-4	1,2-Dibromoethane	ND	ND	1.6 E-03
84-74-2	Dibutyl phthalate	ND	ND	1.6 E-03
95-50-1	1,2-Dichlorobenzene	ND	ND	3.1 E-03

TABLE A2 (cont.)

CASRN <sup>a</sup>	Compound	Emission Factor <sup>b,c</sup>		Minimum Detection Level mg/m <sup>3,e</sup>
		lb per item	lb per lb NEW <sup>d</sup>	
541-73-1	1,3-Dichlorobenzene	ND	ND	3.1 E-03
106-46-7	1,4-Dichlorobenzene	ND	ND	3.1 E-03
75-27-4	Dichlorobromomethane	ND	ND	1.4 E-03
75-71-8	Dichlorodifluoromethane	ND	ND	1.0 E-03
75-34-3	1,1-Dichloroethane	ND	ND	8.2 E-04
107-06-2	1,2-Dichloroethane <sup>f</sup>	4.7 E-07	1.2 E-05	--
75-43-4	Dichlorofluoromethane	ND	ND	8.6 E-04
120-83-2	2,4-Dichlorophenol	ND	ND	1.7 E-02
78-87-5	1,2-Dichloropropane	ND	ND	9.4 E-04
10061-02-6	trans-1,3-Dichloropropene	ND	ND	9.2 E-04
76-14-2	Dichlorotetrafluoroethane	ND	ND	1.4 E-03
105-67-9	2,4-Dimethylphenol	ND	ND	1.7 E-02
131-11-3	Dimethyl phthalate	ND	ND	1.7 E-02
99-65-0	1,3-Dinitrobenzene	ND	ND	6.6 E-04
534-52-1	4,6-Dinitro-2-methylphenol	ND	ND	1.7 E-02
51-28-5	2,4-Dinitrophenol	ND	ND	1.7 E-02
121-14-2	2,4-Dinitrotoluene	ND	ND	6.6 E-04
606-20-2	2,6-Dinitrotoluene	ND	ND	6.6 E-04
123-91-1	1,4-Dioxane	ND	ND	7.3 E-04
--	Total dioxin/furan compounds <sup>g</sup>	4.4 E-12	1.1 E-10	--
122-39-4	Diphenyl amine	ND	ND	1.3 E-03
140-88-5	Ethyl acrylate	ND	ND	8.3 E-04
100-41-4	Ethylbenzene <sup>g</sup>	ND	ND	8.8 E-04
74-85-1	Ethylene <sup>g</sup>	1.8 E-06	4.5 E-05	--
117-81-7	bis(2-Ethylhexyl)phthalate	ND	ND	1.6 E-03
206-44-0	Fluoranthene <sup>g</sup>	6.1 E-08	1.5 E-06	--
86-73-7	Fluorene <sup>g</sup>	2.6 E-08	6.3 E-07	--
50-00-0	Formaldehyde	7.0 E-07	1.7 E-05	--
76-13-1	Freon 113	ND	ND	3.9 E-03
118-74-1	Hexachlorobenzene	ND	ND	1.7 E-02
87-68-3	Hexachlorobutadiene	ND	ND	5.4 E-03
77-47-4	Hexachlorocyclopentadiene	ND	ND	1.7 E-02
67-72-1	Hexachloroethane	ND	ND	2.0 E-03
110-54-3	Hexane <sup>g</sup>	ND	ND	7.2 E-02
7647-01-0	Hydrochloric acid <sup>g</sup>	1.6 E-06	3.8 E-05	--

TABLE A2 (cont.)

CASRN <sup>a</sup>	Compound	Emission Factor <sup>b,c</sup>		Minimum Detection Level mg/m <sup>3,e</sup>
		lb per item	lb per lb NEW <sup>d</sup>	
74-90-8	Hydrogen cyanide <sup>g</sup>	9.9 E-05	2.4 E-03	--
7664-39-3	Hydrogen fluoride	ND	ND	1.9 E-01
193-39-5	Indeno[1,2,3-cd]pyrene <sup>f</sup>	2.0 E-08	4.8 E-07	--
78-59-1	Isophorone	ND	ND	1.7 E-02
7439-96-5	Manganese	3.6 E-07	8.8 E-06	--
96-33-3	Methyl acrylate	ND	ND	7.2 E-04
74-95-3	Methylene bromide	ND	ND	1.4 E-03
75-09-2	Methylene chloride <sup>g</sup>	2.1 E-07	5.2 E-06	--
74-88-4	Methyl iodide	ND	ND	1.2 E-03
108-10-1	Methyl isobutyl ketone	ND	ND	2.1 E-03
80-62-6	Methyl methacrylate	ND	ND	8.3 E-04
91-57-6	2-Methylnaphthalene	ND	ND	1.7 E-02
95-48-7	2-Methylphenol	ND	ND	1.7 E-02
1634-04-4	Methyl tert-butyl ether	ND	ND	7.3 E-04
91-20-3	Naphthalene <sup>f</sup>	4.2 E-07	1.0 E-05	--
7440-02-0	Nickel	2.8 E-06	6.9 E-05	--
7697-37-2	Nitric acid	ND	ND	1.1 E-01
100-01-6	4-Nitroaniline	ND	ND	1.7 E-02
98-95-3	Nitrobenzene	ND	ND	6.6 E-04
55-63-0	Nitroglycerin	4.3 E-08	1.0 E-06	--
88-75-5	2-Nitrophenol	ND	ND	1.7 E-02
100-02-7	4-Nitrophenol	ND	ND	1.7 E-02
62-75-9	n-Nitrosodimethylamine	ND	ND	1.7 E-02
86-30-6	n-Nitrosodiphenylamine	ND	ND	1.7 E-02
621-64-7	n-Nitroso-di-n-propylamine	ND	ND	1.7 E-02
3268-87-9	1,2,3,4,6,7,8,9-Octachlorodibenzo-p-dioxin	4.4 E-12	1.1 E-10	--
40321-76-4	1,2,3,7,8-Pentachlorodibenzo-p-dioxin	ND	ND	4.1 E-09
57117-41-6	1,2,3,7,8-Pentachlorodibenzofuran <sup>g</sup>	ND	ND	2.3 E-09
57117-31-4	2,3,4,7,8-Pentachlorodibenzofuran	ND	ND	2.2 E-09
87-86-5	Pentachlorophenol	ND	ND	1.7 E-02
85-01-8	Phenanthrene <sup>g</sup>	7.0 E-08	1.7 E-06	--
108-95-2	Phenol	1.5 E-07	3.7 E-06	--

TABLE A2 (cont.)

CASRN <sup>a</sup>	Compound	Emission Factor <sup>b,c</sup>		Minimum Detection Level mg/m <sup>3,e</sup>
		lb per item	lb per lb NEW <sup>d</sup>	
123-38-6	Propionaldehyde <sup>g</sup>	ND	ND	7.5 E-03
115-07-1	Propylene <sup>f</sup>	ND	ND	3.5 E-02
129-00-0	Pyrene <sup>g</sup>	1.1 E-07	2.6 E-06	--
7782-49-2	Selenium <sup>h</sup>	5.1 E-08	1.2 E-06	--
7440-22-4	Silver <sup>h</sup>	3.2 E-08	7.8 E-07	--
100-42-5	Styrene <sup>f</sup>	2.1 E-07	5.1 E-06	--
7664-93-9	Sulfuric acid	ND	ND	1.2 E-01
1746-01-6	2,3,7,8-Tetrachlorodibenzo-p-dioxin	ND	ND	1.9 E-09
51207-31-9	2,3,7,8-Tetrachlorodibenzofuran <sup>g</sup>	ND	ND	1.5 E-09
630-20-6	1,1,1,2-Tetrachloroethane	ND	ND	1.4 E-03
79-34-5	1,1,2,2-Tetrachloroethane	ND	ND	1.4 E-03
127-18-4	Tetrachloroethylene	ND	ND	1.4 E-03
7440-28-0	Thallium	1.8 E-07	4.4 E-06	--
108-88-3	Toluene <sup>g</sup>	1.1 E-06	2.8 E-05	--
120-82-1	1,2,4-Trichlorobenzene	ND	ND	7.5 E-03
71-55-6	1,1,1-Trichloroethane <sup>g</sup>	ND	ND	1.1 E-03
79-00-5	1,1,2-Trichloroethane	ND	ND	1.1 E-03
75-69-4	Trichlorofluoromethane	ND	ND	1.1 E-03
95-95-4	2,4,5-Trichlorophenol	ND	ND	1.7 E-02
88-06-2	2,4,6-Trichlorophenol	ND	ND	1.7 E-02
96-18-4	1,2,3-Trichloropropane	ND	ND	1.2 E-03
95-63-6	1,2,4-Trimethylbenzene	ND	ND	1.0 E-03
540-84-1	2,2,4-Trimethylpentane	ND	ND	9.5 E-04
7440-62-2	Vanadium	ND	ND	4.0 E-04
108-05-4	Vinyl acetate	ND	ND	7.2 E-04
75-01-4	Vinyl chloride	ND	ND	5.2 E-04
75-35-4	Vinylidene chloride	ND	ND	8.1 E-04
106-42-3, 108-38-3	m-Xylene, p-Xylene	ND	ND	8.8 E-04
95-47-6	o-Xylene	ND	ND	8.8 E-04
7440-66-6	Zinc <sup>f</sup>	6.6 E-06	1.6 E-04	--
Other Pollutants				
67-64-1	Acetone	2.0 E-07	4.8 E-06	--
74-86-2	Acetylene <sup>g</sup>	3.9 E-07	9.4 E-06	--
35572-78-2	2-Amino-4,6-dinitrotoluene	ND	ND	6.6 E-04

TABLE A2 (cont.)

CASRN <sup>a</sup>	Compound	Emission Factor <sup>b,c</sup>		Minimum Detection Level mg/m <sup>3,e</sup>
		lb per item	lb per lb NEW <sup>d</sup>	
19406-51-0	4-Amino-2,6-dinitrotoluene	ND	ND	6.6 E-04
100-52-7	Benzaldehyde	3.5 E-08	8.5 E-07	--
100-47-0	Benzonitrile <sup>j</sup>	2.0 E-07	4.9 E-06	--
100-51-6	Benzyl alcohol	ND	ND	1.7 E-02
108-86-1	Bromobenzene	ND	ND	1.3 E-03
106-97-8	Butane	ND	ND	5.3 E-02
106-98-9	1-Butene	ND	ND	4.7 E-02
590-18-1	cis-Butene	ND	ND	4.7 E-02
624-64-6	trans-Butene	ND	ND	4.7 E-02
107-00-6	1-Butyne	ND	ND	4.5 E-02
503-17-3	2-Butyne	ND	ND	4.5 E-02
7440-70-2	Calcium <sup>g</sup>	9.8 E-06	2.4 E-04	--
7440-44-0	Elemental carbon <sup>f</sup>	4.0 E-05	9.8 E-04	--
7440-44-0	Organic carbon <sup>f</sup>	4.8 E-05	1.2 E-03	--
7440-44-0	Total carbon <sup>f</sup>	8.9 E-05	2.2 E-03	--
39638-32-9	bis(2-Chloroisopropyl)ether	ND	ND	1.7 E-02
59-50-7	4-Chloro-3-methylphenol	ND	ND	1.7 E-02
124-48-1	Dibromochloromethane	ND	ND	1.7 E-03
156-59-2	cis-1,2-Dichloroethene	ND	ND	8.1 E-04
156-60-5	trans-1,2-Dichloroethene	ND	ND	8.1 E-04
10061-01-5	cis-1,3-Dichloropropene	ND	ND	9.2 E-04
84-66-2	Diethylphthalate	ND	ND	1.7 E-02
5779-94-2	2,5-Dimethylbenzaldehyde	ND	ND	7.5 E-03
117-84-0	Di-n-octylphthalate	ND	ND	1.7 E-02
74-84-0	Ethane <sup>f</sup>	8.5 E-07	2.1 E-05	--
141-78-6	Ethyl acetate	ND	ND	7.3 E-04
97-63-2	Ethyl methacrylate	ND	ND	9.5 E-04
622-96-8	4-Ethyltoluene	ND	ND	1.0 E-03
142-82-5	n-Heptane	ND	ND	8.3 E-04
66-25-1	Hexaldehyde	ND	ND	7.5 E-03
591-78-6	2-Hexanone	ND	ND	2.1 E-03
2691-41-0	HMX	3.2 E-07	7.7 E-06	--
10035-10-6	Hydrogen bromide	ND	ND	1.2 E-01
75-28-5	Isobutane	ND	ND	4.8 E-02
115-11-7	Isobutylene	ND	ND	4.7 E-02

TABLE A2 (cont.)

CASRN <sup>a</sup>	Compound	Emission Factor <sup>b,c</sup>		Minimum Detection Level mg/m <sup>3,e</sup>
		lb per item	lb per lb NEW <sup>d</sup>	
590-86-3	Isovaleraldehyde	ND	ND	7.5 E-03
7439-95-4	Magnesium	4.3 E-06	1.0 E-04	--
78-93-3	Methyl ethyl ketone <sup>g</sup>	ND	ND	1.5 E-03
98-83-9	alpha-Methylstyrene	ND	ND	9.8 E-04
479-45-8	Methyl-2,4,6-trinitrophenylnitramine	ND	ND	6.6 E-04
88-74-7	2-Nitroaniline	ND	ND	1.7 E-02
99-09-2	3-Nitroaniline	ND	ND	1.7 E-02
88-72-2	2-Nitrotoluene	ND	ND	6.6 E-04
99-08-1	3-Nitrotoluene	ND	ND	6.6 E-04
99-99-0	4-Nitrotoluene	ND	ND	6.6 E-04
111-65-9	Octane	ND	ND	9.5 E-04
78-11-5	Pentaerythritol tetranitrate	ND	ND	1.3 E-03
109-66-0	Pentane	ND	ND	6.0 E-02
14797-73-0	Perchlorate	ND	ND	7.2 E-02
7664-38-2	Phosphoric acid	ND	ND	1.0 E-01
74-98-6	Propane	ND	ND	3.7 E-02
115-11-7	1-Propene, 2-methyl	ND	ND	4.7 E-02
74-99-7	Propyne	ND	ND	3.3 E-02
121-82-4	RDX	1.0 E-05	2.5 E-04	--
1334-78-7	o,m,p-Tolualdehyde	ND	ND	2.3 E-02
25323-89-1	Trichloroethane	ND	ND	9.9 E-04
108-67-8	1,3,5-Trimethylbenzene	ND	ND	1.0 E-03
99-35-4	1,3,5-Trinitrobenzene	ND	ND	6.6 E-04
118-96-7	2,4,6-Trinitrotoluene	ND	ND	6.6 E-04
110-62-3	Valeraldehyde	ND	ND	7.5 E-03

TABLE A2 (cont.)

- <sup>a</sup> CASRN = Chemical Abstracts Service Registry Number.
- <sup>b</sup> ND = nondetected.
- <sup>c</sup> Emission factors rated C unless otherwise noted.
- <sup>d</sup> NEW = Net explosive weight. The NEW for this compound is 4.11 E-02 pounds per item.
- <sup>e</sup> Data provided for compounds that were not detected.
- <sup>f</sup> Emission factor rated A because of correlation with emission factors for similar ordnance and number of test data points.
- <sup>g</sup> Emission factor rated B because of correlation with emission factors for similar ordnance and number of test data points.
- <sup>h</sup> Emission factor rated D because the factor is based upon C-rated test data.
- <sup>i</sup> Emission factor based upon C-rated test data, but because of correlation with emission factors for similar ordnance and number of data points the factor was upgraded from a D rating to a C rating.
- <sup>j</sup> Emission factor rated D because the factor is for a tentatively identified compound.

DRAFT



TABLE A3 COMPOUNDS ANALYZED AND EMISSION FACTORS DEVELOPED FOR  
DODIC B627, M83A3 60-MM ILLUMINATING MORTAR CARTRIDGE  
(PROPELLING CHARGE ONLY)

CASRN <sup>a</sup>	Compound	Emission Factor <sup>b,c</sup>		Minimum Detection Level mg/m <sup>3,e</sup>
		lb per item	lb per lb NEW <sup>d</sup>	
Carbon Dioxide, Criteria Pollutants, Methane, and Total Suspended Particulate				
124-38-9	Carbon dioxide <sup>f</sup>	2.1 E-03	9.6 E-02	--
630-08-0	Carbon monoxide <sup>f</sup>	3.4 E-03	1.5 E-01	--
7439-92-1	Lead <sup>g</sup>	1.8 E-05	8.0 E-04	--
74-82-8	Methane <sup>f</sup>	4.0 E-05	1.8 E-03	--
--	Oxides of nitrogen <sup>f</sup>	1.0 E-04	4.5 E-03	--
--	PM-2.5 <sup>g</sup>	3.1 E-04	1.4 E-02	--
--	PM-10 <sup>g</sup>	4.6 E-04	2.1 E-02	--
7446-09-5	Sulfur dioxide	ND	ND	2.7 E-01
12789-66-1	Total suspended particulate <sup>g</sup>	4.8 E-04	2.2 E-02	--
Hazardous Air Pollutants and Toxic Chemicals				
83-32-9	Acenaphthene <sup>g</sup>	5.6 E-09	2.6 E-07	--
208-96-8	Acenaphthylene <sup>g</sup>	2.1 E-07	9.4 E-06	--
75-07-0	Acetaldehyde <sup>g</sup>	3.5 E-06	1.6 E-04	--
75-05-8	Acetonitrile	ND	ND	8.5 E-04
107-02-8	Acrolein	ND	ND	7.3 E-03
107-13-1	Acrylonitrile <sup>g</sup>	2.4 E-07	1.1 E-05	--
107-05-1	Allyl chloride	ND	ND	1.6 E-03
7429-90-5	Aluminum <sup>g</sup>	5.7 E-06	2.6 E-04	--
7664-41-7	Ammonia <sup>f</sup>	ND	ND	3.5 E-01
120-12-7	Anthracene <sup>g</sup>	5.7 E-09	2.6 E-07	--
7440-36-0	Antimony	1.3 E-06	5.9 E-05	--
7440-38-2	Arsenic	ND	ND	4.0 E-04
7440-39-3	Barium	5.1 E-06	2.3 E-04	--
71-43-2	Benzene	7.0 E-05	3.2 E-03	--
56-55-3	Benzo[a]anthracene <sup>g</sup>	4.4 E-09	2.0 E-07	--
205-99-2	Benzo[b]fluoranthene <sup>g</sup>	1.5 E-08	6.6 E-07	--
207-08-9	Benzo[k]fluoranthene <sup>g</sup>	7.0 E-09	3.2 E-07	--
191-24-2	Benzo[g,h,i]perylene <sup>g</sup>	6.4 E-09	2.9 E-07	--
50-32-8	Benzo[a]pyrene <sup>g</sup>	1.0 E-08	4.6 E-07	--
192-97-2	Benzo[e]pyrene <sup>g</sup>	9.5 E-09	4.3 E-07	--
7440-41-7	Beryllium	ND	ND	4.0 E-04
75-25-2	Bromoform	ND	ND	2.1 E-03

TABLE A3 (cont.)

CASRN <sup>a</sup>	Compound	Emission Factor <sup>b,c</sup>		Minimum Detection Level mg/m <sup>3,e</sup>
		lb per item	lb per lb NEW <sup>d</sup>	
74-83-9	Bromomethane	ND	ND	7.9 E-04
101-55-3	4-Bromophenylphenylether	ND	ND	1.7 E-02
106-99-0	1,3-Butadiene	1.8 E-06	8.3 E-05	--
75-65-0	t-Butyl alcohol	ND	ND	6.2 E-04
85-68-7	Butylbenzylphthalate	ND	ND	1.7 E-02
123-72-8	Butyraldehyde	ND	ND	7.3 E-03
7440-43-9	Cadmium	5.5 E-08	2.5 E-06	--
75-15-0	Carbon disulfide	ND	ND	1.6 E-03
56-23-5	Carbon tetrachloride	ND	ND	1.3 E-03
106-47-8	4-Chloroaniline	ND	ND	1.7 E-02
108-90-7	Chlorobenzene	ND	ND	9.4 E-04
75-45-6	Chlorodifluoromethane	ND	ND	3.6 E-03
75-00-3	Chloroethane	ND	ND	5.4 E-04
111-91-1	bis(2-Chloroethoxy)methane	ND	ND	1.7 E-02
111-44-4	bis(2-Chloroethyl)ether	ND	ND	1.7 E-02
67-66-3	Chloroform	ND	ND	9.9 E-04
74-87-3	Chloromethane	ND	ND	4.2 E-04
91-58-7	2-Chloronaphthalene	ND	ND	1.7 E-02
95-57-8	2-Chlorophenol	ND	ND	1.7 E-02
7005-72-3	4-Chlorophenyl-phenylether	ND	ND	1.7 E-02
7440-47-3	Chromium	9.1 E-07	4.1 E-05	--
18540-29-9	Hexavalent chromium <sup>i</sup>	3.3 E-04	1.5 E-02	--
218-01-9	Chrysene	8.2 E-09	3.7 E-07	--
7440-48-4	Cobalt	ND	ND	4.0 E-04
7440-50-8	Copper <sup>g</sup>	1.2 E-06	5.5 E-05	--
106-44-5	p-Cresol	ND	ND	1.7 E-02
4170-30-3	Crotonaldehyde	ND	ND	7.3 E-03
98-82-8	Cumene	ND	ND	1.0 E-03
57-12-5	Particulate cyanide	ND	ND	1.4 E-02
53-70-3	Dibenz[a,h]anthracene <sup>g</sup>	1.2 E-09	5.2 E-08	--
132-64-9	Dibenzofuran	ND	ND	1.7 E-02
106-93-4	1,2-Dibromoethane	ND	ND	1.6 E-03
84-74-2	Dibutyl phthalate	ND	ND	1.3 E-03
95-50-1	1,2-Dichlorobenzene	ND	ND	3.1 E-03
541-73-1	1,3-Dichlorobenzene	ND	ND	3.1 E-03

TABLE A3 (cont.)

CASRN <sup>a</sup>	Compound	Emission Factor <sup>b,c</sup>		Minimum Detection Level mg/m <sup>3,e</sup>
		lb per item	lb per lb NEW <sup>d</sup>	
106-46-7	1,4-Dichlorobenzene	ND	ND	3.1 E-03
75-27-4	Dichlorobromomethane	ND	ND	1.4 E-03
75-71-8	Dichlorodifluoromethane <sup>g</sup>	ND	ND	1.0 E-03
75-34-3	1,1-Dichloroethane	ND	ND	8.2 E-04
107-06-2	1,2-Dichloroethane	2.5 E-06	1.1 E-04	--
75-43-4	Dichlorofluoromethane	ND	ND	8.6 E-04
120-83-2	2,4-Dichlorophenol	ND	ND	1.7 E-02
78-87-5	1,2-Dichloropropane	ND	ND	9.4 E-04
10061-02-6	trans-1,3-Dichloropropene	ND	ND	9.2 E-04
76-14-2	Dichlorotetrafluoroethane	ND	ND	1.4 E-03
105-67-9	2,4-Dimethylphenol	ND	ND	1.7 E-02
131-11-3	Dimethyl phthalate	ND	ND	1.7 E-02
99-65-0	1,3-Dinitrobenzene	ND	ND	6.5 E-04
534-52-1	4,6-Dinitro-2-methylphenol	ND	ND	1.7 E-02
51-28-5	2,4-Dinitrophenol	ND	ND	1.7 E-02
121-14-2	2,4-Dinitrotoluene	ND	ND	6.5 E-04
606-20-2	2,6-Dinitrotoluene	ND	ND	6.5 E-04
123-91-1	1,4-Dioxane	ND	ND	7.3 E-04
--	Total dioxin/furan compounds	1.7 E-12	7.8 E-11	--
122-39-4	Diphenyl amine	ND	ND	1.3 E-03
140-88-5	Ethyl acrylate	ND	ND	8.3 E-04
100-41-4	Ethylbenzene	6.4 E-07	2.9 E-05	--
74-85-1	Ethylene <sup>g</sup>	3.7 E-05	1.7 E-03	--
117-81-7	bis(2-Ethylhexyl)phthalate	ND	ND	1.3 E-03
206-44-0	Fluoranthene <sup>g</sup>	4.3 E-09	1.9 E-07	--
86-73-7	Fluorene <sup>g</sup>	5.5 E-08	2.5 E-06	--
50-00-0	Formaldehyde <sup>g</sup>	8.7 E-06	4.0 E-04	--
76-13-1	Freon 113 <sup>g</sup>	ND	ND	3.9 E-03
35822-46-9	1,2,3,4,6,7,8-Heptachlorodibenzo-p-dioxin	1.7 E-12	7.8 E-11	--
118-74-1	Hexachlorobenzene	ND	ND	1.7 E-02
87-68-3	Hexachlorobutadiene	ND	ND	5.4 E-03
77-47-4	Hexachlorocyclopentadiene	ND	ND	1.7 E-02
67-72-1	Hexachloroethane	ND	ND	2.0 E-03
110-54-3	Hexane	ND	ND	7.2 E-02

TABLE A3 (cont.)

CASRN <sup>a</sup>	Compound	Emission Factor <sup>b,c</sup>		Minimum Detection Level mg/m <sup>3,e</sup>
		lb per item	lb per lb NEW <sup>d</sup>	
7647-01-0	Hydrochloric acid	ND	ND	9.0 E-02
74-90-8	Hydrogen cyanide <sup>g</sup>	1.6 E-06	7.2 E-05	--
7664-39-3	Hydrogen fluoride	ND	ND	1.8 E-01
193-39-5	Indeno[1,2,3-cd]pyrene <sup>f</sup>	7.5 E-09	3.4 E-07	--
78-59-1	Isophorone	ND	ND	1.7 E-02
7439-96-5	Manganese <sup>f</sup>	1.3 E-07	5.8 E-06	--
96-33-3	Methyl acrylate	ND	ND	7.2 E-04
74-95-3	Methylene bromide	ND	ND	1.4 E-03
75-09-2	Methylene chloride <sup>g</sup>	2.1 E-05	9.4 E-04	--
74-88-4	Methyl iodide	ND	ND	1.2 E-03
108-10-1	Methyl isobutyl ketone	ND	ND	2.1 E-03
80-62-6	Methyl methacrylate	ND	ND	8.3 E-04
91-57-6	2-Methylnaphthalene	ND	ND	1.7 E-02
95-48-7	2-Methylphenol	ND	ND	1.7 E-02
1634-04-4	Methyl tert-butyl ether	ND	ND	7.3 E-04
91-20-3	Naphthalene <sup>g</sup>	1.8 E-06	8.2 E-05	--
7440-02-0	Nickel	2.2 E-07	9.9 E-06	--
7697-37-2	Nitric acid <sup>g</sup>	ND	ND	1.0 E-01
100-01-6	4-Nitroaniline	ND	ND	1.7 E-02
98-95-3	Nitrobenzene	ND	ND	6.5 E-04
55-63-0	Nitroglycerin	2.0 E-07	9.2 E-06	--
88-75-5	2-Nitrophenol	ND	ND	1.7 E-02
100-02-7	4-Nitrophenol	ND	ND	1.7 E-02
62-75-9	n-Nitrosodimethylamine	ND	ND	1.7 E-02
86-30-6	n-Nitrosodiphenylamine	ND	ND	1.7 E-02
621-64-7	n-Nitroso-di-n-propylamine	ND	ND	1.7 E-02
40321-76-4	1,2,3,7,8-Pentachlorodibenzo-p-dioxin	0	0	--
57117-41-6	1,2,3,7,8-Pentachlorodibenzofuran	0	0	--
87-86-5	Pentachlorophenol	ND	ND	1.7 E-02
85-01-8	Phenanthrene <sup>g</sup>	3.3 E-08	1.5 E-06	--
108-95-2	Phenol <sup>g</sup>	ND	ND	1.7 E-02
123-38-6	Propionaldehyde	ND	ND	7.3 E-03
115-07-1	Propylene	5.4 E-06	2.4 E-04	--
129-00-0	Pyrene <sup>g</sup>	1.6 E-11	7.3 E-10	--

TABLE A3 (cont.)

CASRN <sup>a</sup>	Compound	Emission Factor <sup>b,c</sup>		Minimum Detection Level mg/m <sup>3,e</sup>
		lb per item	lb per lb NEW <sup>d</sup>	
7782-49-2	Selenium	ND	ND	4.0 E-04
7440-22-4	Silver	ND	ND	4.0 E-04
100-42-5	Styrene	2.8 E-05	1.3 E-03	--
7664-93-9	Sulfuric acid <sup>g</sup>	ND	ND	1.2 E-01
1746-01-6	2,3,7,8-Tetrachlorodibenzo-p-dioxin <sup>g</sup>	ND	ND	1.8 E-09
51207-31-9	2,3,7,8-Tetrachlorodibenzofuran	ND	ND	1.5 E-09
630-20-6	1,1,1,2-Tetrachloroethane	ND	ND	1.4 E-03
79-34-5	1,1,2,2-Tetrachloroethane	ND	ND	1.4 E-03
127-18-4	Tetrachloroethylene	ND	ND	1.4 E-03
7440-28-0	Thallium	ND	ND	4.0 E-04
108-88-3	Toluene	8.3 E-06	3.8 E-04	--
120-82-1	1,2,4-Trichlorobenzene	ND	ND	7.5 E-03
71-55-6	1,1,1-Trichloroethane	ND	ND	1.1 E-03
79-00-5	1,1,2-Trichloroethane	ND	ND	1.1 E-03
75-69-4	Trichlorofluoromethane	ND	ND	1.1 E-03
95-95-4	2,4,5-Trichlorophenol	ND	ND	1.7 E-02
88-06-2	2,4,6-Trichlorophenol	ND	ND	1.7 E-02
96-18-4	1,2,3-Trichloropropane	ND	ND	1.2 E-03
95-63-6	1,2,4-Trimethylbenzene	ND	ND	1.0 E-03
540-84-1	2,2,4-Trimethylpentane	ND	ND	9.5 E-04
7440-62-2	Vanadium	ND	ND	4.0 E-04
108-05-4	Vinyl acetate	ND	ND	7.2 E-04
75-01-4	Vinyl chloride	ND	ND	5.2 E-04
75-35-4	Vinylidene chloride <sup>g</sup>	ND	ND	8.1 E-04
106-42-3, 108-38-3	m-Xylene, p-Xylene <sup>g</sup>	2.4 E-07	1.1 E-05	--
95-47-6	o-Xylene <sup>h</sup>	8.8 E-08	4.0 E-06	--
7440-66-6	Zinc	1.9 E-06	8.8 E-05	--
Other Pollutants				
67-64-1	Acetone	5.8 E-07	2.6 E-05	--
74-86-2	Acetylene <sup>g</sup>	2.6 E-05	1.2 E-03	--
35572-78-2	2-Amino-4,6-dinitrotoluene	ND	ND	6.5 E-04
19406-51-0	4-Amino-2,6-dinitrotoluene	ND	ND	6.5 E-04
100-52-7	Benzaldehyde	2.1 E-07	9.4 E-06	--

TABLE A3 (cont.)

CASRN <sup>a</sup>	Compound	Emission Factor <sup>b,c</sup>		Minimum Detection Level mg/m <sup>3,e</sup>
		lb per item	lb per lb NEW <sup>d</sup>	
100-51-6	Benzyl alcohol	ND	ND	1.7 E-02
108-86-1	Bromobenzene	ND	ND	1.3 E-03
106-97-8	Butane	ND	ND	5.3 E-02
106-98-9	1-Butene	ND	ND	4.7 E-02
590-18-1	cis-Butene	ND	ND	4.7 E-02
624-64-6	trans-Butene	ND	ND	4.7 E-02
107-00-6	1-Butyne	ND	ND	4.5 E-02
503-17-3	2-Butyne	ND	ND	4.5 E-02
7440-44-0	Elemental carbon <sup>g</sup>	2.5 E-06	1.2 E-04	--
7440-44-0	Organic carbon <sup>f</sup>	3.3 E-05	1.5 E-03	--
7440-44-0	Total carbon <sup>f</sup>	3.6 E-05	1.6 E-03	--
39638-32-9	bis(2-Chloroisopropyl)ether	ND	ND	1.7 E-02
59-50-7	4-Chloro-3-methylphenol	ND	ND	1.7 E-02
124-48-1	Dibromochloromethane	ND	ND	1.7 E-03
156-59-2	cis-1,2-Dichloroethene	ND	ND	8.1 E-04
156-60-5	trans-1,2-Dichloroethene	ND	ND	8.1 E-04
10061-01-5	cis-1,3-Dichloropropene	ND	ND	9.2 E-04
84-66-2	Diethylphthalate	ND	ND	1.7 E-02
5779-94-2	2,5-Dimethylbenzaldehyde	ND	ND	7.3 E-03
117-84-0	Di-n-octylphthalate	ND	ND	1.7 E-02
74-84-0	Ethane <sup>g</sup>	2.0 E-06	9.2 E-05	--
141-78-6	Ethyl acetate	ND	ND	7.3 E-04
97-63-2	Ethyl methacrylate	ND	ND	9.5 E-04
622-96-8	4-Ethyltoluene <sup>g</sup>	ND	ND	1.0 E-03
142-82-5	n-Heptane	ND	ND	8.3 E-04
66-25-1	Hexaldehyde	ND	ND	7.3 E-03
591-78-6	2-Hexanone	ND	ND	2.1 E-03
2691-41-0	HMX	ND	ND	1.3 E-03
10035-10-6	Hydrogen bromide	ND	ND	1.2 E-01
95-13-6	Indene <sup>j</sup>	7.6 E-07	3.4 E-05	--
75-28-5	Isobutane	ND	ND	4.8 E-02
115-11-7	Isobutylene	ND	ND	4.7 E-02
590-86-3	Isovaleraldehyde	ND	ND	7.3 E-03
7439-95-4	Magnesium <sup>g</sup>	7.5 E-06	3.4 E-04	--
78-93-3	Methyl ethyl ketone <sup>g</sup>	ND	ND	1.5 E-03

TABLE A3 (cont.)

CASRN <sup>a</sup>	Compound	Emission Factor <sup>b,c</sup>		Minimum Detection Level mg/m <sup>3,e</sup>
		lb per item	lb per lb NEW <sup>d</sup>	
98-83-9	alpha-Methylstyrene	1.7 E-06	7.6 E-05	--
479-45-8	Methyl-2,4,6-trinitrophenylnitramine	ND	ND	6.5 E-04
88-74-7	2-Nitroaniline	ND	ND	1.7 E-02
99-09-2	3-Nitroaniline	ND	ND	1.7 E-02
88-72-2	2-Nitrotoluene	ND	ND	6.5 E-04
99-08-1	3-Nitrotoluene	ND	ND	6.5 E-04
99-99-0	4-Nitrotoluene	ND	ND	6.5 E-04
301-02-0	9-Octadecenamide, (Z)- <sup>j</sup>	4.1 E-06	1.9 E-04	--
111-65-9	Octane	ND	ND	9.5 E-04
78-11-5	Pentaerythritol tetranitrate	ND	ND	1.3 E-03
109-66-0	Pentane	ND	ND	6.0 E-02
14797-73-0	Perchlorate	ND	ND	7.1 E-02
536-74-3	Phenylethyne <sup>i</sup>	1.8 E-06	8.0 E-05	--
7664-38-2	Phosphoric acid	ND	ND	1.0 E-01
74-98-6	Propane	ND	ND	3.7 E-02
115-11-7	1-Propene, 2-methyl	ND	ND	4.7 E-02
74-99-7	Propyne	1.8 E-06	8.3 E-05	--
121-82-4	RDX	7.7 E-07	3.5 E-05	--
1334-78-7	o,m,p-Tolualdehyde	ND	ND	2.2 E-02
25323-89-1	Trichloroethane	ND	ND	9.9 E-04
108-67-8	1,3,5-Trimethylbenzene	ND	ND	1.0 E-03
99-35-4	1,3,5-Trinitrobenzene	ND	ND	6.5 E-04
118-96-7	2,4,6-Trinitrotoluene <sup>g</sup>	ND	ND	6.5 E-04
110-62-3	Valeraldehyde	ND	ND	7.3 E-03

<sup>a</sup> CASRN = Chemical Abstracts Service Registry Number.

<sup>b</sup> ND = nondetected.

<sup>c</sup> Emission factors rated C unless otherwise noted.

<sup>d</sup> NEW = Net explosive weight. The NEW for this compound is 2.21 E-02 pounds per item.

<sup>e</sup> Data provided for compounds that were not detected.

<sup>f</sup> Emission factor rated A because of correlation with emission factors for similar ordnance and number of test data points.

<sup>g</sup> Emission factor rated B because of correlation with emission factors for similar ordnance and number of test data points.

<sup>h</sup> Emission factor based upon C-rated test data, but because of correlation with emission factors for similar ordnance and number of data points the factor was upgraded from a D rating to a C rating.

<sup>i</sup> Emission factor rated D because the factor is based upon C-rated test data.

<sup>j</sup> Emission factor rated D because the factor is for a tentatively identified compound.

TABLE A4 COMPOUNDS ANALYZED AND EMISSION FACTORS DEVELOPED FOR  
DODIC B627, M83A3 60-MM ILLUMINATING MORTAR CARTRIDGE (TOTAL)

CASRN <sup>a</sup>	Compound	Emission Factor <sup>b,c</sup>		Minimum Detection Level mg/m <sup>3,e</sup>
		lb per item	lb per lb NEW <sup>d</sup>	
Carbon Dioxide, Criteria Pollutants, Methane, Total Nonmethane Hydrocarbons, and Total Suspended Particulate				
124-38-9	Carbon dioxide <sup>f</sup>	3.8 E-02	6.7 E-02	--
630-08-0	Carbon monoxide <sup>f</sup>	7.5 E-03	1.3 E-02	--
7439-92-1	Lead	2.5 E-04	4.5 E-04	--
74-82-8	Methane	4.0 E-05	7.1 E-05	--
--	Oxides of nitrogen <sup>f</sup>	8.0 E-03	1.4 E-02	--
--	PM-2.5	4.8 E-01	8.4 E-01	--
--	PM-10 <sup>g</sup>	2.0 E-01	3.6 E-01	--
7446-09-5	Sulfur dioxide <sup>f</sup>	1.4 E-04	2.6 E-04	--
--	Total nonmethane hydrocarbons	5.5 E-03	9.7 E-03	--
12789-66-1	Total suspended particulate <sup>g</sup>	2.5 E-01	4.4 E-01	--
Hazardous Air Pollutants and Toxic Chemicals				
83-32-9	Acenaphthene	5.6 E-09	1.0 E-08	--
208-96-8	Acenaphthylene	2.1 E-07	3.7 E-07	--
75-07-0	Acetaldehyde	4.4 E-05	7.8 E-05	--
75-05-8	Acetonitrile <sup>i</sup>	1.3 E-02	2.4 E-02	--
98-86-2	Acetophenone	ND	ND	1.1 E-03
53-96-3	2-Acetylaminofluorene	ND	ND	2.2 E-04
107-02-8	Acrolein	ND	ND	7.3 E-03
107-13-1	Acrylonitrile	2.4 E-07	4.2 E-07	--
107-05-1	Allyl chloride	ND	ND	1.6 E-03
7429-90-5	Aluminum <sup>g</sup>	1.8 E-04	3.1 E-04	--
92-67-1	4-Aminobiphenyl	ND	ND	4.5 E-03
7664-41-7	Ammonia	ND	ND	4.6 E-02
62-53-3	Aniline	ND	ND	3.3 E-03
120-12-7	Anthracene	5.7 E-09	1.0 E-08	--
7440-36-0	Antimony	4.0 E-06	7.1 E-06	--
7440-38-2	Arsenic	ND	ND	5.4 E-05
7440-39-3	Barium	1.9 E-04	3.4 E-04	--
71-43-2	Benzene	1.1 E-04	1.9 E-04	--
92-87-5	Benzidine	ND	ND	2.3 E-02
56-55-3	Benzo[a]anthracene	4.4 E-09	7.9 E-09	--
205-99-2	Benzo[b]fluoranthene	1.5 E-08	2.6 E-08	--



TABLE A4 (cont.)

CASRN <sup>a</sup>	Compound	Emission Factor <sup>b,c</sup>		Minimum Detection Level mg/m <sup>3,e</sup>
		lb per item	lb per lb NEW <sup>d</sup>	
207-08-9	Benzo[k]fluoranthene	7.0 E-09	1.2 E-08	--
191-24-2	Benzo[g,h,i]perylene	6.4 E-09	1.1 E-08	--
50-32-8	Benzo[a]pyrene	1.0 E-08	1.8 E-08	--
192-97-2	Benzo[e]pyrene	9.5 E-09	1.7 E-08	--
100-44-7	Benzyl chloride	ND	ND	6.3 E-03
7440-41-7	Beryllium	1.8 E-07	3.2 E-07	--
75-25-2	Bromoform	ND	ND	2.1 E-03
74-83-9	Bromomethane	ND	ND	7.9 E-04
101-55-3	4-Bromophenylphenylether	ND	ND	2.2 E-04
106-99-0	1,3-Butadiene	2.1 E-05	3.8 E-05	--
71-36-3	Butanol	ND	ND	1.4 E-02
75-65-0	t-Butyl alcohol	ND	ND	6.2 E-04
85-68-7	Butylbenzylphthalate	ND	ND	2.7 E-04
123-72-8	Butyraldehyde	0	0	--
7440-43-9	Cadmium	7.3 E-07	1.3 E-06	--
86-74-8	Carbazole	ND	ND	2.9 E-04
75-15-0	Carbon disulfide	ND	ND	1.6 E-03
56-23-5	Carbon tetrachloride	ND	ND	1.3 E-03
106-47-8	4-Chloroaniline	ND	ND	2.7 E-03
108-90-7	Chlorobenzene	ND	ND	9.4 E-04
75-45-6	Chlorodifluoromethane	ND	ND	3.6 E-03
75-00-3	Chloroethane	ND	ND	5.4 E-04
111-44-4	bis(2-Chloroethyl)ether	ND	ND	2.5 E-04
111-91-1	bis(2-Chloroethoxy)methane	ND	ND	2.2 E-04
67-66-3	Chloroform	ND	ND	9.9 E-04
108-60-1	bis(2-Chloroisopropyl)ether	ND	ND	3.4 E-04
74-87-3	Chloromethane	ND	ND	4.2 E-04
91-58-7	2-Chloronaphthalene	ND	ND	2.2 E-04
95-57-8	2-Chlorophenol	ND	ND	1.7 E-02
7005-72-3	4-chlorophenyl-phenylether	ND	ND	2.2 E-04
7440-47-3	Chromium	2.8 E-06	5.0 E-06	--
18540-29-9	Hexavalent chromium <sup>i</sup>	3.3 E-04	5.9 E-04	--
218-01-9	Chrysene	8.2 E-09	1.5 E-08	--
7440-48-4	Cobalt	3.5 E-07	6.1 E-07	--
7440-50-8	Copper <sup>g</sup>	1.6 E-05	2.8 E-05	--

TABLE A4 (cont.)

CASRN <sup>a</sup>	Compound	Emission Factor <sup>b,c</sup>		Minimum Detection Level mg/m <sup>3,e</sup>
		lb per item	lb per lb NEW <sup>d</sup>	
106-44-5	p-Cresol	ND	ND	1.7 E-02
4170-30-3	Crotonaldehyde	4.1 E-06	7.2 E-06	--
98-82-8	Cumene	ND	ND	1.0 E-03
57-12-5	Particulate cyanide	ND	ND	1.4 E-02
110-82-7	Cyclohexane	ND	ND	4.2 E-03
53-70-3	Dibenz[a,h]anthracene	1.2 E-09	2.1 E-09	--
132-64-9	Dibenzofuran	ND	ND	2.2 E-04
106-93-4	1,2-Dibromoethane	ND	ND	1.6 E-03
84-74-2	Dibutylphthalate	ND	ND	1.3 E-03
10061-02-6	trans-1,3-Dichloro-1-propene	ND	ND	9.2 E-04
95-50-1	1,2-Dichlorobenzene	ND	ND	3.1 E-03
541-73-1	1,3-Dichlorobenzene	ND	ND	3.1 E-03
106-46-7	1,4-Dichlorobenzene	ND	ND	3.1 E-03
91-94-1	3,3'-Dichlorobenzidine	ND	ND	3.3 E-03
75-27-4	Dichlorobromomethane	ND	ND	1.4 E-03
75-71-8	Dichlorodifluoromethane	ND	ND	1.0 E-03
75-34-3	1,1-Dichloroethane	ND	ND	8.2 E-04
107-06-2	1,2-Dichloroethane	2.5 E-06	4.4 E-06	--
75-43-4	Dichlorofluoromethane	ND	ND	8.6 E-04
120-83-2	2,4-Dichlorophenol	ND	ND	9.9 E-03
78-87-5	1,2-Dichloropropane	ND	ND	9.4 E-04
76-14-2	Dichlorotetrafluoroethane	ND	ND	1.4 E-03
131-11-3	Dimethyl phthalate	ND	ND	2.2 E-04
57-97-6	7,12-Dimethylbenz[a]anthracene	ND	ND	2.3 E-04
119-93-7	3,3'-Dimethylbenzidine	ND	ND	2.2 E-02
105-67-9	2,4-Dimethylphenol	ND	ND	2.8 E-03
60-11-7	p-Dimethylaminoazobenzene	ND	ND	2.2 E-04
99-65-0	1,3-Dinitrobenzene	ND	ND	2.4 E-04
534-52-1	4,6-Dinitro-o-cresol	ND	ND	3.9 E-03
51-28-5	2,4-Dinitrophenol	ND	ND	9.9 E-03
121-14-2	2,4-Dinitrotoluene	ND	ND	4.9 E-05
606-20-2	2,6-Dinitrotoluene	ND	ND	7.0 E-05
88-85-7	Dinoseb	ND	ND	4.4 E-04
123-91-1	1,4-Dioxane	ND	ND	7.3 E-04
--	Total dioxin/furan compounds	1.6 E-07	2.9 E-07	--

TABLE A4 (cont.)

CASRN <sup>a</sup>	Compound	Emission Factor <sup>b,c</sup>		Minimum Detection Level mg/m <sup>3,e</sup>
		lb per item	lb per lb NEW <sup>d</sup>	
122-39-4	Diphenylamine	ND	ND	2.2 E-04
122-66-7	1,2-Diphenylhydrazine	ND	ND	2.2 E-04
140-88-5	Ethyl acrylate	ND	ND	8.3 E-04
100-41-4	Ethylbenzene	3.7 E-05	6.6 E-05	--
74-85-1	Ethylene	3.7 E-05	6.5 E-05	--
117-81-7	bis(2-Ethylhexyl)phthalate	ND	ND	1.3 E-03
206-44-0	Fluoranthene	4.3 E-09	7.5 E-09	--
86-73-7	Fluorene	5.5 E-08	9.7 E-08	--
50-00-0	Formaldehyde	8.7 E-06	1.6 E-05	--
76-13-1	Freon 113	ND	ND	3.9 E-03
35822-46-9	1,2,3,4,6,7,8-Heptachlorodibenzo-p-dioxin	2.9 E-08	5.1 E-08	--
67562-39-4	1,2,3,4,6,7,8-Heptachlorodibenzofuran <sup>i</sup>	3.3 E-09	5.8 E-09	--
55673-89-7	1,2,3,4,7,8,9-Heptachlorodibenzofuran <sup>i</sup>	4.2 E-09	7.5 E-09	--
118-74-1	Hexachlorobenzene	ND	ND	2.2 E-04
87-68-3	Hexachlorobutadiene	ND	ND	5.4 E-03
77-47-4	Hexachlorocyclopentadiene	ND	ND	4.5 E-03
39227-28-6	1,2,3,4,7,8-Hexachlorodibenzo-p-dioxin	ND	ND	1.3 E-09
57653-85-7	1,2,3,6,7,8-Hexachlorodibenzo-p-dioxin <sup>i</sup>	2.8 E-09	5.0 E-09	--
19408-74-3	1,2,3,7,8,9-Hexachlorodibenzo-p-dioxin <sup>i</sup>	4.0 E-09	7.0 E-09	--
70648-26-9	1,2,3,4,7,8-Hexachlorodibenzofuran <sup>i</sup>	4.0 E-09	7.1 E-09	--
57117-44-9	1,2,3,6,7,8-Hexachlorodibenzofuran <sup>i</sup>	2.3 E-09	4.1 E-09	--
72918-21-9	1,2,3,7,8,9-Hexachlorodibenzofuran <sup>i</sup>	5.8 E-09	1.0 E-08	--
60851-34-5	2,3,4,6,7,8-Hexachlorodibenzofuran <sup>i</sup>	1.9 E-09	3.3 E-09	--
67-72-1	Hexachloroethane	ND	ND	2.4 E-04
110-54-3	Hexane	3.3 E-05	5.8 E-05	--
7647-01-0	Hydrochloric acid	ND	ND	7.1 E-02
74-90-8	Hydrogen cyanide	1.2 E-04	2.1 E-04	--
7664-39-3	Hydrogen fluoride	ND	ND	1.8 E-01
193-39-5	Indeno[1,2,3-cd]pyrene	7.5 E-09	1.3 E-08	--
78-59-1	Isophorone	ND	ND	2.2 E-04

TABLE A4 (cont.)

CASRN <sup>a</sup>	Compound	Emission Factor <sup>b,c</sup>		Minimum Detection Level mg/m <sup>3,e</sup>
		lb per item	lb per lb NEW <sup>d</sup>	
67-63-0	Isopropyl alcohol	ND	ND	1.1 E-02
120-58-1	Isosafrole	ND	ND	2.2 E-04
7439-96-5	Manganese <sup>g</sup>	4.5 E-06	8.1 E-06	--
7439-97-6	Mercury	ND	ND	1.2 E-05
126-98-7	Methacrylonitrile	ND	ND	2.6 E-01
96-33-3	Methyl acrylate	ND	ND	7.2 E-04
74-88-4	Methyl iodide	ND	ND	1.2 E-03
108-10-1	Methyl isobutyl ketone	ND	ND	2.1 E-03
80-62-6	Methyl methacrylate	ND	ND	8.3 E-04
1634-04-4	Methyl tert-butyl ether	ND	ND	7.3 E-04
56-49-5	3-Methylcholanthrene	ND	ND	2.2 E-04
74-95-3	Methylene bromide	ND	ND	1.4 E-03
75-09-2	Methylene chloride	2.1 E-05	3.7 E-05	--
91-57-6	2-Methylnaphthalene	2.3 E-07	4.2 E-07	--
95-48-7	2-Methylphenol	ND	ND	1.3 E-03
91-20-3	Naphthalene <sup>g</sup>	2.5 E-06	4.5 E-06	--
134-32-7	1-Naphthylamine	ND	ND	4.5 E-03
91-59-8	2-Naphthylamine	ND	ND	4.5 E-03
7440-02-0	Nickel	1.1 E-06	1.9 E-06	--
7697-37-2	Nitric acid	ND	ND	1.0 E-01
100-01-6	4-Nitroaniline	ND	ND	9.0 E-04
98-95-3	Nitrobenzene	ND	ND	1.7 E-04
55-63-0	Nitroglycerin	2.0 E-07	3.6 E-07	--
99-55-8	5-Nitro-o-toluidine	ND	ND	3.6 E-03
88-75-5	2-Nitrophenol	ND	ND	2.2 E-04
100-02-7	4-Nitrophenol	ND	ND	1.5 E-03
79-46-9	2-Nitropropane	ND	ND	3.4 E-01
924-16-3	n-Nitroso-di-n-butylamine	ND	ND	2.2 E-04
55-18-5	n-Nitrosodiethylamine	ND	ND	2.2 E-04
62-75-9	n-Nitrosodimethylamine	ND	ND	2.2 E-04
86-30-6	n-Nitrosodiphenylamine	ND	ND	3.9 E-04
621-64-7	n-Nitroso-di-n-propylamine	ND	ND	2.2 E-04
59-89-2	n-Nitrosomorpholine	ND	ND	2.2 E-04
100-75-4	n-Nitrosopiperidine	ND	ND	2.2 E-04

TABLE A4 (cont.)

CASRN <sup>a</sup>	Compound	Emission Factor <sup>b,c</sup>		Minimum Detection Level mg/m <sup>3,e</sup>
		lb per item	lb per lb NEW <sup>d</sup>	
3268-87-9	1,2,3,4,6,7,8,9-Octachlorodibenzo-p-dioxin	9.4 E-08	1.7 E-07	--
39001-02-0	1,2,3,4,6,7,8,9-Octachlorodibenzofuran <sup>i</sup>	8.3 E-09	1.5 E-08	--
608-93-5	Pentachlorobenzene	ND	ND	2.2 E-04
40321-76-4	1,2,3,7,8-Pentachlorodibenzo-p-dioxin	0	0	--
57117-41-6	1,2,3,7,8-Pentachlorodibenzofuran <sup>i</sup>	2.6 E-09	4.5 E-09	--
57117-31-4	2,3,4,7,8-Pentachlorodibenzofuran	ND	ND	8.7 E-10
76-01-7	Pentachloroethane	ND	ND	2.2 E-04
82-68-8	Pentachloronitrobenzene	ND	ND	2.2 E-04
87-86-5	Pentachlorophenol	ND	ND	1.1 E-02
85-01-8	Phenanthrene	3.3 E-08	5.9 E-08	--
108-95-2	Phenol	1.2 E-06	2.2 E-06	--
7723-14-0	Phosphorus	1.0 E-04	1.8 E-04	--
123-38-6	Propionaldehyde	5.0 E-06	8.9 E-06	--
115-07-1	Propylene	5.4 E-06	9.5 E-06	--
129-00-0	Pyrene	1.6 E-11	2.9 E-11	--
110-86-1	Pyridine	5.8 E-07	1.0 E-06	--
94-59-7	Safrole	ND	ND	2.2 E-04
7782-49-2	Selenium	ND	ND	4.6 E-05
7440-22-4	Silver	ND	ND	1.2 E-04
100-42-5	Styrene	2.8 E-05	5.0 E-05	--
7664-93-9	Sulfuric acid	ND	ND	1.2 E-01
51207-31-9	2,3,7,8-Tetrachlorodibenzofuran	ND	ND	7.9 E-10
1746-01-6	2,3,7,8-Tetrachlorodibenzo-p-dioxin	ND	ND	8.7 E-10
630-20-6	1,1,1,2-Tetrachloroethane	ND	ND	1.4 E-03
79-34-5	1,1,2,2-Tetrachloroethane	ND	ND	1.4 E-03
127-18-4	Tetrachloroethylene	ND	ND	1.4 E-03
7440-28-0	Thallium	7.9 E-07	1.4 E-06	--
108-88-3	Toluene	3.4 E-05	6.1 E-05	--
95-53-4	o-Toluidine	ND	ND	2.9 E-03
120-82-1	1,2,4-Trichlorobenzene	ND	ND	7.5 E-03
71-55-6	1,1,1-Trichloroethane	ND	ND	1.1 E-03
79-00-5	1,1,2-Trichloroethane	ND	ND	1.1 E-03
79-01-6	Trichloroethylene	ND	ND	6.6 E-03

TABLE A4 (cont.)

CASRN <sup>a</sup>	Compound	Emission Factor <sup>b,c</sup>		Minimum Detection Level mg/m <sup>3,e</sup>
		lb per item	lb per lb NEW <sup>d</sup>	
75-69-4	Trichlorofluoromethane	ND	ND	1.1 E-03
95-95-4	2,4,5-Trichlorophenol	ND	ND	5.8 E-04
88-06-2	2,4,6-Trichlorophenol	ND	ND	3.4 E-04
96-18-4	1,2,3-Trichloropropane	ND	ND	1.2 E-03
95-63-6	1,2,4-Trimethylbenzene <sup>i</sup>	4.2 E-05	7.4 E-05	--
540-84-1	2,2,4-Trimethylpentane	ND	ND	9.5 E-04
7440-62-2	Vanadium	ND	ND	4.0 E-04
108-05-4	Vinyl acetate	ND	ND	7.2 E-04
75-01-4	Vinyl chloride	ND	ND	5.2 E-04
75-35-4	Vinylidene chloride	ND	ND	8.1 E-04
106-42-3, 108-38-3	m-Xylene, p-Xylene <sup>g</sup>	6.2 E-05	1.1 E-04	--
95-47-6	o-Xylene	4.1 E-05	7.2 E-05	--
7440-66-6	Zinc	1.6 E-03	2.8 E-03	--
Other Pollutants				
67-64-1	Acetone	5.8 E-07	1.0 E-06	--
74-86-2	Acetylene	2.6 E-05	4.5 E-05	--
35572-78-2	2-Amino-4,6-dinitrotoluene	ND	ND	3.1 E-05
19406-51-0	4-Amino-2,6-dinitrotoluene	ND	ND	2.8 E-05
100-52-7	Benzaldehyde	2.4 E-06	4.3 E-06	--
65-85-0	Benzoic acid	ND	ND	2.1 E-02
100-51-6	Benzyl alcohol	ND	ND	1.6 E-02
108-86-1	Bromobenzene	ND	ND	1.3 E-03
106-97-8	Butane	ND	ND	5.3 E-02
78-78-4	Butane, 2-methyl <sup>j</sup>	2.9 E-04	5.2 E-04	--
106-98-9	1-Butene	ND	ND	4.7 E-02
590-18-1	cis-2-Butene	ND	ND	4.7 E-02
624-64-6	trans-2-Butene	ND	ND	4.7 E-02
107-00-6	1-Butyne	ND	ND	4.5 E-02
503-17-3	2-Butyne	ND	ND	4.5 E-02
7440-44-0	Elemental carbon	2.5 E-06	4.5 E-06	--
7440-44-0	Organic carbon	3.3 E-05	5.9 E-05	--
7440-44-0	Total carbon	3.6 E-05	6.3 E-05	--
59-50-7	4-Chloro-3-methylphenol	ND	ND	2.8 E-04
107-14-2	Chloroacetonitrile	ND	ND	2.9 E-01

TABLE A4 (cont.)

CASRN <sup>a</sup>	Compound	Emission Factor <sup>b,c</sup>		Minimum Detection Level mg/m <sup>3,e</sup>
		lb per item	lb per lb NEW <sup>d</sup>	
109-69-3	1-Chlorobutane	ND	ND	8.9 E-01
39638-32-9	bis(2-Chloroisopropyl)ether	ND	ND	1.7 E-02
95-57-8	2-Chlorophenol	ND	ND	2.2 E-04
90-13-1	1-Chloronaphthalene	ND	ND	2.2 E-04
287-92-3	Cyclopentane	ND	ND	2.7 E-01
120-92-3	Cyclopentanone <sup>i</sup>	6.7 E-06	1.2 E-05	--
124-18-5	n-Decane	ND	ND	5.4 E-01
124-48-1	Dibromochloromethane	ND	ND	1.7 E-03
156-59-2	cis-1,2-Dichloroethene	ND	ND	8.1 E-04
156-60-5	trans-1,2-Dichloroethene	ND	ND	8.1 E-04
87-65-0	2,6-Dichlorophenol	ND	ND	2.2 E-04
10061-01-5	cis-1,3-Dichloropropene	ND	ND	9.2 E-04
141-93-5	1,3-Diethylbenzene	ND	ND	5.1 E-01
105-05-5	1,4-Diethylbenzene	ND	ND	5.1 E-01
84-66-2	Diethylphthalate	4.6 E-07	8.2 E-07	--
5779-94-2	2,5-Dimethylbenzaldehyde	ND	ND	5.9 E-04
75-83-2	2,2-Dimethylbutane	ND	ND	3.3 E-01
79-29-8	2,3-Dimethylbutane	ND	ND	3.3 E-01
565-59-3	2,3-Dimethylpentane	ND	ND	3.8 E-01
108-08-7	2,4-Dimethylpentane	ND	ND	3.8 E-01
117-84-0	Di-n-octylphthalate	ND	ND	2.5 E-04
74-84-0	Ethane <sup>g</sup>	2.0 E-06	3.6 E-06	--
64-17-5	Ethanol	ND	ND	8.8 E-03
141-78-6	Ethyl acetate	ND	ND	7.3 E-04
60-29-7	Ethyl ether	ND	ND	2.8 E-01
97-63-2	Ethyl methacrylate	ND	ND	9.5 E-04
62-50-0	Ethyl methanesulfonate	ND	ND	2.2 E-04
622-96-8	4-Ethyltoluene <sup>g</sup>	ND	ND	1.0 E-03
620-14-4	m-Ethyltoluene	ND	ND	4.6 E-01
611-14-3	o-Ethyltoluene	ND	ND	4.6 E-01
98-01-1	2-Furancarboxaldehyde <sup>j</sup>	5.4 E-06	9.5 E-06	--
142-82-5	n-Heptane	ND	ND	8.3 E-04
1888-71-7	Hexachloropropene	ND	ND	3.2 E-04
66-25-1	Hexaldehyde	1.5 E-06	2.7 E-06	--
592-41-6	1-Hexene	ND	ND	3.2 E-01

TABLE A4 (cont.)

CASRN <sup>a</sup>	Compound	Emission Factor <sup>b,c</sup>		Minimum Detection Level mg/m <sup>3,e</sup>
		lb per item	lb per lb NEW <sup>d</sup>	
591-78-6	2-Hexanone	ND	ND	2.1 E-03
2691-41-0	HMX <sup>i</sup>	1.4 E-05	2.4 E-05	--
10035-10-6	Hydrogen bromide	ND	ND	1.2 E-01
95-13-6	Indene <sup>j</sup>	7.6 E-07	1.3 E-06	--
75-28-5	Isobutane	ND	ND	4.8 E-02
115-11-7	Isobutylene	ND	ND	4.7 E-02
78-79-5	Isoprene	ND	ND	2.6 E-01
590-86-3	Isovaleraldehyde	1.0 E-06	1.8 E-06	--
5989-27-5	d-Limonene	ND	ND	2.6 E-02
7439-95-4	Magnesium <sup>g</sup>	9.1 E-02	1.6 E-01	--
593-75-9	Methane, isocyano- <sup>j</sup>	6.9 E-03	1.2 E-02	--
78-93-3	Methyl ethyl ketone <sup>g</sup>	ND	ND	1.5 E-03
66-27-3	Methyl methanesulfonate	ND	ND	2.5 E-04
479-45-8	Methyl-2,4,6-trinitrophenylnitramine <sup>i</sup>	3.3 E-07	5.8 E-07	--
108-87-2	Methylcyclohexane	ND	ND	3.8 E-01
96-37-7	Methylcyclopentane	ND	ND	3.2 E-01
592-27-8	2-Methylheptane	ND	ND	4.2 E-01
589-81-1	3-Methylheptane	ND	ND	4.4 E-01
591-76-4	2-Methylhexane	ND	ND	3.8 E-01
589-34-4	3-Methylhexane	ND	ND	3.8 E-01
107-83-5	2-Methylpentane	ND	ND	3.3 E-01
96-14-0	3-Methylpentane	ND	ND	3.3 E-01
98-83-9	alpha-Methylstyrene	1.7 E-06	3.0 E-06	--
88-74-4	2-Nitroaniline	ND	ND	2.2 E-04
99-09-2	3-Nitroaniline	ND	ND	9.0 E-04
10595-95-6	N-Nitrosomethylethylamine	ND	ND	3.7 E-04
930-55-2	N-Nitrosopyrrolidine	ND	ND	2.2 E-04
88-72-2	2-Nitrotoluene	ND	ND	1.5 E-04
99-08-1	3-Nitrotoluene	ND	ND	6.5 E-04
99-99-0	4-Nitrotoluene <sup>i</sup>	3.4 E-06	6.1 E-06	--
111-84-2	n-Nonane	ND	ND	4.9 E-01
301-02-0	9-Octadecenamamide, (Z)- <sup>j</sup>	4.1 E-06	7.3 E-06	--
111-65-9	Octane	ND	ND	9.5 E-04
78-11-5	Pentaerythritol tetranitrate	ND	ND	1.5 E-04



TABLE A4 (cont.)

CASRN <sup>a</sup>	Compound	Emission Factor <sup>b,c</sup>		Minimum Detection Level mg/m <sup>3,e</sup>
		lb per item	lb per lb NEW <sup>d</sup>	
109-66-0	Pentane	ND	ND	6.0 E-02
78-78-4	i-Pentane	ND	ND	2.8 E-01
109-67-1	1-Pentene	ND	ND	2.7 E-01
627-20-3	cis-2-Pentene	ND	ND	2.7 E-01
646-04-8	trans-2-Pentene	ND	ND	2.7 E-01
14797-73-0	Perchlorate	4.9 E-06	8.6 E-06	--
62-44-2	Phenacetin	ND	ND	2.2 E-04
536-74-3	Phenylethyne <sup>j</sup>	1.8 E-06	3.1 E-06	--
791-28-6	Phosphine oxide, triphenyl <sup>j</sup>	7.7 E-06	1.4 E-05	--
7664-38-2	Phosphoric acid	ND	ND	1.0 E-01
80-56-8	alpha-Pinene	ND	ND	2.6 E-02
127-91-3	beta-Pinene	ND	ND	2.6 E-02
74-98-6	Propane	ND	ND	3.7 E-02
115-11-7	1-Propene, 2-methyl	ND	ND	4.7 E-02
103-65-1	n-Propylbenzene	ND	ND	6.0 E-03
74-99-7	Propyne	1.8 E-06	3.2 E-06	--
504-31-4	2H-Pyran-2-one <sup>j</sup>	6.2 E-05	1.1 E-04	--
121-82-4	RDX	7.7 E-07	1.4 E-06	--
95-94-3	1,2,4,5-Tetrachlorobenzene	ND	ND	2.2 E-04
58-90-2	2,3,4,6-Tetrachlorophenol	ND	ND	2.9 E-04
109-99-9	Tetrahydrofuran	ND	ND	1.4 E-02
1334-78-7	o,m,p-Tolualdehyde	9.2 E-07	1.6 E-06	--
25323-89-1	Trichloroethane	ND	ND	9.9 E-04
526-73-8	1,2,3-Trimethylbenzene	ND	ND	4.6 E-01
108-67-8	1,3,5-Trimethylbenzene	ND	ND	1.9 E-04
565-75-3	2,3,4-Trimethylpentane	ND	ND	4.4 E-01
99-35-4	1,3,5-Trinitrobenzene	ND	ND	1.9 E-04
118-96-7	2,4,6-Trinitrotoluene	ND	ND	3.0 E-05
1120-21-4	Undecane	ND	ND	6.0 E-01
110-62-3	Valeraldehyde	9.3 E-07	1.7 E-06	--

TABLE A4 (cont.)

- <sup>a</sup> CASRN = Chemical Abstracts Service Registry Number.
- <sup>b</sup> ND = nondetected.
- <sup>c</sup> Emission factors rated C unless otherwise noted.
- <sup>d</sup> NEW = Net explosive weight. The NEW for this compound is 5.64 E-01 pounds per item.
- <sup>e</sup> Data provided for compounds that were not detected.
- <sup>f</sup> Emission factor rated A because of correlation with emission factors for similar ordnance and number of test data points.
- <sup>g</sup> Emission factor rated B because of correlation with emission factors for similar ordnance and number of test data points.
- <sup>h</sup> Emission factor based upon C-rated test data, but because of correlation with emission factors for similar ordnance and number of data points the factor was upgraded from a D rating to a C rating.
- <sup>i</sup> Emission factor rated D because the factor is based upon C-rated test data.
- <sup>j</sup> Emission factor rated D because the factor is for a tentatively identified compound.

DRAFT

TABLE A5 COMPOUNDS ANALYZED AND EMISSION FACTORS DEVELOPED FOR  
DODIC B645, M766 60-MM SHORT RANGE PRACTICE MORTAR CARTRIDGE  
(PROPELLING CHARGE ONLY)

CASRN <sup>a</sup>	Compound	Emission Factor <sup>b,c</sup>		Minimum Detection Level mg/m <sup>3,e</sup>
		lb per item	lb per lb NEW <sup>d</sup>	
Carbon Dioxide, Criteria Pollutants, Methane, and Total Suspended Particulate				
124-38-9	Carbon dioxide <sup>f</sup>	6.3 E-03	9.6 E-01	--
630-08-0	Carbon monoxide <sup>f</sup>	7.8 E-03	1.2	--
7439-92-1	Lead <sup>g</sup>	1.3 E-05	2.0 E-03	--
74-82-8	Methane <sup>f</sup>	2.6 E-05	3.9 E-03	--
--	Oxides of nitrogen <sup>f</sup>	9.8 E-05	1.5 E-02	--
--	PM-2.5 <sup>g</sup>	1.2 E-03	1.9 E-01	--
--	PM-10 <sup>g</sup>	1.4 E-03	2.1 E-01	--
7446-09-5	Sulfur dioxide	ND	ND	2.7 E-01
12789-66-1	Total suspended particulate <sup>g</sup>	1.3 E-03	1.9 E-01	--
Hazardous Air Pollutants and Toxic Chemicals				
83-32-9	Acenaphthene <sup>g</sup>	4.3 E-10	6.6 E-08	--
208-96-8	Acenaphthylene <sup>g</sup>	1.3 E-08	2.0 E-06	--
75-07-0	Acetaldehyde <sup>g</sup>	1.2 E-06	1.8 E-04	--
75-05-8	Acetonitrile	2.4 E-06	3.6 E-04	--
107-02-8	Acrolein	ND	ND	7.6 E-03
107-13-1	Acrylonitrile <sup>g</sup>	3.6 E-07	5.5 E-05	--
107-05-1	Allyl chloride	ND	ND	1.6 E-03
7429-90-5	Aluminum <sup>g</sup>	2.9 E-05	4.4 E-03	--
7664-41-7	Ammonia <sup>f</sup>	1.5 E-05	2.3 E-03	--
120-12-7	Anthracene <sup>g</sup>	ND	ND	1.7 E-02
7440-36-0	Antimony	7.5 E-06	1.1 E-03	--
7440-38-2	Arsenic	3.7 E-08	5.7 E-06	--
7440-39-3	Barium	7.1 E-06	1.1 E-03	--
71-43-2	Benzene	4.1 E-06	6.2 E-04	--
56-55-3	Benzo[a]anthracene <sup>g</sup>	ND	ND	1.7 E-05
205-99-2	Benzo[b]fluoranthene <sup>g</sup>	4.9 E-10	7.5 E-08	--
207-08-9	Benzo[k]fluoranthene <sup>g</sup>	2.2 E-10	3.3 E-08	--
191-24-2	Benzo[g,h,i]perylene <sup>g</sup>	2.2 E-09	3.4 E-07	--
50-32-8	Benzo[a]pyrene <sup>g</sup>	ND	ND	1.7 E-02
192-97-2	Benzo[e]pyrene <sup>g</sup>	7.1 E-10	1.1 E-07	--
7440-41-7	Beryllium	ND	ND	4.0 E-04
75-25-2	Bromoform	ND	ND	2.1 E-03

TABLE A5 (cont.)

CASRN <sup>a</sup>	Compound	Emission Factor <sup>b,c</sup>		Minimum Detection Level mg/m <sup>3,e</sup>
		lb per item	lb per lb NEW <sup>d</sup>	
74-83-9	Bromomethane	ND	ND	7.9 E-04
101-55-3	4-Bromophenylphenylether	ND	ND	1.7 E-02
106-99-0	1,3-Butadiene	ND	ND	4.5 E-02
75-65-0	t-Butyl alcohol	ND	ND	6.2 E-04
85-68-7	Butylbenzylphthalate	ND	ND	1.7 E-02
123-72-8	Butyraldehyde	ND	ND	7.6 E-03
7440-43-9	Cadmium	7.4 E-08	1.1 E-05	--
75-15-0	Carbon disulfide	ND	ND	1.6 E-03
56-23-5	Carbon tetrachloride	ND	ND	1.3 E-03
106-47-8	4-Chloroaniline	ND	ND	1.7 E-02
108-90-7	Chlorobenzene	ND	ND	9.4 E-04
75-45-6	Chlorodifluoromethane	ND	ND	3.6 E-03
75-00-3	Chloroethane	ND	ND	5.4 E-04
111-91-1	bis(2-Chloroethoxy)methane	ND	ND	1.7 E-02
111-44-4	bis(2-Chloroethyl)ether	ND	ND	1.7 E-02
67-66-3	Chloroform	ND	ND	9.9 E-04
74-87-3	Chloromethane	ND	ND	4.2 E-04
91-58-7	2-Chloronaphthalene	ND	ND	1.7 E-02
95-57-8	2-Chlorophenol	ND	ND	1.7 E-02
7005-72-3	4-Chlorophenyl-phenylether	ND	ND	1.7 E-02
7440-47-3	Chromium	1.2 E-07	1.8 E-05	--
18540-29-9	Hexavalent chromium	ND	ND	5.8 E-01
218-01-9	Chrysene	ND	ND	1.7 E-05
7440-48-4	Cobalt	ND	ND	4.0 E-04
106-44-5	p-Cresol	ND	ND	1.7 E-02
4170-30-3	Crotonaldehyde	ND	ND	7.6 E-03
98-82-8	Cumene	ND	ND	1.0 E-03
57-12-5	Particulate cyanide	ND	ND	1.3 E-02
53-70-3	Dibenz[a,h]anthracene <sup>g</sup>	ND	ND	1.7 E-05
132-64-9	Dibenzofuran	ND	ND	1.7 E-02
106-93-4	1,2-Dibromoethane	ND	ND	1.6 E-03
84-74-2	Dibutyl phthalate	ND	ND	1.3 E-03
95-50-1	1,2-Dichlorobenzene	ND	ND	3.1 E-03
541-73-1	1,3-Dichlorobenzene	ND	ND	3.1 E-03
106-46-7	1,4-Dichlorobenzene	ND	ND	3.1 E-03

TABLE A5 (cont.)

CASRN <sup>a</sup>	Compound	Emission Factor <sup>b,c</sup>		Minimum Detection Level mg/m <sup>3,e</sup>
		lb per item	lb per lb NEW <sup>d</sup>	
75-27-4	Dichlorobromomethane	ND	ND	1.4 E-03
75-71-8	Dichlorodifluoromethane <sup>g</sup>	ND	ND	1.0 E-03
75-34-3	1,1-Dichloroethane	ND	ND	8.2 E-04
107-06-2	1,2-Dichloroethane	ND	ND	8.2 E-04
75-43-4	Dichlorofluoromethane	ND	ND	8.6 E-04
120-83-2	2,4-Dichlorophenol	ND	ND	1.7 E-02
78-87-5	1,2-Dichloropropane	ND	ND	9.4 E-04
10061-02-6	trans-1,3-Dichloropropene	ND	ND	9.2 E-04
76-14-2	Dichlorotetrafluoroethane	ND	ND	1.4 E-03
105-67-9	2,4-Dimethylphenol	ND	ND	1.7 E-02
131-11-3	Dimethyl phthalate	ND	ND	1.7 E-02
99-65-0	1,3-Dinitrobenzene	ND	ND	6.5 E-04
534-52-1	4,6-Dinitro-2-methylphenol	ND	ND	1.7 E-02
51-28-5	2,4-Dinitrophenol	ND	ND	1.7 E-02
121-14-2	2,4-Dinitrotoluene	ND	ND	6.5 E-04
606-20-2	2,6-Dinitrotoluene	ND	ND	6.5 E-04
123-91-1	1,4-Dioxane	ND	ND	7.3 E-04
--	Total dioxin/furan compounds	6.6 E-14	1.0 E-11	--
122-39-4	Diphenyl amine	ND	ND	1.3 E-03
140-88-5	Ethyl acrylate	ND	ND	8.3 E-04
100-41-4	Ethylbenzene	ND	ND	8.8 E-04
74-85-1	Ethylene <sup>g</sup>	6.4 E-06	9.7 E-04	--
117-81-7	bis(2-Ethylhexyl)phthalate	ND	ND	1.3 E-03
206-44-0	Fluoranthene <sup>g</sup>	4.3 E-10	6.6 E-08	--
86-73-7	Fluorene <sup>g</sup>	1.5 E-09	2.3 E-07	--
50-00-0	Formaldehyde <sup>g</sup>	2.1 E-06	3.2 E-04	--
76-13-1	Freon 113 <sup>g</sup>	ND	ND	3.9 E-03
118-74-1	Hexachlorobenzene	ND	ND	1.7 E-02
87-68-3	Hexachlorobutadiene	ND	ND	5.4 E-03
77-47-4	Hexachlorocyclopentadiene	ND	ND	1.7 E-02
67-72-1	Hexachloroethane	ND	ND	2.0 E-03
110-54-3	Hexane	ND	ND	7.2 E-02
7647-01-0	Hydrochloric acid	1.1 E-04	1.7 E-02	--
74-90-8	Hydrogen cyanide <sup>g</sup>	3.8 E-06	5.7 E-04	--
7664-39-3	Hydrogen fluoride	ND	ND	2.0 E-01

TABLE A5 (cont.)

CASRN <sup>a</sup>	Compound	Emission Factor <sup>b,c</sup>		Minimum Detection Level mg/m <sup>3,e</sup>
		lb per item	lb per lb NEW <sup>d</sup>	
193-39-5	Indeno[1,2,3-cd]pyrene <sup>f</sup>	1.3 E-09	2.0 E-07	--
78-59-1	Isophorone	ND	ND	1.7 E-02
7439-96-5	Manganese <sup>f</sup>	7.4 E-08	1.1 E-05	--
96-33-3	Methyl acrylate	ND	ND	7.2 E-04
74-95-3	Methylene bromide	ND	ND	1.4 E-03
75-09-2	Methylene chloride <sup>g</sup>	8.6 E-06	1.3 E-03	--
74-88-4	Methyl iodide	ND	ND	1.2 E-03
108-10-1	Methyl isobutyl ketone	ND	ND	2.1 E-03
80-62-6	Methyl methacrylate	ND	ND	8.3 E-04
91-57-6	2-Methylnaphthalene	ND	ND	1.7 E-02
95-48-7	2-Methylphenol	ND	ND	1.7 E-02
1634-04-4	Methyl tert-butyl ether	ND	ND	7.3 E-04
91-20-3	Naphthalene <sup>g</sup>	1.3 E-07	2.0 E-05	--
7440-02-0	Nickel	3.7 E-08	5.7 E-06	--
7697-37-2	Nitric acid <sup>g</sup>	ND	ND	1.1 E-01
100-01-6	4-Nitroaniline	ND	ND	1.7 E-02
98-95-3	Nitrobenzene	ND	ND	6.5 E-04
55-63-0	Nitroglycerin	0	0	--
88-75-5	2-Nitrophenol	ND	ND	1.7 E-02
100-02-7	4-Nitrophenol	ND	ND	1.7 E-02
62-75-9	n-Nitrosodimethylamine	ND	ND	1.7 E-02
86-30-6	n-Nitrosodiphenylamine	ND	ND	1.7 E-02
621-64-7	n-Nitroso-di-n-propylamine	ND	ND	1.7 E-02
40321-76-4	1,2,3,7,8-Pentachlorodibenzo-p-dioxin	ND	ND	3.9 E-09
57117-41-6	1,2,3,7,8-Pentachlorodibenzofuran	6.1 E-14	9.3 E-12	--
57117-31-4	2,3,4,7,8-Pentachlorodibenzofuran	1.9 E-14	2.9 E-12	--
87-86-5	Pentachlorophenol	ND	ND	1.7 E-02
85-01-8	Phenanthrene <sup>g</sup>	ND	ND	1.7 E-02
108-95-2	Phenol <sup>g</sup>	ND	ND	1.7 E-02
123-38-6	Propionaldehyde	ND	ND	7.6 E-03
115-07-1	Propylene	ND	ND	3.5 E-02
129-00-0	Pyrene <sup>g</sup>	ND	ND	1.7 E-02
7782-49-2	Selenium	ND	ND	4.0 E-04
7440-22-4	Silver	ND	ND	4.0 E-04

TABLE A5 (cont.)

CASRN <sup>a</sup>	Compound	Emission Factor <sup>b,c</sup>		Minimum Detection Level mg/m <sup>3,e</sup>
		lb per item	lb per lb NEW <sup>d</sup>	
100-42-5	Styrene	ND	ND	8.7 E-04
7664-93-9	Sulfuric acid <sup>g</sup>	ND	ND	1.2 E-01
1746-01-6	2,3,7,8-Tetrachlorodibenzo-p-dioxin <sup>g</sup>	ND	ND	1.6 E-09
51207-31-9	2,3,7,8-Tetrachlorodibenzofuran	ND	ND	1.4 E-09
630-20-6	1,1,1,2-Tetrachloroethane	ND	ND	1.4 E-03
79-34-5	1,1,2,2-Tetrachloroethane	ND	ND	1.4 E-03
127-18-4	Tetrachloroethylene	ND	ND	1.4 E-03
7440-28-0	Thallium	ND	ND	4.0 E-04
108-88-3	Toluene <sup>h</sup>	7.9 E-07	1.2 E-04	--
120-82-1	1,2,4-Trichlorobenzene	ND	ND	7.5 E-03
71-55-6	1,1,1-Trichloroethane	ND	ND	1.1 E-03
79-00-5	1,1,2-Trichloroethane	ND	ND	1.1 E-03
75-69-4	Trichlorofluoromethane	ND	ND	1.1 E-03
95-95-4	2,4,5-Trichlorophenol	ND	ND	1.7 E-02
88-06-2	2,4,6-Trichlorophenol	ND	ND	1.7 E-02
96-18-4	1,2,3-Trichloropropane	ND	ND	1.2 E-03
95-63-6	1,2,4-Trimethylbenzene	ND	ND	1.0 E-03
540-84-1	2,2,4-Trimethylpentane	ND	ND	9.5 E-04
7440-62-2	Vanadium	2.2 E-08	3.4 E-06	--
108-05-4	Vinyl acetate	ND	ND	7.2 E-04
75-01-4	Vinyl chloride	ND	ND	5.2 E-04
75-35-4	Vinylidene chloride <sup>g</sup>	ND	ND	8.1 E-04
106-42-3, 108-38-3	m-Xylene, p-Xylene <sup>g</sup>	ND	ND	8.8 E-04
95-47-6	o-Xylene <sup>g</sup>	ND	ND	8.8 E-04
7440-66-6	Zinc	3.8 E-04	5.8 E-02	--
Other Pollutants				
67-64-1	Acetone	ND	ND	1.4 E-02
74-86-2	Acetylene <sup>g</sup>	3.5 E-06	5.4 E-04	--
35572-78-2	2-Amino-4,6-dinitrotoluene	ND	ND	6.5 E-04
19406-51-0	4-Amino-2,6-dinitrotoluene	ND	ND	6.5 E-04
100-52-7	Benzaldehyde	3.8 E-08	5.7 E-06	--
100-51-6	Benzyl alcohol	ND	ND	1.7 E-02
108-86-1	Bromobenzene	ND	ND	1.3 E-03

TABLE A5 (cont.)

CASRN <sup>a</sup>	Compound	Emission Factor <sup>b,c</sup>		Minimum Detection Level mg/m <sup>3,e</sup>
		lb per item	lb per lb NEW <sup>d</sup>	
106-97-8	Butane	ND	ND	5.3 E-02
123-92-2	1-Butanol, 3-methyl-, acetate <sup>i</sup>	1.1 E-06	1.6 E-04	--
106-98-9	1-Butene	ND	ND	4.7 E-02
590-18-1	cis-Butene	ND	ND	4.7 E-02
624-64-6	trans-Butene	ND	ND	4.7 E-02
107-00-6	1-Butyne	ND	ND	4.5 E-02
503-17-3	2-Butyne	ND	ND	4.5 E-02
7440-44-0	Elemental carbon <sup>g</sup>	ND	ND	3.2 E-02
7440-44-0	Organic carbon <sup>f</sup>	4.3 E-06	6.6 E-04	--
7440-44-0	Total carbon <sup>f</sup>	4.3 E-06	6.6 E-04	--
39638-32-9	bis(2-Chloroisopropyl)ether	ND	ND	1.7 E-02
59-50-7	4-Chloro-3-methylphenol	ND	ND	1.7 E-02
124-48-1	Dibromochloromethane	ND	ND	1.7 E-03
156-59-2	cis-1,2-Dichloroethene	ND	ND	8.1 E-04
156-60-5	trans-1,2-Dichloroethene	ND	ND	8.1 E-04
10061-01-5	cis-1,3-Dichloropropene	ND	ND	9.2 E-04
84-66-2	Diethylphthalate	ND	ND	1.7 E-02
5779-94-2	2,5-Dimethylbenzaldehyde	ND	ND	7.6 E-03
117-84-0	Di-n-octylphthalate	ND	ND	1.7 E-02
74-84-0	Ethane <sup>g</sup>	ND	ND	2.5 E-02
141-78-6	Ethyl acetate	ND	ND	7.3 E-04
97-63-2	Ethyl methacrylate	ND	ND	9.5 E-04
622-96-8	4-Ethyltoluene <sup>g</sup>	ND	ND	1.0 E-03
142-82-5	n-Heptane	ND	ND	8.3 E-04
66-25-1	Hexaldehyde	ND	ND	7.6 E-03
591-78-6	2-Hexanone	ND	ND	2.1 E-03
2691-41-0	HMX	ND	ND	1.3 E-03
10035-10-6	Hydrogen bromide	ND	ND	1.2 E-01
75-28-5	Isobutane	ND	ND	4.8 E-02
115-11-7	Isobutylene	ND	ND	4.7 E-02
590-86-3	Isovaleraldehyde	ND	ND	7.6 E-03
78-93-3	Methyl ethyl ketone <sup>g</sup>	ND	ND	1.5 E-03
98-83-9	alpha-Methylstyrene	ND	ND	9.8 E-04
479-45-8	Methyl-2,4,6-trinitrophenylnitramine	ND	ND	6.5 E-04



TABLE A5 (cont.)

CASRN <sup>a</sup>	Compound	Emission Factor <sup>b,c</sup>		Minimum Detection Level mg/m <sup>3,e</sup>
		lb per item	lb per lb NEW <sup>d</sup>	
88-74-7	2-Nitroaniline	ND	ND	1.7 E-02
99-09-2	3-Nitroaniline	ND	ND	1.7 E-02
88-72-2	2-Nitrotoluene	ND	ND	6.5 E-04
99-08-1	3-Nitrotoluene	ND	ND	6.5 E-04
99-99-0	4-Nitrotoluene	ND	ND	6.5 E-04
111-65-9	Octane	ND	ND	9.5 E-04
78-11-5	Pentaerythritol tetranitrate	ND	ND	1.3 E-03
109-66-0	Pentane	ND	ND	6.0 E-02
14797-73-0	Perchlorate	ND	ND	7.1 E-02
7664-38-2	Phosphoric acid	ND	ND	1.1 E-01
74-98-6	Propane	ND	ND	3.7 E-02
115-11-7	1-Propene, 2-methyl	ND	ND	4.7 E-02
74-99-7	Propyne	ND	ND	3.3 E-02
121-82-4	RDX	1.2 E-07	1.8 E-05	--
1334-78-7	o,m,p-Tolualdehyde	ND	ND	2.3 E-02
25323-89-1	Trichloroethane	ND	ND	9.9 E-04
108-67-8	1,3,5-Trimethylbenzene	ND	ND	1.0 E-03
99-35-4	1,3,5-Trinitrobenzene	ND	ND	6.5 E-04
118-96-7	2,4,6-Trinitrotoluene <sup>g</sup>	ND	ND	6.5 E-04
110-62-3	Valeraldehyde	ND	ND	7.6 E-03

<sup>a</sup> CASRN = Chemical Abstracts Service Registry Number.

<sup>b</sup> ND = nondetected.

<sup>c</sup> Emission factors rated C unless otherwise noted.

<sup>d</sup> NEW = Net explosive weight. The NEW for this compound is 6.56 E-03 pounds per item.

<sup>e</sup> Data provided for compounds that were not detected.

<sup>f</sup> Emission factor rated A because of correlation with emission factors for similar ordnance and number of test data points.

<sup>g</sup> Emission factor rated B because of correlation with emission factors for similar ordnance and number of test data points.

<sup>h</sup> Emission factor rated D because the factor is based upon C-rated test data.

<sup>i</sup> Emission factor rated D because the factor is for a tentatively identified compound.

This page left blank intentionally.

DRAFT

## **APPENDIX B**

### **NEW AP-42 SECTIONS FOR ORDNANCE INCLUDED IN FIRING POINT EMISSION STUDY PHASE II SERIES 10 TESTING AT ABERDEEN PROVING GROUND, MARYLAND**

Electronic versions of the new AP-42 sections for ordnance included in Firing Point Emission Study Phase II Series 10 testing at Aberdeen Proving Ground, Maryland, are located on the EPA website at: <http://www.epa.gov/ttn/chief/ap42/index.html>.

This page left blank intentionally.