

AIR

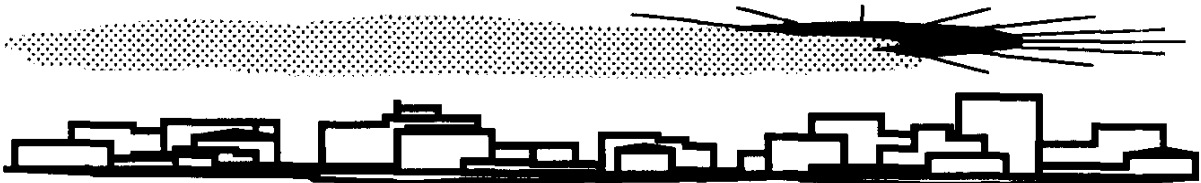

# LOCATING AND ESTIMATING AIR EMISSIONS FROM SOURCES OF CADMIUM AND CADMIUM COMPOUNDS



# L & E

# **Locating and Estimating Air Emissions From Sources of Cadmium and Cadmium Compounds**

U. S. Environmental Protection Agency  
Office of Air and Radiation  
Office of Air Quality Planning and Standards

# Locating and Estimating Air Emissions From Sources of Cadmium and Cadmium Compounds

Prepared for:

Anne Pope  
Office of Air Quality Planning and Standards  
Technical Support Division  
U. S. Environmental Protection Agency  
Research Triangle Park, N.C. 27711

Prepared by:

Midwest Research Institute  
401 Harrison Oaks Boulevard, Suite 350  
Cary, North Carolina 27513

TABLE OF CONTENTS

| <u>Section</u> | <u>Page</u>   |
|----------------|---|
| 1              | PURPOSE OF DOCUMENT . . . . . 1-1                           |
|                | REFERENCES . . . . . 1-4                                    |
| 2              | OVERVIEW OF DOCUMENT CONTENTS . . . . . 2-1                 |
| 3              | BACKGROUND . . . . . 3-1                                    |
|                | NATURE OF POLLUTANT . . . . . 3-1                           |
|                | OVERVIEW OF PRODUCTION, USE, AND EMISSIONS . . . . . 3-4    |
|                | Production . . . . . 3-4                                    |
|                | Use . . . . . 3-6   |
|                | Emissions . . . . . 3-6                                     |
|                | REFERENCES . . . . . 3-13                                   |
| 4              | EMISSIONS FROM CADMIUM PRODUCTION . . . . . 4-1             |
|                | CADMIUM REFINING AND CADMIUM OXIDE PRODUCTION . . . . . 4-1 |
|                | Process Description . . . . . 4-3                           |
|                | Emissions and Controls . . . . . 4-6                        |
|                | CADMIUM PIGMENTS PRODUCTION . . . . . 4-11                  |
|                | Process Description . . . . . 4-14                          |
|                | Emissions and Controls . . . . . 4-19                       |
|                | CADMIUM STABILIZERS PRODUCTION . . . . . 4-20               |
|                | Process Description . . . . . 4-22                          |
|                | Emission and Controls . . . . . 4-24                        |
|                | OTHER CADMIUM COMPOUND PRODUCTION . . . . . 4-25            |
|                | Process Descriptions . . . . . 4-25                         |
|                | Emissions and Controls . . . . . 4-29                       |
|                | REFERENCES . . . . . 4-32                                   |
| 5              | EMISSIONS FROM MAJOR USES OF CADMIUM . . . . . 5-1          |
|                | CADMIUM ELECTROPLATING . . . . . 5-1                        |
|                | Process Description . . . . . 5-2                           |
|                | Emission Control . . . . . 5-6                              |
|                | Emissions . . . . . 5-7                                     |
|                | SECONDARY BATTERY MANUFACTURE . . . . . 5-7                 |
|                | Process Description . . . . . 5-9                           |
|                | Emission Control Measures . . . . . 5-13                    |
|                | Emissions . . . . . 5-13                                    |
|                | CADMIUM STABILIZERS FOR PLASTICS . . . . . 5-14             |
|                | Process Description . . . . . 5-16                          |
|                | Emission Control Measures . . . . . 5-17                    |
|                | Emissions . . . . . 5-18                                    |
|                | CADMIUM PIGMENTS IN PLASTICS . . . . . 5-18                 |
|                | Process Description . . . . . 5-20                          |
|                | Emission Control Measures . . . . . 5-22                    |
|                | Emissions . . . . . 5-22                                    |
|                | REFERENCES . . . . . 5-23                                   |

TABLE OF CONTENTS (continued)

|   |  |      |
|---|--|------|
| 6 | EMISSIONS FROM COMBUSTION SOURCES . . . . .                          | 6-1  |
|   | COAL COMBUSTION . . . . .  | 6-5  |
|   | Coal Characteristics . . . . .                                       | 6-6  |
|   | Process Description . . . . .  | 6-10 |
|   | Emission Control Measures . . . . .                                  | 6-15 |
|   | Emissions . . . . .  | 6-16 |
|   | FUEL OIL COMBUSTION . . . . .  | 6-20 |
|   | Fuel Oil Characteristics . . . . .                                   | 6-22 |
|   | Process Description . . . . .  | 6-23 |
|   | Emission Control Measures . . . . .                                  | 6-27 |
|   | Emissions . . . . .  | 6-28 |
|   | NATURAL GAS COMBUSTION . . . . .                                     | 6-33 |
|   | Natural Gas Characteristics . . . . .                                | 6-33 |
|   | Process Description . . . . .  | 6-34 |
|   | Emission Control Measures . . . . .                                  | 6-34 |
|   | Emissions . . . . .  | 6-34 |
|   | WOOD COMBUSTION . . . . .  | 6-35 |
|   | Process Description . . . . .  | 6-35 |
|   | Emission Control Measures . . . . .                                  | 6-37 |
|   | Emissions . . . . .  | 6-39 |
|   | MUNICIPAL WASTE COMBUSTION . . . . .                                 | 6-40 |
|   | Municipal Solid Waste Characteristics . . . . .                      | 6-42 |
|   | Process Description . . . . .  | 6-42 |
|   | Emission Control Measures . . . . .                                  | 6-48 |
|   | Emissions . . . . .  | 6-50 |
|   | SEWAGE SLUDGE INCINERATORS . . . . .                                 | 6-51 |
|   | Process Description . . . . .  | 6-54 |
|   | Emission Control Measures . . . . .                                  | 6-58 |
|   | Emissions . . . . .  | 6-59 |
|   | MEDICAL WASTE INCINERATION . . . . .                                 | 6-61 |
|   | Process Description . . . . .  | 6-62 |
|   | Emission Control Measures . . . . .                                  | 6-67 |
|   | Emissions . . . . .  | 6-68 |
|   | REFERENCES . . . . .   | 6-75 |
| 7 | EMISSIONS FROM NONFERROUS SMELTING/REFINING . . . . .                | 7-1  |
|   | PRIMARY LEAD SMELTING . . . . .                                      | 7-1  |
|   | Process Description . . . . .  | 7-2  |
|   | Emission Control Measures . . . . .                                  | 7-4  |
|   | Emissions . . . . .  | 7-5  |
|   | PRIMARY COPPER SMELTING . . . . .                                    | 7-7  |
|   | Process Description . . . . .  | 7-8  |
|   | Emission Control Measures . . . . .                                  | 7-13 |
|   | Emissions . . . . .  | 7-14 |
|   | PRIMARY ZINC SMELTING AND REFINING . . . . .                         | 7-15 |
|   | Process Description - Electrolytic . . . . .                         | 7-17 |
|   | Process Description--Pyrometallurgical<br>(Electrothermic) . . . . . | 7-22 |
|   | Emission Control Measures . . . . .                                  | 7-23 |
|   | Emissions . . . . .  | 7-24 |

TABLE OF CONTENTS (continued)

|   |   |      |
|---|---|------|
|   | SECONDARY COPPER SMELTING AND REFINING . . . . .  | 7-25 |
|   | Process Description . . . . .   | 7-26 |
|   | Emission Control Measures . . . . .   | 7-31 |
|   | Emissions . . . . .   | 7-33 |
|   | SECONDARY ZINC RECOVERY FROM METALLIC SCRAP . . . . .   | 7-34 |
|   | Process Description . . . . .   | 7-34 |
|   | Emission Control Measures . . . . .   | 7-39 |
|   | Emissions . . . . .   | 7-41 |
|   | SECONDARY ZINC RECOVERY FROM STEEL PRODUCTION . . . . .   | 7-41 |
|   | Process Description . . . . .   | 7-43 |
|   | Emission Control Measures . . . . .   | 7-48 |
|   | Emissions . . . . .   | 7-48 |
|   | REFERENCES . . . . .  | 7-49 |
| 8 | EMISSIONS FROM MISCELLANEOUS SOURCES . . . . .  | 8-1  |
|   | IRON AND STEEL PRODUCTION . . . . .   | 8-1  |
|   | Process Description . . . . .   | 8-4  |
|   | Emission Control Measures . . . . .   | 8-10 |
|   | Emissions . . . . .   | 8-12 |
|   | PORTLAND CEMENT MANUFACTURING . . . . .   | 8-12 |
|   | Process Description . . . . .   | 8-15 |
|   | Emission Control Measures . . . . .   | 8-18 |
|   | Emissions . . . . .   | 8-20 |
|   | PHOSPHATE ROCK PROCESSING . . . . .   | 8-20 |
|   | Process Description . . . . .   | 8-23 |
|   | Emission Control Measures . . . . .   | 8-25 |
|   | Emissions . . . . .   | 8-26 |
|   | CARBON BLACK PRODUCTION . . . . .   | 8-27 |
|   | Process Description . . . . .   | 8-29 |
|   | Emission Control Measures . . . . .   | 8-31 |
|   | Emissions . . . . .   | 8-31 |
|   | MOBILE SOURCES . . . . .  | 8-32 |
|   | REFERENCES . . . . .  | 8-33 |
| 9 | SOURCE TEST PROCEDURES . . . . .  | 9-1  |
|   | INTRODUCTION . . . . .  | 9-1  |
|   | MULTIPLE METALS SAMPLING TRAINS . . . . .   | 9-2  |
|   | Method 0012-Methodology for the Determination of Metals Emissions in Exhaust Gases from Hazardous Waste Incineration and Similar Combustion Sources . . . . . | 9-2  |
|   | Methodology for the Determination of Metals Emissions in Exhaust Gases from Hazardous Waste Incineration and Similar Combustion Sources . . . . .             | 9-4  |
|   | CARB Method 436-Determination of Multiple Metals Emissions from Stationary Sources . . . . .  | 9-4  |
|   | EPA Method 29-Methodology for the   |      |

TABLE OF CONTENTS (continued)

Determination of Metals Emissions in  
Exhaust Gases from Incineration and  
Similar Combustion Sources (Draft) . . . . . 9-5  
ANALYTICAL METHODS FOR DETERMINATION OF CADMIUM . . . 9-5  
    Flame AAS . . . . . 9-6  
    Graphite Furnace AAS . . . . . 9-6  
    Hydride AA . . . . . 9-6  
    Cold-Vapor AA . . . . . 9-7  
SUMMARY . . . . . 9-7  
REFERENCES . . . . . 9-9

APPENDIX A - NATIONWIDE EMISSION ESTIMATES . . . . . A-1

APPENDIX B - SUMMARY OF COMBUSTION SOURCE CADMIUM  
EMISSION DATA . . . . . B-1

APPENDIX C - PLANT LOCATIONS AND ANNUAL CAPACITIES FOR  
MISCELLANEOUS EMISSIONS SOURCES . . . . . C-1

LIST OF FIGURES

| <u>Figure</u>   | <u>Page</u> |
|---|-------------|
| 3-1 1991 supply and demand for cadmium . . . . .  | 3-5         |
| 3-2 End use pattern of cadmium . . . . .  | 3-7         |
| 4-1 Flow diagram for cadmium refining . . . . .   | 4-4         |
| 4-2 Process flowsheet for the production of<br>cadmium pigments . . . . .                         | 4-17        |
| 4-3 General flowsheet for the production of<br>powdered cadmium stabilizers. . . . .              | 4-23        |
| 5-1 Cadmium electroplating process. . . . .   | 5-4         |
| 5-2 Simplified flow diagram for production of sintered<br>plate nickel-cadmium batteries. . . . . | 5-11        |
| 6-1 Distribution of sewage sludge incinerators in the<br>United States . . . . .                  | 6-53        |
| 6-2 Process flow diagram for sludge incineration . . . . .  | 6-55        |
| 6-3 Major components of an incineration system. . . . .   | 6-64        |
| 7-1 Typical primary lead-processing scheme . . . . .  | 7-3         |
| 7-2 Typical primary copper-smelting process. . . . .  | 7-9         |
| 7-3 Typical primary zinc-smelting process. . . . .  | 7-18        |
| 7-4 Process flow diagram for second-grade<br>copper recovery. . . . .                             | 7-28        |
| 7-5 Process flow diagram for high-grade<br>brass and bronze alloying. . . . .                     | 7-29        |
| 7-6 Process flow diagram for secondary zinc processing . .  | 7-36        |
| 7-7 Process flow diagram for Waelz kiln process. . . . .  | 7-45        |
| 7-8 Process flow diagram for zinc calcine formation. . . .  | 7-47        |
| 8-1 General flow diagram for the iron and steel industry . .                                      | 8-5         |
| 8-2 Process flow diagram of Portland cement<br>manufacturing process . . . . .                    | 8-16        |
| 8-3 Typical flowsheet for processing phosphate rock . . .   | 8-24        |



LIST OF FIGURES (continued)

|      |  |      |
|------|--|------|
| 8-4  | Process flow diagram for carbon black<br>manufacturing process . . . . . | 8-30 |
| 9-1. | Typical multiple metals sampling train . . . . .                         | 9-3  |

LIST OF TABLES

| <u>Table</u>  | <u>Page</u> |
|---|-------------|
| 3-1 PHYSICAL PROPERTIES OF CADMIUM . . . . .  | 3-2         |
| 3-2 SIC CODES OF INDUSTRIES ASSOCIATED WITH<br>CADMIUM EMISSIONS . . . . .  | 3-10        |
| 3-3 ESTIMATED 1990 NATIONWIDE CADMIUM EMISSIONS FOR<br>SELECTED SOURCE CATEGORIES . . . . .   | 3-12        |
| 4-1 CADMIUM AND CADMIUM OXIDE PRODUCERS . . . . .   | 4-2         |
| 4-2 INVENTORY OF CADMIUM EMISSION SOURCES AND<br>CONTROLS FOR CADMIUM REFINING PLANTS . . . . .                                     | 4-7         |
| 4-3 PRIMARY ZINC AND CADMIUM PRODUCERS REPORTING CADMIUM<br>EMISSIONS IN THE 1990 TOXIC CHEMICALS<br>RELEASE INVENTORY . . . . .    | 4-10        |
| 4-4 CADMIUM EMISSION FACTORS FOR CADMIUM REFINING<br>PLANT USING LEAD BLAST FURNACE DUST . . . . .                                  | 4-12        |
| 4-5 EMISSION FACTORS FOR CADMIUM AND CADMIUM<br>OXIDE PRODUCTION . . . . .  | 4-13        |
| 4-6 COMMON CADMIUM PIGMENTS PRODUCED IN 1991 . . . . .  | 4-15        |
| 4-7 CURRENT CADMIUM PIGMENT PRODUCERS . . . . .   | 4-16        |
| 4-8 INORGANIC PIGMENTS MANUFACTURERS REPORTING CADMIUM<br>EMISSIONS IN THE 1990 TOXIC CHEMICALS<br>RELEASE INVENTORY . . . . .      | 4-21        |
| 4-9 MANUFACTURERS OF ORGANIC COMPOUNDS REPORTING CADMIUM<br>EMISSIONS IN THE 1990 TOXIC CHEMICALS<br>RELEASE INVENTORY . . . . .    | 4-26        |
| 4-10 CADMIUM COMPOUND MANUFACTURERS (OTHER THAN<br>CADMIUM OXIDE, PIGMENTS, AND STABILIZERS) . . . . .                              | 4-27        |
| 4-11 CADMIUM COMPOUND MANUFACTURERS (OTHER THAN CADMIUM<br>OXIDE, PIGMENTS, AND STABILIZERS) . . . . .                              | 4-30        |
| 4-12 MANUFACTURERS OF INORGANIC COMPOUNDS REPORTING CADMIUM<br>EMISSIONS IN THE 1990 TOXIC CHEMICALS<br>RELEASE INVENTORY . . . . . | 4-31        |
| 5-1 MARKET AREAS FOR CADMIUM COATINGS . . . . .   | 5-3         |
| 5-2 COMPOSITION AND OPERATING PARAMETERS OF CADMIUM<br>CYANIDE PLATING BATH . . . . .   | 5-6         |

LIST OF TABLES (continued)

|      |   |      |
|------|---|------|
| 5-3  | NICKEL-CADMIUM BATTERY PRODUCERS--1990 . . . . .  | 5-9  |
| 5-4  | REPORTED CADMIUM EMISSIONS BY MANUFACTURERS OF<br>FORMULATED RESINS AND PLASTIC PRODUCTS . . . . .        | 5-19 |
| 5-5  | REPORTED CADMIUM EMISSIONS BY PRODUCERS OF<br>CUSTOM COMPOUNDED RESINS . . . . .                          | 5-21 |
| 6-1  | DISTRIBUTION OF FOSSIL FUEL CONSUMPTION IN THE<br>UNITED STATES . . . . .                                 | 6-3  |
| 6-2  | COAL HEATING VALUES . . . . .   | 6-7  |
| 6-3  | EXAMPLES OF COAL HEAT CONTENT VARIABILITY . . . . .   | 6-8  |
| 6-4  | CADMIUM CONCENTRATION IN COAL BY COAL TYPE . . . . .  | 6-11 |
| 6-5  | CADMIUM CONCENTRATION IN COAL BY REGION . . . . .   | 6-11 |
| 6-6  | CALCULATED UNCONTROLLED CADMIUM EMISSION FACTORS<br>FOR COAL COMBUSTION . . . . .                         | 6-18 |
| 6-7  | SUMMARY OF CADMIUM EMISSION FACTORS FOR<br>COAL COMBUSTION . . . . .                                      | 6-19 |
| 6-8  | BEST TYPICAL CADMIUM EMISSION FACTORS FOR<br>COAL COMBUSTION . . . . .                                    | 6-21 |
| 6-9  | TYPICAL HEATING VALUES OF FUEL OILS . . . . .   | 6-24 |
| 6-10 | TYPICAL FUEL OIL HEATING VALUES FOR<br>SPECIFIC REGIONS . . . . .   | 6-25 |
| 6-11 | CADMIUM CONCENTRATION IN OIL BY OIL TYPE . . . . .  | 6-26 |
| 6-12 | CALCULATED UNCONTROLLED CADMIUM EMISSION FACTORS<br>FOR FUEL OIL COMBUSTION . . . . .                     | 6-29 |
| 6-13 | MEASURED CADMIUM EMISSION FACTORS FOR FUEL<br>OIL COMBUSTION . . . . .                                    | 6-30 |
| 6-14 | CADMIUM EMISSION FACTORS FOR FUEL OIL COMBUSTION<br>GENERATED FROM CALIFORNIA "HOT SPOTS" TESTS . . . . . | 6-32 |
| 6-15 | BEST TYPICAL CADMIUM EMISSION FACTORS FOR FUEL OIL<br>COMBUSTION . . . . .                                | 6-33 |
| 6-16 | SUMMARY OF CADMIUM EMISSION FACTORS FOR<br>WOOD COMBUSTION . . . . .                                      | 6-39 |

LIST OF TABLES (continued)

|      |  |      |
|------|--|------|
| 6-17 | SUMMARY OF GEOGRAPHICAL DISTRIBUTION OF<br>MWC FACILITIES . . . . .  | 6-41 |
| 6-18 | CURRENT AND FORECAST COMPOSITION OF<br>DISPOSED RESIDENTIAL<br>AND COMMERCIAL WASTE (WEIGHT PERCENT) . . . . .         | 6-43 |
| 6-19 | BEST TYPICAL CADMIUM EMISSION FACTORS FOR MUNICIPAL<br>WASTE COMBUSTORS . . . . .                                      | 6-52 |
| 6-20 | SUMMARY OF CADMIUM EMISSION FACTORS FOR<br>SEWAGE SLUDGE INCINERATION . . . . .  | 6-60 |
| 6-21 | UNCONTROLLED CADMIUM EMISSION FACTORS FOR<br>MEDICAL WASTE INCINERATORS . . . . .                                      | 6-70 |
| 6-22 | SUMMARY OF CONTROLLED CADMIUM EMISSION FACTORS<br>AND CONTROL EFFICIENCIES FOR MEDICAL<br>WASTE INCINERATORS . . . . . | 6-73 |
| 6-23 | BEST TYPICAL UNCONTROLLED CADMIUM EMISSION<br>FACTORS FOR MEDICAL WASTE INCINERATORS . . . . .                         | 6-74 |
| 7-1  | DOMESTIC PRIMARY LEAD SMELTERS AND REFINERIES . . . . .  | 7-2  |
| 7-2  | PRIMARY LEAD PRODUCERS REPORTING CADMIUM EMISSIONS<br>IN THE 1990 TOXICS RELEASE INVENTORY . . . . .                   | 7-5  |
| 7-3  | CADMIUM EMISSION FACTORS FOR LEAD-SMELTING<br>FACILITIES . . . . .   | 7-6  |
| 7-4  | DOMESTIC PRIMARY COPPER SMELTERS AND REFINERIES . . . . .  | 7-7  |
| 7-5  | PRIMARY COPPER PRODUCERS REPORTING CADMIUM EMISSIONS<br>IN THE 1990 TOXICS RELEASE INVENTORY . . . . .                 | 7-14 |
| 7-6  | CADMIUM EMISSIONS FROM PRIMARY COPPER PRODUCTION . . . . .   | 7-16 |
| 7-7  | DOMESTIC PRIMARY ZINC PRODUCERS . . . . .  | 7-17 |
| 7-8  | PRIMARY ZINC PRODUCERS REPORTING CADMIUM EMISSIONS<br>IN THE 1990 TOXICS RELEASE INVENTORY . . . . .                   | 7-24 |
| 7-9  | CADMIUM EMISSIONS FROM PRIMARY ZINC PRODUCTION . . . . .   | 7-25 |
| 7-10 | DOMESTIC SECONDARY COPPER PRODUCERS . . . . .  | 7-26 |
| 7-11 | SECONDARY COPPER PRODUCERS REPORTING<br>CADMIUM EMISSIONS IN THE 1989 AND 1990<br>TOXICS RELEASE INVENTORY . . . . .   | 7-34 |

LIST OF TABLES (continued)

|      |  |      |
|------|--|------|
| 7-12 | DOMESTIC PRODUCERS OF SECONDARY ZINC FROM METALLIC SCRAP . . . . .                                       | 7-35 |
| 7-13 | CADMIUM EMISSIONS FROM SECONDARY ZINC RECOVERY FROM METAL SCRAP . . . . .                                | 7-42 |
| 7-14 | DOMESTIC PRODUCERS OF SECONDARY ZINC FROM EAF DUST . . . . .   | 7-44 |
| 8-1  | INTEGRATED IRON AND STEEL PLANTS . . . . .   | 8-3  |
| 8-2  | COKE PRODUCTION CAPACITY FOR INTEGRATED IRON AND STEEL FACILITIES IN THE UNITED STATES IN 1991 . . . . . | 8-6  |
| 8-3  | CADMIUM RELEASES REPORTED BY IRON AND STEEL FACILITIES IN 1990 TRI . . . . .                             | 8-13 |
| 8-4  | CADMIUM EMISSIONS REPORTED FROM BETHLEHEM STEEL, SPARROWS POINT, MARYLAND . . . . .                      | 8-14 |
| 8-5  | CADMIUM EMISSION FACTORS FROM PORTLAND CEMENT FACILITIES . . . . .                                       | 8-21 |
| 8-6  | CARBON BLACK PRODUCTION FACILITIES . . . . .   | 8-28 |
| 9-1  | CADMIUM SAMPLING METHODS . . . . .   | 9-8  |

SECTION 1  
PURPOSE OF DOCUMENT

The U. S. Environmental Protection Agency (EPA), State, and local air pollution control agencies are becoming increasingly aware of the presence of substances in the ambient air that may be toxic at certain concentrations. This awareness, in turn, has led to attempts to identify source/receptor relationships for these substances and to develop control programs to regulate emissions. Unfortunately, little information exists on the ambient air concentration of these substances or about the sources that may be discharging them to the atmosphere.

To assist groups interested in inventorying air emissions of various potentially toxic substances, EPA is preparing a series of documents such as this that compiles available information on sources and emissions of these substances. Prior documents in the series are listed below:

| <u>Substance</u>     | <u>EPA<br/>Publication Number</u> |
|----------------------|-----------------------------------|
| Acrylonitrile        | EPA-450/4-84-007a                 |
| Carbon Tetrachloride | EPA-450/4-84-007b                 |
| Chloroform           | EPA-450/4-84-007c                 |
| Ethylene Dichloride  | EPA-450/4-84-007d                 |
| Formaldehyde         | EPA-450/4-91-012                  |
| Nickel               | EPA-450/4-84-007f                 |
| Chromium             | EPA-450/4-84-007g                 |
| Manganese            | EPA-450/4-84-007h                 |
| Phosgene             | EPA-450/4-84-007i                 |
| Epichlorohydrin      | EPA-450/4-84-007j                 |
| Vinylidene Chloride  | EPA-450/4-84-007k                 |
| Ethylene Oxide       | EPA-450/4-84-007l                 |

|  |                   |
|--|-------------------|
| Chlorobenzene                              | EPA-450/4-84-007m |
| Polychlorinated Biphenyls (PCB's)          | EPA-450/4-84-007n |
| Polycyclic Organic Matter (POM)            | EPA-450/4-84-007p |
| Benzene                                    | EPA-450/4-84-007q |
| Perchloroethylene and<br>Trichloroethylene | EPA-450/2-89-013  |
| Municipal Waste Combustion                 | EPA-450/2-89-006  |
| Coal and Oil Combustion                    | EPA-450/2-89-001  |
| 1,3-Butadiene                              | EPA-450/2-89-021  |
| Chromium (Supplement)                      | EPA-450/2-89-002  |
| Sewage Sludge                              | EPA-450/2-90-009  |
| Styrene                                    | EPA-450/4-91-029  |

This document deals specifically with cadmium and cadmium compounds; however, the majority of the information contained in this document concerns cadmium. Sources of cadmium emissions evaluated in this document include: (1) cadmium production and use processes; (2) emissions from combustion sources; (3) production of other nonferrous metals where cadmium emissions result as inadvertent byproducts of the process; (4) production processes for selected materials other than nonferrous metals; and (5) mobile sources.

In addition to the information presented in this document, another potential source of emissions data for cadmium and cadmium compounds is the Toxic Chemical Release Inventory (TRI) form required by Section 313 of Title III of the 1986 Superfund Amendments and Reauthorization Act (SARA 313).<sup>1</sup> SARA 313 requires owners and operators of facilities in certain Standard Industrial Classification Codes that manufacture, import, process or otherwise use toxic chemicals (as listed in Section 313) to report annually their releases of these chemicals to all environmental media. As part of SARA 313, EPA provides public access to the annual emissions data. The TRI data include general facility information, chemical information, and emissions data. Air emissions data are reported as total facility release

estimates for fugitive emissions and point source emissions. No individual process or stack data are provided to EPA under the program. The TRI requires sources to use stack monitoring data for reporting, if available, but the rule does not require stack monitoring or other measurement of emissions if it is unavailable. If monitoring data are unavailable, emissions are to be quantified based on best estimates of releases to the environment.

The reader is cautioned that the TRI will not likely provide facility, emissions, and chemical release data sufficient for conducting detailed exposure modeling and risk assessment. In many cases, the TRI data are based on annual estimates of emissions (i.e., on emission factors, material balance calculations, and engineering judgment). We recommend the use of TRI data in conjunction with the information provided in this document to locate potential emitters of cadmium and to make preliminary estimates of air emissions from these facilities.

Cadmium is of particular importance as a result of the Clean Air Act Amendments of 1990. Cadmium and its compounds are included in the Title III list of hazardous air pollutants and will be subject to standards established under Section 112, including maximum achievable control technology (MACT). Also, Section 112(c)(6) of the 1990 Amendments mandate that cadmium (among others) be subject to standards that allow for the maximum degree of reduction of emissions. These standards are to be promulgated no later than 10 years following the date of enactment.

The data on cadmium emissions are based, whenever possible, on the results of actual test procedures. Data presented in this document are total cadmium emissions and do not differentiate the metallic and ionic forms of cadmium. The sampling and analysis



procedures employed for the determination of the cadmium concentrations from various sources are presented in Section 9, Source Test Method.

REFERENCES FOR SECTION 1

1. Toxic Chemical Release Reporting: Community Right-To-Know.  
Federal Register 52(107): 21152-21208. June 4, 1987.

## SECTION 2

### OVERVIEW OF DOCUMENT CONTENTS

As noted in Section 1, the purpose of this document is to assist Federal, State, and local air pollution agencies and others who are interested in locating potential air emitters of cadmium and cadmium compounds and estimating air emissions from these sources. Because of the limited background data available, the information summarized in this document does not and should not be assumed to represent the source configuration or emissions associated with any particular facility.

This section provides an overview of the contents of this document. It briefly outlines the nature, extent, and format of the material presented in the remaining sections of this document.

Section 3 of this document provides a brief summary of the physical and chemical characteristics of cadmium and cadmium compounds and an overview of their production and uses. A chemical use tree summarizes the quantities of cadmium produced as well as the relative amounts consumed by various end uses. This background section may be useful to someone who wants to develop a general perspective on the nature of the substance and where it is manufactured and consumed.

Sections 4 to 7 of this document focus on the major industrial source categories that may discharge cadmium-containing air emissions. Section 4 discusses the production of

cadmium and cadmium compounds. Section 5 discusses the different major uses of cadmium as an industrial feedstock. Section 6 discusses emissions from combustion sources. Section 7 discusses emissions from selected nonferrous smelting/refining processes, and Section 8 discusses emissions from miscellaneous production processes and mobile sources. For each major industrial source category described, process descriptions and flow diagrams are given wherever possible, potential emission points are identified, and available emission factor estimates are presented that show the potential for cadmium emissions before and after controls are employed by industry. Individual companies are named that are reported to be involved with the production and/or use of cadmium based on industry contacts, the Toxic Release Inventory (TRI), and available trade publications.

The final section of this document summarizes available procedures for source sampling and analysis of cadmium. Details are not prescribed nor is any EPA endorsement given or implied for any of these sampling and analysis procedures. Appendix A presents calculations used to derive the estimated 1990 nationwide cadmium emissions. Appendix B presents a summary of the combustion source test data. Appendix C lists names and locations of electric arc furnaces, U.S. Portland cement manufacturers, phosphate rock processors, and elemental phosphorus producers.

This document does not contain any discussion of health or other environmental effects of cadmium, nor does it include any discussion of ambient air levels or ambient air monitoring techniques.

Comments on the content or usefulness of this document are welcome, as is any information on process descriptions, operating

practices, control measures, and emissions that would enable EPA to improve its contents. All comments should be sent to:

Chief, Emission Factor and Methodology Section (MD-14)  
Emission Inventory Branch  
U. S. Environmental Protection Agency  
Research Triangle Park, NC 27711

## SECTION 3

### BACKGROUND

This section discusses cadmium and its compounds and alloys, their chemical and physical properties, and their commercial uses. The section also provides statistics on cadmium production and use. Finally, the section presents nationwide estimates of cadmium emissions from the sources discussed in the other sections of this document.

#### NATURE OF POLLUTANT

Cadmium is a soft, ductile, silvery-white metal. It was discovered by Stromeyer in 1817 as an impurity in zinc carbonate. Table 3-1 summarizes cadmium's chemical and physical properties.

When heated in air, cadmium forms a fume of brown-colored cadmium oxide, CdO. Other elements which react readily with cadmium metal upon heating include the halogens, phosphorus, selenium, and tellurium. The metal is not attacked by aqueous solutions of alkali hydroxides.

Cadmium is slowly attacked by warm dilute hydrochloric or sulfuric acid with the evolution of hydrogen but is rapidly oxidized to the cadmium ion by hot dilute nitric acid with evolution of various oxides of nitrogen (NO<sub>x</sub>). Cadmium is displaced from solution by more electropositive metals such as

TABLE 3-1. PHYSICAL PROPERTIES OF CADMIUM

| Property  | Value         |
|---|---------------|
| Atomic weight   | 112.41        |
| Crystal structure   | Hexagonal     |
| CAS registry number   | 7440-43-9     |
| Atomic number   | 48            |
| Valence   | 2             |
| Outer electron configuration                                    | $4d^{10}5s^2$ |
| Metallic radius, Å  | 1.54          |
| Covalent radius, Å  | 1.48          |
| Electrode potential, normal, V<br>$Cd \rightarrow Cd^{2+} + 2e$ | -0.4013       |
| Melting point, °C   | 321.1         |
| Boiling, point, °C  | 767           |
| Latent heat of fusion, J/g (cal/g) <sup>a</sup>                 | 55.2 (13.2)   |
| Latent heat of vaporization, J/g (cal/g) <sup>a</sup>           | 886.9 (212)   |
| Specific heat, J/mol·K (cal/mol·K) <sup>a</sup>                 |               |
| Solid, 20°C   | 25.9 (6.19)   |
| Liquid, 321° to 700°C   | 29.7 (7.10)   |
| Electrical resistivity, $\mu\Omega\text{-cm}$                   |               |
| at 22°C   | 7.27          |
| at 400°C  | 34.1          |
| at 600°C  | 34.8          |
| at 700°C  | 35.8          |
| Density, kg/m <sup>3</sup>                                      |               |
| at 26°C   | 8,624         |
| at melting point  | 8,020         |
| at 400°C  | 7,930         |
| at 600°C  | 7,720         |
| Thermal conductivity, W (m·K), at 0°C                           | 98            |
| Vapor pressure, mmHg  |               |
| at 382°C  | 0.7598        |
| at 478°C  | 7.598         |
| at 595°C  | 75.98         |
| at 767°C  | 759.8         |

Source: Reference 1.

<sup>a</sup>To convert J to cal, divide by 4.184.

zinc or aluminum. The hydroxide of cadmium,  $\text{Cd}(\text{OH})_2$ , is virtually insoluble in alkaline media. The cadmium ion forms stable complexes with ammonia, as well as cyanide and halide ions.

Elemental cadmium is used primarily as an electroplated, corrosion resistant coating applied to iron, steel, brass, copper, and aluminum. Cadmium coatings are especially useful for protecting surfaces exposed to corrosive marine environments. An added advantage of using cadmium surface coatings is that cadmium is preferentially attacked by the corrosive environment and protects the base metal from corrosion. Even if the cadmium coating is slightly damaged, it continues to provide protection to the base metal.

Elemental cadmium coatings also have a low coefficient of friction, good electrical conductivity, are easily soldered, and have low volume corrosion products. The coatings reduce galvanic corrosion between steel and other metals, particularly aluminum.

Technically and commercially important cadmium compounds include the oxide, sulfide, selenide, chloride, sulfate, nitrate, hydroxide, and various organic cadmium salts of fatty acids, such as the palmitate and stearate. The only naturally occurring compound is the sulfide,  $\text{CdS}$  (greenockite), which is an accessory mineral in sulfide ores of lead, zinc, and copper and in sulfur-bearing coals.<sup>1,2</sup>

Cadmium forms alloys with many metals; these alloys fall into two major groups: those in which cadmium helps reduce the melting point and those in which cadmium improves mechanical properties.<sup>1,3,4</sup>



## OVERVIEW OF PRODUCTION, USE, AND EMISSIONS

This subsection summarizes cadmium production statistics, identifies industrial categories using cadmium, and provides estimates of nationwide cadmium emissions.

### Production

Primary production of cadmium occurs as a byproduct of smelting domestic and imported zinc concentrates and of recovery from lead smelter baghouse dust. There are four major producing companies in the U.S., and three produce the cadmium from smelting zinc concentrates. Only one company recovers cadmium from the lead smelter baghouse dust.<sup>5</sup>

Figure 3-1 presents the 1991 supply-and-demand diagram for cadmium. The information in this figure was obtained from the U.S. Bureau of Mines, Division of Mineral Commodities.<sup>5</sup> As shown in Figure 3-1, the total U.S. supply of cadmium was 4,368 Mg (4,805 tons). An estimated 38 percent of the total supply resulted from U.S. primary and secondary production processes, and 47 percent was the result of imports. The remaining 15 percent came from producer stockpiles. Figure 3-1 also shows that of the total 1991 U.S. cadmium supply, 74 percent was used to meet domestic demands, while 4 percent met export demands, and 22 percent supplied industry stocks. Exports of cadmium are in the form of cadmium metal and cadmium in alloys, dross, flue dust, residues, and scrap.<sup>5</sup>

The Bureau of Mines reported U.S. production of 329 Mg (362 tons) of cadmium sulfide (including lithopone and cadmium sulfoselenide) and 1,089 Mg (1,198 tons) of plating salts, cadmium oxide, and other compounds. The remaining 1,820 Mg (2,002 tons) of U.S. demand in 1991 apparently was comprised of

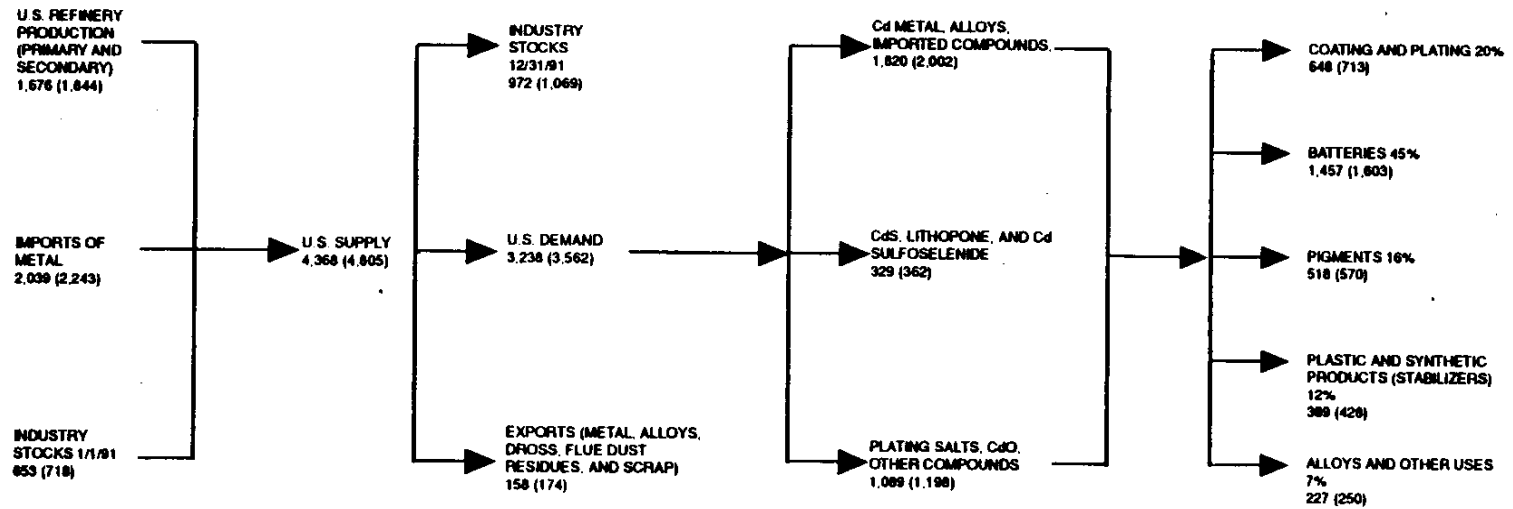

NOTE: ALL QUANTITIES ARE IN MEGAGRAMS (Mg); QUANTITIES IN PARENTHESES ARE IN TONS.

Figure 3-1. 1991 supply and demand for cadmium.

cadmium metal, alloys, and imported compounds.<sup>5</sup> The 1991 demand of 3,238 Mg (3,562 tons) shown in Figure 3-1 represents a slight increase over the 1990 demand level of 3,107 Mg (3,418 tons), but less than the 1989 demand levels of 4,096 Mg (4,506 tons).

### Use

The Bureau of Mines estimates that U.S. consumption of cadmium and cadmium compounds occurs principally in the following five areas:

1. Battery production;
2. Coatings and platings;
3. Pigments;
4. Plastic and synthetic products (primarily as stabilizers); and
5. Alloys and other products.

The estimated percentage of the total 1991 U.S. cadmium supply that was consumed by each end-use category is shown in Figure 3-2. Battery production, at 45 percent, accounts for the largest percentage of cadmium consumption (1,457 Mg/1,603 tons). Coating and plating operations were the next largest consumer at 20 percent (648 Mg/713 tons). The third and fourth largest consumer categories were pigments at 16 percent (518 Mg/570 tons) and plastic and synthetic products (presumed to be primarily stabilizers) at 12 percent (389 Mg/428 tons). The smallest end-use category was alloys and other uses at 7 percent (227 Mg/250 tons).

### Emissions

Two distinct methods were used to develop nationwide emission estimates for specific source categories. The first

3-7

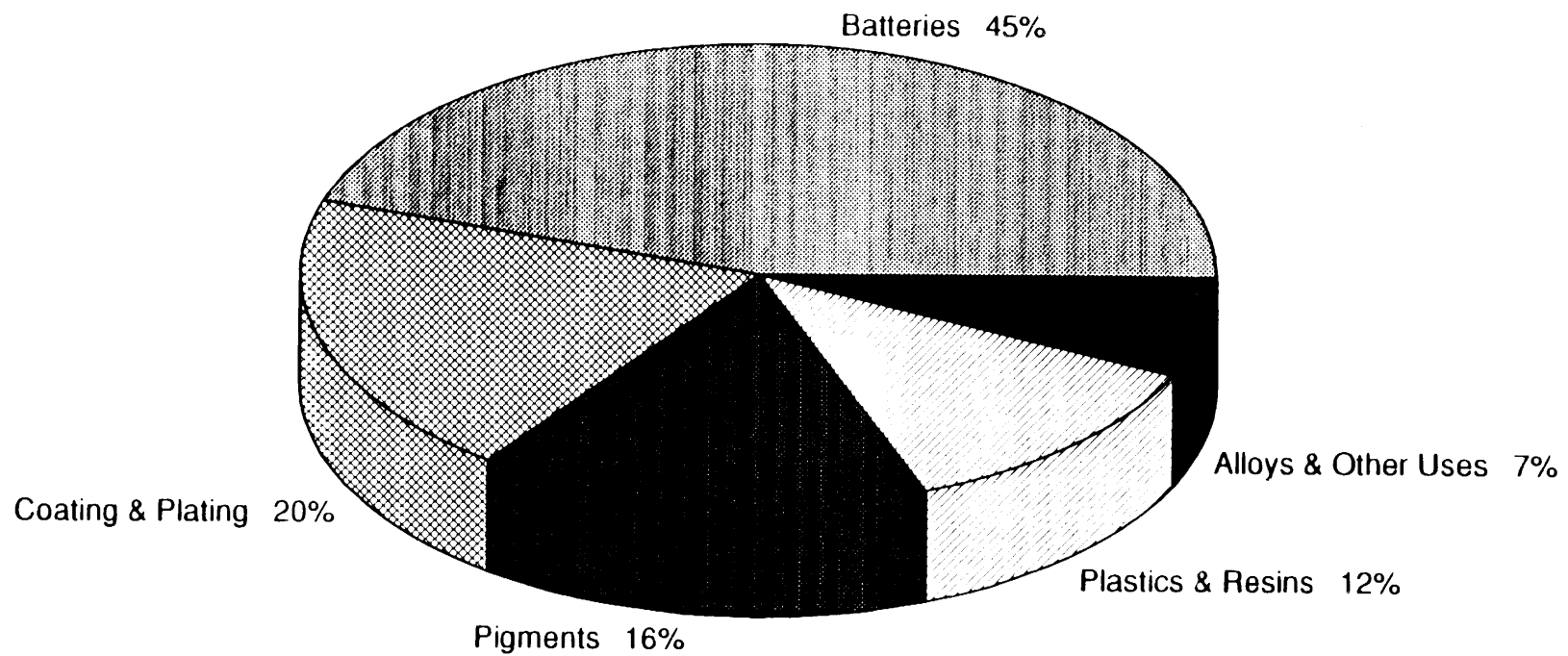

## Cadmium

Figure 3-2. End use pattern of cadmium.

method involved developing source-specific emission factors and applying those emission factors to estimates of nationwide source activity to calculate nationwide mercury emission estimates. The second method relied on extrapolating emission estimates from the Toxic Chemicals Release Inventory System (TRI).<sup>6</sup>

Cadmium is emitted from a number of industrial processes (e.g., fossil fuel combustion, waste incineration, and mineral processing operations) because it is present as a contaminant in the process feed. For those processes, an emission factor-based approach was used to estimate nationwide cadmium emissions. A comprehensive review and analysis of both information on cadmium content in the feed material and emission test data was conducted. Primary sources of information, which were used included ongoing EPA regulatory development activities, information that is being collected by EPA to develop toxic air pollutant emission factors in AP-42<sup>7</sup>, and an EPA data base on toxic air pollutant emission factors.<sup>8</sup> Upon completion of the review, a "best typical" emission factor was selected. This information was combined with readily available published data on source category activity to calculate nationwide emission estimates.

The source of emissions information used for source categories that involve cadmium use was the TRI form, required by Section 313 of Title III of the 1986 Superfund Amendments and Reauthorization Act (SARA 313).<sup>6</sup> This section requires owners and operators of facilities in Standard Industrial Classification (SIC) codes 20-39 that manufacture, import, process, or otherwise use toxic chemicals to report annual air releases of these chemicals. The emissions may be based on source tests (if available); otherwise, emissions may be based on emission factors, mass balances, or other approaches.

In selected cases, facilities reported to TRI under multiple SIC codes. As a result, it was difficult to assign emissions to a specific SIC code. In those cases, efforts were made to determine the appropriate SIC codes associated with the emissions. If appropriate SIC codes could not be explicitly identified, the data were not used in the analysis.

Table 3-2 presents a compilation of SIC codes that have been associated with cadmium emissions.<sup>7,8</sup> This table lists the SIC codes that were identified as a potential source of cadmium emissions, provides a description of the SIC code, and identifies other emission sources that do not have an assigned SIC code.<sup>7,8</sup>

Table 3-3 provides a summary of the estimated 1990 nationwide cadmium emissions for those source categories where adequate information was available (i.e., emission factors and production data). Appendix A presents the data used for each of these estimates, assumptions, and emission calculations for each of these source categories. The estimated emissions were based on emission factors provided in this document or calculated from source test data and appropriate process information, if available.

Of the five major source categories, cadmium emissions resulting from combustion sources accounted for a total of 266 Mg (293 tons) or approximately 82 percent of the total estimated emissions. Within the combustion source category, the major contributor to cadmium emissions was from the combustion of coal, followed by oil combustion, sewage sludge, and municipal waste. The nonferrous smelting and refining source category accounts for about 38 Mg (42 tons) or approximately 12 percent of the total estimated emissions.

TABLE 3-2. SIC CODES OF INDUSTRIES ASSOCIATED WITH CADMIUM EMISSIONS

| SIC code | Industry  |
|----------|---|
| 0711     | Soil Preparation Services (fertilizer application)                        |
| 266      | Woven Fabric Finishing  |
| 2611     | Pulp Mills  |
| 2621     | Paper Mills   |
| 2816     | Inorganic Pigments Manufacture  |
| 2819     | Industrial Inorganic Compounds, Not Elsewhere Classified (nec)            |
| 2851     | Paint and Allied Products   |
| 2869     | Industrial Organic Chemicals, nec (plastics stabilizers)                  |
| 2874     | Phosphate Fertilizers   |
| 2879     | Pesticides and Agricultural Chemicals, nec (trace elements)               |
| 2895     | Carbon Black  |
| 2911     | Petroleum Refining  |
| 2951     | Asphalt Paving Mixtures and Blocks  |
| 3053     | Gaskets, Packing, and Sealing Devices                                     |
| 3081     | Unsupported Plastic, Film and Sheet                                       |
| 3083     | Laminated Plastics, Plate, Sheet, and Profile Shapes                      |
| 3087     | Custom Compounding of Purchased Plastics Resins (with Cd pigments)        |
| 3089     | Plastics Products, nec  |
| 3229     | Pressed and Blown Glass and Glassware, nec                                |
| 3241     | Cement, Hydraulic (dry and wet process)                                   |
| 3264     | Porcelain Electrical Supplies   |
| 3312     | Blast Furnaces and Steel Mills  |
| 3313     | Ferroalloy Production   |
| 332      | Iron and Steel Foundries  |
| 3321     | Gray and Ductile Iron Foundries   |
| 3331     | Primary Copper Smelting and Refining                                      |
| 3339     | Primary Smelting and Refining of Nonferrous Metals (zinc, lead, cadmium)  |
| 3341     | Secondary Smelting and Refining of Nonferrous Metals (zinc, lead, copper) |
| 3351     | Copper Rolling, Drawing, and Extruding                                    |
| 3356     | Nonferrous Rolling and Drawing, Except Copper and Aluminum                |
| 3357     | Nonferrous Wire Drawing and Insulating                                    |
| 3362     | Brass, Bronze, Copper, Copper-Base Alloy Foundries                        |
| 3369     | Nonferrous Foundries, nec   |
| 3365     | Aluminum Foundries  |
| 3399     | Primary Metal Products, nec   |
| 3431     | Enameled Iron and Metal Sanitary Ware                                     |
| 3340     | Fabricated Structural Metal Products (diecasting)                         |
| 3452     | Bolts, Nuts, Screws, Rivets, and Washers                                  |
| 3471     | Plating and Polishing (cadmium electroplating)                            |
| 3492     | Fluid Power Valves and Hose Fittings                                      |
| 3494     | Valves and Pipe Fittings, nec   |

TABLE 3-2. (continued)

| SIC code | Industry  |
|----------|---|
| 3585     | Refrigeration and Heating Equipment             |
| 3691     | Storage Batteries                               |
| 3692     | Primary Batteries, Dry and Wet                  |
| 3694     | Internal Combustion Engine Electrical Equipment |
| 3714     | Motor Vehicle Parts and Accessories             |
| 3721     | Aircraft  |
| 3728     | Aircraft Parts and Auxiliary Equipment, nec     |
| 3952     | Lead Pencils, Crayons, and Artists' Materials   |
| 4953     | Refuse Systems (municipal waste combustion)     |
| 9661     | Space Research and Technology                   |
| --       | Coal Combustion                                 |
| --       | General Laboratory Use                          |
| --       | Oil Combustion                                  |
| --       | Wood Combustion                                 |
| --       | Natural Gas Combustion                          |

Source: References 7 and 8.



TABLE 3-3. ESTIMATED 1990 NATIONWIDE CADMIUM EMISSIONS  
FOR SELECTED SOURCE CATEGORIES

| Source Category                         | Cadmium Emissions |       | Basis               |
|---|-------------------|-------|---------------------|
|   | Mg                | Tons  |                     |
| <u>Cadmium Production</u>               |                   |       |                     |
| Cadmium Refining                        | 4.2               | 4.6   | Appendix A          |
| Cadmium Pigment Production              | 1.6               | 1.8   | Appendix A          |
| Cadmium Stabilizer Production           | NA                | NA    | No emission factors |
| Other Cadmium Compound Production       | NA                | NA    | No emission factors |
| <u>Major Uses of Cadmium</u>            |                   |       |                     |
| Cadmium Electroplating                  | NA                | NA    | No emission factors |
| Secondary Battery Manufacture           | 0.32              | 0.35  | Appendix A          |
| Cadmium Stabilizers (Plastics)          | NA                | NA    | No emission factors |
| Cadmium Pigments (Plastics)             | NA                | NA    | No emission factors |
| <u>Combustion Sources</u>               |                   |       |                     |
| Coal Combustion                         | 220.2             | 242.7 | Appendix A          |
| Oil Combustion                          | 23.5              | 25.9  | Appendix A          |
| Natural Gas Combustion                  | NA                | NA    | No emission factors |
| Municipal Waste Combustion              | 8.4               | 9.2   | Appendix A          |
| Sewage Sludge Combustion                | 9.9               | 10.9  | Appendix A          |
| Medical Waste Combustion                | 3.6               | 3.9   | Appendix A          |
| Wood Combustion                         | 0.38              | 0.41  | Appendix A          |
| <u>Nonferrous Smelting and Refining</u> |                   |       |                     |
| Primary Lead Smelting                   | 14.3              | 15.8  | Appendix A          |
| Primary Copper Smelting                 | 5.6               | 6.2   | Appendix A          |
| Primary Zinc Smelting                   | 5.7               | 6.3   | Appendix A          |
| Secondary Copper Smelting               | 10.8              | 11.9  | Appendix A          |
| Secondary Zinc Smelting (scrap)         | 1.5               | 1.7   | Appendix A          |
| Secondary Zinc Smelting (EAF)           | NA                | NA    | No emission factors |
| <u>Miscellaneous Sources</u>            |                   |       |                     |
| Iron and Steel                          | NA                | NA    | No emission factors |
| Portland Cement Production              | 13.1              | 14.4  | Appendix A          |
| Phosphate Rock Processing               | NA                | NA    | No emission factors |
| Carbon Black Production                 | 0.07              | 0.08  | Appendix A          |
| Mobile Sources                          | NA                | NA    | No emission factors |
| TOTAL                                   | 323               | 356   |                     |

NA = not available

## REFERENCES

1. Hollander, M. L., and S. C. Carapella, Jr. Cadmium and Cadmium Alloys. (In) Kirk-Othmer Encyclopedia of Chemical Technology. Volume 4. M. Grayson, ed. A Wiley-Interscience Publication, John Wiley and Sons, New York, NY. 1978.
2. Parker, P.D. Cadmium Compounds. (In) Kirk-Othmer Encyclopedia of Chemical Technology. Volume 4. 3rd ed. M. Grayson, ed. A Wiley-Interscience Publication, John Wiley and Sons, New York, NY. 1978.
3. Cadmium Association/Cadmium Council. Technical Notes on Cadmium. Cadmium in Alloys. Cadmium Association, London; Cadmium Council, New York, NY. 1978.
4. Cadmium Association. Cadmium. The Quality Metal. Cadmium Association, London. undated.
5. Llewellyn, T.O. Cadmium in 1991. Branch of Industrial Minerals, Division of Mineral Commodities, Bureau of Mines, U.S. Department of the Interior, Washington, DC. January 1993.
6. U. S. Environmental Protection Agency. 1990 Toxic Release Inventory, Office of Toxic Substances. Washington, DC. January 1993.
7. U. S. Environmental Protection Agency. Compilation of Air Pollution Emission Factors, AP-42, Fourth Edition, Supplement E. U. S. Environmental Protection Agency, Research Triangle Park, NC. October 1992.
8. XATEF. Crosswalk/Air Toxic Emission Factor Data Base. Version 2 for 1992 update. Office of Air Quality Planning and Standards, U. S. Environmental Protection Agency, Research Triangle Park, NC. September 1992.

## SECTION 4

### EMISSIONS FROM CADMIUM PRODUCTION

This section describes the potential sources of cadmium emissions from the production of cadmium and cadmium compounds. The following subsections, covering cadmium refining and cadmium oxide production, cadmium pigments production, cadmium stabilizer production, and other cadmium compounds, present process descriptions, identify potential cadmium emission sources and controls, and quantify cadmium emissions.

#### CADMIUM REFINING AND CADMIUM OXIDE PRODUCTION

Cadmium minerals do not occur in concentrations and quantities sufficient enough to justify mining them in their own right, but they are present in most zinc ores as cadmium sulfide (the mineral greenockite) and are concentrated during zinc ore processing.<sup>1</sup> The resulting zinc ore concentrates from ore processing contain from 0.1 to 0.8 percent cadmium by weight.<sup>1</sup> Cadmium metal is recovered as either: (1) a byproduct of the extraction and refining of zinc metal from zinc sulfide ore concentrates in electrolytic zinc smelters; or (2) the main product in the processing of lead blast furnace dusts. Cadmium oxide is produced in a secondary process using cadmium metal as the feed material.

Table 4-1 lists the cadmium metal and cadmium oxide producers along with their locations, process feed materials, and processes

TABLE 4-1. CADMIUM AND CADMIUM OXIDE PRODUCERS

| Cadmium Refining Plant      | Location         | Feed Material   | Process                           |
|-----------------------------|------------------|---|-----------------------------------|
| <u>Cadmium Metal</u>        |                  |   |                                   |
| ASARCO, Inc.                | Denver, CO       | Crude CdO in blast furnace baghouse dust from East Helena lead smelter. | Electromotive Cd                  |
| Big River Zinc Corp.        | Sauget, IL       | Zinc roaster calcine.   | Electromotive Cd                  |
| Jersey Miniere Zinc (JMZ)   | Clarksville, TN  | Zinc roaster calcine.   | Electrolytic Cd                   |
| Zinc Corp. of America (ZCA) | Bartlesville, OK | Zinc roaster calcine. <sup>a</sup>                                      | Electromotive Cd                  |
| <u>Cadmium Oxide</u>        |                  |   |                                   |
| ASARCO, Inc.                | Denver, CO       | Cd metal.   | Air oxidation from retort furnace |
| Big River Zinc Corp.        | Sauget, IL       | Cd metal.   | Air oxidation from retort furnace |
| Proctor and Gamble Co.      | Phillipsburg, NJ | Not available.  | Not available                     |
| Witco Chemical Co.          | Brooklyn, NY     | Cd metal.   | Air oxidation from retort furnace |

<sup>a</sup>ZCA also has an electrothermic primary zinc smelter in Monaca, Pennsylvania. That smelter also uses a crude zinc calcine recovered from steelmaking electric arc furnace (EAF) dusts. The calcine from the EAF dusts also contains cadmium.

Source: References 1-3

used. Currently, there are four plants that produce cadmium metal in the United States; two of these four plants also produce cadmium oxide. Three of the four cadmium metal refining plants are colocated at electrolytic zinc smelters and include: Big River Zinc (BRZ) Corporation located in Sauget, Illinois; Jersey Miniere Zinc (JMZ) located in Clarksville, Tennessee; and Zinc Corporation of America (ZCA) located in Bartlesville, Oklahoma. The fourth cadmium metal refining plant, ASARCO, Inc., is located in Denver, Colorado and processes lead blast furnace dust. Cadmium oxide is produced at both BRZ and ASARCO. (Another ZCA primary zinc smelter, in Monaca, Pennsylvania, does not have an associated cadmium refinery).<sup>2</sup>

Reference 3 lists Proctor and Gamble Co. as a producer of cadmium oxide. However, at the present time, it is not clear whether cadmium oxide is manufactured at this location or whether the company only distributes cadmium oxide from this location. Cadmium oxide is also produced at Witco Chemical Company located in Brooklyn, New York. This plant produces cadmium oxide for its own use in the production of cadmium stabilizers.

#### Process Description<sup>1</sup>

Figure 4-1 is a general process flow diagram for the production of cadmium metal and cadmium oxide at electrolytic and electromotive cadmium refining plants. At the three electrolytic zinc smelters, cadmium is removed as an impurity from the leachate solution of the roasted zinc ore concentrate or calcine. Cadmium is also recovered from solutions obtained by leaching lead blast furnace baghouse dusts containing impure cadmium oxide with a weak sulfuric acid solution. In 1986, the source of the dusts treated by the ASARCO cadmium refinery was ASARCO's East Helena lead smelter. Currently, ASARCO uses Godfrey roaster baghouse dust from the ASARCO El Paso lead smelter.<sup>4</sup>

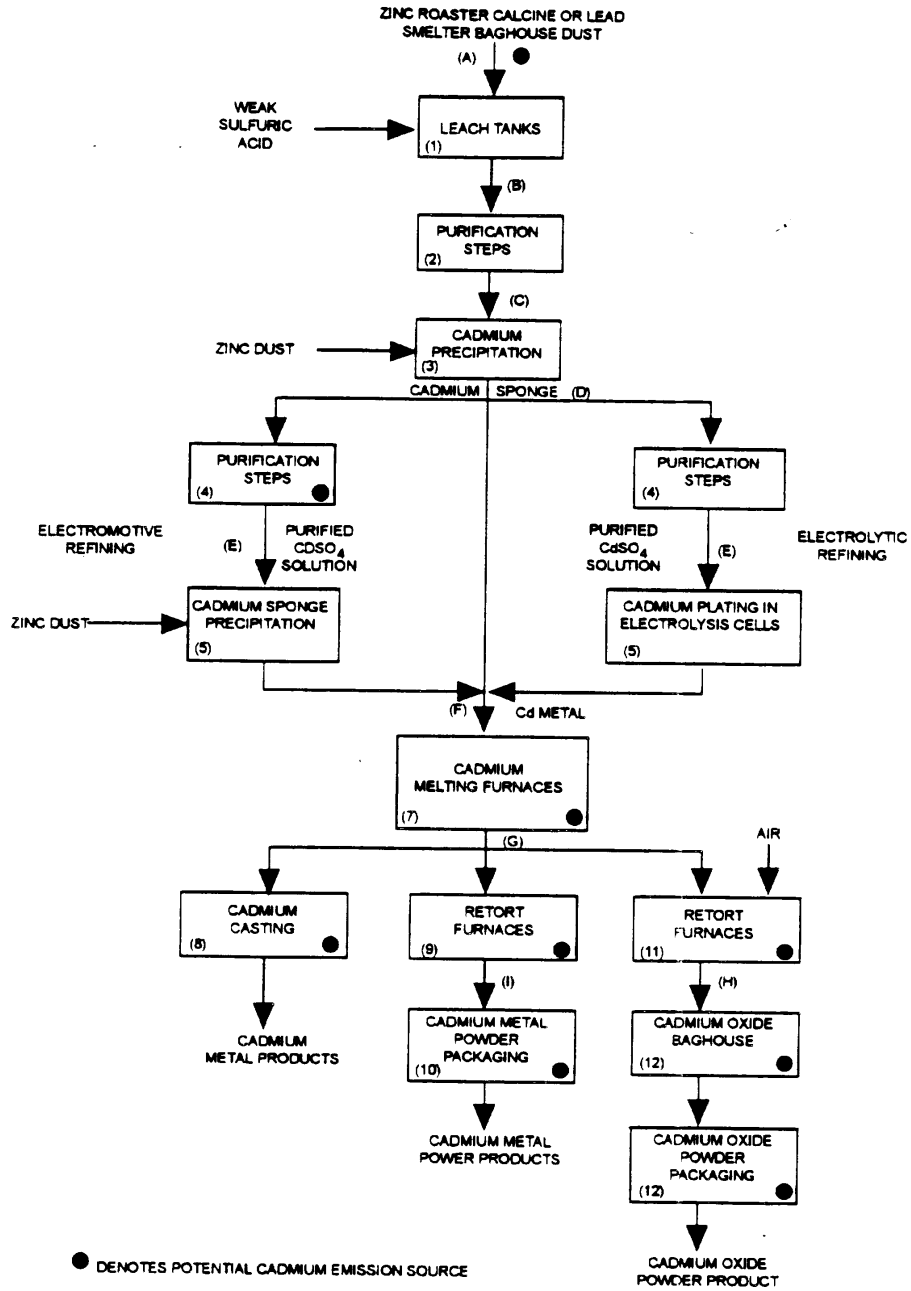

Figure 4-1. Flow diagram for cadmium refining.<sup>10</sup>

The cadmium-bearing feed (Stream A) is leached or dissolved in sulfuric acid in Step 1. Next, the sulfuric acid solution (Stream B) is treated by various solution purification steps (Step 2). The purified solution (Stream C) is treated with zinc dust to precipitate a metallic cadmium "sponge" (Stream D) (Step 3). The cadmium sponge is redissolved in sulfuric acid; the solution undergoes additional purification steps to produce a purified solution (Stream E or E'; Step 4). The JMZ cadmium refinery in Clarksville, Tennessee uses the electrolytic process to recover metallic cadmium from the purified cadmium sulfate solution (Stream E). The other cadmium refineries use the electromotive process.<sup>3</sup>

In the electrolytic cadmium refining process (Step 5), electrolysis of the purified cadmium sulfate solution (Stream E) deposits cadmium on cathodes. The cadmium metal (Stream F) is stripped from the electrodes and transferred to a cadmium melting furnace (Step 7). The molten cadmium (Stream G) is cast into balls and sheets for cadmium electroplating anodes or cast into slabs, ingots, and sticks for alloying, pigment production, and cadmium oxide production (Step 8).

In the electromotive cadmium refining process, zinc dust is added to the purified cadmium sulfate solution (Stream E') to displace cadmium as "sponge" metal (Stream F) in Step 6. The sponge is briquetted, melted (Step 7), and cast (Step 8) into products for sale or further processing.

JMZ and ZCA produce only cast cadmium metal products. ASARCO and BRZ also produce powdered cadmium metal, cadmium oxide, or both. Cadmium from the melting furnace (Stream G) is transferred to a retort furnace (Step 9 or 11). In powdered cadmium production (Step 9), cadmium (Stream G) is routed to a sealed

retort that has been purged of oxygen with carbon dioxide. Cadmium vaporizes and condenses as a powder (Stream I) during retorting in the absence of oxygen. The condensed powder is packaged in Step 10. In cadmium oxide production (Step 11), retorting in air oxidizes cadmium to cadmium oxide, which is collected in a baghouse (Step 12) and packaged (Step 13).

### Emissions and Controls

During cadmium and cadmium oxide production, cadmium is emitted from melting furnaces (Step 7), retorting (Steps 9 and 11), casting and tapping (Step 8), and packaging (Steps 10 and 13). Charging the leach tanks for Step 1 with lead blast furnace dusts (Stream A) and solutions heating tanks (Step 4) at the Denver refinery were additional sources.

In 1986, the EPA inventoried cadmium emission sources at cadmium refining plants based on Section 114 responses, emission test reports, trip reports, and a previous cadmium source survey published in 1985.<sup>5</sup> Initially generated emissions estimates were revised based on industry comments. Table 4-2 shows the cadmium emission rates developed in 1986 for normal and maximum operation at three of the four cadmium refining plants. Revised estimates for normal operations using the same general emission estimation methodology at the BRZ plant were made in 1989<sup>6</sup> and are presented in the table in place of the 1986 data. However, the data shown for maximum operation are from the 1986 study. Revised emission estimates for the ASARCO plant were developed in 1992 for the State of Colorado by JACA Corporation.<sup>4</sup> The ASARCO facility had undergone substantial modifications since the 1986 study. The JACA study developed emission estimates for maximum operation only. These data are reported in Table 4-2. Emission estimates for normal operation from the 1986 study are not reported in Table 4-2 because of the process and control modifications



TABLE 4-2. INVENTORY OF CADMIUM EMISSION SOURCES AND CONTROLS FOR CADMIUM REFINING PLANTS

| Plant                                   | Source   | Type <sup>a</sup> | Emissions, kg/yr  |                  | Control device <sup>b</sup> |
|---|--|-------------------|-------------------|------------------|-----------------------------|
|   |  |                   | Maximum operation | Normal operation |                             |
| Big River Zinc Company, Sauget, IL      | (7) Cadmium melting furnace                              | H                 | 70                | 0                | UNC, L                      |
|   | *Cadmium holding furnace                                 | H                 | 93                | 76               | UNC                         |
|   | (8) Cadmium casting furnace + tapping/casting            | F                 | 68                | <1               | BH                          |
|   | (11) Cadmium oxide furnace                               | H                 | 814               | 661              | BH                          |
|   | Total Sauget   |                   | 1,045             | 737              |                             |
| Jersey Miniere Zinc, Clarksville, TN    | (7-8) Cadmium melting/casting furnace                    | H                 | <1                | <1               | BH, L                       |
| Zinc Corp. of America, Bartlesville, OK | (7-8) Cadmium melting/casting furnace                    | H                 | <1                | <1               | WS                          |
|   | (8) Cadmium tapping/casting                              | H                 | <1                | <1               | UNC                         |
| ASARCO Globe, Denver, CO                | (1) Hot water leaching                                   |                   |                   |                  |                             |
|   | Dust charging  | H                 | 8.8               | ---              | UNC                         |
|   | Reaction/Filtration                                      | H                 | 6.1               | ---              | UNC                         |
|   | (1) Acid leaching  | H                 | 4.3               | ---              | UNC                         |
|   | (4) Purification   | H                 | 6.1               | ---              | UNC                         |
|   | (4) Solutions heating                                    |                   |                   |                  |                             |
|   | Charging and pump out                                    | H                 | 1.7               | ---              | UNC                         |
|   | Heating  | H                 | 158.5             | ---              | UNC                         |
|   | (4) Sponge Production                                    | H                 | 2.1               | ---              | UNC                         |
|   | *Premelt   | H                 | 12.7              | ---              | BH                          |
|   | Retort Building  |                   |                   |                  |                             |
|   | (12) CdO production                                      | H                 | 56.6              | ---              | BH                          |
|   | (10) CdO packaging                                       | H                 | 11.6              | ---              | BH                          |
|   | (10) CdO packaging                                       | H                 | 23.2              | ---              | BH                          |
|   | (10) Cd packaging  | H                 | 11.2              | ---              | BH                          |
|   | *Furnaces, hoods, Cd melting, Cd condenser               | H                 | 70.8              | ---              | BH                          |
|   | *Fugitive emissions (roadways, by-product storage piles) | F                 | <3                | ---              | DS                          |
| Total Denver                            |  |                   | 377               |                  |                             |

<sup>a</sup>H = point source; F = fugitive source.

<sup>b</sup>UNC = uncontrolled; BH = baghouse; WS = wet scrubber; DS = dust suppressant; L = layer of caustic on molten cadmium.

<sup>c</sup>Based on AP-42 methodology developed for aggregate materials.

\*Source not depicted in Figure 4-1.  
Source: References 1,4, and 6V

implemented at ASARCO since then, because of the use of new emission test data from tests conducted since 1986, and because the emission estimation methodologies used in 1986 versus the 1992 JACA study are substantially different. The emission sources are numbered using the same numbering scheme as in Figure 4-1.

Cadmium melting furnaces and cadmium retort furnaces were identified as the two types of process emission sources at cadmium refining plants. Cadmium melting furnaces are used to melt either cadmium sponge or sheets.<sup>1</sup> A layer of caustic on the molten metal surface is used to prevent oxidation of the metal, to help remove impurities, and to provide some control of particulate matter at three cadmium refining plants.<sup>1</sup> The other plant (JMZ) uses a layer of resin to achieve the same results.<sup>1</sup> Process cadmium emissions from the melting furnace are controlled by a baghouse at JMZ and by a wet scrubber at ZCA.<sup>1</sup> A hooding system ducts fugitive emissions from the charging/drossing port and from the tapping/casting area to the baghouse at JMZ.<sup>1</sup> At ASARCO, forced ventilation is in place during furnace operation and during charging and tapping/casting.<sup>1</sup> Since the 1986 study, BRZ made several improvements in their cadmium refining process. Among these improvements, was the ducting of the cadmium tapping/casting area of the cadmium melting furnace to the existing lead anode furnaces' process fugitive emissions baghouse.<sup>6</sup>

Cadmium retort furnaces are used only at BRZ and ASARCO in the production of cadmium oxide and/or cadmium metal.<sup>1</sup> Emissions from these sources were estimated using emission test data from these plants.<sup>1</sup> In October 1988, BRZ also made improvements to the cadmium oxide product collection system.<sup>6</sup> The changes included a new product collection baghouse, a new ventilation system and fugitive emissions baghouse, and an enclosed and automated cadmium oxide packaging operation. While these changes

enhanced the operation of the cadmium oxide system, it was assumed that no reductions in emissions were realized. The new baghouse has the same operating parameters as the one that was replaced. Therefore, the test conducted in 1986 was still considered to be valid and was used to develop emission estimates. Additionally, fugitive emissions from cadmium oxide production and packaging had been assumed to be negligible in 1986 because at that time, the cadmium oxide production and packaging operations were housed in a separate room within the cadmium building; the new ventilation system probably improves working conditions inside the cadmium oxide production and packaging areas. ASARCO has also improved operations at the Denver location with the addition of a baghouse to control emissions from premelt operations and another baghouse to control fugitive emissions from the Cd furnaces, hoods, Cd melting operations, and the Cd condenser in the retort department.<sup>4</sup>

Because three of the four cadmium refineries are operated in conjunction with zinc smelters, the annual emissions reported by these plants in the 1990 Toxic Chemicals Release Inventory (see Table 4-3) comprise the sum of both sources.<sup>7</sup> The 860 kg (1,896 lb) cadmium emission reported by Big River Zinc Corporation is slightly more than the sum of the estimates in Reference 4 for the cadmium refining operations (737 kg) and primary zinc smelting (100 kg). The JMZ plant reported 227 kg (500 lb) cadmium emissions in 1990 compared to the 1986 estimates of <1 kg for the cadmium refinery and 28 kg for the zinc smelter. The ZCA plant reported a total of 2,936 kg (6,472 lb) cadmium emitted in 1990, whereas the 1986 estimates were <1 kg for the refinery and 12 kg for the smelter. The ASARCO cadmium refining plant reported 180 kg (396 lb) cadmium emissions (177 kg [391 lb] from point sources) in 1990.<sup>7</sup> The differences between these estimates (1990 TRI and references 1, 4, and 6) are likely the result of differences in production and in the assumptions used

TABLE 4-3. PRIMARY ZINC AND CADMIUM PRODUCERS REPORTING CADMIUM EMISSIONS IN THE 1990 TOXIC CHEMICALS RELEASE INVENTORY

| Plant   | Emissions, kg (lb) |                  |                  | Monitoring Data |
|---|--------------------|------------------|------------------|-----------------|
|   | Nonpoint           | Point            | Total            |                 |
| Asarco Inc, Globe Plant,<br>Denver, Colorado<br>(Cadmium refinery from lead smelter<br>dusts) | 2<br>(5)           | 177<br>(391)     | 180<br>(396)     | no              |
| Big River Zinc Corp.,<br>Sauget, Illinois   | 113<br>(250)       | 747<br>(1,646)   | 860<br>(1,896)   | no              |
| Jersey Miniere Zinc,<br>Clarksville, Tennessee  | 113<br>(250)       | 113<br>(250)     | 226<br>(500)     | yes<br>(point)  |
| Zinc Corporation of America,<br>Bartlesville, Oklahoma  | 2<br>(4)           | 2,934<br>(6,468) | 2,936<br>(6,472) | no              |
| TOTAL   | 230<br>(509)       | 3,971<br>(8,755) | 4,202<br>(9,264) |                 |

<sup>a</sup>Currently not a cadmium refiner.

Source: Reference 7.

to develop the emission estimates. For example, at BRZ, the plant personnel still use the emission factors developed from the 1986 study to develop their emission estimates and multiply these factors by the production levels for the particular year. Also, because the levels of cadmium in the zinc sulfide ore residues vary by almost an order of magnitude, the resulting emission estimates could also vary significantly.

Table 4-4 provides emission factors for the cadmium refining plant using lead blast furnace dusts. These emission factors were developed from the 1992 JACA study by using the maximum annual emissions from Table 4-2 and dividing by the maximum production rate data as noted in the footnotes in Table 4-4.

Emission factors for the cadmium metal and cadmium oxide production processes are presented in Table 4-5. These emission factors were developed based on emission tests conducted at two of the cadmium refining plants.

#### CADMIUM PIGMENTS PRODUCTION

Cadmium is emitted during the manufacture of cadmium pigments. This subsection will describe the manufacturing process, emissions, and controls. Most of the information herein is from a 1988 Emission Standards Division report on cadmium emissions from pigment and stabilizer manufacture and the 1985 Background Information Document for Cadmium Emission Sources.<sup>5,8</sup>

Cadmium pigments are stable inorganic coloring agents that provide a range of brilliant shades of yellow, orange, red, and maroon. The pigments are based on cadmium sulfide (CdS), which yields a golden yellow pigment. Partial substitution of cadmium in the crystal lattice by zinc or mercury, and of sulfur by selenium, produces a series of intercrystalline compounds making

TABLE 4-4. CADMIUM EMISSION FACTORS FOR CADMIUM REFINING PLANT USING LEAD BLAST FURNACE DUST

| Process step (emission type <sup>a</sup> )                   | Emission factor     |                     | Control <sup>b</sup> |
|--|---------------------|---------------------|----------------------|
|  | lb/ton Cd produced  | kg/Mg Cd produced   |                      |
| (1) Hot water leaching                                       |                     |                     |                      |
| Dust charging (H)  | 0.0297 <sup>c</sup> | 0.0149 <sup>c</sup> | UNC                  |
| Reaction/filtration (H)                                      | 0.0207 <sup>c</sup> | 0.0103 <sup>c</sup> | UNC                  |
| (1) Acid leaching (H)  | 0.0146 <sup>c</sup> | 0.0073 <sup>c</sup> | UNC                  |
| (4) Purification (H)   | 0.0207 <sup>c</sup> | 0.0103 <sup>c</sup> | UNC                  |
| (4) Solution Heating   |                     |                     |                      |
| Charging & pump out (H)                                      | 0.0029 <sup>c</sup> | 0.0057 <sup>c</sup> | UNC                  |
| Heating (H)  | 0.535 <sup>c</sup>  | 0.268 <sup>c</sup>  | UNC                  |
| (4) Sponge Production (H)                                    | 0.007 <sup>c</sup>  | 0.0035 <sup>c</sup> | UNC                  |
| *Premelt (H)   | 0.0429 <sup>c</sup> | 0.0214 <sup>c</sup> | BH                   |
| Retort Building  |                     |                     |                      |
| (12) CdO production(H)                                       | 0.1333 <sup>d</sup> | 0.0667 <sup>d</sup> | BH                   |
| (10) CdO packaging (H)                                       | 0.0274 <sup>d</sup> | 0.0137 <sup>d</sup> | BH                   |
| (10) CdO packaging (H)                                       | 0.0546 <sup>d</sup> | 0.0273 <sup>d</sup> | BH                   |
| (10) Cd packaging (H)  | 0.071 <sup>e</sup>  | 0.0355 <sup>e</sup> | BH                   |
| *Furnaces, hoods, Cd melting, cd condenser (H)               | 0.1216 <sup>f</sup> | 0.0608 <sup>f</sup> | BH                   |
| *Fugitive emissions (roadways, by-product storage piles) (F) | 0.0051 <sup>f</sup> | 0.0026 <sup>f</sup> | DS                   |

<sup>a</sup>H=point source, F=fugitive source

<sup>b</sup> UNC=uncontrolled, BH=baghouse, WS=wet scrubber, DS=dust suppressant

<sup>c</sup>Emission factors calculated by dividing the annual emissions from Table 4-2 by the maximum annual throughput through the leaching, solutions, and premelt department of 592.2 Mg Cd/yr (652.8 tons Cd/yr).

<sup>d</sup>Emission factors calculated by dividing the annual emissions from Table 4-2 by the maximum annual throughput of CdO of 849.1 Mg Cd/yr (936 tons Cd/yr).

<sup>e</sup>Emission factors calculated by dividing the annual emissions from Table 4-2 by the maximum annual throughput of Cd powder of 315.7 Mg Cd/yr (348 tons Cd/yr).

<sup>f</sup>Emission factors calculated by dividing the annual emissions from Table 4-2 by the maximum plant throughput of 1,164.8 Mg Cd/yr (1,284 tons Cd/yr).

\*Step not depicted in Figure 4-1.

Source: Developed from information from Reference 4.

TABLE 4-5. EMISSION FACTORS FOR CADMIUM AND CADMIUM OXIDE PRODUCTION

| Process <sup>a</sup>   | Emission Factor        |                        | Control/ Basis   |
|--|------------------------|------------------------|--|
|  | lb/ton Cd <sup>b</sup> | kg/Mg Cd <sup>b</sup>  |  |
| (7) Cadmium melting furnace  | 0.149 <sup>c</sup>     | 0.075 <sup>c</sup>     | Uncontrolled. Emission factor based on source test   |
| (8) Cadmium tapping/ casting   | 0.00149                | 0.00075                | Partly enclosed hood ducted to baghouse or wet scrubber. Emission factor   |
| *Cadmium holding furnace   | 0.149                  | 0.075                  | Uncontrolled, Emission factor  |
| (11) Cadmium oxide furnace fugitive emissions (includes packaging fugitives) | 1.9 x 10 <sup>-4</sup> | 9.8 x 10 <sup>-5</sup> | Baghouse. Based on workroom air sampling.  |
| (11) Cadmium oxide furnace   | 1.30                   | 0.651                  | Estimate based on product collection baghouse test. Method 5 sampling June 1986 (n=3). Estimated for 1988 prodn. |

<sup>a</sup>Numbers correspond to the steps in Figure 4-1. An asterisk denotes a step not shown in the figure.

<sup>b</sup>Based on the amount of cadmium processed. For example, for Big River Zinc Corp., 1,016 Mg (1,120 tons) cadmium was processed in 1988 to produce 1,110 Mg (1,220 tons) cadmium oxide. (About 5 percent of the CdO produced was rejected.) All cadmium metal produced was used to produce CdO.

<sup>c</sup>Did not use in estimating BRZ emissions from this source. Assumed negligible because of layer of caustic.

Source: Reference 6.

up the intermediate colors in the lemon-yellow to maroon range of colors. Table 4-6 lists the most common cadmium pigments produced in 1991. Table 4-7 lists the current cadmium pigment producers.

Cadmium pigments have excellent thermal stability which makes them essential for use in high-temperature processing, or where high service temperatures are encountered. Most cadmium pigments are used in plastics, but they are also used in paints, coatings, ceramics, glasses, and to a lesser degree in rubber, paper, and inks.<sup>9</sup>

There are two basic types of cadmium pigments produced in the United States: pure pigments, based on cadmium sulfide or cadmium selenide; and lithophone pigments, which are pure cadmium pigments that have been diluted with barium sulfate. The pure pigments are used undiluted when low pigment loadings are desired as in color concentrates for plastics. Lithopones have only one-half the tinting power of pure pigments, but when high pigment loadings can be tolerated, lithopones offer tinting strength and hiding power comparable, on an equal cost basis, with the pure pigments. Their greatest use is in the coloring of plastics with dry blends.<sup>8</sup>

#### Process Description<sup>5,8,9</sup>

Cadmium pigment production is based on a generic process, illustrated in Figure 4-2. However, cadmium pigment manufacturers have developed differing proprietary procedures for creating pigments, with specific hues and properties. These proprietary procedures include varying types and percentages of ingredients, altering the calcination time, and adding or deleting filtration, washing, drying, blending, or grinding operations.



TABLE 4-6. COMMON CADMIUM PIGMENTS PRODUCED IN 1991

| C.I. Pigment | Name                                       |
|--------------|--|
| Orange 20    | Cadmium sulfoselenide orange               |
| Orange 20:1  | Cadmium sulfoselenide lithophone<br>orange |
| Red 108      | Cadmium sulfoselenide red                  |
| Red 108:1    | Cadmium sulfoselenide lithophone red       |
| Yellow 35    | Cadmium zinc sulfide yellow                |
| Yellow 35:1  | Cadmium zinc sulfide lithophone<br>yellow  |
| Yellow 37    | Cadmium sulfide yellow                     |
| Yellow 37:1  | Cadmium sulfide lithophone yellow          |

Note: Each pigment is manufactured by all companies listed in Table 4-7, except Orange 20:1, which is not produced by the New Jersey plant.

TABLE 4-7. CURRENT CADMIUM PIGMENT PRODUCERS

| Company name   | Location             |
|--|----------------------|
| Engelhard Corporation,<br>Pigments and Additives Division<br>(Formerly Harshaw/Filtrol Partnership)                | Louisville, KY       |
| Ferro Corporation, Coatings, Colors,<br>and Electronic Materials Group, Color Division                             | Cleveland, OH        |
| Hanson Industries, SCM Chemicals, Inc.,<br>Subsidiary  | Baltimore, MD        |
| Universal Foods Corporation, Warner-Jenkinson Company,<br>H.K. Color Group,<br>(Formerly H. Kohnstamm and Company) | South Plainfield, NJ |

Source: Reference 3.

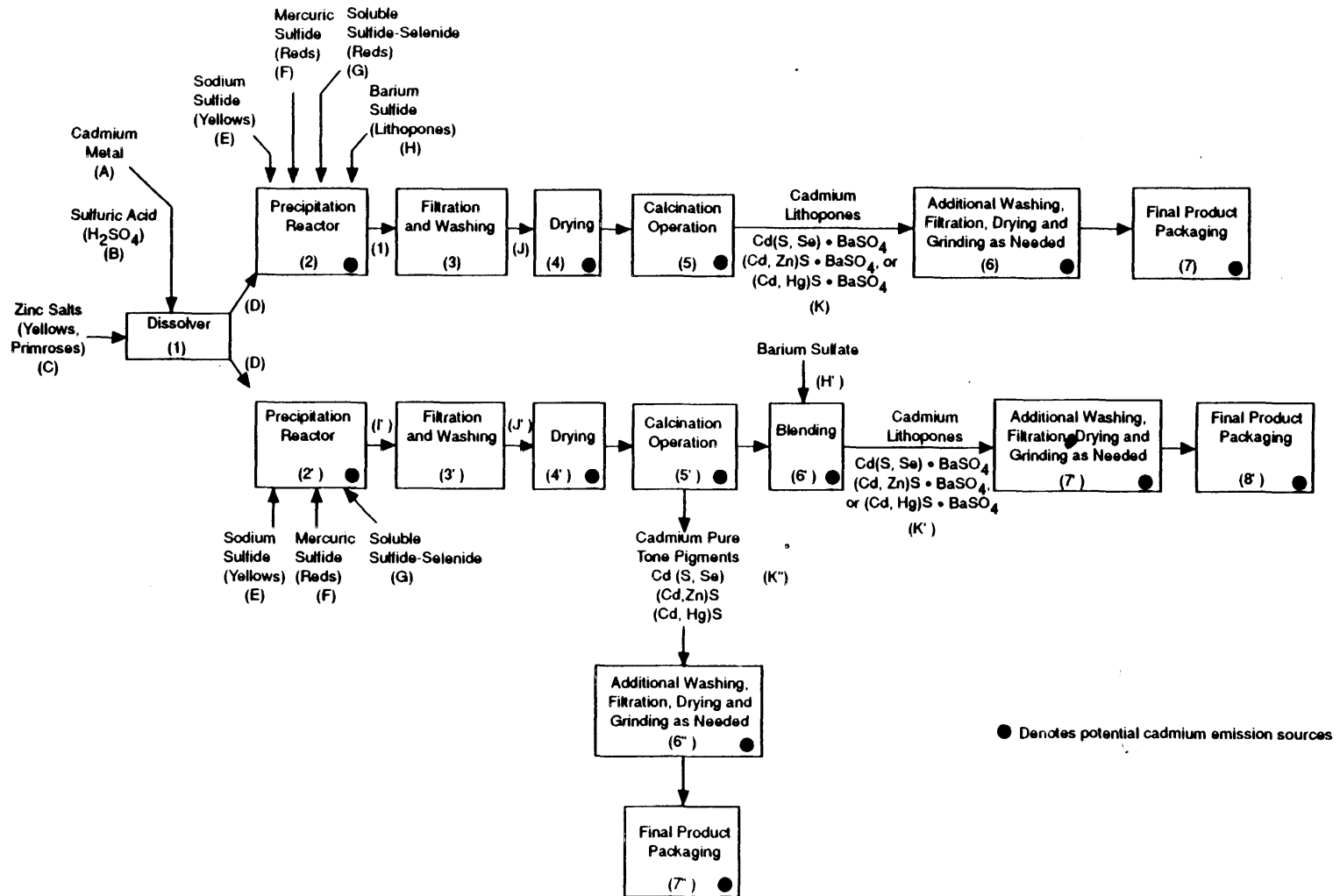

Figure 4-2. Process flowsheet for the production of cadmium pigments. 14, 16, 17

The source of cadmium for cadmium pigment production is a pure solution of either cadmium sulfate,  $\text{CdSO}_4$ , or cadmium nitrate,  $\text{Cd}(\text{NO}_3)_2$ . Cadmium sulfate is more commonly used. These solutions are either purchased in bulk or produced on-site by dissolving cadmium oxide, cadmium metal, or cadmium sponge (a porous, high-surface-area form of cadmium metal) (Stream A) in the appropriate acid (Stream B). Zinc salts (Stream C) may be added to the dissolver (Step 1). The  $\text{CdSO}_4$  solution (Stream D) is then routed to a precipitation reactor (Step 2 or 2') and mixed with varying quantities of an aqueous solution of sodium sulfide (or other alkali sulfide, depending on the desired color) (Stream E). This precipitates CdS in crystallographic form. To form pigments with a red shade (cadmium sulfoselenides), the cadmium sulfate solution (Stream E) is reacted with an alkali sulfide-selenide (Stream G). Reds can also be produced by adding mercuric sulfide (Stream F) to the precipitation reactor.

Cadmium pure tone pigment production (no  $\text{BaSO}_4$ ) is depicted in the figure by the path incorporating steps 1, 2'-5', 6'', and 7''. Lithopone production is represented in Figure 5 by two paths, Steps 1-7 and Steps 1, 2'-8'. To form lithopones, barium is either added to the precipitation Reactor 2 as barium sulfide (Stream H) or added to the mechanical blender (Step 6') as barium sulfate (stream H').  $\text{BaSO}_4$  precipitates along with CdS or Cd(S, Se) in Reactor 2.

When the batch process precipitation reaction is complete, the CdS or Cd(S,Se) precipitates (Stream I with  $\text{BaSO}_4$ ; Stream I' without  $\text{BaSO}_4$ ) are filtered from the solution, washed, and dried in Steps 3 or 3' and 4 or 4'. The very fine, colored particulates (Stream J or J') do not yet possess pigment properties. The colors and properties of the pigments develop during their calcination, or roasting. In the calcination

process (Step 5 or 5'), the dried pigment precipitate material (Stream J or J') is transferred to a furnace and heated to between 550° and 650°C (1022° to 1202°F). This converts the pigment material from a cubic to a more stable, hexagonal crystal structure. In an alternative route to lithopone pigments, the cadmium pure tone pigment produced by Step 5' may be blended in Step 6' with barium sulfate (Stream H'). The calcined pigment (Stream K, K', or K'') is then washed with hydrochloric acid to remove any remaining soluble cadmium particles. The product is then washed with water, filtered, and dried (Step 6 or 7' for lithopones; Step 6'' for pure tone pigments). The cadmium pigment emerges as a filter cake, which is either ground and packaged as the final product, or further processed before final packaging. The fine, discrete pigment particles have diameters of about 1 µm (range 0.1 to 3.5 µm).

#### Emissions and Controls

Cadmium is potentially emitted from the dissolver (Step 1), the precipitation reactor (Step 2, 2'), the dryer (Step 4, 4') the calcining furnace (Step 5 or 5'), the blender (Step 6'), and final product packaging (Step 7, 8', 7"). Calcining emissions are the largest source of cadmium in the form of CdS, Cd(S,Se), or Cd pigment (25 percent Cd in lithopone; 65 percent in pure Cd pigment). Standard particulate matter emission controls are used.

Reactor charging for CdSO<sub>4</sub> production (Step 1) (at two plants) is typically uncontrolled, though it is controlled by a low-energy wet scrubber at the Louisville, Kentucky, plant. Calcining operations are generally controlled by wet scrubbers. Drying operations are most often uncontrolled; the Louisville plant controlled dryer emissions with a low-energy wet scrubber. Tray design dryers have low cadmium emissions. Grinding,

blending, and packaging operations are generally controlled by baghouses. Fugitive emissions occurring inside buildings during the transfer and handling (loading, unloading) of cadmium-containing materials are typically captured by hoods and ducted to a control device. Packaging emissions are low.<sup>5,8</sup>

Table 4-8 lists cadmium emissions reported by the inorganic pigment plants in the 1990 Toxic Chemicals Release Inventory.<sup>7</sup> The estimates from the 1990 Inventory for three of the four current cadmium pigment producers (denoted by footnote "a" in Table 4-8) add up to 0.83 Mg (1,838 lb).<sup>7</sup>

The results of two studies of the cadmium pigment industry were published in references 4 and 6. Both of these studies estimated cadmium emissions and developed cadmium emission factors from individual sources at each of the four plants identified to be producing cadmium pigments. Each of the four plants provided information through Section 114 information requests. Additionally, site visits were made to three of these plants and emission tests were conducted at two of the plants. Throughout these studies, the individual plants claimed process descriptions and all process data to be confidential business information (CBI). As a result, emissions from each plant are presented in these references as total cadmium emissions instead of by individual emission source. Because the production data is CBI, emission factors cannot be determined for any sources in this source category.

#### CADMIUM STABILIZERS PRODUCTION

Cadmium is emitted during the manufacture of cadmium stabilizers. This subsection will describe the manufacturing process, emission sources, and emission controls.

TABLE 4-8. INORGANIC PIGMENTS MANUFACTURERS REPORTING CADMIUM EMISSIONS IN THE 1990 TOXIC CHEMICALS RELEASE INVENTORY

| Plant   | Emissions, kg (lb) |                  |                  | Monitoring Data   |
|---|--------------------|------------------|------------------|-------------------|
|   | Nonpoint           | Point            | Total            |                   |
| CP Chemicals Inc.<br>Sumter, South Carolina   | 113<br>(250)       | 113<br>(250)     | 226<br>(500)     | no                |
| Drakenfeld Colors,<br>Ciba-Geigy Pigments Division,<br>Washington, Pennsylvania   | 10<br>(23)         | 136<br>(300)     | 146<br>(323)     | yes<br>(nonpoint) |
| Ferro Corp.,<br>Cleveland, Ohio <sup>a</sup>  | 113<br>(250)       | 45<br>(98)       | 158<br>(348)     | no                |
| Ferro Corp.,<br>Pittsburgh, Pennsylvania  | 113<br>(250)       | 5<br>(10)        | 118<br>(260)     | no                |
| Engelhard Corp.<br>Louisville, Kentucky <sup>a</sup>  | 7<br>(15)          | 590<br>(1,300)   | 597<br>(1,315)   | no                |
| Johnson Matthey Inc.<br>West Chester, Pennsylvania (also reported<br>under several other possible SICs, including<br>3341, secondary nonferrous metals) | 113<br>(250)       | 113<br>(250)     | 226<br>(500)     | no                |
| SCM Glidco Organics Corp.<br>(Hanson Industries),<br>Baltimore, Maryland <sup>a</sup>   | 0                  | 79<br>(175)      | 79<br>(175)      | no                |
| TOTAL   | 470<br>(1,038)     | 1,081<br>(2,383) | 1,551<br>(3,421) |                   |

<sup>a</sup>Current cadmium pigment manufacturer in Table 4-7.

Source: Reference 7.

Cadmium-containing stabilizers are used to arrest the degradation processes that occur in polyvinyl chloride (PVC) and related polymers when exposed to heat and ultraviolet light (sunlight). Cadmium-based stabilizers are usually prepared by mixing barium, lead, or zinc organic salts with cadmium organic salts. The products are highly effective, long-life stabilizers with no adverse effect on PVC processing. Cadmium stabilizers also ensure that PVC develops good initial color and clarity, allow high processing temperatures, and ensure a longer service life for the PVC. The stabilizers contain 1 to 15 percent cadmium; the stabilized PVC contains about 0.5 to 2.5 percent cadmium.<sup>9</sup>

#### Process Description

Cadmium stabilizer production can be a highly variable process because many of the stabilizers are custom blended for specific applications.

Liquid stabilizers (1 to 4 percent cadmium) are produced by dissolving cadmium oxide in a heated solution of the appropriate, long-chain fatty acid (e.g., 2-ethylhexanoic [for cadmium octoate] or decanoic) and an inert organic solvent. After the slow acid-base reaction, the solution is heated to drive off the water produced. The remaining product is filtered and the cadmium soap solution is packaged in drums for sale. In 1983, liquid stabilizers represented about 67 percent of the cadmium stabilizer market. However, powdered stabilizer production offers more opportunities for cadmium emissions.<sup>5,8</sup>

A process flow diagram for manufacture of powdered cadmium stabilizers is illustrated in Figure 4-3. The reactants are prepared by treating the appropriate organic acid (e.g. stearic or lauric acid) with caustic soda ( $\text{Na}_2\text{CO}_3$ ) to produce a soluble



4-23

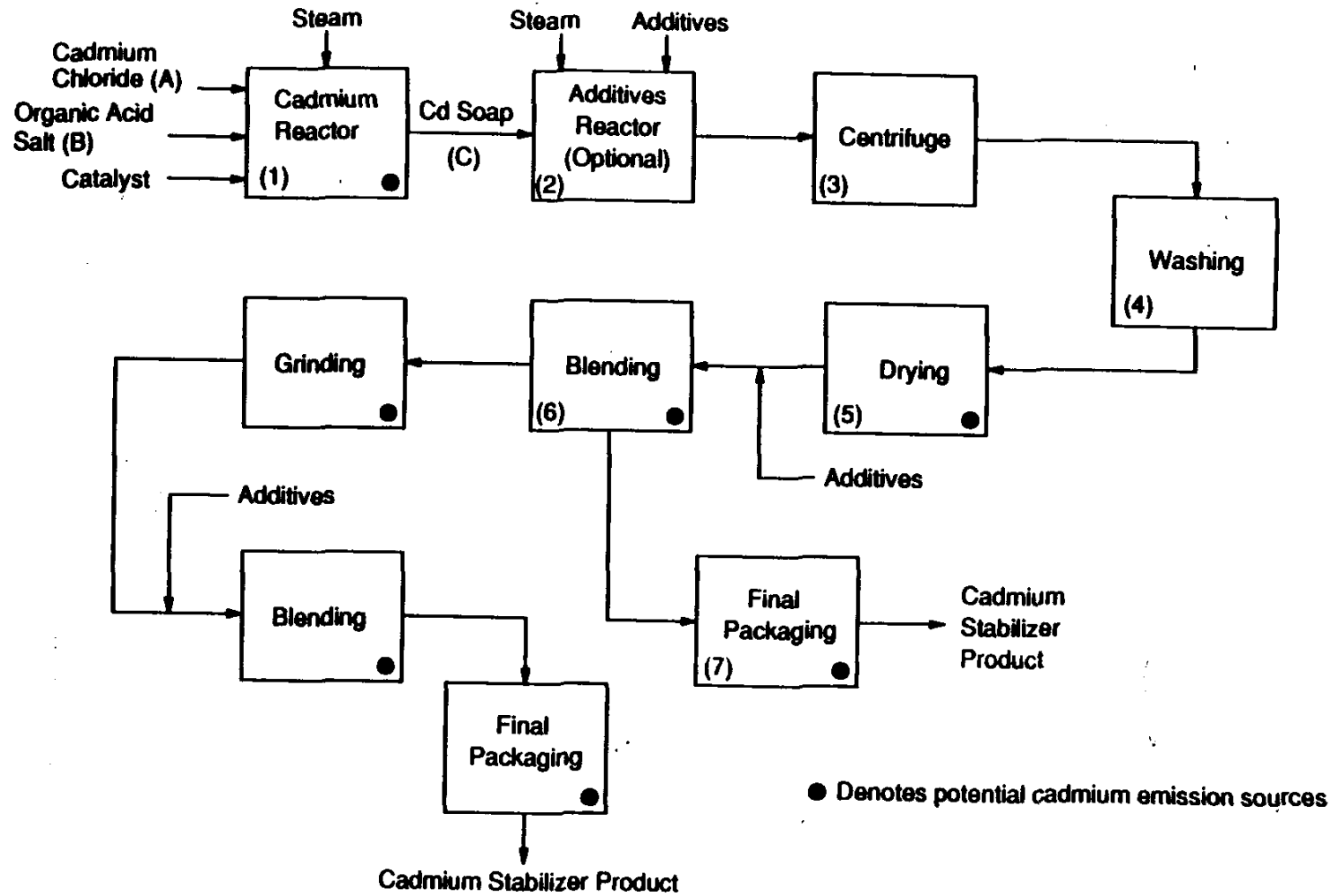

Figure 4-3. General flowsheet for the production of powdered cadmium stabilizers.<sup>14</sup>

sodium soap (Stream A). A cadmium chloride solution (Stream B) is prepared by dissolving cadmium metal or CdO in hydrochloric acid. The sodium salt of the organic acid (the soluble soap) (Stream A) is added to the cadmium chloride solution (Stream B) in the cadmium reactor (Step 1) at an elevated temperature (provided by addition of steam) in the presence of a catalyst to precipitate the cadmium soap (Stream C). Step 2 probably involves the addition of the barium organic salt or its precursor reactants. The resultant slurry is routed to a centrifuge and dewatered (Step 3). The solid soap is washed, dried, possibly blended, and packaged (Steps 4-7). The final powdered stabilizer product contains 7 to 15 percent cadmium. Additives and moistening agents can be blended with the soap as necessary to produce a particular end product. The number and sequence of blending, grinding, and packaging operations vary with the final product.<sup>8</sup>

### Emission and Controls

Cadmium emission sources and controls during cadmium stabilizer manufacture are summarized in this section. The charging of powdered cadmium oxide to the organic acid solution is a potential cadmium emission source from liquid cadmium stabilizer production. This process is typically controlled by a wet scrubber. Fugitive emissions are captured by hooding, which is either ducted to baghouses or vented to the air.<sup>5,8</sup>

Potential cadmium emission sources during powdered stabilizer production include cadmium oxide production, charging cadmium oxide to the reactor (Step 1), drying (Step 5), blending (Step 6), grinding (at one facility), weighing, and packaging (Step 7) of the final product. The cadmium oxide production process (one facility) is controlled by a baghouse. Reactors are controlled by wet scrubbers. Drying operations are generally uncontrolled.

Grinding, blending, weighing, and packaging operations are controlled by hooding and baghouses.<sup>5,8</sup>

Table 4-9 lists the manufacturers of organic chemicals who reported cadmium emissions in the 1990 Toxic Chemicals Release Inventory. The total for all plants producing stabilizers in Table 4-9 is 3.33 Mg (3.67 tons).

For similar reasons described above for cadmium pigment manufacturers, emission factors could not be calculated for individual process steps.

#### OTHER CADMIUM COMPOUND PRODUCTION

The production processes used to produce cadmium pigments and stabilizers, CdS, CdSO<sub>4</sub>, and cadmium oxide have been described above. Rather than describe the production of a large number of other cadmium compounds, production processes are described only for a few of the other compounds whose manufacturers reported cadmium emissions in the 1990 Toxic Chemicals Release Inventory.<sup>7</sup> The cadmium compounds described and their uses are listed in Table 4-10.

#### Process Descriptions

Cadmium hydroxide, Cd(OH)<sub>2</sub>, is produced by adding a solution of cadmium nitrate, Cd(NO<sub>3</sub>)<sub>2</sub>, to a boiling solution of sodium or potassium hydroxide (NaOH or KOH). The cadmium metal, oxide, hydroxide, or carbonate is digested with nitric acid followed by crystallization to produce cadmium nitrate.<sup>12</sup>

Hydrated amorphous cadmium carbonate, CdCO<sub>3</sub>, is precipitated from cadmium salt solutions by adding sodium or potassium carbonate. Heating amorphous cadmium carbonate with ammonium

TABLE 4-9. MANUFACTURERS OF ORGANIC COMPOUNDS REPORTING CADMIUM EMISSIONS IN THE 1990 TOXIC CHEMICALS RELEASE INVENTORY

| Plant  | Emissions, kg (lb) |                |                  | Monitoring data   |
|--|--------------------|----------------|------------------|-------------------|
|  | Nonpoint           | Point          | Total            |                   |
| *Akzo Chemical Inc., Interstab Div.,<br>New Brunswick, New Jersey (compounds<br>Ba Cd stabilizers)                               | 0                  | 226<br>(500)   | 226<br>(500)     | no                |
| *Argus Division, Witco<br>Corp., Brooklyn, New York<br>(Ba Cd vinyl heat stabilizers)  | 2,180<br>(4,805)   | 342<br>(755)   | 2,522<br>(5,560) | no                |
| *Ferro Corporation,<br>Bedford, Ohio<br>(Cadmium octoate, PVC stabilizers)   | 113<br>(250)       | 113<br>(250)   | 226<br>(500)     | no                |
| Rohm & Haas Delaware<br>Valley, Inc., Bristol, Pennsylvania (also<br>reported under SIC 2821, Plastics<br>materials, and resins) | 2<br>(5)           | 0              | 2<br>(5)         | yes<br>(nonpoint) |
| *Synthetic Products Co.,<br>Stratford, Connecticut<br>(compounds Ba Cd<br>stabilizers)   | 1<br>(1)           | 113<br>(250)   | 114<br>(251)     | no                |
| *Synthetic Products Co.,<br>Cleveland, Ohio<br>(Cadmium stearate)  | 113<br>(250)       | 113<br>(250)   | 225<br>(500)     | no                |
| *Vanderbilt Chemical Corp.,<br>Bethel, Connecticut<br>(Cadmium diethyldithio-carbamate)  | 1<br>(3)           | 13<br>(28)     | 14<br>(31)       | no                |
| TOTAL  | 2,410<br>(5,314)   | 920<br>(2,033) | 3,330<br>(7,347) |                   |

\*Assumed to be cadmium stabilizer manufacturers.

Source: References 7 and 10.

TABLE 4-10. OTHER CADMIUM COMPOUNDS AND THEIR USES

| Compound                   | Uses   |
|----------------------------|--|
| $\text{Cd}(\text{OH})_2$   | Used to prepare negative electrodes for nickel-cadmium batteries.  |
| $\text{Cd}(\text{NO}_3)_2$ | Imparts a reddish-yellow luster to glass and porcelain ware.   |
| $\text{CdCO}_3$            | Starting compound to produce other cadmium salts.  |
| $\text{Cd}(\text{CN})_2$   | Used in copper bright electroplating; byproduct of cadmium electroplating.   |
| $\text{CdCl}_2$            | Used in photography, dyeing, calico printing, and solutions to precipitate sulfides.   |
| $\text{CdI}_2$             | Used in photography and process engraving.   |
| $\text{CdTe}$              | Used for semiconductors and photoconductors in solar cells, and infrared, nuclear-radiation, and gamma-ray detectors.          |
| $\text{CdSe}$              | Used for semiconductors and photoconductors; noted for fast response time and high sensitivity to longer wavelengths of light. |

Source: Reference 11

chloride at 150° to 180°C (302°F to 356°F) in the absence of oxygen gives the crystalline form. Anhydrous cadmium carbonate is prepared by adding excess ammonium carbonate to a cadmium chloride solution followed by drying the precipitate at 100°C (212°F).<sup>12</sup>

Cadmium cyanide can be formed in-situ as a by-product by dissolving cadmium oxide in excess sodium cyanide electroplating solution.<sup>12</sup>

Hydrated cadmium chloride,  $\text{CdCl}_2 \cdot 5\text{H}_2\text{O}$  can be prepared by reactions in aqueous solution between hydrogen chloride,  $\text{HCl}$ , and cadmium metal or a compound such as  $\text{CdCO}_3$ ,  $\text{CdS}$ ,  $\text{CdO}$ , or  $\text{Cd}(\text{OH})_2$ . The reaction solution is then evaporated to recover crystals of the hydrated salt.<sup>12</sup>

Anhydrous cadmium chloride,  $\text{CdCl}_2$ , may be prepared by several methods:<sup>12</sup>

1. Refluxing the hydrate with thionyl chloride,  $\text{SOCl}_2$ .
2. Calcining the hydrate (removes  $\text{H}_2\text{O}$ ) in an atmosphere of  $\text{HCl}$  gas.
3. Chlorinating dry cadmium acetate,  $\text{CdO}_2\text{CCH}_3$ , with acetyl chloride,  $\text{CH}_3\text{COCl}$ , in glacial acetic acid ( $\text{CH}_3\text{CO}_2\text{H}$ )
4. Mixing hydrated cadmium nitrate,  $\text{Cd}(\text{NO}_3)_2 \cdot 4\text{H}_2\text{O}$ , with hot concentrated hydrochloric acid and removing  $\text{CdCl}_2$  by distilling the solution.
5.  
Treating cadmium metal with chlorine gas.
6.  
Treating cadmium metal with hydrogen chloride gas.

Cadmium iodide,  $\text{CdI}_2$ , is prepared by dissolving cadmium metal or a compound such as  $\text{CdO}$ ,  $\text{Cd}(\text{OH})_2$ , or  $\text{CdCO}_3$  in hydroiodic acid

(HI). The beta form is recovered by slow crystallization from solutions or from fused salt mixtures.<sup>12</sup>

Cadmium telluride, CdTe, may be produced by one of three processes:<sup>12</sup>

1. Combining elemental cadmium and tellurium at high temperatures
2. Treating solutions of cadmium salts with hydrogen telluride gas (H<sub>2</sub>Te)
3. Treating solutions of cadmium salts with an alkali telluride (e.g., with Na<sub>2</sub>Te or K<sub>2</sub>Te).

Producers of cadmium chemicals not discussed in other subsections are listed in Table 4-12.

#### Emissions and Controls

Information on emissions and controls in place at these plants was not readily available. Cadmium emissions might be expected from processes in which solutions are heated and in drying operations. However, only three of the producers listed in Table 4-11 were found in the 1990 Toxic Chemicals Release Inventory, and only one of them reported cadmium emissions (see Table 4-12).<sup>7</sup> Emission factors were not found for production of the cadmium chemicals discussed in this subsection.

TABLE 4-11. CADMIUM COMPOUND MANUFACTURERS (OTHER THAN CADMIUM OXIDE, PIGMENTS, AND STABILIZERS)

| Producer/location   | Compounds   |
|---|---|
| Air Products and Chemicals, Inc., Industrial Gases Division Specialty Gas Dept., Hometown, PA               | (C <sub>2</sub> H <sub>5</sub> ) <sub>2</sub> Cd (diethylcadmium)<br>(CH <sub>3</sub> ) <sub>2</sub> Cd (dimethylcadmium) |
| ASARCO, Inc.<br>Denver, CO  | CdS   |
| J. T. Baker, Inc.<br>Phillipsburg, NJ   | CdCl <sub>2</sub> , CdSO <sub>4</sub>   |
| Chemtech Industries, Inc.<br>Harstan Division, St. Louis, MO  | CdCl <sub>2</sub> , Cd(BF <sub>4</sub> ) <sub>2</sub> , CdSO <sub>4</sub>   |
| W. A. Cleary Corp., Somerset, NJ  | CdCl <sub>2</sub>   |
| Deepwater, Inc., Carson, CA   | CdI <sub>2</sub>  |
| Eagle Picher, Miami, OK   | CdS, CdTe   |
| Engelhard Corp., Catalysts and Chemicals Division, Cleveland, OH  | CdCl <sub>2</sub> , Cd(BF <sub>4</sub> ) <sub>2</sub> , CdSO <sub>4</sub> , CdWO <sub>4</sub>                             |
| GE Lighting Components<br>Marketing and Sales Operation, Cleveland, OH                                      | CdSe, CdS   |
| Hall Chemical Company,<br>Arab, AL  | Cd(NO <sub>3</sub> ) <sub>2</sub>   |
| Johnson Matthey, Danvers, MA  | CdTe  |
| McKenzie Chemical Works, Inc.<br>Bush, LA   | Cd acetylacetonate  |
| Morton International, Inc., Specialty Chemicals Group, Advanced Materials, CVD, Inc. subsidiary, Woburn, MA | CdS, (CH <sub>3</sub> ) <sub>2</sub> Cd   |
| Philipp Brothers Chemicals, Inc., C. P. Chemicals Subsidiary<br>Sewaren, NJ<br>Sumter, NC                   | Cd(BF <sub>4</sub> ) <sub>2</sub><br>Cd(NO <sub>3</sub> ) <sub>2</sub>  |
| Shepherd Chemical Company,<br>Cincinnati, OH  | Cd(CO <sub>3</sub> ) <sub>2</sub> , Cd(OH) <sub>2</sub> , Cd(NO <sub>3</sub> ) <sub>2</sub>                               |
| R. T. Vanderbilt, Inc.,<br>Vanderbilt Chemical Corp. Subsidiary,<br>Bethel, CT                              | Cd diethyldithiocarbamate   |

Source: Reference 3.



TABLE 4-12. MANUFACTURERS OF INORGANIC COMPOUNDS REPORTING CADMIUM EMISSIONS IN THE 1990 TOXIC CHEMICALS RELEASE INVENTORY

| Plant   | Emissions, kg (lb) |          |            | Monitoring Data |
|---|--------------------|----------|------------|-----------------|
|   | Nonpoint           | Point    | Total      |                 |
| American Microtrace Corp., Fairbury, Nebraska (micronutrients for agriculture) <sup>a</sup> | 0.5<br>(1)         | 2<br>(4) | 2.5<br>(5) | no              |
| CP Chemicals Inc. Sumter, South Carolina (Cadmium nitrate)                                  | 0                  | 0        | 0          | no              |
| Hall Chemical Company, Arab Plant, Arab, Alabama (Cadmium nitrate)                          | 0                  | 0        | 0          | no              |
| Shepherd Chemical Company, Cincinnati, Ohio (Cadmium carbonate, hydroxide, nitrate)         | 0                  | 0        | 0          | no              |
| TOTAL   | 0.5<br>(1)         | 2<br>(4) | 2.5<br>(5) |                 |

<sup>a</sup>May produce zinc sulfate from slab zinc, galvanizer's dross, or baghouse dust from the brass industry contaminated with traces of cadmium.<sup>2,13</sup> Zinc sulfate capacity of the plant is 20,000 Mg (36 percent Zn).<sup>3</sup>

Source: References 3, 6, and 9.

## REFERENCES

1. Emission Standards and Engineering Division. Cadmium Emissions from Cadmium Refining and Primary Zinc/Zinc Oxide Smelting -- Phase I Technical Report. EPA-450/3-87-011. Office of Air Quality Planning and Standards, U. S. Environmental Protection Agency, Research Triangle Park, North Carolina. June 1987.
2. Jolly, J. H. Zinc. (In) Minerals Yearbook 1989. Volume I. Metals and Minerals. Bureau of Mines, U. S. Department of the Interior, U. S. Government Printing Office, Washington, D. C. 1991. pp. 1145-1174.
3. SRI International. 1991 Directory of Chemical Producers: United States of America. SRI International, Menlo Park, California. 1991. pp. 516, 571, 582, 869-871, 946.
4. JACA Corporation. Analysis and Alternatives - Air Emissions Control Study - ASARCO Globe Plant, Denver, Colorado. Final Report. Prepared for the Colorado Department of Health. August 6, 1992.
5. Radian Corporation. Background Information Document for Cadmium Emission Sources. DCN No. 85-203-012-23-06, EPA Contract No. 68-02-3818, Assignment 23. Pollutant Assessment Branch, U. S. Environmental Protection Agency, Research Triangle Park, North Carolina. May 1985. pp. 39-56, 174, 197-212.
6. Midwest Research Institute. Big River Zinc Corporation. Assessment of Cadmium and Arsenic Emissions. EPA Contract No. 68-02-4395 (MRI Project No. 8986-28). Prepared for Air and Radiation Branch, U. S. Environmental Protection Agency, Region V, Chicago, Illinois, and Division of Air Pollution Control, Illinois Environmental Protection Agency, Springfield, Illinois. September 1989. 38 pp.
7. U. S. Environmental Protection Agency. 1990 Toxic Chemicals Release Inventory. Office of Toxic Substances, Washington, DC. January 1993.
8. Emission Standards Division. Cadmium Emissions from Pigment and Stabilizer Manufacturing -- Phase I Technical Report. Office of Air Quality Planning and Standards, U. S. Environmental Protection Agency, Research Triangle Park, North Carolina. June 1988.

9. Cadmium Association/Cadmium Council. Technical Notes on Cadmium. Cadmium Production, Properties and Uses. Cadmium Association, London; Cadmium Council, New York, New York. 1991. 8 pp.
10. 1991 Thomas Register of American Manufacturers. Thomas Publishing Company, New York, New York. 1991.
11. McGraw-Hill Dictionary of Scientific and Technical Terms, Third Edition. Sybil P. Parker, Editor in Chief. McGraw-Hill, New York, New York. 1984.
12. Parker, P.D. Cadmium Compounds. (In) Kirk-Othmer Encyclopedia of Chemical Technology. Volume 4. 3rd Ed. M. Grayson, ed. A Wiley-Interscience Publication, John Wiley and Sons, New York, New York. 1978. pp. 397-411.
13. Mumma, C., K. Bohannon, and F. Hopkins. Chemical Technology and Economics in Environmental Perspectives. Task VI - Cadmium in Phosphate Fertilizer Production. EPA 560/2-77-006. Office of Toxic Substances, U. S. Environmental Protection Agency. Washington, D. C. November 1977. 35 pp.

## SECTION 5

### EMISSIONS FROM MAJOR USES OF CADMIUM

Emissions from industrial processes that use cadmium are discussed in this section. Based on the 1991 U.S. industrial demand figures presented in Figure 3-1, Section 3, cadmium and cadmium compounds have four major commercial uses. These are: (1) electroplating, (2) secondary (i.e., rechargeable) battery manufacture, (3) heat stabilizers for synthetic materials and plastic resins, and (4) pigments for plastic products. This section is divided into four subsections, one devoted to each major use. Each subsection presents a brief introduction to the industry and a general discussion of the production process. Where cadmium is used in the process, descriptions of existing cadmium emission control measures and estimates of cadmium emission factors are given. The level of detail will vary according to the availability of information, particularly for emissions where data may be incomplete or absent.

#### CADMIUM ELECTROPLATING

In 1991, cadmium electroplating applications accounted for approximately 20 percent of the total demand for cadmium.<sup>1</sup> In cadmium electroplating, a thin layer of cadmium is deposited directly over a base metal (usually steel) to provide corrosion protection, a low coefficient of friction, and a low electrical contact resistance. In addition, cadmium coatings also are used in the electrical industry because cadmium is easily soldered. Cadmium electroplating is performed on such items as aircraft

fasteners, cable connectors for computers, ship components, and automobile engine components. Table 5-1 presents the major market areas for cadmium coatings.<sup>2</sup>

An estimated 1,200 metal finishing job shops that perform cadmium electroplating operate in the United States.<sup>3</sup> Metal finishing shops are typically located at or near the industries they serve. Therefore, the geographical distribution of the metal finishing shops closely follows that of the manufacturing base in the U.S.<sup>3</sup>

### Process Description

A flow diagram for a typical cadmium electroplating process is presented in Figure 5-1. Prior to plating, the parts undergo a series of pretreatment steps to smooth the surface of the part and to remove any surface soil, grease, or oil. Pretreatment steps include polishing, grinding, and/or degreasing of the part to prepare for plating. The part being plated is rinsed after each step in the process to prevent carry-over of solution that may contaminate the baths used in successive process steps.

Polishing and grinding are performed to smooth the surface of the part. Degreasing is performed either by dipping the part in organic solvents or by vapor degreasing the part using organic solvents. Vapor degreasing is typically used when the surface loading of oil or grease is excessive. The two organic solvents most commonly used for cleaning applications are trichloroethylene and perchloroethylene.

Alkaline cleaning is sometimes used to dislodge surface soil and prevent it from settling back onto the metal. These cleaning solutions are typically made up of compounds, such as sodium carbonate, sodium phosphate, and sodium hydroxide; they usually

TABLE 5-1. MARKET AREAS FOR CADMIUM COATINGS<sup>a</sup>

| Market area                    | Percentage of all cadmium coating products, % |
|--------------------------------|---|
| Electronics and communications | 22.5  |
| Automotive parts               | 30.0  |
| Aircraft/aerospace fasteners   | 12.5  |
| Industrial fasteners           | 17.5  |
| Ordinance                      | 6.0   |
| Shipbuilding                   | 5.0   |
| Hardware (hinges, etc.)        | 2.5   |
| Railroad and other             | 2.5   |
| Household appliances           | 1.5   |

Source: Reference 2.

<sup>a</sup>Based on 1989 data.

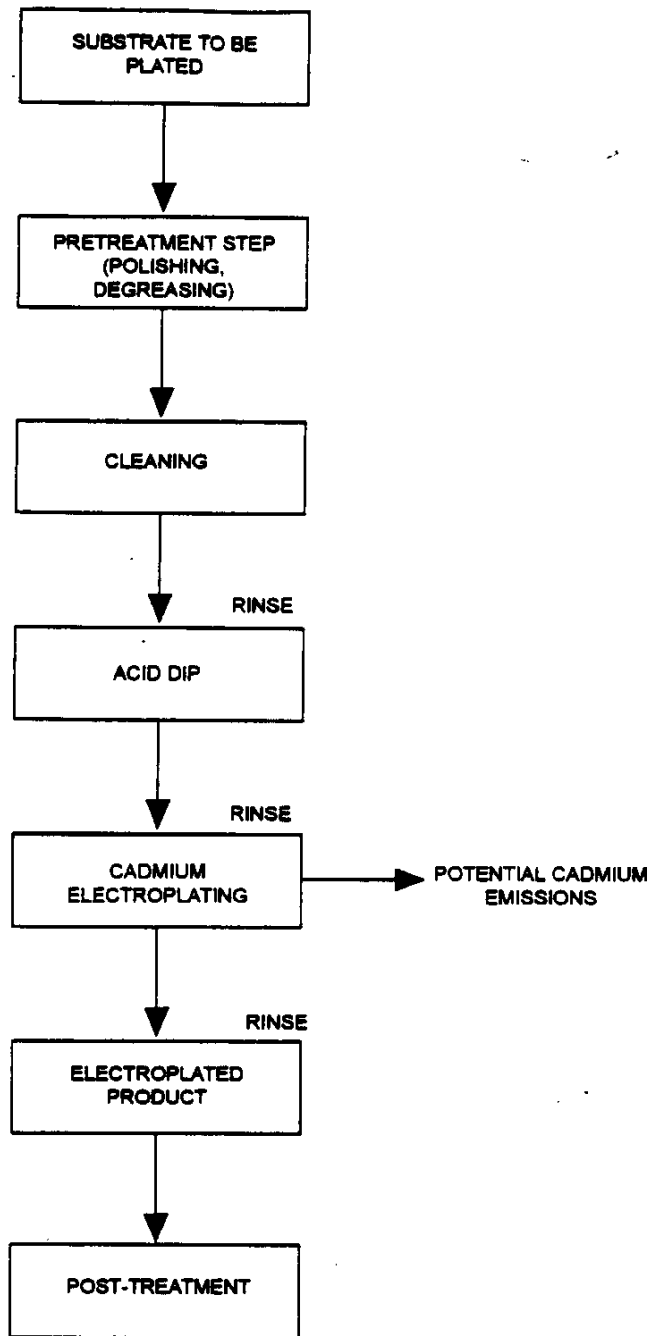

Figure 5-1. Cadmium electroplating process.

contain a surfactant. Alkaline cleaning techniques include soaking and cathodic and anodic cleaning.

Acid dips may be used to remove any tarnish or oxide films formed in the alkaline cleaning step and to neutralize the alkaline film. Acid dip solutions typically contain from 10 to 30 percent by volume hydrochloric or sulfuric acid in water.

The exact pretreatment steps used depend upon the amount of soil, grease, or oil on the parts. Following pretreatment, the parts are transferred to the plating tank.

Several cadmium plating bath formulations are used to deposit cadmium on the base metal or part; however, the cadmium cyanide bath is the predominant formulation used to deposit cadmium. Other bath formulations used include a neutral sulfate, an acid fluoroborate, or an acid sulfate bath. Currently, the use of these other bath formulations is not appreciable because the cadmium deposits formed from these baths are not of sufficient quality (i.e., do not display the desired physical properties) to gain widespread acceptance. Therefore, the following discussion will focus on the cadmium cyanide plating bath.

Table 5-2 presents the bath composition and operating parameters of the cadmium cyanide bath.<sup>4</sup> In cadmium plating, the part(s) is placed in a tank and connected into the electrical circuit as the cathode. If small parts are to be plated, the parts are first placed in a plating barrel or on a plating rack. The barrel or plating rack is then placed in the tank and connected into the electrical circuit. As current is applied, cadmium ions in the solution are drawn to the negatively-charged cathode where they undergo reduction, resulting in the cadmium being deposited on the part. The efficiency of the plating bath is based on the amount of current that is consumed in the



TABLE 5-2. COMPOSITION AND OPERATING PARAMETERS OF CADMIUM CYANIDE PLATING BATH

| Component  | Operating range |
|--|-----------------|
| <u>Composition of bath, g/L (oz/gal)</u>               |                 |
| Cadmium  | 20 (2.7)        |
| Cadmium oxide  | 22 (3.0)        |
| Sodium carbonate                                       | 30-60 (4.0-8.0) |
| Sodium cyanide   | 101 (13.5)      |
| Sodium hydroxide                                       | 14 (1.9)        |
| <u>Operating parameters</u>                            |                 |
| Current density, A/m <sup>2</sup> (A/ft <sup>2</sup> ) | 54-970 (5-90)   |
| Temperature, °C (°F)                                   | 15-38 (60-100)  |
| Cathode efficiency, %                                  | 90-95           |
| Type of anodes used                                    | Cadmium         |
| Anode efficiency, %                                    | 100             |

Source: Reference 4.

deposition reaction versus the amount of current that is consumed by other side reactions. For cadmium plating baths, the cathode efficiency typically ranges between 90 to 95 percent; therefore, 90 to 95 percent of the current supplied to the tank is consumed in the deposition reaction. The remaining 5 to 10 percent is consumed by other side reactions, such as the evolution of hydrogen gas at the cathode and the evolution of oxygen gas at the anode.

Following plating, the part is thoroughly rinsed. Most cadmium plated products do not require any further treatment; however, some parts are often post-treated with a bright dip. This dip is a chromate conversion coating, which is colored, painted, or lacquered, depending upon the part specifications.

#### Emission Control

No air pollution control measures are currently being used on cadmium electroplating tanks. Local exhaust ventilation is

sometimes used on these tanks as a precautionary measure against worker exposure.

### Emissions

Based on the ventilation guidelines published by the American National Standards Institute (ANSI), the emission potential from cadmium electroplating tanks is extremely low. Cadmium cyanide electroplating tanks are given a hazardous classification of D-4, the lowest possible rating.<sup>5</sup> In the 1990 Toxic Chemical Release Inventory (TRI), 41 facilities reported cadmium emissions under SIC 3471, Plating and Polishing.<sup>6</sup> Total cadmium emissions reported from these facilities totaled 3,324 Mg (3,656 tons). However, it should be noted that 25 percent of the facilities account for 98 percent of the emissions. Fifty percent of the facilities reported zero emissions, and 25 percent reported less than 10 lb/yr of cadmium emissions. A review of the facilities with the higher emission estimates revealed that some of the facilities were manufacturers of plating bath chemicals and not cadmium plating facilities. No additional data are available regarding cadmium emissions from cadmium electroplating tanks.

### SECONDARY BATTERY MANUFACTURE

Cadmium is used in the production of several types of secondary (rechargeable) batteries. In 1991, this area accounted for approximately 45 percent of the total demand for cadmium.<sup>1</sup> This subsection focuses on emissions and controls during production of nickel-cadmium batteries, the largest segment of the cadmium battery industry. Other battery types that use cadmium include silver-cadmium batteries, which have aerospace applications, and mercuric oxide-cadmium button cells. Information was not available on the potential for cadmium emissions from these other battery types.

Nickel-cadmium cells are manufactured in a variety of forms and sizes for principally two applications: industrial and portable batteries. Nickel-cadmium batteries for industrial use are usually the vented (or open) or semi-sealed type and may be either pocket plate, sintered plate, or fiber structured construction. Vented (open) cell designs are currently used for larger-sized cells designed for industrial or other heavy duty applications. In these applications, the batteries are subject to frequent charging and require addition of electrolytes after long periods of operation. Applications for the industrial batteries include several railway uses (e.g., locomotive starting, emergency braking, signals and warning lights), standby power for alarm systems, emergency lighting, military communications, solar energy storage, navigation equipment, hospital operating rooms, and aeronautical applications.<sup>7</sup>

Sealed-cell nickel-cadmium batteries designed for portable applications (e.g., toys, camcorders, portable tools, and cellular telephones) usually are constructed using sintered plate electrodes. These cells are manufactured in cylindrical, button, and prismatic shapes; they may be recharged up to 2,000 times, and require no maintenance.<sup>7</sup>

Eight primary producers, their plant locations, battery type, and processes used were identified in an EPA report.<sup>8</sup> The information on company name and plant locations was updated using emission reports from the 1990 TRI and is presented in Table 5-3.<sup>6</sup> In addition to these primary producers, some companies may assemble nickel-cadmium batteries using imported components.

TABLE 5-3. NICKEL-CADMIUM BATTERY PRODUCERS--1990

| Company   | Battery type |        | Process       |        |
|---|--------------|--------|---------------|--------|
|   | Sealed       | Vented | Sintered      | Pocket |
| Eagle-Picher Industries, Inc.,<br>Colorado Springs, CO            | x            |        | Wet           |        |
| Eveready Battery Company, Inc.<br>Cleveland, OH<br>Greenville, NC | x            | x      | Dry           | x      |
| Gates Energy Products, Inc.<br>Gainesville, FL                    | x            | x      | Wet           |        |
| GNB Industrial Battery Company<br>Ft. Smith, AR<br>Kankakee, IL   | x<br>x       |        | x<br>x        | x<br>x |
| Marathon Power Technologies<br>Waco, TX                           | x            | x      | Assembly only |        |
| Saft America, Inc.<br>Valdosta, GA                                | x            | x      | Wet           |        |

Source: References 6 and 8.

Process Description

Nickel-cadmium cells utilize a reversible electrochemical reaction between cadmium and nickel electrodes packed in an alkaline electrolyte (potassium or lithium hydroxide). The electrolyte does not take part in the charge/discharge reactions; it acts only as a charge carrier. During discharge, the cadmium is oxidized to cadmium hydroxide at the cathode, and hydrated nickel (III) oxide is reduced to nickel (II) hydroxide at the anode. The principal difference between the various types of nickel-cadmium cells is the nature of the cell electrodes. Three types of positive electrodes (anodes) are used: pocket plate, sintered plate, or fiber plate. The hydrated nickel oxide at the anode is usually in powder form and is held in pocket plates or suspended in a gel or paste and placed in sintered or fiber electrodes. Negative electrodes (cathodes) use pocket plate,

sintered powder, fiber plate, foam or plastic banded supports to hold the cadmium hydroxide in place. Graphite or iron oxide is commonly added to improve the conductivity of both the nickel and cadmium hydroxide.<sup>7</sup>

A description of the sintered plate wet process for nickel-cadmium battery production is presented in this subsection. A flow diagram for the process is shown in Figure 5-2. This process appears to have the greatest potential for cadmium emissions as reported by the industry in the 1990 TRI survey.<sup>6</sup> Descriptions were not available for the other production processes.

In sintered-plate formation, nickel powder is heated on a nickel-plated steel strip to give a porous medium bound to a base. Heating the nickel powder at high temperatures welds together the contact points of the nickel powder grains. During the impregnation steps, solutions of nickel or cadmium impregnate the void spaces of the sintered nickel. During the nickel impregnation, the sintered plate is soaked with a saturated solution of nickel nitrate in nitric acid. The cadmium impregnation step is similar, except that the saturated solution contains cadmium nitrate. The cadmium nitrate solution may be prepared onsite from cadmium oxide or purchased.<sup>9</sup>

The impregnated plates are dried and then immersed in a potassium hydroxide solution to convert the nickel and cadmium salts to their respective hydroxides. The anodes (with nickel hydroxide) and cathodes (with cadmium hydroxide) undergo a series of steps before being assembled into cells and then batteries: washing and oven drying, final caustic soak, hot deionized water rinse, forming in caustic, and final brush and rinse.<sup>8,9</sup>

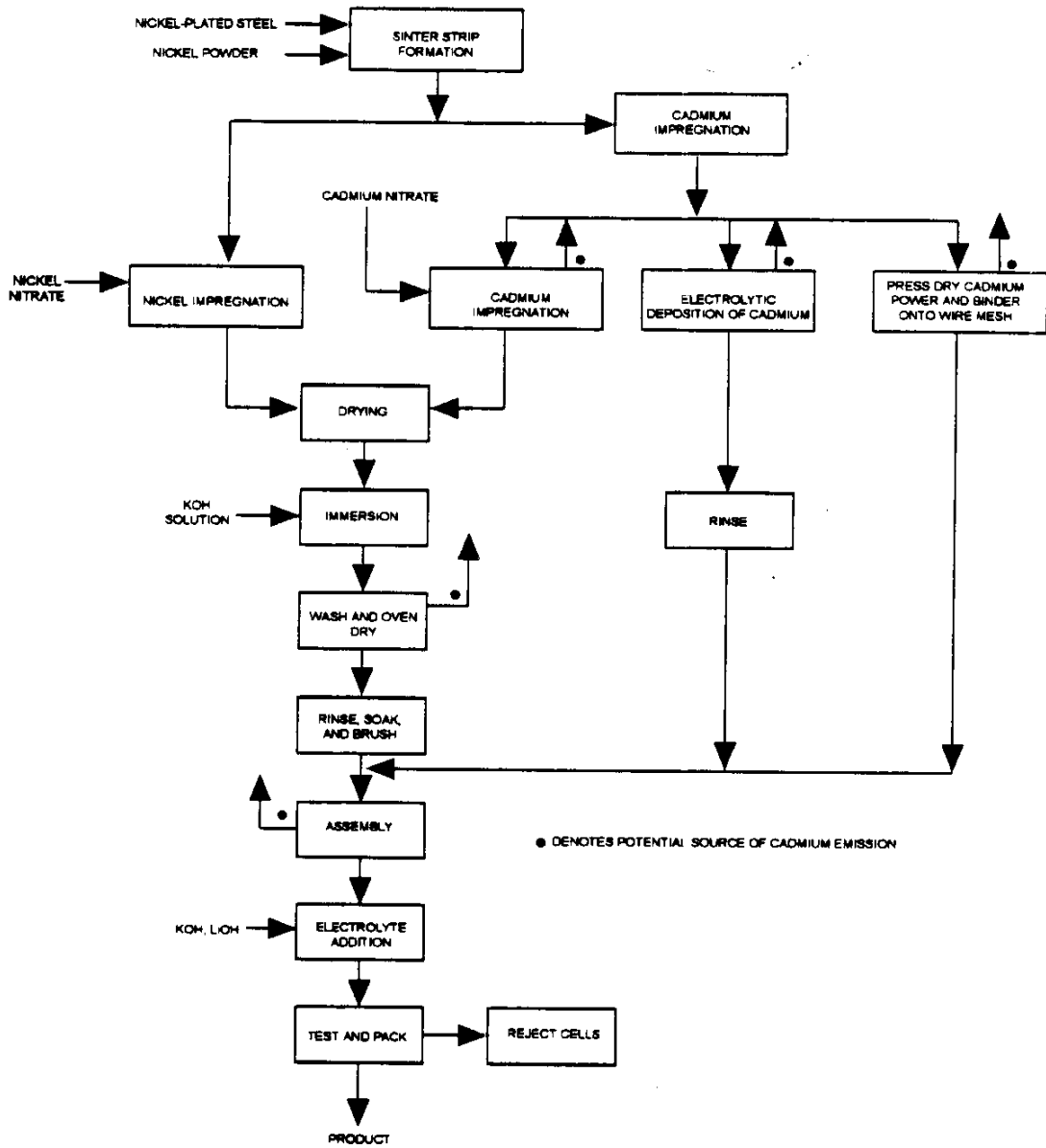
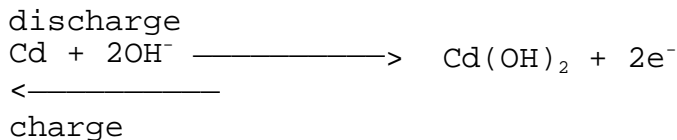

Figure 5-2. Simplified flow diagram for production of sintered plate nickel-cadmium batteries.

Two alternative methods for impregnating the cathode are used. In one method, the cadmium is electrolytically deposited from a standard cadmium electroplating solution onto the sintered plate. The cadmium-plated sintered strip is then rinsed and is ready for assembly. In another method for cathode production, dry cadmium powder and a binder are pressed on wire mesh in a mold and transferred to the assembly steps.<sup>8,9</sup> Since the individual cells are precycled before assembling into batteries, it is not important whether the cathodes are originally impregnated with Cd(OH)<sub>2</sub> (the product of discharge reactions) or Cd (the product of charging reactions). The reactions are as follows:



During assembly, the nickel-containing anode and the cadmium-containing cathodes are assembled alternately into cells with felted nylon cellulose separators, and the cells are assembled into battery cases of plastic or nickel-plated steel. The electrolyte containing potassium hydroxide and lithium hydroxide is added to the assembled components in the battery case. The separator material holds the electrolyte, as well as separates the negative and positive electrodes. The batteries finally undergo testing and packing; failed batteries are rejected.<sup>8,9</sup>

### Emission Control Measures

In a nickel-cadmium battery plant, the most common forms of cadmium emitted are cadmium nitrate, cadmium hydroxide, and

possibly cadmium oxide. All air emissions of cadmium compounds will occur as particulate matter--and primarily as fugitive emissions due to material handling and transfer procedures, oven drying operations, and cell assembly.

The predominant control methods used in the industry are:

- (1) hoods and vacuum systems ducted to dust collectors and
- (2) fabric filters in cadmium handling areas. Fabric filters are known to be highly effective particulate removal devices, especially for the lower temperature emissions anticipated for this industry. At most facilities, fugitive emissions are contained within the plant and are captured and sent to a control device.

### Emissions

Cadmium is potentially emitted from several steps in the manufacture of nickel-cadmium batteries. Potential emission sources were noted with a solid circle in Figure 5-2. Operations involving the handling of dry cadmium salts and powders, oven drying, and cell assembly are the likeliest sources.

Solution preparation is also a potential source of cadmium emissions. If the sintered plates are to be impregnated with cadmium nitrate solution, cadmium may be emitted by the handling of dry salts during solution preparation. Preparation of the cadmium-containing electrolyte for the electrolytic deposition also would emit cadmium if dry material is used. If the cathode is prepared by the dry-pressing process, handling of dry cadmium powders and pressing the cadmium powder into the grid are potential emission sources. Oven drying of cathode plate material and the cell assembly step also are potential cadmium emission sources.



No cadmium emission factors have been published for the nickel-cadmium battery production process, nor are any emission test data available that would allow the calculation of emission factors. A 1985 background document on cadmium emission sources estimated nationwide emissions from battery manufacturing at 100 kg/yr (220 lb/yr).<sup>8</sup> In the 1990 TRI, the eight battery production sites shown in Table 5-3 reported a total annual cadmium release of 316 kg (697 lb).<sup>6</sup> Based on these data, the production of nickel-cadmium batteries does not appear to be a major source of cadmium emissions.

#### CADMIUM STABILIZERS FOR PLASTICS

Cadmium compounds, in conjunction with barium compounds, have been widely used as an effective heat stabilizer system for polyvinyl chloride (PVC) and related polymers. Polyvinyl chloride is generally regarded as one of the most versatile of polymers because of its compatibility with many other materials, such as plasticizers, fillers, and other polymers. The major disadvantage is its poor thermal stability. The physical appearance and performance properties of PVC can be modified by the incorporating additives, but nothing can be done to completely prevent polymer decomposition by physical or chemical means. Additives classified as stabilizers can effectively hinder and reduce the degradation process until it essentially ceases, but a breakdown under the action of physical and chemical agents is always present to some degree. Several mechanisms have been proposed as routes for PVC destruction. These mechanisms are quite similar chemically and can be directly related to the physical state of the PVC. Dehydrochlorination is the most significant cause of degradation in PVC. The process can be initiated either by loss of a labile-chlorine atom or through a free radical reaction with the resultant formation of a double bond. As dehydrochlorination continues, conjugated double bonds

are formed, resulting in a shift in the wavelength of light absorbed by the polymer. The wavelength of absorbed light changes according to the number of conjugated double bond systems that are present, and the color of the polymer changes from light yellow to dark yellow to amber to reddish-brown and finally to black.<sup>10</sup>

Stabilizers are usually inorganic or organometallic compounds, whose names reflect the cations involved. The major classes of stabilizers are based on tin, lead, and a mixture of Group II metals, such as barium, cadmium, and zinc. The Group II metal (mixed metal) stabilizers have progressed over the years from simple additions of barium succinate and cadmium palmitate to complex blends of barium/cadmium/zinc soaps, organophosphites, antioxidants, solvents, extruders, peptizers, colorants, ultraviolet (UV) absorbers, and many other constituents. Cadmium stabilizers were initially used because they impart clarity and retention of initial color to a PVC formulation. The long-term heat stability supplied by cadmium and zinc is much less than that offered by barium compounds. Cadmium stabilizers are functionally dependent upon the anions, and the anions are a major factor that affects properties, such as lubricity, plate-out, clarity, color drift, and heat stability. Common anions for cadmium are the 2-ethylhexoate (octoate), phenate, benzoate, and stearate.<sup>10</sup>

Cadmium/barium stabilizers are commercially available in liquid or solid form. Liquid stabilizer systems are easier to handle and do not result in plate-out problems, which may occur with the powdered systems. The liquid stabilizers usually have a lower cadmium content (1 to 4 percent) and are cheaper on a weight basis. Solid stabilizers have a higher cadmium content (7 to 15 percent) and are more effective than liquid stabilizers on a weight basis.<sup>13</sup>

In these mixed metal stabilizer systems, the cadmium content ranges from 1 to 15 percent, and the stabilizer system constitutes between 0.5 to 2.5 percent of the final PVC compounded resin.<sup>7</sup> Most cadmium-containing stabilizer systems are barium/cadmium-zinc based mixtures; these systems are being replaced with barium/zinc products. The successful replacement of cadmium-containing products depends principally on the use of higher barium-to-zinc ratios than barium-to-cadmium ratios and the anion chemistry, which compensates for the smaller size of the zinc atom compared to the cadmium atom.<sup>11</sup> An estimated 30 to 35 percent of the cadmium-containing stabilizer usage in the U.S. has changed to noncadmium products, and this percentage is expected to increase to more than 50 percent by the end of 1992.<sup>12</sup>

#### Process Description

The addition of heat stabilizer additives occurs as part of the overall production of the formulated PVC resins. Formulation of the resin normally uses a blender system and, depending upon the particular PVC product, may be a batch or continuous operation. Solid cadmium stabilizer systems may be added directly to the dry PVC resin and then thoroughly mixed with the resin particles. Liquid cadmium stabilizers may be added directly to the resin or mixed with a liquid plasticizer prior to addition to the resin. The particular sequence of stabilizer addition depends upon the processing method to be used (e.g., calendaring, extrusion, dipping). After all additives, including the stabilizer have been incorporated, the formulated resin is usually a free-flowing powder or granule with the liquids adsorbed on the resin particles.

The most common usage of cadmium-based stabilizers is for flexible and semi-rigid PVC applications.<sup>11</sup> In general, cadmium-

based stabilizers are used in the production of flexible and semi-rigid PVC products. These PVC products are processed by calendering, extrusion, or injection molding techniques.<sup>10</sup> Cadmium-based stabilizers find limited use in rigid PVC products or films for electrical uses. Liquid cadmium stabilizers may be used in production of the following types of PVC products:

1. Flexible or semi-rigid injection molded;
2. Clear plastisols;
3. Thin gauge or lightly filled calendered films;
4. Clear and lightly filled extruded films or sheets; and
5. Dipping operations.

Solid cadmium-based stabilizers may be used in highly filled calendered sheet (e.g., floor tile) or other calendering, injection molding, or extrusion processes to manufacture filled (i.e., nonclear) PVC products.

#### Emission Control Measures

No information is available for the specific types of emission control devices used to control cadmium emissions resulting from production of PVC products. One manufacturing facility using cadmium stabilizers indicated that the major emission source would be due to materials handling.<sup>16</sup> This source presumably would be in the resin formulation area and if a small batch operation were used, during transfer of the formulated resin. Most solid cadmium stabilizers are produced in forms (e.g., flaxes, pellets) to reduce dust emissions during handling.

Cadmium emissions from the processes of extruding, molding, and calendering are probably minimal since the temperatures necessary to volatilize significant quantities of cadmium compounds would thermally destroy the resin and other organic constituents.

## Emissions

Cadmium emissions may occur when cadmium-containing stabilizers systems are added to PVC resins during formulation; prior to processing the PVC resin. Although use of cadmium in the production of stabilizers constitutes about 12 percent of the total demand for cadmium, the emission of cadmium resulting from the use of the stabilizers during resin formulation had not been considered a potential source. Table 5-4 presents cadmium emissions by several manufacturers of formulated resins and plastics reported in the 1990 TRI.<sup>6</sup> Some of these facilities are probably also using cadmium-based pigments in the resins, but the reporting system in the TRI does not easily distinguish between the two cadmium products. Thus, some of the cadmium emissions may result from pigment usage.

No emission factors are published for this process, and no test data are available to allow calculation of an emission factor.

### CADMIUM PIGMENTS IN PLASTICS

About 80 percent of all cadmium-based pigments is used in the plastics industry. The other 20 percent is used mostly for the coloration of paints, coatings, ceramics, and glasses.<sup>15</sup> In the plastics industry, pigments and other additives are blended with the resins before the plastics products are manufactured. This blending step can be done in conjunction with other manufacturing steps at the production site. Alternatively, custom-blended resins can be purchased from another company and transported to the production site. This is a common practice for smaller companies or for specialty products. Table 5-5 lists manufacturers of custom compound purchased resins who reported emissions of cadmium in the 1990 TRI.<sup>6</sup> Most of this group blends

TABLE 5-4. REPORTED CADMIUM EMISSIONS BY MANUFACTURERS OF FORMULATED RESINS AND PLASTIC PRODUCTS

| Company                       | Location               | Reported emissions |       |
|-------------------------------|------------------------|--------------------|-------|
|                               |                        | kg                 | lb    |
| Rohm & Haas, Inc.             | Bristol, PA            | 2                  | 5     |
| Gencorp Polymer Products      | Newcomerstown, OH      | 5                  | 10    |
| General Electric Plastics     | Selkirk, NY            | 8                  | 16    |
| Synthetic Products Company    | Stratford, CT (2)      | 118                | 261   |
|                               | Cleveland, OH          | 227                | 500   |
| Monsanto Company              | Addyson, OH            | 5                  | 11    |
| General Electric Chemicals    | Washington, WV         | 1                  | 2     |
| Huls America, Inc.            | Mountain Top, PA       | 113                | 250   |
| Franklin Burlington Plastics  | Burlington, NJ         | 227                | 500   |
| O'Sullivan Corp.              | Lebanon, PA            | 5                  | 10    |
|                               | Winchester, VA         | 5                  | 10    |
|                               | Yerington, NV          | 5                  | 10    |
| Gary Corp.                    | Leominster, MA         | 43                 | 94    |
| North American Plastics, Inc. | Prairie, MS            | 5                  | 10    |
| Vytron Corp.                  | Loudon, TN             | 113                | 250   |
| Standard Products Company     | Winnsboro, SC          | 2                  | 5     |
| RJF International Corp.       | Marietta, OH           | 5                  | 10    |
| Achilles USA, Inc.            | Everett, WA            | 16                 | 35    |
| IPC Corinth Division, Inc.    | Corinth, MS            | 113                | 250   |
| B.F. Goodrich                 | Pedricktown, NJ        | 24                 | 52    |
| Regalite Plastics Corp.       | Newton Upper Falls, MA | 5                  | 10    |
|                               | TOTAL                  | 1,047              | 2,301 |

Source: Reference 6.

Note: In addition to the companies and locations shown in the table, 16 additional companies or locations reported zero cadmium emissions.

TABLE 5-5. REPORTED CADMIUM EMISSIONS BY PRODUCERS OF  
CUSTOM COMPOUNDED RESINS

| Company                            | Location              | Emissions |       |
|------------------------------------|-----------------------|-----------|-------|
|                                    |                       | kg        | lb    |
| Plastics Color Chip, Inc.          | Ashboro, NC           | 227       | 500   |
|                                    | Calumet City, IL      | 116       | 255   |
| Vista Chemical Company             | Jeffersontown, KY     | 116       | 255   |
| Reed Plastics Corp.                | Albion, MI            | 2         | 5     |
|                                    | Holden, MA            | 2         | 5     |
| General Color and Chemical Company | Minerva, OH           | 113       | 250   |
| A. Schulman, Inc.                  | Akron, OH             | 5         | 10    |
| PMS Consolidated                   | Norwalk, OH           | 227       | 500   |
|                                    | Ft. Worth, TX         | 116       | 255   |
|                                    | Florence, KY          | 116       | 255   |
|                                    | Gastonia, NC          | 227       | 500   |
|                                    | St. Peters, MO        | 227       | 500   |
|                                    | Somerset, NJ          | 116       | 255   |
|                                    | Elk Grove Village, IL | 116       | 255   |
| Teknor Apex Company                | Pawtucket, RI         | 5         | 10    |
| Hoechst Celanese                   | Florence, KY          | 5         | 10    |
| Quantum Chemical Corp.             | Fairport Harbor, OH   | 227       | 500   |
|                                    | TOTAL                 | 1,963     | 4,320 |

Source: Reference 6.

pigments with resins.

The costs of purchasing custom compounded resins have risen to a level where some producers of plastic goods have changed to blending their own resins. This shift in production locale may be particularly true for users of cadmium pigments, because these pigments are expensive and have advantages of easy mixing and rapid, even spreading.

#### Process Description<sup>16</sup>

Most commercial pigments have an average particle size in the range of  $10^{-3}$  to  $10^{-5}$  mm (0.01 to 1.0  $\mu$ ). The dry pigment powders are usually agglomerated before sale in order to reduce material loss during transport. These agglomerates must be dispersed by the compound resin manufacturer, either before or during processing. The initial step in dry pigment dispersion is wetting of the pigment surface. Subsequent steps are breaking down of agglomerates, distribution of the particles in the resin, and stabilization of the dispersion.<sup>17</sup> Since cadmium pigment loss would be minimal after the dry pigment is wet, this discussion focuses on materials handling.

Bulk materials can be stored in outdoor silos, boxes, bags, or drums. Large vacuum pumps transport materials from railcar or truck to silos. Smaller vacuum pumps transport materials from onsite storage in bags, drums, and boxes to the hopper loaders of process machinery, if not to the machines themselves. Vacuum lines enter hoppers tangentially so that the material can be separated from the conveying air stream. An external ratio mixing valve is usually located at the inlet of each vacuum hopper to allow regrinds and other recycled material to be proportionally mixed with virgin material prior to processing.<sup>17</sup>



## Emission Control Measures

According to conversations with company officials at production plants, it was determined that cadmium emissions originate primarily from materials handling.<sup>18,19</sup>

Hand methods of blending materials can waste up to 25 percent of purchased colorants. Automatic methods, such as metering, mixing, and vacuum transport, substantially reduce waste and emissions. Emissions of powdered materials from vacuum hoppers are usually controlled with filters and floor-mounted dust collectors. All cadmium emissions, as cadmium pigments, would be in a particulate form so the use of dust filters and dust collectors should be an effective emission control measure. However, there are no test data available to substantiate the effectiveness of these controls for the cadmium pigment particulate found at these sources.

## Emissions

Emission factors are not available for pigment blending operations, which have not been recognized as a potential source of cadmium emissions in previous surveys. No test data are available that can be used to calculate emission factors.

## REFERENCES

1. 1991 Mineral Industry Surveys--Cadmium. Annual Review. Bureau of Mines, U.S. Department of Interior, Washington, DC. January 1993.
2. Kraft, G.G. "The Future of Cadmium Electroplating," Metal Finishing. Volume 88, No. 7. July 1990.
3. Finishers' Management Media/Market Bulletin. Metal Finishing Job Shop Industrial Profile...1985/86. Glenview, IL. 1986.
4. Metal Finishing. Guidebook and Directory Issue. January 1993. Volume 91, Number 1A. New York, NY.
5. American National Standard, Practices for Ventilation and Operation of Open-Surface Tanks, American National Standards Institute, New York, NY.
6. U. S. Environmental Protection Agency. 1990 Toxics Release Inventory. Office of Toxic Substances, Washington, DC. January 1993.
7. Cadmium Association/Cadmium Council. Technical Notes on Cadmium. Cadmium Production, Properties, and Uses. Cadmium Association, London; Cadmium Council, New York, NY. 1991.
8. Radian Corporation. Background Information Document for Cadmium Emission Sources. DCN No. 85-203-012-23-06, EPA Contract No. 68-02-3818, Assignment 23. Pollutant Assessment Branch, U. S. Environmental Protection Agency, Research Triangle Park, NC. May 1985.
9. Radian Corporation. Locating and Estimating Air Emissions from Sources of Nickel. EPA-450/4-84-007f. Office of Air Quality Planning and Standards, U. S. Environmental Protection Agency, Research Triangle Park, NC. March 1984.
10. Modern Plastics. Encyclopedia '92. "Chemicals and Additives: Stabilizers". Vol. 68 (11), pp. 190-192. McGraw Hill Publishing, New York, NY. October 1991.
11. Modern Plastics. Special Buyers Guide and Encyclopedia, 1993 Issue. "Additives: Heat Stabilizers." Vol. 69 (13), pp. 313-315. McGraw Hill Publishing, New York, NY. December 1992.
12. Modern Plastics. "Special Report: Chemicals and Additives." Vol. 69 (9), pp. 61-63. McGraw Hill Publishing, New York, NY. September 1992.

13. Cadmium Association/Cadmium Council. Technical Notes on Cadmium: Cadmium in Stabilizers for Plastics. Cadmium Association, London; Cadmium Council, New York, NY. 1978.
14. Telecon. Gupta, R., Midwest Research Institute with P. Vorhees, Rohm and Haas, Philadelphia, PA. Particulate emissions from the use of cadmium stabilizers in PVC. April 1992.
15. Lynch, R.F. Color It Cadmium When You Need the Best. Plastics Eng., April 1985.
16. Witlock, D.C. Materials Handling: In Modern Plastics Encyclopedia, Vol. 63 (10A), October 1986.
17. Schiek, R.C. Colorants: In Modern Plastics Encyclopedia; Vol. 63(10A). October 1986.
18. Telecon. Camp, J., Midwest Research Institute, with V. Karagan, Avecor, Inc., San Fernando, CA. April 9, 1992. Cadmium pigments materials handling during compounding with resins.
19. Telecon. Camp, J., Midwest Research Institute, with D. Frost, PMS Consolidated, Toledo, OH. April 16, 1992. Cadmium pigment materials handling during compounding with resins.

## SECTION 6

### EMISSIONS FROM COMBUSTION SOURCES

Cadmium is often found as a trace contaminant in fossil fuels or waste materials. When these materials are fed to combustion processes, the combination of the elevated temperature of the process and the relative volatility of cadmium results in cadmium being partitioned between the ash and the combustion gas exhaust stream. This section addresses cadmium emissions from seven stationary source combustion processes:

- Coal combustion
- Oil combustion
- Natural gas combustion
- Wood combustion
- Municipal waste combustion
- Sewage sludge incineration
- Medical waste incineration

These seven processes fall into two general categories. The first four involve fossil fuel combustion for energy generation, while the last three are primarily waste disposal processes, although some energy may be recovered from these processes. The paragraphs below provide a general introduction to the two combustion categories. As part of this introduction, a summary of nationwide fuel usage is presented in detail. This information was used in Section 3 to develop nationwide emissions of cadmium for different sectors and fuels. Such information is also needed to develop cadmium emission inventories for specific

areas. It is included in the introduction rather than in individual sections because (1) the individual sections are organized by fuel type rather than by use sector and (2) fossil fuel use patterns differ geographically by industry sector. The introduction also briefly describes the waste combustion category. Specific discussions for the seven source categories follow these introductory paragraphs.

In 1990, the total annual nationwide energy consumption in the United States was  $85.53 \times 10^{12}$  megajoules (MJ) ( $81.15 \times 10^{15}$  British thermal units [Btu]).<sup>1</sup> Of this total, about  $52.01 \times 10^{12}$  MJ ( $49.35 \times 10^{15}$  Btu) or 61 percent involved consumption of coal, petroleum products, and natural gas in nontransportation combustion processes. (No data were available on energy consumption for wood combustion from the United States Department of Energy.) Table 6-1 summarizes the 1990 United States distribution of fossil fuel combustion as a function of fuel in the utility, industrial, commercial, and residential sectors. The paragraphs below provide brief summaries of fuel use patterns; additional details on fuel consumption by sector for each State can be found in Reference 1.

As shown in Table 6-1, the utility sector is the largest fossil fuel energy consumer at the rate of about  $21 \times 10^{12}$  MJ ( $20 \times 10^{15}$  Btu) per year. About 80 percent of this energy was generated from coal combustion, with bituminous and lignite coal contributing substantially greater quantities than anthracite coal. In fact, Pennsylvania is the only State in which anthracite coal is used for electric power generation. Although most States relied primarily on coal for power generation, the distribution among fossil fuels varied from State to State, and several States relied heavily on natural gas and fuel oil for power generation. In California, natural gas provides about 90 percent of the fossil-fuel based electricity production, and

TABLE 6-1. DISTRIBUTION OF FOSSIL FUEL CONSUMPTION  
IN THE UNITED STATES

| Fuel                        | Annual energy consumption<br><i>10<sup>12</sup> MJ (10<sup>15</sup> Btu)</i> |                    |                  |                  |                    |
|-----------------------------|--|--------------------|------------------|------------------|--------------------|
|                             | Utilities  | Industrial         | Commercial       | Residential      | Total              |
| Bituminous/<br>lignite coal | 16.939<br>(16.071)   | 2.892<br>(2.744)   | 0.085<br>(0.081) | 0.045<br>(0.043) | 19.961<br>(18.939) |
| Anthracite coal             | 0.018<br>(0.017)   | 0.009<br>(0.009)   | 0.013<br>(0.012) | 0.019<br>(0.018) | 0.059<br>(0.056)   |
| Distillate oil              | 1.201<br>(1.139)   | 1.245<br>(1.181)   | 0.513<br>(0.487) | 0.882<br>(0.837) | 3.900<br>(3.700)   |
| Residual oil                | 0.091<br>(0.086)   | 0.436<br>(0.414)   | 0.255<br>(0.242) | -<br>-           | 0.782<br>(0.742)   |
| Other petroleum<br>fuels    | 0.026<br>(0.025)   | 7.083<br>(6.720)   | 0.197<br>(0.187) | 0.452<br>(0.429) | 8.540<br>(7.361)   |
| Natural gas                 | 3.015<br>(2.861)   | 8.925<br>(8.468)   | 2.907<br>(2.758) | 4.762<br>(4.518) | 19.609<br>(18.605) |
| Total                       | 21.290<br>(20.199)   | 20.590<br>(19.536) | 3.970<br>(3.767) | 6.160<br>(5.845) | 52.01<br>(49.35)   |

Source: Reference 1.

no coal is used. In Hawaii, fuel oil is used exclusively, while in Oklahoma and Texas, a mixture of coal and fuel oil are used. In Florida, Louisiana, Massachusetts, and New York, coal, fuel oil, and natural gas each represent a substantial fraction of the power generation. The States of Idaho, Maine, Rhode Island, and Vermont had no coal consumption. Idaho relies exclusively on hydroelectric power, while the New England States use a mixture of fuel oil, natural gas, nuclear, and hydroelectric sources.

At  $20.6 \times 10^{12}$  MJ ( $19.5 \times 10^{15}$  Btu) per year, the industrial sector is the second largest consumer of fossil fuels. This sector uses a mixture of natural gas (43 percent), fuel oil (8 percent), other petroleum fuels (34 percent), and coal (14 percent). The other petroleum fuels that are used include primarily liquified petroleum gas, asphalt and road oil, and other nonclassified fuels. Again, the distribution among the three fuel types varies substantially from State to State, with each of the three contributing significant fractions in most States. Notable exceptions are Hawaii, which relies almost exclusively on petroleum fuels; Alaska, which relies primarily on natural gas; and the northeastern States of Connecticut, New Hampshire, Rhode Island, and Vermont, which use almost no coal.

As shown in Table 6-1, substantially smaller quantities of fossil fuel are used in the commercial and residential sectors than are used in the utility and industrial sectors. The fuels used are primarily natural gas, fuel oil, and liquified petroleum gas (the "other petroleum fuels" in the residential category). Almost all States use a mixture of the fuels, but the distributions vary substantially, with some States like California and Louisiana using primarily natural gas and others like New Hampshire and Vermont using a much greater fraction of fuel oil. One unique case is Pennsylvania where anthracite coal is used in both the residential and commercial sectors.

In the individual sections below, additional information will be presented on the cadmium content of the different fuels and on the relationship between fuel type and emissions. However, for any geographic area, the contribution of energy generation sources to cadmium emissions will be a function of the distribution of fuels used in the different sectors within the area.

The sources within the second combustion category are engaged primarily in waste disposal. Cadmium emissions from these processes are related to the cadmium contaminant levels in the waste. The different waste types are generally characterized with distinct source categories. Furthermore, these waste disposal practices are not strongly related. Consequently, each of these categories will be characterized individually within the sections below rather than in a general discussion here. The eight sections below have a consistent organization. First, the characteristics of the fuel or waste are described and, in the case of the waste combustion processes, the general source category is also described. Second, process descriptions are presented and emission points are identified. Third, available emission control measures are identified and described. Finally, emission factors are presented.

## COAL COMBUSTION

As presented in Table 6-1, most coal combustion in the United States occurs in the utility and industrial sectors, with about 85 percent being bituminous and lignite combustion within the utility sector and about 14 percent being bituminous and lignite combustion in the industrial sector. Consequently, the focus of the discussion below will be on bituminous and lignite coal combustion in utility and industrial boilers. However, limited information on anthracite coal combustion will also be presented.



## Coal Characteristics

The coal characteristics of greatest interest in evaluating cadmium emissions from coal combustion are coal heating values and coal cadmium content. Cadmium emissions are a direct function of the cadmium content, while heating values are used to convert emission factors between mass input-based and heat input-based activity levels. This section briefly summarizes the information about coal heating levels and cadmium content contained in References 2 through 4. More complete summaries can be found in Reference 2, and detailed analyses of coal cadmium content as a function of coal type and geographic region can be found in References 3 and 4.

Coal is a complex combination of organic matter and inorganic ash formed in geologic formations from successive layers of fallen vegetation. Coal types are broadly classified as anthracite, bituminous, subbituminous, or lignite, and classification is made by heating values and amounts of fixed carbon, volatile matter, ash, sulfur, and moisture.<sup>5</sup> Formulas for differentiating coals based on these properties are given in Reference 6. These four coal types are further subdivided into 13 component groups. Table 6-2 summarizes information about the heating values for these component groups.<sup>2</sup>

The heating value of coal varies between coal regions, between mines within a region, between seams within a mine, and within a seam. The variability is minimal compared to that found with trace metal levels described below, but it may be important when fuel heat content is used as the activity level measure for source emission calculations. Data presented in Table 6-3 illustrate the regional variability of coal heat content. Heat content among coals from several different mines within a region appears to exhibit greater variability than either variability

TABLE 6-2. COAL HEATING VALUES

| Coal class    | Component group | Definition                 | Source <sup>a</sup>                            | Heating value, kJ/kg (Btu/lb)    |                      |
|---------------|-----------------|----------------------------|--|----------------------------------|----------------------|
|               |                 |                            |  | Range <sup>a</sup>               | Average <sup>a</sup> |
| Anthracite    | A1              | Meta-anthracite            | PA, RI   | 21,580-29,530<br>(9,310-12,740)  | 25,560<br>(11,030)   |
|               | A2              | Anthracite                 | CO, PA, NM                                     | 27,700-31,800<br>(11,950-13,720) | 30,270<br>(13,001)   |
|               | A3              | Semianthracite             | AR, PA, VA                                     | 27,460-31,750<br>(11,850-13,700) | 29,800<br>(12,860)   |
| Bituminous    | B1              | Low volatile bituminous    | AR, MD, OK, PA, WV                             | 30,640-34,140<br>(13,220-14,730) | 32,400<br>(13,980)   |
|               | B2              | Medium volatile bituminous | AL, PA, VA                                     | 31,360-33,170<br>(13,530-14,310) | 32,170<br>(13,880)   |
|               | B3              | High volatile A bituminous | AL, CO, KS, KY, MO, NM, PA, TN, TX, UT, VA, WV | 28,340-35,710<br>(12,230-14,510) | 31,170<br>(13,450)   |
|               | B4              | High volatile B bituminous | IL, KY, MO, OH, U T, WY                        | 26,190-30,480<br>(11,300-13,150) | 28,480<br>(12,290)   |
|               | B5              | High volatile C bituminous | IL, IN, IA, MI                                 | 24,450-27,490<br>(10,550-11,860) | 26,030<br>(11,230)   |
| Subbituminous | S1              | Subbituminous A            | MT, WA   | 23,940-25,820<br>(10,330-11,140) | 24,890<br>(10,740)   |
|               | S2              | Subbituminous B            | WY   | 21,650-22,270<br>(9,340-9,610)   | 21,970<br>(9,480)    |
|               | S3              | Subbituminous C            | CO, WY   | 19,280-19,890<br>(8,320-8,580)   | 19,580<br>(8,450)    |
| Lignite       | L1              | Lignite A                  | ND, TX   | 16,130-17,030<br>(6,960-7,350)   | 16,660<br>(7,190)    |
|               | L2              | Lignite B                  | NA   | NA                               | NA                   |

Source: Reference 2.

<sup>a</sup>NA = Not available.

TABLE 6-3. EXAMPLES OF COAL HEAT CONTENT VARIABILITY

| Variability           | Coal source  | Coal heat content, Btu/lb |  | Percent variation about the mean |
|-----------------------|--------------|---------------------------|--|----------------------------------|
|                       |              | Mean                      | Range  |                                  |
| Intermine variability | Eastern U.S. | 12,320                    | 10,750 - 13,891                                      | 12.7                             |
|                       | Central U.S. | 10,772                    | 9,147 - 12,397                                       |                                  |
|                       | Western U.S. | 11,227                    | 9,317 - 13,134                                       |                                  |
| Intramine variability | Eastern U.S. | 12,950                    | NA <sup>a</sup><br>9,182 - 10,834<br>11,335 - 12,665 | 4.8 <sup>b</sup>                 |
|                       |              | 10,008                    |  |                                  |
|                       |              | 12,000                    |  |                                  |
|                       | Central U.S. | 12,480                    | NA <sup>a</sup><br>9,667 - 12,284                    | 5.7 <sup>c</sup>                 |
|                       |              | 10,975                    |  |                                  |
|                       | Western U.S. | 10,351                    | 9,791 - 10,911                                       | 12.0                             |
| Intraseam variability | Eastern U.S. | 12,230                    | NA <sup>a</sup>                                      | 3.0 <sup>d</sup>                 |
|                       | Central U.S. | 10,709                    | 10,304 - 11,113                                      | 3.7                              |
|                       | Western U.S. | 11,540                    | NA <sup>a</sup>                                      | 2.5 <sup>e</sup>                 |
|                       |              |                           |  |                                  |

Source: Reference 2.

<sup>a</sup>NA = not available.

<sup>b</sup>Based on a standard deviation of 624.

<sup>c</sup>Based on a standard deviation of 708.

<sup>d</sup>Based on a standard deviation of 371.

<sup>e</sup>Based on a standard deviation of 291.

within a mine or within a seam. For the sample points presented in Table 6-3, intermine variability averaged 15 percent, intramine variability 7 percent, and intraseam variability 3 percent. Because few combustion sources burn coal from just one seam or one mine, coal heat content variability may significantly affect emission estimates that are being calculated using emission factors, coal use data, and coal heat content data, even if the source gets all its coal from the same area of the country.<sup>2</sup>

To an even greater extent than the heating value, the cadmium content of coal varies substantially among coal types, at different locations in the same mine, and across geographic regions. The most comprehensive source of information on coal composition is the United States Geological Survey (USGS) National Coal Resources Data System (NCRDS). Geochemical and trace element data are stored within the USCHEM file of NCRDS. As of October 1982, the file contained information on 7,533 coal samples representing all United States coal provinces. Trace element analysis for about 4,400 coal samples were included in the data base. This computerized data system was not accessed during the current study due to time and budgetary constraints and information from USGS that indicated that few data had been added to the system since 1972; however, a summary of the data presented in Reference 2 was reviewed. The most extensive source of published trace element data was produced by Swanson et al. of the USGS.<sup>4</sup> This report contains data for 799 coal samples taken from 150 producing mines and includes the most important United States coal seams. Data from the Swanson study was the initial input into the USCHEM file of NCRDS. The information presented here summarizes Brooks' review of the results published by White and Swanson.<sup>2-4</sup> Note that these results are consistent with unpublished analyses conducted by USGS on the data contained in NCRDS as of 1989.<sup>7</sup>

Table 6-4 presents information on the mean concentration of cadmium in coal and on the distributions of cadmium concentrations by coal type. Bituminous coals have the highest mean cadmium concentration, 0.91 parts per million by weight (ppmwt). The standard deviation of the mean, 7.3 ppmwt, exceeds the mean, indicating substantial variation within the data. Bituminous coals have the greatest reported range of cadmium concentrations (<0.02 to 100 ppmwt).<sup>2</sup> Based on conversations with USGS personnel, the means reported in Table 6-4 are regarded as typical values for in-ground cadmium concentration in coals in the United States.

The concentration of cadmium in coal also varies by geographic region from which the coal is mined. Based on the "best typical" values for each region, which are footnoted in Table 6-5, coals from the Interior Province have the highest mean cadmium concentration, 5.47 ppmwt. That study also showed that the greatest range of concentrations is found in coals from the Interior Province, with a reported range of <0.02 to 100 ppmwt. Also, based on the best available data, the lowest mean concentration is found in coals from the Appalachian region (0.13 ppmwt).<sup>2</sup> The means reported in Table 6-5 may be regarded as typical in-ground concentrations of cadmium in coals from each geographic region.

#### Process Description<sup>2,5,8</sup>

As shown in Table 6-1, almost all coal combustion occurs in utility and industrial boilers. Almost all of the coal burned is bituminous and subbituminous (95 percent) and lignite (4 percent).<sup>2</sup> However, the processes used for the different coals are comparable. The paragraphs below first describe the boilers used for bituminous coal combustion. Then, lignite and

TABLE 6-4. CADMIUM CONCENTRATION IN COAL BY COAL TYPE

| Coal type     | Cadmium concentration range, ppmwt | Cadmium concentration, ppmwt |                    |                   |
|---------------|------------------------------------|------------------------------|--------------------|-------------------|
|               |                                    | Mean                         | Standard deviation | Number of samples |
| Bituminous    | <0.02 to 100                       | 0.91                         | 7.3                | 3,527             |
| Subbituminous | 0.04 to 3.7                        | 0.38                         | 0.47               | 640               |
| Anthracite    | 0.1 to 0.3                         | 0.22                         | 0.30               | 52                |
| Lignite       | <0.11 to 5.5                       | 0.55                         | 0.61               | 183               |

Source: Reference 2.

TABLE 6-5. CADMIUM CONCENTRATION IN COAL BY REGION

| Region          | Number of samples | Cadmium concentration, ppmwt |                           |                    |
|-----------------|-------------------|------------------------------|---------------------------|--------------------|
|                 |                   | Range                        | Arithmetic mean           | Standard deviation |
| Appalachian     | 2,749<br>331      | ---<br>0.03-6.8              | 0.13 <sup>a</sup><br>0.7  | 0.21<br>---        |
| Interior        | 592<br>155        | ---<br><0.02-100             | 5.47 <sup>a</sup><br>7.1  | 18.5<br>---        |
| Illinois Basin  | 82                | 0.1-65                       | 2.89                      | ---                |
| Gulf Province   | 38<br>34          | ---<br><0.11-5.5             | 0.50 <sup>a</sup><br>1.3  | 0.49<br>---        |
| Northern Plains | 371<br>490        | ---<br>0.02-2.7              | 0.30 <sup>a</sup><br>0.08 | 0.48<br>---        |
| Rocky Mountains | 512<br>124        | ---<br><0.03-0.5             | 0.35 <sup>a</sup><br><0.5 | 0.38<br>---        |
| Alaska          | 107<br>18         | ---<br><0.1-0.7              | 0.28 <sup>a</sup><br><0.2 | 0.59<br>---        |

Source: Reference 2.

<sup>a</sup>Values are based on the most comprehensive data set currently available and may be used as typical values for cadmium in coal from these regions.

anthracite combustion are described briefly. References 5 and 8 offer additional details on these processes.

The two major coal combustion techniques used to fire bituminous and subbituminous coals are suspension firing and grate firing. Suspension firing is the primary combustion mechanism in pulverized coal and cyclone systems. Grate firing is the primary mechanism in underfeed and overfeed stokers. Both mechanisms are employed in spreader stokers.

Pulverized coal furnaces are used primarily in utility and large industrial boilers. In these systems, the coal is pulverized in a mill to the consistency of talcum powder (i.e., at least 70 percent of the particles will pass through a 200-mesh sieve). The pulverized coal is generally entrained in primary air and suspension-fired through the burners to the combustion chamber. Pulverized coal furnaces are classified as either dry or wet bottom, depending on the ash removal technique. Dry bottom furnaces fire coals with high ash fusion temperatures, and dry ash removal techniques are used. In wet bottom (slag tap) furnaces, coals with low ash fusion temperatures are used, and molten ash is drained from the bottom of the furnace.

Cyclone furnaces burn low ash fusion temperature coal crushed to a 4-mesh size. The coal is fed tangentially, with primary air, to a horizontal cylindrical combustion chamber. Small coal particles are burned in suspension, while the larger particles are forced against the outer wall. Because of the high temperatures developed in the relatively small furnace volume, and because of the low fusion temperature of the coal ash, much of the ash forms a liquid slag that is drained from the bottom of the furnace through a slag tap opening. Cyclone furnaces are used mostly in utility and large industrial applications.

In spreader stokers, a flipping mechanism throws the coal into the furnace and onto a moving fuel bed. Combustion occurs partially in suspension and partially on the grate. Because the entrained particles in the furnace exhaust have substantial carbon, flyash reinjection from mechanical collectors is commonly used to improve boiler efficiency. Ash residue in the fuel bed is deposited in a receiving pit at the end of the grate.

In overfeed stokers, coal is fed onto a traveling or vibrating grate and burns on the fuel bed as it progresses through the furnace. Ash particles fall into an ash pit at the rear of the stoker. "Overfeed" applies because the coal is fed onto the moving grate under an adjustable gate. Conversely, in "underfeed" stokers, coal is fed into the firing zone from underneath by mechanical rams or screw conveyers. The coal moves in a channel, known as a retort, from which it is forced upward, spilling over the top of each side to feed the fuel bed. Combustion is completed by the time the bed reaches the side dump grates, from which the ash is discharged to shallow pits.

The next most common coal used in the United States is lignite. Lignite is a relatively young coal with properties intermediate to those of bituminous coal and peat. Because lignite has a high moisture content (35 to 40 weight percent) and a low wet basis heating value (3,900 kcal/kg [7,200 Btu/lb]), it generally is used as a fuel only in areas in which it is mined. Lignite is used mainly for steam/electric production in power plants and typically is fired in larger pulverized coal-fired or cyclone-fired boilers.

Anthracite coal is a high-rank coal with more fixed carbon and less volatile matter than either bituminous coal or lignite. Because of its low volatile matter content and slight clinkering, anthracite is most commonly fired in medium-sized traveling grate



stokers and small hand-fired units. Some anthracite (occasionally with petroleum coke) is used in pulverized coal-fired boilers, and it may be blended with bituminous coal. Because of its low sulfur content (typically less than 0.8 weight percent) and minimal smoking tendencies, anthracite is considered a desirable fuel in areas where it is readily available. In the United States, anthracite is mined in northeastern Pennsylvania and is consumed mostly in Pennsylvania and surrounding States. The largest use of anthracite is for space heating. Lesser amounts are employed for steam/electric production, typically in underfeed stoker and pulverized coal dry-bottom boilers.

Although small quantities of cadmium may be emitted as fugitive particulate matter from coal storage and handling operations, the primary source of cadmium emissions from coal combustion is the combustion stack. Because the combustion zone in boilers operates at temperatures in excess of 1100°C (2000°F), the cadmium in the coal is volatilized. As the flue gas cools in the convective heat transfer section and further in the air preheater, the volatilized cadmium condenses. The cadmium may condense or adsorb onto existing particles according to the available surface area or it may condense homogeneously, forming fine particles. The cadmium thus volatilized would be depleted in the bottom ash and concentrated in the fly ash since the fly ash has more relative surface area than the bottom ash and since the bottom ash does not come in contact with the volatilized cadmium long enough for the cadmium to condense on the bottom ash.

#### Emission Control Measures<sup>6</sup>

Emission control measures for coal-fired boilers include controls based on combustor design and operating practices that are directed primarily at nitrogen oxides (NO<sub>x</sub>) and particulate

matter (PM) control and add-on air pollution control devices that are designed for acid gas and PM control. Those measures that are most likely to affect cadmium control are add-on PM and acid gas control devices. The primary types of PM control devices used for coal combustion include multiple cyclones, electrostatic precipitators, fabric filters (baghouses), and scrubbers, while both wet and dry flue gas desulfurization (FGD) systems are used for sulfur dioxide (SO<sub>2</sub>). Some measure of PM control is also obtained from ash settling in boiler/air heater/economizer dust hoppers, large breeches, and chimney bases, but these mechanisms will not significantly reduce cadmium emissions.

Electrostatic precipitators (ESP) are the most common high efficiency control device used on pulverized coal and cyclone units. These devices are also being used increasingly on stokers. Generally, PM collection efficiencies are a function of the specific collection area (i.e., the ratio of the collection plate area to the volumetric flow rate of flue gas through the device), and PM efficiencies of 99.9 weight percent have been measured with ESP's. Fabric filters have recently seen increased use in both utility and industrial applications both as a PM control measure and as the collection mechanism in dry FGD systems, generally effecting about 99.8 percent PM control efficiency. Scrubbers are also used to control PM emissions, although their primary use is to control emissions of sulfur oxides.

Mechanical collectors, generally multiple cyclones, are the primary means of control on many stokers and are sometimes installed upstream of high efficiency control devices in order to reduce the ash collection burden. Depending on application and design, multiple cyclone PM efficiencies can vary tremendously. However, these systems are relatively inefficient for fine particles and are not likely to provide measurable control of

cadmium emissions, which are primarily in the fine particle fractions of the exhaust.

Data on the performance of coal combustion emission control measures, relative to cadmium, are quite sparse. Furthermore, many of the data that are available are somewhat dated and are of questionable reliability. The section on emission factors below presents the available data on emission control system performance. However, in evaluating the potential emissions from a facility or group of facilities, any assumptions about control system performance, including those based on the data presented herein, should be examined carefully to assure that they are supported by reliable test data obtained via methods comparable to those described in Section 9. Also, performance estimates must be consistent with the physical and chemical properties of the compounds being emitted and with the operating characteristics of the systems being evaluated.

### Emissions

Two distinct sources of information were used to develop and evaluate cadmium emission factors for coal combustion. First, the data presented above on cadmium concentrations in coal and coal heating values were used to develop mass balance-based emission factors under the assumption that all cadmium charged with the coal is emitted as fine PM in the stack gas. Second, the emission factors presented in the coal and oil Locating and Estimating (L&E) document were reviewed and summarized.<sup>2</sup> No attempt was made to verify the sources of data used in the coal and oil L&E document or to rate the emission factors that were developed therein. The results obtained from each of the these methods are discussed separately in the paragraphs below. Then the relative merits of the emission factors obtained by the

different methods are examined, and the best typical emission factors are identified.

The information presented in the literature indicates that virtually all of the cadmium contained in the coal is emitted from the furnace as fine PM. Consequently, the coal heating values presented in Table 6-2 and the coal cadmium concentrations presented in Table 6-4 can be used to develop emission factors for major coal types under the assumption that all cadmium in the coal is emitted. Furthermore, note that the coal composition data in Table 6-2 are based on in-ground cadmium concentrations. The calculated emission factors shown in Table 6-6 are based on the assumption that as-fired coal contains equivalent concentrations. If cadmium concentrations are reduced during coal cleaning operations, these estimates will be biased high. Preliminary data from the United States Department of Energy indicates that there is some reduction in cadmium concentrations (25 to 50 percent) from coal cleaning.<sup>9</sup> The cadmium emission factors derived from these reduced cadmium concentrations are also shown in Table 6-6.

TABLE 6-6. CALCULATED UNCONTROLLED CADMIUM EMISSION FACTORS FOR COAL COMBUSTION

| Coal type                  | Calculated cadmium emission factors <sup>a</sup> |                         |
|----------------------------|--|-------------------------|
|                            | kg/10 <sup>15</sup> J                            | lb/10 <sup>12</sup> Btu |
| Bituminous <sup>b</sup>    | 30 (15-23)                                       | 70 (35-53)              |
| Subbituminous <sup>c</sup> | 17 (8.6-13)                                      | 40 (20-30)              |
| Anthracite <sup>d</sup>    | 7.3 (3.6-5.5)                                    | 17 (8.4-13)             |
| Lignite                    | 33 (17-25)                                       | 76 (38-57)              |

<sup>a</sup>Values in parentheses are based on a 25 to 50 percent reduction in cadmium concentrations from coal cleaning.

<sup>b</sup>Based on arithmetic average of the five average heating values in Table 6-2.

<sup>c</sup>Based on arithmetic average of the three average heating values in Table 6-2.

<sup>d</sup>Based on average heating value for coal category A2 in Table 6-2.

A comprehensive summary of the test data generated prior to 1989 for coal-fired boilers and furnaces was presented in Reference 2. The data from individual tests that were presented in that report are compiled in Table B-1 in Appendix B. Table 6-7 summarizes these data as a function of coal type and control status. Note the wide range of emission factors for each coal type. This range reflects the substantial variation in coal cadmium content and highlights the need to obtain coal-specific cadmium data to calculate emission estimates whenever possible. Also note that the data are combined across industry sector and boiler type because these parameters are not expected to have a substantial effect on emission factors.

As shown in Reference 2, the available test data on cadmium emission control are quite limited. Except for the ESP, control efficiencies are based on only a few data points and, therefore, may not be very reliable. According to Reference 2, approximately 75 percent control of cadmium emissions is achieved

TABLE 6-7. SUMMARY OF CADMIUM EMISSION FACTORS FOR COAL COMBUSTION

| Coal type <sup>a</sup> | Control status <sup>b</sup> | No. of boilers | No. of data points | Cadmium emission factors |           |                         |           |
|------------------------|-----------------------------|----------------|--------------------|--------------------------|-----------|-------------------------|-----------|
|                        |                             |                |                    | kg/10 <sup>15</sup> J    |           | lb/10 <sup>12</sup> Btu |           |
|                        |                             |                |                    | Average                  | Range     | Average                 | Range     |
| B                      | UN                          | 19             | 40                 | 34                       | 1.8-130   | 80                      | 4.1-300   |
| B                      | MP or MC                    | 11             | 20                 | 38                       | 0.082-210 | 88                      | 0.19-490  |
| B                      | ESP or MP/ESP               | 30             | 45                 | 2.5                      | 0.0040-23 | 5.8                     | 0.0090-53 |
| B                      | ESP-2 stage                 | 1              | 1                  | 19.8                     | --        | 46                      | --        |
| B                      | WS or MC/WS                 | 6              | 6                  | 42                       | 0.037-210 | 98                      | 0.086-490 |
| B                      | FF                          | 1              | 1                  | 0.14                     | --        | 0.33                    | --        |
| SB                     | UN                          | 3              | 5                  | 970                      | 2.1-1,900 | 2,200                   | 4.9-4,400 |
| SB                     | ESP or MP/ESP               | 4              | 5                  | 1.6                      | 0.17-6.0  | 3.7                     | 0.39-14   |
| SB                     | WS                          | 2              | 2                  | 110                      | 1.7-210   | 250                     | 4.0-490   |
| L                      | MC                          | 4              | 4                  | 5.3                      | 2.2-11    | 12                      | 5.1-26    |
| L                      | ESP                         | 3              | 3                  | 0.95                     | 0.52-1.5  | 2.2                     | 1.2-3.5   |
| L                      | ESP/WS                      | 1              | 2                  | 13                       | 0.77-25   | 31                      | 1.8-59    |
| A                      | UN                          | 3              | 3                  | 1.0                      | 0.60-1.5  | 2.4                     | 1.4-3.5   |

Source: Reference 2.

<sup>a</sup>B = bituminous, SB = subbituminous, L = lignite, A = anthracite.

<sup>b</sup>UN = uncontrolled, MP = mechanical precipitation system, MC = multiclone, ESP = electrostatic precipitator, WS = wet scrubber.

by ESP's. At least 75 percent control should be achieved by a combination of an ESP and a wet scrubber or by two ESP's in series. Insufficient data are available on the performance of wet scrubbers relative to cadmium emissions, but, according to the literature, wet scrubbers can achieve over 99 percent removal of PM. Cadmium reduction with a wet scrubber is expected to be less than that since cadmium partitions with the fine PM, and wet scrubbers are much less effective in reducing emissions of fine PM.<sup>10</sup> A conservative estimate of cadmium reduction with a wet scrubber would be 75 percent since PM control with a scrubber is at least as good as PM control with an ESP system. The reported 29 percent control achieved by multiclones is consistent with the inefficiency of these systems in reducing cadmium emissions.

Based on review of the available data, the best estimates for uncontrolled emission factors for typical coal combustion facilities are those obtained from a mass balance using coal composition data. This approach was selected because the available test data are of uncertain quality, and the coal concentration data are representative of a much larger industry segment. Controlled emission factors were obtained by applying 75 percent control for ESP's, greater than 75 percent control for a combination of ESP's and wet scrubbers, and greater than 75 percent control for two ESP's in series. Data were inadequate to estimate efficiencies for systems equipped with mechanical collectors, wet scrubbers, or fabric filters. The resultant best typical emission factors are shown in Table 6-8.

#### FUEL OIL COMBUSTION

As shown in Table 6-1, fuel oil use spans the four sectors of energy users. Distillate fuel oil is used extensively in all sectors with the largest use in the utility (31 percent) and the industrial (32 percent) sectors, but with substantial amounts

TABLE 6-8. BEST TYPICAL CADMIUM EMISSION FACTORS FOR COAL COMBUSTION

| Coal type <sup>a</sup> | Control status <sup>b</sup> | Cadmium emission factors |                         |
|------------------------|-----------------------------|--------------------------|-------------------------|
|                        |                             | kg/10 <sup>15</sup> J    | lb/10 <sup>12</sup> Btu |
| B                      | Uncontrolled                | 30                       | 70                      |
| B                      | ESP                         | 7.7                      | 18                      |
| B                      | ESP/wet scrubber            | <7.7                     | <18                     |
| B                      | ESP-2 stage                 | <7.7                     | <18                     |
|                        |                             |                          |                         |
| SB                     | Uncontrolled                | 17                       | 40                      |
| SB                     | ESP                         | 4.4                      | 10                      |
| SB                     | ESP/wet scrubber            | <4.4                     | <10                     |
| SB                     | ESP-2 stage                 | <4.4                     | <10                     |
|                        |                             |                          |                         |
| A                      | Uncontrolled                | 7.3                      | 17                      |
| A                      | ESP                         | 1.8                      | 4.3                     |
| A                      | ESP/wet scrubber            | <1.8                     | <4.3                    |
| A                      | ESP-2 stage                 | <1.8                     | <4.3                    |
|                        |                             |                          |                         |
| L                      | Uncontrolled                | 33                       | 76                      |
| L                      | ESP                         | 8.4                      | 19                      |
| L                      | ESP/wet scrubber            | <8.4                     | <19                     |
| L                      | ESP-2 stage                 | <8.4                     | <19                     |

<sup>a</sup>B = bituminous, SB = subbituminous, A = anthracite, L = lignite.

<sup>b</sup>ESP = electrostatic precipitator.



used in both the commercial (13 percent) and residential (23 percent) sectors. Residual oil is used primarily in the industrial (56 percent) and commercial (33 percent) sectors. Because the oil combustion process is not complex, and control systems are not widely applied to oil-fired units, the discussion below will focus on fuel oil characteristics and on emissions from oil-fired units.<sup>1</sup>

### Fuel Oil Characteristics<sup>2</sup>

The fuel oil characteristics of greatest importance for characterizing cadmium emissions from fuel oil combustion are the heating value and the cadmium content of the oil. The heating value is used for converting from emission factors with mass- or volume-based activity levels to those with activity levels based on heat input.

The term fuel oil covers a variety of petroleum products, including crude petroleum, lighter petroleum fractions such as kerosene, and heavier residual fractions left after distillation. To provide standardization and means for comparison, specifications have been established that separate fuel oils into various grades. Fuel oils are graded according to specific gravity and viscosity, with No. 1 Grade being the lightest and No. 6 the heaviest. The heating value of fuel oils is expressed in terms of kJ/L (Btu/gal) of oil at 16°C (60°F) or kJ/kg (Btu/lb) of oil at 16°C (60°F). The heating value per gallon increases with specific gravity because there is more weight per gallon. The heating value per mass of oil varies inversely with specific gravity because lighter oil contains more hydrogen. For an uncracked distillate or residual oil, heating value can be approximated by the following equation:

$$\text{Btu/lb} = 17,660 + (69 \times \text{API gravity})$$

For a cracked distillate, the relationship becomes:

$$\text{Btu/lb} = 17,780 + (54 \times \text{API gravity})$$

Table 6-9 provides an overall summary of the heating values of typical fuel oils used in the United States, and Table 6-10 shows the variability in fuel oil heating values used in various regions of the country. Appendix B of Reference 2 provides additional details.

The data base for cadmium content in fuel oils is much more limited than was the coal cadmium content data base. No single centralized data base is available, and the information presented below is based on limited data from individual studies.

Concentrations of cadmium in fuel oil depend upon the type of oil used. No comprehensive oil characterization studies have been done, but data in the literature report similar cadmium concentration means and ranges in residual and distillate oils. The suggested typical cadmium content of residual oil is 0.30 ppmwt, and that of distillate oil is 0.21 ppmwt. The typical value for cadmium in crude oil is 0.03 ppmwt. Table 6-11 lists the typical values for cadmium in oils. The typical values for distillate and crude oil were obtained by taking the average of the mean values found in the literature. The value for residual oil was based on reported concentrations without using the two high values of 2.27 and 2.02 ppmwt.

#### Process Description<sup>5,8</sup>

Fuel oils are broadly classified into two major types: distillate and residual. Distillate oils (fuel oil grade Nos. 1 and 2) are used mainly in domestic and small commercial applications in which easy fuel burning is required. Distillates are more volatile and less viscous than residual oils, having

TABLE 6-9. TYPICAL HEATING VALUES OF FUEL OILS

|                            | FUEL OIL GRADES                  |                                  |                                  |                                  |                                  |                                    |
|----------------------------|----------------------------------|----------------------------------|----------------------------------|----------------------------------|----------------------------------|------------------------------------|
|                            | No. 1                            | No. 2                            | No. 4                            | No. 5                            | No. 6                            | --                                 |
| Type                       | Distillate                       | Distillate                       | Very light residual              | Light residual                   | Residual                         | Crude <sup>b</sup>                 |
| Color                      | Light                            | Amber                            | Black                            | Black                            | Black                            | --                                 |
| Heating value <sup>a</sup> |                                  |                                  |                                  |                                  |                                  |                                    |
| kJ/L (Btu/gal)             | 38,200<br>(137,000)              | 40,900<br>(141,000)              | 40,700<br>(146,000)              | 41,200<br>(148,000)              | 41,800<br>(150,000)              | 39,900–42,200<br>(143,000–152,000) |
| kJ/kg (Btu/lb)             | 45,590–46,030<br>(19,670–19,860) | 44,430–45,770<br>(19,170–19,750) | 42,370–44,960<br>(18,280–19,400) | 41,950–44,080<br>(18,100–19,020) | 40,350–43,800<br>(17,410–18,900) | 40,700–43,200<br>(17,500–18,600)   |

Source: References 2 and 11.

6-24

<sup>a</sup>The distillate and residual oil samples analyzed for Btu/gal and Btu/lb heating values are different; therefore, the heating values presented do not directly correspond to one another.

<sup>b</sup>These crude oil values are based on a limited number of samples from West Coast field sites presented in Reference 11 and may not be representative of the distribution of crude oils processed in the United States.

TABLE 6-10. TYPICAL FUEL OIL HEATING VALUES FOR SPECIFIC REGIONS<sup>2</sup>

| Region         | No. 1 fuel oil                |                                    |                     | No. 2 fuel oil                |                                    |                     | No. 4 fuel oil                |                                    |                     |
|----------------|-------------------------------|------------------------------------|---------------------|-------------------------------|------------------------------------|---------------------|-------------------------------|------------------------------------|---------------------|
|                | Heating value, kJ/L (Btu/gal) |                                    |                     | Heating value, kJ/L (Btu/gal) |                                    |                     | Heating value, kJ/L (Btu/gal) |                                    |                     |
|                | No. of samples                | Range                              | Average             | No. of samples                | Range                              | Average             | No. of samples                | Range                              | Average             |
| Eastern        | 33                            | 36,900-37,800<br>(132,500-135,700) | 37,400<br>(134,200) | 56                            | 37,100-40,800<br>(133,100-146,600) | 38,800<br>(139,500) | 1                             | --<br>--                           | 40,700<br>(146,000) |
| Southern       | 13                            | 37,000-37,700<br>(132,900-135,400) | 37,400<br>(134,300) | 19                            | 38,000-39,400<br>(136,400-141,500) | 38,800<br>(139,400) | 0                             | --<br>--                           | --<br>--            |
| Central        | 27                            | 36,900-37,800<br>(132,500-135,700) | 37,300<br>(134,000) | 35                            | 37,800-40,800<br>(135,900-146,600) | 38,800<br>(139,200) | 2                             | 40,700-41,800<br>(146,000-150,100) | 41,200<br>(148,000) |
| Rocky Mountain | 14                            | 37,100-37,600<br>(133,100-135,100) | 37,400<br>(134,200) | 17                            | 37,900-39,100<br>(136,100-140,400) | 38,700<br>(139,000) | 2                             | 41,800-41,900<br>(150,100-150,500) | 41,900<br>(150,300) |
| Western        | 16                            | 36,700-37,900<br>(131,700-136,200) | 37,500<br>(134,600) | 18                            | 37,900-39,100<br>(136,100-140,500) | 38,700<br>(139,000) | 0                             | --<br>--                           | --<br>--            |

| Region         | No. 5 fuel oil                |                                    |                     | No. 6 fuel oil                |                                    |                     |
|----------------|-------------------------------|------------------------------------|---------------------|-------------------------------|------------------------------------|---------------------|
|                | Heating value, kJ/L (Btu/gal) |                                    |                     | Heating value, kJ/L (Btu/gal) |                                    |                     |
|                | No. of samples                | Range                              | Average             | No. of samples                | Range                              | Average             |
| Eastern        | 1                             | --<br>--                           | 41,300<br>(148,400) | 17                            | 40,800-43,900<br>(147,000-167,600) | 43,300<br>(161,900) |
| Southern       | 0                             | --<br>--                           | --<br>--            | 14                            | 41,900-43,600<br>(150,500-156,500) | 42,600<br>(152,900) |
| Central        | 4                             | 41,300-42,200<br>(148,400-151,500) | 41,700<br>(149,900) | 10                            | 41,900-44,200<br>(160,600-158,900) | 42,600<br>(152,900) |
| Rocky Mountain | 2                             | 42,900-43,600<br>(153,900-156,500) | 43,200<br>(155,200) | 7                             | 42,300-44,300<br>(161,900-159,200) | 43,000<br>(154,600) |
| Western        | 0                             | --<br>--                           | --<br>--            | 12                            | 41,700-45,500<br>(149,900-163,500) | 43,000<br>(154,400) |

Source: Reference 2.

negligible ash and nitrogen contents and usually containing less than 0.3 weight percent sulfur. Residual oils (grade Nos. 4, 5, and 6), on the other hand, are used mainly in utility,

TABLE 6-11. CADMIUM CONCENTRATION IN OIL BY OIL TYPE

| Fuel oil type    | Cadmium concentration, ppmwt |                    |
|------------------|------------------------------|--------------------|
|                  | Range                        | Typical value      |
| Residual No. 6   | 0.010-2.3                    | 0.30 <sup>a</sup>  |
| Distillate No. 2 | 0.010-0.95                   | 0.21 <sup>b</sup>  |
| Crude            | 0.010-0.05                   | 0.030 <sup>c</sup> |

Source: Reference 2.

<sup>a</sup>Based on reported concentrations without using the two high values, 2.3 and 2.0 ppmwt.

<sup>b</sup>Average of two studies.

<sup>c</sup>Average of three studies.

industrial and large commercial applications with sophisticated combustion equipment. No. 4 oil is sometimes classified as a distillate; No. 6 is sometimes referred to as Bunker C. Being more viscous and less volatile than distillate oils, the heavier residual oils (Nos. 5 and 6) must be heated to facilitate handling and proper atomization. Because residual oils are produced from the residue after lighter fractions (gasoline, kerosene, and distillate oils) have been removed from the crude oil, they contain significant quantities of ash, nitrogen, and sulfur.

Oil-fired boilers and furnaces are simpler and have much less variation in design than the coal-fired systems described earlier. The primary components of the system are the burner and the furnace. The burner atomizes the fuel and introduces it along with the combustion air into the unit via the flame. The

furnace provides the residence time and mixing needed to complete combustion of the fuel. The primary difference in systems that fire distillate oil and residual oil is that the residual oil systems must have an oil preheater to reduce the viscosity of the oil so that it can be atomized properly in the burner.

The only source of cadmium emissions from oil-fired boilers and furnaces is the combustion stack. Because the entire fuel supply is exposed to high flame temperatures, essentially all of the cadmium contained in the fuel oil will be volatilized, with most condensing onto small particles and then exhausted from the combustion chamber with the combustion gas exhaust. Unless the combustion gases are exposed to high-efficiency PM control systems, which typically are not found on oil-fired units, the cadmium will be exhausted as fine PM through the combustion stack.

#### Emission Control Measures<sup>8</sup>

The three types of control measures applied to oil-fired boilers and furnaces are boiler modifications, fuel substitution, and flue gas cleaning systems. Only fuel substitution and flue gas cleaning systems will affect cadmium emissions. Fuel substitution is used primarily to reduce SO<sub>2</sub> and NO<sub>x</sub> emissions. However, if the substituted fuels have lower cadmium concentrations, the substitution will also reduce cadmium emissions. Because PM emissions from oil-fired units are generally much lower than those from coal-fired units, high-efficiency PM control systems are generally not employed on oil-fired systems. Consequently, these flue gas cleaning systems are not likely to achieve substantial cadmium control. However, the flue gas systems that are typically used on oil-fired units are described briefly below.

Flue gas cleaning equipment generally is employed only on larger oil-fired boilers. Mechanical collectors, a prevalent type of control device, are primarily useful in controlling PM generated during soot blowing, during upset conditions, or when a very dirty heavy oil is fired. During these situations, high efficiency cyclonic collectors can affect up to 85 percent control of PM, but less control of cadmium is expected with mechanical collectors because cadmium is enriched onto fine PM, which is not as easily captured by control devices.

Electrostatic precipitators are commonly used in oil-fired power plants. Older ESP's may remove 40 to 60 percent of the PM, but lower cadmium control is expected because of the reason cited above. Scrubbing systems have been installed on oil-fired boilers to control both sulfur oxides and PM. These systems can achieve PM control efficiencies of 50 to 60 percent. Because they provide gas cooling below the condensation point of cadmium, some cadmium control may be obtained, but no data are available on their performance.

### Emissions

Three types of information were used to develop emission factors for oil combustion. First, the data described above on fuel oil heating value and cadmium content of fuel oils were used to develop emission factors by mass balance, assuming that all cadmium fired with the fuel oil is emitted through the stack. Second, the emission factors from the coal and oil L&E document were evaluated and summarized, but no attempt was made to verify original references or to rate these data. Finally, rated emission test data developed in preparation of this document were evaluated and summarized. The paragraphs below first present the results generated from each of the three sources. Then, the relative merits of the emission factors generated via each of the

procedures are discussed, and the best "typical" emission factors are identified.

The literature on fuel oil combustion suggests that essentially all cadmium in the fuel oil is volatilized in the combustion zone, with most condensing onto small particles and exhausted as fine PM in the combustion gas stream. Using the assumption that 100 percent of the cadmium in fuel oil leaves the boiler or furnace in the exhaust gases, the data in Tables 6-9 and 6-11 can be used to calculate uncontrolled emission factors for No. 2 distillate and No. 6 residual oil. Data presented in Reference 8, which show an average crude oil heating value of 42,500 kJ/kg (18,000 Btu/lb), can be combined with the cadmium content data in Table 6-11 to calculate an uncontrolled emission factor for crude oil combustion. The results of these calculations are presented in Table 6-12.

TABLE 6-12. CALCULATED UNCONTROLLED CADMIUM EMISSION FACTORS FOR FUEL OIL COMBUSTION

| Fuel oil type    | Cadmium emission factors |                         |
|------------------|--------------------------|-------------------------|
|                  | kg/10 <sup>15</sup> J    | lb/10 <sup>12</sup> Btu |
| Crude            | 0.71                     | 1.7                     |
| No. 6 Residual   | 7.1                      | 17                      |
| No. 2 Distillate | 4.7                      | 11                      |

A comprehensive summary of the emission data generated prior to 1989 was prepared by Brooks.<sup>2</sup> These results are tabulated in Table 6-13. The measured cadmium emission factors range from 0.021 kg/10<sup>15</sup>J (0.048 lb/10<sup>12</sup>Btu) to 91 kg/10<sup>15</sup>J (212 lb/10<sup>12</sup>Btu).



TABLE 6-13. MEASURED CADMIUM EMISSION FACTORS FOR FUEL OIL COMBUSTION

| Fuel oil type           | Industry sector <sup>a</sup> | Control status <sup>b</sup> | Fuel Cd content, ppmwt | Cadmium emission factors |                         | Date |
|-------------------------|------------------------------|-----------------------------|------------------------|--------------------------|-------------------------|------|
|                         |                              |                             |                        | kg/10 <sup>15</sup> J    | lb/10 <sup>12</sup> Btu |      |
| No. 6 oil               | I                            | MC/WS                       | 3.5                    | 21                       | 49 <sup>c</sup>         | 1979 |
| No. 6 oil               | I                            | MC                          | 3.5                    | 91                       | 210 <sup>d</sup>        | 1979 |
| No. 6 oil               | I                            | UN                          | 3.0                    | 0.30                     | 0.69                    | 1978 |
| No. 6 oil               | I                            | UN                          | 3.0                    | 1.3                      | 3.0                     | 1978 |
| No. 6 oil               | I                            | UN                          | 3.0                    | 3.7                      | 8.6                     | 1978 |
| 1:1 Residual/Crude      | U                            | UN                          | 0.70                   | 0.021                    | 0.048                   | 1981 |
| 1:1 Residual/Crude      | U                            | UN                          | 0.70                   | 3.5                      | 8.2                     | 1981 |
| 1:1 Residual/Crude      | U                            | UN                          | 0.50                   | 14                       | 33                      | 1981 |
| Distillate <sup>e</sup> | R                            | UN                          | ---                    | 11                       | 26 <sup>f</sup>         | 1979 |
| Distillate <sup>e</sup> | R                            | UN                          | 0.10                   | 2.1                      | 4.9                     | 1981 |
| Distillate <sup>e</sup> | R                            | UN                          | 0.10                   | 3.2                      | 7.5                     | 1981 |
| Distillate <sup>e</sup> | R                            | UN                          | 0.19                   | bd <sup>g</sup>          | bd <sup>g</sup>         | 1982 |

Source: Reference 2.

<sup>a</sup>U = utility, I = industrial, R = residential.

<sup>b</sup>MC = multiclone, WS = wet scrubber, UN = uncontrolled.

<sup>c</sup>Outlet from a wet scrubber.

<sup>d</sup>Inlet to a wet scrubber.

<sup>e</sup>Type of distillate oil not specified.

<sup>f</sup>Average of eight tests on seven units.

<sup>g</sup>bd = below detection limit.

The average distillate value is 5.4 kg/10<sup>15</sup>J (13 lb/10<sup>12</sup>Btu), similar to the calculated value of 4.7 kg/10<sup>15</sup>J (11 lb/10<sup>12</sup>Btu). The values for No. 6 residual oil from the 1979 study are higher than values reported in the other studies despite the presence of PM control devices. The causes of the large variation in measured cadmium emission factors are unknown.<sup>2</sup> Consequently, the test data in Table 6-13 should be used cautiously.

As a part of this study, three test reports prepared as a part of the California "Hot Spots" program were reviewed.<sup>11-13</sup> The emission factors generated from these three reports are summarized in Table 6-14. Each of the reports contained the data on fuel oil characteristics needed to calculate cadmium input rates, so Table 6-14 contains both calculated emission factors based on cadmium input levels and measured emission factors based on stack tests. Because cadmium levels in all of the fuel oils tested were below detection limits, all calculated emission factors are reported as "less than" values. Note that all three stack tests showed cadmium emission levels above the detection limit in the stack but substantially below the detection limit for cadmium in fuel oil. If cadmium levels in fuel oil are close to the detection limit, then the tests showed measured emissions to be substantially less than cadmium input to the process. On balance, these data provide little information for emission factor development.

TABLE 6-14. CADMIUM EMISSION FACTORS FOR FUEL OIL COMBUSTION  
GENERATED FROM CALIFORNIA "HOT SPOTS" TESTS

| Process type                | Fuel oil type | Calculated cadmium emission factors <sup>a</sup> |                         | Measured cadmium emission factors <sup>a</sup> |                         |
|-----------------------------|---------------|--|-------------------------|--|-------------------------|
|                             |               | kg/10 <sup>15</sup> J                            | lb/10 <sup>12</sup> Btu | kg/10 <sup>15</sup> J                          | lb/10 <sup>12</sup> Btu |
| Pipeline/<br>process heater | Crude         | <12  | <27                     | 2.5  | 5.8                     |
| Generator                   | Crude         | <7.3   | <17                     | 0.54   | 1.3                     |
| Power boiler                | Residual      | <4.7   | <11                     | 0.31   | 0.72                    |

Source: References 11 through 13.

<sup>a</sup>Based on assumed crude oil heating value of 42,500 kJ/kg (18,300 Btu/lb) and an assumed residual oil heating value of 43,600 kJ/kg (18,800 Btu/lb).

Given the limited emission test data available and the concerns about possible biases in those data, the mass balance approach was used to estimate the best "typical" emission factor for distillate and residual fuel oil combustion.

The available information on uncontrolled cadmium emissions from crude oil combustion is ambiguous. The limited test data presented in Tables 6-13 and 6-14 show measured emission factors that range from 0.02 to 14 kg/10<sup>15</sup> J (0.05 to 33 lb/10<sup>12</sup> Btu), a range of almost three orders of magnitude. Because these data are quite sparse and the relative quality of the data is uncertain, the midpoint of the range was selected as the best "typical" emission factor.

The uncontrolled emission factors for distillate, residual, and crude oil are presented in Table 6-15. Data are insufficient to develop controlled emission factors for fuel oil combustion.

TABLE 6-15. BEST TYPICAL CADMIUM EMISSION FACTORS FOR FUEL OIL COMBUSTION

| Fuel oil type    | Cadmium emission factors |                         |
|------------------|--------------------------|-------------------------|
|                  | kg/10 <sup>15</sup> J    | lb/10 <sup>12</sup> Btu |
| Crude            | 7.0                      | 16                      |
| No. 6 Residual   | 7.1                      | 17                      |
| No. 2 Distillate | 4.7                      | 11                      |

NATURAL GAS COMBUSTION

Natural gas is one of the major fuels used throughout the country. As shown in Table 6-1, natural gas is used as an energy source in all four sectors, but the greatest uses are in the industrial (46 percent) and residential (15 percent) sectors. Natural gas is used as an energy source throughout the country. The five States that consume the largest quantities of natural gas are Texas, California, Louisiana, Illinois, and New York. However, only Louisiana and Oklahoma consume more energy via natural gas combustion than by either coal or petroleum products combustion.<sup>1</sup>

Natural Gas Characteristics<sup>8,14</sup>

Natural gas is considered to be a clean fuel. It consists of primarily methane (generally 80 percent or greater by mass), along with varying amounts of ethane, propane, butane, and inert material (typically nitrogen, carbon dioxide, and helium). The average heating value of natural gas is about 8,900 kilocalories per standard cubic meter (kcal/scm) (1,000 British thermal units per standard cubic foot [Btu/scf]), with levels ranging from 8,000 to 9,000 kcal/scm (900 to 1,100 Btu/scf). No data are available on the cadmium content of natural gas. However, concentrations are expected to be quite low. Little cadmium is

expected to be found in raw gas, and the processing steps used to recover liquid constituents and to remove hydrogen sulfide from the raw gas should also remove any cadmium that is contained in the raw gas.

#### Process Description<sup>14</sup>

Natural gas combustion sources can be divided into four categories: utility/large industrial boilers, small industry boilers, commercial boilers, and residential furnaces. These systems are configured differently, but the combustion processes are comparable for all categories. The natural gas and combustion air are mixed in a burner and introduced to a combustion chamber via a flame. The natural gas flame temperature, which exceeds 1000°C (1800°F), will volatilize any cadmium in the fuel. Most of the cadmium will then condense onto small particles and be exhausted as fine PM from the boiler or furnace with the combustion gas stream. This exhaust stream is the only source of cadmium emissions from natural gas combustion.

#### Emission Control Measures

No control measures apply to natural gas-fired boilers, and furnaces are expected to affect cadmium emissions.

#### Emissions

No data are available on cadmium emissions from natural gas combustion, but emissions are expected to be quite low. As stated earlier, little cadmium is expected to be found in raw gas, and, given the processing steps that natural gas undergoes, any cadmium that is present would be removed from the raw gas. Consequently, no cadmium emission factor is presented for natural gas combustion.

## WOOD COMBUSTION

Wood and wood wastes are used as fuel in both the industrial and residential sectors. In the industrial sector, wood waste is fired to industrial boilers to provide process heat, while wood is fired to fireplaces and wood stoves in the residential sectors. No data are available on the cadmium content of wood and wood wastes. Consequently, the information below includes process descriptions for the three combustion processes (boilers, fireplaces, and wood stoves), descriptions of the control measures used for wood-fired processes, and emission factors.

### Process Description<sup>14</sup>

Wood waste combustion in boilers is mostly confined to those industries for which it is available as a byproduct. These boilers generate energy and alleviate possible solid waste disposal problems. In boilers, wood waste is normally burned in the form of hogged wood, sawdust, shavings, chips, sanderdust, or wood trim. Heating values for this waste range from about 2,200 to 2,700 kcal/kg (4,000 to 5,000 Btu/lb) of fuel on a wet, as-fired basis. The moisture content is typically near 50 weight percent but may vary from 5 to 75 weight percent, depending on the waste type and storage operations. Generally, bark is the major type of waste burned in pulp mills; either a mixture of wood and bark waste or wood waste alone is burned most frequently in the lumber, furniture, and plywood industries. As of 1980, approximately 1,600 wood-fired boilers were operating in the United States, with a total capacity of over 30 gigawatts(GW) ( $1.0 \times 10^{11}$  Btu/hr). No specific data on the distribution of these boilers were identified, but most are likely to be located in the Southeast, the Pacific Northwest States, Wisconsin, Michigan, and Maine.

The most common firing method employed for larger wood-fired boilers is the spreader stoker. Wood enters the furnace through a fuel chute and is spread either pneumatically or mechanically across the furnace, where small pieces of the fuel burn while in suspension. Simultaneously, larger pieces of fuel are spread in a thin, even bed on a stationary or moving grate. Natural gas or oil is often fired in spreader stoker boilers as auxiliary fuel to maintain a constant steam supply when the wood waste supply fluctuates. Auxiliary fuel can also provide more steam than can be generated from the waste supply alone.

Another boiler type sometimes used for wood combustion is the suspension-firing boiler. This boiler differs from a spreader stoker in that small-sized fuel (normally less than 2 mm) is blown into the boiler and combusted by suspension firing in air rather than on fixed grates. Rapid changes in combustion rate and, therefore, steam generation rate are possible because the finely divided fuel particles burn very quickly.

Wood stoves are commonly used in residences as space heaters, both as the primary source of residential heat and to supplement conventional heating systems. The three different categories of wood stoves are:

- The conventional wood stove;
- The noncatalytic wood stove; and
- The catalytic wood stove.

The conventional stove category comprises all stoves without catalytic combustors not included in the other noncatalytic categories (i.e., noncatalytic and pellet). Conventional stoves do not have any emissions reduction technology or design features and, in most cases, were manufactured before July 1, 1986.

Stoves of many different airflow designs may be in this category, such as updraft, downdraft, crossdraft, and S-flow.

Noncatalytic wood stoves are those units that do not employ catalysts but do have emissions reduction technology or features. Typical noncatalytic design includes baffles and secondary combustion chambers.

Catalytic stoves are equipped with a ceramic or metal honeycomb device (called a combustor or converter) that is coated with a noble metal such as platinum or palladium. The catalyst material reduces the ignition temperature of the unburned volatile organic compounds (VOC's) and carbon monoxide (CO) in the exhaust gases, thus augmenting their ignition and combustion at normal stove operating temperatures.

Fireplaces are used primarily for aesthetic effects and secondarily as a supplemental heating source in houses and other dwellings. Wood is the most common fuel for fireplaces, but coal and densified wood "logs" may also be burned. The user intermittently adds fuel to the fire by hand.

All of the systems described above operate at temperatures that are above the boiling point of cadmium. Consequently, any cadmium contained in the fuel will be emitted with the combustion gases as enriched fine PM. The combustion exhaust stack is the only source of cadmium emissions from these processes.

#### Emission Control Measures<sup>14</sup>

Although some wood stoves use control measures to reduce VOC and CO emissions, these techniques are not expected to affect cadmium emissions. However, wood waste boilers do employ PM



control equipment, which may provide some reduction. These systems are described briefly below.

Currently, the four most common control devices used to reduce PM emissions from wood-fired boilers are mechanical collectors, wet scrubbers, ESP's, and fabric filters. Of these controls, only the last three have the potential for significant cadmium reduction.

The most widely used wet scrubbers for wood-fired boilers are venturi scrubbers. With gas-side pressure drops exceeding 4 kilopascals (15 inches of water), PM collection efficiencies of 90 percent or greater have been reported for venturi scrubbers operating on wood-fired boilers. No data were located on the performance of these systems relative to cadmium emissions, but it is expected to be somewhat less because cadmium is likely to be concentrated in the fine PM, which is less readily collected by control devices.

Fabric filters (i.e., baghouses) and ESP's are employed when PM collection efficiencies above 95 percent are required. Collection efficiencies of 93 to 99.8 percent for PM have been observed for ESP's operating on wood-fired boilers, but cadmium efficiencies are likely to be somewhat less because of the reason cited above. Fabric filters have had limited applications to wood-fired boilers because of fire hazards. Despite complications, fabric filters are generally preferred for boilers firing salt-laden wood. This fuel produces fine PM with a high salt content for which fabric filters can achieve high collection efficiencies. In two tests of fabric filters operating on salt-laden wood-fired boilers, PM collection efficiencies were above 98 percent. No data are available on cadmium emission reduction for fabric filters, but because cadmium is enriched

onto fine PM, which is less readily collected than PM as a whole, it is expected that efficiencies will be somewhat lower.

### Emissions

The data on cadmium emissions from wood combustion are quite limited. A recent study to update the wood waste combustion section of AP-42 provided a range and average typical emission factor for wood waste combustion in boilers based on the results of seven tests. Table 6-16 presents the range and average obtained from those tests and the range and average from a California "Hot Spots" test of a fluidized-bed wood-fired boiler not included in the AP-42 update.<sup>15,16</sup>

TABLE 6-16. SUMMARY OF CADMIUM EMISSION FACTORS FOR WOOD COMBUSTION

| Operation                                  | Cadmium emission factors           |         |                                     |         |
|--|------------------------------------|---------|-------------------------------------|---------|
|  | 10 <sup>-5</sup> kg/Mg wood burned |         | 10 <sup>-5</sup> lb/ton wood burned |         |
|  | Range                              | Average | Range                               | Average |
| Wood waste boiler <sup>a</sup>             | 0.13-27                            | 0.85    | 0.27-54                             | 1.7     |
| Wood waste boiler-"Hot Spots" <sup>b</sup> | 0.44-1.0                           | 0.74    | 0.88-2.0                            | 1.5     |
| Residential wood stove-conventional        | --                                 | 1.1     | --                                  | 2.2     |
|  | --                                 | 3.6     | --                                  | 7.2     |
| Residential wood stove-noncatalytic        | --                                 | 1.0     | --                                  | 2.0     |
| Residential wood stove-catalytic           | --                                 | 2.3     | --                                  | 4.6     |

Source: References 15 through 17.

<sup>a</sup>Based on an assumed heating value of 10,460 kJ/kg (4,500 Btu/lb) and PM control.

<sup>b</sup>Based on a heating value of 19,220 kJ/kg (8,270 Btu/lb) and PM control with multiclones and ESP.

A review of the literature produced four emission factors for residential wood stove combustion, which are also presented in Table 6.16.<sup>15,17</sup> Three of the four emission factors were

provided by the section on residential wood combustion in the recent AP-42 and included emission factors for conventional, noncatalytic, and catalytic wood stove combustion. However, the data used to develop these emission factors showed a high degree of variability within the source population. The fourth emission factor from the literature was based on only a single test at one location of an uncontrolled conventional wood stove and may not be representative of conditions across the United States. Therefore, these emission factors should be used cautiously.

#### MUNICIPAL WASTE COMBUSTION

Refuse or municipal solid waste (MSW) consists primarily of household garbage and other nonhazardous commercial, institutional, and industrial solid waste. Municipal waste combustors (MWC's) are used to reduce the mass and volume of MSW that ultimately must be landfilled.

Currently, over 160 MWC plants are in operation in the United States with capacities greater than 36 megagrams per day (Mg/d) (40 tons per day [ton/d]) and a total capacity of approximately 100,000 Mg/d (110,000 ton/d) of MSW. It is predicted that by 1997, the total MWC capacity will approach 150,000 Mg/d (165,000 ton/d), which represents over 28 percent of the estimated total amount of MSW generated in the United States by the year 2000. Table 6-17 shows the geographic distribution of MWC units and capacities by States.<sup>18</sup>

In addition to these large units, a number of smaller, specialized facilities around the United States also burn MSW. However, the total nationwide capacity of those smaller units is only a small fraction of the total capacity of the units with individual capacities of 36 Mg/d (40 ton/d) and larger.

TABLE 6-17. SUMMARY OF GEOGRAPHICAL DISTRIBUTION OF MWC FACILITIES

| State | Number of MWC facilities | State MWC capacity<br>Mg/d (ton/d) | Percentage of total<br>MWC capacity in the<br>United States |
|-------|--------------------------|------------------------------------|---|
| AK    | 2                        | 150(170)                           | <1  |
| AL    | 2                        | 900(990)                           | 1   |
| AR    | 5                        | 350(380)                           | <1  |
| CA    | 3                        | 2,330(2,560)                       | 2   |
| CT    | 9                        | 6,050(6,660)                       | 6   |
| DC    | 1                        | 910(1,000)                         | 1   |
| DE    | 1                        | 550(600)                           | <1  |
| FL    | 14                       | 15,770(17,350)                     | 16  |
| GA    | 1                        | 450(500)                           | <1  |
| HI    | 1                        | 2,510(2,760)                       | 2   |
| IA    | 1                        | 180(200)                           | <1  |
| ID    | 1                        | 45(50)                             | <1  |
| IL    | 1                        | 1,450(1,600)                       | 1   |
| IN    | 1                        | 2,150(2,360)                       | 2   |
| MA    | 10                       | 9,400(10,340)                      | 9   |
| MD    | 3                        | 3,460(3,810)                       | 3   |
| ME    | 4                        | 1,700(1,870)                       | 2   |
| MI    | 5                        | 4,380(4,820)                       | 4   |
| MN    | 13                       | 4,850(5,330)                       | 5   |
| MO    | 1                        | 71(78)                             | <1  |
| MS    | 1                        | 140(150)                           | <1  |
| MT    | 1                        | 65(72)                             | <1  |
| NC    | 4                        | 710(780)                           | 1   |
| NH    | 4                        | 780(860)                           | 1   |
| NJ    | 6                        | 5,290(5,820)                       | 5   |
| NY    | 15                       | 11,370(12,510)                     | 11  |
| OH    | 4                        | 4,360(4,800)                       | 4   |
| OK    | 2                        | 1,120(1,230)                       | 1   |
| OR    | 3                        | 740(810)                           | 1   |
| PA    | 6                        | 6,550(7,200)                       | 6   |
| PR    | 1                        | 950(1,040)                         | 1   |
| SC    | 2                        | 760(840)                           | 1   |
| TN    | 4                        | 1,350(1,480)                       | 1   |
| TX    | 4                        | 220(240)                           | <1  |
| UT    | 1                        | 360(400)                           | <1  |
| VA    | 9                        | 6,220(6,840)                       | 6   |
| WA    | 5                        | 1,360(1,500)                       | 1   |
| WI    | 9                        | 1,240(1,360)                       | 1   |
| TOTAL | 160                      | 101,200 (111,400)                  | 100   |

Source: Reference 18.

## Municipal Solid Waste Characteristics<sup>19</sup>

Municipal solid waste is a heterogeneous mixture of the various materials found in household, commercial, and industrial wastes. Major constituents in typical municipal waste are listed in Table 6-18. No data on the concentration of cadmium in MSW streams were located, but known sources of cadmium in MSW are batteries, discarded electrical equipment and wiring, and plastics.

## Process Description<sup>8,18,20,21</sup>

The three principal MWC classes are mass burn, refuse-derived fuel (RDF), and modular combustors. The paragraphs below briefly describe some of the key design and operating characteristics of these different combustor types. References 8, 18, and 20 provide more detailed process descriptions and process diagrams for each of the systems described below.

In mass burn units, the MSW is combusted without any preprocessing other than removal of items too large to go through the feed system. In a typical mass burn combustor, refuse is placed on a grate that moves through the combustor. Combustion air in excess of stoichiometric amounts is supplied both below (underfire air) and above (overfire air) the grate. Mass burn combustors are usually erected at the site (as opposed to being prefabricated at another location) and range in size from 46 to 900 Mg/d (50 to 1,000 tons/d) of MSW throughput per unit. The mass burn combustor category can be divided into mass burn refractory wall (MB/REF), mass burn/waterwall (MB/WW), and mass burn/rotary waterwall (MB/RC) designs. The two most common, MB/REF and MB/WW, are described below.

TABLE 6-18. CURRENT AND FORECAST COMPOSITION OF DISPOSED RESIDENTIAL AND COMMERCIAL WASTE (WEIGHT PERCENT)

| Component            | Year       |            |
|----------------------|------------|------------|
|                      | 1980       | 1990       |
| Paper and Paperboard | 33.6       | 38.3       |
| Yard Wastes          | 18.2       | 17.0       |
| Food Wastes          | 9.2        | 7.7        |
| Glass                | 11.3       | 8.8        |
| Metals               | 10.3       | 9.4        |
| Plastics             | 6.0        | 8.3        |
| Wood                 | 3.9        | 3.7        |
| Textiles             | 2.3        | 2.2        |
| Rubber and Leather   | 3.3        | 2.5        |
| Miscellaneous        | <u>1.9</u> | <u>2.1</u> |
| TOTAL                | 100.0      | 100.0      |

Source: Reference 19.

The MB/REF combustors are older facilities that comprise several designs. One design involves a batch-fed upright combustor, which may be cylindrical or rectangular in shape. A second design consists of rectangular combustion chambers with traveling, rocking, or reciprocating grates. This type of combustor is continuously fed and operates in an excess air mode with both underfire and overfire air provided. The waste is moved on a traveling grate and is not mixed as it advances through the combustor. As a result, waste burnout or complete combustion is inhibited by fuel bed thickness, and there is considerable potential for unburned waste to be discharged into the bottom ash pit. Rocking and reciprocating grate systems mix and aerate the waste bed as it advances through the combustion chamber, thereby improving contact between the waste and combustion air and increasing the burnout of combustibles. The system generally discharges the ash at the end of the grates to a water quench pit for collection and disposal in a landfill. The MB/REF combustors typically operate at relatively high excess air rates to prevent excessive temperatures, which can result in refractory damage, slagging, fouling, and corrosion problems. One adverse effect of higher excess air levels is the potential for increased carryover of PM from the combustion chamber, and, ultimately, increased stack emission rates.

Because of their operating characteristics, the traveling grate systems may have cool ash pockets in which cadmium is not exposed to high temperatures and is thereby retained in the ash, rather than being exhausted with the combustion gas stream. Consequently, cadmium may be emitted as fugitive emissions from ash handling. However, the combustion stack is the primary source of cadmium emissions. In the rocking and reciprocating grate systems, essentially all cadmium will be exhausted with the combustion gas.

The MB/WW design represents the predominant technology in the existing population of large MWC's, and it is expected that over 50 percent of new units will be MB/WW designs. In MB/WW units, the combustor walls are constructed of metal tubes that contain pressurized water and recover radiant energy from the combustion chamber. With this type of system, unprocessed waste (after removal of large, bulky items and noncombustibles) is delivered by an overhead crane to a feed hopper that conveys the waste into the combustion chamber. Nearly all modern MB/WW facilities utilize reciprocating grates or roller grates to move the waste through the combustion chamber. The grates typically include two or three separate sections where designated stages in the combustion process occur. On the initial grate section, referred to as the drying grate, the moisture content of the waste is reduced prior to ignition. In the second grate section, the burning grate, the majority of active burning takes place. The third grate section, referred to as the burnout or finishing grate, is where remaining combustibles in the waste are burned. Bottom ash is discharged from the finishing grate into a water-filled ash quench pit or ram discharger. From there, the moist ash is discharged to a conveyor system and transported to an ash loading area or storage area prior to disposal. Because the waste bed is exposed to fairly uniform high combustion temperatures, cadmium will volatilize and condense on small particles. Most cadmium will be exhausted as fine PM with the combustion gases, although some may be partitioned with the ash.

Refuse-derived fuel combustors burn MSW that has been processed to varying degrees, from simple removal of bulky and noncombustible items accompanied by shredding, to extensive processing to produce a finely divided fuel suitable for co-firing in pulverized coal-fire boilers. Processing MSW to RDF generally raises the heating value of the waste because many of the noncombustible items have been removed.



A set of standards for classifying RDF types has been established by the American Society for Testing and Materials. The type of RDF used is dependent on the boiler design. Boilers that are designed to burn RDF as the primary fuel usually utilize spreader stokers and fire fluff RDF in a semi-suspension mode. This mode of feeding is accomplished by using an air swept distributor, which allows a portion of the feed to burn in suspension and the remainder to be burned out after falling on a horizontal traveling grate. The number of RDF distributors in a single unit varies directly with unit capacity. The distributors are normally adjustable so that the trajectory of the waste feed can be varied. Because the traveling grate moves from the rear to the front of the furnace, distributor settings are adjusted so that most of the waste lands on the rear two-thirds of the grate to allow more time for combustion to be completed on the grate. Bottom ash drops into a water-filled quench chamber. Underfire air is normally preheated and introduced beneath the grate by a single plenum. Overfire air is injected through rows of high pressure nozzles, providing a zone for mixing and completion of the combustion process. Because essentially all of the waste is exposed to high combustion temperatures on the grate, most of the cadmium in the RDF will be discharged with the combustion gas exhaust as fine PM.

In a fluidized-bed combustor (FBC), fluff or pelletized RDF is combusted on a turbulent bed of noncombustible material, such as limestone, sand, or silica. In its simplest form, the FBC consists of a combustor vessel equipped with a gas distribution plate and underfire air windbox at the bottom. The combustion bed overlies the gas distribution plate. The RDF may be injected into or above the bed through ports in the combustor wall. The combustor bed is suspended or "fluidized" through the introduction of underfire air at a high flow rate. Overfire air is used to complete the combustion process.

Good mixing is inherent in the FBC design. Fluidized-bed combustors have uniform gas temperatures and mass compositions in both the bed and in the upper region of the combustor. This uniformity allows the FBC's to operate at lower excess air and temperature levels than conventional combustion systems. Waste-fired FBC's typically operate at excess air levels between 30 and 100 percent and at bed temperatures around 815°C (1500°F). At this temperature, most of the cadmium will be volatilized. The cadmium then condenses onto small particles and is exhausted with the combustion gas stream as fine PM.

In terms of number of facilities, modular starved- (or controlled-) air (MOD/SA) combustors represent a large segment of the existing MWC population. However, because of their small sizes, they account for only a small percentage of the total capacity. The basic design of a MOD/SA combustor consists of two separate combustion chambers, referred to as the "primary" and "secondary" chambers. Waste is batch-fed intermittently to the primary chamber by a hydraulically activated ram. The charging bin is filled by a front-end loader or by other mechanical systems. Waste is fed automatically on a set frequency, with generally 6 to 10 minutes between charges.

Waste is moved through the primary combustion chamber by either hydraulic transfer rams or reciprocating grates. Combustors using transfer rams have individual hearths upon which combustion takes place. Grate systems generally include two separate grate sections. In either case, waste retention times in the primary chamber are lengthy, lasting up to 12 hours. Bottom ash is usually discharged to a wet quench pit.

The quantity of air introduced in the primary chamber defines the rate at which waste burns. Combustion air is introduced in the primary chamber at substoichiometric levels,

resulting in a flue gas rich in unburned hydrocarbons. The combustion air flow rate to the primary chamber is controlled to maintain an exhaust gas temperature set point [generally 650° to 980°C (1200° to 1800°F)], which corresponds to about 40 to 60 percent theoretical air. As the hot, fuel-rich flue gases flow to the secondary chamber, they are mixed with excess air to complete the burning process. The temperature of the exhaust gases from the primary chamber is above the autoignition point. Thus, completing combustion is simply a matter of introducing air to the fuel-rich gases. The amount of air added to the secondary chamber is controlled to maintain a desired flue gas exit temperature, typically 980° to 1200°C (1800° to 2200°F). At these primary chamber and secondary chamber temperatures, essentially all of the cadmium contained in the waste is expected to be volatilized, condense onto small particles, and be emitted as fine PM from the secondary chamber with the combustion gas stream.<sup>21</sup>

#### Emission Control Measures<sup>18</sup>

Cadmium emissions from MWC units are generally controlled by condensing the cadmium vapors from the combustion chamber to particle form and then removing the particle-phase cadmium with a high-efficiency PM control device. The PM control devices most frequently used in the United States are ESP's and fabric filters. Typically, newer MWC systems use a combination of gas cooling and duct sorbent injection (DSI) or spray dryer (SD) systems upstream of the PM device to reduce temperatures and provide a mechanism for acid gas control. The paragraphs below briefly describe the DSI and SD processes. Because the ESP's and FF's used on MWC's are comparable to those used on other combustion systems, they are not described. Reference 18 provides more detailed descriptions of the control systems and additional information on the performance of these systems.

Spray drying in combination with either fabric filtration or an ESP is the most frequently used acid gas control technology for MWC's in the United States. Spray dryer/fabric filter systems are more common than SD/ESP systems and are used most on new, large MWC's. In the spray drying process, lime is slurried and then injected into the SD through either a rotary atomizer or dual-fluid nozzles. The key design and operating parameters that significantly affect SD performance are the SD's outlet approach to saturation temperature and lime-to-acid gas stoichiometric ratio. The SD outlet approach to saturation temperature is controlled by the amount of water in the lime slurry. More effective acid gas and metals removal occurs at lower temperatures, but the gas temperature must be kept high enough to ensure the slurry and reaction products are adequately dried prior to collection in the PM control device.

With DSI, powdered sorbent is pneumatically injected into either a separate reaction vessel or a section of flue gas duct located downstream of the combustor economizer. Alkali in the sorbent (generally calcium) reacts with HCl and SO<sub>2</sub> to form alkali salts (e.g., calcium chloride [CaCl<sub>2</sub>] and calcium sulfite [CaSO<sub>3</sub>]). Reaction products, fly ash, and unreacted sorbent are collected with either an ESP or fabric filter.

Based on a summary of MWC cadmium emission data in Reference 18, substantial cadmium removal can be achieved using spray drying or duct sorbent injection in combination with fabric filtration or an ESP. A cadmium removal efficiency of 98 percent can be achieved with an SD/ESP system, slightly lower than the cadmium control with an SD/FF system (99 percent) because of the metals enrichment of the fine particles. If the removal efficiency of PM with an ESP is 98 percent or greater, the removal efficiency of cadmium with an ESP will generally be at least 95 percent. Removal efficiencies greater than 95 percent

can generally be achieved by DSI/ESP systems. A DSI/FF system can achieve 99 percent removal of cadmium.

### Emissions<sup>18</sup>

A recent study conducted to update the municipal waste combustion section of AP-42 provided a comprehensive review of the available MWC cadmium emission data, which are summarized in Table B-2 of Appendix B. The emission data that are presented in Appendix B are in concentration units rather than emission factors because the study found that most of the test reports contained insufficient process data to generate emission factors.

After reviewing the test data, the authors concluded that the development of emission factors for MWC's, using only the test reports which estimated feed rates, would eliminate data from so many facilities, especially key facilities, that the values derived were not likely to be representative of the entire MWC population. In addition, the subjective nature of the refuse feed rates called into question the validity of the limited data. Consequently, emission factors were developed using the F-factor, which is the ratio of the gas volume of the products of combustion to the heating value of the fuel developed by the EPA (EPA Method 19). This approach requires an F-factor and an estimate of the fuel heating value. For MWC's, an F-factor of 0.257 dscm/MJ (9,570 dscf/10<sup>6</sup> Btu) (at zero percent oxygen) is assigned. For all combustor types, except RDF combustors, an assumed heating value of 10,500 kJ/kg (4,500 Btu/lb) refuse was also used. For RDF combustor units, the processed refuse has a higher heating value, and the assumed heating value was 12,800 kJ/kg (5,500 Btu/lb). Overall, these data are representative of average values for MWC's.

The resultant best typical emission factors for different combinations of combustor and control device are presented in Table 6-19. While this procedure does provide good average emission factors that represent an industry cross section, it should not be used to convert individual data points in Appendix B. The assumed F-factor and waste heating values above may not be appropriate for specific facilities.

#### SEWAGE SLUDGE INCINERATORS

Currently, about 200 sewage sludge incinerators (SSI's) operate in the United States using one of three technologies: multiple hearth, fluidized-bed, and electric infrared. Multiple hearth units predominate, with over 80 percent of the identified, operating SSI's being of that type. About 15 percent of the SSI's are fluidized-bed combustors; 3 percent are electric infrared; and the remainder cofire sewage sludge with municipal solid waste.<sup>22</sup>

Figure 6-1 shows the distribution of sewage sludge incinerators in the United States<sup>23</sup> Most facilities are located in the Eastern United States, but a substantial number are also located on the West Coast. New York has the largest number of SSI facilities with 33, followed by Pennsylvania and Michigan with 21 and 19, respectively. About  $1.5 \times 10^6$  Mg ( $1.6 \times 10^6$  tons) of sewage sludge on a dry basis are estimated to be incinerated annually.<sup>22</sup>

No data have been located on the cadmium content of sewage sludge.

The sections below provide SSI process descriptions, a discussion of control measures, and a summary of cadmium emission factors.

TABLE 6-19. BEST TYPICAL CADMIUM EMISSION FACTORS FOR MUNICIPAL WASTE COMBUSTORS

| Combustor type             | Control status <sup>a</sup> | Cadmium emission factors |                               |
|----------------------------|-----------------------------|--------------------------|-------------------------------|
|                            |                             | g/Mg waste               | 10 <sup>-3</sup> lb/ton waste |
| Mass Burn/Waterwall        | UN                          | 4.8                      | 9.7                           |
|                            | SD/FF                       | 0.015                    | 0.029                         |
|                            | SD/ESP                      | 0.056                    | 0.11                          |
|                            | ESP                         | 0.55                     | 1.1                           |
|                            | DSI/FF                      | 0.016                    | 0.032                         |
| Mass Burn/Rotary Waterwall | DSI/FF                      | 0.012                    | 0.024                         |
| Mass Burn/Refractory Wall  | UN                          | 5.7                      | 1.1                           |
|                            | ESP                         | 0.10                     | 0.20                          |
|                            | DSI/ESP                     | 0.044                    | 0.089                         |
| Refuse-Derived Fuel-Fired  | UN                          | 4.4                      | 8.7                           |
|                            | SD/FF                       | 0.0                      | 0.0                           |
|                            | SD/ESP                      | 0.042                    | 0.084                         |
|                            | ESP                         | 0.083                    | 0.17                          |
| Modular/Excess Air         | DSI/FF                      | 0.0081                   | 0.016                         |
| Modular/Starved Air        | UN                          | 1.2                      | 2.4                           |
|                            | ESP                         | 0.23                     | 0.46                          |

Source: Reference 18.

<sup>a</sup>UN = uncontrolled, SD = spray dryer, FF = fabric filter, ESP = electrostatic precipitator, DSI = duct sorbent injection.

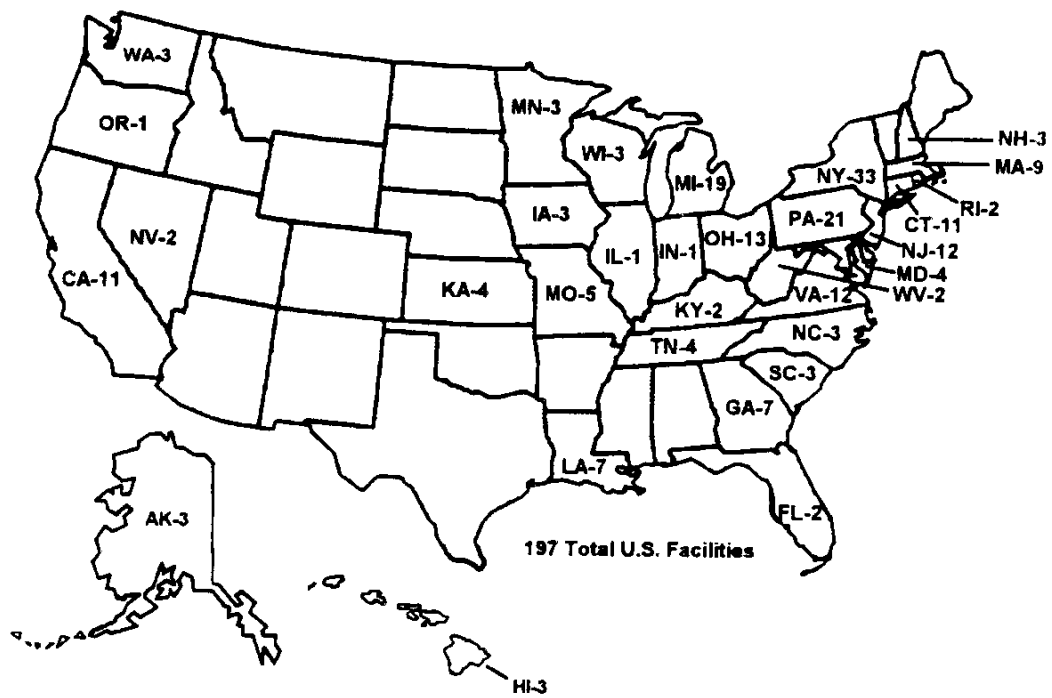

Figure 6-1. Distribution of sewage sludge incinerators in the U.S.<sup>60</sup>



## Process Description<sup>8,22</sup>

Figure 6-2 presents a simplified diagram of the sewage sludge incineration process, which involves two primary steps. The first step in the process of sewage sludge incineration is the dewatering of the sludge. Sludge is generally dewatered until it is about 15 to 30 percent solids. When it is more than 25 percent solids, the sludge will usually burn without auxiliary fuel. After dewatering, the sludge is sent to the incinerator, and thermal oxidation occurs. The unburned residual ash is removed from the incinerator, usually on a continuous basis, and is disposed. A portion of the noncombustible waste, as well as unburned volatile organic compounds, is carried out of the combustor through entrainment in the exhaust gas stream. Air pollution control devices, primarily wet scrubbers, are used to remove the entrained pollutants from the exhaust gas stream. The gas stream is then exhausted, and the collected pollutants are sent back to the head of the wastewater treatment plant in the scrubber effluent. As shown in Figure 6-2, the primary source of cadmium emissions from the SSI process is the combustion stack. Some fugitive emissions may be generated from ash handling, but the quantities are expected to be small. Because cadmium is relatively volatile, most cadmium will leave the combustion chamber as fine PM in the exhaust gas, although some cadmium may be found in the ash residue.

The paragraphs below briefly describe the three primary SSI processes used in the United States. References 8 and 22 provide more detailed descriptions and process diagrams.

The basic multiple hearth furnace is cylindrical in shape and is oriented vertically. The outer shell is constructed of steel, lined with refractory, and surrounds a series of horizontal refractory hearths. A hollow cast iron rotating shaft

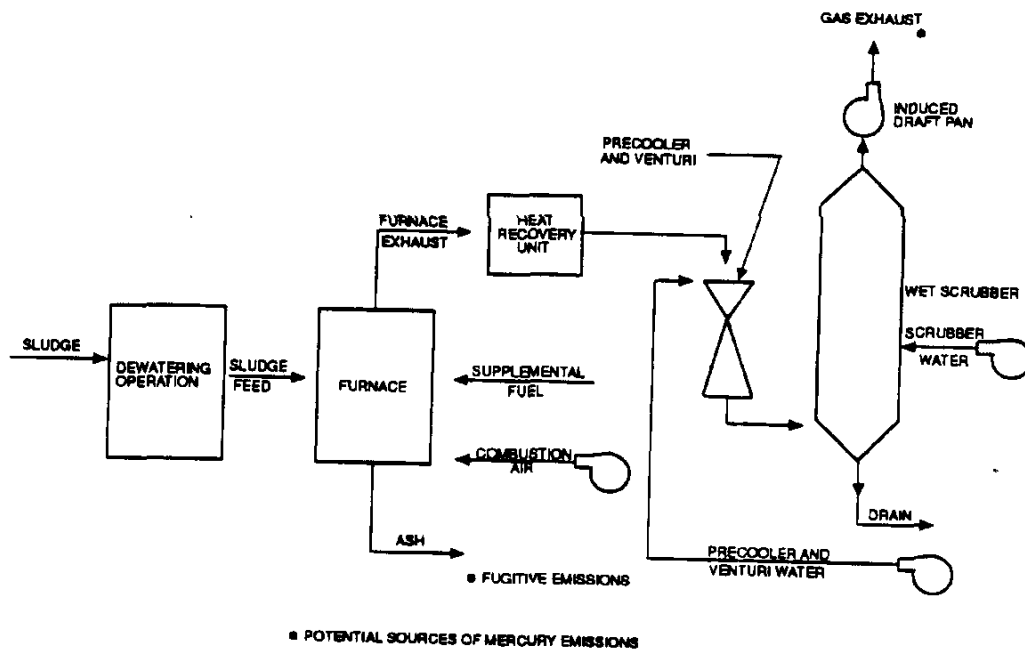

Figure 6-2. Process flow diagram for sludge incineration.

runs through the center of the hearths. Cooling air for the center shaft and rabble arms is introduced into the shaft by a fan located at its base. Attached to the central shaft are the rabble arms with teeth shaped to rake the sludge in a spiral motion, alternating in direction from the outside in, then inside out, between hearths. Typically, the upper and lower hearths are fitted with four rabble arms, and the middle hearths are fitted with two. Burners that provide auxiliary heat are located in the sidewalls of the hearths.

Partially dewatered sludge is typically fed onto the perimeter of the top hearth. Typically, the rabble arms move the sludge through the incinerator as the motion of the rabble arms rakes the sludge toward the center shaft, where it drops through holes located at the center of the hearth. This process is repeated in all of the subsequent hearths, with the sludge moving in opposite directions in adjacent hearths. The effect of the rabble motion is to break up solid material to allow better surface contact with heat and oxygen.

Ambient air is first ducted through the central shaft and its associated rabble arms. This air is then taken from the top of the shaft and recirculated onto the lowermost hearth as preheated combustion air. The combustion air flows upward through the drop holes in the hearths, countercurrent to the flow of the sludge, before being exhausted from the top hearth.

Multiple hearth furnaces can be divided into three zones. The upper hearths comprise the drying zone where most of the moisture in the sludge is evaporated. The temperature in the drying zone is typically between 425° and 760°C (800° and 1400°F). Sludge combustion occurs in the middle hearths (second zone) as the temperature is increased between 815° and 925°C (1500° and 1700°F). When exposed to the temperatures in both

upper zones, most cadmium will be volatilized, condense on small particles, and then be discharged as fine PM in the exhaust gas. Some of the cadmium may be partitioned with the ash. The third zone, made up of the lowermost hearth(s), is the cooling zone. In this zone, the ash is cooled as its heat is transferred to the incoming combustion air.

Fluidized-bed combustors (FBC's) are cylindrically shaped and oriented vertically. The outer shell is constructed of steel and is lined with refractory. Tuyeres (nozzles designed to deliver blasts of air) are located at the base of the furnace within a refractory-lined grid. A bed of sand rests upon the grid. Partially dewatered sludge is fed into the bed of the furnace. Air injected through the tuyeres, at pressures from 20 to 35 kPa (3 to 5 psig), simultaneously fluidizes the bed of hot sand and the incoming sludge. Temperatures of 725° to 825°C (1350° to 1500°F), which are sufficient to vaporize most cadmium contained in the sludge, are maintained in the bed. As the sludge burns, fine ash particles, including cadmium, are carried out the top of the furnace with the exhaust gas.

An electric incinerator consists of a horizontally oriented, insulated furnace. A woven wire belt conveyor extends the length of the furnace, and infrared heating elements are located in the roof above the conveyor belt. Combustion air is preheated by the flue gases and is injected into the discharge end of the furnace. Electric incinerators consist of a number of prefabricated modules which can be linked together to provide the necessary furnace length. The dewatered sludge cake is conveyed into one end of the incinerator. An internal roller mechanism levels the sludge into a continuous layer approximately 2.5 centimeters (cm) (1 inch [in.]) thick across the width of the belt. The sludge is sequentially dried and then burned as it moves beneath the infrared heating elements. Ash is discharged into a hopper at

the opposite end of the furnace. The preheated combustion air enters the furnace above the ash hopper and is further heated by the outgoing ash. The direction of air flow is countercurrent to the movement of the sludge along the conveyor.

### Emission Control Measures<sup>22,24</sup>

Most SSI's are equipped with some type of wet scrubbing system for PM control. Because these systems provide gas cooling as well as PM removal, they can provide some cadmium control. The paragraphs below briefly describe the wet scrubbing systems typically used on existing SSI's.

Wet scrubber controls on SSI's range from low pressure drop spray towers and wet cyclones to higher pressure drop venturi scrubbers and venturi/impingement tray scrubber combinations. The most widely used control device applied to a multiple hearth incinerator is the impingement tray scrubber. Older units use the tray scrubber alone while combination venturi/impingement tray scrubbers are widely applied to newer multiple hearth incinerators and to fluidized-bed incinerators. Most electric incinerators and some fluidized-bed incinerators use venturi scrubbers only.

In a typical combination venturi/impingement tray scrubber, hot gas exits the incinerator and enters the precooling or quench section of the scrubber. Spray nozzles in the quench section cool the incoming gas, and the quenched gas then enters the venturi section of the control device. Venturi water is usually pumped into an inlet weir above the quencher. The venturi water enters the scrubber above the throat and floods the throat completely. Most venturi sections come equipped with variable throats to allow the pressure drop to be increased, thereby increasing PM efficiency. At the base of the flooded elbow, the

gas stream passes through a connecting duct to the base of the impingement tray tower. Gas velocity is further reduced upon entry to the tower as the gas stream passes upward through the perforated impingement trays. Water usually enters the trays from inlet ports on opposite sides and flows across the tray. As gas passes through each perforation in the tray, it creates a jet that bubbles up the water and further entrains solid particles. At the top of the tower is a mist eliminator to reduce the carryover of water droplets in the stack effluent gas.

According to the literature, the control of cadmium emissions with wet scrubber controls is expected to be less than the control of total PM emissions. In a study of emissions from four municipal wastewater sludge incinerator, three multiple hearth and one fluidized-bed, cadmium and other heavy metals were found to be enriched in the fine particles, which are not as efficiently removed by scrubbers as larger particles.<sup>24</sup> The efficiency data for cadmium emissions control for sewage sludge incineration are very limited and, therefore, are not completely reliable. Based on two tests reported in Reference 22, an average cadmium control efficiency of 75 percent can be achieved with a combination of venturi scrubber and impingement scrubber systems. By contrast, based on the results of three other tests, an average of 95 percent control of PM can be achieved with an impingement scrubber alone. About 86 percent PM control was achieved with a venturi scrubber in another test.

### Emissions

As a part of the recent update of AP-42, data have been developed on cadmium emissions from SSI's.<sup>22</sup> These data are tabulated in Appendix B, Table B-3 and summarized in Table 6-20. Because no data are available on cadmium concentrations in

TABLE 6-20. SUMMARY OF CADMIUM EMISSION FACTORS  
FOR SEWAGE SLUDGE INCINERATION

| Incinerator type <sup>a</sup> | Control status <sup>b</sup> | No. data points | Cadmium emission factors |         |                                    |         |
|-------------------------------|-----------------------------|-----------------|--------------------------|---------|------------------------------------|---------|
|                               |                             |                 | g/Mg dry solids          |         | 10 <sup>-3</sup> lb/ton dry solids |         |
|                               |                             |                 | Range                    | Average | Range                              | Average |
| MH                            | UN                          | 4               | 0.0010-49                | 26      | 0.0020-98                          | 53      |
| MH                            | VS                          | 2               | 0.17-0.65                | 0.41    | 0.34-1.3                           | 0.82    |
| MH                            | IS                          | 2               | 1.2-1.5                  | 1.4     | 2.4-3.0                            | 2.7     |
| MH                            | VS/IS or VS/IS/AB           | 5               | 0.32-7.8                 | 3.0     | 0.64-16                            | 5.9     |
| MH                            | CY                          | 3               | 0.86-32                  | 12      | 1.7-65                             | 25      |
| MH                            | CY/VS or CY/VS/IS           | 2               | 8.1-25                   | 17      | 16-50                              | 33      |
| MH                            | ESP                         | 1               | ---                      | 0.17    | ---                                | 0.35    |
| MH                            | FF                          | 1               | ---                      | 0.014   | ---                                | 0.028   |
| FB                            | IS or VS/IS                 | 5               | 0.0030-1.4               | 0.48    | 0.0060-2.9                         | 0.97    |

Source: Reference 22.

<sup>a</sup>MH = multiple hearth, FB = fluidized-bed.

<sup>b</sup>UN = uncontrolled, VS = venturi scrubber, IS = impingement scrubber, AB = afterburner, CY = cyclone, ESP = electrostatic precipitator, FF = fabric filter.

sludge, the test data in Table 6-20 represent the best typical emission factors for sewage sludge incineration.

#### MEDICAL WASTE INCINERATION

Medical waste includes infectious and noninfectious wastes generated by a variety of facilities engaged in medical care, veterinary care, or research activities such as hospitals, clinics, doctors' and dentists' offices, nursing homes, veterinary clinics and hospitals, medical laboratories, and medical and veterinary schools and their research units. Medical waste is defined by the U. S. EPA as "any solid waste which is generated in the diagnosis, treatment, or immunization of human beings or animals, in research pertaining thereto, or in the production or testing of biologicals." A medical waste incinerator (MWI) is any device that burns such medical waste.<sup>25</sup>

Recent estimates developed by EPA suggest that about 3.06 million Mg (3.36 million tons) of medical waste are produced annually in the United States. Approximately 5,000 MWI's, which are distributed geographically throughout the United States, are used to treat this waste. Of these 5,000 units, about 3,000 are located at hospitals; about 150 are larger commercial facilities; and the remainder are distributed among veterinary facilities, nursing homes, laboratories, and other miscellaneous facilities.<sup>26</sup>

Available information indicates that these MWI systems can be significant sources of cadmium emissions. Cadmium emissions result from cadmium-bearing materials contained in the waste. Although concentrations of specific metals in the waste have not been fully characterized, known cadmium sources in medical waste include batteries, pigments, and plastics. Batteries, primarily nickel-cadmium and mercury-cadmium batteries, are a major cadmium



source. Mercury-cadmium batteries are used in transistorized equipment, hearing aids, watches, calculators, computers, smoke detectors, tape recorders, regulated power supplies, radiation detection meters, scientific equipment, pagers, oxygen and metal monitors, and portable electrocardiogram monitors. The nickel-cadmium battery is the most widely used rechargeable household battery and is used in computers, hearing aids, and pocket calculators. Cadmium pigments are primarily used in plastics but are also used in paints, enamels, printing inks, rubber, paper, and painted textiles.<sup>27</sup> Plastics are used in disposable instruments, syringes, petri dishes, plastic containers, packaging, bedpans, urine bags, respiratory devices, dialysis equipment, etc.<sup>28</sup> All of these materials can be routed to an MWI, thereby contributing to cadmium emissions from this source category.

#### Process Description

Although the ultimate destination of almost all medical waste produced in the United States is a solid waste landfill, the waste generally must be treated before it can be landfilled. The primary functions of MWI facilities are to render the waste biologically innocuous and to reduce the volume and mass of solids that must be landfilled by combusting the organic material contained in the waste. Over the years, a wide variety of MWI system designs and operating practices have been used to accomplish these functions. To account for these system differences, a number of MWI classification schemes have been used in past studies, including classification by waste type (pathological, mixed medical waste, red bag waste, etc.), classification by operating mode (continuous, intermittent, batch), and classification by combustor design (retort, fixed-hearth, pulsed-hearth, rotary kiln, etc.). Some insight into MWI processes, emissions, and emissions control is provided

by each of these schemes. However, because the available evidence suggests that cadmium emissions are affected primarily by waste characteristics, the characterization and control of cadmium emissions from MWI's can be discussed without considering other MWI design and operating practices in detail. The paragraphs below provide a generic MWI process description and identify potential sources of cadmium emissions. More detailed descriptions of specific MWI design and operating practices can be found in References 29 through 31.

A schematic of a generic MWI system that identifies the major components of the system is shown in Figure 6-3. As indicated in the schematic, most MWI's are multiple-chamber combustion systems that comprise primary, secondary, and possibly tertiary chambers. The primary components of the MWI process are the waste-charging system, the primary chamber, the ash handling system, the secondary chamber, and the combustion gas system, which are discussed briefly below.

Medical waste is introduced to the primary chamber via the waste-charging system. The waste can be charged either manually or mechanically. With manual charging, which is used only on batch and smaller (generally older) intermittent units, the operator opens a charge door on the side of the primary chamber and tosses bags or boxes of waste into the unit. When mechanical feed systems are employed, some type of mechanical device is used to charge the waste to the incinerator. The most common mechanical feed system is the hopper/ram assembly. In a mechanical hopper/ram feed system, the following steps take place: (1) waste is placed into a charging hopper manually, and the hopper cover is closed; (2) a fire door isolating the hopper from the incinerator opens; (3) the ram moves forward to push the waste into the incinerator; (4) the ram reverses to a location behind the fire door; (5) after the fire door closes, a water

6-64

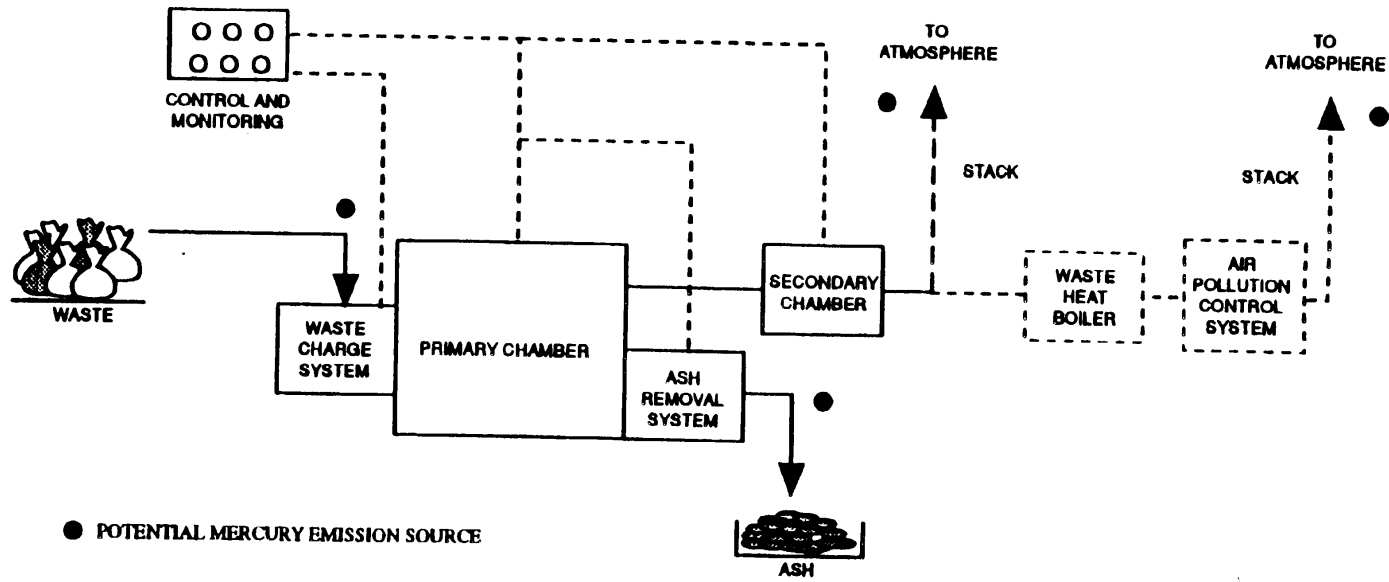

Figure 6-3. Major components of a medical waste incineration system.

spray cools the ram, and the ram retracts to the starting position; and (6) the system is ready to accept another charge. The entire hopper/ram charging sequence normally functions as a controlled, automatically-timed sequence to eliminate overcharging. The sequence can be activated by the operator or for larger, fully automated incinerators, it may be activated at preset intervals by an automatic timer.<sup>30,31</sup>

The potential for cadmium emissions from the waste-charging systems is low. Mechanical systems are generally operated with a double-door system to minimize fugitive emissions. Small quantities of fugitive emissions may be generated while the chamber door is open during manual charging, but no data are available on the magnitude of these emissions.

The primary chamber (sometimes called the "ignition" chamber) accepts the waste and begins the combustion process. Most modern MWI's operate this chamber in a "controlled-air" mode to maintain combustion air levels at or below stoichiometric requirements. The objectives of this controlled-air operation are to provide a more uniform release of volatile organic materials to the secondary chamber and to minimize entrainment of solids in these off-gases. Three processes occur in the primary chamber. First, the moisture in the waste is volatilized. Second, the volatile fraction of the waste is vaporized, and the volatile gases are directed to the secondary chamber. Third, the fixed carbon remaining in the waste is combusted.

The primary chamber generates two exhaust streams--the combustion gases that pass to the secondary chamber and the solid ash stream that is discharged. Any metal compounds in the waste, including cadmium, are partitioned to these two streams in one of three ways. The metals may be retained in the primary chamber bottom ash and discharged as solid waste; they may be entrained

as PM in the combustion gases; or they may be volatilized and discharged as a vapor with the combustion gases. Because the primary chamber typically operates in the range of 650° to 820°C (1200° to 1500°F), most of the cadmium in the waste stream will be volatilized and discharged to the secondary chamber. At the lower exhaust temperatures, the cadmium condenses onto small particles and is exhausted as fine PM to the secondary chamber. A small fraction may be retained in the primary chamber bottom ash.

The primary chamber bottom ash is discharged via an ash removal system and transported to a landfill for disposal. The ash removal system may be either manual or mechanical. Typically, batch units and smaller intermittent units employ manual ash removal. After the system has shut down and the ash has cooled, the operator uses a rake or shovel to remove the ash and place it in a drum or dumpster. Some intermittent-duty MWI's and all continuously operated MWI's use a mechanical ash removal system. The mechanical system includes three major components: (1) a means of moving the ash to the end of the incinerator hearth--usually an ash transfer ram or series of transfer rams, (2) a collection device or container for the ash as it is discharged from the hearth, and (3) a transfer system to move the ash from the collection point. Generally, these automatic systems are designed to minimize fugitive emissions. For example, one type of collection system uses an ash bin sealed directly to the discharge chute or positioned within an air-sealed chamber below the hearth. A door or gate that seals the chute is opened at regular intervals to allow the ash to drop into the collection bin. When the bin is filled, the seal-gate is closed, and the bin is removed and replaced with an empty bin. In another system, the ash is discharged into a water pit. The ash discharge chute is extended into the water pit so that an air seal is maintained. The water bath quenches the ash as the ash

is collected. A mechanical device, either a rake or drag conveyor system, is used to intermittently or continuously remove the ash from the quench pit. The excess water is allowed to drain from the ash as it is removed from the pit, and the wetted ash is discharged into a collection container.

The potential for cadmium emissions from both mechanical and manual ash discharge systems is minimal. As described above, most mechanical systems have seals and provide ash wetting as described above to minimize fugitive PM emissions. While manual systems can generate substantial fugitive PM, the concentrations of cadmium have generally been shown to be quite low.<sup>32</sup> Consequently, fugitive cadmium emissions are negligible.

Almost all the cadmium that enters the primary chamber is exhausted to the secondary chamber as fine PM, although a small fraction may be partitioned with the ash. The primary function of the secondary chamber is to complete the combustion of the volatile organic compounds that was initiated in the primary chamber. Because the temperatures in the secondary chamber are typically 980°C (1800°F) or greater, essentially all of the cadmium that enters the secondary chamber will be exhausted as fine PM. The hot exhaust gases from the secondary chamber may pass through an energy recovery device (waste heat boiler or air-to-air heat exchanger) and an air pollution control system before they are discharged to the atmosphere through the combustion stack. This combustion stack is the major route of cadmium emissions from MWI's.

#### Emission Control Measures<sup>32</sup>

A number of air pollution control system configurations have been used to control PM and gaseous emissions from the MWI combustion stacks. Most of these configurations fall within the

general classes of wet systems and dry systems. Wet systems typically comprise a wet scrubber designed for PM control (venturi scrubber or rotary atomizing scrubber) in series with a packed-bed scrubber for acid gas removal and a high-efficiency mist elimination system. Most dry systems use a fabric filter for PM removal, but ESP's have been installed on some larger MWI's. These dry systems may use sorbent injection via either dry injection or spray dryers upstream from the PM device to enhance acid gas control. More detailed descriptions of MWI air pollution control systems can be found in Reference 32. The emission data presented in the section below provide information on the performance of some of the more common systems.

### Emissions<sup>33-50</sup>

Over the past 5 years, cadmium emissions have been measured at several MWI's throughout the U. S. EPA's regulatory development program, the MWI emission characterization studies conducted by the State of California, and compliance tests conducted in response to State air toxic requirements. Emission data from 25 MWI's were identified in developing this L&E document. However, the data from only 18 facilities were considered adequate for emission factor development. For the remaining facilities, either process data were insufficient to develop emission factors or the test methodologies were considered unacceptable. Emission data for the 18 facilities are tabulated in Appendix B, Table B-4. The paragraphs below summarize the information on uncontrolled emissions and on the performance of emission control systems collected from these 18 facilities.

The uncontrolled emission data collected at 13 facilities showed substantial variability, with cadmium emission factors ranging from 0.12 to 22 g/Mg of waste charged ( $2.4 \times 10^{-4}$  to

$4.4 \times 10^{-2}$  lb/ton).<sup>33-41,44,47-50</sup> This range of emission factors represents a variety of waste types (mixed medical waste, red bag [infectious] waste only, and pathological waste) and a variety of incinerator types (continuous and intermittent units with varied operating practices). While the data are insufficient to demonstrate unequivocally a direct relationship between waste characteristics and emissions, the data strongly suggest that most of this variability is related to differences in the cadmium content of the waste. First, characterization of the bottom ash at several facilities showed little cadmium in the ash, indicating that most of the cadmium in the waste is discharged with the combustion gases. Second, as part of an EPA study, wastes from two different hospitals were fired to the same incinerator under comparable operating conditions. There was an almost threefold difference in the average emission factors for the two wastes, with wastes from the smaller hospital yielding an emission factor of 1.6 g/Mg ( $3.1 \times 10^{-3}$  lb/ton) and those from the larger hospital yielding a factor of 4.4 g/Mg ( $8.8 \times 10^{-3}$  lb/ton), again providing evidence of waste-related variation. Although there has been some speculation that the higher emission factors result from having cadmium-bearing items, such as batteries, pigments, and plastics in the waste stream, insufficient information is available to define conclusively those waste attributes that affect cadmium emissions.

Because emissions are strongly related to waste characteristics, separate uncontrolled emission factors were developed for the different waste types. These emission factors are summarized in Table 6-21. Substantially greater information is available for mixed medical waste incineration than for either red bag or pathological waste incineration. Consequently, the mixed waste results are considered to be a more reliable indicator of the range of emission factors likely to be found across the MWI population than are the red bag or pathological



TABLE 6-21. UNCONTROLLED CADMIUM EMISSION FACTORS  
FOR MEDICAL WASTE INCINERATORS

| Waste type                | No. of facilities | No. of test runs | Cadmium emission factors, g/Mg ( $10^{-3}$ lb/ton) |               |
|---------------------------|-------------------|------------------|--|---------------|
|                           |                   |                  | Range  | Average       |
| Mixed <sup>a</sup>        | 13                | 72               | 0.12 - 22<br>(0.24 - 44)                           | 2.5<br>(5.0)  |
| Red bag <sup>b</sup>      | 1                 | 9                | 0.72 - 2.5<br>(1.4 - 5.0)                          | 1.6<br>(3.3)  |
| Pathological <sup>c</sup> | 1                 | 6                | <0.0 - 4.7<br>(<0.0 - 9.3)                         | 0.90<br>(1.8) |

Source: References 33-41, 44, 47-50.

<sup>a</sup>Based on the range of facility averages. Number of runs for each facility ranged from 2 to 16.

<sup>b</sup>Based on the range spanned by three test averages (each test comprised three runs) at one facility.

<sup>c</sup>This emission factor is strongly influenced by a single large value. A better estimate of emissions from a "typical" facility is the trimmed mean, which is 0.18 g/Mg ( $0.37 \times 10^{-3}$  lb/ton).

results. However, because the range in emission factors is so large, even the mixed waste emission factors should be applied to individual MWI's with caution.

The emission factors for the red bag and pathological waste should be used with extreme caution because each factor is based on results from waste fired at only one facility. Two observations are noteworthy in interpreting these data. First, the red bag emission factor of 1.6 g/Mg ( $3.3 \times 10^{-3}$  lb/ton) is within the range of the emission factors for mixed medical waste. However, the wastes were generated by the same facility that had one of the largest mixed waste emission factors, so the red bag emission factor may be misleading. Second, the emission factor for pathological waste of 0.90 g/Mg ( $1.8 \times 10^{-3}$  lb/ton) is near the bottom end of the mixed waste range and could be even lower because it is strongly influenced by a single large value (4.7 g/Mg [ $9.3 \times 10^{-3}$  lb/ton]). This value is a factor of 20 larger than the second largest value. If the largest and smallest values are removed, the trimmed mean is 0.18 g/Mg ( $0.37 \times 10^{-3}$  lb/ton), which is similar to the median of the data. Hence, the emission factor of 0.18 g/Mg ( $0.37 \times 10^{-3}$  lb/ton) is recommended as the best emission factor for a typical MWI firing pathological waste. However, this low emission factor also may be misleading because tests at the same facility produced the lowest mixed waste emission factor. As evidenced by these observations, the red bag and pathological emission data are too sparse to differentiate effectively between the effects of waste type and facility-specific waste practices on cadmium emissions.

Substantially fewer data are available on controlled emissions than on uncontrolled emissions.<sup>35,36,40-46,48,50</sup> The best data available are those which characterize the performance of seven MWI air pollution control systems--a wet scrubber system, a venturi scrubber system, a venturi scrubber/packed-bed system, a

duct sorbent injection/electrostatic precipitator system, a fabric filter system, a dry injection/fabric filter system, and a spray dryer/fabric filter system. Table 6-22 presents controlled emission factors and cadmium emission control efficiencies for these air pollution control systems. Because controlled emission factors could only be developed for a few facilities, they are not likely to represent the variability across the incinerator population. Therefore, it is recommended that controlled emission factors be developed by applying the average control efficiencies to uncontrolled emission factors or emission rates rather than using the controlled emission factors presented in Table 6-22.

The performances of two of the dry systems (dry injection/fabric filter and spray dryer/fabric filter) were examined with and without carbon injection. The results from these tests and from the test of the fabric filter with no carbon injection are presented in Table B-4, Appendix B. These results indicate that the dry systems without carbon injection provided greater than 99 percent control of cadmium. For these systems, the outlet cadmium emissions range from 99.1 percent to 99.9 percent lower than the inlet emissions. This variability is considered to be well within the normal range of process and emission test method variability as described in Section 8. Consequently, the results are consistent with essentially complete removal by the control system. The dry systems with carbon injection achieve essentially the same cadmium removal as those systems without carbon injection, with control efficiencies ranging from 97.3 percent to 99.9 percent.

The emission test results for the wet systems are also presented in Table B-4, Appendix B. As shown in Table 6-22, the performance of the wet systems in controlling cadmium emissions was not as effective as that achieved by the dry systems with or

TABLE 6-22. SUMMARY OF CONTROLLED CADMIUM EMISSION FACTORS AND CONTROL EFFICIENCIES FOR MEDICAL WASTE INCINERATORS

| Waste type <sup>a</sup> | Control status <sup>b</sup> | No. of facilities | No. of runs | Cadmium emission factors <sup>c</sup> |                 |                               |                 | Control efficiency (%) |                 |
|-------------------------|-----------------------------|-------------------|-------------|---------------------------------------|-----------------|-------------------------------|-----------------|------------------------|-----------------|
|                         |                             |                   |             | g/Mg waste                            |                 | 10 <sup>-3</sup> lb/ton waste |                 | Average                | Range           |
|                         |                             |                   |             | Average                               | Range           | Average                       | Range           |                        |                 |
| M                       | WS                          | 1                 | 3           | 2.6                                   | 1.1-5.3         | 5.1                           | 2.1-11          | NA <sup>d</sup>        | NA <sup>d</sup> |
|                         | VS                          | 1                 | 3           | 0.75                                  | 0.56-0.93       | 1.5                           | 1.1-1.9         | 7.7                    | -62-49          |
|                         | VS/PB                       | 4                 | 11          | 4.3                                   | 0.71-10         | 8.5                           | 1.4-20          | 38 <sup>e</sup>        | 34-45           |
|                         | DI/ESP                      | 1                 | 3           | 0.30                                  | 0.26-0.36       | 0.59                          | 0.53-0.72       | --                     | --              |
|                         | FF                          | 1                 | 3           | <0.0026                               | <0.0025-<0.0027 | <0.0052                       | <0.0049-<0.0053 | >99.9                  | >99.8->99.9     |
|                         | DI/FF                       | 1                 | 9           | 0.0097                                | 0.0088-0.011    | 0.019                         | 0.018-0.022     | 99.6                   | 99.4-99.8       |
|                         | DI/FF+C                     | 1                 | 5           | 0.044                                 | 0.0064-0.20     | 0.088                         | 0.013-0.39      | 99.1                   | 97.3-99.9       |
|                         | SD/FF                       | 1                 | 3           | 0.021                                 | 0.010-0.029     | 0.043                         | 0.021-0.059     | 99.7                   | 99.6-99.8       |
|                         | SD/FF+C                     | 1                 | 3           | 0.012                                 | 0.0096-0.015    | 0.024                         | 0.019-0.029     | 99.8                   | 99.8-99.9       |
| RB                      | DI/FF                       | 1                 | 9           | 0.013                                 | 0.0096-0.016    | 0.026                         | 0.019-0.031     | 99.1                   | 98.6-99.5       |

Source: References 35, 36, 40-46, 48, 50.

<sup>a</sup>M = mixed medical waste, RB = red bag waste.

<sup>b</sup>WS = wet scrubber, VS = venturi scrubber, PB = packed bed scrubber, DI = dry injection  
ESP = electrostatic precipitator, FF = fabric filter, SD = spray dryer, C = carbon injection.

<sup>c</sup>Ranges are for individual runs. Averages were obtained by taking the arithmetic mean of facility averages.

<sup>d</sup>NA = not available.

<sup>e</sup>Efficiency data were available for only one facility.

without carbon injection. For the wet systems, the outlet cadmium emissions range from 160 percent higher to 49 percent lower than the inlet emissions. Table 6-23 presents the best typical uncontrolled emission factors for MWI's. To obtain best typical controlled emission factors for venturi scrubber/packed bed systems, apply a 38-percent efficiency to these uncontrolled emission factors. For dry systems with or without carbon injection, apply a 97-percent efficiency to these uncontrolled emission factors.

TABLE 6-23. BEST TYPICAL UNCONTROLLED CADMIUM EMISSION FACTORS FOR MEDICAL WASTE INCINERATORS

| Waste type   | Cadmium emission factors |                                  |
|--------------|--------------------------|----------------------------------|
|              | g/Mg of Waste            | 10 <sup>-3</sup> lb/ton of Waste |
| Mixed        | 2.5                      | 5.0                              |
| Red Bag      | 1.6                      | 3.3                              |
| Pathological | 0.18                     | 0.37                             |

## REFERENCES

1. United States Department of Energy. State Energy Data Report, Consumption Estimates, 1960-1990. Report No. DOE/EIA-0214(90). Energy Information Administration, Office of Energy Markets and End Use, United States Department of Energy, Washington, DC. May 1992.
2. Brooks, Garry. Estimating Air Toxic Emissions from Coal and Oil Combustion Sources. EPA-450/2-89-001. U. S. Environmental Protection Agency, Research Triangle Park, NC. April 1989.
3. White, D.M., L.O. Edwards, A.G. Eklund, D.A. DuBose, and F.D. Skinner. Correlation of Coal Properties with Environmental Control Technology Needs for Sulfur and Trace Elements. EPA-600/7-84-066. U. S. Environmental Protection Agency, Research Triangle Park, NC. 1984.
4. Swanson, V.E., J.H. Medlin, J.R. Hatch, S.L. Coleman, G.H. Wood, S.D. Woodruff, and R.T. Hildebrand. Collection, Chemical Analysis, and Evaluation of Coal Samples in 1975. USGS Report No. 76-468. United States Department of the Interior, Geological Survey. Washington, DC. 1976.
5. U. S. Environmental Protection Agency, Compilation of Air Pollutant Emission Factors, AP-42, Fourth Edition, Supplement B. U. S. Environmental Protection Agency, Research Triangle Park, NC. September 1988.
6. Babcock and Wilcox Company. Steam: Its Generation and Use. Babcock and Wilcox, New York, NY. 1978.
7. Letter from R.B. Finkelman, United States Department of the Interior, to D.D. Wallace, Midwest Research Institute. February 8, 1993. Metal concentrations in coal.
8. Buonicore, A.J. and W.T. Davis, eds. Air Pollution Engineering Manual. Van Nostrand Reinhold, New York, NY, 1992.
9. Boron, D.J. Controlling Toxic Emissions. Coal. June 1990.
10. Ondov, J.M., R.C. Ragaini, and A.H. Biermann. Elemental Emissions from a Coal-Fired Power Plant. Comparison of a Venturi Wet Scrubber System with a Cold-Side Electrostatic Precipitator. Environmental Science and Technology. Volume 13, Number 5. May 1979.

11. Osborne, W.E. and M.D. McDannel. Emissions of Air Toxic Species: Test Conducted Under AB2588 for the Western States Petroleum Association. Report No. CA 72600-2601. CARNOT, Tustin, CA. May 1990.
12. Pape & Steiner Environmental Services. AB2588 Testing at Texaco Trading and Transportation, Inc. Panoche Station-Heater, June 18 through June 29, 1990. Report PS-90-2187. Pape & Steiner Environmental Services Bakersfield, CA. September 1990.
13. Hopkins, K.C. and L.A Green. Air Toxics Testing at Morro Bay Unit 3. March 1-5, 1990 CARNOT, Tustin, CA. May 1990.
14. U. S. Environmental Protection Agency, Compilation of Air Pollutant Emission Factors, AP-42, Fourth Edition, Supplement E. U. S. Environmental Protection Agency, Research Triangle Park, NC. October 1992.
15. Emission Factor Documentation for AP-42 Section 1.6, Wood Waste Combustion in Boilers. U. S. Environmental Protection Agency, Research Triangle Park, NC. 1992.
16. Schultz, S. Auberry Energy, Inc. Toxic Hot Spots Report. Yanke Energy. October 1990.
17. DeAngelis, D.G., D.S. Ruffin, J.A. Peters, and R.B. Reznik. Source Assessment: Residential Wood Combustion. EPA-600/2-80-426. U. S. Environmental Protection Agency, Research Triangle Park, NC. 1980.
18. U. S. Environmental Protection Agency, Emission Factor Documentation for AP-42 Section 2.1, Refuse Combustion. U. S. Environmental Protection Agency, Research Triangle Park, NC. September 1992.
19. Radian Corporation. Municipal Waste Combustion Study. Characterization of the Municipal Waste Combustion Industry. EPA-530/SW-87-021h. U. S. Environmental Protection Agency, Washington, DC. June 1987.
20. Radian Corporation. Locating and Estimating Air Toxics Emissions from Municipal Waste Combustors. EPA-450/2-89-006. U. S. Environmental Protection Agency, Research Triangle Park, NC. April 1989.
21. Greenberg, R.R., W.H. Zoller, and G.E. Gordon. Composition and Size Distributions of Particles Released in Refuse Incineration. Environmental Science and Technology Volume 12, Number 5. May 1978.

22. U. S. Environmental Protection Agency, Emission Factor Documentation for AP-42 Section 2.5, Sewage Sludge Incineration. U. S. Environmental Protection Agency, Research Triangle Park, NC. September 1992.
23. Radian Corporation. Locating and Estimating Air Toxics Emissions from Sewage Sludge Incinerators. EPA-450/2-90-009. U. S. Environmental Protection Agency, Research Triangle Park, NC. May 1990.
24. Bennett, R.L. and K.T. Knapp. Characterization of Particulate Emissions from Municipal Wastewater Sludge Incinerators. Environmental Science and Technology. Volume 16, Number 12. December 1982.
25. Midwest Research Institute. Medical Waste Incinerators-Background Information for Proposed Standards and Guidelines: Industry Profile Report for New and Existing Facilities. Draft Report. Cary, NC. April 1992.
26. U. S. Environmental Protection Agency, Medical Waste Incinerators-Background Paper for New and Existing Facilities, Draft. U. S. Environmental Protection Agency, Research Triangle Park, NC. June 1992.
27. Franklin Associates, Ltd. Characterization of Products Containing Lead and Cadmium in Municipal Solid Waste in the United States, 1970 to 2000. EPA-530/SW-89-015A. U. S. Environmental Protection Agency, Washington, DC. January 1989.
28. Doyle, B., D. Drum, and J. Lauber. The Smoldering Question of Hospital Wastes. Pollution Engineering Magazine. July 1985.
29. Radian Corporation. Hospital Waste Combustion Study: Data Gathering Phase. EPA-450/3-88-017. U. S. Environmental Protection Agency, Research Triangle Park, NC. December 1988.
30. Neulicht, R., M. Turner, L. Chaput, D. Wallace, and S. Smith, Operation and Maintenance of Hospital Waste Incinerators. EPA-450/3-89-002. U. S. Environmental Protection Agency, Research Triangle Park, NC. March 1989.
31. Neulicht, R., L. Chaput, D. Wallace, M. Turner, and S. Smith, Hospital Incinerator Operator Training Course: Volume I Student Handbook. EPA-450/3-89-003. U. S. Environmental Protection Agency, Research Triangle Park, NC. March 1989.



32. Midwest Research Institute. Medical Waste Incinerators-Background Information for Proposed Standards and Guidelines: Control Technology Performance Report for New and Existing Facilities. Cary, NC. July 1992.
33. Bumbaco, M. J. Report on Stack Sampling Program to Measure the Emissions of Selected Trace Organic Compounds, Particulates, Heavy Metals and HCl from the Royal Jubilee Hospital Incinerator, Victoria, BC. Environment Canada. April 1983.
34. McCormack, J., P. Ouchida, and G. Lew. Evaluation Test on a Small Hospital Refuse Incinerator, Saint Bernadines Hospital, San Bernadino, California, ARB/ML-89-028. California Air Resources Board, Sacramento, CA. July 1989.
35. England, G., D. Hansell, J. Newhall, and N. Soelberg. Michigan Hospital Incinerator Emissions Test Program, Volume II: Site Summary Report Borgess Medical Center Incinerator. Energy and Environmental Research Corporation, Irvine, CA. August 1991.
36. England, G., D. Hansell, J. Newhall, and N. Soelberg. Michigan Hospital Incinerator Emissions Test Program, Volume III: Site Summary Report University of Michigan Medical Center Incinerator, Energy and Environmental Research Corporation, Irvine, CA. August 1991.
37. Radian Corporation. Medical Waste Incineration Emission Test Report, Lenoir Memorial Hospital, Kinston, North Carolina, EMB Report 90-MWI-3. U. S. Environmental Protection Agency, Research Triangle Park, NC. May 1990.
38. Radian Corporation. Medical Waste Incineration Emission Test Report, Cape Fear Memorial Hospital, Wilmington, North Carolina. EMB Report 90-MWI-4. U. S. Environmental Protection Agency, Research Triangle Park, NC. November 1990.
39. Radian Corporation. Medical Waste Incineration Emission Test Report, AMI Central Carolina Hospital, Sanford, North Carolina. EMB Report 90-MWI-5. U. S. Environmental Protection Agency, Research Triangle Park, NC. December 1990.
40. Radian Corporation. Medical Waste Incineration Emission Test Report, Borgess Medical Center, Kalamazoo, Michigan. EMB Report 91-MWI-9. U. S. Environmental Protection Agency, Research Triangle Park, NC. December 1991.

41. Radian Corporation. Medical Waste Incineration Emission Test Report, Morristown Memorial Hospital, Morristown, New Jersey. EMB Report 91-MWI-8. U. S. Environmental Protection Agency, Research Triangle Park, NC. December 1991.
42. ETS, Inc. Compliance Testing for Southland Exchange Joint Venture, Hampton, South Carolina. ETS, Inc., Roanoke, VA. July 1989.
43. Source Test Report, MEGA of Kentucky. August 1988.
44. U. S. Environmental Protection Agency. Emission Factor Documentation for AP-42 Section 2.6, Medical Waste Incineration. U. S. Environmental Agency, Research Triangle Park, NC. September 1992.
45. Air Management Services. Emissions Test Report for Fox-Chase Cancer Center, Philadelphia, PA. February 1989.
46. AirNova, Inc. Emission Compliance Test Program for Nazareth Hospital, Philadelphia, PA. September 1989.
47. Jenkins, A., P. Ouchida, and G. Lew. Evaluation Retest on a Hospital Refuse Incinerator at Sutter General Hospital, Sacramento, California, ARB/ML-88-026. California Air Resources Board, Sacramento, CA. April 1988.
48. Jenkins, A., P. Ouchida, and G. Lew. Evaluation Test on a Refuse Incinerator at Stanford University Environmental Safety Facility, Stanford, California, ARB/ML-88-025. California Air Resources Board, Sacramento, CA. April 1988.
49. Jenkins, A., P. Ouchida, and D. Simeroth. Evaluation Test on a Hospital Refuse Incinerator at Saint Agnes Medical Center, Fresno, California, ARB/SS-87-01. California Air Resources Board, Sacramento, CA. January 1987.
50. Jenkins, A., C. Castronovo, G. Lindner, P. Ouchida, and D. Simeroth. Evaluation Test on a Hospital Refuse Incinerator at Cedars Sinai Medical Center, Los Angeles, California, ARB/SS-87-11. California Air Resources Board, Sacramento, CA. April 1987.

## SECTION 7

### EMISSIONS FROM NONFERROUS SMELTING/REFINING

Cadmium is emitted from various nonferrous smelting and refining operations including the following:

1. Primary lead smelting;
2. Primary copper smelting;
3. Primary zinc smelting and refining--electrolytic process;
4. Primary zinc smelting and refining--electrothermic process;
5. Secondary copper smelting and refining;
6. Secondary zinc recovery from metallic scrap; and
7. Secondary zinc recovery from steel production.

Raw materials processed at the facilities listed above include minerals and ores extracted from the earth, as well as metallic waste from miscellaneous products. These raw materials contain cadmium. At various stages of manufacturing, the raw materials are processed at elevated temperatures, therefore resulting in cadmium being emitted from the raw materials. This section presents process information, air pollution control measures, and estimates of cadmium emissions from these sources.

#### PRIMARY LEAD SMELTING

Lead is recovered from a sulfide ore, primarily galena (lead sulfide [PbS]), which also contains small amounts of copper, iron, zinc, and other trace elements. Cadmium also can be expected to be present in the lead ore. One data source has

reported that the cadmium content in lead ore is approximately 0.02 percent.<sup>1</sup>

A list of primary lead smelters currently in operation within the United States (U.S.) is given in Table 7-1.<sup>2</sup>

TABLE 7-1. DOMESTIC PRIMARY LEAD SMELTERS AND REFINERIES

| Smelter  | Refinery          | 1990 Production, Mg (tons) |
|--|-------------------|----------------------------|
| ASARCO, East Helena, MT                        | ASARCO, Omaha, NE | 61,000 (67,000)            |
| ASARCO, Glover, MO                             | Same site         | 112,000 (123,200)          |
| Doe Run (formerly St. Joe),<br>Herculaneum, MO | Same site         | 231,000 (254,100)          |

Source: Reference 2.

A description of the process used to manufacture lead and a discussion of the emissions resulting from the various operations are presented below.

### Process Description<sup>3</sup>

Figure 7-1 contains a process flow diagram for primary lead smelting. The recovery of lead from the lead ore consists of three main steps: sintering, reduction, and refining.

Sintering is carried out in a sintering machine, which is a continuous steel pallet conveyor belt. Each pallet consists of perforated grates, and beneath the grates are wind boxes, which are connected to fans to provide a draft through the moving sinter charge. The sintering reactions take place at about 1000°C (1832°F) during which lead sulfide is converted to lead

7-3

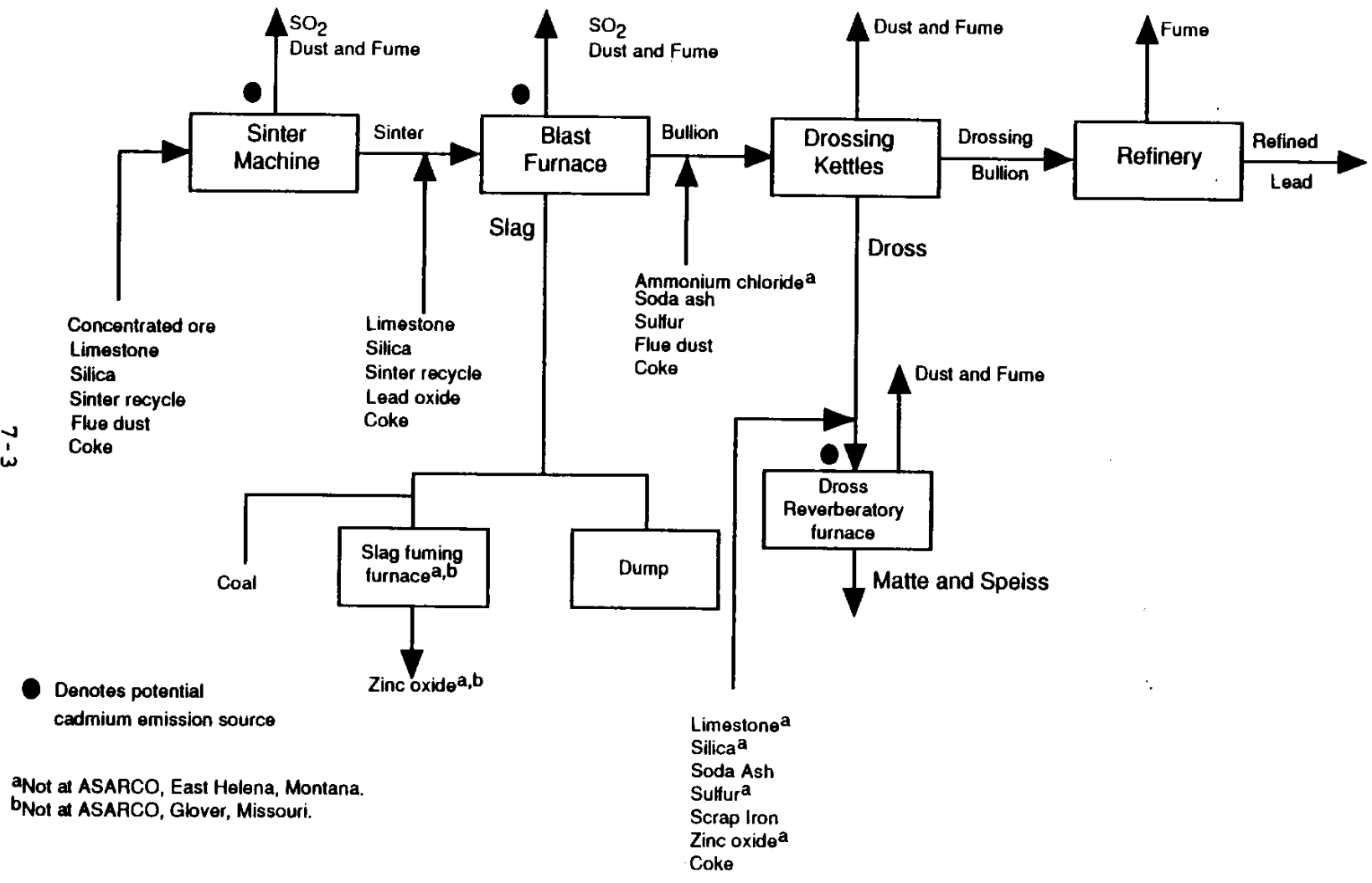

Figure 7-1. Typical primary lead-processing scheme.<sup>90</sup>

oxide and lead sulfate. Since cadmium boils at approximately 767°C (1415°F), most of the cadmium in the ore can be expected to be emitted during sintering.

Reduction of the sintered lead is carried out in a blast furnace at a temperature of 1600°C (2912°F). The furnace is charged with a mixture of sinter (80 to 90 percent of charge); metallurgical coke (8 to 14 percent of charge); and other materials, such as limestone, silica, litharge, and unspecified slag-forming constituents. In the blast furnace, the sinter is reduced to lead. The level of heat needed to create the reaction is supplied by coke combustion. Slag, consisting of impurities, is continuously collected from the furnace and is either processed at the smelter (for its metal content) or shipped to treatment facilities. The impurities include arsenic, antimony, copper sulfide and other metal sulfides, and silicates. Lead bullion, which is the primary product, undergoes a preliminary treatment to remove impurities, such as copper, sulfur, arsenic, antimony, and nickel, before further refining occurs. Any residual cadmium left in the ore can be expected to be emitted during the reduction step. Refining of the lead bullion is carried out in cast iron kettles. Refined lead, which is 99.99 to 99.999 percent pure, is cast into pigs for shipment.

### Emission Control Measures<sup>3</sup>

Cadmium emission sources are indicated in Figure 7-1 by solid circles. Emission controls on lead smelter operations are used for controlling particulate matter (PM) and sulfur dioxide (SO<sub>2</sub>) emissions resulting from the blast furnace and sintering machines. Centrifugal collectors (cyclones) are used in conjunction with fabric filters or electrostatic precipitators (ESP's) for PM control. Because cadmium has a boiling point of approximately 767°C (1415°F), most of the cadmium will

potentially condense in the cyclone. Thus, a high degree of control of cadmium emissions may be achieved in the fabric filter or ESP. However, no data on the effectiveness of fabric filters and ESP's in controlling cadmium emissions are available.

Control of SO<sub>2</sub> is achieved by absorption to form sulfuric acid in the sulfuric acid plants, which are commonly part of lead-smelting plants.

Emissions

Cadmium, which may exist in the ore at a 0.02-percent concentration, can potentially be emitted when temperatures reach high levels in the sintering and reducing steps. Because the sintering step is carried out at temperatures much higher than the boiling point of cadmium, the sintering step is considered to be the primary source of cadmium emissions. Table 7-2 presents estimates of cadmium emissions reported by three facilities during 1990, as required under Superfund Amendments and Reauthorization Act (SARA) Title III regulations.<sup>4</sup>

TABLE 7-2. PRIMARY LEAD PRODUCERS REPORTING CADMIUM EMISSIONS IN THE 1990 TOXICS RELEASE INVENTORY

| Smelter                      | Emissions, kg (lbs) |                |                |
|------------------------------|---------------------|----------------|----------------|
|                              | Nonpoint            | Point          | Total          |
| ASARCO Inc., Glover, MO      | 111 (245)           | 415 (914)      | 526 (1,159)    |
| ASARCO Inc., East Helena, MT | 3,175 (6,985)       | 4,990 (10,978) | 8,165 (17,963) |
| Doe Run, Herculaneum, MO     | 47 (104)            | 5,526 (12,157) | 5,573 (12,261) |

Source: Reference 4.

Test data pertaining to cadmium emissions from the various operations are not available. Table 7-3 presents cadmium emission factors reported in the USEPA data base, SPECIATE, for various operations during primary lead smelting.<sup>5</sup> Because the validity of these emission factors cannot be verified, extreme caution should be exercised when using these factors.

#### PRIMARY COPPER SMELTING

The principal method for recovering copper from sulfide ore is pyrometallurgical smelting. Copper ores contain significant quantities of arsenic, cadmium, lead, antimony, and other heavy metals. One data source has reported that cadmium content in lead ore is approximately 0.01 percent.<sup>6</sup>

A list of primary copper smelters currently operating within the U.S. is given in Table 7-4.<sup>7</sup> A description of the process used to manufacture copper and a discussion of the emissions resulting from the various operations are presented below.

#### Process Description<sup>8</sup>

A conventional pyrometallurgical copper-smelting process is illustrated in Figure 7-2. This process includes roasting ore concentrates to produce calcine, smelting of roasted (calcine feed) or unroasted (green feed) ore concentrates to produce matte, and converting the matte to yield blister copper product (about 99 percent pure). Typically, the blister copper is refined in an anode furnace, cast into "anodes", and then sent to an electrolytic refinery for further impurity elimination.

In roasting, charge material of copper concentrate, mixed with a siliceous flux (often a low grade ore), is heated in air to about 650°C (1200°F), eliminating 20 to 50 percent of the



TABLE 7-3. CADMIUM EMISSION FACTORS FOR LEAD-SMELTING FACILITIES

| Emission source                        | Source classification code (SCC) | Cadmium emission factor <sup>a</sup> |                      |
|--|----------------------------------|--------------------------------------|----------------------|
|  |                                  | lb/ton                               | kg/Mg                |
| Sintering: single stream               | 30301001                         | 1.39941 <sup>b</sup>                 | 0.7 <sup>b</sup>     |
| Blast furnace operation                | 30301002                         | 41.74965 <sup>b</sup>                | 20.9 <sup>b</sup>    |
| Dross reverberatory furnace            | 30301003                         | 0.2438 <sup>b</sup>                  | 0.1219 <sup>b</sup>  |
| Ore crushing                           | 30301004                         | 0.01668 <sup>c</sup>                 | 0.00834 <sup>c</sup> |
| Sintering: dual stream feed end        | 30301006                         | 9.67987 <sup>b</sup>                 | 4.84 <sup>b</sup>    |
| Slag fume furnace                      | 30301008                         | 0.00359 <sup>d</sup>                 | 0.0018 <sup>d</sup>  |
| Lead drossing                          | 30301009                         | 0.00203 <sup>d</sup>                 | 0.001 <sup>d</sup>   |
| Raw material crushing and grinding     | 30301010                         | 0.04553 <sup>d</sup>                 | 0.023 <sup>d</sup>   |
| Raw material unloading                 | 30301011                         | 0.00334 <sup>e</sup>                 | 0.00167 <sup>e</sup> |
| Raw material storage piles             | 30301012                         | 0.0025 <sup>e</sup>                  | 0.00125 <sup>e</sup> |
| Raw material transfer                  | 30301013                         | 0.00417 <sup>e</sup>                 | 0.00209 <sup>e</sup> |
| Sintering charge mixing                | 30301014                         | 0.01885 <sup>e</sup>                 | 0.00943 <sup>e</sup> |
| Sinter crushing/screening              | 30301015                         | 0.06829 <sup>f</sup>                 | 0.03415 <sup>f</sup> |
| Sinter transfer                        | 30301016                         | 0.00911 <sup>f</sup>                 | 0.00456 <sup>f</sup> |
| Sinter fines return handling           | 30301017                         | 0.40977 <sup>f</sup>                 | 0.2049 <sup>f</sup>  |
| Blast furnace tapping (metal and slag) | 30301019                         | 0.00728 <sup>d</sup>                 | 0.00364 <sup>d</sup> |
| Blast furnace lead pouring             | 30301020                         | 0.04234 <sup>d</sup>                 | 0.02117 <sup>d</sup> |
| Blast furnace slag pouring             | 30301021                         | 0.00075 <sup>d</sup>                 | 0.00038 <sup>d</sup> |
| Lead refining/silver retort            | 30301022                         | 0.08195 <sup>d</sup>                 | 0.04098 <sup>d</sup> |
| Lead casting                           | 30301023                         | 0.03961 <sup>d</sup>                 | 0.0198 <sup>d</sup>  |
| Reverberatory or kettle softening      | 30301024                         | 0.13659 <sup>d</sup>                 | 0.0683 <sup>d</sup>  |
| Sinter machine leakage                 | 30301025                         | 0.02519 <sup>f</sup>                 | 0.0126 <sup>f</sup>  |
| Sinter dump area                       | 30301026                         | 0.00046 <sup>f</sup>                 | 0.00023 <sup>f</sup> |

Source: Reference 5.

<sup>a</sup>All emission factors are reported as found in the SPECIATE data base without rounding off (Reference 5). Emission factors in SPECIATE data base are reported in lb/ton of process activity.

<sup>b</sup>lb/ton (kg/Mg) of concentrated ore.

<sup>c</sup>lb/ton (kg/Mg) of ore crushed.

<sup>d</sup>lb/ton (kg/Mg) of lead product.

<sup>e</sup>lb/ton (kg/Mg) of raw material.

<sup>f</sup>lb/ton (kg/Mg) of sinter.

TABLE 7-4. DOMESTIC PRIMARY COPPER SMELTERS AND REFINERIES

| Smelter                            | 1992 Capacity, Mg (tons) |
|------------------------------------|--------------------------|
| ASARCO Inc., Hayden, AZ            | 170,000 (187,000)        |
| Cyprus Miami Mining Co., Globe, AZ | 180,000 (198,000)        |
| MAGMA Copper Co., San Manuel, AZ   | 290,000 (319,000)        |
| Copper Range Co., White Pine, MI   | 60,000 (66,000)          |
| Phelps Dodge, Hidalgo, NM          | 190,000 (209,000)        |
| Chino Mines Co., Hurley, NM        | 170,000 (187,000)        |
| ASARCO Inc., El Paso, TX           | 104,000 (114,400)        |
| Kennecott, Garfield, UT            | 210,000 (231,000)        |

Source: Reference 7.

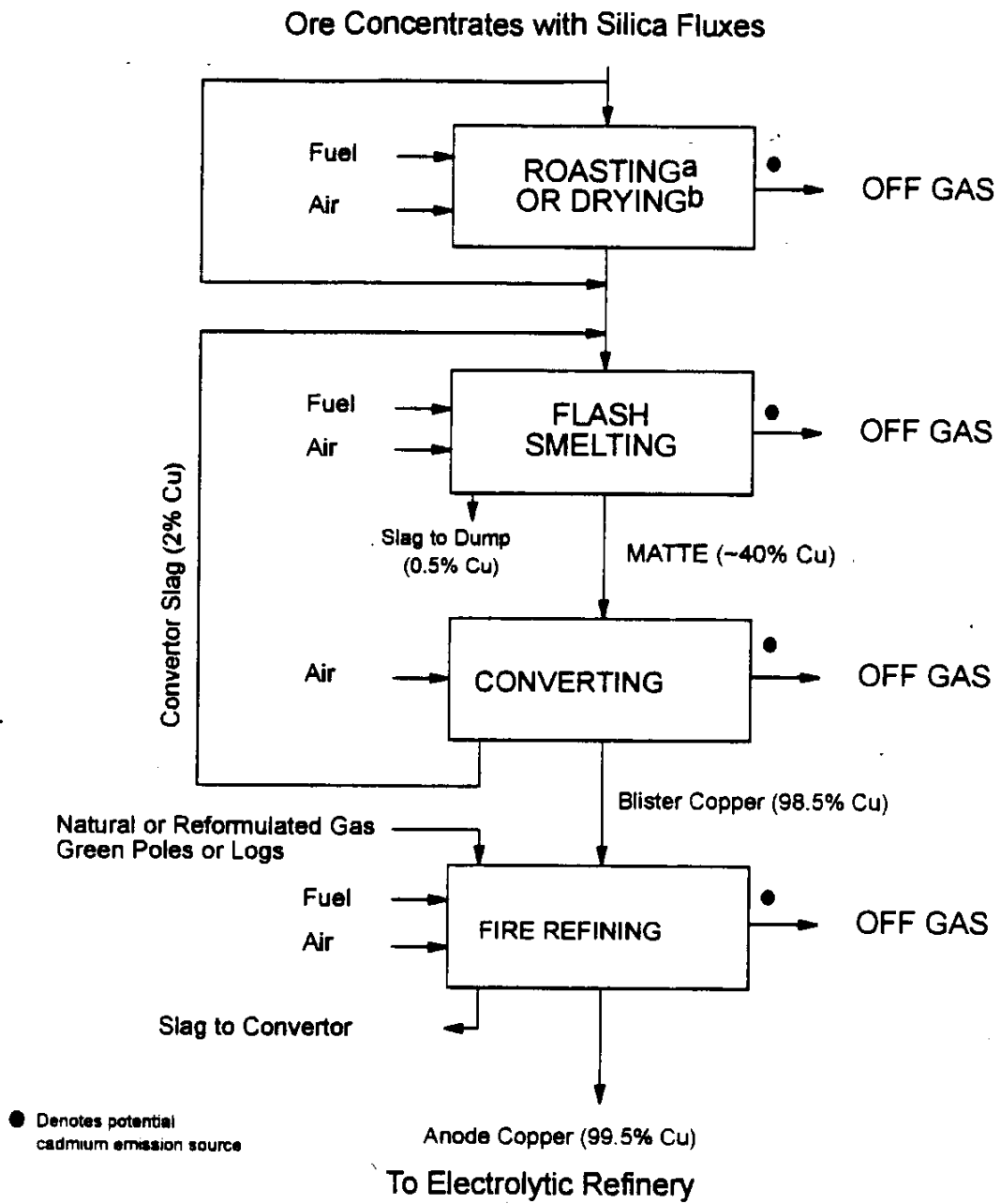

Figure 7-2. Typical primary copper-smelting process.<sup>90</sup>

sulfur as  $\text{SO}_2$ . Portions of such impurities as antimony, arsenic, and lead are driven off, and some iron is converted to oxide. The roasted product, calcine, serves as a dried and heated charge for the smelting furnace. Either multiple-hearth or fluidized-bed roasters are used for roasting copper concentrate. Multiple-hearth roasters accept moist concentrate, whereas fluidized-bed roasters are fed finely ground material (60 percent minus 200 mesh). With both of these types, the roasting is autogenous. Because there is less air dilution, higher  $\text{SO}_2$  concentrations are present in fluidized-bed roaster gases than in multiple-hearth roaster gases. Because cadmium has a boiling point of  $767^\circ\text{C}$  ( $1415^\circ\text{F}$ ), most of the cadmium in the ore may remain in the calcine, instead of being emitted as an air pollutant during roasting.

In the smelting process, either hot calcines from the roaster or raw unroasted concentrates are melted with siliceous flux in a smelting furnace to produce copper matte, a molten mixture of cuprous sulfide ( $\text{Cu}_2\text{S}$ ), ferrous sulfide ( $\text{FeS}$ ) and some heavy metals. The required heat comes from partial oxidation of the sulfide charge and from burning external fuel. Most of the iron and some of the impurities in the charge oxidize with the fluxes to form a slag on top of the molten bath; this slag is periodically removed and discarded. Copper matte remains in the furnace until tapped. Mattes produced by the domestic industry range from 35 to 65 percent copper, with 45 percent being the most common. The copper content percentage is referred to as the matte grade. Currently, five smelting furnace technologies are used in the U.S.: reverberatory, electric, Noranda, Outokumpu (flash), and Inco (flash). Reverberatory furnaces may operate at temperatures as high as  $1500^\circ\text{C}$  ( $2732^\circ\text{F}$ ), while flash furnaces may operate at temperatures of  $1000^\circ\text{F}$  ( $1832^\circ\text{F}$ ). Even though the exact temperatures at which the other two furnace technologies (electric and Noranda) operate are not known, it is probable that

they operate at temperatures higher than the boiling point of cadmium. Therefore, most of the cadmium that remains in the calcine may be emitted as an air pollutant during the smelting step.

Reverberatory furnace operation is a continuous process, with frequent charging of input materials and periodic tapping of matte and skimming of slag. Heat is supplied by combustion of oil, gas or pulverized coal, and furnace temperatures may exceed 1500°C (2732°F).

For smelting in electric arc furnaces, heat is generated by the flow of an electric current in carbon electrodes. These electrodes are lowered through the furnace roof and submerged in the slag layer of the molten bath. The feed generally consists of dried concentrates or calcines; charging wet concentrates is avoided. The chemical and physical changes occurring in the molten bath are similar to those occurring in the molten bath of a reverberatory furnace. Also, the matte and slag-tapping practices are similar at both furnaces. Electric furnaces do not produce fuel combustion gases, so flow rates are lower and SO<sub>2</sub> concentrations are higher in the effluent gas of electric furnaces than in the effluent gas of reverberatory furnaces.

Flash furnace smelting combines the operations of roasting and smelting to produce a high-grade copper matte from concentrates and flux. In flash smelting, dried ore concentrates and finely ground fluxes are injected, together with oxygen, preheated air, or a mixture of both, into a furnace of special design where temperature is maintained at approximately 1000°C (1832°F). In contrast to reverberatory and electric furnaces, flash furnaces use the heat generated from partial oxidation of their sulfide charge to provide much or all of the energy (heat)

required for smelting. They also produce offgas streams containing high concentrations of SO<sub>2</sub>.

Slag produced by flash furnace operations contains significantly higher amounts of copper than is found in reverberatory or electric furnace operations. As a result, the flash furnace and converter slags are treated in a slag-cleaning furnace to recover the copper. Slag-cleaning furnaces usually are small electric furnaces. The flash furnace and converter slags are charged to a slag-cleaning furnace and are allowed to settle under reducing conditions, with the addition of coke or iron sulfide. The copper, which is in the oxide form in the slag, is converted to copper sulfide. The copper sulfide is subsequently removed from the furnace and is charged to a converter with regular matte. If the slag's copper content is low, the slag is discarded.

The Noranda process, as originally designed, allowed the continuous production of blister copper in a single vessel by effectively combining roasting, smelting and converting into one operation. Metallurgical problems, however, led to the operation of these reactors for the production of copper matte. As in flash smelting, the Noranda process takes advantage of the heat energy available from the copper ore. The remaining thermal energy requirement is supplied by oil burners, or by coal mixed with the ore concentrates.

The final step in blister copper production is conversion. This step eliminates the remaining iron and sulfur present in the matte and leaves behind only the molten "blister" copper. All but one U.S. smelter uses Pierce-Smith converters, which are refractory-lined cylindrical steel shells mounted on trunnions at either end, and rotated about the major axis for charging and pouring. An opening in the center of the converter functions as

a mouth through which molten matte, siliceous flux, and scrap copper are charged, and gaseous products are vented. Air or oxygen-rich air is blown through the molten matte. Iron sulfide (FeS) is oxidized to iron oxide (FeO) and SO<sub>2</sub>, and the blowing and slag-skimming steps are repeated until an adequate amount of relatively pure Cu<sub>2</sub>S, called "white metal," accumulates in the bottom of the converter. A renewed air blast then oxidizes the copper sulfide sulfur to SO<sub>2</sub>, leaving blister copper in the converter. The blister copper is subsequently removed and transferred to refining facilities. This segment of converter operation is termed the finish blow. The SO<sub>2</sub> produced throughout the operation is vented to pollution control devices.

One domestic smelter uses Hoboken converters, which has the advantage of emission controls. The Hoboken converter is essentially like a conventional Pierce-Smith converter, except that this vessel is fitted with a side flue at one end, which is shaped as an inverted U. This flue arrangement permits siphoning of gases from the interior of the converter directly into the offgas collection system. This leaves the converter mouth under a slight vacuum.

Blister copper usually contains from 98.5 to 99.5 percent pure copper. Impurities may include gold, silver, antimony, arsenic, bismuth, iron, lead, nickel, selenium, sulfur, tellurium, and zinc. To purify blister copper further, fire refining and electrolytic refining are used. In fire refining, blister copper is placed in a fire-refining furnace; a flux is usually added, and air is blown through the molten mixture to oxidize remaining impurities, which are removed as a slag. The remaining metal bath is subjected to a reducing atmosphere, which reconverts cuprous oxide to copper. The temperature in the furnace is around 1100°C (2012°F). The fire-refined copper is then cast into anodes, and then further electrolytic refining

separates copper from impurities by electrolysis in a solution containing copper sulfate and sulfuric acid. Metallic impurities precipitate from the solution and form a sludge that is removed and treated to recover precious metals. Copper is dissolved from the anode and deposited at the cathode. Cathode copper is remelted and made into bars, ingots or slabs for marketing purpose. The copper produced is 99.95 to 99.97 percent pure. Any residual cadmium that has not been emitted during the smelting step may be emitted during the refining step.

### Emission Control Measures<sup>8</sup>

Cadmium emission sources are indicated in Figure 7-2 by solid circles. Emission controls on copper smelters are used for controlling PM and SO<sub>2</sub> emissions resulting from roasters, smelting furnaces, and convertors. Electrostatic precipitators are the common PM control techniques employed at copper-smelting facilities.

Control of SO<sub>2</sub> emissions is achieved by absorption to sulfuric acid in the sulfuric acid plants, which are commonly part of copper-smelting plants.

### Emissions

Cadmium, which is present in the ore, can potentially be emitted from smelting furnaces and convertors. Table 7-5 presents estimates of cadmium emissions reported by three facilities during 1990<sup>4</sup>.

Test data pertaining to cadmium emissions from primary copper facilities are limited. One emission test report at Copper Range Company, located in White Pine, MI, contains results of metals analysis and was reviewed during this study.<sup>9</sup> This facility operates a reverberatory furnace that is controlled by



TABLE 7-5. PRIMARY COPPER PRODUCERS REPORTING CADMIUM EMISSIONS  
IN THE 1990 TOXICS RELEASE INVENTORY

| Smelter                  | Emissions, kg (lbs) |               |               |
|--------------------------|---------------------|---------------|---------------|
|                          | Nonpoint            | Point         | Total         |
| ASARCO Inc., El Paso, TX | 771 (1,696)         | 3,048 (6,706) | 3,819 (8,402) |
| ASARCO Inc., Hayden, AR  | 113 (249)           | 1,203 (2,647) | 1,316 (2,895) |
| Kennecott, Garfield, UT  | 113 (249)           | 340 (748)     | 453, (997)    |

Note: Cypress Miami Mining Co., Globe, AZ, reported zero cadimium emissions in the 1990 TRI.

Source: Reference 4.

an ESP. The exhaust stream from the convertor (which is uncontrolled) is mixed with the exhaust from the ESP outlet and is routed through the main stack and discharged into the atmosphere. Testing for metals was performed at the main stack after two exhaust streams (from the ESP outlet and the convertor) were mixed. Cadmium emissions were measured for three modes of convertor operation: slag-blow, copper-blow, and convertor idle (no blow) cycles. The cadmium level during the slag-blow cycle was measured to be the highest, corresponding to a cadmium emission rate of 2.3509 lb/hr. Additionally, the plant capacity was reported to be approximately 42 tons/hr of feed, which consists of mill concentrate, limestone, iron pyrites, and recycled material. The actual process rate during the test is not known. Since the feed mix varies from facility to facility, the cadmium emissions measured at Copper Range Co. cannot be used to estimate a general cadmium emission factor that would be valid on an industrywide basis. Additionally, Copper Range Co., is the only facility in the U.S. that operates a reverberatory furnace. All other copper-smelting facilities use flash furnaces which inherently produce less emissions.

The only available emission factor data are from the SPECIATE data base. Table 7-6 presents cadmium emission factors for various emission points at primary copper-smelting facilities as reported in the SPECIATE data base.<sup>5</sup> Because the validity of these emission factors cannot be verified, extreme caution should be exercised when using these factors.

#### PRIMARY ZINC SMELTING AND REFINING

Zinc is found primarily as the sulfide ore, sphalerite (ZnS). Its common coproduct ores are lead and copper. Metal impurities commonly associated with ZnS are cadmium (up to 2 percent) and minor quantities of germanium, gallium, indium, and thallium. Zinc ores typically contain from 3 to 11 percent zinc. Some ores, containing as little as 2 percent, are recovered. Concentration at the mine brings this to 49 to 54 percent zinc, with approximately 31 percent free and uncombined sulfur.<sup>10</sup>

A list of primary zinc smelters currently in operation within the U.S. is given in Table 7-7.<sup>11</sup> Zinc ores are processed into metallic slab zinc by two basic processes. Three of the four domestic U.S. zinc-smelting facilities use the electrolytic process, and one plant uses a pyrometallurgical smelting process, which is typical of the primary nonferrous smelting industry. The plant that uses the pyrometallurgical process provides energy by electric resistance heating. Therefore, in this case, the pyrometallurgical process is referred to as the electrothermic process. A description of the process used to manufacture zinc by the electrolytic and electrothermic processes and a discussion of the emissions resulting from the various operations are presented below.

TABLE 7-6. CADMIUM EMISSIONS FROM PRIMARY COPPER PRODUCTION

| Emission source  | Source classification code (SCC) | Cadmium emission factor <sup>a</sup> |          |
|--|----------------------------------|--------------------------------------|----------|
|  |                                  | lb/ton                               | kg/Mg    |
| Reverberatory smelting furnace after roaster--ESP                            | 30300503                         | 0.005                                | 0.0025   |
| Convertor (all configurations)--ESP  | 30300504                         | 0.0036                               | 0.0018   |
| Fire (furnace) refining--ESP   | 30300505                         | 0.001                                | 0.0005   |
| Ore concentrate dryer--ESP   | 30300506                         | 0.001                                | 0.0005   |
| Reverberatory smelting furnace with ore charging (without roasting)--ESP     | 30300507                         | 0.005                                | 0.0025   |
| Fluidized-bed roaster--ESP   | 30300509                         | 0.0055                               | 0.00275  |
| Electric smelting furnace--ESP   | 30300510                         | 0.01                                 | 0.005    |
| Flash smelting   | 30300512                         | 2.3128                               | 1.1564   |
| Roasting: fugitive emissions--ESP  | 30300513                         | 0.00026                              | 0.00013  |
| Reverberatory furnace: fugitive emissions--ESP                               | 30300514                         | 0.00716                              | 0.00358  |
| Convertor: fugitive emissions  | 30300515                         | 0.02829                              | 0.014145 |
| Anode refining furnace: fugitive emissions--ESP                              | 30300516                         | 0.00005                              | 0.000025 |
| Slag-cleaning furnace: fugitive emissions--ESP                               | 30300517                         | 0.0008                               | 0.0004   |
| Slag-cleaning furnace--ESP   | 30300522                         | 0.001                                | 0.0005   |
| AFT MHR+RF/FBR+EF  | 30300524                         | 0.18                                 | 0.09     |
| Fluidized-bed roaster with reverberatory furnace + convertor--ESP            | 30300525                         | 0.0055                               | 0.00275  |
| Concentrate dryer with electric furnace, cleaning furnace and convertor--ESP | 30300526                         | 0.001                                | 0.0005   |
| Concentrate dryer with flash furnace and convertor--ESP                      | 30300527                         | 0.001                                | 0.0005   |

Source: Reference 5.

<sup>a</sup>All emission factors are reported as found in the SPECIATE data base without rounding off (Reference 5). All emission factors reported above are in the units of lb/ton of concentrated ore.

TABLE 7-7. DOMESTIC PRIMARY ZINC PRODUCERS

| Company                                       | Type of process | 1992 slab zinc production capacity, Mg (tons) |
|---|-----------------|---|
| Big River Zinc Co., Sauget, IL                | Electrolytic    | 82,000 (90,200)                               |
| Jersey Miniers Zinc Co., Clarksville, TN      | Electrolytic    | 98,000 (107,800)                              |
| Zinc Corporation of America, Bartlesville, OK | Electrolytic    | 51,000 (56,100)                               |
| Zinc Corporation of America, Monaca, PA       | Electrothermic  | 123,000 (135,300)                             |

Source: Reference 11.

#### Process Description - Electrolytic<sup>10</sup>

A general diagram of the electrolytic and electrothermic processes is presented in Figure 7-3. Electrolytic processing involves four major steps: roasting, leaching, purification, and electrolysis.

Roasting is a process common to both electrolytic and pyrometallurgical processing. Calcine is produced by the roasting reactions in any one of three different types of roasters: multiple-hearth, suspension, or fluidized-bed. Multiple-hearth roasters are the oldest type used in the United States, while fluidized-bed roasters are the most modern. The primary zinc-roasting reaction occurs between 640° and 1000°C (1184° and 1832°F), depending on the type of roaster used. The reaction is:

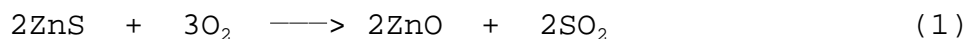

In a multiple-hearth roaster, the concentrate is blown through a series of nine or more hearths stacked inside a brick-

7-19

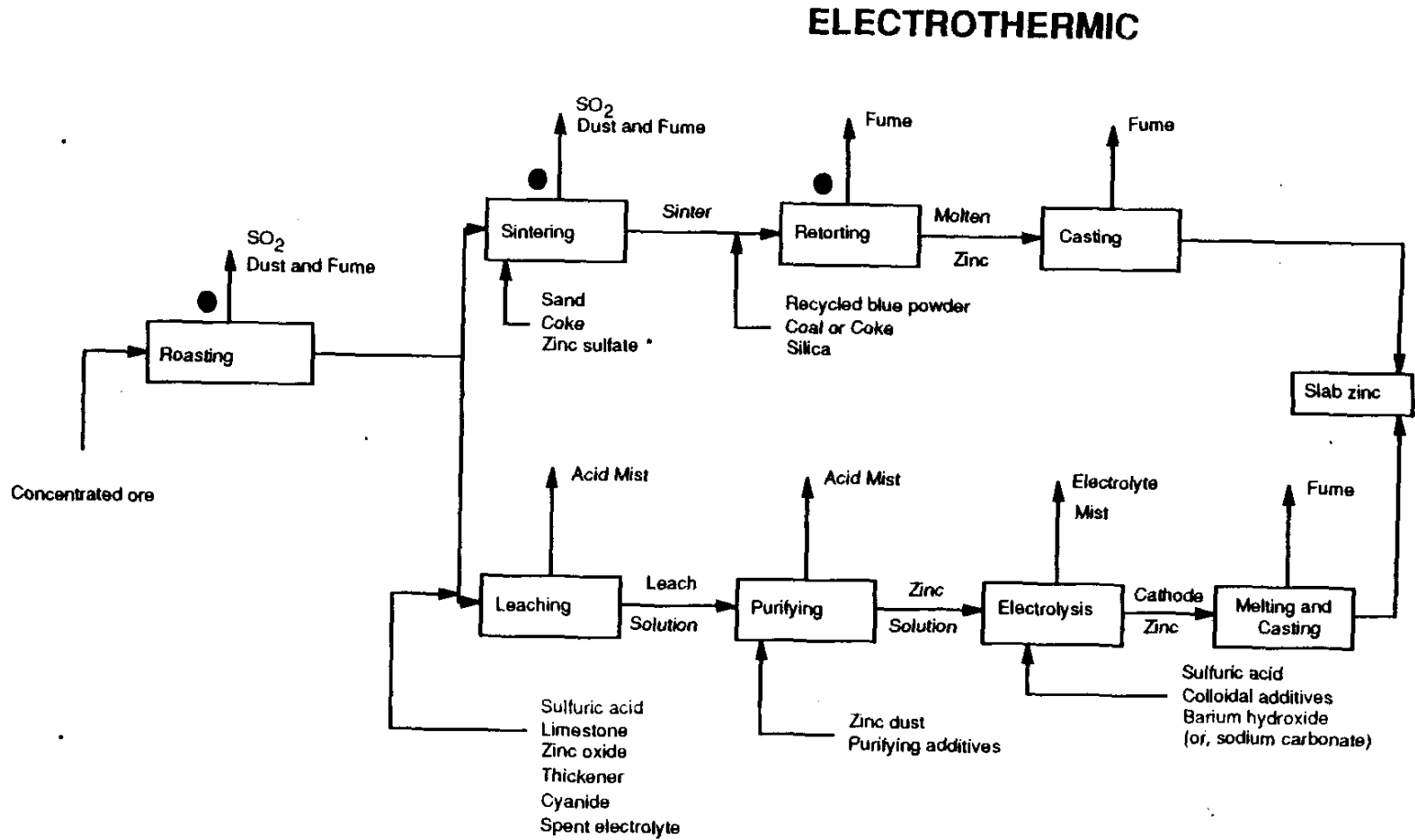

● Denotes potential cadmium emission source

\*The practice of using zinc sulfate solution was discontinued in the late 1970's to lower  $\text{SO}_2$  emissions.

## ELECTROLYTIC

Figure 7-3. Typical primary zinc-smelting process.<sup>90</sup>

lined cylindrical column. As the feed concentrate drops through the furnace, it is first dried by the hot gases passing through the hearths and then oxidized to produce calcine. The reactions are slow and can only be sustained by the addition of fuel.

In a suspension roaster, the feed is blown into a combustion chamber, which is very similar to that of a pulverized coal furnace. Additional grinding, beyond that required for a multiple-hearth furnace, is normally required to assure that heat transfer to the material is fast enough to initiate desulfurization and oxidation reactions in the furnace chamber. Hearths at the bottom of the roaster capture the larger particles, which need more time in the furnace to complete the desulfurization reaction.

In a fluidized-bed roaster, finely ground sulfide concentrates are suspended and oxidized within a pneumatically supported feedstock bed. This technique achieves the lowest sulfur content calcine of the three roaster designs.

Suspension and fluidized-bed roasters are superior to the multiple hearth for several reasons. Although they emit more uncontrolled particulate, their reaction rates are much faster, allowing greater process rates. Also, the SO<sub>2</sub> content of the effluent streams of these two roasters is significantly higher, permitting more efficient and economical use of acid plants to control SO<sub>2</sub> emissions.

Cadmium has a boiling point of approximately 767°C (1413°F). Therefore, most of the cadmium can be expected to be emitted during the roasting step, irrespective of which process is followed.

Leaching is the first step of electrolytic reduction. In this step, the zinc oxide reacts with sulfuric acid to form aqueous zinc sulfate in an electrolyte solution.

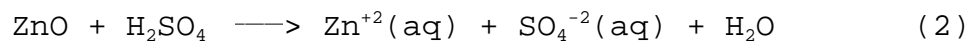

Single and double leach methods can be used, although the former exhibits excessive sulfuric acid losses and poor zinc recovery. In double leaching, the calcine is first leached in a neutral or slightly alkaline solution. The readily soluble sulfates from the calcine dissolve, but only a portion of the zinc oxide enters the solution. The calcine is then leached in the acidic electrolysis recycle electrolyte. The zinc oxide is dissolved as shown in reaction 2, as are many of the impurities, especially iron. The electrolyte is neutralized by this process, and it serves as the leach solution for the first stage of the calcine leaching. This recycling also serves as the first stage of refining, since much of the dissolved iron precipitates out of the solution. Variations on this basic procedure include the use of progressively stronger and hotter acid baths to bring as much of the zinc into solution as possible.

Purification is a process in which a variety of reagents are added to the zinc-laden electrolyte to force impurities to precipitate. The solid precipitates are separated from the solution by filtration. The techniques that are used are among the most advanced industrial applications of inorganic solution chemistry. Processes vary from smelter to smelter, and the details are proprietary and often patented. Metallic impurities, such as arsenic, antimony, cobalt, germanium, nickel, and thallium, interfere severely with the electrolyte deposition of zinc and their final concentrations are limited to less than 0.05 milligrams per liter ( $4 \times 10^{-7}$  pounds per gallon).

Electrolysis takes place in tanks, or cells, containing a number of closely spaced rectangular metal plates, which act as anodes (made of lead with 0.75 to 1.0 percent silver) and as cathodes (made of aluminum). A series of three major reactions occurs within the electrolysis cells:

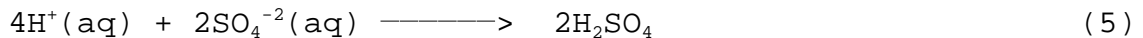
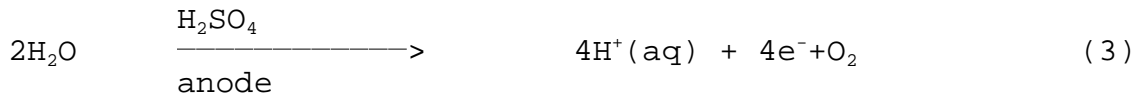

Oxygen gas is released at the anode; metallic zinc is deposited at the cathode, and sulfuric acid is regenerated within the electrolyte.

Electrolytic zinc smelters contain a large number of cells, often several hundred. A portion of the electrical energy released in these cells dissipates as heat. The electrolyte is continuously circulated through cooling towers, both to lower its temperature and to concentrate the electrolyte through the evaporation of water. Periodically, each cell is shut down, and the zinc is removed from the plates.

The final stage of electrolytic zinc smelting is the melting and casting of the cathode zinc into small slabs, 27 kilograms (59 pounds), or large slabs, 640 to 1,100 kilograms (1,408 to 2,420 pounds).



Process Description--Pyrometallurgical (Electrothermic)<sup>10</sup>

Sintering is the first stage of the pyrometallurgical reduction of zinc oxide to slab zinc. Sintering removes lead and cadmium impurities by volatilization and produces an agglomerated permeable mass suitable for feed to retorting furnaces. Downdraft sintering machines of the Dwight-Lloyd type are used in the industry. Grate pallets are joined together for a continuous conveyor system. Combustion air is drawn down through the grate pallets and is exhausted to a particulate control system. The feed is a mixture of calcine, recycled sinter, and coke or coal fuel. Having a low boiling point, oxides of lead and cadmium are volatilized from the sinter bed and are recovered in the particulate control system. As described earlier, most of the cadmium can be expected to be emitted during the roasting step. Any residual cadmium would be emitted during the sintering step.

In retorting, because of the low boiling point of metallic zinc, 906°C (1663°F), reduction and purification of zinc-bearing minerals can be accomplished to a greater extent than with most minerals. The sintered zinc oxide feed is brought into a high temperature reducing atmosphere of 900° to 1499°C (1652° to 2730°F). Under these conditions, the zinc oxide is simultaneously reduced and volatilized to gaseous zinc:

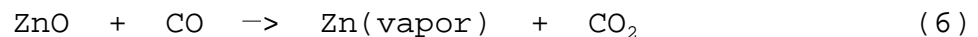

Carbon monoxide regeneration also occurs:



The zinc vapor and carbon monoxide that are produced pass from the main furnace to a condenser where zinc recovery is

accomplished by bubbling the gas mixture through a molten zinc bath.

Retorting furnaces can be heated either externally by combustion flames or internally by electric resistance heating. The latter approach, electrothermic reduction, is the only method currently practiced in the United States, and it has greater thermal efficiency than do external heating methods. In a retort furnace, preheated coke and sinter, silica and miscellaneous zinc-bearing materials are fed continuously into the top of the furnace. Feed coke serves as the principal electrical conductor, producing heat; it also provides the carbon monoxide required for zinc oxide reduction. Further purification steps can be performed on the molten metal collected in the condenser. The molten zinc finally is cast into small slabs, 27 kilograms (59 pounds), or the large slabs, 640 to 1,100 kilograms (1,408 to 2,420 pounds). Any cadmium that is left over from the roasting and sintering steps may be emitted during the retorting step.

#### Emission Control Measures<sup>10,12</sup>

Cadmium emission sources are indicated in Figure 7-3 by solid circles. Emission controls used at electrolytic zinc smelters include fabric filters for controlling PM from ore storage and handling operations, and zinc-smelting operations. Emission controls employed at electrothermic zinc smelters include fabric filters for controlling PM from sinter machines, sinter sizing and crushing operations, electrothermic furnace preheaters, electrothermic furnaces, zinc-holding furnaces, and zinc-refining columns.

Control of SO<sub>2</sub> emissions at both electrolytic and electrothermic zinc smelters is achieved by absorption to

sulfuric acid in the sulfuric acid plants, which are commonly part of zinc-smelting plants.

Emissions

Cadmium, which is present in the ore, can potentially be emitted from roasters (in both electrolytic and electrothermic processes) and from sintering machines and retorting steps of the electrothermic process. Table 7-8 presents estimates of cadmium emissions reported by the four facilities during 1990.<sup>4</sup> The only available emission factor data are from the SPECIATE data base. Table 7-9 presents cadmium emission factors for various emission points at primary zinc-smelting facilities as reported in the SPECIATE data base.<sup>5</sup> Because the validity of these emission factors cannot be verified, extreme caution should be exercised when using them.

TABLE 7-8. PRIMARY ZINC PRODUCERS REPORTING CADMIUM EMISSIONS IN THE 1990 TOXICS RELEASE INVENTORY

| Company                                       | Type of process | Emissions, kg (lb) |
|---|-----------------|--------------------|
| Big River Zinc Co., Sauget, IL                | Electrolytic    | 860 (1,892)        |
| Jersey Miniere Zinc Co., Clarksville, TN      | Electrolytic    | 227 (499)          |
| Zinc Corporation of America, Bartlesville, OK | Electrolytic    | 2,936 (6,459)      |
| Zinc Corporation of America, Monaca, PA       | Electrothermic  | 1,724 (3,793)      |

Source: Reference 4.

TABLE 7-9. CADMIUM EMISSIONS FROM PRIMARY ZINC PRODUCTION

| Emission source                        | Source classification code (SCC) | Cadmium emission factor <sup>a</sup> |          |
|--|----------------------------------|--------------------------------------|----------|
|  |                                  | lb/ton                               | kg/Mg    |
| Multiple-hearth roaster                | 30303002                         | 4.98492 <sup>b</sup>                 | 2.49246  |
| Sinter strand                          | 30303003                         | 1.9764 <sup>b</sup>                  | 0.9882   |
| Vertical retort/electrothermal furnace | 30303005                         | 0.00008 <sup>b</sup>                 | 0.00004  |
| Electrolytic processor                 | 30303006                         | 0.06588 <sup>b</sup>                 | 0.03294  |
| Flash roaster                          | 30303007                         | 43.92 <sup>b</sup>                   | 21.96    |
| Fluidized-bed roaster                  | 30303008                         | 47.5873 <sup>b</sup>                 | 23.79365 |
| Raw material handling and transfer     | 30303009                         | 0.08784 <sup>c</sup>                 | 0.04392  |
| Sinter breaking and cooling            | 30303010                         | 0.03294 <sup>d</sup>                 | 0.01647  |
| Zinc casting                           | 30303011                         | 0.0549 <sup>e</sup>                  | 0.02745  |
| Raw material unloading                 | 30303012                         | 0.00878 <sup>c</sup>                 | 0.00439  |

Source: Reference 5.

<sup>a</sup>All emission factors are reported as found in the SPECIATE data base without rounding off (Reference 5). Emission factors in SPECIATE data base are reported in lb/ton of process activity. It appears that the emission factors reported above are uncontrolled factors.

<sup>b</sup>lb/ton (kg/Mg) of concentrated ore.

<sup>c</sup>lb/ton (kg/Mg) of raw material processed.

<sup>d</sup>lb/ton (kg/Mg) of sinter processed.

<sup>e</sup>lb/ton (kg/Mg) of zinc produced.

## SECONDARY COPPER SMELTING AND REFINING

The secondary copper industry processes scrap metals for the recovery of copper. Products include refined copper or copper alloys in forms such as ingots, wirebar, anodes, and shot. Copper alloys are combinations of copper with other materials,

notably, tin, zinc, and lead. Also, for special applications, combinations include such metals as cobalt, manganese, iron, nickel, cadmium, and beryllium, and nonmetals, such as arsenic and silicon.<sup>13</sup>

A list of secondary copper smelters currently operating within the United States is given in Table 7-10.<sup>7</sup> A description of the process used to manufacture secondary copper and a discussion of the emissions resulting from the various operations are presented below.

TABLE 7-10. DOMESTIC SECONDARY COPPER PRODUCERS

| Smelter  | 1992 Capacity, Mg (tons) |
|--|--------------------------|
| Cerro Copper Products, Sauget, IL              | 70,000 (77,000)          |
| Chemetco (Concorde Metals), Alton, IL          | 135,000 (148,500)        |
| Franklin Smelting & Refining, Philadelphia, PA | 16,000 (17,600)          |
| Gaston Recycling Industries, Gaston, SC        | 110,000 (121,000)        |
| Southwire Co., Carrolton, GA                   | 105,000 (115,500)        |
| Cyprus Casa Grande Corp., Lakeshore, AZ        | 45,000 (49,500)          |

Source: Reference 7.

### Process Description<sup>13</sup>

The principal processes involved in copper recovery are scrap metal pretreatment and smelting. Pretreatment includes cleaning and concentration to prepare the material for the smelting furnace. Smelting involves heating and treating the scrap to achieve separation and purification of specific metals.

The feed material used in the recovery process can be any metallic scrap containing a useful amount of copper, bronze

(copper and tin), or brass (copper and zinc). Traditional forms are punchings; turnings and borings; defective or surplus goods; metallurgical residues such as slags, skimmings, and drosses; and obsolete, worn-out, or damaged articles, including automobile radiators, pipe, wire, bushings, and bearings.

The type and quality of the feed material determines the processes the smelter will use. Due to the large variety of possible feed materials available, the method of operation varies greatly between plants. Generally, a secondary copper facility deals with less pure raw materials and produces a more refined product, whereas brass and bronze alloy processors take cleaner scrap and do less purification and refining. Figure 7-4 is a flowsheet depicting the major processes that can be expected in a secondary copper-smelting operation. A brass and bronze alloying operation is shown in Figure 7-5.

Pretreatment of the feed material can be accomplished using several different procedures, either separately or in combination. Feed scrap is concentrated by manual and mechanical methods, such as sorting, stripping, shredding, and magnetic separation. Feed scrap is sometimes briquetted in a hydraulic press. Pyrometallurgical pretreatment may include sweating, burning of insulation (especially from wire scrap), and drying (burning off oil and volatiles) in rotary kilns. Hydrometallurgical methods include flotation and leaching, with chemical recovery.

In smelting, low-grade scrap is melted in a cupola furnace, producing "black copper" (70 to 80 percent Cu) and slag; these are often separated in a reverberatory furnace. From here, the melt is transferred to a converter or electric furnace to produce "blister" copper, which is 90 to 99 percent Cu. The actual temperature at which the smelting takes place is not

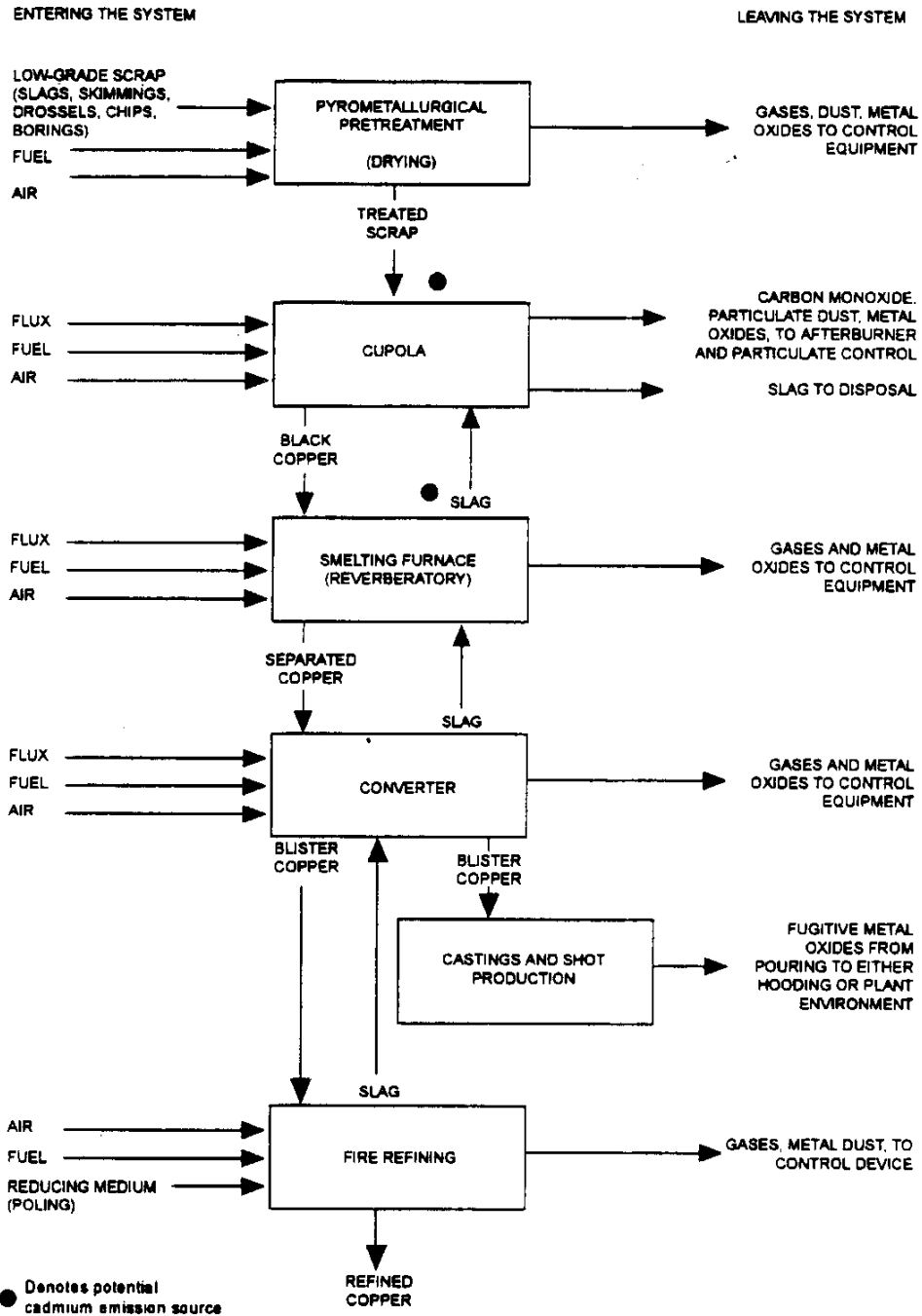

Figure 7-4. Process flow diagram for second-grade copper recovery.<sup>90</sup>

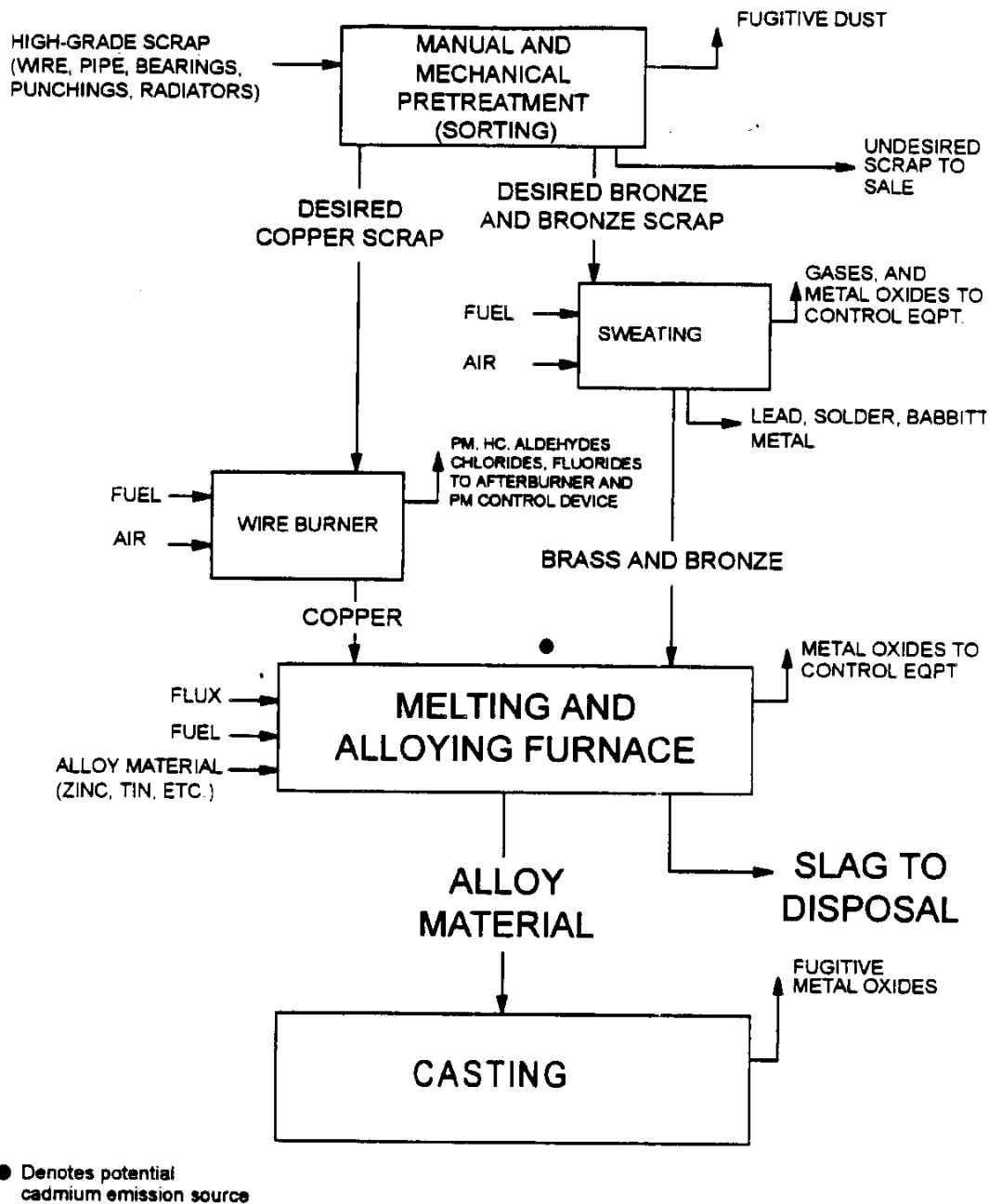

Figure 7-5. Process flow diagram for high-grade brass and bronze alloying.<sup>90</sup>



known. However, it is believed that the operating temperatures are not significantly different from that of primary copper-smelting operations. The temperature in the cupola furnace is believed to exceed the boiling point of cadmium, which is approximately 767°C (1413°F). Therefore, most of the cadmium potentially will be emitted from the cupola furnace.

Blister copper may be poured to produce shot or castings, but is often further refined electrolytically or by fire refining. The fire-refining process is essentially the same as that described for the primary copper-smelting industry. The sequence of events in fire refining is: (1) charging, (2) melting in an oxidizing atmosphere, (3) skimming the slag, (4) blowing with air or oxygen, (5) adding fluxes, (6) "poling" or otherwise providing a reducing atmosphere, (7) reskimming, and (8) pouring.

To produce bronze or brass, rather than copper, an alloying operation is required. Clean, selected bronze and brass scrap is charged to a melting furnace with alloys to bring the resulting mixture to the desired final composition. Fluxes are added to remove impurities and to protect the melt against oxidation by air. Air or oxygen may be blown through the melt to adjust the composition by oxidizing excess zinc.

With zinc-rich feed, such as brass, the zinc oxide concentration in the exhaust gas is sometimes high enough to make recovery for its metal value desirable. This process is accomplished by vaporizing the zinc from the melt at high temperatures and then capturing the oxide downstream in a process fabric filter.

The final step is always casting of the suitably alloyed or refined metal into a desired form, i.e., shot, wirebar, anodes,

cathodes, ingots, or other cast shapes. The metal from the melt is usually poured into a ladle or a small pot (which serves as a surge hopper and a flow regulator) then continues into a mold.

### Emission Control Measures<sup>13</sup>

The principal pollutants emitted from secondary copper-smelting activities are particulate matter in various forms. Removal of insulation from wire by burning causes particulate emissions of metal oxides and unburned insulation. The drying of chips and borings to remove excess oils and cutting fluids can result in large amounts of dense smoke, consisting of soot and unburned hydrocarbons, being discharged. Particulate emissions from the top of a cupola furnace consist of metal oxide fumes, dirt, and dust from limestone and coke.

The smelting process utilizes large volumes of air to oxidize sulfides, zinc, and other undesirable constituents of the feed. This procedure generates considerable particulate matter in the exit gas stream. The wide variation among furnace types, charge types, quality, extent of pretreatment, and size of the charge is reflected in a broad spectrum of particle sizes and variable grain loadings in the escaping gases. One major factor contributing to differences in emission rates is the amount of zinc present in scrap feed materials; the low-boiling zinc evaporates and combines with air oxygen, producing zinc oxide fumes.

Metal oxide fumes from furnaces used in secondary smelters have been controlled by fabric filters, ESP's, or wet scrubbers. Control efficiency by fabric filters may be better than 99 percent, but cooling systems are needed to prevent the hot exhaust gases from damaging or destroying the bag filters. A two-stage system using both water jacketing and radiant cooling

is common. Electrostatic precipitators are not as well suited to this application, having a low-collection efficiency for dense particulates, such as oxides of lead and zinc. Wet scrubber installations also are relatively ineffective in the secondary copper industry. Scrubbers are useful, mainly for particles larger than 1 micron, but the metal oxide fumes generated are generally submicron in size.

Particulate emissions associated with drying kilns can be similarly controlled. Drying temperatures up to 150°C (302°F) produce relatively cool exhaust gases, requiring no precooling for control by fabric filters.

Wire burning generates large amounts of particulate matter, largely unburned combustibles. These emissions can be effectively controlled by direct-flame afterburners, with an efficiency of 90 percent or better if the afterburner combustion temperature is maintained above 1000°C (1832°F). If the insulation contains chlorinated organics, such as polyvinyl chloride, hydrogen chloride gas will be generated and will not be controlled by the afterburner.

One source of fugitive emissions in secondary smelter operations is charging of scrap into furnaces containing molten metals. This often occurs when the scrap being processed is not sufficiently compacted to allow a full charge to fit into the furnace prior to heating. The introduction of additional material onto the liquid metal surface produces significant amounts of volatile and combustible materials and smoke, which can escape through the charging door. Briquetting the charge offers a way to avoid fractional charges. When fractional charging cannot be eliminated, fugitive emissions are reduced by turning off the furnace burners during charging. This reduces

the flow of exhaust gases and enhances the ability of the exhaust control system to handle the emissions.

Metal oxide fumes are generated not only during melting, but also during pouring of the molten metal into the molds. Other dusts may be generated by the charcoal, or other lining, used in association with the mold. Covering the metal surface with ground charcoal is a method used to make "smooth-top" ingots. This process creates a shower or sparks, releasing emissions into the plant near the furnace top and the molds being filled.

### Emissions

Cadmium may be expected to be present in the scrap metals that are processed to recover secondary copper. Therefore, cadmium emissions can be expected from secondary copper-smelting operations. Table 7-11 presents estimates of cadmium emissions reported by four facilities during 1989 and 1990 as required under SARA Title III regulations.<sup>4,14</sup> However, no test data are available pertaining to cadmium emissions from secondary copper-smelting operations. The only available emission factor data are from the SPECIATE data base. These data show the cadmium emission factor for electric induction furnace at secondary copper-smelting facilities to be 0.0012 kg/Mg (0.0024 lb/ton) of material charged into the furnace.<sup>15</sup> Because the validity of these emission factors cannot be verified, extreme caution should be exercised when using them.

TABLE 7-11. SECONDARY COPPER PRODUCERS REPORTING CADMIUM EMISSIONS IN THE 1989 AND 1990 TOXICS RELEASE INVENTORY

| Company                            | Location         | Emissions, kg(lb)        |
|------------------------------------|------------------|--------------------------|
| Southwire Co.                      | Carrolton, GA    | 57 (125) <sup>a</sup>    |
| Franklin Smelting & Refining       | Philadelphia, PA | 454 (1,000) <sup>b</sup> |
| Gaston Copper Recycling Industries | Gaston, SC       | 4.5 (10) <sup>b</sup>    |
| Chemetco                           | Sauget, IL       | 680 (1,496) <sup>b</sup> |

SOURCE: References 4 and 14

<sup>a</sup>The emission rate reported is for 1989.

<sup>b</sup>The emission rate reported is for 1990.

#### SECONDARY ZINC RECOVERY FROM METALLIC SCRAP

The secondary zinc industry processes obsolete and scrap materials to recover zinc as slabs, dust, and zinc oxide.<sup>15</sup> Table 7-12 presents a list of U.S. facilities where zinc currently is recovered from metal scrap. Cadmium can be expected to be present in the metallic scrap that is processed to recover zinc, and therefore be emitted as an air pollutant during different processing steps. A description of the process used to manufacture zinc from metallic scrap is presented below.

#### Process Description<sup>15</sup>

Processing involves three operations: scrap pretreatment, melting, and refining. Processes typically used in each operation are shown in Figure 7-6. Molten product zinc may be used in zinc galvanizing.

#### Scrap Pretreatment--

Pretreatment is the partial removal of metal and other contaminants from scrap containing zinc. Sweating separates zinc from high-melting metals and contaminants by melting the zinc in

TABLE 7-12. DOMESTIC PRODUCERS OF SECONDARY ZINC  
FROM METALLIC SCRAP

| Smelter                          | Location             | 1990 Production capacity, Mg (tons) |
|----------------------------------|----------------------|-------------------------------------|
| Arco Alloys, Inc.                | Detroit, MI          | See footnote a                      |
| W.J. Bullock, Inc.               | Fairfield, AL        | See footnote a                      |
| T.L. Diamond & Co., Inc.         | Spelter, WV          | See footnote a                      |
| Florida Steel Co.                | Jackson, TN          | See footnote a                      |
| Gulf Reduction Corp.             | Houston, TX          | See footnote a                      |
| Hugo Neu-Proler Co.              | Terminal Island, CA  | See footnote a                      |
| Huron Valley Steel Corp.         | Belleville, MI       | See footnote a                      |
| Indiana Steel & Wire Co., Inc.   | Muncie, IN           | See footnote a                      |
| Interamerican Zinc Inc.          | Adrian, MI           | See footnote a                      |
| New England Smelting Works, Inc. | West Springfield, MA | See footnote a                      |
| Nucor Yamato Steel Co.           | Blytheville, AR      | See footnote a                      |
| The River Smelting & RFG Co.     | Cleveland, OH        | See footnote a                      |
| Zinc Corp. of America            | Palmerton, PA        | See footnote a                      |

Source: Reference 11.

<sup>a</sup>The total zinc production capacity for all 13 plants is 58,000 Mg (63,800 tons).  
Individual capacity data are not available.

7-37

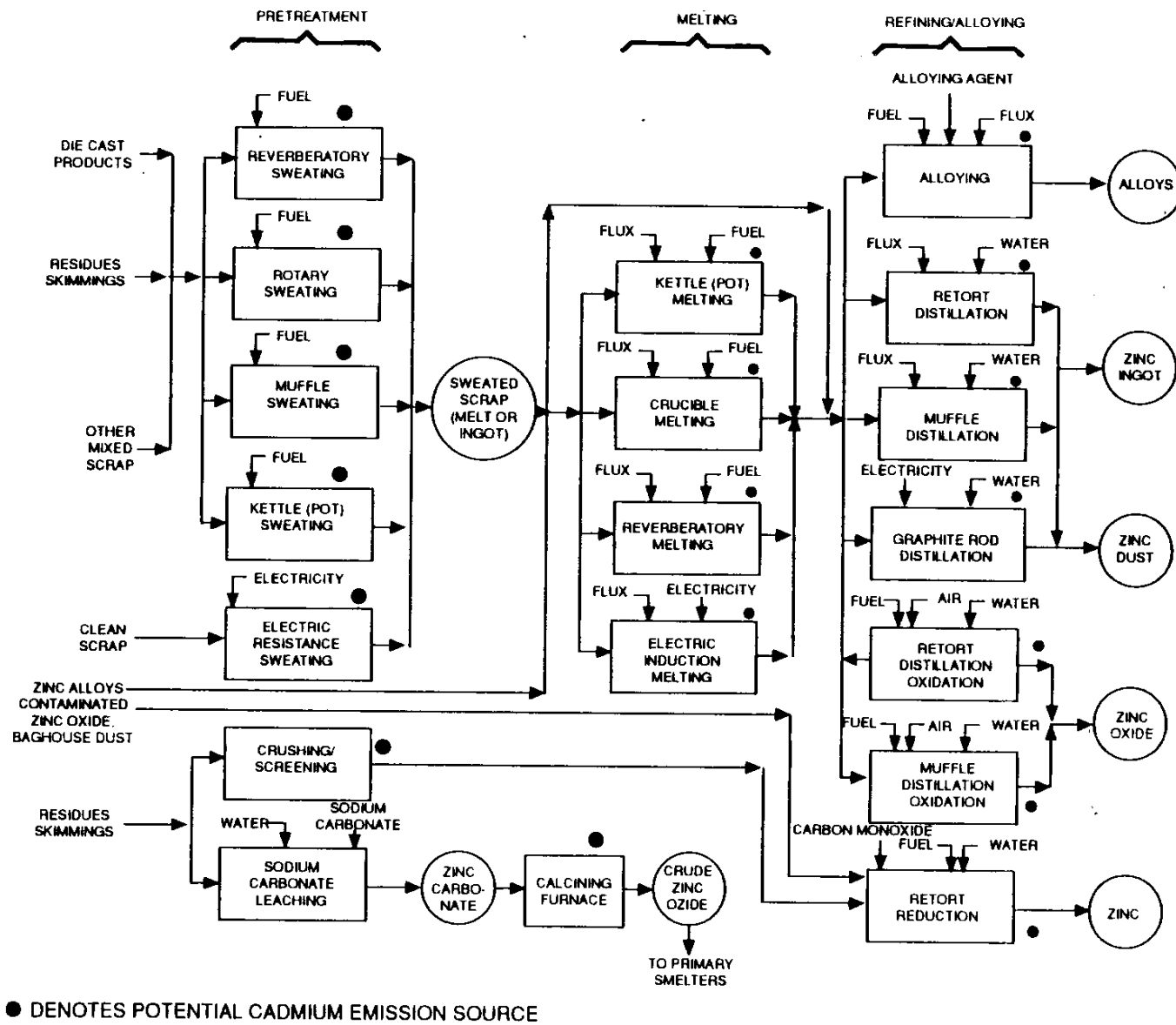

Figure 7-6. Process flow diagram for secondary zinc processing. 90

kettle, rotary, reverberatory, muffle or electric resistance furnaces. Usually, the product zinc then is directly used in melting, refining or alloying processes. The high-melting residue is periodically raked from the furnace and further processed to recover zinc. These residues may be processed by crushing/screening to recover impure zinc or by sodium carbonate leaching to produce zinc oxide. The temperature at which the pretreatment takes place may be highly variable, depending on the type of scrap. It is believed that the temperature at which the pretreatment takes place may be comparable to that of primary zinc operations. Therefore, the pretreatment step may result in cadmium emissions.

In crushing/screening, zinc-bearing residues are pulverized or crushed to break the physical bonds between metallic zinc and contaminants. The impure zinc is then separated in a screening or pneumatic classification step.

In sodium carbonate leaching, the zinc-bearing residues are converted to zinc oxide, which can be reduced to zinc metal. They are crushed and washed to leach out zinc from contaminants. The aqueous stream is then treated with sodium carbonate, precipitating zinc as the hydroxide or carbonate. The precipitate is then dried and calcined to convert zinc hydroxide into crude zinc oxide. The ZnO product is usually refined to zinc at primary zinc smelters.

#### Melting--

Zinc is melted at 425-590°C (797-1094°F) in kettle, crucible, reverberatory, and electric induction furnaces. Zinc to be melted may be in the form of ingots, reject castings, flashing or scrap. Ingots, rejects, and heavy scrap are generally melted first to provide a molten bath to which light scrap and flashing are added. Before pouring, a flux is added



and the batch agitated to separate the dross that accumulates during the melting operation. The flux floats the dross and conditions it so it can be skimmed from the surface. After skimming, the melt can be poured into molds or ladles. Any residual cadmium left over from the pretreatment step may not be emitted during the melting stage because the melting takes place at a much lower temperature than the boiling point of cadmium.

#### Refining/Alloying--

Additional processing steps may involve alloying, distillation, distillation and oxidation, or reduction. Alloying produces mainly zinc alloys from pretreated scrap. Often the alloying operation is combined with sweating or melting.

Distillation retorts and furnaces are used to reclaim zinc from alloys or to refine crude zinc. Retort distillation is the vaporization at 980-1250°C (1796-2282°F) of elemental zinc with its subsequent condensation as zinc dust or liquid zinc. Rapid cooling of the vapor stream below the zinc melting point produces zinc dust, which can be removed from the condenser and packaged. If slab zinc is the desired product, the vapors are condensed slowly at a higher temperature. The resultant melt is cast into ingots or slabs. Muffle distillation furnaces produce principally zinc ingots, and graphite rod resistance distillation produces zinc dust. Because the distillation takes place at temperatures higher than the boiling point of cadmium (767°C [1413°F]), cadmium may potentially be emitted during the distillation step.

Retort and muffle furnace distillation and oxidation processes produce zinc oxide dust. These processes are similar to distillation through the vaporization step. In contrast, for distillation/oxidation, the condenser is omitted, and the zinc vapor is discharged directly into an air stream leading to a

refractory-lined combustion chamber. Excess air is added to complete oxidation and to cool the product. The zinc oxide product is usually collected in a fabric filter.

In retort reduction, zinc metal is produced by the reaction of carbon monoxide and zinc oxide to yield zinc and carbon dioxide. Carbon monoxide is supplied by the partial oxidation of the coke. The zinc is recovered by condensation.

#### Zinc Galvanizing--

Zinc galvanizing is the coating of clean oxide free iron or steel with a thin layer of zinc by immersion in molten zinc. The galvanizing occurs in a vat or in dip tanks containing molten zinc and cover flux.

#### Emission Control Measures<sup>15</sup>

Emissions from seating and melting operations consist principally of particulates, zinc fumes, other volatile metals, flux fumes, and smoke generated by the incomplete combustion of grease, rubber and plastics in the zinc-bearing feed material. Zinc fumes are negligible at low furnace temperatures, for they have a low vapor pressure even at 480°C (896°F). With elevated temperatures, however, heavy fuming can result. Flux emissions are minimized by the use of a nonfuming flux. Substantial emissions may arise from incomplete combustion of carbonaceous material in the zinc scrap. These contaminants are usually controlled by afterburners. Further emissions are the products of combustion of the furnace fuel. Since the furnace fuel is usually natural gas, these emissions are minor. In reverberatory furnaces, the products of fuel combustion are emitted with the other emissions. Other furnaces emit the fuel combustion products as a separate emission stream.

Particulates from sweating and melting are mainly hydrated zinc chloride ( $\text{ZnCl}_2$ ) and  $\text{ZnO}$ , with small amounts of carbonaceous material. These particulates also contain Cu, Cd, manganese (Mn), and chromium (Cr).

Fabric filters are most commonly used to recover particulate emissions from sweating and melting. In one application on a muffle-sweating furnace, a cyclone and fabric filter achieved particulate recovery efficiencies in excess of 99.7 percent. In another application on a reverberatory sweating furnace, a fabric filter removed 96.3 percent of the particulates, reducing the dust loading from  $0.513 \text{ g/Nm}^3$  to  $0.02 \text{ g/Nm}^3$ . Fabric filters show similar efficiencies in removing particulates from exhaust gases of melting furnaces.

Crushing and screening operations also are sources of dust emissions. These particulates are composed of Zn, Al, Cu, Fe, lead (Pb), Cd, tin (Sn), and Cr, and they can be recovered from hooded exhausts by fabric filters.

The sodium carbonate leaching process produces particulate emissions of  $\text{ZnO}$  dust during the calcining operation. This dust can be recovered in fabric filters, although  $\text{ZnCl}_2$  in the dust may cause plugging problems.

Emissions from refining operations are mainly metallic fumes. These fume and dust particles are quite small, with sizes ranging from  $0.05\text{-}1 \mu$ . Distillation/oxidation operations emit their entire  $\text{ZnO}$  product in the exhaust gas. The  $\text{ZnO}$  has a very small particle size ( $0.03$  to  $0.5 \mu$ ) and is recovered in fabric filters with typical collection efficiencies of 98 to 99 percent.

Some emissions of zinc oxide occur during galvanizing, but these emissions are small because of the bath flux cover and the relatively low temperature maintained in the bath.

### Emissions

Cadmium may be expected to be present in the scrap metals that are processed to recover zinc. Therefore, cadmium emissions can be expected from secondary zinc recovery operations. One secondary smelter reported a cadmium emission rate of 588 lb/yr during the year 1989.<sup>14</sup> However, no test data are available pertaining to cadmium emissions from secondary zinc recovery operations. The only available emission factor data are from the SPECIATE data base. Table 7-13 presents cadmium emission factors for various emission points at secondary zinc-smelting facilities as reported in the SPECIATE data base.<sup>5</sup> Because the validity of these emission factors cannot be verified, extreme caution should be exercised when using them.

### SECONDARY ZINC RECOVERY FROM STEEL PRODUCTION

Zinc also is recovered from electric arc furnace (EAF) dust generated at iron and steel manufacturing facilities. A study carried out in May 1985 by the Center for Metals Production estimated that approximately 14.5 percent of EAF dust is processed for zinc recovery. One data source has reported that cadmium content in the EAF dust is approximately 0.05 percent. Thus, cadmium can potentially be emitted during the process of recovering zinc from EAF dust.<sup>16</sup>

Table 7-14 contains a list of facilities in the U.S. that are capable of producing EAF dust.<sup>11</sup> Of these facilities, only two actually recover zinc.<sup>17</sup> A description of the processes used to recover zinc from EAF dust is presented below.

TABLE 7-13. CADMIUM EMISSIONS FROM SECONDARY ZINC RECOVERY FROM METAL SCRAP

| Emission source                                      | Source classification code (SCC) | Cadmium emission factor <sup>a</sup> |          |
|--|----------------------------------|--------------------------------------|----------|
|  |                                  | lb/ton                               | kg/Mg    |
| Retort furnace                                       | 30400801                         | 0.03619 <sup>b</sup>                 | 0.018095 |
| Horizontal muffle furnace                            | 30400802                         |                                      | 0.017325 |
| Pot furnace  | 30400803                         | 0.03465 <sup>b</sup>                 | 0.00004  |
| Galvanizing kettle                                   | 30400805                         | 0.00008 <sup>b</sup>                 | 0.001925 |
| Calcining kiln                                       | 30400806                         | 0.00385 <sup>c</sup>                 | 0.034265 |
|  |                                  | 0.06853 <sup>b</sup>                 |          |
| Rotary-sweat furnace                                 | 30400809                         | 0.01386 <sup>b</sup>                 | 0.00693  |
| Muffle-sweat furnace                                 | 30400810                         |                                      | 0.00824  |
| Electric resistance sweat furnace                    | 30400811                         | 0.01648 <sup>b</sup>                 | 0.00385  |
| Crushing/screening of zinc residues                  | 30400812                         | 0.0077 <sup>b</sup>                  | 0.001635 |
| Kettle-sweat furnace (general metallic scrap)        | 30400824                         | 0.00327 <sup>d</sup>                 | 0.004235 |
|  |                                  | 0.00847 <sup>b</sup>                 |          |
| Reverberatory sweat furnace (general metallic scrap) | 30400828                         | 0.01001 <sup>b</sup>                 | 0.005005 |
| Kettle-sweat furnace (general metallic scrap)        | 30400834                         |                                      | 0.009625 |
| Reverberatory sweat furnace (general metallic scrap) | 30400838                         | 0.01925 <sup>b</sup>                 | 0.01232  |
| Retort and muffle distillation: Pouring              | 30400851                         | 0.02464 <sup>b</sup>                 | 0.00023  |
| Retort and muffle distillation: Casting              | 30400852                         | 0.00046 <sup>b</sup>                 | 0.000115 |
|  |                                  | 0.00023 <sup>b</sup>                 |          |
| Retort distillation/oxidation                        | 30400854                         | 0.0231 <sup>e</sup>                  | 0.01155  |
| Muffle distillation/oxidation                        | 30400855                         |                                      | 0.01155  |
| Rotary sweating                                      | 30400862                         | 0.0231 <sup>e</sup>                  | 0.000345 |
| Muffle sweating                                      | 30400863                         | 0.00069 <sup>b</sup>                 | 0.00041  |
| Kettle (pot) sweating                                | 30400864                         | 0.00082 <sup>b</sup>                 | 0.000215 |
|  |                                  | 0.00043 <sup>c</sup>                 |          |
| Electric resistance sweating                         | 30400865                         | 0.00039 <sup>f</sup>                 | 0.000195 |
| Retort and muffle distillation                       | 30400872                         |                                      | 0.00091  |
| Casting  | 30400873                         | 0.00182 <sup>b</sup>                 | 0.000005 |
|  |                                  | 0.00001 <sup>b</sup>                 |          |

Source: Reference 5.

<sup>a</sup>All emission factors are reported as found in the SPECIATE data base without rounding off (Reference 5). Emission factors in SPECIATE data base are reported in lb/ton of process activity. It appears that the emission factors reported above are uncontrolled factors.

<sup>b</sup>lb/ton (kg/Mg) of zinc produced.

<sup>c</sup>lb/ton (kg/Mg) of zinc used.

<sup>d</sup>lb/ton (kg/Mg) of residue.

<sup>e</sup>lb/ton (kg/Mg) of zinc oxide produced.

<sup>f</sup>lb/ton (kg/Mg) of scrap processed.

TABLE 7-14. DOMESTIC PRODUCERS OF SECONDARY ZINC FROM EAF DUST

| Company                                  | Location         | EAF processing capacity, Mg (tons) | Zinc recovering capacity, Mg (tons) <sup>a</sup> |
|--|------------------|------------------------------------|--|
| Florida Steel Co.                        | Jackson, TN      | 7,200 (7,920)                      | 1,400 (1,540)                                    |
| Horsehead Development Resource Co., Inc. | Calumet City, IL | 72,000 (79,200)                    | 75,000 (82,500) <sup>b</sup>                     |
| Horsehead Development Resource Co., Inc. | Monaca, PA       | 18,000 (19,800)                    | See footnote b                                   |
| Horsehead Development Resource Co., Inc. | Palmerton, PA    | 245,000 (269,500)                  | See footnote b                                   |
| Horsehead Development Resource Co., Inc. | Rockwood, TN     | 90,000 (99,000)                    | See footnote b                                   |
| Laclede Steel Co.                        | St. Louis, MO    | 36,000 (39,600)                    | 6,000 (6,600)                                    |
| North Star Steel Corp.                   | Beaumont, TX     | 27,000 (29,700)                    | 5,000 (5,500)                                    |
| Nucor-Yamamoto Steel Co.                 | Blytheville, AR  | 11,000 (12,100)                    | 1,800 (1,980)                                    |
| Zia Technology of Texas Inc.             | Caldwell, TX     | 27,000 (29,700)                    | 4,500 (4,950)                                    |

Source: Reference 11.

<sup>a</sup>Even though there are nine facilities, which have the capability to process EAF, only two facilities, Florida Steel and Nucor-Yamamoto Steel Co., actually recover zinc from EAF dust.<sup>17</sup>

<sup>b</sup>The combined zinc capacity for all four locations of Horsehead Development Co., is 75,000 Mg (82,500 tons). Data pertaining to individual capacities are not available.

## Process Description<sup>16,18</sup>

The process of recovering zinc from EAF dust is carried out in two steps. In the first step, nonferrous ingredients are volatilized from the EAF dust. The second step consists of processing the volatilized nonferrous ingredients in a rotary furnace (calcining kiln) to produce a zinc oxide calcine.

Two processes are available to carry out the first step of volatilizing nonferrous components from EAF dust. These are the Waelz kiln and flame reactor processes.

Waelz kiln process--

Figure 7-7 presents a typical process flow diagram for the Waelz kiln process. In this process, EAF dust is fed along with anthracite coal and silica fluxes into a rotary kiln. The kiln contains two reaction zones: the solid material charge zone and the gaseous zone above the solid zone. Coal in the solid zone combusts to form carbon monoxide (CO) which reduces the metal oxides, thus volatilizing the metals. Nonferrous metals volatilize when the temperature in the kiln reaches 1000°C (1832°F). When the nonferrous metals reach the gaseous zone upon volatilization, they are again oxidized to form corresponding metal oxides. The above processes are described by the following chemical reactions that take place in the kiln:

### Combustion reactions

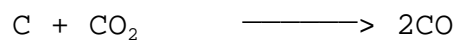

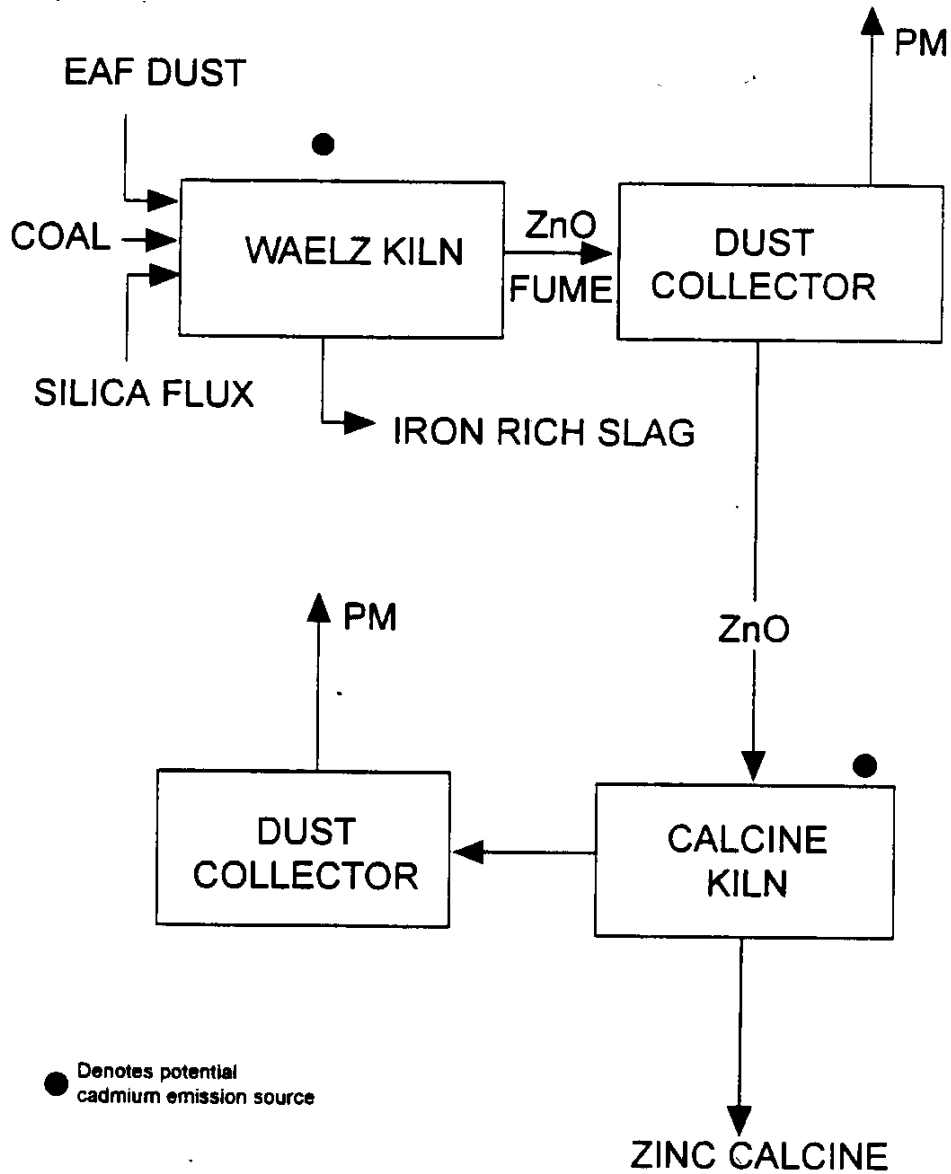
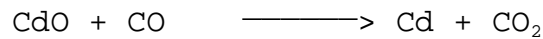
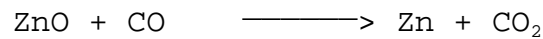
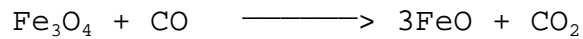

Figure 7-7. Process flow diagram for Waelz kiln process.<sup>98</sup>



### Reduction reactions



### Oxidation reactions

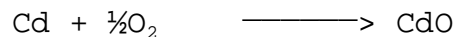
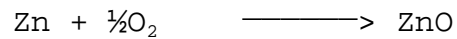
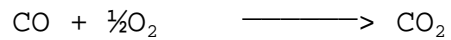

### ZnO Calcine Formation--

The nonferrous metal oxide product formed by ZnO calcine formation is captured in a fabric filter and subsequently processed in a natural gas-fired calcining kiln to form zinc calcine. Figure 7-7 also presents a typical process flow diagram for the calcining kiln operation. In the calcining kiln, the nonferrous metal oxides are introduced without any additives, and selective volatilization is carried out to separate cadmium, lead, chlorine, and fluorine. The volatilized material is collected in a fabric filter. Zinc originally present in the form of ZnO is recovered unaltered as residue from the calcining kiln. The ZnO can subsequently be processed by electrothermic process to recover zinc.

### Flame Reactor Process--

Figure 7-8 presents a flow diagram for the flame reactor process used to volatilize nonferrous metals from dust. This process is an alternative method for the Waelz kiln process. In the flame reactor process, EAF dust is fed into a water-cooled, natural gas-fired reactor. The combustion air is enriched with oxygen raising the oxygen content to a level between 40 and 80 percent. Flame temperatures up to 2200°C (3992°F) can be obtained this way. As the EAF dust is introduced into the hot

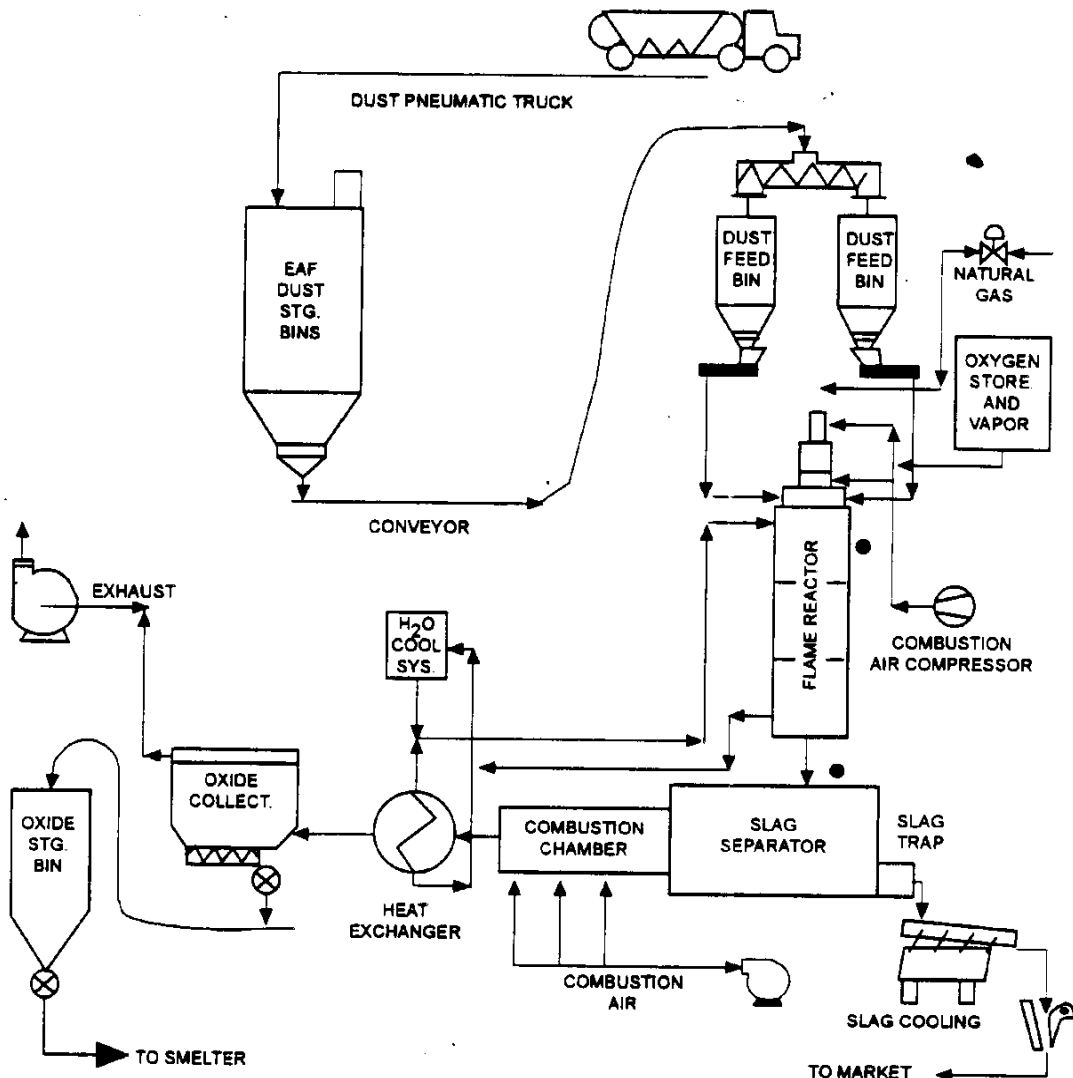

● DENOTES POTENTIAL CADMIUM EMISSION SOURCE

Figure 7-8. Process flow diagram for zinc calcine formation.<sup>98</sup>

gases and temperatures reach 1600°C (2912°F), refractory compounds present in the dust fuse to form molten slag. The molten slag and the combustion gases are conveyed into a slag convertor where iron-rich slag is continuously tapped. The offgases exiting the separator are oxidized further to form metallic (nonferrous) oxides, which are recovered in a fabric filter and shipped as feedstock to zinc-smelting facilities.

#### Emission Control Measures<sup>16,18</sup>

Emissions resulting from processing of EAF dust chiefly consist of particulate matter made up of nonferrous metallic oxides (including cadmium oxide), which are recovered in a fabric filter. The fabric filter is used more as a product recovery device than a control device.

#### Emissions<sup>18</sup>

Data pertaining to cadmium emissions from EAF dust processing are limited. One source has reported a cadmium emission rate of  $5.04 \times 10^{-4}$  lb/hr measured at the outlet of a fabric filter servicing a flame reactor, which corresponds to a EAF dust processing rate of 40 lb/min (1.2 tons/hr). This results in a cadmium emission factor of  $2.1 \times 10^{-4}$  kg/Mg ( $4.2 \times 10^{-4}$  lb/ton) of EAF dust processed. No other details pertaining to the test are available. Therefore, the validity of this cadmium emission factor cannot be verified. The cadmium emission factor must be used with extreme caution.

## REFERENCES

1. Emission Standards Division. Cadmium Emissions from Primary Lead and Primary Copper Smelting--Phase I Technical Report. EPA-450/3-88-006. Office of Air Quality Planning and Standards, U.S. Environmental Protection Agency, Research Triangle Park, NC. June 1988. p. 5.
2. Woodbury, W.D. Lead--Annual Report 1990. Bureau of Mines, U.S. Department of the Interior, U.S. Government Printing Office, Washington, DC. April 1992.
3. Compilation of Air Pollution Emission Factors, Volume I: Stationary Point and Area Sources (AP-42), Fourth Edition. U. S. Environmental Protection Agency. Research Triangle Park, NC. Pp. 7.6-1 - 7.6-15.
4. U. S. Environmental Protection Agency. 1990 Toxic Chemical Release Inventory. Office of Toxic Substances, Washington, DC., January 1993.
5. SPECIATE. Volatile Organic Compound (VOC)/Particulate Matter (PM) Speciation Data System, Version 1.4. Office of Air and Radiation. Office of Air Quality Planning and Standards, U.S. Environmental Protection Agency, Research Triangle Park, NC. October 1991.
6. Reference 1, p. 9.
7. Telefax from Jolly, J. Bureau of Mines, U.S. Department of the Interior, Washington, DC. January 23, 1993. Capacities of U.S. copper smelters.
8. Reference 5, Pp. 7.3-1 - 7.3-18.
9. TRC Environmental Corporation. Emission Characterization Program. Prepared for Copper Range Company, White Pine, Michigan. October 15, 1992.
10. Reference 3, Pp. 7.7-1 - 7.7-8.
11. Telefax from Jolly, J. Bureau of Mines, U.S. Department of the Interior, Washington, DC. February 10, 1993. Capacities of U.S. zinc smelters.
12. Zinc/Zinc Oxide Preliminary Source Assessment. EPA-450/3-87-008. Office of Air Quality Planning and Standards, U.S. Environmental Protection Agency, Research Triangle Park, NC. April 1987. Pp. 1-10-1-11.

13. Reference 3, Pp. 7.9-1 - 7.9-6.
14. U. S. Environmental Protection Agency. 1989 Toxic Chemical Release Inventory. Office of Toxic Substances, Washington, DC. January 1993.
15. Reference 3. Pp. 7.14-1 - 7.14-8.
16. James, S. E., and C. O. Bounds. Recycling Lead and Cadmium, As Well As Zinc, from EAF Dust. (In) Lead-Zinc, '90, Proc. World Symp. Metall. Environ. Control 119<sup>th</sup> TMS Annu. Meet. T. S. Mackey and R. D. Prengaman, eds. Miner. Met. Mater. Soc., Warrendale, PA. 1990. Pp. 477-495.
17. Telecon. Kalagnanam, R.S., Midwest Research Institute, with J.H. Jolly. Bureau of Mines, U.S. Department of the Interior. February 10, 1993. U.S. processors of EAF dust.
18. Bounds, C. O., and J. F. Pusateri. EAF Dust Processing in the Gas-Fired Flame Reactor Process. (In) Lead-Zinc, '90, Proc. World Symp. Metall. Environ. Control 119<sup>th</sup> TMS Annu. Meet. T. S. Mackey and R. D. Prengaman, eds. Miner. Met. Mater. Soc., Warrendale, PA. 1990. Pp. 511-528.

## SECTION 8

### EMISSIONS FROM MISCELLANEOUS SOURCES

Cadmium is present in minerals, ores, and crudes extracted from the earth and these materials are used in several manufacturing processes. These manufacturing processes can be potential cadmium emission sources if they use cadmium containing materials in thermal treatment steps. The manufacturing processes described in this section are: iron and steel production, Portland cement manufacture, phosphate rock processing, carbon black production, and mobile sources. This section presents process information and emission control measures, and estimates of cadmium emissions from each of these sources.

#### IRON AND STEEL PRODUCTION<sup>1</sup>

Two types of iron and steel plants will be discussed in this section: integrated and nonintegrated. Because cadmium can be present as a trace contaminant in process feed materials such as coal, iron ore, and scrap metal, process operations in both plant types are potential cadmium emission sources.

Integrated iron and steel plants are those iron and steelmaking facilities that are capable of starting with iron ore as a raw material feed and producing finished steel products. At a minimum, these facilities have blast furnace facilities for pig iron production; steelmaking furnaces (generally one or more basic oxygen furnaces), and steel finishing operations. Many

facilities also have coke making operations, sinter plants, and electric arc furnace shops for melting scrap. In its simplest form, the integrated iron and steel process begins with pig iron production from iron ore or pellets in the blast furnace. The molten iron is transferred from the blast furnace to the basic oxygen furnace, where the hot pig iron and scrap metal are heated and transformed metallurgically to carbon steel. This carbon steel is then cast and rolled into a final product. Table 8-1 provides a listing of integrated iron and steel plant locations.

Nonintegrated plants consist of "minimills" or specialty mills that produce carbon steel, stainless steel and other steel alloys from scrap. Typical operations at these facilities include electric arc furnaces for steelmaking and steel casting and finishing operations, as well as alloying operations. Table C-1 lists those facilities that use electric arc furnaces.

Total steel (carbon and alloy) production for 1991 was  $79.7 \times 10^6$  Megagrams (Mg) ( $87.8 \times 10^6$  tons). Of this total,  $70.7 \times 10^6$  Mg ( $77.9 \times 10^6$  tons) was carbon steel. In 1991, nonintegrated plants produced  $9.1 \times 10^6$  Mg ( $10.0 \times 10^6$  tons) of stainless and alloy steel.<sup>1</sup> In order to distribute this production among furnace types, basic oxygen and open hearth furnaces were assumed to produce only carbon steel. Using this assumption estimated 1991 production levels for carbon steel were  $47.8 \times 10^6$  Mg ( $52.7 \times 10^6$  tons) in basic oxygen furnaces,  $1.3 \times 10^6$  Mg ( $1.4 \times 10^6$  tons) in open hearth furnaces, and  $16.7 \times 10^6$  Mg ( $18.4 \times 10^6$  tons) in electric arc furnaces. The total stainless and alloy steel production of  $9.1 \times 10^6$  Mg ( $10.0 \times 10^6$  tons/yr) is assumed to be from electric arc furnaces. Intermediates produced by integrated iron and steel plants in 1991 include  $44.1 \times 10^6$  Mg ( $48.6 \times 10^6$  tons) of pig iron and  $21.8 \times 10^6$  Mg ( $24.0 \times 10^6$  tons) of coke (including both furnace and merchant coke plants but excluding coke breeze).

TABLE 8-1. INTEGRATED IRON AND STEEL PLANTS

| Company                                      | Facility              | City and State     | No. of basic oxygen furnaces | No. of blast furnaces |
|--|-----------------------|--------------------|------------------------------|-----------------------|
| Acme Steel Company                           | Chicago Plant         | Chicago, IL        | 2                            | 2                     |
| Acme Steel Company                           | Riverdale Works       | Riverdale, IL      | 2                            | 1                     |
| Allegheny Ludlum Corp.                       | Brankenridge Works    | Natrona, PA        | 2                            | 1                     |
| Armco Steel Company, L.P. <sup>a</sup>       | Ashland Works         | Ashland, KY        | 2                            | 2                     |
| Armco Steel Company, L.P. <sup>a</sup>       | Hamilton Plant        | Hamilton, OH       | -                            | 2                     |
| Armco Steel Company, L.P.                    | Middletown Works      | Middletown, OH     | 2                            | 2                     |
| Bethlehem Steel Corp.                        | Bethlehem Plant       | Bethlehem, PA      | 2                            | 4                     |
| Bethlehem Steel Corp. <sup>a</sup>           | Burns Harbor Plant    | Burns Harbor, IN   | 3                            | 2                     |
| Bethlehem Steel Corp. <sup>a</sup>           | Sparrows Pt. Plant    | Sparrows Pt., MD   | 2                            | 3                     |
| Geneva Steel Company <sup>a</sup>            | Geneva Works          | Orem, UT           | 1                            | 3                     |
| Gulf States Steel <sup>a</sup>               |                       |                    |                              |                       |
| Inland Steel Company <sup>b</sup>            |                       | Gadsen, AL         | 2                            | 1                     |
| LTV Steel Flat Rolled & Bar Co.              | Gadsen Works          | East Chicago, IN   | 4                            | 9                     |
| LTV Steel Flat Rolled & Bar Co. <sup>a</sup> | Cleveland Works       | Cleveland, OH      | 4                            | 5                     |
| LTV Steel                                    | Indiana Harbor Works  | East Chicago, IN   | 2                            | 2                     |
|  | LTV Stills            | Chicago, IL        | 1                            | 1                     |
| McLouth Steel                                | Trenton Works         | Trenton, MI        | 5                            | 2                     |
| National Steel Corporation                   | Granite City Steel    | Granite City, IL   | 2                            | 2                     |
| National Steel Corporation                   | Great Lakes Steel     | Ecorse, MI         | 2                            | 3                     |
| Rouge Steel Company                          | Rouge Works           | Dearborn, MI       | 2                            | 2                     |
| Sharon Steel, Incorporated                   | Farrell Works         | Farrell, PA        | 2                            | 1                     |
| Sharon Steel, Incorporated                   | Monessen, Inc.        | Sharon, PA         | -                            | 1                     |
| U.S. Steel Corporation (USX)                 | Edgar Thomson Plant   | Braddock, PA       | 2                            | 2                     |
| U.S. Steel Corporation (USX)                 | Fairfield Works       | Fairfield, AL      | 3                            | 1                     |
| U.S. Steel Corporation (USX)                 | Fairless Works        | Fairless Hills, PA | 1                            | 2                     |
| U.S. Steel Corporation (USX) <sup>a</sup>    | Gary Works            | Gary, IN           | 6                            | 5                     |
| USS/Kobe Steel Company                       |                       |                    |                              |                       |
| Warren Consolidated Inc.                     |                       | Lorain, OH         | 2                            | 4                     |
| Weirton Steel Company <sup>a</sup>           | Warren Facility       | Warren, OH         | 2                            | 1                     |
| Wheeling-Pittsburgh Steel Corp.              | Weirton Works         | Weirton, WV        | 2                            | 4                     |
| Wheeling-Pittsburgh Steel Corp. <sup>c</sup> | Steubenville Plant, N | Steubenville, OH   | 2                            | 2                     |
|  | Steubenville Plant, S | Mingo Junction, OH | 1                            | 2                     |
|  |                       | TOTAL              | 65                           | 74                    |

Source: Reference 2.

<sup>a</sup>Also has a sinter plant at this location.

<sup>b</sup>Has a sinter plant at the Indiana Harbor Works facility.

<sup>c</sup>Has a sinter plant at the Follansbee Plant, Follansbee, WV.



## Process Description

Figure 8-1 provides a flow diagram for iron and steel production. The principal components of the process are iron production, steelmaking, and steel finishing. However, two important ancillary components are coke making and sinter production. The process steps discussed below apply to an integrated plant. Process differences will be noted for nonintegrated plants.

Frequently, the first step in the process for an integrated plant is to produce metallurgical coke (elemental carbon) for the blast furnace. Coke is used to: (1) provide a substrate for raw materials in the blast furnace, (2) function as fuel for the hot blast air, and (3) remove iron ore oxides. Table 8-2 lists the coke production capacities for batteries located at or associated circle integrated plants. Nonintegrated plants do not use blast furnaces and, therefore, do not need coke. The coke is made from coal that is pulverized and then heated in a coke oven without oxygen at 1050°C (1925°F) for 12 to 20 hours. Volatiles are driven off, and elemental carbon (coke) and ash are formed. Because cadmium is a trace contaminant in coal, there is a potential for emissions when the coal is heated.

Two types of ovens (arranged in batteries) can be used: a slot oven and a nonrecovery oven. The slot oven process recovers volatiles that are driven off during the heating process, and these volatiles are refined to produce coke-oven gas, tar, sulfur, ammonium sulfate and light oil. Because most of the volatile materials generated by the oven are cycled through recovery process with organic condensation steps, cadmium emissions generated by by-product cokemaking facilities is

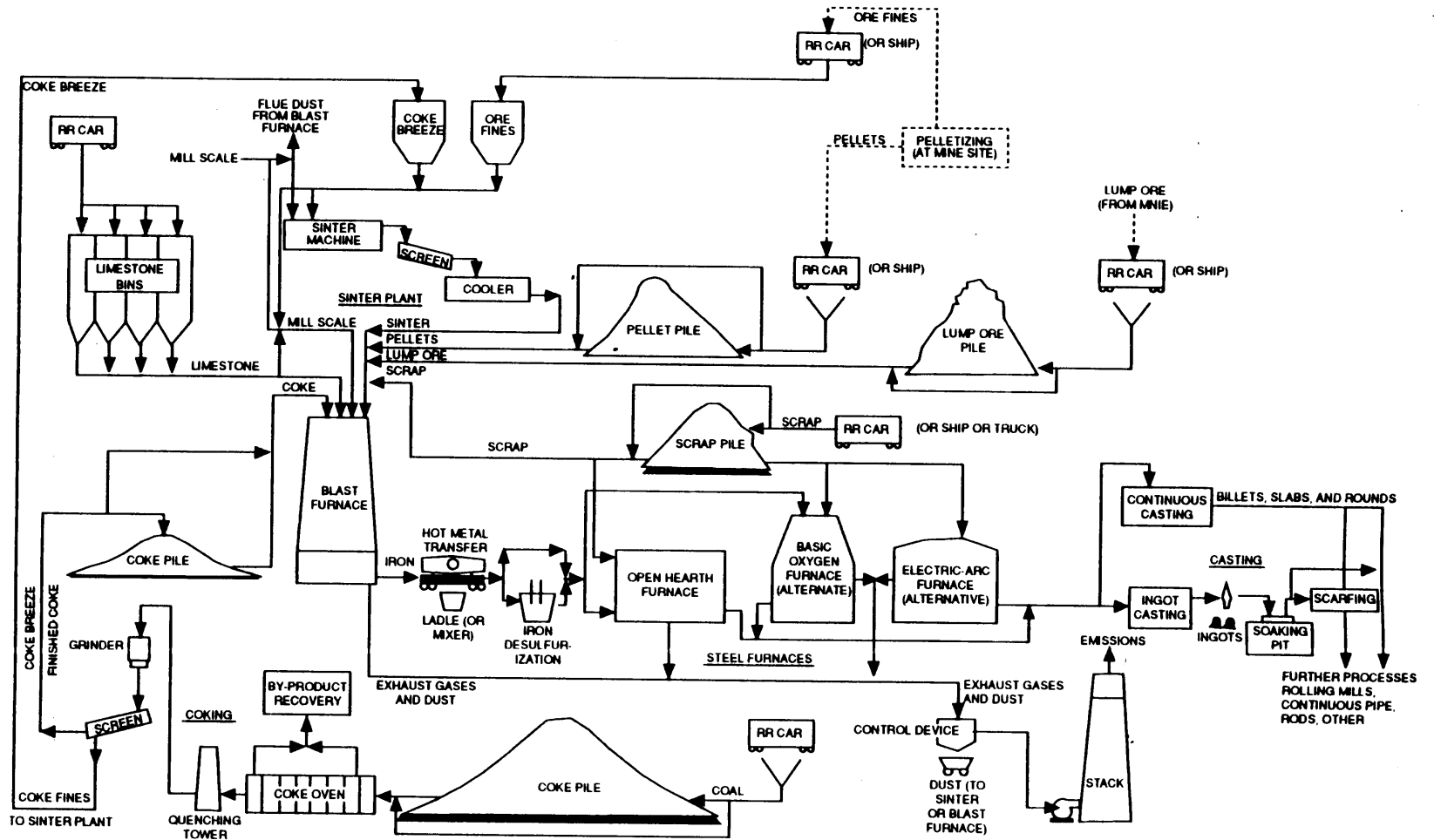

Figure 8-1. General flow diagram for the iron and steel industry. 90

TABLE 8-2. COKE PRODUCTION CAPACITY FOR INTEGRATED IRON AND STEEL FACILITIES  
IN THE UNITED STATES IN 1991

| Facility   | No. of batteries | Total No. of ovens | Total capacity    |              |
|--|------------------|--------------------|-------------------|--------------|
|  |                  |                    | Megagrams per day | Tons per day |
| Acme Steel, Chicago, IL                          | 2                | 100                | 1,626             | 1,600        |
| Armco, Inc., Ashland, KY                         | 2                | 146                | 2,743             | 2,700        |
| Armco, Inc., Middletown, OH                      | 3                | 203                | 4,608             | 4,535        |
| Bethlehem Steel, Bethlehem, PA                   | 3                | 284                | 4,007             | 3,944        |
| Bethlehem Steel, Burns Harbor, IN                | 2                | 164                | 4,400             | 4,380        |
| Bethlehem Steel, Lackawanna, NY                  | 2                | 152                | 1,902             | 1,872        |
| Bethlehem Steel, Sparrows Point, MD              | 3                | 210                | 4,134             | 4,069        |
| Geneva Steel, Orem, UT                           | 1                | 208                | 2,323             | 2,250        |
| Gulf States Steel, Gadsden, AL                   | 2                | 130                | 2,845             | 2,800        |
| Inland Steel, East Chicago, IN                   | 6                | 446                | 5,868             | 5,775        |
| LTV Steel, Pittsburgh, PA                        | 5                | 315                | 5,491             | 5,404        |
| LTV Steel, Chicago, IL                           | 1                | 60                 | 1,626             | 1,600        |
| LTV Steel, Cleveland, OH                         | 2                | 126                | 3,251             | 3,200        |
| LTV Steel, Warren, OH                            | 1                | 85                 | 1,524             | 1,500        |
| National Steel, Granite City, IL                 | 2                | 90                 | 1,544             | 1,520        |
| National Steel, Ecorse, MI                       | 1                | 78                 | 940               | 925          |
| USS, Div. of USX Corp., Clairton, PA             | 12               | 816                | 12,843            | 12,640       |
| USS, Div. of USX Corp., Gary, IN                 | 6                | 422                | 7,249             | 7,135        |
| Wheeling-Pittsburgh Steel, East Steubenville, WV | 4                | 224                | 3,861             | 3,800        |
| Total  | 60               | 4,259              | 72,835            | 71,649       |

SOURCE: Reference 5.

expected to be negligible. However, nonrecovery ovens do not recover volatiles and instead combust them. These ovens may be a source of cadmium emissions.

After the coking cycle is complete, the coke is quickly cooled down by a quenching tower, to prevent product loss via combustion. Further cooling occurs after the water is drained from the coke, it is sized to remove the undersized material (coke breeze) and transferred to storage piles. Because cadmium may remain as a trace contaminant in the coke, small quantities of cadmium may be released as fugitive emissions during these handling, transfer, and storage operations.

A second ancillary process found at many integrated plants is the sintering operation. The sintering process is a materials-recovery process, which converts fine-sized raw materials, including iron ore, coke breeze, limestone, mill scale, and flue dust, into an agglomerated product called "sinter."<sup>4</sup> Cadmium can be contained in the iron ore used to produce sinter and may be emitted when the sinter mixture is combusted. The raw materials are placed on a continuous, travelling grate called the sinter strand. A burner hood, at the beginning of the sinter strand, ignites the coke in the mixture. Combustion air is drawn down through the material bed and into a common duct leading to a gas cleaning device. The fused sinter is discharged from the sinter strand where it is crushed and screened. Undersized sinter is recycled to the mixing mill and back to the strand. The remaining sinter product is cooled in the open air or in a circular cooler with water sprays or mechanical fans.

The initial process common to all integrated plants is the blast furnace, which is used to produce molten iron ("pig iron"). Iron ore, coke, limestone flux and sinter are introduced

("charged") into the top of the furnace. Heated air is injected through the bottom of the furnace. This blast air combusts the coke contained in the breeze to melt the sinter, and flux with the iron oxides in the ore and form molten iron, slag, and carbon monoxide (CO). The molten iron and the slag collect in the hearth at the base of the furnace and are periodically tapped. The CO is collected through offtakes at the top of the furnace. Because the iron ore contains traces of cadmium, emissions are possible as particulate matter (PM) entrained in the CO. However, this CO will be used as fuel within the plant after it is cleaned of PM; consequently, cadmium emissions are expected to be negligible.

The molten iron from the blast furnace undergoes desulfurization, after which it is introduced to a basic oxygen furnace (BOF) or open hearth furnace to make steel. These furnaces use oxygen as a refining agent. In a BOF, the raw material is typically 70-percent molten metal and 30-percent scrap metal. Again, cadmium may be present as a contaminant in the scrap metal. The oxygen reacts with carbon and other impurities in the raw material and removes them from the molten metal. Large quantities of carbon monoxide (CO) are produced by the exothermic reactions in the BOF. These gases, which may contain cadmium, frequently are burned at the mouth of the furnace to oxidize CO. The gases are then vented to gas cleaning devices before being discharged to the atmosphere.

There are two types of BOF's. Conventional BOF's blow oxygen into the top of the furnace through a water-cooled lance. The newer Quelle Basic Oxygen process (Q-BOP) furnaces inject oxygen through tuyeres, which are located in the bottom of the furnace. Typical cycles involve scrap charge, hot metal charge, oxygen blow (refining) period, testing for temperature and chemical composition of the steel, alloy additions and reblows

(if necessary), tapping, and slagging. The full furnace cycle typically ranges from 25 to 45 minutes.

The open-hearth furnace (OHF) is a shallow, refractory-lined basin in which scrap and molten iron are melted together and then refined into steel. The mixture of scrap and hot metal may consist of either all scrap or all hot metal, but a half-and-half mixture of scrap and metal is common. Because scrap is used, there is a potential for cadmium emissions; however, no information was available to evaluate emissions potential. Because these furnaces have limited use and are being eliminated, they are not considered a significant cadmium emission sources.

Nonintegrated plants use electrical arc furnaces (EAF's) to produce carbon and alloy steels. The raw material for an EAF is typically 100 percent scrap, which is a source for cadmium emissions. These furnaces are cylindrical and refractory-lined. They have carbon electrodes that are raised or lowered through the furnace roof. With electrodes raised, the furnace roof can be moved aside to allow scrap steel to be introduced by an overhead crane. Alloying agents and fluxing materials are usually added through the doors on the side of the furnace. Heat generated by the electrical current passing between the electrodes is used to melt the scrap. After melting and refining periods, the slag and steel are poured from the furnace by tilting. The production of steel in an EAF is a batch process. Cycles, or "heats," range from about 1 1/2 to 5 hours for carbon steel production and from 5 to 10 hours, or more, for alloy steel production. Because cadmium may be contained in the scrap metal used to feed EAF's, they are considered to be a potential source of cadmium emissions.

After production in either a BOF, OHF, or EAF, the molten steel is cast into molds or is continuously cast to form a finished product. This final product consists of shapes called blooms, slabs, and billets. No cadmium emissions are expected from this final process step from the cold steel, because cadmium is not expected to be present in the molten steel product.

#### Emission Control Measures<sup>2</sup>

Cadmium is usually emitted as fine particulate matter from high temperature operations such as the furnaces found in the iron and steel plants.<sup>6</sup> Cadmium emissions from iron and steel production are expected from furnaces, BOF's, OHF's, EAF's, sintering operations, and possibly, charging of by-product ovens and nonrecovery coke oven operations. No specific data were available on cadmium control from iron and steel operations. However, because these processes generate primarily fine particles, the cadmium control efficiencies are assumed to be equivalent to the overall PM control efficiencies for electrostatic precipitators, high energy scrubbers, and fabric filters applied to high temperature processes.

Information available on one nonrecovery oven shows that charging emissions are controlled with a travelling hood that vents to a baghouse.<sup>7</sup> Total capture efficiency was estimated at 70 percent, and cadmium was not detected in the baghouse samples. The detection level was 0.5 milligram per kilogram (mg/kg) [parts per million (ppm)].<sup>7</sup> Therefore, it can be assumed there are no significant cadmium emissions from nonrecovery coke ovens.

Estimates on control device efficiency for PM are available for ESP's, scrubbers, and baghouses used in sintering operations. These efficiencies range from 93 percent (for a

cyclone, ESP, scrubber configuration) to 99.9 percent (for a baghouse) and are based on State permitting information.

Controls used for blast furnaces include cyclones or gravity collectors in combination with scrubbers, baghouses, and ESP's. Efficiencies for baghouses ranged from 98 to 99.25 percent. If followed by a scrubber, they could be as high as 99.9 percent. Gravity collectors used with scrubbers could achieve 99 to 99.9 percent efficiency. Scrubbers used with an ESP have removal efficiencies of 99.3 to 99.9 percent.

Control devices used for BOF's include scrubbers, fabric filters and ESP's. Control efficiency estimates are: (1) 99.4 to 99.7 percent for ESP's, (2) 98.5 to 99.9 percent for scrubbers, (3) 99 percent for baghouses, and (4) 96 percent for a cyclone with scrubber. No information was available on control devices used for open hearth furnaces.

Because a substantial portion of the emissions from an EAF are fugitive in nature, emission control systems include capture and collection systems. The capture systems include a primary system, which is designed to capture emissions during the melt, and a secondary system, which is designed to capture fugitive emissions from charging, tapping, and furnace leakage. Typically, primary collection systems are either direct shell evacuation (DSE) systems (also called fourth hole systems) or side draft hood systems, and secondary emissions are collected via canopy hoods, close-capture local hoods, or furnace enclosures. Gases collected by these systems are generally directed to a fabric filter for PM collection. Available information indicates that properly designed and operated secondary systems are expected to capture 75 to 95 percent of the emissions from EAF's, while DSE systems collect 99 percent of the emissions generated during the melt. Performance data for fabric



filters are generally presented as achievable outlet concentration levels but well-operated units are expected to achieve efficiencies that exceed 99 percent.

### Emissions<sup>1,8</sup>

Table 8-3 summarizes cadmium releases reported in the 1990 Toxic Chemical Release Inventory (TRI). Test data for cadmium emissions are only available from one plant, Bethlehem Steel at Sparrows Point, Maryland. Because these data are not complete and could not be validated, they should be used cautiously. It should be noted that this particular plant reported no cadmium emissions in the 1990 TRI. The test data for this one facility are summarized in Table 8-4, but no information is available on their representativeness.

No specific data for cadmium emissions from EAF's were found in the literature, and no emission test data were available to permit the calculation of cadmium emissions.

### PORTLAND CEMENT MANUFACTURING

More than 30 raw materials are used to manufacture Portland cement. These materials can be classified into four basic classes of raw materials: lime, silica, alumina, and iron. Two processes, the wet and dry processes, can be used to manufacture Portland cement. In 1990, there were a total of 212 U.S. cement kilns with a combined total clinker capacity of  $73,518 \times 10^3$  Mg ( $81,056 \times 10^3$  tons). Of this total, 11 kilns with a combined capacity of  $1,767 \times 10^3$  Mg ( $1,948 \times 10^3$  tons) were inactive. The total number of active kilns was 201 with a clinker capacity of  $71,751 \times 10^3$  Mg ( $79,108 \times 10^3$  tons).<sup>11</sup> The name, location, and clinker capacity of each kiln is presented in Appendix C. Based on 1990 U.S. cement kiln capacity data, an

TABLE 8-3. CADMIUM RELEASES REPORTED BY IRON AND STEEL FACILITIES IN 1990 TRI

| Facility/location                            | Total releases |        |
|--|----------------|--------|
|  | kg/yr          | lb/yr  |
| ARMCO, Kansas City, MO                       | 115.7          | 255    |
| ASARCO, East Helena, MT                      | 8,164.7        | 18,000 |
| Barbary Coast Steel Corp., Kent, WA          | 25.4           | 56     |
| Bethlehem Steel, Bethlehem, PA               | 176.9          | 390    |
| Birmingham Bolt, Birmingham, AL              | 46.3           | 102    |
| Birmingham Bolt, Bourbonnais, IL             | 50.3           | 111    |
| Bloomfield Foundry Inc., Bloomfield, IA      | 4.54           | 10     |
| BSC Steel, Jackson, MS                       | 21.3           | 47     |
| Cascade Steel Rolling Mills, McMinnville, OR | 113.4          | 250    |
| Citisteel USA, Clairmont, DE                 | 113.4          | 250    |
| Dana Corp., Richmond, IN                     | 4.54           | 10     |
| East Jordan Iron Works, East Jordan, MI      | 2.27           | 5      |
| GMC Saginaw Grey Iron Plant, Saginaw, MI     | 115.7          | 255    |
| John Deere Foundry, Waterloo, IA             | .45            | 1      |
| Lukens Steel, Coatesville, PA                | 39.9           | 88     |
| Newport Steel Corp., Newport, KY             | 2.27           | 5      |
| Norfolk Steel Corp., Chesapeake, VA          | 4.54           | 10     |
| Nucor Steel, Polymouth, UT                   | 82.1           | 181    |
| Salmon Bay Steel Corp., Kent, WA             | 9.98           | 22     |
| Seattle Steel, Seattle, WA                   | 226.8          | 500    |
| Sheffield Steel Corp., Sand Springs, OK      | 2.27           | 5      |
| Roanoke Electric Steel, Roanoke, VA          | 207.3          | 457    |
| Rouge Steel, Dearborn, MI                    | 16.33          | 36     |
| TOTAL  | 9,546.4        | 21,046 |

Source: Reference 9.

TABLE 8-4. CADMIUM EMISSIONS REPORTED FROM BETHLEHEM STEEL,  
SPARROWS POINT, MARYLAND

| Operation source                                | Emissions |       |
|---|-----------|-------|
|   | kg/yr     | lb/yr |
| Sintering                                       |           |       |
| -- Transfer points controlled by scrubber       | 0.59      | <1.3  |
| Limestone stockpile (fugitives)                 | 0.45      | 1     |
| Coke breeze unloading (fugitives)               | 1.8       | 4     |
| Stock House (fugitives)                         | 39.9      | 88    |
| -- Windbox and discharge controlled by baghouse | 0.27      | <0.6  |
| Blast furnace                                   |           |       |
| -- Uncontrolled casthouse roof monitor          | 1.36      | 3.0   |
| -- Taphole and trough (not runners)             | 0.91      | 2.0   |
| Basic oxygen furnace (BOF)                      |           |       |
| -- Uncontrolled                                 | 0.45      | 1     |
| -- Fugitives                                    | 1.36      | 3     |
| BOF charging                                    |           |       |
| -- At source                                    | 0.45      | 1     |
| -- Controlled by baghouse                       | 0.045     | 0.1   |
| -- Hot metal transfer at source                 | 0.91      | 2.0   |
| BOF tapping                                     | 4.99      | 11.00 |

Source: References 2 and 3.

<sup>a</sup>Typical of older furnaces with no controls, or for canopy hoods or total casthouse evacuation.

estimated 68 percent of the Portland cement is manufactured using the dry process, and the remaining 32 percent is based on the wet process. A description of the processes used to manufacture Portland cement and a discussion of the emissions resulting from the various operations are presented below.

### Process Description<sup>3,10</sup>

Figure 8-2 presents a basic flow diagram of the Portland cement manufacturing process. The process can be divided into four major steps: raw material acquisition and handling, kiln feed preparation, pyroprocessing, and product finishing.

The initial step in the production of Portland cement manufacturing is raw materials acquisition. Calcium, which is the element of highest concentration in Portland cement, is obtained from a variety of calcareous raw materials, including limestone, chalk, marl, sea shells, aragonite, and an impure limestone known as "natural cement rock." The other raw materials--silicon, aluminum, and iron--are obtained from ores and minerals, such as sand, shale, clay, and iron ore. Cadmium is expected to be present in the ores (primarily iron, zinc, lead and copper) and minerals extracted from the earth.<sup>6</sup> The only potential source of cadmium emissions from raw material acquisition would be due to windblown cadmium-containing particulate from the quarry operations.

The second step involves preparation of the raw materials for pyroprocessing. Raw material preparation includes a variety of blending and sizing operations designed to provide a feed with appropriate chemical and physical properties. The raw material processing differs somewhat for wet and dry process. At facilities where the dry process is used, the moisture content in the raw material, which can range between 2 and 35 percent, is

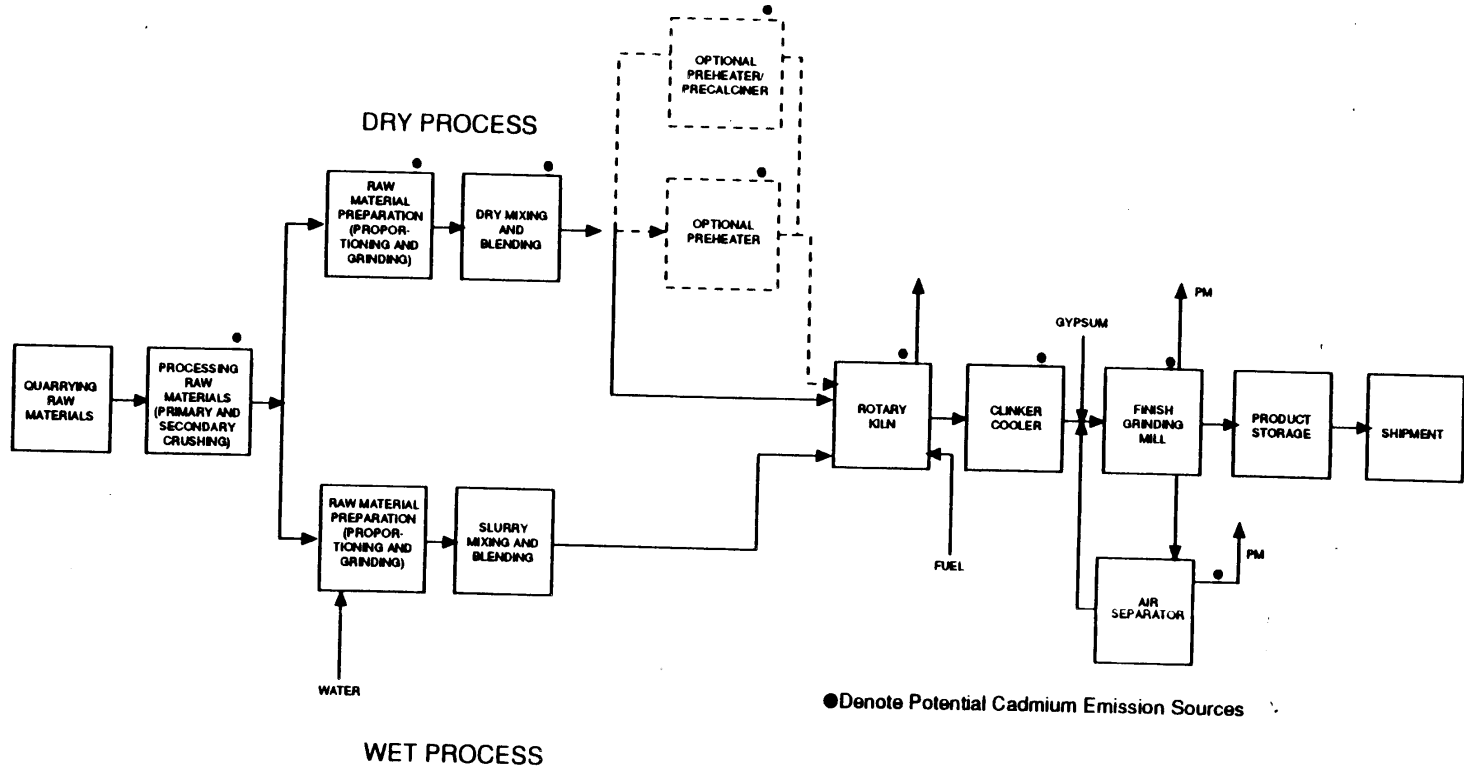

Figure 8-2. Process flow diagram of portland cement manufacturing process. 90,109

reduced to less than 1 percent. Cadmium emissions can occur during this drying process. The level of the emissions will depend upon the chemical form of the mercury in the raw material and the temperature and duration of the drying process. Heat for drying is provided by the exhaust gases from the pyroprocessor. At facilities where the wet process is used, water is added to the raw material during the grinding step, thereby producing a pumpable slurry containing approximately 65 percent solids.

Pyroprocessing (thermal treatment) of the raw material is carried out in the kiln, which is the heart of the Portland cement manufacturing process. During pyroprocessing, the raw material is transformed into clinkers, which are gray, glass-hard, spherically-shaped nodules that range from 0.32 to 5.1 cm (0.125 to 2.0 in.) in diameter. The chemical reactions and physical processes that take place during pyroprocessing include:

1. Evaporation of uncombined water from raw materials as material temperature increases to 100°C (212°F),
2. Dehydration and precalcination as the material temperature increases from 100°C to approximately 430°C (806°F),
3. Calcination during which carbon dioxide (CO<sub>2</sub>) is evolved, between 430°C and 900°C (1652°F),
4. Sintering of the oxides in the burning zone of the rotary kiln at temperatures up to 1510°C (2750°F), and
5. Production of cement clinker as the temperature decreases from 1510°C to 1370°C (2498°F).

The rotary kiln is a long, cylindrical, slightly inclined, refractory-lined furnace. The raw material mix is introduced in

the kiln at the elevated end, and the combustion fuels are introduced into the kiln at the lower end, in a countercurrent manner. The rotary motion of the kiln transports the raw material from the elevated end to the lower end. Fuel such as coal, oil, or natural gas is used to provide energy for calcination. Use of other fuels, such as shredded municipal garbage, chipped rubber, coke, and waste solvents, is becoming increasingly popular.

Pyroprocessing can be carried out using one of four different processes: wet process, dry process, dry process with a preheater, and dry process with a preheater/precalciner. These processes essentially accomplish the same physical and chemical steps described above. Depending on the prevalence of preheaters and precalciners at facilities where Portland cement is manufactured by the dry process, these segments of the process can be the primary sources of cadmium emissions. This is because cadmium present in the raw material can evaporate readily during the preheating and precalcining steps. The last step in the pyroprocessing is the cooling of the clinker. This process step recoups up to 30 percent of the heat input to the kiln system, locks in desirable product qualities by freezing mineralogy, and makes it possible to handle the cooled clinker with conventional conveying equipment. Finally, after the cement clinker is cooled, a sequence of blending and grinding operations is carried out to transform the clinker into finished Portland cement.

#### Emission Control Measures

With the exception of the pyroprocessing operations, the emission sources in the Portland cement industry can be classified as either process fugitive or open dust emissions. The primary pollutants resulting from these fugitive sources are PM. The control measures used for these fugitive dust sources

are comparable to those used throughout the mineral products industries.

Methods used to reduce particulate levels in the ambient air due to vehicular traffic include paving and road wetting. Additional methods that are applied to other open dust sources include wet sprays, with and without surfactants, chemical dust suppressants, wind screens, and process modifications to reduce drop heights or enclose storage operations.

Process fugitive emission sources include materials handling and transfer, raw milling operations in dry process facilities, and finish milling operations. Cadmium emission sources are indicated in Figure 8-2 by solid circles. Typically, particulate emissions from these processes are captured by a ventilation system comprising one or more mechanical collectors with a fabric filter in a series. Because the dust from these units is returned to the process, they are considered to be process units as well as air pollution control devices. The industry uses shaker, reverse air, and pulse jet filters, as well as some cartridge units, but most newer facilities use pulse jet filters. For process fugitive operations, the different systems are reported to achieve typical outlet PM loadings of 45 milligrams per cubic meter  $\text{mg}/\text{m}^3$  (0.02 grains per actual cubic foot [gr/acf]). Because the cadmium is in particle form, the performance of these systems relative to cadmium control is expected to be equivalent to this overall particulate performance. However, no data are available on cadmium performance of fugitive control measures.

In the pyroprocessing units, PM emissions are controlled by fabric filters (reverse air, pulse jet, or pulse plenum), electrostatic precipitators (ESP's), and electrified gravel bed (EGB) filters. The reverse air fabric filters and ESP's



typically used to control kiln exhausts are reported to achieve outlet PM loadings of 45 mg/m<sup>3</sup> (0.02 gr/acf). Clinker cooler systems are controlled most frequently with pulse jet or pulse plenum fabric filters, but reverse air fabric filters, ESP's, and EGB's are becoming increasingly popular. No data are available on the performance of these control systems for cadmium emissions.

### Emissions

Emissions resulting from all four processing steps include particulate matter. Additionally, emissions from the pyroprocessing step include other products of fuel combustion such as sulfur dioxide (SO<sub>2</sub>), nitrogen oxides (NO<sub>x</sub>), and carbon monoxide (CO). Cadmium emissions can be expected from the rotary kiln or preheater/precalciner, if used in the process. Cadmium that may be present in the raw material and the fuel can potentially be emitted from either of these sources. As the use of municipal waste and hazardous waste becomes more prevalent as an auxiliary fuel, the likelihood for cadmium emissions may increase significantly. Table 8-5 provides emission factors based on emission tests conducted during a new source performance standard (NSPS) development for Portland cement plants

### PHOSPHATE ROCK PROCESSING

Phosphate rock, a calcium phosphate mineral known as apatite (Ca<sub>10</sub>(PO<sub>4</sub>)<sub>6</sub>F<sub>2</sub>) is mined and processed by beneficiation, drying or calcining, and grinding.<sup>12</sup> As a natural impurity in the phosphate rock, cadmium emissions may occur during any thermal processing of the rock. Florida ores can contain 2 to 15 parts per million (ppm) of cadmium; North Carolina ores, 10 to 25 ppm; Tennessee ores, 0.1 to 2 ppm; and western ores (mainly Idaho), 2 to 980 ppm with a median concentration of 200 ppm.<sup>12</sup>

TABLE 8-5. CADMIUM EMISSION FACTORS FROM PORTLAND CEMENT FACILITIES

| Process                        | Emission Factor       |                       | Ref. <sup>a</sup> |
|--------------------------------|-----------------------|-----------------------|-------------------|
|                                | kg/Mg of feed         | lb/ton of feed        |                   |
| Raw Mill-Air Separator         | $4.43 \times 10^{-7}$ | $8.87 \times 10^{-7}$ | 1                 |
| Finishing Mill - Weigh Hopper  | $7.56 \times 10^{-7}$ | $1.51 \times 10^{-6}$ | 1                 |
| Finishing Mill - Air Separator | $1.30 \times 10^{-6}$ | $2.59 \times 10^{-6}$ | 1                 |
| Clinker Cooler                 | $8.7 \times 10^{-6}$  | $1.7 \times 10^{-5}$  | 2                 |
| Wet Rotary Kiln                | $1.1 \times 10^{-4}$  | $2.2 \times 10^{-4}$  | 2                 |

Source: Reference 10.

- <sup>a</sup>1. Source test: Emissions from Dry Process Raw Mill and Finish Mill Systems at Ideal Cement Company, Tijeras, New Mexico. ETB Test number 71-MM-02. 1972.
2. Source test: Emissions from Wet Process Cement Kiln and Clinker Cooler at Ideal Cement Company, Seattle, Washington. ETB Test number 71-MM-03. 1972.

While fertilizer production is the major use for phosphate rock, the rock can also be used to produce phosphoric acid and elemental phosphorus. These industries are not considered part of the phosphate rock processing industry; however, because they use phosphate rock as a raw material they are briefly summarized. Phosphoric acid is produced by digesting the phosphate rock with sulfuric acid, and pure phosphorus is manufactured in an electric arc or blast furnace from phosphate rock and silica.<sup>13,14</sup>

A number of fertilizers are produced depending on the phosphate content of the rock. These fertilizers are: normal superphosphate, triple superphosphate; and ammonium phosphate. No thermal processing is used in fertilizer production; therefore, it is not considered a significant source of cadmium emissions. Additionally, no data are available that quantify cadmium air emissions during the chemical reactions that produce fertilizers. Since there is also no thermal processing during phosphoric acid production, this process is not considered to be a cadmium emission source.

Using an EAF in elemental phosphorus production is a thermal treatment process and the EAF may be a cadmium emission source. The rock is heated in a large furnace with coke and silica to temperatures of 1300° to 1500°C (2372° to 2732°F) to produce phosphorus vapor. Elemental phosphorus is condensed to a liquid in cooling towers with water sprays at 45° to 55°C (113° to 131°F).<sup>14</sup>

Drying or calcining phosphate rock, are also thermal treatment processes, and are considered cadmium emission sources for phosphate rock processing. These potential emission sources are discussed in more detail in the process description.

Table C-3 in Appendix C lists those companies, as of January 1, 1991, which mine phosphate rock and their annual capacities. In 1991, 154.5 million Mg (340 million tons) of phosphate rock were mined and 48.1 million Mg (106 million tons) were marketed after processing.<sup>15</sup> Of that amount, Florida and North Carolina produced 149.8 million Mg (330 million pounds). The remaining 4.7 million Mg (10.3 million tons) were mined in Idaho, Montana, Tennessee, and Utah.<sup>15</sup> Annual plant production capacity was reported as 59.1 million Mg (130 million tons) in 1991.<sup>16</sup>

Known EAF operations that produce elemental phosphorus from phosphate rock are in Pocatello, Idaho; Silver Bow, Montana; and Soda Springs, Idaho (Monsanto). These producers and their capacities are listed in Table C-4 in Appendix C.

### Process Description<sup>3</sup>

Figure 8-3 provides a flow diagram for the overall processing of the rock for manufacturing. Before manufacturing fertilizer or elemental phosphorus, the mined phosphate rock must be beneficiated, dried (or calcined), and ground.

Beneficiation requires removing clay, sand, or organic materials. Depending on where the rock was mined, it may need to be segregated by certain sizes for washing and further grinding. Once a particular size is reached, and all foreign materials have been removed, a wet rock mill grinds the final slurry to the consistency of fine beach sand. Hydrocyclones separate the slurry into rock and clay; then the rock is filtered out and allowed to dry in piles. Since this is a wet grinding process with no thermal treatment, no cadmium emissions are anticipated.

8-24

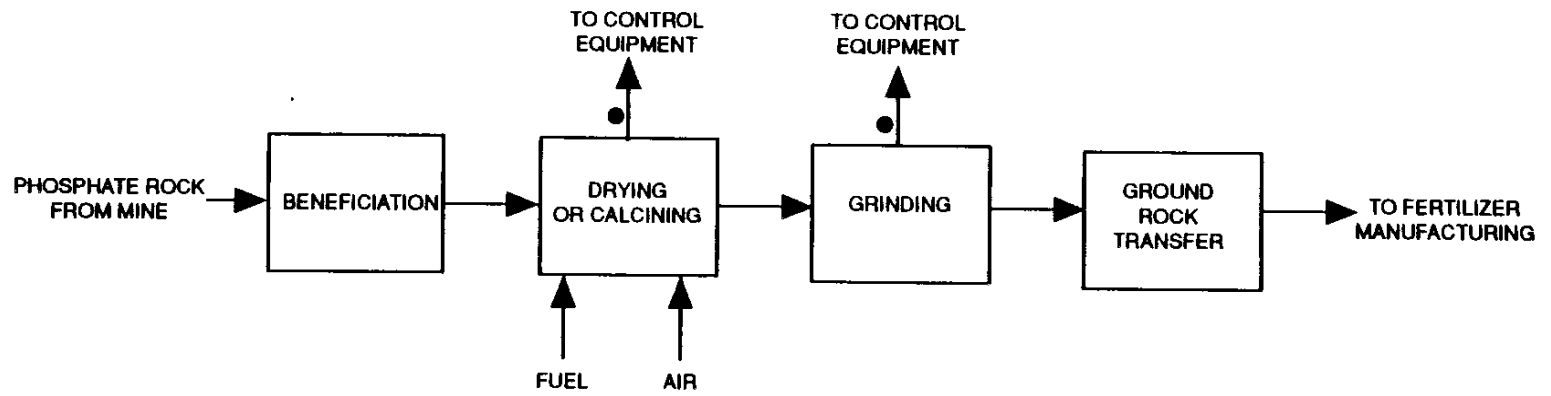

Figure 8-3. Typical flowsheet for processing phosphate rock.<sup>90</sup>

The organic content of the rock determines whether the rock is dried in rotary or fluidized-bed driers, or heated in fluidized-bed calciners. Rock free of organic contaminants is dried in dryers at temperatures around 120°C (248°F). Rotary driers are most commonly used and operate on natural gas or fuel oil (Nos. 2 or 6). Rock with organic contaminants is heated to 760°C to 870°C (1400°F to 1598°F), usually in fluidized-bed calciners. After heating or drying, the rock is conveyed to storage silos on protected conveyors for processing in the grinding mill. Since dryers and calciners are heat processes, it is believed there will be cadmium emissions from these sources.

After calcining or drying, the phosphate rock is sent to the grinding mills. Roller or ball mills are used to grind calcined phosphate rock into a fine powder; 60 percent (by weight) of this powder typically passes through a 200-mesh sieve. A rotary valve feeds the rock into the grinding mills, and circulating air streams remove the ground rock. Any remaining oversized particles are sent back into the mill for regrinding. Final product rock is separated by a cyclone for use in the next manufacturing step, usually to make fertilizers.

While grinding is not a heat treatment step, it is believed to be a source of fugitive particulate emissions from blown fine rock. This particulate may contain cadmium traces as noted previously.<sup>12</sup>

### Emission Control Measures<sup>3</sup>

Control equipment used for phosphate rock dryers usually consists of scrubbers or electrostatic precipitators. Fabric filters are not used. Venturi scrubbers with low pressure drops (12 inches of water, or 3,000 Pascal, (Pa)) can remove 80 to 99 percent of the particulates that are 1 to 10 micrometers in

diameter; and for particulates less than 1 micrometer, 10 to 80 percent may be removed. Scrubbers with high pressure drops (30 inches of water, or 7,500 Pa) can remove 96 to 99.9 percent (1 to 10 micrometer particulates) or 80 to 86 percent (less than 1 micrometer particulates). Electrostatic precipitators can remove 90 to 99 percent of all particulates. If a wet grinding process is used, a drying step and its particular emissions are eliminated.

Calciners also use scrubbers and sometimes fabric filters. One operating calciner uses an electrostatic precipitator. Grinders use fabric filters and scrubbers to control emissions. Operating the air circulating streams in grinders at negative pressure avoids fugitive emissions of rock dust.

Material handling systems for ground rock, such as elevators and conveyors, have a high potential for fugitive emissions. These emissions can be controlled by covering and enclosing conveyors, which have controlled discharge points. Material transfer areas are hooded and the hoods evacuated to a control device. Storage silos or bins that are vented to the atmosphere usually have fabric filters to control particulate emissions.

Electric arc furnace emissions from elemental phosphorous production are most often controlled by fabric filters, although venturi scrubbers and electrostatic precipitators can be used.<sup>17</sup>

### Emissions<sup>3</sup>

#### Phosphate Rock Processing--

The major cadmium particulate emissions from phosphate rock processing (to produce fertilizers) are associated with the processes of drying, calcining, and grinding. These emission

sources are shown by solid circles on Figure 8-3. Since beneficiation involves slurries of rock and water, there are no significant cadmium particulate emissions.

No data were available concerning measured cadmium emissions from drying, calcining and grinding. There are emission factors in AP-42 for uncontrolled PM from these particular processes, but no information is available on cadmium levels in this PM. Therefore, these factors cannot be used to provide information on potential cadmium emissions.

No specific data for cadmium emissions from phosphate rock processing were found in the literature, and no emission test data were available to permit the calculation of cadmium emissions.

#### Elemental Phosphorus Production--

Only one EAF reported cadmium emissions in the 1990 TRI, FMC Corporation in Pocatello, Idaho. Total releases of 3,966 kg (8,725 lb) were reported; emission factors were used to estimate nonpoint releases of 88 kg (194 lb) and the remaining point releases of 3,878 kg (8,532 lb) were based on monitoring data.<sup>9</sup> According to the Bureau of Mines, a number of EAF plants were closed by 1991, and the 1990 TRI probably reflects this declining production.<sup>9,15</sup>

#### CARBON BLACK PRODUCTION

Carbon black is an industrial chemical used as a reinforcing agent in rubber products, such as tires, and as a black pigment for printing inks, surface coatings, and paper and plastics.<sup>17</sup> Cadmium may be a contaminant in the raw materials used and may be emitted during carbon black production. Table 8-6 provides a listing of facilities producing carbon



TABLE 8-6. CARBON BLACK PRODUCTION FACILITIES

| Company   | Location                   | Type of process <sup>a</sup> | Annual capacity <sup>b</sup> |                    |
|---|----------------------------|------------------------------|------------------------------|--------------------|
|   |                            |                              | 10 <sup>3</sup> Mg           | 10 <sup>6</sup> lb |
| Cabot Corporation<br>North American Rubber Black Division                                       | Franklin, Louisiana        | F                            | 141                          | 310                |
|   | Pampa, Texas               | F                            | 32                           | 70                 |
|   | Villa Platte, Louisiana    | F                            | 127                          | 280                |
|   | Waverly, West Virginia     | F                            | 82                           | 180                |
| Chevron Corporation<br>Chevron Chemical Company, subsidiary<br>Olevins and Derivatives Division | Cedar Bayou, Texas         | A                            | 9                            | 20                 |
| Degussa Corporation   | Aransas Pass, Texas        | F                            | 57                           | 125                |
|   | Belpre, Ohio               | F                            | 59                           | 130                |
|   | New Iberia, Louisiana      | F                            | 91                           | 200                |
| Ebonex Corporation  | Melvindale, Michigan       | C                            | 4                            | 8                  |
| General Carbon Company  | Los Angeles, California    | C                            | 0.5                          | 1                  |
| Hoover Color Corporation  | Hiwassee, Virginia         | C                            | 0.5                          | 1                  |
| J.M. Huber Corporation  | Baytown, Texas             | F                            | 102                          | 225                |
|   | Borger, Texas              | F and T                      | 79                           | 175                |
|   | Orange, Texas              | F                            | 61                           | 135                |
| Phelps Dodge Corporation<br>Colombian Chemical Company, subsidiary                              | El Dorado, Arkansas        | F                            | 50                           | 110                |
|   | Moundsville, West Virginia | F                            | 77                           | 170                |
|   | North Bend, Louisiana      | F                            | 109                          | 240                |
|   | Ulysses, Kansas            | F                            | 36                           | 80                 |
| Sir Richardson Carbon & Gasoline Company  | Addis, Louisiana           | F                            | 66                           | 145                |
|   | Big Spring, Texas          | F                            | 52                           | 115                |
|   | Borger, Texas              | F                            | 98                           | 215                |
| Witco Corporation<br>Continental Carbon Company, subsidiary                                     | Phenix City, Alabama       | F                            | 27                           | 60                 |
|   | Ponca City, Oklahoma       | F                            | 66                           | 145                |
|   | Sunray, Texas              | F                            | 45                           | 100                |
| TOTAL   |                            |                              | 1,471                        | 3,240              |

Source: Reference 16.

<sup>a</sup>A = acetylene decomposition

C = combustion

F = furnace

T = thermal

<sup>b</sup>Capacities are variable and based on SRI estimates as of January 1, 1991

black, their annual capacity, and production processes. Total annual capacity as of 1991 was 1.47 million Mg (1.62 million tons).<sup>16</sup>

### Process Description<sup>18</sup>

Carbon black is produced by partial combustion of hydrocarbons. The most predominantly used process (which accounts for more than 98 percent of carbon black produced) is based on a feedstock consisting of a highly aromatic petrochemical or carbochemical heavy oil. Cadmium can be expected to be present in the feedstock. Although the cadmium content in the feedstock used to manufacture carbon black is not known, cadmium content in petroleum crude has been reported at 0.03 parts per million by weight (ppmwt).<sup>19</sup> Figure 8-4 contains a flow diagram of this process.

Three primary raw materials used in this process are, preheated feedstock (either the petrochemical oil or carbochemical oil), which is preheated to a temperature between 150°C and 250°C (302°F and 482°F), preheated air, and an auxiliary fuel such as natural gas. A turbulent, high-temperature zone is created in the reactor by combusting the auxiliary fuel, and the preheated oil feedstock is introduced in this zone as an atomized spray. In this zone of the reactor, most of the oxygen would be used to burn the auxiliary fuel, resulting in insufficient oxygen to combust the oil feedstock. Thus, pyrolysis (partial combustion) of the feedstock is achieved, and carbon black is produced. Most of the cadmium present in the feedstock will be emitted as PM in the hot exhaust gas from the reactor.

The product stream from the reactor is quenched with water, and any residual heat in the product stream is used to

8-30

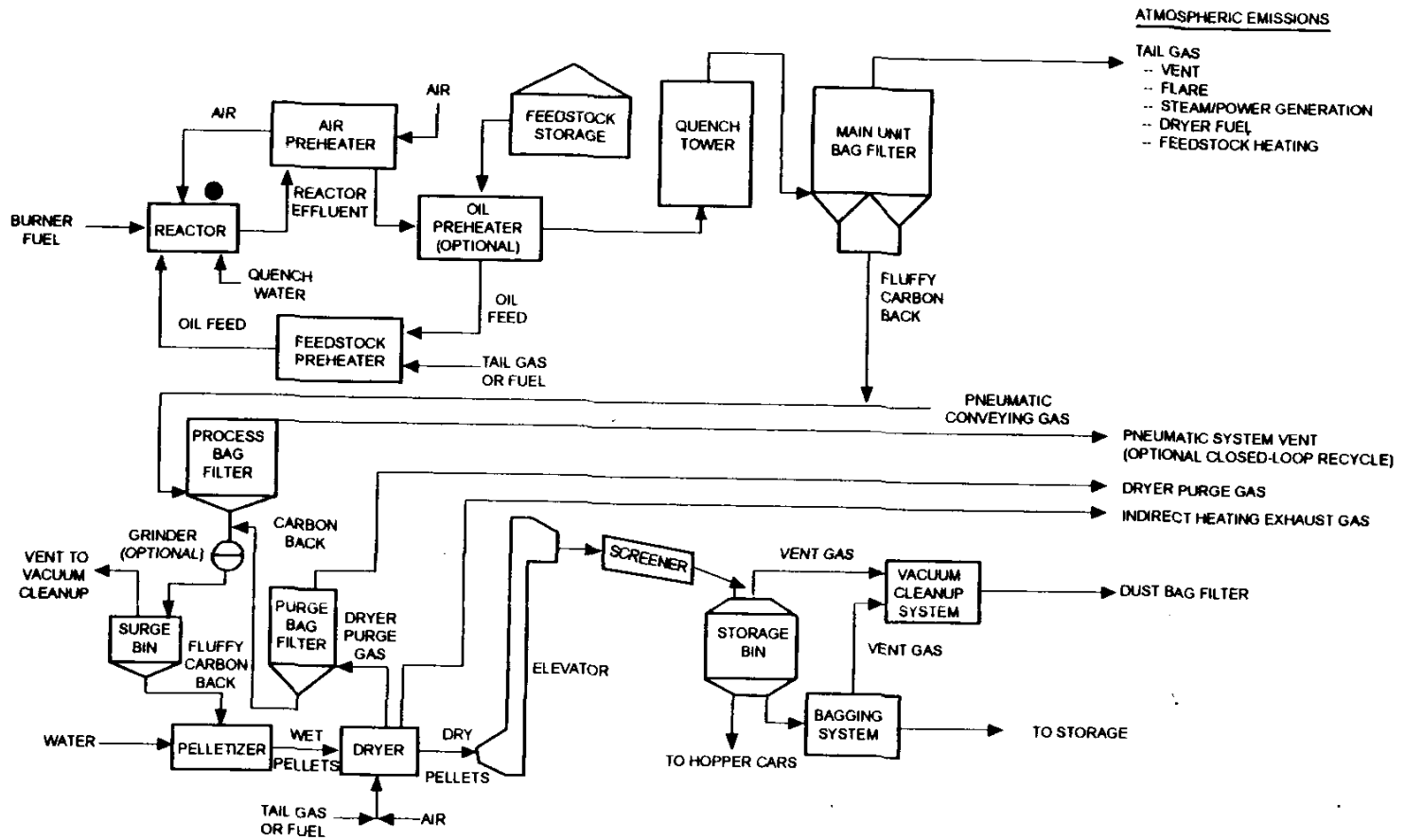

Figure 8-4. Process flow diagram for carbon black manufacturing process. 114

preheat the oil feedstock and combustion air before recovering the carbon in a fabric filter. Carbon recovered in the fabric filter is in a fluffy form. The fluffy carbon black may be ground in a grinder, if desired. Depending on the end use, carbon black may be shipped in a fluffy form or in the form of pellets. Pelletizing is done by a wet process in which carbon black is mixed with water along with a binder and fed into a pelletizer. The pellets are subsequently dried and bagged prior to shipping.

### Emission Control Measures<sup>18</sup>

During the manufacture of carbon black, high-performance fabric filters are used in the oil furnace process to recover additional carbon black; however, they also control PM emissions from main process streams. Fabric filters reportedly can reduce PM emissions to levels as low as 6 mg/m<sup>3</sup> (normal m<sup>3</sup>), and will be used by facilities to optimize their manufacturing performance.

For oil furnaces, a cyclone can be used for particle agglomeration upstream of the fabric filter. A single collection system often serves several manifolded furnaces.

### Emissions

The locations of cadmium particulate emission sources from the oil furnace process are shown by solid circles in Figure 8-4. The greatest release of cadmium occurs during pyrolysis of the feedstock, making the reactor the major emission source during production.

No data are available concerning cadmium emissions from the thermal process. It is also not known how efficiently fabric filters capture cadmium emissions. The only available data are

for emissions from the oil furnace process. These data show cadmium emissions to be less than  $5.0 \times 10^{-5}$  kg/Mg ( $1.0 \times 10^{-4}$  lb/ton) from the main process vent.<sup>19</sup> This data source was a compilation of reported data and not test data; it should be used with caution.

## MOBILE SOURCES

Historically, the major emissions measured and regulated under Title II of the Clean Air Act (CAA) from mobile sources are CO, NO<sub>x</sub>, and hydrocarbons (HC). Emission factors for these specific pollutants among the different motor vehicle classes are compiled in AP-42, Volume II.<sup>21</sup> Gasoline-powered motor, on-road, light-duty vehicles comprise the most significant mobile emission sources because of their large numbers. According to the 1990 Statistical Abstract, 1988 nationwide registrations were estimated to be 183.5 million cars, trucks, and buses. Of that number, 140.7 million were passenger cars and 42.8 million were trucks and buses.<sup>22</sup> As of 1991, the total vehicle miles traveled (VMT) in the United States was 3,457,478 million kilometers (2,147,501 million miles).<sup>23</sup>

Potential cadmium emissions result from trace quantities present in the petroleum crude oil feedstock for fuel and motor oil.<sup>19</sup> Uncontrolled vehicle emissions have declined because catalytic converters and unleaded gasoline are required along with State-regulated inspection and maintenance programs. Therefore, malfunctioning vehicles would be the emission source from cadmium containing fuel or motor oil. Tire wear may also be a source of cadmium emissions if any cadmium is present as an impurity in the finished tire.

A study conducted in 1979 characterized exhaust emissions from noncatalyst- and catalyst-equipped vehicles under malfunctioning conditions.<sup>24</sup> No cadmium was detected in the exhausts. A more recent test was performed in 1989 to characterize exhaust emissions of late model cars for toxic pollutants listed or undergoing review for listing under California's air toxics program.<sup>25</sup> Particulate samples were taken and analyzed for 31 trace metals, including cadmium. Of the 31 trace metals, only 18 were detected in the exhaust; cadmium was among the group of metals that was not detected. The study used x-ray fluorescence for the metals analyses but did not state a detection limit for cadmium. Based on this study, the presence of cadmium in auto exhaust cannot be excluded but may be present at a level below the unspecified detection limit of the analytical method used in the study.

#### REFERENCES

1. Houck, G.W. Iron and Steel. Annual Report: 1991. Bureau of Mines, U.S. Department of the Interior. Washington, DC. December 1992.
2. Trenholm, A.R. Midwest Research Institute. DRAFT Preliminary Description of the Integrated Iron and Steel Industry and of Blast Furnace Basic Oxygen Furnace and Sintering Operations. Emissions Standards Division, Office of Air Quality Planning and Standards, U. S. Environmental Protection Agency, Research Triangle Park, NC. October 1991.
3. U. S. Environmental Protection Agency. Compilation of Air Pollutant Emission Factors - 4th ed., Volume I, Stationary Point and Area Sources. AP-42. Office of Air and Radiation, Office of Air Quality Planning and Standards, U. S. Environmental Protection Agency, Research Triangle Park, NC. 1985.
4. Easterly, W. E. et al. Metallurgical Coke. (In) Air Pollution Engineering Manual. A. J. Buonicore and W. T. Davies, eds. Van Nostrand Reinhold, NY. 1992.

5. Huskonen, W. W. Adding the Final Touches. 33 Metal Producing. 29:28-131. May 1991.
6. Coleman, R. et al. Sources of Atmospheric Cadmium. EPA-450/5-79-006. Office of Air Quality Planning and Standards, U. S. Environmental Protection Agency, Research Triangle Park, NC. August 1979.
7. IT Corporation. Engineering Evaluation of the Charging Machine Hood System at Jewel Coal and Coke Company. Knoxville, TN. December 1992.
8. U. S. Environmental Protection Agency. Electric Arc Furnaces and Argon-Oxygen Decarburization Vessels in Steel Industry-Background Information for Proposed Revisions to Standards. Draft EIS. EPA-450/3-82-020a. Office of Air Quality Planning and Standards, Research Triangle Park, N.C. July 1983.
9. U. S. Environmental Protection Agency. 1990 Toxic Chemical Release Inventory. Office of Toxic Substances. Washington, DC. January 1993.
10. Midwest Research Institute. Portland Cement Manufacturing - AP-42 Update. DRAFT. Technical Support Division, Office of Air Quality Planning and Standards, U. S. Environmental Protection Agency, Research Triangle Park, NC. July 1992.
11. Portland Cement Association. U.S. and Canadian Portland Cement Industry: Plant Information Summary. Portland Cement Association. Skokie, IL. 1990.
12. Mumma, C., K. Bohannon, and F. Hopkins. Chemical Technology and Economics in Environmental Perspectives. Task VI - Cadmium in Phosphate Fertilizer Production. EPA 560/2-77-006. Office of Toxic Substances, U. S. Environmental Protection Agency. Washington, DC. November 1977.
13. Dolan, M. J., and R. B. Hudson. Phosphoric Acid and Phosphates. (In) Kirk-Othmer Concise Encyclopedia of Chemical Technology. M. Grayson and D. Eckroth, eds. A Wiley-Interscience Publication, John Wiley and Sons, New York, NY. 1985.
14. Van Wazer, J. R. Phosphorus and the Phosphides. (In) Kirk-Othmer Concise Encyclopedia of Chemical Technology. M. Grayson and D. Eckroth, eds. A Wiley-Interscience Publication, John Wiley and Sons, New York, NY. 1985.

15. Stowasser, W. F. Phosphate Rock. Annual Report: 1991. Bureau of Mines, U. S. Department of the Interior. Washington, DC. November 1992.
16. SRI International. 1991 Directory of Chemical Producers: United States of America. SRI International, Menlo Park, CA. 1991.
17. GCA Corporation. Survey of Cadmium Emission Sources. EPA 450/3-81-013. Office of Air Quality Planning and Standards, Research Triangle Park, NC. September 1981.
18. Taylor, B. R., Buonicore, A. J., and W. T. Davies, eds. Carbon Black. (In) Air Pollution Engineering Manual. Van Nostrand Reinhold, NY. 1992.
19. Smith, I.C., T. L. Ferguson, and B. L. Carson. Metals in New and Used Petroleum Products. (In) The Role of Trace Metals in Petroleum. T. F. Yeh, ed. Ann Arbor Science Publishers, Ann Arbor, MI. 1975.
20. Serth, R. W., and T. W. Hughes. Polycyclic Organic Matter (POM) and Trace Element Contents of Carbon Black Vent Gas. Environment Science Technology, 14(3): 298-301. 1980.
21. U. S. Environmental Protection Agency. Compilation of Air Pollutant Emission Factors-4th ed., Volume II, Mobile Sources. AP-42. Motor Vehicle Emission Laboratory, Office of Mobile Sources, U. S. Environmental Protection Agency, Ann Arbor, MI. 1985.
22. U. S. Bureau of the Census. Statistical Abstract of the United States: 1990 (110th ed.). Washington, DC. 1990.
23. Telecon. N. Dobie, EPA, Office of Mobile Sources, with T. Campbell, Midwest Research Institute. Highway Statistics on Total Vehicle Miles Traveled in the U.S. in 1990. November 1992.
24. Urban, C.M, and R.J. Garbe. Regulated and Unregulated Exhaust Emissions from Malfunctioning Automobiles. Society of Automotive Engineers, Inc., Technical Paper Series, No. 790696. June 1979.
25. Warner-Selph, M., and J. De Vita. Measurements of Toxic Exhaust Emissions from Gasoline-Powered Light-Duty Vehicles. Society of Automotive Engineers, Inc., Technical Paper Series, No. 892075. September 1989.



## SECTION 9

### SOURCE TEST PROCEDURES

#### INTRODUCTION

A number of methods exist to determine cadmium (Cd) emissions from stationary sources. Several EPA offices and some State agencies have developed source-specific or dedicated sampling methods for Cd. Other industry sampling methods do exist, but none of these methods have been validated and will not be discussed in this section.

Subsequent parts of this section will discuss EPA reference or equivalent sampling methods for Cd. Sampling methods fall into one of two categories: (1) dedicated Cd methods for specific sources or (2) multiple metals sampling trains that include Cd for multiple sources. Each category of methods will be described, differences among the methods will be discussed, and a citation will be provided for more detailed information about the methods.

Sampling methods included in this section were selected from EPA reference methods, equivalent methods, draft methods, or State methods. To be a reference method, a sampling method must undergo a validation process and be published. To qualify as an equivalent method, a sampling method must be demonstrated to the EPA Administrator, under specific conditions, as an acceptable alternative to the normally used reference methods. Also included in this section is a draft method, which is under development.

## MULTIPLE METALS SAMPLING TRAINS

### Method 0012-Methodology for the Determination of Metals Emissions in Exhaust Gases from Hazardous Waste Incineration and Similar Combustion Sources<sup>1</sup>

This method was developed for the determination of a total of 16 metals, including Cd, from stack emissions of hazardous waste incinerators and similar combustion processes. Method 0012 allows for the determination of particulate emissions from these sources. A diagram of a sampling train typical of a multiple metals sampling train is presented in Figure 9-1.

The stack sample is withdrawn isokinetically from the source. Particulate emissions are collected in the probe and on a heated filter; gaseous emissions are collected in a series of four chilled impingers: two contain an aqueous solution of dilute  $\text{HNO}_3$  combined with dilute  $\text{H}_2\text{O}_2$  and two contain acidic  $\text{KMnO}_4$  solution. Sampling train components are recovered and digested in separate front- and back-half fractions. Materials collected in the sampling train are digested with acid solutions using conventional Parr® Bomb, or microwave digestion techniques to dissolve organics and to remove organic constituents that may create analytical interferences. The detection limit for Cd by ICAP is approximately 5 ng Cd/ml.

The corresponding in-stack method detection limit can be calculated by using (1) the procedures described in this method, (2) the analytical detection limits described in the previous paragraph, (3) a volume of 300 ml for the front-half and 150 ml for the back-half samples, and (4) a stack gas sample volume of  $1.25 \text{ m}^3$ :

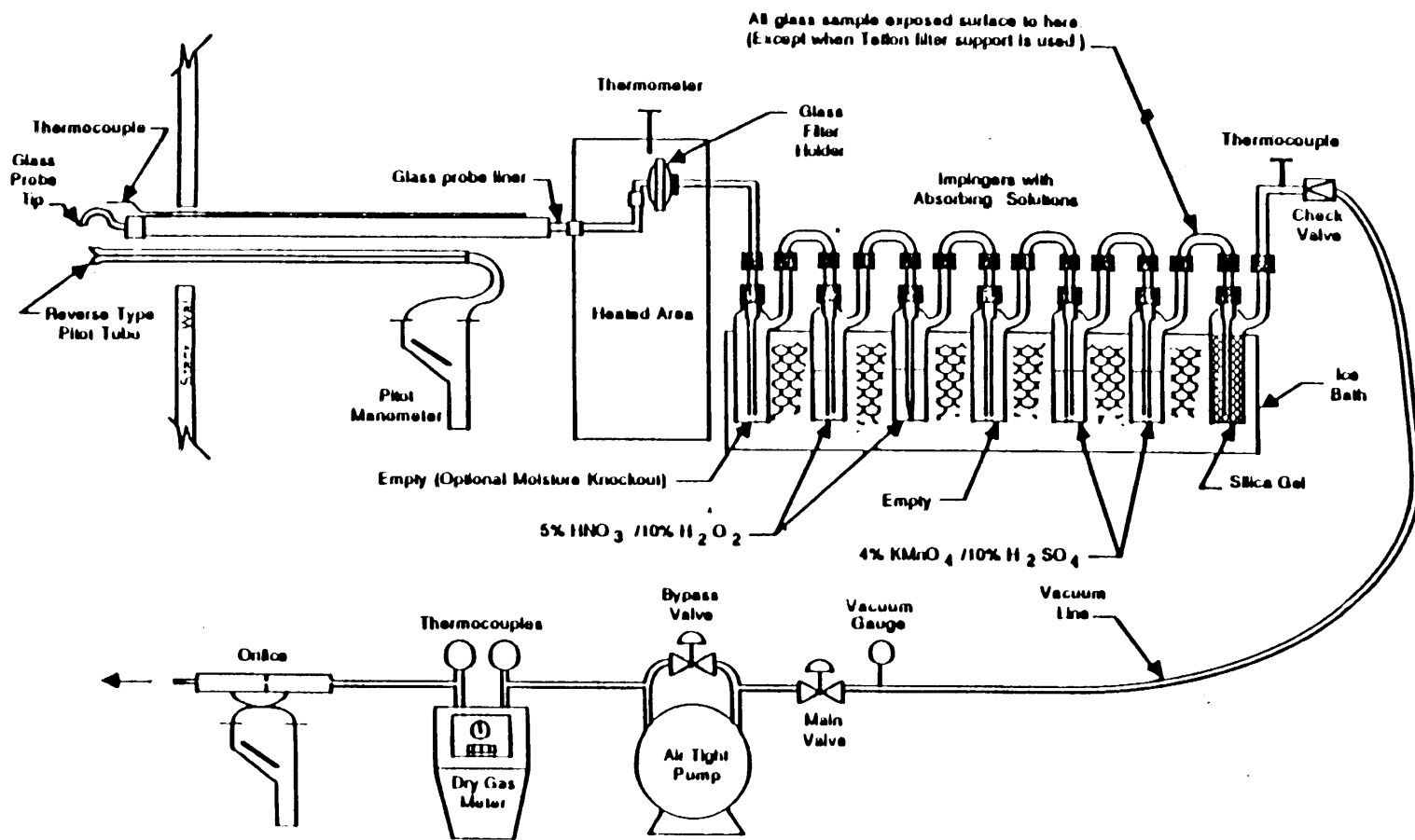

Figure 9-1. Typical multiple metals sampling train.

$$\frac{A \times B}{C} = D$$

where: A = analytical detection limit,  $\mu\text{g Cd/ml}$   
B = volume of sample prior to aliquot for analysis, ml  
C = sample volume, dry standard cubic meter (dscm)  
D = in-stack detection limit,  $\mu\text{g Cd/m}^3$

Methodology for the Determination of Metals Emissions in Exhaust Gases from Hazardous Waste Incineration and Similar Combustion Sources<sup>2</sup>

The method was developed to determine the emissions of the same metals as Method 0012 from hazardous waste incinerators and similar combustion sources. This method is similar to SW-846 Method 0012 in sampling approach and analytical requirements.

CARB Method 436-Determination of Multiple Metals Emissions from Stationary Sources<sup>3</sup>

This method is applicable for determining the emissions of metals, including Cd, from stationary sources. This method is similar to SW-846 Method 0012 in sampling approach and analytical requirements. Method 436 suggests that the concentrations of target metals in the analytical solutions be at least 10 times the analytical detection limits. This method may be used in lieu of Air Resource Board Methods 12, 101, 104, 423, 424, and 433.

EPA Method 29-Methodology for the Determination of Metals Emissions in Exhaust Gases from Incineration and Similar Combustion Sources (Draft)<sup>4</sup>

This method is applicable for determining the emissions of metals, including Cd, from stationary sources. This method is similar to SW-846 Method 0012 in sampling approach and analytical requirements.

ANALYTICAL METHODS FOR DETERMINATION OF CADMIUM

This section contains brief overview descriptions of the five analytical techniques generally used for trace metal determinations: (1) inductively coupled argon plasma emission spectrometry (ICAP), (2) direct-aspiration or flame atomic absorption spectrometry (FAA), (3) graphite-furnace atomic absorption spectrometry (GFAA), (4) hydride-generation atomic absorption spectrometry (HGAA), and (5) cold-vapor atomic absorption spectrometry (CVAA). Each technique is discussed below in terms of advantages, disadvantages, and cautions for analysis.

The primary advantage of ICAP is that it allows simultaneous or rapid sequential determination of many elements in a short time. The primary disadvantage of ICAP is background radiation from other elements and the plasma gases. Although all ICAP instruments utilize high-resolution optics and background correction to minimize these interferences, analysis for traces of metals in the presence of a large excess of a single metal is difficult. An example would be traces of metals in an alloy or traces of a metal in a limed (high calcium) waste. ICAP and Flame AA have comparable detection limits (within a factor of 4), except that ICAP exhibits greater sensitivity for refractories (Al, Ba, etc.).

Flame AAS (FAA) determinations, as opposed to ICAP, are normally completed as single element analyses and are relatively free of interelement spectral interferences. Either a nitrous-oxide/acetylene or air/acetylene flame is used as an energy source for dissociating the aspirated sample into the free atomic state, making analyte atoms available for absorption of light. In the analysis of some elements, the temperature and type of flame used is critical. If the proper flame and analytical conditions are not used, chemical and ionization interferences can occur.

Graphite Furnace AAS (GFAA) replaces the flame with an electrically heated graphite furnace. The furnace allows for gradual heating of the sample aliquot in several stages. Thus, the processes of desolvation, drying decomposition for organic and inorganic molecules and salts, and formation of atoms (which must occur in a flame or ICAP in a few milliseconds) may be allowed to occur over a much longer time period and at controlled temperatures in the furnace. This allows the removal of unwanted matrix components by using temperature programming and/or matrix modifiers. The major advantage of this technique is that it affords extremely low detection limits. It is the easiest technique to perform on relatively clean samples. Because this technique is so sensitive, interferences can be a problem; finding the optimum combination of digestion, heating times and temperatures, and matrix modifiers can be difficult for complex matrices. Furnace AA, in general, will exhibit lower detection limits than either ICAP or flame AAS.

Hydride AA (HGAA) utilizes a chemical reduction to reduce and separate arsenic or selenium selectively from a sample digestate. The technique, therefore, has the advantage of being able to isolate these two elements from complex samples, which may cause interferences for the analytical procedures.

Significant interferences have been reported when any of the following is present: (1) easily reduced metals (Cu, Ag, Hg), (2) high concentrations of transition metals (>200 mg/L), and (3) oxidizing agents (oxides of nitrogen) that remain following sample digestion.

Cold-Vapor AA (CVAA) uses a chemical reduction to selectively reduce Hg. The procedure is extremely sensitive but is subject to interferences from some volatile organics, chlorine, and sulfur compounds.

#### SUMMARY

All of the above source sampling methods collect a sample for analysis of multiple metals, including Cd. Significant criteria and characteristics of each method are presented in Table 9-1. This table is a summary of information presented in various methods. The major differences between the methods involve: (1) the type of impinger solutions, (2) the amount or concentration of impinger solutions, (3) the sequence and types of sample train recovery solutions, and (4) the use and/or type of particulate filter.

In assessing Cd emissions from test reports, the age or revision number of the method indicates the level of precision and accuracy of the method. Older methods are sometimes less precise or accurate than those that have undergone more extensive validation. Currently, EPA Method 301 from 40 CFR Part 63, Appendix A can be used to validate or prove the equivalency of new methods.

TABLE 9-1. CADMIUM SAMPLING METHODS

| Method            | Filter                   | Impinger  | Range               | Chemical interference    | Detection limit       |
|-------------------|--------------------------|---|---------------------|--------------------------|-----------------------|
| EPA 29<br>(Draft) | Quartz or glass<br>fiber | 1 X empty (optional)<br>2 X HNO <sub>3</sub> /H <sub>2</sub> O <sub>2</sub><br>1 X empty<br>2 X KMnO <sub>4</sub> /H <sub>2</sub> SO <sub>4</sub><br>1 X silica gel | ngCd/ml to µg Cd/ml | Excessive chloride, iron | 5 ng Cd/ml            |
| SW-846 0012       | Quartz or glass<br>fiber | 1 X empty (optional)<br>2 X HNO <sub>3</sub> /H <sub>2</sub> O <sub>2</sub><br>1 X empty<br>2 X KMnO <sub>4</sub> /H <sub>2</sub> SO <sub>4</sub><br>1 X silica gel | ngCd/ml to µg Cd/ml | Excessive chloride, iron | 4 ng Cd/ml<br>by ICAP |
| OSW-BIF           | Quartz or glass<br>fiber | 1 X empty<br>2 X HNO <sub>3</sub> /H <sub>2</sub> O <sub>2</sub><br>1 X empty<br>2 X KMnO <sub>4</sub> /H <sub>2</sub> SO <sub>4</sub><br>1 X silica gel            | ngCd/ml to µg Cd/ml | Excessive chloride       | 5 ng Cd/ml            |
| CARB 436          | Quartz or glass<br>fiber | 1 X empty<br>2 X HNO <sub>3</sub> /H <sub>2</sub> O <sub>2</sub><br>2 X KMnO <sub>4</sub> /H <sub>2</sub> SO <sub>4</sub><br>1 X silica gel                         | ngCd/ml to µg Cd/ml | Excessive chloride       | 5 ng Cd/ml            |



## REFERENCES

1. EPA Method 0012, Methodology for the Determination of Metals Emissions in Exhaust Gases from Hazardous Waste Incineration and Similar Combustion Sources, Test Methods for Evaluating Solid Waste: Physical/Chemical Methods. SW-846, Third Edition. Office of Solid Waste and Emergency Response, U. S. Environmental Protection Agency, Washington, DC. September 1988.
2. Methodology for the Determination of Metals Emissions in Exhaust Gases from Hazardous Waste Incineration and Similar Combustion Sources, Methods Manual for Compliance with the BIF Regulations Burning Hazardous Waste in Boilers and Industrial Furnaces. EPA/530-SW-91-010. Office of Solid Waste and Emergency Response, U. S. Environmental Protection Agency, Washington, DC. December 1990.
3. CARB Method 436, Determination of Multiple Metals Emissions from Stationary Sources. State of California Air Resources Board, Sacramento, CA.
4. EPA Method 29. Methodology for the Determination of Metals Emissions in Exhaust Gases from Incinerations and Similar Combustion Sources (Draft). 40 Code of Federal Regulations, Part 60, Appendix A. Washington, DC. 1992.

APPENDIX A  
NATIONWIDE EMISSION ESTIMATES

## EMISSIONS FROM CADMIUM PRODUCTION

### Cadmium Refining

#### Basis of Input Data

1. The 1990 TRI reported emissions for all producers of cadmium (see Table 4-3) to be 4.2 Mg (4.6 tons).
2. Emissions reported in the TRI may give abnormally high values because the TRI data may include unusual and accidental releases. However, in the absence of other data, the nationwide estimates will be based on these data.

### Cadmium Pigments Production

#### Basis of Input Data

1. The emissions reported in the 1990 TRI for producers of inorganic pigments were 1.6 Mg (1.8 tons). These data are presented in Table 4-8.
2. Emissions reported in the TRI may give abnormally high values because the TRI data may include unusual and accidental releases. However, in the absence of other data, the nationwide estimates will be based on these data.

### Cadmium Stabilizers Production

No emission factors are available for cadmium emissions from this source.

### Other Cadmium Compound Production

No emission factors are available for cadmium emissions from this source.

## EMISSIONS FROM MAJOR USES OF CADMIUM

### Secondary Battery Manufacture

#### Basis of Input Data

1. The 1990 TRI reported emissions for all manufacturers of secondary cadmium batteries to be 0.32 Mg (0.35 tons).
2. Emissions reported in the TRI may give abnormally high values because the TRI data may include abnormal and accidental releases. However, in the absence of other data, the nationwide emissions presented in Section 3 are based on the 1990 TRI report.

## EMISSIONS FROM COMBUSTION SOURCES

### Coal Combustion

#### Coal-Fired Utility Boilers--

##### Basis of Input Data

1. From Table 6-8, emission factor for bituminous coal combustion =  $3.0 \times 10^{-14}$  kg/J and for anthracite coal combustion =  $7.3 \times 10^{-15}$  kg/J.
2. Bituminous coal combustion systems controlled by ESP's with an average cadmium control efficiency of 75 percent.
3. Anthracite coal combustion systems uncontrolled.
4. Energy from coal combustion in utility sector from Table 6-1.

##### Calculations

$$\begin{aligned} \text{Annual Emissions} &= 3.0 \times 10^{-14} \text{ kg/J} * 16.939 \times 10^{18} \text{ J/yr} * \\ &\quad 0.25 \\ &\quad + 7.3 \times 10^{-15} \text{ kg/J} * 0.018 \times 10^{18} \text{ J/yr} \\ &= 128.37 \text{ Mg/yr} = 141.51 \text{ tons/yr} \end{aligned}$$

#### Coal-Fired Industrial Boilers--

##### Basis of Input Data

1. From Table 6-8, emission factor for bituminous coal combustion =  $3.0 \times 10^{-14}$  kg/J and for anthracite coal combustion =  $7.3 \times 10^{-15}$  kg/J
2. No control of emissions from industrial boilers was assumed.
3. Energy from coal combustion in industrial sector from Table 6-1.

##### Calculations

$$\begin{aligned} \text{Annual Emissions} &= 3.0 \times 10^{-14} \text{ kg/J} * 2.892 \times 10^{18} \text{ J/yr} \\ &\quad + 7.3 \times 10^{-15} \text{ kg/J} * 0.009 \times 10^{18} \text{ J/yr} \\ &= 87.64 \text{ Mg/yr} = 96.61 \text{ ton/yr} \end{aligned}$$

#### Coal-Fired Commercial and Residential Boilers- -

Basis of Input Data

1. From Table 6-8, emission factor for bituminous coal combustion =  $3.0 \times 10^{-14}$  kg/J and for anthracite coal combustion =  $7.3 \times 10^{-15}$  kg/J
2. No control of emissions from industrial boilers was assumed.
3. Energy from coal combustion in commercial/residential sectors from Table 6-1.

Calculations

$$\begin{aligned} \text{Annual Emissions} &= 3.0 \times 10^{-14} \text{kg/J} * 0.130 \times 10^{18} \text{ J/yr} \\ &\quad + 7.3 \times 10^{-15} \text{kg/J} * 0.032 \times 10^{18} \text{J/yr} \\ &= 4.17 \text{ Mg/yr} = 4.60 \text{ tons/yr} \end{aligned}$$

Oil-Fired Utility Boilers--

Basis of Input Data

1. From Table 6-15, emission factor for distillate oil combustion =  $4.7 \times 10^{-15}$  kg/J and for residual oil combustion =  $7.1 \times 10^{-15}$  kg/J
2. Air pollution control measures assumed to provide no cadmium emission reduction.
3. Energy consumption from fuel oil combustion from Table 6-1.

Calculations

$$\begin{aligned} \text{Annual Emissions} &= 4.7 \times 10^{-15} \text{ kg/J} * 1.201 \times 10^{18} \text{ J/yr} \\ &\quad + 7.1 \times 10^{-15} \text{ kg/J} * 0.091 \times 10^{18} \text{ J/yr} \\ &= 6.24 \text{ Mg/yr} = 6.88 \text{ tons/yr} \end{aligned}$$

Oil-Fired Industrial Boilers--

Basis of Input Data

1. From Table 6-15, emission factor for distillate oil combustion =  $4.7 \times 10^{-15}$  kg/J and for residual oil combustion =  $7.1 \times 10^{-15}$  kg/J
2. Air pollution control measures assumed to provide no cadmium emission reduction.
3. Energy consumption from fuel oil combustion from

Table 6-1.

Calculations

$$\begin{aligned} \text{Annual Emissions} &= 4.7 \times 10^{-15} \text{ kg/J} * 1.245 \times 10^{18} \text{ J/yr} \\ &+ 7.1 \times 10^{-15} \text{ kg/J} * 0.436 \times 10^{18} \text{ J/yr} \\ &= 8.91 \text{ Mg/yr} = 9.82 \text{ tons/yr} \end{aligned}$$

Oil-Fired Commercial/Residential Boilers--

Basis of Input Data

1. From Table 6-15, emission factor for distillate oil combustion =  $4.7 \times 10^{-15}$  kg/J and for residual oil combustion =  $7.1 \times 10^{-15}$  kg/J
2. Air pollution control measures assumed to provide no cadmium emission reduction.
3. Energy consumption from fuel oil combustion from Table 6-1.

Calculations

$$\begin{aligned} \text{Annual Emissions} &= 4.7 \times 10^{-15} \text{ kg/J} * 1.395 * 10^{18} \text{ J/yr} \\ &+ 7.1 \times 10^{-15} \text{ kg/J} * 0.255 \times 10^{18} \text{ J/yr} \\ &= 8.31 \text{ Mg} = 9.16 \text{ tons/yr} \end{aligned}$$

Wood Combustion in Boilers--

Basis of Input Data

1. Wood combustion rate in boilers is  $1.0 \times 10^{11}$  Btu/hr, which is the same rate as 1980 given on p. 6-35. Boilers assumed to operate at capacity, 8,760 hr/yr.
2. Heating value of wood is 4,500 Btu/lb based on midpoint of range presented on p. 6-35.
3. Emission factor of  $8.5 \times 10^{-6}$  lb/ton of wood burned.
4. No data available on control of cadmium emissions from wood waste boilers.

Calculations

Annual Emissions

$$= \frac{1.0 \times 10^{11} \text{ Btu/hr} * 8,760 \text{ hr/yr} * 8.5 \times 10^{-6} \text{ lb/tons wood}}{4,500 \text{ Btu/lb} * 2,000 \text{ lb wood/ton wood} * 2,000 \text{ lb Hg/ton Hg}}$$

$$= 0.41 \text{ ton/yr} = 0.38 \text{ Mg/yr}$$

Municipal Waste Combustors--

Basis of Input Data

1. The emission factors for uncontrolled systems contained in Table 6-19 were averaged to obtain the following "typical" emission factors:

Mass Burn - 5.3 g/Mg  
 Modular - 1.2 g/Mg  
 RDF - 4.4 g/Mg

2. Electrostatic precipitators achieve 95 percent removal. Spray dryer systems combined with fabric filters or ESP's achieve 99 and 98 percent removal, respectively. Duct sorbent injection systems combined with fabric filters or ESP's achieve 99 and 95 percent removal, respectively. Based on results for other combustion sources, wet scrubber systems achieve about 75 percent removal.
3. The 1990 MWC processing rates are assumed to be equal to those presented in Waste Age, November 1991, and tabulated in the calculation table below.<sup>1</sup>

Calculations

Controlled Emissions

Annual Emissions

$$= \text{Process Rate} * \text{Emission Factor} * \frac{(100 - \text{Efficiency})}{100}$$

The calculated emissions are tabulated below:



| Combustor type | Control status <sup>a</sup> | Process rate, 10 <sup>6</sup> Mg/yr | Emission factor, g/Mg | Control efficiency, % | Annual Emissions |        |
|----------------|-----------------------------|-------------------------------------|-----------------------|-----------------------|------------------|--------|
|                |                             |                                     |                       |                       | Mg/yr            | ton/yr |
| Mass Burn      | SD/FF                       | 7.190                               | 5.26                  | 99                    | 0.38             | 0.42   |
| Mass Burn      | SD/ESP                      | 7.190                               | 5.26                  | 98                    | 0.76             | 0.83   |
| Mass Burn      | DSI/FF                      | 1.077                               | 5.26                  | 99                    | 0.06             | 0.06   |
| Mass Burn      | DSI/ESP                     | 1.077                               | 5.26                  | 95                    | 0.28             | 0.31   |
| Mass Burn      | ESP                         | 13.806                              | 5.26                  | 95                    | 3.63             | 4.00   |
| Mass Burn      | U                           | 0.517                               | 5.26                  | 0                     | 2.72             | 3.00   |
| RDF            | SD/FF                       | 2.809                               | 4.37                  | 99                    | 0.12             | 0.14   |
| RDF            | SD/ESP                      | 2.809                               | 4.37                  | 98                    | 0.25             | 0.27   |
| Modular        | WS                          | 0.630                               | 1.21                  | 75                    | 0.19             | 0.21   |
| Total          |                             |                                     |                       |                       | 8.39             | 9.24   |

- <sup>a</sup> SD = Spray dryer  
FF = Fabric filter  
ESP = Electrostatic precipitator  
DSI = Duct sorbent injection  
WS = Wet scrubber  
U = Uncontrolled

Sewage Sludge Incinerators --

Basis for Input Data

1. Total sludge processed annually is  $1.5 \times 10^6$  Mg (see p. 6-51)
2. From Table 6-20, the best "typical" uncontrolled emission factor is 26 g/Mg.
3. Most units are controlled by either a venturi or impingement scrubber and average nationwide efficiency is 75 percent.

Calculations

$$\begin{aligned} \text{Annual Emissions} &= 26 \text{ g/Mg} * 1.5 \times 10^6 \text{ Mg/yr} (1-0.75) \\ &= 9.89 \text{ Mg/yr} = 10.91 \text{ tons/yr} \end{aligned}$$

Medical Waste Incinerators --

Basis of Input Data

1. From unpublished data contained in the medical waste incinerator NSPS background files, annual process rates are  $0.204 \times 10^6$  Mg/yr for pathological waste and  $1.431 \times 10^6$  Mg/yr for mixed medical waste.

2. From Table 6-23 "typical" uncontrolled emission factors are 2.5 g/Mg for mixed waste and 0.18 g/Mg for pathological waste.
3. From unpublished data in the medical waste incinerator NSPS background files, approximately 3 percent of the MWI's firing mixed wastes are equipped with pollution control devices. Approximately 45 percent of the controlled MWI's are equipped with dry scrubbers and approximately 55 percent with wet scrubbers. Dry systems can achieve at least 97 percent control while wet systems can achieve about 38 percent control.

### Calculations

#### Annual Emissions

$$\begin{aligned}
 & 2.5 \text{ g/Mg} * 1.43 \times 10^6 \text{ Mg/yr} * 0.97 \\
 + & 2.5 \text{ g/Mg} * 1.43 \times 10^6 \text{ Mg/yr} * 0.03 * 0.45 * (1-0.97) \\
 & 2.5 \text{ g/Mg} * 1.43 \times 10^6 \text{ Mg/yr} * (0.03 * 0.55 * (1-0.38)) \\
 + & 0.18 \text{ g/Mg} * 0.204 \times 10^6 \text{ Mg/yr} \\
 = & 3.55 \text{ Mg/yr} = 3.91 \text{ tons/yr}
 \end{aligned}$$

### EMISSIONS FROM NONFERROUS SMELTING OPERATIONS

1. Primary lead smelting

#### Basis of Input Data

Data in 1990 Toxic Release Inventory (TRI) System. There are 3 primary lead smelting facilities within the U.S. All 3 facilities reported cadmium emissions resulting from all operations for the year 1990. These data are presented in Table 7-2. Accuracy of these data cannot be verified. Therefore, the sum of the cadmium emissions for all 3 facilities will also be the estimated nationwide cadmium emission rate.

#### Calculations

The sum of the cadmium emissions (for both, nonpoint and point sources) for all 3 facilities is 14.3 Mg (15.80 tons), which is also the estimated nationwide annual emission rate of cadmium from primary lead smelting facilities.

2. Primary Copper Smelting

#### Basis of Input Data

Data in 1990 TRI. Four facilities reported total facilitywide cadmium emission rates for 1990. These data are presented in Table 7-5.

#### Calculations

Four facilities reported cadmium emission rates for 1990 as required under Superfund Amendments and Reauthorization Act (SARA) Title III provisions. The sum of the cadmium emission rates reported by the 4 facilities is 5.6 Mg (6.2 tons).

### 3. Primary Zinc Smelting

#### Basis of Input Data

Data in 1990 Toxic Release Inventory System (TRIS). There are 4 primary zinc smelting facilities within the U.S. All 4 facilities reported cadmium emissions resulting from all operations for the year 1990. These data are presented in Table 7-8. Accuracy of these data cannot be verified. Therefore, the sum of the cadmium emissions for all 4 facilities will be the estimated nationwide cadmium emission rate.

#### Calculations

The sum of the cadmium emissions (for both, nonpoint and point sources) for all 4 facilities is 5.7 Mg (6.3 tons), which is also the estimated nationwide annual emission rate of cadmium from primary zinc smelting facilities.

### 4. Secondary Copper Smelting

#### Basis of Input Data

Data in 1989 and 1990 TRI. Three facilities reported total facilitywide cadmium emission rates for 1990. One facility reported cadmium emission data for 1989. These data are presented in Table 7-11.

#### Calculations

The TRI data base contains emissions reported for 1990 by 3 facilities. Another facility (Southwire Co.) reported data for 1989. For this study, it is assumed that the cadmium emissions at Southwire Co. for 1990 was the same as that reported for 1989.

There are a total of 6 secondary copper manufacturing facilities in the U.S. Raw materials used at these

facilities can vary significantly. Therefore, it is not valid to assume that the cadmium emission rate is directly proportional to the plant capacity. This is confirmed by the fact that the cadmium emission factors (see Table below) for the 4 facilities range between  $4.1 \times 10^{-5}$  and 0.028 kg/Mg of product.

---

| Facility                     | Cadmium emission factor (kg/Mg) |
|------------------------------|---------------------------------|
| Cerro Copper Products        | 0.0097                          |
| Franklin Smelting & Refining | 0.028                           |
| Gaston Recycling Inds.       | $4.1 \times 10^{-5}$            |
| Southwire Co.                | $5.43 \times 10^{-4}$           |

---

The cadmium emission factors reported above have been estimated using the TRI data in Table 7-11 and plant capacity data contained in Table 7-10.

Cadmium emission factors are not available to separately estimate the emission rates at the 2 facilities for which there are no TRI data. Therefore, it is conservatively assumed that the emission factor of 0.028 kg/Mg estimated for Franklin Smelting & Refining Co. may be applicable for estimating cadmium emissions at the remaining 2 facilities. This approach is conservative because the emission factor chosen is the highest of the 4 factors estimated above. Based on this emission factor and the capacities given in Table 7-10, the total cadmium emission rate for the 2 facilities is estimated to be 5.0 Mg (5.5 tons). Thus, the nationwide annual cadmium emission rate for all 6 facilities is estimated to be 10.8 Mg (11.9 tons).

5. Secondary Zinc Recovery from Metallic Scrap

Basis of Input Data

1. Cadmium emission factors from SPECIATE data base given in Table 7-13.
2. Figure 7-6 containing the process flow diagram.

Calculations

Major process steps are pretreatment of scrap, melting the sweated scrap and refining/alloying. Each of these steps can be performed in various ways. Because the specific process description for each of the 13 plants listed in Table 7-12 is not known, we need to create a conservative model process flow scheme.

Refer to Figure 7-6. For this study, assume that all plants produce secondary zinc from die cast products, residue skimmings, and other mixed scraps. Pretreatment of these materials is carried out in one of 4 ways as shown in Figure 7-6. Of the 4 cadmium emission factors corresponding to these 4 pretreatment methods, the emissions factor for reverberatory sweat furnace (general metallic scrap) is the highest. This emission factor is 0.01232 kg/Mg of zinc produced. Therefore, it is assumed that all 13 plants use the reverberatory sweat furnace for pretreatment.

Next, the melting is carried out in one of 4 ways. However, Table 7-13 does not contain cadmium emission factors for melting operations. Therefore, it is assumed that all 13 plants also carry out the melting in reverberatory melting kettles and the cadmium emission factor for melting is the same as that for pretreatment (0.01232 kg/Mg of zinc produced).

Finally, zinc ingot is produced in one of 2 ways. The cadmium emission factor for both methods is reported to be 0.00091 kg/Mg.

Therefore, the total cadmium emission factor for the three major processing steps is estimated to be 0.02555 kg/Mg of zinc produced. The total zinc production capacity for all 13 plants is reported to be 58,000 Mg. Therefore, the nationwide annual cadmium emission rate for all 13 plants resulting from the major processing steps is estimated to be 1.5 Mg (1.7 tons).

## 6. Secondary Zinc Recovery from EAF Dust

### Basis of Input Data

Cadmium emission factor data for recovery of zinc from EAF dust are limited. Cadmium emission factor for only one processing step using the flame reactor is available. The emission factor is reported to be  $2.1 \times 10^{-4}$  kg/Mg of EAF dust processed. Therefore, for this study, it is assumed that all facilities producing zinc from EAF dust use the flame reactor.

## Calculations

Table 7-14 presents the EAF dust processing capacity for all 9 facilities in the U.S. The total EAF dust processing capacity is 533,200 Mg/yr. If all this dust is processed in a flame reactor equipped with a fabric filter, the nationwide annual cadmium emission rate resulting from this processing step is estimated to be 112 kg (246 lb). It must be noted that other major processing step, the calcining kiln, will also emit cadmium. However, the cadmium emission rate corresponding to this step cannot be estimated due to the lack of emission factor data.

### EMISSIONS FROM MISCELLANEOUS SOURCES

#### Iron and Steel Production

The available data are insufficient to permit the calculation of emission estimates.

#### Portland Cement Production

##### Basis of Input Data

1. The 1990 total production of cement was  $70.6 \times 10^6$  Mg ( $77.8 \times 10^6$  tons) of which 95.7 percent was Portland cement. Total production of Portland cement was  $67.5 \times 10^6$  Mg ( $74.5 \times 10^6$  tons).
2. Cadmium emission factors for selected processes in both dry process kilns and wet process kilns were presented in Table 8-5. These emission factors are based on quantity of raw material feed.
3. Based on data in test reports, the following average conversions were obtained for raw material quantities to clinker quantities:  

|              |                                     |
|--------------|-------------------------------------|
| wet process: | 1.7 Mg (1.87 tons) of feed produces |
|              | 1.0 Mg (1.1 tons) of clinker        |
| dry process: | 1.6 Mg (1.76 tons) of feed produces |
|              | 1.0 Mg (1.1 tons) of clinker        |
4. Based on the two processes, cadmium emissions from a dry process kiln, including preheater/precalciner, are not anticipated to be any less than emissions from the wet process. Therefore, the emission factors in Table 8-5 are used for all Portland cement produced.

### Calculations

Annual emissions from raw mill - air separator:

$$6.75 \times 10^6 \text{ Mg} * 1.6 * 4.43 \times 10^{-7} \text{ kg/Mg} = 47.8 \text{ kg/yr} \\ = 0.048 \text{ Mg/yr}$$

Annual emissions from finishing mill - weigh hopper:

$$67.5 \times 10^6 \text{ Mg} * 1.6 * 7.56 \times 10^{-7} \text{ kg/Mg} \\ = 81.6 \text{ kg/yr} = 0.082 \text{ Mg/yr}$$

Annual emissions from finishing mill - air separator:

$$67.5 \times 10^6 \text{ Mg} * 1.6 * 1.30 \times 10^{-6} \text{ kg/Mg} = 140 \text{ kg/yr} \\ = 0.14 \text{ Mg/yr}$$

Annual emissions from clinker cooler:

$$67.5 \times 10^6 \text{ Mg} * 1.6 * 8.7 \times 10^{-6} \text{ kg/Mg} = 940 \text{ kg/yr} \\ = 0.94 \text{ Mg/yr}$$

Annual emissions from wet rotary kiln:

$$67.5 \times 10^6 \text{ Mg} * 1.6 * 1.1 \times 10^{-4} \text{ kg/Mg} = 11.9 \text{ Mg/yr}$$

Total annual emissions:

$$0.048 \text{ Mg/yr} + 0.082 \text{ Mg/yr} + 0.14 \text{ Mg/yr} + 0.94 \text{ Mg/yr} + \\ 11.9 \text{ Mg/yr} = 13.1 \text{ Mg/yr} = 14.4 \text{ tons/yr}$$

### Phosphate Rock Processing

No emission factors are available for cadmium emissions from this source.

### Carbon Black Production

#### Basis of Input Data

1. The 1990 total capacity for carbon black production was  $1.47 \times 10^6$  Mg ( $1.62 \times 10^6$  tons).<sup>2</sup> No data were available for actual production of carbon black in 1990.
2. An emission factor of  $5 \times 10^{-5}$  kg of Cd/Mg of carbon black ( $1 \times 10^{-4}$  lb/ton) is used.<sup>3</sup>

3. The emission factor is based only on the oil-furnace process which accounts for 99 percent of all carbon black production.
4. Cadmium emissions are based on production capacity and not actual production. Use of actual production data would show a lower value for cadmium emissions.

#### Calculations

$$\begin{aligned} \text{Annual emissions} &= 5 \times 10^{-5} \text{ kg/Mg} * 1.47 \times 10^6 \text{ Mg} = \\ &0.07 \text{ Mg/yr} = 0.08 \text{ ton/yr} \end{aligned}$$

#### Mobile Sources

No emission factors are available for cadmium emissions from this source.

#### REFERENCES FOR APPENDIX A

1. Kiser, J. V. L., and D. B. Sussman, Municipal Waste Combustion and Mercury: The Real Story. Waste Age, November 1991, Pp. 41-44.
2. SRI International. 1991 Directory of Chemical Producers: United States of America. SRI International, Menlo Park, California. 1991.
3. Serth, R. W., and T. W. Hughes. Polycyclic Organic Matter (POM) and Trace Element Contents of Carbon Black Vent Gas. Environ. Sci. Technol., 14(3): 298-301. 1980.



APPENDIX B

SUMMARY OF COMBUSTION SOURCE CADMIUM EMISSION DATA

TABLE B-1. SUMMARY OF COAL COMBUSTION EMISSION DATA

| Industry sector <sup>a</sup> | Facility type <sup>b</sup> | Control status <sup>c</sup> | Coal type <sup>d</sup> | Emission factor       |            |                         |           |
|------------------------------|----------------------------|-----------------------------|------------------------|-----------------------|------------|-------------------------|-----------|
|                              |                            |                             |                        | kg/10 <sup>15</sup> J |            | lb/10 <sup>12</sup> Btu |           |
|                              |                            |                             |                        | Mean                  | Range      | Mean                    | Range     |
| U                            | PC/DB                      | ESP                         | B                      | 1.1                   | --         | 2.6                     | --        |
| U                            | PC/DB                      | WS                          | B                      | 0.52                  | --         | 1.2                     | --        |
| U                            | PC/DB                      | MP/ESP                      | B                      | 0.82                  | --         | 1.9                     | --        |
| U                            | PC/DB                      | MP/ESP                      | B                      | 0.60                  | --         | 1.4                     | --        |
| U                            | PC/DB                      | ESP                         | B                      | 11                    | 4.9-23     | 26                      | 11-53     |
| U                            | PC/DB                      | UN                          | B                      | 59                    | 49-72      | 140                     | 110-170   |
| U                            | PC/DB                      | ESP                         | B                      | 2.8                   | --         | 6.6                     | --        |
| U                            | PC/DB                      | ESP                         | B                      | 4.2                   | --         | 9.8                     | --        |
| U                            | PC/DB                      | ESP                         | B                      | 1.6                   | --         | 3.8                     | --        |
| U                            | PC/DB                      | UN                          | B                      | 18                    | --         | 41                      | --        |
| U                            | PC/DB                      | UN                          | B                      | 5.2                   | --         | 12                      | --        |
| U                            | PC/DB                      | UN                          | B                      | 4.7                   | --         | 11                      | --        |
| U                            | PC/DB                      | ESP                         | B                      | 1.9                   | --         | 4.5                     | --        |
| U                            | PC/DB                      | ESP                         | B                      | 3.1                   | --         | 7.1                     | --        |
| U                            | PC/DB                      | UN                          | B                      | 4.3                   | --         | 10                      | --        |
| U                            | PC/DB                      | UN                          | B                      | 4.0                   | --         | 9.2                     | --        |
| U                            | PC/DB                      | UN                          | B                      | --                    | 4.3-6.0    | --                      | 10-14     |
| U                            | PC/DB                      | ESP                         | B                      | <2.0                  | --         | <4.6                    | --        |
| U                            | PC/DB                      | ESP/WS                      | B                      | <2.0                  | --         | <4.6                    | --        |
| U                            | PC/DB                      | MP                          | B                      | 130                   | 59-210     | 290                     | 140-490   |
| U                            | PC/DB                      | MP/ESP                      | B                      | 20                    | --         | 46                      | --        |
| U                            | PC/DB                      | VS                          | B                      | 0.84                  | --         | 2.0                     | --        |
| U                            | PC/DB                      | ESP                         | B                      | --                    | 0.095-0.26 | --                      | 0.22-0.60 |
| U                            | PC/DB                      | MP                          | B                      | 13                    | 6.5-24     | 31                      | 15-56     |
| U                            | PC/DB                      | UN                          | B                      | 18                    | 10-32      | 42                      | 24-74     |
| U                            | PC/WB                      | MP/ESP                      | B                      | 0.82                  | --         | 1.9                     | --        |
| U                            | PC/WB                      | ESP                         | B                      | 0.24                  | --         | 0.56                    | --        |

TABLE B-1. (continued)

| Industry sector <sup>a</sup> | Facility type <sup>b</sup> | Control status <sup>c</sup> | Coal type <sup>d</sup> | Emission factor       |           |                         |           |
|------------------------------|----------------------------|-----------------------------|------------------------|-----------------------|-----------|-------------------------|-----------|
|                              |                            |                             |                        | kg/10 <sup>15</sup> J |           | lb/10 <sup>12</sup> Btu |           |
|                              |                            |                             |                        | Mean                  | Range     | Mean                    | Range     |
| U                            | PC/WB                      | ESP                         | B                      | 0.27                  | --        | 0.63                    | --        |
| U                            | PC/WB                      | VS                          | B                      | 0.037                 | --        | 0.086                   | --        |
| U                            | PC/WB                      | ESP                         | B                      | 0.60                  | --        | 1.4                     | --        |
| U                            | PC/WB                      | ESP                         | B                      | 1.1                   | --        | 2.6                     | --        |
| U                            | CY                         | WS                          | B                      | 210                   | --        | 490                     | --        |
| U                            | CY                         | ESP                         | B                      | 1.3                   | --        | 3.0                     | --        |
| U                            | CY                         | ESP                         | B                      | 0.47                  | --        | 1.1                     | --        |
| U                            | CY                         | ESP                         | B                      | 0.15                  | --        | 0.35                    | --        |
| U                            | CY                         | ESP                         | B                      | 0.47                  | --        | 1.1                     | --        |
| U                            | CY                         | UN                          | B                      | 12                    | 9.5-15    | 28                      | 22-35     |
| U                            | CY                         | ESP                         | B                      | 0.34                  | 0.30-0.39 | 0.80                    | 0.70-0.90 |
| U                            | S                          | FF                          | B                      | 0.14                  | --        | 0.33                    | --        |
| U                            | S                          | MP                          | B                      | 1.8                   | --        | 4.2                     | --        |
| U                            | S                          | MC                          | B                      | 9.5                   | --        | 22                      | --        |
| U                            | CY                         | UN                          | SB                     | 1,900                 | --        | 4,400                   | --        |
| U                            | CY                         | WS                          | SB                     | 210                   | --        | 490                     | --        |
| U                            | PC                         | VS                          | SB                     | 1.7                   | --        | 4.0                     | --        |
| U                            | PC                         | ESP                         | SB                     | <0.17                 | --        | <0.40                   | --        |
| U                            | NA                         | ESP                         | SB                     | 0.17                  | --        | 0.39                    | --        |
| U                            | NA                         | ESP                         | SB                     | 0.73                  | --        | 1.7                     | --        |
| U                            | PC/DB                      | MC                          | L                      | 11                    | --        | 26                      | --        |
| U                            | PC/DB                      | MC                          | L                      | 2.2                   | --        | 5.1                     | --        |
| U                            | PC/DB                      | ESP                         | L                      | <1.5                  | --        | <3.5                    | --        |
| U                            | CY                         | ESP                         | L                      | 0.52                  | --        | 1.2                     | --        |
| U                            | CY                         | CY                          | L                      | 6.9                   | --        | 16                      | --        |
| U                            | CY                         | ESP/WS                      | L                      | 13                    | 0.77-25   | 31                      | 1.8-59    |

TABLE B-1. (continued)

| Industry sector <sup>a</sup> | Facility type <sup>b</sup> | Control status <sup>c</sup> | Coal type <sup>d</sup> | Emission factor       |         |                         |         |
|------------------------------|----------------------------|-----------------------------|------------------------|-----------------------|---------|-------------------------|---------|
|                              |                            |                             |                        | kg/10 <sup>15</sup> J |         | lb/10 <sup>12</sup> Btu |         |
|                              |                            |                             |                        | Mean                  | Range   | Mean                    | Range   |
| U                            | SS                         | MC                          | L                      | 2.3                   | --      | 5.3                     | --      |
| U                            | SS                         | ESP                         | L                      | 0.82                  | --      | 1.9                     | --      |
| I                            | PC/DB                      | ESP                         | B                      | 8.6                   | --      | 20                      | --      |
| I                            | PC/DB                      | ESP                         | B                      | 0.21                  | --      | 0.49                    | --      |
| I                            | PC/DB                      | MC                          | B                      | 200                   | --      | 460                     | --      |
| I                            | PC/DB                      | MC/WS                       | B                      | 0.42                  | --      | 0.98                    | --      |
| I                            | PC/DB                      | UN                          | B                      | 124                   | --      | 290                     | --      |
| I                            | PC/DB                      | ESP                         | B                      | 17                    | --      | 39                      | --      |
| I                            | PC/WB                      | MC                          | B                      | 0.65                  | --      | 1.5                     | --      |
| I                            | SS                         | MC/ESP                      | B                      | 0.0039                | --      | 0.0090                  | --      |
| I                            | SS                         | MC                          | B                      | 0.082                 | --      | 0.19                    | --      |
| I                            | SS                         | MC                          | B                      | 0.40                  | --      | 0.93                    | --      |
| I                            | SS                         | UN                          | B                      | 2.1                   | 1.8-2.4 | 4.8                     | 4.1-5.6 |
| I                            | SS                         | UN                          | B                      | 8.6                   | 6.9-9.4 | 20                      | 16-23   |
| I                            | SS                         | UN                          | B                      | 15                    | --      | 35                      | --      |
| I                            | SS                         | UN                          | B                      | 3.7                   | --      | 8.7                     | 7.4-10  |
| I                            | SS                         | UN                          | B                      | 9.5                   | --      | 22                      | 20-25   |
| I                            | SS                         | UN                          | B                      | 19                    | --      | 45                      | 25-65   |
| I                            | OS                         | UN                          | B                      | 16                    | --      | 37                      | --      |
| I                            | OS                         | UN                          | B                      | 5.2                   | --      | 12                      | --      |
| I                            | OS                         | UN                          | B                      | 77                    | 26-130  | 180                     | 60-300  |
| I                            | OS                         | UN                          | B                      | 43                    | --      | 100                     | --      |
| I                            | OS                         | MP                          | B                      | 24                    | 19-29   | 56                      | 44-67   |
| I                            | SS                         | UN                          | B                      | 5.6                   | --      | 13                      | --      |
| I                            | SS                         | ESP                         | B                      | 0.56                  | --      | 1.3                     | --      |
| I                            | SS                         | UN                          | B                      | 4.7                   | --      | 11                      | --      |

TABLE B-1. (continued)

| Industry sector <sup>a</sup> | Facility type <sup>b</sup> | Control status <sup>c</sup> | Coal type <sup>d</sup> | Emission factor       |         |                         |        |
|------------------------------|----------------------------|-----------------------------|------------------------|-----------------------|---------|-------------------------|--------|
|                              |                            |                             |                        | kg/10 <sup>15</sup> J |         | lb/10 <sup>12</sup> Btu |        |
|                              |                            |                             |                        | Mean                  | Range   | Mean                    | Range  |
| I                            | SS                         | ESP                         | B                      | 1.8                   | --      | 4.2                     | --     |
| I                            | SS                         | UN                          | SB                     | 6.0                   | 2.1-9.9 | 14                      | 4.9-23 |
| I                            | SS                         | UN                          | SB                     | 34                    | --      | 78                      | --     |
| I                            | SS                         | MP/ESP                      | SB                     | 2.5                   | --      | 5.7                     | --     |
| I                            | SS                         | UN                          | SB                     | 120                   | --      | 290                     | --     |
| I                            | SS                         | MP/ESP                      | SB                     | 6.0                   | --      | 14                      | --     |
| C                            | PC/DB                      | UN                          | B                      | 5.5                   | --      | 13                      | --     |
| C                            | PC/DB                      | MC/WS                       | B                      | 0.15                  | --      | 0.35                    | --     |
| C                            | SS                         | MP                          | B                      | 2.4                   | --      | 5.6                     | --     |
| C                            | OS                         | MP                          | B                      | 0.52                  | --      | 1.2                     | --     |
| C                            | S                          | UN                          | A                      | 0.99                  | --      | 2.3                     | --     |
| C                            | S                          | UN                          | A                      | 1.5                   | --      | 3.5                     | --     |
| C                            | S                          | UN                          | A                      | 0.60                  | --      | 1.4                     | --     |
| R                            | NA                         | UN                          | B                      | 67                    | --      | 160                     | --     |
| R                            | NA                         | UN                          | B                      | 13                    | --      | 31                      | --     |
| R                            | S                          | UN                          | B                      | 3.8                   | --      | 8.9                     | --     |
| R                            | S                          | UN                          | B                      | <19                   | --      | <44                     | --     |

<sup>a</sup>U = utility, I = industrial, C = commercial, R = residential.

<sup>b</sup>PC = pulverized coal, DB = dry bottom, WB = wet bottom, CY = cyclone, NA = not available, SS = spreader stoker, OS = overfeed stoker, S = stoker.

<sup>c</sup>ESP= electrostatic precipitator, WS = wet scrubber, MP = mechanical precipitation device, UN = uncontrolled, VS = venturi scrubber, FF = fabric filter, MC = multiclone, CY = cyclone.

<sup>d</sup>B = bituminous, SB = subbituminous, L = lignite, A = anthracite.

TABLE B-2. SUMMARY OF MUNICIPAL WASTE COMBUSTOR EMISSION DATA

| Facility name             | Combustor type <sup>a</sup> | Control technology <sup>b</sup> | Concentration<br>µg/dscm @ 7% O <sub>2</sub> <sup>c</sup> |
|---------------------------|-----------------------------|---------------------------------|---|
| Commerce                  | MB/WW                       | UN                              | 960   |
| Commerce                  | MB/WW                       | UN                              | 1,600   |
| Commerce average          | MB/WW                       | UN                              | 1,280   |
| Quebec City - Pilot       | MB/WW                       | UN                              | 1,000   |
| Quebec City - Pilot       | MB/WW                       | UN                              | 1,500   |
| Quebec City - Pilot       | MB/WW                       | UN                              | 1,200   |
| Quebec City - Pilot       | MB/WW                       | UN                              | 1,300   |
| Quebec City - Pilot       | MB/WW                       | UN                              | 1,100   |
| Quebec City - Pilot       | MB/WW                       | UN                              | 1,200   |
| Quebec City average       | MB/WW                       | UN                              | 1,220   |
| Vancouver                 | MB/WW                       | UN                              | 1,200   |
| Babylon                   | MB/WW                       | SD/FF                           | 1.00  |
| Babylon                   | MB/WW                       | SD/FF                           | 5.00  |
| Babylon                   | MB/WW                       | SD/FF                           | bd  |
| Babylon average           | MB/WW                       | SD/FF                           | 2.00  |
| Bridgeport                | MB/WW                       | SD/FF                           | bd  |
| Bridgeport                | MB/WW                       | SD/FF                           | 4.00  |
| Bridgeport                | MB/WW                       | SD/FF                           | bd  |
| Bridgeport average        | MB/WW                       | SD/FF                           | 1.33  |
| Bristol                   | MB/WW                       | SD/FF                           | 2.00  |
| Bristol                   | MB/WW                       | SD/FF                           | 1.00  |
| Bristol                   | MB/WW                       | SD/FF                           | 2.00  |
| Bristol average           | MB/WW                       | SD/FF                           | 1.67  |
| Commerce                  | MB/WW                       | SD/FF                           | 0.400   |
| Commerce                  | MB/WW                       | SD/FF                           | 2.00  |
| Commerce average          | MB/WW                       | SD/FF                           | 1.20  |
| Fairfax                   | MB/WW                       | SD/FF                           | 9.00  |
| Fairfax                   | MB/WW                       | SD/FF                           | 6.00  |
| Fairfax                   | MB/WW                       | SD/FF                           | 6.00  |
| Fairfax                   | MB/WW                       | SD/FF                           | 5.00  |
| Fairfax average           | MB/WW                       | SD/FF                           | 6.50  |
| Gloucester                | MB/WW                       | SD/FF                           | bd  |
| Gloucester                | MB/WW                       | SD/FF                           | bd  |
| Gloucester                | MB/WW                       | SD/FF                           | bd  |
| Glouster average          | MB/WW                       | SD/FF                           | 0.00  |
| Hempstead                 | MB/WW                       | SD/FF                           | bd  |
| Hempstead                 | MB/WW                       | SD/FF                           | bd  |
| Hempstead                 | MB/WW                       | SD/FF                           | bd  |
| Hempstead average         | MB/WW                       | SD/FF                           | 0.00  |
| Kent                      | MB/WW                       | SD/FF                           | 4.00  |
| Kent                      | MB/WW                       | SD/FF                           | 4.00  |
| Kent average              | MB/WW                       | SD/FF                           | 4.00  |
| Long Beach                | MB/WW                       | SD/FF                           | 18.0  |
| Marion County             | MB/WW                       | SD/FF                           | 3.00  |
| Stanislaus County         | MB/WW                       | SD/FF                           | 2.00  |
| Stanislaus County         | MB/WW                       | SD/FF                           | 2.00  |
| Stanislaus County         | MB/WW                       | SD/FF                           | 2.00  |
| Stanislaus County average | MB/WW                       | SD/FF                           | 2.00  |

TABLE B-2. (continued)

| Facility name           | Combustor type <sup>a</sup> | Control technology <sup>b</sup> | Concentration<br>μg/dscm @ 7% O <sub>2</sub> <sup>c</sup> |
|-------------------------|-----------------------------|---------------------------------|---|
| Haverhill               | MB/WW                       | SD/ESP                          | 38.0  |
| Haverhill               | MB/WW                       | SD/ESP                          | 18.0  |
| Haverhill               | MB/WW                       | SD/ESP                          | 10.0  |
| Haverhill average       | MB/WW                       | SD/ESP                          | 22.0  |
| Millbury                | MB/WW                       | SD/ESP                          | 13.0  |
| Millbury                | MB/WW                       | SD/ESP                          | 22.0  |
| Millbury                | MB/WW                       | SD/ESP                          | 32.0  |
| Millbury                | MB/WW                       | SD/ESP                          | 6.00  |
| Millbury                | MB/WW                       | SD/ESP                          | 18.0  |
| Millbury                | MB/WW                       | SD/ESP                          | 7.00  |
| Millbury                | MB/WW                       | SD/ESP                          | 11.0  |
| Millbury average        | MB/WW                       | SD/ESP                          | 15.6  |
| Portland                | MB/WW                       | SD/ESP                          | 4.00  |
| Portland                | MB/WW                       | SD/ESP                          | 4.00  |
| Portland average        | MB/WW                       | SD/ESP                          | 4.00  |
| Pinellas County         | MB/WW                       | ESP                             | 8.00  |
| Tulsa                   | MB/WW                       | ESP                             | 390   |
| Tulsa                   | MB/WW                       | ESP                             | 140   |
| Tulsa average           | MB/WW                       | ESP                             | 265   |
| Vancouver               | MB/WW                       | DSI/FF                          | 4.00  |
| Dutchess County         | MB/RC                       | DSI/FF                          | 3.00  |
| Dutchess County         | MB/RC                       | DSI/FF                          | 3.00  |
| Dutchess County average | MB/RC                       | DSI/FF                          | 3.00  |
| Dayton                  | MB/REF                      | UN                              | 1,200   |
| Dayton                  | MB/REF                      | UN                              | 1,100   |
| Dayton                  | MB/REF                      | UN                              | 1,950   |
| Dayton                  | MB/REF                      | UN                              | 1,300   |
| Dayton                  | MB/REF                      | UN                              | 1,500   |
| Dayton average          | MB/REF                      | UN                              | 1,410   |
| Dayton                  | MB/REF                      | ESP                             | 30.0  |
| Dayton                  | MB/REF                      | ESP                             | 19.0  |
| Dayton average          | MB/REF                      | ESP                             | 24.5  |
| Dayton                  | MB/REF                      | DSI/ESP                         | 11.0  |
| Biddeford               | RDF                         | UN                              | 1,100   |
| Mid-Connecticut         | RDF                         | UN                              | 500   |
| Mid-Connecticut         | RDF                         | UN                              | 567   |
| Mid-Connecticut         | RDF                         | UN                              | 1,100   |
| Mid-Connecticut         | RDF                         | UN                              | 600   |
| Mid-Connecticut         | RDF                         | UN                              | 617   |
| Mid-Connecticut average | RDF                         | UN                              | 677   |

TABLE B-2. (continued)

| Facility name           | Combustor type <sup>a</sup> | Control technology <sup>b</sup> | Concentration<br>μg/dscm @ 7% O <sub>2</sub> <sup>c</sup> |
|-------------------------|-----------------------------|---------------------------------|---|
| Biddeford               | RDF                         | SD/FF                           | bd  |
| Mid-Connecticut         | RDF                         | SD/FF                           | bd  |
| Mid-Connecticut         | RDF                         | SD/FF                           | bd  |
| Mid-Connecticut         | RDF                         | SD/FF                           | bd  |
| Mid-Connecticut         | RDF                         | SD/FF                           | bd  |
| Mid-Connecticut average | RDF                         | SD/FF                           | 0.00  |
| Semass                  | RDF                         | SD/ESP                          | 10.0  |
| Semass                  | RDF                         | SD/ESP                          | 7.00  |
| Semass average          | RDF                         | SD/ESP                          | 8.50  |
| Detroit                 | RDF                         | ESP                             | bd  |
| Detroit                 | RDF                         | ESP                             | bd  |
| Detroit                 | RDF                         | ESP                             | bd  |
| Detroit average         | RDF                         | ESP                             | 0.00  |
| Albany                  | RDF                         | ESP                             | 33.7  |
| St. Croix               | MOD/EA                      | DSI/FF                          | 2.00  |
| Dyersburg               | MOD/SA                      | UN                              | 238   |
| N. Little Rock          | MOD/SA                      | UN                              | 360   |
| Barron County           | MOD/SA                      | ESP                             | 220   |
| Oneida County           | MOD/SA                      | ESP                             | 920   |

<sup>a</sup>MB = mass burn, WW = water wall, RC = rotary water wall, = REF = refractory wall, RDF = refuse-derived fuel-fired, MOD = modular, SA = starved air, EA = excess air.

<sup>b</sup>UN = uncontrolled, SD = spray dryer, FF = fabric filter, ESP = electrostatic precipitator, DSI = dry sorbent injection.

<sup>c</sup>bd = below detection limit.



TABLE B-3. SUMMARY OF SEWAGE SLUDGE INCINERATOR EMISSION DATA

| Incinerator type <sup>a</sup> | Control status <sup>b</sup> | Emission factor |                                    |
|-------------------------------|-----------------------------|-----------------|------------------------------------|
|                               |                             | g/Mg dry sludge | 10 <sup>-3</sup> lb/ton dry sludge |
| FB                            | IS                          | 0.15            | 0.30                               |
| FB                            | VS/IS                       | 0.55            | 1.1                                |
| FB                            | VS/IS                       | 1.4             | 2.9                                |
| FB                            | VS/IS                       | 0.27            | 0.55                               |
| FB                            | VS/IS                       | 0.0035          | 0.0070                             |
| MH                            | UN                          | 49              | 98                                 |
| MH                            | UN                          | 0.0010          | 0.0020                             |
| MH                            | UN                          | 5.3             | 11                                 |
| MH                            | UN                          | 51              | 100                                |
| MH                            | VS                          | 0.17            | 0.35                               |
| MH                            | VS                          | 0.65            | 1.8                                |
| MH                            | IS                          | 1.5             | 3.0                                |
| MH                            | IS                          | 1.2             | 2.4                                |
| MH                            | VS/IS                       | 1.9             | 3.8                                |
| MH                            | VS/IS                       | 7.8             | 16                                 |
| MH                            | VS/IS                       | 2.7             | 5.4                                |
| MH                            | VS/IS                       | 0.32            | 0.64                               |
| MH                            | VS/IS/AB                    | 2.1             | 4.2                                |
| MH                            | CY                          | 32              | 65                                 |
| MH                            | CY                          | 0.86            | 1.7                                |
| MH                            | CY                          | 4.4             | 8.8                                |
| MH                            | CY/VS                       | 25              | 50                                 |
| MH                            | CY/VS/IS                    | 8.1             | 16                                 |
| MH                            | ESP                         | 0.17            | 0.35                               |
| MH                            | FF                          | 0.014           | 0.027                              |

<sup>a</sup>MH = multiple hearth, FB = fluidized-bed.

<sup>b</sup>IS = impingement scrubber, VS = venturi scrubber, UN = uncontrolled, AB = afterburner, CY = cyclone, ESP = electrostatic precipitator, FF = fabric filter.

TABLE B-4. SUMMARY OF MEDICAL WASTE INCINERATOR EMISSION DATA

| Facility                   | Waste type <sup>a</sup> | Control status <sup>b</sup> | No. of runs | Emission factor |                       |                                  |                       |
|----------------------------|-------------------------|-----------------------------|-------------|-----------------|-----------------------|----------------------------------|-----------------------|
|                            |                         |                             |             | g/Mg of waste   |                       | 10 <sup>-3</sup> lb/ton of waste |                       |
|                            |                         |                             |             | Average         | Range                 | Average                          | Range                 |
| Fox Chase                  | M                       | VS/PB                       | 3           | 9.95            | --                    | 19.9                             | --                    |
| Southland                  | M                       | DSI/ESP                     | 3           | 0.297           | 0.264-0.360           | 0.593                            | 0.528-0.719           |
| Royal Jubilee <sup>c</sup> | M                       | UN                          | 2           | 1.31            | 0.951-1.66            | 2.61                             | 1.90-3.32             |
| Mega                       | NA                      | VS/PB                       | 3           | 2.93            | 1.16-6.27             | 5.86                             | 2.33-12.5             |
| St. Bernadines             | M                       | UN                          | 3           | 0.619           | 0.552-0.703           | 1.24                             | 1.10-1.41             |
| Sutter (1988)              | M                       | UN                          | 6           | 1.05            | 0.420-1.86            | 2.11                             | 0.840-3.71            |
| Sutter (1987)              | M                       | UN                          | 3           | 1.12            | 0.118-2.44            | 2.25                             | 0.237-4.88            |
| Stanford                   | M                       | UN                          | 3           | 1.01            | 0.475-1.47            | 2.02                             | 0.949-2.93            |
|                            | M                       | VS                          | 3           | 0.751           | 0.558-0.926           | 1.50                             | 1.12-1.85             |
| St. Agnes                  | M                       | UN                          | 3           | 1.59            | 1.24-2.04             | 3.19                             | 2.48-4.09             |
| Cedars Sinai               | M                       | UN                          | 3           | 2.22            | 1.45-3.40             | 4.44                             | 2.90-6.80             |
|                            |                         | FF                          | 3           | <0.00258        | <0.00245-<br><0.00265 | <0.00516                         | <0.00490-<br><0.00531 |
| Nazareth                   | M                       | VS/PB                       | 2           | 1.48            | 0.714-2.24            | 2.96                             | 1.43-4.49             |
| Kaiser                     | M                       | WS                          | 3           | 2.57            | 1.06-5.31             | 5.13                             | 2.12-10.6             |
| USC                        | M                       | UN                          | 3           | 2.60            | 0.921-3.69            | 5.20                             | 1.84-7.38             |
| Borgess                    | G500                    | UN                          | 14          | 4.39            | 1.27-21.9             | 8.77                             | 2.54-43.9             |
|                            |                         | DI/FF                       | 9           | 0.0101          | 0.00615-0.0147        | 0.0203                           | 0.0123-<br>0.0294     |
|                            |                         | DI/FF+C <sup>d</sup>        | 2           | 0.0152          | 0.0150-0.0154         | 0.0303                           | 0.0299-<br>0.0307     |
|                            |                         | DI/FF+C <sup>e</sup>        | 3           | 0.0723          | 0.00642-0.195         | 0.145                            | 0.0128-<br>0.391      |
|                            | RB                      | UN                          | 10          | 1.63            | 0.722-2.52            | 3.26                             | 1.44-5.03             |
|                            |                         | DI/FF                       | 9           | 0.0131          | 0.00959-0.0156        | 0.0261                           | 0.0192-<br>0.0313     |
|                            | G100                    | UN                          | 2           | 1.56            | 0.792-2.33            | 3.12                             | 1.58-4.66             |
| University of Michigan     | M                       | UN                          | 3           | 4.32            | 3.26-5.86             | 8.65                             | 6.53-11.7             |
|                            |                         | VS/PB                       | 3           | 2.69            | 2.11-3.81             | 5.38                             | 4.22-7.63             |
| Lenoir                     | M                       | UN                          | 9           | 3.04            | 1.05-6.78             | 6.07                             | 2.10-13.6             |
| Cape Fear                  | M                       | UN                          | 9           | 5.68            | 3.90-6.74             | 11.4                             | 7.81-13.5             |

TABLE B-4. (continued)

| Facility             | Waste type <sup>a</sup> | Control status <sup>b</sup> | No. of runs | Emission factor |                |                                  |               |
|----------------------|-------------------------|-----------------------------|-------------|-----------------|----------------|----------------------------------|---------------|
|                      |                         |                             |             | g/Mg of waste   |                | 10 <sup>-3</sup> lb/ton of waste |               |
|                      |                         |                             |             | Average         | Range          | Average                          | Range         |
| AMI Central Carolina | M                       | UN                          | 3           | 0.461           | 0.403-0.575    | 0.923                            | <0.807-1.15   |
|                      | P                       | UN                          | 6           | 0.902           | <0.000-4.67    | 1.80                             | <0.000-9.34   |
| Morristown           | M                       | UN                          | 6           | 6.86            | 4.72-8.25      | 13.7                             | 9.43-16.5     |
|                      |                         | SD/FF                       | 3           | 0.0213          | 0.0104-0.0293  | 0.0427                           | 0.0208-0.0587 |
|                      |                         | SD/FF+C                     | 3           | 0.0121          | 0.00955-0.0145 | 0.0242                           | 0.0191-0.0290 |

<sup>a</sup>M = mixed medical waste, NA = not available, G500 = mixed waste from 500-bed hospital, RB = red bag waste, G100 = mixed waste from 100-bed hospital, P = pathological waste.

<sup>b</sup>VS = venturi scrubber, PB = packed bed, DSI = duct sorbent injection, ESP = electrostatic precipitator, UN = uncontrolled, FF = fabric filter, WS = wet scrubber, DI = dry injection, C = carbon addition, SD = spray dryer.

<sup>c</sup>Sampling method suspect, results biased low.

<sup>d</sup>Carbon injection at 1 lb/hr rate.

<sup>e</sup>Carbon injection at 2.5 lb/hr rate.