

TECHNICAL STANDARD OPERATING PROCEDURE

Date: April 1, 2004 (Rev. # 0)

SOP No. SRC-DUST-01

Title: HIGH VOLUME INDOOR DUST SAMPLING AT RESIDENCES FOR DETERMINATION OF RISK-BASED EXPOSURE TO METALS

APPROVALS:

Author Syracuse Research Corporation

SYNOPSIS: A standardized high-volume vacuum method for collection of indoor dust at residences is described. This method is suitable for measurement of either contaminant concentration (mg/kg) or contaminant loading (mg/m²) in indoor dust.

REVIEWS:

TEAM MEMBER

SIGNATURE

DATE

USEPA Region 8

Syracuse Research Corp.

TECHNICAL STANDARD OPERATING PROCEDURE
INTERIOR SURFACE DUST SAMPLING AT RESIDENCES

1.0 PURPOSE

The purpose of this standard operating procedure (SOP) is to provide a standard approach for collection of interior surface dust samples within a residence. The SOP includes a description of the equipment and methods to be used. This protocol will be implemented by employees of USEPA Region 8 or contractors and subcontractors supporting Region 8 projects and tasks.

2.0 RESPONSIBILITIES

The Field Project Leader (FPL) is responsible for ensuring that all dust samples collected are obtained in accord with the procedures specified in this SOP. The FPL may be an USEPA employee or an USEPA contractor. The FPL is responsible for training all Field Personnel in the methods and techniques specified in this SOP and for checking that all work performed satisfies the specific tasks outlined by this SOP and the Project Plan. It is the responsibility of the FPL to identify any deviations from the SOP that may be required and to obtain approval for these deviations from the USEPA Region 8 Remedial Project Manager, Regional Toxicologist, or Field Quality Assurance Coordinator prior to initiation of any sampling activities that are not in accord with this SOP.

3.0 DUST COLLECTION PROTOCOL

3.1 Overview

This protocol is for collection of dust samples from interior surfaces using a high-volume vacuum method. The sampling method is based on the method of Roberts et al. (1989, 1991, 1994) and Stamper et al. (1990), and is presented in ASTM's *Standard Practice for Collection of Dust from Carpeted Floors for Chemical Analysis* (ASTM 1993). The protocol is suitable for the collection of interior dust samples from either hard or smooth and highly textured surfaces, such as brickwork and rough concrete, and soft, fibrous surfaces, such as upholstery and carpeting.

In general, one dust sample will be collected at each residence. This sample will be a composite of dust collected from multiple different sub-locations within the residence. At each sub-sampling location, dust is withdrawn from the surface area by means of a flowing air stream passing through a sampling nozzle at a specific velocity and flow rate. Dust is separated from the air mechanically by a cyclone and is collected in a catch bottle attached to the bottom of the cyclone. The cyclone collects particles approximately 5- μ m mean aerodynamic diameter and larger. The collected sample is substantially unmodified by the sampling procedure.

TECHNICAL STANDARD OPERATING PROCEDURE
INTERIOR SURFACE DUST SAMPLING AT RESIDENCES

3.2 SAMPLING EQUIPMENT

3.2.1 Sampling Apparatus

The sampling apparatus may be acquired commercially [CS₃ model HVS3] (see Figure 1) or constructed. The dimensions of the sampling apparatus (nozzle size, cyclone diameter, cyclone inlet diameter, etc.) are interdependent. The flow rate must produce a sufficient velocity both at the sampling surface and in the cyclone. The cyclone must have a cut diameter of 5 µm at the same velocity that will provide a horizontal velocity of 40 cm/s at 10 mm from the nozzle in the carpet material. The fundamental principles of this device have been discussed in Roberts et al. (ASTM 1994).

- **Nozzle** – The edges and corners of the sampling nozzle shall be rounded to prevent catching any carpeted material. The nozzle must be constructed to allow for sufficient suction to separate loose particles from the carpet and carry them to the cyclone. It must have an adjustment mechanism to establish the nozzle lip parallel to the surface and to achieve the proper suction velocity and pressure drop across the nozzle. A nozzle 12.4 cm long and 1 cm wide, with a 13-mm flange and tapered to the nozzle tubing at no more than 30°, will yield the appropriate velocities when operated as specified.
- **Gaskets** – Gaskets in joints should be of a material appropriate to avoid sample contamination.
- **Cyclone** – The cyclone shall must be constructed such that air flow allows for separation of particles 5-µm mean aerodynamic diameter and larger. The cyclone must be made of aluminum or stainless steel.
- **Catch Bottle** – The catch bottle must be either a 500-mL amber glass jar (Fisher Scientific Cat. No. 03-320-4C) or 500-mL fluorinated ethylene propylene (FEP) bottle (Fisher Scientific Cat. No. 03-312-22) to avoid contamination and allow the operator to see the sample.
- **Flow Control System** – The flow control system shall allow for substantial volume adjustment. The suction source must be capable of drawing 12 L/s through the system with no restrictions other than the nozzle, cyclone, and flow control system connected. A commercial vacuum cleaner can be used for this purpose.
- **Flow Measuring and Suction Gages** – The use of Magnehelic gages for measurement of the pressure drop at the nozzle and for control of the flow rate for the entire system is considered adequate and applicable for this sampling practice.

3.2.2 Other Equipment

- Stop Watch
- Disposable Gloves
- Trash bag for disposing of wipes, gloves

TECHNICAL STANDARD OPERATING PROCEDURE

INTERIOR SURFACE DUST SAMPLING AT RESIDENCES

- 50 cm long x 3 cm diameter brush for decontamination of the apparatus
- 500-mL squeeze bottle with analyte-free deionized water
- 500-mL squeeze bottle with soapy (e.g., Liquinox) analyte-free water
- Wipes
- Masking tape and marking pen
- Sieve – 150 μm mesh; #100 sieve must be either stainless steel or plastic
- Analytical balance – accurate to 0.1 g; weighing range of 0.1 mg to 1000g
- Template (2 ft x 2 ft [2 ft²])

3.2.3 Reagents and Materials

Any chemicals used for decontamination must be reagent grade or better.

3.3 Preparation and Calibration

Preparation - Clean the wheels and nozzle lip with a clean laboratory tissue immediately before sampling. The sampling train shall be inspected to ensure that it has been cleaned and assembled properly. The sampling train shall be leak-checked prior to sampling. This can be accomplished by placing a mailing envelope or a piece of cardboard beneath the nozzle and switching on the suction source. The flow Magnehelic gage should read 5 Pa (0.02 in. H₂O) or less. If any leakage is detected, the system shall be inspected for the cause and corrected before use.

Calibration-The sampling strategy described in this practice does not have any calibrated flow devices other than the cyclone and the Magnehelic gages. The cyclone used for the separation of the particles must be designed to give proper separation at varying flow rates throughout the sampling range of the system. The pressure gages and any other devices (that is, temperature gage) used for testing purposes should be calibrated against a primary standard. Adjust the flow rate and nozzle pressure drop to values that approximate those given in Section 3.6.

- Pressure Gages – Pressure gages shall be calibrated against an inclined manometer or other primary standard at the beginning of each day. One means of checking a Magnehelic gage is to set a flow rate through the sampling system with a manometer and then switch to the Magnehelic gage. If the difference in the readings is more than 3%, the gage is leaking or is in need of repair or calibration. This should be done at two different flow rates when checking the gage.

3.4 Sample Label and Field Data Sheet

Before beginning the dust collection protocol within a residence, first attach a pre-made site-specific sample identification label to a clean dust collection bottle and attach the

TECHNICAL STANDARD OPERATING PROCEDURE

INTERIOR SURFACE DUST SAMPLING AT RESIDENCES

bottle to the sampling device. Then attach the corresponding pre-made sample identification number to the field data sheet for that sample. This field data sheet is presented in Figure 2 and is provided electronically as Attachment 1. On the data sheet, fill in the appropriate information on the sampling team, date, residence address, etc. As sampling progresses, record the location of each template collected on the field data sheet.

3.5 Sampling Locations within the Residence

A single composite of dust will be collected on the floor at each residence (e.g., dust will not be collected from window sills, furniture, etc.). This composite will be composed of dust collected from a number of sub-sampling locations, identified as below. All sub-samples will be collected in rooms or other living areas (“living spaces”) where the residents are most likely to be exposed. This includes bedrooms, family and/or television rooms, kitchens, hallways and entryways.

In most cases, two templates will be collected per living space. Thus, the total number of sub-samples collected within a residence will be dependent upon the number of living spaces available. In the case where a residence has more than 10 living spaces, only 1 template per living space will be collected. This approach is recommended so that 20-30 sub-samples are not collected for a large residence.

Sub-sample locations within a living space (living space sample points) should focus on areas with the greatest potential for exposure. This is typically along the center axis of the living space. Corners of rooms, areas beneath furniture, etc., are not likely to be high exposure areas (even if especially dusty) and will not be sampled.

3.6 Sampling Procedure

At each sub-location within the house to be sampled (see below), place the template on the sampling surface. If needed, use masking tape to temporarily hold the template to the surface so the template does not move during sampling. Turn on the vacuum and place the nozzle in one corner of the sampling area, then adjust the flow rate and pressure drop according to the type of surface. For hard surfaces or level loop carpet, the flow rate should be adjusted to at least 7.8 L/s (18 cfm), and the nozzle drop should be at least 2.2 kPa (9 in. H₂O). For plush or shag carpet, the flow rate must be at least 9.5 L/s (20 cfm), and the nozzle pressure drop must be at least 2.5 kPa (10 in. H₂O). The two factors that affect the efficiency of the sampling system are the flow rate and pressure drop at the nozzle. The pressure drop at the nozzle is a function of the flow rate and distance between the surface and the nozzle flange.

Begin sampling by moving the nozzle along one edge of the sampling area template. Move the nozzle at approximately 0.5 m/s back and forth four times along the edge.

TECHNICAL STANDARD OPERATING PROCEDURE
INTERIOR SURFACE DUST SAMPLING AT RESIDENCES

Then move the nozzle inward at a distance equal to the sampling width of the nozzle and make four passes parallel to the edge of the template. Repeat this strip-by-strip collection pattern until the entire template area has been covered.

Switch off the vacuum and move to the next sampling sub-location within the residence. Repeat the process at each sub-location. When all sub-locations within the residence have been sampled, the catch bottle can be removed, labeled, and capped for storage and analysis in accord with the site-specific sampling and analysis plan.

3.7 Decontamination – Sampler Cleaning

After all sub-samples have been collected at a residence, the sampling equipment must be thoroughly decontaminated before beginning sampling at the next residence. With the sample collection bottle removed and safely stored, open the flow control valve to maximum flow, tip the sampler back so that the nozzle is approximately 5 cm (2 in.) off the floor, and switch the vacuum on. Place a hand covered by a rubber glove on the bottom of the cyclone and alternate closing and opening the cyclone for 10 seconds to free any loose material adhering to the walls of the cyclone and tubing. It is not necessary to catch this small amount of dust, as it is usually much less than 1% of the collected sample.

Remove the sampler to a well-ventilated cleaning area free of dust. Remove the cyclone and elbow at the top of the nozzle tubing from the sampler. Use a 50-cm long by 3-cm diameter (20 by 1.25-in.) brush to clean the nozzle, and clean all related items up to and including the cyclone and catch bottle. Cleaning should begin by first rinsing with the soapy water solution and then triple rinsing with deionized water that has been certified lead and arsenic free. Allow all equipment to air dry. The equipment must be completely dry before sampling again. The dry brushing and wet cleaning is performed to prevent contamination from passing from one sample to another. An equipment blank will be collected after every 20 decontaminations. Equipment blank sample collection is described in the QC section (Section 6.2).

3.8 Prevention of Cross-Contamination

The following work practices should be followed to prevent cross-contamination of samples:

- Avoid disturbing and tracking dust from one location to another by identifying and clearly marking all sampling locations upon arrival at the sampling site, avoiding walking through or over any of the marked sampling location areas, and instructing field team members to pull on new disposable shoe covers upon each entry into the building (this is especially significant if field teams have been walking through known exterior contamination sources).

TECHNICAL STANDARD OPERATING PROCEDURE
INTERIOR SURFACE DUST SAMPLING AT RESIDENCES

- Use a new pair of powderless gloves at each sampling location.
- Inspect all sampling equipment for cleanliness prior to collection of each sample.
- Do not open sample collection containers until needed to collect each sample.
- Immediately remove and dispose of gloves when sampling is complete.

5.0 SAMPLE STORAGE AND ANALYSIS

5.1 Sample Storage

After collection of the sample in the catch bottle, the bottle should be tightly capped, the security of the sample identification number checked, and the bottle placed in an appropriate storage container. Storage at ambient temperature for up to 180 days is appropriate for samples that will be analyzed only for metals.

5.2 Sample Preparation

Before analysis, each dust sample will be sieved to remove large non-dust material (hair, fibers, objects, etc.). Sieve the samples thorough a #100 mesh screen to isolate particles that are 150 μm or smaller. After sieving, weigh the sieved material to an accuracy of ± 0.1 g. This weight will be reported by the laboratory so that loading data may be determined. For field blanks, little or no measurable dust mass is expected to be obtained. To identify any potential systematic contamination that may occur during sample collection, equipment blanks will be collected instead, as described in Section 6.2. After decontamination, deionized water will be collected from the collection bottle, and submitted to the laboratory for analysis. Equipment blank samples should be prepared and analyzed as standard aqueous samples.

5.3 Sample Analysis

The analytes of interest for indoor dust are generally arsenic and lead. Sieved samples will be digested using nitric acid (SW-846 method 3050 or 3051) and analyzed using standard USEPA protocols via either graphite furnace atomic absorption (GFAA), Inductively Coupled Plasma/Mass Spectrometry (ICP/MS), or ICP-trace instrumentation, as needed to achieve the detection limits specified in the project-specific SAP. In general, detection limits of about 1 ppm are desirable for arsenic and about 5-10 ppm are desirable for lead.

TECHNICAL STANDARD OPERATING PROCEDURE
INTERIOR SURFACE DUST SAMPLING AT RESIDENCES

6.0 FIELD QUALITY ASSURANCE/QUALITY CONTROL

Adherence to quality assurance/quality control (QA/QC) procedures is an important part of field sample collection. Field QA/QC procedures include documentation requirements, and field QC samples.

6.1 Documentation Requirements

All field documentation requirements are included in the Indoor Dust Data Sheet (see Figure 2). Each sampling team must ensure that all required items are recorded on this field data sheet, that the sample number is firmly affixed, and that any deviations from the SOP are noted on the sheet.

6.2 Field QC Samples

Equipment blanks. Equipment blank samples are used to identify any potential systematic contamination due to improper decontamination during field collection activities. Equipment blanks should be collected after performing the appropriate equipment decontamination procedures (Section 3.7). Equipment blank samples will be collected at a frequency of 5% (1 equipment blank per 20 decontaminations). These samples are collected by drawing 100-120 mL of analyte-free water through the decontaminated high-volume vacuum apparatus and collecting the rinsate into a clean catch bottle.

Blind Standard (Reference Material) Samples. Blind standard will be submitted to the laboratory to determine the accuracy of metals analysis using this sample collection method. These QC samples will be submitted blindly to the laboratory at the frequency specified in the project-specific sampling (usually about 1 blind standard per 20 field samples).

TECHNICAL STANDARD OPERATING PROCEDURE
INTERIOR SURFACE DUST SAMPLING AT RESIDENCES

7.0 REFERENCES

American Society for Testing and Materials (ASTM). 1994. Standard Practice for Collection of Dust from Carpeted Floors for Chemical Analysis. ASTM Designation: D5438-93. September.

Bornschein. 1989. Midvale Community Lead Study, Appendix B: Quality Assurance Plan.

USEPA. 1995a. Residential Sampling for Lead: Protocols for Dust and Soil Sampling. Final Report. U.S. Environmental Protection Agency, Office of Pollution Prevention and Toxics. EPA 747-R-95-001.

USEPA. 1995b. Sampling House Dust for Lead. Basic Concepts and Literature Review. U.S. Environmental Protection Agency, Office of Pollution Prevention and Toxic Substances. EPA 747-R-95-007.

USEPA. 1996. Sampling Manual for IEUBK Model. Prepared by Roy F. Weston. Document control number 4800-045-0019.

Roberts, JW, et. al. 1991. *A Small High Volume Surface Sampler HVS3 for Pesticides, and Other Toxic Substances in House Dust*, Paper Number 91-150.2, 84th Annual Meeting, Air & Waste Management Association, Vancouver, British Columbia, June 16-21, 1991.

Roberts, JW and MG Ruby. 1989. *Development of a High Volume Surface Sampler for Pesticides*, U.S. Environmental Protection Agency Report No. EPA 600/4-88/036, Research Triangle Park, N.C. January 1989.

Stamper, VR, et. al. 1990. *Development of a High Volume Small Surface Sampler for Pesticides and Toxics in House Dust*, Research Triangle Park, N.C. June 1990. Included in supporting data, which are on file at ASTM Headquarters Request RR:D22-1010.

TECHNICAL STANDARD OPERATING PROCEDURE
INTERIOR SURFACE DUST SAMPLING AT RESIDENCES

Figure 1. High Volume Dust Collection Device

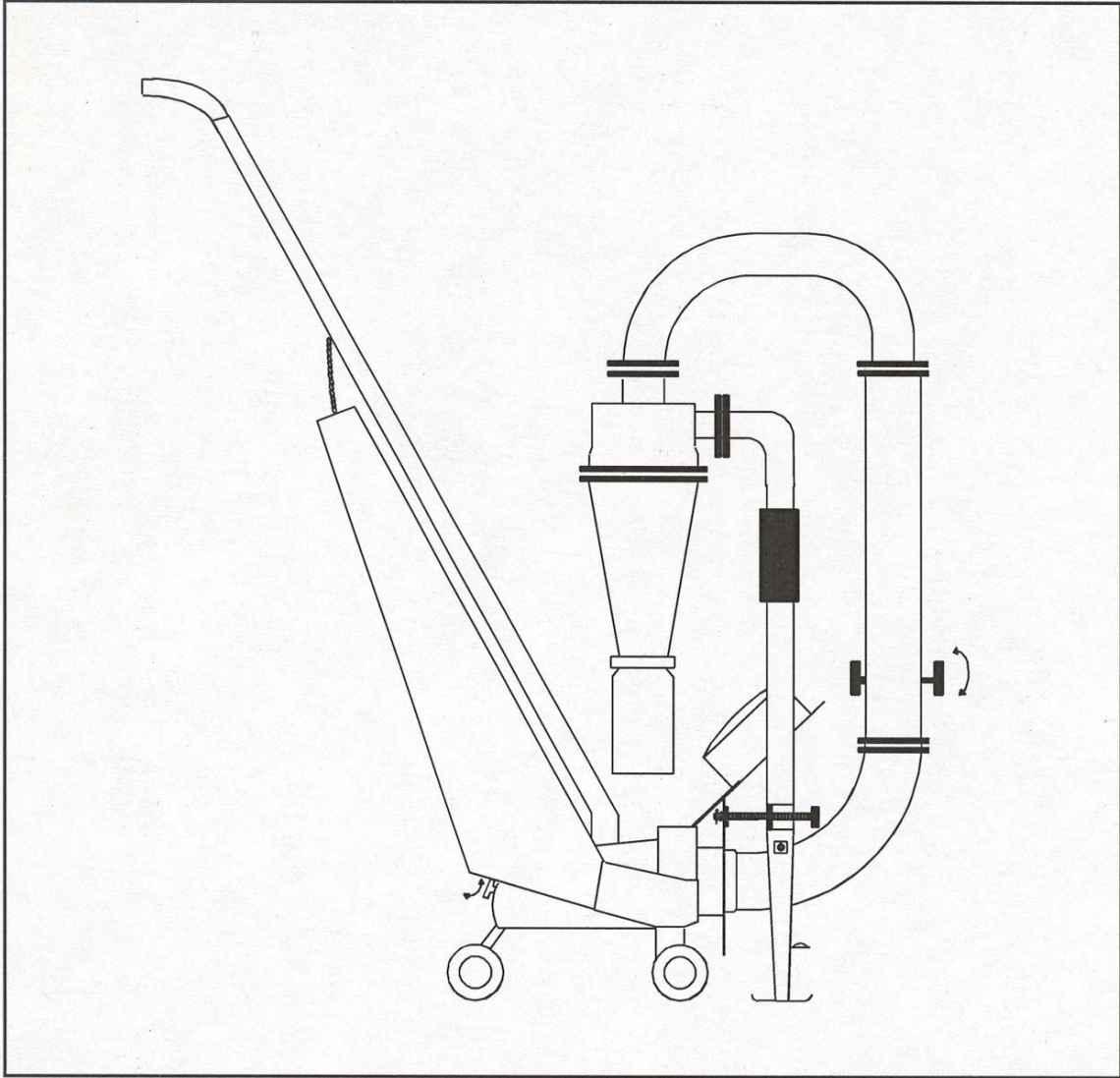

**TECHNICAL STANDARD OPERATING PROCEDURE
INTERIOR SURFACE DUST SAMPLING AT RESIDENCES**

**Figure 2
INDOOR DUST FIELD DATA SHEET**

SITE: _____	SAMPLE NUMBER <div style="border: 1px solid black; width: 100%; height: 100%;"></div>
COLLECTION METHOD: <u>SOP SRC-DUST-01 (Rev. 0)</u>	
SAMPLING DATE: _____	
SAMPLE TEAM ID: _____	
ADDRESS: _____	
	<i>House# Street Name</i>
SAMPLE CLASS:	FS (Field Sample) EB (Equipment Blank)
TEMPLATE SIZE: _____	4 ft ²

TEMPLATE COLLECTION LOCATIONS:

Number	Living Area (a)	Surface Type (b)	Notes
1			
2			
3			
4			
5			
6			
7			
8			
9			
10			
11			
12			
13			
14			
15			
16			
17			
18			

(a) Living Area Codes:
BR = bedroom
FR = family room / living room
K = kitchen
D = dining / eating area
H = hall way

(b) Surface Types:
H = hard (linoleum, stone, wood, etc.)
S = soft (carpet, rug, etc.)
O = other (note which) _____