



UNITED STATES ENVIRONMENTAL PROTECTION AGENCY
OFFICE OF AIR AND RADIATION
NATIONAL VEHICLE AND FUEL EMISSIONS LABORATORY
2000 TRAVERWOOD DRIVE
ANN ARBOR, MI 48105-2498

February 2020

MEMORANDUM

SUBJECT: Redline Version of EPA's Proposed Regulations to Adopt New Standards for Heavy-Duty Engine and Vehicle Standards and Other Amendments

FROM: Alan Stout, Staff Engineer
Assessment and Standards Division

Jessica Brakora, Staff Engineer
Assessment and Standards Division

TO: Docket EPA-HQ-OAR-2019-0055

EPA is proposing to update the emission standards, test procedures, useful life, warranty, and other requirements, for heavy-duty highway engines and vehicles. The proposed rule also includes migrating most remaining regulatory provisions from 40 CFR part 86, subpart A, to 40 CFR part 1036.

The proposal also includes amendments for heavy-duty highway engines and vehicles and most other types of engines, vehicles, and equipment that are subject to EPA emission standards, such as light-duty motor vehicles, marine diesel engines, locomotives, other nonroad and stationary applications, and portable fuel containers. The attached file is a redline version of the proposed amendments showing changes to existing text in the *Code of Federal Regulations*.

The regulatory text in the attached file is intended to be the same as what will be published in the *Federal Register*. However, it is possible that there will be some minor differences. The document published in the *Federal Register* is the official copy for purposes of proposal and comment.

Attachment

CONTENTS

PART 2—PUBLIC INFORMATION	3
PART 59—NATIONAL VOLATILE ORGANIC COMPOUND EMISSION STANDARDS FOR CONSUMER AND COMMERCIAL PRODUCTS	5
PART 60—STANDARDS OF PERFORMANCE FOR NEW STATIONARY SOURCES	6
PART 80—REGULATION OF FUELS AND FUEL ADDITIVES	7
PART 85—CONTROL OF AIR POLLUTION FROM MOBILE SOURCES	8
PART 86—CONTROL OF EMISSIONS FROM NEW AND IN-USE HIGHWAY VEHICLES AND ENGINES	14
PART 87—CONTROL OF AIR POLLUTION FROM AIRCRAFT AND AIRCRAFT ENGINES	24
PART 600—FUEL ECONOMY AND GREENHOUSE GAS EXHAUST EMISSIONS OF MOTOR VEHICLES	25
PART 1030—CONTROL OF GREENHOUSE GAS EMISSIONS FROM ENGINES INSTALLED ON AIRPLANES	35
PART 1033—CONTROL OF EMISSIONS FROM LOCOMOTIVES	36
PART 1036--CONTROL OF EMISSIONS FROM NEW AND IN-USE HEAVY-DUTY HIGHWAY ENGINES	42
PART 1037—CONTROL OF EMISSIONS FROM NEW HEAVY-DUTY MOTOR VEHICLES	278
PART 1039—CONTROL OF EMISSIONS FROM NEW AND IN-USE NONROAD COMPRESSION-IGNITION ENGINES	333
PART 1042—CONTROL OF EMISSIONS FROM NEW AND IN-USE MARINE COMPRESSION-IGNITION ENGINES AND VESSELS	336
PART 1043—CONTROL OF NOX, SOX, AND PM EMISSIONS FROM MARINE ENGINES AND VESSELS SUBJECT TO THE MARPOL PROTOCOL	345
PART 1045—CONTROL OF EMISSIONS FROM SPARK-IGNITION PROPULSION MARINE ENGINES AND VESSELS	347
PART 1048—CONTROL OF EMISSIONS FROM NEW, LARGE NONROAD SPARK- IGNITION ENGINES	349
PART 1051—CONTROL OF EMISSIONS FROM RECREATIONAL ENGINES AND VEHICLES	352
PART 1054—CONTROL OF EMISSIONS FROM NEW, SMALL NONROAD SPARK- IGNITION ENGINES AND EQUIPMENT	355
PART 1060—CONTROL OF EVAPORATIVE EMISSIONS FROM NEW AND IN-USE NONROAD AND STATIONARY EQUIPMENT	361
PART 1065—ENGINE-TESTING PROCEDURES	362
PART 1066—VEHICLE-TESTING PROCEDURES	407
PART 1068—GENERAL COMPLIANCE PROVISIONS FOR HIGHWAY, STATIONARY, AND NONROAD PROGRAMS	414
PART 1090—REGULATION OF FUELS, FUEL ADDITIVES, AND REGULATED BLENDSTOCKS	428

PART 2—PUBLIC INFORMATION

1. The authority citation for part 2 continues to read as follows:
Authority: 5 U.S.C. 552, 552a, 553; 28 U.S.C. 509, 510, 534; 31 U.S.C. 3717.

2. Amend §2.301 by adding and reserving paragraph (i) and adding paragraph (j) to read as follows:

§ 2.301 Special rules governing certain information obtained under the Clean Air Act.

* * * * *

(i) [Reserved]

(j) Requests for or release of information subject to a confidentiality determination through rulemaking as specified in 40 CFR part 1068. This paragraph (j) describes provisions that apply for a wide range of engines, vehicles, and equipment that are subject to emission standards and other requirements under the Clean Air Act. This includes motor vehicles and motor vehicle engines, nonroad engines and nonroad equipment, aircraft and aircraft engines, and stationary engines. It also includes portable fuel containers regulated under 40 CFR part 59, subpart F, and fuel tanks, fuel lines, and related fuel-system components regulated under 40 CFR part 1060. Regulatory provisions related to confidentiality determinations for these products are codified broadly in 40 CFR part 1068, with additional detailed provisions for specific sectors in the regulatory parts referenced in 40 CFR 1068.1. References in this paragraph (j) to 40 CFR part 1068 also include these related regulatory parts.

(1) Unless noted otherwise, 40 CFR 2.201 through 2.215 do not apply for information covered by the confidentiality determinations in 40 CFR part 1068 if EPA has determined through rulemaking that information to be any of the following pursuant to 42 U.S.C. 7414 or 7542(c) in a rulemaking subject to 42 U.S.C. 7607(d):

(i) Emission data as defined in paragraph (a)(2)(i) of this section.

(ii) Data not entitled to confidential treatment.

(2) Unless noted otherwise, 40 CFR 2.201 through 2.208 do not apply for information covered by the confidentiality determinations in 40 CFR part 1068 if EPA has determined through rulemaking that information to be entitled to confidential treatment pursuant to 42 U.S.C. 7414 or 7542(c) in a rulemaking subject to 42 U.S.C. 7607(d). EPA will treat such information as confidential in accordance with the provisions of §2.209 through 2.215, subject to paragraph (j)(4) of this section.

(3) EPA will deny a request for information under 5 U.S.C. 552(b)(4) if EPA has determined through rulemaking that the information is entitled to confidential treatment under 40 CFR part 1068. The denial notification will include a regulatory cite to the appropriate determination.

(4) A determination made pursuant to 42 U.S.C. 7414 or 7542 in a rulemaking subject to 42 U.S.C. 7607(d) that information specified in 40 CFR part 1068 is entitled to confidential treatment shall continue in effect unless EPA takes one of the following actions to modify the determination:

(i) EPA determines, pursuant to 5 U.S.C. 552(b)(4) and the Clean Air Act (42 U.S.C. 7414; 7542(c)) in a rulemaking subject to 42 U.S.C. 7607(d), that the information is entitled to confidential treatment, or that the information is emission data or data that is otherwise not entitled to confidential treatment by statute or regulation.

(ii) EPA determines, pursuant to 5 U.S.C. 552(b)(4) and the Clean Air Act (42 U.S.C. 7414; 7542(c)) that the information is emission data or data that is otherwise clearly not entitled to confidential treatment by statute or regulation under 40 CFR 2.204(d)(2).

(iii) The Office of General Counsel revisits an earlier determination, pursuant to 5 U.S.C. 552(b)(4) and the Clean Air Act (42 U.S.C. 7414; 7542(c)), that the information is entitled to confidential treatment because of a change in the applicable law or newly discovered or changed facts. Prior to a revised final determination, EPA shall afford the business an opportunity to submit a substantiation on the pertinent issues to be considered, including any described in §§2.204(e)(4) or 2.205(b), within 15 days of the receipt of the notice to substantiate. If, after consideration of any timely comments made by the business in its substantiation, the Office of General Counsel makes a revised final determination that the information is not entitled to confidential treatment under 42 U.S.C. 7414 or 7542, EPA will notify the business in accordance with §2.205(f)(2).

(5) The provisions of 40 CFR 2.201 through 2.208 continue to apply for the categories of information identified in 40 CFR 1068.11(c) for which there is no confidentiality determination in 40 CFR part 1068.

PART 59—NATIONAL VOLATILE ORGANIC COMPOUND EMISSION STANDARDS FOR CONSUMER AND COMMERCIAL PRODUCTS

3. The authority citation for part 59 continues to read as follows:
Authority: 42 U.S.C. 7414 and 7511b(e).

4. Revise §59.695 to read as follows:

§ 59.695 What provisions apply to confidential information?

The provisions of 40 CFR 1068.10 and 1068.11 apply for submitted information you claim as confidential information you submit under this part.

~~(a) Clearly show what you consider confidential by marking, circling, bracketing, stamping, or some other method.~~

~~(b) We will store your confidential information as described in 40 CFR part 2. Also, we will disclose it only as specified in 40 CFR part 2. This applies both to any information you send us and to any information we collect from inspections, audits, or other site visits.~~

~~(c) If you send us a second copy without the confidential information, we will assume it contains nothing confidential whenever we need to release information from it.~~

~~(d) If you send us information without claiming it is confidential, we may make it available to the public without further notice to you, as described in 40 CFR 2.204.~~

PART 60—STANDARDS OF PERFORMANCE FOR NEW STATIONARY SOURCES

5. The authority citation for part 60 continues to read as follows:
Authority: 42 U.S.C. 7401 et seq.

6. Amend §60.4202 by revising paragraph (g) introductory text to read as follows:

§ 60.4202 What emission standards must I meet for emergency engines if I am a stationary CI internal combustion engine manufacturer?

* * * * *

(g) Notwithstanding the requirements in paragraphs (a) through (d) of this section, stationary emergency CI ICE identified in paragraphs (a) and (c) of this section may be certified to the provisions of 40 CFR part 1042 for commercial engines that are applicable for the engine's model year, displacement, power density, and maximum engine power if the engines will be used solely in either or both of the locations identified in paragraphs (g)(1) and (2) of this section. Engines that would be subject to the Tier 4 standards in 40 CFR part 1042 that are used solely in either or both of the locations identified in paragraphs (g)(1) and (2) of this section may instead continue to be certified to the appropriate Tier 3 previous tier of standards in 40 CFR part 1042. The previous tier is Tier 3 in most cases; however, the previous tier is Tier 2 if there are no Tier 3 standards specified for engines of a certain size or power rating.

* * * * *

7. Revise §60.4218 to read as follows:

§ 60.4218 What ~~parts of the~~ General Provisions and confidential information provisions apply to me?

(a) Table 8 to this subpart shows which parts of the General Provisions in §§60.1 through 60.19 apply to you.

(b) The provisions of 40 CFR 1068.10 and 1068.11 apply for engine manufacturers. For others, the general confidential business information (CBI) provisions apply as described in 40 CFR part 2.

8. Revise §60.4246 to read as follows:

§ 60.4246 What ~~parts of the~~ General Provisions and confidential information provisions apply to me?

(a) Table 3 to this subpart shows which parts of the General Provisions in §§60.1 through 60.19 apply to you.

(b) The provisions of 40 CFR 1068.10 and 1068.11 apply for engine manufacturers. For others, the general confidential business information (CBI) provisions apply as described in 40 CFR part 2.

PART 80—REGULATION OF FUELS AND FUEL ADDITIVES

9. The authority citation for part 80 continues to read as follows:
Authority: 42 U.S.C. 7414, 7521, 7542, 7545, and 7601(a).

Subpart B—[Removed and reserved]

10. Remove and reserve subpart B.

PART 85— CONTROL OF AIR POLLUTION FROM MOBILE SOURCES

11. The authority citation for part 85 continues to read as follows:
Authority: 42 U.S.C. 7401-7671q.

12. Amend §85.1501 by revising paragraph (a) to read as follows:

§ 85.1501 Applicability.

(a) Except where otherwise indicated, this subpart is applicable to motor vehicles offered for importation or imported into the United States for which the Administrator has promulgated regulations under 40 CFR part 86, subpart D or S, prescribing emission standards, but which are not covered by certificates of conformity issued under section 206(a) of the Clean Air Act (i.e., which are nonconforming vehicles as defined in § 85.1502), as amended, and part 86 at the time of conditional importation. Compliance with regulations under this subpart shall not relieve any person or entity from compliance with other applicable provisions of the Clean Air Act. This subpart no longer applies for heavy-duty engines certified under 40 CFR part 86, subpart A, or 40 CFR part 1036; references in this subpart to “engines” therefore apply only for replacement engines intended for installation in motor vehicles that are subject to this subpart.

* * * * *

§ 85.1513—[Amended]

13. Amend §85.1513 by removing and reserving paragraph (e)(5).

14. Revise §85.1514 to read as follows:

§ 85.1514 Treatment of confidential information.

The provisions of 40 CFR 1068.10 and 1068.11 apply for information you submit under this subpart~~consider confidential~~.

15. Amend §85.1515 by revising paragraph (a)(2)(ii)(A) to read as follows:

§ 85.1515 Emission standards and test procedures applicable to imported nonconforming motor vehicles and motor vehicle engines.

(a) * * *

(2) * * *

(ii) * * *

(A) *Exhaust and fuel economy tests.* You must measure emissions over the FTP driving cycle and the highway fuel economy driving cycle as specified in 40 CFR ~~600.109~~1066.801 to meet the fuel economy requirements in 40 CFR part 600 and demonstrate compliance with the exhaust emission standards in 40 CFR part 86 (other than PM). Measure exhaust emissions and fuel economy with the same test procedures used by the original manufacturer to test the vehicle for certification. However, you must use an electric dynamometer meeting the requirements of ~~§86.108 or~~ 40 CFR part 1066, subpart B, unless we approve a different dynamometer based on excessive compliance costs. If you certify based on testing with a different dynamometer, you must state in the application for certification that all vehicles in the emission family will comply with emission standards if tested on an electric dynamometer.

* * * * *

16. Amend §85.1701 by revising paragraph (a)(1), (b), and (c) to read as follows:

§ 85.1701 General applicability.

(a) * * *

(1) Beginning January 1, 2014, the exemption provisions of 40 CFR part 1068, subpart C, apply instead of the provisions of this subpart for heavy-duty motor vehicle engines and heavy-duty motor vehicles regulated under 40 CFR part 86, subpart A, or 40 CFR part 1036 or part 1037, except that the nonroad competition exemption of 40 CFR 1068.235 and the nonroad hardship exemption provisions of 40 CFR 1068.245, 1068.250, and 1068.255 do not apply for motor vehicle engines. Note that the provisions for emergency vehicle field modifications in § 85.1716 continue to apply for heavy-duty engines.

* * * * *

(b) The provisions of 40 CFR 1068.10 and 1068.11 apply for information you submit under this subpart.

(c) References to engine families and emission control systems in this subpart or in 40 CFR part 1068 apply to durability groups and test groups as applicable for manufacturers certifying vehicles under the provisions of 40 CFR part 86, subpart S.

* * * * *

§ 85.1712—[Removed and Reserved]

17. Remove and reserve §85.1712.

18. Revise §85.1808 to read as follows:

§ 85.1808 Treatment of confidential information.

The provisions of 40 CFR 1068.10 and 1068.11 apply for information you submit under this subpart~~consider confidential~~.

19. Amend §85.1901 by revising paragraph (a) to read as follows:

§ 85.1901 Applicability.

(a) The requirements of this subpart shall be applicable to all 1972 and later model year motor vehicles and motor vehicle engines, except that the provisions of 40 CFR 1068.501 apply instead for heavy-duty motor vehicle engines and heavy-duty motor vehicles certified under 40 CFR part 86, subpart A, or 40 CFR part 1036 or 1037~~and for heavy-duty motor vehicles certified under 40 CFR part 1037~~ starting January 1, 2018.

* * * * *

20. Revise §85.1909 to read as follows:

§ 85.1909 Treatment of confidential information.

The provisions of 40 CFR 1068.10 and 1068.11 apply for information you submit under this subpart.

Subpart V—~~EMISSIONS CONTROL SYSTEM PERFORMANCE~~ WARRANTY REGULATIONS AND VOLUNTARY AFTERMARKET PART CERTIFICATION PROGRAM

21. The heading of subpart V is revised to read as set forth above.

22. Amend §85.2102 by revising paragraphs (a)(1), (2), (4)-(6), (10), and (13) to read as follows:

§ 85.2102 Definitions.

(a) * * *

(1) *Act* means Part A of Title II of the Clean Air Act, 42 U.S.C. 7421 *et seq.* ~~(formerly 42 U.S.C. 1857 *et seq.*), as amended.~~

(2) *Office Director* means the Director for the Office of Transportation and Air Quality in the Mobile Sources—Office of Air and Radiation of the Environmental Protection Agency or other authorized representative of the Office Director.

* * * * *

(4) *Emission performance warranty* means that warranty given pursuant to this subpart and 42 U.S.C. 7541(b) section 207(b) of the Act.

(5) *Emission warranty* means a warranty given pursuant to this subpart and 42 U.S.C. 7541(a) or (b). *Office Director approved emission test* or *Emission Short Test* means any test prescribed under 40 CFR 85.2201 *et seq.*, and meeting all of the requirements thereunder.

(6) *Model year* means the manufacturer's annual production period as described in subpart X of this part. (as determined by the Office Director) which includes January 1 of such calendar year; however, if the manufacturer has no annual production period, the term "model year" shall mean the calendar year.

* * * * *

(10) *Useful life* means that period established pursuant to 42 U.S.C. 7521(d) section 202(d) of the Act and regulations promulgated thereunder.

* * * * *

(13) *Written instructions for proper maintenance and use* means those maintenance and operation instructions specified in the owner's manual as being necessary to assure compliance of a vehicle with applicable emission standards for the useful life of the vehicle that are:

(i) In accordance with the instructions specified for performance on the manufacturer's prototype vehicle used in certification (including those specified for vehicles used under special circumstances); and

(ii) In compliance with the requirements of 40 CFR ~~86.094-38 or 86.1808-01~~ (as appropriate for the applicable model year vehicle/engine classification); and

(iii) In compliance with any other EPA regulations ~~promulgated by the Office Director~~ governing maintenance and use instructions.

* * * * *

23. Amend §85.2103 by revising paragraph (a)(3) to read as follows:

§ 85.2103 Emission performance warranty.

(a) * * *

(3) Such nonconformity results or will result in the vehicle owner having to bear any penalty or other sanction (including the denial of the right to use the vehicle) under local, State or Federal law, then the manufacturer shall remedy the nonconformity at no cost to the owner; *except that*, if the vehicle has been in operation for more than 24 months or 24,000 miles, the manufacturer shall be required to remedy only those nonconformities resulting from the failure of any of the specified major emission control components listed in 42 U.S.C. 7541(i)(2) or components which have been ~~installed in or on the vehicle for the sole or primary purpose of reducing vehicle~~

emissions and that were not in general use prior to model year 1968 designated by the Administrator to be specified major emission control components until the vehicle has been in operation for 8 years or 80,000 miles.

* * * * *

24. Amend §85.2104 by revising paragraphs (a) and (h) introductory text to read as follows:

§ 85.2104 Owners' compliance with instructions for proper maintenance and use.

(a) An emission ~~performance~~ warranty claim may be denied on the basis of noncompliance by a vehicle owner with the written instructions for proper maintenance and use.

* * * * *

(h) In no case may a manufacturer deny an emission ~~performance~~ warranty claim on the basis of ~~—~~:

* * * * *

25. Amend §85.2106 by revising paragraphs (b) introductory text, (c), (d) introductory text, (d)(2), and (g) to read as follows:

§ 85.2106 Warranty claim procedures.

* * * * *

(b) A ~~warranty~~ claim under any emission warranty required by 42 U.S.C. 7541(a) or (b) may be submitted by bringing a vehicle to:

* * * * *

(c) To the extent required by any Federal or State law, whether statutory or common law, a vehicle manufacturer shall be required to provide a means for non-franchised repair facilities to perform emission ~~performance~~ warranty repairs.

(d) The manufacturer of each vehicle to which the warranty is applicable shall establish procedures as to the manner in which a claim under the emission ~~performance~~ warranty is to be processed. The procedures shall ~~—~~:

* * * * *

(2) Require that if the facility at which the vehicle is initially presented for repair is unable for any reason to honor the particular claim, then, unless this requirement is waived in writing by the vehicle owner, the repair facility shall forward the claim to an individual or office authorized to make emission ~~performance~~ warranty determinations for the manufacturer.

* * * * *

(g) The vehicle manufacturer shall incur all costs associated with a determination that an emission ~~performance~~ warranty claim is valid.

26. Amend §85.2107 by revising paragraphs (a) and (b) to read as follows:

§ 85.2107 Warranty remedy.

(a) The manufacturer's obligation under the emission warranties provided under 42 U.S.C. 7541(a) and (b) shall be to make all adjustments, repairs or replacements necessary to assure that the vehicle complies with applicable emission standards of the U.S. Environmental Protection Agency, that it will continue to comply for the remainder of its useful life (if proper maintenance and operation are continued), and that it will operate in a safe manner. The manufacturer shall bear all costs incurred as a result of the above obligation, *except that* after the first 24 months or 24,000 miles (whichever first occurs) the manufacturer shall be responsible only for:

(1) The adjustment, repair or replacement of any of the specified major emission control components listed in 42 U.S.C. 7541(i)(2) or components which have been designated by the

administrator to be specified major emission control components until the vehicle has been in operation for 8 years or 80,000 miles; and those components which have been installed in or on a vehicle for the sole or primary purpose of reducing vehicle emissions, and which were not in general use prior to model year 1968; and

(2) All other components which must be adjusted, repaired or replaced to enable a component adjusted, repaired, or replaced under paragraph (a)(1) of this section to perform properly.

(b) ~~Under the Emissions Performance Warranty, the m~~Manufacturers shall be liable for the total cost of the remedy for any vehicle validly presented for repair under an emission warranty to any authorized service facility authorized by the vehicle manufacturer. State or local limitations as to the extent of the penalty or sanction imposed upon an owner of a failed vehicle shall have no bearing on this liability.

* * * * *

27. Amend §85.2109 by revising paragraphs (a) introductory text and (a)(6) to read as follows:

§ 85.2109 Inclusion of warranty provisions in owners' manuals and warranty booklets.

(a) A manufacturer shall furnish with each new motor vehicle, a full explanation of the ~~e~~Emission ~~Performance Warranty~~warranties required by 42 U.S.C. 7541(a) and (b), including at a minimum the following information:

* * * * *

(6) An explanation that an owner may obtain further information concerning the emission ~~performance warranty~~warranties or that an owner may report violations of the terms of the Emission ~~Performance Warranty~~warranties provided under 42 U.S.C. 7541(a) and (b) by contacting the Director, ~~Field Operations and Support~~Compliance Division ~~(6406J)~~, Environmental Protection Agency, 401 "M" Street, SW., Washington, DC 20460-2000 Traverwood Dr, Ann Arbor, MI 48105 (Attention: ~~Warranty Claim~~) or email to: complianceinfo@epa.gov.

* * * * *

28. Amend §85.2111 by revising the introductory text and paragraphs (b) introductory text, (c), and (d) to read as follows:

§ 85.2111 Warranty enforcement.

The following acts are prohibited and may subject a manufacturer to ~~up to a \$32,500 civil penalty for each offense, except as noted~~ a civil penalty as described in paragraph (d) of this section:

* * * * *

(b) Failing or refusing to comply with the terms and conditions of the ~~Emission Performance Warranties~~ required by emission warranties provided under 42 U.S.C. 7541(a) and (b) with respect to any vehicle to which this subpart applies. Acts constituting such a failure or refusal shall include, but are not limited to, the following:

* * * * *

(c) To provide directly or indirectly in any communication to the ultimate purchaser or any subsequent purchaser that ~~the emission performance~~warranty coverage is conditioned upon the use of any name brand ~~part~~, component, or system or upon service (other than a component or service provided without charge under the terms of the purchase agreement), unless the communication is made pursuant to a written waiver by the Office Director.

(d) The maximum penalty value is \$37,500 for each offense that occurs after November 2, 2015~~listed in this section is shown for calendar year 2004~~. Maximum penalty limits ~~for later years~~ may be adjusted based on the Consumer Price Index as described at 40 CFR part 19. ~~The specific regulatory provisions for changing the maximum penalties, published in 40 CFR part 19, reference the applicable U.S. Code citation on which the prohibited action is based.~~

* * * * *

29. Revise §85.2123 to read as follows:

§ 85.2123 Treatment of confidential information.

The provisions of 40 CFR 1068.10 and 1068.11 apply for information you submit under this subpart.

PART 86— CONTROL OF EMISSIONS FROM NEW AND IN-USE HIGHWAY VEHICLES AND ENGINES

30. The authority citation for part 86 continues to read as follows:
Authority: 42 U.S.C. 7401-7671q.

31. Amend § 86.007-11 by revising paragraphs (f) and (g) introductory text to read as follows:

§ 86.007-11 Emission standards and supplemental requirements for 2007 and later model year diesel heavy-duty engines and vehicles.

* * * * *

(f)(1) Model year 2007 and later diesel-fueled heavy-duty engines and vehicles for sale in Guam, American Samoa, or the Commonwealth of the Northern Mariana Islands may be subject to alternative standards under 40 CFR 1036.655. ~~shall be subject to the same standards and requirements as apply to 2006 model year diesel heavy-duty engines and vehicles, but only if the vehicle or engine bears a permanently affixed label stating:~~

~~THIS ENGINE (or VEHICLE, as applicable) CONFORMS TO US EPA EMISSION STANDARDS APPLICABLE TO MODEL YEAR 2006. THIS ENGINE (or VEHICLE, as applicable) DOES NOT CONFORM TO US EPA EMISSION REQUIREMENTS IN EFFECT AT TIME OF PRODUCTION AND MAY NOT BE IMPORTED INTO THE UNITED STATES OR ANY TERRITORY OF THE UNITED STATES EXCEPT AMERICAN SAMOA OR THE COMMONWEALTH OF THE NORTHERN MARIANA ISLANDS.~~

~~(2) The importation or sale of such a vehicle or engine for use at any U.S. location other than American Samoa or the Commonwealth of the Northern Mariana Islands shall be considered a violation of 42 U.S.C. 7522 (a)(1). In addition, vehicles or vehicle engines subject to this exemption may not subsequently be imported or sold into any state or territory of the United States other than American Samoa or the Commonwealth of the Northern Mariana Islands.~~

(g) Model years 2018 through 2026 and later engines at or above 56 kW that will be installed in specialty vehicles as allowed by 40 CFR 1037.605 may meet alternate emission standards as follows:

* * * * *

32. Amend § 86.008-10 by revising paragraph (g) introductory text to read as follows:

§ 86.008-10 Emission standards for 2008 and later model year Otto-cycle heavy-duty engines and vehicles.

* * * * *

(g) Model years 2018 through 2026 and later engines that will be installed in specialty vehicles as allowed by 40 CFR 1037.605 may meet alternate emission standards as follows:

* * * * *

33. Amend § 86.010-18 by:

- a. Revising paragraph (a) introductory text.
- b. Removing and reserving paragraph (o)

The revision reads as follows:

§ 86.010-18 On-board Diagnostics for engines used in applications greater than 14,000

pounds GVWR.

(a) *General.* According to the implementation schedule shown in paragraph (o) of this section, ~~h~~Heavy-duty engines intended for use in a heavy-duty vehicle weighing more than 14,000 pounds GVWR must be equipped with an on-board diagnostic (OBD) system capable of monitoring all emission-related engine systems or components during the life of the engine. The OBD requirements of 40 CFR 1036.110 apply starting in model year 2027. In earlier model years, manufacturers may meet the requirements of this section or the requirements of 40 CFR 1036.110. Note that 40 CFR 1036.150(u) allows for an alternative communication protocol before model year 2027. The OBD system is required to detect all malfunctions specified in paragraphs (g), (h), and (i) of this ~~section even §86.010-18 a~~lthough the OBD system is not required to use a unique monitor to detect each of those malfunctions.

* * * * *

34. Amend § 86.016-1 by:

- a. Revising paragraphs (a) introductory text, (d) introductory text, and (d)(4).
- b. Adding and reserving paragraph (i).
- c. Adding paragraph (j).

The revisions and additions read as follows:

§ 86.016-1 General applicability.

(a) *Applicability.* The provisions of this subpart apply for certain types of new heavy-duty engines and vehicles as described in this ~~section paragraph (a).~~ As described in paragraph (j) of this section, most of this subpart no longer applies starting with model year 2027. Note that this subpart does not apply for light-duty vehicles, light-duty trucks, ~~or~~ medium-duty passenger vehicles, or vehicles at or below 14,000 pounds GVWR that have no propulsion engine, such as electric vehicles; (see subpart S of this part for requirements that apply for those vehicles). In some cases, manufacturers of heavy-duty engines and vehicles can choose ~~whether~~ to meet the requirements of this subpart or the requirements of subpart S of this part; those provisions are therefore considered optional, but only to the extent that manufacturers comply with the other set of requirements. In cases where a provision applies only for a certain vehicle group based on its model year, vehicle class, motor fuel, engine type, or other distinguishing characteristics, the limited applicability is cited in the appropriate section. The provisions of this subpart apply for certain heavy-duty engines and vehicles as follows:

* * * * *

(d) *Non-petroleum fueled vehicles.* ~~The s~~Standards and requirements ~~of this part~~ apply to model year 2016 and later non-petroleum fueled motor vehicles as follows:

* * * * *

(4) The standards and requirements of 40 CFR part 1037 apply for vehicles above 14,000 pounds GVWR that have no propulsion engine, such as electric vehicles. ~~subpart S of this part applicable to heavy-duty vehicles under 14,000 pounds GVWR apply to all heavy-duty vehicles powered solely by electricity, including plug-in electric vehicles and solar-powered vehicles. Use good engineering judgment to apply these requirements to these vehicles, including applying these provisions to vehicles over 14,000 pounds GVWR. Electric heavy-duty vehicles may not generate PM emission credits.~~ Electric heavy-duty vehicles may not generate NO_x ~~or PM~~ emission credits except as allowed under 40 CFR part 1037. ~~Heavy-duty vehicles powered solely by electricity are deemed to have zero emissions of regulated pollutants.~~

* * * * *

(i) [Reserved]

(j) Transition to 40 CFR parts 1036 and 1037. Except for § 86.010-38(j), this subpart no longer applies starting with model year 2027. Individual provisions in 40 CFR parts 1036 and 1037 apply instead of the provisions of this subpart before model year 2027 as specified in this subpart and 40 CFR parts 1036 and 1037.

35. Amend § 86.090-5 by adding paragraph (b)(4) to read as follows.

§ 86.090-5 General standards; increase in emissions; unsafe conditions.

* * * * *

(b) * * *

(4) Manufacturers of engines equipped with vanadium-based SCR catalysts must design the engine and its emission controls to prevent vanadium sublimation and protect the catalyst from high temperatures as described in 40 CFR 1036.115(g)(2).

36. Amend § 86.117-96 by revising paragraph (d)(1) introductory text and adding paragraphs (d)(1)(iii) and (iv) to read as follows.

§ 86.117-96 Evaporative emission enclosure calibrations.

* * * * *

(d) * * *

(1) The calculation of net methanol and hydrocarbon mass change is used to determine enclosure background and leak rate. It is also used to check the enclosure volume measurements. The methanol mass change is calculated from the initial and final methanol samples, the net withdrawn methanol (in the case of diurnal emission testing with fixed-volume enclosures), and initial and final temperature and pressure according to the following equation:

$$M_{\text{CH}_3\text{OH}} = V_n \times \left[\frac{(TE_f \times (C_{\text{MS1f}} \times AV_{1f}) + (C_{\text{MS2f}} \times AV_{2f}))}{V_{\text{Ef}} \times T_{\text{SHEDf}}} \right] - \left[\frac{(TE_i \times (C_{\text{MS1i}} \times AV_{1i}) + (C_{\text{MS2i}} \times AV_{2i}))}{V_{\text{Ei}} \times T_{\text{SHEDi}}} \right] + (M_{\text{CH}_3\text{OH,out}} - M_{\text{CH}_3\text{OH,in}})$$

* * * * *

(iii) TE = temperature of sample withdrawn, R.

(iv) T_{SHED} = temperature of SHED, R.

* * * * *

37. Add § 86.450 to subpart E to read as follows:

§ 86.450 Treatment of confidential information.

The provisions of 40 CFR 1068.10 and 1068.11 apply for information you submit under this subpart.

Subpart I—[Removed and Reserved]

38. Subpart I is removed and reserved.

39. Add § 86.1117 to subpart L to read as follows:

§ 86.1117 Labeling.

(a) Light-duty trucks and heavy-duty vehicles and engines for which nonconformance penalties are to be paid in accordance with § 86.1113-87(b) must have information printed on the emission control information label or a supplemental label as follows.

(1) The manufacturer must begin labeling production engines or vehicles within 10 days after the completion of the PCA.

(2) This statement shall read: “The manufacturer of this [engine or vehicle, as applicable] will pay a nonconformance penalty to be allowed to introduce it into U.S. commerce at an emission level higher than the applicable emission standard. The [compliance level or alternative emission standard] for this engine/vehicle is [insert the applicable pollutant and compliance level calculated in accordance with § 86.1112-87(a)].”

(3) If a manufacturer introduces an engine or vehicle into U.S. commerce prior to the compliance level determination of § 86.1112-87(a), it must provide the engine or vehicle owner with a label as described in paragraph (a)(2) of this section to be affixed in a location in proximity to the emission control information label within 30 days of the completion of the PCA.

(b) The Administrator may approve in advance other label content and formats, provided the alternative label contains information consistent with this section.

40. Revise § 86.1301 to read as follows:

§ 86.1301 Scope; applicability.

(a) This subpart specifies gaseous emission test procedures for Otto-cycle and diesel heavy-duty engines, and particulate emission test procedures for diesel heavy-duty engines.

(b) You may optionally demonstrate compliance with the emission standards of this part by testing hybrid engines and hybrid powertrains using the test procedures in 40 CFR part 1036, rather than testing the engine alone. If you choose this option, you may meet the supplemental emission test (SET) requirements by using the SET duty cycle specified in either § 86.1362 or 40 CFR 1036.505. Except as specified, provisions of this subpart and subpart A of this part that reference engines apply equally to hybrid engines and hybrid powertrains.

(c) The abbreviations and acronyms from subpart A of this part apply to this subpart.

§§ 86.1302-84, 86.1303-84, and 86.1304—[Removed]

41. Remove §§ 86.1302-84, 86.1303-84, and 86.1304.

42. Amend § 86.1362 by revising paragraph (b) to read as follows:

§ 86.1362 Steady-state testing with a ramped-modal cycle.

* * * * *

(b) Measure emissions by testing the engine on a dynamometer with the following ramped-modal duty cycle to determine whether it meets the applicable steady-state emission standards in this part and 40 CFR part 1036:

Table 1 of § 86.1362—Ramped-Modal Duty Cycle

RMC Mode	Engine testing			Hybrid powertrain testing									CO ₂ weighting (percent) ⁵
	Time in mode (seconds)	Engine Speed ^{1,2}	Torque (percent) ^{2,3}	Vehicle speed (mi/hr) ⁴	Road-grade coefficients ⁴								
					<i>a</i>	<i>b</i>	<i>c</i>	<i>d</i>	<i>e</i>	<i>f</i>	<i>g</i>	<i>h</i>	
1a Steady-state	170	Warm Idle	0	Warm Idle	0	0	0	0	0	0	0	0	6
1b Transition	20	Linear Transition	Linear Transition	Linear Transition	-1.898E-08	-5.895E-07	3.780E-05	4.706E-03	6.550E-04	-2.679E-02	-1.027E+00	1.542E+01	
2a Steady-state	173	A	100	v _{refA}	-1.235E-08	-5.506E-07	3.954E-05	1.248E-03	5.287E-04	-3.117E-02	-3.263E-01	1.627E+01	9
2b Transition	20	Linear Transition	Linear Transition	Linear Transition	-1.640E-09	-4.899E-07	2.493E-05	5.702E-04	4.768E-04	-2.389E-02	-2.712E-01	1.206E+01	
3a Steady-state	219	B	50	v _{refB}	8.337E-09	-4.758E-07	1.291E-05	2.874E-04	4.528E-04	-1.803E-02	-1.830E-01	8.808E+00	10
3b Transition	20	B	Linear Transition	v _{refB}	4.263E-09	-5.102E-07	2.010E-05	3.703E-04	4.852E-04	-2.242E-02	-2.068E-01	1.074E+01	
4a Steady-state	217	B	75	v _{refB}	1.686E-10	-5.226E-07	2.579E-05	5.521E-04	5.005E-04	-2.561E-02	-2.393E-01	1.285E+01	10
4b Transition	20	Linear Transition	Linear Transition	Linear Transition	6.556E-10	-4.971E-07	2.226E-05	5.293E-04	4.629E-04	-2.185E-02	-1.819E-01	1.086E+01	
5a Steady-state	103	A	50	v _{refA}	3.833E-09	-4.343E-07	1.369E-05	4.755E-04	4.146E-04	-1.605E-02	-1.899E-01	8.200E+00	12
5b Transition	20	A	Linear Transition	v _{refA}	-7.526E-11	-4.680E-07	2.035E-05	7.214E-04	4.478E-04	-2.012E-02	-2.306E-01	1.043E+01	
6a Steady-state	100	A	75	v _{refA}	-4.195E-09	-4.855E-07	2.624E-05	8.345E-04	4.669E-04	-2.338E-02	-2.547E-01	1.215E+01	12
6b Transition	20	A	Linear Transition	v _{refA}	3.185E-09	-4.545E-07	1.549E-05	6.220E-04	4.308E-04	-1.724E-02	-2.093E-01	8.906E+00	
7a Steady-state	103	A	25	v _{refA}	1.202E-08	-3.766E-07	6.943E-07	1.107E-04	3.579E-04	-8.468E-03	-1.243E-01	4.195E+00	12
7b Transition	20	Linear Transition	Linear Transition	Linear Transition	1.481E-09	-5.004E-07	2.151E-05	6.028E-04	4.765E-04	-2.197E-02	-2.669E-01	1.109E+01	
8a Steady-state	194	B	100	v _{refB}	-8.171E-09	-5.682E-07	3.880E-05	8.171E-04	5.462E-04	-3.315E-02	-2.957E-01	1.689E+01	9
8b Transition	20	B	Linear Transition	v _{refB}	3.527E-09	-5.294E-07	2.221E-05	4.955E-04	4.976E-04	-2.363E-02	-2.253E-01	1.156E+01	
9a Steady-state	218	B	25	v _{refB}	1.665E-08	-4.288E-07	-1.393E-07	2.170E-05	4.062E-04	-1.045E-02	-1.266E-01	4.762E+00	9
9b Transition	20	Linear Transition	Linear Transition	Linear Transition	7.236E-09	-5.497E-07	1.998E-05	1.381E-04	5.110E-04	-2.333E-02	-2.154E-01	1.024E+01	

10a Steady-state	171	C	100	v _{refC}	-7.509E-10	-5.928E-07	3.454E-05	5.067E-04	5.670E-04	-3.353E-02	-2.648E-01	1.649E+01	2
10b Transition	20	C	Linear Transition	v _{refC}	1.064E-08	-5.343E-07	1.678E-05	2.591E-04	5.101E-04	-2.331E-02	-2.017E-01	1.119E+01	
11a Steady-state	102	C	25	v _{refC}	2.235E-08	-4.756E-07	-2.078E-06	-6.006E-05	4.509E-04	-1.213E-02	-1.261E-01	5.090E+00	1
11b Transition	20	C	Linear Transition	v _{refC}	1.550E-08	-5.417E-07	1.114E-05	8.438E-05	5.051E-04	-2.005E-02	-1.679E-01	8.734E+00	
12a Steady-state	100	C	75	v _{refC}	7.160E-09	-5.569E-07	2.234E-05	3.107E-04	5.301E-04	-2.644E-02	-2.177E-01	1.266E+01	1
12b Transition	20	C	Linear Transition	v _{refC}	9.906E-09	-5.292E-07	1.694E-05	2.460E-04	5.058E-04	-2.304E-02	-1.990E-01	1.103E+01	
13a Steady-state	102	C	50	v _{refC}	1.471E-08	-5.118E-07	9.881E-06	1.002E-04	4.864E-04	-1.904E-02	-1.678E-01	8.738E+00	1
13b Transition	20	Linear Transition	Linear Transition	Linear Transition	-1.482E-09	-1.992E-06	6.475E-05	-1.393E-02	1.229E-03	-3.967E-02	1.135E+00	-7.267E+00	
14 Steady-state	168	Warm Idle	0	Warm Idle	0	0	0	0	0	0	0	0	6

¹Engine speed terms are defined in 40 CFR part 1065.

²Advance from one mode to the next within a 20 second transition phase. During the transition phase, command a linear progression from the settings of the current mode to the settings of the next mode.

³The percent torque is relative to maximum torque at the commanded engine speed.

⁴See 40 CFR 1036.505(c) for a description of powertrain testing with the ramped-modal cycle, including the equation that uses the road-grade coefficients.

⁵Use the specified weighting factors to calculate composite emission results for CO₂ as specified in 40 CFR 1036.501.

43. Amend § 86.1372 by revising paragraph (a) to read as follows:

§ 86.1372 Measuring smoke emissions within the NTE zone.

* * * * *

(a) For steady-state or transient smoke testing using full-flow opacimeters, equipment meeting the requirements of [40 CFR part 1065, subpart L, subpart I of this part](#) or ISO/DIS-11614 “Reciprocating internal combustion compression-ignition engines - Apparatus for measurement of the opacity and for determination of the light absorption coefficient of exhaust gas” is required. This document is incorporated by reference (see § 86.1).

* * * * *

44. Amend § 86.1801-12 by revising paragraphs (a)(2) introductory text, (a)(2)(iii), (a)(3) introductory text, and (g) to read as follows:

§ 86.1801-12 Applicability.

(a) * * *

(2) The provisions of this subpart apply for medium-duty passenger vehicles and all vehicles at or below 14,000 pounds GVWR that have no propulsion engine, such as electric vehicles. The provisions of this subpart also apply for other complete heavy-duty vehicles at or below 14,000 pounds GVWR, except as follows:

* * * * *

(iii) The provisions of this subpart are optional for diesel-fueled Class 3 heavy-duty vehicles in a given model year if those vehicles are equipped with engines certified to the appropriate standards in § 86.007-11 or 40 CFR 1036.104 for which less than half of the engine family's sales for the model year in the United States are for complete Class 3 heavy-duty vehicles. This includes engines sold to all vehicle manufacturers. If you are the original manufacturer of the engine and the vehicle, base this showing on your sales information. If you manufacture the vehicle but are not the original manufacturer of the engine, you must use your best estimate of the original manufacturer's sales information.

(3) The provisions of this subpart generally do not apply to incomplete heavy-duty vehicles or to complete vehicles above 14,000 pounds GVWR (see [subpart A of this part § 86.016-1](#) and 40 CFR parts 1036 and 1037). However, this subpart applies to such vehicles in the following cases:

* * * * *

(g) *Complete and incomplete vehicles.* Several provisions in this subpart, including the applicability provisions described in this section, are different for complete and incomplete vehicles. We differentiate these vehicle types as described in [40 CFR 1037.801](#) ~~§ 86.085-20~~.

* * * * *

45. Amend § 86.1810-17 by adding paragraph (j) to read as follows:

§ 86.1810-17 General requirements.

* * * * *

(j) Small-volume manufacturers that modify a vehicle already certified by a different company may recertify that vehicle under this subpart S based on the vehicle supplier’s compliance with

fleet average standards for criteria exhaust emissions, evaporative emissions, and greenhouse gas emissions as follows:

(1) The recertifying manufacturer must certify the vehicle at bin levels and family emission limits that are the same as or more stringent than the corresponding bin levels and family emission limits for the vehicle supplier.

(2) The recertifying manufacturer must meet all the standards and requirements described in this subpart S, except for the fleet average standards for criteria exhaust emissions, evaporative emissions, and greenhouse gas emissions.

(3) The vehicle supplier must send the small-volume manufacturer a written statement accepting responsibility to include the subject vehicles in the vehicle supplier's exhaust and evaporative fleet average calculations in §§ 86.1860-17, 86.1864-12, and 86.1865-12.

(4) The small-volume manufacturer must describe in the application for certification how the two companies are working together to demonstrate compliance for the subject vehicles. The application must include the statement from the vehicle supplier described in paragraph (j)(3) of this section.

(5) The vehicle supplier must include a statement that the vehicle supplier is including the small volume manufacturer's sales volume and emissions levels in the vehicle supplier's fleet average reports under §§ 86.1860-17, 86.1864-12, and 86.1865-12.

§ 86.1819—[Removed]

46. Remove § 86.1819.

47. Amend § 86.1819-14 by revising paragraph (d)(12)(i) to read as follows:

§ 86.1819-14 Greenhouse gas emission standards for heavy-duty vehicles.

* * * * *

(d) * * *

(12) * * *

(i) *Configuration* means a subclassification within a test group based on engine code, transmission type and gear ratios, final drive ratio, and other parameters we designate. Engine code means the combination of both “engine code” and “basic engine” as defined for light-duty vehicles in 40 CFR 600.002.

* * * * *

48. Amend § 86.1823-08 by:

- a. Revising paragraph (c)(1)(iv)(A).
- b. Adding paragraph (m) introductory text.
- c. Revising paragraph (m)(1).

The addition and revisions read as follows:

§ 86.1823-08 Durability demonstration procedures for exhaust emissions.

* * * * *

(c) * * *

(1) * * *

(iv)* * *

(A) The simulated test weight will be the equivalent test weight specified in § 86.129 using a weight basis of the loaded vehicle weight for light-duty vehicles and light light-duty trucks, and ALVW for all other vehicles.

* * * * *

(m) *Durability demonstration procedures for vehicles subject to the greenhouse gas exhaust emission standards specified in § 86.1818.* Determine a deterioration factor for each exhaust constituent as described in this paragraph (m) and in 40 CFR 600.113-12(h) through (m) to calculate the composite CREE DF value.

(1) CO₂. (i) Unless otherwise specified under paragraph (m)(1)(ii) or (iii) of this section, manufacturers may use a multiplicative CO₂ deterioration factor of one or an additive deterioration factor of zero to determine full useful life emissions for the FTP and HFET tests.

(ii) Based on an analysis of industry-wide data, EPA may periodically establish and/or update the deterioration factor for CO₂ emissions, including air conditioning and other credit-related emissions. Deterioration factors established and/or updated under this paragraph (m)(1)(ii) will provide adequate lead time for manufacturers to plan for the change.

(iii) For plug-in hybrid electric vehicles and any other vehicle model the manufacturer determines will experience increased CO₂ emissions over the vehicle's useful life, consistent with good engineering judgment, manufacturers must either install aged components on test vehicles as provided in paragraph (f)(2) of this section, determine a deterioration factor based on testing, or provide an engineering analysis that the vehicle is designed such that CO₂ emissions will not increase over the vehicle's useful life. Alternatively, manufacturers may use Manufacturers may test using the whole-vehicle mileage accumulation procedures in § 86.1823-08 (c) or (d)(1) to determine CO₂ deterioration factors, or manufacturers may request prior EPA approval for an alternative durability procedure based on good engineering judgment. In this case, For the testing option, each FTP test performed on the durability data vehicle selected under § 86.1822 must also be accompanied by an HFET test, and combined FTP/HFET CO₂ results determined by averaging the city (FTP) and highway (HFET) CO₂ values, weighted 0.55 and 0.45 respectively. The deterioration factor will be determined for this combined CO₂ value. Calculated multiplicative deterioration factors that are less than one shall be set to equal one, and calculated additive deterioration factors that are less than zero shall be set to zero.

~~(iv) If, in the good engineering judgment of the manufacturer, the deterioration factors determined according to paragraphs (m)(1)(i), (m)(1)(ii), or (m)(1)(iii) of this section do not adequately account for the expected CO₂ emission deterioration over the vehicle's useful life, the manufacturer may petition EPA to request a more appropriate deterioration factor.~~

* * * * *

49. Amend § 86.1843-01 by revising paragraph (f)(2) and adding paragraph (i) to read as follows:

§ 86.1843-01 General information requirements.

* * * * *

(f) * * *

(2) The manufacturer must submit a final update to Part 1 and Part 2 of the Application by May 1 following the end of January 1st of the subsequent model year to incorporate any applicable running changes or corrections which occurred between January 1~~st~~ of the applicable model year and the end of the model year. A manufacturer may request ~~the Administrator to grant~~ an

extension ~~(of no more than 90 days)~~ for submitting ~~submittal of~~ the final update. The request must clearly indicate the circumstances necessitating the extension.

* * * * *

(i) Confidential information. The provisions of 40 CFR 1068.10 and 1068.11 apply for information you submit under this subpart.

50. Amend § 86.1869-12 by revising paragraph (d)(2)(i) to read as follows:

§ 86.1869-12 CO₂ credits for off-cycle CO₂ reducing technologies.

* * * * *

(d) * * *

(2) *Notice and opportunity for public comment.* (i) The Administrator will publish a notice of availability in the Federal Register notifying the public of a manufacturer's proposed alternative off-cycle credit calculation methodology. The notice will include details regarding the proposed methodology but will not include any Confidential Business Information (see 40 CFR 1068.10 and 1068.11). The notice will include instructions on how to comment on the methodology. The Administrator will take public comments into consideration in the final determination and will notify the public of the final determination. Credits may not be accrued using an approved methodology until the first model year for which the Administrator has issued a final approval.

* * * * *

PART 87—CONTROL OF AIR POLLUTION FROM AIRCRAFT AND AIRCRAFT ENGINES

51. The authority citation for part 87 continues to read as follows:
Authority: 42 U.S.C. 7401 et seq.

52. Revise § 87.4 to read as follows:

§ 87.4 ~~[Reserved]~~ Treatment of confidential information.
The provisions of 40 CFR 1068.10 and 1068.11 apply for information you submit under this part.

§ 87.42—[Amended]

53. Amend § 87.42 by removing and reserving paragraph (d).

PART 600—FUEL ECONOMY AND GREENHOUSE GAS EXHAUST EMISSIONS OF MOTOR VEHICLES

54. The authority citation for part 600 continues to read as follows:
Authority: 49 U.S.C. 32901—23919q, Pub. L. 109-58.

55. Amend § 600.001 by removing the paragraph heading from paragraph (e) and adding paragraph (f) to read as follows:

§ 600.001 General applicability.

* * * * *

(f) Unless we specify otherwise, send all reports and requests for approval to the *Designated Compliance Officer* (see § 600.002).

56. Amend § 600.002 by adding a definition for “Designated Compliance Officer” in alphabetical order and revising the definitions for “Engine code”, “SC03”, and “US06” to read as follows:

§ 600.002 Definitions.

* * * * *

Designated Compliance Officer means the Director, Light-Duty Vehicle Center, U.S. Environmental Protection Agency, 2000 Traverwood Drive, Ann Arbor, MI 48105; complianceinfo@epa.gov; www.epa.gov/ve-certification.

* * * * *

Engine code means one of the following:

- (1) For LDV, LDT, and MDPV, *engine code* means a unique combination, within ~~an engine-system combination~~ a test group (as defined in § 86.1803 of this chapter), of displacement, fuel injection (or carburetion or other fuel delivery system), calibration, distributor calibration, choke calibration, auxiliary emission control devices, and other engine and emission control system components specified by the Administrator. For electric vehicles, engine code means a unique combination of manufacturer, electric traction motor, motor configuration, motor controller, and energy storage device.
- (2) For HDV, *engine code* has the meaning given in § 86.1819-14(d)(12) of this chapter.

* * * * *

SC03 means the test procedure specified in 40 CFR 1066.801(c)(2) ~~§86.160 of this chapter~~.

* * * * *

US06 means the test procedure as described in 40 CFR 1066.801(c)(2) ~~§86.159 of this chapter~~.

* * * * *

57. Amend § 600.011 by revising paragraph (c)(2) to read as follows:

§ 600.011 Incorporation by reference.

* * * * *

(c) * * *

(2) SAE J1634, Battery Electric Vehicle Energy Consumption and Range Test Procedure, revised ~~July 2017~~~~October 2012~~, IBR approved for §§ 600.116-12(a), 600.210(d), and 600.311-12(j) and (k).

* * * * *

§§ 600.106-08, 600.108-08, 600.109-08, and 600.110-08—[Removed]

58. Amend subpart B by removing the following sections: §§ 600.106-08, 600.108-08, 600.109-08, and 600.110-08.

59. Amend § 600.111-08 by revising the introductory text to read as follows:

§ 600.111-08 Test procedures.

This section describes test procedures for the FTP, highway fuel economy test (HFET), US06, SC03, and the cold temperature FTP tests. See 40 CFR 1066.801(c) for an overview of these procedures. Perform testing according to test procedures and other requirements contained in this part 600 and in 40 CFR parts ~~86 and~~ 1066, ~~including the provisions of 40 CFR part 86, subparts B, C, and S.~~ This testing includes specifications and procedures for equipment, calibrations, and exhaust sampling. Manufacturers may ~~use~~ certify vehicles based on data collected according to previously published test procedures for model years through 2021. In addition, we may approve the use of previously published test procedures for later model years as an alternative procedure under 40 CFR 1066.10(c). Manufacturers must comply with regulatory requirements during the transition as described in ~~See 40 CFR 86.101 and 86.201 for detailed provisions related to this transition.~~

* * * * *

§ 600.112-08—[Removed]

60. Remove § 600.112-08.

61. Amend § 600.113-12 by revising paragraphs (a)(1), (b)-(d), and (e)(1) to read as follows:

§ 600.113-12 Fuel economy, CO₂ emissions, and carbon-related exhaust emission calculations for FTP, HFET, US06, SC03 and cold temperature FTP tests.

* * * * *

(a) * * *

(1) Calculate the weighted grams/mile values for the FTP test for CO₂, HC, and CO, and where applicable, CH₃OH, C₂H₅OH, C₂H₄O, HCHO, NMHC, N₂O_x and CH₄ as specified in 40 CFR 1066.605~~§86.144-94(b) of this chapter~~. Measure and record the test fuel's properties as specified in paragraph (f) of this section.

* * * * *

(b) Calculate the HFET fuel economy as follows:

(1) Calculate the mass values for the highway fuel economy test for HC, CO_x and CO₂, and where applicable, CH₃OH, C₂H₅OH, C₂H₄O, HCHO, NMHC, N₂O_x and CH₄ as specified in 40 CFR 1066.605~~§86.144-94(b) of this chapter~~. Measure and record the test fuel's properties as specified in paragraph (f) of this section.

(2) Calculate the grams/mile values for the highway fuel economy test for HC, CO_x and CO₂, and where applicable CH₃OH, C₂H₅OH, C₂H₄O, HCHO, NMHC, N₂O_x and CH₄ by dividing the mass values obtained in paragraph (b)(1) of this section, by the actual driving distance, measured in miles, as specified in ~~§86.135 of this chapter~~[40 CFR 1066.840](#).

(c) Calculate the cold temperature FTP fuel economy as follows:

(1) Calculate the weighted grams/mile values for the cold temperature FTP test for HC, CO_x and CO₂, and where applicable, CH₃OH, C₂H₅OH, C₂H₄O, HCHO, NMHC, N₂O_x and CH₄ as specified in ~~§86.144-94(b) of this chapter~~[40 CFR 1066.605](#). ~~For 2008 through 2010 diesel-fueled vehicles, HC measurement is optional.~~

(2) Calculate separately the grams/mile values for the cold transient phase, stabilized phase and hot transient phase of the cold temperature FTP test as specified in ~~§86.244 of this chapter~~[40 CFR 1066.605](#).

(3) Measure and record the test fuel's properties as specified in paragraph (f) of this section.

(d) Calculate the US06 fuel economy as follows:

(1) Calculate the total grams/mile values for the US06 test for HC, CO_x and CO₂, and where applicable, CH₃OH, C₂H₅OH, C₂H₄O, HCHO, NMHC, N₂O_x and CH₄ as specified in ~~§86.144-94(b) of this chapter~~[40 CFR 1066.605](#).

(2) Calculate separately the grams/mile values for HC, CO_x and CO₂, and where applicable, CH₃OH, C₂H₅OH, C₂H₄O, HCHO, NMHC, N₂O_x and CH₄, for both the US06 City phase and the US06 Highway phase of the US06 test as specified in ~~§86.164 of this chapter~~[40 CFR 1066.605 and 1066.831](#). In lieu of directly measuring the emissions of the separate city and highway phases of the US06 test according to the provisions of ~~§86.159 of this chapter~~[40 CFR 1066.831](#), the manufacturer may optionally, with the advance approval of the Administrator and using good engineering judgment, ~~optionally~~ analytically determine the grams/mile values for the city and highway phases of the US06 test. To analytically determine US06 City and US06 Highway phase emission results, the manufacturer shall multiply the US06 total grams/mile values determined in paragraph (d)(1) of this section by the estimated proportion of fuel use for the city and highway phases relative to the total US06 fuel use. The manufacturer may estimate the proportion of fuel use for the US06 City and US06 Highway phases by using modal CO₂, HC, and CO emissions data, or by using appropriate OBD data (e.g., fuel flow rate in grams of fuel per second), or another method approved by the Administrator.

(3) Measure and record the test fuel's properties as specified in paragraph (f) of this section.

(e) * * *

(1) Calculate the grams/mile values for the SC03 test for HC, CO_x and CO₂, and where applicable, CH₃OH, C₂H₅OH, C₂H₄O, HCHO, NMHC, N₂O_x and CH₄ as specified in ~~§86.144-94(b) of this chapter~~[40 CFR 1066.605](#).

* * * * *

62. Amend § 600.115-11 by revising the introductory text to read as follows:

§ 600.115-11 Criteria for determining the fuel economy label calculation method.

This section provides the criteria to determine if the derived 5-cycle method for determining fuel economy label values, as specified in § 600.210-08(a)(2) or (b)(2) or § 600.210-12(a)(2) or (b)(2), as applicable, may be used to determine label values. Separate criteria apply to city and highway fuel economy for each test group. The provisions of this section are optional. If this option is not chosen, or if the criteria provided in this section are not met, fuel economy label

values must be determined according to the vehicle-specific 5-cycle method specified in § 600.210-08(a)(1) or (b)(1) or § 600.210-12(a)(1) or (b)(1), as applicable. However, dedicated alternative-fuel vehicles (other than battery electric vehicles), dual fuel vehicles when operating on the alternative fuel, ~~plug-in hybrid electric vehicles while operating in charge-depleting mode~~, MDPVs, and vehicles imported by Independent Commercial Importers may use the derived 5-cycle method for determining fuel economy label values whether or not the criteria provided in this section are met. Manufacturers may alternatively account for this effect for battery electric vehicles, fuel cell vehicles, and plug-in hybrid electric vehicles (when operating in the charge-depleting mode) by multiplying 2-cycle fuel economy values by 0.7 and dividing 2-cycle CO₂ emission values by 0.7.

* * * * *

63. Amend § 600.116-12 by revising paragraph (a) to read as follows:

§ 600.116-12 Special procedures related to electric vehicles and hybrid electric vehicles.

(a) Determine fuel economy values for electric vehicles as specified in §§ 600.210 and 600.311 using the procedures of SAE J1634 (incorporated by reference in § 600.011). Use the procedures of SAE J1634, Section 8, with the following clarifications and modifications for using this and other sections of SAE J1634:

~~(1) Use one of the following approaches to define end-of-test criteria for vehicles whose maximum speed is less than the maximum speed specified in the driving schedule, where the vehicle's maximum speed is determined, to the nearest 0.1 mph, from observing the highest speed over the first duty cycle (FTP, HFET, etc.):~~

~~(i) If the vehicle can follow the driving schedule within the speed tolerances specified in §86.115 of this chapter up to its maximum speed, the end-of-test criterion is based on the point at which the vehicle can no longer meet the specified speed tolerances up to and including its maximum speed.~~

~~(ii) If the vehicle cannot follow the driving schedule within the speed tolerances specified in §86.115 of this chapter up to its maximum speed, the end-of-test criterion is based on the following procedure:~~

~~(A) Measure and record the vehicle's speed (to the nearest 0.1 mph) while making a best effort to follow the specified driving schedule.~~

~~(B) This recorded sequence of driving speeds becomes the driving schedule for the test vehicle. Apply the end-of-test criterion based on the point at which the vehicle can no longer meet the specified speed tolerances over this new driving schedule. The driving to establish the new driving schedule may be done separately, or as part of the measurement procedure.~~

~~(2) Soak time between repeat duty cycles (four bag FTP, HFET, etc.) may be up to 30 minutes. No recharging may occur during the soak time.~~

(1) Vehicles that cannot complete the Multi-Cycle Range and Energy Consumption Test (MCT) because they are unable travel the distance required to complete the test with a fully charged battery, or they are unable to achieve the maximum speed on either the UDDS or HFEDS (Highway Fuel Economy Drive Cycle also known as the HFET) cycle should seek Administrator approval to use the procedures outlined in SAE J1634 Section 7 Single Cycle Range and Energy Consumption Test (SCT).

(2) The MCT includes the following key-on soak times and key-off soak periods:

(i) As noted in SAE J1634 Section 8.3.4, a 15 second key-on pause is required between UDDS₁ and HFEDS₁, and UDDS₃ and HFEDS₂. The key-on pause is considered a part of the HFEDS₁ and HFEDS₂ drive cycle.

(ii) As noted in SAE J1634 Section 8.3.4, a 10 minute key-off soak period is required between HFEDS₁ and UDDS₂, and HFEDS₂ and UDDS₄.

(iii) A 5-minute minimum key-off soak period is required between UDDS₂ and the first phase of the mid-test constant speed cycle, and UDDS₄ and the first phase of the end-of-test constant speed cycle.

(iv) If multiple phases are required during either the mid-test constant speed cycle or the end-of-test constant speed cycle there must be a minimum 5-minute key-off soak period between each constant speed phase. The key-off soak periods between the constant speed phases may last for up to a maximum of 30 minutes.

(3) As noted in SAE J1634 Section 8.3.4, during all 'key-off' soak periods, the key or power switch must be in the "off" position, the hood must be closed, the test cell fan(s) must be off, and the brake pedal not depressed. For vehicles which do not have a key or power switch the vehicle must be placed in the 'mode' the manufacturer recommends when the vehicle is to be parked and the occupants exit the vehicle.

(4) Either Method 1 or Method 2 described in Appendix A of SAE J1634 may be used to estimate the mid-test constant speed cycle distance (d_M). The mid-test constant speed cycle distance calculation needs to be performed prior to beginning the test and should not use data from the test being performed. If Method 2 is used, multiply the result determined by the Method 2 equation by 0.8 to determine the mid-test constant speed cycle distance (d_M).

(5) Divide the mid-test constant speed cycle distance (d_M) by 65 mph to determine the total time required for the mid-test constant speed cycle. If the time required is one-hour or less the mid-test constant speed cycle can be performed with no key-off soak periods. If the time required is greater than one-hour the mid-test constant speed cycle must be separated into phases such that no phase exceeds more than one-hour. At the conclusion of each mid-test constant speed phase a minimum 5-minute key-off soak will be performed.

(6) Using good engineering judgment determine the end-of-test constant speed cycle distance so that it does not exceed 20% of the total distance driven during the MCT as described in SAE J1634 Section 8.3.3.

(7) Divide the end-of-test constant speed cycle distance (d_E) by 65 mph to determine the total time required for the end-of-test constant speed cycle. If the time required is one-hour or less the end-of-test constant speed cycle can be performed with no key-off soak periods. If the time required is greater than one-hour the end-of-test constant speed cycle must be separated into phases such that no phase exceeds more than one-hour. At the conclusion of each end-of-test constant speed phase a minimum 5-minute key-off soak will be performed.

(8) SAE J634 Section 3.13 defines useable battery energy (UBE) as the total DC discharge energy (Ed_{total}), measured in DC watt-hours for a full discharge test. The total DC discharge energy is the sum of all measured phases of a test inclusive of all drive cycle types. As key-off soak periods are not considered part of the test phase, the discharge energy that occurs during the key-off soak periods is not included in the useable battery energy.

(93) Recharging the vehicle's battery must start within three hours after the end of testing.

(4) Do not apply the C coefficient adjustment specified in Section 4.4.2.

(105) We may approve alternate measurement procedures with respect to electric vehicles if they are necessary or appropriate for meeting the objectives of this part. For example, we At

the request of a manufacturer, the Administrator may approve the use of an earlier version of SAE J1634 when a manufacturer is carrying over data for vehicles tested using a prior version of SAE J1634, ~~or if you show that it is equivalent for your vehicle.~~

(116) All label values related to fuel economy, energy consumption, and range must be based on 5-cycle testing or on values adjusted to be equivalent to 5-cycle results. Prior to performing testing to generate a 5-cycle adjustment factor, manufacturers must request Administrator approval to use SAE J1634 Appendices B and C for determining a 5-cycle adjustment factor with the following modifications, clarifications, and attestations:

(i) The 20 °F charge-depleting UDDS must be performed with a minimum 10-minute key-off soak period between each UDDS cycle. Key-off soak periods of up to 30 minutes are allowed. During all ‘key-off’ soak periods, the key or power switch must be in the “off” position, the hood must be closed, the test cell fan(s) must be off, and the brake pedal not depressed. For vehicles which do not have a key or power switch the vehicle must be placed in the ‘mode’ the manufacturer recommends when the vehicle is to be parked and the occupants exit the vehicle.

(ii) Prior to performing the 20 °F charge-depleting UDDS the vehicle must soak for a minimum of 12 hours and a maximum of 36 hours at a temperature of 20 °F. Prior to beginning the 12 to 36 hour cold soak at 20 °F the vehicle must be fully charged, the charging can take place at test laboratory ambient temperatures (68 to 86 °F) or at 20 °F. During the 12 to 36 hour cold soak period the vehicle may not be connected to a charger nor is the vehicle cabin or battery to be preconditioned during the 20 °F soak period.

(iii) Beginning with the 2024 model year the 20 °F UDDS charge-depleting UDDS test will be replaced with a 20 °F UDDS test consisting of 2 UDDS cycles performed with a 10-minute key-off soak between the two UDDS cycles. The data from the two UDDS cycles will be used to calculate the five-cycle adjustment factor, instead of using the results from the entire charge-depleting data set. Manufacturers that have submitted and used the average data from 20 °F charge-depleting UDDS data sets will be required to revise their 5-cycle adjustment factor calculation and re-label vehicles using the data from the first two UDDS cycles only. Manufacturers, at their discretion, would also be allowed to re-run the 20 °F UDDS test with the battery charged to a state-of-charge (SoC) determined by the manufacturer. The battery does not need to be at 100% SoC before the 20 °F cold soak.

(iv) Manufacturers must submit a written attestation to the Administrator at the completion of testing with the following information:

(A) A statement noting the SoC level of the rechargeable energy storage system (RESS) prior to beginning the 20°F cold soak for testing performed beginning with model year 2024.

(B) A statement confirming the vehicle was not charged or preconditioned during the 12 to 36 hour 20 °F soak period before starting the 20 °F UDDS cycle.

(C) A summary of all the 5-cycle test results and the calculations used to generate the 5-cycle adjustment factor, including all of the 20 °F UDDS cycles, the distance travelled during each UDDS and the measured DC discharge energy during each UDDS phase. Beginning in model year 2024, the 20 °F UDDS test results will consist of only two UDDS cycles.

(D) Beginning in model year 2024 the *RunningFC* equation used to calculate the City Fuel Economy found on Page 30 in Appendix C of J1634 should be replaced with the following equation when calculating City Fuel Economy:

$$\begin{aligned}
 \text{RunningFC} = & 0.82 \times \left[\frac{0.48}{\text{Bag2 FTP}} + \frac{0.41}{\text{Bag3 FTP}} + \frac{0.11}{\text{US06 City}} \right] \\
 & + 0.18 \times \left[\frac{1}{(20\text{degF UDDS1 Bag2} + 20\text{degF UDDS2 Bag2})} \right. \\
 & \left. + \frac{0.5}{20\text{degF UDDS2 Bag1}} \right] \\
 & + 0.133 \times 1.083 \times \left[\frac{1}{\text{SC03}} - \left(\frac{0.61}{\text{Bag3 FTP}} + \frac{0.39}{\text{Bag2 FTP}} \right) \right]
 \end{aligned}$$

(E) A description of each test group and configuration which will use the 5-cycle adjustment factor, including the battery capacity of the vehicle used to generate the 5-cycle adjustment factor and the battery capacity of all the configurations to which it will be applied.

(v) At the conclusion of the manufacturers testing and after receiving the attestations from the manufacturer regarding the performance of the 20 °F UDDS test processes, the 5-cycle test results, and the summary of vehicles to which the manufacturer proposes applying the 5-cycle adjustment factor, the Administrator will review the submittals and inform the manufacturer in writing if the Administrator concurs with the manufacturer’s proposal. If not, the Administrator will describe the rationale to the manufacturer for not approving their request.

* * * * *

64. Amend § 600.210-12 by revising paragraphs (a) introductory text, (a)(2)(iii), and (d) to read as follows:

§ 600.210-12 Calculation of fuel economy and CO₂ emission values for labeling.

(a) *General labels.* Except as specified in paragraphs (d) and (e) of this section, fuel economy and CO₂ emissions for general labels may be determined by one of two methods. The first is based on vehicle-specific model-type 5-cycle data as determined in § 600.209-12(b). This method is available for all vehicles and is required for vehicles that do not qualify for the second method as described in § 600.115 (other than electric vehicles). The second method, the derived 5-cycle method, determines fuel economy and CO₂ emissions values from the FTP and HFET tests using equations that are derived from vehicle-specific 5-cycle model type data, as determined in paragraph (a)(2) of this section. Manufacturers may voluntarily lower fuel economy (MPG) values and raise CO₂ values if they determine that the label values from any method are not representative of the in-use fuel economy and CO₂ emissions for that model type. ~~MPG values may not be lowered without also making a corresponding change to the CO₂ value for a model type, but only if the manufacturer changes both the MPG values and the CO₂ value and revises any other affected label value accordingly for a model type (including but not limited to the fuel economy 1-10 rating, greenhouse gas 1-10 rating, annual fuel cost, 5-year fuel cost information).~~ Similarly, for any electric vehicles and plug-in hybrid electric vehicles, manufacturers may voluntarily lower the fuel economy (MPGe) and raise the energy consumption (kW-hr/100 mile) values if they determine that the label values are not representative of the in-use fuel economy, energy consumption, and CO₂ emissions for that

model type, but only if the manufacturer changes both the MPGe and the energy consumption value and revises any other affected label value accordingly for a model type. Manufacturers may voluntarily lower the value for electric driving range if they determine that the label values are not representative of the in-use electric driving range.

* * * * *

(2) * * *

(iii) Unless and until superseded by written guidance from the Administrator, the following intercepts and slopes shall be used in the equations in paragraphs (a)(2)(i) and (ii) of this section:

City Intercept = ~~0.003259~~0.004091.

City Slope = ~~-1.1805~~1.1601.

Highway Intercept = ~~-0.001376~~0.003191.

Highway Slope = ~~-1.3466~~1.2945.

* * * * *

(d) *Calculating combined fuel economy, ~~and~~ CO₂ emissions, and driving range.* (1) If the criteria in § 600.115-11(a) are met for a model type, both the city and highway fuel economy and CO₂ emissions values must be determined using the vehicle-specific 5-cycle method. If the criteria in § 600.115-11(b) are met for a model type, the city fuel economy and CO₂ emissions values may be determined using either method, but the highway fuel economy and CO₂ emissions values must be determined using the vehicle-specific 5-cycle method (or modified 5-cycle method as allowed under § 600.114-12(b)(2)).

(2) If the criteria in § 600.115 are not met for a model type, the city and highway fuel economy and CO₂ emission label values must be determined by using the same method, either the derived 5-cycle or vehicle-specific 5-cycle.

(3) Manufacturers may use any one of the following methods ~~for to~~ determining 5-cycle values for fuel economy, ~~and~~ CO₂ emissions, and driving range for electric vehicles:

(i) Generate 5-cycle data as described in paragraph (a)(1) of this section using the procedures of SAE J1634 (incorporated by reference in § 600.011) with amendments and revisions as described in § 600.116-12(a).

(ii) Multiply 2-cycle fuel economy values and driving range by 0.7 and divide 2-cycle CO₂ emission values by 0.7.

(iii) Manufacturers may ask the Administrator to approve adjustment factors for deriving 5-cycle fuel economy results from 2-cycle test data based on operating data from their in-use vehicles. Such data should be collected from multiple vehicles with different drivers over a range of representative driving routes and conditions. The Administrator may approve such an adjustment factor for any of the manufacturer's vehicle models that are properly represented by the collected data.

* * * * *

65. Amend § 600.311-12 by revising paragraphs (j)(2), (j)(4) introductory text, and (j)(4)(i) to read as follows:

§ 600.311-12 Determination of values for fuel economy labels.

* * * * *

(j) * * *

(2) For electric vehicles, determine the vehicle's overall driving range as described in Section 8 of SAE J1634 (incorporated by reference in § 600.011), with amendments and revisions as

described in § 600.116. Determine separate range values for FTP-based city and HFET-based highway driving. Adjust these values to reflect actual in-use driving conditions, then calculate a combined value by arithmetically averaging the two values, weighted 0.55 and 0.45 respectively, and rounding to the nearest whole number.

* * * * *

(4) For plug-in hybrid electric vehicles, determine the adjusted charge-depleting (R_{cda}) battery driving range, the adjusted all electric driving range (if applicable), and overall adjusted driving range as described in SAE J1711 (incorporated by reference in § 600.011), as described in § 600.116, as follows:

(i) Determine the vehicle's Actual Charge-Depleting Range, R_{cda} , and adjust these values to reflect actual in-use driving conditions. Determine separate range values for FTP-based city and HFET-based highway driving, then calculate a combined value by arithmetically averaging the two values, weighted 0.55 and 0.45 respectively, and rounding to the nearest whole number. Precondition the vehicle as needed to minimize engine operation for consuming stored fuel vapors in evaporative canisters; for example, you may purge the evaporative canister or time a refueling event to avoid engine starting related to purging the canister. For vehicles that use combined power from the battery and the engine before the battery is fully discharged, also use this procedure to establish an all electric range by determining the distance the vehicle drives before the engine starts, rounded to the nearest mile. You may represent this as a range of values. We may approve adjustments to these procedures if they are necessary to properly characterize a vehicle's all electric range.

* * * * *

66. Amend § 600.510-12 by revising the entry defining the term “AFE” in paragraph (e) to read as follows:

§ 600.510-12 Calculation of average fuel economy and average carbon-related exhaust emissions.

* * * * *

(e) * * *

AFE = Average combined fuel economy as calculated in paragraph (c)(~~2~~) of this section, rounded to the nearest 0.0001 mpg;

* * * * *

67. Amend § 600.512-12 by adding paragraph (a)(3) and revising paragraph (b) to read as follows:

§ 600.512-12 Model year report.

(a) * * *

(3) Separate reports shall be submitted for passenger automobiles and light trucks (as identified in § 600.510).

(b)(~~4~~) The model year report shall be in writing, signed by the authorized representative of the manufacturer and shall be submitted no later than May 1 following the end of the model year~~90 days after the end of the model year~~. A manufacturer may request an extension for submitting the model year report if that is needed to provide all additional required data as determined in § 600.507. The request must clearly indicate the circumstances necessitating the extension.

~~(2) The Administrator may waive the requirement that the model year report be submitted no later than 90 days after the end of the model year. Based upon a request by the manufacturer, if the Administrator determines that 90 days is insufficient time for the manufacturer to provide all additional data required as determined in §600.507, the Administrator shall establish an alternative date by which the model year report must be submitted.~~

~~(3) Separate reports shall be submitted for passenger automobiles and light trucks (as identified in §600.510).~~

* * * * *

**PART 1030—CONTROL OF GREENHOUSE GAS EMISSIONS FROM ENGINES
INSTALLED ON AIRPLANES**

68. The authority citation for part 1030 continues to read as follows:
Authority: 42 U.S.C. 7401-7671q.

69. Revise §1030.98 to read as follows:

§ 1030.98 Confidential ~~business~~ information.

The provisions of 40 CFR 1068.10 and 1068.11 apply for information you submit under this part~~consider confidential~~.

PART 1033—CONTROL OF EMISSIONS FROM LOCOMOTIVES

70. The authority citation for part 1033 continues to read as follows:
Authority: 42 U.S.C. 7401-7671q.

71. Amend §1033.1 by revising paragraph (e) to read as follows:

§ 1033.1 Applicability.

* * * * *

(e) This part applies for locomotives that were certified as freshly manufactured or remanufactured locomotives under 40 CFR part 92. ~~The provisions of this part apply as specified for locomotives manufactured or remanufactured on or after July 7, 2008. See §1033.102 to determine whether the standards of this part or the standards specified in Appendix I of this part apply for model years 2008 through 2012. For example, for a locomotive that was originally manufactured in 2007 and remanufactured on April 10, 2014, the provisions of this part begin to apply on April 10, 2014.~~

§ 1033.5—[Amended]

72. Amend §1033.5 by removing and reserving paragraph (c).

73. Amend §1033.101 by revising the introductory text to read as follows:

§ 1033.101 Exhaust emission standards.

See ~~§§1033.102 and 1033.150~~ appendix A of this part to determine how ~~the~~ emission standards ~~of this section~~ apply before 2023.

* * * * *

§ 1033.102—[Removed]

74. Remove §1033.102.

75. Amend §1033.115 by revising paragraphs (b) introductory text and (c) to read as follows:

§ 1033.115 Other requirements.

* * * * *

(b) *Adjustable parameters.* Locomotives that have adjustable parameters must meet all the requirements of this part for any adjustment in the approved adjustable range. General provisions for adjustable parameters apply as specified in 40 CFR 1068.50. You must specify in your application for certification the adjustable range of each adjustable parameter on a new locomotive or new locomotive engine to ~~—~~:

* * * * *

(c) *Prohibited controls.* (1) General provisions. You may not design or produce your locomotives with emission control devices, systems, or elements of design that cause or contribute to an unreasonable risk to public health, welfare, or safety while operating. For

example, ~~this would apply if the a~~ locomotive may not emits a noxious or toxic substance it would otherwise not emit that contributes to such an unreasonable risk.

(2) Vanadium sublimation in SCR catalysts. For engines equipped with vanadium-based SCR catalysts, you must design the engine and its emission controls to prevent vanadium sublimation and protect the catalyst from high temperatures. We will evaluate your engine design based on the following information that you must include in your application for certification:

(i) Identify the threshold temperature for vanadium sublimation for your specified SCR catalyst formulation as described in 40 CFR 1065.1113 through 1065.1121.

(ii) Describe how you designed your engine to prevent catalyst inlet temperatures from exceeding the temperature you identify in paragraph (g)(1) of this section, including consideration of engine wear through the useful life. Also describe your design for catalyst protection in case catalyst temperatures exceed the specified temperature. In your description, include how you considered elevated catalyst temperature resulting from sustained high-load engine operation, catalyst exotherms, particulate filter regeneration, and component failure resulting in unburned fuel in the exhaust stream.

* * * * *

76. Amend §1033.120 by revising paragraph (c) to read as follows:

§ 1033.120 Emission-related warranty requirements.

* * * * *

(c) *Components covered.* The emission-related warranty covers all components whose failure would increase a locomotive's emissions of any regulated pollutant. This includes components listed in 40 CFR part 1068, ~~appendix A~~Appendix I, and components from any other system you develop to control emissions. The emission-related warranty covers the components you sell even if another company produces the component. Your emission-related warranty does not need to cover components whose failure would not increase a locomotive's emissions of any regulated pollutant. For remanufactured locomotives, your emission-related warranty is required to cover only those parts that you supply or those parts for which you specify allowable part manufacturers. It does not need to cover used parts that are not replaced during the remanufacture.

* * * * *

77. Amend §1033.205 by revising paragraph (d)(6) to read as follows:

§ 1033.205 Applying for a certificate of conformity.

* * * * *

(d) * * *

(6) A description of injection timing, fuel rate, and all other adjustable operating parameters ~~(including, but not limited to, injection timing and fuel rate)~~, including production tolerances. For any operating parameters that do not qualify as adjustable parameters, include a description supporting your conclusion (see 40 CFR 1068.50(c)). Include the following in your description of each adjustable parameter:including the following:

(i) For mechanically controlled parameters, include Tthe nominal or recommended setting and the associated production tolerances; ~~(ii) T~~the intended adjustable range, and the physically adjustable range; ~~(iii) T~~the limits or stops used to limit adjustable ranges; and (iv)

Production tolerances of the limits or stops used to establish each physically adjustable range. ~~Also include (v) Information showing relating to why the physical limits, or stops used to establish the physically adjustable range of each parameter, or any other means of limiting used to inhibit adjustment, are the most effective means possible of in preventing adjustment of parameters on in-use engines to settings outside your intended physically specified adjustable ranges on in-use engines.~~

(ii) For electronically controlled parameters, describe how your engines are designed to prevent unauthorized adjustments.

* * * * *

78. Amend §1033.245 by adding paragraph (f) to read as follows:

§ 1033.245 Deterioration factors.

* * * * *

(f) You may alternatively determine and verify deterioration factors based on bench-aged aftertreatment as described in 40 CFR 1036.245 and 1036.246, with the following exceptions:

(1) Apply the percentage of useful life from Table 1 of 40 CFR 1036.246 based on hours of operation rather than vehicle mileage.

(2) Perform verification testing as described in subpart F of this part rather than 40 CFR 1036.520. The provisions of 40 CFR 1036.246(d)(2) and (3) do not apply. Perform testing consistent with the original certification to determine whether tested locomotives meet the duty-cycle emission standards in §1033.101.

(3) Apply infrequent regeneration adjustment factors as specified in §1033.535 rather than 40 CFR 1036.522.

79. Revise §1033.525 to read as follows:

§ 1033.525 Smoke opacity testing.

Analyze exhaust opacity test data as follows:

(a) Measure exhaust opacity using the procedures specified in 40 CFR 1065.1125. Perform the opacity test with a continuous digital recording of smokemeter response identified by notch setting over the entire locomotive test cycle specified in §1033.515(c)(4) or §1033.520(e)(4).

Measure smokemeter response in percent opacity to within one percent resolution.

(b) Calibrate the smokemeter as follows:

(1) Calibrate using neutral density filters with approximately 10, 20, and 40 percent opacity. Confirm that the opacity values for each of these reference filters are NIST-traceable within 185 days of testing, or within 370 days of testing if you consistently protect the reference filters from light exposure between tests.

(2) Before each test, remove the smokemeter from the exhaust stream, if applicable, and calibrate as follows:

(i) Zero. Adjust the smokemeter to give a zero response when there is no detectable smoke.

(ii) Linearity. Insert each of the qualified reference filters in the light path perpendicular to the axis of the light beam and adjust the smokemeter to give a result within 1 percentage point of the named value for each reference filter.

(c) Use computer analysis to evaluate percent opacity for each notch setting. Treat the start of the first idle mode as the start of the test. Each mode ends when operator demand changes for the next mode (or for the end of the test). Analyze the opacity trace using the following procedure:

(1) 3 second peak. Identify the highest opacity value over the test and integrate the highest 3 second average including that highest value.

(2) 30 second peak. Divide the test into a series of 30 second segments, advancing each segment in 1 second increments. Determine the opacity value for each segment and identify the highest opacity value from all the 30 second segments.

(3) Steady-state. Calculate the average of second-by-second values between 120 and 180 seconds after the start of each mode. For RMC modes that are less than 180 seconds, calculate the average over the last 60 seconds of the mode. Identify the highest of those steady-state values from the different modes.

(d) Determine values of standardized percent opacity, κ_{std} , by correcting to a reference optical path length of 1 meter for comparing to the standards using the following equation:

$$\kappa_{std} = 100 \cdot \left(1 - \left(1 - \frac{\kappa_{meas}}{100} \right)^{\frac{1}{l_{meas}}} \right)$$

Eq. 1033.525-1

Where:

κ_{meas} = the value of percent opacity from paragraphs (c)(1) through (3) of this section.

l_{meas} = the smokemeter's optical path length in the exhaust plume, expressed to the nearest 0.01 meters.

Example:

$\kappa_m = 14.1 \%$

$l_{meas} = 1.11 \text{ m}$

$$\kappa_{std} = 100 \cdot \left(1 - \left(1 - \frac{14.1}{100} \right)^{\frac{1}{1.11}} \right) = 12.8 \%$$

80. Amend §1033.630 by revising paragraph (b)(1) to read as follows:

§ 1033.630 Staged-assembly and delegated assembly exemptions.

* * * * *

(b) * * *

(1) In cases where an engine has been assembled in its certified configuration, properly labeled, and will not require an aftertreatment device to be attached when installed in the locomotive, no exemption is needed to ship the engine. You do not need an exemption to ship engines without specific components if they are not emission-related components identified in appendix [A4](#) of 40 CFR part 1068.

81. Amend §1033.815 by revising paragraph (f) to read as follows:

§ 1033.815 Maintenance, operation, and repair.

* * * * *

(f) Failure to ~~fully comply with this section is a~~ perform required maintenance is a violation of the tampering prohibition in 40 CFR 1068.101(b)(1). Failure of any person to comply with the recordkeeping requirements of this section is a violation of 40 CFR 1068.101(a)(2).

82. Amend §1033.901 by revising the definition of “Designated Compliance Officer” to read as follows:

§ 1033.901 Definitions.

* * * * *

Designated Compliance Officer means the Director, Diesel Engine Compliance Center, U.S. Environmental Protection Agency, 2000 Traverwood Drive, Ann Arbor, MI 48105; complianceinfo@epa.gov; www.epa.gov/ve-certificationotaq/verify.

* * * * *

83. Redesignate appendix I to part 1033 as appendix A to part 1033 and revise the redesignated appendix A to read as follows:

Appendix ~~A~~I to Part 1033—Original Standards for Tier 0, Tier 1 and Tier 2 Locomotives

(a) ~~The following emission standards applied for new locomotives not yet subject to this part 1033:~~ Locomotives were originally subject to Tier 0, Tier 1, and Tier 2 emission standards described in paragraph (b) of this appendix as follows:

(1) The Tier 0 and Tier 1 standards in paragraph (b) of this appendix applied instead of the Tier 0 and Tier 1 standards of §1033.101 for locomotives manufactured and remanufactured before January 1, 2010. For example, a locomotive that was originally manufactured in 2004 and remanufactured on April 10, 2011 was subject to the original Tier 1 standards specified in paragraph (b) of this appendix and became subject to the Tier 1 standards of §1033.101 when it was remanufactured on April 10, 2011.

(2) The Tier 2 standards in paragraph (b) of this appendix applied instead of the Tier 2 standards of §1033.101 for locomotives manufactured and remanufactured before January 1, 2013.

(b) The following NO_x and PM standards applied before the dates specified in paragraph (a) of this appendix:

Table 1 to Appendix A—Original Locomotive Emission Standards

Type of standard	Year of original manufacture	Tier	Standards (g/bhp-hr)		
			NO _x	PM-primary	PM-alternate ¹
Line-haul	1973-1992	Tier 0	9.5	0.60	0.30
	1993-2004	Tier 1	7.4	0.45	0.22
	2005-2011	Tier 2	5.5	0.20	0.10
Switch	1973-1992	Tier 0	14.0	0.72	0.36
	1993-2004	Tier 1	11.0	0.54	0.27
	2005-2011	Tier 2	8.1	0.24	0.12

¹Locomotives certified to the alternate PM standards are also subject to alternate CO standards of 10.0 for the line-haul cycle and 12.0 for the switch cycle.

| (c) The original Tier 0, Tier 1, and Tier 2 standards for HC and CO emissions and smoke are the same standards identified in §1033.101.

PART 1036--CONTROL OF EMISSIONS FROM NEW AND IN-USE HEAVY-DUTY HIGHWAY ENGINES

84. Revise part 1036 to read as follows:

PART 1036--CONTROL OF EMISSIONS FROM NEW AND IN-USE HEAVY-DUTY HIGHWAY ENGINES

Subpart A—Overview and Applicability

Sec.

1036.1 Applicability.~~Does this part apply for my engines?~~

1036.2 Compliance responsibility.~~Who is responsible for compliance?~~

1036.5 Excluded engines.~~Which engines are excluded from this part's requirements?~~

1036.10 Organization of this part.~~How is this part organized?~~

1036.15 Other applicable regulations.~~Do any other regulation parts apply to me?~~

1036.30 Submission of information.

Subpart B—Emission Standards and Related Requirements

1036.101 ~~0~~ Overview of exhaust emission standards.

1036.104 Criteria pollutant emission standards—NO_x, HC, PM, and CO.

1036.108 Greenhouse gas emission standards—CO₂, CH₄, and N₂O.

1036.110 Diagnostic controls.

1036.111 Inducements related to SCR.

1036.115 Other requirements.

1036.120 Emission-related warranty requirements.

1036.125 Maintenance instructions and allowable maintenance.

1036.130 Installation instructions for vehicle manufacturers.

1036.135 Labeling.

1036.140 Primary intended service class and engine cycle.

1036.150 Interim provisions.

Subpart C—Certifying Engine Families

1036.201 General requirements for obtaining a certificate of conformity.

1036.205 Requirements for an application for certification.~~What must I include in my application?~~

1036.210 Preliminary approval before certification.

1036.225 Amending ~~my~~ applications for certification.

1036.230 Selecting engine families.

1036.235 Testing requirements for certification.

1036.240 Demonstrating compliance with criteria pollutant emission standards.

1036.241 Demonstrating compliance with greenhouse gas emission standards.

1036.245 Deterioration factors for exhaust emission standards.

1036.246 Verifying deterioration factors.

1036.250 Reporting and recordkeeping for certification.

1036.255 ~~What decisions may EPA make regarding my oversight on~~ certificates of conformity?

Subpart D—Testing Production Engines and Hybrid Powertrains

1036.301 Measurements related to GEM inputs in a selective enforcement audit.

Subpart E—In-use Testing

[1036.401 Testing requirements for in-use engines.](#)~~In-use testing.~~
[1036.405 Overview of the manufacturer-run field-testing program.](#)
[1036.410 Selecting and screening vehicles and engines for testing.](#)
[1036.415 Preparing and testing engines.](#)
[1036.420 Pass criteria for individual engines.](#)
[1036.425 Pass criteria for engine families.](#)
[1036.430 Reporting requirements.](#)
[1036.435 Recordkeeping requirements.](#)
[1036.440 Warranty obligations related to in-use testing.](#)

Subpart F—Test Procedures

[1036.501 ~~How do I run a valid emission test?~~General testing provisions.](#)
1036.503 Engine data and information ~~for~~ [to support](#) vehicle certification.
1036.505 Supplemental [Emission Test](#)~~emission test~~.
1036.510 [Federal Test Procedure](#)~~Transient testing~~.
[1036.512 Low Load Cycle.](#)
[1036.514 Clean Idle test.](#)
[1036.515 Test procedures for off-cycle testing.](#)
[1036.520 Test procedures to verify deterioration factors.](#)
[1036.522 Infrequently regenerating aftertreatment devices.](#)~~1036.525 Hybrid engines.~~
1036.527 Powertrain system rated power determination.
1036.530 Calculating greenhouse gas emission rates.
1036.535 Determining steady-state engine fuel maps and fuel consumption at idle.
1036.540 Determining cycle-average engine fuel maps.
1036.543 Carbon balance error verification.

Subpart G—Special Compliance Provisions

1036.601 [Overview of compliance provisions.](#)~~What compliance provisions apply?~~
1036.605 [Alternate emission standards](#)~~GHG exemption~~ for engines used in specialty vehicles.
1036.610 Off-cycle technology credits and adjustments for reducing greenhouse gas emissions.
1036.615 Engines with Rankine cycle waste heat recovery and hybrid powertrains.
1036.620 Alternate CO₂ standards based on model year 2011 compression-ignition engines.
1036.625 In-use compliance with [CO₂](#) family emission limits (FELs).
1036.630 Certification of engine [GHG greenhouse gas](#) emissions for powertrain testing.
[1036.635—\[Reserved\]](#)
[1036.655 Special provisions for diesel-fueled engines sold in American Samoa or the Commonwealth of the Northern Mariana Islands.](#)

Subpart H—Averaging, Banking, and Trading for Certification

1036.701 General provisions.
1036.705 Generating and calculating emission credits.
1036.710 Averaging.
1036.715 Banking.
1036.720 Trading.
1036.725 [Required information for certification.](#)~~What must I include in my application for certification?~~
1036.730 ABT reports.
1036.735 Recordkeeping.
1036.740 Restrictions for using emission credits.

1036.741 Using emission credits from electric vehicles and hydrogen fuel-cell vehicles.

1036.745 End-of-year CO₂ credit deficits.

1036.750 Consequences for noncompliance. ~~What can happen if I do not comply with the provisions of this subpart?~~

1036.755 Information provided to the Department of Transportation.

Subpart I—Definitions and Other Reference Information

1036.801 Definitions.

1036.805 Symbols, abbreviations, and acronyms.

1036.810 Incorporation by reference.

1036.815 Confidential information.

1036.820 Requesting a hearing.

1036.825 Reporting and recordkeeping requirements.

Appendix A ~~to~~ of Part 1036—Summary of Previous Emission Standards

Appendix B ~~to~~ of Part 1036—Transient Duty Cycles

Appendix C ~~to~~ of Part 1036 — Default Engine Fuel Maps for § 1036.540

Authority: 42 U.S.C. 7401 - 7671q.

Subpart A—Overview and Applicability

§ 1036.1 Applicability. ~~Does this part apply for my engines?~~

(a) Except as specified in § 1036.5, the provisions of this part apply for engines that will be installed in heavy-duty vehicles (including glider vehicles) ~~above 14,000 pounds GVWR for propulsion. These provisions also apply for engines that will be installed in incomplete heavy-duty vehicles at or below 14,000 pounds GVWR unless the engine is installed in a vehicle that is covered by a certificate of conformity under 40 CFR part 86, subpart S.~~

(b) Heavy-duty engines produced before model year 2027 are subject to greenhouse gas emission standards and related provisions under this part as specified in §1036.108; these engines are subject ~~This part does not apply with respect~~ to exhaust emission standards for HC, CO, NO_x, ~~and~~ PM and related provisions under 40 CFR part 86, subpart A, instead of this part, except as follows:

(1) The provisions of §§ 1036.115, 1036.501(f), and 1036.601 apply.

(2) 40 CFR parts 85 and ~~or~~ 86 may specify that certain provisions apply.

(3) ~~The provisions of § 1036.501(h)(1) apply.~~

This part describes how several individual provisions are optional or mandatory before model year 2027. For example, §1036.150(a) describes how you may generate emission credits by meeting the standards of this part before model year 2027.

(c) The provisions of this part also apply for fuel conversions of all engines described in paragraph (a) of this section as described in 40 CFR 85.502.

(d) Gas turbine heavy-duty engines and other heavy-duty engines not meeting the definition *compression-ignition* or *spark-ignition* are deemed to be compression-ignition engines for purposes of this part.

§ 1036.2 Compliance responsibility. ~~Who is responsible for compliance?~~

The regulations in this part ~~1036~~ contain provisions that affect both engine manufacturers and others. However, the requirements of this part are generally addressed to the engine manufacturer(s). The term "you" generally means the engine manufacturer(s), especially for

issues related to certification. Additional requirements and prohibitions apply to other persons as specified in subpart G of this part and 40 CFR part 1068.

§ 1036.5 Excluded engines. ~~Which engines are excluded from this part's requirements?~~

- (a) The provisions of this part do not apply to engines used in medium-duty passenger vehicles or other heavy-duty vehicles that are subject to regulation under 40 CFR part 86, subpart S, except as specified in 40 CFR part 86, subpart S, and § 1036.150(j). For example, this exclusion applies for engines used in vehicles certified to the standards of 40 CFR 86.1818 and 86.1819.
- (b) An engine installed in a heavy-duty vehicle that is not used to propel the vehicle is not a heavy-duty engine. The provisions of this part therefore do not apply to these engines. Note that engines used to indirectly propel the vehicle (such as electrical generator engines that provide power to batteries for propulsion) are subject to this part. See 40 CFR part 1039, 1048, or 1054 for other requirements that apply for these auxiliary engines. See 40 CFR part 1037 for requirements that may apply for vehicles using these engines, such as the evaporative emission requirements of 40 CFR 1037.103.
- (c) The provisions of this part do not apply to aircraft or aircraft engines. Standards apply separately to certain aircraft engines, as described in 40 CFR part 87.
- (d) The provisions of this part do not apply to engines that are not internal combustion engines, except as specified in §1036.741. For example, the provisions of this part generally do not apply to fuel cells. Note that gas turbine engines are internal combustion engines.
- (e) The provisions of this part do not apply for model year 2013 and earlier heavy-duty engines unless they were:
- (1) Voluntarily certified to this part.
 - (2) Installed in a glider vehicle subject to 40 CFR part 1037.

§ 1036.10 Organization of this part. ~~How is this part organized?~~

This part ~~1036~~ is divided into the following subparts:

- (a) Subpart A of this part defines the applicability of this part ~~1036~~ and gives an overview of regulatory requirements.
- (b) Subpart B of this part describes the emission standards and other requirements that must be met to certify engines under this part. Note that § 1036.150 describes certain interim requirements and compliance provisions that apply only for a limited time.
- (c) Subpart C of this part describes how to apply for a certificate of conformity.
- (d) Subpart D of this part addresses testing of production engines.
- (e) Subpart E of this part describes provisions for testing in-use engines.
- (f) Subpart F of this part describes how to test your engines (including references to other parts of the Code of Federal Regulations).
- (g) Subpart G of this part describes requirements, prohibitions, and other provisions that apply to engine manufacturers, vehicle manufacturers, owners, operators, rebuilders, and all others.
- (h) Subpart H of this part describes how you may generate and use emission credits to certify your engines.
- (i) Subpart I of this part contains definitions and other reference information.

§ 1036.15 Other applicable regulations. ~~Do any other regulation parts apply to me?~~

- (a) Parts 85 and 86 of this chapter describes additional provisions requirements that apply to engines that are subject to this part ~~1036~~. See § 1036.601. ~~This part extensively references~~

~~portions of 40 CFR part 86. For example, the regulations of part 86 specify emission standards and certification procedures related to criteria pollutants.~~

(b) Part 1037 of this chapter describes requirements for controlling evaporative emissions and greenhouse gas emissions from heavy-duty vehicles, whether or not they use engines certified under this part. ~~It also includes standards and requirements that apply instead of the standards and requirements of this part in some cases.~~

(c) Part 1065 of this chapter describes procedures and equipment specifications for testing engines to measure exhaust emissions. Subpart F of this part ~~1036~~ describes how to apply the provisions of part 1065 of this chapter to determine whether engines meet the exhaust emission standards in this part.

(d) ~~Certain provisions of p~~The requirements and prohibitions of part 1068 of this chapter apply as specified in § 1036.601 to everyone, including anyone who manufactures, imports, installs, owns, operates, or rebuilds any of the engines subject to this part ~~1036~~, or vehicles containing these engines. ~~Part 1068 of this chapter describes general provisions that apply broadly, but do not necessarily apply for all engines or all persons.~~ See § 1036.601 to determine how to apply the part 1068 regulations for heavy-duty engines. The issues addressed by these provisions include these seven areas:

- (1) Prohibited acts and penalties for engine manufacturers, vehicle manufacturers, and others.
- (2) Rebuilding and other aftermarket changes.
- (3) Exclusions and exemptions for certain engines.
- (4) Importing engines.
- (5) Selective enforcement audits of your production.
- (6) Recall.
- (7) Procedures for hearings.

(e) Other parts of this chapter apply if referenced in this part.

§ 1036.30 Submission of information.

Unless we specify otherwise, send all reports and requests for approval to the Designated Compliance Officer (see § 1036.801). See § 1036.825 for additional reporting and recordkeeping provisions.

Subpart B—Emission Standards and Related Requirements

§ 1036.1010 Overview of exhaust emission standards.

~~Engines used in vehicles certified to the applicable chassis standards for greenhouse gases described in 40 CFR 86.1819 are not subject to the standards specified in this part. All other engines subject to this part must meet the greenhouse gas standards in § 1036.108 in addition to the criteria pollutant standards of 40 CFR part 86.~~ (a) You must show that engines meet the following exhaust emission standards:

- (1) Criteria pollutant standards for NO_x, HC, PM, and CO apply as described in §1036.104.
- (2) Greenhouse gas (GHG) standards for CO₂, CH₄, and N₂O apply as described in §1036.108.

(b) You may optionally demonstrate compliance with the emission standards of this part by testing hybrid engines and hybrid powertrains, rather than testing the engine alone. Except as specified, provisions of this part that reference engines apply equally to hybrid engines and hybrid powertrains.

§ 1036.104 Criteria pollutant emission standards—NO_x, HC, PM, and CO.

This section describes the applicable NO_x, HC, CO, and PM standards for model years 2027 and later. These standards apply equally for all primary intended service classes unless otherwise noted.

(a) Emission standards. Exhaust emissions may not exceed the standards in this section for the specified duty cycle, as follows:

(1) Measure emissions over the specified duty cycles using the test procedures described in subpart F of this part.

(2) The following emission standards apply over the FTP and SET duty cycles:

Table 1 of §1036.104—FTP and SET Emission Standards

<u>Model Year</u>	<u>NO_x mg/hp·hr</u>	<u>HC mg/hp·hr</u>	<u>PM mg/hp·hr</u>	<u>CO g/hp·hr</u>
<u>2027-2030</u>	<u>35</u>	<u>60</u>	<u>5</u>	<u>6.0</u>
<u>2031 and later</u>	<u>20^a</u>	<u>40</u>	<u>5</u>	<u>6.0</u>

^aThe NO_x standard identified for Heavy HDE applies for an intermediate useful life of 435,000 miles, 10 years, or 22,000 hours, whichever comes first. A standard of 40 mg/hp·hr applies for the rest of the useful life.

(3) The following emission standards apply for compression-ignition engines over the Low Load Cycle:

Table 2 of §1036.104—Low Load Cycle Emission Standards

<u>Model Year</u>	<u>NO_x mg/hp·hr</u>	<u>HC mg/hp·hr</u>	<u>PM mg/hp·hr</u>	<u>CO g/hp·hr</u>
<u>2027-2030</u>	<u>90</u>	<u>140</u>	<u>5</u>	<u>6.0</u>
<u>2031 and later</u>	<u>50^a</u>	<u>60</u>	<u>5</u>	<u>6.0</u>

^aThe NO_x standard identified for Heavy HDE applies for an intermediate useful life of 435,000 miles, 10 years, or 22,000 hours, whichever comes first. A standard of 100 mg/hp·hr applies for the rest of the useful life.

(4) Off-cycle emission standards apply for compression-ignition engines using the procedures specified in §1036.515. For the idle bin, the NO_x off-cycle emission standard is 10.0 g/hr starting in model years 2027 through 2030 and 7.5 g/hr starting in model year 2031. Additional off-cycle emission standards apply as described in the following table:

Table 3 of §1036.104—Off-Cycle Emission Standards for Compression-Ignition Engines

<u>Model Year</u>	<u>Bin</u>	<u>NO_x mg/hp·hr</u>	<u>HC mg/hp·hr</u>	<u>PM mg/hp·hr</u>	<u>CO g/hp·hr</u>
<u>2027-2030</u>	<u>Low load</u>	<u>180</u>	<u>280</u>	<u>10</u>	<u>12.0</u>
	<u>Medium/high load</u>	<u>70</u>	<u>120</u>	<u>10</u>	<u>12.0</u>
<u>2031 and later</u>	<u>Low load</u>	<u>75^a</u>	<u>90</u>	<u>8</u>	<u>9.0</u>
	<u>Medium/high load</u>	<u>30^a</u>	<u>60</u>	<u>8</u>	<u>9.0</u>

^aThe low load and medium/high load NO_x standards identified for Heavy HDE apply for an intermediate useful life of 435,000 miles, 10 years, or 22,000 hours, whichever comes first. A low load bin standard of 150 mg/hp·hr and a medium/high load bin standard of 60 mg/hp·hr apply for the rest of the useful life.

(b) Clean Idle. You may optionally certify compression-ignition engines to the Clean Idle NO_x emission standard using the Clean Idle test specified in § 1036.514. The optional Clean Idle NO_x emission standard is 30.0 g/h before model year 2024, 10.0 g/h for model years 2024 through 2026, and 5.0 g/hr for model year 2027 and later. The mass emission rate of HC, CO, and PM in g/hr during the Clean Idle test may not exceed the emission results from the idle modes of the SET duty cycle as described in § 1036.505(h) or the idle segments of the FTP duty cycle as described in § 1036.510(g). The standard applies separately to each mode of the Clean Idle test. If you certify an engine family to the Clean Idle standards, it is subject to all these voluntary standards as if they were mandatory.

(c) Averaging, banking, and trading. You may generate or use emission credits under the averaging, banking, and trading (ABT) program described in subpart H of this part for demonstrating compliance with NO_x emission standards in paragraph (a) of this section. You must meet the PM, HC, and CO emission standards in §1036.104(a) without generating or using emission credits.

(1) To generate or use emission credits, you must specify a family emission limit for each engine family. Declare the family emission limit corresponding to full useful life for engine operation over the FTP duty cycle, FEL_{FTP} , expressed to the same number of decimal places as the emission standard. Use FEL_{FTP} to calculate emission credits in subpart H of this part.

(2) The following NO_x FEL caps are the maximum values you may specify for FEL_{FTP} :

(i) 150 mg/hp·hr for model year 2027 through 2030 Spark-ignition HDE, Light HDE, Medium HDE, and Heavy HDE.

(ii) 50 mg/hp·hr for model year 2031 and later Spark-ignition HDE, Light HDE, and Medium HDE.

(iii) 70 mg/hp·hr for model year 2031 and later Heavy HDE.

(3) Calculate the NO_x family emission limit, $FEL_{[cycle]NO_x}$, that applies for each duty-cycle or off-cycle standard using the following equation, noting that you must also use this approach to determine the FEL for each cycle that applies for Heavy HDE at intermediate useful life:

$$FEL_{[cycle]NO_x} = Std_{[cycle]NO_x} \cdot \frac{FEL_{FTPNO_x}}{Std_{FTPNO_x}}$$

Eq. 1036.104-1

Where:

$Std_{[cycle]NO_x}$ = the NO_x emission standard that applies for the applicable cycle under paragraph (a) of this section for engines not participating in the ABT program.

FEL_{FTPNOx} = the engine family’s declared FEL for NO_x over the FTP duty cycle from paragraph (c)(1) of this section.

Std_{FTPNOx} = the NO_x emission standard that applies for the FTP duty cycle under paragraph (a) of this section for engines not participating in the ABT program.

Example for model year 2029 Medium HDE for the SET:

$Std_{SETNOx} = 35 \text{ mg/hp}\cdot\text{hr}$

$FEL_{FTP} = 121 \text{ mg/hp}\cdot\text{hr}$

$Std_{FTPNOx} = 35 \text{ mg/hp}\cdot\text{hr}$

$$FEL_{SETNOx} = 35 \cdot \frac{121}{35} = 121 \text{ mg/hp}\cdot\text{hr}$$

(4) The family emission limits in this paragraph (c) serve as the emission standards for compliance testing instead of the standards specified in this section.

(d) *Fuel types.* The exhaust emission standards in this section apply for engines using the fuel type on which the engines in the engine family are designed to operate. You must meet the numerical emission standards for HC in this section based on the following types of hydrocarbon emissions for engines powered by the following fuels:

(1) Alcohol-fueled engines: NMHCE emissions.

(2) Gaseous-fueled engines: NMNEHC emissions.

(3) Other engines: NMHC emissions.

(e) *Useful life.* The exhaust emission standards of this section apply for the useful life, expressed in vehicle miles, or hours of engine operation, or years in service, whichever comes first, as follows:

Table 4 of §1036.104—Useful life by Primary Intended Service Class

<u>Primary Intended Service Class</u>	<u>Model year 2027 through 2030</u>		<u>Model year 2031 and later</u>	
	<u>Miles</u>	<u>Years</u>	<u>Miles</u>	<u>Years</u>
<u>Spark-ignition HDE</u>	<u>155,000</u>	<u>12</u>	<u>200,000</u>	<u>15</u>
<u>Light HDE</u>	<u>190,000</u>	<u>12</u>	<u>270,000</u>	<u>15</u>
<u>Medium HDE</u>	<u>270,000</u>	<u>11</u>	<u>350,000</u>	<u>12</u>
<u>Heavy HDE^a</u>	<u>600,000</u>	<u>11</u>	<u>800,000^b</u>	<u>12</u>

^aUseful life for Heavy HDE is also expressed as 32,000 operating hours for model year 2027 through 2030, and 40,000 operating hours for model year 2031 and later. For an individual engine, the useful life is no shorter than 10 years or 100,000 miles, whichever occurs first, regardless of operating hours.

^bAdditional standards apply for Heavy HDE during an intermediate useful life of 435,000 miles, 10 years, or 22,000 hours, whichever comes first.

(f) *Applicability for testing.* The emission standards in this subpart apply to all testing, including certification, selective enforcement audits, and in-use testing. For selective enforcement audits, we may require you to perform the appropriate duty-cycle testing as specified in §§1036.505, 1036.510 and 1036.512. The off-cycle standards in this section apply for duty-cycle testing you perform for a selective enforcement audit. We may direct you to do additional testing to show that your engines meet the off-cycle standards.

§ 1036.108 Greenhouse gas emission standards—CO₂, CH₄, and N₂O.

This section contains standards and other regulations applicable to the emission of the air pollutant defined as the aggregate group of six greenhouse gases: carbon dioxide, nitrous oxide, methane, hydrofluorocarbons, perfluorocarbons, and sulfur hexafluoride. This section describes the applicable CO₂, N₂O, and CH₄ standards for engines. ~~These standards do not apply for engines used in vehicles subject to (or voluntarily certified to) the CO₂, N₂O, and CH₄ standards for vehicles specified in 40 CFR 86.1819.~~

(a) *Emission standards.* ~~The e~~**E**mission standards ~~in this paragraph (a)~~ apply for engines and optionally powertrains measured using the test procedures specified in subpart F of this part as follows:

(1) CO₂ emission standards in this paragraph (a)(1) apply based on testing as specified in subpart F of this part. The applicable test cycle for measuring CO₂ emissions differs depending on the engine family’s primary intended service class and the extent to which the engines will be (or were designed to be) used in tractors. For ~~M~~**medium HDE** and ~~H~~**heavy heavy-duty enginesHDE** certified as tractor engines, measure CO₂ emissions using the ~~SET~~ steady-state duty cycle specified in § 1036.50~~51~~ ~~(referred to as the Supplemental Emission Test, or SET, even though emission sampling involves measurements from discrete modes).~~ This testing with the SET duty cycle is intended for engines designed to be used primarily in tractors and other line-haul applications. Note that the use of some SET-certified tractor engines in vocational applications does not affect your certification obligation under this paragraph (a)(1); see other provisions of this part and 40 CFR part 1037 for limits on using engines certified to only one cycle. For ~~M~~**medium HDE** and ~~H~~**heavy heavy-duty enginesHDE** certified as both tractor and vocational engines, measure CO₂ emissions using the ~~steady-state~~**SET** -duty cycle specified in § 1036.50~~51~~**505 and the FTP transient duty cycle specified in § 1036.510.** Testing with both SET and FTP duty cycles is intended for engines that are designed for use in both tractor and vocational applications. For all other engines (including ~~Spark-ignition HDE~~), measure CO₂ emissions using the ~~appropriate~~**FTP** transient duty cycle specified in § 1036.5~~10~~**104.**

(i) The CO₂ standard is 627 g/hp·hr for all spark-ignition engines for model years 2016 through 2020. This standard continues to apply in later model years for all spark-ignition engines that are not ~~H~~**heavy HDEheavy-duty engines.**

(ii) The following CO₂ standards apply for compression-ignition engines (in g/hp·hr):

Table 1 of §1036.108—Compression-Ignition Engine Standards for ~~Model Years~~**MY** 2014 – 2020

Model Years	Light Heavy-Duty	Medium Heavy-Duty-Vocational	Heavy Heavy-Duty-Vocational	Medium Heavy-Duty-Tractor	Heavy Heavy-Duty-Tractor
2014-2016	600	600	567	502	475
2017-2020	576	576	555	487	460

(iii) The following CO₂ standards apply for compression-ignition engines and all ~~H~~**heavy HDEheavy-duty engines** (in g/hp·hr):

Table 2 of §1036.108—Compression-Ignition Engine Standards for ~~Model Years~~MY 2021 and Later

Model Years	Light Heavy-Duty	Medium Heavy-Duty-Vocational	Heavy Heavy-Duty-Vocational	Medium Heavy-Duty-Tractor	Heavy Heavy-Duty-Tractor
2021-2023	563	545	513	473	447
2024-2026	555	538	506	461	436
2027 and later	552	535	503	457	432

(iv) You may certify spark-ignition engines to the compression-ignition standards for the appropriate model year under this paragraph (a). If you do this, those engines are treated as compression-ignition engines for all the provisions of this part.

(2) The CH₄ emission standard is 0.10 g/hp·hr when measured over the applicable transient duty cycle specified in ~~§ 1036.510~~40 CFR part 86, subpart N. This standard begins in model year 2014 for compression-ignition engines and in model year 2016 for spark-ignition engines. Note that this standard applies for all fuel types just like the other standards of this section.

(3) The N₂O emission standard is 0.10 g/hp·hr when measured over the transient duty cycle specified in ~~§ 1036.510~~40 CFR part 86, subpart N. This standard begins in model year 2014 for compression-ignition engines and in model year 2016 for spark-ignition engines.

(b) *Family Certification Levels.* You must specify a CO₂ Family Certification Level (FCL) for each engine family. The FCL may not be less than the certified emission level for the engine family. The CO₂ Family Emission Limit (FEL) for the engine family is equal to the FCL multiplied by 1.03.

(c) *Averaging, banking, and trading.* You may generate or use emission credits under the averaging, banking, and trading (ABT) program described in subpart H of this part for demonstrating compliance with CO₂ emission standards. Credits (positive and negative) are calculated from the difference between the FCL and the applicable emission standard. As described in § 1036.705, you may use CO₂ credits to certify your engine families to FELs for N₂O and/or CH₄, instead of the N₂O/CH₄ standards of this section that otherwise apply. Except as specified in §§ 1036.150 and 1036.705, you may not generate or use credits for N₂O or CH₄ emissions.

(d) *Useful life.* The exhaust emission standards of this section apply for the ~~full~~ useful life, expressed ~~as vehicle miles, or hours of engine operation, or years in service, whichever comes first, as follows:~~as vehicle miles, or hours of engine operation, or years in service, whichever comes first. ~~The useful life values applicable to the criteria pollutant standards of 40 CFR part 86 apply for the standards of this section, except that the spark ignition standards and the standards for model year 2021 and later light heavy duty engines apply over a useful life of 15 years or 150,000 miles, whichever comes first.~~

Table 3 of §1036.108—Useful life by Primary Intended Service Class for Model Year 2021 and Later

<u>Primary Intended Service Class</u>	<u>Miles</u>	<u>Years</u>
<u>Spark-ignition HDE</u>	<u>150,000</u>	<u>15</u>
<u>Light HDE</u>	<u>150,000</u>	<u>15</u>
<u>Medium HDE</u>	<u>185,000</u>	<u>10</u>
<u>Heavy HDE^a</u>	<u>435,000</u>	<u>10</u>

^aUseful life for Heavy HDE is also expressed as 22,000 operating hours. For an individual engine, the useful life is no shorter than 10 years or 100,000 miles, whichever occurs first, regardless of operating hours.

(e) *Applicability for testing.* The emission standards in this subpart apply as specified in this paragraph (e) to all duty-cycle testing (according to the applicable test cycles) of testable configurations, including certification, selective enforcement audits, and in-use testing. The CO₂ FCLs serve as the CO₂ emission standards for the engine family with respect to certification and confirmatory testing instead of the standards specified in paragraph (a)(1) of this section. The FELs serve as the emission standards for the engine family with respect to all other duty-cycle testing. See §§ 1036.235 and 1036.241 to determine which engine configurations within the engine family are subject to testing. Note that engine fuel maps and powertrain test results also serve as standards as described in § 1036.535, § 1036.540, § 1036.630 and 40 CFR 1037.550.

~~(f) *Multi-fuel engines.* For dual-fuel, multi-fuel, and flexible-fuel engines, perform exhaust testing on each fuel type (for example, gasoline and E85).~~

~~(1) This paragraph (f)(1) applies where you demonstrate the relative amount of each fuel type that your engines consume in actual use. Based on your demonstration, we will specify a weighting factor and allow you to submit the weighted average of your emission results. For example, if you certify an E85 flexible-fuel engine and we determine the engine will produce one-half of its work from E85 and one-half of its work from gasoline, you may apply a 50 percent weighting factor to each of your E85 and gasoline emission results.~~

~~(2) If you certify your engine family to N₂O and/or CH₄ FELs the FELs apply for testing on all fuel types for which your engine is designed, to the same extent as criteria emission standards apply.~~

§ 1036.110 Diagnostic controls.

Onboard diagnostic (OBD) systems must generally detect malfunctions in the emission control system, store trouble codes corresponding to detected malfunctions, and alert operators appropriately. Starting in model year 2027, new engines must have OBD systems as described in this section. You may optionally comply with any or all of the requirements of this section instead of 40 CFR 86.010-18 in earlier model years.

(a) Chassis-based OBD requirements apply instead of the requirements of this section for certain engines as follows:

(1) Heavy-duty engines intended to be installed in heavy duty vehicles at or below 14,000 pounds GVWR must meet the requirements in 40 CFR 86.1806.

(2) Heavy-duty spark-ignition engines intended to be installed in heavy-duty vehicles above 14,000 pounds GVWR may meet the requirements in 40 CFR 86.1806 if the engines share essential design characteristics with engines that the engine manufacturer also installs in vehicles certified under 40 CFR part 86, subpart S.

(b) Engines must comply with the 2019 heavy-duty OBD requirements adopted for California as described in this paragraph (b). California's 2019 heavy-duty OBD requirements are part of 13 CCR 1968.2, 1968.5, 1971.1, and 1971.5 (incorporated by reference in §1036.810). We may approve your request to certify an OBD system meeting alternative specifications if you demonstrate that it meets the intent of this section. For example, we may approve your request for a system that meets a later version of California's OBD requirements if you demonstrate that it meets the intent of this section. To demonstrate that your engine meets the intent of this section, the OBD system meeting alternative specifications must address all the provisions described in paragraph (b) and (c) of this section. The following clarifications and exceptions apply for engines certified under this part:

(1) We may approve a small manufacturer's request to delay complying with the requirements of this section for up to three model years if that manufacturer has not certified those engines or other comparable engines in California for those model years.

(2) For engines not certified in California, references to vehicles meeting certain California Air Resources Board emission standards are understood to refer to the corresponding EPA emission standards for a given family, where applicable. Use good engineering judgment to correlate the specified standards with the EPA standards that apply under this part. You must describe in your application for certification how you will perform testing to demonstrate compliance with OBD requirements to represent all your engine families over five or fewer model years.

(3) Engines must comply with OBD requirements throughout the useful life as specified in § 1036.104.

(4) The purpose and applicability statements in 13 CCR 1971.1(a) and (b) do not apply.

(5) Compression-ignition engines are subject to a NO_x threshold of 0.40 g/hp-hr and a PM threshold of 0.03 g/hp-hr for operation on the FTP and SET duty cycles. Spark-ignition engines are subject to the following thresholds:

(i) 0.015 g/hp-hr for PM emissions.

(ii) 0.30 g/hp-hr for monitors detecting a malfunction before NO_x emissions exceed 1.5 times the applicable standard.

(iii) 0.35 g/hp-hr for monitors detecting a malfunction before NO_x emissions exceed 1.75 times the applicable standard.

(iv) 0.60 g/hp-hr for monitors detecting a malfunction before NO_x emissions exceed 3.0 times the applicable standard.

(6) The testing and reporting requirements in 13 CCR 1971.1(i)(2.3) and (2.4) do not apply.

(7) The deficiency provisions described in paragraph (d) of this section apply instead of 13 CCR 1971.1 (k).

(8) Capture the following elements as freeze frame data:

(i) Data parameters specified in 13 CCR 1971.1(h)(4.2) and (4.3).

(ii) System health monitor parameters specified in paragraph (c)(3) of this section.

(9) Design compression-ignition engines to make the following additional parameters available for reading with a generic scan tool, if so equipped:

(i) Engine and vehicle parameters. Status of parking brake, neutral switch, brake switch, and clutch switch, wastegate control solenoid output, wastegate position (commanded and actual), speed and output shaft torque consistent with §1036.115(d).

(ii) Diesel oxidation catalyst parameters. Include inlet and outlet pressure and temperature for the diesel oxidation catalyst.

(iii) Particulate filter parameters. Include filter soot load and ash load for all installed particulate filters.

(iv) EGR parameters. Include differential pressure for exhaust gas recirculation.

(v) SCR parameters. Include DEF quality-related signals, output of aftertreatment doser system (pump and injectors), DEF coolant control valve position (commanded and actual), DEF tank temperature, DEF system pressure, DEF pump commanded percentage, DEF doser control status, DEF line heater control outputs.

(vi) Include any additional parameters if they are related to engine derating or other inducements under §1036.111 or §1036.125.

(10) Design spark-ignition engines to make the following additional parameters available for reading with a generic scan tool, if applicable:

(i) Air/fuel enrichment parameters. Percent of time in enrichment, both for each trip (key-on to key-off) and as a cumulative lifetime value. Track values separately for enrichment based on throttle, engine protection, and catalyst protection.

(ii) Component temperature parameters. Include component temperatures (measured and modeled, if applicable) used for catalyst protection.

(11) If you have an approved Executive order from the California Air Resources Board for a given engine family, we may rely on that Executive order to evaluate whether you meet federal OBD requirements for that same engine family or an equivalent engine family. Engine families are equivalent if they are identical in all aspects material to emission characteristics. EPA would count two equivalent engines families as one for the purposes of determining OBD demonstration testing requirements. Send us the following information:

(i) You must submit additional information as needed to demonstrate that you meet the requirements of this section that are not covered by the California Executive order.

(ii) Send us results from any testing you performed for certifying engine families (including equivalent engine families) with the California Air Resources Board, including the results of any testing performed under 13 CCR 1971.1(i)(2.3) and (2.4), 13 CCR 1971.1(l), and 13 CCR 1971.5(b).

(iii) We may require that you send us additional information if we need it to evaluate whether you meet the requirements of this section. This may involve sending us copies of documents you send to the California Air Resources Board.

(c) The following additional provisions apply:

(1) Design the diagnostic system to display the following information in the cab:

(i) The health monitoring information specified in paragraph (b)(8) of this section.

(ii) The information related to inducements as specified in §1036.111(f).

(2) Diagnostic testing to measure the effectiveness of DEF dosing must be made available for use with either a generic scan tool or an equivalent alternative method (such as an option commanded through a vehicle system menu).

(3) The following provisions related to system health monitors apply:

(i) Provide the following information related to particulate filters:

(A) An indicator of general system wear, such as the total number of regeneration events that have taken place since installing the current particulate filter.

(B) Indicator of historical and current active and passive regeneration frequency.

(C) The estimated mileage until the particulate filter needs cleaning to remove accumulated ash.

- (D) Information describing any disabled regeneration if this is accompanied by engine derating. Also include the reason for disabling.
- (ii) Provide the following information related to SCR:
- (A) An indicator of historical and current DEF consumption.
- (B) Information describing any disabled DEF dosing if this is accompanied by engine derating. Also include the reason for disabling.
- (C) Information describing any detected flow obstruction in DEF lines or dosing valve in anticipation of triggering an inducement under §1036.111(b)(2).
- (iii) Provide an indication of EGR valve health, such as by comparing commanded and actual EGR position.
- (iv) Provide an indicator of EGR cooler performance, such as by displaying parameters described in 13 CCR 1971.1(e)(3.2.5).
- (v) Provide current data under paragraphs (c)(3)(i) and (ii) of this section based on a default method of updating or resetting collected data. For example, the current data may include information from the Active 100-Hour Array or Stored 100-Hour Array. The system must allow the operator to perform a manual reset to start collecting new data on demand.
- (d) You may ask us to accept as compliant an engine that does not fully meet specific requirements under this section. The following provisions apply regarding OBD system deficiencies:
- (1) We will not approve a deficiency for gasoline-fueled or diesel-fueled engines if it involves the complete lack of a major diagnostic monitor, such as monitors related to exhaust aftertreatment devices, oxygen sensors, air-fuel ratio sensors, NO_x sensors, engine misfire, evaporative leaks, and diesel EGR (if applicable). We may approve such deficiencies for engines using other fuels if you demonstrate that the alternative fuel causes these monitors to be unreliable.
- (2) We will approve a deficiency only if you show us that full compliance is infeasible or unreasonable considering any relevant factors, such as the technical feasibility of a given monitor, or the lead time and production cycles of vehicle designs and programmed computing upgrades.
- (3) Our approval for a given deficiency applies only for a single model year, though you may continue to ask us to extend a deficiency approval in renewable one-year increments. We may approve an extension if you demonstrate an acceptable level of progress toward compliance and you show that the necessary hardware or software modifications would pose an unreasonable burden. We will approve a deficiency for more than two years only if you further demonstrate that you need the additional lead time to make substantial changes to engine hardware.
- (4) We will not approve deficiencies retroactively.

§ 1036.111 Inducements related to SCR.

Engines using SCR to control emissions depend on a constant supply of diesel exhaust fluid (DEF). This section describes how manufacturers must design their engines to derate power output to induce operators to take appropriate actions to ensure the SCR system is working properly. The requirements of this section apply starting in model year 2027, though you may comply with the requirements of this section in earlier model years.

(a) General provisions. The following terms and general provisions apply under this section:

(1) As described in §1036.110, this section relies on terms and requirements specified for OBD systems by California ARB in 13 CCR 1971.1 (incorporated by reference in §1036.810).

(2) The provisions of this section apply differently for low-speed vehicles. A low-speed vehicle is one whose OBD system has recorded an average speed below 20 miles per hour for the preceding 30 hours of non-idle engine operation. Non-idle engine operation includes all operating conditions except those that qualify as idle based on OBD system controls as specified in 13 CCR 1971.1(h)(5.4.10).

(3) An inducement drive cycle consists of four hours of continuous engine operation, without regard to engine starting.

(b) *Fault conditions.* Create derate strategies that monitor for and trigger an inducement based on the following conditions:

(1) DEF supply falling to a level corresponding to three hours of engine operation, based on available information on DEF consumption rates.

(2) Blocked DEF lines or dosing valves.

(3) DEF quality failing to meet your concentration specifications.

(4) Open circuit faults related to the following: DEF tank level sensor, DEF pump, DEF quality sensor, SCR wiring harness, NO_x sensors, DEF dosing valve, DEF tank heater and aftertreatment control module.

(5) Monitor for a missing catalyst.

(c) *NO_x override.* Reset the Active 100 Hour Array in the OBD system when the engine detects a fault condition identified in paragraph (b) of this section (but do not reset the Active 100 Hour Array if an additional fault occurs before the fault condition is resolved). Use NO_x sensor data to override engine derates as described in this paragraph (c) after the engine detects the fault condition. Override the onset of derating associated with a fault condition if the NO_x conversion efficiency in the Active 100 Hour Array is within 10 percent of the NO_x conversion efficiency stored in the lifetime array for OBD REAL Bin 13 and 14. The Active 100 Hour Array and the Lifetime Array are referenced in 13 CCA 1971.1(h)(5.3.2)(A) and (C), respectively. Calculate the NO_x conversion efficiency relative to the lifetime value using the following equation and override inducements if the calculated override factor is at or below 0.10:

$$\text{Override factor} = \frac{\eta_{\text{Life}} - \eta_{100}}{\eta_{\text{Life}}}$$

Where:

η = NO_x conversion efficiency = $\frac{m_{\text{in}} - m_{\text{out}}}{m_{\text{in}}}$. Use appropriate values from OBD REAL Bin 13 and 14 from the Lifetime Array for η_{Life} and from the Active 100 Hour Array for η_{100} .

m_{in} = NO_x mass entering the catalyst. Use “NO_x mass – engine out” from 13 CCA 1971.1 (h)(5.3.1)(A).

m_{out} = NO_x mass exiting catalyst. Use “NO_x mass – tailpipe” from 13 CCA 1971.1 (h)(5.3.1)(B).

(d) *Derate schedule.* Engines must follow the derate schedule described in this paragraph (d) if the engine detects a fault condition identified in paragraphs (b) and (c) of this section. The derate takes the form of a maximum drive speed for the vehicle. This maximum drive speed decreases over time based on hours of engine operation without regard to engine starting or mode of operation. Apply speed-limiting derates according to the following schedule:

Table 1 of §1036.111—Derate Schedule for Detected Faults

<u>Non-idle hours of engine operation^a</u>	<u>Default maximum speed (mi/hr)</u>	<u>Maximum speed for low-speed vehicles (mi/hr)</u>
<u>0</u>	<u>65</u>	<u>50</u>
<u>6</u>	<u>60</u>	<u>45</u>
<u>12</u>	<u>55</u>	<u>40</u>
<u>60</u>	<u>50</u>	<u>35</u>

^aHours start counting when the engine detects a fault condition specified in paragraph (b) of this section and the override factor for NO_x conversion efficiency is above 0.10. For DEF supply, you may program the engine to reset the timer to three hours when the engine detects an empty DEF tank.

(e) *Multiple and continuing faults.* The following provisions apply if the engine detects fault conditions after starting with the derate schedule specified in paragraph (d) of this section:

(1) The determination to qualify a low-speed vehicle in paragraph (a)(2) of this section applies at the point that the engine first detects a fault condition and continues to apply until the fault condition is fully resolved, as specified in paragraph (h) of this section.

(2) Apply the provisions of this section independently for each fault, except as specified in this section.

(f) *In-cab display.* The in-cab display required in §1036.110(c) must indicate the condition that triggered the pending or active derate. The display must indicate “inducement pending” as long as the system is evaluating NO_x conversion efficiency without finding that the override factor is above 0.10. Once calculated NO_x conversion efficiency confirms the fault condition, the display must identify the current stage of derating and show a countdown timer to estimate the time or distance remaining before the next stage.

(g) *Deactivating derates.* Once the override factor for NO_x conversion efficiency confirms a detected fault condition, do not use it alone to deactivate derates. Rather, program the engine to deactivate derates as follows:

(1) Evaluate whether the detected fault condition continues to apply and reset the Active 100 Hour Array in the OBD system when the fault condition no longer exists. Deactivate derates if the engine confirms that the fault condition is resolved and the override factor for NO_x conversion efficiency is at or below 0.10 for a full inducement drive schedule.

(2) Allow a generic scan tool to tentatively deactivate inducement-related fault codes while the vehicle is not in motion. Reactivate the derate at the same point in the derate schedule if the engine detects the same fault condition during a full inducement drive schedule.

(3) Treat any fault condition that recurs within 80 hours of engine operation as the same triggering condition, which would restart the derate at the same point that the system last deactivated the derate.

§ 1036.115 Other requirements.

~~(a) The warranty and maintenance requirements, adjustable parameter provisions, and defeat device prohibition of 40 CFR part 86 apply with respect to the standards of this part.~~

Engines that are required to meet the emission standards of this part must meet the following requirements, except as noted elsewhere in this part:

(a) *Crankcase emissions.* Crankcase emissions may not be discharged directly into the ambient atmosphere from any engine throughout its useful life. For purposes of this paragraph (a),

crankcase emissions that are routed to the exhaust upstream of exhaust aftertreatment during all operation are not considered to be discharged directly into the ambient atmosphere.

(b) Fuel mapping. You must perform fuel mapping for your engine as described in § 1036.510(b).

(c) Evaporative emissions. You must design and produce your engines to comply with evaporative emission standards as follows:

(1) For complete heavy-duty vehicles you produce, you must certify the vehicles to emission standards as specified in 40 CFR 1037.103.

(2) For incomplete heavy-duty vehicles, and for engines used in vehicles you do not produce, you do not need to certify your engines to evaporative emission standards or otherwise meet those standards. However, vehicle manufacturers certifying their vehicles with your engines may depend on you to produce your engines according to their specifications. Also, your engines must meet applicable exhaust emission standards in the installed configuration.

(d) Torque broadcasting. Electronically controlled engines must broadcast their speed and output shaft torque (in newton-meters). Engines may alternatively broadcast a surrogate value for determining torque. Engines must broadcast engine parameters such that they can be read with a remote device or broadcast them directly to their controller area networks. This information is necessary for testing engines in the field (see §1036.515).

(e) EPA access to broadcast information. If we request it, you must provide us any hardware, tools, and information we would need to readily read, interpret, and record all information broadcast by an engine's on-board computers and electronic control modules. If you broadcast a surrogate parameter for torque values, you must provide us what we need to convert these into torque units. We will not ask for hardware or tools if they are readily available commercially.

(f) Adjustable parameters. Engines that have adjustable parameters must meet all the requirements of this part for any adjustment in the physically adjustable range.

(1) We may require that you set adjustable parameters to any specification within the adjustable range during any testing, including certification testing, selective enforcement auditing, or in-use testing.

(2) General provisions apply for adjustable parameters as specified in 40 CFR 1068.50.

(3) DEF supply and DEF quality are adjustable parameters. The physically adjustable range includes any amount or quality of DEF that the engine's diagnostic system does not trigger inducement provisions under §1036.111.

(g) Prohibited controls. (1) General provisions. You may not design your engines with emission control devices, systems, or elements of design that cause or contribute to an unreasonable risk to public health, welfare, or safety while operating. For example, this would apply if the engine emits a noxious or toxic substance it would otherwise not emit that contributes to such an unreasonable risk.

(2) Vanadium sublimation in SCR catalysts. For engines equipped with vanadium-based SCR catalysts, you must design the engine and its emission controls to prevent vanadium sublimation and protect the catalyst from high temperatures. We will evaluate your engine design based on the following information that you must include in your application for certification:

(i) Identify the threshold temperature for vanadium sublimation for your specified SCR catalyst formulation as described in 40 CFR 1065.1113 through 1065.1121.

(ii) Describe how you designed your engine to prevent catalyst inlet temperatures from exceeding the temperature you identify in paragraph (g)(2)(i) of this section, including

consideration of engine wear through the useful life. Also describe your design for catalyst protection in case catalyst temperatures exceed the specified temperature. In your description, include how you considered elevated catalyst temperature resulting from sustained high-load engine operation, catalyst exotherms, particulate filter regeneration, and component failure resulting in unburned fuel in the exhaust stream.

(h) Defeat devices. You may not equip your engines with a defeat device. A defeat device is an auxiliary emission control device (AECD) that reduces the effectiveness of emission controls under conditions that may reasonably be expected in normal operation and use. This does not apply to auxiliary emission control devices you identify in your application for certification if any of the following is true:

(1) The conditions of concern were substantially included in the applicable procedure for duty-cycle testing as described in subpart F of this part.

(2) You show your design is necessary to prevent engine (or vehicle) damage or accidents.

(3) The reduced effectiveness applies only to starting the engine.

(4) The AECD applies only for engines that will be installed in *emergency vehicles*, and the need is justified in terms of preventing the engine from losing speed, torque, or power due abnormal conditions of the emission control system, or in terms of preventing such abnormal conditions from occurring, during operation related to emergency response. Examples of such abnormal conditions may include excessive exhaust backpressure from an overloaded particulate trap, and running out of diesel exhaust fluid for engines that rely on urea-based selective catalytic reduction.

(i) DEF tanks. Diesel exhaust fluid tanks must be sized to require refilling no more frequently than the vehicle operator will need to refill the fuel tank, even for worst-case assumptions related to fuel efficiency and refueling volumes.

(j) Special provisions for spark-ignition engines. The following provisions apply for spark-ignition engines starting with model year 2027:

(1) Catalyst bed temperature may not fall below 350 °C during extended idle. Describe how you designed your engine to meet this requirement in your application for certification. You may ask us to approve alternative strategies to prevent emissions from increasing during idle.

(2) You may use modeled exhaust component temperatures to protect the catalyst instead of designing the engine to continuously monitor exhaust component temperatures as described in this paragraph (j)(2). Measure and record component temperatures during engine mapping and during emission measurements with each required duty cycle. You may use modeled exhaust temperatures under this paragraph (j)(2) only if all modeled and actual temperatures differ by 5 °C or less. Submit a second-by-second comparison of the modeled and actual component temperatures as part of your application for certification.

§ 1036.120 Emission-related warranty requirements.

(a) General requirements. You must warrant to the ultimate purchaser and each subsequent purchaser that the new engine, including all parts of its emission control system, meets two conditions:

(1) It is designed, built, and equipped so it conforms at the time of sale to the ultimate purchaser with the requirements of this part.

(2) It is free from defects in materials and workmanship that may keep it from meeting these requirements.

(b) Warranty period. Your emission-related warranty must be valid for at least as long as the minimum warranty periods listed in this paragraph (b) in vehicle miles, or hours of engine

operation, or years in service, whichever comes first. You may offer an emission-related warranty more generous than we require. The emission-related warranty for the engine may not be shorter than any published warranty you offer with or without charge for the engine. Similarly, the emission-related warranty for any component may not be shorter than any published warranty you offer without charge for that component. If an extended warranty requires owners to pay for a portion of repairs, those terms apply in the same manner to the emission-related warranty. The warranty period begins when the vehicle is placed into service. The following minimum warranty periods apply:

Table 1 of §1036.120—Warranty by Primary Intended Service Class^a

<u>Primary Intended Service Class</u>	<u>Model year 2026 and earlier</u>	<u>Model year 2027 through 2030</u>		<u>Model year 2031 and later</u>	
	<u>Mileage</u>	<u>Mileage</u>	<u>Hours</u>	<u>Mileage</u>	<u>Hours</u>
<u>Spark-Ignition HDE</u>	<u>50,000</u>	<u>110,000</u>	<u>6,000</u>	<u>160,000</u>	<u>8,000</u>
<u>Light HDE</u>	<u>50,000</u>	<u>150,000</u>	<u>7,000</u>	<u>210,000</u>	<u>10,000</u>
<u>Medium HDE</u>	<u>100,000</u>	<u>220,000</u>	<u>11,000</u>	<u>280,000</u>	<u>14,000</u>
<u>Heavy HDE</u>	<u>100,000</u>	<u>450,000</u>	<u>22,000</u>	<u>600,000</u>	<u>30,000</u>

^aWarranty period is also expressed as 5 years for model years 2026 and earlier, 7 years for model years 2027 through 2030, and 10 years for model years 2031 and later.

(c) Components covered. The emission-related warranty covers all components whose failure would increase an engine's emissions of any regulated pollutant, including components listed in 40 CFR part 1068, appendix A, and components from any other system you develop to control emissions. The emission-related warranty covers these components even if another company produces the component.

(d) Limited applicability. You may deny warranty claims under this section if the operator caused the problem through improper maintenance or use, subject to the provisions in § 1036.125 and 40 CFR 1068.115.

(e) Owners manual. Describe in the owners manual the emission-related warranty provisions from this section that apply to the engine.

§ 1036.125 Maintenance instructions and allowable maintenance.

Maintenance includes any inspection, adjustment, cleaning, repair, or replacement of components and is classified as either emission-related or nonemission-related and each of these can be classified as either scheduled or unscheduled. Further, some emission-related maintenance is also classified as critical emission-related maintenance. Give the ultimate purchaser of each new engine written instructions for maintaining and using the engine. As described in paragraph (h) of this section, these instructions must identify how owners properly maintain and use engines for applying regulatory requirements such as emission-related warranty and defect reporting.

(a) Critical emission-related maintenance. Critical emission-related maintenance includes any adjustment, cleaning, repair, or replacement of components listed in paragraph (a)(2) of this section. This may also include other maintenance that you determine is critical, including maintenance on other critical emission-related components as defined in 40 CFR part 1068, if we

approve it in advance. You may perform scheduled critical emission-related maintenance during service accumulation on your emission-data engines at the intervals you specify.

(1) *Maintenance demonstration.* You must demonstrate that the maintenance is reasonably likely to be done at the recommended intervals on in-use engines. We will accept DEF replenishment and other SCR-related maintenance as reasonably likely to occur if your engine meets the specifications in §1036.111. We will accept other scheduled maintenance as reasonably likely to occur if you satisfy any of the following conditions:

(i) You present data showing that, if a lack of maintenance increases emissions, it also unacceptably degrades the engine's performance.

(ii) You design and produce your engines with a system we approve that displays a visible signal to alert drivers that maintenance is due, either as a result of component failure or the appropriate degree of engine or vehicle operation. The signal must clearly display "maintenance needed", "check engine", or a similar message that we approve. The signal must be continuous while the engine is operating and not be easily eliminated without performing the specified maintenance. Your maintenance instructions must specify resetting the signal after completing the specified maintenance. We must approve the method for resetting the signal. You may not design the system to be less effective at the end of the useful life or after any other degree of operation. If others install your engine in their vehicle, you may rely on installation instructions to ensure proper mounting and operation of the display. Disabling or improperly resetting the system for displaying these maintenance-related signals without performing the indicated maintenance violates the tampering prohibition in 42 U.S.C. 7522(a)(3).

(iii) You present survey data showing that at least 80 percent of engines in the field get the maintenance you specify at the recommended intervals.

(iv) You provide the maintenance free of charge and clearly say so in your maintenance instructions.

(v) You otherwise show us that the maintenance is reasonably likely to be done at the recommended intervals.

(2) *Minimum scheduled maintenance intervals.* You may not schedule replacement of catalyst beds or particulate filters during an engine's useful life. You may not schedule other critical emission-related maintenance more frequently than the minimum intervals specified in Table 1 and Table 2 of this section or otherwise allowed in this paragraph (a). The minimum intervals specified for each component applies to actuators, sensors, tubing, valves, and wiring associated with that component, except as specified.

Table 1 of 1036.125—Minimum Scheduled Maintenance Intervals for Replacement

<u>Component</u>	<u>Accumulated Miles (Hours) for Components</u>			
	<u>Spark-Ignition HDE</u>	<u>Light HDE</u>	<u>Medium HDE</u>	<u>Heavy HDE</u>
<u>Spark plugs</u>	<u>25,000 (750)</u>	<u>NA</u>	<u>NA</u>	<u>NA</u>
<u>DEF filters</u>	<u>NA</u>	<u>100,000 (3,000)</u>	<u>120,000 (3,600)</u>	<u>175,000 (5,250)</u>
<u>Crankcase ventilation valves and filters</u>	<u>60,000 (1,800)</u>	<u>60,000 (1,800)</u>	<u>60,000 (1,800)</u>	<u>60,000 (1,800)</u>
<u>Ignition wires</u>	<u>100,000 (3,000)</u>	<u>NA</u>	<u>NA</u>	<u>NA</u>
<u>Oxygen sensors</u>	<u>80,000 (2,400)</u>	<u>NA</u>	<u>NA</u>	<u>NA</u>
<u>Air injection system components</u>	<u>110,000 (3,300)</u>	<u>NA</u>	<u>NA</u>	<u>NA</u>
<u>Particulate filtration system (other than filters)</u>	<u>100,000 (3,000)</u>	<u>100,000 (3,000)</u>	<u>250,000 (7,500)</u>	<u>250,000 (7,500)</u>
<u>Catalyst systems (other than catalyst beds)</u> <u>Fuel injectors</u> <u>Electronic control modules</u> <u>Evaporative emission canisters</u> <u>Turbochargers</u> <u>EGR system components (including filters and coolers)</u>	<u>110,000 (3,300)</u>	<u>110,000 (3,300)</u>	<u>185,000 (5,550)</u>	<u>435,000 (13,050)</u>

Table 2 of 1036.125—Minimum Scheduled Maintenance Intervals for Adjustment or Cleaning

<u>Component</u>	<u>Accumulated Miles (Hours) for Components</u>			
	<u>Spark-ignition HDE</u>	<u>Light HDE</u>	<u>Medium HDE</u>	<u>Heavy HDE</u>
<u>Spark plugs</u>	<u>25,000 (750)</u>	<u>NA</u>	<u>NA</u>	<u>NA</u>
<u>EGR-related filters and coolers</u> <u>Fuel injectors</u> <u>Crankcase ventilation valves and filters</u>	<u>50,000 (1,500)</u>	<u>50,000 (1,500)</u>	<u>50,000 (1,500)</u>	<u>50,000 (1,500)</u>
<u>DEF filters</u>	<u>NA</u>	<u>50,000 (1,500)</u>	<u>50,000 (1,500)</u>	<u>50,000 (1,500)</u>
<u>Ignition wires</u> <u>Idle mixture</u>	<u>50,000 (1,500)</u>	<u>NA</u>	<u>NA</u>	<u>NA</u>
<u>Oxygen sensors</u>	<u>80,000 (2,400)</u>	<u>NA</u>	<u>NA</u>	<u>NA</u>
<u>Air injection system components</u>	<u>100,000 (3,000)</u>	<u>NA</u>	<u>NA</u>	<u>NA</u>
<u>Catalyst system components</u> <u>EGR system components (other than filters or coolers)</u> <u>Particulate filtration system components</u> <u>Turbochargers</u>	<u>100,000 (3,000)</u>	<u>100,000 (3,000)</u>	<u>150,000 (4,500)</u>	<u>150,000 (4,500)</u>

(3) *New technology.* You may ask us to approve scheduled critical emission-related maintenance of components not identified in paragraph (a)(2) of this section that is a direct result of the implementation of new technology not used in model year 2020 or earlier engines, subject to the following provisions:

(i) Your request must include your recommended maintenance interval, including data to support the need for the maintenance, and a demonstration that the maintenance is likely to occur at the recommended interval using one of the conditions specified in paragraph (a)(1) of this section.

(ii) For any such new technology, we will publish a *Federal Register* notice based on information you submit and any other available information to announce that we have established new allowable minimum maintenance intervals. Any manufacturer objecting to our decision may ask for a hearing (see §1036.820).

(b) *Recommended additional maintenance.* You may recommend any amount of maintenance that is additional to what we approve for critical emission-related components in paragraph (a) of this section for those components, as long as you state clearly that the recommended additional maintenance steps are not necessary to keep the emission-related warranty valid. If operators do the maintenance specified in paragraph (a) of this section, but not the recommended additional maintenance, this does not allow you to disqualify those engines from in-use testing or deny a warranty claim. Do not take these maintenance steps during service accumulation on your emission-data engines.

(c) *Special maintenance.* You may specify more frequent maintenance to address problems related to special situations, such as atypical engine operation. You must clearly state that this special maintenance is associated with the special situation you are addressing. We may disapprove your maintenance instructions if we determine that you have specified special maintenance steps to address engine operation that is not atypical, or that the maintenance is unlikely to occur in use. If we determine that certain maintenance items do not qualify as special

maintenance under this paragraph (c), you may identify them as recommended additional maintenance under paragraph (b) of this section.

(d) *Noncritical emission-related maintenance.* You may specify any amount of emission-related inspection or other maintenance that is not approved critical emission-related maintenance under paragraph (a) of this section, subject to the provisions of this paragraph (d). Noncritical emission-related maintenance generally includes maintenance on the components we specify in 40 CFR part 1068, appendix A, that is not covered in paragraph (a) of this section. You must state in the owners manual that these steps are not necessary to keep the emission-related warranty valid. If operators fail to do this maintenance, this does not allow you to disqualify those engines from in-use testing or deny a warranty claim. Do not take these inspection or other maintenance steps during service accumulation on your emission-data engines.

(e) *Nonemission-related maintenance.* You may schedule any amount of maintenance unrelated to emission controls that is needed for proper functioning of the engine. This might include adding engine oil; changing air, fuel, or oil filters; servicing engine-cooling systems; adjusting idle speed, governor, engine bolt torque, valve lash, injector lash, timing, or tension of air pump drive belts; and lubricating the heat control valve in the exhaust manifold. You may perform nonemission-related maintenance during service accumulation on your emission-data engines at the least frequent intervals that you recommend to the ultimate purchaser (but not the intervals recommended for special situations).

(f) *Source of parts and repairs.* State clearly on the first page of your written maintenance instructions that a repair shop or person of the owner's choosing may maintain, replace, or repair emission control devices and systems. Your instructions may not require components or service identified by brand, trade, or corporate name. Also, do not directly or indirectly condition your warranty on a requirement that the engine be serviced by your franchised dealers or any other service establishments with which you have a commercial relationship. You may disregard the requirements in this paragraph (f) if you do one of two things:

- (1) Provide a component or service without charge under the purchase agreement.
- (2) Get us to waive this prohibition in the public's interest by convincing us the engine will work properly only with the identified component or service.

(g) *Payment for scheduled maintenance.* Owners are responsible for properly maintaining their engines, which generally includes paying for scheduled maintenance. However, you may commit to paying for scheduled maintenance as described in paragraph (a)(1)(iv) of this section to demonstrate that the maintenance will occur. You may also schedule maintenance not otherwise allowed by paragraph (a)(2) of this section if you pay for it. You must pay for scheduled maintenance on any component during the useful life if it meets all the following conditions:

- (1) Each affected component was not in general use on similar engines before 1980.
- (2) The primary function of each affected component is to reduce emissions.
- (3) The cost of the scheduled maintenance is more than 2 percent of the price of the engine.
- (4) Failure to perform the maintenance would not cause clear problems that would significantly degrade the engine's performance.

(h) *Owners manual.* Include the following information in the owners manual to clarify maintenance instructions and the owner's responsibilities:

- (1) Clearly describe the scheduled maintenance steps, consistent with the provisions of this section, using nontechnical language as much as possible. Include a list of components for which you will cover scheduled replacement costs.

(2) Identify steps owners must take to qualify their engines as properly maintained, consistent with the requirements of this section. Also identify types of engine operation that would not qualify their engines as being properly used. Describe what documentation you consider appropriate for making these demonstrations. Note that you may identify failure to repair critical emission-related components as improper maintenance if the repairs are related to an observed defect.

(3) Describe how the owner can access the OBD system to troubleshoot problems and find emission-related diagnostic information and codes stored in onboard monitoring systems as described in § 1036.110(b)(9) and (c). For example, the instructions should identify the communication protocol and any other information the owner would need to read and understand stored codes.

(4) Include a general description of how the emission control systems operate.

(5) Include one or more diagrams of the engine and its emission-related components with the following information:

(i) The flow path for intake air and exhaust gas.

(ii) The flow path of evaporative and refueling emissions for spark-ignition engines, and DEF for compression-ignition engines, as applicable.

(iii) The flow path of engine coolant if it is part of the emission control system described in the application for certification.

(iv) The identity, location, and arrangement of relevant sensors, wiring, and other emission-related components in the diagram. Terminology to identify components must be consistent with codes you use for the OBD system.

(v) Expected pressures at the particulate filter and exhaust temperatures throughout the aftertreatment system.

(6) Include exploded-view drawings to allow the owner to identify the part numbers and basic assembly requirements for turbochargers, aftercoolers, and all components required for proper functioning of EGR and aftertreatment devices. Include enough detail to allow a mechanic to replace any of those components.

(7) Include basic wiring diagrams for aftertreatment-related components. Include enough detail to allow a mechanic to detect improper functioning of those components.

(8) Include the following statement: “Technical service bulletins and other information for your engine may be available at www.nhtsa.gov/recalls.”

(9) Include a troubleshooting guide to address warning signals related to DEF dosing and particulate filter regeneration that would be displayed in the cab or in a generic scan tool. The troubleshooting guide must describe the fault condition, the potential causes, the remedy, and the consequence of continuing to operate without remedy, this would include a list of all codes that cause derate or inducement (e.g., list SPN/FMI combinations) and associated operating restrictions (e.g., percent torque derate).

(10) Note that §1036.135(c)(10) requires the owners manual for an engine to be accessible electronically from a QR Code on the emission control information label.

(11) Include the following information for engines with particulate filters:

(i) Instructions on removing the particulate filter for cleaning.

(ii) Criteria for establishing that a particulate filter has been cleaned, including maximum clean filter weight and pressure drop across the filter. We recommend that you also specify a pre-installation filter weight to represent a like-new configuration.

(iii) A statement that particulate filter inlet and outlet pressures are available with a generic scan tool.

(iv) Suggested maintenance practices to prevent damage to particulate filters.

§ 1036.130 Installation instructions for vehicle manufacturers.

(a) If you sell an engine for someone else to install in a vehicle, give the engine installer instructions for installing it consistent with the requirements of this part. Include all information necessary to ensure that an engine will be installed in its certified configuration.

(b) Make sure these instructions have the following information:

(1) Include the heading: “Emission-related installation instructions”.

(2) State: “Failing to follow these instructions when installing a certified engine in a heavy-duty motor vehicle violates federal law, subject to fines or other penalties as described in the Clean Air Act.”

(3) Provide all instructions needed to properly install the exhaust system and any other components.

(4) Describe any necessary steps for installing any diagnostic system required under § 1036.11040 CFR part 86.

(5) Describe how your certification is limited for any type of application. For example, if you certify ~~H~~heavy heavy-duty enginesHDE to the CO₂ standards using only transient FTP testing, you must make clear that the engine may not be installed in tractors.

(6) Describe any other instructions to make sure the installed engine will operate according to design specifications in your application for certification. This may include, for example, instructions for installing aftertreatment devices when installing the engines.

(7) Give the following instructions if you do not ship diesel exhaust fluid tanks with your engines:

(i) Specify that vehicle manufacturers must install diesel exhaust fluid tanks meeting the specifications of §1036.115(i).

(ii) Describe how vehicle manufacturers must install diesel exhaust fluid tanks with sensors as needed to meet the requirements of §§1036.110 and 1036.111.

(87) State: “If you install the engine in a way that makes the engine’s emission control information label hard to read during normal engine maintenance, you must place a duplicate label on the vehicle, as described in 40 CFR 1068.105.”

(c) Give the vehicle manufacturer fuel map results as described in § 1036.510(b).

(d) You do not need installation instructions for engines that you install in your own vehicles.

(e) Provide instructions in writing or in an equivalent format. For example, you may post instructions on a publicly available website for downloading or printing. If you do not provide the instructions in writing, explain in your application for certification how you will ensure that each installer is informed of the installation requirements.

§ 1036.135 Labeling.

~~Label your engines as described in 40 CFR 86.007-35(a)(3), with the following additional information:~~

(a) Assign each engine a unique identification number and permanently affix, engrave, or stamp it on the engine in a legible way.[Reserved]

(b) ~~Identify the emission control system. Use terms and abbreviations as described in 40 CFR 1068.45 or other applicable conventions.~~ At the time of manufacture, affix a permanent and legible label identifying each engine. The label must meet the requirements of 40 CFR 1068.45.

- (c) ~~Identify any limitations on your certification. For example, if you certify heavy heavy-duty engines to the CO₂ standards using only transient cycle testing, include the statement “VOCATIONAL VEHICLES ONLY”. The label must –~~
- ~~(1) Include the heading "EMISSION CONTROL INFORMATION".~~
 - ~~(2) Include your full corporate name and trademark. You may identify another company and use its trademark instead of yours if you comply with the branding provisions of 40 CFR 1068.45.~~
 - ~~(3) Include EPA’s standardized designation for the engine family.~~
 - ~~(4) Identify the primary intended service class.~~
 - ~~(5) State the engine’s displacement (in liters); however, you may omit this from the label if all the engines in the engine family have the same per-cylinder displacement and total displacement.~~
 - ~~(6) State the date of manufacture [DAY (optional), MONTH, and YEAR]; however, you may omit this from the label if you stamp, engrave, or otherwise permanently identify it elsewhere on the engine, in which case you must also describe in your application for certification where you will identify the date on the engine.~~
 - ~~(7) State the FEL(s) to which the engines are certified if certification depends on the ABT provision of subpart H of this part.~~
 - ~~(8) State: "THIS ENGINE COMPLIES WITH U.S. EPA REGULATIONS FOR [MODEL YEAR] HEAVY-DUTY HIGHWAY ENGINES."~~
 - ~~(9) Identify any limitations on your certification. For example, if you certify Heavy HDE to the CO₂ standards using only steady-state testing, include the statement “TRACTORS ONLY”. Similarly, for engines with one or more approved AECDs for emergency vehicle applications under § 1036.115(h), the statement: “THIS ENGINE IS FOR INSTALLATION IN EMERGENCY VEHICLES ONLY”.~~
 - ~~(10) Include a field on the label to allow for accessing interactive information with mobile electronic devices. To do this, include an image of a QR code that will direct mobile electronic devices to a public Web site that you maintain. Generate the QR code as specified in ISO/IEC 18004 (incorporated by reference in §1036.810). To the left of the QR code, include the vertically oriented caption “Smartphone QR Code™”. The Web site associated with the QR code for a given engine must include a link to a public copy of the owners manual and the following information for that engine:
 - ~~(i) Include EPA’s standardized designation for the engine family. This may include multiple engine families in a given model year and it may include multiple model years for those families as long as the appropriate information is available for each engine.~~
 - ~~(ii) Identify the emission control system. Use terms and abbreviations as described in 40 CFR 1068.45.~~
 - ~~(iii) Identify any requirements for fuel and lubricants that do not involve fuel-sulfur levels.~~~~
- (d) You may add information to the emission control information label as follows:
- (1) You may identify other emission standards that the engine meets or does not meet. You may add the information about the other emission standards to the statement we specify, or you may include it in a separate statement.
 - (2) You may add other information to ensure that the engine will be properly maintained and used.

(3) You may add appropriate features to prevent counterfeit labels. For example, you may include the engine's unique identification number on the label.

(e) You may ask us to approve modified labeling requirements in this part 1036 if you show that it is necessary or appropriate. We will approve your request if your alternate label is consistent with the requirements of this part. We may also specify modified labeling requirements to be consistent with the intent of 40 CFR part 1037.

(f) If you obscure the engine label while installing the engine in the vehicle such that the label cannot be read during normal maintenance, you must place a duplicate label on the vehicle. If others install your engine in their vehicles in a way that obscures the engine label, we require them to add a duplicate label on the vehicle (see 40 CFR 1068.105); in that case, give them the number of duplicate labels they request and keep the following records for at least five years:

(1) Written documentation of the request from the vehicle manufacturer.

(2) The number of duplicate labels you send for each engine family and the date you sent them.

§ 1036.140 Primary intended service class and engine cycle.

You must identify a single primary intended service class for each engine family that best describes vehicles for which you design and market the engine, as follows:

(a) Divide compression-ignition engines into primary intended service classes based on the following engine and vehicle characteristics:

(1) Light ~~HDE includes engines that heavy-duty engines usually~~ are not designed for rebuild and do not have cylinder liners. Vehicle body types in this group might include any heavy-duty vehicle built from a light-duty truck chassis, van trucks, multi-stop vans, and some straight trucks with a single rear axle. Typical applications would include personal transportation, light-load commercial delivery, passenger service, agriculture, and construction. The GVWR of these vehicles is normally at or below 19,500 pounds.

(2) Medium ~~HDE includes engines that heavy-duty engines~~ may be designed for rebuild and may have cylinder liners. Vehicle body types in this group would typically include school buses, straight trucks with single rear axles, city tractors, and a variety of special purpose vehicles such as small dump trucks, and refuse trucks. Typical applications would include commercial short haul and intra-city delivery and pickup. Engines in this group are normally used in vehicles whose GVWR ranges from 19,501 to 33,000 pounds.

(3) Heavy ~~HDE includes engines that heavy-duty engines~~ are designed for multiple rebuilds and have cylinder liners. Vehicles in this group are normally tractors, trucks, straight trucks with dual rear axles, and buses used in inter-city, long-haul applications. These vehicles normally exceed 33,000 pounds GVWR.

(b) Divide spark-ignition engines into primary intended service classes as follows:

(1) Spark-ignition engines that are best characterized by paragraph (a)(1) or (2) of this section are in a separate ~~“sSpark-ignition”~~ ~~HDE~~ primary intended service class.

(2) Spark-ignition engines that are best characterized by paragraph (a)(3) of this section ~~are included in the Heavy HDE~~ primary intended service class ~~along~~ with compression-ignition engines. Gasoline-fueled engines are presumed not to be characterized by paragraph (a)(3) of this section; for example, vehicle manufacturers may install some number of gasoline-fueled engines in Class 8 trucks without causing the engine manufacturer to consider those to be ~~Hheavy HDEheavy-duty engines~~.

(c) References to “spark-ignition standards” in this part relate only to the spark-ignition engines identified in paragraph (b)(1) of this section. References to “compression-ignition standards” in

this part relate to compression-ignition engines, to spark-ignition engines optionally certified to standards that apply to compression-ignition engines, and to all engines identified under paragraph (b)(2) of this section as ~~H~~heavy ~~HDE~~heavy-duty engines.

§ 1036.150 Interim provisions.

The provisions in this section apply instead of other provisions in this part. This section describes when these interim provisions expire, if applicable.

~~(a) Early banking of greenhouse gas emissions. You may generate CO₂ emission credits for engines you certify in model year 2013 (2015 for spark-ignition engines) to the standards of § 1036.108.~~

~~(1) Except as specified in paragraph (a)(2) of this section, to generate early credits, you must certify your entire U.S.-directed production volume within that averaging set to these standards. This means that you may not generate early credits while you produce engines in the averaging set that are certified to the criteria pollutant standards but not to the greenhouse gas standards. Calculate emission credits as described in subpart H of this part relative to the standard that would apply for model year 2014 (2016 for spark-ignition engines).~~

~~(2) You may generate early credits for an individual compression-ignition engine family where you demonstrate that you have improved a model year 2013 engine model's CO₂ emissions relative to its 2012 baseline level and certify it to an FCL below the applicable standard. Calculate emission credits as described in subpart H of this part relative to the lesser of the standard that would apply for model year 2014 engines or the baseline engine's CO₂ emission rate. Use the smaller U.S.-directed production volume of the 2013 engine family or the 2012 baseline engine family. We will not allow you to generate emission credits under this paragraph (a)(2) unless we determine that your 2013 engine is the same engine as the 2012 baseline or that it replaces it.~~

~~(3) You may bank credits equal to the surplus credits you generate under this paragraph (a) multiplied by 1.50. For example, if you have 10 Mg of surplus credits for model year 2013, you may bank 15 Mg of credits. Credit deficits for an averaging set prior to model year 2014 (2016 for spark-ignition engines) do not carry over to model year 2014 (2016 for spark-ignition engines). We recommend that you notify us of your intent to use this provision before submitting your applications.~~ (a) Transitional and early credits for NO_x emissions. You may generate and use transitional and early credits for NO_x emissions according to § 1036.104(c) and subpart H of this part subject to the following provisions:

(1) Transitional credits. Model year 2024 through 2026 engines may generate transitional credits that can be used to certify model year 2027 and later engines as follows:

(i) Calculate transitional credits as described in §1036.705(b) relative to the NO_x emission standard for FTP testing in 40 CFR 86.007-11 or 86.008-10 using the useful life mileages of 40 CFR 86.004-2.

(ii) Engines must also comply with NO_x family emission limits for each duty-cycle standard other than the FTP duty cycle in § 1036.104(a) using the test procedures in subpart F of this part. Calculate these NO_x family emission limits, $FEL_{[cycle]NO_x}$, using the following equation:

$$FEL_{[cycle]NO_x} = Std_{[cycle]NO_x2027} \cdot \frac{FEL_{FTPNO_x}}{Std_{FTPNO_x2027}}$$

Eq. 1036.150-1

Where:

$Std_{[cycle]NOx2027}$ = the NO_x emission standard that applies for the applicable duty cycle under § 1036.104 for model year 2027 engines not participating in the ABT program.
 FEL_{FTPNOx} = the engine family's declared FEL for NO_x over the FTP duty cycle from § 1036.104(c)(1).

$Std_{FTPNOx2027}$ = the NO_x emission standard that applies for the FTP duty cycle under § 1036.104 for model year 2027 engines not participating in the ABT program.

Example for LLC:

$Std_{LLCNOx2027} = 90 \text{ mg/hp}\cdot\text{hr}$

$FEL_{FTPNOx} = 100 \text{ mg/hp}\cdot\text{hr}$

$Std_{FTPNOx2027} = 35 \text{ mg/hp}\cdot\text{hr}$

$$FEL_{LLCNOx} = 90 \cdot \frac{100}{35} = 257 \text{ mg/hp}\cdot\text{hr}$$

(iii) The family emission limits in this paragraph (a)(1) serve as the emission standards to determine compliance for all testing instead of the standards specified in 40 CFR 86.007-11 or 86.008-10.

(iv) Record PM, HC, and CO emission levels during all testing. Demonstrate that you comply with applicable PM, HC, and CO emission standards in 40 CFR 86.007-11 or 86.008-10.

(2) Early credits. Model year 2024 and later engines may generate early credits under this paragraph (a)(2) only if they comply with all the requirements that apply under this part for the model year to which you are certifying. Calculate early credits as described in §1036.705(b) with the following adjustments and clarifications:

(i) Calculate early credits for all model year 2030 and earlier engines relative to the NO_x standard for FTP testing in 40 CFR 86.007-11 or 86.008-10 or §1036.104 that applies for an engine family's model year.

(ii) Replace the FL term in Eq. 1036.705-1 with:

$$FL_{\text{earlycredit}} = FEL_{FTP} \cdot \frac{UL_{MY}}{UL}$$

Eq. 1036.150-2

Where:

FEL_{FTP} = the engine family's declared FEL for NO_x over the FTP duty cycle from § 1036.104(c)(1).

UL_{MY} = the required useful life, in miles, that applies for that model year.

UL = the useful life, in miles, for the future model year standard that applies for the applicable primary intended service class.

Example for model year 2026 Heavy HDE generating early credits for a model year 2028 Heavy HDE:

$FEL_{FTP} = 35 \text{ mg/hp}\cdot\text{hr}$

$UL_{MY} = 435,000 \text{ miles}$

$UL = 600,000 \text{ miles}$

$$FL_{\text{earlycredit}} = 35 \cdot \frac{435,000}{600,000} = 24.75 \text{ mg/hp}\cdot\text{hr}$$

(3) Limitations on using banked emission credits in model years 2027 and later. You must use one of the methods described in paragraphs (a)(1) and (2) of this section for using NO_x

emission credits generated by model year 2026 and earlier engines when certifying model year 2027 and later engines. Similarly, you must use the method described in paragraph (a)(2) of this section for using NO_x emission credits generated by model year 2027 through 2030 engines when certifying model year 2031 and later engines.

(b) *Model year 2014 N₂O standards.* In model year 2014 and earlier, manufacturers may show compliance with the N₂O standards using an engineering analysis. This allowance also applies for later families certified using carryover CO₂ data from model 2014 consistent with § 1036.235(d).

(c) *Engine cycle classification.* Through model year 2020, engines meeting the definition of spark-ignition, but regulated as diesel engines under ~~§1036.140~~ 40 CFR part 86, must be certified to the requirements applicable to compression-ignition engines under this part. Such engines are deemed to be compression-ignition engines for purposes of this part. Similarly, through model year 2020, engines meeting the definition of compression-ignition, but regulated as Otto-cycle under 40 CFR part 86 must be certified to the requirements applicable to spark-ignition engines under this part. Such engines are deemed to be spark-ignition engines for purposes of this part. See § 1036.140 for provisions that apply for model year 2021 and later.

(d) *Small manufacturers.* The greenhouse gas standards of this part apply on a delayed schedule for manufacturers meeting the small business criteria specified in 13 CFR 121.201. Apply the small business criteria for NAICS code 336310 for engine manufacturers with respect to gasoline-fueled engines and 333618 for engine manufacturers with respect to other engines; the employee limits apply to the total number employees together for affiliated companies. Qualifying small manufacturers are not subject to the greenhouse gas emission standards in § 1036.108 for engines with a date of manufacture on or after November 14, 2011 but before January 1, 2022. In addition, qualifying small manufacturers producing engines that run on any fuel other than gasoline, E85, or diesel fuel may delay complying with every later standard under this part by one model year. Small manufacturers may certify their engines and generate emission credits under this part ~~1036~~ before standards start to apply, but only if they certify their entire U.S.-directed production volume within that averaging set for that model year. Note that engines not yet subject to standards must nevertheless supply fuel maps to vehicle manufacturers as described in paragraph (n) of this section. Note also that engines produced by small manufacturers are subject to criteria pollutant standards.

(e) *Alternate phase-in standards for greenhouse gas emissions.* Where a manufacturer certifies all of its model year 2013 compression-ignition engines within a given primary intended service class to the applicable alternate standards of this paragraph (e), its compression-ignition engines within that primary intended service class are subject to the standards of this paragraph (e) for model years 2013 through 2016. This means that once a manufacturer chooses to certify a primary intended service class to the standards of this paragraph (e), it is not allowed to opt out of these standards. Engines certified to these standards are not eligible for early credits under paragraph (a) of this section.

Table 1 of §1036.150—Alternate Phase-In Standards

Vehicle Type	Model Years	LHD Engines	MHD Engines	HHD Engines
Tractors	2013-2015	NA	512 g/hp·hr	485 g/hp·hr
	2016 and later ^a	NA	487 g/hp·hr	460 g/hp·hr
Vocational	2013-2015	618 g/hp·hr	618 g/hp·hr	577 g/hp·hr
	2016 through 2020 ^{a+}	576 g/hp·hr	576 g/hp·hr	555 g/hp·hr

^{a4}Note: these alternate standards for 2016 and later are the same as the otherwise applicable standards for 2017 through 2020.

(f) ~~[Reserved] Separate OBD families. This paragraph (f) applies where you separately certify engines for the purpose of applying OBD requirements (for engines used in vehicles under 14,000 pounds GVWR) from non-OBD engines that could be certified as a single engine family. You may treat the two engine families as a single engine family in certain respects for the purpose of this part, as follows:~~

~~(1) This paragraph (f) applies only where the two families are identical in all respects except for the engine ratings offered and the inclusion of OBD.~~

~~(2) For purposes of this part and 40 CFR part 86, the two families remain two separate families except for the following:~~

~~(i) Specify the testable configurations of the non-OBD engine family as the testable configurations for the OBD family.~~

~~(ii) Submit the same CO₂, N₂O, and CH₄ emission data for both engine families.~~

(g) ~~Default Assigned deterioration factors~~ *for greenhouse gas standards*. You may use ~~default assigned~~ deterioration factors (DFs) without performing your own durability emission tests or engineering analysis as follows:

(1) You may use an ~~default assigned~~ additive DF of 0.0 g/hp₋hr for CO₂ emissions from engines that do not use advanced or off-cycle technologies. If we determine it to be consistent with good engineering judgment, we may allow you to use an ~~default assigned~~ additive DF of 0.0 g/hp₋hr for CO₂ emissions from your engines with advanced or off-cycle technologies.

(2) You may use an ~~default assigned~~ additive DF of 0.010 g/hp₋hr for N₂O emissions from any engine through model year 2021, and 0.020 g/hp₋hr for later model years.

(3) You may use an ~~default assigned~~ additive DF of 0.020 g/hp₋hr for CH₄ emissions from any engine.

(h) *Advanced-technology credits*. If you generate CO₂ credits from model year 2020 and earlier engines certified for advanced technology, you may multiply these credits by 1.5, except that you may not apply this multiplier and the early-credit multiplier of paragraph (a) of this section.

(i) *CO₂ credits for low N₂O emissions*. If you certify your model year 2014, 2015, or 2016 engines to an N₂O FEL less than 0.04 g/hp₋hr (provided you measure N₂O emissions from your emission-data engines), you may generate additional CO₂ credits under this paragraph (i).

Calculate the additional CO₂ credits from the following equation instead of the equation in § 1036.705:

$$\text{CO}_2 \text{ Credits-credits (Mg)} = (0.04 - \text{FEL}_{\text{N}_2\text{O}}) \cdot (\text{CF}) \cdot (\text{Volume}) \cdot (\text{UL}) \cdot (10^{-6}) \cdot (298)$$

Eq. 1036.150-3

(j) *Alternate standards under 40 CFR part 86*. This paragraph (j) describes alternate emission standards for loose engines certified under 40 CFR 86.1819-14(k)(8). The standards of §1036.108 do not apply for these engines. The standards in this paragraph (j) apply for emissions measured with the engine installed in a complete vehicle consistent with the provisions of 40 CFR 86.1819-14(k)(8)(vi). The only requirements of this part that apply to these engines are those in this paragraph (j), §§ 1036.115 through 1036.135, 1036.535, and 1036.540.

(k) [Reserved]

(l) *Credit adjustment for spark-ignition engines and light heavy-duty compression-ignition engines.* For greenhouse gas emission credits generated from model year 2020 and earlier spark-ignition and light heavy-duty engines, multiply any banked CO₂ credits that you carry forward to demonstrate compliance with model year 2021 and later standards by 1.36.

(m) *Infrequent regeneration.* For model year 2020 and earlier, you may invalidate any test interval with respect to CO₂ measurements if an infrequent regeneration event occurs during the test interval. Note that § 1036.530 specifies how to apply infrequent regeneration adjustment factors for later model years.

(n) *Supplying fuel maps.* Engine manufacturers not yet subject to standards under § 1036.108 in model year 2021 must supply vehicle manufacturers with fuel maps (or powertrain test results) as described in § 1036.130 for those engines.

(o) *Engines used in glider vehicles.* For purposes of recertifying a used engine for installation in a glider vehicle, we may allow you to include in an existing certified engine family those engines you modify (or otherwise demonstrate) to be identical to engines already covered by the certificate. We would base such an approval on our review of any appropriate documentation. These engines must have emission control information labels that accurately describe their status.

(p) *Transition to Phase 2 CO₂ standards.* If you certify all your model year 2020 engines within an averaging set to the model year 2021 FTP and SET standards and requirements, you may apply the provisions of this paragraph (p) for enhanced generation and use of emission credits. These provisions apply separately for Mmedium HDE~~heavy-duty engines~~ and Hheavy HDE~~heavy-duty engines~~.

(1) ~~GHG~~Greenhouse gas emission credits you generate with model year 2018 through 2024 engines may be used through model year 2030, instead of being limited to a five-year credit life as specified in § 1036.740(d).

(2) You may certify your model year 2024 through 2026 engines to the following alternative standards:

Table 2 of §1036.150—Alternative Standards for Model Years 2024 through 2026

Model Years	Medium Heavy-Duty-Vocational	Heavy Heavy-Duty-Vocational	Medium Heavy-Duty-Tractor	Heavy Heavy-Duty-Tractor
2024-2026	542	510	467	442

(q) *Confirmatory testing of fuel maps defined in § 1036.503(b).* For model years 2021 and later, where the results from Eq. 1036.235-1 for a confirmatory test are at or below ~~is less than or equal to~~ 2.0 %, we will not replace the manufacturer's fuel maps.

(r) [Reserved]

(s) Greenhouse gas compliance testing. Select duty cycles and measure emissions to demonstrate compliance with greenhouse gas emission standards before model year 2027 as follows:

(1) For model years 2016 through 2020, measure emissions using the FTP duty cycle specified in § 1036.510 and SET duty cycle specified in 40 CFR 86.1362, as applicable.

(2) The following provisions apply for model years 2021 through 2026:

(i) Determine criteria pollutant emissions during any testing used to demonstrate compliance with greenhouse gas emission standards; however, the duty-cycle standards of § 1036.104 apply for measured criteria pollutant emissions only as described in subpart F of this part.

(ii) You may demonstrate compliance with SET-based greenhouse gas emission standards in § 1036.108(a)(1) using the SET duty cycle specified in 40 CFR 86.1362 if you collect emissions with continuous sampling. Integrate the test results by mode to establish separate emission rates for each mode (including the transition following each mode, as applicable). Apply the CO₂ weighting factors specified in 40 CFR 86.1362 to calculate a composite emission result.

(t) [Reserved]

(u) Crankcase emissions. Through model year 2026, compression-ignition engines may discharge crankcase emissions to the ambient atmosphere if the emissions are added to the exhaust emissions (either physically or mathematically) during all emission testing. If you take advantage of this exception, you must do the following things:

(1) Manufacture the engines so that all crankcase emissions can be routed into the applicable sampling systems specified in 40 CFR part 1065.

(2) Account for deterioration in crankcase emissions when determining exhaust deterioration factors.

(v) OBD communication protocol. For model year 2026 and earlier engines, we may approve the alternative communication protocol specified in SAE J1979-2 (incorporated by reference in §1036.810) if the protocol is approved by the California Air Resources Board. The alternative protocol would apply instead of SAE J1939 and SAE J1979 as specified in 40 CFR 86.010-18(k)(1).

(w) Greenhouse gas warranty. For model year 2027 and later engines, you may ask us to approve the model year 2026 warranty periods specified in §1036.120 for components or systems needed to comply with greenhouse gas emission standards if those components or systems do not play a role in complying with criteria pollutant standards.

(x) Schedule for migrating provisions from 40 CFR part 86. This part included provisions that applied uniquely for complying with greenhouse gas standards before [INSERT DATE 30 DAYS AFTER DATE OF PUBLICATION IN THE FEDERAL REGISTER]. The following provisions apply through model year 2026:

(1) Subpart F of this part applies except as specified in this section; otherwise, you may continue to comply with the earlier version of the provisions of this part if those provisions are modified to apply for complying with both criteria pollutant standards and greenhouse gas standards.

(2) Engines exempted from the applicable standards of 40 CFR part 86 under the provisions of 40 CFR part 1068 are exempt from the standards of this part without request.

(y) Powertrain testing for criteria pollutants. You may apply the powertrain testing provisions of § 1036.101(b) for demonstrating compliance with criteria pollutant emission standards in 40 CFR part 86 before model year 2027.

Subpart C—Certifying Engine Families

§ 1036.201 General requirements for obtaining a certificate of conformity.

(a) You must send us a separate application for a certificate of conformity for each engine family. A certificate of conformity is valid from the indicated effective date until December 31 of the model year for which it is issued.

(b) The application must contain all the information required by this part and must not include false or incomplete statements or information (see §1036.255).

- (c) We may ask you to include less information than we specify in this subpart, as long as you maintain all the information required by §1036.250.
- (d) You must use good engineering judgment for all decisions related to your application (see 40 CFR 1068.5).
- (e) An authorized representative of your company must approve and sign the application.
- (f) See §1036.255 for provisions describing how we will process your application.
- (g) We may require you to deliver your test engines to a facility we designate for our testing (see §1036.235(c)). Alternatively, you may choose to deliver another engine that is identical in all material respects to the test engine, or another engine that we determine can appropriately serve as an emission-data engine for the engine family.
- (h) For engines that become new after being placed into service, such as rebuilt engines installed in new vehicles, we may specify alternate certification provisions consistent with the intent of this part. See 40 CFR 1068.120(h) and the definition of “new motor vehicle engine” in §1036.801.

§ 1036.205 Requirements for an application for certification. What must I include in my application?

Submit an application for certification as described in § 1036.201~~40 CFR 86.007-21~~, with the following additional information:

(a) Identify the engine family’s primary intended service class and dDescribe the engine family’s specifications and other basic parameters of the engine’s design and emission controls with respect to compliance with the requirements of this part. List the fuel type on which your engines are designed to operate (for example, gasoline, diesel fuel, or natural gas). For engines that can operate on multiple fuels, identify whether they are dual-fuel or flexible-fuel engines; also identify the range of mixtures for operation on blended fuels, if applicable. List each distinguishable engine configuration in the engine family. List the rated power for each engine configuration.

(b) Explain how the emission control system operates. Describe in detail all system components for controlling greenhouse gas and criteria pollutant emissions, including all auxiliary emission control devices (AECDs) and all fuel-system components you will install on any production or test engine. Identify the part number of each component you describe. For this paragraph (ab), treat as separate AECDs any devices that modulate or activate differently from each other.

Include all the following:

- (1) Give a general overview of the engine, the emission control strategies, and all AECDs.
- (2) Describe each AECD’s general purpose and function.
- (3) Identify the parameters that each AECD senses (including measuring, estimating, calculating, or empirically deriving the values). Include engine-based parameters and state whether you simulate them during testing with the applicable procedures.
- (4) Describe the purpose for sensing each parameter.
- (5) Identify the location of each sensor the AECD uses.
- (6) Identify the threshold values for the sensed parameters that activate the AECD.
- (7) Describe the parameters that the AECD modulates (controls) in response to any sensed parameters, including the range of modulation for each parameter, the relationship between the sensed parameters and the controlled parameters and how the modulation achieves the AECD’s stated purpose. Use graphs and tables, as necessary.
- (8) Describe each AECD’s specific calibration details. This may be in the form of data tables, graphical representations, or some other description.

- (9) Describe the hierarchy among the AECDs when multiple AECDs sense or modulate the same parameter. Describe whether the strategies interact in a comparative or additive manner and identify which AECD takes precedence in responding, if applicable.
- (10) Explain the extent to which the AECD is included in the applicable test procedures specified in subpart F of this part.
- (11) Do the following additional things for AECDs designed to protect engines or vehicles:
- (i) Identify any engine and vehicle design limits that make protection necessary and describe any damage that would occur without the AECD.
 - (ii) Describe how each sensed parameter relates to the protected components' design limits or those operating conditions that cause the need for protection.
 - (iii) Describe the relationship between the design limits/parameters being protected and the parameters sensed or calculated as surrogates for those design limits/parameters, if applicable.
 - (iv) Describe how the modulation by the AECD prevents engines and vehicles from exceeding design limits.
 - (v) Explain why it is necessary to estimate any parameters instead of measuring them directly and describe how the AECD calculates the estimated value, if applicable.
 - (vi) Describe how you calibrate the AECD modulation to activate only during conditions related to the stated need to protect components and only as needed to sufficiently protect those components in a way that minimizes the emission impact.
- (c) Explain in detail how the engine diagnostic system works, describing especially the engine conditions (with the corresponding diagnostic trouble codes) that cause the malfunction indicator to go on. Propose the conditions under which the diagnostic system should disregard trouble codes, as described in § 1036.110.
- (d) Describe the engines you selected for testing and the reasons for selecting them.
- (e) Describe any test equipment and procedures that you used ~~if you performed any tests that did not also involve measurement of criteria pollutants. Describe, including~~ any special or alternate test procedures you used (see § 1036.501 ~~40 CFR 1065.10(e)~~).
- (f) Describe how you operated the emission-data engine before testing, including the duty cycle and the number of engine operating hours used to stabilize emission levels. Explain why you selected the method of service accumulation. Describe any scheduled maintenance you did.
- (g) List the specifications of the test fuel to show that it falls within the required ranges we specify in 40 CFR part 1065.
- (h) Identify the engine family's useful life.
- (i) Include the maintenance instructions and warranty statement you will give to the ultimate purchaser of each new engine (see §§ 1036.120 and 1036.125).
- (j) Include the emission-related installation instructions you will provide if someone else installs your engines in their vehicles (see § 1036.130).
- (k) Describe your emission control ~~the label~~ information ~~label (see specified in~~ § 1036.135). We may require you to include a copy of the label.
- (l) Identify the duty cycle emission standards from §§ 1036.104(a) and (b) and 1036.108(a) that apply for the engine family. Also identify FELs and FCLs as follows, as applicable:
- (1) Identify the NO_x FEL over the FTP for the engine family.
 - (2) Identify the CO₂ FCLs ~~for with which you are certifying engines in~~ the engine family; also identify any FELs that apply for CH₄ and N₂O. The actual U.S.-directed production volume of configurations that have CO₂ emission rates at or below the FCL and CH₄ and

N₂O emission rates at or below the applicable standards or FELs must be at least one percent of your actual (not projected) U.S.-directed production volume for the engine family.

Identify configurations within the family that have emission rates at or below the FCL and meet the one percent requirement. For example, if your U.S.-directed production volume for the engine family is 10,583 and the U.S.-directed production volume for the tested rating is 75 engines, then you can comply with this provision by setting your FCL so that one more rating with a U.S.-directed production volume of at least 31 engines meets the FCL. Where applicable, also identify other testable configurations required under § 1036.230(b)(2).

~~(fm)~~ Identify the engine family's deterioration factors and describe how you developed them (see §§ 1036.241 and 1036.240). Present any test data you used for this.

(n) State that you operated your emission-data engines as described in the application (including the test procedures, test parameters, and test fuels) to show you meet the requirements of this part.

(go) Present emission data from all valid tests on an emission-data engine to show that you meet emission standards. Note that § 1036.235 allows you to submit an application in certain cases without new emission data. Present emission data as follows:

(1) For hydrocarbons (such as NMHC or THCE), NO_x, PM, and CO, as applicable, show your engines meet the applicable exhaust emission standards we specify in § 1036.104. Show emission figures for duty-cycle exhaust emission standards before and after applying adjustment factors for regeneration and deterioration factors for each engine.

(2) Present exhaust emission data for CO₂, CH₄, and N₂O on an emission-data engine to show that your engines meet the applicable emission standards we specify in §1036.108. Show emission figures before and after applying deterioration factors for each engine. In addition to the composite results, show individual measurements for cold-start testing and hot-start testing over the transient test cycle. For each of these tests, also include the corresponding exhaust emission data for criteria emissions. Note that § 1036.235 allows you to submit an application in certain cases without new emission data.

(23) [Reserved] If we specify more than one grade of any fuel type (for example, a summer grade and winter grade of gasoline), you need to submit test data only for one grade, unless the regulations of this part specify otherwise for your engine.

(p) State that all the engines in the engine family comply with the off-cycle emission standards we specify in §1036.104 for all normal operation and use when tested as specified in §1036.515. Describe any relevant testing, engineering analysis, or other information in sufficient detail to support your statement.

(q) We may ask you to send information to confirm that the emission data you submitted were from valid tests meeting the requirements of this part and 40 CFR part 1065. You must indicate whether there are test results from invalid tests or from any other tests of the emission-data engine, whether or not they were conducted according to the test procedures of subpart F of this part. We may require you to report these additional test results.

(r) Describe all adjustable operating parameters (see §1036.115(f)), including production tolerances. For any operating parameters that do not qualify as adjustable parameters, include a description supporting your conclusion (see 40 CFR 1068.50(c)). Include the following in your description of each adjustable parameter:

(1) For mechanically controlled parameters, include the nominal or recommended setting, the intended physically adjustable range, and the limits or stops used to establish adjustable ranges. Also include information showing why the limits, stops, or other means of inhibiting

adjustment are effective in preventing adjustment of parameters on in-use engines to settings outside your intended physically adjustable ranges.

(2) For electronically controlled parameters, describe how your engines are designed to prevent unauthorized adjustments.

(s) Provide the information to read, record, and interpret all the information broadcast by an engine's onboard computers and ECMs as described in §1036.115. State that, upon request, you will give us any hardware, software, or tools we would need to do this.

(t) Confirm that your emission-related installation instructions specify how to ensure that sampling of exhaust emissions will be possible after engines are installed in equipment and placed in service. If this cannot be done by simply adding a 20-centimeter extension to the exhaust pipe, show how to sample exhaust emissions in a way that prevents diluting the exhaust sample with ambient air.

(hu) State whether your certification is limited for certain engines. For example, you might certify engines only for use in tractors, in emergency vehicles, or in vehicles with hybrid powertrains. If this is the case, describe how you will prevent use of these engines in vehicles for which they are not certified. For example, if you certify heavy heavy-duty engines to the CO₂ standards using only transient testing, the engines may be installed only in vocational vehicles.

(iv) Unconditionally certify that all the engines in the engine family comply with the requirements of this part, other referenced parts of the CFR, and the Clean Air Act. Note that §1036.235 specifies which engines to test to show that engines in the entire family comply with the requirements of this part.

(w) Include good-faith estimates of U.S.-directed production volumes. Include a justification for the estimated production volumes if they are substantially different than actual production volumes in earlier years for similar models.

(jx) Include the information required by other subparts of this part. For example, include the information required by §1036.725 if you participate in the ABT program. ~~(k) Include the warranty statement and maintenance instructions if we request them.~~

(ly) Include other applicable information, such as information specified in this part or 40 CFR part 1068 related to requests for exemptions.

(z) Name an agent for service located in the United States. Service on this agent constitutes service on you or any of your officers or employees for any action by EPA or otherwise by the United States related to the requirements of this part.

~~(maa) For imported engines or equipment, identify the following:~~

(1) Describe your normal practice for importing engines. For example, this may include identifying the names and addresses of any agents you have authorized to import your engines. Engines imported by nonauthorized agents are not covered by your certificate.

(2) The location of a test facility in the United States where you can test your engines if we select them for testing under a selective enforcement audit, as specified in 40 CFR part 1068, subpart E.

~~(abb) Include information needed to certify vehicles to GHG-greenhouse gas standards under 40 CFR part 1037 as described in § 1036.510.~~

§ 1036.210 Preliminary approval before certification.

If you send us information before you finish the application, we may review it and make any appropriate determinations, especially for questions related to engine family definitions, auxiliary emission control devices, adjustable parameters, deterioration factors, testing for service accumulation, and maintenance. Decisions made under this section are considered to be

preliminary approval, subject to final review and approval. We will generally not reverse a decision where we have given you preliminary approval, unless we find new information supporting a different decision. If you request preliminary approval related to the upcoming model year or the model year after that, we will make best-efforts to make the appropriate determinations as soon as practicable. We will generally not provide preliminary approval related to a future model year more than two years ahead of time.

§ 1036.225 Amending ~~my~~ applications for certification.

Before we issue you a certificate of conformity, you may amend your application to include new or modified engine configurations, subject to the provisions of this section. After we have issued your certificate of conformity, you may send us an amended application **any time before the end of the model year** requesting that we include new or modified engine configurations within the scope of the certificate, subject to the provisions of this section. You must also amend your application if any changes occur with respect to any information that is included or should be included in your application.

(a) You must amend your application before you take any of the following actions:

(1) Add an engine configuration to an engine family. In this case, the engine configuration added must be consistent with other engine configurations in the engine family with respect to the **design aspects criteria** listed in § 1036.230.

(2) Change an engine configuration already included in an engine family in a way that may affect emissions, or change any of the components you described in your application for certification. This includes production and design changes that may affect emissions any time during the engine's lifetime.

(3) Modify an FEL ~~and or~~ FCL for an engine family as described in paragraph (f) of this section.

(b) To amend your application for certification, send the relevant information to the Designated Compliance Officer.

(1) Describe in detail the addition or change in the engine model or configuration you intend to make.

(2) Include engineering evaluations or data showing that the amended engine family complies with all applicable requirements. You may do this by showing that the original emission-data engine is still appropriate for showing that the amended family complies with all applicable requirements.

(3) If the original emission-data engine for the engine family is not appropriate to show compliance for the new or modified engine configuration, include new test data showing that the new or modified engine configuration meets the requirements of this part.

(4) Include any other information needed to make your application correct and complete.

(c) We may ask for more test data or engineering evaluations. You must give us these within 30 days after we request them.

(d) For engine families already covered by a certificate of conformity, we will determine whether the existing certificate of conformity covers your newly added or modified engine. You may ask for a hearing if we deny your request (see § 1036.820).

(e) The amended application applies starting with the date you submit the amended application, as follows:

(1) For engine families already covered by a certificate of conformity, you may start producing a new or modified engine configuration any time after you send us your amended application and before we make a decision under paragraph (d) of this section. However, if

we determine that the affected engines do not meet applicable requirements in this part, we will notify you to cease production of the engines and may require you to recall the engines at no expense to the owner. Choosing to produce engines under this paragraph (e) is deemed to be consent to recall all engines that we determine do not meet applicable emission standards or other requirements in this part and to remedy the nonconformity at no expense to the owner. If you do not provide information required under paragraph (c) of this section within 30 days after we request it, you must stop producing the new or modified engines.

(2) [Reserved]

(f) You may ask us to approve a change to your FEL in certain cases after the start of production, but before the end of the model year. If you change an FEL for CO₂, your FCL for CO₂ is automatically set to your new FEL divided by 1.03. The changed FEL may not apply to engines you have already introduced into U.S. commerce, except as described in this paragraph (f). You may ask us to approve a change to your FEL in the following cases:

(1) You may ask to raise your FEL for your engine family at any time ~~before the end of the model year~~. In your request, you must show that you will still be able to meet the emission standards as specified in subparts B and H of this part. Use the appropriate FELs/FCLs with corresponding production volumes to calculate emission credits for the model year, as described in subpart H of this part.

(2) You may ask to lower the FEL for your engine family only if you have test data from production engines showing that emissions are below the proposed lower FEL (or below the proposed FCL for CO₂). The lower FEL/FCL applies only to engines you produce after we approve the new FEL/FCL. Use the appropriate FELs/FCLs with corresponding production volumes to calculate emission credits for the model year, as described in subpart H of this part.

(g) You may produce engines or modify in-use engines as described in your amended application for certification and consider those engines to be in a certified configuration ~~if we approve a new or modified engine configuration during the model year under paragraph (d) of this section~~. ~~Similarly, you may modify in-use engines as described in your amended application for certification and consider those engines to be in a certified configuration if we approve a new or modified engine configuration at any time under paragraph (d) of this section.~~ Modifying a new or in-use engine to be in a certified configuration does not violate the tampering prohibition of 40 CFR 1068.101(b)(1), as long as this does not involve changing to a certified configuration with a higher family emission limit.

§ 1036.230 Selecting engine families.

~~See 40 CFR 86.001-24 for instructions on how to divide your product line into families of engines that are expected to have similar emission characteristics throughout the useful life. You must certify your engines to the standards of § 1036.108 using the same engine families you use for criteria pollutants under 40 CFR part 86. The following provisions also apply:~~

(a) For purposes of certification to the standards of this part, divide your product line into families of engines that are expected to have similar characteristics for criteria emissions throughout the useful life as described in this section. Your engine family is limited to a single model year.

(b) Group engines in the same engine family if they are the same in all the following design aspects:

(1) The combustion cycle and fuel. See paragraph (k) of this section for special provisions that apply for dual-fuel and flexible-fuel engines.

(2) The cooling system (water-cooled vs. air-cooled).

(3) Method of air aspiration, including the location of intake and exhaust valves or ports and the method of intake-air cooling, if applicable.

(4) The number, location, volume, and composition of catalytic converters or other aftertreatment devices.

(5) Cylinder arrangement (such as in-line vs. vee configurations), number of cylinders, and bore center-to-center dimensions.

(6) Method of control for engine operation other than governing (i.e., mechanical or electronic).

(7) The numerical level of the applicable criteria emission standards. For example, an engine family may not include engines certified to different family emission limits for criteria emission standards, though you may change family emission limits without recertifying as specified in §1036.225.

(c) You may subdivide a group of engines that is identical under paragraph (b) of this section into different engine families if you show the expected criteria emission characteristics are different during the useful life.

(d) In unusual circumstances, you may group engines that are not identical with respect to the design aspects listed in paragraph (b) of this section in the same engine family if you show that their criteria emission characteristics during the useful life will be similar.

(e) Engine configurations certified as hybrid engines or hybrid powertrains may not be included in an engine family with engines that have nonhybrid ~~with conventional~~ powertrains. Note that this does not prevent you from including engines in a nonhybrid ~~conventional~~ family if they are used in hybrid vehicles, as long as you certify them based on engine testing ~~conventionally~~.

(f) You must certify your engines to the greenhouse gas standards of § 1036.108 using the same engine families you use for criteria pollutants. The following additional provisions apply with respect to demonstrating compliance with the standards in § 1036.108:

(1) You may subdivide an engine family into subfamilies that have a different FCL for CO₂ emissions. These subfamilies do not apply for demonstrating compliance with criteria standards in § 1036.104.

(2) If you certify engines in the family for use as both vocational and tractor engines, you must split your family into two separate subfamilies. ~~Indicate in the application for certification that the engine family is to be split.~~

(i) Calculate emission credits relative to the vocational engine standard for the number of engines sold into vocational applications and relative to the tractor engine standard for the number of engines sold into non-vocational tractor applications. You may assign the numbers and configurations of engines within the respective subfamilies at any time before submitting the end-of-year report required by § 1036.730. If the family participates in averaging, banking, or trading, you must identify the type of vehicle in which each engine is installed; we may alternatively allow you to use statistical methods to determine this for a fraction of your engines. Keep records to document this determination.

(ii) If you restrict use of the test configuration for your split family ~~only~~ to ~~only~~ tractors, or only ~~to~~ vocational vehicles, you must identify a second testable configuration for the other type of vehicle (or an unrestricted configuration). Identify this configuration in your

application for certification. The FCL for the engine family applies for this configuration as well as the primary test configuration.

(3e) If you certify both engine fuel maps and powertrain fuel maps for an engine family, you may split the engine family into two separate subfamilies. Indicate this in your application for certification, and identify whether one or both of these sets of fuel maps applies for each group of engines. If you do not split your family, all engines within the family must conform to the engine fuel maps, including any engines for which the powertrain maps also apply.

(4e) If you certify in separate engine families engines that could have been certified in vocational and tractor engine subfamilies in the same engine family, count the two families as one family for purposes of determining your obligations with respect to the OBD requirements and in-use testing requirements ~~of 40 CFR part 86~~. Indicate in the applications for certification that the two engine families are covered by this paragraph ~~(e)(4)~~.

(5d) Except as described in this paragraph ~~(f) of this section~~, engine configurations within an engine family must use equivalent greenhouse gas emission controls. Unless we approve it, you may not produce nontested configurations without the same emission control hardware included on the tested configuration. We will only approve it if you demonstrate that the exclusion of the hardware does not increase greenhouse gas emissions.

~~(f) Engine families may be divided into subfamilies with respect to compliance with CO₂ standards.~~

(g) You may certify dual-fuel or flexible-fuel engines in a single engine family. You may include dedicated-fuel versions of this same engine model in the same engine family, as long as they are identical to the engine configuration with respect to that fuel type for the dual-fuel or flexible-fuel version of the engine. For example, if you produce an engine that can alternately run on gasoline and natural gas, you can include the gasoline-only and natural gas-only versions of the engine in the same engine family as the dual-fuel engine if engine operation on each fuel type is identical with or without installation of components for operating on the other fuel.

§ 1036.235 Testing requirements for certification.

This section describes the emission testing you must perform to show compliance with the ~~greenhouse gas~~ emission standards in §§ 1036.104 and 1036.108. ~~When testing hybrid powertrains, substitute “hybrid powertrain” for “engine” as it applies to requirements for certification.~~

(a) Select and configure a single emission-data engine from each engine family ~~as specified in 40 CFR part 86~~.

(1) For criteria pollutant emission testing, select the engine configuration most likely to exceed (or have emissions nearer to) an applicable emission standard or FEL identified in § 1036.205(e)(1). To the extent we allow it for establishing deterioration factors, select for testing those engine components or subsystems whose deterioration represents the deterioration of in-use engines.

(2) For greenhouse gas emission testing, ~~t~~he standards of this part apply only with respect to emissions measured from this tested configuration and other configurations identified in § 1036.205~~(e)~~(2). Note that configurations identified in § 1036.205~~(e)~~(2) are considered to be “tested configurations”. Whether or not you actually tested them for certification. However, you must apply the same (or equivalent) emission controls to all other engine configurations in the engine family. In other contexts, the tested configuration is sometimes referred to as the “parent configuration”, although the terms are not synonymous.

(b) Test your emission-data engines using the procedures and equipment specified in subpart F of this part. In the case of dual-fuel and flexible-fuel engines, measure emissions when operating with each type of fuel for which you intend to certify the engine. ~~(Note: measurement of criteria emissions from flexible fuel engines generally involves operation with the fuel mixture that best represents in-use operation, or with the fuel mixture with the highest emissions.)~~

(1) For criteria pollutant emission testing, measure NO_x, PM, CO, and NMHC emissions using each duty cycle specified in § 1036.104.

(2) For greenhouse gas emission testing, measure CO₂, CH₄, and N₂O emissions using the specified duty cycle(s), including cold start and hot start testing as specified in 40 CFR part 86, subpart N. ~~†~~ The following provisions apply regarding test cycles for demonstrating compliance with tractor and vocational standards:

(i) If you are certifying the engine for use in tractors, you must measure CO₂ emissions using the applicable SET specified in § 1036.501, and measure CH₄ and N₂O emissions using the specified transient cycle.

(ii) If you are certifying the engine for use in vocational applications, you must measure CO₂, CH₄, and N₂O emissions using the specified transient duty cycle, including cold-start and hot-start testing as specified in § 1036.501.

(iii) You may certify your engine family for both tractor and vocational use by submitting CO₂ emission data from both SET and transient cycle testing and specifying FCLs for both duty cycles.

(iv) Some of your engines certified for use in tractors may also be used in vocational vehicles, and some of your engines certified for use in vocational may be used in tractors. However, you may not knowingly circumvent the intent of this part (to reduce in-use emissions of CO₂) by certifying engines designed for tractors or vocational vehicles (and rarely used in the other application) to the wrong cycle. For example, we would generally not allow you to certify all your engines to the SET without certifying any to the transient cycle.

(c) We may perform confirmatory testing by measuring emissions from any of your emission-data engines. If your certification includes powertrain testing as specified in § 1036.630, this paragraph (c) also applies for the powertrain test results.

(1) We may decide to do the testing at your plant or any other facility. If we do this, you must deliver the engine to a test facility we designate. The engine you provide must include appropriate manifolds, aftertreatment devices, ~~electronic control units~~ ECMs, and other emission-related components not normally attached directly to the engine block. If we do the testing at your plant, you must schedule it as soon as possible and make available the instruments, personnel, and equipment we need.

(2) If we measure emissions on your engine, the results of that testing become the official emission results for the engine as specified in this paragraph (c). Unless we later invalidate these data, we may decide not to consider your data in determining if your engine family meets applicable requirements in this part.

(3) Before we test one of your engines, we may set its adjustable parameters to any point within the physically adjustable ranges (see § 1036.115(f)).

(4) Before we test one of your engines, we may calibrate it within normal production tolerances for anything we do not consider an adjustable parameter. For example, we may calibrate it within normal production tolerances for an engine parameter that is subject to production variability because it is adjustable during production, but is not considered an

adjustable parameter (as defined in § 1036.801) because it is permanently sealed. For parameters that relate to a level of performance that is itself subject to a specified range (such as maximum power output), we will generally perform any calibration under this paragraph (c)(4) in a way that keeps performance within the specified range.

(5) For greenhouse gas emission testing, we We may use our emission test results for steady-state, idle, cycle-average and powertrain fuel maps defined in § 1036.503(b) as the official emission results. We will not replace individual points from your fuel map.

(i) We will determine fuel masses, $m_{\text{fuel}[\text{cycle}]}$, and mean idle fuel mass flow rates, $\bar{m}_{\text{fuelidle}}$, if applicable, using both direct and indirect measurement. We will determine the result for each test point based on carbon balance error verification as the method described in § 1036.535(g)(1) and (2)(h).

(ii) We will perform this comparison using the weighted results from GEM, using vehicles that are appropriate for the engine under test. For example, we may select vehicles that the engine went into for the previous model year.

(iii) If you supply cycle-average engine fuel maps for the highway cruise cycles instead of generating a steady-state fuel map for these cycles, we may perform a confirmatory test of your engine fuel maps for the highway cruise cycles by either of the following methods:

(A) Directly measuring the highway cruise cycle-average fuel maps.

(B) Measuring a steady-state fuel map as described in paragraph (c)(5) of this section and using it in GEM to create our own cycle-average engine fuel maps for the highway cruise cycles.

(iv) We will replace fuel maps as a result of confirmatory testing as follows:

(A) Weight individual duty cycle results using the vehicle categories determined in paragraph (c)(5)(i) of this section and respective weighting factors in Table 1 of 40 CFR 1037.510 to determine a composite CO₂ emission value for each vehicle configuration; then repeat the process for all the unique vehicle configurations used to generate the manufacturer's fuel maps.

(B) The average percent difference between fuel maps is calculated using the following equation:

$$difference = \left(\frac{\sum_{i=1}^N \frac{e_{\text{CO2compEPA}i} - e_{\text{CO2compManu}i}}{e_{\text{CO2compManu}i}}}{N} \right) \cdot 100 \%$$

Eq. 1036.235-1

Where:

i = an indexing variable that represents one individual weighted duty cycle result for a vehicle configuration.

N = total number of vehicle configurations.

$e_{\text{CO2compEPA}i}$ = unrounded composite mass of CO₂ emissions in g/ton-mile for vehicle configuration i for the EPA confirmatory test.

$e_{\text{CO2compManu}i}$ = unrounded composite mass of CO₂ emissions in g/ton-mile for vehicle configuration i for the manufacturer-declared map.

(C) Where the unrounded average percent difference between our composite weighted fuel map and the manufacturer's is greater than or equal to at or below 0 %,

we will not replace the manufacturer's maps, and we will consider an individual engine to have passed the fuel map ~~confirmatory test~~.

(6) We may perform confirmatory testing with an engine dynamometer to simulate normal engine operation to determine whether your emission-data engine meets off-cycle emission standards. The accuracy margins described in § 1036.420(a) do not apply for such laboratory testing.

(d) You may ask to use carryover emission data from a previous model year instead of doing new tests, but only if all the following are true:

(1) The engine family from the previous model year differs from the current engine family only with respect to model year, items identified in § 1036.225(a), or other characteristics unrelated to emissions. We may waive this criterion for differences we determine not to be relevant.

(2) The emission-data engine from the previous model year remains the appropriate emission-data engine under paragraph (b) of this section.

(3) The data show that the emission-data engine would meet all the requirements that apply to the engine family covered by the application for certification. If the useful life for a new engine certification is longer than the useful life for the model year corresponding to the original testing, you must demonstrate that you meet the requirements of §1036.245 and §1036.246 in a way that accounts for the longer useful life for the new model year. For example, you may use carryover bench-aged deterioration factors in model year 2030 only if you originally performed bench-aging based on the useful life values for model year 2030 or if you supplement your original bench-aging procedures with additional bench-aging and emission measurements corresponding to the longer useful life that applies for model year 2030.

(e) We may require you to test a second engine of the same configuration in addition to the engine tested under paragraph (b) of this section.

(f) If you use an alternate test procedure under 40 CFR 1065.10 and later testing shows that such testing does not produce results that are equivalent to the procedures specified in subpart F of this part, we may reject data you generated using the alternate procedure.

(g) We may evaluate or test your engines to determine whether they have a defeat device before or after we issue a certificate of conformity. We may test or require testing on any vehicle or engine at a designated location, using driving cycles and conditions that may reasonably be expected in normal operation and use to investigate a potential defeat device. If we designate an engine's AECD as a possible defeat device, you must demonstrate to us that that the AECD does not reduce emission control effectiveness when the engine operates under conditions that may reasonably be expected in normal operation and use, unless one of the specific exceptions described in § 1036.115(h) applies.

§ 1036.240 Demonstrating compliance with criteria pollutant emission standards.

(a) For purposes of certification, your engine family is considered in compliance with the emission standards in § 1036.104 if all emission-data engines representing that family have test results showing official emission results and deteriorated emission levels at or below these standards (including all corrections and adjustments). This also applies for all test points for emission-data engines within the family used to establish deterioration factors. Note that your FELs are considered to be the applicable emission standards with which you must comply if you participate in the ABT program in subpart H of this part.

(b) Your engine family is deemed not to comply if any emission-data engine representing that family has test results showing an official emission result or a deteriorated emission level for any pollutant that is above an applicable emission standard (including all corrections and adjustments). Similarly, your engine family is deemed not to comply if any emission-data engine representing that family has test results showing any emission level above the applicable off-cycle emission standard for any pollutant. This also applies for all test points for emission-data engines within the family used to establish deterioration factors.

(c) To compare emission levels from the emission-data engine with the applicable duty-cycle emission standards, apply deterioration factors to the measured emission levels for each pollutant. Section 1036.245 specifies how to test your engine to develop deterioration factors that represent the deterioration expected in emissions over your engines' useful life (or intermediate useful life, as applicable). Your deterioration factors must take into account any available data from in-use testing with similar engines. Small manufacturers may use assigned deterioration factors that we establish. Apply deterioration factors as follows:

(1) Additive deterioration factor for exhaust emissions. Except as specified in paragraph (c)(2) of this section, use an additive deterioration factor for exhaust emissions. An additive deterioration factor is the difference between exhaust emissions at the end of the useful life and exhaust emissions at the low-hour test point. In these cases, adjust the official emission results for each tested engine at the selected test point by adding the factor to the measured emissions. If the factor is less than zero, use zero. Additive deterioration factors must be specified to one more decimal place than the applicable standard.

(2) Multiplicative deterioration factor for exhaust emissions. Use a multiplicative deterioration factor if good engineering judgment calls for the deterioration factor for a pollutant to be the ratio of exhaust emissions at the end of the useful life to exhaust emissions at the low-hour test point. For example, if you use aftertreatment technology that controls emissions of a pollutant proportionally to engine-out emissions, it is often appropriate to use a multiplicative deterioration factor. Adjust the official emission results for each tested engine at the selected test point by multiplying the measured emissions by the deterioration factor. If the factor is less than one, use one. A multiplicative deterioration factor may not be appropriate in cases where testing variability is significantly greater than engine-to-engine variability. Multiplicative deterioration factors must be specified to one more significant figure than the applicable standard.

(3) Sawtooth and other nonlinear deterioration patterns. The deterioration factors described in paragraphs (c)(1) and (2) of this section assume that the highest useful life emissions occur either at the end of useful life or at the low-hour test point. The provisions of this paragraph (c)(3) apply where good engineering judgment indicates that the highest useful life emissions will occur between these two points. For example, emissions may increase with service accumulation until a certain maintenance step is performed, then return to the low-hour emission levels and begin increasing again. Such a pattern may occur with battery-based electric hybrid engines. Base deterioration factors for engines with such emission patterns on the difference between (or ratio of) the point at which the highest emissions occur and the low-hour test point. Note that this applies for maintenance-related deterioration only where we allow such critical emission-related maintenance.

(4) Dual-fuel and flexible-fuel engines. In the case of dual-fuel and flexible-fuel engines, apply deterioration factors separately for each fuel type. You may accumulate service hours on a single emission-data engine using the type of fuel or the fuel mixture expected to have

the highest combustion and exhaust temperatures; you may ask us to approve a different fuel mixture if you demonstrate that a different criterion is more appropriate.

(d) Determine the official emission result for each pollutant to at least one more decimal place than the applicable standard. Apply the deterioration factor to the official emission result, as described in paragraph (c) of this section, then round the adjusted figure to the same number of decimal places as the emission standard. Compare the rounded emission levels to the emission standard for each emission-data engine.

§ 1036.241 Demonstrating compliance with greenhouse gas emission standards.

(a) For purposes of certification, your engine family is considered in compliance with the emission standards in § 1036.108 if all emission-data engines representing the tested configuration of that engine family have test results showing official emission results and deteriorated emission levels at or below the standards. Note that your FCLs are considered to be the applicable emission standards with which you must comply for certification.

(b) Your engine family is deemed not to comply if any emission-data engine representing the tested configuration of that engine family has test results showing an official emission result or a deteriorated emission level for any pollutant that is above an applicable emission standard (generally the FCL). Note that you may increase your FCL if any certification test results exceed your initial FCL.

(c) Apply deterioration factors to the measured emission levels for each pollutant to show compliance with the applicable emission standards. Your deterioration factors must take into account any available data from in-use testing with similar engines. Apply deterioration factors as follows:

(1) *Additive deterioration factor for greenhouse gas emissions.* Except as specified in paragraphs (c)(2) and (3) of this section, use an additive deterioration factor for exhaust emissions. An additive deterioration factor is the difference between the highest exhaust emissions (typically at the end of the useful life) and exhaust emissions at the low-hour test point. In these cases, adjust the official emission results for each tested engine at the selected test point by adding the factor to the measured emissions. If the factor is less than zero, use zero. Additive deterioration factors must be specified to one more decimal place than the applicable standard.

(2) *Multiplicative deterioration factor for greenhouse gas emissions.* Use a multiplicative deterioration factor for a pollutant if good engineering judgment calls for the deterioration factor for that pollutant to be the ratio of the highest exhaust emissions (typically at the end of the useful life) to exhaust emissions at the low-hour test point. Adjust the official emission results for each tested engine at the selected test point by multiplying the measured emissions by the deterioration factor. If the factor is less than one, use one. A multiplicative deterioration factor may not be appropriate in cases where testing variability is significantly greater than engine-to-engine variability. Multiplicative deterioration factors must be specified to one more significant figure than the applicable standard.

(3) *Sawtooth and other nonlinear deterioration patterns.* The deterioration factors described in paragraphs (c)(1) and (2) of this section assume that the highest useful life emissions occur either at the end of useful life or at the low-hour test point. The provisions of this paragraph (c)(3) apply where good engineering judgment indicates that the highest useful life emissions will occur between these two points. For example, emissions may increase with service accumulation until a certain maintenance step is performed, then return to the low-hour emission levels and begin increasing again. Such a pattern may occur with battery-based

electric hybrid engines. Base deterioration factors for engines with such emission patterns on the difference between (or ratio of) the point at which the highest emissions occur and the low-hour test point. Note that this applies for maintenance-related deterioration only where we allow such critical emission-related maintenance.

(4) [Reserved]

(5) *Dual-fuel and flexible-fuel engines.* In the case of dual-fuel and flexible-fuel engines, apply deterioration factors separately for each fuel type by measuring emissions with each fuel type at each test point. You may accumulate service hours on a single emission-data engine using the type of fuel or the fuel mixture expected to have the highest combustion and exhaust temperatures; you may ask us to approve a different fuel mixture if you demonstrate that a different criterion is more appropriate.

(d) Calculate emission data using measurements to at least one more decimal place than the applicable standard. Apply the deterioration factor to the official emission result, as described in paragraph (c) of this section, then round the adjusted figure to the same number of decimal places as the emission standard. Compare the rounded emission levels to the emission standard for each emission-data engine.

(e) If you identify more than one configuration in § 1036.205(e), we may test (or require you to test) any of the identified configurations. We may also require you to provide an engineering analysis that demonstrates that untested configurations listed in § 1036.205(e) comply with their FCL.

§ 1036.245 Deterioration factors for exhaust emission standards.

This section describes how to determine deterioration factors, either with an engineering analysis, with pre-existing test data, or with new emission measurements. Apply these deterioration factors to determine whether your engines will meet the duty-cycle emission standards as described in §1036.240. These standards generally apply throughout the useful life; a separate deterioration factor applies starting in model year 2031 for intermediate useful life for Heavy HDE. The provisions of this section and §1036.246 apply for all engine families starting in model year 2027; you may optionally use these provisions to determine and verify deterioration factors for earlier model years.

(a) You may ask us to approve deterioration factors for an engine family based on an engineering analysis of emission measurements from similar highway or nonroad engines if you have already given us these data for certifying the other engines in the same or earlier model years. Use good engineering judgment to decide whether the two engines are similar. We will approve your request if you show us that the emission measurements from other engines reasonably represent in-use deterioration for the engine family for which you have not yet determined deterioration factors.

(b) If you are unable to determine deterioration factors for an engine family under paragraph (a) of this section, select engines, subsystems, or components for testing. Determine deterioration factors based on service accumulation and related testing to represent the deterioration expected from in-use engines over the useful life. You may perform maintenance on emission-data engines as described in § 1036.125 and 40 CFR part 1065, subpart E. Use good engineering judgment for all aspects of the effort to establish deterioration factors under this paragraph (b). Send us your test plan for our preliminary approval under §1036.210. You may apply deterioration factors based on testing under this paragraph (b) to multiple engine families, consistent with the provisions in paragraph (a) of this section. Determine deterioration factors using one of the following procedures:

(1) Operate the emission-data engine in the certified configuration on an engine dynamometer to represent the useful life.

(i) You may accelerate the service accumulation using higher-load operation based on equivalent total fuel flow. However, the engine operation for service accumulation must also include light-load operation (or alternating light-load and high-load operation) representing in-use behavior that may contribute to aging of aftertreatment devices or systems.

(ii) Calculate deterioration factors by comparing exhaust emissions at the end of the useful life and exhaust emissions at the low-hour test point. For Heavy HDE starting in model year 2031, also calculate deterioration factors by comparing exhaust emissions at the end of intermediate useful life and exhaust emissions at the low-hour test point. Create a linear curve fit if testing includes intermediate test points. Calculate deterioration factors based on measured values, without extrapolation.

(2) Determine deterioration factors based on bench-aged aftertreatment. If you use this option, you must verify deterioration factors based on emission measurements with in-use engines as described in §1036.246.

(i) Perform bench aging of aftertreatment devices in a way that accounts for thermal and chemical degradation to represent normal engine operation over the useful life. For Heavy HDE starting in model year 2031, also account for thermal and chemical degradation to represent normal engine operation over the intermediate useful life. Use an EPA-approved bench-aging procedure or propose an equivalent procedure. For example, this might involve testing consistent with the analogous procedures that apply for light-duty vehicles under 40 CFR part 86, subpart S.

(ii) After bench-aging aftertreatment devices, install or reinstall those aftertreatment devices and systems on an emission-data engine that has been stabilized without aftertreatment (or an equivalent engine). Ensure that the engine is in an appropriate certified configuration to represent the engine family.

(iii) Measure all criteria pollutants after operating the engine with the bench-aged aftertreatment devices to stabilize emission controls for at least 100 hours on an engine dynamometer.

(iv) Calculate deterioration factors by comparing exhaust emissions with the bench-aged aftertreatment at the useful life and exhaust emissions at the low-hour test point. For Heavy HDE starting in model year 2031, also calculate deterioration factors by comparing exhaust emissions with the bench-aged aftertreatment at the intermediate useful life and exhaust emissions at the low-hour test point. Create a linear curve fit if testing includes intermediate test points. Calculate deterioration factors based on measured values, without extrapolation.

(c) If you determine deterioration factors as described in paragraph (b)(2) of this section, you may apply those deterioration factors in later years for engine families that qualify for carryover certification as described in §1036.235(d), subject to the conditions described in §1036.246. You may also apply those deterioration factors for additional engine families as described in paragraph (a) of this section.

(d) Include the following information in your application for certification:

(1) If you use test data from a different engine family, explain why this is appropriate and include all the emission measurements on which you base the deterioration factors. If the deterioration factors for the new engine family are not identical to the deterioration factors

for the different engine family, describe your engineering analysis to justify the revised values and state that all your data, analyses, evaluations, and other information are available for our review upon request.

(2) If you determined deterioration factors based on testing under paragraph (b)(1) of this section, describe your procedure for service accumulation, including a supporting rationale for any accelerated aging.

(3) If you determined deterioration factors under paragraph (b)(2) of this section, include the following information in the first year that you use those deterioration factors:

(i) Describe your bench aging or other procedures to represent full-life service accumulation for the engine's emission controls. Also describe how you prepared the test engine before and after installing aftertreatment systems to determine deterioration factors. Identify the power rating of the emission-data engine used to determine deterioration factors.

(ii) Describe your plan for verification testing under §1036.246. Include at least the following information:

(A) Identify whether you intend to test using procedures specified in §1036.246(d)(1), (2), or (3).

(B) Describe how you intend to identify candidate vehicles for testing, including consideration of how you will identify or prioritize specific vehicle types and vehicle applications to represent the engine family.

(C) Describe your intended schedule for recruiting and testing vehicles.

(D) Describe any steps you will take to ensure that selected vehicles have been properly maintained and used.

(4) If you determined deterioration factors under paragraph (b)(2) of this section, include the following information in any later year that you use those deterioration factors:

(i) Identify any changes or updates to your verification test plan that you have made in your most recent testing, or that you plan to make for later years.

(ii) Submit a report to describe any verification testing you have performed under §1036.246 as described in §1036.246(e). Include previously submitted results in addition to information related to new testing you performed for the current submission.

§ 1036.246 Verifying deterioration factors.

This section describes how to perform in-use testing to verify that your deterioration factors are appropriate. This applies for deterioration factors you determine based on testing with bench-aged aftertreatment devices or other procedures as described in §1036.245(b)(2). You may continue to use those deterioration factors for later model years with carryover engines if in-use engines meet the verification requirements of this section.

(a) Paragraph (d) of this section describes three different verification procedures you may use for measuring emissions. We may also approve your request to use an alternative verification procedure if you demonstrate that it is at least as effective as one of the specified verification procedures.

(b) Verify deterioration factors based on bench-aged aftertreatment as follows:

(1) You may use the original deterioration factors for the original model year and one additional model year, prior to the start of the year three production verification, without restriction.

(2) You must verify the original deterioration factors with testing that starts in the third year of production and continues in later production years up to and including the eighth year of production.

(3) As long as your verification test has a passing result, you may continue to use the original deterioration factors for the upcoming model year without restriction.

(4) The provisions of paragraph (h) of this section apply if your verification testing has a fail result.

(c) Select and prepare in-use engines for verification testing under this section as follows:

(1) You may recruit candidate engines any time before testing. This may involve creating a pool of candidate engines and vehicles in coordination with vehicle manufacturers and vehicle purchasers to ensure availability and to confirm a history of proper maintenance. You may meet the testing requirements of this section by repeating tests on a given engine as it ages, or you may test different engines over the course of verification testing; however, you may not choose whether to repeat tests on a given engine at a later stage based on its measured emission levels. This generally requires that you describe your plan for selecting engines in advance and justify any departures from that plan.

(2) Selected vehicles must come from independent sources, unless we approve your request to select vehicles that you own or manage. In your request, you must describe how you will ensure that the vehicle operator will drive in a way that represents normal in-use operation for the engine family.

(3) Select vehicles with installed engines from the same engine family and with the same power rating as the emission-data engine used to determine the deterioration factors. You may ask for our approval to modify engines in selected vehicles by reflashing the ECM or replacing parts to change the engines to be in a different certified configuration for proper testing. We may approve your request to modify the engines or we may waive test specifications to allow you to test in the as-received condition.

(4) You may exclude selected engines from testing if you determine that they have not been properly maintained or used. Selected engines may not have maintenance exceeding your instructions for the maintenance items specified in §1036.125(a). Selected engines must have their original aftertreatment components and be in a certified configuration. Do not perform verification testing with an engine if its critical emission-related components had a major repair other than what we allow under § 1036.125(a). You may ask us to approve replacing a critical emission-related component with an equivalent part that has undergone a comparable degree of aging.

(5) Select vehicles meeting the mileage specifications specified in Table 1 of this section for each stage of the verification testing program. If you are unable to find enough test vehicles that meet the mileage specifications, perform testing as described in this section using vehicles with the highest available mileage and describe how you will attempt to test properly qualified vehicles for later years. If this occurs in the eighth year, continue testing in future years until all tested vehicles have mileage that is at least 85 percent of the engine's useful life.

Table 1 of § 1036.246—Minimum Age Required for Obtaining In-use Engines

<u>Year of production following the initial model year that relied on the deterioration factors</u>	<u>Minimum mileage for selected vehicles as a percentage of the engine’s useful life</u>
<u>1</u>	<u>—</u>
<u>2</u>	<u>—</u>
<u>3</u>	<u>35 %</u>
<u>4</u>	<u>45 %</u>
<u>5</u>	<u>55 %</u>
<u>6</u>	<u>65 %</u>
<u>7</u>	<u>75 %</u>
<u>8</u>	<u>85 %</u>

(6) You may accelerate the testing schedule specified in paragraph (c)(5) of this section if all your test vehicles in a given year meet the mileage specifications for a later year of testing.

(d) Perform verification testing each year with one of the following procedures:

(1) Engine dynamometer testing. Measure emissions from engines equipped with in-use aftertreatment systems on an engine dynamometer as follows:

(i) Test at least two engines using the procedures specified in subpart F of this part and 40 CFR part 1065. Install the aftertreatment system from the selected in-use vehicle, including all associated wiring, sensors, and related hardware and software, on one of the following partially complete engines:

(A) The in-use engine from the same vehicle.

(B) The emission-data engine used to determine the deterioration factors.

(C) A different emission-data engine from the same engine family that has been stabilized as described in 40 CFR 1065.405(c).

(ii) Perform testing on all duty cycles with brake-specific emission standards (g/hp·hr) to determine whether the engine meets all the duty-cycle emission standards for criteria pollutants. Apply infrequent regeneration adjustment factors as specified in § 1036.522.

(iii) Evaluate verification testing for each pollutant independently. You pass the verification test if at least 70 percent of tested engines meet standards for each pollutant over all duty cycles. You fail the verification test if 70 percent or fewer engines meet standards for a given pollutant over all duty cycles.

(2) PEMS testing. Measure emissions using PEMS with in-use engines that remain installed in selected vehicles as follows:

(i) Test at least five engines using the procedures specified in § 1036.520 and 40 CFR part 1065, subpart J.

(ii) Measure emissions of NO_x, HC, and CO as the test vehicle’s normal operator drives over a regular shift-day to determine whether the engine meets all the off-cycle emission standards that applied for the engine’s original certification. Apply infrequent regeneration adjustment factors as specified in § 1036.522. For Spark-ignition HDE, calculate off-cycle emission standards for purposes of this subpart by multiplying the FTP duty-cycle standards in §1036.104(a) by 2.0 in model years 2027 through 2030 and by 1.5 in model years 2031 and later, and rounding to the same number of decimal places.

(iii) Evaluate verification testing for each pollutant independently. You pass the verification test if at least 70 percent of tested engines meet standards for each pollutant. You fail the verification test if 70 percent or fewer engines do not meet standards for a given pollutant.

(iv) You may reverse a fail determination under paragraph (d)(2)(iii) of this section by restarting and successfully completing the verification test for that year using the procedures specified in paragraph (d)(1) of this section. If you do this, you must use the verification testing procedures specified in paragraph (d)(1) of this section for all remaining years of the verification testing program.

(3) Onboard NO_x measurement. Collect on-board NO_x data from in-use engines that remain installed in selected vehicles as follows:

(i) Test at least 50 percent of engines produced using the procedures specified in § 1036.520 and 40 CFR part 1065, subpart J. Perform the overall verification of your onboard NO_x measurement system as described in 40 CFR 1065.920(b) using an engine that emits NO_x at levels at or below the off-cycle NO_x emission standard that applied for the engine's original certification. The onboard NO_x measurement system must be functional within 100 seconds of engine starting and must remain functional over the entire shift-day.

(ii) Collect NO_x data as the test vehicle's normal operator drives over a regular shift-day to determine whether the engine meets the off-cycle NO_x emission standards that applied for the engine's original certification. Apply infrequent regeneration adjustment factors as specified in § 1036.522. For Spark-ignition HDE, calculate off-cycle emission standards as described in paragraph (d)(2)(ii) of this section.

(iii) You pass the verification test if at least 70 percent of tested engines meet the off-cycle NO_x emission standard. You fail the verification test if 70 percent or fewer engines do not meet standards for a given pollutant.

(iv) You may reverse a fail determination under paragraph (d)(3)(iii) of this section by restarting and successfully completing the verification test for that year using the procedures specified in paragraph (d)(1) of this section. If you do this, you must use the verification testing procedures specified in paragraph (d)(1) of this section for all remaining years of the verification testing program.

(e) You may stop testing before you meet all the requirements of this section in the following circumstances:

(1) In a given year, you may discontinue the verification test program and concede a fail result before you meet all the testing requirements of this section. However, we may require you to do more testing before we approve revised deterioration factors under paragraph (h)(2) of this section.

(2) You may stop testing before the eight-year period specified in paragraph (c)(5) of this section if you meet all the requirements with vehicles that had mileage accumulation representing at least 85 percent of the engine family's useful life.

(f) Prepare a report to describe your verification testing each year. Include at least the following information:

(1) Identify whether you tested using the procedures specified in §1036.246(d)(1), (2), or (3).

(2) Describe how the test results support a pass or fail decision for the verification test. For in-field measurements, include continuous 1 Hz data collected over the shift-day and binned emission values determined under §1036.515.

(3) If your testing included invalid test results, describe the reasons for invalidating the data. Give us the invalid test results if we ask for them.

(4) Describe the types of vehicles selected for testing. If you determined that any selected vehicles with enough mileage accumulation were not suitable for testing, describe why you chose not to test them.

(5) For each tested engine, identify the vehicle's VIN, the engine's serial number, the engine's power rating, and the odometer reading and the engine's lifetime operating hours at the start of testing (or engine removal).

(6) State that the tested engines have been properly maintained and used and describe any noteworthy aspects of each vehicle's maintenance history. Describe the steps you took to prepare the engines for testing.

(7) For testing with engines that remain installed in vehicles, identify the date and location of testing. Also describe the ambient conditions and the driving route over the course of the shift-day.

(g) Send electronic reports to the Designated Compliance Officer using an approved information format. If you want to use a different format, send us a written request with justification.

(1) You may send us reports as you complete testing for an engine instead of waiting until you complete testing for all engines.

(2) We may ask you to send us less information in your reports than we specify in this section.

(3) We may require you to send us more information to evaluate whether your engine family meets the requirements of this part.

(4) Once you send us information under this section, you need not send that information again in later reports.

(5) We will review your test report to evaluate the results of the verification testing at each stage. We will notify you if we disagree with your conclusions, if we need additional information, or if you need to revise your testing plan for future testing.

(h) The following provisions apply if your verification test has a fail result for any deterioration factor:

(1) You may certify affected engine families for one additional model year based on the original deterioration factors. We may require you to certify with family emission limits that are at the maximum values we allow in §1036.104, or at some lower value corresponding to your measured emission results. You may not generate emission credits from affected engine families for any pollutant. We may require you to apply the revised family emission limits to recalculate emission credits and credit balances from previous model years based on your test results.

(2) You may ask us to approve revised deterioration factors for future model years based on your measured emission results. You may use such revised deterioration factors and continue verification testing under this section if the engine family still meets emission standards (or family emission limits) after applying the revised deterioration factors to the low-hour test results from an emission-data engine.

(3) Unless we approve revised deterioration factors under paragraph (h)(2) of this section, you must do new testing to establish deterioration factors after the one additional model year described in paragraph (h)(1) of this section.

(4) The provisions of this paragraph (h) apply for all engine families relying on the deterioration factors that failed to pass verification testing.

§ 1036.250 Reporting and recordkeeping for certification.

(a) ~~Within 90 days after~~ By September 30 following the end of the model year, send the Designated Compliance Officer a report including the total U.S.-directed production volume of engines you produced in each engine family during the model year (based on information available at the time of the report). Report the production by serial number and engine configuration. ~~Small manufacturers may omit this requirement.~~ You may combine this report with reports required under subpart H of this part. We may waive the reporting requirements of this paragraph (a) for small manufacturers.

(b) Organize and maintain the following records:

(1) A copy of all applications and any summary information you send us.

(2) Any of the information we specify in § 1036.205 that you were not required to include in your application.

(3) A detailed history of each emission-data engine. For each engine, describe all of the following:

(i) The emission-data engine's construction, including its origin and buildup, steps you took to ensure that it represents production engines, any components you built specially for it, and all the components you include in your application for certification.

(ii) How you accumulated engine operating hours (service accumulation), including the dates and the number of hours accumulated.

(iii) All maintenance, including modifications, parts changes, and other service, and the dates and reasons for the maintenance.

(iv) All your emission tests, including documentation on routine and standard tests, as specified in part 40 CFR part 1065, and the date and purpose of each test.

(v) All tests to diagnose engine or emission control performance, giving the date and time of each and the reasons for the test.

(vi) Any other significant events.

(4) Production figures for each engine family divided by assembly plant.

(5) Engine identification numbers for all the engines you produce under each certificate of conformity.

(c) Keep routine data from emission tests required by this part (such as test cell temperatures and relative humidity readings) for one year after we issue the associated certificate of conformity.

Keep all other information specified in this section for eight years after we issue your certificate.

(d) Store these records in any format and on any media, as long as you can promptly send us organized, written records in English if we ask for them. You must keep these records readily available. We may review them at any time.

§ 1036.255 ~~What decisions may~~ EPA ~~make regarding a~~ oversight on certificates of conformity.?

(a) If we determine an application is complete and shows that the engine family meets all the requirements of this part and the Act, we will issue a certificate of conformity for the engine family for that model year. We may make the approval subject to additional conditions.

(b) We may deny an application for certification if we determine that an engine family fails to comply with emission standards or other requirements of this part or the Clean Air Act. We will base our decision on all available information. If we deny an application, we will explain why in writing.

(c) In addition, we may deny your application or suspend or revoke a certificate of conformity if you do any of the following:

- (1) Refuse to comply with any testing or reporting requirements in this part.
 - (2) Submit false or incomplete information. This includes doing anything after submitting an application that causes submitted information to be false or incomplete.
 - (3) Cause any test data to become inaccurate.
 - (4) Deny us from completing authorized activities (see 40 CFR 1068.20). This includes a failure to provide reasonable assistance.
 - (5) Produce engines for importation into the United States at a location where local law prohibits us from carrying out authorized activities.
 - (6) Fail to supply requested information or amend an application to include all engines being produced.
 - (7) Take any action that otherwise circumvents the intent of the Act or this part.
- (d) We may void a certificate of conformity if you fail to keep records, send reports, or give us information as required under this part or the Act. Note that these are also violations of 40 CFR 1068.101(a)(2).
- (e) We may void a certificate of conformity if we find that you intentionally submitted false or incomplete information. This includes doing anything after submitting an application that causes submitted information to be false or incomplete after submission.
- (f) If we deny an application or suspend, revoke, or void a certificate, you may ask for a hearing (see § 1036.820).

Subpart D— Testing Production Engines and Hybrid Powertrains

§ 1036.301 Measurements related to GEM inputs in a selective enforcement audit.

- (a) Selective enforcement audits apply for engines as specified in 40 CFR part 1068, subpart E. This section describes how this applies uniquely in certain circumstances.
- (b) Selective enforcement audit provisions apply with respect to your fuel maps as follows:
- (1) A selective enforcement audit for an engine with respect to fuel maps would consist of performing measurements with production engines to determine fuel-consumption rates as declared for GEM simulations, and running GEM for the vehicle configurations specified in paragraph (b)(2) of this section based on those measured values. The engine is considered passing for a given configuration if the new modeled emission result for each applicable duty cycle is at or below the modeled emission result corresponding to the declared GEM inputs. The engine is considered failing if it is determined that its fuel map test result for a given configuration if the new modeled emission result for any applicable duty cycle is above the modeled emission result corresponding to the declared GEM inputs result using the manufacturer-declared fuel maps, as specified in § 1036.235(c)(5).
 - ~~(4) Because your cycle-average map may have more or fewer test points, you may have more than or fewer than the number of audit points shown in Figure 1 of this section. If the audit includes fuel-map testing in conjunction with engine testing relative to exhaust emission standards, the fuel-map simulations for the whole set of vehicles and duty cycles counts as a single test result for purposes of evaluating whether the engine family meets the pass-fail criteria under 40 CFR 1068.420. If the audit includes only fuel-map testing, determine emission results from at least three different engine configurations simulated with each applicable vehicle configuration identified in § 1036.540; the fuel-map simulation for each vehicle configuration counts as a separate test for the engine.~~

Figure 1 of § 1036.301—Sample of SEA Test Points

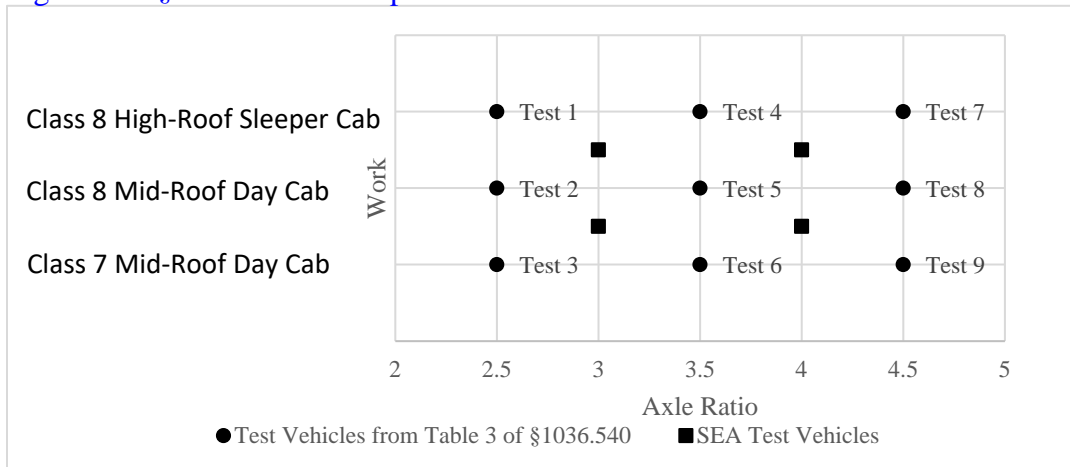

(c) If your certification includes powertrain testing as specified in 40 CFR 1036.630, these selective enforcement audit provisions apply with respect to powertrain test results as specified in 40 CFR part 1037, subpart D, and 40 CFR 1037.550. We may allow manufacturers to instead perform the engine-based testing to simulate the powertrain test as specified in 40 CFR 1037.551.

(d) We may suspend or revoke certificates for any appropriate configurations within one or more engine families based on the outcome of a selective enforcement audit.

Subpart E—In-use Testing

§ 1036.401 **Testing requirements for in-use engines**~~In-use testing.~~

(a) We may perform in-use testing of any engine family subject to the standards of this part, consistent with the Clean Air Act and the provisions of § 1036.235. ~~Note that this provision does not affect your obligation to test your in-use engines as described in 40 CFR part 86, subpart T.~~

(b) ~~This subpart describes a manufacturer-run field-testing program that applies for model year 2027 and later compression-ignition engines. Note that the testing requirements of 40 CFR part 86, subpart T, continue to apply for model year 2026 and earlier engines.~~

(c) ~~In-use test procedures for spark-ignition engines apply as described in § 1036.515. We won't require routine manufacturer-run field testing for spark-ignition engines, but the procedures of this subpart describe how to use field-testing procedures to measure emissions from engines installed in vehicles. Use good engineering judgment to apply the measurement procedures for fuels other than gasoline.~~

(d) ~~We may void your certificate of conformity for an engine family if you do not meet your obligations under this subpart. We may also void individual tests and require you to retest those vehicles or take other appropriate measures in instances where you have not performed the testing in accordance with the requirements described in this subpart.~~

§ 1036.405 **Overview of the manufacturer-run field-testing program.**

(a) ~~You must test in-use engines from the families we select. We may select the following number of engine families for testing, except as specified in paragraph (b) of this section:~~

(1) We may select up to 25 percent of your engine families in any calendar year, calculated by dividing the number of engine families you certified in the model year corresponding to the calendar year by four and rounding to the nearest whole number. We will consider only engine families with annual U.S.-directed production volumes above 1,500 units in calculating the number of engine families subject to testing each calendar year under the annual 25 percent engine family limit. If you have only three or fewer families that each exceed an annual U.S.-directed production volume of 1,500 units, we may select one engine family per calendar year for testing.

(2) Over any four-year period, we will not select more than the average number of engine families that you have certified over that four-year period (the model year when the selection is made and the preceding three model years), based on rounding the average value to the nearest whole number.

(3) We will not select engine families for testing under this subpart from a given model year if your total U.S.-directed production volume was less than 100 engines.

(b) If there is clear evidence of a nonconformity with regard to an engine family, we may select that engine family without counting it as a selected engine family under paragraph (a) of this section. For example, there may be clear evidence of a nonconformity if you certify an engine family using carryover data after reaching a fail decision under this subpart in an earlier model year without modifying the engine to remedy the problem.

(c) We may select any individual engine family for testing, regardless of its production volume, as long as we do not select more than the number of engine families described in paragraph (a) of this section. We may select an engine family from model year 2027 or any later model year.

(d) You must complete all the required testing and reporting under this subpart (for all ten test engines, if applicable), within 18 months after we approve your proposed plan for recruiting, screening, and selecting vehicles. We will typically select engine families for testing and notify you in writing by June 30 of the applicable calendar year. If you request it, we may allow additional time to send us this information.

(e) If you make a good-faith effort to access enough test vehicles to complete the testing requirements under this subpart for an engine family, but are unable to do so, you must ask us either to modify the testing requirements for the selected engine family or to select a different engine family.

(f) We may select an engine family for repeat testing in a later calendar year. Such a selection for repeat testing would count as an additional engine family for that year under paragraph (a) of this section.

(g) You may ask for approval to meet requirements under this subpart for an engine family based on information from onboard NO_x sensors that have been shown to comply with the on-board NO_x measurement system verification described in 40 CFR 1065.920(b) using an engine that emits NO_x at levels at or below the applicable standard. Any on-board NO_x measurement system must be functional within 100 seconds of engine starting and must remain functional during the entire shift-day. An alternative test program would need to rely on telematic methods to collect NO_x emission values broadly from engines in the fleet to evaluate whether emission controls are working properly across a wide range of engine operation. The alternative test program must include PEMS field-testing of at least two engines as described in this subpart, including measurement of all regulated pollutants. In your request, you must show us that the alternative program gives comparable assurance that your engines meet the NO_x standards of this part. We

may waive some or all of this subpart's requirements for the engine family if we approve your alternative test program.

§ 1036.410 Selecting and screening vehicles and engines for testing.

(a) Send us your proposed plan for recruiting, screening, and selecting vehicles. Identify the types of vehicles, location, and any other relevant criteria. We will approve your plan if it supports the objective of measuring emissions to represent a broad range of operating characteristics.

(b) Select vehicles and engines for testing that meet the following criteria:

(1) The vehicles come from at least two independent sources.

(2) Powertrain, drivetrain, emission controls, and other key vehicle and engine systems have been properly maintained and used. See § 1036.125.

(3) The engines have not been tampered with, rebuilt, or undergone major repair that could be expected to affect emissions.

(4) The engines have not been misfueled. Do not consider engines misfueled if they have used fuel meeting the specifications of §1036.415(c).

(5) The vehicles are likely to operate for at least three hours of non-idle operation over a complete shift-day, as described in § 1036.415(f).

(6) The vehicles have not exceeded the applicable useful life, in miles, hours, or years; you may otherwise not exclude engines from testing based on their age or mileage.

(7) The vehicle has appropriate space for safe and proper mounting of the portable emission measurement system (PEMS) equipment.

(c) You must notify us before disqualifying any vehicle based on the owner declining to participate, illuminated MIL or stored OBD trouble codes as described in § 1036.415(b)(2), or for any other reasons not specified in paragraph (b) of this section. For example, notify us if you disqualify any vehicle because the engine does not represent the engine family or the vehicle's usage is atypical for the particular application.

§ 1036.415 Preparing and testing engines.

(a) You must limit maintenance to what is in the owners manual for engines with that amount of service and age. For anything we consider an adjustable parameter (see § 1036.115(f)), you may adjust that parameter only if it is outside its adjustable range. You must then set the adjustable parameter to your recommended setting or the mid-point of its adjustable range, unless we approve your request to do otherwise. You must get our approval before adjusting anything not considered an adjustable parameter. You must keep records of all maintenance and adjustments, as required by § 1036.435. You must send us these records, as described in § 1036.430(a)(2)(ix), unless we instruct you not to send them.

(b) You may treat a vehicle with an illuminated MIL or stored trouble code as follows:

(1) If a candidate vehicle has an illuminated MIL or stored trouble code, either test the vehicle as received or repair the vehicle before testing. You may disqualify the vehicle only if MIL illumination or trouble code storage exceeds 12 hours. Once testing is initiated on the vehicle, you accept that the vehicle has been properly maintained and used.

(2) If a MIL illuminates or a trouble code appears on a test vehicle during a field test, stop the test and repair the vehicle. Determine test results as specified in § 1036.515 using one of the following options:

(i) Restart the testing and use only the portion of the full test results without the MIL illuminated or trouble code set.

- (ii) Initiate a new test and use only the post-repair test results.
- (3) If you determine that repairs are needed but they cannot be completed in a timely manner, you may disqualify the vehicle and replace it with another vehicle.
- (c) Use appropriate fuels for testing, as follows:
- (1) You may use any diesel fuel that meets the specifications for S15 in ASTM D975 (incorporated by reference in § 1036.810). You may use any commercially available biodiesel fuel blend that meets the specifications for ASTM D975 or ASTM D7467 (incorporated by reference in § 1036.810). You may use any gasoline fuel that meets the specifications in ASTM D4814 (incorporated by reference in § 1036.810). For other fuel types, you may use any commercially available fuel.
- (2) You may drain test vehicles' fuel tanks and refill them with diesel fuel conforming to the specifications in paragraph (c)(1) of this section.
- (3) Any fuel that is added to a test vehicle's fuel tanks must be purchased at a local retail establishment near the site of vehicle recruitment or screening, or along the test route. Alternatively, the fuel may be drawn from a central fueling source, as long as the fuel represents commercially available fuel in the area of testing.
- (4) No post-refinery fuel additives are allowed, except that specific fuel additives may be used during field testing if you can document that the test vehicle has a history of normally using the fuel treatments and they are not prohibited in the owners manual or in your published fuel-additive recommendations.
- (5) You may take fuel samples from test vehicles to ensure that appropriate fuels were used during field testing. If a vehicle fails the vehicle-pass criteria and you can show that an inappropriate fuel was used during the failed test, that particular test may be voided. You may drain vehicles' fuel tanks and refill them with diesel fuel conforming to the specifications described in paragraph (c)(1) of this section. You must report any fuel tests that are the basis of voiding a test in your report under § 1036.430.
- (d) You must test the selected engines using the test procedure described in §1036.515 while they remain installed in the vehicle. Testing consists of characterizing emission rates for moving average 300 second windows while driving, with those windows divided into bins representing different types of engine operation over a shift-day. Use one of the following methods to measure emissions:
- (1) Perform all testing with PEMS and field-testing procedures referenced in 40 CFR part 1065, subpart J. Measure emissions of HC, CO, NO_x, PM, and CO₂. You may determine HC emissions by any method specified in 40 CFR 1065.660(b).
- (2) [Reserved]
- (e) Operate the test vehicle under conditions reasonably expected during normal operation. For the purposes of this subpart, normal operation generally includes the vehicle's normal routes and loads (including auxiliary loads such as air conditioning in the cab), normal ambient conditions, and the normal driver.
- (f) Once an engine is set up for testing, test the engine for at least one shift-day. To complete a shift-day's worth of testing, start sampling at the beginning of a shift and continue sampling for the whole shift, subject to the calibration requirements of the PEMS. A shift-day is the period of a normal workday for an individual employee. Evaluate the emission data as described in § 1036.420 and include the data in the reporting and record keeping requirements specified in §§ 1036.430 and 1036.435.

(g) You may ask us to waive testing relative to one or more emission standards if you can show that field testing for such emissions is not necessary.

§ 1036.420 Pass criteria for individual engines.

Perform the following steps to determine whether an engine meets the binned emission standards in § 1036.104(a)(4):

(a) Determine the binned or shift-day emission standard, as applicable, for each regulated pollutant by adding the following accuracy margins for PEMS to the off-cycle standards in § 1036.104(a)(4) and (5).

(1) HC: 10 mg/hp·hr.

(2) CO: 0.025 g/hp·hr.

(3) PM: 6 mg/hp·hr.

(4) NO_x: 10 % of the standard.

(b) Calculate the mass emission rate for each pollutant as specified in 40 CFR part 1065, subpart G, for use in the calculations in § 1036.515.

(c) For compression-ignition engines, determine the number of windows in each bin. A bin is valid under this section only if it has more than 2,400 windows. If the 2,400 valid windows in any bin is not achieved, continue testing additional shift-days as necessary to achieve the minimum window requirements for each bin. You may idle the engine anytime during the shift day to increase the number of windows in the idle bin.

(d) An engine passes if the result for each valid bin is at or below the standard determined in paragraph (a) of this section. An engine fails if the result for any valid bin for any pollutant is above the standard determined in paragraph (a) of this section. Having no valid bins for a bin category over a shift-day does not disqualify an engine from pass-fail determinations under this paragraph (d).

§ 1036.425 Pass criteria for engine families.

For testing with PEMS under §1036.415(d)(1), determine the number of engines you must test from each selected engine family and the family pass criteria as follows:

(a) Start by measuring emissions from five engines using the procedures described in this subpart E and §1036.515. If all five engines comply fully with the off-cycle bin standards, the engine family passes, and you may stop testing.

(b) If only one of the engines tested under paragraph (a) of this section does not comply fully with the off-cycle bin standards, test one more engine. If this additional engine complies fully with the off-cycle bin standards, the engine family passes, and you may stop testing.

(c) If two or more engines tested under paragraphs (a) and (b) of this section do not comply fully with the off-cycle bin standards, test additional engines until you have tested a total of ten engines. Calculate the arithmetic mean of the sum-over-sum emissions from the ten engine tests as specified in § 1036.515(g) for each pollutant. If the results are at or below the off-cycle bin standards, the engine family passes. If the result for any pollutant is above an off-cycle bin standard, the engine family fails.

§ 1036.430 Reporting requirements.

(a) Report content. Prepare test reports as follows:

(1) Include the following for each engine family:

(i) Describe how you recruited vehicles. Describe how you used any criteria or thresholds to narrow your search or to screen individual vehicles.

(ii) Include a summary of the vehicles you have disqualified and the reasons you disqualified them, whether you base the disqualification on the criteria in § 1036.410(b) or anything else. If you disqualified a vehicle due to misfueling, include the results of any fuel sample tests. If you reject a vehicle due to tampering, describe how you determined that tampering occurred.

(iii) Identify how many engines you have tested from the applicable engine family and how many engines still need to be tested. Identify how many tested engines have passed or failed under §1036.420.

(iv) After the final test, report the results and state the outcome of testing for the engine family based on the criteria in § 1036.425.

(v) Describe any incomplete or invalid tests that were conducted under this subpart.

(2) Include the following information for the test vehicle:

(i) The EPA engine-family designation, and the engine's model number, total displacement, and power rating.

(ii) The date EPA selected the engine family for testing.

(iii) The vehicle's make and model and the year it was built.

(iv) The vehicle identification number and engine serial number.

(v) The vehicle's type or application (such as delivery, line haul, or dump truck). Also, identify the type of trailer, if applicable.

(vi) The vehicle's maintenance and use history.

(vii) The known status history of the vehicle's OBD system and any actions taken to address OBD trouble codes or MIL illumination over the vehicle's lifetime.

(viii) Any OBD codes or MIL illumination that occur after you accept the vehicle for field testing under this subpart.

(ix) Any steps you take to maintain, adjust, modify, or repair the vehicle or its engine to prepare for or continue testing, including actions to address OBD trouble codes or MIL illumination. Include any steps you took to drain and refill the vehicle's fuel tank(s) to correct misfueling, and the results of any fuel test conducted to identify misfueling.

(3) Include the following data and measurements for each test vehicle:

(i) The date and time of testing, and the test number.

(ii) Number of shift-days of testing (see § 1036.415(f)).

(iii) Route and location of testing. You may base this description on the output from a global-positioning system (GPS).

(iv) The steps you took to ensure that vehicle operation during testing was consistent with normal operation and use, as described in § 1036.415(e).

(v) Fuel test results, if fuel was tested under §§ 1036.410 or 1036.415.

(vi) The vehicle's mileage at the start of testing. Include the engine's total lifetime hours of operation, if available.

(vii) The number of windows in each bin (see § 1036.420(c)).

(viii) The bin emission value per vehicle for each pollutant. Describe the method you used to determine HC as specified in 40 CFR 1065.660(b).

(ix) Recorded 1 Hz test data for at least the following parameters, noting that gaps in the 1 Hz data file over the shift-day are only allowed during analyzer zero and span verifications:

(A) Ambient temperature.

(B) Ambient pressure.

(C) Ambient humidity.

(D) Altitude.

(E) Emissions of HC, CO, CO₂, and NO_x. Report results for PM if it was measured in a manner that provides 1 Hz test data.

(F) Differential backpressure of any PEMS attachments to vehicle exhaust.

(G) Exhaust flow.

(H) Exhaust aftertreatment temperatures.

(I) Engine speed.

(J) Engine brake torque.

(K) Engine coolant temperature

(L) Intake manifold temperature.

(M) Intake manifold pressure.

(N) Throttle position.

(O) Any parameter sensed or controlled to modulate the emission control system or fuel-injection timing.

(4) Include the following summary information after you complete testing with each engine:

(i) State whether the engine meets the off-cycle standards for each bin for each pollutant as described in § 1036.420(d).

(ii) Describe if any testing or evaluations were conducted to determine why a vehicle failed the off-cycle emission standards described in § 1036.420.

(iii) Describe the purpose of any diagnostic procedures you conduct.

(iv) Describe any instances in which the OBD system illuminated the MIL or set trouble codes. Also describe any actions taken to address the trouble codes or MIL.

(v) Describe any instances of misfueling, the approved actions taken to address the problem, and the results of any associated fuel sample testing.

(b) *Submission.* Send electronic reports to the Designated Compliance Officer using an approved information format. If you want to use a different format, send us a written request with justification.

(1) You may send us reports as you complete testing for an engine instead of waiting until you complete testing for all engines.

(2) We may ask you to send us less information in your reports than we specify in this section.

(3) We may require you to send us more information to evaluate whether your engine family meets the requirements of this part.

(4) Once you send us information under this section, you need not send that information again in later reports.

(c) *Additional notifications.* Notify the Designated Compliance Officer describing progress toward completing the required testing and reporting under this subpart, as follows:

(1) Notify us once you complete testing for an engine.

(2) Notify us if your review of the test data for an engine family indicates that two of the first five tested engines have failed to comply with the vehicle-pass criteria in §1036.420(d).

(3) Notify us if your review of the test data for an engine family indicates that the engine family does not comply with the family-pass criteria in § 1036.425(c).

(4) Describe any voluntary vehicle/engine emission evaluation testing you intend to conduct with PEMS on the same engine families that are being tested under this subpart, from the

time that engine family was selected for field testing under § 1036.405 until the final results of all testing for that engine family are reported to us under this section.

§ 1036.435 Recordkeeping requirements.

Keep the following paper or electronic records of your field testing for five years after you complete all the testing required for an engine family:

(a) Keep a copy of the reports described in § 1036.430.

(b) Keep any additional records, including forms you create, related to any of the following:

(1) The recruitment, screening, and selection process described in § 1036.410, including the vehicle owner's name, address, phone number, and e-mail address.

(2) Pre-test maintenance and adjustments to the engine performed under § 1036.415.

(3) Test results for all void, incomplete, and voluntary testing described in § 1036.430.

(4) Evaluations to determine why a vehicle failed any of the bin standards described in § 1036.420.

(c) Keep a copy of the relevant calibration results required by 40 CFR part 1065.

§ 1036.440 Warranty obligations related to in-use testing.

Testing under this subpart that finds an engine exceeding emission standards under this subpart is not by itself sufficient to show a breach of warranty under 42 U.S.C. 7541(a)(1). A breach of warranty would also require one of the following:

(a) That the engine or vehicle, as designed, built, and equipped at the time of sale, does not conform in all material respects reasonably related to emission controls to the engine as described in the application for certification and covered by the certificate.

(b) A defect in a component's materials or workmanship causes the vehicle or engine to fail to conform to the applicable regulations for its useful life.

Subpart F—Test Procedures

§ 1036.501 General testing provisions.~~How do I run a valid emission test?~~

~~(a) Use the equipment and procedures specified in this subpart and 40 CFR ~~86.1305~~part 1065 to determine whether engines meet the emission standards in §§ ~~1036.104 and~~ 1036.108.~~

~~(b) You may use special or alternate procedures to the extent we allow them under 40 CFR 1065.10.~~

~~(c) This subpart is addressed to you as a manufacturer, but it applies equally to anyone who does testing for you, and to us when we perform testing to determine if your engines meet emission standards.~~

~~(d) For engines that use aftertreatment technology with infrequent regeneration events, apply infrequent regeneration adjustment factors as described in § 1036.52230.~~

~~(e) Test hybrid engines as described in § 1036.525 and 40 CFR part 1065.~~

~~(f) Determine engine fuel maps as described in § 1036.5103(b).~~

~~(g) The following additional provisions apply for testing to demonstrate compliance with the emission standards in § 1036.108 for model year 2016 through 2020 engines:~~

~~(1) Measure CO₂, CH₄, and N₂O emissions using the transient cycle specified in either 40 CFR 86.1333 or § 1036.510.~~

~~(2) For engines subject to SET testing under § 1036.108(a)(1), measure CO₂ emissions using the SET specified in 40 CFR 86.1362.~~

(h) The following additional provisions apply for testing to demonstrate compliance with the emission standards in § 1036.108 for model year 2021 and later engines:

(1) If your engine is intended for installation in a vehicle equipped with stop-start technology, you may turn the engine off during the idle portions of the duty cycle to represent in-use operation, consistent with good engineering judgment. We recommend installing an engine starter motor and allowing the engine's Electronic Control Unit (ECU) to control the engine stop and start events.

(2) For engines subject to SET testing under § 1036.108(a)(1), use one of the following methods to measure CO₂ emissions:

(i) Use the SET duty cycle specified in § 1036.505 using either continuous or batch sampling.

(ii) Measure CO₂ emissions over the SET duty cycle specified in 40 CFR 86.1362 using continuous sampling. Integrate the test results by mode to establish separate emission rates for each mode (including the transition following each mode, as applicable). Apply the CO₂ weighting factors specified in 40 CFR 86.1362 to calculate a composite emission result.

(3) Measure CO₂, CH₄, and N₂O emissions over the transient cycle specified in either 40 CFR 86.1333 or § 1036.510.

(4) Measure or calculate emissions of criteria pollutants corresponding to your measurements to demonstrate compliance with CO₂ standards in subpart B of this part. These test results are not subject to the duty cycle standards of 40 CFR part 86, subpart A. If your engine is intended for installation in a vehicle equipped with stop-start technology, you may turn the engine off during idle portions of the duty cycle to represent in-use operation. We recommend installing a production engine starter motor and allowing the engine's ECM to manipulate the starter motor to control the engine stop and start events.

§ 1036.503 Engine data and information for to support vehicle certification.

You must give vehicle manufacturers information as follows so they can certify their model year 2021 and later vehicles to greenhouse gas emission standards under 40 CFR part 1037:

(a) Identify engine make, model, fuel type, combustion type, engine family name, calibration identification, and engine displacement. Also identify whether the engines meet CO₂ standards for tractors, vocational vehicles, or both ~~which standards the engines meet.~~

(b) This paragraph (b) describes four different methods to generate engine fuel maps. For engines without hybrid components and for mild hybrid engines where you do not choose not to include hybrid components in the test, you must generate fuel maps using either paragraph (b)(1) or (2) of this section. For mild other hybrid engines, where you choose to include the hybrid components in the test and for hybrid engines, you must generate fuel maps using paragraph (b)(43) of this section. For all other hybrids, powertrains, and for vehicles where the transmission is not automatic, automated manual, manual, or dual-clutch, generate fuel maps using you must use paragraph (b)(34) of this section.

(1) ~~Combined steady state and cycle average.~~ Determine steady-state engine fuel maps as described in § 1036.535(b). Determine ~~and~~ fuel consumption at idle as described in § 1036.535(b) ~~and~~ (c) ~~respectively, and d.~~ Determine cycle-average engine fuel maps as described in § 1036.540, excluding cycle-average fuel maps for highway cruise cycles.

(2) Determine steady-state fuel maps as described in either §1036.535(b) or (d). Cycle average. Determine fuel consumption at idle as described in § 1036.535(c). D~~and (d), and~~ determine cycle-average engine fuel maps as described in § 1036.540, including cycle-average engine fuel maps for highway cruise cycles. W, ~~you do not need to determine steady state engine fuel maps under § 1036.535(b). Fuel mapping for highway cruise cycles~~

~~using cycle-average testing is an alternate method, which means that we may do confirmatory testing by creating cycle-average fuel maps from based on steady-state fuel maps created in paragraph (b)(1) of this section~~ing for highway cruise cycles ~~even if you do not; however, we will use the steady state fuel maps to create cycle average fuel maps.~~ In § 1036.540 we define the vehicle configurations for testing; we may add more vehicle configurations to better represent your engine's operation for the range of vehicles in which your engines will be installed (see 40 CFR 1065.10(c)(1)).

(3) Determine fuel consumption at idle as described in § 1036.535(c) and (d), and determine cycle-average engine fuel maps as described in 40 CFR 1037.550, including cycle-average engine fuel maps for highway cruise cycles.

~~(4) Powertrain.~~ Generate a powertrain fuel maps as described in 40 CFR 1037.550. ~~In this case, you do not need to perform instead of fuel mapping under § 1036.535 or § 1036.540. The Note that the option in 40 CFR 1037.550(b)(2) is only-allowed only for hybrid powertrain-engine testing.~~

~~(4) Hybrid engine. Determine fuel consumption at idle as described in § 1036.535(c) and (d), and determine cycle-average engine fuel maps as described in § 1037.550, including cycle-average engine fuel maps for highway cruise cycles.~~

(c) Provide the following information if you generate engine fuel maps using either paragraph (b)(1), (2), or ~~(3)~~4 of this section:

(1) Full-load torque curve for installed engines; and the full-load torque curve of the engine (parent engine) with the highest fueling rate that shares the same engine hardware, including the turbocharger, as described in 40 CFR 1065.510. You may use 40 CFR 1065.510(b)(5)(i) for ~~engines subject to S~~spark-ignition ~~HDE~~standards. Measure the torque curve for hybrid engines that have an RESS as described in 40 CFR 1065.510(g)(2) with the hybrid system active. Test hybrid engines with no RESS as described in~~For hybrid engines that do not include an RESS follow~~ 40 CFR 1065.510(b)(5)(ii).

(2) Motoring torque ~~map~~curve as described in 40 CFR 1065.510(c)(2) and (5) for conventional and hybrid engines, respectively. For engines with a low-speed governor, remove data points where the low-speed governor is active. If you don't know when the low-speed governor is active, we recommend removing all points below 40 r/min above the ~~low~~warm low-idle speed.

(3) Declared engine idle speed. For vehicles with manual transmissions, this is the engine speed with the transmission in neutral. For all other vehicles, this is the engine's idle speed when the transmission is in drive.

(4) The engine idle speed during the transient cycle-average fuel map.

(5) The engine idle torque during the transient cycle-average fuel map.

(d) If you generate powertrain fuel maps using paragraph (b)~~(3)~~4 of this section, determine the system continuous rated power according to § 1036.527.

§ 1036.505 Supplemental Emission Test.

(a) ~~Starting in model year 2021, you must m~~Measure CO₂ emissions using the steady-state SET duty cycle in 40 CFR 86.1362 as described in § 1036.501, or using the SET duty cycle as described in this section. Note that the SET duty cycle is operated as a ramped-modal cycle rather than discrete steady-state test points.

(b) Perform SET testing with one of the following procedures:

(1) For testing nonhybrid engines testing, the SET duty cycle is based on normalized speed and torque values relative to certain maximum values. Denormalize speed as described in 40

CFR 1065.512. Denormalize torque as described in 40 CFR 1065.610(d). ~~Denormalize speed as described in 40 CFR 1065.512.~~

(2) ~~For Test hybrid powertrain engines and hybrid engine powertrains as described in testing, follow 40 CFR 1037.550, except as specified in this paragraph (b)(2). to carry out the test, but do~~ Do not compensate the duty cycle for the distance driven as described in 40 CFR 1037.550(g)(4). ~~f. For hybrid engines, select the transmission from Table 1 of § 1036.540, substituting “engine” for “vehicle” and “highway cruise cycle” for “SET”, and cycles do not follow. Disregard duty cycles in~~ 40 CFR 1037.550(j). For cycles that begin with a set of contiguous idle points, leave the transmission in neutral or park for the full initial idle segment. Place the transmission into drive ~~within no earlier than~~ 5 seconds ~~of before~~ the first nonzero vehicle speed setpoint. ~~For SET testing only, place~~ Place the transmission into park or neutral when the cycle reaches ~~the final idle segment~~ SET mode 14. Use the following vehicle parameters ~~instead place~~ of those in 40 CFR 1037.550 to define the vehicle model in 40 CFR 1037.550(a)(3):

(i) Determine the vehicle test mass, M , as follows:

$$M = 15.1 \cdot P_{\text{contrated}}^{1.31}$$

Eq. 1036.505-1

Where:

$P_{\text{contrated}}$ = the continuous rated power of the hybrid system determined in § 1036.527.

Example:

$$P_{\text{contrated}} = 350.1 \text{ kW}$$

$$M = 15.1 \cdot 350.1^{1.31} = 32499 \text{ kg}$$

(ii) Determine the vehicle frontal area, A_{front} , as follows:

(A) For $M \leq 18050$ kg:

$$A_{\text{front}} = -1.69 \cdot 10^{-8} \cdot M^2 + 6.33 \cdot 10^{-4} \cdot M + 1.67 \text{ Eq. 1036.505-2}$$

Example:

$$M = 16499 \text{ kg}$$

$$A_{\text{front}} = -1.69 \cdot 10^{-8} \cdot 16499^2 + 6.33 \cdot 10^{-4} \cdot 16499 + 1.67 = 7.51 \text{ m}^2$$

(B) For $M > 18050$ kg, $A_{\text{front}} = 7.59 \text{ m}^2$

(iii) Determine the vehicle drag area, $C_d A$, as follows:

$$C_d A = \frac{(0.00299 \cdot A_{\text{front}} - 0.000832) \cdot 2 \cdot g \cdot 3.6^2}{\rho}$$

Eq. 1036.505-3

Where:

g = gravitational constant = 9.80665 m/s².

ρ = air density at reference conditions. Use $\rho = 1.1845 \text{ kg/m}^3$.

Example:

$$C_d A = \frac{(0.00299 \cdot 7.59 - 0.000832) \cdot 2 \cdot 9.80665 \cdot 3.6^2}{1.1845} = 3.08 \text{ m}^2$$

(iv) Determine the coefficient of rolling resistance, C_{rr} , as follows:

$$C_{rr} = 0.00513 + \frac{17.600}{M}$$

Eq. 1036.505-4

Example:

$$C_{rr} = 0.00513 + \frac{17.600}{32499} = 0.0057 \text{ kgN/kgN} = 0.0057 \text{ N/N}$$

(v) Determine the vehicle curb mass, M_{curb} , as follows:

$$M_{\text{curb}} = -0.000007376537 \cdot M^2 + 0.6038432 \cdot M$$

Eq. 1036.505-5

Example:

$$M_{\text{curb}} = -0.000007376537 \cdot 32499^2 + 0.6038432 \cdot 32499 = 11833 \text{ kg}$$

(vi) Determine the linear equivalent mass of rotational moment of inertias, M_{rotating} , as follows:

$$M_{\text{rotating}} = 0.07 \cdot M_{\text{curb}}$$

Eq. 1036.505-6

Example:

$$M_{\text{rotating}} = 0.07 \cdot 11833 = 828.3 \text{ kg}$$

(vii) Select a drive axle ratio, k_a , that represents the worst-case combination of final gear ratio, drive axle ratio, and tire size for CO₂ expected for vehicles in which the hybrid powertrain or hybrid engine will be installed. This is typically the highest numeric axle ratio.

(viii) Select a tire radius, r , that represents the worst-case pair of tire size and drive axle ratio for CO₂ expected for vehicles in which the hybrid powertrain or hybrid engine will be installed. This is typically the smallest tire radius.

(ix) If you are certifying a hybrid powertrain system without the transmission engine, use a default transmission efficiency of 0.95. ~~If you certify with this configuration, you must use 40 CFR 1037.550(a)(3)(ii) to~~ and create the vehicle model along with its default transmission shift strategy as described in 40 CFR 1037.550(a)(3)(ii). Use the transmission parameters defined in Table 1 of § 1036.540 to determine transmission type and gear ratio. For Light HDV and Medium HDVs, use the Light HDV and Medium HDV parameters for ~~the~~ FTP, LLC, and SET duty cycles. For Tractors and Heavy HDVs, use the Tractor and Heavy HDV transient cycle parameters for the FTP and LLC duty cycles and the Tractor and Heavy HDV highway cruise cycle parameters for the SET duty cycle.

~~(x) Select axle efficiency, Eff_{axle} , according to 40 CFR 1037.550.~~

(c) Measure emissions using the SET duty cycle shown in Table 1 of this section to determine whether engines and hybrid powertrains meet the steady-state compression-ignition standards specified in subpart B of this part. Table 1 of this section specifies test settings ~~for engine and hybrid powertrain testing~~, as follows:

(1) The duty cycle for testing engines (including hybrid engines) involves a schedule of normalized engine speed and torque values.

(2) The duty cycle for ~~testing~~ hybrid powertrains ~~testing~~ involves a schedule of vehicle speeds and road grade as follows:

(i) Determine road grade at each point based on the continuous rated power of the hybrid powertrain system, $P_{\text{contrated}}$, in kW determined in § 1036.527, the vehicle speed (A, B, or C) in mi/hr for a given SET mode, $v_{\text{ref[speed]}}$, and the specified road-grade coefficients using the following equation:

$$\text{Roadgrade} = a \cdot P_{\text{contrated}}^3 + b \cdot P_{\text{contrated}}^2 \cdot v_{\text{ref[speed]}} + c \cdot P_{\text{contrated}}^2 + d \cdot v_{\text{ref[speed]}}^2 + e \cdot P_{\text{contrated}} \cdot v_{\text{ref[speed]}} + f \cdot P_{\text{contrated}} + g \cdot v_{\text{ref[speed]}} + h$$

Eq. 1036.505-7

Example for SET mode 3a in Table 1 ~~to of~~ this section:

~~This example is for SET mode 3a in Table 1 to § 1036.505.~~

$$P_{\text{contrated}} = 345.2 \text{ kW}$$

$$v_{\text{refB}} = 59.3 \text{ mi/hr}$$

$$\begin{aligned} \text{Road grade} = & 8.296 \cdot 10^{-9} \cdot 345.2^3 + (-4.752 \cdot 10^{-7}) \cdot 345.2^2 \cdot 59.3 + 1.291 \\ & \cdot 10^{-5} \cdot 345.2^2 + 2.88 \cdot 10^{-4} \cdot 59.3^2 + 4.524 \cdot 10^{-4} \cdot 345.2 \cdot 59.3 \\ & + (-1.802 \cdot 10^{-2}) \cdot 345.2 + (-1.83 \cdot 10^{-1}) \cdot 59.3 + 8.81 = 0.53 \% \end{aligned}$$

(ii) Use the vehicle C speed determined in § 1036.527 ~~and d.~~ Determine ~~the~~ vehicle A and B speeds as follows:

(A) Determine vehicle A speed using the following equation:

$$v_{\text{refA}} = v_{\text{refC}} \cdot \frac{55.0}{75.0}$$

Eq. 1036.505-8

Example:

$$v_{\text{refC}} - v_{\text{refC}} = 68.42 \text{ mi/hr}$$

$$v_{\text{refA}} = 68.4 \cdot \frac{55.0}{75.0} = 50.2 \text{ mi/hr}$$

(B) Determine vehicle B speed using the following equation:

$$v_{\text{refB}} = v_{\text{refC}} \cdot \frac{65.0}{75.0}$$

Eq. 1036.505-9

Example:

$$v_{\text{refB}} = 68.4 \cdot \frac{65.0}{75.0} = 59.3 \text{ mi/hr}$$

(3) Table 1 follows:

Table 1 to of § 1036.505—Supplemental Emission Test ~~Ramped-modal~~ Duty Cycle

SET mode	Engine testing			Hybrid powertrain testing									
	Time in mode (seconds)	Engine speed ^{a,b}	Torque (percent) ^{b,c}	Vehicle speed (mi/hr)	Road-grade coefficients								
					<i>a</i>	<i>b</i>	<i>c</i>	<i>d</i>	<i>e</i>	<i>f</i>	<i>g</i>	<i>h</i>	
1a Steady-state	124	Warm Idle	0	Warm Idle	0	0	0	0	0	0	0	0	0
1b Transition	20	Linear Transition	Linear Transition	Linear Transition	-1.898E-08	-5.895E-07	3.780E-05	4.706E-03	6.550E-04	-2.679E-02	1.027E+00	1.542E+01	
2a Steady-state	196	A	100	<i>v</i> _{refA}	-1.227E-08	-5.504E-07	3.946E-05	1.212E-03	5.289E-04	-3.116E-02	-3.227E-01	1.619E+01	
2b Transition	20	Linear Transition	Linear Transition	Linear Transition	-2.305E-09	-4.873E-07	2.535E-05	8.156E-04	4.730E-04	-2.383E-02	-2.975E-01	1.277E+01	
3a Steady-state	220	B	50	<i>v</i> _{refB}	8.296E-09	-4.752E-07	1.291E-05	2.880E-04	4.524E-04	-1.802E-02	-1.830E-01	8.810E+00	
3b Transition	20	B	Linear Transition	<i>v</i> _{refB}	4.642E-09	-5.143E-07	1.991E-05	3.556E-04	4.873E-04	-2.241E-02	-2.051E-01	1.068E+01	
4a Steady-state	220	B	75	<i>v</i> _{refB}	1.818E-10	-5.229E-07	2.579E-05	5.575E-04	5.006E-04	-2.561E-02	-2.399E-01	1.287E+01	
4b Transition	20	Linear Transition	Linear Transition	Linear Transition	5.842E-10	-4.992E-07	2.244E-05	4.700E-04	4.659E-04	-2.203E-02	-1.761E-01	1.072E+01	
5a Steady-state	268	A	50	<i>v</i> _{refA}	3.973E-09	-4.362E-07	1.365E-05	4.846E-04	4.158E-04	-1.606E-02	-1.908E-01	8.206E+00	
5b Transition	20	A	Linear Transition	<i>v</i> _{refA}	-2.788E-10	-4.226E-07	1.812E-05	6.591E-04	4.158E-04	-1.846E-02	-2.201E-01	1.001E+01	
6a Steady-state	268	A	75	<i>v</i> _{refA}	-4.216E-09	-4.891E-07	2.641E-05	8.796E-04	4.692E-04	-2.348E-02	-2.595E-01	1.226E+01	
6b Transition	20	A	Linear Transition	<i>v</i> _{refA}	3.979E-09	-4.392E-07	1.411E-05	2.079E-04	4.203E-04	-1.658E-02	-1.655E-01	7.705E+00	
7a Steady-state	268	A	25	<i>v</i> _{refA}	1.211E-08	-3.772E-07	6.209E-07	1.202E-04	3.578E-04	-8.420E-03	-1.248E-01	4.189E+00	

7b Transition	20	Linear Transition	Linear Transition	Linear Transition	1.659E-09	-4.954E-07	2.103E-05	4.849E-04	4.776E-04	-2.194E-02	-2.551E-01	1.075E+01
8a Steady-state	196	B	100	v _{refB}	-8.232E-09	-5.707E-07	3.900E-05	8.150E-04	5.477E-04	-3.325E-02	-2.956E-01	1.689E+01
8b Transition	20	B	Linear Transition	v _{refB}	4.286E-09	-5.150E-07	2.070E-05	5.214E-04	4.882E-04	-2.291E-02	-2.271E-01	1.157E+01
9a Steady-state	196	B	25	v _{refB}	1.662E-08	-4.261E-07	-2.705E-07	2.098E-05	4.046E-04	-1.037E-02	-1.263E-01	4.751E+00
9b Transition	20	Linear Transition	Linear Transition	Linear Transition	7.492E-09	-5.451E-07	1.950E-05	2.243E-04	5.114E-04	-2.331E-02	-2.270E-01	1.062E+01
10a Steady-state	28	C	100	v _{refC}	-1.073E-09	-5.904E-07	3.477E-05	5.069E-04	5.647E-04	-3.354E-02	-2.648E-01	1.651E+01
10b Transition	20	C	Linear Transition	v _{refC}	9.957E-09	-5.477E-07	1.826E-05	2.399E-04	5.196E-04	-2.410E-02	-2.010E-01	1.128E+01
11a Steady-state	4	C	25	v _{refC}	1.916E-08	-5.023E-07	3.715E-06	3.634E-05	4.706E-04	-1.539E-02	-1.485E-01	6.827E+00
11b Transition	20	C	Linear Transition	v _{refC}	1.474E-08	-5.176E-07	1.027E-05	1.193E-04	4.911E-04	-1.937E-02	-1.713E-01	8.872E+00
12a Steady-state	4	C	75	v _{refC}	6.167E-09	-5.577E-07	2.354E-05	3.524E-04	5.319E-04	-2.708E-02	-2.253E-01	1.313E+01
12b Transition	20	C	Linear Transition	v _{refC}	1.039E-08	-5.451E-07	1.756E-05	2.257E-04	5.165E-04	-2.366E-02	-1.978E-01	1.106E+01
13a Steady-state	4	C	50	v _{refC}	6.209E-09	-5.292E-07	2.126E-05	3.475E-04	5.132E-04	-2.552E-02	-2.212E-01	1.274E+01
13b Transition	20	Linear Transition	Linear Transition	Linear Transition	4.461E-09	-6.452E-07	1.301E-05	1.420E-03	5.779E-04	-1.564E-02	1.949E-01	7.998E+00
14 Steady-state	144	Warm Idle	0	Warm Idle ⁰	0	0	0	0	0	0	0	0

^aEngine speed terms are defined in 40 CFR part 1065.

^bAdvance from one mode to the next within a 20 second transition phase. During the transition phase, command a linear progression from the settings of the current mode to the settings of the next mode.

^cThe percent torque is relative to maximum torque at the commanded engine speed.

(d) Determine criteria pollutant emissions for plug-in hybrid engines and powertrains as follows:

(1) Precondition the engine or powertrain in charge-sustaining mode. Perform testing as described in this section for hybrid engines and hybrid powertrains in charge-sustaining mode.

(2) Carry out a charge-depleting test as described in paragraph (d)(1) of this section, except as follows:

(i) Fully charge the RESS after preconditioning.

(ii) Operate the hybrid engine or powertrain continuously over repeated SET duty cycles until you reach the end-of-test criterion defined in 40 CFR 1066.501(a)(3).

(iii) Calculate emission results for each SET duty cycle. Figure 1 of this section provides an example of a charge-depleting test sequence where there are two test intervals that contain engine operation.

(3) Report the highest emission result for each criteria pollutant from all tests in paragraphs (d)(1) and (2) of this section, even if those individual results come from different test intervals.

(4) Figure 1 follows:

Figure 1 of § 1036.505—SET charge-depleting criteria pollutant test sequence.

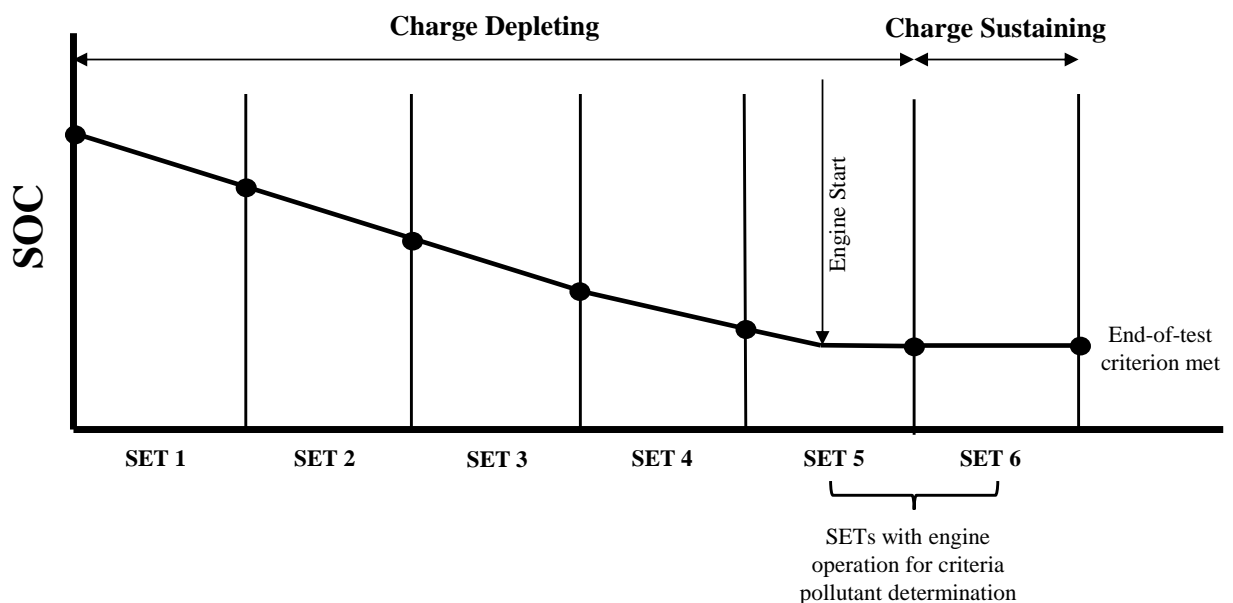

(e) Determine greenhouse gas pollutant emissions for plug-in hybrid engines and powertrains using the emissions results for all the SET test intervals for both charge-depleting and charge-sustaining operation from paragraph (d)(2) of this section. Calculate the utility factor-weighted composite mass of emissions from the charge-depleting and charge-sustaining test results, $e_{UF[emission]comp}$, using the following equation:

$$e_{UF[emission]comp} = \sum_{i=1}^N [e_{[emission][int]CDi} \cdot (UF_{DCDi} - UF_{DCDi-1})] + \sum_{j=1}^M [e_{[emission][int]CSj}] \cdot \frac{(1 - UF_{RCD})}{M}$$

Eq. 1036.505-10

Where:

i = an indexing variable that represents one test interval.

N = total number of charge-depleting test intervals.

$e_{\text{[emission][int]CD}i}$ = total mass of emissions in the charge-depleting portion of the test for each test interval, i , starting from $i = 1$, including the test interval(s) from the transition phase.

$UF_{\text{DCD}i}$ = utility factor fraction at distance $D_{\text{CD}i}$ from Eq. 1036.505-11, as determined by interpolating the approved utility factor curve for each test interval, i , starting from $i = 1$. Let $UF_{\text{DCD}0} = 0$.

j = an indexing variable that represents one test interval.

M = total number of charge-sustaining test intervals.

$e_{\text{[emission][int]CS}j}$ = total mass of emissions in the charge-sustaining portion of the test for each test interval, j , starting from $j = 1$.

UF_{RCD} = utility factor fraction at the full charge-depleting distance, R_{CD} , as determined by interpolating the approved utility factor curve. R_{CD} is the cumulative distance driven over N charge-depleting test intervals.

$$D_{\text{CD}i} = \sum_{k=1}^Q (v_k \cdot \Delta t)$$

Eq. 1036.505-11

Where:

k = an indexing variable that represents one recorded velocity value.

Q = total number of measurements over the test interval.

v = vehicle velocity at each time step, k , starting from $k = 1$. For tests completed under this section, v is the vehicle velocity from the vehicle model in 40 CFR 1037.550. Note that this should include charge-depleting test intervals that start when the engine is not yet operating.

$\Delta t = 1/f_{\text{record}}$

f_{record} = the record rate.

Example using the charge-depletion test in Figure 1 of § 1036.505 for the SET for CO_2 emission determination:

$Q = 24000$

$v_1 = 0$ mi/hr

$v_2 = 0.8$ mi/hr

$v_3 = 1.1$ mi/hr

$f_{\text{record}} = 10$ Hz

$\Delta t = 1/10$ Hz = 0.1 s

$$D_{\text{CD}1} = \sum_{k=1}^{24000} (0 \cdot 0.1 + 0.8 \cdot 0.1 + 1.1 \cdot 0.1 + v_{24000} \cdot \Delta t) = 30.1 \text{ mi}$$

$D_{\text{CD}2} = 30.0$ mi

$D_{\text{CD}3} = 30.1$ mi

$D_{\text{CD}4} = 30.2$ mi

$D_{\text{CD}5} = 30.1$ mi

$N = 5$

$UF_{\text{DCD}1} = 0.11$

$UF_{\text{DCD}2} = 0.23$

$UF_{\text{DCD}3} = 0.34$

$$UF_{DCD4} = 0.45$$

$$UF_{DCD5} = 0.53$$

$$e_{CO2SETCD1} = 0 \text{ g/hp}\cdot\text{hr}$$

$$e_{CO2SETCD2} = 0 \text{ g/hp}\cdot\text{hr}$$

$$e_{CO2SETCD3} = 0 \text{ g/hp}\cdot\text{hr}$$

$$e_{CO2SETCD4} = 0 \text{ g/hp}\cdot\text{hr}$$

$$e_{CO2SETCD5} = 174.4 \text{ g/hp}\cdot\text{hr}$$

$$M = 1$$

$$e_{CO2SETCS} = 428.1 \text{ g/hp}\cdot\text{hr}$$

$$UF_{RCD} = 0.53$$

$$e_{UFCO2comp} = [0 \cdot (0.11 - 0) + 0 \cdot (0.23 - 0.11) + 0 \cdot (0.34 - 0.23) + 0 \cdot (0.45 - 0.34) + 174.4 \cdot (0.53 - 0.45)] + 428.1 \cdot \frac{(1 - 0.53)}{1} = 215.2 \text{ g/hp}\cdot\text{hr}$$

(f) Calculate and evaluate cycle statistics as specified in 40 CFR 1065.514 for nonhybrid engines and 40 CFR 1037.550 for hybrid engines and hybrid powertrains.

(g) Calculate cycle work for powertrain testing using system power, P_{sys} . Determine P_{sys} , using §1036.527(e).

(h) If you certify to the clean idle standard in § 1036.104(b), determine the mean mass emission rate, $\bar{m}_{[emission]}$, in g/hr over the combined warm idle modes 1a and 14 of the SET duty cycle for HC, CO, and PM by calculating the total emission mass $m_{[emission]}$ and dividing by the total time. Note that this requires creating composite emission values from separate samples for CO and PM. These values for $\bar{m}_{[emission]}$ serve as emission standards for testing over the Clean Idle test in §1036.514. (Note: for plug-in hybrid engines and powertrains, use the SET results from the charge-sustaining or charge-depleting tests that have the highest emission values.)

§ 1036.510 ~~Transient testing~~ **Federal Test Procedure.**

(a) Measure emissions using the transient Federal Test Procedure (FTP) as described in this section by testing the engine or hybrid powertrain on a dynamometer with one of the following ~~transient duty cycles~~ to determine whether it engines meets the ~~transient~~ emission standards in subpart B of this part. Operate the engine or hybrid powertrain over one of the following transient duty cycles:

(1) For engines subject to spark-ignition ~~engines standards~~, use the transient duty cycle described in paragraph (a) of appendix B of this part.

(2) For engines subject to compression-ignition ~~engines standards~~, use the transient duty cycle described in paragraph (b) of appendix B of this part.

~~(3) For spark-ignition hybrid powertrains, use the transient duty cycle described in paragraph (a) of appendix B of this part.~~

~~(4) For compression-ignition hybrid powertrains, use the transient duty cycle described in paragraph (b) of appendix B of this part.~~

(b) ~~Perform~~ The following procedures depending on if you are apply differently for testing engines ~~or~~ and hybrid powertrains:

(1) ~~For engine testing,~~ The transient duty cycles for nonhybrid engine testing are based on normalized speed and torque values ~~relative to certain maximum values~~. Denormalize speed as described in 40 CFR 1065.512. Denormalize torque as described in 40 CFR 1065.610(d). Denormalize speed as described in 40 CFR 1065.512.

(2) ~~For Test~~ hybrid engines and hybrid powertrains testing, follow as described in § 1036.505(b)(2) and (3), with the following exceptions:

(i) ~~R to carry out the test except~~ replace $P_{\text{contrated}}$ with P_{rated} , which is the peak rated power determined in § 1036.527;

(ii) ~~keep~~ Keep the transmission in drive for all idle segments after the initial idle segment.

(iii) ~~and for~~ For hybrid engines, select the transmission from Table 1 of § 1036.540, substituting “engine” for “vehicle”.

(iv) For hybrid engines, you may request to change the engine-commanded torque at idle to better represent curb idle transmission torque (CITT).

(v) For plug-in hybrid engines and powertrains, test over the FTP in both charge-sustaining and charge-depleting operation for both criteria and greenhouse gas pollutant determination.

(c) The ~~transient-FTP duty cycle test sequence~~ consists of an initial run through the transient duty cycle from a cold start as described in 40 CFR part 1065, subpart F, followed by a (20 ±1) minute hot soaks with no engine operation, and then a final hot start run through of the same transient duty cycle. Emissions from engine starting is part of ~~the~~ both the cold-start and hot-start test intervals. Calculate the total emission mass of each constituent, m , and the total work, W , over each test interval according to as described in 40 CFR 1065.650. Calculate total work over each test interval for powertrain testing using system power, P_{sys} . Determine P_{sys} using § 1036.527(e). For powertrains with automatic transmissions, account for and include the work produced by the engine from the CITT load. Calculate the official transient emission result from the cold-start and hot-start test intervals using the following equation:

$$\text{Official transient emission result} = \frac{\text{cold start emissions (g)} + 6 \cdot \text{hot start emissions (g)}}{\text{cold start work (hp} \cdot \text{hr)} + 6 \cdot \text{hot start work (hp} \cdot \text{hr)}}$$

Eq. 1036.510-1

(d) Determine criteria pollutant emissions for plug-in hybrid engines and powertrains as follows:

(1) Precondition the engine or powertrain in charge-sustaining mode. Perform testing as described in this section for hybrid engines and hybrid powertrains in charge-sustaining mode.

(2) Carry out a charge-depleting test as described in paragraph (d)(1) of this section, except as follows:

(i) Fully charge the battery after preconditioning.

(ii) Operate the hybrid engine or powertrain over one FTP duty cycle followed by alternating repeats of a 20-minute soak and a hot start test interval until you reach the end-of-test criteria defined in 40 CFR 1066.501.

(iii) Calculate emission results for each successive pair of test intervals. Calculate the emission result by treating the first of the two test intervals as a cold-start test. Figure 1 of § 1036.510 provides an example of a charge-depleting test sequence where there are three test intervals with engine operation for two overlapping FTP duty cycles.

(3) Report the highest emission result for each criteria pollutant from all tests in paragraphs (d)(1) and (2) of this section, even if those individual results come from different test intervals.

(4) Figure 1 follows:

Figure 1 of § 1036.510—FTP charge-depleting criteria pollutant test sequence.

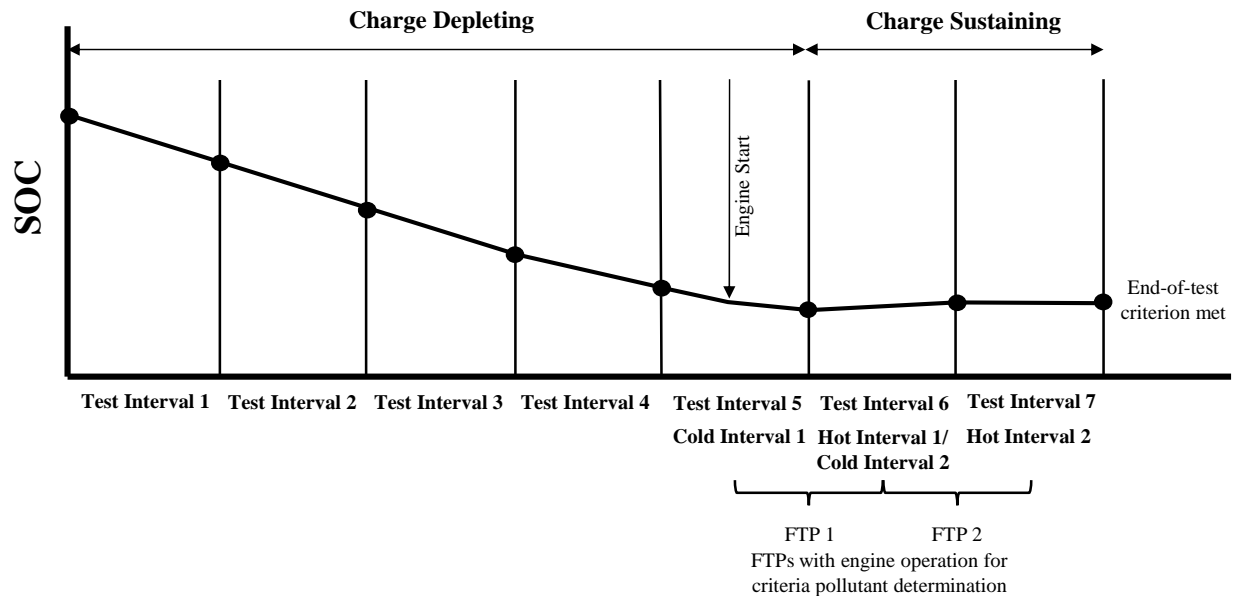

(e) Determine greenhouse gas pollutant emissions for plug-in hybrid engines and powertrains using the emissions results for all the transient duty cycle test intervals described in either paragraph (b) or (c) of appendix B of this part for both charge-depleting and charge-sustaining operation from paragraph (d)(2) of this section. Calculate the utility factor weighted composite mass of emissions from the charge-depleting and charge-sustaining test results, $e_{UF[emission]comp}$, as described in § 1036.505(e), replacing occurrences of “SET” with “transient test interval”. Note this results in composite FTP GHG emission results for plug-in hybrid engines and powertrains without the use of the cold-start and hot-start test interval weighting factors in Eq. 1036.510-1.

(d) Calculate and evaluate cycle statistics and compare with the established criteria as specified in 40 CFR 1065.514 for nonhybrid engines and 40 CFR 1037.550 for hybrid engines and hybrid powertrains to confirm that the test is valid.

(g) If you certify to the clean idle standard in § 1036.104(b), determine the mean mass emission rate, $\bar{m}_{[emission]}$, in g/hr over the idle segments of the FTP duty cycle for HC, CO, and PM by calculating the total emission mass $m_{[emission]}$ and dividing by the total time. Note that this requires creating composite emission values from separate samples for CO and PM. These values for $\bar{m}_{[emission]}$ serve as emission standards for testing over the Clean Idle test in §1036.514. (Note: for plug-in hybrid engines and powertrains, use the FTP results from the charge-sustaining or charge-depleting tests that have the highest emission values.)

§ 1036.512 Low Load Cycle.

(a) Measure emissions using the transient Low Load Cycle (LLC) as described in this section to determine whether engines meet the LLC emission standards in § 1036.104.

(b) The operating profile for the LLC is in paragraph (d) of appendix B of this part. The following procedures apply differently for testing engines and hybrid powertrains:

(1) For engine testing, the duty cycle is based on normalized speed and torque values.

(i) Denormalize speed as described in 40 CFR 1065.512. Denormalize torque as described in 40 CFR 1065.610(d).

- (ii) For idle segments more than 200 seconds, set reference torques to zero instead of CITT. This is to represent shifting the transmission to park or neutral at the start of the idle segment. Change the reference torque to CITT no earlier than 5 seconds before the end of the idle segment. This is to represent shifting the transmission to drive.
- (2) Test hybrid powertrains as described in § 1036.505(b)(2), with the following exceptions:
 - (i) Replace $P_{contrated}$ with P_{rated} , which is the peak rated power determined in § 1036.527.
 - (ii) Keep the transmission in drive for all idle segments 200 seconds or less. For idle segments more than 200 seconds, place the transmission in park or neutral at the start of the idle segment and place the transmission into drive again no earlier than 5 seconds before the first nonzero vehicle speed setpoint.
- (3) For gaseous-fueled engine testing with a single-point fuel injection system, you may apply all the statistical criteria in § 1036.540(d)(3) to validate the LLC.
- (c) Set dynamometer torque demand such that vehicle power represents an accessory load for all idle operation as described in Table 1 of this section for each primary intended service class. Additional provisions related to accessory load apply for the following special cases:
 - (1) For engines with stop-start technology, account for accessory load during engine-off conditions by determining the total engine-off power demand over the test interval and distributing that load over the engine-on portions of the test interval based on calculated average power. You may determine the engine-off time by running practice cycles or through engineering analysis.
 - (2) Apply accessory loads for hybrid powertrain testing that includes the transmission either as a mechanical or electrical load.
 - (3) You may apply the following deviations from specified torque settings for smoother idle (other than idle that includes motoring), or you may develop different procedures for adjusting accessory load at idle consistent with good engineering judgment:
 - (i) Set the reference torque to correspond to the applicable accessory load for all points with normalized speed at or below zero percent and reference torque from zero up to the torque corresponding to the accessory load.
 - (ii) Change the reference torques to correspond to the applicable accessory load for consecutive points with reference torques from zero up to the torque corresponding to the accessory load that immediately precedes or follows idle points.
 - (4) Table 1 follows:

Table 1 of § 1036.512—Accessory Load at Idle

<u>Primary Intended Service Class</u>	<u>Power Representing Accessory Load (kW)</u>
<u>Light HDE</u>	<u>1.5</u>
<u>Medium HDE</u>	<u>2.5</u>
<u>Heavy HDE</u>	<u>3.5</u>

- (d) The transient test sequence consists of preconditioning the engine by running one or two FTPs with each FTP followed by (20 ± 1) minutes with no engine operation and running the LLC. You may start any preconditioning FTP with a hot engine. Perform testing as described in 40 CFR 1065.530 for a test interval that includes engine starting. Calculate the total emission mass of each constituent, m , and the total work, W , as described in 40 CFR 1065.650.
- (e) Determine criteria pollutant and greenhouse gas emissions for plug-in hybrid engines and powertrains as described in § 1036.505(d) and (e), replacing “SET” with “LLC”.

(f) Calculate and evaluate cycle statistics as specified in 40 CFR 1065.514 for nonhybrid engines and 40 CFR 1037.550 for hybrid engines and hybrid powertrains.

§ 1036.514 Clean Idle test.

Measure emissions using the procedures described in this section to determine whether engines and hybrid powertrains meet the clean idle emission standards in § 1036.104(b). For plug-in hybrid engines and powertrains, perform the test with the hybrid function disabled.

(a) The clean idle test consists of two separate test intervals as follows:

(1) Mode 1 consists of engine operation with a speed setpoint at your recommended warm idle speed. Set the dynamometer torque demand corresponding to vehicle power requirements at your recommended warm idle speed that represent in-use operation.

(2) Mode 2 consists of engine operation with a speed setpoint at 1100 r/min. Set the dynamometer torque demand to account for the sum of the following power loads:

(i) Determine power requirements for idling at 1100 r/min.

(ii) Apply a power demand of 2 kW to account for appliances and accessories the vehicle operator may use during rest periods.

(3) Determine torque demand for testing under this paragraph (a) based on an accessory load that includes the engine cooling fan, alternator, coolant pump, air compressor, engine oil and fuel pumps, and any other engine accessory that operates at the specific test condition. Also include the accessory load from the air conditioning compressor operating at full capacity for Mode 2. Do not include any other load for air conditioning or other cab or vehicle accessories except as specified.

(b) Perform the Clean Idle test as follows:

(1) Warm up the engine by operating it over the FTP or SET duty cycle, or by operating it at any speed above peak-torque speed and at (65 to 85) % of maximum mapped power. The warm-up is complete when the engine thermostat controls engine temperature or when the engine coolant's temperature is within 2 % of its mean value for at least 2 minutes.

(2) Start operating the engine in Mode 1 as soon as practical after the engine warm-up is complete.

(3) Start sampling emissions 10 minutes after reaching the speed and torque setpoints and continue emission sampling and engine operation at those setpoints. Stop emission sampling after 1200 seconds to complete the test interval.

(4) Linearly ramp the speed and torque setpoints over 5 seconds to start operating the engine in Mode 2. Sample emissions during Mode 2 as described in paragraph (b)(3) of this section.

(c) Verify that the test speed stays within ± 50 r/min of the speed setpoint throughout the test. The torque tolerance is ± 2 percent of the maximum mapped torque at the test speed. Verify that measured torque meets the torque tolerance relative to the torque setpoint throughout the test.

(d) Calculate the mean mass emission rate of NO_x, HC, CO, and PM, $\bar{m}_{[emission]}$ over each test interval by calculating the total emission mass $m_{[emission]}$ and dividing by the total time.

§ 1036.515 Test procedures for off-cycle testing.

(a) General. This section describes the measurement and calculation procedures to perform field testing under subpart E of this part. Use good engineering judgment if you use these procedures to simulate vehicle operation in the laboratory.

(b) Emission measurement. Set up the vehicle for testing with a portable emissions measurement system (PEMS) as specified in 40 CFR part 1065, subpart J. Measure emissions over one or

more shift-days as specified in subpart E of this part. Collect data using moving average windows as follows:

(1) Start the engine at the beginning of the shift-day only after confirming that engine coolant temperature is at or below 30 °C and that all measurement systems are activated as described in 40 CFR 1065.935(c)(3). Start emission sampling just before starting the engine.

(2) Determine the test interval as follows:

(i) For Light HDE, Medium HDE, and Heavy HDE, establish a test interval for every 300 second moving average window until key-off. Create each new window starting 1 second after the start of the previous window. Note that most 1 Hz data points will be included in 300 windows.

(ii) For Spark-ignition HDE, your test interval is the entire shift-day except for data excluded under paragraph (c) of this section.

(3) For Light HDE, Medium HDE, and Heavy HDE, create windows as follows if you exclude data under paragraph (c) of this section:

(i) For excluded blocks of data that are less than 300 seconds long, create 300 second moving average windows that include operation before and after the excluded portion. The resulting windows might include multiple interruptions less than 300 seconds long that may total more than 300 seconds.

(ii) For excluded blocks of data that are 300 seconds or longer, discontinue windows at the start of the excluded portion. Create new 300 second moving average windows following the excluded portion, like at the start of the shift-day.

(c) Exclusions. Exclude the following shift-day data:

(1) Data collected during the PEMS zero and span drift checks or zero and span calibrations. Emissions analyzers are not available to measure emissions during that time and these checks/calibrations are needed to ensure the robustness of the data.

(2) Data collected where the engine is off, including engine off due to automated start/stop.

(3) Data collected during infrequent regeneration events. The data collected for the test order may not collect enough operation during the infrequent regeneration to properly weight the emissions rates during an infrequent regeneration event with emissions that occur without an infrequent regeneration event

(4) Data collected where the instantaneous ambient air temperature is below -7 °C or above the value in degrees Celsius calculated using Eq. 1036.515-1. Colder temperatures can significantly inhibit the engine's ability to maintain aftertreatment temperature above the minimum operating temperature of the SCR catalyst while high temperature conditions at altitude can adversely affect (limit) the mass airflow through the engine, which can affect the engines ability to reduce engine out NO_x through the use of EGR. In addition to affecting EGR, the air-fuel ratio of the engine can decrease under high load, which can increase exhaust temperatures above the condition where the SCR catalyst is most efficient at reducing NO_x.

$$T_{\text{invalid}} = -0.0014 \cdot h + 37.778$$

Eq. 1036.515-1

Where:

h = instantaneous altitude in feet above sea level (h is negative for altitudes below sea-level).

(5) Data collected where the altitude more than 5,500 feet above sea level for the same reasons given for the high temperature at altitude exclusion in paragraph (c)(4) of this section.

(6) If your engine family includes engines with one or more approved AECs for emergency vehicle applications under § 1036.115(h)(1)(iv), any data where these AECs are active because the engines are allowed to exceed the emission standards when these AECs are active. Do not exclude data for any other AECs.

(d) Mean mass percent of CO₂ from normalized CO₂ rate. For Light HDE, Medium HDE, and Heavy HDE, determine the mean mass percent of CO₂ of a window, \bar{w}_{CO_2win} , using the following equation:

$$\bar{w}_{CO_2win} = \frac{\bar{m}_{CO_2win}}{\dot{m}_{CO_2max}}$$

Eq. 1036.515-2

Where:

\bar{m}_{CO_2win} = mean mass rate of CO₂ over the valid window.

$\dot{m}_{CO_2max} = e_{CO_2FTPFL} \cdot P_{max}$

e_{CO_2FTPFL} = the engine's FTP FCL CO₂ emission value.

P_{max} = the engine family's maximum power determined according to the torque mapping test procedure defined in 40 CFR 1065.510.

Example:

$$\bar{m}_{CO_2win} = 13.16 \text{ g/s} = 47368 \text{ g/hr}$$

$$e_{CO_2FTPFL} = 428.2 \text{ g/hp}\cdot\text{hr}$$

$$P_{max} = 406.5 \text{ hp}$$

$$\dot{m}_{CO_2max} = 428.2 \cdot 406.5 = 174063 \text{ g/hr}$$

$$\bar{w}_{CO_2win} = \frac{47368}{174063} = 0.272 = 27.2 \%$$

(e) Binning. For Light HDE, Medium HDE, and Heavy HDE, segregate test results from each 300 second window over the shift-day based on its mean mass percent of CO₂ into one of the following bins:

Table 1 of §1036.515—Criteria for Off-Cycle Bin Types

Bin	Mean mass percent of CO₂
<u>Idle</u>	$\bar{w}_{CO_2win} < 6 \%$
<u>Low load</u>	$6 \% < \bar{w}_{CO_2win} < 20 \%$
<u>Medium/high load</u>	$\bar{w}_{CO_2win} > 20 \%$

(f) Window emission values. For Light HDE, Medium HDE, and Heavy HDE, determine the emission mass for a given window, $m_{[emission]win}$, for CO₂ and other measured emissions using the following equation:

$$m_{[emission]win} = \sum_{i=1}^N \dot{m}_{[emission]i} \cdot \Delta t$$

Eq. 1036.515-3

Where:

i = an indexing variable that represents one recorded emission value.

N = total number of measurements in the window.

$\dot{m}_{[\text{emission}]}$ = mass emission rate at a point in time within a given window.

$\Delta t = 1/f_{\text{record}}$

f_{record} = the record rate.

Example:

$N = 300$

$\dot{m}_{\text{NOx1}} = 0.0179$ g/s

$\dot{m}_{\text{NOx2}} = 0.0181$ g/s

$f_{\text{record}} = 1$ Hz

$\Delta t = 1/1$ Hz = 1 s

$m_{\text{NOxwin}} = (0.0179 + 0.0181 + \dots + \dot{m}_{\text{NOx300}}) \cdot 1 = 5.46$ g

(g) Bin emission values. For Light HDE, Medium HDE, and Heavy HDE, determine the emission value for each bin, which may include measurement windows from multiple vehicles.

(1) Determine the sum of the NO_x emissions from each window for the idle bin, e_{NOxidle} , using the following equation:

$$e_{\text{NOxidle}} = \frac{\sum_{i=1}^N m_{\text{NOxidlewin}i}}{\sum_{i=1}^N \Delta t_i}$$

Eq. 1036.515-4

Where:

i = an indexing variable that represents one window.

N = total number of windows in the bin.

$m_{\text{NOxidlewin}}$ = total mass of NO_x emissions for a given window as determined in paragraph (f) of this section.

$\Delta t_i = t_i - t_{i-1}$

Example:

$N = 10114$

$m_{\text{NOxidlewin1}} = 0.021$ g

$m_{\text{NOxidlewin2}} = 0.025$ g

$\Delta t_1 = 1$

$\Delta t_2 = 1$

$$e_{\text{NOxidle}} = \frac{(0.021 + 0.025 + \dots + m_{\text{NOxmediumhighloadwin10114}})}{(1 + 1 \dots + \Delta t_{10114})} \dots + \Delta t_{10114} = 0.000285 \text{ g/s}$$
$$= 1.026 \text{ g/hr}$$

(2) Determine the sum of mass emissions from each window over the sum of CO₂ emissions from each window for the low load and medium high load bins, $e_{\text{sos[emission][bin]}}$, for each measured pollutant using the following equation:

$$e_{\text{sos[emission][bin]}} = \frac{\sum_{i=1}^N m_{[\text{emission}][\text{bin}]wini}}{\sum_{i=1}^N m_{\text{CO2[bin]wini}}} \cdot e_{\text{CO2FTPFL}}$$

Eq. 1036.515-5

Where:

i = an indexing variable that represents mass emissions from one window.

N = total number of windows in the bin.

$m_{[\text{emission}][\text{bin}]\text{win}}$ = sum of mass for each emission for a given window and bin as determined in paragraph (f) of this section.

$m_{\text{CO}_2[\text{bin}]\text{win}}$ = sum of mass for CO₂ for a given window and bin as determined in paragraph (f) of this section.

$e_{\text{CO}_2\text{FTPFCCL}}$ = the FCL value for CO₂ emissions over the FTP duty cycle identified in the engine family's application for certification.

Example:

$N = 15439$

$m_{\text{NO}_x\text{mediumhighloadwin1}} = 0.546 \text{ g}$

$m_{\text{NO}_x\text{mediumhighloadwin2}} = 0.549 \text{ g}$

$m_{\text{CO}_2\text{mediumhighloadwin1}} = 10950.2 \text{ g}$

$m_{\text{CO}_2\text{mediumhighloadwin2}} = 10961.3 \text{ g}$

$e_{\text{CO}_2\text{FTPFCCL}} = 428.1 \text{ g/hp}\cdot\text{hr}$

$$e_{\text{SO}_x\text{NO}_x\text{mediumhighload}} = \frac{(0.546 + 0.549 + \dots + m_{\text{NO}_x\text{mediumhighloadwin15439}})}{(10950.2 + 10961.3 \dots + m_{\text{CO}_2\text{mediumhighloadwin15439}})} \cdot 428.1$$
$$= 0.026 \text{ g/hp}\cdot\text{hr}$$

(h) Shift-day emission values for spark-ignition engines. For spark-ignition engines, determine the shift-day emission values as follows:

(1) Determine the emission mass for a shift-day, $m_{[\text{emission}]\text{shift}}$, for each measured pollutant and CO₂ using the following equation:

$$m_{[\text{emission}]\text{shift}} = \sum_{i=1}^N \dot{m}_{[\text{emission}]i} \cdot \Delta t$$

Eq. 1036.515-6

Where:

i = an indexing variable that represents one recorded emission value.

N = total number of measurements in the shift-day.

$\dot{m}_{[\text{emission}]}$ = mass emission rate at a point in time within a given shift-day.

$\Delta t = 1/f_{\text{record}}$

f_{record} = the record rate.

Example:

$N = 24543$

$\dot{m}_{\text{NO}_x1} = 0.0187 \text{ g/s}$

$\dot{m}_{\text{NO}_x2} = 0.0191 \text{ g/s}$

$f_{\text{record}} = 1 \text{ Hz}$

$\Delta t = 1/1 \text{ Hz} = 1 \text{ s}$

$m_{\text{NO}_x\text{shift}} = (0.0187 + 0.0191 + \dots + \dot{m}_{\text{NO}_x24543}) \cdot 1 = 1.337 \text{ g}$

(2) Determine the sum of mass emissions from the shift day over the sum of CO₂ emissions from the shift day, $e_{\text{SO}_x[\text{emission}]\text{shift}}$, for each measured pollutant using the following equation:

$$e_{\text{sos[emission]shift}} = \frac{m_{\text{[emission]shift}}}{m_{\text{CO2shift}}} \cdot e_{\text{CO2FTPFL}}$$

Eq. 1036.515-7

Where:

$m_{\text{[emission]shift}}$ = sum of mass for each emission for the shift day as determined in paragraph (h)(1) of this section.

m_{CO2shift} = sum of mass for CO₂ for the shift day as determined in paragraph (j)(1) of this section.

e_{CO2FTPFL} = the FCL value for CO₂ emissions over the FTP duty cycle identified in the engine family's application for certification.

Example:

$$m_{\text{NOxshift}} = 1.337 \text{ g}$$

$$m_{\text{CO2shift}} = 18778 \text{ g}$$

$$e_{\text{CO2 FTPFL}} = 505.1 \text{ g/hp}\cdot\text{hr}$$

$$e_{\text{sosNOxmediumhighload}} = \frac{1.337}{18778} \cdot 505.1 = 0.035 \text{ g/hp}\cdot\text{hr}$$

§ 1036.520 Test procedures to verify deterioration factors.

Sections 1036.240 through 1036.246 describe certification procedures to determine, verify, and apply deterioration factors. This section describes the measurement procedures for verifying deterioration factors using PEMS or onboard NO_x sensors with in-use vehicles.

(a) Use PEMS or onboard NO_x sensors to collect 1 Hz data throughout a shift-day of driving. Collect all the data elements needed to determine brake-specific emissions. Calculate emission results using moving average windows as described in § 1036.515.

(b) Collect data as needed to perform the calculations specified in paragraph (a) of this section and to submit the test report specified in § 1036.246(f).

§ 1036.522 Infrequently regenerating aftertreatment devices.

For engines using aftertreatment technology with infrequent regeneration events that may occur during testing, take one of the following approaches to account for the emission impact of regeneration on criteria pollutant and greenhouse gas emissions:

(a) You may use the calculation methodology described in 40 CFR 1065.680 to adjust measured emission results. Do this by developing an upward adjustment factor and a downward adjustment factor for each pollutant based on measured emission data and observed regeneration frequency as follows:

(1) Adjustment factors should generally apply to an entire engine family, but you may develop separate adjustment factors for different configurations within an engine family.

Use the adjustment factors from this section for all testing for the engine family.

(2) You may use carryover data to establish adjustment factors for an engine family as described in § 1036.235, consistent with good engineering judgment.

(3) Identify the value of $F_{\text{[cycle]}}$ in each application for the certification for which it applies.

(4) Calculate separate adjustment factors for each required duty cycle.

(b) You may ask us to approve an alternate methodology to account for regeneration events. We will generally limit approval to cases where your engines use aftertreatment technology with extremely infrequent regeneration and you are unable to apply the provisions of this section.

(c) You may choose to make no adjustments to measured emission results if you determine that regeneration does not significantly affect emission levels for an engine family (or configuration) or if it is not practical to identify when regeneration occurs. You may omit adjustment factors under this paragraph (c) for N₂O, CH₄, or other individual pollutants under this paragraph (c) as appropriate. If you choose not to make adjustments under paragraph (a) or (b) of this section, your engines must meet emission standards for all testing, without regard to regeneration.

~~§ 1036.525 Hybrid engines.~~

~~(a) For model years 2014 through 2020, if your engine system includes features that recover and store energy during engine motoring operation, test the engine as described in paragraph (d) of this section. For purposes of this section, features that recover energy between the engine and transmission are considered related to engine motoring.~~

~~(b) If you produce a hybrid engine designed with power take-off capability and sell the engine coupled with a transmission, you may calculate a reduction in CO₂ emissions resulting from the power take-off operation as described in 40 CFR 1037.540. Quantify the CO₂ reduction for your engines using the vehicle-based procedures, consistent with good engineering judgment.~~

~~(c) For engines that include electric hybrid systems, test the engine with the hybrid electric motor, the rechargeable energy storage system (RESS), and the power electronics between the hybrid electric motor and the RESS. You may ask us to modify the provisions of this section for testing engines with other kinds of hybrid systems.~~

~~(d) Measure emissions using the same procedures that apply for testing non-hybrid engines under this part, except as specified in this part and 40 CFR part 1065. For SET testing, deactivate the hybrid features unless we specify otherwise. The following provisions apply for testing hybrid engines:~~

~~(1) *Engine mapping.* Map the engine as specified in 40 CFR 1065.510. This requires separate torque maps for the engine with and without the hybrid features active. For transient testing, denormalize the duty cycle using the map generated with the hybrid feature active. For steady-state testing, denormalize the duty cycle using the map generated without the hybrid feature.~~

~~(2) *Engine shutdown during testing.* If you will configure production engines to shut down automatically during idle operation, you may let the engine shut down during the idle portions of the duty cycle.~~

~~(3) *Work calculation.* Calculate positive and negative work done over the cycle according to 40 CFR 1065.650(d), except that you must set power to zero to calculate negative work done for any period over the cycle where the engine produces net positive power or where the negative power is solely from the engine and not the hybrid system.~~

~~(4) *Limits on braking energy.* Calculate brake energy fraction, x_b , as follows:~~

~~(i) Calculate x_b as the integrated negative work over the cycle divided by the integrated positive work over the cycle according to Eq. 1036.525-1. Calculate the brake energy limit for the engine, x_{bl} , according to Eq. 1036.525-2. If x_b is less than or equal to x_{bl} , use the integrated positive work for your emission calculations. If x_b is greater than x_{bl} , use Eq. 1036.525-3 to calculate an adjusted value for cycle work, W_{cycle} , and use W_{cycle} as the work value for calculating emission results. You may set an instantaneous brake target that will prevent x_b from being larger than x_{bl} to avoid the need to subtract extra brake work from positive work.~~

$$x_b = \frac{|W_{\text{neg}}|}{W_{\text{pos}}}$$

Eq. 1036.525-1

Where:

W_{neg} = the negative work over the cycle.

W_{pos} = the positive work over the cycle.

$$x_{\text{bl}} = 4.158 \cdot 10^{-4} \cdot P_{\text{max}}$$

Eq. 1036.525-2

Where:

P_{max} = the maximum power of the engine with the hybrid system engaged, in kW.

$$W_{\text{cycle}} = W_{\text{pos}} - (|W_{\text{neg}}| - x_{\text{bl}} \cdot W_{\text{pos}})$$

Eq. 1036.525-3

Where:

W_{cycle} = cycle work when x_b is greater than x_{bl} .

Example:

$W_{\text{neg}} = 4.69 \text{ kW-hr}$

$W_{\text{pos}} = 14.67 \text{ kW-hr}$

$P_{\text{max}} = 223 \text{ kW}$

$$x_b = \frac{4.69}{14.67} = 0.31970$$

$$x_{\text{bl}} = 4.158 \cdot 10^{-4} \cdot 223 + 0.2247 = 0.317423$$

since $x_b > x_{\text{bl}}$;

$$W_{\text{cycle}} = 14.67 - (4.69 - 0.317423 \cdot 14.67) = 14.6365 \text{ kW-hr}$$

(ii) Convert from g/kW-hr to g/hp-hr as the final step in calculating emission results.

(5) *State of charge.* Correct for the net energy change of the energy storage device as described in 40 CFR 1066.501.

§ 1036.527 Powertrain system rated power determination.

This section describes how to determine the peak and continuous rated power of conventional and hybrid powertrain systems and the vehicle speed for carrying out testing according to §§ 1036.505 and 1036.510 and 40 CFR 1037.550.

(a) Set up the powertrain according to 40 CFR 1037.550, but use the vehicle parameters in § 1036.505(b)(2), except replace $P_{\text{contrated}}$ with the manufacturer declared system peak power and use applicable automatic transmission for the engine. Note that if you repeat the system rated power determination as described in paragraph (f)(4) of this section, use the measured system peak power in place of $P_{\text{contrated}}$.

(b) Prior to the start of each test interval verify the following:

(1) The state-of-charge of the rechargeable energy storage system (RESS) is ≥ 90 % of the operating range between the minimum and maximum RESS energy levels specified by the manufacturer.

(2) The conditions of all hybrid system components are within their normal operating range as declared by the manufacturer.

(3) RESS restrictions (e.g., power limiting, thermal limits, etc.) are not active.

(c) Carry out the test as follows:

(1) Warm up the powertrain by operating it. We recommend operating the powertrain at any vehicle speed and road grade that achieves approximately 75 % of its expected maximum power. Continue the warm-up until the engine coolant, block, or head absolute temperature is within ± 2 % of its mean value for at least 2 min or until the engine thermostat controls engine temperature.

(2) Once warmup is complete, bring the vehicle speed to 0 mi/hr and start the test by operating the powertrain keying on the powertrain and letting it sit at 0 mi/hr for 50 seconds.

(3) Set maximum driver demand for a full load acceleration at 6 % road grade starting at an initial vehicle speed of 0 mi/hr.

(4) 268 seconds after the initiation of paragraph (c)(3) of this section, linearly ramp the grade from 6 % to 0 % over 300 seconds. Stop the test after the vehicle speed has stopped increasing above the maximum value observed during the test.

(d) Record the powertrain system angular speed and torque values measured at the dynamometer at 100 Hz and use these in conjunction with the vehicle model to calculate $P_{\text{sys,vehicle}}$.

(e) Calculate the system power, P_{sys} , for each data point as follows:

(1) For testing with the speed and torque measurements at the transmission input shaft, $P_{\text{sys}i}$ is equal to the calculated vehicle system ~~peak~~ power, $P_{\text{sys}i,\text{vehicle}}$, determined in paragraphs (c) through (d) of this section.

(2) For testing with the speed and torque measurements at the axle input shaft or the wheel hubs, determine P_{sys} for each data point using the following equation:

$$P_{\text{sys}i} = \frac{P_{\text{sys}i,\text{vehicle}}}{\epsilon_{\text{trans}} \cdot \epsilon_{\text{axle}}}$$

Eq. 1036.527-1

Where:

$P_{\text{sys}i,\text{vehicle}}$ = the calculated vehicle system ~~peak~~ power for each data point.

ϵ_{trans} = the default transmission efficiency = 0.95.

ϵ_{axle} = the default axle efficiency. Set this value = 1 for speed and torque measurement at the axle input shaft or = 0.955 at the wheel hubs.

Example:

$$P_{\text{sys,vehicle}} = 317.6 \text{ kW}$$

$$P_{\text{sys}} = \frac{317.6}{0.95 \cdot 0.955} = 350.1 \text{ kW}$$

(f) The system peak rated power, P_{rated} , is the highest calculated P_{sys} where the coefficient of variation (COV) < 2 %. The COV is determined as follows:

(1) Calculate the standard deviation, $\sigma(t)$.

$$\sigma(t) = \sqrt{\frac{1}{N} \cdot \sum_{i=1}^N (P_{\text{sys}i} - \bar{P}_{\text{sys}\#}(t))^2}$$

Eq. 1036.527-2

Where:

N = the number of measurement intervals = 20.

P_{sysi} = the N samples of P_{sys} in the 100 Hz signal previously used to calculate the respective $\bar{P}_{sys}(t)$ values at the time step t .

$\bar{P}_{\#sys}(t)$ = the power vector from the results of each test run that is determined by a moving averaging of 20 consecutive samples of P_{sys} in the 100 Hz that converts $P_{sys\#}(t)$ to a 5 Hz signal.

(2) The resulting 5 Hz power and covariance signals are used to determine system rated power.

(3) The coefficient of variation $COV(t)$ shall be calculated as the ratio of the standard deviation, $\sigma(t)$, to the mean value of power, $\bar{P}_{sys\#}(t)$, for each time step t .

$$COV(t) = \frac{\sigma(t)}{\bar{P}_{sys\#}(t)}$$

Eq. 1036.527-3

(4) If the determined system peak rated power is not within $\pm 3\%$ of the system peak rated power as declared by the manufacturer, you must repeat the procedure in paragraphs (a) through (f)(3) of this section using the measured system peak rated power determined in paragraph (f) of this section instead of the manufacturer declared value. The result from this repeat is the final determined system peak rated power.

(5) If the determined system peak rated power is within $\pm 3\%$ of the system peak rated power as declared by the manufacturer, the declared system peak rated power shall be used.

(g) Determine continuous rated power as follows:

(1) For conventional powertrains, $P_{contrated}$ equals P_{rated} .

(2) For hybrid powertrains, continuous rated power, $P_{contrated}$, is the maximum measured power from the data collected in paragraph (c)(3) of this section that meets the requirements in paragraph (f) of this section.

(h) Vehicle C speed, v_{refC} , is determined as follows:

(1) For powertrains where P_{sys} is greater than $0.98 \cdot P_{contrated}$ in top gear at more than one vehicle speed, v_{refC} is the average of the minimum and maximum vehicle speeds from the data collected in paragraph (c)(4) of this section that meets the requirements in paragraph (f) of this section.

(2) For powertrains where P_{sys} is not greater than $0.98 \cdot P_{contrated}$ in top gear at more than one vehicle speed, v_{refC} is the maximum vehicle speed from the data collected in paragraph (c)(4) of this section that meets the requirements in paragraph (f) of this section where P_{sys} is greater than $0.98 \cdot P_{contrated}$.

§ 1036.530 Calculating greenhouse gas emission rates.

This section describes how to calculate official emission results for CO₂, CH₄, and N₂O.

(a) Calculate brake-specific emission rates for each applicable duty cycle as specified in 40 CFR 1065.650. Apply infrequent regeneration adjustment factors as described in §1036.522 to your CO₂ emission results for each duty cycle as described in 40 CFR 86.004-28 starting in model year 2021. You may optionally apply infrequent regeneration adjustment factors for CH₄ and N₂O.

(b) Adjust CO₂ emission rates calculated under paragraph (a) of this section for measured test fuel properties as specified in this paragraph (b). This adjustment is intended to make official emission results independent of differences in test fuels within a fuel type. Use good engineering

judgment to develop and apply testing protocols to minimize the impact of variations in test fuels.

(1) Determine your test fuel's mass-specific net energy content, $E_{\text{mfuelmeas}}$, also known as lower heating value, in MJ/kg, expressed to at least three decimal places. Determine $E_{\text{mfuelmeas}}$ as follows:

(i) For liquid fuels, determine $E_{\text{mfuelmeas}}$ according to ASTM D4809 (incorporated by reference in § 1036.810). Have the sample analyzed by at least three different labs and determine the final value of your test fuel's $E_{\text{mfuelmeas}}$ as the median all of the lab results you obtained. If you have results from three different labs, we recommend you screen them to determine if additional observations are needed. To perform this screening, determine the absolute value of the difference between each lab result and the average of the other two lab results. If the largest of these three resulting absolute value differences is greater than 0.297 MJ/kg, we recommend you obtain additional results prior to determining the final value of $E_{\text{mfuelmeas}}$.

(ii) For gaseous fuels, determine $E_{\text{mfuelmeas}}$ according to ASTM D3588 (incorporated by reference in § 1036.810).

(2) Determine your test fuel's carbon mass fraction, w_C , as described in 40 CFR 1065.655(d), expressed to at least three decimal places; however, you must measure fuel properties rather than using the default values specified in Table 1 of 40 CFR 1065.655.

(i) For liquid fuels, have the sample analyzed by at least three different labs and determine the final value of your test fuel's w_C as the median of all of the lab results you obtained. If you have results from three different labs, we recommend you screen them to determine if additional observations are needed. To perform this screening, determine the absolute value of the difference between each lab result and the average of the other two lab results. If the largest of these three resulting absolute value differences is greater than 1.56 percent carbon, we recommend you obtain additional results prior to determining the final value of w_C .

(ii) For gaseous fuels, have the sample analyzed by a single lab and use that result as your test fuel's w_C .

(3) If, over a period of time, you receive multiple fuel deliveries from a single stock batch of test fuel, you may use constant values for mass-specific energy content and carbon mass fraction, consistent with good engineering judgment. To use [these constant values](#)~~this paragraph (b)(3)~~, you must demonstrate that every subsequent delivery comes from the same stock batch and that the fuel has not been contaminated.

(4) Correct measured CO₂ emission rates as follows:

$$e_{\text{CO2cor}} = e_{\text{CO2}} \cdot \frac{E_{\text{mfuelmeas}}}{E_{\text{mfuelCref}} \cdot w_{\text{Cmeas}}}$$

Eq. 1036.530-1

Where:

e_{CO2} = the calculated CO₂ emission result.

$E_{\text{mfuelmeas}}$ = the mass-specific net energy content of the test fuel as determined in paragraph (b)(1) of this section. Note that dividing this value by w_{Cmeas} (as is done in this equation) equates to a carbon-specific net energy content having the same units as $E_{\text{mfuelCref}}$.

$E_{\text{mfuelCref}}$ = the reference value of carbon-mass-specific net energy content for the appropriate fuel type, as determined in Table 1 of this section.

$w_{C_{meas}}$ = carbon mass fraction of the test fuel (or mixture of test fuels) as determined in paragraph (b)(2) of this section.

Example:

$$e_{CO_2} = 630.0 \text{ g/hp}\cdot\text{hr}$$

$$E_{mfuel_{meas}} = 42.528 \text{ MJ/kg}$$

$$E_{mfuel_{Cref}} = 49.3112 \text{ MJ/kgC}$$

$$w_{C_{meas}} = 0.870$$

$$e_{CO_2_{cor}} = 630.0 \cdot \frac{42.528}{49.3112 \cdot 0.870}$$

$$e_{CO_2_{cor}} = 624.5 \text{ g/hp}\cdot\text{hr}$$

Table 1 ~~to of~~ § 1036.530—Reference Fuel Properties

Fuel type ^a	Reference fuel carbon-mass-specific net energy content, $E_{mfuel_{Cref}}$, (MJ/kgC) ^b	Reference fuel carbon mass fraction, w_{Cref} ^b
Diesel fuel	49.3112	0.874
Gasoline	50.4742	0.846
Natural Gas	66.2910	0.750
LPG	56.5218	0.820
Dimethyl Ether	55.3886	0.521
High-level ethanol-gasoline blends	50.3211	0.576

^aFor fuels that are not listed, you must ask us to approve reference fuel properties.

^bFor multi-fuel streams, such as natural gas with diesel fuel pilot injection, use good engineering judgment to determine blended values for $E_{mfuel_{Cref}}$ and w_{Cref} using the values in this table.

(c) Your official emission result for each pollutant equals your calculated brake-specific emission rate multiplied by all applicable adjustment factors, other than the deterioration factor.

§ 1036.535 Determining steady-state engine fuel maps and fuel consumption at idle.

~~This~~ The procedures in this section describes how to determine an engine’s steady-state fuel map and fuel consumption at idle for model year 2021 and later vehicles; these procedures apply as described in § 1036.503. Vehicle manufacturers may need these values to demonstrate compliance with emission standards under 40 CFR part 1037-~~as described in § 1036.510~~.

(a) *General test provisions.* Perform fuel mapping using the procedure described in paragraph (b) of this section to establish measured fuel-consumption rates at a range of engine speed and load settings. Measure fuel consumption at idle using the procedure described in paragraph (c) of this section. Paragraph (d) of this section describes how to apply the steady-state mapping from paragraph (b) of this section for the special case of ~~If you perform~~ cycle-average mapping for highway cruise cycles as described in § 1036.540, ~~omit mapping under paragraph (b) of the section and instead perform mapping as described in paragraph (d) of this section~~. Use these measured fuel-consumption values to declare fuel-consumption rates for certification as described in paragraph (e) of this section.

(1) Map the engine's torque curve and declare engine idle speed as described in § 1036.503(c)(1) and (3), ~~and p~~ Perform emission measurements as described in 40 CFR 1065.501 and 1065.530 for discrete-mode steady-state testing. This section uses engine parameters and variables that are consistent with 40 CFR part 1065.

(2) Measure NO_x emissions as described in paragraph (f) of this section ~~for each specified sampling period in g/s. You may perform these measurements using a NO_x emission-measurement system that meets the requirements of 40 CFR part 1065, subpart J.~~ Include these measured NO_x values any time you report to us your fuel consumption values from testing under this section. ~~If a system malfunction prevents you from measuring NO_x emissions during a test under this section but the test otherwise gives valid results, you may consider this a valid test and omit the NO_x emission measurements; however, we may require you to repeat the test if we determine that you inappropriately voided the test with respect to NO_x emission measurement.~~

(3) You may use shared data across engine configurations to the extent that the fuel-consumption rates remain valid.

(4) The provisions related to carbon balance error verification in § 1036.543 apply for all testing in this section. These procedures are optional, but we will perform carbon balance error verification for all testing under this section.

(5) Correct fuel mass flow rate to a mass-specific net energy content of a reference fuel as described in paragraph (e) of this section.

(b) *Steady-state fuel mapping.* Determine steady-state fuel-consumption rates for each engine configuration over a series of ~~steady-state engine operating points consisting of pairs of paired engine~~ speed and torque setpoints as described in this paragraph (b). ~~You may use shared data across an engine platform to the extent that the fuel consumption rates remain valid.~~ For example, if you test a high-output (parent) configuration and create a different (child) configuration that uses the same fueling strategy but limits the engine operation to be a subset of that from the high-output configuration, you may use the fuel-consumption rates for the reduced number of mapped points for the low-output configuration, as long as the narrower map includes at least 70 points. Perform fuel mapping as follows:

(1) Generate the fuel-mapping sequence of ~~steady-state engine~~ speed and torque set ~~operating~~ points as follows:

(i) ~~Determine the required steady-state engine operating points as follows:~~

~~(A) For engines with an adjustable warm idle speed setpoint, s~~ Select the following required speed setpoints: ~~minimum~~ warm idle speed, $f_{\text{idle min}}$, the highest speed above maximum power at which 70 % of maximum power occurs, n_{hi} , and eight (or more) equally spaced points between $f_{\text{idle min}}$ and n_{hi} . (See 40 CFR 1065.610(c)). For engines ~~without an~~ adjustable warm idle speed, replace f_{idle} with minimum warm idle speed ~~with warm idle speed, $f_{\text{idle min}}$.~~

~~(Bii) Select~~ Determine the following default torque setpoints at each of the selected speed setpoints: zero ($T = 0$), maximum mapped torque, $T_{\text{max mapped}}$, and eight (or more) equally spaced points between $T = 0$ and $T_{\text{max mapped}}$. Select the maximum torque setpoint at each speed to conform to the torque map as follows:

(A) Calculate 5 percent of $T_{\text{max mapped}}$. Subtract this result from the mapped torque at each speed setpoint, T_{max} .

- (B) Select T_{max} at each speed setpoint as a single torque value to represent all the default torque setpoints above the value determined in paragraph (b)(1)(ii)(A) of this section. All the default torque setpoints less than T_{max} at a given speed setpoint are required torque setpoints.
- ~~(iii) Select~~ You may select any additional ~~(optional) steady-state engine operating speed and torque set-~~points consistent with good engineering judgment. For example you may ~~need to~~ select additional points if the engine's fuel consumption is nonlinear across the torque map when linear interpolation between the defined points is not a reasonable assumption for determining fuel consumption from the engine. Avoid creating a problem with interpolation between narrowly spaced speed and torque setpoints near T_{max} . For each additional speed setpoint, we recommend including a torque setpoint of T_{max} ; however, you may select torque setpoints that properly represent in-use operation. Increments for ~~increments between~~ increments between torque setpoints between these minimum and maximum values at an additional speed setpoint must be no ~~more~~ larger than one-ninth of ~~$T_{max, mapped}$ and we recommend including a torque setpoint of T_{max} .~~ If you select a maximum torque setpoint less than T_{max} , use good engineering judgment to select your maximum torque setpoint to avoid unrepresentative data. Note that if the test points were added for the child rating, they should still be reported in the parent fuel map. We will ~~select test with~~ at least as many points as you. If you add test points to meet testing requirements for child ratings, include those same test points as reported values for the parent fuel map. For our testing, we will use the same normalized speed and torque test points you use, and we may select additional test points.
- ~~(ivii) Start fuel-map testing at~~ Set the run order for all of the steady-state engine operating points (both required and optional) as described in this paragraph (b)(1)(iii). Arrange the list of steady-state engine operating points such that the resulting list of paired speed and torque setpoints begins with the highest speed setpoint and highest torque setpoint, followed by decreasing torque setpoints at the highest speed setpoint. ~~This will be followed by~~ Continue testing at the next lowest speed setpoint and the highest torque setpoint at that speed setpoint, followed by decreasing torque setpoints at that speed setpoint. Follow this pattern continuing through all the ~~steady-state engine operating speed and torque~~ points, and ending with the lowest speed (f_{idle} or $f_{idlemin}$) and torque setpoint ($T = 0$). The following figure ~~illustrates~~ provides an ~~example of this~~ array of test points and the corresponding run order.

Figure 1 of § 1036.535—Steady-State Engine Operation Fuel-Mapping Test Points and Run Order

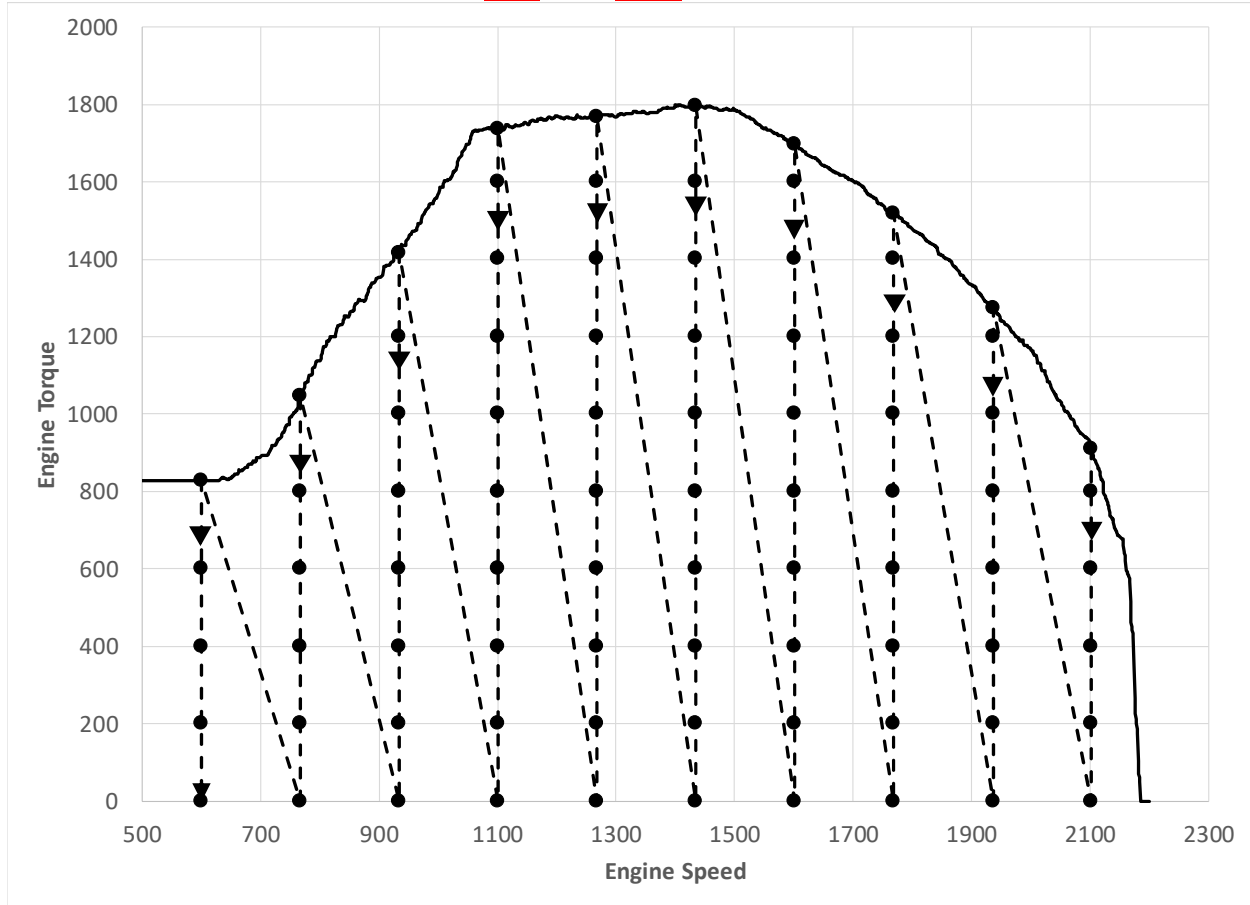

- (iv) ~~The steady-state engine operating points that have the highest torque setpoint for a given each speed setpoint are is an optional reentry points in to restart fuel mapping after an incomplete test run~~ the steady-state fuel mapping sequence, should you need to pause or interrupt the sequence during testing.
- (v) ~~The steady-state engine operating points that have the lowest torque setpoint for a given at each speed setpoint are is an optional exit points to interrupt from the steady-state fuel mapping sequence, should you need to pause or interrupt the sequence during testing.~~ Paragraph (b)(7) of this section describes how to interrupt testing at other times.
- (2) If the engine's ~~has an adjustable~~ warm idle speed ~~setpoint is adjustable~~, set it to its minimum value, f_{idlemin} .
- (3) ~~The measurement at each unique combination of speed and torque setpoints constitutes a test interval. Unless we specify otherwise, you may program the dynamometer to control either speed or torque for a given test interval, with operator demand controlling the other parameter. During each test interval, eControl speed and torque so that all recorded speed points are within $\pm 1\%$ of m_{hi} from the target speed and all recorded engine torque points are within $\pm 5\%$ of T_{max} mapped from the target torque during each test interval, except for the following cases where both setpoints cannot be achieved because the steady-state engine operating point is near an engine operating boundary as follows:~~

(i) For steady-state engine operating points that cannot be achieved, and the operator demand stabilizes at minimum; ~~control program~~ the dynamometer ~~so it gives priority to follow the control~~ torque ~~setpoint~~ and let the engine govern ~~the~~ speed (see 40 CFR 1065.512(b)(1)). Control torque so that all recorded ~~In this case, the tolerance on speed control in paragraph (b)(3) of this section does not apply and~~ engine torque ~~is controlled to points are~~ within ± 25 N·m ~~from the target torque~~. The specified speed tolerance does not apply for the test interval.

(ii) For steady-state engine operating points that cannot be achieved and the operator demand stabilizes at maximum and the speed setpoint is below 90 % of n_{hi} even with maximum operator demand, program; ~~control~~ the dynamometer ~~so it gives priority to follow the to control~~ speed ~~setpoint~~ and let the engine govern ~~the~~ torque (see 40 CFR 1065.512(b)(2)). ~~In this case, the~~ specified torque tolerance ~~on torque control given in paragraph (b)(3) of this section~~ does not apply for the test interval.

(iii) For steady-state engine operating points that cannot be achieved and the operator demand stabilizes at maximum and the speed setpoint is at or above 90 % of n_{hi} even with maximum operator demand, program; ~~control~~ the dynamometer ~~so it gives priority to follow the to control~~ torque ~~setpoint~~ and let the engine govern ~~the~~ speed (see 40 CFR 1065.512(b)(1)). ~~In this case, the~~ tolerance on specified speed ~~control given in paragraph (b)(3) of this section~~ tolerance does not apply for the test interval.

(iv) For the steady-state engine operating points at the minimum speed setpoint and maximum torque setpoint, you may select a program the dynamometer to control mode ~~that gives priority to speed and~~ an let the engine ~~control mode that gives priority to govern~~ torque. ~~In this case, if the operator demand stabilizes at minimum or maximum, the specified torque~~ tolerance ~~on torque control in paragraph (b)(3) of this section~~ does not apply for this test interval if operator demand stabilizes at its maximum or minimum limit.

(4) Record measurements using direct and/or indirect measurement of fuel flow as follows: ~~You may select the appropriate dynamometer and engine control modes in real time or at any time prior based on various factors including the operating setpoint location relative to an engine operating boundary. Warm-up the engine as described in 40 CFR 1065.510(b)(2).~~

(5) ~~Within 60 seconds after concluding the warm-up, linearly ramp the speed and torque setpoints over 5 seconds to the first steady state engine operating point from paragraph (b)(1) of this section.~~

(6) ~~Operate the engine at the steady state engine operating point for (70 ± 1) seconds, and then start the test interval and record measurements using one of the following methods. You must also measure and report NO_x emissions over each test interval as described in paragraph (a)(2) of this section. If you use redundant systems for the determination of fuel consumption, for example combining measurements of dilute and raw emissions when generating your map, follow the requirements of 40 CFR 1065.201(d).~~

(i) Direct fuel-flow measurement of fuel flow. Record speed and torque and measure fuel consumption with a fuel flow meter for a (30 ± 1) seconds. Test interval; ~~determine the corresponding mean values for the test interval.~~ Use of redundant direct fuel-flow measurements require prior EPA approval.

(ii) Indirect fuel-flow measurement of fuel flow. Record speed and torque and measure emissions and other inputs needed to run the chemical balance in 40 CFR 1065.655(c) for

~~a-(30 ± 1) seconds. test interval;~~ Determine the corresponding mean values for the test interval. Use of redundant indirect fuel-flow measurements require prior EPA approval. Measure background concentration as described in 40 CFR 1065.140, except that you may use one of the following methods to apply a single background reading to multiple test intervals.~~For dilute sampling of emissions, in addition to the background measurement provisions described in 40 CFR 1065.140 you may do the following:~~

~~(A) If you use batch sampling to measure background emissions~~For batch sampling, you may sample periodically into the bag over the course of multiple test intervals and read them as allowed in paragraph (b)(~~407~~)(i) of this section. You must determine a single background reading for all affected test intervals ~~if you use the method described in this paragraph (b)(4)(ii)(A) this provision, you must apply the same background readings to correct emissions from each of the applicable test intervals.~~

~~(B) You may determine-measure background emissions-concentration by sampling from the dilution air during the non-test interval periods in the test sequence, including pauses~~interruptions allowed in paragraph (b)(~~407~~)(i) of this section or at other times before or after test intervals. Measure background concentration within 30 minutes before the first test interval and within 30 minutes before each reentry point. Measure the corresponding background concentration within 30 minutes after each exit point and within 30 minutes after the final test interval. You may measure background concentration more frequently. Correct measured emissions for test intervals between a pair of background readings based on the average of those two values. Once the system stabilizes, collect a background sample over an averaging period of at least 30 seconds.

(5) Warm up the engine as described in 40 CFR 1065.510(b)(2). Within 60 seconds after concluding the warm-up, linearly ramp the speed and torque setpoints over 5 seconds to the starting test point ~~first steady-state engine operating point~~ from paragraph (b)(1) of this section.

(6) ~~Operate-Stabilize~~ the engine by operating at the specified speed and torque setpoints ~~steady-state engine operating point~~ for (70 ± 1) seconds, and then start the test interval. and ~~r~~Record measurements during the test interval ~~methods.~~ You must also mMeasure and report NO_x emissions over each test interval as described in paragraph (f)(~~a~~)(2) of this section. ~~If you use redundant systems for the determination of fuel consumption, for example combining measurements of dilute and raw emissions when generating your map, follow the requirements of 40 CFR 1065.201(d).~~

(7) After completing ~~the a~~ test interval ~~described in paragraph (b)(6) of this section,~~ linearly ramp the speed and torque setpoints over 5 seconds to the next ~~steady-state engine operating~~ test point.

(i) You may pause-interrupt the ~~steady-state-fuel-mapping~~ sequence at any of the ~~before a reentry points~~ ~~(as noted in paragraphs (b)(1)(iv) and (vi) of this section.~~ If you zero and span analyzers, read and evacuate background bag samples, or sample dilution air for a background reading during the interruption, the maximum time to stabilize in paragraph (b)(6) of this section does not apply. If you shut off the engine, restart with engine warm-up as described in paragraph (b)(5) of this section. ~~to calibrate emission measurement instrumentation; to read and evacuate background bag samples collected over the course of multiple test intervals; or to sample the dilution air for background emissions. This~~

~~provision allows you to spend more than the 70 seconds noted in paragraph (b)(6) of this section.~~

~~(ii) You may interrupt the fuel-mapping sequence at a given speed setpoint before completing measurements at that speed. If this happens, you may measure background concentration and take other action as needed to validate test intervals you completed before the most recent reentry point. Void all test intervals after the last reentry point. Restart testing at the appropriate reentry point in the same way that you would start a new test. Operate the engine long enough to stabilize aftertreatment thermal conditions, even if it takes more than 70 seconds. In the case of an infrequent regeneration event, interrupt the fuel-mapping sequence and allow the regeneration event to finish with the engine operating at a speed and load that allows effective regeneration.~~

~~(iii) If you void any one test interval, all the testing at that speed setpoint is also void. Restart testing by repeating the fuel-mapping sequence as described in this paragraph (b); include all voided speed setpoints and omit testing at speed setpoints that already have a full set of valid results.~~

~~(ii) If an infrequent regeneration event occurs, interrupt the steady-state fuel-mapping sequence and allow the regeneration event to finish. You may continue to operate at the steady-state engine operating point where the event began or, using good engineering judgment, you may transition to another operating condition to reduce the regeneration event duration. You may complete any post-test interval activities to validate test intervals prior to the most recent reentry point. Once the regeneration event is finished, linearly ramp the speed and torque setpoints over 5 seconds to the most recent reentry point described in paragraph (b)(1)(iv) of this section, and restart the steady-state fuel-mapping sequence by repeating the steps in paragraphs (b)(6) and (7) of this section for all the remaining steady-state engine operating points. Operate at the reentry point for longer than the 70 seconds in paragraph (b)(6), as needed, to bring the aftertreatment to representative thermal conditions. Void all test intervals in the steady-state fuel-mapping sequence beginning with the reentry point and ending with the steady-state engine operating point where the regeneration event began.~~

~~(iii) You may interrupt the steady-state fuel-mapping sequence after any of the exit points described in paragraph (b)(1)(v) of this section. To restart the steady-state fuel-mapping sequence; begin with paragraph (b)(4) of this section and continue with paragraph (b)(5) of this section, except that the steady-state engine operating point is the next reentry point, not the first operating point from paragraph (b)(1) of this section. Follow paragraphs (b)(6) and (7) of this section until all remaining steady-state engine operating points are tested.~~

~~(iv) If the steady-state fuel-mapping sequence is interrupted due test equipment or engine malfunction, void all test intervals in the steady-state fuel-mapping sequence beginning with the most recent reentry point as described in paragraph (b)(1)(iv) of this section. Complete any post-test interval activities to validate test intervals prior to the most recent reentry point. Correct the malfunction and restart the steady-state fuel-mapping sequence as described in paragraph (b)(7)(iii) of this section.~~

~~(v) If any steady-state engine test interval is voided, void all test intervals in the steady-state fuel-mapping sequence beginning with the most recent reentry point as described in paragraph (b)(1)(iv) of this section and ending with the next exit point as described in paragraph (b)(1)(v) of this section. Rerun that segment of the steady-state fuel-mapping sequence. If multiple test intervals are voided in multiple speed setpoints, you may~~

~~exclude the speed setpoints where all of the test intervals were valid from the rerun sequence. Rerun the steady-state fuel mapping sequence as described in paragraph (b)(10)(iii) of this section.~~

(8) If you determine fuel-consumption rates using emission measurements from the raw or diluted exhaust, calculate the mean fuel mass flow rate, \bar{m}_{fuel} , for each point in the fuel map using the following equation:

$$\bar{m}_{\text{fuel}} = \frac{M_C}{w_{\text{Cmeas}}} \cdot \left(\bar{n}_{\text{exh}} \cdot \frac{\bar{x}_{\text{Ccombdry}}}{1 + \bar{x}_{\text{H}_2\text{Oexhdry}}} - \frac{\bar{m}_{\text{CO}_2\text{DEF}}}{M_{\text{CO}_2}} \right)$$

Eq. 1036.535-1

Where:

\bar{m}_{fuel} = mean fuel mass flow rate for a given fuel map setpoint, expressed to at least the nearest 0.001 g/s.

M_C = molar mass of carbon.

w_{Cmeas} = carbon mass fraction of fuel (or mixture of test fuels) as determined in 40 CFR 1065.655(d), except that you may not use the default properties in Table 24 of 40 CFR 1065.655 to determine α , b , and w_C . You may not account for the contribution to α , β , γ , and δ of diesel exhaust fluid or other non-fuel fluids injected into the exhaust.

\bar{n}_{exh} = the mean raw exhaust molar flow rate from which you measured emissions according to 40 CFR 1065.655.

$\bar{x}_{\text{Ccombdry}}$ = the mean concentration of carbon from fuel and any injected fluids in the exhaust per mole of dry exhaust as determined in 40 CFR 1065.655(c).

$\bar{x}_{\text{H}_2\text{Oexhdry}}$ = the mean concentration of H₂O in exhaust per mole of dry exhaust as determined in 40 CFR 1065.655(c).

$\bar{m}_{\text{CO}_2\text{DEF}}$ = the mean CO₂ mass emission rate resulting from diesel exhaust fluid decomposition as determined in paragraph (b)(9) of this section. If your engine does not use diesel exhaust fluid, or if you choose not to perform this correction, set $\bar{m}_{\text{CO}_2\text{DEF}}$ equal to 0.

M_{CO_2} = molar mass of carbon dioxide.

Example:

$M_C = 12.0107$ g/mol

$w_{\text{Cmeas}} = 0.869$

$\bar{n}_{\text{exh}} = 25.534$ mol/s

$\bar{x}_{\text{Ccombdry}} = 0.002805$ mol/mol

$\bar{x}_{\text{H}_2\text{Oexhdry}} = 0.0353$ mol/mol

$\bar{m}_{\text{CO}_2\text{DEF}} = 0.0726$ g/s

$M_{\text{CO}_2} = 44.0095$ g/mol

$$\bar{m}_{\text{fuel}} = \frac{12.0107}{0.869} \cdot \left(25.534 \cdot \frac{0.002805}{1 + 0.0353} - \frac{0.0726}{44.0095} \right) = 0.933 \text{ g/s}$$

(9) If you determine fuel-consumption rates using emission measurements with engines that utilize diesel exhaust fluid for NO_x control and you correct for the mean CO₂ mass emission rate resulting from diesel exhaust fluid decomposition as described in paragraph (b)(8) of this section, perform this correction for the mean CO₂ mass emissions resulting from diesel exhaust fluid decomposition at each fuel map setpoint using the following equation:

$$\bar{m}_{\text{CO}_2\text{DEF}} = \bar{m}_{\text{DEF}} \cdot \frac{M_{\text{CO}_2} \cdot w_{\text{CH}_4\text{N}_2\text{O}}}{M_{\text{CH}_4\text{N}_2\text{O}}}$$

Eq. 1036.535-2

Where:

\bar{m}_{DEF} = the mean mass flow rate of injected urea solution diesel exhaust fluid for a given sampling period, determined directly from the ~~electronic control module~~ ECM, or measured separately, consistent with good engineering judgment.

M_{CO_2} = molar mass of carbon dioxide.

$w_{\text{CH}_4\text{N}_2\text{O}}$ = mass fraction of urea in diesel exhaust fluid aqueous solution. Note that the subscript “CH₄N₂O” refers to urea as a pure compound and the subscript “DEF” refers to the aqueous urea diesel exhaust fluid as a solution of urea in water. You may use a default value of 32.5 % or use good engineering judgment to determine this value based on measurement.

$M_{\text{CH}_4\text{N}_2\text{O}}$ = molar mass of urea.

Example:

$$\bar{m}_{\text{DEF}} = 0.304 \text{ g/s}$$

$$M_{\text{CO}_2} = 44.0095 \text{ g/mol}$$

$$w_{\text{CH}_4\text{N}_2\text{O}} = 32.5 \% = 0.325$$

$$M_{\text{CH}_4\text{N}_2\text{O}} = 60.05526 \text{ g/mol}$$

$$\bar{m}_{\text{CO}_2\text{DEF}} = 0.304 \cdot \frac{44.0095 \cdot 0.325}{60.05526} = 0.0726 \text{ g/s}$$

(c) *Fuel consumption at idle.* Determine fuel-consumption rates at idle for each engine configuration that is certified for installation in vocational vehicles. Determine fuel-consumption rates at idle by testing engines for each engine configuration over a series of engine idle operating points consisting of pairs of engine speed and torque setpoints as described in this paragraph (c). ~~You may use shared data across engine configurations, consistent with good engineering judgment.~~ Perform measurements as follows:

(1) The idle test sequence consists of measuring fuel consumption at four test points representing each combination of the following speed and torque setpoints in any order. ~~Determine the required engine idle operating points as follows:~~

(i) Speed setpoints for e ~~Select the following two speed setpoints:~~

~~(A) Engines with an adjustable warm idle speed setpoint: are~~ minimum warm idle speed, f_{idlemin} , and ~~the~~ maximum warm idle speed, f_{idlemax} . Speed setpoints for

~~(B) E~~ engines without an no adjustable warm idle speed ~~setpoint: warm idle speed~~ (with zero torque on the primary output shaft), are f_{idle} , and 1.15 times f_{idle} .

(ii) ~~Select the following two t~~ Torque setpoints at each of the selected speed setpoints: are 0 and 100 N·m.

~~(iii) You may run these four engine idle operating points in any order.~~

(2) Control speed and torque as follows:

(i) Engines with an a ~~Adjustable warm idle speed setpoint.~~ Set the engine’s warm idle speed to the next speed setpoint any time before the engine reaches the next test point.

Control both speed and torque when the engine is warming up and when it is transitioning to the next test point. Start to control both speed and torque. At any time

prior to reaching the next engine-idle operating point, set the engine’s adjustable warm idle speed setpoint to the speed setpoint of the next engine-idle operating point in the

sequence. This may be done before or during the warm-up or during the transition. Near

the end of the transition period control speed and torque as described in paragraph (b)(3)(i) of this section shortly before reaching each test point. Once the engine is operating at the desired speed and torque setpoints, transition is complete; set the operator demand to minimum ~~to allow the engine governor to control speed; and control torque so that all recorded engine torque points are within ± 25 N·m from the target torque~~ with the dynamometer as described in paragraph (b)(3) of this section.

(ii) ~~*Nonadjustable Engines without an adjustable warm idle speed setpoint*~~. For the lowest speed setpoint, control speed and torque as described in paragraph (c)(2)(i) of this section, except for adjusting the warm idle speed. For the second-lowest speed setpoint, control speed and torque so that all recorded speed points are within ± 1 % of m_{hi} from the target speed and engine torque within ± 5 % of T_{max} mapped from the target torque. ~~Control speed and torque with operator demand and the dynamometer for the engine idle operating points at the higher speed setpoint as described in paragraph (b)(3) of this section. Both the speed and torque tolerances apply for these points because they are not near the engine's operating boundary and are achievable. Control speed and torque for the engine idle operating points at the lower speed setpoint as described in paragraph (e)(2)(i) of this section except for setting the engine's adjustable warm idle speed setpoint.~~

(3) Record measurements using direct and/or indirect measurement of fuel flow as follows: ~~Warm up the engine as described in 40 CFR 1065.510(b)(2).~~

(ii) ~~*Direct measurement of fuel flow measurement*~~. Record speed and torque and measure fuel consumption with a fuel flow meter for ~~a~~ (600 \pm 1) seconds. Dtest interval; ~~determine the corresponding mean values for the test interval.~~ Use of redundant direct fuel-flow measurements require prior EPA approval.

(i) ~~*Indirect measurement of fuel flow measurement*~~. Record speed and torque and measure emissions and other inputs needed to run the chemical balance in 40 CFR 1065.655(c) for ~~a~~ (600 \pm 1) seconds. Dtest interval; ~~determine the corresponding mean values for the test interval.~~ Use of redundant indirect fuel-flow measurements require prior EPA approval. Measure background concentration as described in paragraph (b)(4)(ii) of this section ~~We will use an average of indirect measurement of fuel flow with dilute sampling and direct sampling. For dilute sampling of emissions, measure background according to the provisions described in 40 CFR 1065.140, but read the background as described in paragraph (e)(7)(i) of this section. If you use batch sampling to measure background emissions, you may sample periodically into the bag over the course of multiple test intervals and read them as allowed in paragraph (b)(10)(i) of this section. If you use this paragraph (e)(5)(i), you must apply the same background readings to correct emissions from each of the applicable test intervals. Note that the minimum dilution ratio requirements for PM sampling in 40 CFR 1065.140(e)(2) do not apply. We recommend minimizing setting the CVS flow rate as low as possible to minimize background, but without introducing errors related to insufficient mixing or other operational considerations to minimize errors due to background correction consistent with good engineering judgment and operational constraints such as minimum flow rate for good mixing. Note that for this testing 40 CFR 1065.140(e) does not apply, including the minimum dilution ratio of 2:1 in the primary dilution stage.~~

(4) Warm up the engine as described in 40 CFR 1065.510(b)(2). Within 60 seconds after concluding the warm-up ~~After concluding the warm-up procedure~~, linearly ramp the speed

and torque ~~setpoints~~ over 20 seconds to the first speed and torque setpoint ~~operate the engine at the next engine-idle operating point from paragraph (e)(1) of this section.~~

(5) The measurement at each unique combination of speed and torque setpoints constitutes a test interval. Operate the engine at the selected speed and torque setpoints ~~engine-idle operating points~~ for (180 ± 1) seconds, and then start the test interval ~~and r.~~ Record measurements using one of the following methods during the test interval. You must also ~~m~~ Measure and report NO_x emissions over each test interval as described in paragraph (af)(2) of this section. ~~If you use redundant systems for the determination of fuel consumption, for example combining measurements of dilute and raw emissions when generating your map, follow the requirements of 40 CFR 1065.201(d).~~

(6) After completing each ~~the~~ test interval ~~described in paragraph (e)(5) of this section,~~ repeat the steps in paragraphs (c)(34) and to (5) ~~of this section for all the remaining engine-idle operating~~ test points. ~~After completing the test interval on the last engine-idle operating point, the fuel consumption at idle sequence is complete.~~

(7) Each test point represents a stand-alone measurement. You may therefore take any appropriate steps between test intervals to process collected data and to prepare engines and equipment for further testing. Note that the allowances for combining background in paragraph (b)(4)(ii)(B) of this section do not apply. If an infrequent regeneration event occurs, allow the regeneration event to finish; void the test interval if the regeneration starts during a measurement.

(8) Correct the measured or calculated mean fuel mass flow rate, at each of the engine-idle operating points to account for mass-specific net energy content as described in paragraph (b)(13) of this section.

(d) *Steady-state fuel maps used for cycle-average fuel mapping of the highway cruise cycles.* Determine steady-state fuel-consumption rates for each engine configuration over a series of paired engine speed and torque setpoints ~~steady-state engine operating points~~ near idle as described in this paragraph (d). ~~You may use shared data across an engine platform to the extent that the fuel consumption rates remain valid.~~ Perform fuel mapping as described in paragraph (b) of this section with the following exceptions:

(1) ~~Perform steady-state fuel mapping as described in paragraph (b) of this section with the following exceptions:~~ Select speed setpoints to cover a range of values to represent in-use operation at idle. Speed setpoints for engines with adjustable warm idle speed must include at least minimum warm idle speed, f_{idlemin} , and a speed at or above maximum warm idle speed, f_{idlemax} . Speed setpoints for engines with no adjustable idle speed must include at least warm idle speed (with zero torque on the primary output shaft), f_{idle} , and a speed at or above $1.15 \cdot f_{\text{idle}}$.

(2) Select the following torque setpoints at each speed setpoint to cover a range of values to represent in-use operation at idle:

(i) The minimum torque setpoint is zero.

(ii) Choose a maximum torque setpoint that is at least as large as the value determined by the following equation: ~~(i) All the required steady-state engine operating points as described in paragraph (b)(1)(i) of this section are optional.~~

$$T_{\text{idlemaxest}} = \left(\frac{T_{\text{finstall}} \cdot f_{\text{idle}}^2}{f_{\text{finstall}}^2} + \frac{P_{\text{acc}}}{f_{\text{idle}}} \right) \cdot 1.1$$

Eq. 1036.535-3

Where:

T_{finstall} = the maximum engine torque at f_{finstall} .

f_{fidle} = for engines with an adjustable warm idle speed, use the maximum warm idle speed, f_{fidlemax} the applicable engine idle speed as described in this paragraph (d). For engines without an adjustable warm idle speed, use warm idle speed, f_{fidle} .

f_{finstall} = the stall speed of the torque converter; use f_{fntest} or 2250 r/min, whichever is lower.

P_{acc} = accessory power for the vehicle class; use 1500 W for Vocational Light HDV, 2500 W for Vocational Medium HDV, and 3500 W for Tractors and Vocational Heavy HDV. If your engine is going to be installed in multiple vehicle classes, perform the test with the accessory power for the largest vehicle class the engine will be installed in.

Example:

$$T_{\text{finstall}} = 1870 \text{ N}\cdot\text{m}$$

$$f_{\text{fntest}} = 1740.8 \text{ r/min} = 182.30 \text{ rad/s}$$

$$f_{\text{finstall}} = 1740.8 \text{ r/min} = 182.30 \text{ rad/s}$$

$$f_{\text{fidle}} = 700 \text{ r/min} = 73.30 \text{ rad/s}$$

$$P_{\text{acc}} = 1500 \text{ W}$$

$$T_{\text{idlemaxest}} = \left(\frac{1870 \cdot 73.30^2}{182.30^2} + \frac{1500}{73.30} \right) \cdot 1.1 = 355.07 \text{ N}\cdot\text{m}$$

(iii) Select one or more equally spaced intermediate torque setpoints, as needed, such that the increment between torque setpoints is no greater than one-ninth of $T_{\text{max,mapped}}$. (2)

Remove the points from the default map that are below 115 % of the maximum speed and 115% of the maximum torque of the boundaries of the points measured in paragraph (d)(1) of this section.

~~(3) Add the points measured in paragraph (d)(1) of this section.~~

~~(e) Carbon balance verification. The provisions related to carbon balance verification in § 1036.543 apply to test intervals in this section.~~

~~(e) Correction for net energy content.~~ Correct the measured or calculated mean fuel mass flow rate, \bar{m}_{fuel} , at each engine operating condition as specified in paragraphs (b), (c), and (d) of this section for each test interval to a mass-specific net energy content of a reference fuel using the following equation:

$$\bar{m}_{\text{fuelcor}} = \bar{m}_{\text{fuel}} \cdot \frac{E_{\text{mfuelmeas}}}{E_{\text{mfuelCref}} \cdot W_{\text{Cref}}}$$

Eq. 1036.535-4

Where:

$E_{\text{mfuelmeas}}$ = the mass-specific net energy content of the test fuel as determined in § 1036.530(b)(1).

$E_{\text{mfuelCref}}$ = the reference value of carbon-mass-specific net energy content for the appropriate fuel. Use the values shown in Table 1 of § 1036.530 for the designated fuel types, or values we approve for other fuel types.

W_{Cref} = the reference value of carbon mass fraction for the test fuel as shown in Table 1 of § 1036.530 for the designated fuels. For any other fuel not identified in the tables, use the reference carbon mass fraction of diesel fuel for engines subject to compression-ignition

standards, and use the reference carbon mass fraction of gasoline for engines subject to spark-ignition standards.

Example:

$$\bar{m}_{\text{fuel}} = 0.933 \text{ g/s}$$

$$E_{\text{mfuelmeas}} = 42.7984 \text{ MJ/kgC}$$

$$E_{\text{mfuelCref}} = 49.3112 \text{ MJ/kgC}$$

$$w_{\text{Cref}} = 0.874$$

$$\bar{m}_{\text{fuel}} = 0.933 \cdot \frac{42.7984}{49.3112 \cdot 0.874} = 0.927 \text{ g/s}$$

(f) Measuring NO_x emissions. Measure NO_x emissions for each sampling period in g/s. You may perform these measurements using a NO_x emission-measurement system that meets the requirements of 40 CFR part 1065, subpart J. If a system malfunction prevents you from measuring NO_x emissions during a test under this section but the test otherwise gives valid results, you may consider this a valid test and omit the NO_x emission measurements; however, we may require you to repeat the test if we determine that you inappropriately voided the test with respect to NO_x emission measurement.

(g) Measured vs. declared fuel-consumption rates. Determine declared fuel consumption as follows:

(1) Select fuel-consumption rates in g/s to characterize the engine's fuel maps. You must select a declared value for each test point that is at or above the ~~These declared values may not be lower than any~~ corresponding ~~measured~~ values determined in paragraphs (b) through ~~(d)~~ of this section, including those from redundant measurements.

(2) ~~This includes if you use multiple measurement methods as allowed in paragraph (b)(7) of this section. You may select any value that is at or above the corresponding measured value. These d~~Declared fuel-consumption rates, which serve as emission standards under § 1036.108, These are the values that vehicle manufacturers will use for certification under 40 CFR part 1037. Note that production engines are subject to GEM cycle-weighted limits as described in § 1036.301.

(3) If you perform the carbon balance error verification, select declared values that are at or above the following emission measurements in § 1036.543, for each fuel map data point:

(1) If you pass the ϵ_{rC} verification, you must declare fuel consumption rates no lower than you may use the average of the values from direct and indirect fuel measurements.

(2) If you fail ϵ_{rC} verification, but pass either the ϵ_{aC} verification ~~or ϵ_{aCrate} verification~~ and ~~fail the ϵ_{rC} verification~~, you must declare fuel consumption rates no lower than use the value from indirect fuel measurement.

(3) If you ~~don't pass the ϵ_{rC} , ϵ_{aC} , and ϵ_{aCrate}~~ fail all three verifications, you must either void the test interval or you must declare fuel consumption rates no lower than use the highest ~~rate for the~~ value from direct and indirect fuel measurements. Note that we will consider our test results to be invalid if we fail all three verifications.

(h) EPA measured fuel consumption rates. If we pass the carbon mass relative error for a test interval (ϵ_{rC}) verification, the official fuel consumption rate result will be the average of the direct and indirect fuel measurements. If we pass either the carbon mass absolute error for a test interval (ϵ_{aC}) verification or carbon mass rate absolute error for a test interval (ϵ_{aCrate}) verification and fail the ϵ_{rC} verification, the official fuel consumption rate result will be the indirect fuel measurement.

§ 1036.540 Determining cycle-average engine fuel maps.

(a) *Overview.* This section describes how to determine an engine’s cycle-average fuel maps for model year 2021 and later vehicles ~~with transient cycles. This section may also apply for highway cruise cycles as described in § 1036.510.~~ Vehicle manufacturers may need cycle-average fuel maps for transient duty cycles, highway cruise cycles, or both one or both of these to demonstrate compliance with emission standards under 40 CFR part 1037. ~~Generating~~ cycle-average engine fuel maps ~~consists of the following steps as follows:~~

- (1) Determine the engine’s torque maps as described in § 1036.50340(ca).
- (2) Determine the engine’s steady-state fuel map and fuel consumption at idle as described in § 1036.535. If you are applying cycle-average fuel mapping for highway cruise cycles, you may instead use GEM’s default fuel map instead of generating the steady-state fuel map in § 1036.535(b).
- (3) Simulate several different vehicle configurations using GEM (see 40 CFR 1037.520) to create new engine duty cycles, as described in paragraph (c) of this section. The transient vehicle duty cycles for this simulation are in 40 CFR part 1037, appendix AI; the highway cruise cycles with grade are in 40 CFR part 1037, appendix DIV. Note that GEM simulation relies on vehicle service classes as described in 40 CFR 1037.140.
- (4) Test the engines using the new duty cycles to determine fuel consumption, cycle work, and average vehicle speed as described in paragraph (d) of this section and establish GEM inputs for those parameters for further vehicle simulations as described in paragraph (e) of this section.

(b) *General test provisions.* The following provisions apply for testing under this section:

- (1) To perform fuel mapping under this section for hybrid engines, make sure the engine and its hybrid features are appropriately configured to represent the hybrid features in your testing.
- (2) Measure NO_x emissions for each specified sampling period in grams. You may perform these measurements using a NO_x emission-measurement system that meets the requirements of 40 CFR part 1065, subpart J. Include these measured NO_x values any time you report to us your fuel consumption values from testing under this section. If a system malfunction prevents you from measuring NO_x emissions during a test under this section but the test otherwise gives valid results, you may consider this a valid test and omit the NO_x emission measurements; however, we may require you to repeat the test if we determine that you inappropriately voided the test with respect to NO_x emission measurement.

(3) The provisions related to carbon balance error verification in § 1036.543 apply for all testing in this section. These procedures are optional, but we will perform carbon balance error verification for all testing under this section.

(4) Correct fuel mass flow rate to a mass-specific net energy content of a reference fuel as described in paragraph (d)(13) of this section.

~~(3)~~ This section uses engine parameters and variables that are consistent with 40 CFR part 1065.

~~(4) For variable-speed gaseous-fueled engines with a single-point fuel injection system, apply all of the following statistical criteria to validate the transient duty cycle in 40 CFR part 1037, appendix I:~~

Parameter	Speed	Torque	Power
Slope, a_1			

Absolute value of intercept, $ \alpha_0 $		$\leq 3\%$ of maximum mapped torque	$\leq 2\%$ of maximum mapped power
Standard error of the estimate, SEE		$\leq 15\%$ of maximum mapped torque	$\leq 15\%$ of maximum mapped power
Coefficient of determination, r^2		≥ 0.700	≥ 0.750

(c) *Create engine duty cycles.* Use GEM to simulate your engine operation with several different vehicle configurations to create transient and highway cruise engine duty cycles corresponding to each vehicle configuration, as follows:

(1) Set up GEM to simulate your engine's vehicle operation based on your engine's torque maps, steady-state fuel maps, engine minimum warm-idle speed as defined in 40 CFR 1037.520(h)(1), and fuel consumption at idle as described in paragraphs (a)(1) and (2) of this section, as well as 40 CFR 1065.405(b). For engines without an adjustable warm idle speed replace minimum warm idle speed with warm idle speed, f_{idle} .

(2) Set up GEM with transmission parameters for different vehicle service classes and vehicle duty cycles. Specify the transmission's torque limit for each gear as the engine's maximum torque as determined in 40 CFR 1065.510. Specify the transmission type as Automatic Transmission for all engines and for all engine and vehicle duty cycles, except that the transmission type is Automated Manual Transmission for Heavy HDE operating over the highway cruise cycles or the SET duty cycle. For automatic transmissions set neutral idle to "Y" in the vehicle file. Select gear ratios for each gear as shown in the following table: These values are based on automatic or automated manual transmissions, but they apply for all transmission types.

Table 2 to § 1036.540—Assigned Transmission Parameters

Transmission Type	Automatic Transmission		Automatic Transmission		Automated Manual Transmission	
	Gear Ratio	Torque Limit (N·m)	Gear Ratio	Torque Limit (N·m)	Gear Ratio	Torque Limit (N·m)
1	3.10	T_{max}	3.51	T_{max}	12.8	T_{max}
2	1.81		1.91		9.25	
3	1.41		1.43		6.76	
4	1.00		1.00		4.90	
5	0.71		0.74		3.58	
6	0.61		0.64		2.61	
7					1.89	
8					1.38	
9					1.00	
10					0.73	
Lockup Gear	3				—	

Table 1 of § 1036.540—GEM Input for Gear Ratio

<u>Gear Number</u>	<u>Spark-ignition HDE, Light HDE, and Medium HDE— All Engine and Vehicle Duty Cycles</u>	<u>Heavy HDE— Transient and FTP Duty Cycles</u>	<u>Heavy HDE— Cruise and SET Duty Cycles</u>
<u>1</u>	<u>3.10</u>	<u>3.51</u>	<u>12.8</u>
<u>2</u>	<u>1.81</u>	<u>1.91</u>	<u>9.25</u>
<u>3</u>	<u>1.41</u>	<u>1.43</u>	<u>6.76</u>
<u>4</u>	<u>1.00</u>	<u>1.00</u>	<u>4.90</u>
<u>5</u>	<u>0.71</u>	<u>0.74</u>	<u>3.58</u>
<u>6</u>	<u>0.61</u>	<u>0.64</u>	<u>2.61</u>
<u>7</u>	<u>—</u>	<u>—</u>	<u>1.89</u>
<u>8</u>	<u>—</u>	<u>—</u>	<u>1.38</u>
<u>9</u>	<u>—</u>	<u>—</u>	<u>1.00</u>
<u>10</u>	<u>—</u>	<u>—</u>	<u>0.73</u>
<u>Lockup Gear</u>	<u>3</u>	<u>3</u>	<u>—</u>

(3) Run GEM for each simulated vehicle configuration and use the GEM outputs of instantaneous engine speed and engine flywheel torque for each vehicle configuration to generate a 10 Hz transient duty cycle corresponding to each vehicle configuration operating over each vehicle duty cycle. Run GEM for the specified number of vehicle configurations. You may run additional vehicle configurations to represent a wider range of in-use vehicles. Run GEM as follows:

- (i) *Determining axle ratio and tire size.* Set the axle ratio, k_a , and tire size, $\frac{f_{ntire}}{v_{vehicle}}$, for each vehicle configuration based on the corresponding designated engine speed (f_{nrefA} , f_{nrefB} , f_{nrefC} , f_{nrefD} , or f_{ntest} as defined in 40 CFR 1065.610(c)(2)) at 65 mi/hr for the transient duty cycle and for the 65 mi/hr highway cruise cycle. Similarly, set these parameters based on the corresponding designated engine speed at 55 mi/hr for the 55 mi/hr highway cruise cycle. Use one of the following equations to determine tire size, $\frac{f_{ntire}}{v_{vehicle}}$, and drive axle ratio, k_a , at each of the defined engine speeds in Tables 2 through 4 of this section:

- (A) Select a value for $\left[\frac{f_{ntire}}{v_{vehicle}}\right]_{[speed]}$ and solve for $k_{a[speed]}$ using the following equation:

$$k_{a[speed]} = \frac{f_{n[speed]}}{\left[\frac{f_{ntire}}{v_{vehicle}}\right]_{[speed]} \cdot k_{topgear} \cdot v_{ref}}$$

Eq. 1036.540-1

Where:

$f_{n[speed]}$ = engine's angular speed as determined in paragraph (c)(3)(ii) or (iii) of this section.

$k_{topgear}$ = transmission gear ratio in the highest available gear from Table 1 of this section (for powertrain testing use actual top gear ratio).

v_{ref} = reference speed. Use 65 mi/hr for the transient cycle and the 65 mi/hr highway cruise cycle and use 55 mi/hr for the 55 mi/hr highway cruise cycle.

(B) Select a value for $k_{a[\text{speed}]}$ and solve for $\left[\frac{f_{\text{ntire}}}{v_{\text{vehicle}}}\right]_{[\text{speed}]}$ using the following equation:

$$\left[\frac{f_{\text{ntire}}}{v_{\text{vehicle}}}\right]_{[\text{speed}]} = \frac{f_{n[\text{speed}]}}{k_{a[\text{speed}]} \cdot k_{\text{topgear}} \cdot v_{\text{ref}}}$$

Eq. 1036.540-2

Example for a vocational Light HDV or vocational Medium HDV with a 6-speed automatic transmission at B speed (Test 3 or 4 in Table 3 of this section):

$$f_{\text{refB}} = 1870 \text{ r/min} = 31.17 \text{ r/s}$$

$$k_{aB} = 4.0$$

$$k_{\text{topgear}} = 0.61$$

$$v_{\text{ref}} = 65 \text{ mi/hr} = 29.06 \text{ m/s}$$

$$\left[\frac{f_{\text{ntire}}}{v_{\text{vehicle}}}\right]_{\text{B}} = \frac{31.17}{4.0 \cdot 0.61 \cdot 29.06} = 0.4396 \text{ r/m}$$

(ii) *Vehicle configurations for Spark-ignition HDE, Light HDE, and Medium HDE.* Test at least eight different vehicle configurations for engines that will be installed in vocational Light HDV or vocational Medium HDV using vehicles **in the following table**; ~~in Table 2 of this section. For example, if your engines will be installed in vocational Medium HDV and vocational Heavy HDV, you might select Tests 2, 4, 6, and 8 of Table 3 of this section to represent vocational Medium HDV and Tests 2, 3, 4, 6, and 9 of Table 4 of this section to represent vocational Heavy HDV. You may test your engine using additional vehicle configurations with different k_a and C_{rr} values to represent a wider range of in-use vehicle configurations. For all vehicle configurations set the drive axle configuration to 4×2. For powertrain testing, set M_{rotating} to 340 kg and Eff_{axle} to 0.955 for all vehicle configurations. Set the axle ratio, k_a , and tire size, $\frac{f_{\text{ntire}}}{v_{\text{vehicle}}}$, for each vehicle configuration based on the corresponding designated engine speed (f_{refA} , f_{refB} , f_{refC} , or f_{ntest}) at 65 mi/hr for the transient cycle and the 65 mi/hr highway cruise cycle, and at 55 mi/hr for the 55 mi/hr highway cruise cycle. These vehicle speeds apply equally for engines subject to spark-ignition standards. Use the following settings specific to each vehicle configuration:~~

Table 23 to of § 1036.540—Vehicle Configurations for Testing Spark-ignition HDE, Light HDE, and Medium HDE Vocational Light HDV or Vocational Medium HDV

Parameter	Configuration							
	<u>1</u>	<u>2</u>	<u>3</u>	<u>4</u>	<u>5</u>	<u>6</u>	<u>7</u>	<u>8</u>
C_{rr} (N/kN/kg/tonne)	6.2	7.7	6.2	7.7	6.2	7.7	6.2	7.7
CI engine speed for $\frac{f_{ntire}}{v_{vehicle}}$ and k_a for CI engines at engine speed	f_{refA}	f_{refA}	f_{refB}	f_{refB}	f_{refC}	f_{refC}	f_{test} Maximum test speed	f_{test} Maximum test speed
SI engine speed for $\frac{f_{ntire}}{v_{vehicle}}$ and k_a for SI engines at engine speed	f_{refD} Minimum NTE exclusion speed	f_{refD} Minimum NTE exclusion speed	f_{refA}	f_{refA}	f_{refB}	f_{refB}	f_{refC}	f_{refC}
Drive Axle Configuration	4x2	4x2	4x2	4x2	4x2	4x2	4x2	4x2
GEM Regulatory Subcategory	LHD	MHD	LHD	MHD	LHD	MHD	LHD	MHD

(iii) Vehicle configurations for Heavy HDE. Test at least nine different vehicle configurations for engines that will be installed in vocational Heavy HDV and for tractors that are not heavy-haul tractors. Test six different vehicle configurations for engines that will be installed in heavy-haul tractors. You may test your engines for additional configurations with different k_a , C_{dA} , and C_{rr} values to represent a wider range of in-use vehicle configurations. Set C_{rr} to 6.9 for all nine defined vehicle configurations. For class 7 and 8 vehicle configurations set the drive axle configuration to 4x2 and 6x4 respectively. For powertrain testing, set Eff_{axle} to 0.955 for all vehicle configurations. Set the axle ratio, k_a , and tire size, $\frac{f_{ntire}}{v_{vehicle}}$, for each vehicle configuration based on the corresponding designated engine speed (B , f_{test} , or the minimum NTE exclusion speed as determined in 40 CFR 86.1370(b)(1)) at 65 mi/hr for the transient duty cycle and the 65 mi/hr highway cruise duty cycle, and at 55 mi/hr for the 55 mi/hr highway cruise duty cycle. Use the settings specific to each vehicle configuration as shown in Table 4-3 or Table 5-4 of this section, as appropriate. Engines subject to testing under both Table 4-3 and Table 4-5 of this section need not repeat overlapping vehicle configurations, so complete fuel mapping requires testing 12 (not 15) vehicle configurations for those engines. However, the preceding sentence does not apply if you choose to create two separate maps from the vehicle configurations defined in Table 3-4 and Table 5-4 of this section. Note that $M_{rotating}$ is needed for powertrain testing but not for engine testing. Tables 4-3 and 5-4 follow:

Table 34 of § 1036.540—Vehicle Configurations for Testing Heavy HDE Installed in General Purpose Tractors and Vocational Heavy HDV

Parameter	Configuration								
	<u>1</u>	<u>2</u>	<u>3</u>	<u>4</u>	<u>5</u>	<u>6</u>	<u>7</u>	<u>8</u>	<u>9</u>
C_{rr} (N/kN)	<u>6.9</u>	<u>6.9</u>	<u>6.9</u>	<u>6.9</u>	<u>6.9</u>	<u>6.9</u>	<u>6.9</u>	<u>6.9</u>	<u>6.9</u>
C_{dA}	5.4	4.7	4.0	5.4	4.7	4.0	5.4	4.7	4.0
Engine speed for $\frac{f_{ntire}}{v_{vehicle}}$ and k_a at engine speed	f_{nrefD} Minimum NTE exclusion speed	f_{nrefD} Minimum NTE exclusion speed	f_{nrefD} Minimum NTE exclusion speed	f_{nrefB}	f_{nrefB}	f_{nrefB}	f_{ntest} Maximum test speed	f_{ntest} Maximum test speed	f_{ntest} Maximum test speed
Drive Axle Configuration	<u>6x4</u>	<u>6x4</u>	<u>4x2</u>	<u>6x4</u>	<u>6x4</u>	<u>4x2</u>	<u>6x4</u>	<u>6x4</u>	<u>4x2</u>
GEM Regulatory Subcategory	C8_SC_HR	C8_DC_MR	C7_DC_MR	C8_SC_HR	C8_DC_MR	C7_DC_MR	C8_SC_HR	C8_DC_MR	C7_DC_MR
Vehicle Weight Reduction (lbs) ^a	0	13,275	6,147	0	13,275	6,147	0	13,275	6,147

Table 45 of § 1036.540—Vehicle Configurations for Testing Heavy HDE Installed in Heavy-Haul Tractors

Parameter	Configuration					
	<u>1</u>	<u>2</u>	<u>3</u>	<u>4</u>	<u>5</u>	<u>6</u>
C_{rr} (N/kN)	<u>6.9</u>	<u>6.9</u>	<u>6.9</u>	<u>6.9</u>	<u>6.9</u>	<u>6.9</u>
C_{dA}	5.0	5.4	5.0	5.4	5.0	5.4
Engine speed for $\frac{f_{ntire}}{v_{vehicle}}$ and k_a at engine speed	f_{nrefD} Minimum NTE exclusion speed	f_{nrefD} Minimum NTE exclusion speed	f_{nrefB}	f_{nrefB}	f_{ntest} Maximum test speed	f_{ntest} Maximum test speed
Drive Axle Configuration	<u>6x4</u>	<u>6x4</u>	<u>6x4</u>	<u>6x4</u>	<u>6x4</u>	<u>6x4</u>
GEM Regulatory Subcategory	C8_HH	C8_SC_HR	C8_HH	C8_SC_HR	C8_HH	C8_SC_HR

(iv) Vehicle configurations for mixed-use engines. If the engine will be installed in a combination of vehicles defined in paragraphs (c)(3)(ii) and (iii) of this section, use good engineering judgment to select at least nine vehicle configurations from Table 23 and Table 34 of this section that best represent the range of vehicles your engine will be sold in. This may require you to define If there are not nine representative configurations you must add additional representative vehicle_s, that you define, to reach a total of at least nine vehicles configurations. For example, if your engines will be installed in vocational Medium HDV and vocational Heavy HDV, you might select Tests 2, 4, 6 and 8 of Table 23 of this section to represent vocational Medium HDV and Tests 3, 6, and 9 of Table 34 of this section to represent vocational Heavy HDV and add two more vehicle configurations that you define. ~~You may test your engine using additional vehicle configurations with different k_a and C_{rr} values to represent a wider range of in-use vehicle configurations.~~

(v) Programming GEM. Use the defined values in Tables 12 through 45 of this section to set up GEM with the correct regulatory subcategory and vehicle weight reduction, if applicable, to achieve the target vehicle mass, M , for each test.

~~(4) Use the GEM output of instantaneous engine speed and engine flywheel torque for each of the vehicle configurations to generate a 10 Hz transient duty cycle corresponding to each vehicle configuration operating over each vehicle duty cycle.~~

(d) *Test the engine with GEM cycles.* Test the engine over each of the transient engine duty cycles generated in paragraph (c) of this section as follows:

(1) ~~Operate the engine over a~~ Determine the sequence of required and optional engine duty cycles ~~(both required and optional) for the cycle average fuel mapping sequence~~ as follows:

(i) Sort the list of engine duty cycles into three separate groups by vehicle duty cycle; transient vehicle duty cycle, 55 mi/hr highway cruise duty cycle, and ~~the~~ 65 mi/hr highway cruise duty cycle.

(ii) Within each group of engine duty cycles derived from the same vehicle duty cycle, ~~order the duty cycles as follows:~~ Select first run the engine duty cycle with the highest reference cycle work, followed by the cycle with the lowest cycle work; followed by the cycle with second-next highest cycle work, followed by the cycle with the second-next lowest cycle work; until continuing through all the cycles ~~are selected for that vehicle duty cycle.~~ The series of engine duty cycles to represent a single vehicle duty cycle is a single fuel-mapping sequence. Each engine duty cycle represents a different interval. Repeat the fuel-mapping sequence for the engine duty cycles derived from the other vehicle duty cycles until testing is complete.

(iii) Operate the engine over two full engine duty cycles to precondition before each interval in the fuel-mapping sequence. Precondition the engine before ~~For each engine duty cycle, preconditioning cycles will be needed to start the cycle average fuel mapping sequence.~~ (A) For the first and second engine duty cycle in each fuel-mapping sequence by repeating operation with the engine duty cycle with the highest reference cycle work over the relevant vehicle duty cycle. The preconditioning for the remaining cycles in the fuel-mapping sequence consists of operation over the preceding two engine duty cycles in the fuel-mapping sequence (with or without measurement). For transient vehicle duty cycles, start each engine duty cycle within 10 seconds after finishing the preceding engine duty cycle (with or without measurement). For highway cruise cycles, start each engine duty cycle and interval after linearly ramping to the speed and torque setpoints over 5 seconds and stabilizing for 15 seconds. ~~the two preconditioning cycles are the first cycle in the sequence, the transient vehicle duty cycle with the highest reference cycle work. This cycle is run twice for preconditioning prior to starting the sequence for either of the first two cycles.~~

~~(B) For all other cycles, the two preconditioning cycles are the previous two cycles in the sequence.~~

(2) If the engine has an adjustable warm idle speed setpoint, set it to ~~its minimum~~ the value defined in 40 CFR 1037.520(h)(1), $f_{idlemin}$.

(3) During each test interval, eControl speed and torque to meet the cycle validation criteria in 40 CFR 1065.514 for each interval, except that the standard error of the estimate in Table 2 of 40 CFR 1065.514 is the only speed criterion that applies if the range of reference speeds is less than 10 percent of the mean reference speed as noted in this paragraph (d)(3). For spark-ignition gaseous-fueled engines with fuel delivery at a single point in the intake manifold, you may apply the statistical criteria in Table 5 of this section for transient testing. Note that 40 CFR part 1065 does not allow reducing cycle precision to a lower frequency than subsampling of the 10 Hz GEM-generated reference cycle generated by GEM. ~~If the~~

range of reference speeds is less than 10 percent of the mean reference speed, you only need to meet the standard error of the estimate in Table 2 of 40 CFR 1065.514 for the speed regression.

Table 5 of § 1036.540—Statistical Criteria for Validating Duty Cycles for Spark-ignition Gaseous-fueled Engines

<u>Parameter</u>	<u>Speed</u>	<u>Torque</u>	<u>Power</u>
<u>Slope, a_1</u>	<u>See 40 CFR 1065.514</u>	<u>See 40 CFR 1065.514</u>	<u>See 40 CFR 1065.514</u>
<u>Absolute value of intercept, a_0</u>	<u>See 40 CFR 1065.514</u>	<u>≤ 3 % of maximum mapped torque</u>	<u>See 40 CFR 1065.514</u>
<u>Standard error of the estimate, SEE</u>	<u>See 40 CFR 1065.514</u>	<u>≤ 15 % of maximum mapped torque</u>	<u>≤ 15 % of maximum mapped power</u>
<u>Coefficient of determination, r^2</u>	<u>See 40 CFR 1065.514</u>	<u>≥ 0.700</u>	<u>≥ 0.750</u>

(4) Record measurements using direct and/or indirect measurement of fuel flow as follows:

- (i) Direct fuel-flow measurement of fuel flow. Record speed and torque and measure fuel consumption with a fuel flow meter for the ~~test~~ interval defined by the ~~first~~ engine duty cycle. ~~D~~etermine the corresponding mean values for the ~~test~~ interval. Use of redundant direct fuel-flow measurements require prior EPA approval.
- (ii) Indirect fuel-flow measurement of fuel flow. Record speed and torque and measure emissions and other inputs needed to run the chemical balance in 40 CFR 1065.655(c) for the ~~test~~ interval defined by the ~~first~~ engine duty cycle. ~~D~~etermine the corresponding mean values for the ~~test~~ interval. Use of redundant indirect fuel-flow measurements require prior EPA approval. For dilute sampling of emissions, in addition to the background measurement provisions described in 40 CFR 1065.140, you may do the following: Measure background concentration as described in 40 CFR 1065.140, except that you may use one of the following methods to apply a single background reading to multiple intervals:
 - (A) If you use batch sampling to measure background emissions, you may sample periodically into the bag over the course of multiple intervals. If you use this provision, you must apply the same background readings to correct emissions from each of the applicable intervals.
 - (B) You may determine background emissions by sampling from the dilution air over multiple engine duty cycles. If you use this provision, you must allow sufficient time for stabilization of the background measurement; followed by an averaging period of at least 30 seconds. Use the average of the two background readings to correct the measurement from each engine duty cycle. The first background reading must be taken no greater than 30 minutes before the start of the first applicable engine duty cycle and the second background reading must be taken no later than 30 minutes after the end of the last applicable engine duty cycle. Background readings may not span more than a full fuel-mapping sequence for a vehicle duty cycle.

(45) Warm up the engine as described in 40 CFR 1065.510(b)(2). Within 60 seconds after concluding the warm-up, start the linear ramp of speed and torque over 20 seconds to the first speed and torque setpoint of the preconditioning cycle. ~~Warm up the engine as described in 40 CFR 1065.510(b)(2).~~

(6) Precondition the engine before the start of testing as described in paragraph (d)(1)(iii) of this section.

~~(5) Transition between duty cycles as follows:~~

~~(i) For transient duty cycles, start the next cycle within 10 seconds after the conclusion of the preceding cycle. Note that this applies to transitioning from both the preconditioning cycles and tests for record.~~

~~(ii) For cruise cycles, linearly ramp to the next cycle over 5 seconds and stabilize for 15 seconds prior to starting the next cycle. Note that this applies to transitioning from both the preconditioning cycles and tests for record.~~

~~(6) Operate the engine over the first engine duty cycle, and record measurements using one of the methods described in (d)(6)(i) or (ii) of this section during the interval. You must also measure and report NO_x emissions over each test interval as described in paragraph (a)(2) of this section. If you use redundant systems for the determination of fuel consumption, for example combining measurements of dilute and raw emissions when generating your map, follow the requirements of 40 CFR 1065.201(d).~~

~~(i) Indirect measurement of fuel flow. Record speed and torque and measure emissions and other inputs needed to run the chemical balance in 40 CFR 1065.655(e) for the test interval defined by the first engine duty cycle; determine the corresponding mean values for the test interval. For dilute sampling of emissions, in addition to the background measurement provisions described in 40 CFR 1065.140, you may do the following:~~

~~(A) Measure background as described in § 1036.535(b)(7)(i)(A) but read the background as described in paragraph (d)(9)(i) of this section.~~

~~(B) Measure background as described in § 1036.535(b)(7)(i)(B) but read the background as described in paragraph (d)(9)(i) of this section.~~

~~(ii) Direct measurement of fuel flow. Record speed and torque and measure fuel consumption with a fuel flow meter for the test interval defined by the first engine duty cycle; determine the corresponding mean values for the test interval.~~

~~(7) Repeat the steps in paragraph (d)(6) of this section for all the remaining engine duty cycles. Continue testing engine duty cycles that are derived from the other vehicle duty cycles until testing is complete.~~

(9) You may interrupt the fuel-mapping sequence after completing any interval. You may calibrate analyzers, read and evacuate background bag samples, or sample dilution air for measuring background concentration before restarting. Shut down the engine during any interruption. If you restart the sequence within 30 minutes or less, restart the sequence at paragraph (d)(6) of this section and then restart testing at the next interval in the fuel-mapping sequence. If you restart the sequence after more than 30 minutes, restart the sequence at paragraph (d)(5) of this section and then restart testing at the next interval in the fuel-mapping sequence.

(10) The following provisions apply for infrequent regeneration events, other interruptions during intervals, and otherwise voided intervals:

(i) Stop testing if an infrequent regeneration event occurs during a interval or a interval is interrupted for any other reason. Void the interrupted interval and any additional intervals for which you are not able to meet requirements for measuring background concentration. If the infrequent regeneration event occurs between intervals, void completed intervals only if you are not able to meet requirements for measuring background concentration for those intervals. ~~(8) Repeat the steps in paragraphs (d)(4) through (7) of this section for all~~

~~the applicable groups of duty cycles (e.g., transient vehicle duty cycle, 55 mi/hr highway cruise duty cycle, and the 65 mi/hr highway cruise duty cycle).~~

~~(9) The following provisions apply for interruptions in the cycle-average fuel-mapping sequence. These provisions are intended to produce results equivalent to running the sequence without interruption.~~

~~(i) You may pause the cycle-average fuel-mapping sequence after each test interval to calibrate emission-measurement instrumentation, to read and evacuate background bag samples collected over the course of multiple test intervals, or to sample the dilution air for background emissions. This provision requires you to shut down the engine during the pause. If the pause is longer than 30 minutes, restart the engine and restart the cycle-average fuel-mapping sequence at the step in paragraph (d)(4) of this section. Otherwise, restart the engine and restart the cycle-average fuel-mapping sequence at the step in paragraph (d)(5) of this section.~~

~~(ii) If an infrequent regeneration event occurs, interrupt the cycle-average fuel-mapping sequence and allow the regeneration event to finish with the engine operating at a speed and load that allows effective regeneration.~~

~~(iii) If you interrupt testing during an interval, if you restart the sequence within 30 minutes or less, restart the sequence at paragraph (d)(6) of this section and then restart testing at the next interval in the fuel-mapping sequence. If you restart the sequence after more than 30 minutes, restart the sequence at paragraph (d)(5) of this section and then restart testing at the next interval in the fuel-mapping sequence. You may continue to operate the engine over the engine duty cycle where the event began or, using good engineering judgment, you may transition to another operating condition to reduce the regeneration event duration.~~

~~(A) Determine which cycles in the sequence to void as follows:~~

~~(1) If the regeneration event began during a test interval, the cycle associated with that test interval must be voided.~~

~~(2) If you used dilute sampling to measure emissions and you used batch sampling to measure background emissions that were sampled periodically into the bag over the course of multiple test intervals and you are unable to read the background bag (e.g., sample volume too small), void all cycles associated with that background bag.~~

~~(3) If you used dilute sampling to measure emissions and you used the option to sample periodically from the dilution air and you did not meet all the requirements for this option as described in paragraph (d)(6)(i)(B) of this section, void all cycles associated with those background readings.~~

~~(4) If the regeneration event began during a non-test interval period of the sequence and the provisions in paragraphs (d)(9)(ii)(A)(2) and (3) of this section do not apply, you do not need to void any cycles.~~

~~(B) Determine the cycle to restart the sequence. Identify the cycle associated with the last valid test interval. The next cycle in the sequence is the cycle to be used to restart the sequence.~~

~~(C) Once the regeneration event is finished, restart the sequence at the cycle determined in paragraph (d)(9)(ii)(B) of this section instead of the first cycle of the sequence. If the engine is not already warm, restart the sequence at paragraph (d)(4) of this section.~~

~~Otherwise, restart at paragraph (d)(5) of this section.~~

~~(iii) If the cycle-average fuel-mapping sequence is interrupted due to test equipment or engine malfunction, correct the malfunction and follow the steps in paragraphs (d)(9)(ii)(A) through (C) of this section to restart the sequence. Treat the detection of the malfunction as the beginning of the regeneration event.~~

~~(iv) If you void one or more intervals, you must perform additional testing to get results for all intervals. If any test interval in the cycle-average fuel-mapping sequence is voided, you must rerun that test interval as described in this paragraph (d)(9)(iv). You may rerun a complete fuel-mapping sequence the whole sequence or any contiguous part of the fuel-mapping sequence. If you get a second valid measurement for any interval, use only the result from the last valid interval. If you restart the sequence within 30 minutes or less, restart the sequence at paragraph (d)(6) of this section and then restart testing at the first selected interval in the fuel-mapping sequence. If you restart the sequence after more than 30 minutes, restart the sequence at paragraph (d)(5) of this section and then restart testing at the first selected interval in the fuel-mapping sequence. Continue testing until you have valid results for all intervals. If you end up with multiple valid test intervals for a given cycle, use the last valid test interval for determining the cycle-average fuel map. If the engine has been shut-down for more than 30 minutes or if it is not already warm, restart the sequence at paragraph (d)(4) of this section. Otherwise, restart at paragraph (d)(5) of this section. Repeat the steps in paragraphs (d)(6) and (d)(7) of this section until you complete the whole sequence or part of the sequence. The following examples illustrate possible scenarios for a partial run through a fuel-mapping completing only part of the sequence:~~

~~(A) If you voided only the test-interval associated with the fourth engine duty cycle in the sequence, you may restart the sequence using the second and third engine duty cycles as the preconditioning cycles and stop after completing the test-interval associated with the fourth engine duty cycle.~~

~~(B) If you voided the test-intervals associated with the fourth and sixth engine duty cycles, you may restart the sequence using the second and third engine duty cycles as the for preconditioning cycles and stop after completing the test-interval associated with the sixth engine duty cycle. If the test interval associated with the fifth cycle in this sequence was valid, it must be used for determining the cycle-average fuel map instead of the original one.~~

~~(110) For plug-in hybrid engines, precondition the battery and then complete all back-to-back tests for each vehicle configuration according to 40 CFR 1066.501 before moving to the next vehicle configuration.~~

~~(11) You may send signals to the engine controller during the test, such as current transmission gear and vehicle speed, if that allows engine operation during the test to better represent in-use operation.~~

~~(12) For hybrid powertrains with no plug-in capability, correct for the net energy change of the energy storage device as described in 40 CFR 1066.501. For plug-in hybrid engines, follow 40 CFR 1066.501 to determine End-of-Test for charge-depleting operation; to do this, you must get our advance approval for a utility factor curve. We will approve your utility factor curve if you can show that you created it from sufficient in-use data of vehicles in the same application as the vehicles in which the PHEV engine will be installed.~~

~~(123) Calculate the fuel mass flow rate, m_{fuel} , for each duty cycle using one of the following equations:~~

(i) Determine fuel-consumption rates using emission measurements from the raw or diluted exhaust, calculate the mass of fuel for each duty cycle, $m_{\text{fuel}[\text{cycle}]}$, as follows:

(A) For calculations that use continuous measurement of emissions and continuous CO₂ from urea, calculate $m_{\text{fuel}[\text{cycle}]}$ using the following equation:

$$m_{\text{fuel}[\text{cycle}]} = \frac{M_C}{w_{C\text{meas}}} \cdot \left(\sum_{i=1}^N \left(\dot{n}_{\text{exhi}} \cdot \frac{x_{C\text{combdry}i}}{1 + x_{\text{H}_2\text{Oexhdry}i}} \cdot \Delta t \right) - \frac{1}{M_{\text{CO}_2}} \sum_{i=1}^N (\dot{m}_{\text{CO}_2\text{DEF}i} \cdot \Delta t) \right)$$

Eq. 1036.540-3

Where:

M_C = molar mass of carbon.

$w_{C\text{meas}}$ = carbon mass fraction of fuel (or mixture of test fuels) as determined in 40 CFR 1065.655(d), except that you may not use the default properties in Table 2+ of 40 CFR 1065.655 to determine α , b , and w_C for liquid fuels. You may not account for the contribution to α , β , γ , and δ of diesel exhaust fluid or other non-fuel fluids injected into the exhaust.

i = an indexing variable that represents one recorded emission value.

N = total number of measurements over the duty cycle.

\dot{n}_{exh} = exhaust molar flow rate from which you measured emissions.

$x_{C\text{combdry}}$ = amount of carbon from fuel and any injected fluids in the exhaust per mole of dry exhaust as determined in 40 CFR 1065.655(c).

$x_{\text{H}_2\text{Oexhdry}}$ = amount of H₂O in exhaust per mole of exhaust as determined in 40 CFR 1065.655(c).

$\Delta t = 1/f_{\text{record}}$

M_{CO_2} = molar mass of carbon dioxide.

$\dot{m}_{\text{CO}_2\text{DEF}i}$ = mass emission rate of CO₂ resulting from diesel exhaust fluid decomposition over the duty cycle as determined from § 1036.535(b)(7). If your engine does not utilize diesel exhaust fluid for emission control, or if you choose not to perform this correction, set $\dot{m}_{\text{CO}_2\text{DEF}i}$ equal to 0.

Example:

$M_C = 12.0107$ g/mol

$w_{C\text{meas}} = 0.867$

$N = 6680$

$\dot{n}_{\text{exh}1} = 2.876$ mol/s

$\dot{n}_{\text{exh}2} = 2.224$ mol/s

$x_{C\text{combdry}1} = 2.61 \cdot 10^{-3}$ mol/mol

$x_{C\text{combdry}2} = 1.91 \cdot 10^{-3}$ mol/mol

$x_{\text{H}_2\text{Oexh}1} = 3.53 \cdot 10^{-2}$ mol/mol

$x_{\text{H}_2\text{Oexh}2} = 3.13 \cdot 10^{-2}$ mol/mol

$f_{\text{record}} = 10$ Hz

$t = 1/10 = 0.1$ s

$M_{\text{CO}_2} = 44.0095$ g/mol

$\dot{m}_{\text{CO}_2\text{DEF}1} = 0.0726$ g/s

$\dot{m}_{\text{CO}_2\text{DEF}2} = 0.0751$ g/s

$m_{\text{fueltransientTest}1} =$

$$\frac{12.0107}{0.867} \cdot \left(\begin{array}{l} \left(\begin{array}{l} 2.876 \cdot \frac{2.61 \cdot 10^{-3}}{1 + 3.53 \cdot 10^{-2}} \cdot 0.1 + \\ 2.224 \cdot \frac{1.91 \cdot 10^{-3}}{1 + 3.13 \cdot 10^{-2}} \cdot 0.1 + \\ \dots + \dot{n}_{\text{exh6680}} \cdot \frac{x_{\text{Ccombdry6680}}}{1 + x_{\text{H2Oexhdry6680}}} \cdot \Delta t_{6680} \end{array} \right) \\ - \frac{1}{44.0095} \cdot (0.0726 \cdot 1.0 + 0.0751 \cdot 1.0 + \dots + \dot{m}_{\text{CO2DEF6680}} \cdot \Delta t_{6680}) \end{array} \right)$$

$$m_{\text{fueltransientTest1}} = 1619.6 \text{ g}$$

(B) If you measure batch emissions and continuous CO₂ from urea, calculate $m_{\text{fuel[cycle]}}$ using the following equation:

$$m_{\text{fuel[cycle]}} = \frac{M_C}{w_{\text{Cmeas}}} \cdot \left(\frac{\bar{x}_{\text{Ccombdry}}}{1 + \bar{x}_{\text{H2Oexhdry}}} \cdot \sum_{i=1}^N (\dot{n}_{\text{exhi}} \cdot \Delta t) - \frac{1}{M_{\text{CO2}}} \sum_{i=1}^N (\dot{m}_{\text{CO2DEF}i} \cdot \Delta t) \right)$$

Eq. 1036.540-4

(C) If you measure continuous emissions and batch CO₂ from urea, calculate $m_{\text{fuel[cycle]}}$ using the following equation:

$$m_{\text{fuel[cycle]}} = \frac{M_C}{w_{\text{Cmeas}}} \cdot \left(\sum_{i=1}^N \left(\dot{n}_{\text{exhi}} \cdot \frac{x_{\text{Ccombdry}i}}{1 + x_{\text{H2Oexhdry}i}} \cdot \Delta t \right) - \frac{m_{\text{CO2DEF}}}{M_{\text{CO2}}} \right)$$

Eq. 1036.540-5

(D) If you measure batch emissions and batch CO₂ from urea, calculate $m_{\text{fuel[cycle]}}$ using the following equation:

$$m_{\text{fuel[cycle]}} = \frac{M_C}{w_{\text{Cmeas}}} \cdot \left(\frac{\bar{x}_{\text{Ccombdry}}}{1 + \bar{x}_{\text{H2Oexhdry}}} \cdot \sum_{i=1}^N (\dot{n}_{\text{exhi}} \cdot \Delta t) - \frac{m_{\text{CO2DEF}}}{M_{\text{CO2}}} \right)$$

Eq. 1036.540-6

(ii) Manufacturers may choose to measure fuel mass flow rate. Calculate the mass of fuel for each duty cycle, $m_{\text{fuel[cycle]}}$, as follows:

$$m_{\text{fuel}} = \sum_{i=1}^N \dot{m}_{\text{fuel}i} \cdot \Delta t$$

Eq. 1036.540-7

Where:

i = an indexing variable that represents one recorded value.

N = total number of measurements over the duty cycle. For batch fuel mass measurements, set $N = 1$.

$\dot{m}_{\text{fuel}i}$ = the fuel mass flow rate, for each point, i , starting from $i = 1$.

$\Delta t = 1/f_{\text{record}}$

f_{record} = the data recording frequency.

Example:

$N = 6680$

$\dot{m}_{\text{fuel}1} = 1.856 \text{ g/s}$

$\dot{m}_{\text{fuel}2} = 1.962 \text{ g/s}$

$f_{\text{record}} = 10 \text{ Hz}$

$$\Delta t = 1/10 = 0.1 \text{ s}$$

$$m_{\text{fueltransient}} = (1.856 + 1.962 + \dots + \dot{m}_{\text{fuel6680}}) \cdot 0.1$$

$$m_{\text{fueltransient}} = 111.95 \text{ g}$$

~~(134) The provisions related to carbon balance error verification in § 1036.543 apply to test intervals in this section.~~

~~(15) Correct the measured or calculated fuel mass flow rate, m_{fuel} , for each test result to a mass-specific net energy content of a reference fuel as described in § 1036.535(e), replacing \bar{m}_{fuel} with m_{fuel} in Eq. 1036.535-4.~~

~~(16) For engines designed for plug-in hybrid electric vehicles, the mass of fuel for each cycle, $m_{\text{fuel[cycle]}}$, is the utility factor weighted fuel mass. This is done by calculating m_{fuel} for the full charge-depleting and charge-sustaining portions of the test and weighting the results, using the following equation:~~

$$m_{\text{fuel[cycle],plug-in}} = m_{\text{fuel[cycle],CD}} \cdot UF_{D,CD} + m_{\text{fuel[cycle],CS}} \cdot (1 - UF_{D,CD})$$

Eq. 1036.540-8

Where:

~~$m_{\text{fuel[cycle],CD}}$ = total mass of fuel for all the tests in the charge-depleting portion of the test.~~

~~$UF_{D,CD}$ = utility factor fraction at distance D_{CD} as determined by interpolating the approved utility factor curve.~~

~~$m_{\text{fuel[cycle],CS}}$ = total mass of fuel for all the tests in the charge-sustaining portion of the test.~~

$$D_{CD} = \sum_{i=1}^N (v_i \cdot \Delta t_i)$$

Eq. 1036.540-9

Where:

~~v = vehicle velocity at each time step. For tests completed under this section, v is the vehicle velocity in the GEM duty cycle file. For tests under 40 CFR 1037.550, v is the vehicle velocity as determined by Eq. 1037.550-1. Note that this should include complete and incomplete charge-depleting tests.~~

(e) *Determine GEM inputs.* Use the results of engine testing in paragraph (d) of this section to determine the GEM inputs for the transient duty cycle and optionally for each of the highway cruise cycles corresponding to each simulated vehicle configuration as follows:

(1) Your declared fuel mass consumption, $m_{\text{fuel[cycle]}}$. Using the calculated fuel mass consumption values described in paragraph (d) of this section, declare values using the methods described in § 1036.535(g)(2) and (3).

(2) We will determine $m_{\text{fuel[cycle]}}$ values using the method described in § 1036.535(g)(3).

(3) Engine output speed per unit vehicle speed, $\left[\frac{\bar{f}_{\text{engine}}}{\bar{v}_{\text{vehicle}}} \right]_{\text{[cycle]}}$, by taking the average engine speed measured during the engine test while the vehicle is moving and dividing it by the average vehicle speed provided by GEM. Note that the engine cycle created by GEM has a flag to indicate when the vehicle is moving.

(4) Positive work determined according to 40 CFR part 1065, $W_{\text{[cycle]}}$, by using the engine speed and engine torque measured during the engine test while the vehicle is moving. Note that the engine cycle created by GEM has a flag to indicate when the vehicle is moving.

- (5) The engine idle speed and torque, by taking the average engine speed and torque measured during the engine test while the vehicle is not moving. Note that the engine cycle created by GEM has a flag to indicate when the vehicle is moving.
- (6) The following table illustrates the GEM data inputs corresponding to the different vehicle configurations for a given duty cycle:

Table 6 of § 1036.540—Example vehicle configuration test result output matrix for Class 8 vocational vehicles

	Vehicle Configuration Number								
	1	2	3	4	5	6	7	8	9
$m_{\text{fuel[cycle]}}$									
$\left[\begin{array}{c} \bar{f}_{\text{engine}} \\ \bar{v}_{\text{vehicle}} \end{array} \right]_{\text{[cycle]}}$									
$W_{\text{[cycle]}}$									
\bar{f}_{idle}^a									
\bar{T}_{idle}^a									

^aIdle speed and torque apply only for the transient duty cycle.

§ 1036.543 Carbon balance error verification.

~~The optional A-carbon balance error verification in 40 CFR 1065.543 compares independent assessments of the flow of carbon through the system (engine plus aftertreatment). We will, and you may optionally, verify carbon balance error according to 40 CFR part 1065.543. This section procedure applies to all for each individual test intervals in § 1036.535 (b), (c), and (d) and § 1036.540 and 40 CFR 1037.550.~~

Subpart G—Special Compliance Provisions

§ 1036.601 ~~What compliance provisions apply?~~ **Overview of compliance provisions.**

(a) Engine and vehicle manufacturers, as well as owners, operators, and rebuilders of engines subject to the requirements of this part, and all other persons, must observe the provisions of this part, the provisions of 40 CFR part 1068, and the provisions of the Clean Air Act. The provisions of 40 CFR part 1068 apply for heavy-duty highway engines as specified in that part, subject to the following provisions:

- (1) The exemption provisions of 40 CFR 1068.201 through 1068.230, 1068.240, and 1068.260 through 265 apply for heavy-duty motor vehicle engines. The other exemption provisions, which are specific to nonroad engines, do not apply for heavy-duty vehicles or heavy-duty engines.
- (2) ~~The tampering prohibition in 40 CFR 1068.101(b)(1) applies for alternative fuel conversions as specified in 40 CFR part 85, subpart F.~~ **Engine signals to indicate a need for maintenance under §1036.125(a)(1)(ii) are considered an element of design of the emission control system. Disabling, resetting, or otherwise rendering such signals inoperative without also performing the indicated maintenance procedure is therefore prohibited under 40 CFR 1068.101(b)(1).**
- (3) The warranty-related prohibitions in section 203(a)(4) of the Act (42 U.S.C. 7522(a)(4)) apply to manufacturers of new heavy-duty highway engines in addition to the prohibitions

described in 40 CFR 1068.101(b)(6). We may assess a civil penalty up to \$44,539 for each engine or vehicle in violation.

(b) The following provisions from 40 CFR parts 85 and 86 continue to apply after model year 2026 for engines subject to the requirements of this part:

(1) The tampering prohibition in 40 CFR 1068.101(b)(1) applies for alternative fuel conversions as specified in 40 CFR part 85, subpart F.

(2) Engine manufacturers must meet service information requirements as specified in 40 CFR 86.010-38(j). ~~Engines exempted from the applicable standards of 40 CFR part 86 under the provisions of 40 CFR part 1068 are exempt from the standards of this part without request.~~

(3) Provisions related to nonconformance penalties apply as described in 40 CFR part 86, subpart L.

(4) The manufacturer-run in-use testing program applies as described in 40 CFR part 86, subpart T.

(c) The emergency vehicle field modification provisions of 40 CFR 85.1716 apply with respect to the standards of this part.

(d) Subpart C of this part describes how to test and certify dual-fuel and flexible-fuel engines. Some multi-fuel engines may not fit either of those defined terms. For such engines, we will determine whether it is most appropriate to treat them as single-fuel engines, dual-fuel engines, or flexible-fuel engines based on the range of possible and expected fuel mixtures. For example, an engine might burn natural gas but initiate combustion with a pilot injection of diesel fuel. If the engine is designed to operate with a single fueling algorithm (i.e., fueling rates are fixed at a given engine speed and load condition), we would generally treat it as a single-fuel engine. In this context, the combination of diesel fuel and natural gas would be its own fuel type. If the engine is designed to also operate on diesel fuel alone, we would generally treat it as a dual-fuel engine. If the engine is designed to operate on varying mixtures of the two fuels, we would generally treat it as a flexible-fuel engine. To the extent that requirements vary for the different fuels or fuel mixtures, we may apply the more stringent requirements.

§ 1036.605 ~~GHG exemption~~ Alternate emission standards for engines used in specialty vehicles.

~~Engines certified to the alternative standards specified in 40 CFR 86.007-11 and 86.008-10 for use in specialty vehicles as described in 40 CFR 1037.605 are exempt from the standards of this part. See 40 CFR part 1037 for provisions that apply to the vehicle. Starting in model year 2027,~~ compression-ignition engines at or above 56 kW and spark-ignition engines of any size that will be installed in specialty vehicles as allowed by 40 CFR 1037.605 are exempt from the standards of subpart B this part. Qualifying engines must certify under this part by meeting alternate emission standards as follows:

(a) Spark-ignition engines must be of a configuration that is identical to one that is certified under 40 CFR part 1048 to Blue Sky standards under 40 CFR 1048.140.

(b) Compression-ignition engines must be of a configuration that is identical to one that is certified under 40 CFR part 1039, and meet the following additional standards using the same duty cycles that apply under 40 CFR part 1039:

(1) The engines must be certified with a Family Emission Limit for PM of 0.020 g/kW-hr.

(2) Diesel-fueled engines using selective catalytic reduction must meet an emission standard of 0.1 g/kW-hr for N₂O.

(c) Except as specified in this section, engines certified under this section must meet all the requirements that apply under 40 CFR part 1039 or 1048 instead of the comparable provisions in

this part. Before shipping engines under this section, you must have written assurance from vehicle manufacturers that they need a certain number of exempted engines under this section. In your annual production report under 40 CFR 1039.250 or 1048.250, count these engines separately and identify the vehicle manufacturers that will be installing them. Treat these engines as part of the corresponding engine family under 40 CFR part 1039 or part 1048 for compliance purposes such as testing production engines, in-use testing, defect reporting, and recall.

(d) The engines must be labeled as described in §1036.135, with the following statement instead of the one specified in § 1036.135(c)(8): “This engine conforms to alternate standards for specialty vehicles under 40 CFR 1036.605.” Engines certified under this section may not have the label specified for nonroad engines in 40 CFR part 1039 or part 1048 or any other label identifying them as nonroad engines.

(e) In a separate application for a certificate of conformity, identify the corresponding nonroad engine family, describe the label required under section, state that you meet applicable diagnostic requirements under 40 CFR part 1039 or part 1048, and identify your projected U.S.-directed production volume.

(f) No additional certification fee applies for engines certified under this section.

(g) Engines certified under this section may not generate or use emission credits under this part or under 40 CFR part 1039. The vehicles in which these engines are installed may generate or use emission credits as described in 40 CFR part 1037.

§ 1036.610 Off-cycle technology credits and adjustments for reducing greenhouse gas emissions.

(a) You may ask us to apply the provisions of this section for CO₂ emission reductions resulting from powertrain technologies that were not in common use with heavy-duty vehicles before model year 2010 that are not reflected in the specified ~~test~~ procedure. While you are not required to prove that such technologies were not in common use with heavy-duty vehicles before model year 2010, we will not approve your request if we determine that they do not qualify. We will apply these provisions only for technologies that will result in a measurable, demonstrable, and verifiable real-world CO₂ reduction. Note that prior to model year 2016, these technologies were referred to as “innovative technologies”.

(b) The provisions of this section may be applied as either an improvement factor (used to adjust emission results) or as a separate credit, consistent with good engineering judgment. Note that the term “credit” in this section describes an additive adjustment to emission rates and is not equivalent to an emission credit in the ABT program of subpart H of this part. We recommend that you base your credit/adjustment on A to B testing of pairs of engines/vehicles differing only with respect to the technology in question.

(1) Calculate improvement factors as the ratio of in-use emissions with the technology divided by the in-use emissions without the technology. Adjust the emission results by multiplying by the improvement factor. Use the improvement-factor approach where good engineering judgment indicates that the actual benefit will be proportional to emissions measured over the ~~test~~ procedures specified in this part. For example, the benefits from technologies that reduce engine operation would generally be proportional to the engine’s emission rate.

(2) Calculate separate credits based on the difference between the in-use emission rate (g/ton-mile) with the technology and the in-use emission rate without the technology. Subtract this value from your measured emission result and use this adjusted value to determine your FEL. We may also allow you to calculate the credits based on g/hp-hr emission rates. Use the

separate-credit approach where good engineering judgment indicates that the actual benefit will not be proportional to emissions measured over the ~~test~~ procedures specified in this part.

(3) We may require you to discount or otherwise adjust your improvement factor or credit to account for uncertainty or other relevant factors.

(c) Send your request to the Designated Compliance Officer. We recommend that you do not begin collecting ~~test~~ data (for submission to EPA) before contacting us. For technologies for which the vehicle manufacturer could also claim credits (such as transmissions in certain circumstances), we may require you to include a letter from the vehicle manufacturer stating that it will not seek credits for the same technology. Your request must contain the following items:

(1) A detailed description of the off-cycle technology and how it functions to reduce CO₂ emissions under conditions not represented on the duty cycles required for certification.

(2) A list of the engine configurations that will be equipped with the technology.

(3) A detailed description and justification of the selected ~~test~~ engines.

(4) All testing and simulation data required under this section, plus any other data you have considered in your analysis. You may ask for our preliminary approval of your ~~test~~ plan under § 1036.210.

(5) A complete description of the methodology used to estimate the off-cycle benefit of the technology and all supporting data, including engine testing and in-use activity data. Also include a statement regarding your recommendation for applying the provisions of this section for the given technology as an improvement factor or a credit.

(6) An estimate of the off-cycle benefit by engine model, and the fleetwide benefit based on projected sales of engine models equipped with the technology.

(7) A demonstration of the in-use durability of the off-cycle technology, based on any available engineering analysis or durability testing data (either by testing components or whole engines).

(d) We may seek public comment on your request, consistent with the provisions of 40 CFR 86.1869-12(d). However, we will generally not seek public comment on credits/adjustments based on A to B engine dynamometer testing, chassis testing, or in-use testing.

(e) We may approve an improvement factor or credit for any configuration that is properly represented by your testing.

(1) For model years before 2021, you may continue to use an approved improvement factor or credit for any appropriate engine families in future model years through 2020.

(2) For model years 2021 and later, you may not rely on an approval for model years before 2021. You must separately request our approval before applying an improvement factor or credit under this section for 2021 and later engines, even if we approved an improvement factor or credit for similar engine models before model year 2021. Note that approvals for model year 2021 and later may carry over for multiple years.

§ 1036.615 Engines with Rankine cycle waste heat recovery and hybrid powertrains.

This section specifies how to generate advanced-technology emission credits for hybrid powertrains that include energy storage systems and regenerative braking (including regenerative engine braking) and for engines that include Rankine-cycle (or other bottoming cycle) exhaust energy recovery systems. This section applies only for model year 2020 and earlier engines.

(a) *Pre-transmission hybrid powertrains.* Test pre-transmission hybrid powertrains with the hybrid engine ~~test~~ procedures of 40 CFR part 1065 or with the post-transmission ~~test~~ procedures in 40 CFR 1037.550. Pre-transmission hybrid powertrains are those engine systems that include features to recover and store energy during engine motoring operation but not from the vehicle's

wheels. Engines certified with pre-transmission hybrid powertrains must be certified to meet the diagnostic requirements ~~of 40 CFR 86.018-10~~ as specified in §1036.110 with respect to powertrain components and systems; if different manufacturers produce the engine and the hybrid powertrain, the hybrid powertrain manufacturer may separately certify its powertrain relative to diagnostic requirements.

(b) *Rankine engines.* Test engines that include Rankine-cycle exhaust energy recovery systems according to the ~~test~~ procedures specified in subpart F of this part unless we approve alternate procedures.

(c) *Calculating credits.* Calculate credits as specified in subpart H of this part. Credits generated from engines and powertrains certified under this section may be used in other averaging sets as described in § 1036.740(c).

(d) *Off-cycle technologies.* You may certify using both the provisions of this section and the off-cycle technology provisions of § 1036.610, provided you do not double-count emission benefits.

§ 1036.620 Alternate CO₂ standards based on model year 2011 compression-ignition engines.

For model years 2014 through 2016, you may certify your compression-ignition engines to the CO₂ standards of this section instead of the CO₂ standards in § 1036.108. However, you may not certify engines to these alternate standards if they are part of an averaging set in which you carry a balance of banked credits. You may submit applications for certifications before using up banked credits in the averaging set, but such certificates will not become effective until you have used up (or retired) your banked credits in the averaging set. For purposes of this section, you are deemed to carry credits in an averaging set if you carry credits from advanced technology that are allowed to be used in that averaging set.

(a) The standards of this section are determined from the measured emission rate of the ~~test~~ engine of the applicable baseline 2011 engine family or families as described in paragraphs (b) and (c) of this section. Calculate the CO₂ emission rate of the baseline ~~test~~ engine using the same equations used for showing compliance with the otherwise applicable standard. The alternate CO₂ standard for light and medium heavy-duty vocational-certified engines (certified for CO₂ using the transient cycle) is equal to the baseline emission rate multiplied by 0.975. The alternate CO₂ standard for tractor-certified engines (certified for CO₂ using the SET duty cycle) and all other ~~Hheavy HDEheavy-duty engines~~ is equal to the baseline emission rate multiplied by 0.970. The in-use FEL for these engines is equal to the alternate standard multiplied by 1.03.

(b) This paragraph (b) applies if you do not certify all your engine families in the averaging set to the alternate standards of this section. Identify separate baseline engine families for each engine family that you are certifying to the alternate standards of this section. For an engine family to be considered the baseline engine family, it must meet the following criteria:

(1) It must have been certified to all applicable emission standards in model year 2011. If the baseline engine was certified to a NO_x FEL above the standard and incorporated the same emission control technologies as the new engine family, you may adjust the baseline CO₂ emission rate to be equivalent to an engine meeting the 0.20 g/hp_{-hr} NO_x standard (or your higher FEL as specified in this paragraph (b)(1)), using certification results from model years 2009 through 2011, consistent with good engineering judgment.

(i) Use the following equation to relate model year 2009-2011 NO_x and CO₂ emission rates (g/hp_{-hr}): $CO_2 = a \times \log(NO_x) + b$.

(ii) For model year 2014-2016 engines certified to NO_x FELs above 0.20 g/hp_{-hr}, correct the baseline CO₂ emissions to the actual NO_x FELs of the 2014-2016 engines.

(iii) Calculate separate adjustments for emissions over the SET duty cycle and the transient cycle.

(2) The baseline configuration tested for certification must have the same engine displacement as the engines in the engine family being certified to the alternate standards, and its rated power must be within five percent of the highest rated power in the engine family being certified to the alternate standards.

(3) The model year 2011 U.S.-directed production volume of the configuration tested must be at least one percent of the total 2011 U.S.-directed production volume for the engine family.

(4) The tested configuration must have cycle-weighted BSFC equivalent to or better than all other configurations in the engine family.

(c) This paragraph (c) applies if you certify all your engine families in the primary intended service class to the alternate standards of this section. For purposes of this section, you may combine **L**ight ~~HDEheavy-duty~~ and **M**edium ~~HDEheavy-duty engines~~ into a single averaging set. Determine your baseline CO₂ emission rate as the production-weighted emission rate of the certified engine families you produced in the 2011 model year. If you produce engines for both tractors and vocational vehicles, treat them as separate averaging sets. Adjust the CO₂ emission rates to be equivalent to an engine meeting the average NO_x FEL of new engines (assuming engines certified to the 0.20 g/hp_{-hr} NO_x standard have a NO_x FEL equal to 0.20 g/hp_{-hr}), as described in paragraph (b)(1) of this section.

(d) Include the following statement on the emission control information label: “THIS ENGINE WAS CERTIFIED TO AN ALTERNATE CO₂ STANDARD UNDER § 1036.620.”

(e) You may not bank CO₂ emission credits for any engine family in the same averaging set and model year in which you certify engines to the standards of this section. You may not bank any advanced-technology credits in any averaging set for the model year you certify under this section (since such credits would be available for use in this averaging set). Note that the provisions of § 1036.745 apply for deficits generated with respect to the standards of this section.

(f) You need our approval before you may certify engines under this section, especially with respect to the numerical value of the alternate standards. We will not approve your request if we determine that you manipulated your engine families or ~~test~~-engine configurations to certify to less stringent standards, or that you otherwise have not acted in good faith. You must keep and provide to us any information we need to determine that your engine families meet the requirements of this section. Keep these records for at least five years after you stop producing engines certified under this section.

§ 1036.625 In-use compliance with CO₂ family emission limits (FELs).

Section 1036.225 describes how to change the FEL for an engine family during the model year. This section, which describes how you may ask us to increase an engine family’s CO₂ FEL after the end of the model year, is intended to address circumstances in which it is in the public interest to apply a higher in-use CO₂ FEL based on forfeiting an appropriate number of emission credits. For example, this may be appropriate where we determine that recalling vehicles would not significantly reduce in-use emissions. We will generally not allow this option where we determine the credits being forfeited would likely have expired.

(a) You may ask us to increase an engine family’s FEL after the end of the model year if you believe some of your in-use engines exceed the CO₂ FEL that applied during the model year (or the CO₂ emission standard if the family did not generate or use emission credits). We may consider any available information in making our decision to approve or deny your request.

(b) If we approve your request under this section, you must apply emission credits to cover the increased FEL for all affected engines. Apply the emission credits as part of your credit demonstration for the current production year. Include the appropriate calculations in your final report under § 1036.730.

(c) Submit your request to the Designated Compliance Officer. Include the following in your request:

- (1) Identify the names of each engine family that is the subject of your request. Include separate family names for different model years
- (2) Describe why your request does not apply for similar engine models or additional model years, as applicable.
- (3) Identify the FEL(s) that applied during the model year and recommend a replacement FEL for in-use engines; include a supporting rationale to describe how you determined the recommended replacement FEL.
- (4) Describe whether the needed emission credits will come from averaging, banking, or trading.

(d) If we approve your request, we will identify the replacement FEL. The value we select will reflect our best judgment to accurately reflect the actual in-use performance of your engines, consistent with the testing provisions specified in this part. We may apply the higher FELs to other engine families from the same or different model years to the extent they used equivalent emission controls. We may include any appropriate conditions with our approval.

(e) If we order a recall for an engine family under 40 CFR 1068.505, we will no longer approve a replacement FEL under this section for any of your engines from that engine family, or from any other engine family that relies on equivalent emission controls.

§ 1036.630 Certification of engine ~~GHG~~greenhouse gas emissions for powertrain testing.

For engines included in powertrain families under 40 CFR part 1037, you may choose to include the corresponding engine emissions in your engine families under this part ~~1036~~ instead of (or in addition to) the otherwise applicable engine fuel maps.

(a) If you choose to certify powertrain fuel maps in an engine family, the declared powertrain emission levels become standards that apply for selective enforcement audits and in-use testing. We may require that you provide to us the engine ~~test~~ cycle (not normalized) corresponding to a given powertrain for each of the specified duty cycles.

(b) If you choose to certify only fuel map emissions for an engine family and to not certify emissions over powertrain ~~test~~ cycles under 40 CFR 1037.550, we will not presume you are responsible for emissions over the powertrain cycles. However, where we determine that you are responsible in whole or in part for the emission exceedance in such cases, we may require that you participate in any recall of the affected vehicles. Note that this provision to limit your responsibility does not apply if you also hold the certificate of conformity for the vehicle.

(c) If you split an engine family into subfamilies based on different fuel-mapping procedures as described in § 1036.230(e), the fuel-mapping procedures you identify for certifying each subfamily also apply for selective enforcement audits and in-use testing.

§ 1036.635—[Reserved]

§ 1036.655 Special provisions for diesel-fueled engines sold in American Samoa or the

Commonwealth of the Northern Mariana Islands.

(a) The prohibitions in §1068.101(a)(1) do not apply to diesel-fueled engines, subject to the following conditions:

(1) The engine is intended for use and will be used in American Samoa or the Commonwealth of the Northern Mariana Islands.

(2) The engine meets the emission standards that applied to model year 2006 engines as specified in appendix A of this part.

(3) You meet all the requirements of 40 CFR 1068.265.

(b) If you introduce an engine into U.S. commerce under this section, you must meet the labeling requirements in §1036.135, but add the following statement instead of the compliance statement in §1039.135(c)(12):

THIS ENGINE (or VEHICLE, as applicable) CONFORMS TO US EPA EMISSION STANDARDS APPLICABLE TO MODEL YEAR 2006. THIS ENGINE (or VEHICLE, as applicable) DOES NOT CONFORM TO US EPA EMISSION REQUIREMENTS IN EFFECT AT TIME OF PRODUCTION AND MAY NOT BE IMPORTED INTO THE UNITED STATES OR ANY TERRITORY OF THE UNITED STATES EXCEPT AMERICAN SAMOA OR THE COMMONWEALTH OF THE NORTHERN MARIANA ISLANDS.

(c) Introducing into U.S. commerce an engine exempted under this section in any state or territory of the United States other than American Samoa or the Commonwealth of the Northern Mariana Islands, throughout its lifetime, violates the prohibitions in 40 CFR 1068.101(a)(1), unless it is exempt under a different provision.

(d) The exemption provisions in this section also applied for model year 2007 and later engines introduced into commerce in Guam before [INSERT DATE 30 DAYS AFTER DATE OF PUBLICATION IN THE FEDERAL REGISTER].

Subpart H—Averaging, Banking, and Trading for Certification

§ 1036.701 General provisions.

(a) You may average, bank, and trade (ABT) emission credits for purposes of certification as described in this subpart and in subpart B of this part to show compliance with the standards of §§ 1036.104 and 1036.108. Participation in this program is voluntary. Note that certification to NO_x standards in §1036.104 is based on a Family Emission Limit (FEL) and certification to CO₂ standards in §1036.108 is based on a Family Certification Level (FCL). This subpart refers to “FEL/FCL” to simultaneously refer to FELs for NO_x and FCLs for CO₂. (Note also that ~~As described in~~ subpart B of this part requires, you ~~to must~~ assign an FCL to all engine families, whether or not they participate in the ABT provisions of this subpart.)

(b) The definitions of subpart I of this part apply to this subpart in addition to the following definitions:

(1) *Actual emission credits* means emission credits you have generated that we have verified by reviewing your final report.

(2) *Averaging set* means a set of engines in which emission credits may be exchanged. See § 1036.740.

(3) *Broker* means any entity that facilitates a trade of emission credits between a buyer and seller.

(4) *Buyer* means the entity that receives emission credits as a result of a trade.

- (5) *Reserved emission credits* means emission credits you have generated that we have not yet verified by reviewing your final report.
- (6) *Seller* means the entity that provides emission credits during a trade.
- (7) *Standard* means the emission standard that applies under subpart B of this part for engines not participating in the ABT program of this subpart.
- (8) *Trade* means to exchange emission credits, either as a buyer or seller.
- (c) Emission credits may be exchanged only within an averaging set, except as specified in § 1036.740.
- (d) You may not use emission credits generated under this subpart to offset any emissions that exceed an FEL/FCL or standard. This paragraph (d) applies for all testing, including certification testing, in-use testing, selective enforcement audits, and other production-line testing. However, if emissions from an engine exceed an FEL/FCL or standard (for example, during a selective enforcement audit), you may use emission credits to recertify the engine family with a higher FEL/FCL that applies only to future production.
- (e) You may use either of the following approaches to retire or forego emission credits:
- (1) You may retire emission credits generated from any number of your engines. This may be considered donating emission credits to the environment. Identify any such credits in the reports described in § 1036.730. Engines must comply with the applicable FELs even if you donate or sell the corresponding emission credits under this paragraph (h). Those credits may no longer be used by anyone to demonstrate compliance with any EPA emission standards.
 - (2) You may certify an engine family using an FEL (~~FCL for CO₂~~)/FCL below the emission standard as described in this part and choose not to generate emission credits for that family. If you do this, you do not need to calculate emission credits for those engine families, and you do not need to submit or keep the associated records described in this subpart for that family.
- (f) Emission credits may be used in the model year they are generated. Surplus emission credits may be banked for future model years. Surplus emission credits may sometimes be used for past model years, as described in § 1036.745.
- (g) You may increase or decrease an FEL/FCL during the model year by amending your application for certification under § 1036.225. The new FEL/FCL may apply only to engines you have not already introduced into commerce.
- (h) See § 1036.740 for special credit provisions that apply for greenhouse gas credits generated under 40 CFR 86.1819-14(k)(7) or § 1036.615 or 40 CFR 1037.615.
- (i) Unless the regulations in this part explicitly allow it, you may not calculate Phase 1 credits more than once for any emission reduction. For example, if you generate Phase 1 CO₂ emission credits for a hybrid engine under this part for a given vehicle, no one may generate CO₂ emission credits for that same hybrid engine and the associated vehicle under 40 CFR part 1037. However, Phase 1 credits could be generated for identical vehicles using engines that did not generate credits under this part.
- (j) Credits you generate with compression-ignition engines in 2020 and earlier model years may be used in model year 2021 and later as follows:
- (1) For credit-generating engines certified to the tractor engine standards in § 1036.108, you may use credits calculated relative to the tractor engine standards.

(2) For credit-generating engines certified to the vocational engine standards in § 1036.108, you may optionally carry over adjusted vocational credits from an averaging set, and you may use credits calculated relative to the emission levels in the following table:

Table 1 of §1036.701—Emission Levels for Credit Calculation

Medium Heavy-Duty Engines	Heavy Heavy-Duty Engines
558 g/hp·hr	525 g/hp·hr

(k) Engine families you certify with a nonconformance penalty under 40 CFR part 86, subpart L, may not generate emission credits.

§ 1036.705 Generating and calculating emission credits.

(a) The provisions of this section apply separately for calculating emission credits for each pollutant.

(b) For each participating family, calculate positive or negative emission credits relative to the otherwise applicable emission standard ~~based on the engine family’s FCL for greenhouse gases. If your engine family is certified to both the vocational and tractor engine standards, calculate credits separately for the vocational engines and the tractor engines (as specified in paragraph (b)(3) of this section).~~ Calculate positive emission credits for a family that has an FEL/FCL below the standard. Calculate negative emission credits for a family that has an FEL/FCL above the standard. Sum your positive and negative credits for the model year before rounding.

(1) Calculate emission credits ~~Round the sum of emission credits~~ to the nearest megagram (Mg); for each family or subfamily using ~~consistent units throughout~~ the following equations:

(1) For vocational engines:

$$Emission\ credits\ (Mg) = (Std - FCL) \cdot (CF) \cdot (Volume) \cdot (UL) \cdot c \cdot (10^{-6})$$

Eq. 1036.705-1

Where:

Std = the emission standard, in (mg NO_x)/hp·hr or (g CO₂)/hp·hr, that applies under subpart B of this part for engines not participating in the ABT program of this subpart (the “otherwise applicable standard”).

FCL = the engine family’s FEL for NO_x, in mg/hp·hr, and FCL for CO₂ Family Certification Level for the engine family, in g/hp·hr, ~~measured over the transient duty cycle,~~ rounded to the same number of decimal places as the emission standard.

CF = a transient cycle conversion factor (hp·hr/mile), calculated by dividing the total (integrated) horsepower-hour over the applicable duty cycle ~~(average of vocational engine configurations weighted by their production volumes)~~ by 6.3 miles for engines subject to spark-ignition standards and 6.5 miles for engines subject to compression-ignition standards. This represents the average work performed by vocational engines in the family over the mileage represented by operation over the duty cycle. See paragraph (b)(3) for provisions that apply for CO₂.

Volume = the number of ~~vocational~~ engines eligible to participate in the averaging, banking, and trading program within the given engine family or subfamily during the model year, as described in paragraph (c) of this section.

UL = the useful life for the standard that applies for a given engine family primary intended service class, in miles.

c = use 10⁻⁶ for CO₂ and 10⁻⁹ for NO_x.

Example for model year 2025 Heavy HDE generating CO₂ credits for a model year 2028

Heavy HDE:

Std = 432 g/hp·hr

FL = 401 g/hp·hr

CF = 9.78 hp·hr/mile

Volume = 15,342

UL = 435,000 miles

c = 10⁻⁶

Emission credits = (432 – 401) · 9.78 · 15,342 · 435,000 · 10⁻⁶ = 28,131,142 Mg

(2) [Reserved] For tractor engines:

$Emission\ credits\ (Mg) = (Std - FCL) \cdot (CF) \cdot (Volume) \cdot (UL) \cdot (10^{-6})$

Where:

Std = the emission standard, in g/hp·hr, that applies under subpart B of this part for engines not participating in the ABT program of this subpart (the “otherwise applicable standard”).

FCL = the Family Certification Level for the engine family, in g/hp·hr, measured over the SET duty cycle rounded to the same number of decimal places as the emission standard.

CF = a transient cycle conversion factor (hp·hr/mile), calculated by dividing the total (integrated) horsepower hour over the duty cycle (average of tractor engine configurations weighted by their production volumes) by 6.3 miles for engines subject to spark ignition standards and 6.5 miles for engines subject to compression ignition standards. This represents the average work performed by tractor engines in the family over the mileage represented by operation over the duty cycle. Note that this calculation requires you to use the transient cycle conversion factor even for engines certified to standards based on the SET duty cycle.

Volume = the number of tractor engines eligible to participate in the averaging, banking, and trading program within the given engine family during the model year, as described in paragraph (c) of this section.

UL = the useful life for the given engine family, in miles.

(3) The following additional provisions apply for calculating CO₂ credits:

(i) For engine families certified to both the vocational and tractor engine standards, calculate credits separately for the vocational engines and the tractor engines. We may allow you to use statistical methods to estimate the total production volumes where a small fraction of the engines cannot be tracked precisely.

(ii) Calculate the transient cycle conversion factor for vocational engines based on the average of vocational engine configurations weighted by their production volumes. Similarly, calculate the transient cycle conversion factor for tractor engines based on the average of tractor engine configurations weighted by their production volumes. Note that calculating the transient cycle conversion factor for tractors requires you to use the conversion factor even for engines certified to standards based on the SET duty cycle.

(iii) The FCL for CO₂ is based on measurement over the FTP duty cycle for vocational engines and over the SET duty cycle for tractor engines.

(4) You may not generate emission credits for tractor engines (i.e., engines not certified to the transient cycle for CO₂) installed in vocational vehicles (including vocational tractors certified under 40 CFR 1037.630 or exempted under 40 CFR 1037.631). We will waive this provision where you demonstrate that less than five percent of the engines in your tractor

family were installed in vocational vehicles. For example, if you know that 96 percent of your tractor engines were installed in non-vocational tractors, but cannot determine the vehicle type for the remaining four percent, you may generate credits for all the engines in the family.

(5) You may generate CO₂ emission credits from a model year 2021 or later medium heavy-duty engine family subject to spark-ignition standards for exchanging with other engine families only if the engines in the family are gasoline-fueled. You may generate CO₂ credits from non-gasoline engine families only for the purpose of offsetting CH₄ and/or N₂O emissions within the same engine family as described in paragraph (d) of this section.

(c) As described in § 1036.730, compliance with the requirements of this subpart is determined at the end of the model year based on actual U.S.-directed production volumes. Keep appropriate records to document these production volumes. Do not include any of the following engines to calculate emission credits:

(1) Engines that you do not certify to the CO₂ standards of this part because they are permanently exempted under subpart G of this part or under 40 CFR part 1068.

(2) Exported engines.

(3) Engines not subject to the requirements of this part, such as those excluded under § 1036.5. For example, do not include engines used in vehicles certified to the greenhouse gas standards of 40 CFR 86.1819.

(4) Any other engines if we indicate elsewhere in this part ~~1036~~ that they are not to be included in the calculations of this subpart.

(d) You may use CO₂ emission credits to show compliance with CH₄ and/or N₂O FELs instead of the otherwise applicable emission standards. To do this, calculate the CH₄ and/or N₂O emission credits needed (negative credits) using the equation in paragraph (b) of this section, using the FEL(s) you specify for your engines during certification instead of the FCL. You must use 34 Mg of positive CO₂ credits to offset 1 Mg of negative CH₄ credits for model year 2021 and later engines, and you must use 25 Mg of positive CO₂ credits to offset 1 Mg of negative CH₄ credits for earlier engines. You must use 298 Mg of positive CO₂ credits to offset 1 Mg of negative N₂O credits.

§ 1036.710 Averaging.

(a) Averaging is the exchange of emission credits among your engine families. You may average emission credits only within the same averaging set, except as specified in § 1036.740.

(b) You may certify one or more engine families to an FEL/FCL above the applicable standard, subject to any applicable FEL caps and other the provisions in subpart B of this part, if you show in your application for certification that your projected balance of all emission-credit transactions in that model year is greater than or equal to zero, or that a negative balance is allowed under § 1036.745.

(c) If you certify an engine family to an FEL/FCL that exceeds the otherwise applicable standard, you must obtain enough emission credits to offset the engine family's deficit by the due date for the final report required in § 1036.730. The emission credits used to address the deficit may come from your other engine families that generate emission credits in the same model year (or from later model years as specified in § 1036.745), from emission credits you have banked, or from emission credits you obtain through trading.

§ 1036.715 Banking.

- (a) Banking is the retention of surplus emission credits by the manufacturer generating the emission credits for use in future model years for averaging or trading.
- (b) You may designate any emission credits you plan to bank in the reports you submit under § 1036.730 as reserved credits. During the model year and before the due date for the final report, you may designate your reserved emission credits for averaging or trading.
- (c) Reserved credits become actual emission credits when you submit your final report. However, we may revoke these emission credits if we are unable to verify them after reviewing your reports or auditing your records.
- (d) Banked credits retain the designation of the averaging set in which they were generated.

§ 1036.720 Trading.

- (a) Trading is the exchange of emission credits between manufacturers. You may use traded emission credits for averaging, banking, or further trading transactions. Traded emission credits remain subject to the averaging-set restrictions based on the averaging set in which they were generated.
- (b) You may trade actual emission credits as described in this subpart. You may also trade reserved emission credits, but we may revoke these emission credits based on our review of your records or reports or those of the company with which you traded emission credits. You may trade banked credits within an averaging set to any certifying manufacturer.
- (c) If a negative emission credit balance results from a transaction, both the buyer and seller are liable, except in cases we deem to involve fraud. See § 1036.255(e) for cases involving fraud. We may void the certificates of all engine families participating in a trade that results in a manufacturer having a negative balance of emission credits. See § 1036.745.

§ 1036.725 ~~What must I include in my application for certification?~~ **Required information for certification.**

- (a) You must declare in your application for certification your intent to use the provisions of this subpart for each engine family that will be certified using the ABT program. You must also declare the FELs/FCL you select for the engine family for each pollutant for which you are using the ABT program. Your FELs must comply with the specifications of subpart B of this part, including the FEL caps. ~~FELs/FCLs must be expressed to the same number of decimal places as the applicable standards.~~
- (b) Include the following in your application for certification:
 - (1) A statement that, to the best of your belief, you will not have a negative balance of emission credits for any averaging set when all emission credits are calculated at the end of the year; or a statement that you will have a negative balance of emission credits for one or more averaging sets, but that it is allowed under § 1036.745.
 - (2) Detailed calculations of projected emission credits (positive or negative) based on projected U.S.-directed production volumes. We may require you to include similar calculations from your other engine families to project your net credit balances for the model year. If you project negative emission credits for a family, state the source of positive emission credits you expect to use to offset the negative emission credits.

§ 1036.730 ABT reports.

- (a) If **you certify** any of your engine families ~~are certified~~ using the ABT provisions of this subpart, you must send **us an end-of-year report by March 31 following the end of the model**

~~year and~~ a final report by September 30 following the end of the model year. ~~We may waive the requirement to send an end-of-year report.~~

(b) Your ~~end-of-year and final~~ reports must include the following information for each engine family participating in the ABT program:

- (1) Engine-family designation and averaging set.
- (2) The emission standards that would otherwise apply to the engine family.
- (3) The FEL/FCL for each pollutant. If you change the FEL/FCL after the start of production, identify the date that you started using the new FEL/FCL and/or give the engine identification number for the first engine covered by the new FEL/FCL. In this case, identify each applicable FEL/FCL and calculate the positive or negative emission credits as specified in §1036.225.
- (4) The projected and actual U.S.-directed production volumes for the model year. If you changed an FEL/FCL during the model year, identify the actual U.S.-directed production volume associated with each FEL/FCL.
- (5) The transient cycle conversion factor for each engine configuration as described in § 1036.705.
- (6) Useful life.
- (7) Calculated positive or negative emission credits for the whole engine family. Identify any emission credits that you traded, as described in paragraph (d)(1) of this section.

(c) Your ~~end-of-year and final~~ reports must include the following additional information:

- (1) Show that your net balance of emission credits from all your participating engine families in each averaging set in the applicable model year is not negative, except as allowed under § 1036.745. Your credit tracking must account for the limitation on credit life under § 1036.740(d).
- (2) State whether you will reserve any emission credits for banking.
- (3) State that the report's contents are accurate.

(d) If you trade emission credits, you must send us a report within 90 days after the transaction, as follows:

- (1) As the seller, you must include the following information in your report:
 - (i) The corporate names of the buyer and any brokers.
 - (ii) A copy of any contracts related to the trade.
 - (iii) The averaging set corresponding to the engine families that generated emission credits for the trade, including the number of emission credits from each averaging set.
- (2) As the buyer, you must include the following information in your report:
 - (i) The corporate names of the seller and any brokers.
 - (ii) A copy of any contracts related to the trade.
 - (iii) How you intend to use the emission credits, including the number of emission credits you intend to apply for each averaging set.

(e) Send your reports electronically to the Designated Compliance Officer using an approved information format. If you want to use a different format, send us a written request with justification for a waiver.

(f) Correct errors in your ~~end-of-year or final~~ report as follows:

(1) ~~You may correct any errors in your end-of-year report when you prepare the final report, as long as you send us the final report by the time it is due.~~

~~(2)~~ If you or we determine by September 30 ~~within 270 days~~ after the end of the model year that errors mistakenly decreased your balance of emission credits, you may correct the errors

and recalculate the balance of emission credits. You may not make these corrections for errors that are determined ~~later than September 30~~ ~~more than 270 days~~ after the end of the model year. If you report a negative balance of emission credits, we may disallow corrections under this paragraph (f)(~~2~~1).

(~~3~~2) If you or we determine any time that errors mistakenly increased your balance of emission credits, you must correct the errors and recalculate the balance of emission credits.

§ 1036.735 Recordkeeping.

(a) You must organize and maintain your records as described in this section. We may review your records at any time.

(b) Keep the records required by this section for at least eight years after the due date for the end-of-year report. You may not use emission credits for any engines if you do not keep all the records required under this section. You must therefore keep these records to continue to bank valid credits. Store these records in any format and on any media, as long as you can promptly send us organized, written records in English if we ask for them. You must keep these records readily available. We may review them at any time.

(c) Keep a copy of the reports we require in §§ 1036.725 and 1036.730.

(d) Keep records of the engine identification number (usually the serial number) for each engine you produce that generates or uses emission credits under the ABT program. You may identify these numbers as a range. If you change the FEL after the start of production, identify the date you started using each ~~FEL~~/FCL and the range of engine identification numbers associated with each ~~FEL~~/FCL. You must also identify the purchaser and destination for each engine you produce to the extent this information is available.

(e) We may require you to keep additional records or to send us relevant information not required by this section in accordance with the Clean Air Act.

§ 1036.740 Restrictions for using emission credits.

The following restrictions apply for using emission credits:

(a) *Averaging sets.* Except as specified in paragraph (c) of this section, emission credits may be exchanged only within the following averaging sets based on primary intended service class:

(1) ~~Engines subject to s~~Spark-ignition ~~standards~~HDE.

(2) Light ~~HDE~~heavy-duty engines.

(3) Medium ~~HDE~~heavy-duty engines.

(4) Heavy ~~HDE~~heavy-duty engines.

(b) *Applying credits to prior year deficits.* Where your CO₂ credit balance for the previous year is negative, you may apply credits to that ~~credit~~ deficit only after meeting your credit obligations for the current year.

(c) *CO₂ credits from hybrid engines and other advanced technologies.* CO₂ credits you generate under § 1036.615 may be used for any of the averaging sets identified in paragraph (a) of this section; you may also use those credits to demonstrate compliance with the CO₂ emission standards in 40 CFR 86.1819 and 40 CFR part 1037. Similarly, you may use Phase 1 advanced-technology credits generated under 40 CFR 86.1819-14(k)(7) or 40 CFR 1037.615 to demonstrate compliance with the CO₂ standards in this part. In the case of ~~S~~park-ignition HDE and ~~L~~ight ~~HDE~~ heavy-duty engines, you may not use more than 60,000 Mg of credits from other averaging sets in any model year.

(1)The maximum ~~amount of~~ CO₂ credits you may bring into the following service class groups is 60,000 Mg per model year:

- (i) ~~S~~park-ignition ~~HDE, light heavy-duty engines~~Light HDE, and ~~L~~ight ~~HDV~~heavy-duty vehicles. This group comprises the averaging sets listed in paragraphs (a)(1) and (2) of this section and the averaging set listed in 40 CFR 1037.740(a)(1).
- (ii) Medium ~~HDE heavy-duty engines~~ and ~~M~~medium ~~HDV~~heavy-duty vehicles. This group comprises the averaging sets listed in paragraph (a)(3) of this section and 40 CFR 1037.740(a)(2).
- (iii) Heavy ~~HDE heavy-duty engines~~ and ~~H~~heavy ~~HDV~~heavy-duty vehicles. This group comprises the averaging sets listed in paragraph (a)(4) of this section and 40 CFR 1037.740(a)(3).

(2) Paragraph (c)(1) of this section does not limit the advanced-technology credits that can be used within a service class group if they were generated in that same service class group.

(d) ~~NO_x and CO₂ c~~redit life. ~~NO_x and CO₂ c~~redits may be used only for five model years after the year in which they are generated. For example, credits you generate in model year ~~2027~~~~18~~ may be used to demonstrate compliance with emission standards only through model year ~~2023~~~~2~~.

(e) *Other restrictions.* Other sections of this part specify additional restrictions for using emission credits under certain special provisions.

§ 1036.741 Using emission credits from electric vehicles and hydrogen fuel-cell vehicles.

NO_x credits you generate under 40 CFR 1037.616 from electric vehicles may be used to demonstrate compliance with the NO_x emission standards in this part as follows:

(a) Credits may be averaged, banked, or traded as described in this subpart H.

(b) Averaging sets apply as specified in §1036.740 and 40 CFR 1037.102(b)(1).

(c) Banked credits may be used only for five model years as described in §1036.740(d).

§ 1036.745 End-of-year CO₂ credit deficits.

Except as allowed by this section, we may void the certificate of any engine family certified to an FCL above the applicable standard for which you do not have sufficient credits by the deadline for submitting the final report.

(a) Your certificate for an engine family for which you do not have sufficient CO₂ credits will not be void if you remedy the deficit with surplus credits within three model years. For example, if you have a credit deficit of 500 Mg for an engine family at the end of model year 2015, you must generate (or otherwise obtain) a surplus of at least 500 Mg in that same averaging set by the end of model year 2018.

(b) You may not bank or trade away CO₂ credits in the averaging set in any model year in which you have a deficit.

(c) You may apply only surplus credits to your deficit. You may not apply credits to a deficit from an earlier model year if they were generated in a model year for which any of your engine families for that averaging set had an end-of-year credit deficit.

(d) You must notify us in writing how you plan to eliminate the credit deficit within the specified time frame. If we determine that your plan is unreasonable or unrealistic, we may deny an application for certification for a vehicle family if its FEL would increase your credit deficit. We may determine that your plan is unreasonable or unrealistic based on a consideration of past and projected use of specific technologies, the historical sales mix of your vehicle models, your commitment to limit production of higher-emission vehicles, and expected access to traded credits. We may also consider your plan unreasonable if your credit deficit increases from one

model year to the next. We may require that you send us interim reports describing your progress toward resolving your credit deficit over the course of a model year.

(e) If you do not remedy the deficit with surplus credits within three model years, we may void your certificate for that engine family. We may void the certificate based on your end-of-year report. Note that voiding a certificate applies *ab initio*. Where the net deficit is less than the total amount of negative credits originally generated by the family, we will void the certificate only with respect to the number of engines needed to reach the amount of the net deficit. For example, if the original engine family generated 500 Mg of negative credits, and the manufacturer's net deficit after three years was 250 Mg, we would void the certificate with respect to half of the engines in the family.

(f) For purposes of calculating the statute of limitations, the following actions are all considered to occur at the expiration of the deadline for offsetting a deficit as specified in paragraph (a) of this section:

- (1) Failing to meet the requirements of paragraph (a) of this section.
- (2) Failing to satisfy the conditions upon which a certificate was issued relative to offsetting a deficit.
- (3) Selling, offering for sale, introducing or delivering into U.S. commerce, or importing vehicles that are found not to be covered by a certificate as a result of failing to offset a deficit.

§ 1036.750 ~~What can happen if I do not comply with the provisions of this subpart?~~ Consequences for noncompliance.

(a) For each engine family participating in the ABT program, the certificate of conformity is conditioned upon full compliance with the provisions of this subpart during and after the model year. You are responsible to establish to our satisfaction that you fully comply with applicable requirements. We may void the certificate of conformity for an engine family if you fail to comply with any provisions of this subpart.

(b) You may certify your engine family to an **FEL/FCL** above an applicable standard based on a projection that you will have enough emission credits to offset the deficit for the engine family. See § 1036.745 for provisions specifying what happens if you cannot show in your final report that you have enough actual emission credits to offset a deficit for any pollutant in an engine family.

(c) We may void the certificate of conformity for an engine family if you fail to keep records, send reports, or give us information we request. Note that failing to keep records, send reports, or give us information we request is also a violation of 42 U.S.C. 7522(a)(2).

(d) You may ask for a hearing if we void your certificate under this section (see § 1036.820).

§ 1036.755 Information provided to the Department of Transportation.

After receipt of each manufacturer's final report as specified in § 1036.730 and completion of any verification testing required to validate the manufacturer's submitted final data, we will issue a report to the Department of Transportation with CO₂ emission information and will verify the accuracy of each manufacturer's equivalent fuel consumption data that required by NHTSA under 49 CFR 535.8. We will send a report to DOT for each engine manufacturer based on each regulatory category and subcategory, including sufficient information for NHTSA to determine fuel consumption and associated credit values. See 49 CFR 535.8 to determine if NHTSA deems submission of this information to EPA to also be a submission to NHTSA.

Subpart I—Definitions and Other Reference Information

§ 1036.801 Definitions.

The following definitions apply to this part. The definitions apply to all subparts unless we note otherwise. All undefined terms have the meaning the Act gives to them. The definitions follow:

Act means the Clean Air Act, as amended, 42 U.S.C. 7401 - 7671q.

Adjustable parameter has the meaning given in 40 CFR [1068.50](#)~~part 86~~.

Advanced technology means technology certified under 40 CFR 86.1819-14(k)(7), § 1036.615, or 40 CFR 1037.615.

Aftertreatment means relating to a catalytic converter, particulate filter, or any other system, component, or technology mounted downstream of the exhaust valve (or exhaust port) whose design function is to decrease emissions in the engine exhaust before it is exhausted to the environment. Exhaust gas recirculation (EGR) and turbochargers are not aftertreatment.

Aircraft means any vehicle capable of sustained air travel more than 100 feet above the ground.

Alcohol-fueled engine mean an engine that is designed to run using an alcohol fuel. For purposes of this definition, alcohol fuels do not include fuels with a nominal alcohol content below 25 percent by volume.

Auxiliary emission control device means any element of design that senses temperature, motive speed, engine speed (r/min), transmission gear, or any other parameter for the purpose of activating, modulating, delaying, or deactivating the operation of any part of the emission control system.

Averaging set has the meaning given in § 1036.740.

Calibration means the set of specifications and tolerances specific to a particular design, version, or application of a component or assembly capable of functionally describing its operation over its working range.

Carryover means relating to certification based on emission data generated from an earlier model year as described in § 1036.235(d).

Certification means relating to the process of obtaining a certificate of conformity for an engine family that complies with the emission standards and requirements in this part.

Certified emission level means the highest deteriorated emission level in an engine family for a given pollutant from the applicable transient and/or steady-state testing, rounded to the same number of decimal places as the applicable standard. Note that you may have two certified emission levels for CO₂ if you certify a family for both vocational and tractor use.

Charge-depleting has the meaning given in 40 CFR 1066.1001.

[Charge-sustaining has the meaning given in 40 CFR 1066.1001.](#)

Complete vehicle means a vehicle meeting the definition of complete vehicle in 40 CFR 1037.801 when it is first sold as a vehicle. For example, where a vehicle manufacturer sells an incomplete vehicle to a secondary vehicle manufacturer, the vehicle is not a complete vehicle under this part, even after its final assembly.

Compression-ignition means relating to a type of reciprocating, internal-combustion engine that is not a spark-ignition engine. Note that § 1036.1 also deems gas turbine engines and other engines to be compression-ignition engines.

Crankcase emissions means airborne substances emitted to the atmosphere from any part of the engine crankcase's ventilation or lubrication systems. The crankcase is the housing for the crankshaft and other related internal parts.

Criteria pollutants means emissions of NO_x, HC, PM, and CO.

[Critical emission-related component has the meaning given in 40 CFR 1068.30.](#)

[Defeat device has the meaning given in §1036.115\(h\).](#)

Designated Compliance Officer means one of the following:

- (1) For engines subject to compression-ignition standards, *Designated Compliance Officer* means Director, Diesel Engine Compliance Center, U.S. Environmental Protection Agency, 2000 Traverwood Drive, Ann Arbor, MI 48105; complianceinfo@epa.gov; www.epa.gov/ve-certificationotaq/verify.
- (2) For engines subject to spark-ignition standards, *Designated Compliance Officer* means Director, Gasoline Engine Compliance Center, U.S. Environmental Protection Agency, 2000 Traverwood Drive, Ann Arbor, MI 48105; nonroad-si-cert@epa.gov; www.epa.gov/ve-certificationotaq/verify.

Deteriorated emission level means the emission level that results from applying the appropriate deterioration factor to the official emission result of the emission-data engine. Note that where no deterioration factor applies, references in this part to the *deteriorated emission level* mean the official emission result.

Deterioration factor means the relationship between emissions at the end of useful life (or point of highest emissions if it occurs before the end of useful life) and emissions at the low-hour/low-mileage ~~test~~ point, expressed in one of the following ways:

- (1) For multiplicative deterioration factors, the ratio of emissions at the end of useful life (or point of highest emissions) to emissions at the low-hour ~~test~~ point.
- (2) For additive deterioration factors, the difference between emissions at the end of useful life (or point of highest emissions) and emissions at the low-hour ~~test~~ point.

Diesel exhaust fluid (DEF) means a liquid reducing agent (other than the engine fuel) used in conjunction with selective catalytic reduction to reduce NO_x emissions. *Diesel exhaust fluid* is generally understood to be an aqueous solution of urea conforming to the specifications of ISO 22241.

Dual-fuel means relating to an engine designed for operation on two different types of fuel but not on a continuous mixture of those fuels (see § 1036.601(d)). For purposes of this part, such an engine remains a dual-fuel engine even if it is designed for operation on three or more different fuels.

Electronic control module (ECM) means an engine's electronic device that uses data from engine sensors to control engine parameters.

Emission control system means any device, system, or element of design that controls or reduces the emissions of regulated pollutants from an engine.

Emission-data engine means an engine that is tested for certification. This includes engines tested to establish deterioration factors.

Emission-related component has the meaning given in 40 CFR part 1068, appendix A.

Emission-related maintenance means maintenance that substantially affects emissions or is likely to substantially affect emission deterioration.

Engine configuration means a unique combination of engine hardware and calibration (related to the emission standards) within an engine family, which would include hybrid components for engines certified as hybrid engines and hybrid powertrains. Engines within a single engine configuration differ only with respect to normal production variability or factors unrelated to compliance with emission standards.

Engine family has the meaning given in § 1036.230.

Excluded means relating to engines that are not subject to some or all of the requirements of this part as follows:

- (1) An engine that has been determined not to be a heavy-duty engine is excluded from this part.
- (2) Certain heavy-duty engines are excluded from the requirements of this part under § 1036.5.
- (3) Specific regulatory provisions of this part may exclude a heavy-duty engine generally subject to this part from one or more specific standards or requirements of this part.

Exempted has the meaning given in 40 CFR 1068.30.

Exhaust gas recirculation means a technology that reduces emissions by routing exhaust gases that had been exhausted from the combustion chamber(s) back into the engine to be mixed with incoming air before or during combustion. The use of valve timing to increase the amount of residual exhaust gas in the combustion chamber(s) that is mixed with incoming air before or during combustion is not considered exhaust gas recirculation for the purposes of this part.

Family certification level (FCL) means a CO₂ emission level declared by the manufacturer that is at or above emission ~~test~~ results for all emission-data engines. The FCL serves as the emission standard for the engine family with respect to certification testing if it is different than the otherwise applicable standard. ~~The FCL must be expressed to the same number of decimal~~

~~places as the emission standard it replaces.~~

Family emission limit (FEL) means one of the following:

(1) For NO_x emissions, family emission limit (FEL) means a NO_x an-emission level declared by the manufacturer to serve in place of an otherwise applicable emission standard ~~(other than CO₂ standards)~~ under the ABT program in subpart H of this part. ~~The FEL must be expressed to the same number of decimal places as the emission standard it replaces.~~ The FEL serves as the emission standard for the engine family with respect to all required testing ~~except certification testing for CO₂.~~

(2) For greenhouse gas standards, family emission limit (FEL) is the standard that applies for testing individual engines. The CO₂ FEL is equal to the CO₂ FCL multiplied by 1.03 and rounded to the same number of decimal places as the standard ~~(e.g., the nearest whole g/hp-hr for the 2016 CO₂ standards).~~

Federal Test Procedure (FTP) means the applicable transient duty cycle described in § 1036.510 designed to measure exhaust emissions during urban driving.

Flexible-fuel means relating to an engine designed for operation on any mixture of two or more different types of fuels (see § 1036.601(d)).

Fuel type means a general category of fuels such as diesel fuel, gasoline, or natural gas. There can be multiple grades within a single fuel type, such as premium gasoline, regular gasoline, or gasoline with 10 percent ethanol.

Good engineering judgment has the meaning given in 40 CFR 1068.30. See 40 CFR 1068.5 for the administrative process we use to evaluate good engineering judgment.

Greenhouse gas means one or more compounds regulated under this part based primarily on their impact on the climate. This generally includes CO₂, CH₄, and N₂O.

Greenhouse gas Emissions Model (GEM) means the GEM simulation tool described in 40 CFR 1037.520. Note that an updated version of GEM applies starting in model year 2021.

Gross vehicle weight rating (GVWR) means the value specified by the vehicle manufacturer as the maximum design loaded weight of a single vehicle, consistent with good engineering judgment.

Heavy-duty engine means any engine which the engine manufacturer could reasonably expect to be used for motive power in a heavy-duty vehicle. For purposes of this definition in this part, the term “engine” includes internal combustion engines and other devices that convert chemical fuel into motive power. For example, a fuel cell or a gas turbine used in a heavy-duty vehicle is a heavy-duty engine.

Heavy-duty vehicle means any motor vehicle above 8,500 pounds GVWR. An incomplete vehicle is also a heavy-duty vehicle if it has a curb weight above 6,000 pounds or a basic vehicle frontal area greater than 45 square feet. *Curb weight* and *basic vehicle frontal area* have the

meaning given in 40 CFR 86.1803-01.

Hybrid means an engine or powertrain that includes energy storage features other than a conventional battery system or conventional flywheel. Supplemental electrical batteries and hydraulic accumulators are examples of hybrid energy storage systems. Note that certain provisions in this part treat hybrid engines and hybrid powertrains intended for vehicles that include regenerative braking different than those intended for vehicles that do not include regenerative braking.

Hybrid engine means a hybrid system with features for storing and recovering energy that are integral to the engine or are otherwise upstream of the vehicle's transmission other than a conventional battery system or conventional flywheel. Supplemental electrical batteries and hydraulic accumulators are examples of hybrid energy storage systems. Examples of hybrids that could be considered hybrid engines are P0, P1, and P2 hybrids where hybrid features are connected to the front end of the engine, at the crankshaft, or connected between the clutch and the transmission where the clutch upstream of the hybrid feature is in addition to the transmission clutch(s), respectively. Note other examples of systems that qualify as hybrid engines are systems that recover kinetic energy and use it to power an electric heater in the aftertreatment.

Hybrid powertrain means a powertrain that includes energy storage features other than a conventional battery system or conventional flywheel. Supplemental electrical batteries and hydraulic accumulators are examples of hybrid energy storage systems. Note other examples of systems that qualify as hybrid powertrains are systems that recover kinetic energy and use it to power an electric heater in the aftertreatment.

Hydrocarbon (HC) ~~has the meaning given in 40 CFR 1065.1001 means the hydrocarbon group on which the emission standards are based for each fuel type. For alcohol fueled engines, HC means nonmethane hydrocarbon equivalent (NMHCE). For all other engines, HC means nonmethane hydrocarbon (NMHC).~~

Identification number means a unique specification (for example, a model number/serial number combination) that allows someone to distinguish a particular engine from other similar engines.

Incomplete vehicle means a vehicle meeting the definition of incomplete vehicle in 40 CFR 1037.801 when it is first sold (or otherwise delivered to another entity) as a vehicle.

Innovative technology means technology certified under § 1036.610 (also described as “off-cycle technology”).

Liquefied petroleum gas (LPG) means a liquid hydrocarbon fuel that is stored under pressure and is composed primarily of nonmethane compounds that are gases at atmospheric conditions. Note that, although this commercial term includes the word “petroleum”, LPG is not considered to be a petroleum fuel under the definitions of this section.

Low-hour means relating to an engine that has stabilized emissions and represents the undeteriorated emission level. This would generally involve less than 300 ~~125~~ hours of operation for engines with NO_x aftertreatment and 125 hours of operation for other engines.

Manufacture means the physical and engineering process of designing, constructing, and/or assembling a heavy-duty engine or a heavy-duty vehicle.

Manufacturer has the meaning given in [40 CFR 1068.30](#). ~~section 216(1) of the Act. In general, this term includes any person who manufactures or assembles an engine, vehicle, or piece of equipment for sale in the United States or otherwise introduces a new engine into commerce in the United States. This includes importers who import engines or vehicles for resale.~~

Medium-duty passenger vehicle has the meaning given in 40 CFR 86.1803.

Mild hybrid means a hybrid engine or powertrain with regenerative braking capability where the system recovers less than 20 percent of the total braking energy over the transient cycle defined in [Appendix A](#) of 40 CFR part 1037.

Model year means the manufacturer's annual new model production period, except as restricted under this definition. It must include January 1 of the calendar year for which the model year is named, may not begin before January 2 of the previous calendar year, and it must end by December 31 of the named calendar year. Manufacturers may not adjust model years to circumvent or delay compliance with emission standards or to avoid the obligation to certify annually.

Motor vehicle has the meaning given in 40 CFR 85.1703.

Natural gas means a fuel whose primary constituent is methane.

New motor vehicle engine has the meaning given in the Act. This generally means a motor vehicle engine meeting the criteria of either paragraph (1), (2), or (3) of this definition.

- (1) A motor vehicle engine for which the ultimate purchaser has never received the equitable or legal title is a *new motor vehicle engine*. This kind of engine might commonly be thought of as "brand new" although a *new motor vehicle engine* may include previously used parts. Under this definition, the engine is new from the time it is produced until the ultimate purchaser receives the title or places it into service, whichever comes first.
- (2) An imported motor vehicle engine is a *new motor vehicle engine* if it was originally built on or after January 1, 1970.
- (3) Any motor vehicle engine installed in a new motor vehicle.

Noncompliant engine means an engine that was originally covered by a certificate of conformity, but is not in the certified configuration or otherwise does not comply with the conditions of the certificate.

Nonconforming engine means an engine not covered by a certificate of conformity that would otherwise be subject to emission standards.

Nonmethane hydrocarbon (NMHC) means the sum of all hydrocarbon species except methane, as measured according to 40 CFR part 1065.

Nonmethane hydrocarbon equivalent (NMHCE) has the meaning given in 40 CFR 1065.1001.

Nonmethane nonethane hydrocarbon equivalent (NMNEHC) has the meaning given in 40 CFR 1065.1001.

Off-cycle technology means technology certified under § 1036.610 (also described as “innovative technology”).

Official emission result means the measured emission rate for an emission-data engine on a given duty cycle before the application of any deterioration factor, but after the applicability of any required regeneration or other adjustment factors.

Owners manual means a document or collection of documents prepared by the engine or vehicle manufacturer for the owner or operator to describe appropriate engine maintenance, applicable warranties, and any other information related to operating or keeping the engine. The owners manual is typically provided to the ultimate purchaser at the time of sale. The owners manual may be in paper or electronic format.

Oxides of nitrogen has the meaning given in 40 CFR 1065.1001.

Percent has the meaning given in 40 CFR 1065.1001. Note that this means percentages identified in this part are assumed to be infinitely precise without regard to the number of significant figures. For example, one percent of 1,493 is 14.93.

Placed into service means put into initial use for its intended purpose, excluding incidental use by the manufacturer or a dealer.

Preliminary approval means approval granted by an authorized EPA representative prior to submission of an application for certification, consistent with the provisions of § 1036.210.

Primary intended service class has the meaning given in § 1036.140.

OR Code means Quick Response Code, which is a registered trademark of Denso Wave, Incorporated.

~~*Rechargeable Energy Storage System (RESS)* has the meaning given in 40 CFR 1065.1001 means the component(s) of a hybrid engine or vehicle that store recovered energy for later use, such as the battery system in an electric hybrid vehicle.~~

Relating to as used in this section means relating to something in a specific, direct manner. This expression is used in this section only to define terms as adjectives and not to broaden the meaning of the terms.

Revoke has the meaning given in 40 CFR 1068.30.

Round has the meaning given in 40 CFR 1065.1001.

~~*Test Sample* means the collection of engines selected from the population of an engine family for emission testing. This may include testing for certification, production-line testing, or in-use testing.~~

Scheduled maintenance means adjusting, ~~repairing~~, removing, disassembling, cleaning, or replacing components or systems periodically to keep a part or system from failing, malfunctioning, or wearing prematurely. ~~It also may mean actions you expect are necessary to correct an overt indication of failure or malfunction for which periodic maintenance is not appropriate.~~

Small manufacturer means a manufacturer meeting the criteria specified in 13 CFR 121.201. The employee and revenue limits apply to the total number of employees and total revenue together for affiliated companies. Note that manufacturers with low production volumes may or may not be “small manufacturers”.

Spark-ignition means relating to a gasoline-fueled engine or any other type of engine with a spark plug (or other sparking device) and with operating characteristics significantly similar to the theoretical Otto combustion cycle. Spark-ignition engines usually use a throttle to regulate intake air flow to control power during normal operation.

Steady-state has the meaning given in 40 CFR 1065.1001. This includes fuel mapping and idle testing where engine speed and load are held at a finite set of nominally constant values.

Suspend has the meaning given in 40 CFR 1068.30.

Test engine means an engine in a ~~test~~-sample.

Tractor means a vehicle meeting the definition of “tractor” in 40 CFR 1037.801, but not classified as a “vocational tractor” under 40 CFR 1037.630, or relating to such a vehicle.

Tractor engine means an engine certified for use in tractors. Where an engine family is certified for use in both tractors and vocational vehicles, “tractor engine” means an engine that the engine manufacturer reasonably believes will be (or has been) installed in a tractor. Note that the provisions of this part may require a manufacturer to document how it determines that an engine is a tractor engine.

Ultimate purchaser means, with respect to any new engine or vehicle, the first person who in good faith purchases such new engine or vehicle for purposes other than resale.

United States has the meaning given in 40 CFR 1068.30.

Upcoming model year means for an engine family the model year after the one currently in production.

U.S.-directed production volume means the number of engines, subject to the requirements of this part, produced by a manufacturer for which the manufacturer has a reasonable assurance that sale was or will be made to ultimate purchasers in the United States. This does not include engines certified to state emission standards that are different than the emission standards in this part.

Vehicle has the meaning given in 40 CFR 1037.801.

Vocational engine means an engine certified for use in vocational vehicles. Where an engine family is certified for use in both tractors and vocational vehicles, “vocational engine” means an engine that the engine manufacturer reasonably believes will be (or has been) installed in a vocational vehicle. Note that the provisions of this part may require a manufacturer to document how it determines that an engine is a vocational engine.

Vocational vehicle means a vehicle meeting the definition of “vocational” vehicle in 40 CFR 1037.801.

Void has the meaning given in 40 CFR 1068.30.

We (us, our) means the Administrator of the Environmental Protection Agency and any authorized representatives.

§ 1036.805 Symbols, abbreviations, and acronyms.

The procedures in this part generally follow either the International System of Units (SI) or the United States customary units, as detailed in NIST Special Publication 811 (incorporated by reference in § 1036.810). See 40 CFR 1065.20 for specific provisions related to these conventions. This section summarizes the way we use symbols, units of measure, and other abbreviations.

(a) *Symbols for chemical species.* This part uses the following symbols for chemical species and exhaust constituents:

[Table 1 of §1036.805—Symbols for Chemical Species and Exhaust Constituents](#)

Symbol	Species
C	carbon.
CH ₄	methane.
CH ₄ N ₂ O	urea.
CO	carbon monoxide.
CO ₂	carbon dioxide.
H ₂ O	water.
HC	hydrocarbon.
NMHC	nonmethane hydrocarbon.
NMHCE	nonmethane hydrocarbon equivalent.
NMNEHC	nonmethane nonethane hydrocarbon.
NO	nitric oxide.
NO ₂	nitrogen dioxide.
NO _x	oxides of nitrogen.
N ₂ O	nitrous oxide.
PM	particulate matter.

(b) *Symbols for quantities.* This part uses the following symbols and units of measure for various quantities:

Table 2 ~~of~~ §1036.805—Symbols for Quantities

Symbol	Quantity	Unit	Unit Symbol	Unit in Terms of SI Base Units
	atomic hydrogen-to-carbon ratio	mole per mole	mol/mol	1
	Area	square meter	m ²	m ²
	atomic oxygen-to-carbon ratio	mole per mole	mol/mol	1
C_dA	drag area	meter squared	m ²	m ²
C_{rr}	coefficient of rolling resistance	kilogram per metric ton newton per kilonewton	N/kg/tonne	10 ⁻³
D	distance	miles or meters	mi or m	m
ε	efficiency			
ϵ	Difference or error quantity			
e	mass weighted emission result	grams/ton-mile	g/ton-mi	g/kg-km
Eff	efficiency			
E_m	mass-specific net energy content	megajoules/kilogram	MJ/kg	m ² ·s ⁻²
f_n	angular speed (shaft)	revolutions per minute	r/min	$\pi \cdot 30 \cdot s^{-1}$
g	gravitational acceleration	meters per second squared	m/s ²	m·s ⁻²
i	indexing variable			
k_a	drive axle ratio			1
$k_{topgear}$	highest available transmission gear			
m	Mass	pound mass or kilogram	lbm or kg	kg
M	molar mass	gram per mole	g/mol	10 ⁻³ ·kg·mol ⁻¹
\underline{M}	<u>total number in a series</u>			
M	vehicle mass	kilogram	kg	kg
$M_{rotating}$	inertial mass of rotating components	kilogram	kg	kg
N	total number in a series			
\underline{Q}	<u>total number in a series</u>			
P	Power	kilowatt	kW	10 ³ ·m ² ·kg·s ⁻³
ρ	mass density	kilogram per cubic meter	kg/m ³	m ⁻³ ·kg
r	tire radius	meter	m	m
SEE	standard error of the estimate			
σ	standard deviation			

T	torque (moment of force)	newton meter	N·m	$m^2 \cdot kg \cdot s^{-2}$
t	Time	second	s	s
Δt	time interval, period, 1/frequency	second	s	s
UF	utility factor			
v	Speed	miles per hour or meters per second	mi/hr or m/s	$m \cdot s^{-1}$
W	Work	kilowatt-hour	kW·hr	$3.6 \cdot m^2 \cdot kg \cdot s^{-1}$
w_C	carbon mass fraction	gram/gram	g/g	1
$w_{CH_4N_2O}$	urea mass fraction	gram/gram	g/g	1
x	amount of substance mole fraction	mole per mole	mol/mol	1
x_b	brake energy fraction			
x_{bl}	brake energy limit			

(c) *Superscripts*. This part uses the following superscripts for modifying quantity symbols:

Table 3 of §1036.805—Superscripts

Superscript	Meaning
overbar (such as \bar{y})	arithmetic mean
overdot (such as \dot{y})	quantity per unit time.

(d) *Subscripts*. This part uses the following subscripts for modifying quantity symbols:

Table 4 of §1036.805—Subscripts

Subscript	Meaning
65	65 miles per hour.
A	A speed.
aA	absolute (e.g., absolute difference or error).
$aAcc$	accessory.
$aApp$	approved.
$aAxle$	axle.
B	B speed.
C	C speed.
C	carbon mass.
$C_{combdry}$	carbon from fuel per mole of dry exhaust.
CD	charge-depleting.
CO_2DEF	CO_2 resulting from diesel exhaust fluid decomposition.
comb	combustion.
comp	composite.
$cCor$	corrected.

CS	charge-sustaining.
<u>c</u> Cycle	<u>test</u> cycle.
<u>D</u>	<u>distance</u> .
<u>D</u>	<u>D speed</u> .
DEF	diesel exhaust fluid.
engine	engine.
<u>e</u> Exh	raw exhaust.
<u>f</u> Front	frontal.
<u>f</u> Fuel	fuel.
H ₂ O exhaust dry	H ₂ O in exhaust per mole of exhaust.
<u>h</u> Hi	high.
<u>i</u> I	an individual of a series.
<u>i</u> Idle	idle.
<u>int</u>	<u>test interval</u> .
<u>j</u>	<u>an individual of a series</u> .
<u>k</u>	<u>an individual of a series</u> .
<u>m</u> M	mass.
<u>m</u> Max	maximum.
mapped	mapped.
<u>m</u> Meas	measured quantity.
<u>MY</u>	<u>model year</u> .
<u>n</u> Neg	negative.
<u>p</u> Pos	positive.
<u>R</u>	<u>range</u> .
<u>r</u> R	relative (e.g., relative difference or error).
<u>r</u> Rate	rate (divided by time).
<u>r</u> Rated	rated.
record	record.
<u>r</u> Ref	reference quantity.
speed	speed.
<u>s</u> Stall	stall.
<u>t</u> Test	test.
<u>t</u> Tire	tire.
transient	transient.
<u>μ</u> M	vector.
<u>UF</u>	<u>utility factor</u> .
vehicle	vehicle.

(e) *Other acronyms and abbreviations.* This part uses the following additional abbreviations and acronyms:

Table 5 of to §1036.805—Other Acronyms and Abbreviations

Acronym	Meaning
ABT	averaging, banking, and trading.
AECD	auxiliary emission control device.

ASTM	American Society for Testing and Materials.
BTU	British thermal units.
CD	charge-depleting.
CFR	Code of Federal Regulations.
CI	compression-ignition.
COV	coefficient of variation.
CS	charge-sustaining.
DEF	diesel exhaust fluid.
DF	deterioration factor.
DOT	Department of Transportation.
E85	gasoline blend including nominally 85 percent denatured ethanol.
ECMU	Electronic Control Unit Module.
<u>EGR</u>	<u>exhaust gas recirculation.</u>
EPA	Environmental Protection Agency.
FCL	Family Certification Level.
FEL	Family Emission Limit.
<u>FTP</u>	<u>Federal Test Procedure.</u>
GEM	Greenhouse gas Emissions Model.
g/hp _{-hr}	grams per brake horsepower-hour.
<u>GPS</u>	<u>global positioning system.</u>
GVWR	gross vehicle weight rating.
<u>Heavy HDE</u>	<u>heavy heavy-duty engine (see § 1036.140).</u>
<u>Heavy HDV</u>	<u>heavy heavy-duty vehicle (see 40 CFR 1037.140).</u>
<u>Light HDE</u>	<u>light heavy-duty engine (see § 1036.140).</u>
<u>Light HDV</u>	<u>light heavy-duty vehicle (see 40 CFR 1037.140).</u>
<u>LLC</u>	<u>Low Load Cycle.</u>
LPG	liquefied petroleum gas.
<u>Medium HDE</u>	<u>medium heavy-duty engine (see § 1036.140).</u>
<u>Medium HDV</u>	<u>medium heavy-duty vehicle (see 40 CFR 1037.140).</u>
NARA	National Archives and Records Administration.
NHTSA	National Highway Traffic Safety Administration.
NTE	not-to-exceed.
<u>PEMS</u>	<u>portable emission measurement system.</u>
RESS	rechargeable energy storage system.
<u>RMC</u>	<u>ramped-modal cycle</u>
SCR	selective catalytic reduction.
SEE	standard error of the estimate.
SET	Supplemental Emission Test.
<u>Spark-ignition HDE</u>	<u>spark-ignition heavy-duty engine (see § 1036.140).</u>
SI	<u>s</u> Spark-ignition.
<u>UL</u>	<u>useful life.</u>
U.S.	United States.
U.S.C.	United States Code.

(f) *Constants.* This part uses the following constants:

Table 6 of ~~the~~ §1036.805—Constants

Symbol	Quantity	Value
<i>g</i>	gravitational constant	9.80665 m·s ⁻²

(g) *Prefixes*. This part uses the following prefixes to define a quantity:

Table 7 of ~~the~~ §1036.805—Prefixes

Symbol	Quantity	Value
μ	micro	10 ⁻⁶
m	milli	10 ⁻³
c	centi	10 ⁻²
k	kilo	10 ³
M	mega	10 ⁶

§ 1036.810 Incorporation by reference.

Certain material is incorporated by reference into this part with the approval of the Director of the Federal Register under 5 U.S.C. 552(a) and 1 CFR part 51. To enforce any edition other than that specified in this section, the Environmental Protection Agency must publish a document in the *Federal Register* and the material must be available to the public. All approved material is available for inspection at U.S. EPA, Air and Radiation Docket and Information Center, WJC West Building, Room 3334, 1301 Constitution Ave., NW., Washington, DC 20460, www.epa.gov/dockets, (202) 202-1744, and is available from the sources listed in this section. It is also available for inspection at the National Archives and Records Administration (NARA). For information on the availability of this material at NARA, [email fr.inspection@nara.gov](mailto:email.fr.inspection@nara.gov) call [202-741-6030](tel:202-741-6030), or go to www.archives.gov/federal-register/cfr/ibr-locations.html.

(a) ASTM International, 100 Barr Harbor Drive, P.O. Box C700, West Conshohocken, PA, 19428-2959, (877) 909-2786, [or www.astm.org](http://www.astm.org).

(1) [ASTM D975-20c, Standard Specification for Diesel Fuel Oils, approved November 1, 2020 \(“ASTM D975”\), IBR approved for §1036.410\(c\).](#)

(2) [ASTM D3588-98 \(Reapproved 2017\)e1, Standard Practice for Calculating Heat Value, Compressibility Factor, and Relative Density of Gaseous Fuels, approved April 1, 2017; \(“ASTM D3588”\), IBR approved for § 1036.530\(b\).](#)

(3) [ASTM D4809-13, Standard ~~Test~~ Method for Heat of Combustion of Liquid Hydrocarbon Fuels by Bomb Calorimeter \(Precision Method\), approved May 1, 2013; \(“ASTM D4809”\), IBR approved for § 1036.530\(b\).](#)

(4) [ASTM D4814-21a, Standard Specification for Automotive Spark-Ignition Engine Fuel, approved April 1, 2021 \(“ASTM D4814”\), IBR approved for § 1036.415\(c\).](#)

(5) [ASTM D7467-20a, Standard Specification for Diesel Fuel Oil, Biodiesel Blend \(B6 to B20\), approved June 1, 2020 \(“ASTM D7467”\), IBR approved for § 1036.415\(c\).](#)

(b) National Institute of Standards and Technology, 100 Bureau Drive, Stop 1070, Gaithersburg, MD 20899-1070, (301) 975-6478, or www.nist.gov.

(1) NIST Special Publication 811, Guide for the Use of the International System of Units (SI), 2008 Edition, March 2008, IBR approved for § 1036.805.

(2) [Reserved]

(c) International Organization for Standardization, Case Postale 56, CH-1211 Geneva 20, Switzerland, (41) 22749 0111, www.iso.org, or central@iso.org.

(1) ISO/IEC 18004:2015(E), Information technology—Automatic identification and data capture techniques—QR Code bar code symbology specification, Third Edition, February 2015, IBR approved for §1036.135(c).

(2) [Reserved]

(d) California Air Resources Board, 1001 I Street, Sacramento, CA 95812, (916) 322-2884, or www.arb.ca.gov:

(1) California's 2019 heavy-duty OBD requirements adopted under 13 CCR 1968.2, 1968.5, 1971.1, and 1971.5, IBR approved for §1036.110.

(2) [Reserved]

(e) SAE International, 400 Commonwealth Dr., Warrendale, PA 15096-0001, (877) 606-7323 (U.S. and Canada) or (724) 776-4970 (outside the U.S. and Canada), or www.sae.org:

(1) SAE J1979-2, E/E Diagnostic Test Modes: OBDonUDS, April 22, 2021, IBR approved for §1036.150(u).

(2) [Reserved]

§ 1036.815 Confidential information.

(a) The provisions of 40 CFR 1068.10 [and 1068.11](#) apply for submitted information you [submit under this part](#)~~consider confidential~~.

(b) [Emission data or information that is publicly available cannot be treated as confidential business information as described in 40 CFR 1068.11. Data that vehicle manufacturers need for demonstrating compliance with greenhouse gas emission standards, including fuel-consumption data as described in §1036.535 and 40 CFR 1037.550, also qualify as emission data for purposes of confidentiality determinations.](#)

§ 1036.820 Requesting a hearing.

(a) You may request a hearing under certain circumstances, as described elsewhere in this part. To do this, you must file a written request, including a description of your objection and any supporting data, within 30 days after we make a decision.

(b) For a hearing you request under the provisions of this part, we will approve your request if we find that your request raises a substantial factual issue.

(c) If we agree to hold a hearing, we will use the procedures specified in 40 CFR part 1068, subpart G.

§ 1036.825 Reporting and recordkeeping requirements.

(a) This part includes various requirements to submit and record data or other information. Unless we specify otherwise, store required records in any format and on any media and keep them readily available for eight years after you send an associated application for certification, or eight years after you generate the data if they do not support an application for certification. We may review these records at any time. You must promptly give us organized, written records in English if we ask for them. We may require you to submit written records in an electronic format.

(b) The regulations in § 1036.255 and 40 CFR 1068.25 and 1068.101 describe your obligation to report truthful and complete information. This includes information not related to certification. Failing to properly report information and keep the records we specify violates 40 CFR 1068.101(a)(2), which may involve civil or criminal penalties.

(c) Send all reports and requests for approval to the Designated Compliance Officer (see § 1036.801).

(d) Any written information we require you to send to or receive from another company is deemed to be a required record under this section. Such records are also deemed to be submissions to EPA. Keep these records for eight years unless the regulations specify a different period. We may require you to send us these records whether or not you are a certificate holder.

(e) Under the Paperwork Reduction Act (44 U.S.C. 3501 et seq.), the Office of Management and Budget approves the reporting and recordkeeping specified in the applicable regulations. The following items illustrate the kind of reporting and recordkeeping we require for engines and vehicles regulated under this part:

(1) We specify the following requirements related to engine certification in this part ~~1036~~:

(i) In § 1036.135 we require engine manufacturers to keep certain records related to duplicate labels sent to vehicle manufacturers.

(ii) In § 1036.150 we include various reporting and recordkeeping requirements related to interim provisions.

(iii) In subpart C of this part we identify a wide range of information required to certify engines.

(iv) In §§ 1036.430 and 1036.435 we identify reporting and recordkeeping requirements related to field testing in-use engines.

~~(iv)~~ In subpart G of this part we identify several reporting and recordkeeping items for making demonstrations and getting approval related to various special compliance provisions.

~~(v)~~ In §§ 1036.725, 1036.730, and 1036.735 we specify certain records related to averaging, banking, and trading.

(2) We specify the following requirements related to testing in 40 CFR part 1065:

(i) In 40 CFR 1065.2 we give an overview of principles for reporting information.

(ii) In 40 CFR 1065.10 and 1065.12 we specify information needs for establishing various changes to published ~~test~~ procedures.

(iii) In 40 CFR 1065.25 we establish basic guidelines for storing ~~test~~ information.

(iv) In 40 CFR 1065.695 we identify the specific information and data items to record when measuring emissions.

(3) We specify the following requirements related to the general compliance provisions in 40 CFR part 1068:

(i) In 40 CFR 1068.5 we establish a process for evaluating good engineering judgment related to testing and certification.

(ii) In 40 CFR 1068.25 we describe general provisions related to sending and keeping information

(iii) In 40 CFR 1068.27 we require manufacturers to make engines available for our testing or inspection if we make such a request.

(iv) In 40 CFR 1068.105 we require vehicle manufacturers to keep certain records related to duplicate labels from engine manufacturers.

(v) In 40 CFR 1068.120 we specify recordkeeping related to rebuilding engines.

(vi) In 40 CFR part 1068, subpart C, we identify several reporting and recordkeeping items for making demonstrations and getting approval related to various exemptions.

(vii) In 40 CFR part 1068, subpart D, we identify several reporting and recordkeeping items for making demonstrations and getting approval related to importing engines.

- (viii) In 40 CFR 1068.450 and 1068.455 we specify certain records related to testing production-line engines in a selective enforcement audit.
- (ix) In 40 CFR 1068.501 we specify certain records related to investigating and reporting emission-related defects.
- (x) In 40 CFR 1068.525 and 1068.530 we specify certain records related to recalling nonconforming engines.
- (xi) In 40 CFR part 1068, subpart G, we specify certain records for requesting a hearing.

Appendix A ~~to~~ of Part 1036—Summary of Previous Emission Standards

The following standards, which EPA originally adopted under 40 CFR part 85 or part 86, apply to compression-ignition engines produced before model year 2007 and to spark-ignition engines produced before model year 2008:

- (a) *Smoke*. Smoke standards applied for compression-ignition engines based on opacity measurement using the test procedures in 40 CFR part 86, subpart I, as follows:
- (1) Engines were subject to the following smoke standards for model years 1970 through 1973:
 - (i) 40 percent during the engine acceleration mode.
 - (ii) 20 percent during the engine lugging mode.
 - (2) The smoke standards in 40 CFR 86.007-11 started to apply in model year 1974.
- (b) *Idle CO*. A standard of 0.5 percent of exhaust gas flow at curb idle applied through model year 2016 to the following engines:
- (1) Spark-ignition engines with aftertreatment starting in model year 1987. This standard applied only for gasoline-fueled engines through model year 1997. Starting in model year 1998, the same standard applied for engines fueled by methanol, LPG, and natural gas. The idle CO standard no longer applied for engines certified to meet onboard diagnostic requirements starting in model year 2005.
 - (2) Methanol-fueled compression-ignition engines starting in model year 1990. This standard also applied for natural gas and LPG engines starting in model year 1997. The idle CO standard no longer applied for engines certified to meet onboard diagnostic requirements starting in model year 2007.
- (c) *Crankcase emissions*. The requirement to design engines to prevent crankcase emissions applied starting with the following engines:
- (1) Spark-ignition engines starting in model year 1968. This standard applied only for gasoline-fueled engines through model year 1989, and applied for spark-ignition engines using other fuels starting in model year 1990.
 - (2) Naturally aspirated diesel-fueled engines starting in model year 1985.
 - (3) Methanol-fueled compression-ignition engines starting in model year 1990.
 - (4) Naturally aspirated gaseous-fueled engines starting in model year 1997, and all other gaseous-fueled engines starting in 1998.
- (d) *Early steady-state standards*. The following criteria standards applied to heavy-duty engines based on steady-state measurement procedures:

Table 1 ~~to~~ of Appendix A—Early Steady-State Emission Standards for Heavy-Duty Engines

Model Year	Fuel	Pollutant		
		HC	NO _x + HC	CO
1970-1973	gasoline	275 ppm	—	1.5 volume percent
1974-1978	gasoline and diesel	—	16 g/hp·hr	40 g/hp·hr
1979-1984 ^a	gasoline and diesel	—	5 g/hp·hr for diesel 5.0 g/hp·hr for gasoline	25 g/hp·hr

^aAn optional NO_x + HC standard of 10 g/hp·hr applied in 1979 through 1984 in conjunction with a separate HC standard of 1.5 g/hp·hr.

- (e) *Transient emission standards for spark-ignition engines*. The following criteria standards applied for spark-ignition engines based on transient measurement using the test procedures in

40 CFR part 86, subpart N. Starting in model year 1991, manufacturers could generate or use emission credits for NO_x and NO_x + NMHC standards. Table 2 to this appendix follows:

Table 2 ~~to~~ of Appendix A—Transient Emission Standards for Spark-Ignition Engines^{a,b}

Model Year	Pollutant (g/hp·hr)			
	HC	CO	NO _x	NO _x + NMHC
1985-1987	1.1	14.4	10.6	—
1988-1990	1.1	14.4	6.0	—
1991-1997	1.1	14.4	5.0	—
1998-2004 ^c	1.1	14.4	4.0	—
2005-2007	—	14.4	—	1.0 ^d

^aStandards applied only for gasoline-fueled engines through model year 1989. Standards started to apply for methanol in model year 1990, and for LPG and natural gas in model year 1998.

^bEngines intended for installation only in heavy-duty vehicles above 14,000 pounds GVWR were subject to an HC standard of 1.9 g/hp·hr for model years 1987 through 2004, and a CO standard of 37.1 g/hp·hr for model years 1987 through 2007. In addition, for model years 1987 through 2007, up to 5 percent of a manufacturer's sales of engines intended for installation in heavy-duty vehicles at or below 14,000 pounds GVWR could be certified to the alternative HC and CO standards.

^cFor natural gas engines in model years 1998 through 2004, the NO_x standard was 5.0 g/hp·hr; the HC standards were 1.7 g/hp·hr for engines intended for installation only in vehicles above 14,000 pounds GVWR, and 0.9 g/hp·hr for other engines.

^dManufacturers could delay the 1.0 g/hp·hr NO_x + NMHC standard until model year 2008 by meeting an alternate NO_x + NMHC standard of 1.5 g/hp·hr applied for model years 2004 through 2007.

(f) *Transient emission standards for compression-ignition engines.* The following criteria standards applied for compression-ignition engines based on transient measurement using the test procedures in 40 CFR part 86, subpart N. Starting in model year 1991, manufacturers could generate or use emission credits for NO_x, NO_x + NMHC, and PM standards. Table 3 to this appendix follows:

Table 3 ~~to~~ of Appendix A—Transient Emission Standards for Compression-Ignition Engines^a

Model Year	Pollutant (g/hp·hr)				
	HC	CO	NO _x	NO _x + NMHC	PM
1985-1987	1.3	15.5	10.7	—	—
1988-1989	1.3	15.5	10.7	—	0.60
1990	1.3	15.5	6.0	—	0.60
1991-1992	1.3	15.5	5.0	—	0.25
1993	1.3	15.5	5.0	—	0.25 truck 0.10 bus
1994-1995	1.3	15.5	5.0	—	0.10 truck 0.07 urban bus
1996-1997	1.3	15.5	5.0	—	0.10 truck 0.05 urban bus ^b
1998-2003	1.3	15.5	4.0	—	0.10 truck 0.05 urban bus ^b
2004-2006	—	15.5	—	2.4 ^c	0.10 truck 0.05 urban bus ^b

^aStandards applied only for diesel-fueled engines through model year 1989. Standards started to apply for methanol in model year 1990, and for LPG and natural gas in model year 1997. An alternate HC standard of 1.2 g/hp·hr applied for natural gas engines for model years 1997 through 2003.

^bThe in-use PM standard for urban bus engines in model years 1996 through 2006 was 0.07 g/hp·hr.

^cAn optional NO_x + NMHC standard of 2.5 g/hp·hr applied in 2004 through 2006 in conjunction with a separate NMHC standard of 0.5 g/hp·hr.

Appendix B to of Part 1036—Transient Duty Cycles

(a) This appendix specifies transient duty cycles for the engine and powertrain testing described in §§ 1036.510 and 1036.512, as follows:

(1) The transient duty cycle for testing engines involves a schedule of normalized engine speed and torque values.

(2) The transient duty cycles for powertrain testing involves a schedule of vehicle speeds and road grade. Determine road grade at each point based on the peak rated power of the powertrain system, P_{rated} , determined in § 1036.527 and road grade coefficients using the following equation: $Road\ grade = a \cdot P_{\text{rated}}^2 + b \cdot P_{\text{rated}} + c$

(b) The following transient duty cycle applies for spark-ignition engines and powertrains:

Table 1 of Appendix B—Transient Duty Cycle for Spark-Ignition Engines and Powertrains

Record (seconds)	Engine testing		Vehicle speed (mi/hr)	Powertrain testing		
	Normalized revolutions per minute (percent)	Normalized torque (percent)		Road grade coefficients		
				<i>a</i>	<i>b</i>	<i>c</i>
1	0	0	0	0	0	0
2	0	0	0	0	0	0
3	0	0	0	1.837E-05	-1.876E-02	2.369E+00
4	0	0	0	2.756E-05	-2.814E-02	3.553E+00
24	0	0	0	2.756E-05	-2.814E-02	3.553E+00
25	7	44.4	0	2.756E-05	-2.814E-02	3.553E+00
26	16	85.4	3.04	2.756E-05	-2.814E-02	3.553E+00
27	27	97.8	5.59	2.756E-05	-2.814E-02	3.553E+00
28	38	100	8.37	2.756E-05	-2.814E-02	3.553E+00
29	45	100	11.06	2.756E-05	-2.814E-02	3.553E+00
30	51	100	13.63	2.756E-05	-2.814E-02	3.553E+00
31	54	97.5	15.87	2.756E-05	-2.814E-02	3.553E+00
32	53	90	18.09	2.756E-05	-2.814E-02	3.553E+00
33	49	75.2	20.66	2.756E-05	-2.814E-02	3.553E+00
34	45	50	22.26	9.186E-06	-9.380E-03	1.184E+00
35	40	10	22.08	-9.186E-06	9.380E-03	-1.184E+00
36	34	2.3	20.58	-2.756E-05	2.814E-02	-3.553E+00
37	27	0	18.65	-2.756E-05	2.814E-02	-3.553E+00
38	21	2.3	16.5	-2.756E-05	2.814E-02	-3.553E+00
39	16	12	14.19	-2.756E-05	2.814E-02	-3.553E+00
40	12	35.3	11.65	-2.756E-05	2.814E-02	-3.553E+00
41	8.5	4.9	9.16	-2.756E-05	2.814E-02	-3.553E+00
42	5	(^a)	8.01	-2.756E-05	2.814E-02	-3.553E+00
43	3	(^a)	6.86	-2.756E-05	2.814E-02	-3.553E+00
44	0	0	3.19	-2.756E-05	2.814E-02	-3.553E+00
45	0	0	0	-2.756E-05	2.814E-02	-3.553E+00
46	0	0	0	-2.756E-05	2.814E-02	-3.553E+00
47	0	0	0	-1.587E-05	1.622E-02	-2.202E+00
48	0	0	0	-4.187E-06	4.310E-03	-8.511E-01
49	0	0	0	7.498E-06	-7.604E-03	5.001E-01
50	0	0	0	7.498E-06	-7.604E-03	5.001E-01
51	3	10	1.05	7.498E-06	-7.604E-03	5.001E-01
52	11	40.2	2.13	7.498E-06	-7.604E-03	5.001E-01
53	20	53	3.26	7.498E-06	-7.604E-03	5.001E-01
54	27.5	64.8	4.31	7.498E-06	-7.604E-03	5.001E-01
55	32	78	5.35	7.498E-06	-7.604E-03	5.001E-01
56	32	78	6.38	7.498E-06	-7.604E-03	5.001E-01
57	27.5	56	7.42	7.498E-06	-7.604E-03	5.001E-01
58	26	24.4	8.45	7.498E-06	-7.604E-03	5.001E-01
59	24	(^a)	9.43	7.498E-06	-7.604E-03	5.001E-01
60	23	(^a)	10.18	7.498E-06	-7.604E-03	5.001E-01
61	24	(^a)	10.71	7.498E-06	-7.604E-03	5.001E-01
62	27	(^a)	11.1	7.498E-06	-7.604E-03	5.001E-01
63	34	(^a)	11.62	7.498E-06	-7.604E-03	5.001E-01
64	44	28	12.44	7.498E-06	-7.604E-03	5.001E-01

65	57	74.4	13.55	7.498E-06	-7.604E-03	5.001E-01
66	60	74.4	14.69	7.498E-06	-7.604E-03	5.001E-01
67	53	33.6	15.42	7.498E-06	-7.604E-03	5.001E-01
68	48	(^a)	16.06	7.498E-06	-7.604E-03	5.001E-01
69	44	(^a)	16.64	7.498E-06	-7.604E-03	5.001E-01
70	40	(^a)	17.36	8.991E-06	-9.177E-03	2.234E+00
71	40	7	17.86	1.048E-05	-1.075E-02	3.968E+00
72	44	22.7	18.05	1.198E-05	-1.232E-02	5.701E+00
73	46	30	18.09	1.198E-05	-1.232E-02	5.701E+00
74	46	32	18.19	1.198E-05	-1.232E-02	5.701E+00
75	44	25	18.55	1.198E-05	-1.232E-02	5.701E+00
76	40	18	19.04	1.198E-05	-1.232E-02	5.701E+00
77	37	14	19.58	1.198E-05	-1.232E-02	5.701E+00
78	36	10	19.9	1.198E-05	-1.232E-02	5.701E+00
79	34	0	19.99	1.198E-05	-1.232E-02	5.701E+00
80	34	(^a)	19.85	1.198E-05	-1.232E-02	5.701E+00
81	32	(^a)	19.73	1.198E-05	-1.232E-02	5.701E+00
82	31	(^a)	19.7	1.198E-05	-1.232E-02	5.701E+00
83	36	39.9	19.84	1.198E-05	-1.232E-02	5.701E+00
84	42	84.7	20.1	1.198E-05	-1.232E-02	5.701E+00
85	48	90	20.44	1.198E-05	-1.232E-02	5.701E+00
86	50	90	20.98	1.198E-05	-1.232E-02	5.701E+00
87	50	90	21.52	1.198E-05	-1.232E-02	5.701E+00
88	47	85	22.06	1.198E-05	-1.232E-02	5.701E+00
89	43	75	22.24	1.198E-05	-1.232E-02	5.701E+00
90	38	60	22.35	1.198E-05	-1.232E-02	5.701E+00
91	36	36	22.37	3.992E-06	-4.107E-03	1.900E+00
92	36	7.5	22.35	-3.992E-06	4.107E-03	-1.900E+00
93	36.3	(^a)	22.27	-1.198E-05	1.232E-02	-5.701E+00
94	45	64.5	22.05	-1.198E-05	1.232E-02	-5.701E+00
95	53	67	21.79	-1.198E-05	1.232E-02	-5.701E+00
96	58	64.5	21.5	-1.198E-05	1.232E-02	-5.701E+00
97	62	60.3	21.2	-1.198E-05	1.232E-02	-5.701E+00
98	63	55.5	20.9	-1.198E-05	1.232E-02	-5.701E+00
99	62	52.3	20.59	-1.198E-05	1.232E-02	-5.701E+00
100	61	47	20.42	-1.198E-05	1.232E-02	-5.701E+00
101	55	44	20.25	-1.198E-05	1.232E-02	-5.701E+00
102	50	39	20.07	-1.198E-05	1.232E-02	-5.701E+00
103	45	36	19.75	-1.198E-05	1.232E-02	-5.701E+00
104	40	34	19.38	-1.198E-05	1.232E-02	-5.701E+00
105	36	30	19	-1.198E-05	1.232E-02	-5.701E+00
106	34	25.8	18.61	-1.198E-05	1.232E-02	-5.701E+00
107	32	20	18.2	-1.198E-05	1.232E-02	-5.701E+00
108	30	14.6	17.75	-1.198E-05	1.232E-02	-5.701E+00
109	26	10	17.27	-1.198E-05	1.232E-02	-5.701E+00
110	23	0	16.75	-1.198E-05	1.232E-02	-5.701E+00
111	18	(^a)	16.2	-1.198E-05	1.232E-02	-5.701E+00
112	16	(^a)	15.66	-1.198E-05	1.232E-02	-5.701E+00
113	18	(^a)	15.15	-1.198E-05	1.232E-02	-5.701E+00
114	20	27.6	14.65	-1.198E-05	1.232E-02	-5.701E+00
115	17	4	14.16	-1.198E-05	1.232E-02	-5.701E+00
116	14	(^a)	13.67	-1.198E-05	1.232E-02	-5.701E+00
117	12	(^a)	12.59	-1.198E-05	1.232E-02	-5.701E+00
118	9	(^a)	10.93	-1.198E-05	1.232E-02	-5.701E+00
119	7	(^a)	9.28	-1.198E-05	1.232E-02	-5.701E+00
120	7	(^a)	7.62	-1.198E-05	1.232E-02	-5.701E+00
121	5	(^a)	5.96	-1.198E-05	1.232E-02	-5.701E+00
122	4	(^a)	4.3	-1.198E-05	1.232E-02	-5.701E+00
123	3	(^a)	2.64	-1.198E-05	1.232E-02	-5.701E+00
124	2	(^a)	0.99	-1.198E-05	1.232E-02	-5.701E+00
125	0	0	0.19	-1.198E-05	1.232E-02	-5.701E+00
126	0	0	0	-1.198E-05	1.232E-02	-5.701E+00
127	0	0	0	-1.198E-05	1.232E-02	-5.701E+00
128	0	0	0	5.354E-07	1.492E-03	-6.315E+00
129	0	0	0	1.305E-05	-9.337E-03	-6.929E+00
130	5	8	3.25	2.556E-05	-2.017E-02	-7.543E+00

131	8	16.3	5.47	2.556E-05	-2.017E-02	-7.543E+00
132	10	27.5	6.71	2.556E-05	-2.017E-02	-7.543E+00
133	8	27.5	6.71	2.556E-05	-2.017E-02	-7.543E+00
134	5	9	6.71	2.556E-05	-2.017E-02	-7.543E+00
135	2	1.8	6.55	8.520E-06	-6.722E-03	-2.514E+00
136	0	0	6.01	-8.520E-06	6.722E-03	2.514E+00
137	0	0	5.15	-2.556E-05	2.017E-02	7.543E+00
138	0	0	3.9	-2.556E-05	2.017E-02	7.543E+00
139	0	0	2.19	-2.556E-05	2.017E-02	7.543E+00
140	0	0	0	-2.556E-05	2.017E-02	7.543E+00
141	0	0	0	-9.124E-06	5.441E-03	6.132E+00
142	0	0	0	7.313E-06	-9.284E-03	4.722E+00
143	0	0	0	2.375E-05	-2.401E-02	3.312E+00
148	0	0	0	2.375E-05	-2.401E-02	3.312E+00
149	2	4.8	0	2.375E-05	-2.401E-02	3.312E+00
150	1	4.5	0	2.375E-05	-2.401E-02	3.312E+00
151	0	0	0	2.375E-05	-2.401E-02	3.312E+00
166	0	0	0	2.375E-05	-2.401E-02	3.312E+00
167	8	27	1.95	2.375E-05	-2.401E-02	3.312E+00
168	18	65	3.7	2.375E-05	-2.401E-02	3.312E+00
169	23	82.5	5.53	2.375E-05	-2.401E-02	3.312E+00
170	23	88	7.22	2.375E-05	-2.401E-02	3.312E+00
171	21	88	8.64	2.375E-05	-2.401E-02	3.312E+00
172	18	81.3	10.33	2.375E-05	-2.401E-02	3.312E+00
173	17	32	11.18	7.917E-06	-8.003E-03	1.104E+00
174	15	(^a)	10.57	-7.917E-06	8.003E-03	-1.104E+00
175	13	(^a)	9.33	-2.375E-05	2.401E-02	-3.312E+00
176	11	(^a)	7.87	-2.375E-05	2.401E-02	-3.312E+00
177	8	(^a)	6.27	-2.375E-05	2.401E-02	-3.312E+00
178	6	(^a)	4.58	-2.375E-05	2.401E-02	-3.312E+00
179	4	(^a)	3.81	-2.375E-05	2.401E-02	-3.312E+00
180	2	(^a)	2.35	-2.375E-05	2.401E-02	-3.312E+00
181	0	0	0	-2.375E-05	2.401E-02	-3.312E+00
182	0	0	0	-2.375E-05	2.401E-02	-3.312E+00
183	0	0	0	-1.078E-05	1.103E-02	-1.145E+00
184	0	0	0	2.190E-06	-1.954E-03	1.022E+00
185	0	0	0	1.516E-05	-1.494E-02	3.189E+00
203	0	0	0	1.516E-05	-1.494E-02	3.189E+00
204	0	4	0	1.516E-05	-1.494E-02	3.189E+00
205	0.5	7.7	1.6	1.516E-05	-1.494E-02	3.189E+00
206	5	14	4.24	1.516E-05	-1.494E-02	3.189E+00
207	11	24.7	7.5	1.516E-05	-1.494E-02	3.189E+00
208	15	42.3	9.18	1.516E-05	-1.494E-02	3.189E+00
209	16	70	10.11	1.516E-05	-1.494E-02	3.189E+00
210	17	70	10.34	1.516E-05	-1.494E-02	3.189E+00
211	17	50	10.46	1.516E-05	-1.494E-02	3.189E+00
212	16	26.3	9.93	1.516E-05	-1.494E-02	3.189E+00
213	14	5	8.7	1.516E-05	-1.494E-02	3.189E+00
214	10	(^a)	7.43	1.516E-05	-1.494E-02	3.189E+00
215	10	(^a)	9.14	1.516E-05	-1.494E-02	3.189E+00
216	14	73.3	9.72	1.516E-05	-1.494E-02	3.189E+00
217	18	83	9.84	1.516E-05	-1.494E-02	3.189E+00
218	19	84.8	10.02	1.516E-05	-1.494E-02	3.189E+00
219	18	84.8	9.92	5.053E-06	-4.979E-03	1.063E+00
220	16	82.8	9.14	-5.053E-06	4.979E-03	-1.063E+00
221	11	74	8.23	-1.516E-05	1.494E-02	-3.189E+00
222	7	8.5	6.64	-1.516E-05	1.494E-02	-3.189E+00
223	4	0	4.51	-1.516E-05	1.494E-02	-3.189E+00
224	0	0	0	-1.516E-05	1.494E-02	-3.189E+00
225	0	0	0	-1.516E-05	1.494E-02	-3.189E+00
226	0	0	0	-6.857E-06	6.357E-03	-2.057E+00
227	0	0	0	1.446E-06	-2.223E-03	-9.251E-01
228	0	0	0	9.749E-06	-1.080E-02	2.071E-01
232	0	0	0	9.749E-06	-1.080E-02	2.071E-01
233	6	17.6	0	9.749E-06	-1.080E-02	2.071E-01
234	6	19.6	0	9.749E-06	-1.080E-02	2.071E-01

235	5	14	0	9.749E-06	-1.080E-02	2.071E-01
236	3	9.8	0	9.749E-06	-1.080E-02	2.071E-01
237	1	5.5	0	9.749E-06	-1.080E-02	2.071E-01
238	0	3	0	9.749E-06	-1.080E-02	2.071E-01
239	0	0	0	9.749E-06	-1.080E-02	2.071E-01
280	0	0	0	9.749E-06	-1.080E-02	2.071E-01
281	0	7	0	9.749E-06	-1.080E-02	2.071E-01
282	1	10	0	9.749E-06	-1.080E-02	2.071E-01
283	2	11.5	0	9.749E-06	-1.080E-02	2.071E-01
284	1	10	0	9.749E-06	-1.080E-02	2.071E-01
285	0	0	0	9.749E-06	-1.080E-02	2.071E-01
298	0	0	0	9.749E-06	-1.080E-02	2.071E-01
299	0	28	0	9.749E-06	-1.080E-02	2.071E-01
300	0	30	0	9.749E-06	-1.080E-02	2.071E-01
301	2	32	0.55	9.749E-06	-1.080E-02	2.071E-01
302	6	34	1.92	9.749E-06	-1.080E-02	2.071E-01
303	14	36	3.18	9.749E-06	-1.080E-02	2.071E-01
304	19	36	4.8	9.749E-06	-1.080E-02	2.071E-01
305	24.5	36	6.63	9.749E-06	-1.080E-02	2.071E-01
306	24.5	36	7.87	9.749E-06	-1.080E-02	2.071E-01
307	24	30	8.32	9.749E-06	-1.080E-02	2.071E-01
308	19	24	9.66	9.749E-06	-1.080E-02	2.071E-01
309	13	18	11.46	9.749E-06	-1.080E-02	2.071E-01
310	9	14	13.28	9.749E-06	-1.080E-02	2.071E-01
311	7	8	14.61	9.749E-06	-1.080E-02	2.071E-01
312	6	0	14.39	9.749E-06	-1.080E-02	2.071E-01
313	4	3	13.5	9.749E-06	-1.080E-02	2.071E-01
314	3	6.8	12.41	9.749E-06	-1.080E-02	2.071E-01
315	0	0	11.3	9.749E-06	-1.080E-02	2.071E-01
316	0	0	11.25	9.749E-06	-1.080E-02	2.071E-01
317	0	0	12.29	9.749E-06	-1.080E-02	2.071E-01
318	0	0	13.26	9.749E-06	-1.080E-02	2.071E-01
319	0	0	13.66	9.749E-06	-1.080E-02	2.071E-01
320	0	0	14.27	9.749E-06	-1.080E-02	2.071E-01
321	0	0	15.17	9.749E-06	-1.080E-02	2.071E-01
322	0	0	16.05	9.749E-06	-1.080E-02	2.071E-01
323	0	18	16.49	9.749E-06	-1.080E-02	2.071E-01
324	3	40	17.52	9.749E-06	-1.080E-02	2.071E-01
325	8	86	18.06	9.749E-06	-1.080E-02	2.071E-01
326	18	97	18.18	9.749E-06	-1.080E-02	2.071E-01
327	38	100	18.95	9.749E-06	-1.080E-02	2.071E-01
328	45.5	100	20.48	9.749E-06	-1.080E-02	2.071E-01
329	45	96	20.48	3.250E-06	-3.601E-03	6.902E-02
330	44	84.4	19.5	-3.250E-06	3.601E-03	-6.902E-02
331	43	53.6	18.43	-9.749E-06	1.080E-02	-2.071E-01
332	41	5	17.44	-9.749E-06	1.080E-02	-2.071E-01
333	43	47.6	16.77	-9.749E-06	1.080E-02	-2.071E-01
334	44	90	16.36	-9.749E-06	1.080E-02	-2.071E-01
335	45	90	16.34	-9.749E-06	1.080E-02	-2.071E-01
336	44	73	16.79	-9.749E-06	1.080E-02	-2.071E-01
337	40	54	16.34	-9.749E-06	1.080E-02	-2.071E-01
338	38	34.7	15.13	-9.749E-06	1.080E-02	-2.071E-01
339	36	10	13.72	-9.749E-06	1.080E-02	-2.071E-01
340	35	10	12.04	-9.749E-06	1.080E-02	-2.071E-01
341	35	10	10.44	-9.749E-06	1.080E-02	-2.071E-01
342	35.5	60	9.71	-9.749E-06	1.080E-02	-2.071E-01
343	36	57.9	9.81	-9.749E-06	1.080E-02	-2.071E-01
344	37	53	10.65	-9.749E-06	1.080E-02	-2.071E-01
345	39	50	11.42	-9.749E-06	1.080E-02	-2.071E-01
346	40.5	50	10.54	-9.749E-06	1.080E-02	-2.071E-01
347	43	50	8.87	-9.749E-06	1.080E-02	-2.071E-01
348	45	50	9.26	-3.250E-06	3.601E-03	-6.902E-02
349	48	50	10.33	3.250E-06	-3.601E-03	6.902E-02
350	51	52	10.79	9.749E-06	-1.080E-02	2.071E-01
351	56	58.7	11.8	9.749E-06	-1.080E-02	2.071E-01
352	64	70	14.06	9.749E-06	-1.080E-02	2.071E-01

353	68	70	16.77	9.749E-06	-1.080E-02	2.071E-01
354	70	70	18.83	9.749E-06	-1.080E-02	2.071E-01
355	65.5	64.6	22.12	9.749E-06	-1.080E-02	2.071E-01
356	61	28.9	24.1	9.749E-06	-1.080E-02	2.071E-01
357	55	(^a)	25.97	9.749E-06	-1.080E-02	2.071E-01
358	50	(^a)	27.04	9.749E-06	-1.080E-02	2.071E-01
359	45	(^a)	27.18	9.749E-06	-1.080E-02	2.071E-01
360	38	(^a)	28.34	9.749E-06	-1.080E-02	2.071E-01
361	28	(^a)	29.69	9.749E-06	-1.080E-02	2.071E-01
362	19	(^a)	29.86	9.749E-06	-1.080E-02	2.071E-01
363	14	(^a)	29.51	9.749E-06	-1.080E-02	2.071E-01
364	7	(^a)	29.91	9.749E-06	-1.080E-02	2.071E-01
365	2	(^a)	30.99	9.749E-06	-1.080E-02	2.071E-01
366	3	5	32.55	9.749E-06	-1.080E-02	2.071E-01
367	7	25	33.43	9.749E-06	-1.080E-02	2.071E-01
368	9	38	33.56	3.250E-06	-3.601E-03	6.902E-02
369	7	17	33.36	-3.250E-06	3.601E-03	-6.902E-02
370	4	2	32.65	-9.749E-06	1.080E-02	-2.071E-01
371	3	(^a)	31.8	-9.749E-06	1.080E-02	-2.071E-01
372	3	(^a)	30.92	-9.749E-06	1.080E-02	-2.071E-01
373	11	70	30.42	-9.749E-06	1.080E-02	-2.071E-01
374	15	97.6	29.73	-9.749E-06	1.080E-02	-2.071E-01
375	16	100	28.65	-9.749E-06	1.080E-02	-2.071E-01
376	19	100	27.5	-9.749E-06	1.080E-02	-2.071E-01
377	26	100	26.22	-9.749E-06	1.080E-02	-2.071E-01
378	29	95	24.69	-9.749E-06	1.080E-02	-2.071E-01
379	25	63	23.13	-9.749E-06	1.080E-02	-2.071E-01
380	19	(^a)	21.68	-9.749E-06	1.080E-02	-2.071E-01
381	12	(^a)	20.25	-9.749E-06	1.080E-02	-2.071E-01
382	8	(^a)	15.73	-9.749E-06	1.080E-02	-2.071E-01
383	5	(^a)	10.93	-9.749E-06	1.080E-02	-2.071E-01
384	2	(^a)	6.12	-9.749E-06	1.080E-02	-2.071E-01
385	1	(^a)	1.31	-9.749E-06	1.080E-02	-2.071E-01
386	0	0	0	-9.749E-06	1.080E-02	-2.071E-01
392	0	0	0	-9.749E-06	1.080E-02	-2.071E-01
393	0	0	0	-1.165E-06	1.625E-03	1.971E+00
394	0	0	0	7.420E-06	-7.553E-03	4.149E+00
395	0	0	0	1.600E-05	-1.673E-02	6.327E+00
418	0	0	0	1.600E-05	-1.673E-02	6.327E+00
419	4	20	0	1.600E-05	-1.673E-02	6.327E+00
420	4	20	0	1.600E-05	-1.673E-02	6.327E+00
421	0	0	0	1.600E-05	-1.673E-02	6.327E+00
429	0	0	0	1.600E-05	-1.673E-02	6.327E+00
430	2	0	1.18	1.600E-05	-1.673E-02	6.327E+00
431	6	2	2.85	1.600E-05	-1.673E-02	6.327E+00
432	14	28.8	4.57	1.600E-05	-1.673E-02	6.327E+00
433	20	30	7.42	1.600E-05	-1.673E-02	6.327E+00
434	24.4	11	10.79	1.600E-05	-1.673E-02	6.327E+00
435	24	10	13.51	1.600E-05	-1.673E-02	6.327E+00
436	24	12	15.48	1.600E-05	-1.673E-02	6.327E+00
437	28	52	16.82	1.600E-05	-1.673E-02	6.327E+00
438	32	52	17.86	1.600E-05	-1.673E-02	6.327E+00
439	34	46	18.7	1.600E-05	-1.673E-02	6.327E+00
440	34	30	19.11	1.600E-05	-1.673E-02	6.327E+00
441	34.5	30	19.28	1.600E-05	-1.673E-02	6.327E+00
442	35	30	19.38	1.600E-05	-1.673E-02	6.327E+00
443	36	35	19.53	1.600E-05	-1.673E-02	6.327E+00
444	39	40	19.57	1.600E-05	-1.673E-02	6.327E+00
445	45	50	19.09	1.600E-05	-1.673E-02	6.327E+00
446	49	56	18.2	1.600E-05	-1.673E-02	6.327E+00
447	50	(^a)	17.14	1.600E-05	-1.673E-02	6.327E+00
448	45	(^a)	15.9	1.600E-05	-1.673E-02	6.327E+00
449	39	(^a)	14.42	1.600E-05	-1.673E-02	6.327E+00
450	34	(^a)	13.86	1.600E-05	-1.673E-02	6.327E+00
451	28	(^a)	15.45	1.600E-05	-1.673E-02	6.327E+00
452	25	(^a)	17.32	1.600E-05	-1.673E-02	6.327E+00

453	21	(^a)	18.03	1.600E-05	-1.673E-02	6.327E+00
454	18	(^a)	18.19	1.600E-05	-1.673E-02	6.327E+00
455	15	(^a)	18.3	1.600E-05	-1.673E-02	6.327E+00
456	12	(^a)	18.4	1.600E-05	-1.673E-02	6.327E+00
457	18	(^a)	18.33	1.600E-05	-1.673E-02	6.327E+00
458	29	19.8	18.68	1.600E-05	-1.673E-02	6.327E+00
459	40	54	19.1	5.335E-06	-5.577E-03	2.109E+00
460	52	82	18.69	-5.335E-06	5.577E-03	-2.109E+00
461	64	95	17.89	-1.600E-05	1.673E-02	-6.327E+00
462	71	99	17.23	-1.600E-05	1.673E-02	-6.327E+00
463	77	100	16.65	-1.600E-05	1.673E-02	-6.327E+00
464	84	100	15.76	-1.600E-05	1.673E-02	-6.327E+00
465	85	99	14.53	-1.600E-05	1.673E-02	-6.327E+00
466	85	95	13.07	-1.600E-05	1.673E-02	-6.327E+00
467	84	90	11.26	-1.600E-05	1.673E-02	-6.327E+00
468	82	84.6	9.32	-1.600E-05	1.673E-02	-6.327E+00
469	80	78.5	8.04	-1.600E-05	1.673E-02	-6.327E+00
470	78	78.5	8.15	-7.218E-06	7.554E-03	-2.785E+00
471	77	70	9.43	1.567E-06	-1.623E-03	7.568E-01
472	76	65.5	10.8	1.035E-05	-1.080E-02	4.299E+00
473	74	61.5	12.16	1.035E-05	-1.080E-02	4.299E+00
474	72	56	14.25	1.035E-05	-1.080E-02	4.299E+00
475	70	52	16.38	1.035E-05	-1.080E-02	4.299E+00
476	68	46	17.48	1.035E-05	-1.080E-02	4.299E+00
477	66.5	40	17.41	1.035E-05	-1.080E-02	4.299E+00
478	65	32	16.78	1.035E-05	-1.080E-02	4.299E+00
479	63	26	16.06	1.035E-05	-1.080E-02	4.299E+00
480	61	25.6	15.24	1.035E-05	-1.080E-02	4.299E+00
481	61	72	14.69	1.035E-05	-1.080E-02	4.299E+00
482	61	78	15.38	1.035E-05	-1.080E-02	4.299E+00
483	58	72	16.86	1.035E-05	-1.080E-02	4.299E+00
484	50	64	17.35	1.035E-05	-1.080E-02	4.299E+00
485	44	55	16.98	1.035E-05	-1.080E-02	4.299E+00
486	35	40	16.57	1.035E-05	-1.080E-02	4.299E+00
487	26	20	16.12	1.035E-05	-1.080E-02	4.299E+00
488	21	(^a)	15.67	1.035E-05	-1.080E-02	4.299E+00
489	18	(^a)	15.46	1.035E-05	-1.080E-02	4.299E+00
490	16	(^a)	15.52	1.035E-05	-1.080E-02	4.299E+00
491	19	(^a)	15.89	1.035E-05	-1.080E-02	4.299E+00
492	24	2	16.77	1.035E-05	-1.080E-02	4.299E+00
493	32	68.5	18.08	1.035E-05	-1.080E-02	4.299E+00
494	45	78	19.31	1.035E-05	-1.080E-02	4.299E+00
495	51	86	20.11	1.035E-05	-1.080E-02	4.299E+00
496	58	92	20.75	1.035E-05	-1.080E-02	4.299E+00
497	64	97	21.23	1.035E-05	-1.080E-02	4.299E+00
498	71	100	21.4	1.035E-05	-1.080E-02	4.299E+00
499	73	98	21.51	1.035E-05	-1.080E-02	4.299E+00
500	73	94	22.18	1.035E-05	-1.080E-02	4.299E+00
501	73	86	22.48	1.035E-05	-1.080E-02	4.299E+00
502	73	82	22.49	1.035E-05	-1.080E-02	4.299E+00
503	76	84	23.27	1.035E-05	-1.080E-02	4.299E+00
504	80	98	24.39	1.035E-05	-1.080E-02	4.299E+00
505	84	100	25.09	1.035E-05	-1.080E-02	4.299E+00
506	85	100	25.26	1.035E-05	-1.080E-02	4.299E+00
507	84	100	25.15	1.035E-05	-1.080E-02	4.299E+00
508	81	92	24.8	1.035E-05	-1.080E-02	4.299E+00
509	75	80	24.3	1.035E-05	-1.080E-02	4.299E+00
510	73	70	23.92	1.035E-05	-1.080E-02	4.299E+00
511	70	60	23.82	1.035E-05	-1.080E-02	4.299E+00
512	67	53	23.75	1.035E-05	-1.080E-02	4.299E+00
513	65	45	24.34	1.035E-05	-1.080E-02	4.299E+00
514	63	36.5	25.03	1.035E-05	-1.080E-02	4.299E+00
515	62	28	25.13	1.035E-05	-1.080E-02	4.299E+00
516	61	22.5	25.14	1.035E-05	-1.080E-02	4.299E+00
517	60	23	25.14	1.035E-05	-1.080E-02	4.299E+00
518	60	24	25.15	1.035E-05	-1.080E-02	4.299E+00

519	60	24	25.15	1.035E-05	-1.080E-02	4.299E+00
520	60	26	25.16	1.035E-05	-1.080E-02	4.299E+00
521	61	60	25.17	1.035E-05	-1.080E-02	4.299E+00
522	62	64	25.24	1.035E-05	-1.080E-02	4.299E+00
523	63	64	25.41	1.035E-05	-1.080E-02	4.299E+00
524	64	64	26.56	1.035E-05	-1.080E-02	4.299E+00
525	62	64	28.84	1.035E-05	-1.080E-02	4.299E+00
526	56	60	31.08	1.035E-05	-1.080E-02	4.299E+00
527	53	(^a)	32.37	1.035E-05	-1.080E-02	4.299E+00
528	49	(^a)	32.7	1.035E-05	-1.080E-02	4.299E+00
529	47	(^a)	32.76	1.035E-05	-1.080E-02	4.299E+00
530	46	(^a)	32.82	6.288E-06	-6.906E-03	2.331E+00
531	45	(^a)	32.88	2.223E-06	-3.012E-03	3.623E-01
532	45	30	33.19	-1.842E-06	8.816E-04	-1.606E+00
533	46	50	33.89	-1.842E-06	8.816E-04	-1.606E+00
534	46	50	35.07	-1.842E-06	8.816E-04	-1.606E+00
535	47	50	36.61	-1.842E-06	8.816E-04	-1.606E+00
536	47	50	37.63	-1.842E-06	8.816E-04	-1.606E+00
537	47	30	38.05	-1.842E-06	8.816E-04	-1.606E+00
538	46	12	38.67	-1.842E-06	8.816E-04	-1.606E+00
539	45	10.5	39.32	-1.842E-06	8.816E-04	-1.606E+00
540	44	10	39.54	-1.842E-06	8.816E-04	-1.606E+00
541	41	10	39.55	-1.842E-06	8.816E-04	-1.606E+00
542	37	9	39.56	-1.842E-06	8.816E-04	-1.606E+00
543	36	2	39.58	-1.842E-06	8.816E-04	-1.606E+00
544	35	(^a)	39.59	-1.842E-06	8.816E-04	-1.606E+00
545	38	67	39.61	-1.842E-06	8.816E-04	-1.606E+00
546	35	(^a)	39.6	-1.842E-06	8.816E-04	-1.606E+00
547	31	15	39.69	-1.842E-06	8.816E-04	-1.606E+00
548	28	55	39.99	-1.842E-06	8.816E-04	-1.606E+00
549	34	44	40.39	-1.842E-06	8.816E-04	-1.606E+00
550	35	38.5	41.01	-1.842E-06	8.816E-04	-1.606E+00
551	36	38.5	41.65	-1.842E-06	8.816E-04	-1.606E+00
552	36	38.5	41.69	-1.842E-06	8.816E-04	-1.606E+00
553	37	38.5	41.17	-1.842E-06	8.816E-04	-1.606E+00
554	39	36	40.47	-1.842E-06	8.816E-04	-1.606E+00
555	42	27	39.83	-1.842E-06	8.816E-04	-1.606E+00
556	45	62	39.39	-1.842E-06	8.816E-04	-1.606E+00
557	48	45	39.14	-1.842E-06	8.816E-04	-1.606E+00
558	51	15	38.99	-1.842E-06	8.816E-04	-1.606E+00
559	51	8	38.88	-1.842E-06	8.816E-04	-1.606E+00
560	51	6	38.86	-1.842E-06	8.816E-04	-1.606E+00
561	48	10	39.17	-1.842E-06	8.816E-04	-1.606E+00
562	46	11	39.37	-6.139E-07	2.939E-04	-5.353E-01
563	44	13	38.63	6.139E-07	-2.939E-04	5.353E-01
564	41	17	36.96	1.842E-06	-8.816E-04	1.606E+00
565	37	20	34.87	1.842E-06	-8.816E-04	1.606E+00
566	34	20	32.73	1.842E-06	-8.816E-04	1.606E+00
567	30	17	30.53	1.842E-06	-8.816E-04	1.606E+00
568	26	14	28.27	1.842E-06	-8.816E-04	1.606E+00
569	23	7	26.02	1.842E-06	-8.816E-04	1.606E+00
570	19	2	23.76	1.842E-06	-8.816E-04	1.606E+00
571	15	(^a)	21.37	1.842E-06	-8.816E-04	1.606E+00
572	11	(^a)	18.79	1.842E-06	-8.816E-04	1.606E+00
573	8	(^a)	16.06	1.842E-06	-8.816E-04	1.606E+00
574	5	(^a)	13.05	1.842E-06	-8.816E-04	1.606E+00
575	2	(^a)	9.54	1.842E-06	-8.816E-04	1.606E+00
576	0	0	4.59	1.842E-06	-8.816E-04	1.606E+00
577	0	0	0	1.842E-06	-8.816E-04	1.606E+00
580	0	0	0	1.842E-06	-8.816E-04	1.606E+00
581	0	0	0	8.289E-06	-7.507E-03	1.023E+00
582	0	0	0	1.474E-05	-1.413E-02	4.394E-01
583	4	15	0	2.118E-05	-2.076E-02	-1.439E-01
584	19	31	0.78	2.118E-05	-2.076E-02	-1.439E-01
585	30	46	1.94	2.118E-05	-2.076E-02	-1.439E-01
586	37	68	3.83	2.118E-05	-2.076E-02	-1.439E-01

587	40	76	5.98	2.118E-05	-2.076E-02	-1.439E-01
588	41	77	8.07	2.118E-05	-2.076E-02	-1.439E-01
589	40.5	78	10.09	2.118E-05	-2.076E-02	-1.439E-01
590	40	77	10.29	2.118E-05	-2.076E-02	-1.439E-01
591	40	64	7.34	2.118E-05	-2.076E-02	-1.439E-01
592	38	10	3.27	2.118E-05	-2.076E-02	-1.439E-01
593	38	25	3.24	2.118E-05	-2.076E-02	-1.439E-01
594	40	50	5.98	2.118E-05	-2.076E-02	-1.439E-01
595	40	36	8.48	2.118E-05	-2.076E-02	-1.439E-01
596	40	31	11	2.118E-05	-2.076E-02	-1.439E-01
597	40	31	13.62	2.118E-05	-2.076E-02	-1.439E-01
598	41	37	16.07	2.118E-05	-2.076E-02	-1.439E-01
599	42	97	18.51	2.118E-05	-2.076E-02	-1.439E-01
600	43	100	21.51	1.588E-05	-1.615E-02	-7.554E-01
601	45	100	24.71	1.058E-05	-1.153E-02	-1.367E+00
602	47	100	27.57	5.283E-06	-6.920E-03	-1.978E+00
603	48	100	30.04	5.283E-06	-6.920E-03	-1.978E+00
604	49	100	32.22	5.283E-06	-6.920E-03	-1.978E+00
605	51	97	34.28	5.283E-06	-6.920E-03	-1.978E+00
606	52	94	36.22	5.283E-06	-6.920E-03	-1.978E+00
607	53	90	38.08	5.283E-06	-6.920E-03	-1.978E+00
608	54	87	39.83	5.283E-06	-6.920E-03	-1.978E+00
609	56	86	41.63	5.283E-06	-6.920E-03	-1.978E+00
610	56	85	43.18	5.283E-06	-6.920E-03	-1.978E+00
611	55.5	85	44.33	5.283E-06	-6.920E-03	-1.978E+00
612	55	81	45.38	5.283E-06	-6.920E-03	-1.978E+00
613	54	77	46.14	5.283E-06	-6.920E-03	-1.978E+00
614	53	72	46.39	5.283E-06	-6.920E-03	-1.978E+00
615	52	67	46.34	5.283E-06	-6.920E-03	-1.978E+00
616	49	60	46.24	5.283E-06	-6.920E-03	-1.978E+00
617	46	45	46.14	5.283E-06	-6.920E-03	-1.978E+00
618	45	12	46.05	5.283E-06	-6.920E-03	-1.978E+00
619	44	10	46.13	5.283E-06	-6.920E-03	-1.978E+00
620	44	10	46.49	5.283E-06	-6.920E-03	-1.978E+00
621	45	12	46.78	5.283E-06	-6.920E-03	-1.978E+00
622	46	14	46.81	5.283E-06	-6.920E-03	-1.978E+00
623	47	24	46.95	5.283E-06	-6.920E-03	-1.978E+00
624	49	88	47.37	5.283E-06	-6.920E-03	-1.978E+00
625	50	90	47.62	2.349E-06	-3.713E-03	-1.409E+00
626	51	90	47.58	-5.848E-07	-5.058E-04	-8.401E-01
627	52	90	48	-3.519E-06	2.701E-03	-2.710E-01
628	53	90	48.46	-3.519E-06	2.701E-03	-2.710E-01
629	54	90	48.45	-3.519E-06	2.701E-03	-2.710E-01
630	54	90	48.4	-3.519E-06	2.701E-03	-2.710E-01
631	54	87	48.59	-3.519E-06	2.701E-03	-2.710E-01
632	54	84	49.3	-3.519E-06	2.701E-03	-2.710E-01
633	54	80	50.02	-3.519E-06	2.701E-03	-2.710E-01
634	53.5	77	50.27	-3.519E-06	2.701E-03	-2.710E-01
635	53	76	50	-3.519E-06	2.701E-03	-2.710E-01
636	53	75	49.73	-3.519E-06	2.701E-03	-2.710E-01
637	52	73	49.57	-3.519E-06	2.701E-03	-2.710E-01
638	51	69	49.31	-3.519E-06	2.701E-03	-2.710E-01
639	50	65	49.29	-3.519E-06	2.701E-03	-2.710E-01
640	50	60	49.71	-3.519E-06	2.701E-03	-2.710E-01
641	49	55	50.02	-3.519E-06	2.701E-03	-2.710E-01
642	49	50	50.05	-3.519E-06	2.701E-03	-2.710E-01
643	49	50	50.07	-3.519E-06	2.701E-03	-2.710E-01
644	49.5	60	50.33	-3.519E-06	2.701E-03	-2.710E-01
645	49.5	65	50.75	-3.519E-06	2.701E-03	-2.710E-01
646	50	70	51.03	-3.519E-06	2.701E-03	-2.710E-01
647	50.5	75	51.47	-3.519E-06	2.701E-03	-2.710E-01
648	51	80	51.92	-3.519E-06	2.701E-03	-2.710E-01
649	52	85	51.93	-3.519E-06	2.701E-03	-2.710E-01
650	53	90	51.9	-4.549E-06	3.697E-03	-6.366E-01
651	54	90	51.87	-5.579E-06	4.693E-03	-1.002E+00
652	55	90	51.85	-6.609E-06	5.688E-03	-1.368E+00

653	55	88	51.82	-6.609E-06	5.688E-03	-1.368E+00
654	55	84	51.82	-6.609E-06	5.688E-03	-1.368E+00
655	55	79	52.54	-6.609E-06	5.688E-03	-1.368E+00
656	55	74	53.59	-6.609E-06	5.688E-03	-1.368E+00
657	55	69	54.19	-6.609E-06	5.688E-03	-1.368E+00
658	55	64	54.26	-6.609E-06	5.688E-03	-1.368E+00
659	55	59	54.07	-6.609E-06	5.688E-03	-1.368E+00
660	55	54	53.93	-6.609E-06	5.688E-03	-1.368E+00
661	55	49	53.92	-6.609E-06	5.688E-03	-1.368E+00
662	55	44.5	53.9	-6.609E-06	5.688E-03	-1.368E+00
663	55	39	53.89	-6.609E-06	5.688E-03	-1.368E+00
664	55	34	53.88	-6.609E-06	5.688E-03	-1.368E+00
665	55	27	53.87	-6.609E-06	5.688E-03	-1.368E+00
666	55	18	53.85	-6.609E-06	5.688E-03	-1.368E+00
667	55	8	53.81	-6.609E-06	5.688E-03	-1.368E+00
668	55	6	53.67	-6.609E-06	5.688E-03	-1.368E+00
669	55	13	53.67	-6.609E-06	5.688E-03	-1.368E+00
670	55	27	54.32	-6.609E-06	5.688E-03	-1.368E+00
671	55.5	30	54.88	-6.609E-06	5.688E-03	-1.368E+00
672	56	30	54.87	-6.609E-06	5.688E-03	-1.368E+00
673	57	30	54.86	-6.609E-06	5.688E-03	-1.368E+00
674	58	34	54.75	-6.609E-06	5.688E-03	-1.368E+00
675	59	46	54.28	-5.500E-06	4.582E-03	-7.225E-01
676	59	89	53.84	-4.390E-06	3.477E-03	-7.706E-02
677	59	90	54.02	-3.280E-06	2.371E-03	5.683E-01
678	59	91	54.48	-3.280E-06	2.371E-03	5.683E-01
679	59	91	54.76	-3.280E-06	2.371E-03	5.683E-01
680	60	91	54.84	-3.280E-06	2.371E-03	5.683E-01
681	60	91	54.87	-3.280E-06	2.371E-03	5.683E-01
682	60.5	90	54.9	-3.280E-06	2.371E-03	5.683E-01
683	61	89	54.93	-3.280E-06	2.371E-03	5.683E-01
684	61.5	88	54.97	-3.280E-06	2.371E-03	5.683E-01
685	62	83	55	-3.280E-06	2.371E-03	5.683E-01
686	63	73	55.03	-3.280E-06	2.371E-03	5.683E-01
687	65	70	55.06	-3.280E-06	2.371E-03	5.683E-01
688	66	71	55.1	-3.280E-06	2.371E-03	5.683E-01
689	67	74	55.12	-3.280E-06	2.371E-03	5.683E-01
690	67.5	79	55.15	-3.280E-06	2.371E-03	5.683E-01
691	68	85	55.16	-3.280E-06	2.371E-03	5.683E-01
692	68.5	90	55.18	-3.280E-06	2.371E-03	5.683E-01
693	69	94	55.33	-3.280E-06	2.371E-03	5.683E-01
694	69.5	96	55.85	-3.280E-06	2.371E-03	5.683E-01
695	70	98	56.52	-3.280E-06	2.371E-03	5.683E-01
696	70.5	100	57.05	-3.280E-06	2.371E-03	5.683E-01
697	71	100	57.31	-3.280E-06	2.371E-03	5.683E-01
698	72	100	57.35	-3.280E-06	2.371E-03	5.683E-01
699	72	100	57.34	-3.280E-06	2.371E-03	5.683E-01
700	72	100	57.34	-2.967E-06	2.047E-03	8.641E-01
701	72	100	57.33	-2.653E-06	1.723E-03	1.160E+00
702	72	100	57.33	-2.340E-06	1.399E-03	1.456E+00
703	72	100	57.33	-2.340E-06	1.399E-03	1.456E+00
704	72	100	57.32	-2.340E-06	1.399E-03	1.456E+00
705	72	100	57.31	-2.340E-06	1.399E-03	1.456E+00
706	72	100	57.3	-2.340E-06	1.399E-03	1.456E+00
707	72.5	100	57.39	-2.340E-06	1.399E-03	1.456E+00
708	73	100	57.71	-2.340E-06	1.399E-03	1.456E+00
709	73.5	100	58.14	-2.340E-06	1.399E-03	1.456E+00
710	74	100	58.34	-2.340E-06	1.399E-03	1.456E+00
711	74	100	58.34	-2.340E-06	1.399E-03	1.456E+00
712	74.5	100	58.33	-2.340E-06	1.399E-03	1.456E+00
713	75	100	58.33	-2.340E-06	1.399E-03	1.456E+00
714	75	100	58.32	-2.340E-06	1.399E-03	1.456E+00
715	75	100	58.31	-2.340E-06	1.399E-03	1.456E+00
716	75	100	58.3	-2.340E-06	1.399E-03	1.456E+00
717	75	100	58.3	-2.340E-06	1.399E-03	1.456E+00
718	75	100	58.3	-2.340E-06	1.399E-03	1.456E+00

719	75	100	58.3	-2.340E-06	1.399E-03	1.456E+00
720	75	100	58.48	-2.340E-06	1.399E-03	1.456E+00
721	75	100	58.92	-2.340E-06	1.399E-03	1.456E+00
722	75	100	59.26	-2.340E-06	1.399E-03	1.456E+00
723	75	98	59.34	-2.340E-06	1.399E-03	1.456E+00
724	75	90	59.32	-2.340E-06	1.399E-03	1.456E+00
725	75	34	59.37	-3.622E-06	2.640E-03	9.220E-01
726	74	15	59.67	-4.905E-06	3.881E-03	3.883E-01
727	72	3	60.11	-6.187E-06	5.122E-03	-1.455E-01
728	70	(^e)	60.32	-6.187E-06	5.122E-03	-1.455E-01
729	69	(^e)	60.3	-6.187E-06	5.122E-03	-1.455E-01
730	68	(^e)	60.29	-6.187E-06	5.122E-03	-1.455E-01
731	70.5	53	60.27	-6.187E-06	5.122E-03	-1.455E-01
732	73	80	60.26	-6.187E-06	5.122E-03	-1.455E-01
733	75	88	60.25	-6.187E-06	5.122E-03	-1.455E-01
734	77	94	60.18	-6.187E-06	5.122E-03	-1.455E-01
735	79	97	59.83	-6.187E-06	5.122E-03	-1.455E-01
736	82	97	59.36	-6.187E-06	5.122E-03	-1.455E-01
737	85	98	59.65	-6.187E-06	5.122E-03	-1.455E-01
738	85	98	60.12	-6.187E-06	5.122E-03	-1.455E-01
739	87	97	59.8	-6.187E-06	5.122E-03	-1.455E-01
740	90	95	59.82	-6.187E-06	5.122E-03	-1.455E-01
741	92	90	60.18	-6.187E-06	5.122E-03	-1.455E-01
742	93	88	60.27	-6.187E-06	5.122E-03	-1.455E-01
743	94	86	60.31	-6.187E-06	5.122E-03	-1.455E-01
744	95	83	60.35	-6.187E-06	5.122E-03	-1.455E-01
745	96	79	60.37	-6.187E-06	5.122E-03	-1.455E-01
746	97	74	60.35	-6.187E-06	5.122E-03	-1.455E-01
747	98	68	60.33	-6.187E-06	5.122E-03	-1.455E-01
748	99	62	60.3	-6.187E-06	5.122E-03	-1.455E-01
749	100	54	60.26	-6.187E-06	5.122E-03	-1.455E-01
750	100	30	60.45	-7.791E-06	6.722E-03	-9.485E-01
751	100	22	61.12	-9.395E-06	8.322E-03	-1.752E+00
752	100	20	61.91	-1.100E-05	9.923E-03	-2.555E+00
753	100	22	62.23	-1.100E-05	9.923E-03	-2.555E+00
754	100	30	62.19	-1.100E-05	9.923E-03	-2.555E+00
755	100	65	62.17	-1.100E-05	9.923E-03	-2.555E+00
756	100	76	62.19	-1.100E-05	9.923E-03	-2.555E+00
757	100	80	62.24	-1.100E-05	9.923E-03	-2.555E+00
758	100	78	62.28	-1.100E-05	9.923E-03	-2.555E+00
759	100	72	62.3	-1.100E-05	9.923E-03	-2.555E+00
760	100	54	62.79	-1.100E-05	9.923E-03	-2.555E+00
761	95	30	63.22	-1.100E-05	9.923E-03	-2.555E+00
762	85	12	63.11	-1.100E-05	9.923E-03	-2.555E+00
763	68	(^e)	62.97	-1.100E-05	9.923E-03	-2.555E+00
764	57	(^e)	62.82	-1.100E-05	9.923E-03	-2.555E+00
765	56	(^e)	62.67	-1.100E-05	9.923E-03	-2.555E+00
766	57	(^e)	62.52	-1.100E-05	9.923E-03	-2.555E+00
767	57	(^e)	62.37	-1.100E-05	9.923E-03	-2.555E+00
768	57	22	62.32	-1.100E-05	9.923E-03	-2.555E+00
769	58	40	62.45	-1.100E-05	9.923E-03	-2.555E+00
770	59	45	62.64	-1.100E-05	9.923E-03	-2.555E+00
771	59	46	62.69	-1.100E-05	9.923E-03	-2.555E+00
772	59.5	45	62.66	-1.100E-05	9.923E-03	-2.555E+00
773	60	33	62.62	-1.100E-05	9.923E-03	-2.555E+00
774	60	0	62.59	-1.100E-05	9.923E-03	-2.555E+00
775	60	(^e)	62.55	-1.027E-05	9.176E-03	-2.095E+00
776	60	(^e)	62.51	-9.541E-06	8.429E-03	-1.636E+00
777	60	34	62.44	-8.813E-06	7.683E-03	-1.177E+00
778	60	50	62.37	-8.813E-06	7.683E-03	-1.177E+00
779	60	60	62.29	-8.813E-06	7.683E-03	-1.177E+00
780	60	69	62.21	-8.813E-06	7.683E-03	-1.177E+00
781	60	75	62.15	-8.813E-06	7.683E-03	-1.177E+00
782	60	79	62.46	-8.813E-06	7.683E-03	-1.177E+00
783	61	83	63.4	-8.813E-06	7.683E-03	-1.177E+00
784	61	84	63.97	-8.813E-06	7.683E-03	-1.177E+00

785	61	85	63.98	-8.813E-06	7.683E-03	-1.177E+00
786	62	85	63.94	-8.813E-06	7.683E-03	-1.177E+00
787	62	85	63.93	-8.813E-06	7.683E-03	-1.177E+00
788	62	85	63.92	-8.813E-06	7.683E-03	-1.177E+00
789	63	85	63.92	-8.813E-06	7.683E-03	-1.177E+00
790	63	85	63.91	-8.813E-06	7.683E-03	-1.177E+00
791	64	85	64.21	-8.813E-06	7.683E-03	-1.177E+00
792	64	85	64.61	-8.813E-06	7.683E-03	-1.177E+00
793	64	85	64.5	-8.813E-06	7.683E-03	-1.177E+00
794	64	85	64.05	-8.813E-06	7.683E-03	-1.177E+00
795	64	85	63.83	-8.813E-06	7.683E-03	-1.177E+00
796	64	84.5	63.81	-8.813E-06	7.683E-03	-1.177E+00
797	64	84	63.79	-8.813E-06	7.683E-03	-1.177E+00
798	64	83	63.77	-8.813E-06	7.683E-03	-1.177E+00
799	64	82	63.76	-8.813E-06	7.683E-03	-1.177E+00
800	64	81	63.75	-8.873E-06	7.725E-03	-1.104E+00
801	64	77	63.73	-8.933E-06	7.767E-03	-1.032E+00
802	64	72	63.72	-8.993E-06	7.810E-03	-9.592E-01
803	65	67	63.7	-8.993E-06	7.810E-03	-9.592E-01
804	66	64	63.69	-8.993E-06	7.810E-03	-9.592E-01
805	67	60	63.69	-8.993E-06	7.810E-03	-9.592E-01
806	69	62.3	63.68	-8.993E-06	7.810E-03	-9.592E-01
807	72	84	64.1	-8.993E-06	7.810E-03	-9.592E-01
808	73	90.5	64.6	-8.993E-06	7.810E-03	-9.592E-01
809	74	91	64.73	-8.993E-06	7.810E-03	-9.592E-01
810	74	90	64.73	-8.993E-06	7.810E-03	-9.592E-01
811	74	84.5	64.73	-8.993E-06	7.810E-03	-9.592E-01
812	73	74	64.72	-8.993E-06	7.810E-03	-9.592E-01
813	72	66	64.71	-8.993E-06	7.810E-03	-9.592E-01
814	71	60	64.71	-8.993E-06	7.810E-03	-9.592E-01
815	70	54	64.7	-8.993E-06	7.810E-03	-9.592E-01
816	69	50	64.69	-8.993E-06	7.810E-03	-9.592E-01
817	68	49	64.68	-8.993E-06	7.810E-03	-9.592E-01
818	68	48	64.82	-8.993E-06	7.810E-03	-9.592E-01
819	68	48	65.27	-8.993E-06	7.810E-03	-9.592E-01
820	68	48.5	65.65	-8.993E-06	7.810E-03	-9.592E-01
821	68	49	65.71	-8.993E-06	7.810E-03	-9.592E-01
822	68	51	65.72	-8.993E-06	7.810E-03	-9.592E-01
823	68	53.5	65.72	-8.993E-06	7.810E-03	-9.592E-01
824	68	55	65.72	-8.993E-06	7.810E-03	-9.592E-01
825	68	58	65.71	-8.993E-06	7.810E-03	-9.592E-01
826	68	60	65.7	-8.993E-06	7.810E-03	-9.592E-01
827	68	62	65.69	-8.993E-06	7.810E-03	-9.592E-01
828	68	64	65.67	-8.993E-06	7.810E-03	-9.592E-01
829	68	67	65.27	-8.993E-06	7.810E-03	-9.592E-01
830	69	68.5	64.33	-8.993E-06	7.810E-03	-9.592E-01
831	70	70	63.65	-8.993E-06	7.810E-03	-9.592E-01
832	70	70	63.5	-8.993E-06	7.810E-03	-9.592E-01
833	70	70	63.49	-8.993E-06	7.810E-03	-9.592E-01
834	70	70	63.49	-8.993E-06	7.810E-03	-9.592E-01
835	70	70	63.37	-8.993E-06	7.810E-03	-9.592E-01
836	70	70	63.01	-8.993E-06	7.810E-03	-9.592E-01
837	71	66	62.6	-8.993E-06	7.810E-03	-9.592E-01
838	73	64	62.44	-8.993E-06	7.810E-03	-9.592E-01
839	75	64	62.45	-8.993E-06	7.810E-03	-9.592E-01
840	77	98	62.47	-5.933E-06	4.759E-03	5.464E-01
841	79	100	62.5	-2.873E-06	1.709E-03	2.052E+00
842	81	100	62.52	1.865E-07	-1.342E-03	3.558E+00
843	82	100	62.54	1.865E-07	-1.342E-03	3.558E+00
844	83	100	62.57	1.865E-07	-1.342E-03	3.558E+00
845	84	98	62.7	1.865E-07	-1.342E-03	3.558E+00
846	84	94	62.9	1.865E-07	-1.342E-03	3.558E+00
847	85	93	63.11	1.865E-07	-1.342E-03	3.558E+00
848	86	94	63.32	1.865E-07	-1.342E-03	3.558E+00
849	87	98	63.53	1.865E-07	-1.342E-03	3.558E+00
850	89	100	63.74	1.865E-07	-1.342E-03	3.558E+00

851	92	100	62.2	1.865E-07	-1.342E-03	3.558E+00
852	95	100	62.67	1.865E-07	-1.342E-03	3.558E+00
853	97.5	100	63.19	1.865E-07	-1.342E-03	3.558E+00
854	100	100	63.62	1.865E-07	-1.342E-03	3.558E+00
855	100	100	64.06	1.865E-07	-1.342E-03	3.558E+00
856	100	100	64.19	6.218E-08	-4.474E-04	1.186E+00
857	100	100	63.87	-6.218E-08	4.474E-04	-1.186E+00
858	100	97	63.38	-1.865E-07	1.342E-03	-3.558E+00
859	96	(^a)	62.62	-1.865E-07	1.342E-03	-3.558E+00
860	94	(^a)	61.32	-1.865E-07	1.342E-03	-3.558E+00
861	91	(^a)	59.72	-1.865E-07	1.342E-03	-3.558E+00
862	88	(^a)	58.3	-1.865E-07	1.342E-03	-3.558E+00
863	86	(^a)	57.08	-1.865E-07	1.342E-03	-3.558E+00
864	84	(^a)	55.85	-1.865E-07	1.342E-03	-3.558E+00
865	82	(^a)	54.61	-1.865E-07	1.342E-03	-3.558E+00
866	79	(^a)	53.36	-1.865E-07	1.342E-03	-3.558E+00
867	77	(^a)	52.1	-1.865E-07	1.342E-03	-3.558E+00
868	75	(^a)	50.74	-1.865E-07	1.342E-03	-3.558E+00
869	73	(^a)	49.34	-1.865E-07	1.342E-03	-3.558E+00
870	72	(^a)	48.05	-1.865E-07	1.342E-03	-3.558E+00
871	72	(^a)	46.82	-1.865E-07	1.342E-03	-3.558E+00
872	72	(^a)	45.61	-1.865E-07	1.342E-03	-3.558E+00
873	71	8	44.37	-1.865E-07	1.342E-03	-3.558E+00
874	68	9	43.06	-1.865E-07	1.342E-03	-3.558E+00
875	64	(^a)	41.65	-1.865E-07	1.342E-03	-3.558E+00
876	58	(^a)	40.32	-1.865E-07	1.342E-03	-3.558E+00
877	56	53	39.28	-1.865E-07	1.342E-03	-3.558E+00
878	56	67	38.4	-1.865E-07	1.342E-03	-3.558E+00
879	56	70	37.3	-1.865E-07	1.342E-03	-3.558E+00
880	56	67	35.79	-1.865E-07	1.342E-03	-3.558E+00
881	55	60	34.14	-1.865E-07	1.342E-03	-3.558E+00
882	54	60	32.69	-1.865E-07	1.342E-03	-3.558E+00
883	49	75	31.38	-1.865E-07	1.342E-03	-3.558E+00
884	38	80	29.63	-1.865E-07	1.342E-03	-3.558E+00
885	30	78	27.22	-1.865E-07	1.342E-03	-3.558E+00
886	25	53	25.01	-1.865E-07	1.342E-03	-3.558E+00
887	18	32	23.09	-1.865E-07	1.342E-03	-3.558E+00
888	14	16	20.23	-1.865E-07	1.342E-03	-3.558E+00
889	9	3	17.2	-1.865E-07	1.342E-03	-3.558E+00
890	5	(^a)	12.61	-1.865E-07	1.342E-03	-3.558E+00
891	1	(^a)	7.43	-1.865E-07	1.342E-03	-3.558E+00
892	0	0	2.81	-1.865E-07	1.342E-03	-3.558E+00
893	0	0	0	-1.865E-07	1.342E-03	-3.558E+00
900	0	0	0	-1.865E-07	1.342E-03	-3.558E+00
901	0	0	0	8.801E-06	-7.855E-03	-7.493E-01
902	0	0	0	1.779E-05	-1.705E-02	2.059E+00
903	0	0	0	2.678E-05	-2.625E-02	4.867E+00
919	0	0	0	2.678E-05	-2.625E-02	4.867E+00
920	4.5	47	2.63	2.678E-05	-2.625E-02	4.867E+00
921	12	85	4.93	2.678E-05	-2.625E-02	4.867E+00
922	30	97	7.24	2.678E-05	-2.625E-02	4.867E+00
923	42	100	9.73	2.678E-05	-2.625E-02	4.867E+00
924	51	100	11.91	2.678E-05	-2.625E-02	4.867E+00
925	54	100	14.16	2.678E-05	-2.625E-02	4.867E+00
926	54	97	16.04	2.678E-05	-2.625E-02	4.867E+00
927	52	90	17.98	2.678E-05	-2.625E-02	4.867E+00
928	48	75	20.21	2.678E-05	-2.625E-02	4.867E+00
929	44	57	22.03	2.678E-05	-2.625E-02	4.867E+00
930	37	47	22.35	8.925E-06	-8.749E-03	1.622E+00
931	29	40	21.52	-8.925E-06	8.749E-03	-1.622E+00
932	24	34	20.04	-2.678E-05	2.625E-02	-4.867E+00
933	21	27	18.29	-2.678E-05	2.625E-02	-4.867E+00
934	22	24	16.4	-2.678E-05	2.625E-02	-4.867E+00
935	22.5	22	14.4	-2.678E-05	2.625E-02	-4.867E+00
936	20	16	12.23	-2.678E-05	2.625E-02	-4.867E+00
937	15	7	9.84	-2.678E-05	2.625E-02	-4.867E+00

938	10	0	8.55	-2.678E-05	2.625E-02	-4.867E+00
939	5	(^a)	7.56	-2.678E-05	2.625E-02	-4.867E+00
940	2	(^a)	6.14	-2.678E-05	2.625E-02	-4.867E+00
941	1	(^a)	2.6	-2.678E-05	2.625E-02	-4.867E+00
942	0	0	0	-2.678E-05	2.625E-02	-4.867E+00
943	0	0	0	-2.678E-05	2.625E-02	-4.867E+00
944	0	0	0	-1.658E-05	1.607E-02	-3.386E+00
945	1	0	1.06	-6.376E-06	5.889E-03	-1.905E+00
946	5	20	2.16	3.823E-06	-4.291E-03	-4.241E-01
947	15	43	3.3	3.823E-06	-4.291E-03	-4.241E-01
948	28	52	4.37	3.823E-06	-4.291E-03	-4.241E-01
949	34	64	5.42	3.823E-06	-4.291E-03	-4.241E-01
950	37	74	6.47	3.823E-06	-4.291E-03	-4.241E-01
951	37.5	90	7.51	3.823E-06	-4.291E-03	-4.241E-01
952	37	56	8.55	3.823E-06	-4.291E-03	-4.241E-01
953	36	27	9.55	3.823E-06	-4.291E-03	-4.241E-01
954	35	(^a)	10.25	3.823E-06	-4.291E-03	-4.241E-01
955	33	(^a)	10.78	3.823E-06	-4.291E-03	-4.241E-01
956	29	(^a)	11.16	3.823E-06	-4.291E-03	-4.241E-01
957	29	(^a)	11.76	3.823E-06	-4.291E-03	-4.241E-01
958	29	(^a)	12.59	3.823E-06	-4.291E-03	-4.241E-01
959	34	30	13.8	3.823E-06	-4.291E-03	-4.241E-01
960	38	75	14.85	3.823E-06	-4.291E-03	-4.241E-01
961	34	70	15.59	3.823E-06	-4.291E-03	-4.241E-01
962	31	25	16.2	3.823E-06	-4.291E-03	-4.241E-01
963	28	(^a)	16.82	3.823E-06	-4.291E-03	-4.241E-01
964	26	(^a)	17.55	3.823E-06	-4.291E-03	-4.241E-01
965	24	(^a)	17.91	3.823E-06	-4.291E-03	-4.241E-01
966	23	4	18.08	3.823E-06	-4.291E-03	-4.241E-01
967	23	22	18.1	3.823E-06	-4.291E-03	-4.241E-01
968	24	30	18.31	3.823E-06	-4.291E-03	-4.241E-01
969	23	32	18.67	3.823E-06	-4.291E-03	-4.241E-01
970	22	25	19.23	7.198E-06	-7.629E-03	2.015E+00
971	18	18	19.69	1.057E-05	-1.097E-02	4.453E+00
972	16	14	20.02	1.395E-05	-1.430E-02	6.892E+00
973	15	10	19.94	1.395E-05	-1.430E-02	6.892E+00
974	15	0	19.8	1.395E-05	-1.430E-02	6.892E+00
975	15	(^a)	19.69	1.395E-05	-1.430E-02	6.892E+00
976	15	(^a)	19.76	1.395E-05	-1.430E-02	6.892E+00
977	18	(^a)	19.93	1.395E-05	-1.430E-02	6.892E+00
978	25	40	20.24	1.395E-05	-1.430E-02	6.892E+00
979	37	90	20.69	1.395E-05	-1.430E-02	6.892E+00
980	46	90	21.23	1.395E-05	-1.430E-02	6.892E+00
981	49	90	21.78	1.395E-05	-1.430E-02	6.892E+00
982	49	90	22.15	1.395E-05	-1.430E-02	6.892E+00
983	49	85	22.33	1.395E-05	-1.430E-02	6.892E+00
984	47	77	22.36	1.395E-05	-1.430E-02	6.892E+00
985	44	59	22.36	4.650E-06	-4.768E-03	2.297E+00
986	43	36	22.33	-4.650E-06	4.768E-03	-2.297E+00
987	42	13	22.15	-1.395E-05	1.430E-02	-6.892E+00
988	40	(^a)	21.91	-1.395E-05	1.430E-02	-6.892E+00
989	41	65	21.62	-1.395E-05	1.430E-02	-6.892E+00
990	44	65	21.32	-1.395E-05	1.430E-02	-6.892E+00
991	45	65	21.01	-1.395E-05	1.430E-02	-6.892E+00
992	45	62	20.7	-1.395E-05	1.430E-02	-6.892E+00
993	44	56	20.48	-1.395E-05	1.430E-02	-6.892E+00
994	42	46	20.31	-1.395E-05	1.430E-02	-6.892E+00
995	41	36	20.13	-1.395E-05	1.430E-02	-6.892E+00
996	39	20	19.86	-1.395E-05	1.430E-02	-6.892E+00
997	38	4	19.49	-1.395E-05	1.430E-02	-6.892E+00
998	37	33	19.11	-1.395E-05	1.430E-02	-6.892E+00
999	38	39	18.71	-1.395E-05	1.430E-02	-6.892E+00
1,000	36	40	18.3	-1.395E-05	1.430E-02	-6.892E+00
1,001	35	40	17.86	-1.395E-05	1.430E-02	-6.892E+00
1,002	33	39	17.39	-1.395E-05	1.430E-02	-6.892E+00
1,003	30	36	16.86	-1.395E-05	1.430E-02	-6.892E+00

1,004	27	33	16.31	-1.395E-05	1.430E-02	-6.892E+00
1,005	22	24	15.75	-1.395E-05	1.430E-02	-6.892E+00
1,006	21	(^a)	15.24	-1.395E-05	1.430E-02	-6.892E+00
1,007	20	(^a)	14.73	-1.395E-05	1.430E-02	-6.892E+00
1,008	18	(^a)	14.23	-1.395E-05	1.430E-02	-6.892E+00
1,009	17	28	13.73	-1.395E-05	1.430E-02	-6.892E+00
1,010	16	5	12.79	-1.395E-05	1.430E-02	-6.892E+00
1,011	14	(^a)	11.11	-1.395E-05	1.430E-02	-6.892E+00
1,012	12	(^a)	9.43	-1.395E-05	1.430E-02	-6.892E+00
1,013	9	(^a)	7.75	-1.395E-05	1.430E-02	-6.892E+00
1,014	7	(^a)	6.07	-1.395E-05	1.430E-02	-6.892E+00
1,015	5	(^a)	4.39	-4.650E-06	4.768E-03	-2.297E+00
1,016	4	(^a)	2.71	4.650E-06	-4.768E-03	2.297E+00
1,017	3	(^a)	1.03	1.395E-05	-1.430E-02	6.892E+00
1,018	2	(^a)	0.19	1.395E-05	-1.430E-02	6.892E+00
1,019	0	0	0	1.395E-05	-1.430E-02	6.892E+00
1,020	0	0	0	1.395E-05	-1.430E-02	6.892E+00
1,021	0	0	0	1.458E-05	-1.532E-02	5.630E+00
1,022	0	0	0	1.520E-05	-1.634E-02	4.368E+00
1,023	0	0	0	1.583E-05	-1.736E-02	3.105E+00
1,024	0	0	0	1.583E-05	-1.736E-02	3.105E+00
1,025	2	7	3.25	1.583E-05	-1.736E-02	3.105E+00
1,026	6	15	5.47	1.583E-05	-1.736E-02	3.105E+00
1,027	10	28	6.71	1.583E-05	-1.736E-02	3.105E+00
1,028	11	26	6.71	1.583E-05	-1.736E-02	3.105E+00
1,029	10	10	6.71	5.277E-06	-5.787E-03	1.035E+00
1,030	8	3	6.55	-5.277E-06	5.787E-03	-1.035E+00
1,031	5	0	6.01	-1.583E-05	1.736E-02	-3.105E+00
1,032	2	0	5.15	-1.583E-05	1.736E-02	-3.105E+00
1,033	0	0	3.9	-1.583E-05	1.736E-02	-3.105E+00
1,034	0	0	2.19	-1.583E-05	1.736E-02	-3.105E+00
1,035	0	0	0	-5.277E-06	5.787E-03	-1.035E+00
1,036	0	0	0	5.277E-06	-5.787E-03	1.035E+00
1,037	0	0	0	1.583E-05	-1.736E-02	3.105E+00
1,060	0	0	0	1.583E-05	-1.736E-02	3.105E+00
1,061	4	5	1.95	1.583E-05	-1.736E-02	3.105E+00
1,062	11	35	3.7	1.583E-05	-1.736E-02	3.105E+00
1,063	21	73	5.53	1.583E-05	-1.736E-02	3.105E+00
1,064	25	86	7.22	1.583E-05	-1.736E-02	3.105E+00
1,065	26	90	8.64	1.583E-05	-1.736E-02	3.105E+00
1,066	25	90	10.33	1.583E-05	-1.736E-02	3.105E+00
1,067	23	83	11.18	5.277E-06	-5.787E-03	1.035E+00
1,068	20	32	10.57	-5.277E-06	5.787E-03	-1.035E+00
1,069	16	(^a)	9.33	-1.583E-05	1.736E-02	-3.105E+00
1,070	14	(^a)	7.87	-1.583E-05	1.736E-02	-3.105E+00
1,071	10	(^a)	6.27	-1.583E-05	1.736E-02	-3.105E+00
1,072	7	(^a)	4.58	-1.583E-05	1.736E-02	-3.105E+00
1,073	3	(^a)	3.81	-1.583E-05	1.736E-02	-3.105E+00
1,074	1	(^a)	2.35	-1.583E-05	1.736E-02	-3.105E+00
1,075	0	0	0	-1.583E-05	1.736E-02	-3.105E+00
1,076	0	0	0	-6.540E-06	7.597E-03	-2.563E+00
1,077	0	0	0	2.749E-06	-2.167E-03	-2.021E+00
1,078	0	0	0	1.204E-05	-1.193E-02	-1.480E+00
1,097	0	0	0	1.204E-05	-1.193E-02	-1.480E+00
1,098	1	3	1.35	1.204E-05	-1.193E-02	-1.480E+00
1,099	3	6	3.37	1.204E-05	-1.193E-02	-1.480E+00
1,100	6	13	6.4	1.204E-05	-1.193E-02	-1.480E+00
1,101	9	14	8.47	1.204E-05	-1.193E-02	-1.480E+00
1,102	12	16	9.57	1.204E-05	-1.193E-02	-1.480E+00
1,103	15	28	10.19	1.204E-05	-1.193E-02	-1.480E+00
1,104	18	60	10.35	1.204E-05	-1.193E-02	-1.480E+00
1,105	20	47	10.46	1.204E-05	-1.193E-02	-1.480E+00
1,106	21	31	10.11	1.204E-05	-1.193E-02	-1.480E+00
1,107	21	15	9.12	1.204E-05	-1.193E-02	-1.480E+00
1,108	20	(^a)	7.81	1.133E-05	-1.140E-02	1.667E-01
1,109	20	(^a)	7.87	1.062E-05	-1.087E-02	1.813E+00

1,110	20	(^a)	9.57	9.917E-06	-1.035E-02	3.459E+00
1,111	20	70	9.75	9.917E-06	-1.035E-02	3.459E+00
1,112	21	83	9.84	9.917E-06	-1.035E-02	3.459E+00
1,113	22	84	9.96	9.917E-06	-1.035E-02	3.459E+00
1,114	22	83	10.13	3.306E-06	-3.449E-03	1.153E+00
1,115	18	78	9.36	-3.306E-06	3.449E-03	-1.153E+00
1,116	14	68	8.8	-9.917E-06	1.035E-02	-3.459E+00
1,117	8	10	7.67	-9.917E-06	1.035E-02	-3.459E+00
1,118	4	4	6.08	-9.917E-06	1.035E-02	-3.459E+00
1,119	1	0	4.03	-9.917E-06	1.035E-02	-3.459E+00
1,120	0	0	0	-3.306E-06	3.449E-03	-1.153E+00
1,121	0	0	0	3.306E-06	-3.449E-03	1.153E+00
1,122	0	0	0	9.917E-06	-1.035E-02	3.459E+00
1,125	0	1	0	9.917E-06	-1.035E-02	3.459E+00
1,126	1	5	3.25	9.917E-06	-1.035E-02	3.459E+00
1,127	5	18	5.47	9.917E-06	-1.035E-02	3.459E+00
1,128	9	19	6.71	9.917E-06	-1.035E-02	3.459E+00
1,129	12	18	6.71	9.917E-06	-1.035E-02	3.459E+00
1,130	12	15	6.71	9.917E-06	-1.035E-02	3.459E+00
1,131	9	10	6.55	9.917E-06	-1.035E-02	3.459E+00
1,132	5	5	6.01	9.917E-06	-1.035E-02	3.459E+00
1,133	2	2	5.15	9.917E-06	-1.035E-02	3.459E+00
1,134	0	0	3.9	9.917E-06	-1.035E-02	3.459E+00
1,135	0	0	2.19	9.917E-06	-1.035E-02	3.459E+00
1,136	0	0	0	6.611E-06	-6.897E-03	2.306E+00
1,137	0	0	0	3.306E-06	-3.449E-03	1.153E+00
1,138	0	0	0	0	0	0
1,167	0	0	0	0	0	0

^aClosed throttle motoring.

(c) The following transient duty cycle applies for compression-ignition engines and powertrains:

Table 2 of Appendix B—Transient Duty Cycle for Compression-Ignition Engines and Powertrains

Record (seconds)	Engine testing		Vehicle speed (mi/hr)	Powertrain testing		
	Normalized revolutions per minute (percent)	Normalized torque (percent)		Road grade coefficients		
				<i>a</i>	<i>b</i>	<i>c</i>
1	0	0	0	0	0	0
2	0	0	0	1.248E-05	-1.073E-02	1.064E+00
3	0	0	0	1.872E-05	-1.609E-02	1.596E+00
24	0	0	0	1.872E-05	-1.609E-02	1.596E+00
25	0	3.67	0	1.872E-05	-1.609E-02	1.596E+00
26	0	47.69	0	1.872E-05	-1.609E-02	1.596E+00
27	2.78	59.41	0.33	1.872E-05	-1.609E-02	1.596E+00
28	8.12	84.54	1.67	1.872E-05	-1.609E-02	1.596E+00
29	13.95	80	2.83	1.872E-05	-1.609E-02	1.596E+00
30	29.9	80	4.02	1.872E-05	-1.609E-02	1.596E+00
31	33.87	79.29	5.64	1.872E-05	-1.609E-02	1.596E+00
32	27.86	38.25	7.39	1.872E-05	-1.609E-02	1.596E+00
33	19.63	26.67	8.83	1.872E-05	-1.609E-02	1.596E+00
34	26.79	15.1	9.15	1.872E-05	-1.609E-02	1.596E+00
35	19.85	16.47	9.7	1.872E-05	-1.609E-02	1.596E+00
36	17.51	28.05	11.37	1.872E-05	-1.609E-02	1.596E+00
37	17.86	20.38	13.04	1.872E-05	-1.609E-02	1.596E+00
38	16.37	(^a)	14.74	1.872E-05	-1.609E-02	1.596E+00
39	5.85	(^a)	16.41	2.033E-05	-1.775E-02	3.890E+00
40	14.13	(^a)	16.85	2.194E-05	-1.941E-02	6.184E+00
41	21.1	(^a)	16.09	2.356E-05	-2.107E-02	8.477E+00
42	15.63	(^a)	15.23	2.356E-05	-2.107E-02	8.477E+00
43	12.67	62.52	14.22	2.356E-05	-2.107E-02	8.477E+00
44	14.86	69.36	13.02	2.356E-05	-2.107E-02	8.477E+00
45	24.79	60	12.47	2.356E-05	-2.107E-02	8.477E+00
46	33.06	63.79	13.05	2.356E-05	-2.107E-02	8.477E+00
47	42.29	75.36	14.26	2.356E-05	-2.107E-02	8.477E+00
48	48.9	80	15.09	2.356E-05	-2.107E-02	8.477E+00
49	51.52	80	15.42	2.356E-05	-2.107E-02	8.477E+00
50	48.24	79.92	15.96	2.356E-05	-2.107E-02	8.477E+00
51	51.79	65.03	16.58	2.356E-05	-2.107E-02	8.477E+00
52	52.37	43.23	17.61	2.356E-05	-2.107E-02	8.477E+00
53	56.14	50	18.33	2.356E-05	-2.107E-02	8.477E+00
54	62.35	50	18.65	2.356E-05	-2.107E-02	8.477E+00
55	64.29	42.05	19.67	2.356E-05	-2.107E-02	8.477E+00
56	67.69	40	20.47	2.356E-05	-2.107E-02	8.477E+00
57	75.2	42.2	20.57	2.356E-05	-2.107E-02	8.477E+00
58	74.88	41.28	20.68	2.356E-05	-2.107E-02	8.477E+00
59	71.92	(^a)	21.56	2.356E-05	-2.107E-02	8.477E+00
60	71.88	(^a)	23.19	2.356E-05	-2.107E-02	8.477E+00
61	69.64	(^a)	23.64	7.852E-06	-7.024E-03	2.826E+00
62	71.24	(^a)	22.75	-7.852E-06	7.024E-03	-2.826E+00
63	71.72	30.54	21.81	-2.356E-05	2.107E-02	-8.477E+00
64	76.41	42.12	20.79	-2.356E-05	2.107E-02	-8.477E+00
65	73.02	50	19.86	-2.356E-05	2.107E-02	-8.477E+00
66	69.64	50	19.18	-2.356E-05	2.107E-02	-8.477E+00
67	72.09	43.16	18.75	-2.356E-05	2.107E-02	-8.477E+00
68	82.23	73.65	18.43	-2.356E-05	2.107E-02	-8.477E+00
69	78.58	(^a)	18.61	-2.356E-05	2.107E-02	-8.477E+00
70	75	(^a)	19.11	-2.356E-05	2.107E-02	-8.477E+00
71	75	(^a)	18.76	-2.356E-05	2.107E-02	-8.477E+00
72	72.47	(^a)	17.68	-2.356E-05	2.107E-02	-8.477E+00
73	62.91	(^a)	16.46	-2.356E-05	2.107E-02	-8.477E+00
74	58.93	13.57	15.06	-2.356E-05	2.107E-02	-8.477E+00
75	55.56	29.43	13.41	-2.356E-05	2.107E-02	-8.477E+00

76	57.14	20	11.91	-2.356E-05	2.107E-02	-8.477E+00
77	56.68	17.42	11.09	-2.356E-05	2.107E-02	-8.477E+00
78	53.88	10	10.9	-2.356E-05	2.107E-02	-8.477E+00
79	50.76	10	11.4	-2.356E-05	2.107E-02	-8.477E+00
80	50	(^e)	12.38	-2.356E-05	2.107E-02	-8.477E+00
81	46.83	(^e)	13.02	-2.356E-05	2.107E-02	-8.477E+00
82	35.63	10	12.3	-2.356E-05	2.107E-02	-8.477E+00
83	32.48	10	10.32	-2.356E-05	2.107E-02	-8.477E+00
84	26.79	10	9.7	-2.356E-05	2.107E-02	-8.477E+00
85	24.94	10	11.05	-2.356E-05	2.107E-02	-8.477E+00
86	23.21	16.74	11.88	-2.356E-05	2.107E-02	-8.477E+00
87	24.7	3.36	12.21	-2.356E-05	2.107E-02	-8.477E+00
88	25	(^e)	13.29	-2.356E-05	2.107E-02	-8.477E+00
89	24.47	(^e)	13.73	-2.356E-05	2.107E-02	-8.477E+00
90	18.71	(^e)	12.77	-2.356E-05	2.107E-02	-8.477E+00
91	10.85	(^e)	11.46	-2.356E-05	2.107E-02	-8.477E+00
92	3.4	(^e)	9.84	-2.356E-05	2.107E-02	-8.477E+00
93	0	0	7.62	-2.356E-05	2.107E-02	-8.477E+00
94	0	0	3.57	-2.356E-05	2.107E-02	-8.477E+00
95	0	0.91	1.33	-2.356E-05	2.107E-02	-8.477E+00
96	0	7.52	0	-2.356E-05	2.107E-02	-8.477E+00
97	0	0	0	-2.356E-05	2.107E-02	-8.477E+00
99	0	0	0	-2.356E-05	2.107E-02	-8.477E+00
100	0	0	0	-9.275E-06	8.450E-03	-4.643E+00
101	0	0	0	5.004E-06	-4.171E-03	-8.092E-01
102	0	0	0	1.928E-05	-1.679E-02	3.025E+00
128	0	0	0	1.928E-05	-1.679E-02	3.025E+00
129	1.58	(^e)	0	1.928E-05	-1.679E-02	3.025E+00
130	1.43	(^e)	0	1.928E-05	-1.679E-02	3.025E+00
131	0	0	0	1.928E-05	-1.679E-02	3.025E+00
132	0	0	0	1.928E-05	-1.679E-02	3.025E+00
133	1.91	9.28	0	1.928E-05	-1.679E-02	3.025E+00
134	2.75	0	0	1.928E-05	-1.679E-02	3.025E+00
135	0	0	0	1.928E-05	-1.679E-02	3.025E+00
146	0	0	0	1.928E-05	-1.679E-02	3.025E+00
147	0	5.51	0	1.928E-05	-1.679E-02	3.025E+00
148	0	11.34	0	1.928E-05	-1.679E-02	3.025E+00
149	0	0	0	1.928E-05	-1.679E-02	3.025E+00
157	0	0	0	1.928E-05	-1.679E-02	3.025E+00
158	0	0.21	0	1.928E-05	-1.679E-02	3.025E+00
159	0	30	0	1.928E-05	-1.679E-02	3.025E+00
160	0	26.78	0	1.928E-05	-1.679E-02	3.025E+00
161	0	20	0	1.928E-05	-1.679E-02	3.025E+00
162	0	20	0	1.928E-05	-1.679E-02	3.025E+00
163	0	4.12	0	1.928E-05	-1.679E-02	3.025E+00
164	0	0	0	1.928E-05	-1.679E-02	3.025E+00
183	0	0	0	1.928E-05	-1.679E-02	3.025E+00
184	0	20	0	1.928E-05	-1.679E-02	3.025E+00
185	0	20	0	1.928E-05	-1.679E-02	3.025E+00
186	0	11.73	0	1.928E-05	-1.679E-02	3.025E+00
187	0	0	0	1.928E-05	-1.679E-02	3.025E+00
213	0	0	0	1.928E-05	-1.679E-02	3.025E+00
214	0	73.41	0	1.928E-05	-1.679E-02	3.025E+00
215	0	90	0	1.928E-05	-1.679E-02	3.025E+00
216	27.95	81.3	0	1.928E-05	-1.679E-02	3.025E+00
217	36.74	90	2.8	1.928E-05	-1.679E-02	3.025E+00
218	39.29	90	5.59	1.928E-05	-1.679E-02	3.025E+00
219	41.44	90	8.39	1.928E-05	-1.679E-02	3.025E+00
220	45.57	82.41	11.19	1.928E-05	-1.679E-02	3.025E+00
221	59.52	80	14.3	1.928E-05	-1.679E-02	3.025E+00
222	66.99	90	16.03	1.928E-05	-1.679E-02	3.025E+00
223	80.22	90	17.3	1.928E-05	-1.679E-02	3.025E+00
224	86.41	93.88	19.72	1.928E-05	-1.679E-02	3.025E+00
225	86.53	50.94	23.18	1.928E-05	-1.679E-02	3.025E+00
226	84.46	17.02	25.27	1.928E-05	-1.679E-02	3.025E+00
227	88.54	28.6	26.91	1.928E-05	-1.679E-02	3.025E+00

228	89.29	39.83	28.89	1.928E-05	-1.679E-02	3.025E+00
229	89.29	30	29.43	1.928E-05	-1.679E-02	3.025E+00
230	89.29	26.69	29.5	1.928E-05	-1.679E-02	3.025E+00
231	90.16	20	30.49	1.928E-05	-1.679E-02	3.025E+00
232	89.92	20	32.02	1.928E-05	-1.679E-02	3.025E+00
233	89.29	36.06	32.91	1.928E-05	-1.679E-02	3.025E+00
234	85.86	40	32.55	1.928E-05	-1.679E-02	3.025E+00
235	85.51	30	32.26	1.928E-05	-1.679E-02	3.025E+00
236	84.42	32.75	32.65	1.928E-05	-1.679E-02	3.025E+00
237	86.48	35.68	33.5	1.928E-05	-1.679E-02	3.025E+00
238	88.55	30	34.96	1.928E-05	-1.679E-02	3.025E+00
239	89.29	44.93	36.44	1.928E-05	-1.679E-02	3.025E+00
240	90.9	50	36.95	6.428E-06	-5.597E-03	1.008E+00
241	77.27	(^e)	37.02	-6.428E-06	5.597E-03	-1.008E+00
242	56.75	(^e)	36.97	-1.928E-05	1.679E-02	-3.025E+00
243	50	(^e)	36.37	-1.928E-05	1.679E-02	-3.025E+00
244	41.07	(^e)	35.56	-1.928E-05	1.679E-02	-3.025E+00
245	37.38	45.18	34.72	-1.928E-05	1.679E-02	-3.025E+00
246	34.21	78.47	33.84	-1.928E-05	1.679E-02	-3.025E+00
247	32.13	80	33.4	-1.928E-05	1.679E-02	-3.025E+00
248	27.71	80	32.93	-1.928E-05	1.679E-02	-3.025E+00
249	22.64	80	31.98	-1.928E-05	1.679E-02	-3.025E+00
250	20.58	60.97	30.98	-1.928E-05	1.679E-02	-3.025E+00
251	16.25	27.34	29.91	-1.928E-05	1.679E-02	-3.025E+00
252	11.46	43.71	28.73	-1.928E-05	1.679E-02	-3.025E+00
253	9.02	68.95	27.34	-1.928E-05	1.679E-02	-3.025E+00
254	3.38	68.95	25.85	-1.928E-05	1.679E-02	-3.025E+00
255	1.32	44.28	24.49	-1.928E-05	1.679E-02	-3.025E+00
256	0	0	23.19	-1.928E-05	1.679E-02	-3.025E+00
257	0	0	21.87	-1.928E-05	1.679E-02	-3.025E+00
258	0	0	17.39	-1.928E-05	1.679E-02	-3.025E+00
259	0	0	12.92	-1.928E-05	1.679E-02	-3.025E+00
260	0	0	8.45	-1.928E-05	1.679E-02	-3.025E+00
261	0	0	3.97	-1.928E-05	1.679E-02	-3.025E+00
262	0	0	0	-1.928E-05	1.679E-02	-3.025E+00
263	0	24.97	0	-1.928E-05	1.679E-02	-3.025E+00
264	0	17.16	0	-1.928E-05	1.679E-02	-3.025E+00
265	0	6.2	0	-6.926E-06	5.240E-03	8.504E-01
266	0	10	0	5.431E-06	-6.313E-03	4.726E+00
267	0	10	0	1.779E-05	-1.787E-02	8.601E+00
268	0	0	0	1.779E-05	-1.787E-02	8.601E+00
320	0	0	0	1.779E-05	-1.787E-02	8.601E+00
321	0	15.55	0	1.779E-05	-1.787E-02	8.601E+00
322	0	20	0	1.779E-05	-1.787E-02	8.601E+00
323	21.59	19.08	1.2	1.779E-05	-1.787E-02	8.601E+00
324	20.54	10	2.18	1.779E-05	-1.787E-02	8.601E+00
325	10.32	1.86	2.88	1.779E-05	-1.787E-02	8.601E+00
326	6.13	(^e)	3	1.779E-05	-1.787E-02	8.601E+00
327	5.36	(^e)	2.28	1.779E-05	-1.787E-02	8.601E+00
328	0.64	(^e)	0	1.779E-05	-1.787E-02	8.601E+00
329	0	0	0	1.779E-05	-1.787E-02	8.601E+00
374	0	0	0	1.779E-05	-1.787E-02	8.601E+00
375	0	0	0	2.077E-05	-1.947E-02	7.751E+00
376	0	0	0	2.376E-05	-2.108E-02	6.900E+00
377	0	29.59	0	2.674E-05	-2.269E-02	6.050E+00
378	-1.34	87.46	0	2.674E-05	-2.269E-02	6.050E+00
379	7.93	100	1.15	2.674E-05	-2.269E-02	6.050E+00
380	41.11	100	3.82	2.674E-05	-2.269E-02	6.050E+00
381	68.65	100	6.11	2.674E-05	-2.269E-02	6.050E+00
382	71.43	100	10	2.674E-05	-2.269E-02	6.050E+00
383	73.34	94.64	14.52	2.674E-05	-2.269E-02	6.050E+00
384	76.24	83.07	18.09	2.674E-05	-2.269E-02	6.050E+00
385	78.3	88.51	20.64	2.674E-05	-2.269E-02	6.050E+00
386	82.14	79.83	22.36	2.674E-05	-2.269E-02	6.050E+00
387	82.14	61.66	23.7	2.674E-05	-2.269E-02	6.050E+00
388	84.45	66.77	24.8	2.674E-05	-2.269E-02	6.050E+00

389	91.86	60	25.26	2.674E-05	-2.269E-02	6.050E+00
390	94.64	72.76	25.44	2.674E-05	-2.269E-02	6.050E+00
391	97.48	8.43	25.57	2.674E-05	-2.269E-02	6.050E+00
392	99.92	(^a)	25.79	2.674E-05	-2.269E-02	6.050E+00
393	73.21	(^a)	25.8	2.674E-05	-2.269E-02	6.050E+00
394	70.83	(^a)	24.98	2.674E-05	-2.269E-02	6.050E+00
395	63.53	(^a)	23.7	2.674E-05	-2.269E-02	6.050E+00
396	61.46	(^a)	22.23	2.674E-05	-2.269E-02	6.050E+00
397	69.96	49.17	20.51	2.674E-05	-2.269E-02	6.050E+00
398	73.21	70	18.44	2.674E-05	-2.269E-02	6.050E+00
399	72.01	69.46	18.19	2.674E-05	-2.269E-02	6.050E+00
400	82.9	60	21.27	2.674E-05	-2.269E-02	6.050E+00
401	87.04	60	23.53	2.674E-05	-2.269E-02	6.050E+00
402	88.35	60	23.88	2.674E-05	-2.269E-02	6.050E+00
403	89.95	60	24.03	2.674E-05	-2.269E-02	6.050E+00
404	92.57	43.17	24.17	2.228E-05	-1.969E-02	5.457E+00
405	92.86	10.04	24.3	1.781E-05	-1.670E-02	4.864E+00
406	71.98	20	24.09	1.335E-05	-1.370E-02	4.271E+00
407	74.44	20	24.97	1.335E-05	-1.370E-02	4.271E+00
408	72.38	15.29	25.32	4.449E-06	-4.566E-03	1.424E+00
409	71.43	10	24.15	-4.449E-06	4.566E-03	-1.424E+00
410	68.63	(^a)	23.14	-1.335E-05	1.370E-02	-4.271E+00
411	66.17	(^a)	22.38	-1.335E-05	1.370E-02	-4.271E+00
412	63.93	(^a)	21.58	-1.335E-05	1.370E-02	-4.271E+00
413	63.02	(^a)	20.06	-1.335E-05	1.370E-02	-4.271E+00
414	69.64	(^a)	18.29	-1.335E-05	1.370E-02	-4.271E+00
415	71.69	1.45	16.16	-1.335E-05	1.370E-02	-4.271E+00
416	71.91	17.3	13.44	-1.335E-05	1.370E-02	-4.271E+00
417	69.85	11.13	11	-1.335E-05	1.370E-02	-4.271E+00
418	70.04	19.55	10.13	-7.827E-06	7.759E-03	-3.711E+00
419	75.32	24.16	11.5	-2.306E-06	1.819E-03	-3.150E+00
420	64.43	80	13.65	3.214E-06	-4.121E-03	-2.590E+00
421	70.63	74.83	15.03	3.214E-06	-4.121E-03	-2.590E+00
422	80.44	16.04	17.5	3.214E-06	-4.121E-03	-2.590E+00
423	66.11	(^a)	20.79	3.214E-06	-4.121E-03	-2.590E+00
424	60.73	(^a)	22.92	3.214E-06	-4.121E-03	-2.590E+00
425	61.19	(^a)	23.23	3.214E-06	-4.121E-03	-2.590E+00
426	53.03	(^a)	22.42	3.214E-06	-4.121E-03	-2.590E+00
427	56.73	(^a)	21.51	3.214E-06	-4.121E-03	-2.590E+00
428	62.5	2.38	20.46	3.214E-06	-4.121E-03	-2.590E+00
429	65.27	17.76	19.25	3.214E-06	-4.121E-03	-2.590E+00
430	64.4	(^a)	19.61	3.214E-06	-4.121E-03	-2.590E+00
431	60.06	(^a)	21.94	3.214E-06	-4.121E-03	-2.590E+00
432	32.17	(^a)	22.99	3.214E-06	-4.121E-03	-2.590E+00
433	18.53	(^a)	22.51	3.214E-06	-4.121E-03	-2.590E+00
434	10.26	(^a)	21.98	3.214E-06	-4.121E-03	-2.590E+00
435	-1.87	0	21.39	3.214E-06	-4.121E-03	-2.590E+00
436	-0.65	0	20.73	3.214E-06	-4.121E-03	-2.590E+00
437	7.65	60	20.38	3.214E-06	-4.121E-03	-2.590E+00
438	27.28	61.93	20.38	3.214E-06	-4.121E-03	-2.590E+00
439	59.91	63	20.78	3.214E-06	-4.121E-03	-2.590E+00
440	76.81	39.85	21.84	3.214E-06	-4.121E-03	-2.590E+00
441	79.76	30	23.6	3.214E-06	-4.121E-03	-2.590E+00
442	81.82	30	25.31	3.214E-06	-4.121E-03	-2.590E+00
443	87.39	10.4	26.41	3.214E-06	-4.121E-03	-2.590E+00
444	87.26	1.37	27.29	3.214E-06	-4.121E-03	-2.590E+00
445	85.71	10	27.97	3.214E-06	-4.121E-03	-2.590E+00
446	85.71	0.96	28.2	3.214E-06	-4.121E-03	-2.590E+00
447	85.71	(^a)	28.31	3.214E-06	-4.121E-03	-2.590E+00
448	76.13	28.34	29.22	3.214E-06	-4.121E-03	-2.590E+00
449	78.16	30.76	29.63	3.214E-06	-4.121E-03	-2.590E+00
450	76.93	29.18	29.64	3.214E-06	-4.121E-03	-2.590E+00
451	78.57	20	30.67	3.214E-06	-4.121E-03	-2.590E+00
452	77.87	20	32.17	3.214E-06	-4.121E-03	-2.590E+00
453	76.79	20	33.1	3.214E-06	-4.121E-03	-2.590E+00
454	78.05	20	33.3	3.214E-06	-4.121E-03	-2.590E+00

455	78.57	11.32	33.15	3.214E-06	-4.121E-03	-2.590E+00
456	69.5	(^a)	32.66	3.214E-06	-4.121E-03	-2.590E+00
457	64.29	(^a)	31.98	3.214E-06	-4.121E-03	-2.590E+00
458	63.68	(^a)	31.48	3.214E-06	-4.121E-03	-2.590E+00
459	62.5	0.04	31.39	3.214E-06	-4.121E-03	-2.590E+00
460	62.5	(^a)	31.3	3.214E-06	-4.121E-03	-2.590E+00
461	66.86	(^a)	32.2	3.214E-06	-4.121E-03	-2.590E+00
462	66.13	(^a)	33.13	3.214E-06	-4.121E-03	-2.590E+00
463	60.48	(^a)	33.13	3.214E-06	-4.121E-03	-2.590E+00
464	58.93	(^a)	33.14	3.214E-06	-4.121E-03	-2.590E+00
465	57.35	(^a)	33.14	3.214E-06	-4.121E-03	-2.590E+00
466	55.36	(^a)	33.15	3.214E-06	-4.121E-03	-2.590E+00
467	49.95	(^a)	33.16	3.214E-06	-4.121E-03	-2.590E+00
468	48.21	(^a)	33.16	3.214E-06	-4.121E-03	-2.590E+00
469	59.31	(^a)	33.17	2.308E-06	-3.167E-03	-2.524E+00
470	67.15	70	33.3	1.401E-06	-2.214E-03	-2.458E+00
471	76.79	54.53	33.56	4.942E-07	-1.260E-03	-2.391E+00
472	76.79	24.56	35.59	4.942E-07	-1.260E-03	-2.391E+00
473	79.29	(^a)	39.04	4.942E-07	-1.260E-03	-2.391E+00
474	80.36	(^a)	41.83	4.942E-07	-1.260E-03	-2.391E+00
475	94.18	(^a)	43.06	4.942E-07	-1.260E-03	-2.391E+00
476	66.07	(^a)	43.13	4.942E-07	-1.260E-03	-2.391E+00
477	65.48	(^a)	43.21	4.942E-07	-1.260E-03	-2.391E+00
478	63.41	10	43.29	4.942E-07	-1.260E-03	-2.391E+00
479	68.27	29.38	43.37	4.942E-07	-1.260E-03	-2.391E+00
480	72.87	40	44	4.942E-07	-1.260E-03	-2.391E+00
481	69.79	30.39	45.13	4.942E-07	-1.260E-03	-2.391E+00
482	66.19	26.46	47.02	4.942E-07	-1.260E-03	-2.391E+00
483	80.36	0	49.2	4.942E-07	-1.260E-03	-2.391E+00
484	81.13	0	49.92	4.942E-07	-1.260E-03	-2.391E+00
485	82.14	(^a)	50.36	4.942E-07	-1.260E-03	-2.391E+00
486	83.48	(^a)	51.52	4.942E-07	-1.260E-03	-2.391E+00
487	83.93	(^a)	52.11	4.942E-07	-1.260E-03	-2.391E+00
488	84.04	(^a)	52.12	4.942E-07	-1.260E-03	-2.391E+00
489	79.43	(^a)	52.14	4.942E-07	-1.260E-03	-2.391E+00
490	56.47	(^a)	52.16	4.942E-07	-1.260E-03	-2.391E+00
491	55.36	(^a)	52.18	4.942E-07	-1.260E-03	-2.391E+00
492	44.23	45.37	52.2	4.942E-07	-1.260E-03	-2.391E+00
493	46.87	86.99	52.22	4.942E-07	-1.260E-03	-2.391E+00
494	57.14	90	52.16	4.942E-07	-1.260E-03	-2.391E+00
495	58.03	90	52.53	4.942E-07	-1.260E-03	-2.391E+00
496	64.22	93.22	52.98	4.942E-07	-1.260E-03	-2.391E+00
497	70.42	95.21	53.65	4.942E-07	-1.260E-03	-2.391E+00
498	73.21	83.64	54.77	4.942E-07	-1.260E-03	-2.391E+00
499	77.46	80	55.14	4.942E-07	-1.260E-03	-2.391E+00
500	83.67	80	54.57	4.942E-07	-1.260E-03	-2.391E+00
501	84.71	80	53.63	4.942E-07	-1.260E-03	-2.391E+00
502	92.5	80	52.7	4.942E-07	-1.260E-03	-2.391E+00
503	90.38	41.89	52.03	4.942E-07	-1.260E-03	-2.391E+00
504	85.25	24.85	51.66	4.942E-07	-1.260E-03	-2.391E+00
505	87.5	50	51.42	4.942E-07	-1.260E-03	-2.391E+00
506	89.1	50	51.28	4.942E-07	-1.260E-03	-2.391E+00
507	94.83	46.82	51.13	4.942E-07	-1.260E-03	-2.391E+00
508	98.96	(^a)	51.53	4.942E-07	-1.260E-03	-2.391E+00
509	87.99	(^a)	52.04	1.647E-07	-4.200E-04	-7.972E-01
510	63.35	(^a)	51.32	-1.647E-07	4.200E-04	7.972E-01
511	60.06	(^a)	49.2	-4.942E-07	1.260E-03	2.391E+00
512	54.43	(^a)	46.43	-4.942E-07	1.260E-03	2.391E+00
513	42.88	(^a)	43.58	-4.942E-07	1.260E-03	2.391E+00
514	46.71	(^a)	40.65	-4.942E-07	1.260E-03	2.391E+00
515	48.21	(^a)	37.62	-4.942E-07	1.260E-03	2.391E+00
516	58.28	(^a)	34.62	-4.942E-07	1.260E-03	2.391E+00
517	69.64	(^a)	31.62	-4.942E-07	1.260E-03	2.391E+00
518	51.44	(^a)	28.44	-4.942E-07	1.260E-03	2.391E+00
519	38.02	(^a)	25.01	-4.942E-07	1.260E-03	2.391E+00
520	34.65	(^a)	21.38	-4.942E-07	1.260E-03	2.391E+00

521	19.97	(^a)	17.39	-4.942E-07	1.260E-03	2.391E+00
522	3.14	(^a)	12.76	-4.942E-07	1.260E-03	2.391E+00
523	0	0	6.14	-4.942E-07	1.260E-03	2.391E+00
524	-1.3	36.39	0	-4.942E-07	1.260E-03	2.391E+00
525	-0.21	5.75	0	-4.942E-07	1.260E-03	2.391E+00
526	0	0	0	-4.942E-07	1.260E-03	2.391E+00
527	0	0	0	-4.942E-07	1.260E-03	2.391E+00
528	0	0	0	-4.942E-07	1.260E-03	2.391E+00
529	0	0	0	-4.942E-07	1.260E-03	2.391E+00
530	0	0	0	7.439E-06	-5.768E-03	1.455E+00
531	0	0	0	1.537E-05	-1.280E-02	5.195E-01
532	0	0	0	2.331E-05	-1.982E-02	-4.165E-01
543	0	0	0	2.331E-05	-1.982E-02	-4.165E-01
544	0	(^a)	0	2.331E-05	-1.982E-02	-4.165E-01
545	0	0	0	2.331E-05	-1.982E-02	-4.165E-01
546	-0.67	0	0	2.331E-05	-1.982E-02	-4.165E-01
547	-0.5	0	0	2.331E-05	-1.982E-02	-4.165E-01
548	3.57	(^a)	0	2.331E-05	-1.982E-02	-4.165E-01
549	0.61	(^a)	0	2.331E-05	-1.982E-02	-4.165E-01
550	0	0	0	2.331E-05	-1.982E-02	-4.165E-01
551	0	0	0	2.331E-05	-1.982E-02	-4.165E-01
552	0	2.6	0	2.331E-05	-1.982E-02	-4.165E-01
553	0	20	0	2.331E-05	-1.982E-02	-4.165E-01
554	0	20	0	2.331E-05	-1.982E-02	-4.165E-01
555	0	7.96	0	2.331E-05	-1.982E-02	-4.165E-01
556	0	0	0	2.331E-05	-1.982E-02	-4.165E-01
557	0	0	0	2.331E-05	-1.982E-02	-4.165E-01
558	0	78.53	0	2.331E-05	-1.982E-02	-4.165E-01
559	1.65	60	0	2.331E-05	-1.982E-02	-4.165E-01
560	9.91	63.88	2.8	2.331E-05	-1.982E-02	-4.165E-01
561	14.29	70	6.02	2.331E-05	-1.982E-02	-4.165E-01
562	26.83	70	8.57	2.331E-05	-1.982E-02	-4.165E-01
563	38.29	70	11.07	2.331E-05	-1.982E-02	-4.165E-01
564	50.09	70	13.68	2.331E-05	-1.982E-02	-4.165E-01
565	56.6	66.52	16.52	2.331E-05	-1.982E-02	-4.165E-01
566	63.09	59.94	19.38	2.331E-05	-1.982E-02	-4.165E-01
567	65.16	80	21.91	2.331E-05	-1.982E-02	-4.165E-01
568	69.53	86.46	24.34	2.331E-05	-1.982E-02	-4.165E-01
569	78.6	90	27.02	2.331E-05	-1.982E-02	-4.165E-01
570	80.36	90	29.41	2.331E-05	-1.982E-02	-4.165E-01
571	82.35	100	31.57	2.331E-05	-1.982E-02	-4.165E-01
572	83.93	100	33.52	2.331E-05	-1.982E-02	-4.165E-01
573	84.7	100	35.75	2.331E-05	-1.982E-02	-4.165E-01
574	85.71	100	38.34	2.331E-05	-1.982E-02	-4.165E-01
575	87.04	100	40.83	2.331E-05	-1.982E-02	-4.165E-01
576	97.18	100	43.37	2.331E-05	-1.982E-02	-4.165E-01
577	98.21	83.92	44.9	2.331E-05	-1.982E-02	-4.165E-01
578	93.54	(^a)	45.32	7.769E-06	-6.608E-03	-1.388E-01
579	78.13	(^a)	45.25	-7.769E-06	6.608E-03	1.388E-01
580	80.36	0	44.24	-2.331E-05	1.982E-02	4.165E-01
581	81.59	(^a)	42.61	-2.331E-05	1.982E-02	4.165E-01
582	73.07	(^a)	40.93	-2.331E-05	1.982E-02	4.165E-01
583	58.92	(^a)	39.03	-2.331E-05	1.982E-02	4.165E-01
584	56.86	(^a)	36.96	-2.331E-05	1.982E-02	4.165E-01
585	54.22	(^a)	34.84	-2.331E-05	1.982E-02	4.165E-01
586	50.94	(^a)	32.66	-2.331E-05	1.982E-02	4.165E-01
587	47.74	(^a)	30.4	-2.331E-05	1.982E-02	4.165E-01
588	45.02	(^a)	28.04	-2.331E-05	1.982E-02	4.165E-01
589	39.56	(^a)	25.57	-2.331E-05	1.982E-02	4.165E-01
590	33.55	37.91	22.94	-2.331E-05	1.982E-02	4.165E-01
591	29.89	20	20.11	-2.331E-05	1.982E-02	4.165E-01
592	27.82	20	18.17	-2.331E-05	1.982E-02	4.165E-01
593	25.76	20	17.2	-2.331E-05	1.982E-02	4.165E-01
594	19.76	20	16.06	-2.331E-05	1.982E-02	4.165E-01
595	8.31	(^a)	14.93	-2.331E-05	1.982E-02	4.165E-01
596	0	0	13.78	-2.331E-05	1.982E-02	4.165E-01

597	0	0	10.72	-2.331E-05	1.982E-02	4.165E-01
598	0	0	6.24	-2.331E-05	1.982E-02	4.165E-01
599	0	0	1.77	-2.331E-05	1.982E-02	4.165E-01
600	0	0	0	-2.331E-05	1.982E-02	4.165E-01
605	0	0	0	-2.331E-05	1.982E-02	4.165E-01
606	2.25	6.3	0	-2.331E-05	1.982E-02	4.165E-01
607	9.2	17.87	0	-1.029E-05	8.762E-03	1.296E+00
608	12.4	20	0.75	2.727E-06	-2.302E-03	2.176E+00
609	18.04	20	1.9	1.574E-05	-1.337E-02	3.055E+00
610	21.49	22.59	3.81	1.574E-05	-1.337E-02	3.055E+00
611	29.76	17.5	5.91	1.574E-05	-1.337E-02	3.055E+00
612	35.98	(^a)	7.92	1.574E-05	-1.337E-02	3.055E+00
613	42.72	(^a)	9.86	1.574E-05	-1.337E-02	3.055E+00
614	58.93	7.78	9.37	1.574E-05	-1.337E-02	3.055E+00
615	60.71	10.93	5.32	1.574E-05	-1.337E-02	3.055E+00
616	60.35	32.04	1.45	1.574E-05	-1.337E-02	3.055E+00
617	58.93	40	4.28	1.574E-05	-1.337E-02	3.055E+00
618	59.86	40	6.78	1.574E-05	-1.337E-02	3.055E+00
619	60.71	40	9.12	1.574E-05	-1.337E-02	3.055E+00
620	60.71	48.33	11.69	1.574E-05	-1.337E-02	3.055E+00
621	67.79	99.53	14.17	1.574E-05	-1.337E-02	3.055E+00
622	69.64	100	16.35	1.574E-05	-1.337E-02	3.055E+00
623	69.64	100	19.18	1.574E-05	-1.337E-02	3.055E+00
624	68.81	100	22.35	1.574E-05	-1.337E-02	3.055E+00
625	67.86	100	25.17	1.574E-05	-1.337E-02	3.055E+00
626	67.86	100	27.6	1.574E-05	-1.337E-02	3.055E+00
627	67.86	100	29.72	1.574E-05	-1.337E-02	3.055E+00
628	67.53	100	31.71	1.574E-05	-1.337E-02	3.055E+00
629	65.18	97.5	33.6	1.574E-05	-1.337E-02	3.055E+00
630	68.58	90	35.39	1.574E-05	-1.337E-02	3.055E+00
631	71.66	90	37.08	1.574E-05	-1.337E-02	3.055E+00
632	74.5	90	38.83	1.574E-05	-1.337E-02	3.055E+00
633	75	98.79	40.28	1.574E-05	-1.337E-02	3.055E+00
634	75	100	41.29	1.574E-05	-1.337E-02	3.055E+00
635	74.65	100	42.31	1.574E-05	-1.337E-02	3.055E+00
636	73.21	100	42.9	1.574E-05	-1.337E-02	3.055E+00
637	74.13	94.91	42.94	1.574E-05	-1.337E-02	3.055E+00
638	77.38	90	42.83	1.574E-05	-1.337E-02	3.055E+00
639	80.04	90	42.74	1.574E-05	-1.337E-02	3.055E+00
640	80.36	99.81	42.65	1.574E-05	-1.337E-02	3.055E+00
641	79.87	100	42.56	1.574E-05	-1.337E-02	3.055E+00
642	76.79	100	42.88	1.574E-05	-1.337E-02	3.055E+00
643	76.79	95.47	43.29	1.574E-05	-1.337E-02	3.055E+00
644	77.88	90	43.3	1.574E-05	-1.337E-02	3.055E+00
645	78.57	90	43.37	1.574E-05	-1.337E-02	3.055E+00
646	78.57	80.74	43.79	1.574E-05	-1.337E-02	3.055E+00
647	78.57	79.17	44.07	1.574E-05	-1.337E-02	3.055E+00
648	78.57	77.21	44.01	1.574E-05	-1.337E-02	3.055E+00
649	78.57	100	44.41	1.046E-05	-8.994E-03	2.433E+00
650	78.57	94.45	44.85	5.183E-06	-4.623E-03	1.811E+00
651	78.57	90	44.83	-9.733E-08	-2.513E-04	1.190E+00
652	78.57	90	44.78	-9.733E-08	-2.513E-04	1.190E+00
653	80.36	90	45	-9.733E-08	-2.513E-04	1.190E+00
654	80.03	90	45.8	-9.733E-08	-2.513E-04	1.190E+00
655	79.18	90	46.46	-9.733E-08	-2.513E-04	1.190E+00
656	80.36	90	46.54	-9.733E-08	-2.513E-04	1.190E+00
657	80.36	90	46.12	-9.733E-08	-2.513E-04	1.190E+00
658	81.81	81.86	45.94	-9.733E-08	-2.513E-04	1.190E+00
659	82.14	80	45.81	-9.733E-08	-2.513E-04	1.190E+00
660	80.36	81.29	45.45	-9.733E-08	-2.513E-04	1.190E+00
661	79.85	92.86	45.81	-9.733E-08	-2.513E-04	1.190E+00
662	77.78	100	46.26	-9.733E-08	-2.513E-04	1.190E+00
663	76.79	100	46.32	-9.733E-08	-2.513E-04	1.190E+00
664	76.79	100	46.28	-9.733E-08	-2.513E-04	1.190E+00
665	80.05	100	46.46	-9.733E-08	-2.513E-04	1.190E+00
666	80.36	99.27	46.92	-9.733E-08	-2.513E-04	1.190E+00

667	80.77	90	47.16	-9.733E-08	-2.513E-04	1.190E+00
668	82.84	90	47.58	-9.733E-08	-2.513E-04	1.190E+00
669	84.9	90	48.04	-9.733E-08	-2.513E-04	1.190E+00
670	89.48	82.97	48.05	-9.733E-08	-2.513E-04	1.190E+00
671	91.07	80	48.02	-9.733E-08	-2.513E-04	1.190E+00
672	91.07	70.18	48	-9.733E-08	-2.513E-04	1.190E+00
673	91.07	80	47.97	-9.733E-08	-2.513E-04	1.190E+00
674	86.91	50.07	47.95	-9.733E-08	-2.513E-04	1.190E+00
675	77.7	(^a)	47.95	-9.733E-08	-2.513E-04	1.190E+00
676	76.79	(^a)	48.86	-9.733E-08	-2.513E-04	1.190E+00
677	65.29	22.19	49.92	-9.733E-08	-2.513E-04	1.190E+00
678	67.65	39.62	50.26	-9.733E-08	-2.513E-04	1.190E+00
679	67.64	48.8	50.18	-9.733E-08	-2.513E-04	1.190E+00
680	67.06	37.23	49.91	-9.733E-08	-2.513E-04	1.190E+00
681	69.64	34.34	49.9	-9.733E-08	-2.513E-04	1.190E+00
682	71.76	40	49.88	-9.733E-08	-2.513E-04	1.190E+00
683	69.21	47.49	49.87	-9.733E-08	-2.513E-04	1.190E+00
684	72.71	50	49.86	-9.733E-08	-2.513E-04	1.190E+00
685	73.33	39.36	49.85	-9.733E-08	-2.513E-04	1.190E+00
686	75	27.79	49.83	-9.733E-08	-2.513E-04	1.190E+00
687	75	16.21	49.82	-9.733E-08	-2.513E-04	1.190E+00
688	75	15.36	49.67	-9.733E-08	-2.513E-04	1.190E+00
689	76.24	26.93	49.6	-9.733E-08	-2.513E-04	1.190E+00
690	76.79	30	50.23	-9.733E-08	-2.513E-04	1.190E+00
691	76.79	30.08	50.78	-9.733E-08	-2.513E-04	1.190E+00
692	76.49	40	50.77	-9.733E-08	-2.513E-04	1.190E+00
693	75.58	40	50.76	-9.733E-08	-2.513E-04	1.190E+00
694	76.79	35.2	50.64	-9.733E-08	-2.513E-04	1.190E+00
695	77.93	30	50.14	-9.733E-08	-2.513E-04	1.190E+00
696	78.57	22.05	49.74	-9.733E-08	-2.513E-04	1.190E+00
697	76.87	(^a)	50.07	-9.733E-08	-2.513E-04	1.190E+00
698	74.8	(^a)	50.56	-9.733E-08	-2.513E-04	1.190E+00
699	72.74	(^a)	50.73	-2.744E-06	1.973E-03	3.071E-01
700	72.95	(^a)	50.76	-5.391E-06	4.198E-03	-5.755E-01
701	76.04	(^a)	50.79	-8.038E-06	6.423E-03	-1.458E+00
702	75.46	(^a)	50.82	-8.038E-06	6.423E-03	-1.458E+00
703	73.4	(^a)	50.85	-8.038E-06	6.423E-03	-1.458E+00
704	71.33	(^a)	50.88	-8.038E-06	6.423E-03	-1.458E+00
705	69.27	(^a)	50.91	-8.038E-06	6.423E-03	-1.458E+00
706	67.86	6.31	50.94	-8.038E-06	6.423E-03	-1.458E+00
707	70.68	0	50.98	-8.038E-06	6.423E-03	-1.458E+00
708	67.11	27.36	51	-8.038E-06	6.423E-03	-1.458E+00
709	64.29	40	51.03	-8.038E-06	6.423E-03	-1.458E+00
710	64.29	40	51.04	-8.038E-06	6.423E-03	-1.458E+00
711	66.07	38.44	51.05	-8.038E-06	6.423E-03	-1.458E+00
712	66.07	30	51.19	-8.038E-06	6.423E-03	-1.458E+00
713	66.07	30	51.69	-8.038E-06	6.423E-03	-1.458E+00
714	66.07	36.28	52.35	-8.038E-06	6.423E-03	-1.458E+00
715	64.67	47.86	52.85	-8.038E-06	6.423E-03	-1.458E+00
716	60.92	59.43	53.06	-8.038E-06	6.423E-03	-1.458E+00
717	65.89	50	53.07	-8.038E-06	6.423E-03	-1.458E+00
718	64.75	50	53.06	-8.038E-06	6.423E-03	-1.458E+00
719	66.07	45.85	53.06	-8.038E-06	6.423E-03	-1.458E+00
720	65.04	57.18	53.05	-8.038E-06	6.423E-03	-1.458E+00
721	68.2	62.7	53.05	-8.038E-06	6.423E-03	-1.458E+00
722	72.81	60	53.05	-8.038E-06	6.423E-03	-1.458E+00
723	71.59	60	53.04	-8.038E-06	6.423E-03	-1.458E+00
724	74.64	60	53.03	-6.308E-06	4.994E-03	-7.637E-01
725	74.5	56.4	53.02	-4.577E-06	3.565E-03	-6.931E-02
726	76.79	50	53.24	-2.847E-06	2.136E-03	6.251E-01
727	77.99	50	53.73	-2.847E-06	2.136E-03	6.251E-01
728	77.09	50	53.98	-2.847E-06	2.136E-03	6.251E-01
729	76.79	40.11	53.98	-2.847E-06	2.136E-03	6.251E-01
730	78.83	61.47	53.98	-2.847E-06	2.136E-03	6.251E-01
731	79.27	63.92	53.98	-2.847E-06	2.136E-03	6.251E-01
732	77.61	50	53.97	-2.847E-06	2.136E-03	6.251E-01

733	77.46	50	53.95	-2.847E-06	2.136E-03	6.251E-01
734	78.17	42.24	53.95	-2.847E-06	2.136E-03	6.251E-01
735	78.57	49.34	53.94	-2.847E-06	2.136E-03	6.251E-01
736	76.79	50.91	53.94	-2.847E-06	2.136E-03	6.251E-01
737	76.79	67.45	53.94	-2.847E-06	2.136E-03	6.251E-01
738	76.79	81.88	54.15	-2.847E-06	2.136E-03	6.251E-01
739	77.79	70	54.65	-2.847E-06	2.136E-03	6.251E-01
740	79.86	77.21	54.92	-2.847E-06	2.136E-03	6.251E-01
741	81.93	88.78	54.9	-2.847E-06	2.136E-03	6.251E-01
742	80.42	89.65	54.89	-2.847E-06	2.136E-03	6.251E-01
743	82.14	80	54.97	-2.847E-06	2.136E-03	6.251E-01
744	82.77	80	55.44	-2.847E-06	2.136E-03	6.251E-01
745	83.93	80	55.82	-2.847E-06	2.136E-03	6.251E-01
746	83.93	80	55.8	-2.847E-06	2.136E-03	6.251E-01
747	83.93	80	55.79	-2.847E-06	2.136E-03	6.251E-01
748	83.93	80	55.78	-2.847E-06	2.136E-03	6.251E-01
749	83.93	81.37	55.76	-5.174E-06	4.059E-03	-2.026E-01
750	84.46	87.05	55.75	-7.501E-06	5.983E-03	-1.030E+00
751	85.71	57.4	55.74	-9.827E-06	7.906E-03	-1.858E+00
752	85.71	42.19	55.42	-9.827E-06	7.906E-03	-1.858E+00
753	85.71	42.33	54.91	-9.827E-06	7.906E-03	-1.858E+00
754	85.71	40	55.19	-9.827E-06	7.906E-03	-1.858E+00
755	85.71	38.37	55.64	-9.827E-06	7.906E-03	-1.858E+00
756	85.71	12.83	55.31	-9.827E-06	7.906E-03	-1.858E+00
757	85.71	(^a)	55.36	-9.827E-06	7.906E-03	-1.858E+00
758	85.71	(^a)	55.75	-9.827E-06	7.906E-03	-1.858E+00
759	85.71	(^a)	55.78	-9.827E-06	7.906E-03	-1.858E+00
760	87.27	7.37	55.81	-9.827E-06	7.906E-03	-1.858E+00
761	89.33	19.74	55.85	-9.827E-06	7.906E-03	-1.858E+00
762	91.07	11.83	55.86	-9.827E-06	7.906E-03	-1.858E+00
763	91.07	26.81	55.84	-9.827E-06	7.906E-03	-1.858E+00
764	91.96	49.96	55.81	-9.827E-06	7.906E-03	-1.858E+00
765	92.86	60	55.78	-9.827E-06	7.906E-03	-1.858E+00
766	91.4	60	55.74	-9.827E-06	7.906E-03	-1.858E+00
767	92.8	60	56.19	-9.827E-06	7.906E-03	-1.858E+00
768	92.86	40	57.13	-9.827E-06	7.906E-03	-1.858E+00
769	92.86	25.75	57.59	-9.827E-06	7.906E-03	-1.858E+00
770	92.07	(^a)	57.55	-9.827E-06	7.906E-03	-1.858E+00
771	90	(^a)	57.52	-9.827E-06	7.906E-03	-1.858E+00
772	89.29	(^a)	57.53	-9.827E-06	7.906E-03	-1.858E+00
773	90.92	44.88	57.58	-9.827E-06	7.906E-03	-1.858E+00
774	91.07	36.4	57.63	-1.014E-05	8.189E-03	-1.873E+00
775	91.07	(^a)	57.64	-1.045E-05	8.472E-03	-1.887E+00
776	91.07	(^a)	58.11	-1.077E-05	8.756E-03	-1.902E+00
777	90.1	(^a)	58.52	-1.077E-05	8.756E-03	-1.902E+00
778	90.54	(^a)	58.38	-1.077E-05	8.756E-03	-1.902E+00
779	89.54	(^a)	58.24	-1.077E-05	8.756E-03	-1.902E+00
780	87.47	(^a)	58.1	-1.077E-05	8.756E-03	-1.902E+00
781	85.71	(^a)	57.96	-1.077E-05	8.756E-03	-1.902E+00
782	85.71	10	57.81	-1.077E-05	8.756E-03	-1.902E+00
783	85.71	0.23	57.67	-1.077E-05	8.756E-03	-1.902E+00
784	85.71	(^a)	57.66	-1.077E-05	8.756E-03	-1.902E+00
785	85.71	(^a)	57.89	-1.077E-05	8.756E-03	-1.902E+00
786	84	(^a)	58.03	-1.077E-05	8.756E-03	-1.902E+00
787	69.64	(^a)	57.99	-1.077E-05	8.756E-03	-1.902E+00
788	69.15	(^a)	57.96	-1.077E-05	8.756E-03	-1.902E+00
789	63.99	28.96	57.93	-1.077E-05	8.756E-03	-1.902E+00
790	59.98	80	57.89	-1.077E-05	8.756E-03	-1.902E+00
791	59.38	87.48	57.85	-1.077E-05	8.756E-03	-1.902E+00
792	63.78	90	57.8	-1.077E-05	8.756E-03	-1.902E+00
793	66.19	90	57.72	-1.077E-05	8.756E-03	-1.902E+00
794	67.46	92.2	57.65	-1.077E-05	8.756E-03	-1.902E+00
795	66.74	100	57.57	-1.077E-05	8.756E-03	-1.902E+00
796	68.81	94.65	57.5	-1.077E-05	8.756E-03	-1.902E+00
797	70.88	83.08	57.8	-1.077E-05	8.756E-03	-1.902E+00
798	71.43	71.51	58.72	-1.077E-05	8.756E-03	-1.902E+00

799	71.44	69.93	59.25	-8.819E-06	7.137E-03	-1.079E+00
800	73.51	58.36	59.19	-6.873E-06	5.518E-03	-2.559E-01
801	75	50	59.16	-4.927E-06	3.899E-03	5.670E-01
802	75	59.58	59.15	-4.927E-06	3.899E-03	5.670E-01
803	75	76.36	59.15	-4.927E-06	3.899E-03	5.670E-01
804	75	80	59.14	-4.927E-06	3.899E-03	5.670E-01
805	75	70.49	59.14	-4.927E-06	3.899E-03	5.670E-01
806	73.21	80	59.62	-4.927E-06	3.899E-03	5.670E-01
807	72.74	82.66	59.93	-4.927E-06	3.899E-03	5.670E-01
808	71.43	90	59.42	-4.927E-06	3.899E-03	5.670E-01
809	69.36	90	59.07	-4.927E-06	3.899E-03	5.670E-01
810	66.54	75.24	59.05	-4.927E-06	3.899E-03	5.670E-01
811	69.27	78.96	59.03	-4.927E-06	3.899E-03	5.670E-01
812	73.12	80	59.02	-4.927E-06	3.899E-03	5.670E-01
813	71.8	80	59	-4.927E-06	3.899E-03	5.670E-01
814	73.21	83.68	58.99	-4.927E-06	3.899E-03	5.670E-01
815	74.15	79.5	58.97	-4.927E-06	3.899E-03	5.670E-01
816	75	70	58.96	-4.927E-06	3.899E-03	5.670E-01
817	75	61.6	58.95	-4.927E-06	3.899E-03	5.670E-01
818	75	50.03	58.94	-4.927E-06	3.899E-03	5.670E-01
819	76.79	60	58.93	-4.927E-06	3.899E-03	5.670E-01
820	76.79	60	58.93	-4.927E-06	3.899E-03	5.670E-01
821	76.79	69.39	59.38	-4.927E-06	3.899E-03	5.670E-01
822	79.03	73.73	59.87	-4.927E-06	3.899E-03	5.670E-01
823	78.96	70	59.91	-4.927E-06	3.899E-03	5.670E-01
824	78.57	70	59.9	-4.927E-06	3.899E-03	5.670E-01
825	83.93	70.99	59.89	-4.927E-06	3.899E-03	5.670E-01
826	84.38	80	59.88	-4.927E-06	3.899E-03	5.670E-01
827	84.97	80	59.88	-4.927E-06	3.899E-03	5.670E-01
828	84.95	80	59.87	-4.927E-06	3.899E-03	5.670E-01
829	84.41	80	59.86	-5.382E-06	4.139E-03	6.372E-01
830	83.93	80	59.85	-5.838E-06	4.378E-03	7.074E-01
831	83.93	77.89	59.84	-6.294E-06	4.618E-03	7.776E-01
832	83.93	31.99	60.25	-6.294E-06	4.618E-03	7.776E-01
833	83.93	43.57	60.73	-6.294E-06	4.618E-03	7.776E-01
834	83.93	60.28	60.8	-6.294E-06	4.618E-03	7.776E-01
835	83.93	63.29	60.81	-6.294E-06	4.618E-03	7.776E-01
836	83.93	76.57	60.81	-6.294E-06	4.618E-03	7.776E-01
837	83.93	89.86	60.81	-6.294E-06	4.618E-03	7.776E-01
838	84.19	90	60.8	-6.294E-06	4.618E-03	7.776E-01
839	87.32	87	60.79	-6.294E-06	4.618E-03	7.776E-01
840	91.88	80	60.78	-6.294E-06	4.618E-03	7.776E-01
841	92.86	73.85	60.77	-6.294E-06	4.618E-03	7.776E-01
842	92.86	62.28	60.34	-6.294E-06	4.618E-03	7.776E-01
843	92.86	69.29	59.34	-6.294E-06	4.618E-03	7.776E-01
844	94.64	70	58.76	-6.294E-06	4.618E-03	7.776E-01
845	94.64	62.7	58.76	-6.294E-06	4.618E-03	7.776E-01
846	94.64	40	58.75	-6.294E-06	4.618E-03	7.776E-01
847	93.64	40	58.75	-6.294E-06	4.618E-03	7.776E-01
848	92.86	32.85	58.57	-6.294E-06	4.618E-03	7.776E-01
849	92.86	30	58.08	-7.448E-06	5.557E-03	8.947E-02
850	92.86	0.3	57.77	-8.602E-06	6.495E-03	-5.987E-01
851	92.53	11.87	57.78	-9.756E-06	7.434E-03	-1.287E+00
852	89.84	13.12	57.8	-9.756E-06	7.434E-03	-1.287E+00
853	87.5	5.01	57.82	-9.756E-06	7.434E-03	-1.287E+00
854	86.32	10	57.84	-9.756E-06	7.434E-03	-1.287E+00
855	85.71	(^a)	57.86	-9.756E-06	7.434E-03	-1.287E+00
856	85.71	(^a)	57.88	-9.756E-06	7.434E-03	-1.287E+00
857	85.71	(^a)	57.99	-9.756E-06	7.434E-03	-1.287E+00
858	85.21	(^a)	58.19	-9.756E-06	7.434E-03	-1.287E+00
859	83.93	(^a)	58.39	-9.756E-06	7.434E-03	-1.287E+00
860	83.93	(^a)	58.59	-9.756E-06	7.434E-03	-1.287E+00
861	85.29	5.18	58.79	-9.756E-06	7.434E-03	-1.287E+00
862	87.35	(^a)	59	-9.756E-06	7.434E-03	-1.287E+00
863	87.5	(^a)	57.32	-9.756E-06	7.434E-03	-1.287E+00
864	87.5	(^a)	58.15	-9.756E-06	7.434E-03	-1.287E+00

865	86.8	(^a)	58.57	-9.756E-06	7.434E-03	-1.287E+00
866	85.71	6.35	58.99	-9.756E-06	7.434E-03	-1.287E+00
867	85.71	12.98	59.41	-3.252E-06	2.478E-03	-4.290E-01
868	85.71	10	59.38	3.252E-06	-2.478E-03	4.290E-01
869	85.65	10	58.9	9.756E-06	-7.434E-03	1.287E+00
870	82.14	10	58.42	9.756E-06	-7.434E-03	1.287E+00
871	82.14	10	57.46	9.756E-06	-7.434E-03	1.287E+00
872	83.02	14.89	55.85	9.756E-06	-7.434E-03	1.287E+00
873	83.93	13.54	54.38	9.756E-06	-7.434E-03	1.287E+00
874	81.06	42.12	53.19	9.756E-06	-7.434E-03	1.287E+00
875	78.64	40.4	52	9.756E-06	-7.434E-03	1.287E+00
876	76.99	30	50.8	9.756E-06	-7.434E-03	1.287E+00
877	78.57	32.75	49.59	9.756E-06	-7.434E-03	1.287E+00
878	77.8	44.32	48.39	9.756E-06	-7.434E-03	1.287E+00
879	75.73	50	47.07	9.756E-06	-7.434E-03	1.287E+00
880	73.67	50	45.71	9.756E-06	-7.434E-03	1.287E+00
881	73.21	50	44.46	9.756E-06	-7.434E-03	1.287E+00
882	73.32	40	43.27	9.756E-06	-7.434E-03	1.287E+00
883	74.22	35.64	42.1	9.756E-06	-7.434E-03	1.287E+00
884	71.43	20	40.89	9.756E-06	-7.434E-03	1.287E+00
885	75.23	51.95	39.61	9.756E-06	-7.434E-03	1.287E+00
886	77.34	66.21	38.22	9.756E-06	-7.434E-03	1.287E+00
887	75.28	60	36.96	9.756E-06	-7.434E-03	1.287E+00
888	73.21	9.96	36.06	9.756E-06	-7.434E-03	1.287E+00
889	70.85	1.61	35.23	9.756E-06	-7.434E-03	1.287E+00
890	67.29	19.56	34.02	9.756E-06	-7.434E-03	1.287E+00
891	65.22	40	32.37	9.756E-06	-7.434E-03	1.287E+00
892	63.15	8.35	30.81	9.756E-06	-7.434E-03	1.287E+00
893	61.09	(^a)	29.57	9.756E-06	-7.434E-03	1.287E+00
894	42.1	8.95	28.26	9.756E-06	-7.434E-03	1.287E+00
895	31.96	10	25.94	9.756E-06	-7.434E-03	1.287E+00
896	29.42	7.38	23.56	9.756E-06	-7.434E-03	1.287E+00
897	26.04	(^a)	22	9.756E-06	-7.434E-03	1.287E+00
898	14.71	(^a)	19.21	9.756E-06	-7.434E-03	1.287E+00
899	1.9	(^a)	16.51	9.756E-06	-7.434E-03	1.287E+00
900	0	0	12.12	9.756E-06	-7.434E-03	1.287E+00
901	0	0	7.07	9.756E-06	-7.434E-03	1.287E+00
902	0	0	2.6	9.756E-06	-7.434E-03	1.287E+00
903	0	0	0	9.756E-06	-7.434E-03	1.287E+00
904	0	0	0	1.390E-05	-1.206E-02	3.180E+00
905	0	0	0	1.805E-05	-1.669E-02	5.073E+00
906	0	0	0	2.219E-05	-2.131E-02	6.967E+00
926	0	0	0	2.219E-05	-2.131E-02	6.967E+00
927	0	3.67	0	2.219E-05	-2.131E-02	6.967E+00
928	0	47.69	0	2.219E-05	-2.131E-02	6.967E+00
929	2.78	59.41	0.33	2.219E-05	-2.131E-02	6.967E+00
930	8.12	84.54	1.67	2.219E-05	-2.131E-02	6.967E+00
931	13.95	80	2.83	2.219E-05	-2.131E-02	6.967E+00
932	29.9	80	4.02	2.219E-05	-2.131E-02	6.967E+00
933	33.87	79.29	5.64	2.219E-05	-2.131E-02	6.967E+00
934	27.86	38.25	7.39	2.219E-05	-2.131E-02	6.967E+00
935	19.63	26.67	8.83	2.219E-05	-2.131E-02	6.967E+00
936	26.79	15.1	9.15	2.219E-05	-2.131E-02	6.967E+00
937	19.85	16.47	9.7	2.219E-05	-2.131E-02	6.967E+00
938	17.51	28.05	11.37	2.219E-05	-2.131E-02	6.967E+00
939	17.86	20.38	13.04	2.219E-05	-2.131E-02	6.967E+00
940	16.37	(^a)	14.74	2.219E-05	-2.131E-02	6.967E+00
941	5.85	(^a)	16.41	2.219E-05	-2.131E-02	6.967E+00
942	14.13	(^a)	16.85	2.219E-05	-2.131E-02	6.967E+00
943	21.1	(^a)	16.09	2.219E-05	-2.131E-02	6.967E+00
944	15.63	(^a)	15.23	2.219E-05	-2.131E-02	6.967E+00
945	12.67	62.52	14.22	2.219E-05	-2.131E-02	6.967E+00
946	14.86	69.36	13.02	2.219E-05	-2.131E-02	6.967E+00
947	24.79	60	12.47	2.219E-05	-2.131E-02	6.967E+00
948	33.06	63.79	13.05	2.219E-05	-2.131E-02	6.967E+00
949	42.29	75.36	14.26	2.219E-05	-2.131E-02	6.967E+00

950	48.9	80	15.09	2.219E-05	-2.131E-02	6.967E+00
951	51.52	80	15.42	2.219E-05	-2.131E-02	6.967E+00
952	48.24	79.92	15.96	2.219E-05	-2.131E-02	6.967E+00
953	51.79	65.03	16.58	2.219E-05	-2.131E-02	6.967E+00
954	52.37	43.23	17.61	2.219E-05	-2.131E-02	6.967E+00
955	56.14	50	18.33	2.219E-05	-2.131E-02	6.967E+00
956	62.35	50	18.65	2.219E-05	-2.131E-02	6.967E+00
957	64.29	42.05	19.67	2.219E-05	-2.131E-02	6.967E+00
958	67.69	40	20.47	2.219E-05	-2.131E-02	6.967E+00
959	75.2	42.2	20.57	2.219E-05	-2.131E-02	6.967E+00
960	74.88	41.28	20.68	2.219E-05	-2.131E-02	6.967E+00
961	71.92	(^a)	21.56	2.219E-05	-2.131E-02	6.967E+00
962	71.88	(^a)	23.19	2.219E-05	-2.131E-02	6.967E+00
963	69.64	(^a)	23.64	7.398E-06	-7.105E-03	2.322E+00
964	71.24	(^a)	22.75	-7.398E-06	7.105E-03	-2.322E+00
965	71.72	30.54	21.81	-2.219E-05	2.131E-02	-6.967E+00
966	76.41	42.12	20.79	-2.219E-05	2.131E-02	-6.967E+00
967	73.02	50	19.86	-2.219E-05	2.131E-02	-6.967E+00
968	69.64	50	19.18	-2.219E-05	2.131E-02	-6.967E+00
969	72.09	43.16	18.75	-2.219E-05	2.131E-02	-6.967E+00
970	82.23	73.65	18.43	-2.219E-05	2.131E-02	-6.967E+00
971	78.58	(^a)	18.61	-2.219E-05	2.131E-02	-6.967E+00
972	75	(^a)	19.11	-2.219E-05	2.131E-02	-6.967E+00
973	75	(^a)	18.76	-2.219E-05	2.131E-02	-6.967E+00
974	72.47	(^a)	17.68	-2.219E-05	2.131E-02	-6.967E+00
975	62.91	(^a)	16.46	-2.219E-05	2.131E-02	-6.967E+00
976	58.93	13.57	15.06	-2.219E-05	2.131E-02	-6.967E+00
977	55.56	29.43	13.41	-2.219E-05	2.131E-02	-6.967E+00
978	57.14	20	11.91	-2.219E-05	2.131E-02	-6.967E+00
979	56.68	17.42	11.09	-2.219E-05	2.131E-02	-6.967E+00
980	53.88	10	10.9	-2.219E-05	2.131E-02	-6.967E+00
981	50.76	10	11.4	-2.219E-05	2.131E-02	-6.967E+00
982	50	(^a)	12.38	-2.219E-05	2.131E-02	-6.967E+00
983	46.83	(^a)	13.02	-2.219E-05	2.131E-02	-6.967E+00
984	35.63	10	12.3	-2.219E-05	2.131E-02	-6.967E+00
985	32.48	10	10.32	-2.219E-05	2.131E-02	-6.967E+00
986	26.79	10	9.7	-2.219E-05	2.131E-02	-6.967E+00
987	24.94	10	11.05	-2.219E-05	2.131E-02	-6.967E+00
988	23.21	16.74	11.88	-2.219E-05	2.131E-02	-6.967E+00
989	24.7	3.36	12.21	-2.219E-05	2.131E-02	-6.967E+00
990	25	(^a)	13.29	-2.219E-05	2.131E-02	-6.967E+00
991	24.47	(^a)	13.73	-2.219E-05	2.131E-02	-6.967E+00
992	18.71	(^a)	12.77	-2.219E-05	2.131E-02	-6.967E+00
993	10.85	(^a)	11.46	-2.219E-05	2.131E-02	-6.967E+00
994	3.4	(^a)	9.84	-2.219E-05	2.131E-02	-6.967E+00
995	0	0	7.62	-2.219E-05	2.131E-02	-6.967E+00
996	0	0	3.57	-2.219E-05	2.131E-02	-6.967E+00
997	0	0.91	1.33	-2.219E-05	2.131E-02	-6.967E+00
998	0	7.52	0	-2.219E-05	2.131E-02	-6.967E+00
999	0	0	0	-2.219E-05	2.131E-02	-6.967E+00
1,000	0	0	0	-4.577E-06	5.686E-03	-3.784E+00
1,001	0	0	0	1.304E-05	-9.944E-03	-6.018E-01
1,002	0	0	0	3.066E-05	-2.557E-02	2.581E+00
1,030	0	0	0	3.066E-05	-2.557E-02	2.581E+00
1,031	1.58	(^a)	0	3.066E-05	-2.557E-02	2.581E+00
1,032	1.43	(^a)	0	3.066E-05	-2.557E-02	2.581E+00
1,033	0	0	0	3.066E-05	-2.557E-02	2.581E+00
1,034	0	0	0	3.066E-05	-2.557E-02	2.581E+00
1,035	1.91	9.28	0	3.066E-05	-2.557E-02	2.581E+00
1,036	2.75	0	0	3.066E-05	-2.557E-02	2.581E+00
1,037	0	0	0	3.066E-05	-2.557E-02	2.581E+00
1,048	0	0	0	3.066E-05	-2.557E-02	2.581E+00
1,049	0	5.51	0	3.066E-05	-2.557E-02	2.581E+00
1,050	0	11.34	0	3.066E-05	-2.557E-02	2.581E+00
1,051	0	0	0	3.066E-05	-2.557E-02	2.581E+00
1,059	0	0	0	3.066E-05	-2.557E-02	2.581E+00

1,060	0	0.21	0	3.066E-05	-2.557E-02	2.581E+00
1,061	0	30	0	3.066E-05	-2.557E-02	2.581E+00
1,062	0	26.78	0	3.066E-05	-2.557E-02	2.581E+00
1,063	0	20	0	3.066E-05	-2.557E-02	2.581E+00
1,064	0	20	0	3.066E-05	-2.557E-02	2.581E+00
1,065	0	4.12	0	3.066E-05	-2.557E-02	2.581E+00
1,066	0	0	0	3.066E-05	-2.557E-02	2.581E+00
1,085	0	0	0	3.066E-05	-2.557E-02	2.581E+00
1,086	0	20	0	3.066E-05	-2.557E-02	2.581E+00
1,087	0	20	0	3.066E-05	-2.557E-02	2.581E+00
1,088	0	11.73	0	3.066E-05	-2.557E-02	2.581E+00
1,089	0	0	0	3.066E-05	-2.557E-02	2.581E+00
1,115	0	0	0	3.066E-05	-2.557E-02	2.581E+00
1,116	0	73.41	0	3.066E-05	-2.557E-02	2.581E+00
1,117	0	90	0	3.066E-05	-2.557E-02	2.581E+00
1,118	27.95	81.3	2.83	3.066E-05	-2.557E-02	2.581E+00
1,119	36.74	90	5.87	3.066E-05	-2.557E-02	2.581E+00
1,120	39.29	90	8.67	3.066E-05	-2.557E-02	2.581E+00
1,121	41.44	90	11.47	3.066E-05	-2.557E-02	2.581E+00
1,122	45.57	82.41	14.26	3.066E-05	-2.557E-02	2.581E+00
1,123	59.52	80	16.91	3.066E-05	-2.557E-02	2.581E+00
1,124	66.99	90	18.33	3.066E-05	-2.557E-02	2.581E+00
1,125	80.22	90	19.35	3.066E-05	-2.557E-02	2.581E+00
1,126	86.41	93.88	21.55	3.066E-05	-2.557E-02	2.581E+00
1,127	86.53	50.94	24.84	3.066E-05	-2.557E-02	2.581E+00
1,128	84.46	17.02	26.81	3.066E-05	-2.557E-02	2.581E+00
1,129	88.54	28.6	28.36	2.397E-05	-2.025E-02	2.539E+00
1,130	89.29	39.83	30.31	1.729E-05	-1.494E-02	2.498E+00
1,131	89.29	30	30.82	1.060E-05	-9.616E-03	2.457E+00
1,132	89.29	26.69	30.86	1.060E-05	-9.616E-03	2.457E+00
1,133	90.16	20	31.82	1.060E-05	-9.616E-03	2.457E+00
1,134	89.92	20	33.33	1.060E-05	-9.616E-03	2.457E+00
1,135	89.29	36.06	34.2	1.060E-05	-9.616E-03	2.457E+00
1,136	85.86	40	33.82	1.060E-05	-9.616E-03	2.457E+00
1,137	85.51	30	33.51	1.060E-05	-9.616E-03	2.457E+00
1,138	84.42	32.75	33.87	1.060E-05	-9.616E-03	2.457E+00
1,139	86.48	35.68	34.7	1.060E-05	-9.616E-03	2.457E+00
1,140	88.55	30	36.14	1.060E-05	-9.616E-03	2.457E+00
1,141	89.29	44.93	37.6	1.060E-05	-9.616E-03	2.457E+00
1,142	90.9	50	38.09	1.060E-05	-9.616E-03	2.457E+00
1,143	77.27	(*)	38.13	3.535E-06	-3.205E-03	8.188E-01
1,144	56.75	(*)	38.05	-3.535E-06	3.205E-03	-8.188E-01
1,145	50	(*)	37.47	-1.060E-05	9.616E-03	-2.457E+00
1,146	41.07	(*)	36.69	-1.060E-05	9.616E-03	-2.457E+00
1,147	37.38	45.18	35.89	-1.060E-05	9.616E-03	-2.457E+00
1,148	34.21	78.47	35.06	-1.060E-05	9.616E-03	-2.457E+00
1,149	32.13	80	34.63	-1.060E-05	9.616E-03	-2.457E+00
1,150	27.71	80	34.13	-1.060E-05	9.616E-03	-2.457E+00
1,151	22.64	80	33.15	-1.060E-05	9.616E-03	-2.457E+00
1,152	20.58	60.97	32.12	-1.060E-05	9.616E-03	-2.457E+00
1,153	16.25	27.34	31.02	-1.060E-05	9.616E-03	-2.457E+00
1,154	11.46	43.71	29.82	-1.060E-05	9.616E-03	-2.457E+00
1,155	9.02	68.95	28.41	-1.060E-05	9.616E-03	-2.457E+00
1,156	3.38	68.95	26.91	-1.060E-05	9.616E-03	-2.457E+00
1,157	1.32	44.28	25.53	-1.060E-05	9.616E-03	-2.457E+00
1,158	0	0	24.21	-1.060E-05	9.616E-03	-2.457E+00
1,159	0	0	22.88	-1.060E-05	9.616E-03	-2.457E+00
1,160	0	0	18.4	-1.060E-05	9.616E-03	-2.457E+00
1,161	0	0	13.93	-1.060E-05	9.616E-03	-2.457E+00
1,162	0	0	9.45	-1.060E-05	9.616E-03	-2.457E+00
1,163	0	0	4.98	-1.060E-05	9.616E-03	-2.457E+00
1,164	0	0	0.5	-7.069E-06	6.411E-03	-1.638E+00
1,165	0	24.97	0	-3.535E-06	3.205E-03	-8.188E-01
1,166	0	17.16	0	0	0	0
1,167	0	6.2	0	0	0	0
1,168	0	10	0	0	0	0

1,169	0	10	0	0	0	0
1,170	0	0	0	0	0	0
1,199	0	0	0	0	0	0

^aClosed throttle motoring.

(d) The following transient Low Load Cycle applies for compression-ignition engines and powertrains:

Table 3 of Appendix B—Low Load Cycle for Compression-Ignition Engines and Powertrains

Record (seconds)	Engine testing		Powertrain testing			
	Normalized revolutions per minute (percent)	Normalized torque (percent)	Vehicle speed (mi/hr)	Road grade coefficients		
				a	b	c
1	0	0	0	0	0	0
2	0	0	0	-4.441E-06	-1.101E-03	-8.083E-02
3	0	0	0	-6.661E-06	-1.651E-03	-1.213E-01
69	0	0	0	-6.661E-06	-1.651E-03	-1.213E-01
70	3	5	0	-6.661E-06	-1.651E-03	-1.213E-01
71	7	10	0	-6.661E-06	-1.651E-03	-1.213E-01
72	15.1	16.5	2.81	-6.661E-06	-1.651E-03	-1.213E-01
73	28.3	10.4	3.37	-6.661E-06	-1.651E-03	-1.213E-01
74	46	11.1	4.13	-6.661E-06	-1.651E-03	-1.213E-01
75	66.5	12.3	5.01	-6.661E-06	-1.651E-03	-1.213E-01
76	37.6	1	4.76	-6.661E-06	-1.651E-03	-1.213E-01
77	54.6	20.7	5.82	-6.661E-06	-1.651E-03	-1.213E-01
78	76.6	15.9	7.07	-6.661E-06	-1.651E-03	-1.213E-01
79	47.9	2	6.8	-6.661E-06	-1.651E-03	-1.213E-01
80	64.7	36.4	8.13	-6.661E-06	-1.651E-03	-1.213E-01
81	77.4	29.6	9.59	-6.661E-06	-1.651E-03	-1.213E-01
82	28.2	2.9	9.11	-6.661E-06	-1.651E-03	-1.213E-01
83	48.4	54.9	11.38	-6.661E-06	-1.651E-03	-1.213E-01
84	72.1	17.7	14.2	-6.661E-06	-1.651E-03	-1.213E-01
85	82.5	10.7	15.43	-6.661E-06	-1.651E-03	-1.213E-01
86	60.2	1.1	16.12	-6.661E-06	-1.651E-03	-1.213E-01
87	64.4	(^e)	16.88	-6.661E-06	-1.651E-03	-1.213E-01
88	67.8	(^e)	17.38	-6.661E-06	-1.651E-03	-1.213E-01
89	62.7	12	17.72	-6.661E-06	-1.651E-03	-1.213E-01
90	47	28.9	18.17	-6.661E-06	-1.651E-03	-1.213E-01
91	52.3	(^e)	19.23	-6.661E-06	-1.651E-03	-1.213E-01
92	54.5	(^e)	19.66	-6.661E-06	-1.651E-03	-1.213E-01
93	54.7	(^e)	19.7	-6.661E-06	-1.651E-03	-1.213E-01
94	53.6	(^e)	19.49	-6.661E-06	-1.651E-03	-1.213E-01
95	50.4	(^e)	18.89	-6.661E-06	-1.651E-03	-1.213E-01
96	46	(^e)	18.06	-6.661E-06	-1.651E-03	-1.213E-01
97	44.1	(^e)	17.69	-6.661E-06	-1.651E-03	-1.213E-01
98	42.5	(^e)	17.39	-6.661E-06	-1.651E-03	-1.213E-01
99	42.4	(^e)	17.38	-6.661E-06	-1.651E-03	-1.213E-01
100	43	(^e)	17.5	-6.661E-06	-1.651E-03	-1.213E-01
101	42.5	(^e)	17.39	-6.661E-06	-1.651E-03	-1.213E-01
102	41.4	(^e)	17.18	-6.661E-06	-1.651E-03	-1.213E-01
103	41.6	(^e)	17.21	-6.661E-06	-1.651E-03	-1.213E-01
104	42.1	(^e)	17.31	-2.220E-06	-5.503E-04	-4.042E-02
105	41.4	(^e)	17.18	2.220E-06	5.503E-04	4.042E-02
106	40.6	(^e)	17.06	6.661E-06	1.651E-03	1.213E-01
107	38.2	(^e)	16.57	6.661E-06	1.651E-03	1.213E-01
108	35.4	0.8	16.04	6.661E-06	1.651E-03	1.213E-01
109	34	2.8	15.78	6.661E-06	1.651E-03	1.213E-01
110	33	4.5	15.59	6.661E-06	1.651E-03	1.213E-01
111	32.3	5.3	15.45	6.661E-06	1.651E-03	1.213E-01
112	31.5	0	15.31	6.661E-06	1.651E-03	1.213E-01
113	28.9	(^e)	14.85	6.661E-06	1.651E-03	1.213E-01
114	28.8	(^e)	14.84	6.661E-06	1.651E-03	1.213E-01
115	24.9	(^e)	14.1	6.661E-06	1.651E-03	1.213E-01
116	19.1	(^e)	13.06	6.661E-06	1.651E-03	1.213E-01
117	29.8	(^e)	11.8	6.661E-06	1.651E-03	1.213E-01
118	20.6	(^e)	10.43	6.661E-06	1.651E-03	1.213E-01
119	14.7	(^e)	9.55	6.661E-06	1.651E-03	1.213E-01
120	19.7	16.8	9.1	6.661E-06	1.651E-03	1.213E-01
121	21.8	(^e)	8.39	6.661E-06	1.651E-03	1.213E-01
122	15.2	(^e)	7.62	6.661E-06	1.651E-03	1.213E-01

123	24.8	10.6	6.59	6.661E-06	1.651E-03	1.213E-01
124	20.5	9.5	5.05	6.661E-06	1.651E-03	1.213E-01
125	19.7	15.6	4.15	6.661E-06	1.651E-03	1.213E-01
126	8.5	(°)	3.29	6.661E-06	1.651E-03	1.213E-01
127	0	0	2.77	6.661E-06	1.651E-03	1.213E-01
128	0.5	5.4	2.69	6.661E-06	1.651E-03	1.213E-01
129	0	0	2.45	6.661E-06	1.651E-03	1.213E-01
130	0.5	5.7	2.08	6.661E-06	1.651E-03	1.213E-01
131	1.7	9.8	1.69	6.661E-06	1.651E-03	1.213E-01
132	6.7	14.6	1.64	2.220E-06	5.503E-04	4.042E-02
133	6.5	12	1.83	-2.220E-06	-5.503E-04	-4.042E-02
134	6.5	9.8	2.02	-6.661E-06	-1.651E-03	-1.213E-01
135	6.6	8.6	2.14	-6.661E-06	-1.651E-03	-1.213E-01
136	6	8.1	2.21	-6.661E-06	-1.651E-03	-1.213E-01
137	4.5	7.3	2.21	-6.661E-06	-1.651E-03	-1.213E-01
138	3.4	8.2	2.22	-6.661E-06	-1.651E-03	-1.213E-01
139	8	17	2.44	-6.661E-06	-1.651E-03	-1.213E-01
140	17.4	8	2.91	-6.661E-06	-1.651E-03	-1.213E-01
141	28.3	6.2	3.38	-6.661E-06	-1.651E-03	-1.213E-01
142	35.4	9.6	3.68	-6.661E-06	-1.651E-03	-1.213E-01
143	51	9.7	4.35	-6.661E-06	-1.651E-03	-1.213E-01
144	62	10.6	4.82	-6.661E-06	-1.651E-03	-1.213E-01
145	32.4	1	4.49	-6.661E-06	-1.651E-03	-1.213E-01
146	58.1	24.4	6.01	-6.661E-06	-1.651E-03	-1.213E-01
147	89.1	27.9	7.71	-6.661E-06	-1.651E-03	-1.213E-01
148	32.4	3	7.32	-6.661E-06	-1.651E-03	-1.213E-01
149	38.6	17.1	8.08	-6.661E-06	-1.651E-03	-1.213E-01
150	48.9	19.8	9.02	-6.661E-06	-1.651E-03	-1.213E-01
151	61.4	18.7	10.16	-6.661E-06	-1.651E-03	-1.213E-01
152	70.7	14.8	11.03	-6.661E-06	-1.651E-03	-1.213E-01
153	45.7	0.8	10.91	-6.661E-06	-1.651E-03	-1.213E-01
154	49	20.7	11.51	-6.661E-06	-1.651E-03	-1.213E-01
155	57.5	23.4	12.49	-6.661E-06	-1.651E-03	-1.213E-01
156	66.7	22.1	13.56	-6.661E-06	-1.651E-03	-1.213E-01
157	48.7	5.8	13.8	-6.661E-06	-1.651E-03	-1.213E-01
158	44.5	14.3	13.91	-6.661E-06	-1.651E-03	-1.213E-01
159	45	6.9	14	-6.661E-06	-1.651E-03	-1.213E-01
160	44.3	1.5	13.91	-6.661E-06	-1.651E-03	-1.213E-01
161	46.4	19.2	14.19	-6.661E-06	-1.651E-03	-1.213E-01
162	48.3	6.9	14.48	-2.220E-06	-5.503E-04	-4.042E-02
163	48.2	5.8	14.47	2.220E-06	5.503E-04	4.042E-02
164	47.6	5.8	14.38	6.661E-06	1.651E-03	1.213E-01
165	46.6	4	14.24	6.661E-06	1.651E-03	1.213E-01
166	45.1	3.6	14.02	6.661E-06	1.651E-03	1.213E-01
167	44	2.9	13.86	6.661E-06	1.651E-03	1.213E-01
168	42.4	3.4	13.63	6.661E-06	1.651E-03	1.213E-01
169	41.7	1	13.52	6.661E-06	1.651E-03	1.213E-01
170	37.9	(°)	12.97	6.661E-06	1.651E-03	1.213E-01
171	32.7	(°)	12.22	6.661E-06	1.651E-03	1.213E-01
172	20.8	(°)	10.49	6.661E-06	1.651E-03	1.213E-01
173	18.8	13.7	8	6.661E-06	1.651E-03	1.213E-01
174	16.3	3.5	5.87	6.661E-06	1.651E-03	1.213E-01
175	14.1	5.3	4.27	6.661E-06	1.651E-03	1.213E-01
176	6.7	1.3	2.95	6.661E-06	1.651E-03	1.213E-01
177	0.1	5.9	1.76	6.661E-06	1.651E-03	1.213E-01
178	0	0	0.96	2.220E-06	5.503E-04	4.042E-02
179	0	0	0	-2.220E-06	-5.503E-04	-4.042E-02
180	0	0	0	-6.661E-06	-1.651E-03	-1.213E-01
181	0	0	0	-6.661E-06	-1.651E-03	-1.213E-01
182	1.2	6.3	0	-6.661E-06	-1.651E-03	-1.213E-01
183	2	9.9	0.14	-6.661E-06	-1.651E-03	-1.213E-01
184	5.1	12	0.51	-6.661E-06	-1.651E-03	-1.213E-01
185	4.6	8.7	0.72	-6.661E-06	-1.651E-03	-1.213E-01
186	0	0	0.84	-6.661E-06	-1.651E-03	-1.213E-01
187	0	0	0.93	-6.661E-06	-1.651E-03	-1.213E-01
188	0	0	0.71	-6.661E-06	-1.651E-03	-1.213E-01

189	0	0	0	-6.661E-06	-1.651E-03	-1.213E-01
199	0	0	0	-6.661E-06	-1.651E-03	-1.213E-01
200	0	0	0	-7.610E-07	-4.944E-03	1.232E+00
201	0	0	0	5.139E-06	-8.238E-03	2.586E+00
202	0	0	0	1.104E-05	-1.153E-02	3.939E+00
206	0	0	0	1.104E-05	-1.153E-02	3.939E+00
207	1.1	9.2	0.02	1.104E-05	-1.153E-02	3.939E+00
208	5.9	22	0.55	1.104E-05	-1.153E-02	3.939E+00
209	6.7	24.1	1.47	1.104E-05	-1.153E-02	3.939E+00
210	7	18.6	2.39	1.104E-05	-1.153E-02	3.939E+00
211	14.8	11.2	2.79	1.104E-05	-1.153E-02	3.939E+00
212	24.9	10.8	3.23	1.104E-05	-1.153E-02	3.939E+00
213	37.7	8.2	3.78	1.104E-05	-1.153E-02	3.939E+00
214	50.4	7.7	4.33	1.104E-05	-1.153E-02	3.939E+00
215	62.3	8.3	4.84	1.104E-05	-1.153E-02	3.939E+00
216	30.7	4.7	4.37	1.104E-05	-1.153E-02	3.939E+00
217	34.2	19.4	4.69	1.104E-05	-1.153E-02	3.939E+00
218	52.4	12.2	5.72	1.104E-05	-1.153E-02	3.939E+00
219	63.4	7.7	6.35	3.680E-06	-3.844E-03	1.313E+00
220	46.8	0.5	6.78	-3.680E-06	3.844E-03	-1.313E+00
221	41.8	2.7	6.57	-1.104E-05	1.153E-02	-3.939E+00
222	38.8	3.8	6.35	-1.104E-05	1.153E-02	-3.939E+00
223	36.3	4.7	6.17	-1.104E-05	1.153E-02	-3.939E+00
224	36.1	3.5	6.16	-1.104E-05	1.153E-02	-3.939E+00
225	35.4	1.6	6.11	-1.104E-05	1.153E-02	-3.939E+00
226	34.9	(°)	6.08	-1.104E-05	1.153E-02	-3.939E+00
227	29.9	(°)	5.72	-1.104E-05	1.153E-02	-3.939E+00
228	24.6	(°)	5.34	-1.104E-05	1.153E-02	-3.939E+00
229	17.9	(°)	4.87	-1.104E-05	1.153E-02	-3.939E+00
230	17.3	16.4	4.41	-1.104E-05	1.153E-02	-3.939E+00
231	22	(°)	4.05	-1.104E-05	1.153E-02	-3.939E+00
232	14.1	(°)	3.6	-1.104E-05	1.153E-02	-3.939E+00
233	5.4	1.4	3.26	-1.104E-05	1.153E-02	-3.939E+00
234	0.1	5.8	2.63	-1.104E-05	1.153E-02	-3.939E+00
235	0	0	2.18	-1.104E-05	1.153E-02	-3.939E+00
236	0	0	1.93	-1.104E-05	1.153E-02	-3.939E+00
237	0	0	1.6	-1.104E-05	1.153E-02	-3.939E+00
238	0	0	1.23	-3.680E-06	3.844E-03	-1.313E+00
239	0	0	0	3.680E-06	-3.844E-03	1.313E+00
240	0	0	0	1.104E-05	-1.153E-02	3.939E+00
249	0	0	0	1.104E-05	-1.153E-02	3.939E+00
250	1	5.3	0.19	1.104E-05	-1.153E-02	3.939E+00
251	1.1	9.9	0.83	1.104E-05	-1.153E-02	3.939E+00
252	3.4	9.1	1.57	1.104E-05	-1.153E-02	3.939E+00
253	1.1	7.6	2.11	1.104E-05	-1.153E-02	3.939E+00
254	2.8	9.5	2.28	1.104E-05	-1.153E-02	3.939E+00
255	7.7	11.8	2.49	1.104E-05	-1.153E-02	3.939E+00
256	11.9	14.4	2.66	1.104E-05	-1.153E-02	3.939E+00
257	19.1	14.4	2.98	1.104E-05	-1.153E-02	3.939E+00
258	34.6	10.2	3.64	1.104E-05	-1.153E-02	3.939E+00
259	48	9.5	4.22	1.104E-05	-1.153E-02	3.939E+00
260	57.2	10.1	4.62	1.104E-05	-1.153E-02	3.939E+00
261	52	12.7	4.84	1.104E-05	-1.153E-02	3.939E+00
262	40.4	23.7	5.03	1.104E-05	-1.153E-02	3.939E+00
263	69.3	13.6	6.67	1.104E-05	-1.153E-02	3.939E+00
264	58.9	7.7	7.26	1.104E-05	-1.153E-02	3.939E+00
265	59.1	17.7	7.77	1.104E-05	-1.153E-02	3.939E+00
266	67.1	6.2	8.37	3.680E-06	-3.844E-03	1.313E+00
267	43.5	2.9	8.25	-3.680E-06	3.844E-03	-1.313E+00
268	35.8	(°)	7.87	-1.104E-05	1.153E-02	-3.939E+00
269	24.1	(°)	6.81	-1.104E-05	1.153E-02	-3.939E+00
270	14	12.1	5.29	-1.104E-05	1.153E-02	-3.939E+00
271	18.6	9.1	3.71	-1.104E-05	1.153E-02	-3.939E+00
272	0	0	2.81	-1.104E-05	1.153E-02	-3.939E+00
273	0	0	2.43	-1.104E-05	1.153E-02	-3.939E+00
274	0	0	1.88	-1.104E-05	1.153E-02	-3.939E+00

275	0	0	1.27	-1.104E-05	1.153E-02	-3.939E+00
276	0	0	0	-1.104E-05	1.153E-02	-3.939E+00
299	0	0	0	-1.104E-05	1.153E-02	-3.939E+00
300	0	0	0	-5.060E-06	5.253E-03	-2.462E+00
301	0	0	0	9.196E-07	-1.025E-03	-9.843E-01
302	0	0	0	6.899E-06	-7.304E-03	4.932E-01
314	0	0	0	6.899E-06	-7.304E-03	4.932E-01
315	0.9	9	0.08	6.899E-06	-7.304E-03	4.932E-01
316	7.2	32.1	0.9	6.899E-06	-7.304E-03	4.932E-01
317	8.2	21.3	2.5	6.899E-06	-7.304E-03	4.932E-01
318	19.5	20.4	2.98	6.899E-06	-7.304E-03	4.932E-01
319	35.5	11	3.68	6.899E-06	-7.304E-03	4.932E-01
320	54.3	10.6	4.49	6.899E-06	-7.304E-03	4.932E-01
321	59.1	13.7	4.93	6.899E-06	-7.304E-03	4.932E-01
322	28	5.9	4.13	6.899E-06	-7.304E-03	4.932E-01
323	35	17.6	4.75	6.899E-06	-7.304E-03	4.932E-01
324	50.2	9.8	5.61	6.899E-06	-7.304E-03	4.932E-01
325	62.3	5.7	6.29	6.899E-06	-7.304E-03	4.932E-01
326	52.2	3.7	6.99	6.899E-06	-7.304E-03	4.932E-01
327	47.5	(°)	6.98	6.899E-06	-7.304E-03	4.932E-01
328	43.5	(°)	6.7	6.899E-06	-7.304E-03	4.932E-01
329	39.8	3.7	6.42	6.899E-06	-7.304E-03	4.932E-01
330	44.2	7.2	6.73	6.899E-06	-7.304E-03	4.932E-01
331	54.1	7.2	7.43	6.899E-06	-7.304E-03	4.932E-01
332	60.4	10.3	7.88	6.899E-06	-7.304E-03	4.932E-01
333	70.3	13.2	8.51	6.899E-06	-7.304E-03	4.932E-01
334	41.7	2.3	8.39	6.899E-06	-7.304E-03	4.932E-01
335	57.1	18.5	9.77	6.899E-06	-7.304E-03	4.932E-01
336	74.6	21.3	11.37	6.899E-06	-7.304E-03	4.932E-01
337	60.4	9.2	11.8	6.899E-06	-7.304E-03	4.932E-01
338	56	33.9	12.3	6.899E-06	-7.304E-03	4.932E-01
339	72.4	35.4	14.2	6.899E-06	-7.304E-03	4.932E-01
340	86.3	23.8	15.85	6.899E-06	-7.304E-03	4.932E-01
341	37	0.5	15.94	6.899E-06	-7.304E-03	4.932E-01
342	38.1	32.8	16.49	6.899E-06	-7.304E-03	4.932E-01
343	44.6	28.9	17.72	6.899E-06	-7.304E-03	4.932E-01
344	49.2	17.2	18.61	6.899E-06	-7.304E-03	4.932E-01
345	50.2	0.1	18.82	2.300E-06	-2.435E-03	1.644E-01
346	48.5	(°)	18.52	-2.300E-06	2.435E-03	-1.644E-01
347	46.7	(°)	18.17	-6.899E-06	7.304E-03	-4.932E-01
348	43.9	(°)	17.66	-6.899E-06	7.304E-03	-4.932E-01
349	41.2	(°)	17.14	-6.899E-06	7.304E-03	-4.932E-01
350	38	(°)	16.55	-6.899E-06	7.304E-03	-4.932E-01
351	34	(°)	15.8	-6.899E-06	7.304E-03	-4.932E-01
352	28.8	(°)	14.83	-6.899E-06	7.304E-03	-4.932E-01
353	21.2	(°)	13.42	-6.899E-06	7.304E-03	-4.932E-01
354	31.1	5.3	11.61	-6.899E-06	7.304E-03	-4.932E-01
355	18.6	(°)	10.13	-6.899E-06	7.304E-03	-4.932E-01
356	13	(°)	9.29	-6.899E-06	7.304E-03	-4.932E-01
357	23.6	12.3	8.6	-6.899E-06	7.304E-03	-4.932E-01
358	14.2	(°)	7.51	-6.899E-06	7.304E-03	-4.932E-01
359	14.2	5.5	5.49	-6.899E-06	7.304E-03	-4.932E-01
360	19.1	12.4	3.82	-6.899E-06	7.304E-03	-4.932E-01
361	0	0	2.45	-6.899E-06	7.304E-03	-4.932E-01
362	0.1	5.6	1.45	-6.899E-06	7.304E-03	-4.932E-01
363	0	0	0.71	-6.899E-06	7.304E-03	-4.932E-01
364	0	0	0	-6.899E-06	7.304E-03	-4.932E-01
399	0	0	0	-6.899E-06	7.304E-03	-4.932E-01
400	0	0	0	-2.724E-06	2.689E-03	2.988E-01
401	0	0	0	1.450E-06	-1.927E-03	1.091E+00
402	0	0	0	5.625E-06	-6.542E-03	1.883E+00
421	0	0	0	5.625E-06	-6.542E-03	1.883E+00
422	0.6	9.9	0.03	5.625E-06	-6.542E-03	1.883E+00
423	5	14	0.21	5.625E-06	-6.542E-03	1.883E+00
424	5.1	12.1	0.57	5.625E-06	-6.542E-03	1.883E+00
425	1.7	7.9	0.71	5.625E-06	-6.542E-03	1.883E+00

426	0.1	5.8	0.6	5.625E-06	-6.542E-03	1.883E+00
427	0	0	0	5.625E-06	-6.542E-03	1.883E+00
435	0	0	0	5.625E-06	-6.542E-03	1.883E+00
436	4.4	15.4	0.06	5.625E-06	-6.542E-03	1.883E+00
437	6	20.4	0.92	5.625E-06	-6.542E-03	1.883E+00
438	6	14.1	1.52	5.625E-06	-6.542E-03	1.883E+00
439	6	10.3	1.84	5.625E-06	-6.542E-03	1.883E+00
440	4.4	8.7	2.03	5.625E-06	-6.542E-03	1.883E+00
441	2.5	9.1	2.09	5.625E-06	-6.542E-03	1.883E+00
442	7.5	15.1	2.24	5.625E-06	-6.542E-03	1.883E+00
443	12	13.2	2.68	5.625E-06	-6.542E-03	1.883E+00
444	24.5	12.2	3.21	5.625E-06	-6.542E-03	1.883E+00
445	45.3	9.5	4.1	5.625E-06	-6.542E-03	1.883E+00
446	68.4	11.4	5.09	5.625E-06	-6.542E-03	1.883E+00
447	45.7	1.5	5.35	5.625E-06	-6.542E-03	1.883E+00
448	72.7	23	6.84	5.625E-06	-6.542E-03	1.883E+00
449	64.8	9.8	7.54	5.625E-06	-6.542E-03	1.883E+00
450	66.2	29.8	8.25	5.625E-06	-6.542E-03	1.883E+00
451	86.5	23.4	9.88	5.625E-06	-6.542E-03	1.883E+00
452	36.8	2.3	10.12	5.625E-06	-6.542E-03	1.883E+00
453	43.3	21.8	10.84	5.625E-06	-6.542E-03	1.883E+00
454	51.4	24.5	11.78	5.625E-06	-6.542E-03	1.883E+00
455	58.2	21.2	12.58	5.625E-06	-6.542E-03	1.883E+00
456	60.8	16.9	12.9	5.625E-06	-6.542E-03	1.883E+00
457	34.8	0.7	12.15	5.625E-06	-6.542E-03	1.883E+00
458	34.4	31.3	12.41	5.625E-06	-6.542E-03	1.883E+00
459	36.8	2.8	12.8	5.625E-06	-6.542E-03	1.883E+00
460	36	(°)	12.7	5.625E-06	-6.542E-03	1.883E+00
461	35.9	(°)	12.7	5.625E-06	-6.542E-03	1.883E+00
462	31.1	(°)	11.97	5.625E-06	-6.542E-03	1.883E+00
463	25	5.7	11.05	5.625E-06	-6.542E-03	1.883E+00
464	24.2	0.4	10.94	5.625E-06	-6.542E-03	1.883E+00
465	22.1	3.9	10.64	5.625E-06	-6.542E-03	1.883E+00
466	22.4	30.1	10.65	5.625E-06	-6.542E-03	1.883E+00
467	28.8	20.2	11.59	1.875E-06	-2.181E-03	6.276E-01
468	30.6	1.6	11.89	-1.875E-06	2.181E-03	-6.276E-01
469	27.9	(°)	11.5	-5.625E-06	6.542E-03	-1.883E+00
470	21.3	(°)	10.54	-5.625E-06	6.542E-03	-1.883E+00
471	13.9	(°)	9.43	-5.625E-06	6.542E-03	-1.883E+00
472	25.3	11.7	8.58	-5.625E-06	6.542E-03	-1.883E+00
473	17.8	(°)	7.91	-5.625E-06	6.542E-03	-1.883E+00
474	12.1	1.4	7.29	-5.625E-06	6.542E-03	-1.883E+00
475	24.1	(°)	6.8	-5.625E-06	6.542E-03	-1.883E+00
476	16.4	(°)	6.09	-5.625E-06	6.542E-03	-1.883E+00
477	21.6	16.5	5.65	-5.625E-06	6.542E-03	-1.883E+00
478	26.4	(°)	5.48	-5.625E-06	6.542E-03	-1.883E+00
479	16.2	(°)	4.74	-5.625E-06	6.542E-03	-1.883E+00
480	24.6	10.5	4.03	-5.625E-06	6.542E-03	-1.883E+00
481	8.2	1.1	3.27	-5.625E-06	6.542E-03	-1.883E+00
482	0	0	2.33	-5.625E-06	6.542E-03	-1.883E+00
483	0	0	1.15	-5.625E-06	6.542E-03	-1.883E+00
484	0	0	0.43	-5.625E-06	6.542E-03	-1.883E+00
485	0	0	0	-5.625E-06	6.542E-03	-1.883E+00
499	0	0	0	-5.625E-06	6.542E-03	-1.883E+00
500	0	0	0	-1.425E-06	1.947E-03	-4.329E-01
501	0	0	0	2.774E-06	-2.648E-03	1.017E+00
502	0	0	0	6.974E-06	-7.244E-03	2.467E+00
511	0	0	0	6.974E-06	-7.244E-03	2.467E+00
512	7.5	45.3	0.58	6.974E-06	-7.244E-03	2.467E+00
513	6.5	32.7	1.79	6.974E-06	-7.244E-03	2.467E+00
514	7.6	23.8	2.49	6.974E-06	-7.244E-03	2.467E+00
515	12.7	8.8	2.71	6.974E-06	-7.244E-03	2.467E+00
516	18.8	14.4	2.96	6.974E-06	-7.244E-03	2.467E+00
517	30.4	12.7	3.47	6.974E-06	-7.244E-03	2.467E+00
518	44	10.6	4.05	6.974E-06	-7.244E-03	2.467E+00
519	53.2	8.3	4.46	6.974E-06	-7.244E-03	2.467E+00

520	57.7	10	4.65	6.974E-06	-7.244E-03	2.467E+00
521	48.5	11.5	4.82	6.974E-06	-7.244E-03	2.467E+00
522	33.7	25.7	4.67	6.974E-06	-7.244E-03	2.467E+00
523	49.9	16	5.59	6.974E-06	-7.244E-03	2.467E+00
524	68.1	20.4	6.6	6.974E-06	-7.244E-03	2.467E+00
525	50.4	5.3	6.85	6.974E-06	-7.244E-03	2.467E+00
526	51.1	21.9	7.21	6.974E-06	-7.244E-03	2.467E+00
527	65	22.8	8.2	6.974E-06	-7.244E-03	2.467E+00
528	78.1	19.5	9.02	6.974E-06	-7.244E-03	2.467E+00
529	46.8	2.9	8.85	6.974E-06	-7.244E-03	2.467E+00
530	51.1	19.3	9.24	6.974E-06	-7.244E-03	2.467E+00
531	59.7	26.7	10.01	6.974E-06	-7.244E-03	2.467E+00
532	68.8	23.9	10.86	6.974E-06	-7.244E-03	2.467E+00
533	45	0.5	10.83	6.974E-06	-7.244E-03	2.467E+00
534	46.8	44.3	11.24	6.974E-06	-7.244E-03	2.467E+00
535	55.7	25	12.3	6.974E-06	-7.244E-03	2.467E+00
536	58.9	11.6	12.68	6.974E-06	-7.244E-03	2.467E+00
537	45.1	8.5	12.61	6.974E-06	-7.244E-03	2.467E+00
538	35.7	39.3	12.6	6.974E-06	-7.244E-03	2.467E+00
539	43.2	34.4	13.7	6.974E-06	-7.244E-03	2.467E+00
540	46.2	16.8	14.18	2.325E-06	-2.415E-03	8.223E-01
541	46.7	9.6	14.25	-2.325E-06	2.415E-03	-8.223E-01
542	45.6	(°)	14.1	-6.974E-06	7.244E-03	-2.467E+00
543	42.7	(°)	13.67	-6.974E-06	7.244E-03	-2.467E+00
544	38.4	(°)	13.04	-6.974E-06	7.244E-03	-2.467E+00
545	33.4	(°)	12.3	-6.974E-06	7.244E-03	-2.467E+00
546	28	(°)	11.51	-6.974E-06	7.244E-03	-2.467E+00
547	23.9	(°)	10.9	-6.974E-06	7.244E-03	-2.467E+00
548	18.9	(°)	10.18	-6.974E-06	7.244E-03	-2.467E+00
549	12.9	8.6	8.96	-6.974E-06	7.244E-03	-2.467E+00
550	15.4	(°)	7.54	-6.974E-06	7.244E-03	-2.467E+00
551	25.2	8.4	6.62	-6.974E-06	7.244E-03	-2.467E+00
552	11.1	2.8	5.48	-6.974E-06	7.244E-03	-2.467E+00
553	15.6	6.4	3.51	-6.974E-06	7.244E-03	-2.467E+00
554	0.3	13.3	2.71	-2.325E-06	2.415E-03	-8.223E-01
555	3.8	31.8	3.01	2.325E-06	-2.415E-03	8.223E-01
556	16.6	25.5	3.73	6.974E-06	-7.244E-03	2.467E+00
557	25.4	25.7	4.22	6.974E-06	-7.244E-03	2.467E+00
558	48.8	26.5	5.52	6.974E-06	-7.244E-03	2.467E+00
559	77.9	30.8	7.14	6.974E-06	-7.244E-03	2.467E+00
560	55.5	3.1	7.32	6.974E-06	-7.244E-03	2.467E+00
561	61	36.7	7.9	6.974E-06	-7.244E-03	2.467E+00
562	78.8	26.1	9.19	6.974E-06	-7.244E-03	2.467E+00
563	65.7	26	9.75	6.974E-06	-7.244E-03	2.467E+00
564	31.5	17.9	9.49	6.974E-06	-7.244E-03	2.467E+00
565	43.2	45.2	10.82	6.974E-06	-7.244E-03	2.467E+00
566	48.7	15.9	11.49	6.974E-06	-7.244E-03	2.467E+00
567	49.3	10.9	11.57	6.974E-06	-7.244E-03	2.467E+00
568	50.1	12.6	11.66	6.974E-06	-7.244E-03	2.467E+00
569	56.6	37.8	12.39	6.974E-06	-7.244E-03	2.467E+00
570	61.9	18.7	13.03	6.974E-06	-7.244E-03	2.467E+00
571	64.6	12.8	13.17	6.974E-06	-7.244E-03	2.467E+00
572	37.2	2.8	12.85	6.974E-06	-7.244E-03	2.467E+00
573	44.1	64.1	13.82	6.974E-06	-7.244E-03	2.467E+00
574	53.1	39.7	15.16	6.974E-06	-7.244E-03	2.467E+00
575	56.8	23.5	15.73	6.974E-06	-7.244E-03	2.467E+00
576	59.2	24.4	16.07	6.974E-06	-7.244E-03	2.467E+00
577	43.3	7.9	16.09	6.974E-06	-7.244E-03	2.467E+00
578	35.4	41.4	16.01	6.974E-06	-7.244E-03	2.467E+00
579	37.7	21.3	16.47	6.974E-06	-7.244E-03	2.467E+00
580	37.9	17.9	16.49	6.974E-06	-7.244E-03	2.467E+00
581	38.4	17.3	16.59	2.325E-06	-2.415E-03	8.223E-01
582	38.8	13.3	16.67	-2.325E-06	2.415E-03	-8.223E-01
583	37.4	10.8	16.41	-6.974E-06	7.244E-03	-2.467E+00
584	36.6	11.5	16.26	-6.974E-06	7.244E-03	-2.467E+00
585	34.8	6.5	15.92	-6.974E-06	7.244E-03	-2.467E+00

586	33	(°)	15.59	-6.974E-06	7.244E-03	-2.467E+00
587	29.9	(°)	15.04	-6.974E-06	7.244E-03	-2.467E+00
588	24	(°)	13.92	-6.974E-06	7.244E-03	-2.467E+00
589	29.3	13.3	12.46	-6.974E-06	7.244E-03	-2.467E+00
590	20.2	(°)	10.38	-6.974E-06	7.244E-03	-2.467E+00
591	17	14.9	8.45	-6.974E-06	7.244E-03	-2.467E+00
592	15.4	8.8	5.03	-6.974E-06	7.244E-03	-2.467E+00
593	2.5	1.3	2.58	-6.974E-06	7.244E-03	-2.467E+00
594	0.1	5.7	1.52	-6.974E-06	7.244E-03	-2.467E+00
595	0	0	1.09	-6.974E-06	7.244E-03	-2.467E+00
596	0	0	0.71	-2.325E-06	2.415E-03	-8.223E-01
597	0	0	0	2.325E-06	-2.415E-03	8.223E-01
598	0	0	0	6.974E-06	-7.244E-03	2.467E+00
599	6.4	30.8	0.13	6.974E-06	-7.244E-03	2.467E+00
600	6.8	38.6	1.14	6.974E-06	-7.244E-03	2.467E+00
601	6.7	31.6	2.17	6.974E-06	-7.244E-03	2.467E+00
602	12.7	18.1	2.71	6.974E-06	-7.244E-03	2.467E+00
603	25.1	8.8	3.25	6.974E-06	-7.244E-03	2.467E+00
604	31.3	14	3.51	6.974E-06	-7.244E-03	2.467E+00
605	48.5	8.2	4.25	6.974E-06	-7.244E-03	2.467E+00
606	57.3	7.4	4.63	6.974E-06	-7.244E-03	2.467E+00
607	49.5	15	4.48	6.974E-06	-7.244E-03	2.467E+00
608	16.2	6.7	3.48	6.974E-06	-7.244E-03	2.467E+00
609	29.3	45.7	4.41	6.974E-06	-7.244E-03	2.467E+00
610	69.5	40.4	6.66	6.974E-06	-7.244E-03	2.467E+00
611	70.3	25.8	7.73	6.974E-06	-7.244E-03	2.467E+00
612	35.7	13.9	7.84	6.974E-06	-7.244E-03	2.467E+00
613	38	4.9	8.05	6.974E-06	-7.244E-03	2.467E+00
614	37.8	4.4	8.04	6.974E-06	-7.244E-03	2.467E+00
615	37.5	4.3	8.01	6.974E-06	-7.244E-03	2.467E+00
616	37.3	4.3	7.99	6.974E-06	-7.244E-03	2.467E+00
617	37	4.4	7.96	6.974E-06	-7.244E-03	2.467E+00
618	36.7	4.4	7.94	6.974E-06	-7.244E-03	2.467E+00
619	36.5	4.5	7.92	6.974E-06	-7.244E-03	2.467E+00
620	36.9	12.3	7.95	6.974E-06	-7.244E-03	2.467E+00
621	44.6	20.6	8.65	6.974E-06	-7.244E-03	2.467E+00
622	51.4	10.4	9.28	6.974E-06	-7.244E-03	2.467E+00
623	53.7	(°)	9.49	6.974E-06	-7.244E-03	2.467E+00
624	53.5	(°)	9.48	6.974E-06	-7.244E-03	2.467E+00
625	54.2	16.7	9.52	6.974E-06	-7.244E-03	2.467E+00
626	62.2	18.4	10.26	6.974E-06	-7.244E-03	2.467E+00
627	65.7	8.9	10.78	6.974E-06	-7.244E-03	2.467E+00
628	43.8	(°)	10.94	6.974E-06	-7.244E-03	2.467E+00
629	42.4	1.5	10.77	6.974E-06	-7.244E-03	2.467E+00
630	41.8	4.6	10.7	6.974E-06	-7.244E-03	2.467E+00
631	41.6	5.1	10.67	6.974E-06	-7.244E-03	2.467E+00
632	41.4	5.1	10.66	6.974E-06	-7.244E-03	2.467E+00
633	41.3	5.2	10.65	6.974E-06	-7.244E-03	2.467E+00
634	41.2	5.2	10.63	6.974E-06	-7.244E-03	2.467E+00
635	41.1	5.2	10.62	6.974E-06	-7.244E-03	2.467E+00
636	41	5.2	10.61	6.974E-06	-7.244E-03	2.467E+00
637	41	5.3	10.6	6.974E-06	-7.244E-03	2.467E+00
638	40.9	5.3	10.59	6.974E-06	-7.244E-03	2.467E+00
639	40.8	5.3	10.58	6.974E-06	-7.244E-03	2.467E+00
640	40.7	5.3	10.58	6.974E-06	-7.244E-03	2.467E+00
641	42.1	13.3	10.73	6.974E-06	-7.244E-03	2.467E+00
642	45.4	13.6	11.11	6.974E-06	-7.244E-03	2.467E+00
643	50.5	9.9	11.71	6.974E-06	-7.244E-03	2.467E+00
644	53.2	5.7	12.03	6.974E-06	-7.244E-03	2.467E+00
645	54.6	(°)	12.2	6.974E-06	-7.244E-03	2.467E+00
646	53.9	0.3	12.12	6.974E-06	-7.244E-03	2.467E+00
647	53.3	4.7	12.04	6.974E-06	-7.244E-03	2.467E+00
648	53.1	5.3	12.02	6.974E-06	-7.244E-03	2.467E+00
649	53.1	5.4	12.01	4.837E-06	-5.146E-03	1.740E+00
650	53	5.4	12.01	2.700E-06	-3.048E-03	1.013E+00
651	53	5.4	12	5.632E-07	-9.497E-04	2.854E-01

652	52.9	5.4	12	5.632E-07	-9.497E-04	2.854E-01
653	52.9	5.4	12	5.632E-07	-9.497E-04	2.854E-01
654	52.9	5.4	11.99	5.632E-07	-9.497E-04	2.854E-01
655	52.8	5.4	11.99	5.632E-07	-9.497E-04	2.854E-01
656	52.8	5.4	11.98	5.632E-07	-9.497E-04	2.854E-01
657	52.8	5.4	11.98	5.632E-07	-9.497E-04	2.854E-01
658	52.8	5.4	11.98	5.632E-07	-9.497E-04	2.854E-01
659	52.7	5.4	11.97	5.632E-07	-9.497E-04	2.854E-01
660	55.2	16.3	12.25	5.632E-07	-9.497E-04	2.854E-01
661	58.7	16.1	12.65	5.632E-07	-9.497E-04	2.854E-01
662	54	10.8	12.89	5.632E-07	-9.497E-04	2.854E-01
663	38.1	35.5	12.97	5.632E-07	-9.497E-04	2.854E-01
664	44.3	23.7	13.88	5.632E-07	-9.497E-04	2.854E-01
665	46.3	1.7	14.19	5.632E-07	-9.497E-04	2.854E-01
666	46.4	(°)	14.22	5.632E-07	-9.497E-04	2.854E-01
667	45.8	7.8	14.11	5.632E-07	-9.497E-04	2.854E-01
668	50.4	34.7	14.77	5.632E-07	-9.497E-04	2.854E-01
669	54.7	15.2	15.43	5.632E-07	-9.497E-04	2.854E-01
670	57.6	(°)	15.88	5.632E-07	-9.497E-04	2.854E-01
671	54.1	(°)	15.37	5.632E-07	-9.497E-04	2.854E-01
672	52.1	(°)	15.06	5.632E-07	-9.497E-04	2.854E-01
673	52	(°)	15.04	5.632E-07	-9.497E-04	2.854E-01
674	51.3	5.7	14.94	5.632E-07	-9.497E-04	2.854E-01
675	51.3	6.8	14.93	5.632E-07	-9.497E-04	2.854E-01
676	51.6	11.2	14.97	5.632E-07	-9.497E-04	2.854E-01
677	54.2	11.5	15.35	5.632E-07	-9.497E-04	2.854E-01
678	54.7	16.5	15.43	5.632E-07	-9.497E-04	2.854E-01
679	54.4	22.6	15.38	5.632E-07	-9.497E-04	2.854E-01
680	55.3	8.6	15.52	5.632E-07	-9.497E-04	2.854E-01
681	55.8	1.3	15.6	5.632E-07	-9.497E-04	2.854E-01
682	55.5	4.3	15.56	5.632E-07	-9.497E-04	2.854E-01
683	55.3	6.3	15.53	5.632E-07	-9.497E-04	2.854E-01
684	55.3	6.5	15.52	5.632E-07	-9.497E-04	2.854E-01
685	55.3	6.5	15.52	5.632E-07	-9.497E-04	2.854E-01
686	55.3	6.5	15.52	5.632E-07	-9.497E-04	2.854E-01
687	55.3	6.5	15.51	5.632E-07	-9.497E-04	2.854E-01
688	55.2	4.8	15.51	5.632E-07	-9.497E-04	2.854E-01
689	54.4	2.7	15.39	5.632E-07	-9.497E-04	2.854E-01
690	55.2	(°)	15.52	5.632E-07	-9.497E-04	2.854E-01
691	54.2	13.3	15.36	5.632E-07	-9.497E-04	2.854E-01
692	54.1	11.8	15.34	5.632E-07	-9.497E-04	2.854E-01
693	54.7	5.3	15.43	5.632E-07	-9.497E-04	2.854E-01
694	55.4	(°)	15.54	5.632E-07	-9.497E-04	2.854E-01
695	54.9	1.9	15.46	5.632E-07	-9.497E-04	2.854E-01
696	54.5	6.2	15.4	5.632E-07	-9.497E-04	2.854E-01
697	54.5	7.2	15.41	5.632E-07	-9.497E-04	2.854E-01
698	54.5	6.3	15.41	5.632E-07	-9.497E-04	2.854E-01
699	54	(°)	15.33	4.087E-07	-8.219E-04	3.495E-01
700	54.8	(°)	15.46	2.542E-07	-6.940E-04	4.136E-01
701	54.1	(°)	15.36	9.973E-08	-5.661E-04	4.778E-01
702	53.2	6.7	15.21	9.973E-08	-5.661E-04	4.778E-01
703	53.5	5.8	15.25	9.973E-08	-5.661E-04	4.778E-01
704	53	(°)	15.19	9.973E-08	-5.661E-04	4.778E-01
705	50.9	8.6	14.87	9.973E-08	-5.661E-04	4.778E-01
706	50.7	11.7	14.84	9.973E-08	-5.661E-04	4.778E-01
707	51.1	7.8	14.9	9.973E-08	-5.661E-04	4.778E-01
708	51.2	6.6	14.92	9.973E-08	-5.661E-04	4.778E-01
709	51.2	6.5	14.92	9.973E-08	-5.661E-04	4.778E-01
710	51.2	6.5	14.92	9.973E-08	-5.661E-04	4.778E-01
711	51.2	6.5	14.92	9.973E-08	-5.661E-04	4.778E-01
712	51.3	6.5	14.92	9.973E-08	-5.661E-04	4.778E-01
713	51.3	6.5	14.92	9.973E-08	-5.661E-04	4.778E-01
714	51.3	6.5	14.93	9.973E-08	-5.661E-04	4.778E-01
732	51.3	6.5	14.93	9.973E-08	-5.661E-04	4.778E-01
733	51.3	6.5	14.94	9.973E-08	-5.661E-04	4.778E-01
734	51.4	10.5	14.95	9.973E-08	-5.661E-04	4.778E-01

735	53.1	11.2	15.19	9.973E-08	-5.661E-04	4.778E-01
736	52.9	5.3	15.17	9.973E-08	-5.661E-04	4.778E-01
737	53.8	2.9	15.3	9.973E-08	-5.661E-04	4.778E-01
738	55.5	(^e)	15.56	9.973E-08	-5.661E-04	4.778E-01
739	55.1	2	15.5	9.973E-08	-5.661E-04	4.778E-01
740	55.7	6.8	15.58	9.973E-08	-5.661E-04	4.778E-01
741	55.9	5.3	15.61	9.973E-08	-5.661E-04	4.778E-01
742	54.1	18	15.33	9.973E-08	-5.661E-04	4.778E-01
743	53.9	14.8	15.3	9.973E-08	-5.661E-04	4.778E-01
744	55	9.5	15.47	9.973E-08	-5.661E-04	4.778E-01
745	55.4	1.9	15.54	9.973E-08	-5.661E-04	4.778E-01
746	55.7	8.4	15.58	9.973E-08	-5.661E-04	4.778E-01
747	57.4	(^e)	15.85	9.973E-08	-5.661E-04	4.778E-01
748	56.7	(^e)	15.77	9.973E-08	-5.661E-04	4.778E-01
749	32.2	(^e)	15.36	9.973E-08	-5.661E-04	4.778E-01
750	30.2	25.4	15.05	9.973E-08	-5.661E-04	4.778E-01
751	28.9	43.8	14.8	9.973E-08	-5.661E-04	4.778E-01
752	29.6	37.9	14.93	9.973E-08	-5.661E-04	4.778E-01
753	30.5	13.4	15.11	3.324E-08	-1.887E-04	1.593E-01
754	30.6	(^e)	15.14	-3.324E-08	1.887E-04	-1.593E-01
755	29.2	(^e)	14.88	-9.973E-08	5.661E-04	-4.778E-01
756	28.7	(^e)	14.79	-9.973E-08	5.661E-04	-4.778E-01
757	28.2	(^e)	14.69	-9.973E-08	5.661E-04	-4.778E-01
758	27.7	8.5	14.6	-9.973E-08	5.661E-04	-4.778E-01
759	27.5	(^e)	14.55	-9.973E-08	5.661E-04	-4.778E-01
760	24.9	(^e)	14.09	-9.973E-08	5.661E-04	-4.778E-01
761	23.1	(^e)	13.76	-9.973E-08	5.661E-04	-4.778E-01
762	21	8.9	12.81	-9.973E-08	5.661E-04	-4.778E-01
763	34.4	(^e)	12.32	-9.973E-08	5.661E-04	-4.778E-01
764	30.1	(^e)	11.83	-9.973E-08	5.661E-04	-4.778E-01
765	22.8	(^e)	10.76	-9.973E-08	5.661E-04	-4.778E-01
766	13.2	(^e)	9.35	-9.973E-08	5.661E-04	-4.778E-01
767	17.9	7.1	7.87	-9.973E-08	5.661E-04	-4.778E-01
768	21.7	10.3	6.32	-9.973E-08	5.661E-04	-4.778E-01
769	15.3	(^e)	4.47	-9.973E-08	5.661E-04	-4.778E-01
770	0.9	(^e)	2.49	-9.973E-08	5.661E-04	-4.778E-01
771	0.1	5.6	1.67	-9.973E-08	5.661E-04	-4.778E-01
772	0	0	1.55	-9.973E-08	5.661E-04	-4.778E-01
773	0	0	1.46	-9.973E-08	5.661E-04	-4.778E-01
774	0	0	0.71	-9.973E-08	5.661E-04	-4.778E-01
775	0	0	0	-9.973E-08	5.661E-04	-4.778E-01
799	0	0	0	-9.973E-08	5.661E-04	-4.778E-01
800	0	0	0	3.522E-06	-3.252E-03	6.821E-01
801	0	0	0	7.144E-06	-7.070E-03	1.842E+00
802	0	0	0	1.077E-05	-1.089E-02	3.002E+00
810	0	0	0	1.077E-05	-1.089E-02	3.002E+00
811	7.7	34.4	1.28	1.077E-05	-1.089E-02	3.002E+00
812	16.2	15.7	2.87	1.077E-05	-1.089E-02	3.002E+00
813	37.9	5.1	3.79	1.077E-05	-1.089E-02	3.002E+00
814	51.4	10.8	4.37	1.077E-05	-1.089E-02	3.002E+00
815	71.1	18.9	5.19	1.077E-05	-1.089E-02	3.002E+00
816	49.8	(^e)	5.6	1.077E-05	-1.089E-02	3.002E+00
817	65.6	18.1	6.47	1.077E-05	-1.089E-02	3.002E+00
818	43.5	4.8	6.4	1.077E-05	-1.089E-02	3.002E+00
819	47.4	35.6	6.93	1.077E-05	-1.089E-02	3.002E+00
820	73	32.8	8.77	1.077E-05	-1.089E-02	3.002E+00
821	76.2	29	9.82	1.077E-05	-1.089E-02	3.002E+00
822	33.1	6.8	9.69	1.077E-05	-1.089E-02	3.002E+00
823	44.9	51	11.01	1.077E-05	-1.089E-02	3.002E+00
824	60.1	44.1	12.8	1.077E-05	-1.089E-02	3.002E+00
825	67	22.5	13.62	1.077E-05	-1.089E-02	3.002E+00
826	72.5	28.6	14.25	1.077E-05	-1.089E-02	3.002E+00
827	46	2.8	13.95	1.077E-05	-1.089E-02	3.002E+00
828	51	60.5	14.84	1.077E-05	-1.089E-02	3.002E+00
829	63	33.5	16.62	1.077E-05	-1.089E-02	3.002E+00
830	65.5	25.2	17	1.077E-05	-1.089E-02	3.002E+00

831	57.8	12.7	17.13	1.077E-05	-1.089E-02	3.002E+00
832	40.4	36	16.96	1.077E-05	-1.089E-02	3.002E+00
833	43.6	24.7	17.56	1.077E-05	-1.089E-02	3.002E+00
834	44.1	21.8	17.66	3.588E-06	-3.630E-03	1.001E+00
835	45	10.9	17.84	-3.588E-06	3.630E-03	-1.001E+00
836	44.3	(°)	17.71	-1.077E-05	1.089E-02	-3.002E+00
837	42	(°)	17.28	-1.077E-05	1.089E-02	-3.002E+00
838	38.5	(°)	16.63	-1.077E-05	1.089E-02	-3.002E+00
839	35.3	(°)	16.03	-1.077E-05	1.089E-02	-3.002E+00
840	31.3	(°)	15.29	-1.077E-05	1.089E-02	-3.002E+00
841	24.9	(°)	14.1	-1.077E-05	1.089E-02	-3.002E+00
842	29.1	12.7	12.28	-1.077E-05	1.089E-02	-3.002E+00
843	20.4	(°)	10.41	-1.077E-05	1.089E-02	-3.002E+00
844	14.7	12.9	8.82	-1.077E-05	1.089E-02	-3.002E+00
845	14.7	(°)	7.57	-1.077E-05	1.089E-02	-3.002E+00
846	17.2	6.5	5.93	-1.077E-05	1.089E-02	-3.002E+00
847	16.7	12.3	3.77	-1.077E-05	1.089E-02	-3.002E+00
848	0	0	1.51	-1.077E-05	1.089E-02	-3.002E+00
849	0	0	0	-1.077E-05	1.089E-02	-3.002E+00
864	0	0	0	-1.077E-05	1.089E-02	-3.002E+00
865	0	0	0	-3.199E-06	3.169E-03	-1.698E+00
866	0	0	0	4.367E-06	-4.551E-03	-3.934E-01
867	0	0	0	1.193E-05	-1.227E-02	9.108E-01
869	0	0	0	1.193E-05	-1.227E-02	9.108E-01
870	3	5	0	1.193E-05	-1.227E-02	9.108E-01
871	7	10	0	1.193E-05	-1.227E-02	9.108E-01
872	58.6	22.6	5.59	1.193E-05	-1.227E-02	9.108E-01
873	84.8	19.9	6.92	1.193E-05	-1.227E-02	9.108E-01
874	46.7	3.3	6.66	1.193E-05	-1.227E-02	9.108E-01
875	51.2	10.4	7.09	1.193E-05	-1.227E-02	9.108E-01
876	56.5	10.6	7.46	1.193E-05	-1.227E-02	9.108E-01
877	70.3	14.4	8.4	1.193E-05	-1.227E-02	9.108E-01
878	53.2	10.4	8.86	1.193E-05	-1.227E-02	9.108E-01
879	50.4	34.3	9.51	9.979E-06	-1.043E-02	9.264E-01
880	81.5	54.8	12.38	8.023E-06	-8.594E-03	9.420E-01
881	91.3	5.4	13.38	6.068E-06	-6.755E-03	9.576E-01
882	63.6	10.3	13.29	6.068E-06	-6.755E-03	9.576E-01
883	57.9	37.8	13.65	6.068E-06	-6.755E-03	9.576E-01
884	80.1	61.2	16.37	6.068E-06	-6.755E-03	9.576E-01
885	89.5	24	17.62	6.068E-06	-6.755E-03	9.576E-01
886	60.8	7.4	17.9	6.068E-06	-6.755E-03	9.576E-01
887	57.2	41.9	18.28	6.068E-06	-6.755E-03	9.576E-01
888	65.4	8.4	19.71	6.068E-06	-6.755E-03	9.576E-01
889	65.6	5.5	19.75	5.713E-06	-6.392E-03	4.768E-01
890	35.9	0.3	19.56	5.358E-06	-6.028E-03	-3.992E-03
891	35.4	31.2	19.87	5.004E-06	-5.665E-03	-4.848E-01
892	37.3	19	20.32	5.004E-06	-5.665E-03	-4.848E-01
893	40.5	38	21	5.004E-06	-5.665E-03	-4.848E-01
894	46.4	56.4	22.32	5.004E-06	-5.665E-03	-4.848E-01
895	52.5	39.6	23.74	5.004E-06	-5.665E-03	-4.848E-01
896	54.6	7.8	24.26	5.004E-06	-5.665E-03	-4.848E-01
897	53.3	(°)	23.98	5.004E-06	-5.665E-03	-4.848E-01
898	51.2	(°)	23.51	5.004E-06	-5.665E-03	-4.848E-01
899	49.3	(°)	23.08	3.154E-06	-3.810E-03	-3.535E-01
900	47.4	(°)	22.66	1.304E-06	-1.954E-03	-2.222E-01
901	46	6.4	22.31	-5.462E-07	-9.930E-05	-9.097E-02
902	45.9	7.6	22.29	-5.462E-07	-9.930E-05	-9.097E-02
903	46.4	18.3	22.38	-5.462E-07	-9.930E-05	-9.097E-02
904	48.1	23.5	22.75	-5.462E-07	-9.930E-05	-9.097E-02
905	50	22.5	23.2	-5.462E-07	-9.930E-05	-9.097E-02
906	50.5	8.6	23.34	-5.462E-07	-9.930E-05	-9.097E-02
907	48.9	(°)	22.99	-5.462E-07	-9.930E-05	-9.097E-02
908	48.2	11	22.8	-5.462E-07	-9.930E-05	-9.097E-02
909	47.5	3.6	22.66	9.609E-07	-1.656E-03	1.853E-01
910	48.3	14.9	22.82	2.468E-06	-3.213E-03	4.616E-01
911	48.7	13	22.92	3.975E-06	-4.769E-03	7.379E-01

912	47.8	(^e)	22.74	3.975E-06	-4.769E-03	7.379E-01
913	47.8	14.5	22.71	3.975E-06	-4.769E-03	7.379E-01
914	48.3	10.1	22.82	3.975E-06	-4.769E-03	7.379E-01
915	48.3	6.4	22.84	3.975E-06	-4.769E-03	7.379E-01
916	48.2	7	22.8	3.975E-06	-4.769E-03	7.379E-01
917	48.3	12.5	22.83	3.975E-06	-4.769E-03	7.379E-01
918	48.1	6.6	22.79	3.975E-06	-4.769E-03	7.379E-01
919	48.2	12.1	22.79	3.975E-06	-4.769E-03	7.379E-01
920	49.2	17.9	23.02	1.325E-06	-1.590E-03	2.460E-01
921	50.7	11.7	23.36	-1.325E-06	1.590E-03	-2.460E-01
922	49.4	(^e)	23.1	-3.975E-06	4.769E-03	-7.379E-01
923	47.2	(^e)	22.61	-3.975E-06	4.769E-03	-7.379E-01
924	44.8	(^e)	22.06	-3.975E-06	4.769E-03	-7.379E-01
925	42.1	(^e)	21.45	-3.975E-06	4.769E-03	-7.379E-01
926	39.1	(^e)	20.76	-3.975E-06	4.769E-03	-7.379E-01
927	36.2	(^e)	20.11	-3.975E-06	4.769E-03	-7.379E-01
928	33.5	(^e)	19.48	-3.975E-06	4.769E-03	-7.379E-01
929	29.8	(^e)	18.65	-3.975E-06	4.769E-03	-7.379E-01
930	25.1	(^e)	17.59	-3.975E-06	4.769E-03	-7.379E-01
931	20.4	(^e)	16.52	-3.975E-06	4.769E-03	-7.379E-01
932	23.8	13.5	15.18	-3.975E-06	4.769E-03	-7.379E-01
933	29.8	1.8	13.26	-3.975E-06	4.769E-03	-7.379E-01
934	15.6	(^e)	11.39	-3.975E-06	4.769E-03	-7.379E-01
935	19.4	14.3	9.71	-3.975E-06	4.769E-03	-7.379E-01
936	16.1	(^e)	8.52	-3.975E-06	4.769E-03	-7.379E-01
937	16.3	13.1	6.98	-3.975E-06	4.769E-03	-7.379E-01
938	17.8	11.5	4.9	-3.975E-06	4.769E-03	-7.379E-01
939	8.6	1.8	2.92	-3.975E-06	4.769E-03	-7.379E-01
940	0	0	2.39	-3.975E-06	4.769E-03	-7.379E-01
941	0	0	2.44	-3.975E-06	4.769E-03	-7.379E-01
942	0	0	2.37	-3.975E-06	4.769E-03	-7.379E-01
943	1	5	1.67	-3.975E-06	4.769E-03	-7.379E-01
944	5	8.7	1.17	-3.975E-06	4.769E-03	-7.379E-01
945	5.4	7.6	1.34	-3.975E-06	4.769E-03	-7.379E-01
946	0	0	1.28	-3.975E-06	4.769E-03	-7.379E-01
947	0	0	0.56	-1.325E-06	1.590E-03	-2.460E-01
948	0	0	0	1.325E-06	-1.590E-03	2.460E-01
949	0	0	0	3.975E-06	-4.769E-03	7.379E-01
952	0	0	0	3.975E-06	-4.769E-03	7.379E-01
953	5.4	16.3	0.27	3.975E-06	-4.769E-03	7.379E-01
954	7.2	26	1.4	3.975E-06	-4.769E-03	7.379E-01
955	27.1	23	2.96	3.975E-06	-4.769E-03	7.379E-01
956	64.4	18	4.35	3.975E-06	-4.769E-03	7.379E-01
957	44.8	3.7	4.75	3.975E-06	-4.769E-03	7.379E-01
958	60.6	28.7	5.67	3.975E-06	-4.769E-03	7.379E-01
959	92.5	23.9	7.29	3.975E-06	-4.769E-03	7.379E-01
960	53	1.3	7.23	3.975E-06	-4.769E-03	7.379E-01
961	85.2	41.6	9.37	3.975E-06	-4.769E-03	7.379E-01
962	56.3	0.4	9.93	3.975E-06	-4.769E-03	7.379E-01
963	67.8	48.8	11.11	3.975E-06	-4.769E-03	7.379E-01
964	101.7	55.3	13.96	3.975E-06	-4.769E-03	7.379E-01
965	31.9	2.4	13.82	3.975E-06	-4.769E-03	7.379E-01
966	37.3	57.2	14.93	3.975E-06	-4.769E-03	7.379E-01
967	54.7	82.5	17.81	3.975E-06	-4.769E-03	7.379E-01
968	64.3	12.2	19.52	3.975E-06	-4.769E-03	7.379E-01
969	65.1	8.7	19.67	3.461E-06	-4.200E-03	7.130E-01
970	36.8	1	19.69	2.947E-06	-3.630E-03	6.882E-01
971	35.5	20.2	19.9	2.433E-06	-3.060E-03	6.633E-01
972	36.9	14.6	20.23	2.433E-06	-3.060E-03	6.633E-01
973	38.2	14.8	20.52	2.433E-06	-3.060E-03	6.633E-01
974	38.9	8	20.69	8.109E-07	-1.020E-03	2.211E-01
975	39	7.7	20.7	-8.109E-07	1.020E-03	-2.211E-01
976	37.5	(^e)	20.38	-2.433E-06	3.060E-03	-6.633E-01
977	35.6	(^e)	19.95	-2.433E-06	3.060E-03	-6.633E-01
978	33.1	(^e)	19.4	-2.433E-06	3.060E-03	-6.633E-01
979	30	(^e)	18.69	-2.433E-06	3.060E-03	-6.633E-01

980	26.2	(^e)	17.83	-2.433E-06	3.060E-03	-6.633E-01
981	21.9	(^e)	16.86	-2.433E-06	3.060E-03	-6.633E-01
982	18.1	(^e)	15.98	-2.433E-06	3.060E-03	-6.633E-01
983	40.7	16.1	15.23	-2.433E-06	3.060E-03	-6.633E-01
984	36	(^e)	14.81	-2.433E-06	3.060E-03	-6.633E-01
985	33.7	(^e)	14.4	-2.433E-06	3.060E-03	-6.633E-01
986	32	(^e)	14.12	-2.433E-06	3.060E-03	-6.633E-01
987	29.3	(^e)	13.67	-2.433E-06	3.060E-03	-6.633E-01
988	27	(^e)	13.29	-2.433E-06	3.060E-03	-6.633E-01
989	24.6	(^e)	12.89	-2.433E-06	3.060E-03	-6.633E-01
990	21.8	(^e)	12.41	-2.433E-06	3.060E-03	-6.633E-01
991	18.2	(^e)	11.82	-2.433E-06	3.060E-03	-6.633E-01
992	9.9	6.7	9.97	-2.433E-06	3.060E-03	-6.633E-01
993	16	2.1	8.01	-2.433E-06	3.060E-03	-6.633E-01
994	13.4	4	5.89	-2.433E-06	3.060E-03	-6.633E-01
995	11.3	5.7	3.93	-2.433E-06	3.060E-03	-6.633E-01
996	0	0	2.5	-2.433E-06	3.060E-03	-6.633E-01
997	0.3	3.9	2.18	-2.433E-06	3.060E-03	-6.633E-01
998	0.2	3.5	1.91	-2.433E-06	3.060E-03	-6.633E-01
999	0	0	2.01	-2.433E-06	3.060E-03	-6.633E-01
1000	0	0	2.13	-2.433E-06	3.060E-03	-6.633E-01
1001	0	0	2.04	-2.433E-06	3.060E-03	-6.633E-01
1002	0	0	0.61	-2.433E-06	3.060E-03	-6.633E-01
1003	0	0	0	-2.433E-06	3.060E-03	-6.633E-01
1014	0	0	0	-2.433E-06	3.060E-03	-6.633E-01
1015	0	0	0	-1.410E-06	1.623E-03	-4.817E-01
1016	0	0	0	-3.875E-07	1.855E-04	-3.001E-01
1017	1	7.6	0.01	6.352E-07	-1.252E-03	-1.186E-01
1018	7.8	34.2	0.94	6.352E-07	-1.252E-03	-1.186E-01
1019	27.5	19.7	2.99	6.352E-07	-1.252E-03	-1.186E-01
1020	67.8	18.4	4.47	6.352E-07	-1.252E-03	-1.186E-01
1021	39.9	5.8	4.45	6.352E-07	-1.252E-03	-1.186E-01
1022	39.1	27.8	4.59	6.352E-07	-1.252E-03	-1.186E-01
1023	90.5	36.7	7.17	6.352E-07	-1.252E-03	-1.186E-01
1024	55.7	1.3	7.32	6.352E-07	-1.252E-03	-1.186E-01
1025	81.4	46.8	9.1	6.352E-07	-1.252E-03	-1.186E-01
1026	56.6	2.7	9.86	6.352E-07	-1.252E-03	-1.186E-01
1027	62.2	36.5	10.61	6.352E-07	-1.252E-03	-1.186E-01
1028	81	44.1	12.35	6.352E-07	-1.252E-03	-1.186E-01
1029	64.2	11	13.32	6.352E-07	-1.252E-03	-1.186E-01
1030	56.2	37.2	13.44	6.352E-07	-1.252E-03	-1.186E-01
1031	77.1	77.9	15.98	6.352E-07	-1.252E-03	-1.186E-01
1032	103.6	47.7	18.47	6.352E-07	-1.252E-03	-1.186E-01
1033	56.1	2.9	18.15	6.352E-07	-1.252E-03	-1.186E-01
1034	65	62.1	19.55	6.352E-07	-1.252E-03	-1.186E-01
1035	72.1	27.2	20.81	6.352E-07	-1.252E-03	-1.186E-01
1036	75	19.5	21.31	6.352E-07	-1.252E-03	-1.186E-01
1037	42.6	1.6	21.12	6.352E-07	-1.252E-03	-1.186E-01
1038	43.4	47.9	21.65	6.352E-07	-1.252E-03	-1.186E-01
1039	47.3	26.8	22.57	6.352E-07	-1.252E-03	-1.186E-01
1040	49	21.4	22.98	6.352E-07	-1.252E-03	-1.186E-01
1041	50.5	23.2	23.32	6.352E-07	-1.252E-03	-1.186E-01
1042	51.9	20.3	23.63	6.352E-07	-1.252E-03	-1.186E-01
1043	53.2	19.4	23.92	6.352E-07	-1.252E-03	-1.186E-01
1044	54.1	14.5	24.14	6.352E-07	-1.252E-03	-1.186E-01
1045	54	6.5	24.13	6.352E-07	-1.252E-03	-1.186E-01
1046	54.9	26.4	24.3	6.352E-07	-1.252E-03	-1.186E-01
1047	58	38	24.99	6.352E-07	-1.252E-03	-1.186E-01
1048	60.7	25.2	25.63	6.352E-07	-1.252E-03	-1.186E-01
1049	32.4	(^e)	25.39	6.352E-07	-1.252E-03	-1.186E-01
1050	29.8	7.6	25.06	6.352E-07	-1.252E-03	-1.186E-01
1051	28.4	(^e)	24.66	6.352E-07	-1.252E-03	-1.186E-01
1052	26.2	(^e)	23.99	6.352E-07	-1.252E-03	-1.186E-01
1053	25.2	14.1	23.63	6.352E-07	-1.252E-03	-1.186E-01
1054	26.9	47.6	24.13	6.352E-07	-1.252E-03	-1.186E-01
1055	30.5	70.4	25.2	6.352E-07	-1.252E-03	-1.186E-01

1056	32.1	12.2	25.77	6.352E-07	-1.252E-03	-1.186E-01
1057	32.6	26.7	25.89	6.352E-07	-1.252E-03	-1.186E-01
1058	34.5	44	26.46	6.352E-07	-1.252E-03	-1.186E-01
1059	36.5	34.5	27.06	6.352E-07	-1.252E-03	-1.186E-01
1060	37.7	26.5	27.46	6.352E-07	-1.252E-03	-1.186E-01
1061	38.6	23.3	27.72	6.352E-07	-1.252E-03	-1.186E-01
1062	39.3	20.6	27.95	6.352E-07	-1.252E-03	-1.186E-01
1063	39.6	19.9	28.03	6.352E-07	-1.252E-03	-1.186E-01
1064	40.1	23.2	28.19	6.352E-07	-1.252E-03	-1.186E-01
1065	40.7	25.2	28.38	6.352E-07	-1.252E-03	-1.186E-01
1066	41.6	27.3	28.64	6.352E-07	-1.252E-03	-1.186E-01
1067	42.4	23.5	28.9	6.352E-07	-1.252E-03	-1.186E-01
1068	42.9	22.5	29.04	6.352E-07	-1.252E-03	-1.186E-01
1069	43.2	15.8	29.14	6.352E-07	-1.252E-03	-1.186E-01
1070	43.1	15.6	29.13	6.352E-07	-1.252E-03	-1.186E-01
1071	43.2	17.1	29.17	6.352E-07	-1.252E-03	-1.186E-01
1072	43.2	13.8	29.17	6.352E-07	-1.252E-03	-1.186E-01
1073	43.2	14.7	29.15	6.352E-07	-1.252E-03	-1.186E-01
1074	43	22.7	29.09	6.352E-07	-1.252E-03	-1.186E-01
1075	43.8	24.6	29.31	6.352E-07	-1.252E-03	-1.186E-01
1076	44.2	13.7	29.46	6.352E-07	-1.252E-03	-1.186E-01
1077	44	6.9	29.39	6.352E-07	-1.252E-03	-1.186E-01
1078	42.9	(^c)	29.08	6.352E-07	-1.252E-03	-1.186E-01
1079	41.4	2.9	28.62	6.352E-07	-1.252E-03	-1.186E-01
1080	41	14	28.48	6.352E-07	-1.252E-03	-1.186E-01
1081	41.1	17.7	28.5	6.352E-07	-1.252E-03	-1.186E-01
1082	41.7	15	28.69	6.352E-07	-1.252E-03	-1.186E-01
1083	42.4	19.8	28.91	6.352E-07	-1.252E-03	-1.186E-01
1084	43.5	17.4	29.24	6.352E-07	-1.252E-03	-1.186E-01
1085	44	10.8	29.41	6.352E-07	-1.252E-03	-1.186E-01
1086	44.3	10	29.51	6.352E-07	-1.252E-03	-1.186E-01
1087	44.5	6.5	29.55	6.352E-07	-1.252E-03	-1.186E-01
1088	44.1	0.4	29.46	6.352E-07	-1.252E-03	-1.186E-01
1089	43.4	1.2	29.24	6.352E-07	-1.252E-03	-1.186E-01
1090	43.2	7.3	29.17	6.352E-07	-1.252E-03	-1.186E-01
1091	43.1	4.7	29.14	6.352E-07	-1.252E-03	-1.186E-01
1092	42.8	4.7	29.04	6.352E-07	-1.252E-03	-1.186E-01
1093	42.6	5.8	28.97	6.352E-07	-1.252E-03	-1.186E-01
1094	42.6	9.8	28.97	6.352E-07	-1.252E-03	-1.186E-01
1095	42.9	13.4	29.06	6.352E-07	-1.252E-03	-1.186E-01
1096	43.4	19	29.22	6.352E-07	-1.252E-03	-1.186E-01
1097	44.2	15	29.47	6.352E-07	-1.252E-03	-1.186E-01
1098	44.6	11.5	29.59	6.352E-07	-1.252E-03	-1.186E-01
1099	44.8	5.5	29.66	3.896E-07	-1.022E-03	-3.475E-01
1100	44.1	(^e)	29.47	1.440E-07	-7.913E-04	-5.765E-01
1101	43.1	(^e)	29.25	-1.016E-07	-5.610E-04	-8.055E-01
1102	42.8	10.3	29.03	-1.016E-07	-5.610E-04	-8.055E-01
1103	43	0.7	29.1	-1.016E-07	-5.610E-04	-8.055E-01
1104	42	(^e)	28.82	-1.016E-07	-5.610E-04	-8.055E-01
1105	41.3	(^e)	28.60	-1.016E-07	-5.610E-04	-8.055E-01
1106	40.7	(^e)	28.41	-1.016E-07	-5.610E-04	-8.055E-01
1107	40	1.3	28.19	-1.016E-07	-5.610E-04	-8.055E-01
1108	39.6	6.1	28.07	-1.016E-07	-5.610E-04	-8.055E-01
1109	39.4	2.4	28.01	-1.016E-07	-5.610E-04	-8.055E-01
1110	38.8	(^e)	27.84	-1.016E-07	-5.610E-04	-8.055E-01
1111	38.1	0.1	27.62	-1.016E-07	-5.610E-04	-8.055E-01
1112	37.4	(^e)	27.4	-1.016E-07	-5.610E-04	-8.055E-01
1113	36.1	(^e)	27.01	-1.016E-07	-5.610E-04	-8.055E-01
1114	35	(^e)	26.68	-1.016E-07	-5.610E-04	-8.055E-01
1115	34	(^e)	26.35	-1.016E-07	-5.610E-04	-8.055E-01
1116	32.7	(^e)	25.98	-1.016E-07	-5.610E-04	-8.055E-01
1117	31	(^e)	25.46	-1.016E-07	-5.610E-04	-8.055E-01
1118	29.8	0.8	25.05	-1.016E-07	-5.610E-04	-8.055E-01
1119	30	8.2	25.12	-1.016E-07	-5.610E-04	-8.055E-01
1120	29.8	1.2	25.07	-1.016E-07	-5.610E-04	-8.055E-01
1121	29.1	(^e)	24.86	-1.016E-07	-5.610E-04	-8.055E-01

1122	28	(^e)	24.51	-1.016E-07	-5.610E-04	-8.055E-01
1123	26.8	(^e)	24.15	-1.016E-07	-5.610E-04	-8.055E-01
1124	25.7	(^e)	23.82	-1.016E-07	-5.610E-04	-8.055E-01
1125	24	(^e)	23.3	-1.016E-07	-5.610E-04	-8.055E-01
1126	22.3	(^e)	22.79	-1.016E-07	-5.610E-04	-8.055E-01
1127	21.1	(^e)	22.39	-1.016E-07	-5.610E-04	-8.055E-01
1128	21	21.6	22.35	-1.016E-07	-5.610E-04	-8.055E-01
1129	22.6	36.9	22.82	-1.016E-07	-5.610E-04	-8.055E-01
1130	24.9	37.1	23.52	-1.016E-07	-5.610E-04	-8.055E-01
1131	26.9	30.8	24.15	-1.016E-07	-5.610E-04	-8.055E-01
1132	28.5	29.6	24.65	-1.016E-07	-5.610E-04	-8.055E-01
1133	29.8	23.4	25.04	-1.016E-07	-5.610E-04	-8.055E-01
1134	30.7	21.9	25.31	-1.016E-07	-5.610E-04	-8.055E-01
1135	31.8	20.3	25.65	-3.387E-08	-1.870E-04	-2.685E-01
1136	32.2	(^e)	25.81	3.387E-08	1.870E-04	2.685E-01
1137	30.6	(^e)	25.35	1.016E-07	5.610E-04	8.055E-01
1138	27.7	(^e)	24.45	1.016E-07	5.610E-04	8.055E-01
1139	24.8	(^e)	23.57	1.016E-07	5.610E-04	8.055E-01
1140	22.1	(^e)	22.73	1.016E-07	5.610E-04	8.055E-01
1141	20.1	(^e)	22.1	1.016E-07	5.610E-04	8.055E-01
1142	18.5	(^e)	21.62	1.016E-07	5.610E-04	8.055E-01
1143	21.2	11.1	20.87	1.016E-07	5.610E-04	8.055E-01
1144	36.3	(^e)	20.12	1.016E-07	5.610E-04	8.055E-01
1145	33.4	(^e)	19.46	1.016E-07	5.610E-04	8.055E-01
1146	30.7	(^e)	18.86	1.016E-07	5.610E-04	8.055E-01
1147	27.9	(^e)	18.21	1.016E-07	5.610E-04	8.055E-01
1148	24.4	(^e)	17.42	1.016E-07	5.610E-04	8.055E-01
1149	21.2	(^e)	16.68	1.016E-07	5.610E-04	8.055E-01
1150	17.9	(^e)	15.94	1.016E-07	5.610E-04	8.055E-01
1151	38.8	9.1	14.61	1.016E-07	5.610E-04	8.055E-01
1152	20.3	(^e)	12.21	1.016E-07	5.610E-04	8.055E-01
1153	15.9	12.7	8.78	1.016E-07	5.610E-04	8.055E-01
1154	12.6	(^e)	4.16	1.016E-07	5.610E-04	8.055E-01
1155	0	0	1.53	3.387E-08	1.870E-04	2.685E-01
1156	0	0	0.05	-3.387E-08	-1.870E-04	-2.685E-01
1157	0	0	0	-1.016E-07	-5.610E-04	-8.055E-01
1163	0	0	0	-1.016E-07	-5.610E-04	-8.055E-01
1164	0	0	0	1.960E-06	-2.704E-03	-3.877E-01
1165	2	7.7	0	4.021E-06	-4.848E-03	3.015E-02
1166	8.3	40.4	1.67	6.082E-06	-6.991E-03	4.480E-01
1167	34.3	17.6	3.22	6.082E-06	-6.991E-03	4.480E-01
1168	65.7	16.8	4.4	6.082E-06	-6.991E-03	4.480E-01
1169	35.6	5.8	4.25	6.082E-06	-6.991E-03	4.480E-01
1170	13.2	5.7	3.18	6.082E-06	-6.991E-03	4.480E-01
1171	0	0	2.29	6.082E-06	-6.991E-03	4.480E-01
1172	0	0	1.95	6.082E-06	-6.991E-03	4.480E-01
1173	57.3	38.8	4.02	6.082E-06	-6.991E-03	4.480E-01
1174	59.1	9.7	5.22	6.082E-06	-6.991E-03	4.480E-01
1175	63.4	29.7	5.81	6.082E-06	-6.991E-03	4.480E-01
1176	76	29.9	7.71	6.082E-06	-6.991E-03	4.480E-01
1177	24	4.9	6.89	6.082E-06	-6.991E-03	4.480E-01
1178	42.7	53.3	8.77	6.082E-06	-6.991E-03	4.480E-01
1179	81.2	36.8	12.38	6.082E-06	-6.991E-03	4.480E-01
1180	85.8	(^e)	12.88	6.082E-06	-6.991E-03	4.480E-01
1181	50.4	(^e)	12.56	6.082E-06	-6.991E-03	4.480E-01
1182	45.6	9.1	12.17	6.082E-06	-6.991E-03	4.480E-01
1183	57.4	46.7	13.57	6.082E-06	-6.991E-03	4.480E-01
1184	77.6	53.7	16.08	6.082E-06	-6.991E-03	4.480E-01
1185	89.2	19.2	17.59	6.082E-06	-6.991E-03	4.480E-01
1186	69.4	15.3	17.8	6.082E-06	-6.991E-03	4.480E-01
1187	56.2	36.1	18.12	6.082E-06	-6.991E-03	4.480E-01
1188	67.1	29.4	19.96	6.082E-06	-6.991E-03	4.480E-01
1189	72.5	36.6	20.86	6.082E-06	-6.991E-03	4.480E-01
1190	45.1	5.9	20.96	6.082E-06	-6.991E-03	4.480E-01
1191	41.1	43.2	21.15	6.082E-06	-6.991E-03	4.480E-01
1192	48.2	57.4	22.73	6.082E-06	-6.991E-03	4.480E-01

1193	53.6	36.3	24	6.082E-06	-6.991E-03	4.480E-01
1194	56.9	28.7	24.76	6.082E-06	-6.991E-03	4.480E-01
1195	58.6	15.2	25.16	6.082E-06	-6.991E-03	4.480E-01
1196	34	4.8	25.14	6.082E-06	-6.991E-03	4.480E-01
1197	28.5	(^e)	24.67	6.082E-06	-6.991E-03	4.480E-01
1198	28.6	16.6	24.68	6.082E-06	-6.991E-03	4.480E-01
1199	28.3	2.3	24.6	5.416E-06	-6.524E-03	4.641E-01
1200	29	25.8	24.79	4.750E-06	-6.058E-03	4.802E-01
1201	29.5	20.8	24.95	4.084E-06	-5.591E-03	4.963E-01
1202	30.3	31.8	25.18	4.084E-06	-5.591E-03	4.963E-01
1203	31.7	29.4	25.6	4.084E-06	-5.591E-03	4.963E-01
1204	32.7	26.6	25.94	4.084E-06	-5.591E-03	4.963E-01
1205	33.8	20.6	26.27	4.084E-06	-5.591E-03	4.963E-01
1206	34.1	14.2	26.38	4.084E-06	-5.591E-03	4.963E-01
1207	34.3	8.5	26.45	4.084E-06	-5.591E-03	4.963E-01
1208	34.2	7.6	26.41	4.084E-06	-5.591E-03	4.963E-01
1209	34.2	15.7	26.41	4.084E-06	-5.591E-03	4.963E-01
1210	34.9	17	26.6	4.084E-06	-5.591E-03	4.963E-01
1211	35.2	14.2	26.7	4.084E-06	-5.591E-03	4.963E-01
1212	35.2	13.2	26.7	4.084E-06	-5.591E-03	4.963E-01
1213	35.2	7.2	26.72	1.361E-06	-1.864E-03	1.654E-01
1214	34.9	(^e)	26.62	-1.361E-06	1.864E-03	-1.654E-01
1215	33.8	(^e)	26.32	-4.084E-06	5.591E-03	-4.963E-01
1216	31.6	(^e)	25.65	-4.084E-06	5.591E-03	-4.963E-01
1217	29.2	(^e)	24.9	-4.084E-06	5.591E-03	-4.963E-01
1218	26.7	(^e)	24.15	-4.084E-06	5.591E-03	-4.963E-01
1219	24.4	(^e)	23.44	-4.084E-06	5.591E-03	-4.963E-01
1220	22.1	(^e)	22.74	-4.084E-06	5.591E-03	-4.963E-01
1221	20	(^e)	22.07	-4.084E-06	5.591E-03	-4.963E-01
1222	17.8	(^e)	21.41	-4.084E-06	5.591E-03	-4.963E-01
1223	36.2	16.7	20.77	-4.084E-06	5.591E-03	-4.963E-01
1224	36.2	(^e)	20.11	-4.084E-06	5.591E-03	-4.963E-01
1225	32.5	(^e)	19.26	-4.084E-06	5.591E-03	-4.963E-01
1226	28.3	(^e)	18.3	-4.084E-06	5.591E-03	-4.963E-01
1227	22.2	(^e)	16.94	-4.084E-06	5.591E-03	-4.963E-01
1228	25.2	13.9	14.9	-4.084E-06	5.591E-03	-4.963E-01
1229	25.8	2	12.71	-4.084E-06	5.591E-03	-4.963E-01
1230	14.1	(^e)	11.12	-4.084E-06	5.591E-03	-4.963E-01
1231	10.6	7.4	10.12	-4.084E-06	5.591E-03	-4.963E-01
1232	20.8	0.2	8.74	-4.084E-06	5.591E-03	-4.963E-01
1233	12.3	(^e)	8.03	-4.084E-06	5.591E-03	-4.963E-01
1234	10.5	3.1	7.8	-4.084E-06	5.591E-03	-4.963E-01
1235	12.8	9.3	7.68	-4.084E-06	5.591E-03	-4.963E-01
1236	29.4	3.1	7.48	-1.361E-06	1.864E-03	-1.654E-01
1237	37.4	23.4	8.32	1.361E-06	-1.864E-03	1.654E-01
1238	53.5	32.7	9.8	4.084E-06	-5.591E-03	4.963E-01
1239	77.8	51.3	12.04	4.084E-06	-5.591E-03	4.963E-01
1240	80.8	31	13.87	4.084E-06	-5.591E-03	4.963E-01
1241	29.1	2.8	13.62	4.084E-06	-5.591E-03	4.963E-01
1242	38.6	63.7	15.13	4.084E-06	-5.591E-03	4.963E-01
1243	56.9	37.5	18.23	1.361E-06	-1.864E-03	1.654E-01
1244	58.8	(^e)	18.63	-1.361E-06	1.864E-03	-1.654E-01
1245	55.1	(^e)	18.02	-4.084E-06	5.591E-03	-4.963E-01
1246	51.3	(^e)	17.37	-4.084E-06	5.591E-03	-4.963E-01
1247	47.4	(^e)	16.71	-4.084E-06	5.591E-03	-4.963E-01
1248	43.4	(^e)	16.04	-4.084E-06	5.591E-03	-4.963E-01
1249	38.5	(^e)	15.23	-4.084E-06	5.591E-03	-4.963E-01
1250	30.4	(^e)	13.88	-4.084E-06	5.591E-03	-4.963E-01
1251	19.7	(^e)	12.09	-4.084E-06	5.591E-03	-4.963E-01
1252	11.8	(^e)	10.75	-4.084E-06	5.591E-03	-4.963E-01
1253	29.1	16.9	10.16	-1.361E-06	1.864E-03	-1.654E-01
1254	29.1	4.3	10.12	1.361E-06	-1.864E-03	1.654E-01
1255	34.4	24.4	10.75	4.084E-06	-5.591E-03	4.963E-01
1256	46.4	34.7	12.22	4.084E-06	-5.591E-03	4.963E-01
1257	61.2	45.4	14.05	4.084E-06	-5.591E-03	4.963E-01
1258	79.1	53.2	16.27	4.084E-06	-5.591E-03	4.963E-01

1259	95.4	38.8	17.96	4.084E-06	-5.591E-03	4.963E-01
1260	54.9	2.5	17.77	4.084E-06	-5.591E-03	4.963E-01
1261	56.1	5.8	18.16	4.084E-06	-5.591E-03	4.963E-01
1262	55.1	0.8	18	4.084E-06	-5.591E-03	4.963E-01
1263	53.7	0.4	17.76	4.084E-06	-5.591E-03	4.963E-01
1264	52.2	0.1	17.51	1.361E-06	-1.864E-03	1.654E-01
1265	51.4	4.3	17.37	-1.361E-06	1.864E-03	-1.654E-01
1266	48.8	(^e)	16.94	-4.084E-06	5.591E-03	-4.963E-01
1267	44.2	(^e)	16.19	-4.084E-06	5.591E-03	-4.963E-01
1268	35.3	(^e)	14.72	-4.084E-06	5.591E-03	-4.963E-01
1269	23.4	(^e)	12.72	-4.084E-06	5.591E-03	-4.963E-01
1270	11.3	(^e)	10.68	-4.084E-06	5.591E-03	-4.963E-01
1271	24.3	5.9	9.21	-4.084E-06	5.591E-03	-4.963E-01
1272	10.1	(^e)	7.77	-4.084E-06	5.591E-03	-4.963E-01
1273	20	1.1	6.54	-4.084E-06	5.591E-03	-4.963E-01
1274	17.9	11.7	4.66	-4.084E-06	5.591E-03	-4.963E-01
1275	6.3	0.7	2.8	-1.361E-06	1.864E-03	-1.654E-01
1276	9.6	23.3	3.12	1.361E-06	-1.864E-03	1.654E-01
1277	33.1	16.3	4.31	4.084E-06	-5.591E-03	4.963E-01
1278	58.7	18.9	5.6	4.084E-06	-5.591E-03	4.963E-01
1279	87.6	26.5	6.99	4.084E-06	-5.591E-03	4.963E-01
1280	48.5	1.8	6.84	4.084E-06	-5.591E-03	4.963E-01
1281	74.4	41.3	8.63	4.084E-06	-5.591E-03	4.963E-01
1282	64.1	12.5	9.83	4.084E-06	-5.591E-03	4.963E-01
1283	57.1	34.6	10.14	4.084E-06	-5.591E-03	4.963E-01
1284	91	78.4	13.22	4.084E-06	-5.591E-03	4.963E-01
1285	38.6	8.5	13.95	4.084E-06	-5.591E-03	4.963E-01
1286	32.8	40	14.2	4.084E-06	-5.591E-03	4.963E-01
1287	47	74.3	16.52	4.084E-06	-5.591E-03	4.963E-01
1288	64.2	53.9	19.43	4.084E-06	-5.591E-03	4.963E-01
1289	70.4	21.4	20.54	4.084E-06	-5.591E-03	4.963E-01
1290	71.9	7.4	20.81	4.084E-06	-5.591E-03	4.963E-01
1291	39.8	2.4	20.61	4.084E-06	-5.591E-03	4.963E-01
1292	39.6	32	20.81	4.084E-06	-5.591E-03	4.963E-01
1293	42.7	24	21.52	4.084E-06	-5.591E-03	4.963E-01
1294	44.6	20.6	21.98	4.084E-06	-5.591E-03	4.963E-01
1295	47.3	31.6	22.58	4.084E-06	-5.591E-03	4.963E-01
1296	49.9	22.2	23.18	4.084E-06	-5.591E-03	4.963E-01
1297	50.7	9.1	23.38	4.084E-06	-5.591E-03	4.963E-01
1298	50.1	0.8	23.24	4.084E-06	-5.591E-03	4.963E-01
1299	49.4	4.5	23.08	4.084E-06	-5.591E-03	4.963E-01
1300	48	(^e)	22.79	1.361E-06	-1.864E-03	1.654E-01
1301	46.9	1.9	22.53	-1.361E-06	1.864E-03	-1.654E-01
1302	45.9	0	22.29	-4.084E-06	5.591E-03	-4.963E-01
1303	44.2	(^e)	21.93	-4.084E-06	5.591E-03	-4.963E-01
1304	42.2	(^e)	21.47	-4.084E-06	5.591E-03	-4.963E-01
1305	39.1	(^e)	20.77	-4.084E-06	5.591E-03	-4.963E-01
1306	33.2	(^e)	19.45	-4.084E-06	5.591E-03	-4.963E-01
1307	25.5	(^e)	17.72	-4.084E-06	5.591E-03	-4.963E-01
1308	16	3.5	15.24	-4.084E-06	5.591E-03	-4.963E-01
1309	27.1	(^e)	12.8	-4.084E-06	5.591E-03	-4.963E-01
1310	8.7	(^e)	10.26	-4.084E-06	5.591E-03	-4.963E-01
1311	11.4	5.9	7.19	-4.084E-06	5.591E-03	-4.963E-01
1312	13.8	6.7	5.46	-4.084E-06	5.591E-03	-4.963E-01
1313	14.3	(^e)	4.52	-4.084E-06	5.591E-03	-4.963E-01
1314	30	14.9	4.17	-1.361E-06	1.864E-03	-1.654E-01
1315	27.8	0.3	4.06	1.361E-06	-1.864E-03	1.654E-01
1316	41.8	16.8	4.74	4.084E-06	-5.591E-03	4.963E-01
1317	68.8	20.7	6.11	4.084E-06	-5.591E-03	4.963E-01
1318	65.3	16.6	6.88	4.084E-06	-5.591E-03	4.963E-01
1319	50.9	30.1	7.04	4.084E-06	-5.591E-03	4.963E-01
1320	71.4	14.2	8.48	4.084E-06	-5.591E-03	4.963E-01
1321	65.7	16.8	8.79	4.084E-06	-5.591E-03	4.963E-01
1322	41.5	12.7	8.72	4.084E-06	-5.591E-03	4.963E-01
1323	45.3	9	9.08	1.361E-06	-1.864E-03	1.654E-01
1324	47	(^e)	9.26	-1.361E-06	1.864E-03	-1.654E-01

1325	41.1	(°)	8.71	-4.084E-06	5.591E-03	-4.963E-01
1326	34.1	(°)	8.06	-4.084E-06	5.591E-03	-4.963E-01
1327	23.5	(°)	7.08	-4.084E-06	5.591E-03	-4.963E-01
1328	8.1	1.2	5.51	-4.084E-06	5.591E-03	-4.963E-01
1329	19.1	9.4	3.49	-4.084E-06	5.591E-03	-4.963E-01
1330	0	0	2.56	-4.084E-06	5.591E-03	-4.963E-01
1331	0.9	7.7	2.34	-1.361E-06	1.864E-03	-1.654E-01
1332	0.7	3.4	2.53	1.361E-06	-1.864E-03	1.654E-01
1333	0	0	2.45	4.084E-06	-5.591E-03	4.963E-01
1334	7.5	17.5	3.02	4.084E-06	-5.591E-03	4.963E-01
1335	22.4	12	3.77	4.084E-06	-5.591E-03	4.963E-01
1336	36	10.8	4.46	4.084E-06	-5.591E-03	4.963E-01
1337	48.2	6.5	5.09	1.361E-06	-1.864E-03	1.654E-01
1338	48	0.2	5.09	-1.361E-06	1.864E-03	-1.654E-01
1339	39.2	(°)	4.65	-4.084E-06	5.591E-03	-4.963E-01
1340	27.4	(°)	4.05	-4.084E-06	5.591E-03	-4.963E-01
1341	15.9	(°)	3.46	-4.084E-06	5.591E-03	-4.963E-01
1342	2	0.2	2.89	-4.084E-06	5.591E-03	-4.963E-01
1343	0.1	3.8	1.88	-4.084E-06	5.591E-03	-4.963E-01
1344	0	0	1.24	-4.084E-06	5.591E-03	-4.963E-01
1345	0	0	0	-4.084E-06	5.591E-03	-4.963E-01
1349	0	0	0	-4.084E-06	5.591E-03	-4.963E-01
1350	0	0	0	2.872E-07	7.170E-04	1.226E-01
1351	0	0	0	4.658E-06	-4.157E-03	7.415E-01
1352	1.1	6.8	0.02	9.029E-06	-9.032E-03	1.360E+00
1353	6.1	21.6	0.65	9.029E-06	-9.032E-03	1.360E+00
1354	6.4	18.5	1.96	9.029E-06	-9.032E-03	1.360E+00
1355	17.4	10.1	2.61	9.029E-06	-9.032E-03	1.360E+00
1356	30.9	7.8	3.11	9.029E-06	-9.032E-03	1.360E+00
1357	44.5	8.4	3.62	9.029E-06	-9.032E-03	1.360E+00
1358	61.1	10.5	4.24	9.029E-06	-9.032E-03	1.360E+00
1359	35.1	0.4	4.33	9.029E-06	-9.032E-03	1.360E+00
1360	52.5	23.7	5.27	9.029E-06	-9.032E-03	1.360E+00
1361	83.5	20.9	6.86	9.029E-06	-9.032E-03	1.360E+00
1362	50.3	0.8	6.89	9.029E-06	-9.032E-03	1.360E+00
1363	68	37.5	8.2	9.029E-06	-9.032E-03	1.360E+00
1364	85.5	25.2	9.88	9.029E-06	-9.032E-03	1.360E+00
1365	52.7	8.2	9.77	9.029E-06	-9.032E-03	1.360E+00
1366	73.4	39.6	11.65	9.029E-06	-9.032E-03	1.360E+00
1367	89.5	27.4	13.24	9.029E-06	-9.032E-03	1.360E+00
1368	53	6	13.1	9.029E-06	-9.032E-03	1.360E+00
1369	63.6	11.9	14.41	9.029E-06	-9.032E-03	1.360E+00
1370	65.6	12.2	14.65	7.296E-06	-7.440E-03	1.057E+00
1371	37.4	1	14.67	5.562E-06	-5.849E-03	7.534E-01
1372	38.7	40	15.19	3.829E-06	-4.257E-03	4.499E-01
1373	45.5	24.5	16.35	3.829E-06	-4.257E-03	4.499E-01
1374	49	17.2	16.95	3.829E-06	-4.257E-03	4.499E-01
1375	51.4	13.6	17.35	3.829E-06	-4.257E-03	4.499E-01
1376	52.5	7.2	17.56	3.829E-06	-4.257E-03	4.499E-01
1377	51.4	(°)	17.38	3.829E-06	-4.257E-03	4.499E-01
1378	48.9	(°)	16.96	3.829E-06	-4.257E-03	4.499E-01
1379	45.8	(°)	16.44	3.829E-06	-4.257E-03	4.499E-01
1380	42.4	(°)	15.88	3.829E-06	-4.257E-03	4.499E-01
1381	38.5	(°)	15.23	3.829E-06	-4.257E-03	4.499E-01
1382	38.6	11.6	15.22	3.829E-06	-4.257E-03	4.499E-01
1383	39.9	6.5	15.44	1.276E-06	-1.419E-03	1.500E-01
1384	39.3	2	15.34	-1.276E-06	1.419E-03	-1.500E-01
1385	37.9	(°)	15.12	-3.829E-06	4.257E-03	-4.499E-01
1386	35.1	(°)	14.65	-3.829E-06	4.257E-03	-4.499E-01
1387	32.2	(°)	14.16	-3.829E-06	4.257E-03	-4.499E-01
1388	27.3	(°)	13.35	-3.829E-06	4.257E-03	-4.499E-01
1389	18.7	(°)	11.92	-3.829E-06	4.257E-03	-4.499E-01
1390	10.4	8.1	9.91	-3.829E-06	4.257E-03	-4.499E-01
1391	14.8	4.6	7.88	-3.829E-06	4.257E-03	-4.499E-01
1392	13.2	3.6	5.88	-3.829E-06	4.257E-03	-4.499E-01
1393	13.6	8.9	3.69	-3.829E-06	4.257E-03	-4.499E-01

1394	0	0	2.44	-5.773E-06	6.214E-03	-9.832E-01
1395	0	0	2.26	-7.717E-06	8.171E-03	-1.516E+00
1396	0.5	9.5	2.01	-3.221E-06	3.376E-03	-6.833E-01
1397	5.4	7.1	1.94	3.221E-06	-3.376E-03	6.833E-01
1398	8.2	9	2.27	9.662E-06	-1.013E-02	2.050E+00
1399	21.2	10.3	2.74	9.662E-06	-1.013E-02	2.050E+00
1400	43.7	13.1	3.58	9.662E-06	-1.013E-02	2.050E+00
1401	68.2	16.2	4.51	9.662E-06	-1.013E-02	2.050E+00
1402	35.2	2	4.36	9.662E-06	-1.013E-02	2.050E+00
1403	67.5	31.5	6.02	9.662E-06	-1.013E-02	2.050E+00
1404	78.2	22.2	7.27	9.662E-06	-1.013E-02	2.050E+00
1405	54	18.5	7.27	9.662E-06	-1.013E-02	2.050E+00
1406	89.3	35.3	9.67	9.662E-06	-1.013E-02	2.050E+00
1407	54.6	0.9	9.76	9.662E-06	-1.013E-02	2.050E+00
1408	64.4	29.5	10.83	9.662E-06	-1.013E-02	2.050E+00
1409	77.2	23.7	12.04	9.662E-06	-1.013E-02	2.050E+00
1410	49	2.1	12.27	9.662E-06	-1.013E-02	2.050E+00
1411	52.1	40.4	12.93	9.662E-06	-1.013E-02	2.050E+00
1412	63.3	18.4	14.36	9.662E-06	-1.013E-02	2.050E+00
1413	62.3	(^e)	14.27	9.662E-06	-1.013E-02	2.050E+00
1414	29.7	(^e)	13.64	9.662E-06	-1.013E-02	2.050E+00
1415	24.2	(^e)	12.82	9.662E-06	-1.013E-02	2.050E+00
1416	18.8	(^e)	11.92	9.662E-06	-1.013E-02	2.050E+00
1417	14.1	(^e)	11.12	9.662E-06	-1.013E-02	2.050E+00
1418	10.5	(^e)	10.5	8.531E-06	-9.269E-03	1.714E+00
1419	11.3	25.6	10.63	7.400E-06	-8.410E-03	1.379E+00
1420	14.9	15.2	11.24	6.269E-06	-7.552E-03	1.044E+00
1421	12.8	(^e)	10.9	6.269E-06	-7.552E-03	1.044E+00
1422	25	9.3	9.25	6.269E-06	-7.552E-03	1.044E+00
1423	18.6	9.1	8.81	6.269E-06	-7.552E-03	1.044E+00
1424	24.5	24.4	9.52	6.269E-06	-7.552E-03	1.044E+00
1425	32.7	24.2	10.54	6.269E-06	-7.552E-03	1.044E+00
1426	41.1	24.4	11.59	6.269E-06	-7.552E-03	1.044E+00
1427	50	26	12.69	6.269E-06	-7.552E-03	1.044E+00
1428	58.6	18.7	13.77	6.269E-06	-7.552E-03	1.044E+00
1429	64	25.5	14.44	6.269E-06	-7.552E-03	1.044E+00
1430	37.7	1.4	14.67	6.269E-06	-7.552E-03	1.044E+00
1431	38.4	30.5	15.15	2.090E-06	-2.517E-03	3.478E-01
1432	39.3	(^e)	15.34	-2.090E-06	2.517E-03	-3.478E-01
1433	36.4	(^e)	14.86	-6.269E-06	7.552E-03	-1.044E+00
1434	33.4	(^e)	14.36	-6.269E-06	7.552E-03	-1.044E+00
1435	29.7	(^e)	13.74	-6.269E-06	7.552E-03	-1.044E+00
1436	25.8	(^e)	13.08	-6.269E-06	7.552E-03	-1.044E+00
1437	21.3	(^e)	12.34	-6.269E-06	7.552E-03	-1.044E+00
1438	17.5	(^e)	11.69	-6.269E-06	7.552E-03	-1.044E+00
1439	15.1	1.2	11.28	-6.269E-06	7.552E-03	-1.044E+00
1440	14.3	2.3	11.14	-6.269E-06	7.552E-03	-1.044E+00
1441	12.6	(^e)	10.86	-6.269E-06	7.552E-03	-1.044E+00
1442	9.9	(^e)	10.42	-6.269E-06	7.552E-03	-1.044E+00
1443	27.4	13.6	9.89	-6.269E-06	7.552E-03	-1.044E+00
1444	23	(^e)	9.37	-6.269E-06	7.552E-03	-1.044E+00
1445	20.8	3.5	9.09	-6.269E-06	7.552E-03	-1.044E+00
1446	20.5	5.3	9.05	-6.269E-06	7.552E-03	-1.044E+00
1447	18.5	(^e)	8.8	-6.269E-06	7.552E-03	-1.044E+00
1448	11.9	(^e)	8	-6.269E-06	7.552E-03	-1.044E+00
1449	22.4	6.1	6.71	-6.269E-06	7.552E-03	-1.044E+00
1450	10	8.7	5.21	-6.269E-06	7.552E-03	-1.044E+00
1451	6.7	0.6	2.72	-6.269E-06	7.552E-03	-1.044E+00
1452	0	0	0.95	-6.269E-06	7.552E-03	-1.044E+00
1453	0	0	0	-6.269E-06	7.552E-03	-1.044E+00
1454	0	0	0	-6.269E-06	7.552E-03	-1.044E+00
1455	0	0	0	-1.593E-06	2.190E-03	-8.036E-01
1456	0	0	0	3.083E-06	-3.171E-03	-5.636E-01
1457	0	0	0	7.759E-06	-8.533E-03	-3.236E-01
1518	0	0	0	7.759E-06	-8.533E-03	-3.236E-01
1519	5.1	15	0.14	7.759E-06	-8.533E-03	-3.236E-01

1520	7	25.8	1.71	7.759E-06	-8.533E-03	-3.236E-01
1521	18.1	9.5	2.64	7.759E-06	-8.533E-03	-3.236E-01
1522	28.4	7.1	3.02	7.759E-06	-8.533E-03	-3.236E-01
1523	44.9	9.8	3.64	7.759E-06	-8.533E-03	-3.236E-01
1524	57.8	6.7	4.13	7.759E-06	-8.533E-03	-3.236E-01
1525	33.6	4.5	4.17	7.759E-06	-8.533E-03	-3.236E-01
1526	37.9	12.1	4.56	7.759E-06	-8.533E-03	-3.236E-01
1527	48.5	6.2	5.11	2.586E-06	-2.844E-03	-1.079E-01
1528	49.9	1.3	5.19	-2.586E-06	2.844E-03	1.079E-01
1529	42.5	(°)	4.82	-7.759E-06	8.533E-03	3.236E-01
1530	30.4	(°)	4.2	-7.759E-06	8.533E-03	3.236E-01
1531	18.7	(°)	3.61	-7.759E-06	8.533E-03	3.236E-01
1532	4	0.9	2.85	-7.759E-06	8.533E-03	3.236E-01
1533	0.1	3.9	1.94	-7.759E-06	8.533E-03	3.236E-01
1534	0	0	1.16	-2.586E-06	2.844E-03	1.079E-01
1535	0	0	0	2.586E-06	-2.844E-03	-1.079E-01
1536	0	0	0	7.759E-06	-8.533E-03	-3.236E-01
1560	0	0	0	7.759E-06	-8.533E-03	-3.236E-01
1561	3	5	0	7.759E-06	-8.533E-03	-3.236E-01
1562	7	10	0	7.759E-06	-8.533E-03	-3.236E-01
1563	4.7	8.1	0.62	7.759E-06	-8.533E-03	-3.236E-01
1564	2	6.4	1.04	7.759E-06	-8.533E-03	-3.236E-01
1565	6.2	11.6	1.54	7.759E-06	-8.533E-03	-3.236E-01
1566	8.6	8.9	2.49	7.759E-06	-8.533E-03	-3.236E-01
1567	20.7	5.2	2.98	7.759E-06	-8.533E-03	-3.236E-01
1568	28	1.9	3.28	2.586E-06	-2.844E-03	-1.079E-01
1569	25.6	(°)	3.19	-2.586E-06	2.844E-03	1.079E-01
1570	14.9	(°)	2.75	-7.759E-06	8.533E-03	3.236E-01
1571	0	0	1.3	-2.586E-06	2.844E-03	1.079E-01
1572	0	0	0	2.586E-06	-2.844E-03	-1.079E-01
1573	1.2	6.5	0.05	7.759E-06	-8.533E-03	-3.236E-01
1574	6.8	23.2	1.12	7.759E-06	-8.533E-03	-3.236E-01
1575	16.6	14.1	2.81	7.759E-06	-8.533E-03	-3.236E-01
1576	52.5	14.5	4.24	7.759E-06	-8.533E-03	-3.236E-01
1577	76.9	22.6	5.6	7.759E-06	-8.533E-03	-3.236E-01
1578	52.1	12.3	5.96	7.759E-06	-8.533E-03	-3.236E-01
1579	94.5	27.6	8.32	7.759E-06	-8.533E-03	-3.236E-01
1580	56.4	1	8.63	7.759E-06	-8.533E-03	-3.236E-01
1581	66	5.3	9.37	2.586E-06	-2.844E-03	-1.079E-01
1582	49.2	6.7	9.62	-2.586E-06	2.844E-03	1.079E-01
1583	31.3	(°)	9.11	-7.759E-06	8.533E-03	3.236E-01
1584	22.1	(°)	8.11	-7.759E-06	8.533E-03	3.236E-01
1585	12.1	(°)	7.01	-7.759E-06	8.533E-03	3.236E-01
1586	27.3	8.2	6.04	-7.759E-06	8.533E-03	3.236E-01
1587	16	(°)	5.42	-2.586E-06	2.844E-03	1.079E-01
1588	17.4	10.5	5.5	2.586E-06	-2.844E-03	-1.079E-01
1589	33.7	15.4	6.79	7.759E-06	-8.533E-03	-3.236E-01
1590	43.6	(°)	7.61	7.759E-06	-8.533E-03	-3.236E-01
1591	37.7	(°)	7.15	7.759E-06	-8.533E-03	-3.236E-01
1592	34.8	6.5	6.89	7.759E-06	-8.533E-03	-3.236E-01
1593	60.7	30.4	8.88	7.759E-06	-8.533E-03	-3.236E-01
1594	90.6	21.4	11.28	7.759E-06	-8.533E-03	-3.236E-01
1595	54.9	(°)	11.48	7.759E-06	-8.533E-03	-3.236E-01
1596	48.4	(°)	10.97	7.759E-06	-8.533E-03	-3.236E-01
1597	56.5	19.6	11.78	7.759E-06	-8.533E-03	-3.236E-01
1598	72	21.8	13.47	7.759E-06	-8.533E-03	-3.236E-01
1599	85.8	26.9	14.92	7.759E-06	-8.533E-03	-3.236E-01
1600	32.2	2.2	15.21	7.759E-06	-8.533E-03	-3.236E-01
1601	42.2	31.8	17.03	7.759E-06	-8.533E-03	-3.236E-01
1602	46.5	1.9	17.89	7.759E-06	-8.533E-03	-3.236E-01
1603	57.8	21.7	19.09	2.586E-06	-2.844E-03	-1.079E-01
1604	37.1	4.8	19.37	-2.586E-06	2.844E-03	1.079E-01
1605	36.7	(°)	19.31	-7.759E-06	8.533E-03	3.236E-01
1606	32.8	(°)	18.5	-7.759E-06	8.533E-03	3.236E-01
1607	27.8	(°)	17.4	-7.759E-06	8.533E-03	3.236E-01
1608	22.8	(°)	16.33	-7.759E-06	8.533E-03	3.236E-01

1609	16.5	(°)	14.97	-7.759E-06	8.533E-03	3.236E-01
1610	10.3	7.6	12.74	-7.759E-06	8.533E-03	3.236E-01
1611	12.8	6.4	10.27	-7.759E-06	8.533E-03	3.236E-01
1612	30.4	11.4	8.67	-7.759E-06	8.533E-03	3.236E-01
1613	12.4	(°)	7.07	-7.992E-06	8.661E-03	1.236E+00
1614	0	0	4.45	-8.224E-06	8.788E-03	2.148E+00
1615	1.1	1.4	3.71	-2.819E-06	2.972E-03	1.020E+00
1616	43.1	4.2	5.47	2.819E-06	-2.972E-03	-1.020E+00
1617	54.9	6.5	6.15	8.457E-06	-8.916E-03	-3.061E+00
1618	74.6	17.4	7.24	8.457E-06	-8.916E-03	-3.061E+00
1619	52.3	1.4	8.08	8.457E-06	-8.916E-03	-3.061E+00
1620	67.1	23.5	9.41	8.457E-06	-8.916E-03	-3.061E+00
1621	79.1	1.9	10.43	2.819E-06	-2.972E-03	-1.020E+00
1622	46.4	(°)	10.52	-2.819E-06	2.972E-03	1.020E+00
1623	39	(°)	9.95	-8.457E-06	8.916E-03	3.061E+00
1624	28.8	(°)	8.85	-8.457E-06	8.916E-03	3.061E+00
1625	16.6	(°)	7.52	-8.457E-06	8.916E-03	3.061E+00
1626	20.1	14.2	6.17	-8.457E-06	8.916E-03	3.061E+00
1627	15.4	(°)	5.37	-2.819E-06	2.972E-03	1.020E+00
1628	17.1	10.6	5.48	2.819E-06	-2.972E-03	-1.020E+00
1629	40.8	26.5	7.31	8.457E-06	-8.916E-03	-3.061E+00
1630	69.8	18.3	9.64	8.457E-06	-8.916E-03	-3.061E+00
1631	85.7	13.1	10.91	8.457E-06	-8.916E-03	-3.061E+00
1632	51.9	1.7	11.25	8.457E-06	-8.916E-03	-3.061E+00
1633	72.1	42.7	13.42	8.457E-06	-8.916E-03	-3.061E+00
1634	84.4	29.2	15.77	8.457E-06	-8.916E-03	-3.061E+00
1635	35.6	(°)	15.91	8.457E-06	-8.916E-03	-3.061E+00
1636	40.5	30.3	16.73	8.457E-06	-8.916E-03	-3.061E+00
1637	52.7	44.5	18.91	8.457E-06	-8.916E-03	-3.061E+00
1638	65.4	19.1	21.27	2.819E-06	-2.972E-03	-1.020E+00
1639	67.1	(°)	21.64	-2.819E-06	2.972E-03	1.020E+00
1640	34	(°)	21.56	-8.457E-06	8.916E-03	3.061E+00
1641	31.3	(°)	21.28	-8.457E-06	8.916E-03	3.061E+00
1642	29.3	(°)	20.79	-8.457E-06	8.916E-03	3.061E+00
1643	25.4	(°)	19.83	-8.457E-06	8.916E-03	3.061E+00
1644	19.9	(°)	18.43	-8.457E-06	8.916E-03	3.061E+00
1645	23	5.7	16.06	-8.457E-06	8.916E-03	3.061E+00
1646	8.9	5.7	12.52	-8.457E-06	8.916E-03	3.061E+00
1647	12.4	7.5	8.98	-8.457E-06	8.916E-03	3.061E+00
1648	16.5	2.7	7.22	-8.457E-06	8.916E-03	3.061E+00
1649	25	10.8	5.92	-8.457E-06	8.916E-03	3.061E+00
1650	16.3	4.1	5.43	-2.819E-06	2.972E-03	1.020E+00
1651	41.5	28.9	7.37	2.819E-06	-2.972E-03	-1.020E+00
1652	82.3	43.6	10.55	8.457E-06	-8.916E-03	-3.061E+00
1653	56.9	0.2	11.66	8.457E-06	-8.916E-03	-3.061E+00
1654	70.1	45.2	13.2	8.457E-06	-8.916E-03	-3.061E+00
1655	72.7	29.1	15.78	8.457E-06	-8.916E-03	-3.061E+00
1656	36.9	16.9	16.11	8.457E-06	-8.916E-03	-3.061E+00
1657	42.7	(°)	17.2	2.819E-06	-2.972E-03	-1.020E+00
1658	41.3	(°)	16.96	-2.819E-06	2.972E-03	1.020E+00
1659	37.7	(°)	16.32	-8.457E-06	8.916E-03	3.061E+00
1660	34.5	(°)	15.73	-8.457E-06	8.916E-03	3.061E+00
1661	27	(°)	14.41	-8.457E-06	8.916E-03	3.061E+00
1662	15	(°)	12.23	-8.457E-06	8.916E-03	3.061E+00
1663	11.6	0.1	9.56	-8.457E-06	8.916E-03	3.061E+00
1664	10	(°)	6.48	-8.457E-06	8.916E-03	3.061E+00
1665	15.6	9.8	3.7	-8.457E-06	8.916E-03	3.061E+00
1666	0	0	0.19	-8.457E-06	8.916E-03	3.061E+00
1667	0	0	0	-8.457E-06	8.916E-03	3.061E+00
1668	0	0	0	1.191E-06	-1.811E-04	2.220E+00
1669	0	0	0	1.084E-05	-9.278E-03	1.379E+00
1670	0	0	0	2.049E-05	-1.837E-02	5.378E-01
1678	0	0	0	2.049E-05	-1.837E-02	5.378E-01
1679	1.4	7.2	0.05	2.049E-05	-1.837E-02	5.378E-01
1680	6.6	22.6	0.85	2.049E-05	-1.837E-02	5.378E-01
1681	16.2	15.4	2.8	2.049E-05	-1.837E-02	5.378E-01

1682	59.1	19.5	4.49	2.049E-05	-1.837E-02	5.378E-01
1683	67.4	17.1	5.91	2.049E-05	-1.837E-02	5.378E-01
1684	62.3	17.7	6.54	2.049E-05	-1.837E-02	5.378E-01
1685	77.8	11.5	7.55	2.049E-05	-1.837E-02	5.378E-01
1686	41.8	(°)	7.48	2.049E-05	-1.837E-02	5.378E-01
1687	35.9	(°)	7	2.049E-05	-1.837E-02	5.378E-01
1688	39.3	0.2	7.27	6.829E-06	-6.125E-03	1.793E-01
1689	34.3	(°)	6.88	-6.829E-06	6.125E-03	-1.793E-01
1690	9.5	3.5	4.95	-6.829E-06	6.125E-03	-1.793E-01
1691	0	0	0	6.829E-06	-6.125E-03	1.793E-01
1692	0	0	0	2.049E-05	-1.837E-02	5.378E-01
1693	0	0	0	2.049E-05	-1.837E-02	5.378E-01
1694	0.5	6.5	0.15	2.049E-05	-1.837E-02	5.378E-01
1695	3.6	6.9	0.57	2.049E-05	-1.837E-02	5.378E-01
1696	5.4	9.3	1.14	2.049E-05	-1.837E-02	5.378E-01
1697	5.5	6.2	1.71	2.049E-05	-1.837E-02	5.378E-01
1698	3.1	3.5	2.03	2.049E-05	-1.837E-02	5.378E-01
1699	0	0	2.12	2.049E-05	-1.837E-02	5.378E-01
1700	0	0	1.59	2.049E-05	-1.837E-02	5.378E-01
1701	0	0	0	2.049E-05	-1.837E-02	5.378E-01
1702	3.1	7.4	0.27	2.049E-05	-1.837E-02	5.378E-01
1703	6.8	20.3	1.79	2.049E-05	-1.837E-02	5.378E-01
1704	24.6	12.8	3.14	2.049E-05	-1.837E-02	5.378E-01
1705	64.5	18.2	4.72	2.049E-05	-1.837E-02	5.378E-01
1706	53.8	7.7	5.69	2.049E-05	-1.837E-02	5.378E-01
1707	66.6	27.9	6.75	2.049E-05	-1.837E-02	5.378E-01
1708	72.2	18.5	8.42	2.049E-05	-1.837E-02	5.378E-01
1709	63.5	31.1	9.1	2.049E-05	-1.837E-02	5.378E-01
1710	94.7	29.7	11.46	2.049E-05	-1.837E-02	5.378E-01
1711	55.9	2.1	11.77	2.049E-05	-1.837E-02	5.378E-01
1712	82.9	60.8	14.55	2.049E-05	-1.837E-02	5.378E-01
1713	39.6	4.9	15.87	6.829E-06	-6.125E-03	1.793E-01
1714	38.7	4.2	16.46	-6.829E-06	6.125E-03	-1.793E-01
1715	37.4	(°)	16.26	-2.049E-05	1.837E-02	-5.378E-01
1716	32.9	(°)	15.46	-2.049E-05	1.837E-02	-5.378E-01
1717	27.7	(°)	14.51	-2.049E-05	1.837E-02	-5.378E-01
1718	23.1	(°)	13.67	-2.049E-05	1.837E-02	-5.378E-01
1719	17.1	(°)	12.6	-2.049E-05	1.837E-02	-5.378E-01
1720	9.1	6.4	10.02	-1.891E-05	1.685E-02	4.276E-01
1721	10.6	3	6.37	-6.829E-06	6.125E-03	-1.793E-01
1722	37.5	15.4	7.09	5.248E-06	-4.601E-03	-7.862E-01
1723	73.5	38.4	9.87	1.574E-05	-1.380E-02	-2.358E+00
1724	87.7	20.1	11.51	1.574E-05	-1.380E-02	-2.358E+00
1725	56.6	5.6	11.83	1.574E-05	-1.380E-02	-2.358E+00
1726	85.3	41.3	14.86	1.574E-05	-1.380E-02	-2.358E+00
1727	41.9	7.1	15.88	1.574E-05	-1.380E-02	-2.358E+00
1728	40.7	38.8	16.75	1.574E-05	-1.380E-02	-2.358E+00
1729	51.4	13	18.75	1.574E-05	-1.380E-02	-2.358E+00
1730	51.6	(°)	18.82	1.574E-05	-1.380E-02	-2.358E+00
1731	33.9	(°)	18.77	1.574E-05	-1.380E-02	-2.358E+00
1732	34	(°)	18.71	1.574E-05	-1.380E-02	-2.358E+00
1733	35	1.8	18.92	1.574E-05	-1.380E-02	-2.358E+00
1734	35.6	(°)	19.07	5.248E-06	-4.601E-03	-7.862E-01
1735	33.9	(°)	18.71	-5.248E-06	4.601E-03	7.862E-01
1736	30.3	(°)	17.95	-1.574E-05	1.380E-02	2.358E+00
1737	25.8	(°)	16.97	-1.574E-05	1.380E-02	2.358E+00
1738	21	(°)	15.93	-1.574E-05	1.380E-02	2.358E+00
1739	16.3	(°)	14.9	-1.574E-05	1.380E-02	2.358E+00
1740	11.5	(°)	13.86	-1.574E-05	1.380E-02	2.358E+00
1741	18.5	5.5	12.45	-1.722E-05	1.520E-02	1.428E+00
1742	12.4	8.2	10.28	-1.870E-05	1.660E-02	4.983E-01
1743	24.2	7.3	7.92	-2.018E-05	1.800E-02	-4.318E-01
1744	17	6.9	5.23	-2.018E-05	1.800E-02	-4.318E-01
1745	21.2	11.5	4.36	-6.726E-06	6.000E-03	-1.439E-01
1746	52.4	26	5.94	6.726E-06	-6.000E-03	1.439E-01
1747	89.6	29.8	8.35	2.018E-05	-1.800E-02	4.318E-01

1748	57.8	11.2	8.7	2.018E-05	-1.800E-02	4.318E-01
1749	97.7	41.2	11.46	2.018E-05	-1.800E-02	4.318E-01
1750	55.9	(^e)	11.77	2.018E-05	-1.800E-02	4.318E-01
1751	80.7	31.1	14.39	2.018E-05	-1.800E-02	4.318E-01
1752	71.6	28.9	15.8	2.018E-05	-1.800E-02	4.318E-01
1753	37	17	16.13	2.018E-05	-1.800E-02	4.318E-01
1754	41.1	7.7	16.88	2.018E-05	-1.800E-02	4.318E-01
1755	44.3	7.3	17.47	2.018E-05	-1.800E-02	4.318E-01
1756	46.7	(^e)	17.93	2.018E-05	-1.800E-02	4.318E-01
1757	30.6	(^e)	17.61	2.018E-05	-1.800E-02	4.318E-01
1758	24.8	(^e)	16.74	2.018E-05	-1.800E-02	4.318E-01
1759	21.2	(^e)	15.93	2.018E-05	-1.800E-02	4.318E-01
1760	21.2	4.1	15.91	2.018E-05	-1.800E-02	4.318E-01
1761	23.4	2.4	16.39	6.726E-06	-6.000E-03	1.439E-01
1762	23.4	(^e)	16.42	-6.726E-06	6.000E-03	-1.439E-01
1763	19.7	(^e)	15.63	-2.018E-05	1.800E-02	-4.318E-01
1764	13.8	(^e)	14.36	-2.018E-05	1.800E-02	-4.318E-01
1765	12.6	9.7	12.98	-2.018E-05	1.800E-02	-4.318E-01
1766	12.5	(^e)	11.75	-2.018E-05	1.800E-02	-4.318E-01
1767	15.5	10.3	10.96	-2.018E-05	1.800E-02	-4.318E-01
1768	12.4	(^e)	9.99	-2.018E-05	1.800E-02	-4.318E-01
1769	23.1	7.5	7.76	-2.018E-05	1.800E-02	-4.318E-01
1770	20.1	7.4	5.51	-2.018E-05	1.800E-02	-4.318E-01
1771	17.8	5.9	3.84	-6.726E-06	6.000E-03	-1.439E-01
1772	0	0	2.83	-3.978E-06	4.119E-04	-8.900E-02
1773	0.3	4.2	2.6	-1.229E-06	-5.176E-03	-3.405E-02
1774	4.6	13.8	3.25	-1.193E-05	1.236E-03	-2.670E-01
1775	30.1	18.8	4.69	-1.193E-05	1.236E-03	-2.670E-01
1776	65.5	20.4	6.71	-1.193E-05	1.236E-03	-2.670E-01
1777	82.3	18	8.02	-1.193E-05	1.236E-03	-2.670E-01
1778	49	(^e)	8.05	-1.193E-05	1.236E-03	-2.670E-01
1779	42.4	(^e)	7.53	-1.193E-05	1.236E-03	-2.670E-01
1780	34.8	(^e)	6.92	-1.193E-05	1.236E-03	-2.670E-01
1781	29.4	(^e)	6.48	-1.193E-05	1.236E-03	-2.670E-01
1782	25.5	(^e)	6.17	-1.193E-05	1.236E-03	-2.670E-01
1783	22.5	(^e)	5.93	-1.193E-05	1.236E-03	-2.670E-01
1784	18.6	(^e)	5.63	-1.193E-05	1.236E-03	-2.670E-01
1785	13.6	(^e)	5.22	-1.193E-05	1.236E-03	-2.670E-01
1786	12	9.3	4.97	-1.193E-05	1.236E-03	-2.670E-01
1787	41.9	(^e)	5.43	-1.193E-05	1.236E-03	-2.670E-01
1788	35.6	(^e)	5.06	-1.193E-05	1.236E-03	-2.670E-01
1789	37.1	2	5.14	-1.193E-05	1.236E-03	-2.670E-01
1790	39.1	0.7	5.25	-1.193E-05	1.236E-03	-2.670E-01
1791	41.4	2	5.38	-1.193E-05	1.236E-03	-2.670E-01
1792	42.3	(^e)	5.44	-1.193E-05	1.236E-03	-2.670E-01
1793	39	(^e)	5.26	-1.193E-05	1.236E-03	-2.670E-01
1794	36.5	0.4	5.1	-1.193E-05	1.236E-03	-2.670E-01
1795	40.6	4.2	5.33	-1.193E-05	1.236E-03	-2.670E-01
1796	49.4	4.5	5.84	-1.193E-05	1.236E-03	-2.670E-01
1797	55	1	6.17	-1.193E-05	1.236E-03	-2.670E-01
1798	53	(^e)	6.06	-1.193E-05	1.236E-03	-2.670E-01
1799	48.6	(^e)	5.81	-1.193E-05	1.236E-03	-2.670E-01
1800	49.8	3.9	5.86	-1.193E-05	1.236E-03	-2.670E-01
1801	60.1	4.3	6.45	-1.193E-05	1.236E-03	-2.670E-01
1802	59.2	12.8	6.71	-3.978E-06	4.119E-04	-8.900E-02
1803	35.1	(^e)	6.94	3.978E-06	-4.119E-04	8.900E-02
1804	29.4	(^e)	6.49	1.193E-05	-1.236E-03	2.670E-01
1805	23.2	(^e)	5.99	1.193E-05	-1.236E-03	2.670E-01
1806	13.8	(^e)	5.25	1.193E-05	-1.236E-03	2.670E-01
1807	20.3	7.8	3.96	1.193E-05	-1.236E-03	2.670E-01
1808	0	0	3.07	1.193E-05	-1.236E-03	2.670E-01
1809	0	0	2.21	1.193E-05	-1.236E-03	2.670E-01
1810	0	0	0.78	3.978E-06	-4.119E-04	8.900E-02
1811	7.1	19.8	1.71	-3.978E-06	4.119E-04	-8.900E-02
1812	19.5	10.8	2.93	-1.193E-05	1.236E-03	-2.670E-01
1813	43.5	8.5	3.89	-1.193E-05	1.236E-03	-2.670E-01

1814	61.5	5.7	4.64	-1.193E-05	1.236E-03	-2.670E-01
1815	39.7	5.8	4.98	-1.193E-05	1.236E-03	-2.670E-01
1816	33.9	(°)	4.96	-1.193E-05	1.236E-03	-2.670E-01
1817	33	1.1	4.9	-1.193E-05	1.236E-03	-2.670E-01
1818	37.8	3.2	5.17	-1.193E-05	1.236E-03	-2.670E-01
1819	36.2	(°)	5.1	-1.193E-05	1.236E-03	-2.670E-01
1820	36.4	2.4	5.09	-1.193E-05	1.236E-03	-2.670E-01
1821	44	5.4	5.52	-1.193E-05	1.236E-03	-2.670E-01
1822	49	0.9	5.82	-1.193E-05	1.236E-03	-2.670E-01
1823	52.2	2.6	6.01	-1.193E-05	1.236E-03	-2.670E-01
1824	55.4	1.1	6.19	-1.193E-05	1.236E-03	-2.670E-01
1825	58.4	2.2	6.36	-1.193E-05	1.236E-03	-2.670E-01
1826	66.4	9.6	6.81	-1.193E-05	1.236E-03	-2.670E-01
1827	37.6	1.9	7.12	-1.193E-05	1.236E-03	-2.670E-01
1828	37.6	(°)	7.12	-1.193E-05	1.236E-03	-2.670E-01
1829	39.3	1.9	7.26	-1.193E-05	1.236E-03	-2.670E-01
1830	42.6	2.4	7.52	-1.193E-05	1.236E-03	-2.670E-01
1831	44.4	0.2	7.66	-1.193E-05	1.236E-03	-2.670E-01
1832	45.7	0.9	7.77	-1.193E-05	1.236E-03	-2.670E-01
1833	48	1	7.95	-3.978E-06	4.119E-04	-8.900E-02
1834	45	(°)	7.73	3.978E-06	-4.119E-04	8.900E-02
1835	38.7	(°)	7.23	1.193E-05	-1.236E-03	2.670E-01
1836	32.8	(°)	6.76	1.193E-05	-1.236E-03	2.670E-01
1837	25.6	(°)	6.2	1.193E-05	-1.236E-03	2.670E-01
1838	4.9	0.8	4.18	3.978E-06	-4.119E-04	8.900E-02
1839	0.1	3.9	0	-3.978E-06	4.119E-04	-8.900E-02
1840	0	0	0	-1.193E-05	1.236E-03	-2.670E-01
1852	0	0	0	-1.193E-05	1.236E-03	-2.670E-01
1853	1	6.7	0.15	-1.193E-05	1.236E-03	-2.670E-01
1854	6.8	21.9	1.3	-1.193E-05	1.236E-03	-2.670E-01
1855	17.1	11.1	2.83	-1.193E-05	1.236E-03	-2.670E-01
1856	35	5.6	3.56	-1.193E-05	1.236E-03	-2.670E-01
1857	35.7	(°)	3.61	-1.193E-05	1.236E-03	-2.670E-01
1858	21.8	(°)	3.05	-1.193E-05	1.236E-03	-2.670E-01
1859	0	0	1.16	-1.193E-05	1.236E-03	-2.670E-01
1860	0	0	0	-1.193E-05	1.236E-03	-2.670E-01
1865	0	0	0	-1.193E-05	1.236E-03	-2.670E-01
1866	2.5	6.8	0.17	-1.193E-05	1.236E-03	-2.670E-01
1867	5.6	12.3	1.42	-1.193E-05	1.236E-03	-2.670E-01
1868	4.4	4.8	1.97	-1.193E-05	1.236E-03	-2.670E-01
1869	0	0	1.94	-1.193E-05	1.236E-03	-2.670E-01
1870	0	0	0.16	-1.193E-05	1.236E-03	-2.670E-01
1871	0	0	0	-1.193E-05	1.236E-03	-2.670E-01
1872	1.6	6.5	0.17	-1.193E-05	1.236E-03	-2.670E-01
1873	5.1	9.6	1.08	-1.193E-05	1.236E-03	-2.670E-01
1874	3.4	5.8	1.54	-1.193E-05	1.236E-03	-2.670E-01
1875	0	0	1.56	-1.193E-05	1.236E-03	-2.670E-01
1876	0	0	0	-1.193E-05	1.236E-03	-2.670E-01
1878	0	0	0	-1.193E-05	1.236E-03	-2.670E-01
1879	1.3	6.6	0.18	-1.193E-05	1.236E-03	-2.670E-01
1880	4.8	7.7	0.88	-1.193E-05	1.236E-03	-2.670E-01
1881	0.8	5.4	1.29	-1.193E-05	1.236E-03	-2.670E-01
1882	0	0	1.67	-1.193E-05	1.236E-03	-2.670E-01
1883	0.3	4.4	2.01	-1.193E-05	1.236E-03	-2.670E-01
1884	0	0	2.09	-1.193E-05	1.236E-03	-2.670E-01
1885	0	0	2.14	-1.193E-05	1.236E-03	-2.670E-01
1886	0	0	2.12	-1.193E-05	1.236E-03	-2.670E-01
1887	0	0	1.9	-1.193E-05	1.236E-03	-2.670E-01
1888	0	0	0.4	-1.193E-05	1.236E-03	-2.670E-01
1889	0	0	0	-1.193E-05	1.236E-03	-2.670E-01
1899	0	0	0	-1.193E-05	1.236E-03	-2.670E-01
1900	0	0	0	-7.980E-06	-5.261E-04	6.348E-01
1901	0	0	0	-4.026E-06	-2.288E-03	1.537E+00
1902	0	0	0	-7.340E-08	-4.050E-03	2.438E+00
2135	0	0	0	-7.340E-08	-4.050E-03	2.438E+00
2136	51.7	18.5	4.1	-7.340E-08	-4.050E-03	2.438E+00

2137	10.6	6.5	3.04	-7.340E-08	-4.050E-03	2.438E+00
2138	0	0	2.62	-7.340E-08	-4.050E-03	2.438E+00
2139	18.6	7.7	3.59	-7.340E-08	-4.050E-03	2.438E+00
2140	6.2	0.7	2.95	-7.340E-08	-4.050E-03	2.438E+00
2141	0	0	0	-7.340E-08	-4.050E-03	2.438E+00
2167	0	0	0	-7.340E-08	-4.050E-03	2.438E+00
2168	7.1	34.5	0.61	-7.340E-08	-4.050E-03	2.438E+00
2169	10.6	19.6	2.34	-7.340E-08	-4.050E-03	2.438E+00
2170	29.3	11.2	3.07	-7.340E-08	-4.050E-03	2.438E+00
2171	41.5	3.5	3.52	-7.340E-08	-4.050E-03	2.438E+00
2172	37	(°)	3.36	-7.340E-08	-4.050E-03	2.438E+00
2173	22.1	(°)	2.8	-7.340E-08	-4.050E-03	2.438E+00
2174	2.6	0.5	1.82	-7.340E-08	-4.050E-03	2.438E+00
2175	0.1	2.5	0	-7.340E-08	-4.050E-03	2.438E+00
2176	8.3	41.2	1.26	-7.340E-08	-4.050E-03	2.438E+00
2177	27	19.8	2.97	-7.340E-08	-4.050E-03	2.438E+00
2178	48.7	11.1	3.78	-7.340E-08	-4.050E-03	2.438E+00
2179	61.9	9.8	4.28	-7.340E-08	-4.050E-03	2.438E+00
2180	30.5	2.3	4.11	-7.340E-08	-4.050E-03	2.438E+00
2181	25.4	(°)	3.95	-7.340E-08	-4.050E-03	2.438E+00
2182	5.8	0.5	2.82	-7.340E-08	-4.050E-03	2.438E+00
2183	0	0	0	-7.340E-08	-4.050E-03	2.438E+00
2192	0	0	0	-7.340E-08	-4.050E-03	2.438E+00
2193	0.9	7.1	0.05	-7.340E-08	-4.050E-03	2.438E+00
2194	8.1	40.6	1.58	-7.340E-08	-4.050E-03	2.438E+00
2195	27.4	18.8	2.99	-7.340E-08	-4.050E-03	2.438E+00
2196	46.8	10	3.71	-7.340E-08	-4.050E-03	2.438E+00
2197	54.8	2	4.02	-7.340E-08	-4.050E-03	2.438E+00
2198	54.2	1.2	4	-7.340E-08	-4.050E-03	2.438E+00
2199	50.7	2.7	3.87	-7.340E-08	-4.050E-03	2.438E+00
2200	50.4	4.4	3.85	-7.340E-08	-4.050E-03	2.438E+00
2201	53.4	4	3.97	-7.340E-08	-4.050E-03	2.438E+00
2202	56.1	3.1	4.07	-7.340E-08	-4.050E-03	2.438E+00
2203	34.8	6.4	4.13	-7.340E-08	-4.050E-03	2.438E+00
2204	31.5	2.3	4.25	-7.340E-08	-4.050E-03	2.438E+00
2205	32.1	2.4	4.28	-7.340E-08	-4.050E-03	2.438E+00
2206	31.4	2.7	4.24	-7.340E-08	-4.050E-03	2.438E+00
2207	31.4	2.4	4.24	-7.340E-08	-4.050E-03	2.438E+00
2208	32.5	2.3	4.3	-7.340E-08	-4.050E-03	2.438E+00
2209	31.8	1.5	4.27	-7.340E-08	-4.050E-03	2.438E+00
2210	29.8	(°)	4.17	-7.340E-08	-4.050E-03	2.438E+00
2211	21.4	(°)	3.74	-7.340E-08	-4.050E-03	2.438E+00
2212	8.8	0.5	3.11	-7.340E-08	-4.050E-03	2.438E+00
2213	0	0	0	-7.340E-08	-4.050E-03	2.438E+00
2222	0	0	0	-7.340E-08	-4.050E-03	2.438E+00
2223	3.6	10.8	0.05	-7.340E-08	-4.050E-03	2.438E+00
2224	6.7	25.7	1.52	-7.340E-08	-4.050E-03	2.438E+00
2225	14.1	13.6	2.48	-7.340E-08	-4.050E-03	2.438E+00
2226	27.4	8	3	-7.340E-08	-4.050E-03	2.438E+00
2227	44	10.3	3.6	-7.340E-08	-4.050E-03	2.438E+00
2228	59	7.6	4.17	-7.340E-08	-4.050E-03	2.438E+00
2229	33.4	1.8	4.21	-7.340E-08	-4.050E-03	2.438E+00
2230	39.5	11.1	4.64	-7.340E-08	-4.050E-03	2.438E+00
2231	47.5	4.3	5.06	-7.340E-08	-4.050E-03	2.438E+00
2232	43.9	(°)	4.89	-7.340E-08	-4.050E-03	2.438E+00
2233	33.7	(°)	4.37	-7.340E-08	-4.050E-03	2.438E+00
2234	21.6	(°)	3.76	-7.340E-08	-4.050E-03	2.438E+00
2235	10.3	(°)	3.18	-7.340E-08	-4.050E-03	2.438E+00
2236	0	0	2.52	-7.340E-08	-4.050E-03	2.438E+00
2237	0	0	0.23	-7.340E-08	-4.050E-03	2.438E+00
2238	0	0	0	-7.340E-08	-4.050E-03	2.438E+00
2239	0	0	0	-7.340E-08	-4.050E-03	2.438E+00
2240	0	0	0	2.707E-06	-6.116E-03	2.089E+00
2241	0	0	0	5.488E-06	-8.182E-03	1.740E+00
2242	0	0	0	8.269E-06	-1.025E-02	1.390E+00
2298	0	0	0	8.269E-06	-1.025E-02	1.390E+00

2299	2.1	7.2	0	8.269E-06	-1.025E-02	1.390E+00
2300	8.7	49.6	1.87	8.269E-06	-1.025E-02	1.390E+00
2301	51.5	35.1	3.84	8.269E-06	-1.025E-02	1.390E+00
2302	68.4	21.2	5.23	8.269E-06	-1.025E-02	1.390E+00
2303	72.7	25.8	6.26	8.269E-06	-1.025E-02	1.390E+00
2304	57.9	7.7	7.16	8.269E-06	-1.025E-02	1.390E+00
2305	58.4	36.2	7.53	8.269E-06	-1.025E-02	1.390E+00
2306	106.4	37.8	10.52	8.269E-06	-1.025E-02	1.390E+00
2307	32.6	2.2	10.28	8.269E-06	-1.025E-02	1.390E+00
2308	42.1	98.8	11.65	8.269E-06	-1.025E-02	1.390E+00
2309	64.9	21	14.54	2.756E-06	-3.416E-03	4.635E-01
2310	65	0.2	14.6	-2.756E-06	3.416E-03	-4.635E-01
2311	36.2	(°)	14.29	-8.269E-06	1.025E-02	-1.390E+00
2312	29.8	(°)	13.76	-8.269E-06	1.025E-02	-1.390E+00
2313	25.8	(°)	13.08	-8.269E-06	1.025E-02	-1.390E+00
2314	22.5	(°)	12.52	-8.269E-06	1.025E-02	-1.390E+00
2315	19.3	(°)	11.99	-8.269E-06	1.025E-02	-1.390E+00
2316	17	(°)	11.6	-8.269E-06	1.025E-02	-1.390E+00
2317	15.4	4.1	11.32	-8.269E-06	1.025E-02	-1.390E+00
2318	14.4	1.5	11.15	-8.269E-06	1.025E-02	-1.390E+00
2319	12.9	(°)	10.91	-8.269E-06	1.025E-02	-1.390E+00
2320	11.6	8.8	10.11	-8.269E-06	1.025E-02	-1.390E+00
2321	24.3	1.8	9.3	-8.269E-06	1.025E-02	-1.390E+00
2322	18.2	(°)	8.77	-8.269E-06	1.025E-02	-1.390E+00
2323	14.3	(°)	8.28	-8.269E-06	1.025E-02	-1.390E+00
2324	9.9	(°)	7.75	-8.269E-06	1.025E-02	-1.390E+00
2325	10.9	3	5.41	-8.269E-06	1.025E-02	-1.390E+00
2326	5.6	0.7	2.62	-8.269E-06	1.025E-02	-1.390E+00
2327	0	0	1.42	-8.269E-06	1.025E-02	-1.390E+00
2328	3.4	7	1.3	-2.756E-06	3.416E-03	-4.635E-01
2329	6.3	10.9	2.04	2.756E-06	-3.416E-03	4.635E-01
2330	6.2	3.5	2.17	8.269E-06	-1.025E-02	1.390E+00
2331	0	0	1.97	8.269E-06	-1.025E-02	1.390E+00
2332	0	0	1.16	8.269E-06	-1.025E-02	1.390E+00
2333	8.7	36.1	1.99	8.269E-06	-1.025E-02	1.390E+00
2334	47.4	34.5	3.7	8.269E-06	-1.025E-02	1.390E+00
2335	74.6	30.1	4.78	8.269E-06	-1.025E-02	1.390E+00
2336	38.3	1.3	4.59	8.269E-06	-1.025E-02	1.390E+00
2337	88.1	38	7.02	8.269E-06	-1.025E-02	1.390E+00
2338	50.5	0.8	6.88	8.269E-06	-1.025E-02	1.390E+00
2339	68.9	46.4	8.24	8.269E-06	-1.025E-02	1.390E+00
2340	69.6	16.4	9.79	8.269E-06	-1.025E-02	1.390E+00
2341	55.1	35.9	9.94	8.269E-06	-1.025E-02	1.390E+00
2342	83.9	29.4	12.63	8.269E-06	-1.025E-02	1.390E+00
2343	87.2	12.3	12.98	8.269E-06	-1.025E-02	1.390E+00
2344	58.8	6.3	13.3	8.269E-06	-1.025E-02	1.390E+00
2345	59.1	52.5	13.78	8.269E-06	-1.025E-02	1.390E+00
2346	85.8	67.1	17.03	8.269E-06	-1.025E-02	1.390E+00
2347	67.4	11.5	18.36	8.269E-06	-1.025E-02	1.390E+00
2348	56.8	47.6	18.22	8.269E-06	-1.025E-02	1.390E+00
2349	69.9	76.1	20.33	8.269E-06	-1.025E-02	1.390E+00
2350	86.8	76.3	23.13	8.269E-06	-1.025E-02	1.390E+00
2351	49.1	0.6	22.57	8.269E-06	-1.025E-02	1.390E+00
2352	45.4	64.4	22.1	8.269E-06	-1.025E-02	1.390E+00
2353	51.4	80.2	23.4	8.269E-06	-1.025E-02	1.390E+00
2354	60.2	89.5	25.38	8.269E-06	-1.025E-02	1.390E+00
2355	69.5	87.4	27.47	8.269E-06	-1.025E-02	1.390E+00
2356	77.8	85.8	29.37	8.269E-06	-1.025E-02	1.390E+00
2357	48.5	7.2	29.12	8.269E-06	-1.025E-02	1.390E+00
2358	40.2	50.8	28.2	8.269E-06	-1.025E-02	1.390E+00
2359	42	78.2	28.69	8.269E-06	-1.025E-02	1.390E+00
2360	45.9	91.3	29.83	8.269E-06	-1.025E-02	1.390E+00
2361	50.4	95.9	31.2	8.269E-06	-1.025E-02	1.390E+00
2362	50.7	6.9	31.45	8.269E-06	-1.025E-02	1.390E+00
2363	48.4	11.9	30.75	2.756E-06	-3.416E-03	4.635E-01
2364	49.2	(°)	31.06	-2.756E-06	3.416E-03	-4.635E-01

2365	45.8	(^e)	30.05	-8.269E-06	1.025E-02	-1.390E+00
2366	44.2	(^e)	29.49	-8.269E-06	1.025E-02	-1.390E+00
2367	41.5	(^e)	28.7	-8.269E-06	1.025E-02	-1.390E+00
2368	38.7	(^e)	27.84	-8.269E-06	1.025E-02	-1.390E+00
2369	36.4	(^e)	27.12	-8.269E-06	1.025E-02	-1.390E+00
2370	34.2	(^e)	26.47	-8.269E-06	1.025E-02	-1.390E+00
2371	33.2	(^e)	26.14	-8.269E-06	1.025E-02	-1.390E+00
2372	31.5	(^e)	25.6	-8.269E-06	1.025E-02	-1.390E+00
2373	30.4	(^e)	25.27	-8.269E-06	1.025E-02	-1.390E+00
2374	29.3	13.2	24.91	-8.269E-06	1.025E-02	-1.390E+00
2375	28.7	(^e)	24.76	-8.269E-06	1.025E-02	-1.390E+00
2376	23.6	(^e)	23.24	-8.269E-06	1.025E-02	-1.390E+00
2377	16.8	3.9	20.72	-8.269E-06	1.025E-02	-1.390E+00
2378	36	(^e)	20.05	-8.269E-06	1.025E-02	-1.390E+00
2379	36.6	(^e)	20.21	-8.269E-06	1.025E-02	-1.390E+00
2380	32.9	(^e)	19.43	-8.269E-06	1.025E-02	-1.390E+00
2381	26.9	(^e)	18.01	-8.269E-06	1.025E-02	-1.390E+00
2382	26.4	(^e)	17.88	-8.269E-06	1.025E-02	-1.390E+00
2383	25.6	(^e)	17.73	-8.269E-06	1.025E-02	-1.390E+00
2384	18.1	(^e)	16.06	-8.269E-06	1.025E-02	-1.390E+00
2385	33	5.8	13.87	-8.269E-06	1.025E-02	-1.390E+00
2386	19.4	(^e)	12.07	-8.269E-06	1.025E-02	-1.390E+00
2387	9.8	4.3	10.05	-8.269E-06	1.025E-02	-1.390E+00
2388	20.7	1.1	8.91	-8.269E-06	1.025E-02	-1.390E+00
2389	18.7	(^e)	8.83	-8.269E-06	1.025E-02	-1.390E+00
2390	13.9	(^e)	8.25	-8.269E-06	1.025E-02	-1.390E+00
2391	12.8	(^e)	8.1	-2.756E-06	3.416E-03	-4.635E-01
2392	14.2	(^e)	8.27	2.756E-06	-3.416E-03	4.635E-01
2393	16.4	4.2	8.54	8.269E-06	-1.025E-02	1.390E+00
2394	21.4	9.2	9.15	8.269E-06	-1.025E-02	1.390E+00
2395	23.7	4.3	9.45	8.269E-06	-1.025E-02	1.390E+00
2396	24.9	5.7	9.59	8.269E-06	-1.025E-02	1.390E+00
2397	27.2	6.4	9.87	8.269E-06	-1.025E-02	1.390E+00
2398	29.1	10.6	10.11	8.269E-06	-1.025E-02	1.390E+00
2399	34.4	19.3	10.75	8.269E-06	-1.025E-02	1.390E+00
2400	44.5	25.5	12	8.269E-06	-1.025E-02	1.390E+00
2401	55.9	22	13.43	8.269E-06	-1.025E-02	1.390E+00
2402	58	4.2	13.72	8.269E-06	-1.025E-02	1.390E+00
2403	50.3	14.9	13.98	8.269E-06	-1.025E-02	1.390E+00
2404	31.4	31.9	13.97	8.269E-06	-1.025E-02	1.390E+00
2405	38.9	18.9	15.25	8.269E-06	-1.025E-02	1.390E+00
2406	39.4	(^e)	15.36	8.269E-06	-1.025E-02	1.390E+00
2407	36.4	(^e)	14.87	8.269E-06	-1.025E-02	1.390E+00
2408	31.3	(^e)	14.03	8.269E-06	-1.025E-02	1.390E+00
2409	24.5	(^e)	12.87	8.269E-06	-1.025E-02	1.390E+00
2410	18.6	(^e)	11.89	8.269E-06	-1.025E-02	1.390E+00
2411	14.9	(^e)	11.27	8.269E-06	-1.025E-02	1.390E+00
2412	8.9	(^e)	10.3	8.269E-06	-1.025E-02	1.390E+00
2413	33	6	10.6	8.269E-06	-1.025E-02	1.390E+00
2414	36.4	28.9	11.01	8.269E-06	-1.025E-02	1.390E+00
2415	45.1	24.4	12.08	8.269E-06	-1.025E-02	1.390E+00
2416	50.9	12.1	12.82	8.269E-06	-1.025E-02	1.390E+00
2417	54.2	6.3	13.24	8.269E-06	-1.025E-02	1.390E+00
2418	53.3	(^e)	13.14	8.269E-06	-1.025E-02	1.390E+00
2419	52.5	3.6	13.04	8.269E-06	-1.025E-02	1.390E+00
2420	53.9	6.8	13.2	8.269E-06	-1.025E-02	1.390E+00
2421	54.2	7.5	13.24	8.269E-06	-1.025E-02	1.390E+00
2422	53	6	13.09	8.269E-06	-1.025E-02	1.390E+00
2423	54.2	7.9	13.24	8.269E-06	-1.025E-02	1.390E+00
2424	57.8	8.1	13.69	8.269E-06	-1.025E-02	1.390E+00
2425	61.4	14	14.12	8.269E-06	-1.025E-02	1.390E+00
2426	34.1	1	14.14	8.269E-06	-1.025E-02	1.390E+00
2427	38.7	56.4	15.16	8.269E-06	-1.025E-02	1.390E+00
2428	57.6	68.8	18.28	8.269E-06	-1.025E-02	1.390E+00
2429	68.9	33.9	20.25	4.866E-06	-6.427E-03	5.912E-01
2430	79.9	55.8	22.04	1.464E-06	-2.605E-03	-2.080E-01

2431	72.1	21.5	23.5	-1.939E-06	1.217E-03	-1.007E+00
2432	51.1	43.7	23.42	-1.939E-06	1.217E-03	-1.007E+00
2433	59.3	80.6	25.21	-1.939E-06	1.217E-03	-1.007E+00
2434	71.3	82	27.89	-1.939E-06	1.217E-03	-1.007E+00
2435	78.4	27.2	29.63	-1.939E-06	1.217E-03	-1.007E+00
2436	45.9	2.1	29.47	-1.939E-06	1.217E-03	-1.007E+00
2437	46.3	70.5	30.03	-1.939E-06	1.217E-03	-1.007E+00
2438	52.4	83.4	31.83	-1.939E-06	1.217E-03	-1.007E+00
2439	59.1	50.7	33.93	-1.939E-06	1.217E-03	-1.007E+00
2440	59.6	21.4	34.17	-1.939E-06	1.217E-03	-1.007E+00
2441	61.4	19	34.46	-1.939E-06	1.217E-03	-1.007E+00
2442	30.4	2.9	34.14	-1.939E-06	1.217E-03	-1.007E+00
2443	31	36.2	34.54	-1.939E-06	1.217E-03	-1.007E+00
2444	31.7	30.6	34.83	-1.939E-06	1.217E-03	-1.007E+00
2445	32.1	13	35.01	-1.939E-06	1.217E-03	-1.007E+00
2446	32.1	22	35	-1.939E-06	1.217E-03	-1.007E+00
2447	31.8	(^e)	34.93	-1.939E-06	1.217E-03	-1.007E+00
2448	31.2	17.8	34.64	-1.939E-06	1.217E-03	-1.007E+00
2449	30.8	(^e)	34.51	-1.939E-06	1.217E-03	-1.007E+00
2450	29.5	(^e)	33.99	-1.939E-06	1.217E-03	-1.007E+00
2451	28.4	(^e)	33.51	-1.939E-06	1.217E-03	-1.007E+00
2452	28.4	28.8	33.46	-1.939E-06	1.217E-03	-1.007E+00
2453	29.1	23.2	33.77	-1.939E-06	1.217E-03	-1.007E+00
2454	29.8	21.1	34.07	-1.939E-06	1.217E-03	-1.007E+00
2455	30.6	19.6	34.4	-1.939E-06	1.217E-03	-1.007E+00
2456	31.6	15	34.8	-1.939E-06	1.217E-03	-1.007E+00
2457	32.4	7.4	35.18	-1.939E-06	1.217E-03	-1.007E+00
2458	33.4	7.3	35.58	-1.939E-06	1.217E-03	-1.007E+00
2459	34.2	(^e)	35.94	-1.939E-06	1.217E-03	-1.007E+00
2460	35	(^e)	36.27	-1.939E-06	1.217E-03	-1.007E+00
2461	35.8	(^e)	36.6	-1.939E-06	1.217E-03	-1.007E+00
2462	36	(^e)	36.71	-1.939E-06	1.217E-03	-1.007E+00
2463	35.9	(^e)	36.64	-1.939E-06	1.217E-03	-1.007E+00
2464	35.6	(^e)	36.51	-1.939E-06	1.217E-03	-1.007E+00
2465	34.9	(^e)	36.22	-1.939E-06	1.217E-03	-1.007E+00
2466	34	(^e)	35.86	-1.939E-06	1.217E-03	-1.007E+00
2467	33.3	16.5	35.53	-1.939E-06	1.217E-03	-1.007E+00
2468	33.2	14.2	35.51	-1.939E-06	1.217E-03	-1.007E+00
2469	33.6	38.9	35.61	-1.939E-06	1.217E-03	-1.007E+00
2470	34.4	47.8	35.93	-1.939E-06	1.217E-03	-1.007E+00
2471	34.9	38.6	36.15	-1.939E-06	1.217E-03	-1.007E+00
2472	34.8	40.6	36.09	-1.939E-06	1.217E-03	-1.007E+00
2473	34.7	45.1	36.05	-1.939E-06	1.217E-03	-1.007E+00
2474	34.3	38.1	35.92	-1.939E-06	1.217E-03	-1.007E+00
2475	34.4	60.8	35.91	-1.939E-06	1.217E-03	-1.007E+00
2476	33.6	(^e)	35.69	-1.939E-06	1.217E-03	-1.007E+00
2477	30.3	1	34.29	-1.939E-06	1.217E-03	-1.007E+00
2478	28.4	(^e)	33.5	-1.939E-06	1.217E-03	-1.007E+00
2479	26.7	11.3	32.79	-1.939E-06	1.217E-03	-1.007E+00
2480	26.4	37.8	32.61	-1.939E-06	1.217E-03	-1.007E+00
2481	27.2	60.2	32.93	-1.939E-06	1.217E-03	-1.007E+00
2482	30	78.9	34.07	-1.939E-06	1.217E-03	-1.007E+00
2483	32	65.3	34.93	-1.939E-06	1.217E-03	-1.007E+00
2484	33.1	11.8	35.46	-1.939E-06	1.217E-03	-1.007E+00
2485	33.4	25.9	35.55	-1.939E-06	1.217E-03	-1.007E+00
2486	34.1	31	35.85	-1.939E-06	1.217E-03	-1.007E+00
2487	34.2	0.5	35.92	-1.939E-06	1.217E-03	-1.007E+00
2488	34.9	47.5	36.12	-1.939E-06	1.217E-03	-1.007E+00
2489	36.9	39.9	37	-1.939E-06	1.217E-03	-1.007E+00
2490	38.1	44.3	37.5	-1.939E-06	1.217E-03	-1.007E+00
2491	40.2	62.9	38.31	-1.939E-06	1.217E-03	-1.007E+00
2492	42.4	52.1	39.27	-1.939E-06	1.217E-03	-1.007E+00
2493	42.9	4.8	39.53	-1.939E-06	1.217E-03	-1.007E+00
2494	42.5	12.5	39.36	-1.939E-06	1.217E-03	-1.007E+00
2495	42.5	17	39.34	-1.939E-06	1.217E-03	-1.007E+00
2496	42.7	28	39.43	-1.939E-06	1.217E-03	-1.007E+00

2497	42.8	15	39.5	-1.939E-06	1.217E-03	-1.007E+00
2498	42.9	17.8	39.51	-1.939E-06	1.217E-03	-1.007E+00
2499	43	21.5	39.57	-1.939E-06	1.217E-03	-1.007E+00
2500	43.2	20	39.64	-1.939E-06	1.217E-03	-1.007E+00
2501	43.5	24.6	39.76	-1.939E-06	1.217E-03	-1.007E+00
2502	44.2	31.9	40.02	-1.939E-06	1.217E-03	-1.007E+00
2503	44.1	4.6	40.03	-1.939E-06	1.217E-03	-1.007E+00
2504	44	24.5	39.98	-1.939E-06	1.217E-03	-1.007E+00
2505	44	8.7	39.99	-1.939E-06	1.217E-03	-1.007E+00
2506	43.4	4.4	39.75	-1.939E-06	1.217E-03	-1.007E+00
2507	43.1	14	39.6	-1.939E-06	1.217E-03	-1.007E+00
2508	42.6	4.2	39.43	-1.939E-06	1.217E-03	-1.007E+00
2509	41.7	(^e)	39.05	-1.939E-06	1.217E-03	-1.007E+00
2510	41.2	13.6	38.82	-1.939E-06	1.217E-03	-1.007E+00
2511	40.8	6.5	38.69	-1.939E-06	1.217E-03	-1.007E+00
2512	40.7	20.3	38.62	-1.939E-06	1.217E-03	-1.007E+00
2513	39.8	(^e)	38.3	-1.939E-06	1.217E-03	-1.007E+00
2514	39	14.7	37.92	-1.939E-06	1.217E-03	-1.007E+00
2515	39.3	24.9	37.99	-1.939E-06	1.217E-03	-1.007E+00
2516	38.9	(^e)	37.87	-1.939E-06	1.217E-03	-1.007E+00
2517	38.5	15.5	37.69	-1.939E-06	1.217E-03	-1.007E+00
2518	38	(^e)	37.49	-1.939E-06	1.217E-03	-1.007E+00
2519	37.3	7	37.22	-1.939E-06	1.217E-03	-1.007E+00
2520	36.4	(^e)	36.84	-1.939E-06	1.217E-03	-1.007E+00
2521	35.3	(^e)	36.4	-1.939E-06	1.217E-03	-1.007E+00
2522	34.1	(^e)	35.89	-1.939E-06	1.217E-03	-1.007E+00
2523	32.8	(^e)	35.34	-1.939E-06	1.217E-03	-1.007E+00
2524	30.7	(^e)	34.5	-1.939E-06	1.217E-03	-1.007E+00
2525	28.9	(^e)	33.74	-1.939E-06	1.217E-03	-1.007E+00
2526	27.8	(^e)	33.25	-1.939E-06	1.217E-03	-1.007E+00
2527	26.7	(^e)	32.79	-1.939E-06	1.217E-03	-1.007E+00
2528	26.4	20	32.65	-1.939E-06	1.217E-03	-1.007E+00
2529	26.8	24.1	32.81	-1.939E-06	1.217E-03	-1.007E+00
2530	27.1	15.6	32.94	-1.939E-06	1.217E-03	-1.007E+00
2531	27.6	29.9	33.13	-1.939E-06	1.217E-03	-1.007E+00
2532	28.3	31.9	33.43	-1.939E-06	1.217E-03	-1.007E+00
2533	28.6	14.2	33.58	-1.939E-06	1.217E-03	-1.007E+00
2534	29.3	37.8	33.83	-1.939E-06	1.217E-03	-1.007E+00
2535	30.6	43.6	34.36	-1.939E-06	1.217E-03	-1.007E+00
2536	31.9	34.4	34.91	-1.939E-06	1.217E-03	-1.007E+00
2537	31.6	0.9	34.86	-1.939E-06	1.217E-03	-1.007E+00
2538	32.1	38.6	35	-1.939E-06	1.217E-03	-1.007E+00
2539	32.6	0.8	35.28	-1.939E-06	1.217E-03	-1.007E+00
2540	32	(^e)	35.02	-1.939E-06	1.217E-03	-1.007E+00
2541	32	20	34.99	-1.939E-06	1.217E-03	-1.007E+00
2542	32.1	2.5	35.06	-1.939E-06	1.217E-03	-1.007E+00
2543	31.3	(^e)	34.72	-1.939E-06	1.217E-03	-1.007E+00
2544	30.3	(^e)	34.3	-1.939E-06	1.217E-03	-1.007E+00
2545	29.5	(^e)	34.06	-1.939E-06	1.217E-03	-1.007E+00
2546	27.9	(^e)	33.4	-1.939E-06	1.217E-03	-1.007E+00
2547	26.1	(^e)	32.58	-1.939E-06	1.217E-03	-1.007E+00
2548	24.8	(^e)	32.04	-1.939E-06	1.217E-03	-1.007E+00
2549	23.1	39.1	31.24	-1.939E-06	1.217E-03	-1.007E+00
2550	22.3	56.9	30.88	-1.939E-06	1.217E-03	-1.007E+00
2551	24.3	68.3	31.7	-1.939E-06	1.217E-03	-1.007E+00
2552	25.9	40.5	32.4	-1.939E-06	1.217E-03	-1.007E+00
2553	26.8	24.7	32.8	-1.939E-06	1.217E-03	-1.007E+00
2554	27.5	38.9	33.07	-1.939E-06	1.217E-03	-1.007E+00
2555	28.3	44.5	33.4	-1.939E-06	1.217E-03	-1.007E+00
2556	29	26	33.71	-1.939E-06	1.217E-03	-1.007E+00
2557	29.3	28.1	33.82	-1.939E-06	1.217E-03	-1.007E+00
2558	29.8	33.5	34.06	-1.939E-06	1.217E-03	-1.007E+00
2559	30.4	16.3	34.31	-1.939E-06	1.217E-03	-1.007E+00
2560	30.5	17.6	34.34	-1.939E-06	1.217E-03	-1.007E+00
2561	30.4	9.3	34.34	-1.939E-06	1.217E-03	-1.007E+00
2562	30	1	34.16	-1.939E-06	1.217E-03	-1.007E+00

2563	29.1	(^e)	33.82	-1.939E-06	1.217E-03	-1.007E+00
2564	28.4	11.9	33.48	-1.939E-06	1.217E-03	-1.007E+00
2565	28.1	(^e)	33.38	-1.939E-06	1.217E-03	-1.007E+00
2566	28.1	30.8	33.33	-1.939E-06	1.217E-03	-1.007E+00
2567	29.1	37.6	33.75	-1.939E-06	1.217E-03	-1.007E+00
2568	30.3	40.6	34.26	-1.939E-06	1.217E-03	-1.007E+00
2569	31.5	24.7	34.77	-1.939E-06	1.217E-03	-1.007E+00
2570	32.4	37.8	35.1	-1.939E-06	1.217E-03	-1.007E+00
2571	33.7	44.2	35.63	-1.939E-06	1.217E-03	-1.007E+00
2572	35.1	37.5	36.22	-1.939E-06	1.217E-03	-1.007E+00
2573	36.2	38.5	36.7	-1.939E-06	1.217E-03	-1.007E+00
2574	36.2	(^e)	36.77	-1.939E-06	1.217E-03	-1.007E+00
2575	36.2	31	36.7	-1.939E-06	1.217E-03	-1.007E+00
2576	36.8	24.9	36.96	-1.939E-06	1.217E-03	-1.007E+00
2577	37.4	26.1	37.21	-1.939E-06	1.217E-03	-1.007E+00
2578	37.8	25.3	37.4	-1.939E-06	1.217E-03	-1.007E+00
2579	38	15.1	37.48	-1.939E-06	1.217E-03	-1.007E+00
2580	38.1	20.9	37.5	-1.939E-06	1.217E-03	-1.007E+00
2581	38.2	18.4	37.56	-1.939E-06	1.217E-03	-1.007E+00
2582	37.7	(^e)	37.37	-1.939E-06	1.217E-03	-1.007E+00
2583	37.7	29.6	37.34	-1.939E-06	1.217E-03	-1.007E+00
2584	38.4	21.6	37.63	-1.939E-06	1.217E-03	-1.007E+00
2585	38.7	19.5	37.75	-1.939E-06	1.217E-03	-1.007E+00
2586	39.2	28.1	37.96	-1.939E-06	1.217E-03	-1.007E+00
2587	39.8	27.4	38.21	-1.939E-06	1.217E-03	-1.007E+00
2588	40.2	21.7	38.41	-1.939E-06	1.217E-03	-1.007E+00
2589	40.4	21.5	38.48	-1.939E-06	1.217E-03	-1.007E+00
2590	40.9	32.8	38.66	-1.939E-06	1.217E-03	-1.007E+00
2591	41.7	44.7	38.99	-1.939E-06	1.217E-03	-1.007E+00
2592	41.5	(^e)	38.97	-1.939E-06	1.217E-03	-1.007E+00
2593	41	29.5	38.69	-1.939E-06	1.217E-03	-1.007E+00
2594	40.4	12.9	38.48	-1.939E-06	1.217E-03	-1.007E+00
2595	39.7	22.7	38.17	-1.939E-06	1.217E-03	-1.007E+00
2596	39.3	22.7	38	-1.939E-06	1.217E-03	-1.007E+00
2597	38.8	21.6	37.81	-1.939E-06	1.217E-03	-1.007E+00
2598	38.5	34.9	37.67	-1.939E-06	1.217E-03	-1.007E+00
2599	38.4	21.9	37.65	-2.270E-06	1.516E-03	-9.082E-01
2600	38.6	31.5	37.73	-2.601E-06	1.815E-03	-8.092E-01
2601	39.1	10.7	37.96	-2.932E-06	2.115E-03	-7.102E-01
2602	39	9.8	37.89	-2.932E-06	2.115E-03	-7.102E-01
2603	38.9	4.6	37.88	-2.932E-06	2.115E-03	-7.102E-01
2604	40	37.2	38.27	-2.932E-06	2.115E-03	-7.102E-01
2605	40.2	(^e)	38.45	-2.932E-06	2.115E-03	-7.102E-01
2606	41	41.4	38.69	-2.932E-06	2.115E-03	-7.102E-01
2607	42.9	36	39.48	-2.932E-06	2.115E-03	-7.102E-01
2608	42.5	(^e)	39.39	-2.932E-06	2.115E-03	-7.102E-01
2609	41.2	(^e)	38.87	-2.932E-06	2.115E-03	-7.102E-01
2610	40.9	23.2	38.69	-2.932E-06	2.115E-03	-7.102E-01
2611	40.9	8.6	38.71	-2.932E-06	2.115E-03	-7.102E-01
2612	40.4	7.5	38.49	-2.932E-06	2.115E-03	-7.102E-01
2613	40.2	13.8	38.42	-2.932E-06	2.115E-03	-7.102E-01
2614	40.4	23.4	38.48	-2.932E-06	2.115E-03	-7.102E-01
2615	40.9	31.8	38.65	-2.932E-06	2.115E-03	-7.102E-01
2616	41.1	21.4	38.77	-2.932E-06	2.115E-03	-7.102E-01
2617	41.8	39	39.02	-2.932E-06	2.115E-03	-7.102E-01
2618	43.1	38.6	39.58	-2.932E-06	2.115E-03	-7.102E-01
2619	43.1	5.1	39.63	-2.932E-06	2.115E-03	-7.102E-01
2620	43.6	42.2	39.79	-2.932E-06	2.115E-03	-7.102E-01
2621	44.9	40.6	40.32	-2.932E-06	2.115E-03	-7.102E-01
2622	44.2	(^e)	40.09	-2.932E-06	2.115E-03	-7.102E-01
2623	42.8	(^e)	39.52	-2.932E-06	2.115E-03	-7.102E-01
2624	42.2	29.3	39.22	-2.932E-06	2.115E-03	-7.102E-01
2625	41.8	13.5	39.06	-2.932E-06	2.115E-03	-7.102E-01
2626	41.4	30.6	38.86	-2.932E-06	2.115E-03	-7.102E-01
2627	41.2	15.3	38.8	-2.932E-06	2.115E-03	-7.102E-01
2628	40.8	26.4	38.62	-2.932E-06	2.115E-03	-7.102E-01

2629	40.3	21.9	38.44	-2.932E-06	2.115E-03	-7.102E-01
2630	40.2	30.7	38.39	-2.932E-06	2.115E-03	-7.102E-01
2631	40.2	28.1	38.4	-2.932E-06	2.115E-03	-7.102E-01
2632	40	26.8	38.31	-2.932E-06	2.115E-03	-7.102E-01
2633	40.2	36	38.38	-2.932E-06	2.115E-03	-7.102E-01
2634	40.4	30.7	38.46	-2.932E-06	2.115E-03	-7.102E-01
2635	40.7	38.9	38.58	-2.932E-06	2.115E-03	-7.102E-01
2636	41.2	36.4	38.79	-2.932E-06	2.115E-03	-7.102E-01
2637	41.5	36.5	38.93	-2.932E-06	2.115E-03	-7.102E-01
2638	41.8	35.6	39.02	-2.932E-06	2.115E-03	-7.102E-01
2639	42	35.8	39.1	-2.932E-06	2.115E-03	-7.102E-01
2640	41.6	13.2	38.99	-2.932E-06	2.115E-03	-7.102E-01
2641	41	22.6	38.73	-2.932E-06	2.115E-03	-7.102E-01
2642	41.2	36.5	38.77	-2.932E-06	2.115E-03	-7.102E-01
2643	41.4	29.7	38.88	-2.932E-06	2.115E-03	-7.102E-01
2644	41.5	21.1	38.92	-2.932E-06	2.115E-03	-7.102E-01
2645	41.4	21.8	38.91	-2.932E-06	2.115E-03	-7.102E-01
2646	41.5	20.2	38.92	-2.932E-06	2.115E-03	-7.102E-01
2647	41.6	24	38.96	-2.932E-06	2.115E-03	-7.102E-01
2648	41.7	21.9	39.03	-2.932E-06	2.115E-03	-7.102E-01
2649	41.9	25.3	39.07	-2.932E-06	2.115E-03	-7.102E-01
2650	41	(^e)	38.79	-2.932E-06	2.115E-03	-7.102E-01
2651	40.9	36.6	38.67	-2.932E-06	2.115E-03	-7.102E-01
2652	41.2	14.7	38.82	-2.932E-06	2.115E-03	-7.102E-01
2653	41.5	32.6	38.9	-2.932E-06	2.115E-03	-7.102E-01
2654	41.8	21.5	39.05	-2.932E-06	2.115E-03	-7.102E-01
2655	41.8	24.1	39.07	-2.932E-06	2.115E-03	-7.102E-01
2656	42	26.5	39.13	-2.932E-06	2.115E-03	-7.102E-01
2657	42	16.9	39.15	-2.932E-06	2.115E-03	-7.102E-01
2658	41.6	18.7	38.98	-2.932E-06	2.115E-03	-7.102E-01
2659	41.6	33.4	38.93	-2.932E-06	2.115E-03	-7.102E-01
2660	42	42.5	39.1	-2.932E-06	2.115E-03	-7.102E-01
2661	43.5	72	39.66	-2.932E-06	2.115E-03	-7.102E-01
2662	45.9	51.3	40.71	-2.932E-06	2.115E-03	-7.102E-01
2663	45.4	(^e)	40.61	-2.932E-06	2.115E-03	-7.102E-01
2664	46.1	46.3	40.8	-2.932E-06	2.115E-03	-7.102E-01
2665	47.1	(^e)	41.32	-2.932E-06	2.115E-03	-7.102E-01
2666	46.7	9.4	41.11	-2.932E-06	2.115E-03	-7.102E-01
2667	45.7	(^e)	40.74	-2.932E-06	2.115E-03	-7.102E-01
2668	44.4	0.1	40.2	-2.932E-06	2.115E-03	-7.102E-01
2669	43.2	(^e)	39.7	-2.932E-06	2.115E-03	-7.102E-01
2670	42.5	5.9	39.38	-2.932E-06	2.115E-03	-7.102E-01
2671	42.6	7	39.41	-2.932E-06	2.115E-03	-7.102E-01
2672	42.8	8.9	39.52	-2.932E-06	2.115E-03	-7.102E-01
2673	43.2	(^e)	39.69	-2.932E-06	2.115E-03	-7.102E-01
2674	43.4	(^e)	39.78	-2.932E-06	2.115E-03	-7.102E-01
2675	43.7	(^e)	39.91	-2.932E-06	2.115E-03	-7.102E-01
2676	44.2	(^e)	40.1	-2.932E-06	2.115E-03	-7.102E-01
2677	43.3	(^e)	39.81	-2.932E-06	2.115E-03	-7.102E-01
2678	42	(^e)	39.24	-2.932E-06	2.115E-03	-7.102E-01
2679	40.9	(^e)	38.77	-2.932E-06	2.115E-03	-7.102E-01
2680	41	(^e)	38.78	-9.772E-07	7.048E-04	-2.367E-01
2681	40.5	(^e)	38.59	9.772E-07	-7.048E-04	2.367E-01
2682	39	(^e)	37.99	2.932E-06	-2.115E-03	7.102E-01
2683	37.6	(^e)	37.38	2.932E-06	-2.115E-03	7.102E-01
2684	36	(^e)	36.67	2.932E-06	-2.115E-03	7.102E-01
2685	33.2	(^e)	35.53	2.932E-06	-2.115E-03	7.102E-01
2686	32.2	(^e)	35.18	2.932E-06	-2.115E-03	7.102E-01
2687	29.5	(^e)	34.02	2.932E-06	-2.115E-03	7.102E-01
2688	27.2	(^e)	33.01	2.932E-06	-2.115E-03	7.102E-01
2689	24.5	(^e)	31.93	2.932E-06	-2.115E-03	7.102E-01
2690	21.5	(^e)	30.64	2.932E-06	-2.115E-03	7.102E-01
2691	17.9	(^e)	29.19	2.932E-06	-2.115E-03	7.102E-01
2692	37.6	9.6	26.34	2.932E-06	-2.115E-03	7.102E-01
2693	24.4	(^e)	23.47	2.932E-06	-2.115E-03	7.102E-01
2694	19.8	(^e)	22.01	2.932E-06	-2.115E-03	7.102E-01

2695	16.8	15.6	21.07	2.932E-06	-2.115E-03	7.102E-01
2696	38.2	4.6	20.04	2.932E-06	-2.115E-03	7.102E-01
2697	35.3	53.2	19.82	2.932E-06	-2.115E-03	7.102E-01
2698	34.8	(^e)	19.79	2.932E-06	-2.115E-03	7.102E-01
2699	28	(^e)	18.28	2.932E-06	-2.115E-03	7.102E-01
2700	18.9	(^e)	16.18	2.932E-06	-2.115E-03	7.102E-01
2701	40.1	12.9	14.95	2.932E-06	-2.115E-03	7.102E-01
2702	28.6	(^e)	13.58	2.932E-06	-2.115E-03	7.102E-01
2703	16.4	(^e)	11.53	2.932E-06	-2.115E-03	7.102E-01
2704	10.4	(^e)	10.49	2.932E-06	-2.115E-03	7.102E-01
2705	33.4	9.5	10.27	2.932E-06	-2.115E-03	7.102E-01
2706	28.5	3.5	10.04	2.932E-06	-2.115E-03	7.102E-01
2707	29.1	14.7	10.11	9.772E-07	-7.048E-04	2.367E-01
2708	36.1	19.7	10.96	-9.772E-07	7.048E-04	-2.367E-01
2709	43.7	21.1	11.91	-2.932E-06	2.115E-03	-7.102E-01
2710	51.1	14.7	12.84	-2.932E-06	2.115E-03	-7.102E-01
2711	55.9	21.4	13.43	-2.932E-06	2.115E-03	-7.102E-01
2712	66.5	34.1	14.71	-2.932E-06	2.115E-03	-7.102E-01
2713	68.3	19.9	15.86	-2.932E-06	2.115E-03	-7.102E-01
2714	40.6	23.4	15.53	-2.932E-06	2.115E-03	-7.102E-01
2715	53.5	75.5	17.59	-2.932E-06	2.115E-03	-7.102E-01
2716	63.9	17.2	19.44	-2.932E-06	2.115E-03	-7.102E-01
2717	64.5	11.6	19.56	-2.932E-06	2.115E-03	-7.102E-01
2718	36.4	2.4	19.47	-2.932E-06	2.115E-03	-7.102E-01
2719	34.5	50	19.63	-2.932E-06	2.115E-03	-7.102E-01
2720	39.1	24	20.72	-2.932E-06	2.115E-03	-7.102E-01
2721	41.7	26.3	21.3	-2.932E-06	2.115E-03	-7.102E-01
2722	43.6	20.8	21.75	-2.932E-06	2.115E-03	-7.102E-01
2723	45.5	28.8	22.16	-2.932E-06	2.115E-03	-7.102E-01
2724	47.5	27.2	22.62	-2.932E-06	2.115E-03	-7.102E-01
2725	47.6	20.8	22.65	-2.932E-06	2.115E-03	-7.102E-01
2726	48.4	30.2	22.8	-2.932E-06	2.115E-03	-7.102E-01
2727	48.3	20.1	22.8	-2.932E-06	2.115E-03	-7.102E-01
2728	50.2	(^e)	23.3	-9.772E-07	7.048E-04	-2.367E-01
2729	49.6	(^e)	23.19	9.772E-07	-7.048E-04	2.367E-01
2730	46.6	(^e)	22.46	2.932E-06	-2.115E-03	7.102E-01
2731	44.7	(^e)	22.03	2.932E-06	-2.115E-03	7.102E-01
2732	43.1	(^e)	21.67	2.932E-06	-2.115E-03	7.102E-01
2733	41.2	(^e)	21.23	2.932E-06	-2.115E-03	7.102E-01
2734	40.1	1.5	20.97	2.932E-06	-2.115E-03	7.102E-01
2735	39.5	(^e)	20.86	2.932E-06	-2.115E-03	7.102E-01
2736	37.2	(^e)	20.33	2.932E-06	-2.115E-03	7.102E-01
2737	34.7	(^e)	19.76	2.932E-06	-2.115E-03	7.102E-01
2738	29.9	(^e)	18.71	2.932E-06	-2.115E-03	7.102E-01
2739	21.9	(^e)	16.9	2.932E-06	-2.115E-03	7.102E-01
2740	27.2	14.2	14.92	2.932E-06	-2.115E-03	7.102E-01
2741	29.7	0.3	13.71	2.932E-06	-2.115E-03	7.102E-01
2742	24.4	(^e)	12.88	2.932E-06	-2.115E-03	7.102E-01
2743	10.1	(^e)	10.5	2.932E-06	-2.115E-03	7.102E-01
2744	10.4	(^e)	7.5	2.932E-06	-2.115E-03	7.102E-01
2745	16.1	11.8	5.02	2.932E-06	-2.115E-03	7.102E-01
2746	16.5	9.6	3.25	2.932E-06	-2.115E-03	7.102E-01
2747	0	0	0.16	2.932E-06	-2.115E-03	7.102E-01
2748	0	0	0	2.932E-06	-2.115E-03	7.102E-01
2749	0	0	0	2.932E-06	-2.115E-03	7.102E-01
2750	0	0	0	2.537E-06	-2.528E-03	-2.959E-02
2751	0	0	0	2.143E-06	-2.941E-03	-7.694E-01
2752	0	0	0	1.749E-06	-3.354E-03	-1.509E+00
2754	0	0	0	1.749E-06	-3.354E-03	-1.509E+00
2755	5.6	23	0.1	1.749E-06	-3.354E-03	-1.509E+00
2756	19.9	33.9	2.7	1.749E-06	-3.354E-03	-1.509E+00
2757	74.4	32.9	4.69	1.749E-06	-3.354E-03	-1.509E+00
2758	60.9	1	5.72	1.749E-06	-3.354E-03	-1.509E+00
2759	97.8	33.1	7.34	1.749E-06	-3.354E-03	-1.509E+00
2760	55.9	2.2	7.4	1.749E-06	-3.354E-03	-1.509E+00
2761	89.4	50.7	9.63	1.749E-06	-3.354E-03	-1.509E+00

2762	54.9	1.2	9.81	1.749E-06	-3.354E-03	-1.509E+00
2763	71.2	57.1	11.41	1.749E-06	-3.354E-03	-1.509E+00
2764	90.9	17.2	13.4	1.749E-06	-3.354E-03	-1.509E+00
2765	55.2	0.8	13.37	1.749E-06	-3.354E-03	-1.509E+00
2766	75	77.5	15.71	1.749E-06	-3.354E-03	-1.509E+00
2767	85.3	20.8	17.87	1.749E-06	-3.354E-03	-1.509E+00
2768	52.8	13.4	17.59	1.749E-06	-3.354E-03	-1.509E+00
2769	65.9	80.7	19.67	1.749E-06	-3.354E-03	-1.509E+00
2770	85.7	74.1	22.96	1.749E-06	-3.354E-03	-1.509E+00
2771	53.9	0.2	23.66	1.749E-06	-3.354E-03	-1.509E+00
2772	55.1	62.4	24.3	1.749E-06	-3.354E-03	-1.509E+00
2773	65.1	77	26.51	1.749E-06	-3.354E-03	-1.509E+00
2774	77.2	83	29.24	1.749E-06	-3.354E-03	-1.509E+00
2775	51.1	6.5	29.99	1.749E-06	-3.354E-03	-1.509E+00
2776	46.7	52.1	30.18	1.749E-06	-3.354E-03	-1.509E+00
2777	51.7	78.3	31.64	1.749E-06	-3.354E-03	-1.509E+00
2778	58.5	62.4	33.74	1.749E-06	-3.354E-03	-1.509E+00
2779	60.8	33.9	34.5	1.749E-06	-3.354E-03	-1.509E+00
2780	62	48.1	34.83	1.749E-06	-3.354E-03	-1.509E+00
2781	65.4	41.7	35.89	1.749E-06	-3.354E-03	-1.509E+00
2782	67.2	23.3	36.47	1.749E-06	-3.354E-03	-1.509E+00
2783	68.2	10.3	37	1.749E-06	-3.354E-03	-1.509E+00
2784	36.5	3.2	36.85	1.749E-06	-3.354E-03	-1.509E+00
2785	36	7.7	36.65	1.749E-06	-3.354E-03	-1.509E+00
2786	36	27.9	36.64	1.749E-06	-3.354E-03	-1.509E+00
2787	36.5	14.5	36.86	1.749E-06	-3.354E-03	-1.509E+00
2788	35.9	(^e)	36.64	1.749E-06	-3.354E-03	-1.509E+00
2789	34.7	(^e)	36.15	1.749E-06	-3.354E-03	-1.509E+00
2790	33.3	(^e)	35.59	1.749E-06	-3.354E-03	-1.509E+00
2791	32	(^e)	35.04	1.749E-06	-3.354E-03	-1.509E+00
2792	30.6	(^e)	34.44	1.749E-06	-3.354E-03	-1.509E+00
2793	29.2	(^e)	33.85	1.749E-06	-3.354E-03	-1.509E+00
2794	29.2	39.4	33.79	1.749E-06	-3.354E-03	-1.509E+00
2795	30	(^e)	34.16	1.749E-06	-3.354E-03	-1.509E+00
2796	30	36.7	34.11	1.749E-06	-3.354E-03	-1.509E+00
2797	32.3	24.1	35.11	1.749E-06	-3.354E-03	-1.509E+00
2798	33.2	37.9	35.47	1.749E-06	-3.354E-03	-1.509E+00
2799	33.8	53.5	35.68	1.749E-06	-3.354E-03	-1.509E+00
2800	35.7	53.5	36.45	1.749E-06	-3.354E-03	-1.509E+00
2801	36.9	29	37.02	1.749E-06	-3.354E-03	-1.509E+00
2802	37.2	26.9	37.15	1.749E-06	-3.354E-03	-1.509E+00
2803	37.8	1.8	37.44	1.749E-06	-3.354E-03	-1.509E+00
2804	37.4	17.4	37.25	1.749E-06	-3.354E-03	-1.509E+00
2805	37.4	9.8	37.26	1.749E-06	-3.354E-03	-1.509E+00
2806	37.6	16.8	37.3	1.749E-06	-3.354E-03	-1.509E+00
2807	38.5	36.7	37.66	1.749E-06	-3.354E-03	-1.509E+00
2808	38.8	0.3	37.86	1.749E-06	-3.354E-03	-1.509E+00
2809	39.5	(^e)	38.14	1.749E-06	-3.354E-03	-1.509E+00
2810	40.2	(^e)	38.46	1.749E-06	-3.354E-03	-1.509E+00
2811	41.3	38.9	38.82	1.749E-06	-3.354E-03	-1.509E+00
2812	42	59.2	39.1	1.749E-06	-3.354E-03	-1.509E+00
2813	42.8	83.1	39.37	1.749E-06	-3.354E-03	-1.509E+00
2814	44.5	93.3	40.07	1.749E-06	-3.354E-03	-1.509E+00
2815	45.6	19.9	40.66	1.749E-06	-3.354E-03	-1.509E+00
2816	46.3	40.8	40.89	5.830E-07	-1.118E-03	-5.031E-01
2817	45.6	(^e)	40.72	-5.830E-07	1.118E-03	5.031E-01
2818	43.7	(^e)	39.89	-1.749E-06	3.354E-03	1.509E+00
2819	42.4	10.3	39.33	-1.749E-06	3.354E-03	1.509E+00
2820	41.8	20	39.06	-1.749E-06	3.354E-03	1.509E+00
2821	41.6	36.9	38.94	-1.749E-06	3.354E-03	1.509E+00
2822	41	30.8	38.71	-1.749E-06	3.354E-03	1.509E+00
2823	38.3	(^e)	37.68	-1.749E-06	3.354E-03	1.509E+00
2824	35.1	(^e)	36.3	-1.749E-06	3.354E-03	1.509E+00
2825	32.5	5	35.22	-1.749E-06	3.354E-03	1.509E+00
2826	31.5	(^e)	34.89	-1.749E-06	3.354E-03	1.509E+00
2827	29.4	(^e)	34.01	-1.749E-06	3.354E-03	1.509E+00

2828	27.3	17.8	33.02	-1.749E-06	3.354E-03	1.509E+00
2829	26	(^a)	32.53	-1.749E-06	3.354E-03	1.509E+00
2830	24.1	(^a)	31.76	-1.749E-06	3.354E-03	1.509E+00
2831	21.2	2.8	30.51	-1.749E-06	3.354E-03	1.509E+00
2832	18.8	18.7	29.5	-1.749E-06	3.354E-03	1.509E+00
2833	17.5	(^a)	28.98	-1.749E-06	3.354E-03	1.509E+00
2834	37.4	20.4	28.34	-1.749E-06	3.354E-03	1.509E+00
2835	36.9	(^a)	27.3	-1.749E-06	3.354E-03	1.509E+00
2836	31.3	(^a)	25.61	-1.749E-06	3.354E-03	1.509E+00
2837	25.4	(^a)	23.8	-1.749E-06	3.354E-03	1.509E+00
2838	22.2	(^a)	22.76	-1.749E-06	3.354E-03	1.509E+00
2839	20.2	(^a)	22.13	-1.749E-06	3.354E-03	1.509E+00
2840	17.8	(^a)	21.41	-1.749E-06	3.354E-03	1.509E+00
2841	39.4	19.9	20.54	-1.749E-06	3.354E-03	1.509E+00
2842	30.1	(^a)	18.82	-1.749E-06	3.354E-03	1.509E+00
2843	23.8	(^a)	17.32	-1.749E-06	3.354E-03	1.509E+00
2844	18	0.7	15.96	-1.749E-06	3.354E-03	1.509E+00
2845	40.1	10.2	14.79	-1.749E-06	3.354E-03	1.509E+00
2846	30.6	20.8	13.86	-1.749E-06	3.354E-03	1.509E+00
2847	26.2	(^a)	13.15	-1.749E-06	3.354E-03	1.509E+00
2848	22.5	(^a)	12.52	-1.749E-06	3.354E-03	1.509E+00
2849	20.6	(^a)	12.22	-1.749E-06	3.354E-03	1.509E+00
2850	18.4	(^a)	11.84	-1.749E-06	3.354E-03	1.509E+00
2851	17.5	(^a)	11.7	-5.830E-07	1.118E-03	5.031E-01
2852	19	(^a)	11.94	5.830E-07	-1.118E-03	-5.031E-01
2853	21.8	3.9	12.39	1.749E-06	-3.354E-03	-1.509E+00
2854	28.5	24.2	13.5	1.749E-06	-3.354E-03	-1.509E+00
2855	36.5	10	14.85	1.749E-06	-3.354E-03	-1.509E+00
2856	44.9	26	16.23	1.749E-06	-3.354E-03	-1.509E+00
2857	56.8	27.8	18.22	1.749E-06	-3.354E-03	-1.509E+00
2858	61.9	(^a)	19.16	1.749E-06	-3.354E-03	-1.509E+00
2859	55.5	13.5	19.76	1.749E-06	-3.354E-03	-1.509E+00
2860	38.2	(^a)	20.55	1.749E-06	-3.354E-03	-1.509E+00
2861	40.9	(^a)	21.16	1.749E-06	-3.354E-03	-1.509E+00
2862	43.5	(^a)	21.76	1.749E-06	-3.354E-03	-1.509E+00
2863	44.3	(^a)	21.97	1.749E-06	-3.354E-03	-1.509E+00
2864	41.6	(^a)	21.39	1.749E-06	-3.354E-03	-1.509E+00
2865	39.5	(^a)	20.87	1.749E-06	-3.354E-03	-1.509E+00
2866	37.3	(^a)	20.39	1.749E-06	-3.354E-03	-1.509E+00
2867	37	(^a)	20.28	1.749E-06	-3.354E-03	-1.509E+00
2868	37.4	(^a)	20.38	1.749E-06	-3.354E-03	-1.509E+00
2869	37.7	(^a)	20.44	1.749E-06	-3.354E-03	-1.509E+00
2870	38.8	(^a)	20.69	1.749E-06	-3.354E-03	-1.509E+00
2871	39	(^a)	20.75	1.749E-06	-3.354E-03	-1.509E+00
2872	38.5	(^a)	20.63	1.749E-06	-3.354E-03	-1.509E+00
2873	38.5	(^a)	20.63	1.749E-06	-3.354E-03	-1.509E+00
2874	38.7	(^a)	20.67	1.749E-06	-3.354E-03	-1.509E+00
2875	38.6	(^a)	20.64	1.749E-06	-3.354E-03	-1.509E+00
2876	41	7.9	21.18	1.749E-06	-3.354E-03	-1.509E+00
2877	41.1	(^a)	21.21	1.749E-06	-3.354E-03	-1.509E+00
2878	42.5	18.9	21.5	1.749E-06	-3.354E-03	-1.509E+00
2879	46.9	37.1	22.46	1.749E-06	-3.354E-03	-1.509E+00
2880	54	59.6	24.02	1.749E-06	-3.354E-03	-1.509E+00
2881	59.1	32.2	25.23	1.749E-06	-3.354E-03	-1.509E+00
2882	64.1	48.6	26.33	1.749E-06	-3.354E-03	-1.509E+00
2883	71.8	61.2	28.08	1.749E-06	-3.354E-03	-1.509E+00
2884	88.5	48.4	30.11	1.749E-06	-3.354E-03	-1.509E+00
2885	46.5	2.9	29.79	1.749E-06	-3.354E-03	-1.509E+00
2886	47.6	80.3	30.43	1.749E-06	-3.354E-03	-1.509E+00
2887	53.5	84.4	32.17	1.749E-06	-3.354E-03	-1.509E+00
2888	60.7	91.2	34.34	1.749E-06	-3.354E-03	-1.509E+00
2889	68	89.5	36.57	1.749E-06	-3.354E-03	-1.509E+00
2890	83.8	30	38.16	1.749E-06	-3.354E-03	-1.509E+00
2891	38.8	3.1	37.86	1.749E-06	-3.354E-03	-1.509E+00
2892	40.5	84.5	38.44	1.749E-06	-3.354E-03	-1.509E+00
2893	43.8	87.5	39.75	1.749E-06	-3.354E-03	-1.509E+00

2894	47.6	94.8	41.35	1.749E-06	-3.354E-03	-1.509E+00
2895	51.6	97.2	43.01	1.749E-06	-3.354E-03	-1.509E+00
2896	55.2	89.3	44.52	1.749E-06	-3.354E-03	-1.509E+00
2897	57.4	71.7	45.47	1.749E-06	-3.354E-03	-1.509E+00
2898	59.1	71.9	46.15	1.749E-06	-3.354E-03	-1.509E+00
2899	61	85.6	46.91	8.186E-08	-1.400E-03	-1.640E+00
2900	62.4	77.7	47.54	-1.585E-06	5.535E-04	-1.771E+00
2901	63.3	66.2	47.93	-3.252E-06	2.507E-03	-1.901E+00
2902	63.7	57.5	48.09	-3.252E-06	2.507E-03	-1.901E+00
2903	64.8	12.5	48.73	-3.252E-06	2.507E-03	-1.901E+00
2904	36.2	0.2	48.99	-3.252E-06	2.507E-03	-1.901E+00
2905	36.1	40.1	48.91	-3.252E-06	2.507E-03	-1.901E+00
2906	36.4	53.8	49.02	-3.252E-06	2.507E-03	-1.901E+00
2907	37.2	62.7	49.46	-3.252E-06	2.507E-03	-1.901E+00
2908	38.3	67.1	50.09	-3.252E-06	2.507E-03	-1.901E+00
2909	39.6	51.8	50.81	-3.252E-06	2.507E-03	-1.901E+00
2910	40.1	54.1	51.09	-3.252E-06	2.507E-03	-1.901E+00
2911	40.1	34.6	51.12	-3.252E-06	2.507E-03	-1.901E+00
2912	39.8	40.2	50.96	-3.252E-06	2.507E-03	-1.901E+00
2913	40.8	56.1	51.48	-3.252E-06	2.507E-03	-1.901E+00
2914	40.3	37.3	51.21	-3.252E-06	2.507E-03	-1.901E+00
2915	40.6	45.8	51.36	-3.252E-06	2.507E-03	-1.901E+00
2916	40.6	(°)	51.47	-3.252E-06	2.507E-03	-1.901E+00
2917	40	11.8	51.13	-3.252E-06	2.507E-03	-1.901E+00
2918	40.1	18.5	51.14	-3.252E-06	2.507E-03	-1.901E+00
2919	39.2	25.2	50.64	-3.252E-06	2.507E-03	-1.901E+00
2920	38.8	40.6	50.38	-3.252E-06	2.507E-03	-1.901E+00
2921	39	38.4	50.51	-3.252E-06	2.507E-03	-1.901E+00
2922	39	40	50.51	-3.252E-06	2.507E-03	-1.901E+00
2923	38.6	71.7	50.24	-3.252E-06	2.507E-03	-1.901E+00
2924	38.9	89.2	50.37	-3.252E-06	2.507E-03	-1.901E+00
2925	40.1	18.1	51.15	-3.252E-06	2.507E-03	-1.901E+00
2926	40.5	(°)	51.42	-3.252E-06	2.507E-03	-1.901E+00
2927	40.5	(°)	51.4	-1.084E-06	8.357E-04	-6.338E-01
2928	40.1	(°)	51.2	1.084E-06	-8.357E-04	6.338E-01
2929	38.6	(°)	50.4	3.252E-06	-2.507E-03	1.901E+00
2930	36.9	(°)	49.46	3.252E-06	-2.507E-03	1.901E+00
2931	35.6	(°)	48.7	3.252E-06	-2.507E-03	1.901E+00
2932	34.3	(°)	47.97	3.252E-06	-2.507E-03	1.901E+00
2933	33.2	(°)	47.36	3.252E-06	-2.507E-03	1.901E+00
2934	32.4	7.6	46.87	3.252E-06	-2.507E-03	1.901E+00
2935	32.2	(°)	46.78	3.252E-06	-2.507E-03	1.901E+00
2936	31.3	30.2	46.25	3.252E-06	-2.507E-03	1.901E+00
2937	31.9	21.1	46.58	3.252E-06	-2.507E-03	1.901E+00
2938	31.2	8.6	46.21	3.252E-06	-2.507E-03	1.901E+00
2939	31.2	34.6	46.2	3.252E-06	-2.507E-03	1.901E+00
2940	31.4	5.8	46.33	3.252E-06	-2.507E-03	1.901E+00
2941	30.6	(°)	45.9	3.252E-06	-2.507E-03	1.901E+00
2942	29.8	(°)	45.44	3.252E-06	-2.507E-03	1.901E+00
2943	29.4	37.9	45.2	3.252E-06	-2.507E-03	1.901E+00
2944	30.2	66.9	45.55	3.252E-06	-2.507E-03	1.901E+00
2945	30.9	44.1	46.01	3.252E-06	-2.507E-03	1.901E+00
2946	31.1	35.5	46.15	3.252E-06	-2.507E-03	1.901E+00
2947	31.1	9.2	46.18	3.252E-06	-2.507E-03	1.901E+00
2948	30.4	20.2	45.75	3.252E-06	-2.507E-03	1.901E+00
2949	30.5	38.2	45.79	3.252E-06	-2.507E-03	1.901E+00
2950	31	51.1	46.04	3.252E-06	-2.507E-03	1.901E+00
2951	32.1	79.8	46.62	3.252E-06	-2.507E-03	1.901E+00
2952	32.8	30.1	47.1	3.252E-06	-2.507E-03	1.901E+00
2953	32.1	0.1	46.75	3.252E-06	-2.507E-03	1.901E+00
2954	31.2	(°)	46.21	3.252E-06	-2.507E-03	1.901E+00
2955	30.1	(°)	45.66	3.252E-06	-2.507E-03	1.901E+00
2956	29	(°)	45.04	3.252E-06	-2.507E-03	1.901E+00
2957	28.1	0.8	44.54	3.252E-06	-2.507E-03	1.901E+00
2958	28	19.9	44.41	3.252E-06	-2.507E-03	1.901E+00
2959	27.8	22	44.32	3.252E-06	-2.507E-03	1.901E+00

2960	27.4	(^e)	44.13	3.252E-06	-2.507E-03	1.901E+00
2961	26.2	(^e)	43.49	3.252E-06	-2.507E-03	1.901E+00
2962	25.3	(^e)	42.96	3.252E-06	-2.507E-03	1.901E+00
2963	24.7	14.5	42.59	3.252E-06	-2.507E-03	1.901E+00
2964	24.4	34.1	42.43	3.252E-06	-2.507E-03	1.901E+00
2965	24.6	47.9	42.51	3.252E-06	-2.507E-03	1.901E+00
2966	25	59.8	42.68	3.252E-06	-2.507E-03	1.901E+00
2967	25	57.9	42.7	3.252E-06	-2.507E-03	1.901E+00
2968	24.6	66.1	42.5	3.252E-06	-2.507E-03	1.901E+00
2969	24	22.9	42.21	3.252E-06	-2.507E-03	1.901E+00
2970	21.8	40	40.98	3.252E-06	-2.507E-03	1.901E+00
2971	21.7	68.7	40.86	3.252E-06	-2.507E-03	1.901E+00
2972	22.8	(^e)	41.59	3.252E-06	-2.507E-03	1.901E+00
2973	21.1	(^e)	40.72	3.252E-06	-2.507E-03	1.901E+00
2974	18.3	(^e)	39.16	3.252E-06	-2.507E-03	1.901E+00
2975	20.6	10.1	38.09	3.252E-06	-2.507E-03	1.901E+00
2976	40.2	3.7	37.78	1.084E-06	-8.357E-04	6.338E-01
2977	39.6	62.7	38.09	-1.084E-06	8.357E-04	-6.338E-01
2978	41.5	38.1	38.92	-3.252E-06	2.507E-03	-1.901E+00
2979	41.8	11.7	39.06	-3.252E-06	2.507E-03	-1.901E+00
2980	41.6	(^e)	39.04	-3.252E-06	2.507E-03	-1.901E+00
2981	39.9	(^e)	38.34	-3.252E-06	2.507E-03	-1.901E+00
2982	38.9	(^e)	37.87	-3.252E-06	2.507E-03	-1.901E+00
2983	38.2	12.5	37.57	-3.252E-06	2.507E-03	-1.901E+00
2984	37.8	27	37.4	-3.252E-06	2.507E-03	-1.901E+00
2985	38.3	25.4	37.6	-3.252E-06	2.507E-03	-1.901E+00
2986	39	21	37.9	-3.252E-06	2.507E-03	-1.901E+00
2987	39.9	17.6	38.29	-3.252E-06	2.507E-03	-1.901E+00
2988	40.7	36.7	38.56	-3.252E-06	2.507E-03	-1.901E+00
2989	41.1	47.3	38.74	-3.252E-06	2.507E-03	-1.901E+00
2990	40.5	34.5	38.48	-3.252E-06	2.507E-03	-1.901E+00
2991	40.6	3.8	38.57	-3.252E-06	2.507E-03	-1.901E+00
2992	40.2	(^e)	38.45	-3.252E-06	2.507E-03	-1.901E+00
2993	40	(^e)	38.35	-3.252E-06	2.507E-03	-1.901E+00
2994	40.4	18.4	38.47	-3.252E-06	2.507E-03	-1.901E+00
2995	41.7	30.6	39	-3.252E-06	2.507E-03	-1.901E+00
2996	42.6	27.8	39.37	-3.252E-06	2.507E-03	-1.901E+00
2997	43.4	18.8	39.73	-3.252E-06	2.507E-03	-1.901E+00
2998	43.2	15.5	39.66	-3.252E-06	2.507E-03	-1.901E+00
2999	43.5	21.1	39.76	-2.595E-06	1.697E-03	-2.144E+00
3000	43.9	16.5	39.95	-1.937E-06	8.875E-04	-2.387E+00
3001	44.1	11	40.03	-1.279E-06	7.771E-05	-2.629E+00
3002	43.6	0.9	39.83	-1.279E-06	7.771E-05	-2.629E+00
3003	42.8	2.5	39.49	-1.279E-06	7.771E-05	-2.629E+00
3004	42.4	31.4	39.28	-1.279E-06	7.771E-05	-2.629E+00
3005	43.2	48.8	39.59	-1.279E-06	7.771E-05	-2.629E+00
3006	44.3	39.9	40.05	-1.279E-06	7.771E-05	-2.629E+00
3007	44.9	41.2	40.32	-1.279E-06	7.771E-05	-2.629E+00
3008	45.2	46.6	40.41	-1.279E-06	7.771E-05	-2.629E+00
3009	45.7	53.4	40.63	-1.279E-06	7.771E-05	-2.629E+00
3010	46.7	44.3	41.06	-1.279E-06	7.771E-05	-2.629E+00
3011	47.4	40.7	41.35	-1.279E-06	7.771E-05	-2.629E+00
3012	47.7	21.3	41.53	-1.279E-06	7.771E-05	-2.629E+00
3013	46.5	10.7	41.02	-1.279E-06	7.771E-05	-2.629E+00
3014	45.9	14	40.8	-1.279E-06	7.771E-05	-2.629E+00
3015	45.5	12.2	40.6	-1.279E-06	7.771E-05	-2.629E+00
3016	45.4	9.7	40.57	-1.279E-06	7.771E-05	-2.629E+00
3017	45	8.3	40.43	-1.279E-06	7.771E-05	-2.629E+00
3018	44.3	37.6	40.07	-1.279E-06	7.771E-05	-2.629E+00
3019	43.8	63.1	39.82	-1.279E-06	7.771E-05	-2.629E+00
3020	44.9	85.9	40.24	-1.279E-06	7.771E-05	-2.629E+00
3021	48.1	94.1	41.54	-1.279E-06	7.771E-05	-2.629E+00
3022	51	50.2	42.85	-1.279E-06	7.771E-05	-2.629E+00
3023	52.9	22.7	43.67	-1.279E-06	7.771E-05	-2.629E+00
3024	53.3	0.9	43.88	-1.279E-06	7.771E-05	-2.629E+00
3025	52.8	3.9	43.66	-1.279E-06	7.771E-05	-2.629E+00

3026	52.1	(^e)	43.4	-1.279E-06	7.771E-05	-2.629E+00
3027	51.5	(^e)	43.16	-1.279E-06	7.771E-05	-2.629E+00
3028	50.8	(^e)	42.86	-1.279E-06	7.771E-05	-2.629E+00
3029	49.9	(^e)	42.45	-1.279E-06	7.771E-05	-2.629E+00
3030	48.4	20.6	41.79	-1.279E-06	7.771E-05	-2.629E+00
3031	47.7	33.2	41.51	-1.279E-06	7.771E-05	-2.629E+00
3032	48.2	1.7	41.74	-1.279E-06	7.771E-05	-2.629E+00
3033	48.7	(^e)	42.03	-1.279E-06	7.771E-05	-2.629E+00
3034	47.7	(^e)	41.57	-1.279E-06	7.771E-05	-2.629E+00
3035	45.6	38.3	40.62	-1.279E-06	7.771E-05	-2.629E+00
3036	45.8	49.5	40.69	-1.279E-06	7.771E-05	-2.629E+00
3037	47	(^e)	41.29	-1.279E-06	7.771E-05	-2.629E+00
3038	47.1	6.7	41.29	-1.279E-06	7.771E-05	-2.629E+00
3039	46.7	12.3	41.12	-1.279E-06	7.771E-05	-2.629E+00
3040	46.4	20.6	40.99	-1.279E-06	7.771E-05	-2.629E+00
3041	46.6	32.4	41.02	-1.279E-06	7.771E-05	-2.629E+00
3042	47.3	11.8	41.34	-1.279E-06	7.771E-05	-2.629E+00
3043	46.3	(^e)	41	-1.279E-06	7.771E-05	-2.629E+00
3044	44.9	(^e)	40.4	-1.279E-06	7.771E-05	-2.629E+00
3045	43.6	15.7	39.84	-1.279E-06	7.771E-05	-2.629E+00
3046	44	29.1	39.95	-1.279E-06	7.771E-05	-2.629E+00
3047	44.4	17.1	40.16	-1.279E-06	7.771E-05	-2.629E+00
3048	44.8	23	40.3	-1.279E-06	7.771E-05	-2.629E+00
3049	44.9	21.9	40.35	-1.279E-06	7.771E-05	-2.629E+00
3050	45.1	21.5	40.44	-1.279E-06	7.771E-05	-2.629E+00
3051	44.8	36.8	40.28	-1.279E-06	7.771E-05	-2.629E+00
3052	44.8	40	40.29	-1.279E-06	7.771E-05	-2.629E+00
3053	45.4	8.4	40.57	-1.279E-06	7.771E-05	-2.629E+00
3054	44.5	22.7	40.19	-1.279E-06	7.771E-05	-2.629E+00
3055	44	43	39.92	-1.279E-06	7.771E-05	-2.629E+00
3056	45.2	16.5	40.48	-1.279E-06	7.771E-05	-2.629E+00
3057	45.5	(^e)	40.62	-1.279E-06	7.771E-05	-2.629E+00
3058	45	4	40.43	-4.265E-07	2.590E-05	-8.763E-01
3059	47	12.5	41.24	4.265E-07	-2.590E-05	8.763E-01
3060	45.8	(^e)	40.82	1.279E-06	-7.771E-05	2.629E+00
3061	45.6	(^e)	40.72	1.279E-06	-7.771E-05	2.629E+00
3062	45.2	(^e)	40.56	1.279E-06	-7.771E-05	2.629E+00
3063	44.2	(^e)	40.13	1.279E-06	-7.771E-05	2.629E+00
3064	42.6	(^e)	39.45	1.279E-06	-7.771E-05	2.629E+00
3065	41.2	(^e)	38.88	1.279E-06	-7.771E-05	2.629E+00
3066	39.6	(^e)	38.22	1.279E-06	-7.771E-05	2.629E+00
3067	37.3	(^e)	37.22	1.279E-06	-7.771E-05	2.629E+00
3068	35.6	(^e)	36.53	1.279E-06	-7.771E-05	2.629E+00
3069	34.6	(^e)	36.11	1.279E-06	-7.771E-05	2.629E+00
3070	33.4	(^e)	35.63	1.279E-06	-7.771E-05	2.629E+00
3071	31.9	(^e)	34.99	1.279E-06	-7.771E-05	2.629E+00
3072	29.8	(^e)	34.12	1.279E-06	-7.771E-05	2.629E+00
3073	28.2	2.7	33.44	1.279E-06	-7.771E-05	2.629E+00
3074	28.7	25	33.59	1.279E-06	-7.771E-05	2.629E+00
3075	28	(^e)	33.36	1.279E-06	-7.771E-05	2.629E+00
3076	27.2	(^e)	33.07	1.279E-06	-7.771E-05	2.629E+00
3077	24.8	(^e)	32.09	1.279E-06	-7.771E-05	2.629E+00
3078	21.8	(^e)	30.8	1.279E-06	-7.771E-05	2.629E+00
3079	19.5	(^e)	29.84	1.279E-06	-7.771E-05	2.629E+00
3080	17.4	(^e)	28.96	1.279E-06	-7.771E-05	2.629E+00
3081	41.9	19.2	28.16	1.279E-06	-7.771E-05	2.629E+00
3082	38	(^e)	27.61	1.279E-06	-7.771E-05	2.629E+00
3083	35.2	(^e)	26.78	1.279E-06	-7.771E-05	2.629E+00
3084	31.2	(^e)	25.54	1.279E-06	-7.771E-05	2.629E+00
3085	27.6	3	24.41	1.279E-06	-7.771E-05	2.629E+00
3086	29.3	42.9	24.87	1.279E-06	-7.771E-05	2.629E+00
3087	29.7	38.8	24.98	1.279E-06	-7.771E-05	2.629E+00
3088	27	(^e)	24.23	1.279E-06	-7.771E-05	2.629E+00
3089	25.1	(^e)	23.7	1.279E-06	-7.771E-05	2.629E+00
3090	20	(^e)	22.18	1.279E-06	-7.771E-05	2.629E+00
3091	34.3	15.3	19.97	1.279E-06	-7.771E-05	2.629E+00

3092	25.8	(^e)	17.8	1.279E-06	-7.771E-05	2.629E+00
3093	22.1	(^e)	16.89	1.279E-06	-7.771E-05	2.629E+00
3094	20.7	(^e)	16.57	1.279E-06	-7.771E-05	2.629E+00
3095	19	(^e)	16.19	1.279E-06	-7.771E-05	2.629E+00
3096	34	17.2	15.05	1.279E-06	-7.771E-05	2.629E+00
3097	26.1	1.2	13.21	1.279E-06	-7.771E-05	2.629E+00
3098	11.7	7.9	8.67	1.279E-06	-7.771E-05	2.629E+00
3099	14.6	7.5	4.71	1.279E-06	-7.771E-05	2.629E+00
3100	2.1	0.3	2.23	1.279E-06	-7.771E-05	2.629E+00
3101	0.1	2.1	0.64	4.265E-07	-2.590E-05	8.763E-01
3102	0	0	0	-4.265E-07	2.590E-05	-8.763E-01
3103	0	0	0	-1.279E-06	7.771E-05	-2.629E+00
3124	0	0	0	-1.279E-06	7.771E-05	-2.629E+00
3125	0.6	10.4	0.19	-1.279E-06	7.771E-05	-2.629E+00
3126	7.6	32.5	1.28	-1.279E-06	7.771E-05	-2.629E+00
3127	14.8	14.4	2.8	-1.279E-06	7.771E-05	-2.629E+00
3128	33.9	8.5	3.61	-1.279E-06	7.771E-05	-2.629E+00
3129	57.6	11.5	4.62	-1.279E-06	7.771E-05	-2.629E+00
3130	66.3	12.2	5.82	-1.279E-06	7.771E-05	-2.629E+00
3131	71.7	30.5	6.74	-1.279E-06	7.771E-05	-2.629E+00
3132	44.1	5.8	8.12	-1.279E-06	7.771E-05	-2.629E+00
3133	53.4	37.5	9.38	-1.279E-06	7.771E-05	-2.629E+00
3134	106.1	78.9	13.44	-1.279E-06	7.771E-05	-2.629E+00
3135	43.8	1.9	13.76	-1.279E-06	7.771E-05	-2.629E+00
3136	60	59.6	16.08	-1.279E-06	7.771E-05	-2.629E+00
3137	90.4	70.2	20.49	-1.279E-06	7.771E-05	-2.629E+00
3138	62.1	1.8	20.87	-1.279E-06	7.771E-05	-2.629E+00
3139	71.3	61.6	22.66	-1.279E-06	7.771E-05	-2.629E+00
3140	85.2	26.5	25.16	-1.279E-06	7.771E-05	-2.629E+00
3141	54.6	20.2	25.48	-1.279E-06	7.771E-05	-2.629E+00
3142	64.1	71.4	27.67	-1.279E-06	7.771E-05	-2.629E+00
3143	76.1	46.3	30.65	-1.279E-06	7.771E-05	-2.629E+00
3144	51.8	0.8	31.12	-1.279E-06	7.771E-05	-2.629E+00
3145	50.9	(^e)	31.4	-1.279E-06	7.771E-05	-2.629E+00
3146	51.3	(^e)	31.52	-1.279E-06	7.771E-05	-2.629E+00
3147	51.6	(^e)	31.63	-1.279E-06	7.771E-05	-2.629E+00
3148	51.9	(^e)	31.73	-1.279E-06	7.771E-05	-2.629E+00
3149	51.9	(^e)	31.71	-1.279E-06	7.771E-05	-2.629E+00
3150	51.4	(^e)	31.57	-1.279E-06	7.771E-05	-2.629E+00
3151	50.2	(^e)	31.23	-1.279E-06	7.771E-05	-2.629E+00
3152	48.6	(^e)	30.73	-1.279E-06	7.771E-05	-2.629E+00
3153	47.3	(^e)	30.3	-1.279E-06	7.771E-05	-2.629E+00
3154	47.1	(^e)	30.21	-1.279E-06	7.771E-05	-2.629E+00
3155	47.9	4.9	30.46	-1.279E-06	7.771E-05	-2.629E+00
3156	49.6	14	30.96	-1.279E-06	7.771E-05	-2.629E+00
3157	52.5	26	31.86	-1.279E-06	7.771E-05	-2.629E+00
3158	54.8	14.1	32.6	-1.279E-06	7.771E-05	-2.629E+00
3159	56.1	5.8	33.02	-1.279E-06	7.771E-05	-2.629E+00
3160	57	3.4	33.28	-1.279E-06	7.771E-05	-2.629E+00
3161	57.9	5.5	33.57	-1.279E-06	7.771E-05	-2.629E+00
3162	58	7.5	33.87	-1.279E-06	7.771E-05	-2.629E+00
3163	34.6	(^e)	33.8	-1.279E-06	7.771E-05	-2.629E+00
3164	34.3	(^e)	33.67	-1.279E-06	7.771E-05	-2.629E+00
3165	34.2	20.5	33.61	-1.279E-06	7.771E-05	-2.629E+00
3166	34.8	25.1	33.83	-1.279E-06	7.771E-05	-2.629E+00
3167	35.3	24.8	34.04	-1.279E-06	7.771E-05	-2.629E+00
3168	36.1	30.5	34.35	-1.279E-06	7.771E-05	-2.629E+00
3169	37.2	32.4	34.77	-3.252E-07	-6.690E-04	-2.393E+00
3170	38.1	28.6	35.16	6.290E-07	-1.416E-03	-2.157E+00
3171	38.8	25.7	35.44	1.583E-06	-2.162E-03	-1.921E+00
3172	39.5	26.4	35.7	1.583E-06	-2.162E-03	-1.921E+00
3173	40.2	27	36	1.583E-06	-2.162E-03	-1.921E+00
3174	40.9	23.3	36.27	1.583E-06	-2.162E-03	-1.921E+00
3175	41.2	21.8	36.4	1.583E-06	-2.162E-03	-1.921E+00
3176	42	32.6	36.67	1.583E-06	-2.162E-03	-1.921E+00
3177	43.4	41.2	37.21	1.583E-06	-2.162E-03	-1.921E+00

3178	46.2	74.3	38.28	1.583E-06	-2.162E-03	-1.921E+00
3179	50.5	90.2	39.97	1.583E-06	-2.162E-03	-1.921E+00
3180	53.9	41.2	41.41	1.583E-06	-2.162E-03	-1.921E+00
3181	54.1	13.4	41.56	5.277E-07	-7.208E-04	-6.402E-01
3182	53.5	(^a)	41.33	-5.277E-07	7.208E-04	6.402E-01
3183	51.9	(^a)	40.72	-1.583E-06	2.162E-03	1.921E+00
3184	50.3	(^a)	40.07	-1.583E-06	2.162E-03	1.921E+00
3185	48.4	(^a)	39.34	-1.583E-06	2.162E-03	1.921E+00
3186	47	(^a)	38.75	-1.583E-06	2.162E-03	1.921E+00
3187	46	(^a)	38.34	-1.583E-06	2.162E-03	1.921E+00
3188	44.6	(^a)	37.79	-1.583E-06	2.162E-03	1.921E+00
3189	42.5	(^a)	37.02	-1.583E-06	2.162E-03	1.921E+00
3190	38.1	(^a)	35.28	-1.583E-06	2.162E-03	1.921E+00
3191	35.1	(^a)	34.03	-1.583E-06	2.162E-03	1.921E+00
3192	33	(^a)	33.19	-1.583E-06	2.162E-03	1.921E+00
3193	31.5	(^a)	32.55	-1.583E-06	2.162E-03	1.921E+00
3194	30.8	11.8	32.27	-1.583E-06	2.162E-03	1.921E+00
3195	30.8	15.6	32.23	-1.583E-06	2.162E-03	1.921E+00
3196	30.6	(^a)	32.19	-1.583E-06	2.162E-03	1.921E+00
3197	28	(^a)	31.26	-1.583E-06	2.162E-03	1.921E+00
3198	21.4	(^a)	28.69	-1.583E-06	2.162E-03	1.921E+00
3199	33.8	6	25.33	-1.583E-06	2.162E-03	1.921E+00
3200	20.7	(^a)	22.12	-1.583E-06	2.162E-03	1.921E+00
3201	32	8.3	19.64	-1.583E-06	2.162E-03	1.921E+00
3202	24	(^a)	18.09	-1.583E-06	2.162E-03	1.921E+00
3203	19.9	(^a)	17.06	-1.583E-06	2.162E-03	1.921E+00
3204	40.2	16.1	16.91	-1.583E-06	2.162E-03	1.921E+00
3205	43.3	26	17.48	-1.583E-06	2.162E-03	1.921E+00
3206	49.5	24.1	18.65	-1.583E-06	2.162E-03	1.921E+00
3207	52.6	16.2	19.24	-1.583E-06	2.162E-03	1.921E+00
3208	56.1	16.8	19.91	-1.583E-06	2.162E-03	1.921E+00
3209	57.4	1.5	20.18	-1.583E-06	2.162E-03	1.921E+00
3210	54.3	(^a)	19.61	-1.583E-06	2.162E-03	1.921E+00
3211	51	(^a)	18.99	-1.583E-06	2.162E-03	1.921E+00
3212	47.8	(^a)	18.39	-1.583E-06	2.162E-03	1.921E+00
3213	44.7	(^a)	17.8	-1.583E-06	2.162E-03	1.921E+00
3214	41	(^a)	17.12	-1.583E-06	2.162E-03	1.921E+00
3215	37.3	(^a)	16.42	-1.583E-06	2.162E-03	1.921E+00
3216	31.4	(^a)	15.33	-1.583E-06	2.162E-03	1.921E+00
3217	20.8	(^a)	13.35	-1.583E-06	2.162E-03	1.921E+00
3218	34.5	10.9	12.3	-1.583E-06	2.162E-03	1.921E+00
3219	29	(^a)	11.67	-1.583E-06	2.162E-03	1.921E+00
3220	22.3	(^a)	10.68	-1.583E-06	2.162E-03	1.921E+00
3221	13.8	(^a)	9.44	-1.583E-06	2.162E-03	1.921E+00
3222	21.9	6.8	8.17	-1.583E-06	2.162E-03	1.921E+00
3223	16.8	6.7	7.78	-1.583E-06	2.162E-03	1.921E+00
3224	18.1	12.5	7.93	-1.583E-06	2.162E-03	1.921E+00
3225	19.5	9.6	8.1	-1.583E-06	2.162E-03	1.921E+00
3226	20.9	10.3	8.26	-1.583E-06	2.162E-03	1.921E+00
3227	21.1	4.8	8.28	-1.583E-06	2.162E-03	1.921E+00
3228	16.2	(^a)	7.74	-1.583E-06	2.162E-03	1.921E+00
3229	19.6	9.3	6.1	-1.583E-06	2.162E-03	1.921E+00
3230	13.5	1.1	4.38	-1.583E-06	2.162E-03	1.921E+00
3231	18.2	(^a)	3.83	-1.583E-06	2.162E-03	1.921E+00
3232	13.9	6.2	3.58	-5.277E-07	7.208E-04	6.402E-01
3233	20.5	14.6	3.94	5.277E-07	-7.208E-04	-6.402E-01
3234	33.4	9.2	4.66	1.583E-06	-2.162E-03	-1.921E+00
3235	43.5	8	5.23	1.583E-06	-2.162E-03	-1.921E+00
3236	54.4	8.7	5.84	1.583E-06	-2.162E-03	-1.921E+00
3237	66.2	9.2	6.5	1.583E-06	-2.162E-03	-1.921E+00
3238	43.1	1	6.49	1.583E-06	-2.162E-03	-1.921E+00
3239	54	16.4	7.41	1.583E-06	-2.162E-03	-1.921E+00
3240	69.3	13.6	8.51	1.583E-06	-2.162E-03	-1.921E+00
3241	65.5	13.2	8.99	1.583E-06	-2.162E-03	-1.921E+00
3242	50	26.4	9.1	1.583E-06	-2.162E-03	-1.921E+00
3243	62.2	8.9	10.26	1.583E-06	-2.162E-03	-1.921E+00

3244	60.4	4.5	10.19	1.583E-06	-2.162E-03	-1.921E+00
3245	33.7	(°)	9.77	1.583E-06	-2.162E-03	-1.921E+00
3246	27.5	(°)	9.05	1.583E-06	-2.162E-03	-1.921E+00
3247	16.4	(°)	7.78	1.583E-06	-2.162E-03	-1.921E+00
3248	23.9	6.8	6.52	1.583E-06	-2.162E-03	-1.921E+00
3249	13.5	(°)	5.82	2.099E-06	-3.681E-03	-1.983E+00
3250	21.9	1	4.99	2.615E-06	-5.199E-03	-2.046E+00
3251	15.2	8.3	4.66	3.131E-06	-6.718E-03	-2.109E+00
3252	24.2	16.5	5.29	3.131E-06	-6.718E-03	-2.109E+00
3253	35.3	10.4	6.09	3.131E-06	-6.718E-03	-2.109E+00
3254	41.6	5.6	6.54	3.131E-06	-6.718E-03	-2.109E+00
3255	39.6	(°)	6.41	3.131E-06	-6.718E-03	-2.109E+00
3256	37.9	3.5	6.29	3.131E-06	-6.718E-03	-2.109E+00
3257	40.2	5.7	6.44	3.131E-06	-6.718E-03	-2.109E+00
3258	43.8	5.7	6.7	3.131E-06	-6.718E-03	-2.109E+00
3259	47	5.1	6.93	3.131E-06	-6.718E-03	-2.109E+00
3260	51.7	7.4	7.26	3.131E-06	-6.718E-03	-2.109E+00
3261	60.2	10.7	7.86	3.131E-06	-6.718E-03	-2.109E+00
3262	69.7	10	8.54	3.131E-06	-6.718E-03	-2.109E+00
3263	45	0.1	8.49	3.131E-06	-6.718E-03	-2.109E+00
3264	37	(°)	7.97	3.131E-06	-6.718E-03	-2.109E+00
3265	29.3	(°)	7.28	3.131E-06	-6.718E-03	-2.109E+00
3266	20.4	(°)	6.46	3.131E-06	-6.718E-03	-2.109E+00
3267	12.8	(°)	5.76	3.131E-06	-6.718E-03	-2.109E+00
3268	30.2	4.2	5.62	3.131E-06	-6.718E-03	-2.109E+00
3269	45.6	23.4	6.79	3.131E-06	-6.718E-03	-2.109E+00
3270	66.8	15.6	8.32	1.044E-06	-2.239E-03	-7.030E-01
3271	77.2	13.6	9.08	-1.044E-06	2.239E-03	7.030E-01
3272	48.2	2.2	8.93	-3.131E-06	6.718E-03	2.109E+00
3273	41.3	(°)	8.38	-3.131E-06	6.718E-03	2.109E+00
3274	33.5	(°)	7.66	-3.131E-06	6.718E-03	2.109E+00
3275	26	(°)	6.97	-3.131E-06	6.718E-03	2.109E+00
3276	18.7	(°)	6.3	-3.131E-06	6.718E-03	2.109E+00
3277	12.2	0.2	5.74	-3.131E-06	6.718E-03	2.109E+00
3278	20.9	(°)	4.92	-3.131E-06	6.718E-03	2.109E+00
3279	12.8	6.5	3.34	-3.131E-06	6.718E-03	2.109E+00
3280	0	0	0.54	-1.044E-06	2.239E-03	7.030E-01
3281	0	0	0	1.044E-06	-2.239E-03	-7.030E-01
3282	0	0	0	3.131E-06	-6.718E-03	-2.109E+00
3556	0	0	0	3.131E-06	-6.718E-03	-2.109E+00
3557	0.6	11.9	0	3.131E-06	-6.718E-03	-2.109E+00
3558	6.5	28.8	0.49	3.131E-06	-6.718E-03	-2.109E+00
3559	7.2	27	2	3.131E-06	-6.718E-03	-2.109E+00
3560	15.7	15	2.83	3.131E-06	-6.718E-03	-2.109E+00
3561	34.4	12.3	3.62	3.131E-06	-6.718E-03	-2.109E+00
3562	64.6	16.7	4.91	3.131E-06	-6.718E-03	-2.109E+00
3563	50.3	4.6	5.41	3.131E-06	-6.718E-03	-2.109E+00
3564	65.3	30.7	6.38	3.131E-06	-6.718E-03	-2.109E+00
3565	47.8	14.2	7.69	3.131E-06	-6.718E-03	-2.109E+00
3566	38.7	32.5	8.06	3.131E-06	-6.718E-03	-2.109E+00
3567	84.4	74.8	12.11	3.131E-06	-6.718E-03	-2.109E+00
3568	42.8	4.5	13.12	3.131E-06	-6.718E-03	-2.109E+00
3569	44	39.1	13.79	1.044E-06	-2.239E-03	-7.030E-01
3570	45.5	(°)	14.11	-1.044E-06	2.239E-03	7.030E-01
3571	39.2	(°)	13.18	-3.131E-06	6.718E-03	2.109E+00
3572	30.6	(°)	11.93	-3.131E-06	6.718E-03	2.109E+00
3573	13.5	0.7	9.43	-3.131E-06	6.718E-03	2.109E+00
3574	14.7	7.9	5.1	-3.131E-06	6.718E-03	2.109E+00
3575	1.2	(°)	2.51	-3.131E-06	6.718E-03	2.109E+00
3576	0.1	5.8	1.8	-1.044E-06	2.239E-03	7.030E-01
3577	4.1	10.8	1.74	1.044E-06	-2.239E-03	-7.030E-01
3578	6.8	10.2	2.16	3.131E-06	-6.718E-03	-2.109E+00
3579	5.3	4.6	2.17	3.131E-06	-6.718E-03	-2.109E+00
3580	0.9	5.4	2	3.131E-06	-6.718E-03	-2.109E+00
3581	0.3	10.6	2.03	3.131E-06	-6.718E-03	-2.109E+00
3582	6.1	12.3	2.12	3.131E-06	-6.718E-03	-2.109E+00

3583	14.3	15.2	2.77	3.131E-06	-6.718E-03	-2.109E+00
3584	27.3	8.3	3.33	3.131E-06	-6.718E-03	-2.109E+00
3585	33.1	3.6	3.59	3.131E-06	-6.718E-03	-2.109E+00
3586	31.1	2.5	3.51	3.131E-06	-6.718E-03	-2.109E+00
3587	33.3	5.1	3.59	3.131E-06	-6.718E-03	-2.109E+00
3588	40.7	5.2	3.91	3.131E-06	-6.718E-03	-2.109E+00
3589	43.5	2.3	4.04	3.131E-06	-6.718E-03	-2.109E+00
3590	38.6	1.8	3.83	3.131E-06	-6.718E-03	-2.109E+00
3591	44.8	6.7	4.09	3.131E-06	-6.718E-03	-2.109E+00
3592	57.6	8.2	4.63	3.131E-06	-6.718E-03	-2.109E+00
3593	49.5	10.2	4.96	3.131E-06	-6.718E-03	-2.109E+00
3594	44.3	16.7	5.26	3.131E-06	-6.718E-03	-2.109E+00
3595	73.3	20.3	6.86	3.131E-06	-6.718E-03	-2.109E+00
3596	46.1	13	7.63	3.131E-06	-6.718E-03	-2.109E+00
3597	38.4	32.8	8.03	3.131E-06	-6.718E-03	-2.109E+00
3598	75	46	11.34	3.131E-06	-6.718E-03	-2.109E+00
3599	48.3	13.8	12.5	3.131E-06	-6.718E-03	-2.109E+00
3600	36.9	36.6	12.76	3.131E-06	-6.718E-03	-2.109E+00
3601	59.4	72.6	15.98	3.131E-06	-6.718E-03	-2.109E+00
3602	82.2	57.1	19.37	3.131E-06	-6.718E-03	-2.109E+00
3603	59.9	2.7	20.07	3.131E-06	-6.718E-03	-2.109E+00
3604	60.4	43.6	20.65	1.044E-06	-2.239E-03	-7.030E-01
3605	59.8	(^c)	20.68	-1.044E-06	2.239E-03	7.030E-01
3606	47.9	(^c)	18.48	-3.131E-06	6.718E-03	2.109E+00
3607	35.5	(^c)	16.12	-3.131E-06	6.718E-03	2.109E+00
3608	26.5	(^c)	14.4	-3.131E-06	6.718E-03	2.109E+00
3609	21.3	(^c)	13.41	-3.131E-06	6.718E-03	2.109E+00
3610	33	7.2	11.79	-3.131E-06	6.718E-03	2.109E+00
3611	11.3	(^c)	9.06	-3.131E-06	6.718E-03	2.109E+00
3612	19.5	12.5	6.43	-3.131E-06	6.718E-03	2.109E+00
3613	13.9	(^c)	4.34	-3.131E-06	6.718E-03	2.109E+00
3614	0	0	2.11	-1.044E-06	2.239E-03	7.030E-01
3615	0	0	0	1.044E-06	-2.239E-03	-7.030E-01
3616	0	0	0	3.131E-06	-6.718E-03	-2.109E+00
3631	0	0	0	3.131E-06	-6.718E-03	-2.109E+00
3632	1.1	7.1	0	3.131E-06	-6.718E-03	-2.109E+00
3633	4.3	13.6	0.11	3.131E-06	-6.718E-03	-2.109E+00
3634	6.3	22.9	1.02	3.131E-06	-6.718E-03	-2.109E+00
3635	6.6	17	1.96	3.131E-06	-6.718E-03	-2.109E+00
3636	6.4	9.9	2.33	3.131E-06	-6.718E-03	-2.109E+00
3637	7.9	9.9	2.5	3.131E-06	-6.718E-03	-2.109E+00
3638	15.2	14	2.81	3.131E-06	-6.718E-03	-2.109E+00
3639	31.5	9.6	3.51	3.131E-06	-6.718E-03	-2.109E+00
3640	46.2	8.1	4.14	3.131E-06	-6.718E-03	-2.109E+00
3641	68.3	14.2	5.08	3.131E-06	-6.718E-03	-2.109E+00
3642	44.3	1.2	5.14	3.131E-06	-6.718E-03	-2.109E+00
3643	75.6	38.8	6.93	3.131E-06	-6.718E-03	-2.109E+00
3644	46	8.5	8.06	3.131E-06	-6.718E-03	-2.109E+00
3645	45	33.7	8.63	3.131E-06	-6.718E-03	-2.109E+00
3646	89.9	66.8	12.65	3.131E-06	-6.718E-03	-2.109E+00
3647	40.7	0.4	13.06	3.131E-06	-6.718E-03	-2.109E+00
3648	46	48	14.06	3.131E-06	-6.718E-03	-2.109E+00
3649	72.2	82.4	17.83	3.131E-06	-6.718E-03	-2.109E+00
3650	75.6	17.4	20.25	3.131E-06	-6.718E-03	-2.109E+00
3651	58.3	36	20.27	3.131E-06	-6.718E-03	-2.109E+00
3652	71.6	75	22.69	3.131E-06	-6.718E-03	-2.109E+00
3653	83.1	25.7	24.95	3.131E-06	-6.718E-03	-2.109E+00
3654	51.8	20.3	24.78	3.131E-06	-6.718E-03	-2.109E+00
3655	59.3	70.8	26.5	3.131E-06	-6.718E-03	-2.109E+00
3656	70.7	80.1	29.27	3.131E-06	-6.718E-03	-2.109E+00
3657	76.9	26.6	30.86	3.131E-06	-6.718E-03	-2.109E+00
3658	49.2	2.5	30.59	3.131E-06	-6.718E-03	-2.109E+00
3659	49.7	15.4	31	1.044E-06	-2.239E-03	-7.030E-01
3660	49.1	(^c)	30.84	-1.044E-06	2.239E-03	7.030E-01
3661	47.5	(^c)	30.33	-3.131E-06	6.718E-03	2.109E+00
3662	46.3	(^c)	29.98	-3.131E-06	6.718E-03	2.109E+00

3663	44	(°)	29.27	-3.131E-06	6.718E-03	2.109E+00
3664	39.4	(°)	27.91	-3.131E-06	6.718E-03	2.109E+00
3665	33.2	(°)	25.96	-3.131E-06	6.718E-03	2.109E+00
3666	28.7	(°)	24.56	-3.131E-06	6.718E-03	2.109E+00
3667	23.1	(°)	22.84	-3.131E-06	6.718E-03	2.109E+00
3668	33.7	13.1	20.96	-3.131E-06	6.718E-03	2.109E+00
3669	30.5	(°)	19.66	-3.131E-06	6.718E-03	2.109E+00
3670	24.9	(°)	18.32	-3.131E-06	6.718E-03	2.109E+00
3671	28.2	13.5	15.79	-3.131E-06	6.718E-03	2.109E+00
3672	22.4	4.6	12.51	-3.131E-06	6.718E-03	2.109E+00
3673	16.2	2.1	9.73	-3.131E-06	6.718E-03	2.109E+00
3674	16.5	5.1	7.5	-3.131E-06	6.718E-03	2.109E+00
3675	14	7.2	5.34	-3.131E-06	6.718E-03	2.109E+00
3676	13.5	5.4	3.39	-3.131E-06	6.718E-03	2.109E+00
3677	0	0	2.14	-3.131E-06	6.718E-03	2.109E+00
3678	0	0	0.73	-1.044E-06	2.239E-03	7.030E-01
3679	0	0	0	1.044E-06	-2.239E-03	-7.030E-01
3680	0	0	0	3.131E-06	-6.718E-03	-2.109E+00
3681	0	0	0	3.131E-06	-6.718E-03	-2.109E+00
3682	6	24.4	0.26	3.131E-06	-6.718E-03	-2.109E+00
3683	7.7	33.4	2.05	3.131E-06	-6.718E-03	-2.109E+00
3684	25.5	15.4	3.24	3.131E-06	-6.718E-03	-2.109E+00
3685	50.1	13	4.29	3.131E-06	-6.718E-03	-2.109E+00
3686	77	16.7	5.45	3.131E-06	-6.718E-03	-2.109E+00
3687	45.5	1.1	5.36	3.131E-06	-6.718E-03	-2.109E+00
3688	96	52.9	7.76	3.131E-06	-6.718E-03	-2.109E+00
3689	34.5	2.6	7.59	3.131E-06	-6.718E-03	-2.109E+00
3690	59.4	53.3	9.89	3.131E-06	-6.718E-03	-2.109E+00
3691	89.5	33.2	13.3	3.131E-06	-6.718E-03	-2.109E+00
3692	39.2	2	13.14	3.131E-06	-6.718E-03	-2.109E+00
3693	56.1	63.8	15.5	3.131E-06	-6.718E-03	-2.109E+00
3694	83.3	70	19.5	3.131E-06	-6.718E-03	-2.109E+00
3695	59.2	0.3	20.13	3.131E-06	-6.718E-03	-2.109E+00
3696	61.6	50.6	20.86	3.131E-06	-6.718E-03	-2.109E+00
3697	77.6	83.9	23.79	3.131E-06	-6.718E-03	-2.109E+00
3698	57.3	6	24.88	3.131E-06	-6.718E-03	-2.109E+00
3699	53.5	43.8	25.15	3.131E-06	-6.718E-03	-2.109E+00
3700	62.9	79.6	27.36	3.131E-06	-6.718E-03	-2.109E+00
3701	75	95.3	30.28	3.131E-06	-6.718E-03	-2.109E+00
3702	53.6	4.6	31.04	3.131E-06	-6.718E-03	-2.109E+00
3703	50.6	46.1	31.22	3.131E-06	-6.718E-03	-2.109E+00
3704	56.4	79.9	32.96	3.131E-06	-6.718E-03	-2.109E+00
3705	64	93.9	35.29	3.131E-06	-6.718E-03	-2.109E+00
3706	69.6	37.6	37.14	3.131E-06	-6.718E-03	-2.109E+00
3707	70.6	21.5	37.49	3.131E-06	-6.718E-03	-2.109E+00
3708	68	11.4	37.47	3.131E-06	-6.718E-03	-2.109E+00
3709	43	12.2	37.14	3.131E-06	-6.718E-03	-2.109E+00
3710	44.5	29.6	37.67	3.131E-06	-6.718E-03	-2.109E+00
3711	44.4	10.1	37.68	1.044E-06	-2.239E-03	-7.030E-01
3712	44	7	37.52	-1.044E-06	2.239E-03	7.030E-01
3713	43.1	2	37.2	-3.131E-06	6.718E-03	2.109E+00
3714	42.3	1.1	36.88	-3.131E-06	6.718E-03	2.109E+00
3715	41.2	(°)	36.45	-3.131E-06	6.718E-03	2.109E+00
3716	40	(°)	35.98	-3.131E-06	6.718E-03	2.109E+00
3717	38.7	(°)	35.45	-3.131E-06	6.718E-03	2.109E+00
3718	37.5	(°)	34.98	-3.131E-06	6.718E-03	2.109E+00
3719	36	(°)	34.35	-3.131E-06	6.718E-03	2.109E+00
3720	34.9	(°)	33.94	-3.131E-06	6.718E-03	2.109E+00
3721	32.8	(°)	33.13	-3.131E-06	6.718E-03	2.109E+00
3722	29.5	(°)	31.82	-3.131E-06	6.718E-03	2.109E+00
3723	25.9	(°)	30.38	-3.131E-06	6.718E-03	2.109E+00
3724	22.6	(°)	29.06	-3.131E-06	6.718E-03	2.109E+00
3725	19.9	(°)	27.94	-3.131E-06	6.718E-03	2.109E+00
3726	37	7.2	27.13	-3.131E-06	6.718E-03	2.109E+00
3727	32.7	(°)	25.82	-3.131E-06	6.718E-03	2.109E+00
3728	25.5	(°)	23.6	-3.131E-06	6.718E-03	2.109E+00

3729	19.6	4.9	21.48	-3.131E-06	6.718E-03	2.109E+00
3730	31.1	(°)	19.84	-3.131E-06	6.718E-03	2.109E+00
3731	25.9	(°)	18.54	-3.131E-06	6.718E-03	2.109E+00
3732	22.1	(°)	17.61	-3.131E-06	6.718E-03	2.109E+00
3733	36.9	12.8	16.17	-3.131E-06	6.718E-03	2.109E+00
3734	23.5	(°)	13.88	-3.131E-06	6.718E-03	2.109E+00
3735	30.2	6.8	11.44	-3.131E-06	6.718E-03	2.109E+00
3736	15.8	(°)	9.74	-3.131E-06	6.718E-03	2.109E+00
3737	22.3	3.5	8.06	-3.131E-06	6.718E-03	2.109E+00
3738	19.3	15.3	6.77	-3.131E-06	6.718E-03	2.109E+00
3739	15.8	9.3	5.41	-3.131E-06	6.718E-03	2.109E+00
3740	16.9	8.5	4.04	-3.131E-06	6.718E-03	2.109E+00
3741	0	0	2.53	-3.131E-06	6.718E-03	2.109E+00
3742	0	0	1.29	-1.044E-06	2.239E-03	7.030E-01
3743	0	0	0	1.044E-06	-2.239E-03	-7.030E-01
3744	1.7	9.1	0.06	3.131E-06	-6.718E-03	-2.109E+00
3745	7.1	31.5	1.17	3.131E-06	-6.718E-03	-2.109E+00
3746	10.3	21.5	2.59	3.131E-06	-6.718E-03	-2.109E+00
3747	43	17.4	3.98	3.131E-06	-6.718E-03	-2.109E+00
3748	89.3	31.2	5.76	3.131E-06	-6.718E-03	-2.109E+00
3749	52.3	1.8	5.74	3.131E-06	-6.718E-03	-2.109E+00
3750	101.6	65.3	8.02	3.131E-06	-6.718E-03	-2.109E+00
3751	38	1.8	7.95	3.131E-06	-6.718E-03	-2.109E+00
3752	65.1	55.2	10.4	3.131E-06	-6.718E-03	-2.109E+00
3753	78.5	29.8	13.35	3.131E-06	-6.718E-03	-2.109E+00
3754	40.6	15.2	13.34	3.131E-06	-6.718E-03	-2.109E+00
3755	60.4	67.5	16.13	3.131E-06	-6.718E-03	-2.109E+00
3756	90	70.2	20.44	3.131E-06	-6.718E-03	-2.109E+00
3757	60.3	2.3	20.41	3.131E-06	-6.718E-03	-2.109E+00
3758	66.9	60.6	21.82	3.131E-06	-6.718E-03	-2.109E+00
3759	79.2	30	24.21	3.131E-06	-6.718E-03	-2.109E+00
3760	51.3	1.2	24.25	3.131E-06	-6.718E-03	-2.109E+00
3761	53.4	47.7	25.13	3.131E-06	-6.718E-03	-2.109E+00
3762	55.7	8.4	25.76	3.131E-06	-6.718E-03	-2.109E+00
3763	55.4	(°)	25.7	3.131E-06	-6.718E-03	-2.109E+00
3764	54.3	1.4	25.43	3.131E-06	-6.718E-03	-2.109E+00
3765	53.9	4.1	25.33	3.131E-06	-6.718E-03	-2.109E+00
3766	54.1	9.3	25.38	3.131E-06	-6.718E-03	-2.109E+00
3767	55.6	18.5	25.7	3.131E-06	-6.718E-03	-2.109E+00
3768	59.3	36.6	26.57	3.131E-06	-6.718E-03	-2.109E+00
3769	63.8	30.1	27.69	3.131E-06	-6.718E-03	-2.109E+00
3770	66.4	18.2	28.36	3.131E-06	-6.718E-03	-2.109E+00
3771	43.1	0.4	28.38	3.131E-06	-6.718E-03	-2.109E+00
3772	43	51.1	28.85	3.131E-06	-6.718E-03	-2.109E+00
3773	49.6	81	30.82	3.131E-06	-6.718E-03	-2.109E+00
3774	55.1	49	32.61	-4.060E-06	-1.596E-03	-2.202E+00
3775	58.9	44.6	33.79	-1.125E-05	3.526E-03	-2.294E+00
3776	62.5	46.7	34.91	-1.844E-05	8.648E-03	-2.387E+00
3777	64.9	25.7	35.71	-1.844E-05	8.648E-03	-2.387E+00
3778	65.7	13.7	35.98	-1.844E-05	8.648E-03	-2.387E+00
3779	41.7	0.4	35.85	-1.844E-05	8.648E-03	-2.387E+00
3780	40.5	31.8	36.07	-1.844E-05	8.648E-03	-2.387E+00
3781	41.2	21	36.4	-1.844E-05	8.648E-03	-2.387E+00
3782	41.2	7.1	36.43	-1.844E-05	8.648E-03	-2.387E+00
3783	41.2	11.4	36.39	-1.844E-05	8.648E-03	-2.387E+00
3784	41.6	20.9	36.54	-1.844E-05	8.648E-03	-2.387E+00
3785	42.2	21.1	36.79	-1.844E-05	8.648E-03	-2.387E+00
3786	42.8	19.8	37.01	-1.844E-05	8.648E-03	-2.387E+00
3787	43.8	30.5	37.39	-1.844E-05	8.648E-03	-2.387E+00
3788	44.4	17.7	37.66	-1.844E-05	8.648E-03	-2.387E+00
3789	45.2	27.6	37.98	-1.844E-05	8.648E-03	-2.387E+00
3790	45.7	16.6	38.18	-1.844E-05	8.648E-03	-2.387E+00
3791	46.7	31.9	38.56	-1.844E-05	8.648E-03	-2.387E+00
3792	47.7	27.1	38.96	-1.844E-05	8.648E-03	-2.387E+00
3793	49.1	37.5	39.52	-1.844E-05	8.648E-03	-2.387E+00
3794	50.8	40.8	40.19	-1.844E-05	8.648E-03	-2.387E+00

3795	52.7	45.9	40.94	-1.844E-05	8.648E-03	-2.387E+00
3796	54.7	44.6	41.74	-1.844E-05	8.648E-03	-2.387E+00
3797	56.7	46.3	42.52	-1.844E-05	8.648E-03	-2.387E+00
3798	58.9	52.6	43.37	-1.844E-05	8.648E-03	-2.387E+00
3799	60.1	16.2	43.94	-1.844E-05	8.648E-03	-2.387E+00
3800	58	(^e)	43.21	-1.844E-05	8.648E-03	-2.387E+00
3801	34.9	(^e)	42.38	-1.844E-05	8.648E-03	-2.387E+00
3802	32.8	3.8	41.99	-1.844E-05	8.648E-03	-2.387E+00
3803	32.2	(^e)	41.68	-1.844E-05	8.648E-03	-2.387E+00
3804	31.2	(^e)	41.2	-1.844E-05	8.648E-03	-2.387E+00
3805	29.8	(^e)	40.52	-1.844E-05	8.648E-03	-2.387E+00
3806	28.7	(^e)	39.92	-1.844E-05	8.648E-03	-2.387E+00
3807	27.3	(^e)	39.25	-1.844E-05	8.648E-03	-2.387E+00
3808	25.7	(^e)	38.45	-1.844E-05	8.648E-03	-2.387E+00
3809	24.9	(^e)	37.98	-1.844E-05	8.648E-03	-2.387E+00
3810	23.7	(^e)	37.42	-1.844E-05	8.648E-03	-2.387E+00
3811	22.7	(^e)	36.9	-1.844E-05	8.648E-03	-2.387E+00
3812	21.9	(^e)	36.47	-1.844E-05	8.648E-03	-2.387E+00
3813	20.7	(^e)	35.88	-1.844E-05	8.648E-03	-2.387E+00
3814	19.4	(^e)	35.48	-1.844E-05	8.648E-03	-2.387E+00
3815	38.2	1.1	35.24	-1.844E-05	8.648E-03	-2.387E+00
3816	38.1	22.8	35.17	-1.844E-05	8.648E-03	-2.387E+00
3817	39.7	39.3	35.76	-1.844E-05	8.648E-03	-2.387E+00
3818	41.4	29.7	36.43	-1.844E-05	8.648E-03	-2.387E+00
3819	41.8	14.7	36.65	-1.342E-05	6.645E-03	-2.027E+00
3820	41.9	12.7	36.69	-8.405E-06	4.643E-03	-1.667E+00
3821	42.2	21.3	36.77	-3.386E-06	2.640E-03	-1.307E+00
3822	43.4	31.2	37.26	-3.386E-06	2.640E-03	-1.307E+00
3823	44.2	21	37.59	-3.386E-06	2.640E-03	-1.307E+00
3824	44.7	18.6	37.78	-3.386E-06	2.640E-03	-1.307E+00
3825	45.1	17.6	37.96	-3.386E-06	2.640E-03	-1.307E+00
3826	45.4	16.8	38.05	-3.386E-06	2.640E-03	-1.307E+00
3827	45.9	18.5	38.25	-3.386E-06	2.640E-03	-1.307E+00
3828	46	13	38.32	-3.386E-06	2.640E-03	-1.307E+00
3829	46	14.4	38.33	-3.386E-06	2.640E-03	-1.307E+00
3830	46.4	10.9	38.46	-3.386E-06	2.640E-03	-1.307E+00
3831	45.5	(^e)	38.15	-3.386E-06	2.640E-03	-1.307E+00
3832	44.4	(^e)	37.72	-3.386E-06	2.640E-03	-1.307E+00
3833	42.8	(^e)	37.08	-3.386E-06	2.640E-03	-1.307E+00
3834	41.1	(^e)	36.43	-3.386E-06	2.640E-03	-1.307E+00
3835	39.2	(^e)	35.66	-3.386E-06	2.640E-03	-1.307E+00
3836	38.1	(^e)	35.2	-3.386E-06	2.640E-03	-1.307E+00
3837	37.9	10.9	35.1	-3.386E-06	2.640E-03	-1.307E+00
3838	37.9	12.9	35.1	-3.386E-06	2.640E-03	-1.307E+00
3839	38.3	17.9	35.22	-3.386E-06	2.640E-03	-1.307E+00
3840	38.7	8.5	35.4	-3.386E-06	2.640E-03	-1.307E+00
3841	37.6	(^e)	35.02	-3.386E-06	2.640E-03	-1.307E+00
3842	37.6	14.5	34.95	-3.386E-06	2.640E-03	-1.307E+00
3843	37.5	8.5	34.93	-3.386E-06	2.640E-03	-1.307E+00
3844	37.4	7.6	34.88	-3.386E-06	2.640E-03	-1.307E+00
3845	36.9	5.2	34.72	-3.386E-06	2.640E-03	-1.307E+00
3846	36.9	13.2	34.69	-3.386E-06	2.640E-03	-1.307E+00
3847	37.2	13.9	34.8	-3.386E-06	2.640E-03	-1.307E+00
3848	37	6.9	34.75	-3.386E-06	2.640E-03	-1.307E+00
3849	36.8	2.4	34.65	-3.386E-06	2.640E-03	-1.307E+00
3850	35.8	(^e)	34.27	-3.386E-06	2.640E-03	-1.307E+00
3851	35.2	3.1	34.02	-3.386E-06	2.640E-03	-1.307E+00
3852	34.6	2.3	33.78	-3.386E-06	2.640E-03	-1.307E+00
3853	34.4	10.4	33.7	-3.386E-06	2.640E-03	-1.307E+00
3854	34.5	10.5	33.71	-3.386E-06	2.640E-03	-1.307E+00
3855	34.3	6.5	33.64	-3.386E-06	2.640E-03	-1.307E+00
3856	34	4.6	33.52	-3.386E-06	2.640E-03	-1.307E+00
3857	33.5	6	33.34	-3.386E-06	2.640E-03	-1.307E+00
3858	33.8	20.3	33.42	-3.386E-06	2.640E-03	-1.307E+00
3859	34.7	28.4	33.77	-3.386E-06	2.640E-03	-1.307E+00
3860	35.8	31.3	34.24	-3.386E-06	2.640E-03	-1.307E+00

3861	37.2	29.8	34.76	-3.386E-06	2.640E-03	-1.307E+00
3862	37.8	18.2	35.05	-3.386E-06	2.640E-03	-1.307E+00
3863	38.1	14.9	35.16	-3.386E-06	2.640E-03	-1.307E+00
3864	38.4	11.4	35.28	-3.386E-06	2.640E-03	-1.307E+00
3865	37.6	(^e)	35.01	-3.386E-06	2.640E-03	-1.307E+00
3866	37.1	1.7	34.79	-3.386E-06	2.640E-03	-1.307E+00
3867	36.2	(^e)	34.42	-3.386E-06	2.640E-03	-1.307E+00
3868	35.2	(^e)	34.03	-3.386E-06	2.640E-03	-1.307E+00
3869	34.4	(^e)	33.69	-3.386E-06	2.640E-03	-1.307E+00
3870	34.1	10.8	33.59	-3.386E-06	2.640E-03	-1.307E+00
3871	34.3	14.3	33.65	-3.386E-06	2.640E-03	-1.307E+00
3872	34.5	13.3	33.72	-3.386E-06	2.640E-03	-1.307E+00
3873	34.6	12.7	33.78	-3.386E-06	2.640E-03	-1.307E+00
3874	34.7	12.1	33.8	-3.386E-06	2.640E-03	-1.307E+00
3875	34.9	19.8	33.88	-3.386E-06	2.640E-03	-1.307E+00
3876	36.2	30.9	34.36	-3.386E-06	2.640E-03	-1.307E+00
3877	36.6	15.7	34.57	-3.386E-06	2.640E-03	-1.307E+00
3878	37.1	13.5	34.77	-1.129E-06	8.799E-04	-4.358E-01
3879	36.2	(^e)	34.44	1.129E-06	-8.799E-04	4.358E-01
3880	33.1	(^e)	33.26	3.386E-06	-2.640E-03	1.307E+00
3881	29	(^e)	31.65	3.386E-06	-2.640E-03	1.307E+00
3882	24.8	(^e)	29.96	3.386E-06	-2.640E-03	1.307E+00
3883	21.1	(^e)	28.47	3.386E-06	-2.640E-03	1.307E+00
3884	38.5	15.7	27.48	3.386E-06	-2.640E-03	1.307E+00
3885	35.8	(^e)	26.73	3.386E-06	-2.640E-03	1.307E+00
3886	33.7	(^e)	26.07	3.386E-06	-2.640E-03	1.307E+00
3887	30.7	(^e)	25.15	3.386E-06	-2.640E-03	1.307E+00
3888	27.3	(^e)	24.1	3.386E-06	-2.640E-03	1.307E+00
3889	26.6	13.3	23.83	3.386E-06	-2.640E-03	1.307E+00
3890	27.9	30.6	24.19	3.386E-06	-2.640E-03	1.307E+00
3891	30.7	41.6	25.07	3.386E-06	-2.640E-03	1.307E+00
3892	32.5	15.8	25.65	3.386E-06	-2.640E-03	1.307E+00
3893	31.9	(^e)	25.51	3.386E-06	-2.640E-03	1.307E+00
3894	21.8	(^e)	22.52	3.386E-06	-2.640E-03	1.307E+00
3895	25.6	4.2	17.98	3.386E-06	-2.640E-03	1.307E+00
3896	26.8	3.8	14.07	3.386E-06	-2.640E-03	1.307E+00
3897	20.2	2.5	10.09	3.386E-06	-2.640E-03	1.307E+00
3898	14.3	2.8	5.72	3.386E-06	-2.640E-03	1.307E+00
3899	11.3	6.7	3.24	3.386E-06	-2.640E-03	1.307E+00
3900	0	0	0.61	3.386E-06	-2.640E-03	1.307E+00
3901	0	0	0	3.386E-06	-2.640E-03	1.307E+00
3906	0	0	0	3.386E-06	-2.640E-03	1.307E+00
3907	0	0	0	6.559E-06	-6.283E-03	3.321E+00
3908	0	0	0	9.732E-06	-9.925E-03	5.334E+00
3909	0	0	0	1.291E-05	-1.357E-02	7.347E+00
3918	0	0	0	1.291E-05	-1.357E-02	7.347E+00
3919	3	5	0	1.291E-05	-1.357E-02	7.347E+00
3920	7	10	0	1.291E-05	-1.357E-02	7.347E+00
3921	6.7	32.8	0.66	1.291E-05	-1.357E-02	7.347E+00
3922	6.3	35	1.59	1.291E-05	-1.357E-02	7.347E+00
3923	5.8	25.2	2.33	1.291E-05	-1.357E-02	7.347E+00
3924	6.1	10.4	2.69	1.291E-05	-1.357E-02	7.347E+00
3925	0	0	2.52	1.291E-05	-1.357E-02	7.347E+00
3926	0.1	5.8	1.77	1.291E-05	-1.357E-02	7.347E+00
3927	0	0	0.66	1.291E-05	-1.357E-02	7.347E+00
3928	0	0	0	1.291E-05	-1.357E-02	7.347E+00
3929	0	0	0	1.291E-05	-1.357E-02	7.347E+00
3930	1.3	9.6	0	1.291E-05	-1.357E-02	7.347E+00
3931	6.3	36.6	0.32	1.291E-05	-1.357E-02	7.347E+00
3932	6.5	48.5	1.27	1.291E-05	-1.357E-02	7.347E+00
3933	5.9	38.4	2.24	1.291E-05	-1.357E-02	7.347E+00
3934	9.7	20.5	2.84	1.291E-05	-1.357E-02	7.347E+00
3935	17.5	14.9	3.17	1.291E-05	-1.357E-02	7.347E+00
3936	22.2	9	3.37	1.291E-05	-1.357E-02	7.347E+00
3937	22.6	4.6	3.39	1.291E-05	-1.357E-02	7.347E+00
3938	17.2	3.2	3.16	1.291E-05	-1.357E-02	7.347E+00

3939	10.7	(°)	2.89	1.291E-05	-1.357E-02	7.347E+00
3940	0	0	2.72	1.291E-05	-1.357E-02	7.347E+00
3941	0	0	2.11	1.291E-05	-1.357E-02	7.347E+00
3942	0	0	1.33	1.291E-05	-1.357E-02	7.347E+00
3943	0	0	0.85	1.291E-05	-1.357E-02	7.347E+00
3944	0	0	0.42	1.291E-05	-1.357E-02	7.347E+00
3945	0	0	0	1.291E-05	-1.357E-02	7.347E+00
4069	0	0	0	1.291E-05	-1.357E-02	7.347E+00
4070	1.2	9.5	0	1.291E-05	-1.357E-02	7.347E+00
4071	5.2	20.5	0.02	1.291E-05	-1.357E-02	7.347E+00
4072	5	20.8	0.43	1.291E-05	-1.357E-02	7.347E+00
4073	5.4	23.1	0.8	1.291E-05	-1.357E-02	7.347E+00
4074	5.1	18.1	1.22	1.291E-05	-1.357E-02	7.347E+00
4075	4.3	8.7	1.37	1.291E-05	-1.357E-02	7.347E+00
4076	0	0	1.34	1.291E-05	-1.357E-02	7.347E+00
4077	0	0	1.03	1.291E-05	-1.357E-02	7.347E+00
4078	0.8	6.4	0.65	1.291E-05	-1.357E-02	7.347E+00
4079	5.3	18.7	0.3	1.291E-05	-1.357E-02	7.347E+00
4080	4.8	19.6	0.26	1.291E-05	-1.357E-02	7.347E+00
4081	5.5	29.5	0.31	1.291E-05	-1.357E-02	7.347E+00
4082	6	38.2	0.92	1.291E-05	-1.357E-02	7.347E+00
4083	4.3	14.8	1.84	1.291E-05	-1.357E-02	7.347E+00
4084	4.3	8.7	1.92	1.291E-05	-1.357E-02	7.347E+00
4085	0.1	7.5	2.03	1.291E-05	-1.357E-02	7.347E+00
4086	0.1	5.9	2.46	1.291E-05	-1.357E-02	7.347E+00
4087	0.7	5.8	2.47	1.291E-05	-1.357E-02	7.347E+00
4088	0	0	2.68	1.291E-05	-1.357E-02	7.347E+00
4089	0	0	2.3	1.291E-05	-1.357E-02	7.347E+00
4090	0	0	1.2	1.291E-05	-1.357E-02	7.347E+00
4091	0	0	0.41	1.291E-05	-1.357E-02	7.347E+00
4092	0	0	0	1.291E-05	-1.357E-02	7.347E+00
4099	0	0	0	1.291E-05	-1.357E-02	7.347E+00
4100	0	0	0	1.174E-05	-1.229E-02	6.551E+00
4101	0	0	0	1.057E-05	-1.102E-02	5.754E+00
4102	0	0	0	9.395E-06	-9.748E-03	4.957E+00
4107	0	0	0	9.395E-06	-9.748E-03	4.957E+00
4108	0.9	5.4	0	9.395E-06	-9.748E-03	4.957E+00
4109	0.5	5.7	0	9.395E-06	-9.748E-03	4.957E+00
4110	0	0	0	9.395E-06	-9.748E-03	4.957E+00
4113	0	0	0	9.395E-06	-9.748E-03	4.957E+00
4114	0.3	10	0	9.395E-06	-9.748E-03	4.957E+00
4115	1.1	9.9	0	9.395E-06	-9.748E-03	4.957E+00
4116	1.6	9.7	0	9.395E-06	-9.748E-03	4.957E+00
4117	2.8	9.3	0	9.395E-06	-9.748E-03	4.957E+00
4118	2.3	9	0	9.395E-06	-9.748E-03	4.957E+00
4119	0.8	9.8	0	9.395E-06	-9.748E-03	4.957E+00
4120	1.4	9.6	0	9.395E-06	-9.748E-03	4.957E+00
4121	4.6	14	0.05	9.395E-06	-9.748E-03	4.957E+00
4122	4.5	13.1	0.2	9.395E-06	-9.748E-03	4.957E+00
4123	4.8	16	0.38	9.395E-06	-9.748E-03	4.957E+00
4124	5.1	18.8	0.54	9.395E-06	-9.748E-03	4.957E+00
4125	6	31.2	0.73	9.395E-06	-9.748E-03	4.957E+00
4126	7.1	52.5	1.23	9.395E-06	-9.748E-03	4.957E+00
4127	6	46	2.1	9.395E-06	-9.748E-03	4.957E+00
4128	9.5	25.5	2.83	9.395E-06	-9.748E-03	4.957E+00
4129	21.1	18.5	3.31	9.395E-06	-9.748E-03	4.957E+00
4130	32.1	12.2	3.78	9.395E-06	-9.748E-03	4.957E+00
4131	42	7.6	4.19	9.395E-06	-9.748E-03	4.957E+00
4132	48	9.1	4.44	9.395E-06	-9.748E-03	4.957E+00
4133	55.9	9.4	4.77	9.395E-06	-9.748E-03	4.957E+00
4134	33.8	14.3	4.64	9.395E-06	-9.748E-03	4.957E+00
4135	21.5	25	4.56	9.395E-06	-9.748E-03	4.957E+00
4136	24.7	9.1	4.75	9.395E-06	-9.748E-03	4.957E+00
4137	25.5	4.5	4.8	9.395E-06	-9.748E-03	4.957E+00
4138	28.7	9.9	4.98	9.395E-06	-9.748E-03	4.957E+00
4139	34.4	10.7	5.31	9.395E-06	-9.748E-03	4.957E+00

4140	40.5	4.7	5.65	9.395E-06	-9.748E-03	4.957E+00
4141	42.8	3.3	5.79	9.395E-06	-9.748E-03	4.957E+00
4142	43.4	0	5.82	9.395E-06	-9.748E-03	4.957E+00
4143	39.5	(°)	5.61	9.395E-06	-9.748E-03	4.957E+00
4144	34.1	(°)	5.3	9.395E-06	-9.748E-03	4.957E+00
4145	22	(°)	4.62	9.395E-06	-9.748E-03	4.957E+00
4146	0	0	2.84	9.395E-06	-9.748E-03	4.957E+00
4147	0	0	1.03	9.395E-06	-9.748E-03	4.957E+00
4148	0	0	0.44	9.395E-06	-9.748E-03	4.957E+00
4149	1.1	10.1	0.44	9.395E-06	-9.748E-03	4.957E+00
4150	7.2	38.5	1.04	9.395E-06	-9.748E-03	4.957E+00
4151	6.5	34.3	2.07	9.395E-06	-9.748E-03	4.957E+00
4152	6.2	18	2.69	9.395E-06	-9.748E-03	4.957E+00
4153	13.3	18.5	2.99	9.395E-06	-9.748E-03	4.957E+00
4154	21.3	13.1	3.32	9.395E-06	-9.748E-03	4.957E+00
4155	25.8	8.2	3.52	9.395E-06	-9.748E-03	4.957E+00
4156	27.2	6.2	3.57	9.395E-06	-9.748E-03	4.957E+00
4157	29.8	3	3.69	9.395E-06	-9.748E-03	4.957E+00
4158	29.7	3.6	3.68	9.395E-06	-9.748E-03	4.957E+00
4159	31.4	4.4	3.75	9.395E-06	-9.748E-03	4.957E+00
4160	31	5.6	3.73	9.395E-06	-9.748E-03	4.957E+00
4161	29.2	4.6	3.66	9.395E-06	-9.748E-03	4.957E+00
4162	27	5.2	3.57	9.395E-06	-9.748E-03	4.957E+00
4163	24	7.4	3.44	9.395E-06	-9.748E-03	4.957E+00
4164	22.2	8.8	3.37	9.395E-06	-9.748E-03	4.957E+00
4165	21.8	9	3.35	9.395E-06	-9.748E-03	4.957E+00
4166	23.2	8.6	3.41	9.395E-06	-9.748E-03	4.957E+00
4167	23.3	8.9	3.41	9.395E-06	-9.748E-03	4.957E+00
4168	21.2	6.4	3.33	9.395E-06	-9.748E-03	4.957E+00
4169	18.2	3.9	3.2	9.395E-06	-9.748E-03	4.957E+00
4170	13.7	7.6	3.01	9.395E-06	-9.748E-03	4.957E+00
4171	10.5	10.9	2.88	9.395E-06	-9.748E-03	4.957E+00
4172	9.9	7.9	2.85	9.395E-06	-9.748E-03	4.957E+00
4173	5.2	0.5	2.66	9.395E-06	-9.748E-03	4.957E+00
4174	0	0	2.19	9.395E-06	-9.748E-03	4.957E+00
4175	0	0	1.22	9.395E-06	-9.748E-03	4.957E+00
4176	0	0	0.53	9.395E-06	-9.748E-03	4.957E+00
4177	2.7	10	0.26	9.395E-06	-9.748E-03	4.957E+00
4178	5.1	19.6	0.04	9.395E-06	-9.748E-03	4.957E+00
4179	6.8	47.4	0.82	9.395E-06	-9.748E-03	4.957E+00
4180	6.2	45.8	1.96	9.395E-06	-9.748E-03	4.957E+00
4181	5.9	29.5	2.65	9.395E-06	-9.748E-03	4.957E+00
4182	10.2	15.6	2.86	9.395E-06	-9.748E-03	4.957E+00
4183	12.9	13.2	2.98	9.395E-06	-9.748E-03	4.957E+00
4184	13.8	17.7	3.01	9.395E-06	-9.748E-03	4.957E+00
4185	18.1	7.9	3.2	9.395E-06	-9.748E-03	4.957E+00
4186	17.3	3.6	3.16	9.395E-06	-9.748E-03	4.957E+00
4187	13.9	2.4	3.02	9.395E-06	-9.748E-03	4.957E+00
4188	12.6	0.6	2.97	9.395E-06	-9.748E-03	4.957E+00
4189	10.6	(°)	2.89	9.395E-06	-9.748E-03	4.957E+00
4190	8.1	4.3	2.77	9.395E-06	-9.748E-03	4.957E+00
4191	0	0	2.48	9.395E-06	-9.748E-03	4.957E+00
4192	0	0	1.81	9.395E-06	-9.748E-03	4.957E+00
4193	0	0	1.27	9.395E-06	-9.748E-03	4.957E+00
4194	0.8	8.7	1.01	9.395E-06	-9.748E-03	4.957E+00
4195	6.5	25	0.93	9.395E-06	-9.748E-03	4.957E+00
4196	6.3	28.5	1.41	9.395E-06	-9.748E-03	4.957E+00
4197	5.7	19.5	2	9.395E-06	-9.748E-03	4.957E+00
4198	5.4	10.8	2.3	9.395E-06	-9.748E-03	4.957E+00
4199	5.7	10.2	2.32	9.395E-06	-9.748E-03	4.957E+00
4200	6.6	16.4	2.4	9.395E-06	-9.748E-03	4.957E+00
4201	6.9	13.9	2.69	9.395E-06	-9.748E-03	4.957E+00
4202	0	0	2.58	9.395E-06	-9.748E-03	4.957E+00
4203	0	0	2.18	9.395E-06	-9.748E-03	4.957E+00
4204	0	0	1.79	9.395E-06	-9.748E-03	4.957E+00
4205	0	0	1.59	9.395E-06	-9.748E-03	4.957E+00

4206	0.2	5.8	1.44	9.395E-06	-9.748E-03	4.957E+00
4207	0.4	5.8	1.29	9.395E-06	-9.748E-03	4.957E+00
4208	0.7	10	1.24	9.395E-06	-9.748E-03	4.957E+00
4209	0.5	9.9	1.21	9.395E-06	-9.748E-03	4.957E+00
4210	0.1	5.9	1.01	9.395E-06	-9.748E-03	4.957E+00
4211	0	0	0.45	9.395E-06	-9.748E-03	4.957E+00
4212	0.6	8.4	0.07	9.395E-06	-9.748E-03	4.957E+00
4213	4.5	13.9	0	9.395E-06	-9.748E-03	4.957E+00
4214	4.9	19.7	0.06	9.395E-06	-9.748E-03	4.957E+00
4215	4.9	23.1	0.24	9.395E-06	-9.748E-03	4.957E+00
4216	4.7	22	0.44	9.395E-06	-9.748E-03	4.957E+00
4217	4.7	20.2	0.64	9.395E-06	-9.748E-03	4.957E+00
4218	4.4	15.3	0.78	9.395E-06	-9.748E-03	4.957E+00
4219	0	0	0.74	9.395E-06	-9.748E-03	4.957E+00
4220	1.3	9.9	0.72	9.395E-06	-9.748E-03	4.957E+00
4221	5.6	16.9	0.81	9.395E-06	-9.748E-03	4.957E+00
4222	5.3	14.9	1.05	9.395E-06	-9.748E-03	4.957E+00
4223	0.3	8.4	1.06	9.395E-06	-9.748E-03	4.957E+00
4224	0	0	1.04	9.395E-06	-9.748E-03	4.957E+00
4225	0.3	6.2	0.99	9.395E-06	-9.748E-03	4.957E+00
4226	0.1	5.8	0.88	9.395E-06	-9.748E-03	4.957E+00
4227	0	0	1.12	9.395E-06	-9.748E-03	4.957E+00
4228	0	0	1.03	9.395E-06	-9.748E-03	4.957E+00
4229	0	0	0.55	9.395E-06	-9.748E-03	4.957E+00
4230	0.6	8.3	0.01	9.395E-06	-9.748E-03	4.957E+00
4231	0	0	0	9.395E-06	-9.748E-03	4.957E+00
4249	0	0	0	9.395E-06	-9.748E-03	4.957E+00
4250	0	0	0	9.571E-06	-9.949E-03	4.821E+00
4251	0	0	0	9.747E-06	-1.015E-02	4.685E+00
4252	0	0	0	9.923E-06	-1.035E-02	4.549E+00
4871	0	0	0	9.923E-06	-1.035E-02	4.549E+00
4872	0.9	7.3	0	9.923E-06	-1.035E-02	4.549E+00
4873	0	0	0	9.923E-06	-1.035E-02	4.549E+00
4874	0	0	0	9.923E-06	-1.035E-02	4.549E+00
4875	1.1	6.6	0	9.923E-06	-1.035E-02	4.549E+00
4876	5.1	19.6	0	9.923E-06	-1.035E-02	4.549E+00
4877	6.3	42.9	0.4	9.923E-06	-1.035E-02	4.549E+00
4878	5.6	42.1	1.15	9.923E-06	-1.035E-02	4.549E+00
4879	5.1	28.9	1.82	9.923E-06	-1.035E-02	4.549E+00
4880	5.8	26.2	2.12	9.923E-06	-1.035E-02	4.549E+00
4881	6.1	23.6	2.56	9.923E-06	-1.035E-02	4.549E+00
4882	9.3	12.8	2.83	9.923E-06	-1.035E-02	4.549E+00
4883	12.1	12.2	2.94	9.923E-06	-1.035E-02	4.549E+00
4884	16.8	15.6	3.14	9.923E-06	-1.035E-02	4.549E+00
4885	26	16.1	3.52	9.923E-06	-1.035E-02	4.549E+00
4886	39.2	15.2	4.07	9.923E-06	-1.035E-02	4.549E+00
4887	55.7	15.4	4.76	9.923E-06	-1.035E-02	4.549E+00
4888	43.9	13.3	5.16	9.923E-06	-1.035E-02	4.549E+00
4889	36.9	23.2	5.44	9.923E-06	-1.035E-02	4.549E+00
4890	48	11.8	6.08	9.923E-06	-1.035E-02	4.549E+00
4891	55.2	13.7	6.49	9.923E-06	-1.035E-02	4.549E+00
4892	64.8	10.6	7.04	9.923E-06	-1.035E-02	4.549E+00
4893	33.1	0.7	7.06	9.923E-06	-1.035E-02	4.549E+00
4894	34.1	6.1	7.3	9.923E-06	-1.035E-02	4.549E+00
4895	32.1	(*)	7.15	9.923E-06	-1.035E-02	4.549E+00
4896	27.4	(*)	6.79	9.923E-06	-1.035E-02	4.549E+00
4897	18.5	(*)	6.08	9.923E-06	-1.035E-02	4.549E+00
4898	6.8	0.8	5.2	9.923E-06	-1.035E-02	4.549E+00
4899	0	0	4	9.923E-06	-1.035E-02	4.549E+00
4900	0	0	2.69	9.923E-06	-1.035E-02	4.549E+00
4901	0	0	1.3	9.923E-06	-1.035E-02	4.549E+00
4902	0	0	0.37	9.923E-06	-1.035E-02	4.549E+00
4903	0	0	0	9.923E-06	-1.035E-02	4.549E+00
4919	0	0	0	9.923E-06	-1.035E-02	4.549E+00
4920	0	0	0	9.399E-06	-9.777E-03	4.270E+00
4921	0	0	0	8.875E-06	-9.204E-03	3.992E+00

4922	0	0	0	8.351E-06	-8.632E-03	3.713E+00
5120	0	0	0	8.351E-06	-8.632E-03	3.713E+00
5121	1	7.5	0	8.351E-06	-8.632E-03	3.713E+00
5122	0	0	0	8.351E-06	-8.632E-03	3.713E+00
5123	0	0	0	8.351E-06	-8.632E-03	3.713E+00
5124	1.2	6.9	0	8.351E-06	-8.632E-03	3.713E+00
5125	5.9	28.2	0.07	8.351E-06	-8.632E-03	3.713E+00
5126	6	37.9	0.65	8.351E-06	-8.632E-03	3.713E+00
5127	5.7	36.4	1.29	8.351E-06	-8.632E-03	3.713E+00
5128	6.4	40.8	1.88	8.351E-06	-8.632E-03	3.713E+00
5129	7	44.4	2.48	8.351E-06	-8.632E-03	3.713E+00
5130	17.5	30.8	3.16	8.351E-06	-8.632E-03	3.713E+00
5131	33	16.5	3.81	8.351E-06	-8.632E-03	3.713E+00
5132	43.5	15.8	4.25	8.351E-06	-8.632E-03	3.713E+00
5133	54.5	11.2	4.71	8.351E-06	-8.632E-03	3.713E+00
5134	45.5	16.1	4.87	8.351E-06	-8.632E-03	3.713E+00
5135	23.1	31.7	4.65	8.351E-06	-8.632E-03	3.713E+00
5136	32.4	17.3	5.19	8.351E-06	-8.632E-03	3.713E+00
5137	40.6	6.3	5.66	8.351E-06	-8.632E-03	3.713E+00
5138	47.3	(^e)	6.05	8.351E-06	-8.632E-03	3.713E+00
5139	50.3	(^e)	6.22	8.351E-06	-8.632E-03	3.713E+00
5140	51	(^e)	6.26	8.351E-06	-8.632E-03	3.713E+00
5141	48.1	(^e)	6.1	8.351E-06	-8.632E-03	3.713E+00
5142	44.8	(^e)	5.91	8.351E-06	-8.632E-03	3.713E+00
5143	40.4	(^e)	5.66	8.351E-06	-8.632E-03	3.713E+00
5144	37.8	(^e)	5.51	8.351E-06	-8.632E-03	3.713E+00
5145	36.4	(^e)	5.42	8.351E-06	-8.632E-03	3.713E+00
5146	36.8	3.3	5.44	8.351E-06	-8.632E-03	3.713E+00
5147	41.2	2.4	5.7	8.351E-06	-8.632E-03	3.713E+00
5148	44.7	3.9	5.9	8.351E-06	-8.632E-03	3.713E+00
5149	50.1	5.6	6.21	8.351E-06	-8.632E-03	3.713E+00
5150	57.9	2.6	6.65	2.784E-06	-2.877E-03	1.238E+00
5151	57.9	12.3	6.84	-2.784E-06	2.877E-03	-1.238E+00
5152	24.4	(^e)	6.54	-8.351E-06	8.632E-03	-3.713E+00
5153	16.9	1	5.94	-8.351E-06	8.632E-03	-3.713E+00
5154	10.7	0.7	5.45	-8.351E-06	8.632E-03	-3.713E+00
5155	28.2	16.1	4.74	-8.351E-06	8.632E-03	-3.713E+00
5156	5.3	1	3.66	-8.351E-06	8.632E-03	-3.713E+00
5157	0.1	6	2.44	-8.351E-06	8.632E-03	-3.713E+00
5158	0	0	1.55	-8.351E-06	8.632E-03	-3.713E+00
5159	0	0	1.16	-8.351E-06	8.632E-03	-3.713E+00
5160	0.4	5.8	0.82	-8.351E-06	8.632E-03	-3.713E+00
5161	1.4	9.5	0.52	-2.558E-06	2.662E-03	-1.372E+00
5162	6.2	28.4	0.59	3.235E-06	-3.307E-03	9.693E-01
5163	6.8	41	1.18	9.029E-06	-9.277E-03	3.311E+00
5164	5.7	34.4	2.06	9.029E-06	-9.277E-03	3.311E+00
5165	5.4	23.3	2.3	9.029E-06	-9.277E-03	3.311E+00
5166	5.9	22.2	2.34	9.029E-06	-9.277E-03	3.311E+00
5167	6.1	21.1	2.39	9.029E-06	-9.277E-03	3.311E+00
5168	6.2	19.5	2.45	9.029E-06	-9.277E-03	3.311E+00
5169	6.4	20.2	2.42	9.029E-06	-9.277E-03	3.311E+00
5170	6.9	29.3	2.28	9.029E-06	-9.277E-03	3.311E+00
5171	6	18.2	2.49	9.029E-06	-9.277E-03	3.311E+00
5172	6.7	26.6	2.37	9.029E-06	-9.277E-03	3.311E+00
5173	5.8	13.1	2.67	9.029E-06	-9.277E-03	3.311E+00
5174	7	10.2	2.73	9.029E-06	-9.277E-03	3.311E+00
5175	7.4	9.2	2.75	9.029E-06	-9.277E-03	3.311E+00
5176	7.5	9	2.75	9.029E-06	-9.277E-03	3.311E+00
5177	7.5	8.8	2.75	9.029E-06	-9.277E-03	3.311E+00
5178	7.5	8.8	2.75	9.029E-06	-9.277E-03	3.311E+00
5179	8.7	16.8	2.8	9.029E-06	-9.277E-03	3.311E+00
5180	20.1	20.7	3.27	9.029E-06	-9.277E-03	3.311E+00
5181	33.4	16	3.83	9.029E-06	-9.277E-03	3.311E+00
5182	49.7	13.4	4.51	9.029E-06	-9.277E-03	3.311E+00
5183	57.2	6.8	4.83	9.029E-06	-9.277E-03	3.311E+00
5184	26.8	1	4.73	9.029E-06	-9.277E-03	3.311E+00

5185	21.1	24.2	4.54	9.029E-06	-9.277E-03	3.311E+00
5186	25.4	14	4.79	9.029E-06	-9.277E-03	3.311E+00
5187	26.1	11.9	4.83	9.029E-06	-9.277E-03	3.311E+00
5188	28	7.4	4.94	9.029E-06	-9.277E-03	3.311E+00
5189	28.5	6	4.97	9.029E-06	-9.277E-03	3.311E+00
5190	28.5	5.7	4.97	9.029E-06	-9.277E-03	3.311E+00
5191	28.4	5.6	4.96	9.029E-06	-9.277E-03	3.311E+00
5192	28.2	5.6	4.95	9.029E-06	-9.277E-03	3.311E+00
5193	28.1	5.6	4.94	9.029E-06	-9.277E-03	3.311E+00
5194	27.9	5.7	4.94	9.029E-06	-9.277E-03	3.311E+00
5195	29.5	14.7	5.02	9.029E-06	-9.277E-03	3.311E+00
5196	40.8	21.2	5.66	9.029E-06	-9.277E-03	3.311E+00
5197	56.3	21.8	6.54	9.029E-06	-9.277E-03	3.311E+00
5198	68.3	13.8	7.24	9.029E-06	-9.277E-03	3.311E+00
5199	33.3	2.8	7.05	9.029E-06	-9.277E-03	3.311E+00
5200	42.1	40.5	7.9	9.029E-06	-9.277E-03	3.311E+00
5201	59.3	19.7	9.27	9.029E-06	-9.277E-03	3.311E+00
5202	67.3	9.5	9.92	9.029E-06	-9.277E-03	3.311E+00
5203	38.3	0.5	10.23	9.029E-06	-9.277E-03	3.311E+00
5204	42.7	37	10.89	9.029E-06	-9.277E-03	3.311E+00
5205	49.4	19.3	11.64	9.029E-06	-9.277E-03	3.311E+00
5206	56.8	10.7	12.44	9.029E-06	-9.277E-03	3.311E+00
5207	63.5	24.7	13.15	9.029E-06	-9.277E-03	3.311E+00
5208	42.4	13.5	13.24	9.029E-06	-9.277E-03	3.311E+00
5209	25.9	51.3	12.47	9.029E-06	-9.277E-03	3.311E+00
5210	30.8	72.4	13.18	9.029E-06	-9.277E-03	3.311E+00
5211	38.7	13.4	14.38	3.010E-06	-3.092E-03	1.104E+00
5212	38	(°)	14.3	-3.010E-06	3.092E-03	-1.104E+00
5213	31.1	(°)	13.3	-9.029E-06	9.277E-03	-3.311E+00
5214	18.8	(°)	11.48	-9.029E-06	9.277E-03	-3.311E+00
5215	9.7	17.8	9.06	-9.029E-06	9.277E-03	-3.311E+00
5216	2.1	0.2	6.13	-9.029E-06	9.277E-03	-3.311E+00
5217	0.1	5.8	3.32	-9.029E-06	9.277E-03	-3.311E+00
5218	0	0	1.29	-9.029E-06	9.277E-03	-3.311E+00
5219	0	0	0.34	-9.029E-06	9.277E-03	-3.311E+00
5220	0	0	0	-9.029E-06	9.277E-03	-3.311E+00
5249	0	0	0	-9.029E-06	9.277E-03	-3.311E+00
5250	0	0	0	-7.324E-07	8.211E-04	-3.593E-01
5251	0	0	0	7.564E-06	-7.634E-03	2.592E+00
5252	0	0	0	1.586E-05	-1.609E-02	5.543E+00
5282	0	0	0	1.586E-05	-1.609E-02	5.543E+00
5283	0.8	9.8	0	1.586E-05	-1.609E-02	5.543E+00
5284	6.6	37.6	0.49	1.586E-05	-1.609E-02	5.543E+00
5285	6.5	41.8	1.56	1.586E-05	-1.609E-02	5.543E+00
5286	5.7	27.5	2.36	1.586E-05	-1.609E-02	5.543E+00
5287	5.4	14.6	2.62	1.586E-05	-1.609E-02	5.543E+00
5288	4.3	4.8	2.35	1.586E-05	-1.609E-02	5.543E+00
5289	0	0	1.8	1.586E-05	-1.609E-02	5.543E+00
5290	0	0	0.99	1.586E-05	-1.609E-02	5.543E+00
5291	0	0	0.2	1.586E-05	-1.609E-02	5.543E+00
5292	1.8	9.6	0	1.586E-05	-1.609E-02	5.543E+00
5293	7.7	54.2	0.41	1.586E-05	-1.609E-02	5.543E+00
5294	7.2	74	2.08	1.586E-05	-1.609E-02	5.543E+00
5295	26.2	44	3.52	1.586E-05	-1.609E-02	5.543E+00
5296	56.6	26.2	4.78	1.586E-05	-1.609E-02	5.543E+00
5297	41.1	15.5	4.94	1.586E-05	-1.609E-02	5.543E+00
5298	15.7	3.7	4.03	1.586E-05	-1.609E-02	5.543E+00
5299	25.6	54.8	4.78	1.586E-05	-1.609E-02	5.543E+00
5300	58.4	41.3	6.64	1.586E-05	-1.609E-02	5.543E+00
5301	79.3	27.1	7.86	1.586E-05	-1.609E-02	5.543E+00
5302	45	0.8	7.98	1.586E-05	-1.609E-02	5.543E+00
5303	52.4	49	8.7	1.586E-05	-1.609E-02	5.543E+00
5304	84.7	84.8	11.22	1.586E-05	-1.609E-02	5.543E+00
5305	85.6	30.4	12.14	1.586E-05	-1.609E-02	5.543E+00
5306	47.3	2.8	11.42	1.586E-05	-1.609E-02	5.543E+00
5307	52.6	65.9	11.95	1.586E-05	-1.609E-02	5.543E+00

5308	67.5	87.5	13.53	1.586E-05	-1.609E-02	5.543E+00
5309	85.6	57.5	15.51	1.586E-05	-1.609E-02	5.543E+00
5310	92.5	52	16.26	1.586E-05	-1.609E-02	5.543E+00
5311	67.3	17.9	16.49	1.586E-05	-1.609E-02	5.543E+00
5312	50.8	39.2	16.16	1.586E-05	-1.609E-02	5.543E+00
5313	54.7	74.5	16.7	1.586E-05	-1.609E-02	5.543E+00
5314	61.2	90.7	17.65	1.586E-05	-1.609E-02	5.543E+00
5315	70.6	97	19.03	1.586E-05	-1.609E-02	5.543E+00
5316	82.2	95.2	20.76	1.586E-05	-1.609E-02	5.543E+00
5317	90.7	33.2	22.06	1.586E-05	-1.609E-02	5.543E+00
5318	53	2.5	22.66	1.586E-05	-1.609E-02	5.543E+00
5319	58.2	62	23.82	1.586E-05	-1.609E-02	5.543E+00
5320	64.7	43.3	25.15	1.586E-05	-1.609E-02	5.543E+00
5321	68.1	53.2	25.84	1.586E-05	-1.609E-02	5.543E+00
5322	70.3	80.1	26.27	1.586E-05	-1.609E-02	5.543E+00
5323	73.6	35	26.99	1.586E-05	-1.609E-02	5.543E+00
5324	74.1	26.3	27.09	1.586E-05	-1.609E-02	5.543E+00
5325	43.6	7.6	26.9	5.287E-06	-5.363E-03	1.848E+00
5326	37.1	12.3	26.76	-5.287E-06	5.363E-03	-1.848E+00
5327	35.9	8.2	26.41	-1.586E-05	1.609E-02	-5.543E+00
5328	34.1	(^e)	25.95	-1.586E-05	1.609E-02	-5.543E+00
5329	30.2	(^e)	24.87	-1.586E-05	1.609E-02	-5.543E+00
5330	23.3	(^e)	23	-1.586E-05	1.609E-02	-5.543E+00
5331	14.2	(^e)	20.44	-1.586E-05	1.609E-02	-5.543E+00
5332	30.7	1.7	17.84	-1.586E-05	1.609E-02	-5.543E+00
5333	19.7	(^e)	16	-1.586E-05	1.609E-02	-5.543E+00
5334	15.1	12.6	15.03	-1.586E-05	1.609E-02	-5.543E+00
5335	43.1	5.7	14.64	-1.586E-05	1.609E-02	-5.543E+00
5336	39.2	(^e)	14.48	-1.586E-05	1.609E-02	-5.543E+00
5337	35.7	(^e)	13.98	-1.586E-05	1.609E-02	-5.543E+00
5338	30.1	(^e)	13.14	-1.586E-05	1.609E-02	-5.543E+00
5339	24.4	(^e)	12.28	-1.586E-05	1.609E-02	-5.543E+00
5340	21.6	(^e)	11.86	-1.586E-05	1.609E-02	-5.543E+00
5341	21.3	(^e)	11.81	-1.586E-05	1.609E-02	-5.543E+00
5342	20.1	4.4	11.62	-1.586E-05	1.609E-02	-5.543E+00
5343	20.1	10	11.63	-1.586E-05	1.609E-02	-5.543E+00
5344	20.4	6.1	11.67	-1.586E-05	1.609E-02	-5.543E+00
5345	19.1	(^e)	11.48	-1.586E-05	1.609E-02	-5.543E+00
5346	16	(^e)	11.03	-1.586E-05	1.609E-02	-5.543E+00
5347	12.8	(^e)	10.54	-1.586E-05	1.609E-02	-5.543E+00
5348	9.4	(^e)	10.04	-1.586E-05	1.609E-02	-5.543E+00
5349	8.4	(^e)	9.9	-1.586E-05	1.609E-02	-5.543E+00
5350	8.2	(^e)	9.88	-1.586E-05	1.609E-02	-5.543E+00
5351	32.6	20.1	9.63	-1.586E-05	1.609E-02	-5.543E+00
5352	27.9	(^e)	9.32	-5.287E-06	5.363E-03	-1.848E+00
5353	26.6	20.9	9.18	5.287E-06	-5.363E-03	1.848E+00
5354	30.9	32	9.62	1.326E-05	-1.356E-02	4.569E+00
5355	33.2	21.5	9.89	1.065E-05	-1.104E-02	3.596E+00
5356	32.4	2.7	9.8	8.046E-06	-8.510E-03	2.622E+00
5357	34.7	19.6	10.04	8.046E-06	-8.510E-03	2.622E+00
5358	46.7	35.6	11.32	8.046E-06	-8.510E-03	2.622E+00
5359	61.8	44.7	12.94	8.046E-06	-8.510E-03	2.622E+00
5360	74.1	43.8	14.28	8.046E-06	-8.510E-03	2.622E+00
5361	79.1	27.1	14.83	8.046E-06	-8.510E-03	2.622E+00
5362	40	3	14.23	8.046E-06	-8.510E-03	2.622E+00
5363	38.7	58.8	14.35	8.046E-06	-8.510E-03	2.622E+00
5364	47	81.8	15.55	8.046E-06	-8.510E-03	2.622E+00
5365	59.3	92.7	17.36	8.046E-06	-8.510E-03	2.622E+00
5366	72.4	96.5	19.31	8.046E-06	-8.510E-03	2.622E+00
5367	80.9	50.4	20.61	8.046E-06	-8.510E-03	2.622E+00
5368	85.8	58	21.33	8.046E-06	-8.510E-03	2.622E+00
5369	47.8	0.5	21.32	8.046E-06	-8.510E-03	2.622E+00
5370	47.6	52.3	21.65	8.046E-06	-8.510E-03	2.622E+00
5371	52.8	81.7	22.7	8.046E-06	-8.510E-03	2.622E+00
5372	59.2	93.4	23.98	8.046E-06	-8.510E-03	2.622E+00
5373	65.5	98.3	25.28	8.046E-06	-8.510E-03	2.622E+00

5374	72.3	98.2	26.67	8.046E-06	-8.510E-03	2.622E+00
5375	75.3	21.6	27.33	8.046E-06	-8.510E-03	2.622E+00
5376	76.1	42.7	27.48	8.046E-06	-8.510E-03	2.622E+00
5377	40	1.5	27.03	8.046E-06	-8.510E-03	2.622E+00
5378	38.4	58.3	27.09	8.046E-06	-8.510E-03	2.622E+00
5379	40.8	83.1	27.75	8.046E-06	-8.510E-03	2.622E+00
5380	43.6	92.9	28.53	8.046E-06	-8.510E-03	2.622E+00
5381	46.7	96.7	29.38	8.046E-06	-8.510E-03	2.622E+00
5382	50.1	98.4	30.32	8.046E-06	-8.510E-03	2.622E+00
5383	53	99.3	31.15	8.046E-06	-8.510E-03	2.622E+00
5384	56.2	99	32.05	8.046E-06	-8.510E-03	2.622E+00
5385	59.9	58.3	33.11	8.046E-06	-8.510E-03	2.622E+00
5386	61.8	38.7	33.66	8.046E-06	-8.510E-03	2.622E+00
5387	62.9	41	33.95	8.046E-06	-8.510E-03	2.622E+00
5388	30.9	1.4	33.81	8.046E-06	-8.510E-03	2.622E+00
5389	29.2	64.2	33.85	8.046E-06	-8.510E-03	2.622E+00
5390	29.7	86	34.03	8.046E-06	-8.510E-03	2.622E+00
5391	30.5	93.5	34.31	8.046E-06	-8.510E-03	2.622E+00
5392	31.4	60	34.69	8.046E-06	-8.510E-03	2.622E+00
5393	31.8	34.9	34.86	8.046E-06	-8.510E-03	2.622E+00
5394	31.6	45.6	34.78	8.046E-06	-8.510E-03	2.622E+00
5395	31.8	45.8	34.83	2.682E-06	-2.837E-03	8.740E-01
5396	31.8	(°)	34.87	-2.682E-06	2.837E-03	-8.740E-01
5397	30.6	(°)	34.44	-8.046E-06	8.510E-03	-2.622E+00
5398	29.4	4.1	33.94	-8.046E-06	8.510E-03	-2.622E+00
5399	28.4	(°)	33.58	-8.046E-06	8.510E-03	-2.622E+00
5400	27.6	(°)	33.26	-8.046E-06	8.510E-03	-2.622E+00
5401	26.6	4.6	32.87	-8.046E-06	8.510E-03	-2.622E+00
5402	26	(°)	32.62	-8.046E-06	8.510E-03	-2.622E+00
5403	25	14.2	32.25	-8.046E-06	8.510E-03	-2.622E+00
5404	24.4	8.2	32.02	-8.046E-06	8.510E-03	-2.622E+00
5405	24.1	(°)	31.92	-8.046E-06	8.510E-03	-2.622E+00
5406	23.2	(°)	31.57	-8.046E-06	8.510E-03	-2.622E+00
5407	22.5	(°)	31.29	-8.046E-06	8.510E-03	-2.622E+00
5408	21.8	(°)	31	-8.046E-06	8.510E-03	-2.622E+00
5409	20.6	9.5	30.56	-8.046E-06	8.510E-03	-2.622E+00
5410	19.6	4.5	30.15	-8.046E-06	8.510E-03	-2.622E+00
5411	18.7	(°)	29.81	-8.046E-06	8.510E-03	-2.622E+00
5412	18	(°)	29.56	-8.046E-06	8.510E-03	-2.622E+00
5413	16.5	(°)	28.96	-8.046E-06	8.510E-03	-2.622E+00
5414	17.2	13.8	28.18	-8.046E-06	8.510E-03	-2.622E+00
5415	40.8	2.2	27.26	-8.046E-06	8.510E-03	-2.622E+00
5416	36.4	(°)	26.59	-8.046E-06	8.510E-03	-2.622E+00
5417	34.8	(°)	26.13	-8.046E-06	8.510E-03	-2.622E+00
5418	33.5	(°)	25.76	-8.046E-06	8.510E-03	-2.622E+00
5419	31.7	(°)	25.28	-8.046E-06	8.510E-03	-2.622E+00
5420	27.1	(°)	24	-8.046E-06	8.510E-03	-2.622E+00
5421	20	(°)	22.03	-8.046E-06	8.510E-03	-2.622E+00
5422	26.2	22.1	19.59	-8.046E-06	8.510E-03	-2.622E+00
5423	25.5	7.2	16.5	-8.046E-06	8.510E-03	-2.622E+00
5424	33.7	15.3	13.16	-8.046E-06	8.510E-03	-2.622E+00
5425	15.9	(°)	11.03	-8.046E-06	8.510E-03	-2.622E+00
5426	10.8	(°)	10.25	-8.046E-06	8.510E-03	-2.622E+00
5427	9.4	6.8	10.04	-2.682E-06	2.837E-03	-8.740E-01
5428	11	45	10.27	2.682E-06	-2.837E-03	8.740E-01
5429	15.6	61.7	10.94	8.046E-06	-8.510E-03	2.622E+00
5430	20.1	44.6	11.62	8.046E-06	-8.510E-03	2.622E+00
5431	23.1	47	12.06	8.046E-06	-8.510E-03	2.622E+00
5432	27	43	12.63	8.046E-06	-8.510E-03	2.622E+00
5433	31.6	43.2	13.3	8.046E-06	-8.510E-03	2.622E+00
5434	36.1	33	13.98	8.046E-06	-8.510E-03	2.622E+00
5435	38.7	21	14.38	8.046E-06	-8.510E-03	2.622E+00
5436	41.9	36.1	14.84	8.046E-06	-8.510E-03	2.622E+00
5437	47.2	48.6	15.6	8.046E-06	-8.510E-03	2.622E+00
5438	55.4	69.9	16.8	8.046E-06	-8.510E-03	2.622E+00
5439	65.4	71.9	18.28	8.046E-06	-8.510E-03	2.622E+00

5440	72.7	55	19.38	8.046E-06	-8.510E-03	2.622E+00
5441	76.7	33.4	19.99	8.046E-06	-8.510E-03	2.622E+00
5442	41.3	1.5	19.89	8.046E-06	-8.510E-03	2.622E+00
5443	39.1	49.6	19.92	8.046E-06	-8.510E-03	2.622E+00
5444	44	79.4	20.89	8.046E-06	-8.510E-03	2.622E+00
5445	50.2	58	22.17	8.046E-06	-8.510E-03	2.622E+00
5446	53.4	43.9	22.85	8.046E-06	-8.510E-03	2.622E+00
5447	56.3	52.2	23.42	8.046E-06	-8.510E-03	2.622E+00
5448	60.4	67.4	24.25	8.046E-06	-8.510E-03	2.622E+00
5449	64.7	61.3	25.14	8.046E-06	-8.510E-03	2.622E+00
5450	68	51.4	25.82	8.046E-06	-8.510E-03	2.622E+00
5451	70.9	50.6	26.43	8.046E-06	-8.510E-03	2.622E+00
5452	41	6.3	26.52	8.046E-06	-8.510E-03	2.622E+00
5453	36.5	46.3	26.57	8.046E-06	-8.510E-03	2.622E+00
5454	38	57.7	26.99	8.046E-06	-8.510E-03	2.622E+00
5455	39.9	59.5	27.49	8.046E-06	-8.510E-03	2.622E+00
5456	41.9	65.2	28.07	8.046E-06	-8.510E-03	2.622E+00
5457	44.4	77.2	28.74	8.046E-06	-8.510E-03	2.622E+00
5458	46.9	69.5	29.45	8.046E-06	-8.510E-03	2.622E+00
5459	48.7	48.9	29.97	8.046E-06	-8.510E-03	2.622E+00
5460	49.9	38.1	30.32	8.046E-06	-8.510E-03	2.622E+00
5461	50.3	19.6	30.43	8.046E-06	-8.510E-03	2.622E+00
5462	49.5	(^e)	30.26	8.046E-06	-8.510E-03	2.622E+00
5463	48.2	(^e)	29.88	2.682E-06	-2.837E-03	8.740E-01
5464	46.6	(^e)	29.44	-2.682E-06	2.837E-03	-8.740E-01
5465	45.3	(^e)	29.06	-8.046E-06	8.510E-03	-2.622E+00
5466	43.5	(^e)	28.59	-8.046E-06	8.510E-03	-2.622E+00
5467	40.3	(^e)	27.7	-8.046E-06	8.510E-03	-2.622E+00
5468	35.8	(^e)	26.44	-8.046E-06	8.510E-03	-2.622E+00
5469	32.1	(^e)	25.39	-8.046E-06	8.510E-03	-2.622E+00
5470	28.4	(^e)	24.37	-8.046E-06	8.510E-03	-2.622E+00
5471	22.8	(^e)	22.82	-8.046E-06	8.510E-03	-2.622E+00
5472	14.5	6.3	20.09	-8.046E-06	8.510E-03	-2.622E+00
5473	22.7	(^e)	16.17	-8.046E-06	8.510E-03	-2.622E+00
5474	27.5	8.8	12.18	-8.046E-06	8.510E-03	-2.622E+00
5475	6.4	3.7	9.5	-8.046E-06	8.510E-03	-2.622E+00
5476	20.7	(^e)	8.26	-8.046E-06	8.510E-03	-2.622E+00
5477	13.7	(^e)	7.79	-8.046E-06	8.510E-03	-2.622E+00
5478	9.9	(^e)	7.38	-8.046E-06	8.510E-03	-2.622E+00
5479	0	0	6.77	-8.046E-06	8.510E-03	-2.622E+00
5480	0	0	6.1	-8.046E-06	8.510E-03	-2.622E+00
5481	0	0	5.44	-8.046E-06	8.510E-03	-2.622E+00
5482	0	0	5.21	-8.046E-06	8.510E-03	-2.622E+00
5483	0.7	5.9	5.25	-8.046E-06	8.510E-03	-2.622E+00
5484	36.3	46.1	5.77	-8.046E-06	8.510E-03	-2.622E+00
5485	34.1	(^e)	5.3	-8.046E-06	8.510E-03	-2.622E+00
5486	26.5	(^e)	4.86	-8.046E-06	8.510E-03	-2.622E+00
5487	20.6	2.3	4.52	-8.046E-06	8.510E-03	-2.622E+00
5488	16	(^e)	4.26	-8.046E-06	8.510E-03	-2.622E+00
5489	10.2	(^e)	3.93	-8.046E-06	8.510E-03	-2.622E+00
5490	0	0	3.43	-8.046E-06	8.510E-03	-2.622E+00
5491	0	0	2.99	-8.046E-06	8.510E-03	-2.622E+00
5492	0	0	3.03	-8.046E-06	8.510E-03	-2.622E+00
5493	0	0	2.99	-8.046E-06	8.510E-03	-2.622E+00
5494	0	0	2.61	-8.046E-06	8.510E-03	-2.622E+00
5495	0	0	2.22	-8.046E-06	8.510E-03	-2.622E+00
5496	0	0	1.85	-8.046E-06	8.510E-03	-2.622E+00
5497	0	0	1.69	-8.046E-06	8.510E-03	-2.622E+00
5498	0	0	1.59	-8.046E-06	8.510E-03	-2.622E+00
5499	0	0	1.57	-8.046E-06	8.510E-03	-2.622E+00
5500	0	0	1.59	-8.046E-06	8.510E-03	-2.622E+00
5501	0	0	1.45	-8.046E-06	8.510E-03	-2.622E+00
5502	0	0	1.09	-8.046E-06	8.510E-03	-2.622E+00
5503	0	0	0.62	-8.046E-06	8.510E-03	-2.622E+00
5504	0	0	0.27	-8.046E-06	8.510E-03	-2.622E+00
5505	0	0	0	-8.046E-06	8.510E-03	-2.622E+00

| ^aClosed throttle motoring.

Appendix C ~~to of~~ Part 1036 — Default Engine Fuel Maps for § 1036.540

GEM contains the ~~This appendix includes~~ default steady-state fuel maps in this appendix for performing cycle-average engine fuel mapping as described in ~~§§ 1036.535 and~~ 1036.540 ~~503(b)(2)~~. Note that manufacturers have the option to replace these default values in GEM if they generate a steady-state fuel map as described in § 1036.535(b).

(a) Use the following default fuel map for compression-ignition engines that will be installed in Tractors and Vocational Heavy HDV:

Table 1 of Appendix C—Default Fuel Map for Compression-Ignition Engines Installed in Tractors and Vocational Heavy HDV

Engine Speed (r/min)	Engine Torque (N-m)	Fuel Mass Rate (g/sec)						
666.7	0	0.436	1833.3	900	9.821	1333.3	2100	14.969
833.3	0	0.665	2000.0	900	11.08	1500.0	2100	16.971
1000.0	0	0.94	2166.7	900	13.051	1666.7	2100	19.274
1166.7	0	1.002	2333.3	900	15.002	1833.3	2100	22.09
1333.3	0	1.17	2500.0	900	16.862	2000.0	2100	25.654
1500.0	0	1.5	500.0	1200	3.833	2166.7	2100	29.399
1666.7	0	1.899	666.7	1200	4.679	2333.3	2100	32.958
1833.3	0	2.378	833.3	1200	5.535	2500.0	2100	36.543
2000.0	0	2.93	1000.0	1200	6.519	500.0	2400	17.446
2166.7	0	3.516	1166.7	1200	7.603	666.7	2400	16.922
2333.3	0	4.093	1333.3	1200	8.735	833.3	2400	15.981
2500.0	0	4.672	1500.0	1200	9.948	1000.0	2400	14.622
500.0	300	0.974	1666.7	1200	11.226	1166.7	2400	15.079
666.7	300	1.405	1833.3	1200	12.622	1333.3	2400	17.165
833.3	300	1.873	2000.0	1200	14.228	1500.0	2400	19.583
1000.0	300	2.324	2166.7	1200	16.488	1666.7	2400	22.408
1166.7	300	2.598	2333.3	1200	18.921	1833.3	2400	25.635
1333.3	300	2.904	2500.0	1200	21.263	2000.0	2400	29.22
1500.0	300	3.397	500.0	1500	6.299	2166.7	2400	33.168
1666.7	300	3.994	666.7	1500	6.768	2333.3	2400	37.233
1833.3	300	4.643	833.3	1500	6.95	2500.0	2400	41.075
2000.0	300	5.372	1000.0	1500	8.096	500.0	2700	22.365
2166.7	300	6.141	1166.7	1500	9.399	666.7	2700	21.511
2333.3	300	7.553	1333.3	1500	10.764	833.3	2700	20.225
2500.0	300	8.449	1500.0	1500	12.238	1000.0	2700	17.549
500.0	600	1.723	1666.7	1500	13.827	1166.7	2700	17.131
666.7	600	2.391	1833.3	1500	15.586	1333.3	2700	19.588
833.3	600	3.121	2000.0	1500	17.589	1500.0	2700	22.514
1000.0	600	3.756	2166.7	1500	20.493	1666.7	2700	25.574
1166.7	600	4.197	2333.3	1500	23.366	1833.3	2700	28.909
1333.3	600	4.776	2500.0	1500	26.055	2000.0	2700	32.407
1500.0	600	5.492	500.0	1800	9.413	2166.7	2700	36.18
1666.7	600	6.277	666.7	1800	9.551	2333.3	2700	40.454
1833.3	600	7.129	833.3	1800	8.926	2500.0	2700	44.968
2000.0	600	8.069	1000.0	1800	9.745	500.0	3000	27.476
2166.7	600	9.745	1166.7	1800	11.26	666.7	3000	22.613
2333.3	600	11.213	1333.3	1800	12.819	833.3	3000	19.804
2500.0	600	12.59	1500.0	1800	14.547	1000.0	3000	17.266
500.0	900	2.637	1666.7	1800	16.485	1166.7	3000	19.197
666.7	900	3.444	1833.3	1800	18.697	1333.3	3000	22.109
833.3	900	4.243	2000.0	1800	21.535	1500.0	3000	25.288
1000.0	900	4.997	2166.7	1800	24.981	1666.7	3000	28.44
1166.7	900	5.802	2333.3	1800	28.404	1833.3	3000	31.801
1333.3	900	6.702	2500.0	1800	31.768	2000.0	3000	35.405
1500.0	900	7.676	500.0	2100	13.128	2166.7	3000	39.152
1666.7	900	8.7	666.7	2100	12.936	2333.3	3000	42.912
			833.3	2100	12.325	2500.0	3000	47.512
			1000.0	2100	11.421			
			1166.7	2100	13.174			

(b) Use the following default fuel map for compression-ignition engines that will be installed in Vocational Light HDV and Vocational Medium HDV:

Table 2 of Appendix C—Default Fuel Map for Compression-Ignition Engines Installed in Vocational Light HDV and Vocational Medium HDV

Engine Speed (r/min)	Engine Torque (N·m)	Fuel Mass Rate (g/sec)						
708.3	0	0.255	2166.7	360	5.451	1541.7	840	7.883
916.7	0	0.263	2375.0	360	6.16	1750.0	840	8.94
1125.0	0	0.342	2583.3	360	7.009	1958.3	840	10.093
1333.3	0	0.713	2791.7	360	8.007	2166.7	840	11.329
1541.7	0	0.885	3000.0	360	8.995	2375.0	840	12.613
1750.0	0	1.068	500.0	480	1.676	2583.3	840	13.983
1958.3	0	1.27	708.3	480	2.194	2791.7	840	15.419
2166.7	0	1.593	916.7	480	2.76	3000.0	840	16.853
2375.0	0	1.822	1125.0	480	3.408	500.0	960	4.251
2583.3	0	2.695	1333.3	480	4.031	708.3	960	5.098
2791.7	0	4.016	1541.7	480	4.649	916.7	960	5.974
3000.0	0	5.324	1750.0	480	5.309	1125.0	960	6.917
500.0	120	0.515	1958.3	480	6.052	1333.3	960	7.889
708.3	120	0.722	2166.7	480	6.849	1541.7	960	8.913
916.7	120	0.837	2375.0	480	7.681	1750.0	960	10.152
1125.0	120	1.097	2583.3	480	8.783	1958.3	960	11.482
1333.3	120	1.438	2791.7	480	10.073	2166.7	960	12.87
1541.7	120	1.676	3000.0	480	11.36	2375.0	960	14.195
1750.0	120	1.993	500.0	600	2.147	2583.3	960	15.562
1958.3	120	2.35	708.3	600	2.787	2791.7	960	16.995
2166.7	120	2.769	916.7	600	3.478	3000.0	960	18.492
2375.0	120	3.306	1125.0	600	4.227	500.0	1080	4.978
2583.3	120	4.004	1333.3	600	4.999	708.3	1080	5.928
2791.7	120	4.78	1541.7	600	5.737	916.7	1080	6.877
3000.0	120	5.567	1750.0	600	6.511	1125.0	1080	7.827
500.0	240	0.862	1958.3	600	7.357	1333.3	1080	8.838
708.3	240	1.158	2166.7	600	8.289	1541.7	1080	9.91
916.7	240	1.462	2375.0	600	9.295	1750.0	1080	11.347
1125.0	240	1.85	2583.3	600	10.541	1958.3	1080	12.85
1333.3	240	2.246	2791.7	600	11.914	2166.7	1080	14.398
1541.7	240	2.603	3000.0	600	13.286	2375.0	1080	15.745
1750.0	240	3.086	500.0	720	2.744	2583.3	1080	17.051
1958.3	240	3.516	708.3	720	3.535	2791.7	1080	18.477
2166.7	240	4.093	916.7	720	4.356	3000.0	1080	19.971
2375.0	240	4.726	1125.0	720	5.102	500.0	1200	5.888
2583.3	240	5.372	1333.3	720	5.968	708.3	1200	6.837
2791.7	240	6.064	1541.7	720	6.826	916.7	1200	7.787
3000.0	240	6.745	1750.0	720	7.733	1125.0	1200	8.736
500.0	360	1.221	1958.3	720	8.703	1333.3	1200	9.786
708.3	360	1.651	2166.7	720	9.792	1541.7	1200	10.908
916.7	360	2.099	2375.0	720	10.984	1750.0	1200	12.541
1125.0	360	2.62	2583.3	720	12.311	1958.3	1200	14.217
1333.3	360	3.116	2791.7	720	13.697	2166.7	1200	15.925
1541.7	360	3.604	3000.0	720	15.071	2375.0	1200	17.3
1750.0	360	4.172	500.0	840	3.518	2583.3	1200	18.606
1958.3	360	4.754	708.3	840	4.338	2791.7	1200	19.912
			916.7	840	5.186	3000.0	1200	21.357
			1125.0	840	6.063			
			1333.3	840	6.929			

(c) Use the following default fuel map for all spark-ignition engines:

Table 3 of Appendix C—Default Fuel Map for Spark-Ignition Engines

Engine Speed (r/min)	Engine Torque (N·m)	Fuel Mass Rate (g/sec)							
875	0	0.535							
1250	0	0.734							
1625	0	0.975							
2000	0	1.238							
2375	0	1.506							
2750	0	1.772							
3125	0	2.07							
3500	0	2.394							
3875	0	2.795							
4250	0	3.312							
4625	0	3.349							
5000	0	3.761							
500	65	0.458							
875	65	0.759							
1250	65	1.065							
1625	65	1.43							
2000	65	1.812							
2375	65	2.22							
2750	65	2.65							
3125	65	3.114							
3500	65	3.646							
3875	65	4.225							
4250	65	4.861							
4625	65	5.328							
5000	65	6.028							
500	130	0.666							
875	130	1.063							
1250	130	1.497							
1625	130	1.976							
2000	130	2.469							
2375	130	3.015							
2750	130	3.59							
3125	130	4.218							
3500	130	4.9							
3875	130	5.652							
4250	130	6.484							
4625	130	7.308							
5000	130	8.294							
500	195	0.856							
875	195	1.377							
1250	195	1.923							
1625	195	2.496							
2000	195	3.111							
2375	195	3.759							
2750	195	4.49							
3125	195	5.269							
			3500	195	6.13				
			3875	195	7.124				
			4250	195	8.189				
			4625	195	9.288				
			5000	195	10.561				
			500	260	1.079				
			875	260	1.716				
			1250	260	2.373				
			1625	260	3.083				
			2000	260	3.832				
			2375	260	4.599				
			2750	260	5.443				
			3125	260	6.391				
			3500	260	7.444				
			3875	260	8.564				
			4250	260	9.821				
			4625	260	11.268				
			5000	260	12.828				
			500	325	1.354				
			875	325	2.06				
			1250	325	2.844				
			1625	325	3.696				
			2000	325	4.579				
			2375	325	5.466				
			2750	325	6.434				
			3125	325	7.542				
			3500	325	8.685				
			3875	325	9.768				
			4250	325	11.011				
			4625	325	13.249				
			5000	325	15.095				
			500	390	1.609				
			875	390	2.44				
			1250	390	3.317				
			1625	390	4.31				
			2000	390	5.342				
			2375	390	6.362				
			2750	390	7.489				
			3125	390	8.716				
			3500	390	9.865				
			3875	390	10.957				
			4250	390	12.405				
			4625	390	15.229				
			5000	390	17.363				
			500	455	2.245				
			875	455	2.969				
			1250	455	3.867				
			1625	455	4.992				
			2000	455	6.215				
						2375	455	7.415	
						2750	455	8.76	
						3125	455	10.175	
						3500	455	11.53	
						3875	455	12.889	
						4250	455	14.686	
						4625	455	17.243	
						5000	455	19.633	
						500	520	3.497	
						875	520	4.444	
						1250	520	5.084	
						1625	520	5.764	
						2000	520	7.205	
						2375	520	8.597	
						2750	520	10.135	
						3125	520	11.708	
						3500	520	12.962	
						3875	520	14.225	
						4250	520	15.647	
						4625	520	17.579	
						5000	520	20.031	
						500	585	5.179	
						875	585	5.962	
						1250	585	5.8	
						1625	585	6.341	
						2000	585	7.906	
						2375	585	9.452	
						2750	585	10.979	
						3125	585	13.019	
						3500	585	13.966	
						3875	585	15.661	
						4250	585	16.738	
						4625	585	17.935	
						5000	585	19.272	
						500	650	6.834	
						875	650	7.316	
						1250	650	5.632	
						1625	650	6.856	
						2000	650	8.471	
						2375	650	10.068	
						2750	650	11.671	
						3125	650	14.655	
						3500	650	14.804	
						3875	650	16.539	
						4250	650	18.415	
						4625	650	19.152	
						5000	650	20.33	

PART 1037— CONTROL OF EMISSIONS FROM NEW HEAVY-DUTY MOTOR VEHICLES

85. The authority citation for part 1037 continues to read as follows:
Authority: 42 U.S.C. 7401 - 7671q.

86. Amend §1037.1 by revising paragraph (a) to read as follows:

§ 1037.1 Applicability.

(a) ~~This part contains standards and other regulations applicable to the emission of the air pollutant defined as the aggregate group of six greenhouse gases: carbon dioxide, nitrous oxide, methane, hydrofluorocarbons, perfluorocarbons, and sulfur hexafluoride.~~ The regulations in this part 1037 apply for all new heavy-duty vehicles, except as provided in §§ 1037.5 and 1037.104. This includes electric vehicles, fuel cell vehicles, and vehicles fueled by conventional and alternative fuels. This also includes certain trailers as described in §§ 1037.5, 1037.150, and 1037.801.

* * * * *

87. Amend §1037.5 by revising paragraph (e) to read as follows:

§ 1037.5 Excluded vehicles.

* * * * *

(e) Vehicles subject to the heavy-duty ~~emission greenhouse gas~~ standards of 40 CFR part 86. See 40 CFR 86.1816 and 86.1819 for ~~emission greenhouse gas~~ standards that apply for these vehicles. This exclusion generally applies for complete heavy-duty vehicles at or below 14,000 pounds GVWR and all vehicles at or below 14,000 pounds GVWR that have no installed propulsion engine, such as electric vehicles.

* * * * *

88. Amend §1037.10 by revising paragraph (c) to read as follows:

§ 1037.10 How is this part organized?

* * * * *

(c) Subpart C of this part describes how to apply for a certificate of conformity ~~for vehicles subject to the standards of § 1037.105 or § 1037.106.~~

* * * * *

89. Revise §1037.101 to read as follows:

§ 1037.101 Overview of emission standards ~~for heavy-duty vehicles.~~

~~(a)~~ This part specifies emission standards for certain vehicles and for certain pollutants. This part contains standards and other regulations applicable to the emission of the air pollutant defined as the aggregate group of six greenhouse gases: carbon dioxide, nitrous oxide, methane, hydrofluorocarbons, perfluorocarbons, and sulfur hexafluoride.

~~(a)~~ You must show that vehicles meet the following emission standards: ~~The regulated emissions are addressed in four groups:~~

(1) Exhaust emissions of *criteria pollutants* ~~NO_x, HC, PM, and CO.~~ *Criteria pollutant standards for NO_x, HC, PM, and CO* apply as described in §1037.102. These pollutants are

sometimes described collectively as “criteria pollutants” because they are either criteria pollutants under the Clean Air Act or precursors to the criteria pollutants ozone and PM. ~~These pollutants are also sometimes described collectively as “non-greenhouse gas pollutants”, although they do not necessarily have negligible global warming potential. As described in § 1037.102, standards for these pollutants are provided in 40 CFR part 86.~~

(2) *Exhaust emissions of greenhouse gases CO_2 , CH_4 , and N_2O .* These pollutants are described collectively in this part as “greenhouse gas pollutants” because they are regulated primarily based on their impact on the climate. Emission standards apply as follows for greenhouse gas (GHG) emissions: ~~These standards are provided~~

(i) CO_2 , CH_4 , and N_2O emission standards apply as described in §§ 1037.105 through 1037.107.

(ii) Hydrofluorocarbon standards apply as described in § 1037.115. ~~(3)~~

~~Hydrofluorocarbons.~~ These pollutants are also “greenhouse gas pollutants” but are treated separately from exhaust greenhouse gas pollutants listed in paragraph (b)(2)(i) of this section. ~~These standards are provided in § 1037.115.~~

~~(34)~~ *Fuel evaporative emissions.* ~~These~~ Requirements related to fuel evaporative emissions are described in § 1037.103.

~~(e)~~ (b) The regulated heavy-duty vehicles are addressed in different groups as follows:

(1) For criteria pollutants, vocational vehicles and tractors are regulated based on gross vehicle weight rating (GVWR), whether they are considered “spark-ignition” or “compression-ignition,” and whether they are first sold as complete or incomplete vehicles.

(2) For greenhouse gas pollutants, vehicles are regulated in the following groups:

(i) Tractors above 26,000 pounds GVWR.

(ii) Trailers.

(iii) Vocational vehicles.

(3) The greenhouse gas emission standards apply differently depending on the vehicle service class as described in § 1037.140. In addition, standards apply differently for vehicles with spark-ignition and compression-ignition engines. References in this part 1037 to “spark-ignition” or “compression-ignition” generally relate to the application of standards under 40 CFR 1036.140. For example, a vehicle with an engine certified to spark-ignition standards under 40 CFR part 1036 is generally subject to requirements under this part 1037 that apply for spark-ignition vehicles. However, note that emission standards for ~~H~~heavy HDE~~heavy-duty engines~~ are considered to be compression-ignition standards for purposes of applying vehicle emission standards under this part. Also, for spark-ignition engines voluntarily certified as compression-ignition engines under 40 CFR part 1036, you must choose at certification whether your vehicles are subject to spark-ignition standards or compression-ignition standards. Heavy-duty vehicles with no installed propulsion engine, such as electric vehicles, are subject to compression-ignition emission standards for the purpose of calculating emission credits.

(4) For evaporative and refueling emissions, vehicles are regulated based on the type of fuel they use. Vehicles fueled with volatile liquid fuels or gaseous fuels are subject to evaporative emission standards. ~~Vehicles up to a certain size that are fueled with gasoline, diesel fuel, ethanol, methanol, or LPG are subject to refueling emission standards.~~

90. Revise §1037.102 to read as follows:

§ 1037.102 Exhaust emission standards for NO_x, HC, PM, and CO.

~~See 40 CFR part 86 for the exhaust emission standards for NO_x, HC, PM, and CO that apply for heavy-duty vehicles.~~

(a) Engines installed in heavy-duty vehicles are subject to criteria pollutant standards for NO_x, HC, PM, and CO under 40 CFR part 86 through model year 2026 and 40 CFR part 1036 for model years 2027 and later.

(b) Heavy-duty vehicles with no installed propulsion engine, such as electric vehicles, are subject to criteria pollutant standards under this part. The emission standards that apply are the same as the standards that apply for compression-ignition engines under 40 CFR 86.007-11 and 1036.104 for a given model year. Additional requirements apply to vehicles with no installed propulsion engine as specified in this part.

(1) Where this part references standards or other requirements in 40 CFR part 86 or 1036 that apply differently based on primary intended service class, apply the Light HDE provisions to Light HDV, apply the Medium HDE provisions to Medium HDV, and apply the Heavy HDE provisions to Heavy HDV.

(2) Criteria pollutant emission standards and related requirements apply for the useful life specified in 40 CFR 86.001-2 through model year 2026 and as specified in 40 CFR 1036.104 for model year 2027 and later. You may alternatively select the useful life values identified in §1037.105(e) if you do not generate NO_x credits under §1037.616.

(3) The following requirements apply for vehicles generating NO_x credits under §1037.616:

(i) *Electric vehicles.* Measure initial useable battery energy for electric vehicles using the test procedure in §1037.552. Useable battery energy must remain at or above 70 percent throughout the useful life.

(ii) *Fuel cell vehicles.* Measure initial fuel cell voltage for fuel cell vehicles using the test procedure in §1037.554. Fuel cell voltage must remain at or above 80 percent throughout the useful life.

91. Amend §1037.103 by:

- a. Revising paragraph (b)(1).
- b. Removing paragraph (b)(6).
- c. Revising paragraphs (f) and (g)(1) and (2).

The revisions read as follows:

§ 1037.103 Evaporative and refueling emission standards.

* * * * *

(b) * * *

(1) The refueling standards in 40 CFR 86.1813-17(b) apply to complete vehicles starting in model year 2022; they ~~are optional~~ apply for incomplete vehicles starting in model year 2027.

* * * * *

(f) *Useful life.* The evaporative and refueling emission standards of this section apply for the full useful life, expressed in service miles or calendar years, whichever comes first. The useful life values for the standards of this section are the same as the values described for evaporative emission standards in 40 CFR 86.1805.

(g) * * *

(1) Auxiliary engines and associated fuel-system components must be installed when testing ~~complete-fully assembled~~ vehicles. If the auxiliary engine draws fuel from a separate fuel tank, you must fill the extra fuel tank before the start of diurnal testing as described for the vehicle's main fuel tank. Use good engineering judgment to ensure that any nonmetal portions of the fuel system related to the auxiliary engine have reached stabilized levels of permeation emissions. The auxiliary engine must not operate during the running loss test or any other portion of testing under this section.

(2) For testing with ~~incomplete-partially assembled~~ vehicles, you may omit installation of auxiliary engines and associated fuel-system components as long as those components installed in the final configuration are certified to meet the applicable emission standards for Small SI equipment described in 40 CFR 1054.112 or for Large SI engines in 40 CFR 1048.105. For any fuel-system components that you do not install, your installation instructions must describe this certification requirement.

92. Amend §1037.105 by revising paragraphs (b)(1), (g)(2), and (h)(1) and (5)-(7) to read as follows:

§ 1037.105 CO₂ emission standards for vocational vehicles.

* * * * *

(b) * * *

(1) Model year 2027 and later vehicles are subject to CO₂ standards corresponding to the selected subcategories as shown in the following table:

Table 1 of § 1037.105—Phase 2 CO₂ Standards for Model Year 2027 and Later Vocational Vehicles (g/ton-mile)

Engine Cycle	Vehicle Size	Multi-Purpose	Regional	Urban
Compression-ignition	Light HDV	325 330	286 291	361 367
Compression-ignition	Medium HDV	231 235	215 218	254 258
Compression-ignition	Heavy HDV	226 230	186 189	265 269
Spark-ignition	Light HDV	372	319	413
Spark-ignition	Medium HDV	268	247	297

* * * * *

(g) * * *

(2) Class 8 hybrid vehicles with ~~L~~ight ~~HDE~~ or ~~M~~edium ~~HDE~~ ~~heavy-duty engines~~ may be certified to compression-ignition standards for the Heavy HDV service class. You may generate and use credits as allowed for the Heavy HDV service class.

* * * * *

(h) * * *

(1) The following alternative emission standards apply by vehicle type and model year as follows:

Table 5 of § 1037.105—Phase 2 Custom Chassis Standards (g/ton-mile)

Vehicle Type ^a	Assigned Vehicle Service Class	MY 2021-2026	MY 2027+
School bus	Medium HDV	291	267 271
Motor home	Medium HDV	228	226
Coach bus	Heavy HDV	210	205
Other bus	Heavy HDV	300	282 286
Refuse hauler	Heavy HDV	313	298
Concrete mixer	Heavy HDV	319	316
Mixed-use vehicle	Heavy HDV	319	316
Emergency vehicle	Heavy HDV	324	319

^aVehicle types are generally defined in § 1037.801. “Other bus” includes any bus that is not a school bus or a coach bus. A “mixed-use vehicle” is one that meets at least one of the criteria specified in § 1037.631(a)(1) or ~~(2) and at least one of the criteria in § 1037.631(a)(2), but not both.~~

* * * * *

(5) Emergency vehicles are deemed to comply with the standards of this paragraph (h) if they use tires with TRRL at or below 8.4 ~~kg/tonne~~N/kN (8.7 ~~N/kNg/tonne~~N/kNg/tonne for model years 2021 through 2026).

(6) Concrete mixers and mixed-use vehicles are deemed to comply with the standards of this paragraph (h) if they use tires with TRRL at or below 7.1 ~~kg/tonne~~N/kN (7.6 ~~N/kNg/tonne~~N/kNg/tonne for model years 2021 through 2026).

(7) Motor homes are deemed to comply with the standards of this paragraph (h) if they have tires with TRRL at or below 6.0 ~~kg/tonne~~N/kN (6.7 ~~N/kNg/tonne~~N/kNg/tonne for model years 2021 through 2026) and automatic tire inflation systems or tire pressure monitoring systems with wheels on all axles.

* * * * *

93. Amend §1037.106 by revising paragraphs (b) and (f)(1) to read as follows:

§ 1037.106 Exhaust emission standards for tractors above 26,000 pounds GVWR.

* * * * *

(b) The CO₂ standards for tractors above 26,000 pounds GVWR in Table 1 of this section apply based on modeling and testing as described in subpart F of this part. The provisions of § 1037.241 specify how to comply with these standards in this paragraph (b).

Table 1 of § 1037.106—CO₂ Standards for Class 7 and Class 8 Tractors by Model Year (g/ton-mile)

Subcategory ^a	Phase 1 Standards for Model Years 2014-2016	Phase 1 Standards for Model Years 2017-2020	Phase 2 Standards for Model Years 2021-2023	Phase 2 Standards for Model Years 2024-2026	Phase 2 Standards for Model Year 2027 and later
Class 7 Low-Roof (all cab styles)	107	104	105.5	99.8	94.8 96.2
Class 7 Mid-Roof (all cab styles)	119	115	113.2	107.1	101.8 103.4
Class 7 High-Roof (all cab styles)	124	120	113.5	106.6	98.5 98.5100.0
Class 8 Low-Roof Day Cab	81	80	80.5	76.2	72.3 73.4
Class 8 Low-Roof Sleeper Cab	68	66	72.3	68.0	64.1
Class 8 Mid-Roof Day Cab	88	86	85.4	80.9	76.8 78.0
Class 8 Mid-Roof Sleeper Cab	76	73	78.0	73.5	69.6
Class 8 High-Roof Day Cab	92	89	85.6	80.4	74.6 75.7
Class 8 High-Roof Sleeper Cab	75	72	75.7	70.7	64.3
Heavy-Haul Tractors	—	—	52.4	50.2	48.3

^aSub-category terms are defined in § 1037.801.

(f) * * *

(1) You may optionally certify 4×2 tractors with ~~H~~heavy ~~HDE~~heavy-duty engines to the standards and useful life for Class 8 tractors, with no restriction on generating or using emission credits within the Class 8 averaging set.

* * * * *

94. Amend §1037.115 by revising paragraphs (a) and (e)(3) to read as follows:

§ 1037.115 Other requirements.

* * * * *

(a) *Adjustable parameters.* Vehicles that have adjustable parameters must meet all the requirements of this part for any adjustment in the physically adjustable range. We may require that you set adjustable parameters to any specification within the adjustable range during any testing. ~~See 40 CFR 1068.50 for general provisions related to adjustable parameters. See 40 CFR 86.094-22 for information related to determining whether or not an operating parameter is considered adjustable.~~ You must ensure safe vehicle operation throughout the physically adjustable range of each adjustable parameter, including consideration of production tolerances.

Note that adjustable roof fairings and trailer rear fairings are deemed not to be adjustable parameters.

* * * * *

(e) * * *

(3) If air conditioning systems ~~with capacity above 3000 grams of refrigerant~~ are designed such that a compliance demonstration under 40 CFR 86.1867-12(a) is impossible or impractical, you may ask to use alternative means to demonstrate that your air conditioning system achieves an equivalent level of control.

95. Amend §1037.120 by revising paragraphs (b) and (c) to read as follows:

§ 1037.120 Emission-related warranty requirements.

* * * * *

(b) *Warranty period.* (1) Except as specified in paragraph (b)(2) of this section, yYour emission-related warranty must be valid for at least:

- (i) 5 years or 50,000 miles for Light HDV (except tires).
- (ii) 5 years or 100,000 miles for Medium HDV and Heavy HDV (except tires).
- (iii) 5 years for trailers (except tires).
- (iv) 1 year for tires installed on trailers, and 2 years or 24,000 miles for all other tires.

(2) Your emission-related warranty with respect to the standards under §1037.102(b) must be valid for at least the periods specified for engines in 40 CFR 1036.120(b) if you generate NO_x credits under §1037.616.

(3) You may offer an emission-related warranty more generous than we require. The emission-related warranty for the vehicle may not be shorter than any basic mechanical warranty you provide to that owner without charge for the vehicle. Similarly, the emission-related warranty for any component may not be shorter than any warranty you provide to that owner without charge for that component. This means that your warranty for a given vehicle may not treat emission-related and nonemission-related defects differently for any component. The warranty period begins when the vehicle is placed into service.

(c) *Components covered.* The emission-related warranty covers tires, automatic tire inflation systems, tire pressure monitoring systems, vehicle speed limiters, idle-reduction systems, hybrid system components, and devices added to the vehicle to improve aerodynamic performance (not including standard components such as hoods or mirrors even if they have been optimized for aerodynamics), to the extent such emission-related components are included in your application for certification. The emission-related warranty also covers other added emission-related components to the extent they are included in your application for certification. The emission-related warranty covers components designed to meet requirements under §1037.102(b)(3). The emission-related warranty covers all components whose failure would increase a vehicle's emissions of air conditioning refrigerants (for vehicles subject to air conditioning leakage standards), and it covers all components whose failure would increase a vehicle's evaporative and refueling emissions (for vehicles subject to evaporative and refueling emission standards). The emission-related warranty covers these components even if another company produces the component. Your emission-related warranty does not need to cover components whose failure would not increase a vehicle's emissions of any regulated pollutant.

* * * * *

96. Amend §1037.125 by revising paragraph (d) to read as follows:

§ 1037.125 Maintenance instructions and allowable maintenance.

* * * * *

(d) *Noncritical emission-related maintenance.* Subject to the provisions of this paragraph (d), you may schedule any amount of emission-related inspection or maintenance that is not covered by paragraph (a) of this section (that is, maintenance that is neither explicitly identified as critical emission-related maintenance, nor that we approve as critical emission-related maintenance). Noncritical emission-related maintenance generally includes maintenance on the components we specify in 40 CFR part 1068, aAppendix IA, that is not covered in paragraph (a) of this section. You must state in the owners manual that these steps are not necessary to keep the emission-related warranty valid. If operators fail to do this maintenance, this does not allow you to disqualify those vehicles from in-use testing or deny a warranty claim. Do not take these inspection or maintenance steps during service accumulation on your emission-data vehicles.

* * * * *

97. Amend §1037.130 by revising paragraph (b)(3) to read as follows:

§ 1037.130 Assembly instructions for secondary vehicle manufacturers.

* * * * *

(b) * * *

(3) Describe the necessary steps for installing emission-related any diagnostic systems required under 40 CFR part 86.

* * * * *

98. Amend §1037.135 by revising paragraph (c)(6) to read as follows:

§ 1037.135 Labeling.

* * * * *

(c) * * *

(6) Identify the emission control system. Use terms and abbreviations as described in aAppendix III-C to this part or other applicable conventions. Phase 2 tractors and Phase 2 vocational vehicles may omit this information.

* * * * *

99. Amend §1037.140 by revising paragraph (g) to read as follows:

§ 1037.140 Classifying vehicles and determining vehicle parameters.

* * * * *

(g) The standards and other provisions of this part apply to specific vehicle service classes for tractors and vocational vehicles as follows:

(1) Phase 1 and Phase 2 tractors are divided based on GVWR into Class 7 tractors and Class 8 tractors. Where provisions of this part apply to both tractors and vocational vehicles, Class 7 tractors are considered “Medium HDV” and Class 8 tractors are considered “Heavy HDV”. This paragraph (g)(1) applies for electric, hybrid, and non-hybrid vehicles.

(2) Phase 1 vocational vehicles are divided based on GVWR. “Light HDV” includes Class 2b through Class 5 vehicles; “Medium HDV” includes Class 6 and Class 7 vehicles; and “Heavy HDV” includes Class 8 vehicles.

(3) Phase 2 vocational vehicles propelled by engines subject to the spark-ignition standards of 40 CFR part 1036 are divided as follows: ~~“Light HDV” includes~~

(i) Class 2b through Class 5 vehicles are considered “Light HDV”; ~~and “Medium HDV” includes~~

(ii) Class 6 through Class 8 vehicles are considered “Medium HDV”.

(4) Phase 2 vocational vehicles propelled by engines subject to the compression-ignition standards in 40 CFR part 1036 are divided as follows:

(i) Class 2b through Class 5 vehicles are considered “Light HDV”.

(ii) Class 6 through 8 vehicles are considered “Heavy HDV” if the installed engine’s primary intended service class is ~~heavy heavy-duty~~ Heavy HDE (see 40 CFR 1036.140), except that ~~.(iii)~~ Class 8 hybrid ~~and electric~~ vehicles are considered “Heavy HDV”; regardless of the engine’s primary intended service class.

~~(iii)~~ (iv) All other Class 6 through Class 8 vehicles are considered “Medium HDV”.

(5) Heavy-duty vehicles with no installed propulsion engine, such as electric vehicles, are divided as follows:

(i) Class 2b through Class 5 vehicles are considered “Light HDV”.

(ii) Class 6 and 7 vehicles are considered “Medium HDV”.

(iii) Class 8 vehicles are considered “Heavy HDV”.

~~(5)~~ In certain circumstances, you may certify vehicles to standards that apply for a different vehicle service class. For example, see §§ 1037.105(g) and 1037.106(f). If you optionally certify vehicles to different standards, those vehicles are subject to all the regulatory requirements as if the standards were mandatory.

* * * * *

100. Amend §1037.150 by revising paragraphs (f) and (y)(1) to read as follows:

§ 1037.150 Interim provisions.

* * * * *

(f) *Electric and hydrogen fuel cell vehicles.* Tailpipe emissions of regulated GHG pollutants from electric vehicles and hydrogen fuel cell vehicles (as defined in § 1037.801) are deemed to be zero. No CO₂-related emission testing is required for electric vehicles. Use good engineering judgment to apply other requirements of this part to electric vehicles.

* * * * *

(y) * * *

(1) For vocational Light HDV and vocational Medium HDV, emission credits you generate in model years 2018 through 2021 may be used through model year 2027, instead of being limited to a five-year credit life as specified in § 1037.740(c). For Class 8 vocational vehicles with Mmedium HDEheavy-duty engines, we will approve your request to generate these credits in and use these credits for the Medium HDV averaging set if you show that these vehicles would qualify as Medium HDV under the Phase 2 program as described in § 1037.140(g)(4).

* * * * *

101. Amend §1037.205 by revising paragraphs (p) and (q) to read as follows:

§ 1037.205 What must I include in my application?

* * * * *

(p) Where applicable, describe all adjustable operating parameters (see § 1037.115), including production tolerances. For any operating parameters that do not qualify as adjustable parameters, include a description supporting your conclusion (see 40 CFR 1068.50(c)). You do not need to include parameters that do not affect emissions covered by your application. Include the following in your description of each adjustable parameter:

(1) For mechanically controlled parameters, include the nominal or recommended setting, the intended physically adjustable range, and the limits or stops used to establish adjustable ranges. Also include information showing why the limits, stops, or other means of inhibiting adjustment are effective in preventing adjustment of parameters on in-use engines to settings outside your intended physically adjustable ranges.

(2) For electronically controlled parameters, describe how your engines are designed to prevent unauthorized adjustments.

(q) ~~Reserved~~ Include the following information for electric vehicles and fuel cell vehicles to show that they meet the standards of this part:

(1) You may attest that vehicles comply with the standards of § 1037.102 instead of submitting test data.

(2) For vehicles generating credits under §1037.616, you may attest that the vehicle meets the durability requirements described in §1037.102(b)(3) based on an engineering analysis of measured values and other information, consistent with good engineering judgment, instead of testing at the end of the useful life. Send us your test results for work produced over the FTP and initial useable battery energy or initial fuel cell voltage. Also send us your engineering analysis describing how you meet the durability requirements if we ask for it.

* * * * *

102. Amend §1037.225 by revising the introductory text and paragraph (g) to read as follows:

§ 1037.225 Amending applications for certification.

Before we issue you a certificate of conformity, you may amend your application to include new or modified vehicle configurations, subject to the provisions of this section. After we have issued your certificate of conformity, you may send us an amended application any time before the end of the model year requesting that we include new or modified vehicle configurations within the scope of the certificate, subject to the provisions of this section. You must amend your application if any changes occur with respect to any information that is included or should be included in your application.

* * * * *

(g) You may produce vehicles or modify in-use vehicles as described in your amended application for certification and consider those vehicles to be in a certified configuration ~~if we approve a new or modified vehicle configuration during the model year under paragraph (d) of this section. Similarly, you may modify in-use vehicles as described in your amended application for certification and consider those vehicles to be in a certified configuration if we approve a new or modified vehicle configuration at any time under paragraph (d) of this section.~~ Modifying a new or in-use vehicle to be in a certified configuration does not violate the

tampering prohibition of 40 CFR 1068.101(b)(1), as long as this does not involve changing to a certified configuration with a higher family emission limit. See § 1037.621(g) for special provisions that apply for changing to a different certified configuration in certain circumstances.

103. Amend §1037.230 by revising paragraph (c) to read as follows:

§ 1037.230 Vehicle families, sub-families, and configurations.

* * * * *

(c) Group vehicles into configurations consistent with the definition of “vehicle configuration” in § 1037.801. Note that vehicles with hardware or software differences that are related to measured or modeled emissions are considered to be different vehicle configurations even if they have the same modeling inputs and FEL. Note also, that you are not required to separately identify all configurations for certification. Note that you are not required to identify all possible configurations for certification; also, you are required to include in your final ABT end-of-year report only those configurations you produced.

* * * * *

104. Amend §1037.231 by revising paragraph (b)(1) to read as follows:

§ 1037.231 Powertrain families.

* * * * *

(b) * * *

(1) Engine family as specified in 40 CFR 1036.230.

* * * * *

105. Amend §1037.250 by revising paragraph (a) to read as follows:

§ 1037.250 Reporting and recordkeeping.

(a) By September 30 following the end of the model year~~Within 90 days after the end of the model year~~, send the Designated Compliance Officer a report including the total U.S.-directed production volume of vehicles you produced in each vehicle family during the model year (based on information available at the time of the report). Report by vehicle identification number and vehicle configuration and identify the subfamily identifier. Report uncertified vehicles sold to secondary vehicle manufacturers. We may waive the reporting requirements of this paragraph (a) for small manufacturers.

* * * * *

106. Amend §1037.320 by removing Table 1 and revising paragraph (b) to read as follows:

§ 1037.320 Audit procedures for axles and transmissions.

* * * * *

(b) Run GEM for each applicable vehicle configuration and GEM regulatory subcategory identified in 40 CFR 1036.540 and for each vehicle class as defined in § 1037.140(g) using the applicable default engine map ~~defined~~ in appendix C of 40 CFR part 1036, the cycle-average fuel map in Table 1 of this section, and the ~~default~~ torque curve ~~given~~ in Table ~~2~~4 of this section for both the engine full-load torque curve and parent engine full-load torque curve, the motoring torque curve in Table 3 of this section, the idle fuel map in Table 4 of this section~~for the vehicle~~

~~class as defined in § 1037.140(g)~~. For axle testing, this may require omitting several vehicle configurations based on selecting axle ratios that correspond to the tested axle. For transmission testing, use the test transmission's gear ratios in place of the gear ratios defined in 40 CFR 1036.540. The GEM “Default FEL CO₂ Emissions” result for each vehicle configuration counts as a separate test for determining whether the family passes the audit. For vocational vehicles, use the GEM “Default FEL CO₂ Emissions” result for the Regional subcategory. Table 1 through Table 4 follow:

Table 1 to § 1037.320—Transient Cycle-Average Fuel Map by Vehicle Class

<u>Light HDV and Medium HDV— Spark-Ignition</u>					<u>Light HDV and Medium HDV— Compression-Ignition</u>					<u>Heavy HDV</u>				
<u>Engine Cycle Work (kW·hr)</u>	<u>N/V (r/min)</u>	<u>Fuel Mass (g)</u>	<u>Idle Speed (r/min)</u>	<u>Idle Torqu e (N·m)</u>	<u>Engine Cycle Work (kW·hr)</u>	<u>N/V (r/min)</u>	<u>Fuel Mass (g)</u>	<u>Idle Speed (r/min)</u>	<u>Idle Torqu e (N·m)</u>	<u>Engine Cycle Work (kW·hr)</u>	<u>N/V (r/min)</u>	<u>Fuel Mass (g)</u>	<u>Idle Speed (r/min)</u>	<u>Idle Torqu e (N·m)</u>
<u>3.5404</u>	<u>2.873 9</u>	<u>1109.3 1</u>	<u>600.5</u>	<u>37.99 7</u>	<u>3.3057</u>	<u>2.331 7</u>	<u>919.01</u>	<u>750.3</u>	<u>36.34 7</u>	<u>11.425 5</u>	<u>2.397 2</u>	<u>2579.5 8</u>	<u>600.7</u>	<u>89.65 8</u>
<u>3.6574</u>	<u>3.019 8</u>	<u>1153.3 5</u>	<u>600.4</u>	<u>37.95 1</u>	<u>3.3822</u>	<u>2.507 5</u>	<u>982.53</u>	<u>750.2</u>	<u>36.46 1</u>	<u>11.611 2</u>	<u>2.243 2</u>	<u>2591.0 8</u>	<u>601.2</u>	<u>90.42 8</u>
<u>3.8119</u>	<u>3.037 0</u>	<u>1188.6 6</u>	<u>600.2</u>	<u>37.95 6</u>	<u>3.4917</u>	<u>2.532 0</u>	<u>998.64</u>	<u>750.2</u>	<u>36.60 8</u>	<u>12.505 2</u>	<u>2.162 0</u>	<u>2763.2 8</u>	<u>602.4</u>	<u>92.01 4</u>
<u>4.0121</u>	<u>3.198 3</u>	<u>1250.7 6</u>	<u>600.1</u>	<u>38.15 3</u>	<u>3.6087</u>	<u>2.618 1</u>	<u>1036.3 4</u>	<u>750.2</u>	<u>36.73 4</u>	<u>17.774 7</u>	<u>2.519 5</u>	<u>3835.7 7</u>	<u>602.2</u>	<u>91.78 0</u>
<u>5.5567</u>	<u>3.132 5</u>	<u>1585.3 2</u>	<u>604.6</u>	<u>56.53 5</u>	<u>5.2397</u>	<u>2.505 0</u>	<u>1354.3 3</u>	<u>753</u>	<u>51.99 2</u>	<u>18.490 1</u>	<u>2.415 5</u>	<u>3994.2 9</u>	<u>603.5</u>	<u>93.72 4</u>
<u>5.6814</u>	<u>3.295 6</u>	<u>1639.0 8</u>	<u>604</u>	<u>56.54 9</u>	<u>5.3153</u>	<u>2.728 9</u>	<u>1417.2</u>	<u>751.9</u>	<u>51.48 8</u>	<u>20.190 4</u>	<u>2.380 0</u>	<u>4374.0 6</u>	<u>605.1</u>	<u>96.34 0</u>
<u>5.8720</u>	<u>3.325 5</u>	<u>1686.1 4</u>	<u>602.5</u>	<u>56.23 4</u>	<u>5.4112</u>	<u>2.668 9</u>	<u>1416.7 5</u>	<u>751.3</u>	<u>51.28 0</u>					
<u>6.1774</u>	<u>3.484 8</u>	<u>1773.3 9</u>	<u>601.7</u>	<u>56.03 8</u>	<u>5.5590</u>	<u>2.723 1</u>	<u>1450.6 7</u>	<u>751</u>	<u>51.25 4</u>					

Table 24 to § 1037.320—Default Full-Load Torque Curves by Vehicle Class

Light HDV and Medium HDV—Spark-Ignition		Light HDV <u>and Medium HDV—Compression-Ignition</u>		Heavy HDV	
Engine Speed (r/min)	Engine Torque (N·m)	Engine Speed (r/min)	Engine Torque (N·m)	Engine Speed (r/min)	Engine Torque (N·m)
600	433	750	470	600	1200
700	436	907	579	750	1320
800	445	1055	721	850	1490
900	473	1208	850	950	1700
1000	492	1358	876	1050	1950
1100	515	1507	866	1100	2090
1200	526	1660	870	1200	2100
1300	541	1809	868	1250	2100
1400	542	1954	869	1300	2093
1500	542	2105	878	1400	2092
1600	542	2258	850	1500	2085
1700	547	2405	800	1520	2075
1800	550	2556	734	1600	2010
1900	551	2600	0	1700	1910
2000	554			1800	1801
2100	553			1900	1640
2200	558			2000	1350
2300	558			2100	910
2400	566			2250	0
2500	571				
2600	572				
2700	581				
2800	586				
2900	587				
3000	590				
3100	591				
3200	589				
3300	585				
3400	584				
3500	582				
3600	573				
3700	562				
3800	555				
3900	544				
4000	534				
4100	517				
4200	473				
4291	442				
4500	150				

Table 3 to § 1037.320—Motoring Torque Curves by Vehicle Class

<u>Light HDV and Medium HDV—Spark-Ignition</u>		<u>Light HDV and Medium HDV—Compression-Ignition</u>		<u>Heavy HDV</u>	
<u>Engine Speed (r/min)</u>	<u>Engine Torque (N·m)</u>	<u>Engine Speed (r/min)</u>	<u>Engine Torque (N·m)</u>	<u>Engine Speed (r/min)</u>	<u>Engine Torque (N·m)</u>
<u>700</u>	<u>-41</u>	<u>750</u>	<u>-129</u>	<u>600</u>	<u>-98</u>
<u>800</u>	<u>-42</u>	<u>907</u>	<u>-129</u>	<u>750</u>	<u>-121</u>
<u>900</u>	<u>-43</u>	<u>1055</u>	<u>-130</u>	<u>850</u>	<u>-138</u>
<u>1000</u>	<u>-45</u>	<u>1208</u>	<u>-132</u>	<u>950</u>	<u>-155</u>
<u>1100</u>	<u>-48</u>	<u>1358</u>	<u>-135</u>	<u>1050</u>	<u>-174</u>
<u>1200</u>	<u>-49</u>	<u>1507</u>	<u>-138</u>	<u>1100</u>	<u>-184</u>
<u>1300</u>	<u>-50</u>	<u>1660</u>	<u>-143</u>	<u>1200</u>	<u>-204</u>
<u>1411</u>	<u>-51</u>	<u>1809</u>	<u>-148</u>	<u>1250</u>	<u>-214</u>
<u>1511</u>	<u>-52</u>	<u>1954</u>	<u>-155</u>	<u>1300</u>	<u>-225</u>
<u>1611</u>	<u>-53</u>	<u>2105</u>	<u>-162</u>	<u>1400</u>	<u>-247</u>
<u>1711</u>	<u>-56</u>	<u>2258</u>	<u>-170</u>	<u>1500</u>	<u>-270</u>
<u>1811</u>	<u>-56</u>	<u>2405</u>	<u>-179</u>	<u>1520</u>	<u>-275</u>
<u>1911</u>	<u>-57</u>	<u>2556</u>	<u>-189</u>	<u>1600</u>	<u>-294</u>
<u>2011</u>	<u>-57</u>			<u>1700</u>	<u>-319</u>
<u>2111</u>	<u>-58</u>			<u>1800</u>	<u>-345</u>
<u>2211</u>	<u>-60</u>			<u>1900</u>	<u>-372</u>
<u>2311</u>	<u>-65</u>			<u>2000</u>	<u>-400</u>
<u>2411</u>	<u>-81</u>			<u>2100</u>	<u>-429</u>
<u>2511</u>	<u>-85</u>				
<u>2611</u>	<u>-87</u>				
<u>2711</u>	<u>-88</u>				
<u>2811</u>	<u>-89</u>				
<u>2911</u>	<u>-91</u>				
<u>3011</u>	<u>-91</u>				
<u>3111</u>	<u>-96</u>				
<u>3211</u>	<u>-96</u>				
<u>3311</u>	<u>-97</u>				
<u>3411</u>	<u>-98</u>				
<u>3511</u>	<u>-99</u>				
<u>3611</u>	<u>-104</u>				
<u>3711</u>	<u>-105</u>				
<u>3811</u>	<u>-108</u>				
<u>3911</u>	<u>-108</u>				
<u>4011</u>	<u>-111</u>				
<u>4111</u>	<u>-111</u>				
<u>4211</u>	<u>-115</u>				
<u>4291</u>	<u>-112</u>				

Table 4 to § 1037.320—Engine Idle Fuel Maps by Vehicle Class

<u>Light HDV and Medium HDV— Spark-Ignition</u>			<u>Light HDV and Medium HDV— Compression-Ignition</u>			<u>Heavy HDV</u>		
<u>Engine Speed (r/min)</u>	<u>Engine Torque (N·m)</u>	<u>Fuel Mass Rate (g/s)</u>	<u>Engine Speed (r/min)</u>	<u>Engine Torque (N·m)</u>	<u>Fuel Mass Rate (g/s)</u>	<u>Engine Speed (r/min)</u>	<u>Engine Torque (N·m)</u>	<u>Fuel Mass Rate (g/s)</u>
<u>600</u>	<u>0</u>	<u>0.4010</u>	<u>750</u>	<u>0</u>	<u>0.2595</u>	<u>600</u>	<u>0</u>	<u>0.3501</u>
<u>700</u>	<u>0</u>	<u>0.4725</u>	<u>850</u>	<u>0</u>	<u>0.2626</u>	<u>700</u>	<u>0</u>	<u>0.4745</u>
<u>600</u>	<u>100</u>	<u>0.6637</u>	<u>750</u>	<u>100</u>	<u>0.6931</u>	<u>600</u>	<u>100</u>	<u>0.6547</u>
<u>700</u>	<u>100</u>	<u>0.7524</u>	<u>850</u>	<u>100</u>	<u>0.7306</u>	<u>700</u>	<u>100</u>	<u>0.8304</u>

* * * * *

107. Amend §1037.510 by revising paragraphs (a)(1)(i), (2), and (3) and (d) to read as follows:

§ 1037.510 Duty-cycle exhaust testing.

* * * * *

(a) * * *

(1) * * *

(i) *Transient cycle.* The transient cycle is specified in ~~a~~Appendix I-A of this part. Warm up the vehicle. Start the duty cycle within 30 seconds after concluding the preconditioning procedure. Start sampling emissions at the start of the duty cycle.

* * * * *

(2) Perform cycle-average engine fuel mapping as described in 40 CFR 1036.540. For powertrain testing under § 1037.550 or § 1037.555, perform testing as described in this paragraph (a)(2) to generate GEM inputs for each simulated vehicle configuration, and test runs representing different idle conditions. Perform testing as follows:

- (i) *Transient cycle.* The transient cycle is specified in ~~appendix I-A~~ of this part.
- (ii) *Highway cruise cycles.* The grade portion of the route corresponding to the 55 mi/hr and 65 mi/hr highway cruise cycles is specified in ~~appendix IV D~~ of this part. Maintain vehicle speed between -1.0 mi/hr and 3.0 mi/hr of the speed setpoint; this speed tolerance applies instead of the approach specified in 40 CFR 1066.425(b)(1) and (2).
- (iii) *Drive idle.* Perform testing at a loaded idle condition for Phase 2 vocational vehicles. For engines with an adjustable warm idle speed setpoint, test at the minimum warm idle speed and the maximum warm idle speed; otherwise simply test at the engine's warm idle speed. Warm up the powertrain ~~using the vehicle settings for the Test 1 vehicle configuration as defined in Table 2 or 3 of 40 CFR 1036.540 by operating it at 65 mi/hr for 600 seconds as described in 40 CFR 1036.527(c)(1).~~ Within 60 seconds after concluding the warm-up, linearly ramp the powertrain down to zero vehicle speed in over 20 seconds. Apply the brake and keep the transmission in drive (or clutch depressed for manual transmission). Set the engine to operate at idle speed. Stabilize the powertrain for (90-60 ±1) seconds and then, with the brake applied and the transmission in drive (or clutch depressed for manual transmission), and sample emissions to determine mean emission values (in g/s) over the last for (30 ±1) seconds of idling.
- (iv) *Parked idle.* Perform testing at an ~~unloaded no-load~~ idle condition for Phase 2 vocational vehicles. For engines with an adjustable warm idle speed setpoint, test at the minimum warm idle speed and the maximum warm idle speed; otherwise simply test at

the engine's warm idle speed. Warm up the powertrain as described in 40 CFR 1036.527(c)(1) using the vehicle settings for the Test 1 vehicle configuration by operating it at 65 mi/hr for 600 seconds. Within 60 seconds after concluding the warm-up, linearly ramp the powertrain down to zero vehicle speed in 20 seconds. Put the transmission in park (or neutral for manual transmissions and apply the parking brake if applicable). Stabilize Set the engine powertrain to operate at idle speed for for (1780 ±1) seconds, with the transmission in park (or the transmission in neutral with the parking brake applied for manual transmissions), and then sample emissions to determine mean emission values (in g/s) over the last for (600 ±1) seconds of idling.

(3) Where applicable, perform testing on a chassis dynamometer as follows:

- (i) *Transient cycle.* The transient cycle is specified in aAppendix I-A of this part. Warm up the vehicle by operating over one transient cycle. Within 60 seconds after concluding the warm up cycle, start emission sampling and operate the vehicle over the duty cycle.
- (ii) *Highway cruise cycle.* The grade portion of the route corresponding to the 55 mi/hr and 65 mi/hr highway cruise cycles is specified in aAppendix IV-D of this part. Warm up the vehicle by operating it at the appropriate speed setpoint over the duty cycle. Within 60 seconds after concluding the preconditioning cycle, start emission sampling and operate the vehicle over the duty cycle, maintaining vehicle speed within ±1.0 mi/hr of the speed setpoint; this speed tolerance applies instead of the approach specified in 40 CFR 1066.425(b)(1) and (2).

* * * * *

(d) For highway cruise and transient testing, compare actual second-by-second vehicle speed with the speed specified in the test cycle and ensure any differences are consistent with the criteria as specified in § 1037.550(g)(1)~~40 CFR 1066.425(b) and (c)~~. If the speeds do not conform to these criteria, the test is not valid and must be repeated.

* * * * *

108. Amend §1037.520 by revising paragraphs (c)(2) and (3), (f), and (h)(1) to read as follows:

§ 1037.520 Modeling CO₂ emissions to show compliance for vocational vehicles and tractors.

* * * * *

(c) * * *

(2) Measure tire rolling resistance in kg per metric ton as specified in ISO 28580 (incorporated by reference in § 1037.810), except as specified in this paragraph (c). Use good engineering judgment to ensure that your test results are not biased low. You may ask us to identify a reference test laboratory to which you may correlate your test results. Prior to beginning the test procedure in Section 7 of ISO 28580 for a new bias-ply tire, perform a break-in procedure by running the tire at the specified test speed, load, and pressure for (60 ±2) minutes.

(3) For each tire design tested, measure rolling resistance of at least three different tires of that specific design and size. Perform the test at least once for each tire. Calculate the arithmetic mean of these results to the nearest 0.1 kg/tonne~~N/kN~~ and use this value or any higher value as your GEM input for TRRL. You must test at least one tire size for each tire model, and may use engineering analysis to determine the rolling resistance of other tire sizes of that model. Note that for tire sizes that you do not test, we will treat your analytically derived rolling resistances the same as test results, and we may perform our own testing to

verify your values. We may require you to test a small sub-sample of untested tire sizes that we select.

* * * * *

(f) *Engine characteristics*. Enter information from the engine manufacturer to describe the installed engine and its operating parameters as described in 40 CFR 1036.503. ~~The fuel-mapping information must apply for the vehicle's GVWR; for example, if you install a medium heavy-duty engine in a Class 8 vehicle, the engine must have additional fuel-mapping information for the heavier vehicle.~~ Note that you do not need fuel consumption at idle for tractors.

* * * * *

(h) * * *

(1) For engines with no adjustable warm idle speed, input vehicle idle speed as the manufacturer's declared warm idle speed. For engines with adjustable warm idle speed, input your vehicle idle speed as follows:

If your vehicle is a...	And your engine is subject to...	Your default vehicle idle speed is... ^{a†}
(i) Heavy HDV	compression-ignition or spark-ignition standards	600 r/min.
(ii) Medium HDV tractor	compression-ignition standards	700 r/min.
(iii) Light HDV or Medium HDV vocational vehicle	compression-ignition standards	750 r/min.
(iv) Light HDV or Medium HDV	spark-ignition standards	600 r/min.

^{a†}If the default idle speed is above or below the engine manufacturer's whole range of declared warm idle speeds, use the manufacturer's maximum or minimum declared warm idle speed, respectively, instead of the default value.

* * * * *

109. Amend §1037.534 by revising paragraph (d)(2) to read as follows:

§ 1037.534 Constant-speed procedure for calculating drag area (C_dA).

* * * * *

(d) * * *

(2) Perform testing as described in paragraph (d)(3) of this section over a sequence of test segments at constant vehicle speed as follows:

- (i) $(300_{\pm 30})$ seconds in each direction at 10 mi/hr.
- (ii) $(450_{\pm 30})$ seconds in each direction at 70 mi/hr.
- (iii) $(450_{\pm 30})$ seconds in each direction at 50 mi/hr.
- (iv) $(450_{\pm 30})$ seconds in each direction at 70 mi/hr.
- (v) $(450_{\pm 30})$ seconds in each direction at 50 mi/hr.
- (vi) $(300_{\pm 30})$ seconds in each direction at 10 mi/hr.

* * * * *

110. Amend §1037.540 by revising the introductory text and paragraphs (b)(3), (7), and (8), and (f)(3) to read as follows:

§ 1037.540 Special procedures for testing vehicles with hybrid power take-off.

This section describes optional procedures for quantifying the reduction in greenhouse gas emissions for vehicles as a result of running power take-off (PTO) devices with a hybrid energy delivery system. See § 1037.550 for powertrain testing requirements that apply for drivetrain hybrid systems. The procedures are written to test the PTO by ensuring that the engine produces all of the energy with no net change in stored energy (charge-sustaining), and for plug-in hybrid vehicles, also allowing for drawing down the stored energy (charge-depleting). The full charge-sustaining test for the hybrid vehicle is from a fully charged ~~renewable~~ rechargeable energy storage system (RESS) to a depleted RESS and then back to a fully charged RESS. You must include all hardware for the PTO system. You may ask us to modify the provisions of this section to allow testing hybrid vehicles other than battery electric hybrids, consistent with good engineering judgment. For plug-in hybrids, use a utility factor to properly weight charge-sustaining and charge-depleting operation as described in paragraph (f)(3) of this section.

* * * * *

(b) * * *

- (3) Denormalize the PTO duty cycle in appendix ~~H~~B of this part using the following equation:

$$p_{refi} = p_i \cdot (\bar{p}_{max} - \bar{p}_{min}) + \bar{p}_{min}$$

Eq. 1037.540-1

Where:

p_{refi} = the reference pressure at each point i in the PTO cycle.

p_i = the normalized pressure at each point i in the PTO cycle (relative to \bar{p}_{max}).

\bar{p}_{max} = the mean maximum pressure measured in paragraph (b)(2) of this section.

\bar{p}_{min} = the mean minimum pressure measured in paragraph (b)(2) of this section.

* * * * *

- (7) Depending on the number of circuits the PTO system has, operate the vehicle over one or concurrently over both of the denormalized PTO duty cycles in ~~a~~Appendix B of this part. Measure emissions during operation over each duty cycle using the provisions of 40 CFR part 1066.

- (8) Measured pressures must meet the cycle-validation specifications in the following table for each test run over the duty cycle:

Table 1 of § 1037.540—Statistical Criteria for Validating Each Test Run Over the Duty Cycle

Parameter ^a	Pressure
Slope, a_1	$0.950 \leq a_1 \leq 1.030$.
Absolute value of intercept, $ a_0 $	≤ 2.0 % of maximum mapped pressure.
Standard error of the estimate, SEE	≤ 10 % of maximum mapped pressure.
Coefficient of determination, r^2	≥ 0.970 .

^aDetermine values for specified parameters as described in 40 CFR 1065.514(e) by comparing measured values to denormalized pressure values from the duty cycle in appendix ~~B~~H of this part.

* * * * *

(f) * * *

- (3) For plug-in hybrid electric vehicles calculate the utility factor weighted fuel consumption in g/ton-mile, as follows:

- (i) Determine the utility factor fraction for the PTO system from the table in appendix EV of this part using interpolation based on the total time of the charge-depleting portion of the test as determined in paragraphs (c)(6) and (d)(3) of this section.
- (ii) Weight the emissions from the charge-sustaining and charge-depleting portions of the test to determine the utility factor-weighted fuel mass, $m_{\text{fuelUF[cycle]plug-in}}$, using the following equation:

$$m_{\text{fuelPTOplug-in}} = \sum_{i=1}^N [m_{\text{fuelPTOCD}i} \cdot (UF_{\text{DCD}i} - UF_{\text{DCD}i-1})] + \sum_{j=1}^M [m_{\text{fuelPTOCS}j}] \cdot \frac{(1 - UF_{\text{RCD}})}{M}$$

~~$$m_{\text{fuelPTO,plug-in}} = m_{\text{PTO,CD}} \cdot UF_{\text{tCD}} + m_{\text{PTO,CS}} \cdot (1 - UF_{\text{tCD}})$$~~

Eq. 1037.540-3

Where:

i = an indexing variable that represents one test interval.

N = total number of charge-depleting test intervals.

$m_{\text{fuelPTOCD}}$ = total mass of fuel per ton-mile in the charge-depleting portion of the test for each test interval, i , starting from $i = 1$.

~~$m_{\text{PTO,CD}}$ = mass of fuel per ton-mile while in charge-depleting mode.~~

$UF_{\text{DCD}i}$ = utility factor fraction at time $t_{\text{CD}i}$ as determined in paragraph (f)(3)(i) of this section for each test interval, i , starting from $i = 1$.

~~$m_{\text{PTO,CS}}$ = mass of fuel per ton-mile while in charge-sustaining mode.~~ j = an indexing variable that represents one test interval.

M = total number of charge-sustaining test intervals.

$m_{\text{fuelPTOCS}}$ = total mass of fuel per ton-mile in the charge-sustaining portion of the test for each test interval, j , starting from $j = 1$.

UF_{RCD} = utility factor fraction at the full charge-depleting time, t_{CD} , as determined by interpolating the approved utility factor curve. t_{CD} is the sum of the time over N charge-depleting test intervals.

* * * * *

111. Revise §1037.550 to read as follows:

§ 1037.550 Powertrain testing.

This section describes the procedure to measure fuel consumption and create engine fuel maps by testing a powertrain that includes an engine coupled with a transmission, drive axle, and hybrid components or any assembly with one or more of those hardware elements. Engine fuel maps are part of demonstrating compliance with Phase 2 vehicle standards under this part; the powertrain test procedure in this section is one option for generating this fuel-mapping information as described in 40 CFR 1036.503. Additionally, this powertrain test procedure is one option for certifying hybrids to the engine standards in 40 CFR 1036.108.

(a) *General test provisions.* The following provisions apply broadly for testing under this section:

- (1) Measure NO_x emissions as described in paragraph (k) of this section. Include these measured NO_x values any time you report to us your greenhouse gas emissions or fuel consumption values from testing under this section.
- (2) The procedures of 40 CFR part 1065 apply for testing in this section except as specified. This section uses engine parameters and variables that are consistent with 40 CFR part 1065.

(3) Powertrain testing depends on models to calculate certain parameters. You can use the detailed equations in this section to create your own models, or use the GEM HIL model (incorporated by reference in § 1037.810) to simulate vehicle hardware elements as follows:

(i) Create driveline and vehicle models that calculate the angular speed setpoint for the test cell dynamometer, $f_{nref,dyno}$, based on the torque measurement location. Use the detailed equations in paragraph (f) of this section, the GEM HIL model's driveline and vehicle submodels, or a combination of the equations and the submodels. You may use the GEM HIL model's transmission submodel in paragraph (f) of this section to simulate a transmission only if testing hybrid engines.

(ii) Create a driver model or use the GEM HIL model's driver submodel to simulate a human driver modulating the throttle and brake pedals to follow the test cycle as closely as possible.

(iii) Create a cycle-interpolation model or use the GEM HIL model's cycle submodel to interpolate the duty-cycles and feed the driver model the duty-cycle reference vehicle speed for each point in the duty-cycle.

(4) The powertrain test procedure in this section is designed to simulate operation of different vehicle configurations over specific duty cycles. See paragraphs (h) and (j) of this section.

(5) For each test run, record engine speed and torque as defined in 40 CFR 1065.915(d)(5) with a minimum sampling frequency of 1 Hz. These engine speed and torque values represent a duty cycle that can be used for separate testing with an engine mounted on an engine dynamometer under § 1037.551, such as for a selective enforcement audit as described in § 1037.301.

(6) For hybrid powertrains with no plug-in capability, correct for the net energy change of the energy storage device as described in 40 CFR 1066.501. For [plug-in hybrid electric PHEV](#) powertrains, follow 40 CFR 1066.501 to determine End-of-Test for charge-depleting operation. You must get our approval in advance for your utility factor curve; we will approve it if you can show that you created it, [using good engineering judgment](#), from sufficient in-use data of vehicles in the same application as the vehicles in which the [plug-in hybrid electric PHEV](#) powertrain will be installed. [You may use methodologies described in SAE J2841 \(incorporated by reference in § 1037.810\) to develop the utility factor curve.](#)

[\(7\) The provisions related to carbon balance error verification in 40 CFR 1036.543 apply for all testing in this section. These procedures are optional if you are only performing direct or indirect fuel-flow measurement, but we will perform carbon balance error verification for all testing under this section.](#)

[\(8\) If you test a powertrain over the duty cycle specified in 40 CFR 1036.512, control and apply the electrical accessory loads using one of the following systems:](#)

[\(i\) An alternator with dynamic electrical load control.](#)

[\(ii\) A load bank connected directly to the powertrain's electrical system.](#)

(b) *Test configuration.* Select a powertrain for testing as described in § 1037.235 or 40 CFR 1036.235 as applicable. Set up the engine according to 40 CFR 1065.110 and 40 CFR 1065.405(b). Set the engine's idle speed to the minimum warm-idle speed. If warm idle speed is not adjustable, simply let the engine operate at its warm idle speed.

(1) The default test configuration consists of a powertrain with all components upstream of the axle. This involves connecting the powertrain's output shaft directly to the dynamometer or to a gear box with a fixed gear ratio and measuring torque at the axle input shaft. You may instead set up the dynamometer to connect at the wheel hubs and measure torque at that location. The preceding sentence may apply if your powertrain configuration requires it, such as for hybrid powertrains or if you want to represent the axle performance with powertrain test results.

(2) For testing hybrid engines, connect the engine's crankshaft directly to the dynamometer and measure torque at that location.

(c) *Powertrain temperatures during testing.* Cool the powertrain during testing so temperatures for oil, coolant, block, head, transmission, battery, and power electronics are within the manufacturer's expected ranges for normal operation. You may use electronic control module outputs to comply with this paragraph (c). You may use auxiliary coolers and fans.

(d) *Engine break in.* Break in the engine according to 40 CFR 1065.405, the axle assembly according to § 1037.560, and the transmission according to § 1037.565. You may instead break in the powertrain as a complete system using the engine break in procedure in 40 CFR 1065.405.

(e) *Dynamometer setup.* Set the dynamometer to operate in speed-control mode (or torque-control mode for hybrid engine testing at idle, including idle portions of transient duty cycles). Record data as described in 40 CFR 1065.202. Command and control the dynamometer speed at a minimum of 5 Hz, or 10 Hz for testing engine hybrids. Run the vehicle model to calculate the dynamometer setpoints at a rate of at least 100 Hz. If the dynamometer's command frequency is less than the vehicle model dynamometer setpoint frequency, subsample the calculated setpoints for commanding the dynamometer setpoints.

(f) *Driveline and vehicle model.* Use the GEM HIL model's driveline and vehicle submodels or the equations in this paragraph (f) to calculate the dynamometer speed setpoint, $f_{\text{ref},\text{dyno}}$, based on the torque measurement location. Note that the GEM HIL model is configured to set the accessory load to zero and it comes configured with the tire slip model disabled. Note that the GEM HIL model is configured to set the accessory load to zero and it comes configured with the tire slip model disabled.

(1) *Driveline model with a transmission in hardware.* For testing with torque measurement at the axle input shaft or wheel hubs, calculate, $f_{\text{ref},\text{dyno}}$, using the GEM HIL model's driveline submodel or the following equation:

$$f_{\text{ref},\text{dyno}} = \frac{k_{a[\text{speed}]} \cdot v_{\text{ref}i}}{2 \cdot \pi \cdot r_{[\text{speed}]}}$$

Eq. 1037.550-1

Where:

$k_{a[\text{speed}]}$ = drive axle ratio as determined in paragraph (h) of this section. Set $k_{a[\text{speed}]}$ equal to 1.0 if torque is measured at the wheel hubs.

$v_{\text{ref}i}$ = simulated vehicle reference speed as calculated in paragraph (f)(3) of this section.

$r_{[\text{speed}]}$ = tire radius as determined in paragraph (h) of this section.

(2) *Driveline model with a simulated transmission.* For testing with the torque measurement at the engine's crankshaft, $f_{\text{ref},\text{dyno}}$ is the dynamometer target speed from the GEM HIL model's transmission submodel. You may request our approval to change the transmission submodel, as long as the changes do not affect the gear selection logic. Before testing, initialize the transmission model with the engine's measured torque curve and the applicable steady-state fuel map from the GEM HIL model. You may request our approval to input your own steady-state fuel map. [For example, this request for approval could include using a fuel map that represents the combined performance of the engine and hybrid components.](#)

Configure the torque converter to simulate neutral idle when using this procedure to generate engine fuel maps in 40 CFR 1036.503 or to perform the Supplemental Emission Test (SET) testing under 40 CFR 1036.505. You may change engine commanded torque at idle to better represent CITT for transient testing under 40 CFR 1036.510. You may change the simulated engine inertia to match the inertia of the engine under test. We will evaluate your requests under this paragraph (f)(2) ~~of this section~~ based on your demonstration that that the adjusted testing better represents in-use operation.

(i) The transmission submodel needs the following model inputs:

- (A) Torque measured at the engine's crankshaft.
- (B) Engine estimated torque determined from the electronic control module or by converting the instantaneous operator demand to an instantaneous torque in N·m.
- (C) Dynamometer mode when idling (speed-control or torque-control).
- (D) Measured engine speed when idling.
- (E) Transmission output angular speed, $f_{ni,transmission}$, calculated as follows:

$$f_{ni,transmission} = \frac{k_{a[speed]} \cdot v_{refi}}{2 \cdot \pi \cdot r_{[speed]}}$$

Eq. 1037.550-2

Where:

$k_{a[speed]}$ = drive axle ratio as determined in paragraph (h) of this section.

v_{refi} = simulated vehicle reference speed as calculated in paragraph (f)(3) of this section.

$r_{[speed]}$ = tire radius as determined in paragraph (h) of this section.

- (ii) The transmission submodel generates the following model outputs:

- (A) Dynamometer target speed.
- (B) Dynamometer idle load.
- (C) Transmission engine load limit.
- (D) Engine speed target.

- (3) *Vehicle model.* Calculate the simulated vehicle reference speed, v_{refi} , using the GEM HIL model's vehicle submodel or the equations in this paragraph (f)(3):

$$v_{refi} = \left(\frac{k_a \cdot T_{i-1}}{r} \cdot (Eff_{axle}) - \left(M \cdot g \cdot C_{rr} \cdot \cos(\text{atan}(G_{i-1})) + \frac{\rho \cdot C_d A}{2} \cdot v_{ref,i-1}^2 \right) - F_{brake,i-1} - F_{grade,i-1} \right) \cdot \frac{\Delta t_{i-1}}{M + M_{rotating}} + v_{ref,i-1}$$

Eq. 1037.550-3

Where:

i = a time-based counter corresponding to each measurement during the sampling period. Let $v_{ref1} = 0$; start calculations at $i = 2$. A 10-minute sampling period will generally involve 60,000 measurements.

T = instantaneous measured torque at the axle input, measured at the wheel hubs, or simulated by the GEM HIL model's transmission submodel.

Eff_{axle} = axle efficiency. Use $Eff_{axle} = 0.955$ for $T \geq 0$, and use $Eff_{axle} = 1/0.955$ for $T < 0$. Use $Eff_{axle} = 1.0$ if torque is measured at the wheel hubs.

M = vehicle mass for a vehicle class as determined in paragraph (h) of this section.

g = gravitational constant = 9.80665 m/s².

C_{rr} = coefficient of rolling resistance for a vehicle class as determined in paragraph (h) of this section.

G_{i-1} = the percent grade interpolated at distance, D_{i-1} , from the duty cycle in appendix [D1V](#) to this part corresponding to measurement ($i-1$).

$$D_{i-1} = \sum_{i=1}^N (v_{ref,i-1} \cdot \Delta t_{i-1})$$

Eq. 1037.550-4

r = air density at reference conditions. Use $r = 1.1845$ kg/m³.

$C_d A$ = drag area for a vehicle class as determined in paragraph (h) of this section.

$F_{\text{brake},i-1}$ = instantaneous braking force applied by the driver model.

$$F_{\text{grade},i-1} = M \cdot g \cdot \sin(\text{atan}(G_{i-1}))$$

Eq. 1037.550-5

Δt = the time interval between measurements. For example, at 100 Hz, $\Delta t = 0.0100$ seconds.

M_{rotating} = inertial mass of rotating components. Let $M_{\text{rotating}} = 340$ kg for vocational Light HDV or vocational Medium HDV. See paragraph (h) of this section for tractors and for vocational Heavy HDV.

(4) *Example.* The following example illustrates a calculation of $f_{\text{ref,dyno}}$ using paragraph (f)(1) of this section where torque is measured at the axle input shaft. This example is for a vocational Light HDV or vocational Medium HDV with 6 speed automatic transmission at B speed (Test 4 in Table 12 of § 1037.55040 CFR 1036.540).

$$k_{aB} = 4.0$$

$$r_B = 0.399 \text{ m}$$

$$T_{999} = 500.0 \text{ N}\cdot\text{m}$$

$$C_{rr} = 7.7 \text{ kg/tonne N/kN} = 7.7 \cdot 10^{-3} \text{ kgN/kgN}$$

$$M = 11408 \text{ kg}$$

$$C_d A = 5.4 \text{ m}^2$$

$$G_{999} = 0.39 \% = 0.0039$$

$$D_{999} = \sum_{i=0}^{998} (19.99 \cdot 0.01 + 20.0 \cdot 0.01 + \dots + v_{\text{ref},998} \cdot \Delta t_{998}) = 1792 \text{ m}$$

$$F_{\text{brake},999} = 0 \text{ N}$$

$$v_{\text{ref},999} = 20.0 \text{ m/s}$$

$$F_{\text{grade},999} = 11408 \cdot 9.81 \cdot \sin(\text{atan}(0.0039)) = 436.5 \text{ N}$$

$$\Delta t = 0.0100 \text{ s}$$

$$M_{\text{rotating}} = 340 \text{ kg}$$

$$v_{\text{ref}1000} =$$

$$\left(\frac{4.0 \cdot 500.0}{0.399} \cdot (0.955) - \left((11408 \cdot 9.80665 \cdot 7.7 \cdot 10^{-3} \cdot \cos(\text{atan}(0.0039)) + \frac{1.1845 \cdot 5.4}{2} \cdot 20.0^2) - 0 - 436.5 \right) \right) \cdot \frac{0.0100}{11408 + 340} + 20.0 v_{\text{ref}1000} = 20.00189 \text{ m/s}$$

$$f_{\text{ref}1000,\text{dyno}} = \frac{4.0 \cdot 20.00189}{2 \cdot 3.14 \cdot 0.399} = 31.93 \text{ r/s} = 1915.8 \text{ r/min}$$

(g) *Driver model.* Use the GEM HIL model's driver submodel or design a driver model to simulate a human driver modulating the throttle and brake pedals. In either case, tune the model to follow the test cycle as closely as possible meeting the following specifications:

(1) The driver model must meet the following speed requirements:

(i) ~~F~~ for operation over the highway cruise cycles, the speed requirements as described in 40 CFR 1066.425(b) and (c).

(ii) ~~F§ 1037.510 and~~ for operation over the transient cycle specified in appendix A of this part, the SET as defined 40 CFR 1036.505, the Federal Test Procedure (FTP) as defined in 40 CFR 1036.510, and the Low Load Cycle (LLC) as defined in 40 CFR 1036.512, the speed requirements described as described in 40 CFR 1066.425(b) and (c).

(iii) ~~The exceptions in 40 CFR 1066.425(b)(4) apply to the transient cycle and the highway cruise cycles.~~ the transient cycle specified in appendix A of this part, SET, FTP, and LLC.

(iv) If the speeds do not conform to these criteria, the test is not valid and must be repeated.

(2) Send a brake signal when operator demand is zero and vehicle speed is greater than the reference vehicle speed from the test cycle. Include a delay before changing the brake signal to prevent dithering, consistent with good engineering judgment.

(3) Allow braking only if operator demand is zero.

(4) Compensate for the distance driven over the duty cycle over the course of the test. Use the following equation to perform the compensation in real time to determine your time in the cycle:

$$t_{\text{cycle}i} = \sum_{i=1}^N \left(\left(\frac{v_{\text{vehicle},i-1}}{v_{\text{cycle},i-1}} \right) \cdot \Delta t_{i-1} \right)$$

Eq. 1037.550-6

Where:

v_{vehicle} = measured vehicle speed.

v_{cycle} = reference speed from the test cycle. If $v_{\text{cycle},i-1} < 1.0$ m/s, set $v_{\text{cycle},i-1} = v_{\text{vehicle},i-1}$.

(h) *Vehicle configurations to evaluate for generating fuel maps as defined in 40 CFR 1036.503.*

Configure the driveline and vehicle models from paragraph (f) of this section in the test cell to test the powertrain. Simulate multiple vehicle configurations that represent the range of intended vehicle applications: using one of the following options:

(1) Use at least three equally spaced axle ratios or tire sizes and three different road loads (nine configurations), or at least four equally spaced axle ratios or tire sizes and two different road loads (eight configurations). Select axle ratios to represent the full range of expected vehicle installations. Instead of selecting axle ratios and tire sizes based on the range of intended vehicle applications as described in ~~this~~ paragraph (h)(2) of this section, you may select axle ratios and tire sizes such that the ratio of engine speed to vehicle speed covers the range of ratios of minimum and maximum engine speed to vehicle speed when the transmission is in top gear for the vehicles in which the powertrain will be installed. Note that you do not have to use the same axle ratios and tire sizes for each GEM regulatory subcategory. You may determine your own C_{rr} , C_{dA} , and M to cover the range of intended vehicle applications or you may use the road loads in paragraph (h)(2) of this section.

(2) Determine the vehicle model inputs for ~~M , M_{rotating} , C_{dA} , and C_{rr}~~ for a set of vehicle configurations as described in 40 CFR 1036.540(c)(3) with the following exceptions:

(i) In the equations of 40 CFR 1036.540(c)(3)(i), k_{topgear} is the actual top gear ratio of the powertrain instead of the transmission gear ratio in the highest available gear given in Table 1 of 40 CFR 1036.540.

(ii) Test at least eight different vehicle configurations for powertrains that will be installed in Spark-ignition HDE, vocational Light HDV, and vocational Medium HDV using the following table instead of Table 2 to 40 CFR 1036.540:

Table 1 to § 1037.550—Vehicle Configurations for Testing Spark-ignition HDE, Light HDE, and Medium HDE

	<u>Test 1</u>	<u>Test 2</u>	<u>Test 3</u>	<u>Test 4</u>	<u>Test 5</u>	<u>Test 6</u>	<u>Test 7</u>	<u>Test 8</u>
<u>C_{rr} (N/kN)</u>	<u>6.2</u>	<u>7.7</u>	<u>6.2</u>	<u>7.7</u>	<u>6.2</u>	<u>7.7</u>	<u>6.2</u>	<u>7.7</u>
<u>C_dA</u>	<u>3.4</u>	<u>5.4</u>	<u>3.4</u>	<u>5.4</u>	<u>3.4</u>	<u>5.4</u>	<u>3.4</u>	<u>5.4</u>
<u>CI engine speed for $\frac{f_{ntire}}{v_{vehicle}}$ and k_a</u>	<u>f_{nrefA}</u>	<u>f_{nrefA}</u>	<u>f_{nrefB}</u>	<u>f_{nrefB}</u>	<u>f_{nrefC}</u>	<u>f_{nrefC}</u>	<u>f_{ntest}</u>	<u>f_{ntest}</u>
<u>SI engine speed for $\frac{f_{ntire}}{v_{vehicle}}$ and k_a</u>	<u>f_{nrefD}</u>	<u>f_{nrefD}</u>	<u>f_{nrefA}</u>	<u>f_{nrefA}</u>	<u>f_{nrefB}</u>	<u>f_{nrefB}</u>	<u>f_{nrefC}</u>	<u>f_{nrefC}</u>
<u>M (kg)</u>	<u>7,257</u>	<u>11,408</u>	<u>7,257</u>	<u>11,408</u>	<u>7,257</u>	<u>11,408</u>	<u>7,257</u>	<u>11,408</u>
<u>$M_{rotating}$ (kg)</u>	<u>340</u>	<u>340</u>	<u>340</u>	<u>340</u>	<u>340</u>	<u>340</u>	<u>340</u>	<u>340</u>
<u>Drive Axle Configuration^a</u>	<u>4x2</u>	<u>4x2</u>	<u>4x2</u>	<u>4x2</u>	<u>4x2</u>	<u>4x2</u>	<u>4x2</u>	<u>4x2</u>
<u>GEM Regulatory Subcategory^a</u>	<u>LHD</u>	<u>MHD</u>	<u>LHD</u>	<u>MHD</u>	<u>LHD</u>	<u>MHD</u>	<u>LHD</u>	<u>MHD</u>

^aDrive axle configuration and GEM Regulatory Subcategory are not used if using the equations in paragraph (f)(3) of this section.

(iii) Select and test vehicle configurations as described in 40 CFR 1036.540(c)(3)(iii) for powertrains that will be installed in vocational Heavy HDV and tractors using the following tables instead of Table 3 and Table 4 of 40 CFR 1036.540:

Table 2 to § 1037.550—Vehicle Configurations for Testing General Purpose Tractors and Vocational Heavy HDV

	<u>Test 1</u>	<u>Test 2</u>	<u>Test 3</u>	<u>Test 4</u>	<u>Test 5</u>	<u>Test 6</u>	<u>Test 7</u>	<u>Test 8</u>	<u>Test 9</u>
<u>C_{rr} (N/kN)</u>	<u>6.9</u>	<u>6.9</u>	<u>6.9</u>	<u>6.9</u>	<u>6.9</u>	<u>6.9</u>	<u>6.9</u>	<u>6.9</u>	<u>6.9</u>
<u>C_{dA}</u>	<u>5.4</u>	<u>4.7</u>	<u>4.0</u>	<u>5.4</u>	<u>4.7</u>	<u>4.0</u>	<u>5.4</u>	<u>4.7</u>	<u>4.0</u>
<u>Engine speed for f_{ntire}, $v_{vehicle}$ and k_a</u>	<u>f_{nrefD}</u>	<u>f_{nrefD}</u>	<u>f_{nrefD}</u>	<u>f_{nrefB}</u>	<u>f_{nrefB}</u>	<u>f_{nrefB}</u>	<u>f_{ntest}</u>	<u>f_{ntest}</u>	<u>f_{ntest}</u>
<u>M (kg)</u>	<u>$\frac{31,97}{8}$</u>	<u>25,515</u>	<u>19,051</u>	<u>$\frac{31,97}{8}$</u>	<u>25,515</u>	<u>19,051</u>	<u>$\frac{31,97}{8}$</u>	<u>25,515</u>	<u>19,051</u>
<u>$M_{rotating}$ (kg)</u>	<u>1,021</u>	<u>794</u>	<u>794</u>	<u>1,021</u>	<u>794</u>	<u>794</u>	<u>1,021</u>	<u>794</u>	<u>794</u>
<u>Drive Axle Configuration^a</u>	<u>6x4</u>	<u>6x4</u>	<u>4x2</u>	<u>6x4</u>	<u>6x4</u>	<u>4x2</u>	<u>6x4</u>	<u>6x4</u>	<u>4x2</u>
<u>GEM Regulatory Subcategory^a</u>	<u>$\frac{C8_S}{C_HR}$</u>	<u>$\frac{C8_D}{C_MR}$</u>	<u>$\frac{C7_D}{C_MR}$</u>	<u>$\frac{C8_S}{C_HR}$</u>	<u>$\frac{C8_D}{C_MR}$</u>	<u>$\frac{C7_D}{C_MR}$</u>	<u>$\frac{C8_S}{C_HR}$</u>	<u>$\frac{C8_D}{C_MR}$</u>	<u>$\frac{C7_D}{C_MR}$</u>
<u>Vehicle Weight Reduction (lbs)</u>	<u>0</u>	<u>13,275</u>	<u>6,147</u>	<u>0</u>	<u>13,275</u>	<u>6,147</u>	<u>0</u>	<u>13,275</u>	<u>6,147</u>

^aDrive axle configuration and GEM Regulatory Subcategory are not used if using the equations in paragraph (f)(3) of this section.

Table 3 to § 1037.550—Vehicle Settings for Testing Heavy HDE Installed in Heavy-Haul Tractors

	<u>Test 1</u>	<u>Test 2</u>	<u>Test 3</u>	<u>Test 4</u>	<u>Test 5</u>	<u>Test 6</u>
<u>C_{rr} (N/kN)</u>	<u>6.9</u>	<u>6.9</u>	<u>6.9</u>	<u>6.9</u>	<u>6.9</u>	<u>6.9</u>
<u>C_{dA}</u>	<u>5.0</u>	<u>5.4</u>	<u>5.0</u>	<u>5.4</u>	<u>5.0</u>	<u>5.4</u>
<u>Engine speed for $\frac{f_{ntire}}{v_{vehicle}}$ and k_a</u>	<u>f_{nrefD}</u>	<u>f_{nrefD}</u>	<u>f_{nrefB}</u>	<u>f_{nrefB}</u>	<u>f_{ntest}</u>	<u>f_{ntest}</u>
<u>M (kg)</u>	<u>53,751</u>	<u>31,978</u>	<u>53,751</u>	<u>31,978</u>	<u>53,751</u>	<u>31,978</u>
<u>$M_{rotating}$ (kg)</u>	<u>1,021</u>	<u>1,021</u>	<u>1,021</u>	<u>1,021</u>	<u>1,021</u>	<u>1,021</u>
<u>Drive Axle Configuration^a</u>	<u>6x4</u>	<u>6x4</u>	<u>6x4</u>	<u>6x4</u>	<u>6x4</u>	<u>6x4</u>
<u>GEM Regulatory Subcategory^a</u>	<u>C8_HH</u>	<u>C8_SC_HR</u>	<u>C8_HH</u>	<u>C8_SC_HR</u>	<u>C8_HH</u>	<u>C8_SC_HR</u>

^aDrive axle configuration and GEM Regulatory Subcategory are not used if using the equations in paragraph (f)(3) of this section.

(3) For hybrid powertrain systems where the transmission will be simulated, use the transmission parameters defined in Table 1 of 40 CFR 1036.540 to determine transmission type and gear ratio. Use a fixed transmission efficiency of 0.95. The GEM HIL transmission model uses a transmission parameter file for each test that includes the transmission type, gear ratios, lockup gear, torque limit per gear from Table 1 of 40 CFR 1036.540, and the values from 40 CFR 1036.503(b)(4) and (c).

(i) [Reserved]

(j) *Duty cycles to evaluate.* Operate the powertrain over each of the duty cycles specified in § 1037.510(a)(2), and for each applicable vehicle configuration from paragraph (h) of this section. Determine cycle-average powertrain fuel maps by testing the powertrain using the procedures in 40 CFR 1036.540(d) with the following exceptions:

(1) Understand “engine” to mean “powertrain”.

(2) Warm up the powertrain as described in 40 CFR 1036.527(c)(1).

(3) Within 90 seconds after concluding the warm-up, start the transition to the preconditioning cycle as described in paragraph (j)(5) of this section.

(4) For plug-in hybrid engines, precondition the battery and then complete all back-to-back tests for each vehicle configuration according to 40 CFR 1066.501 before moving to the next vehicle configuration.

(5) If the preceding duty cycle does not end at 0 mi/hr, transition between duty cycles by decelerating at a rate of 2 mi/hr/s at 0 % grade until the vehicle reaches zero speed. Shut off the powertrain. Prepare the powertrain and test cell for the next duty-cycle.

~~(6) Start the next duty-cycle within 60 to 180 seconds after shutting off the powertrain. Do not run the powertrain or change its physical state before starting the next duty cycle. If the next duty cycle begins at 0 mi/hr vehicle speed~~

(i) To start the next duty-cycle, for hybrid powertrains, key on the vehicle and then start the duty-cycle. For conventional powertrains and start the duty cycle after 10 seconds, otherwise key on the vehicle, start the engine, wait for the engine to stabilize at idle speed, and then start the duty-cycle. and

(ii) If the duty-cycle does not start at 0 mi/hr, transition to the next duty cycle by accelerating at a target rate of 1 mi/hr/s at 0 % grade for vehicle configurations given in Table 2 of 40 CFR 1036.540 or 2 mi/hr/s at 0 % grade for vehicle configurations given in Tables 3 and 4 of 40 CFR 1036.540, then, Stabilize stabilize for 10 seconds at the initial duty cycle conditions and start the duty-cycle.

(73) Calculate cycle work using GEM or the speed and torque from the driveline and vehicle models from paragraph (f) of this section to determine the sequence of duty cycles.

(84) Calculate the mass of fuel consumed for idle duty cycles as described in paragraph (n) of this section.

~~(5) Warm up the powertrain as described in 40 CFR 1036.527(e)(1).~~

(k) *Measuring NO_x emissions.* Measure NO_x emissions for each sampling period in grams. You may perform these measurements using a NO_x emission-measurement system that meets the requirements of 40 CFR part 1065, subpart J. If a system malfunction prevents you from measuring NO_x emissions during a test under this section but the test otherwise gives valid results, you may consider this a valid test and omit the NO_x emission measurements; however, we may require you to repeat the test if we determine that you inappropriately voided the test with respect to NO_x emission measurement.

(l) [Reserved]

(m) *Measured output speed validation.* For each test point, validate the measured output speed with the corresponding reference values. If the range of reference speed is less than 10 percent of the mean reference speed, you need to meet only the standard error of the estimate in Table 1 of this section. You may delete points when the vehicle is stopped. If your speed measurement is not at the location of f_{nref} , correct your measured speed using the constant speed ratio between the two locations. Apply cycle-validation criteria for each separate transient or highway cruise cycle based on the following parameters:

Table 41 of § 1037.550 – Statistical Criteria for Validating Duty Cycles

Parameter ^a	Speed Control
Slope, a_1	$0.990 \leq a_1 \leq 1.010$.
Absolute value of intercept, $ a_0 $	≤ 2.0 % of maximum f_{nref} speed.
Standard error of the estimate, SEE	≤ 2.0 % of maximum f_{nref} speed.
Coefficient of determination, r^2	≥ 0.990 .

^aDetermine values for specified parameters as described in 40 CFR 1065.514(e) by comparing measured and reference values for $f_{nref,dyno}$.

(n) *Fuel consumption at idle.* Determine the mass of fuel consumed at idle for the applicable duty cycles described in § 1037.510(a)(2) as follows:

(1) Measure fuel consumption with a fuel flow meter and report the mean idle fuel mass flow rate for each duty cycle as applicable, $\bar{m}_{fuelidle}$.

(2) If you do not measure fuel mass flow rate, calculate the idle fuel mass flow rate for each duty cycle, $\bar{m}_{fuelidle}$, for each set of vehicle settings, as follows:

$$\bar{m}_{fuelidle} = \frac{M_C}{w_{Cmeas}} \cdot \left(\bar{n}_{exh} \cdot \frac{\bar{x}_{Ccombdry}}{1 + \bar{x}_{H2Oexhdry}} - \frac{\bar{m}_{CO2DEF}}{M_{CO2}} \right)$$

Eq. 1037.550-7

Where:

M_C = molar mass of carbon.

$w_{C_{meas}}$ = carbon mass fraction of fuel (or mixture of test fuels) as determined in 40 CFR 1065.655(d), except that you may not use the default properties in Table 24 of 40 CFR 1065.655 to determine α , b , and w_C for liquid fuels.

\bar{n}_{exh} = the mean raw exhaust molar flow rate from which you measured emissions according to 40 CFR 1065.655.

$\bar{x}_{C_{combdry}}$ = the mean concentration of carbon from fuel and any injected fluids in the exhaust per mole of dry exhaust.

$\bar{x}_{H_2O_{exhdry}}$ = the mean concentration of H₂O in exhaust per mole of dry exhaust.

\bar{m}_{CO_2DEF} = the mean CO₂ mass emission rate resulting from diesel exhaust fluid decomposition over the duty cycle as determined in 40 CFR 1036.535(b)(7). If your engine does not use diesel exhaust fluid, or if you choose not to perform this correction, set \bar{m}_{CO_2DEF} equal to 0.

M_{CO_2} = molar mass of carbon dioxide.

Example:

$M_C = 12.0107$ g/mol

$w_{C_{meas}} = 0.867$

$\bar{n}_{exh} = 25.534$ mol/s

$\bar{x}_{C_{combdry}} = 2.805 \cdot 10^{-3}$ mol/mol

$\bar{x}_{H_2O_{exhdry}} = 3.53 \cdot 10^{-2}$ mol/mol

$\bar{m}_{CO_2DEF} = 0.0726$ g/s

$M_{CO_2} = 44.0095$

$$\bar{m}_{fuel_{idle}} = \frac{12.0107}{0.867} \cdot \left(25.534 \cdot \frac{2.805 \cdot 10^{-3}}{1 + 3.53 \cdot 10^{-2}} - \frac{0.0726}{44.0095} \right)$$

$\bar{m}_{fuel_{idle}} = 0.405$ g/s = 1458.6 g/hr

(o) *Create GEM inputs.* Use the results of powertrain testing to determine GEM inputs for the different simulated vehicle configurations as follows:

(1) Correct the measured or calculated fuel masses, $m_{fuel[cycle]}$, and mean idle fuel mass flow rates, $\bar{m}_{fuel_{idle}}$, if applicable, for each test result to a mass-specific net energy content of a reference fuel as described in 40 CFR 1036.535(f), replacing \bar{m}_{fuel} with $m_{fuel[cycle]}$ where applicable in Eq. 1036.535-4.

(2) Declare fuel masses, $m_{fuel[cycle]}$, in g/cycle and $\bar{m}_{fuel_{idle}}$. Determine $m_{fuel[cycle]}$ using the calculated fuel mass consumption values described in 40 CFR 1036.540(d). In addition, declare mean fuel mass flow rate for each applicable idle duty cycle, $\bar{m}_{fuel_{idle}}$. These declared values may not be lower than any corresponding measured values determined in this section. If you use both direct and indirect measurement of fuel flow, determine the corresponding declared values as described in 40 CFR 1036.535(g)(2) and (3). If you use multiple measurement methods as allowed in 40 CFR 1036.540(d), follow 40 CFR 1036.535(g) regarding the use of direct and indirect fuel measurements and the carbon balance error verification. These declared values, which serve as emission standards, collectively represent the powertrain fuel map for certification.

(3) [Reserved] For engines designed for plug-in hybrid electric vehicles, the mass of fuel for each cycle, $m_{fuel[cycle]}$, is the utility factor-weighted fuel mass, $m_{fuelUF[cycle]}$. This is determined by calculating m_{fuel} for the full charge-depleting and charge-sustaining portions of the test and weighting the results, using the following equation:

$$m_{fuelUF[cycle]} = \sum_{i=1}^N [m_{fuel[cycle]CDi} \cdot (UF_{DCDi} - UF_{DCDi-1})] + \sum_{j=1}^M [m_{fuel[cycle]CSj}] \cdot \frac{(1 - UF_{RCD})}{M}$$

Eq. 1037.550-8

Where:

i = an indexing variable that represents one test interval.

N = total number of charge-depleting test intervals.

$m_{\text{fuel[cycle]CD}i}$ = total mass of fuel in the charge-depleting portion of the test for each test interval, i , starting from $i = 1$, including the test interval(s) from the transition phase.

$UF_{\text{DCD}i}$ = utility factor fraction at distance $D_{\text{CD}i}$ from Eq. 1037.505-9 as determined by interpolating the approved utility factor curve for each test interval, i , starting from $i = 1$. Let

$UF_{\text{DCD}0} = 0$

j = an indexing variable that represents one test interval.

M = total number of charge-sustaining test intervals.

$m_{\text{fuel[cycle]CS}j}$ = total mass of fuel over the charge-sustaining portion of the test for each test interval, j , starting from $j = 1$.

UF_{RCD} = utility factor fraction at the full charge-depleting distance, R_{CD} , as determined by interpolating the approved utility factor curve. R_{CD} is the cumulative distance driven over N charge-depleting test intervals.

$$D_{\text{CD}i} = \sum_{k=1}^Q (v_k \cdot \Delta t)$$

Eq. 1037.550-9

Where:

k = an indexing variable that represents one recorded velocity value.

Q = total number of measurements over the test interval.

v = vehicle velocity at each time step, k , starting from $k = 1$. For tests completed under this section, v is the vehicle velocity as determined by Eq. 1037.550-1. Note that this should include charge-depleting test intervals that start when the engine is not yet operating.

$\Delta t = 1/f_{\text{record}}$

f_{record} = the record rate.

Example for the 55 mi/hr cruise cycle:

$Q = 8790$

$v_1 = 55.0$ mi/hr

$v_2 = 55.0$ mi/hr

$v_3 = 55.1$ mi/hr

$f_{\text{record}} = 10$ Hz

$\Delta t = 1/10$ Hz = 0.1 s

$$D_{\text{CD}1} = \sum_{k=1}^{8790} (55.0 \cdot 0.1 + 55.0 \cdot 0.1 + 55.1 \cdot 0.1 + v_{8790} \cdot \Delta t) = 13.4 \text{ mi}$$

$D_{\text{CD}2} = 13.4$ mi

$D_{\text{CD}3} = 13.4$ mi

$N = 3$

$UF_{\text{DCD}1} = 0.05$

$UF_{\text{DCD}2} = 0.11$

$UF_{\text{DCD}3} = 0.21$

$m_{\text{fuel}55\text{cruiseCD}1} = 0$ g

$m_{\text{fuel}55\text{cruiseCD}2} = 0$ g

$m_{\text{fuel}55\text{cruiseCD}3} = 1675.4$ g

$$M = 1$$

$$m_{\text{fuel55cruiseCS}} = 4884.1 \text{ g}$$

$$UF_{\text{RCD}} = 0.21$$

$$m_{\text{fuelUF55cruise}} = [0 \cdot (0.05 - 0) + 0 \cdot (0.11 - 0.05) + 1675.4 \cdot (0.21 - 0.11)] + 4884.1 \cdot \frac{(1 - 0.21)}{1} = 4026.0 \text{ g}$$

(43) Calculate powertrain output speed per unit of vehicle speed, $\left[\frac{\bar{f}_{\text{npowertrain}}}{\bar{v}_{\text{powertrain}}} \right]_{\text{cycle}}$, using one

of the following methods:

(i) For testing with torque measurement at the axle input shaft:

$$\left[\frac{\bar{f}_{\text{npowertrain}}}{\bar{v}_{\text{powertrain}}} \right]_{\text{cycle}} = \frac{k_a}{2 \cdot \pi \cdot r_{\text{speed}}}$$

Eq. 1037.550-810

Example:

$$k_a = 4.0$$

$$r_B = 0.399 \text{ m}$$

$$\left[\frac{\bar{f}_{\text{npowertrain}}}{\bar{v}_{\text{powertrain}}} \right]_{\text{transienttest4}} = \frac{4.0}{2 \cdot 3.14 \cdot 0.399} = 1.596 \text{ r/m}$$

(ii) For testing with torque measurement at the wheel hubs, use Eq. 1037.550-8 setting k_a equal to 1.

(iii) For testing with torque measurement at the engine's crankshaft:

$$\left[\frac{\bar{f}_{\text{npowertrain}}}{\bar{v}_{\text{powertrain}}} \right]_{\text{cycle}} = \frac{\bar{f}_{\text{nengine}}}{\bar{v}_{\text{ref}}}$$

Eq. 1037.550-119

Where:

\bar{f}_{nengine} = average engine speed when vehicle speed is at or above 0.100 m/s.

\bar{v}_{ref} = average simulated vehicle speed at or above 0.100 m/s.

Example:

$$\bar{f}_{\text{nengine}} = 1870 \text{ r/min} = 31.17 \text{ r/s}$$

$$\bar{v}_{\text{ref}} = 19.06 \text{ m/s}$$

$$\left[\frac{\bar{f}_{\text{npowertrain}}}{\bar{v}_{\text{powertrain}}} \right]_{\text{transienttest4}} = \frac{31.17}{19.06} = 1.635 \text{ r/m}$$

(54) Calculate positive work, W_{cycle} , as the work over the duty cycle at the axle input shaft, wheel hubs, or the engine's crankshaft, as applicable, when vehicle speed is at or above 0.100 m/s. For plug-in hybrids engines and powertrains, calculate, W_{cycle} , by calculating the positive work over each of the charge-sustaining and charge-depleting test intervals and then averaging them together.

(56) Calculate engine idle speed, by taking the average engine speed measured during the transient cycle test while the vehicle speed is below 0.100 m/s.

(67) The following table illustrates the GEM data inputs corresponding to the different vehicle configurations for a given duty cycle:

Table 52 of § 1037.550 – Example Vehicle Configuration Test Result Output Matrix for Heavy HDV

	VEHICLE CONFIGURATION NUMBER								
	1	2	3	4	5	6	7	8	9
$m_{\text{fuel[cycle]}}$									
$\left[\frac{\bar{f}_{\text{powertrain}}}{\bar{v}_{\text{powertrain}}} \right]_{\text{cycle}}$									
W_{cycle}									
$\bar{f}_{\text{idle}}^{\text{a}}$									

^aIdle speed applies only for the transient duty cycle.

112. Amend §1037.551 by revising the introductory text and paragraphs (b) and (c) to read as follows:

§ 1037.551 Engine-based simulation of powertrain testing.

Section 1037.550 describes how to measure fuel consumption over specific duty cycles with an engine coupled to a transmission; § 1037.550(a)(5) describes how to create equivalent duty cycles for repeating those same measurements with just the engine. This § 1037.551 describes how to perform this engine testing to simulate the powertrain test. These engine-based measurements may be used for confirmatory testing as described in § 1037.235, or for selective enforcement audits as described in § 1037.301, as long as the test engine’s operation represents the engine operation observed in the powertrain test. If we use this approach for confirmatory testing, when making compliance determinations, we will consider the uncertainty associated with this approach relative to full powertrain testing. Use of this approach for engine SEAs is optional for engine manufacturers.

* * * * *

(b) Operate the engine over the applicable engine duty cycles corresponding to the vehicle cycles specified in § 1037.510(a)(2) for powertrain testing over the applicable vehicle simulations described in § 1037.550(j). Warm up the engine to prepare for the transient test or one of the highway cruise cycles by operating it one time over one of the simulations of the corresponding duty cycle. Warm up the engine to prepare for the idle test by operating it over a simulation of the 65-mi/hr highway cruise cycle for 600 seconds. Within 60 seconds after concluding the warm up cycle, start emission sampling while the engine operates over the duty cycle. You may perform any number of test runs directly in succession once the engine is warmed up. Perform cycle validation as described in 40 CFR 1065.514 for engine speed, torque, and power.

(c) Calculate the mass of fuel consumed as described in § 1037.550(m) and (o). Correct each measured value for the test fuel’s mass-specific net energy content as described in 40 CFR 1036.530. Use these corrected values to determine whether the engine’s emission levels conform to the declared fuel-consumption rates from the powertrain test.

113. Add a new §1037.552 to subpart F to read as follows:

§ 1037.552 Multicycle powertrain test for battery electric vehicles.

This section describes a procedure to measure work produced over the Heavy-Duty Transient Cycle (HDTC), useable battery energy (UBE) of a powertrain that propels a battery electric vehicle, and a transient cycle conversion factor, CF_{BEV} , for use in § 1037.616. Work produced over the HDTC and UBE are part of demonstrating compliance with criteria pollutant standards

under § 1037.102 if you choose to generate NO_x emission credits under this part. This test procedure is one option for generating work produced over the HDTC and UBE. You may ask to use alternative test methods to demonstrate compliance with the standards.

(a) General test provisions. The following provisions apply broadly for testing under this section:

(1) The procedures of 40 CFR part 1065 apply for testing in this section except as specified. This section uses engine parameters and variables that are consistent with 40 CFR part 1065.

(2) For powertrains that propel a battery electric vehicle, follow the procedures of 40 CFR 1036.505, 1036.510, and 1036.512 for testing the respective duty-cycles in this section except as specified. For the purposes of testing under this section, testing over the HDTC is carried out using the transient duty cycle described in 40 CFR 1036.510(a)(2) with a cold start testing only being required for the first HDTC of the test sequence.

(3) The following instruments are required for determination of the required voltages and currents during testing and must be installed on the powertrain to measure these values during testing:

(i) Measure the voltage and current of the battery pack directly with a DC wideband voltage, Ampere, and Watt-hour meter (power analyzer). Install this meter in such a way as to measure all current leaving and entering the battery pack (no other connections upstream of the measurement point). The maximum integration period for ampere-hour meters using an integration technique is 0.05 seconds to accommodate abrupt current changes without introducing significant integration errors. Use a power analyzer that has an accuracy for current and voltage measurements of 1% of point or 0.3% of max, whichever is greater. Use an instrument that is not susceptible to offset errors while measuring current as very small current offsets can be integrated throughout the cycle and provide erroneous energy or ampere-hour results.

(ii) If voltage sensing is not available, then optionally measure amp hours without directly measuring voltage using a DC wideband ampere-hour meter. In this case, the voltage is determined from the powertrain ECM.

(iii) Install an AC Watt-hour meter to measure AC recharge energy in such a way as to measure all AC electrical energy entering the powertrain charger. Use an AC Watt-hour meter that has an accuracy for current and voltage measurements of 1% of point or 0.3% of max, whichever is greater.

(4) You must include in the test the powertrains cooling system (e.g. battery, power electronics, and electric motor(s)) such that the energy used from these accessories is accounted for during the test, including the pre- and post- test soak and charging periods.

(5) Stabilize powertrains tested under this section by following manufacturer recommendations.

(i) For determining the initial UBE, test a powertrain that has accumulated a minimum of 1000 miles, but no more than 6200 miles using a manufacturer defined durability driving schedule. Age the battery as follows:

(A) Include it in the powertrain that was operated over the durability driving schedule.

(B) Condition it using test procedure #2, Constant Current Discharge Test Series, in the United States Advanced Battery Consortium Electric Vehicle Battery Test Procedures Manual, Revision 2 (incorporated by reference in § 1037.810). Note that the number of charge/discharge cycles for bench aging a lead acid battery must be equivalent to at least 1000 vehicle miles. You may use other battery aging periods for non-lead-acid battery technologies, if supported by the manufacturer as being equivalent.

(ii) For determining aged UBE, test a powertrain that has accumulated targeted aged miles.

(6) Cycle all batteries in accordance with the powertrain manufacturers' recommendations before starting testing.

(b) Precondition the powertrain by repeatedly operating it over the HDTC, without soaks and leaving the key in the on position between cycles, until the powertrain's battery is fully depleted. This method is recommended to ensure that the subsequent recharge event produces a repeatable battery energy capacity prior to the test; however, a preconditioning sequence that does not fully deplete the battery but consists of at least one HDTC is also acceptable if it results in equivalent pre-test UBE.

(c) Following the preconditioning, soak the powertrain, including the battery and thermal management system, if any, at (20 to 30) °C for 12 to 36 hours. Charge the powertrain for the duration of the soak period measuring the DC recharge energy, E_{DCRC} , and do not end the soak period prior to reaching full charge. Upon completion of the soak, install the powertrain, if not already installed, in the test cell and attach it to the dynamometer. The powertrain will be tested in a cold start condition for this test. Start the powertrain test no more than one hour after the powertrain is taken off charge.

(d) Measure DC discharge energy, E_{DCD} , in Watt-hours and DC discharge current per hour, C_D , for the entire Multicycle Test (MCT). The measurement points for the battery(ies) must capture all the current flowing into and out of the battery(ies) during powertrain operation, including current associated with regenerative braking. The equation for calculating powertrain E_{DCD} is given in Eq. 1037.552-1, however, it is expected that this calculation will typically be performed internally by the power analyzer specified in paragraph (a)(3)(i) of this section. Battery voltage measurements made by the powertrain's own on-board sensors (such as those available via a diagnostic port) may be used for calculating E_{DCD} if these measurements are equivalent to those produced by applicable external measurement equipment, such as a power analyzer.

$$E_{DCD} = \frac{1}{3600 \cdot f} \cdot \sum_{i=0}^N V_i \cdot I_i$$

Eq. 1037.552-1

Where:

f = frequency of the current measurement in Hz.

i = an indexing variable that represents one individual measurement.

N = total number of measurements.

V = battery DC bus voltage in volts.

I = battery current in amps.

(e) The MCT range test consists of four HDTCs, two LLCs, two SETs, and two constant speed cycles: CSC_M at the mid-test point and CSC_E at the end of test.

(1) The test sequence follows: HDTC-HDTC-LLC-SET- CSC_M -HDTC-HDTC-LLC-SET- CSC_E .

(2) The CSC is used to rapidly deplete battery energy, and consists of a steady-state speed schedule of 55 mi/hr or 90% of maximum sustainable speed if a powertrain cannot reach 55 mi/hr. When transitioning from the SET to CSC, smoothly accelerate to 55 mi/hr within 1 minute of the key switch being placed in the "on" position. Maintain powertrain speed to within ± 1.0 mi/hr of the speed setpoint.

(3) Use one of the following methods to determine the duration of CSC_M , t_{CSCM} , prior to carrying out the test sequence:

(i) DC recharge energy method. This method requires data from the recharge event preceding the test as described in paragraph (b) of this section or known UBE, cycle DC discharge energy, $E_{DCD[dutycycle]}$, and DC energy consumption rates, EC , measured either before or during the MCT.

(A) If a reasonable estimate of the powertrain's UBE is not available, determine UBE_{est} as follows:

$$UBE_{est} = B_{eff} \cdot E_{DCRC}$$

Eq. 1037.552-2

Where:

B_{eff} = estimated battery efficiency = 0.95. You may develop your own estimated battery efficiency.

E_{DCRC} = DC recharge energy measured during the pre-test recharging event. If DC recharge energy is not available, use the AC recharge energy, E_{ACRC} , from the pre-test recharging event which includes the total AC energy supplied to the powertrain from the electrical grid, including all energy used to power charging equipment (e.g., charger, electrical vehicle supply equipment, 12V battery charger, etc.), and define a suitable (lower) battery plus charger efficiency factor to calculate UBE_{est} .

Example:

$$E_{DCRC} = 600000 \text{ W}\cdot\text{hrs}$$

$$B_{eff} = 0.95$$

$$UBE_{est} = 0.95 \cdot 600000 = 570000 \text{ W}\cdot\text{hrs}$$

(B) Determine length of CSC_M , D_{CSCM} , using the following equation:

$$D_{CSCM} = \frac{CSC_{Mfactor} \cdot UBE_{est} - 4 \cdot E_{DCDHDTC} - 2 \cdot E_{DCDLLC} - 2 \cdot E_{DCDSET}}{EC_{CSC}}$$

Eq. 1037.552-3

Where:

$CSC_{Mfactor}$ = multiplier intended to leave 10 % of the total energy for $CSC_E = 0.9$. You may choose a smaller factor, but target no more than 20 % of the total energy for CSC_E .

$E_{DCDHDTC}$ = discharge energy from HDTC #2 of the MCT.

E_{DCDLLC} = discharge energy from LLC #1 of the MCT.

E_{DCDSET} = discharge energy from SET #1 of the MCT.

EC_{CSC} = DC energy consumption from the preconditioning run in paragraph (b) of this section.

Example:

$$E_{DCDHDTC} = 25604 \text{ W}\cdot\text{hr}$$

$$E_{DCDLLC} = 37312 \text{ W}\cdot\text{hr}$$

$$E_{DCDSET} = 129009 \text{ W}\cdot\text{hr}$$

$$EC_{CSC} = 1380 \text{ W}\cdot\text{hr}/\text{mi}$$

$$CSC_{Mfactor} = 0.9$$

$$D_{CSCM} = \frac{0.9 \cdot 570000 - 4 \cdot 25604 - 2 \cdot 37312 - 2 \cdot 129009}{1380} = 56.5 \text{ mi}$$

(C) Determine t_{CSCM} using the following equation:

$$t_{CSCM} = \frac{D_{CSCM}}{v_{CSC}}$$

Eq. 1037.552-4

Where:

v_{CSC} = powertrain speed over the CSC = 55 mi/hr.

Example:

$$t_{CSCM} = \frac{56.5}{55} = 1.02 \text{ hrs}$$

(ii) Projected range method. Use this method if the DC cycle discharge energy and DC recharge energy are unknown. Determine CSC_M using the powertrain's projected range on the HDTC, LLC, SET, and CSC.

(A) Using the powertrain's projected range and distance on the duty cycle(s), determine D_{CSCM} as follows:

$$D_{CSCM} = R_{CSCest} - 4 \cdot D_{HDTC} \cdot \frac{R_{CSCest}}{R_{HDTCest}} - 2 \cdot D_{LLC} \cdot \frac{R_{CSCest}}{R_{LLCest}} - 2 \cdot D_{SET} \cdot \frac{R_{CSCest}}{R_{SETest}} - CSC_{Efactor} \cdot R_{CSCest}$$

Eq. 1037.552-5

Where:

R_{CSCest} = estimated range from the charge depleting test run in paragraph (e)(2) of this section.

$R_{HDTCest}$ = estimated range on repeat HDTC cycles determine in paragraph (k) of this section.

R_{LLCest} = estimated range on repeat LLC cycles determine in paragraph (k) of this section.

R_{SETest} = estimated range on repeat SET cycles determine in paragraph (k) of this section.

D_{HDTC} = scheduled driving distance of one HDTC = 6.75 miles.

D_{LLC} = scheduled driving distance of one LLC = 15.70 miles.

D_{SET} = scheduled driving distance of one SET = 35.47 miles.

$CSC_{Efactor}$ = multiplier intended to leave 20 % of the total energy for $CSC_E = 0.2$.

You may choose a smaller factor if your range estimates allow for accurate determination of the factor.

Example:

$R_{CSCest} = 413.0$ miles

$R_{HDTCest} = 180.3$ miles

$R_{LLCest} = 299.8$ miles

$R_{SETest} = 156.7$ miles

$D_{HDTC} = 6.75$ miles

$D_{LLC} = 15.70$ miles

$D_{SET} = 35.47$ miles

$CSC_{Efactor} = 0.2$

$$D_{CSCM} = 413.0 - 4 \cdot 6.75 \cdot \frac{413.0}{180.3} - 2 \cdot 15.70 \cdot \frac{413.0}{299.8} - 2 \cdot 35.47 \cdot \frac{413.0}{156.7} - 0.2 \cdot 413.0 = 38.4 \text{ mi}$$

(B) Determine t_{CSCM} using Eq. 1037.552-4.

Example:

$$t_{CSCM} = \frac{38.4}{55} = 0.7 \text{ hrs}$$

(4) Operate the powertrain over the test sequence described in Figure 1 of § 1037.552. Measure and report the total work, W_{cycle} , E_{DCD} , and C_D from each of the test intervals. During soaks, use test cell ventilation to maintain a the powertrain soak temperature of (20 to 30) °C with the key or power switch in the “off” position and the brake pedal not depressed.

Figure 1 of § 1037.552—MCT Test Sequence

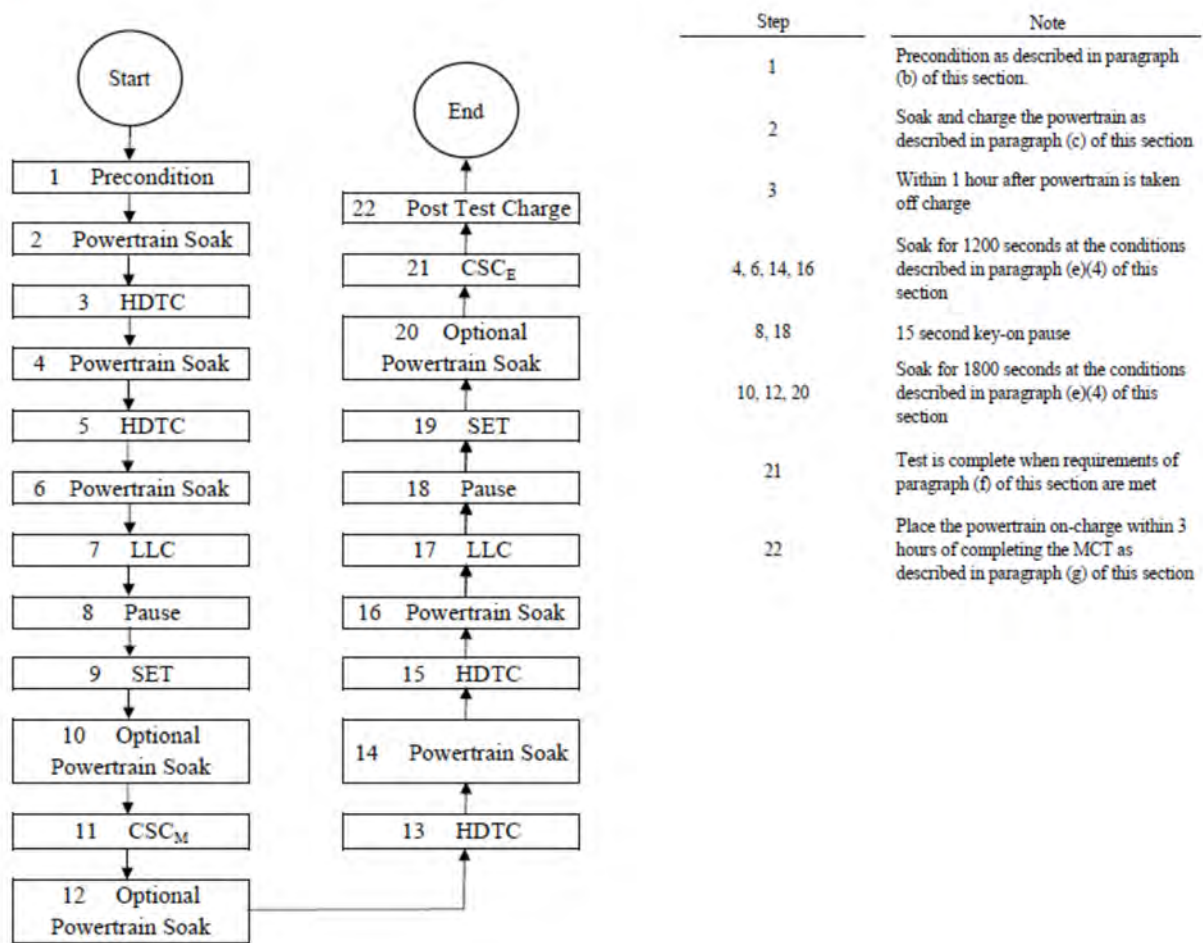

(f) The test is complete when the following end-of-test criteria during CSC_E have been met.
 (1) The test termination criterion for the full-depletion range and energy consumption test for powertrains capable of meeting the prescribed speed vs. time relationship of the applicable drive cycle follows:
 (i) The test is complete when the powertrain, due to power limitations, is incapable of maintaining ±1.0 mi/hr of the speed setpoint or the manufacturer determines that the test

should be terminated for safety reasons (e.g., excessively high battery temperature, abnormally low battery voltage, etc.).

(ii) Immediately apply the brake and decelerate the powertrain to a stop within 15 seconds once the test termination criteria have been met.

(2) The test termination criterion for the full-depletion range and energy consumption test for powertrains that are not capable of meeting the prescribed speed vs. time relationship of the applicable drive cycle for the initial phase of that cycle (i.e., the phase that begins with the powertrain fully-charged) and operated at maximum available power follows:

(i) The test is complete when the powertrain, while operated at maximum available power or “full throttle”, is unable to reproduce the best-effort speed vs. time relationship established by the powertrain in the first phase of the test.

(ii) The best-effort trace drive tolerance are the speed requirements described in 40 CFR 1066.425(b)(1) and (2).

(g) Place the powertrain on-charge within 3 hours of completing the MCT and charge the battery to full capacity to measure the total AC recharge energy, E_{ACRC} , and DC recharge current per hour, C_{RC} .

(1) Carryout recharging at the same nominal ambient temperature as the pre-test soak/charging period.

(2) Established that the system is fully charged using the manufacturer’s recommended charging procedure and appropriate equipment. Use the powertrain charger if it came equipped with one. Otherwise, charge the powertrain using an external charger recommended by the powertrain manufacturer. If multiple charging power levels are available, recharge the powertrain at the power level recommended by the manufacturer. If the manufacturer does not specify a power level, recharging the system at the power level expected to be most widely used by end users. Use this power level for all pre- and post-test recharging events.

(3) Measure all AC energy supplied to the powertrain from the electrical grid, including all energy used to power charging equipment (e.g., charger, electrical vehicle supply equipment, 12V battery charger, etc.).

(4) Determine E_{AC} in Watt-hours and C_C in amp hours, using the instruments specified in paragraph (a)(3) of this section, for powertrains that require less than 12 hours to reach full charge by measuring the E_{AC} and C_C for a 12 hour period following the connection of the powertrain to the electrical vehicle supply equipment.

(5) Collect data for powertrains requiring more than 12 hours to reach full charge, until full charge is achieved. Note that the 12 hour minimum data collection period is intended to better replicate expected in-use charging practices (i.e., overnight charging) and to provide a standard time period that can be used quantify any ancillary recharging loads, such as those resulting from battery thermal conditioning.

(6) Charge recovery is used to evaluate the equivalence of the pre- and post-test charge. Since the net amp-hours required to return the battery to a full charge during the post MCT recharging event in paragraph (g)(1) of this section must be greater than or equal to net amp hours discharged by the battery during the MCT, the charge recovery ratio should be ≥ 1 for most battery types. Since the determination of full charge verification must also take into account error in the associated measurement devices, the pre- and post- test charge events can be considered equivalent if the charge recovery is greater than 0.97. Verify the charge recovery, CR , of the post-test battery charge as follows:

$$CR = \frac{|C_{DCRC}|}{|C_{DCD}|} \geq 0.97$$

Eq. 1037.552-6

Where:

C_{DCRC} = total post-MCT DC recharge current per hour.

C_{DCD} = total DC discharge current per hour during the MCT.

Example:

$C_{DCRC} = 1425.0$ amp·hrs

$C_{DCD} = 1452.1$ amp·hrs

$$CR = \frac{|1425.0|}{|1452.1|} = 0.98$$

(h) The UBE is defined as the total DC discharge energy, $E_{DCDtotal}$, measured in DC Watt hours, over the MCT as determined as described in paragraph (d) of this section. The UBE represents the total deliverable energy the battery is capable of providing while a powertrain is following a duty cycle on a dynamometer. Determine a declared UBE that is at or below the corresponding value determined in paragraph (d) of this section, including those from redundant measurements. This declared UBE serves as the initial UBE that must be submitted under § 1037.205(q)(2).

(i) [Reserved]

(j) Determine the transient cycle conversion factor, CF_{BEV} , in hp·hr/mile. This represents the average work performed over the test interval for use in the credit calculation for battery electric vehicles in § 1037.616.

$$CF_{BEV} = \frac{W_{HDTC2}}{d}$$

Eq. 1037.552-7

Where:

W_{HDTC2} = total (integrated) work generated over the second HDTC test interval in the MTC.

d = duty-cycle distance for engines subject to compression-ignition standards from the CF determination for the emission credit calculation in 40 CFR 1036.705 = 6.5 miles.

Example:

$W_{HDTC2} = 32.62$ hp·hr

$d = 6.5$ miles

$$CF_{BEV} = \frac{32.62}{6.5} = 5.02 \text{ hp} \cdot \text{hr}/\text{mi}$$

(k) If you use the projected range option for determining the duration of CSC_M , t_{CSCM} , in paragraph (e)(3)(ii) of this section, determine the total range and energy consumption for a BEV over the HDTC, LLC, and SET when operated on a dynamometer over repeats of a respective duty-cycle. This is a single cycle test (SCT) where the powertrain is driven until the useable energy content of the powertrain's battery is fully depleted. The intent of this section is to provide a standard powertrain procedure for testing BEVs so that their performances can be compared when operated over the certification duty cycles. Measure C_D as described in paragraph (d) of this section during the entire dynamometer test procedure (duty cycles and soaks) in order to validate the equivalence of the pre- and post-test charge.

(1) Precondition and soak the powertrain prior to testing as described in paragraphs (b) and (c) of this section.

(2) Operate the powertrain over one of the following drive cycles:

(i) HDTC.

(ii) LLC.

(iii) SET.

(3) Operate the powertrain over one of the duty-cycles described in paragraph (k)(2) of this section using the following soak times between each duty-cycle. Soak the powertrain as described in paragraph (e)(4) of this section.

(i) HDTC. 10 to 30 minutes between each duty-cycle.

(ii) LLC. A 15 second key on pause.

(iii) SET. A 15 second key on pause.

(4) Repeat testing over the duty cycle until the end-of-test criteria in paragraph (f) of this section have been met. You may specify other earlier test termination criterion, for example, to prevent battery damage. In this case, you may specify a battery characteristic such as terminal voltage under load to be the test termination criterion.

(5) Place the powertrain on-charge within 3 hours of completing the SCT and charge the battery to full capacity as described in paragraph (g) of this section.

(6) The range for an SCT, R_{cycle} , is defined as the total test distance driven in miles from the beginning of the test until the point where the powertrain reaches zero speed after satisfying the end-of-test criteria.

114. Add a new §1037.554 to subpart F to read as follows:

§ 1037.554 Multicycle powertrain test for fuel cell vehicles.

This section describes a procedure to measure work produced over the heavy-duty transient cycle (HDTC) and fuel cell voltage (FCV) of a powertrain that propels a fuel cell vehicle. Work produced over the HDTC and FCV are part of demonstrating compliance with criteria pollutant standards under § 1037.102 if you choose to generate NO_x emission credits under this part. This test procedure is one option for generating work produced over the HDTC and FCV. You may ask to use alternative test methods to demonstrate compliance with the standards.

(a) The following provisions apply broadly for testing under this section:

(1) The procedures of 40 CFR part 1065 apply for testing in this section except as specified. This section uses engine parameters and variables that are consistent with 40 CFR part 1065.

(2) For powertrains that propel a fuel cell vehicle, follow the procedures of 40 CFR 1036.505, 1036.510, and 1036.512 for testing the respective duty-cycles in this section except as specified.

(3) Use the instruments in § 1037.552(a)(3)(i) and (ii) for determination of the required voltages and currents during testing and install these on the powertrain to measure these values during testing.

(4) Stabilize powertrains tested under this section by following manufacturer recommendations.

(i) For determining the initial mean fuel cell voltage, \overline{FCV} , test a powertrain that has accumulated a minimum of 1000 miles, but no more than 6200 miles using a manufacturer defined durability driving schedule.

(ii) For determining aged \overline{FCV} , test a powertrain that has accumulated targeted aged miles.

(b) Operate the powertrain over the SET, FTP, and LLC as defined in 40 CFR 1036.505, 40 CFR 1036.510(a)(2), and 40 CFR 1036.512, while measuring FCV and fuel cell current (FCC) upstream of any RESS, if present.

(c) Determine \overline{FCV} , by taking the mean of the FCV when the FCC is between 55 % and 65 % of rated stack current, using the data collected in paragraph (b) of this section. Determine a

declared \overline{FCV} that is at or below the corresponding value determined in this paragraph (c). This declared \overline{FCV} serves as the FCV that must be submitted under § 1037.205(q)(2).

(d) Determine the transient cycle conversion factor, CF_{FCEV} , in hp·hr/mile. This represents the average work performed over the test interval for use in the credit calculation for fuel cell vehicles in § 1037.616.

$$CF_{FCEV} = \frac{W_{HDTC}}{D}$$

Eq. 1037.554-1

Where:

W_{HDTC} = total (integrated) work generated over the hot-start HDTC test interval from the FTP test.

D = duty-cycle distance for engine subject to compression-ignition standards from the CF determination for the emission credit calculation in 40 CFR 1036.705 = 6.5 miles.

Example:

$W_{HDTC} = 31.71$ hp·hr

$D = 6.5$ miles

$$CF_{FCEV} = \frac{31.71}{6.5} = 4.88 \text{ hp} \cdot \text{hr}/\text{mi}$$

115. Amend §1037.555 by revising paragraph (g) to read as follows:

§ 1037.555 Special procedures for testing Phase 1 hybrid systems.

* * * * *

(g) The driver model should be designed to follow the cycle as closely as possible and must meet the requirements of § 1037.510 for steady-state testing and 40 CFR 1066.42530(e) for transient testing. The driver model should be designed so that the brake and throttle are not applied at the same time.

* * * * *

116. Amend §1037.601 by revising paragraph (a)(1) to read as follows:

§ 1037.601 General compliance provisions.

(a) * * *

(1) Except as specifically allowed by this part or 40 CFR part 1068, it is a violation of §40 CFR 1068.101(a)(1) to introduce into U.S. commerce a tractor or vocational vehicle that is not certified to the applicable requirements of this part. Similarly, it is a violation of 40 CFR 1068.101(a)(1) to introduce into U.S. commerce a tractor or vocational vehicle containing an engine that is not certified to the applicable requirements of this part and 40 CFR part 86 or 1036. Further, it is a violation to introduce into U.S. commerce a Phase 1 tractor containing an engine not certified for use in tractors; or to introduce into U.S. commerce a vocational vehicle containing a Light HDE heavy-duty or Medium HDE heavy-duty engine not certified for use in vocational vehicles. These prohibitions apply especially to the vehicle manufacturer. Note that this paragraph (a)(1) allows the use of Heavy heavy-duty tractor engines in vocational vehicles.

* * * * *

117. Amend §1037.605 by revising paragraphs (a) introductory text and (a)(4) to read as follows:

§ 1037.605 Installing engines certified to alternate standards for specialty vehicles.

(a) *General provisions.* This section allows vehicle manufacturers to introduce into U.S. commerce certain new motor vehicles using engines certified to alternate emission standards specified in 40 CFR ~~1036.605~~~~part 86~~ for motor vehicle engines used in specialty vehicles. You may not install an engine certified to these alternate standards if there is an engine certified to the full set of requirements of 40 CFR part ~~1036~~~~86~~ that has the appropriate physical and performance characteristics to power the vehicle. Note that, although these alternate emission standards are mostly equivalent to standards that apply for nonroad engines under 40 CFR part 1039 or 1048, they are specific to motor vehicle engines. ~~The alternate standards for compression-ignition engines at or above 56 kW are described in 40 CFR 86.007-11(g); the alternate standards for spark-ignition engines are described in 40 CFR 86.008-10(g).~~ The provisions of this section apply for the following types of specialty vehicles:

* * * * *

(4) Through model year 2027, vehicles with a hybrid powertrain in which the engine provides energy only for the Rechargeable Energy Storage System.

* * * * *

118. Amend §1037.615 by revising paragraph (f) to read as follows:

§ 1037.615 Advanced technologies.

* * * * *

(f) For electric vehicles and for fuel cells powered by hydrogen, calculate CO₂ credits using an FEL of 0 g/ton-mile. Note that these vehicles are subject to compression-ignition standards for CO₂.

* * * * *

119. Add a new §1037.616 to subpart G to read as follows:

§ 1037.616 NO_x credits for electric vehicles and fuel cell vehicles.

Starting in model year 2024, electric vehicles and fuel cell vehicles may generate NO_x credits for certifying heavy-duty engines under 40 CFR part 1036 as follows:

(a) Calculate NO_x credits as described in 40 CFR 1036.705 based on the following values:

- (1) Select a useful life value as specified in §1037.102(b).
- (2) Select the family emission limit that represents the NO_x emission standards that the vehicle will meet throughout the vehicle's useful life.
- (3) Use the NO_x emission standard that applies as specified in §1037.102(b) for engines tested over the FTP duty cycle corresponding to the vehicle's model year.
- (4) For "volume", use the number of vehicles generating emission credits within each averaging set specified in §1037.740 during the model year.
- (5) Determine a conversion factor, *CF*, in hp·hr/mile using the procedures specified in §§1037.552 and 1037.554.

(b) You may use NO_x credits generated under this section as specified in 40 CFR 1036.741.

120. Amend §1037.635 by revising paragraph (b)(2) to read as follows:

§ 1037.635 Glider kits and glider vehicles.

* * * * *

(b) * * *

(2) The engine must meet the criteria pollutant standards of 40 CFR part 86 or part 1036 that apply for the engine model year corresponding to the vehicle's date of manufacture.

* * * * *

121. Amend §1037.705 by revising paragraph (b) to read as follows:

§ 1037.705 Generating and calculating emission credits.

* * * * *

(b) For each participating family or subfamily, calculate positive or negative emission credits relative to the otherwise applicable emission standard. Calculate positive emission credits for a family or subfamily that has an FEL below the standard. Calculate negative emission credits for a family or subfamily that has an FEL above the standard. Sum your positive and negative credits for the model year before rounding. Round the sum of emission credits to the nearest megagram (Mg), using consistent units with the following equation:

$$Emission\ credits\ (Mg) = (Std_FEL) \cdot (PL) \cdot (Volume) \cdot (UL) \cdot (10^{-6})$$

Where:

Std = the emission standard associated with the specific regulatory subcategory (g/ton-mile).

FEL = the family emission limit for the vehicle subfamily (g/ton-mile).

PL = standard payload, in tons.

Volume = U.S.-directed production volume of the vehicle subfamily. For example, if you produce three configurations with the same FEL, the subfamily production volume would be the sum of the production volumes for these three configurations.

UL = useful life of the vehicle, in miles, as described in § 1037.105 and § 1037.106. Use 250,000 miles for trailers.

* * * * *

122. Amend §1037.725 by revising the section heading to read as follows:

§ 1037.725 Required information for certification. ~~What must I include in my application for certification?~~

* * * * *

123. Amend §1037.730 by revising paragraphs (a), (b) introductory text, (c), and (f) to read as follows:

§ 1037.730 ABT reports.

(a) If you certify any ~~of your vehicle engine~~ families ~~are certified~~ using the ABT provisions of this subpart, ~~you must send us an end-of-year report by March 31 following the end of the model year and~~ a final report by September 30 following the end of the model year. ~~We may waive the requirement to send an end-of-year report.~~

(b) Your ~~end-of-year and final~~ reports must include the following information for each vehicle family participating in the ABT program:

* * * * *

(c) Your ~~end-of-year and final~~ reports must include the following additional information:

(1) Show that your net balance of emission credits from all your participating vehicle families in each averaging set in the applicable model year is not negative, except as allowed under § 1037.745. Your credit tracking must account for the limitation on credit life under § 1037.740(c).

(2) State whether you will retain any emission credits for banking. If you choose to retire emission credits that would otherwise be eligible for banking, identify the families that generated the emission credits, including the number of emission credits from each family.
(3) State that the report's contents are accurate.

(4) Identify the technologies that make up the certified configuration associated with each vehicle identification number. You may identify this as a range of identification numbers for vehicles involving a single, identical certified configuration.

* * * * *

(f) Correct errors in your ~~end-of-year or final~~ report as follows:

(1) ~~You may correct any errors in your end-of-year report when you prepare the final report, as long as you send us the final report by the time it is due.~~

~~(2)~~ If you or we determine by September 30 ~~within 270 days~~ after the end of the model year that errors mistakenly decreased your balance of emission credits, you may correct the errors and recalculate the balance of emission credits. You may not make these corrections for errors that are determined later than September 30 ~~more than 270 days~~ after the end of the model year. If you report a negative balance of emission credits, we may disallow corrections under this paragraph (f)(~~2~~1).

~~(3)~~ If you or we determine any time that errors mistakenly increased your balance of emission credits, you must correct the errors and recalculate the balance of emission credits.

124. Amend §1037.735 by revising paragraph (b) to read as follows:

§ 1037.735 Recordkeeping.

* * * * *

(b) Keep the records required by this section for at least eight years after the due date for the ~~end-of-year~~ final report. You may not use emission credits for any vehicles if you do not keep all the records required under this section. You must therefore keep these records to continue to bank valid credits.

* * * * *

125. Amend §1037.740 by revising paragraph (b) to read as follows:

§ 1037.740 Restrictions for using emission credits.

* * * * *

(b) *Credits from hybrid vehicles and other advanced technologies.* The following provisions apply for credits you generate under § 1037.615.

(1) Credits generated from Phase 1 vehicles may be used for any of the averaging sets identified in paragraph (a) of this section; you may also use those credits to demonstrate compliance with the CO₂ emission standards in 40 CFR 86.1819 and 40 CFR part 1036. Similarly, you may use Phase 1 advanced-technology credits generated under 40 CFR 86.1819-14(k)(7) or 40 CFR 1036.615 to demonstrate compliance with the CO₂ standards in this part. ~~Credits generated from Phase 2 vehicles are subject to all the averaging set restrictions that apply to other emission credits.~~ (1) The maximum amount of advanced-technology credits generated from Phase 1 vehicles that you may bring into each of the following service class groups is 60,000 Mg per model year:

(i) Spark-ignition HDEengines, ~~light heavy-duty compression-ignition engines~~ Light HDE, and Light HDV. This group comprises the averaging set listed in paragraphs (a)(1) of this section and the averaging set listed in 40 CFR 1036.740(a)(1) and (2).

(ii) Medium ~~HDE heavy-duty compression-ignition engines~~ and Medium HDV. This group comprises the averaging sets listed in paragraph (a)(2) of this section and 40 CFR 1036.740(a)(3).

(iii) ~~Heavy heavy-duty compression-ignition engines~~ **Heavy HDE** and Heavy HDV. This group comprises the averaging sets listed in paragraph (a)(3) of this section and 40 CFR 1036.740(a)(4).

~~(2iv) Paragraph This paragraph~~ (b)(1) ~~of this section~~ does not limit the advanced-technology credits that can be used within a service class group if they were generated in that same service class group.

(2) Credits generated from Phase 2 vehicles are subject to all the averaging-set restrictions that apply to other emission credits.

* * * * *

126. Amend §1037.801 by:

a: Adding definitions for “Charge-depleting”, and “Charge-sustaining” in alphabetical order.

b: Revising the definitions of “Designated Compliance Officer”.

c. Adding a definition for “Emission-related component” in alphabetical order.

d. Revising the definitions for “Low rolling resistance tire”, “Neutral coasting”, “Rechargeable Energy Storage System (RESS)”, and “Tire rolling resistance level (TRRL)”.

The additions and revisions read as follows:

§ 1037.801 Definitions.

* * * * *

Charge-depleting has the meaning given in 40 CFR 1066.1001.

Charge-sustaining has the meaning given in 40 CFR 1066.1001.

* * * * *

Designated Compliance Officer means one of the following:

(1) For compression-ignition engines, *Designated Compliance Officer* means Director, Diesel Engine Compliance Center, U.S. Environmental Protection Agency, 2000 Traverwood Drive, Ann Arbor, MI 48105; complianceinfo@epa.gov; www.epa.gov/ve-certificationotaq/verify.

(2) For spark-ignition engines, *Designated Compliance Officer* means Director, Gasoline Engine Compliance Center, U.S. Environmental Protection Agency, 2000 Traverwood Drive, Ann Arbor, MI 48105; ~~nonroad-si-cert~~complianceinfo@epa.gov; www.epa.gov/ve-certification.

* * * * *

Emission-related component has the meaning given in 40 CFR part 1068, appendix A.

* * * * *

Low rolling resistance tire means a tire on a vocational vehicle with a TRRL at or below of 7.7 ~~kg/tonne~~[N/kN](#), a steer tire on a tractor with a TRRL at or below 7.7 ~~kg/tonne~~[N/kN](#), a drive tire on a tractor with a TRRL at or below 8.1 ~~kg/tonne~~[N/kN](#), a tire on a non-box trailer with a TRRL at or below of 6.5 ~~kg/tonne~~[N/kN](#), or a tire on a box van with a TRRL at or below of 6.0 ~~kg/tonne~~[N/kN](#).

* * * * *

Neutral coasting means a vehicle technology that automatically puts the transmission in neutral when the vehicle has minimal power demand while in motion, such as driving downhill.

* * * * *

Rechargeable Energy Storage System (RESS) has the meaning given in 40 CFR 1065.1001~~means the component(s) of a hybrid engine or vehicle that store recovered energy for later use, such as~~

~~the battery system in an electric hybrid vehicle.~~

* * * * *

Tire rolling resistance level (TRRL) means a value with units of ~~kg/tonne~~**N/kN** that represents the rolling resistance of a tire configuration. TRRLs are used as modeling inputs under §§ 1037.515 and 1037.520. Note that a manufacturer may use the measured value for a tire configuration's coefficient of rolling resistance, or assign some higher value.

* * * * *

127. Amend §1037.805 by revising paragraphs (a), (b), (d), (e), and (g) to read as follows:

§ 1037.805 Symbols, abbreviations, and acronyms.

* * * * *

(a) *Symbols for chemical species.* This part uses the following symbols for chemical species and exhaust constituents:

Table 1 to §1037.805—Symbols for Chemical Species and Exhaust Constituents

Symbol	Species
C	carbon.
CH ₄	methane.
CO	carbon monoxide.
CO ₂	carbon dioxide.
H ₂ O	water.
HC	hydrocarbon.
NMHC	nonmethane hydrocarbon.
NMHCE	nonmethane hydrocarbon equivalent.
NO	nitric oxide.
NO ₂	nitrogen dioxide.
NO _x	oxides of nitrogen.
N ₂ O	nitrous oxide.
PM	particulate matter.
THC	total hydrocarbon.
THCE	total hydrocarbon equivalent.

(b) *Symbols for quantities.* This part 1037 uses the following symbols and units of measure for various quantities:

Table 2 to §1037.805—Symbols for Quantities

SYMBOL	QUANTITY	UNIT	UNIT SYMBOL	UNIT IN TERMS OF SI BASE UNITS
A	vehicle frictional load	pound force or newton	lbf or N	kg·m·s ⁻² .
<i>a</i>	axle position regression coefficient			
	atomic hydrogen-to-carbon ratio	mole per mole	mol/mol	1.
	axle position regression coefficient			

	intercept of air speed correction			
	slope of air speed correction			
a_g	acceleration of Earth's gravity	meters per second squared	m/s^2	$m \cdot s^{-2}$.
a_0	intercept of least squares regression			
a_1	slope of least squares regression			
B	vehicle load from drag and rolling resistance	pound force per mile per hour or newton second per meter	lbf/(mi/hr) or N·s/m	$kg \cdot s^{-1}$.
b	axle position regression coefficient			
	atomic oxygen-to-carbon ratio	mole per mole	mol/mol	1.
	axle position regression coefficient			
	intercept of air direction correction			
	slope of air direction correction			
<u>B_{eff}</u>	<u>estimated battery efficiency</u>			
C	vehicle-specific aerodynamic effects	pound force per mile per hour squared or newton-second squared per meter squared	lbf/mph ² or N·s ² /m ²	$kg \cdot m^{-1}$.
<u>C</u>	<u>current of one ampere flowing for one hour</u>	<u>ampere per hour</u>	<u>kA·hr</u>	<u>3.6 kA·s.</u>
c	axle position regression coefficient			
c_i	axle test regression coefficients			
C_i	constant			
ΔC_{dA}	differential drag area	meter squared	m^2	m^2 .
C_{dA}	drag area	meter squared	m^2	m^2 .
C_d	drag coefficient			
CF	correction factor			
<u>CF</u>	<u>conversion factor</u>			
<u>CR</u>	<u>charge recovery</u>			
C_{rr}	coefficient of rolling resistance	kilogram per metric ton newton per kilonewton	kg/tonne <u>N/kN</u>	10^{-3} .

<i>D</i>	distance	miles or meters	mi or m	m.
<i>E</i>	<u>energy</u>	<u>kilowatt-hour</u>	<u>kW·hr</u>	<u>$3.6\cdot\text{m}^2\cdot\text{kg}\cdot\text{s}^{-1}$</u> .
<i>e</i>	mass-weighted emission result	grams/ <u>per</u> ton-mile	g/ton-mi	g/kg-km.
<i>EC</i>	<u>energy consumption</u>	<u>kilowatt-hour per mile</u>	<u>kW·hr/mi</u>	<u>$3.6\cdot\text{m}^2\cdot\text{kg}\cdot\text{s}^{-1}\cdot\text{mi}^{-1}$</u> .
<i>Eff</i>	efficiency			
<i>F</i>	adjustment factor			
<i>F</i>	force	pound force or newton	lbf or N	$\text{kg}\cdot\text{m}\cdot\text{s}^{-2}$.
<i>f_n</i>	angular speed (shaft)	revolutions per minute	r/min	$\pi\cdot 30\cdot\text{s}^{-1}$.
<i>G</i>	road grade	percent	%	10^{-2} .
<i>g</i>	gravitational acceleration	meters per second squared	m/s^2	$\text{m}\cdot\text{s}^{-2}$.
<i>h</i>	elevation or height	meters	m	m.
<i>I</i>	<u>current</u>	<u>ampere</u>	<u>A</u>	<u>A.</u>
<i>i</i>	indexing variable			
<i>k_a</i>	drive axle ratio			1.
<i>k_d</i>	transmission gear ratio			
<i>k_{topgear}</i>	highest available transmission gear			
<i>L</i>	load over axle	pound force or newton	lbf or N	$\text{kg}\cdot\text{m}\cdot\text{s}^{-2}$.
<i>m</i>	mass	pound mass or kilogram	lbm or kg	kg.
<i>M</i>	molar mass	gram per mole	g/mol	$10^{-3}\cdot\text{kg}\cdot\text{mol}^{-1}$.
<i>M</i>	<u>total number in series</u>			
<i>M</i>	vehicle mass	kilogram	kg	kg.
<i>M_e</i>	vehicle effective mass	kilogram	kg	kg.
<i>M_{rotating}</i>	inertial mass of rotating components	kilogram	kg	kg.
<i>N</i>	total number in series			
<i>n</i>	number of tires			
<i>n^{-ti}</i>	amount of substance rate	mole per second	mol/s	$\text{mol}\cdot\text{s}^{-1}$.
<i>Q</i>	<u>total number in series</u>			
<i>P</i>	power	kilowatt	kW	$10^3\cdot\text{m}^2\cdot\text{kg}\cdot\text{s}^{-3}$.
<i>p</i>	pressure	pascal	Pa	$\text{kg}\cdot\text{m}^{-1}\cdot\text{s}^{-2}$.
<i>ρ</i>	mass density	kilogram per cubic meter	kg/m^3	$\text{kg}\cdot\text{m}^{-3}$.
<i>PL</i>	payload	tons	ton	kg.
<i>φ</i>	direction	degrees	°	°.
<i>ψ</i>	direction	degrees	°	°.

<u>R</u>	<u>range</u>	<u>miles or meters</u>	<u>mi or m</u>	<u>m.</u>
<i>r</i>	tire radius	meter	m	m.
<i>r</i> ²	coefficient of determination			
<i>Re</i> [#]	Reynolds number			
<i>SEE</i>	standard error of the estimate			
σ	standard deviation			
<i>TRPM</i>	tire revolutions per mile	revolutions per mile	r/mi	
<i>TRRL</i>	tire rolling resistance level	kilogram <u>newton</u> per metrie ton <u>kilonewton</u>	kg/tonne <u>N/k</u> <u>N</u>	10 ⁻³ .
<i>T</i>	absolute temperature	kelvin	K	K.
<i>T</i>	Celsius temperature	degree Celsius	°C	K - 273.15.
<i>T</i>	torque (moment of force)	newton meter	N·m	m ² ·kg·s ⁻² .
<i>t</i>	time	hour or second	hr or s	s.
Δt	time interval, period, 1/frequency	second	s	s.
<u>UBE</u>	<u>useable battery energy</u>	<u>watt-hour</u>	<u>W·hr</u>	<u>3600·m²·kg·s⁻¹.</u>
<i>UF</i>	utility factor			
<u>V</u>	<u>voltage</u>	<u>volts</u>	<u>V</u>	<u>kg·m²·s⁻³·A⁻¹.</u>
<i>v</i>	speed	miles per hour or meters per second	mi/hr or m/s	m·s ⁻¹ .
<i>w</i>	weighting factor			
<i>w</i>	wind speed	miles per hour	mi/hr	m·s ⁻¹ .
<i>W</i>	work	kilowatt-hour	kW·hr	3.6·m ² ·kg·s ⁻¹ .
<i>wC</i>	carbon mass fraction	Gram per /gram	g/g	1.
<i>WR</i>	weight reduction	pound mass	lbm	kg.
<i>x</i>	amount of substance mole fraction	mole per mole	mol/mol	1.

* * * * *

(d) *Subscripts*. This part uses the following subscripts for modifying quantity symbols:
Table 4 to §1037.805—Subscripts

SUBSCRIPT	MEANING
±6	±6° yaw angle sweep.
A	A speed.
<u>AC</u>	<u>alternating current.</u>
<u>ACRC</u>	<u>alternating current recharge.</u>
air	air.
aero	aerodynamic.
alt	alternative.
act	actual or measured condition.
air	air.

axle	axle.
B	B speed.
<u>BEV</u>	<u>battery electric vehicle.</u>
brake	brake.
C	C speed.
Ccombdry	carbon from fuel per mole of dry exhaust.
CD	charge-depleting.
circuit	circuit.
CO2DEF	CO ₂ resulting from diesel exhaust fluid decomposition.
CO2PTO	CO ₂ emissions for PTO cycle.
coastdown	coastdown.
comp	composite.
CS	charge-sustaining.
<u>CSC</u>	<u>constant-speed cycle.</u>
<u>CSCM</u>	<u>constant-speed cycle midpoint.</u>
cycle	test cycle.
<u>D</u>	<u>distance.</u>
<u>DC</u>	<u>direct current.</u>
<u>DCD</u>	<u>direct current discharge.</u>
<u>DCRC</u>	<u>direct current recharge.</u>
drive	drive axle.
drive-idle	idle with the transmission in drive.
driver	driver.
dyno	dynamometer.
<u>E</u>	<u>end-of-test.</u>
effective	effective.
end	end.
eng	engine.
<u>factor</u>	<u>factor.</u>
<u>FCEV</u>	<u>fuel cell electric vehicle.</u>
<u>est</u>	<u>estimate.</u>
event	event.
<u>FTP</u>	<u>Federal Test Procedure.</u>
fuel	fuel.
full	full.
grade	grade.
H2Oexhaustdry	H ₂ O in exhaust per mole of exhaust.
<u>HDTC</u>	<u>Heavy-Duty Transient Cycle.</u>
hi	high.
i	an individual of a series.
idle	idle.
in	inlet.
inc	increment.

j	<u>an individual of a series.</u>
k	<u>an individual of a series.</u>
LLC	<u>Low Load Cycle.</u>
lo	low.
loss	loss.
M	<u>midpoint.</u>
max	maximum.
meas	measured quantity.
med	median.
min	minimum.
moving	moving.
out	outlet.
P	power.
pair	pair of speed segments.
parked-idle	idle with the transmission in park.
partial	partial.
ploss	power loss.
plug-in	plug-in hybrid electric vehicle.
powertrain	powertrain.
PTO	power take-off.
R	<u>range.</u>
rated	rated speed.
RC	<u>recharge.</u>
record	record.
ref	reference quantity.
RL	road load.
rotating	rotating.
seg	segment.
SET	<u>Supplemental Emission Test.</u>
speed	speed.
spin	axle spin loss.
start	start.
steer	steer axle.
t	tire.
test	test.
th	theoretical.
total	total.
trac	traction.
trac10	traction force at 10 mi/hr.
trailer	trailer axle.
transient	transient.
TRR	tire rolling resistance.
UF	<u>utility factor.</u>
urea	urea.
veh	vehicle.
w	wind.

wa	wind average.
yaw	yaw angle.
ys	yaw sweep.
zero	zero quantity.

(e) *Other acronyms and abbreviations.* This part uses the following additional abbreviations and acronyms:

Table 5 to §1037.805—Other Acronyms and Abbreviations

ACRONYM	MEANING
ABT	averaging, banking, and trading.
<u>AC</u>	<u>alternating current.</u>
AECD	auxiliary emission control device.
AES	automatic engine shutdown.
APU	auxiliary power unit.
CD	charge-depleting.
CFD	computational fluid dynamics.
CFR	Code of Federal Regulations.
CITT	curb idle transmission torque.
CS	charge-sustaining.
<u>CSC</u>	<u>constant-speed cycle.</u>
<u>DC</u>	<u>direct current.</u>
DOT	Department of Transportation.
ECM	electronic control module.
EPA	Environmental Protection Agency.
<u>FCC</u>	<u>fuel cell current.</u>
<u>FCV</u>	<u>fuel cell voltage.</u>
FE	fuel economy.
FEL	Family Emission Limit.
<u>FTP</u>	<u>Federal Test Procedure.</u>
GAWR	gross axle weight rating.
GCWR	gross combination weight rating.
GEM	greenhouse gas emission model.
GVWR	gross vehicle weight rating.
<u>HDTC</u>	<u>Heavy-Duty Transient Cycle.</u>
<u>Heavy HDE</u>	<u>heavy heavy-duty engine (see 40 CFR 1036.140).</u>
Heavy HDV	<u>h</u> Heavy heavy-duty vehicle (see § 1037.140).
HVAC	heating, ventilating, and air conditioning.
ISO	International Organization for Standardization.
<u>Light HDE</u>	<u>light heavy-duty engine (see 40 CFR 1036.140).</u>
Light HDV	<u>l</u> Light heavy-duty vehicle (see § 1037.140).
<u>LLC</u>	<u>Low Load Cycle.</u>
<u>MCT</u>	<u>Multicycle Test.</u>
<u>Medium HDE</u>	<u>medium heavy-duty engine (see 40 CFR 1036.140).</u>
Medium HDV	<u>m</u> Medium heavy-duty vehicle (see § 1037.140).
NARA	National Archives and Records Administration.
NHTSA	National Highway Transportation Safety Administration.
PHEV	plug-in hybrid electric vehicle.

PTO	power take-off.
RESS	rechargeable energy storage system.
SAE	SAE International Society of Automotive Engineers .
SCT	single cycle test .
SEE	standard error of the estimate.
SET	Supplemental Emission Test .
SKU	stock-keeping unit.
Spark-ignition HDE	spark-ignition heavy-duty engine (see 40 CFR 1036.140) .
TRPM	tire revolutions per mile.
TRRL	tire rolling resistance level.
UBE	useable battery energy .
U.S.C.	United States Code.
VSL	vehicle speed limiter.

* * * * *

(g) *Prefixes*. This part uses the following prefixes to define a quantity:

Table 7 to §1037.805—Prefixes

Symbol	Quantity	Value
μ	micro	10 ⁻⁶
m	milli	10 ⁻³
c	centi	10 ⁻²
k	kilo	10 ³
M	mega	10 ⁶

128. Amend §1037.810 by revising paragraphs (a) and (e) and adding paragraph (f) to read as follows:

§ 1037.810 Incorporation by reference.

(a) Certain material is incorporated by reference into this part with the approval of the Director of the Federal Register under 5 U.S.C. 552(a) and 1 CFR part 51. To enforce any edition other than that specified in this section, the Environmental Protection Agency must publish a document in the Federal Register and the material must be available to the public. All approved material is available for inspection at EPA Docket Center, WJC West Building, Room 3334, 1301 Constitution Avenue, N.W., Washington, DC 20004, www.epa.gov/dockets, (202) 202-1744, and is available from the sources listed in this section. It is also available for inspection at the National Archives and Records Administration (NARA). For information on the availability of this material at NARA, email fedreg.legalfr.inspection@nara.gov, call 202-741-6030, or go to www.archives.gov/federal-register/cfr/ibr-locations.html

* * * * *

(e) SAE International, 400 Commonwealth Dr., Warrendale, PA 15096-0001, (877) 606-7323 (U.S. and Canada) or (724) 776-4970 (outside the U.S. and Canada), <http://www.sae.org>.

- (1) SAE J1025, Test Procedures for Measuring Truck Tire Revolutions Per Kilometer/Mile, Stabilized August 2012, (“SAE J1025”), IBR approved for § 1037.520(c).
- (2) SAE J1252, SAE Wind Tunnel Test Procedure for Trucks and Buses, Revised July 2012, (“SAE J1252”), IBR approved for §§ 1037.525(b) and 1037.530(a).
- (3) SAE J1263, Road Load Measurement and Dynamometer Simulation Using Coastdown Techniques, revised March 2010, (“SAE J1263”), IBR approved for §§ 1037.528 introductory text, (a), (b), (c), (e), and (h) and 1037.665(a).

(4) SAE J1594, Vehicle Aerodynamics Terminology, Revised July 2010, (“SAE J1594”), IBR approved for § 1037.530(d).

(5) SAE J2071, Aerodynamic Testing of Road Vehicles - Open Throat Wind Tunnel Adjustment, Revised June 1994, (“SAE J2071”), IBR approved for § 1037.530(b).

(6) SAE J2263, Road Load Measurement Using Onboard Anemometry and Coastdown Techniques, Revised ~~May 2020~~December 2008, (“SAE J2263”), IBR approved for §§ 1037.528 introductory text, (a), (b), (d), and (f) and 1037.665(a).

(7) SAE J2343, Recommended Practice for LNG Medium and Heavy-Duty Powered Vehicles, Revised July 2008, (“SAE J2343”), IBR approved for § 1037.103(e).

(8) SAE J2452, Stepwise Coastdown Methodology for Measuring Tire Rolling Resistance, Revised June 1999, (“SAE J2452”), IBR approved for § 1037.528(h).

(9) SAE J2841, Utility Factor Definitions for Plug-In Hybrid Electric Vehicles Using 2001 U.S. DOT National Household Travel Survey Data, Issued March 2009, (“SAE J2841”), IBR approved for § 1037.550(a).

(10) SAE J2966, Guidelines for Aerodynamic Assessment of Medium and Heavy Commercial Ground Vehicles Using Computational Fluid Dynamics, Issued September 2013, (“SAE J2966”), IBR approved for § 1037.532(a).

(f) Idaho National Laboratory, 2525 Fremont Ave., Idaho Falls, ID 83415-3805, (866) 495-7440, or www.inl.gov.

(1) United States Advanced Battery Consortium, Electric Vehicle Battery Test Procedures Manual, Revision 2, January 1996, IBR approved for § 1037.552(a).

(2) [Reserved]

129. Revise §1037.815 to read as follows:

§ 1037.815 Confidential information.

The provisions of 40 CFR 1068.10 and 1068.11 apply for information you submit under this part~~consider confidential~~.

- Appendix I to part 1037—[Redesignated as appendix A to part 1037]**
- Appendix II to part 1037—[Redesignated as appendix B to part 1037]**
- Appendix III to part 1037 [Redesignated as appendix C to part 1037]**
- Appendix IV to part 1037—[Redesignated as appendix D to part 1037]**
- Appendix V to part 1037—[Redesignated as appendix E to part 1037]**

130. Redesignate appendices to part 1037 as follows:

old appendix	new appendix
appendix I to part 1037	appendix A to part 1037
appendix II to part 1037	appendix B to part 1037
appendix III to part 1037	appendix C to part 1037
appendix IV to part 1037	appendix D to part 1037
appendix V to part 1037	appendix E to part 1037

PART 1039—CONTROL OF EMISSIONS FROM NEW AND IN-USE NONROAD COMPRESSION-IGNITION ENGINES

131. The authority citation for part 1039 continues to read as follows:
Authority: 42 U.S.C. 7401-7671q.

132. Amend §1039.105 by revising the section heading and paragraphs (a) introductory text and (b) introductory text to read as follows:

§ 1039.105 What smoke opacity standards must my engines meet?

(a) The smoke opacity standards in this section apply to all engines subject to emission standards under this part, except for the following engines:

* * * * *

(b) Measure smoke opacity as specified in § 1039.501(c). Smoke opacity from your engines may not exceed the following standards:

* * * * *

133. Amend § 1039.115 by revising paragraphs (e) and (f) to read as follows:

§ 1039.115 What other requirements apply?

* * * * *

(e) *Adjustable parameters.* Engines that have adjustable parameters must meet all the requirements of this part for any adjustment in the physically adjustable range. ~~An operating parameter is not considered adjustable if you permanently seal it or if it is not normally accessible using ordinary tools.~~ We may require that you set adjustable parameters to any specification within the adjustable range during any testing, including certification testing, selective enforcement auditing, or in-use testing. General provisions for adjustable parameters apply as specified in 40 CFR 1068.50.

(f) *Prohibited controls.* (1) General provisions. You may not design your engines with emission control devices, systems, or elements of design that cause or contribute to an unreasonable risk to public health, welfare, or safety while operating. For example, ~~this would apply if the an engine may not~~ emits a noxious or toxic substance it would otherwise not emit that contributes to such an unreasonable risk.

(2) Vanadium sublimation in SCR catalysts. For engines equipped with vanadium-based SCR catalysts, you must design the engine and its emission controls to prevent vanadium sublimation and protect the catalyst from high temperatures. We will evaluate your engine design based on the following information that you must include in your application for certification:

(i) Identify the threshold temperature for vanadium sublimation for your specified SCR catalyst formulation as described in 40 CFR 1065.1113 through 1065.1121.

(ii) Describe how you designed your engine to prevent catalyst inlet temperatures from exceeding the temperature you identify in paragraph (g)(1) of this section, including consideration of engine wear through the useful life. Also describe your design for catalyst protection in case catalyst temperatures exceed the specified temperature. In your description, include how you considered elevated catalyst temperature resulting from sustained high-load engine operation, catalyst exotherms, DPF regeneration, and component failure resulting in unburned fuel in the exhaust stream.

* * * * *

134. Amend § 1039.205 by revising paragraph (s) to read as follows:

§ 1039.205 What must I include in my application?

* * * * *

(s) Describe all adjustable operating parameters (see § 1039.115(e)), including production tolerances. For any operating parameters that do not qualify as adjustable parameters, include a description supporting your conclusion (see 40 CFR 1068.50(c)). Include the following in your description of each adjustable parameter:

(1) For mechanically controlled parameters, include ~~T~~the nominal or recommended setting,
~~(2) T~~the intended physically adjustable range, and (3) Tthe limits or stops used to establish
limit adjustable ranges, and production tolerances of the limits or stops used to establish each
physically adjustable range. (4) Also include ~~I~~information showing why the limits, stops, or
other means of inhibiting adjustment are effective in preventing adjustment of parameters on
in-use engines to settings outside your intended physically adjustable ranges.

(2) For electronically controlled parameters, describe how your engines are designed to
prevent unauthorized adjustments.

* * * * *

135. Amend § 1039.245 by adding paragraph (e) to read as follows:

§ 1039.245 How do I determine deterioration factors from exhaust durability testing?

* * * * *

(e) You may alternatively determine and verify deterioration factors based on bench-aged
aftertreatment as described in 40 CFR 1036.245 and 1036.246, with the following exceptions:

(1) Apply the percentage of useful life from Table 1 of 40 CFR 1036.246 based on hours of
operation rather than vehicle mileage.

(2) Use good engineering judgment to perform verification testing using the procedures of
§ 1039.515 rather than 40 CFR 1036.520. Measure emissions as the equipment goes through
its normal operation over the course of the day (or shift-day).

(3) Apply infrequent regeneration adjustment factors as specified in § 1039.525 rather than
40 CFR 1036.522.

136. Amend § 1039.501 by revising paragraph (c) to read as follows:

§ 1039.501 How do I run a valid emission test?

* * * * *

(c) Measure smoke opacity using the procedures in 40 CFR part 1065, subpart I~~86, subpart I~~, for
evaluating whether engines meet the smoke opacity standards in § 1039.105, except that you
may test two-cylinder engines with an exhaust muffler like those installed on in-use engines.

* * * * *

137. Revise § 1039.655 to read as follows:

**§ 1039.655 What special provisions apply to engines sold in ~~Guam, American Samoa, or~~
the Commonwealth of the Northern Mariana Islands?**

(a) The prohibitions in §1068.101(a)(1) do not apply to ~~an~~engines at or above 56 kW if the
following conditions are met:

(1) The engine is intended for use and will be used in ~~Guam, American Samoa, or the~~
Commonwealth of the Northern Mariana Islands.

(2) The engine meets the latest applicable emission standards in appendix I of this part.

(3) You meet all the requirements of 40 CFR 1068.265.

(b) If you introduce an engine into commerce in the United States under this section, you must meet the labeling requirements in § 1039.135, but add the following statement instead of the compliance statement in § 1039.135(c)(12):

THIS ENGINE DOES NOT COMPLY WITH U.S. EPA TIER 4 EMISSION REQUIREMENTS. IMPORTING THIS ENGINE INTO THE UNITED STATES OR ANY TERRITORY OF THE UNITED STATES EXCEPT ~~GUAM,~~ AMERICAN SAMOA, OR THE COMMONWEALTH OF THE NORTHERN MARIANA ISLANDS MAY BE A VIOLATION OF FEDERAL LAW SUBJECT TO CIVIL PENALTY.

(c) Introducing into commerce an engine exempted under this section in any state or territory of the United States other than ~~Guam,~~ American Samoa, or the Commonwealth of the Northern Mariana Islands, throughout its lifetime, violates the prohibitions in 40 CFR 1068.101(a)(1), unless it is exempt under a different provision.

(d) The exemption provisions in this section also applied for engines that were introduced into commerce in Guam before [INSERT DATE 30 DAYS AFTER DATE OF PUBLICATION IN THE FEDERAL REGISTER] if they would otherwise have been subject to Tier 4 standards.

138. Amend § 1039.801 by revising the definitions of “Critical emission-related component” and “Designated Compliance Officer” to read as follows:

§ 1039.801 What definitions apply to this part?

* * * * *

Critical emission-related component has the meaning given in 40 CFR 1068.30.~~means any of the following components:~~

~~(1) Electronic control units, aftertreatment devices, fuel metering components, EGR system components, crankcase ventilation valves, all components related to charge air compression and cooling, and all sensors and actuators associated with any of these components.~~

~~(2) Any other component whose primary purpose is to reduce emissions.~~

* * * * *

Designated Compliance Officer means the Director, Diesel Engine Compliance Center, U.S. Environmental Protection Agency, 2000 Traverwood Drive, Ann Arbor, MI 48105; complianceinfo@epa.gov; www.epa.gov/ve-certificationotaq/verify.

* * * * *

PART 1042—CONTROL OF EMISSIONS FROM NEW AND IN-USE MARINE COMPRESSION-IGNITION ENGINES AND VESSELS

139. The authority citation for part 1042 continues to read as follows:
Authority: 42 U.S.C. 7401-7671q.

140. Amend §1042.110 by revising paragraph (a)(1) introductory text to read as follows:

§ 1042.110 Recording reductant use and other diagnostic functions.

(a) * * *

(1) The diagnostic system must monitor reductant ~~supply quality and tank levels~~ and alert operators to the need to ~~refill the reductant tank before it is empty~~, or to replace the reductant if it does not meet your concentration specifications. Unless we approve other alerts, use a ~~malfunction indicator light (MIL)~~ and an audible alarm. You do not need to separately monitor reductant quality if your system uses input from an exhaust NO_x sensor (or other sensor) to alert operators when reductant quality is inadequate. However, tank level ~~or DEF flow~~ must be monitored in all cases.

* * * * *

141. Amend § 1042.115 by revising paragraphs (d) introductory text and (e) to read as follows:

§ 1042.115 Other requirements.

* * * * *

(d) *Adjustable parameters.* ~~An operating parameter is not considered adjustable if you permanently seal it or if it is not normally accessible using ordinary tools.~~ General provisions for adjustable parameters apply as specified in 40 CFR 1068.50. The following additional category-specific provisions apply ~~for adjustable parameters~~:

* * * * *

(e) *Prohibited controls.* (1) General provisions. You may not design your engines with emission-control devices, systems, or elements of design that cause or contribute to an unreasonable risk to public health, welfare, or safety while operating. For example, ~~this would apply if the an engine may not emits~~ a noxious or toxic substance it would otherwise not emit; that contributes to such an unreasonable risk.

(2) Vanadium sublimation in SCR catalysts. For engines equipped with vanadium-based SCR catalysts, you must design the engine and its emission controls to prevent vanadium sublimation and protect the catalyst from high temperatures. We will evaluate your engine design based on the following information that you must include in your application for certification:

(i) Identify the threshold temperature for vanadium sublimation for your specified SCR catalyst formulation as described in 40 CFR 1065.1113 through 1065.1121.

(ii) Describe how you designed your engine to prevent catalyst inlet temperatures from exceeding the temperature you identify in paragraph (g)(1) of this section, including consideration of engine wear through the useful life. Also describe your design for catalyst protection in case catalyst temperatures exceed the specified temperature. In your description, include how you considered elevated catalyst temperature resulting from sustained high-load engine operation, catalyst exotherms, DPF regeneration, and component failure resulting in unburned fuel in the exhaust stream.

* * * * *

142. Amend § 1042.145 by adding paragraph (h) to read as follows:

§ 1042.145 Interim provisions.

* * * * *

(h) Expanded production-line testing. Production-line testing requirements for Category 1 engine families with a projected U.S.-directed production volume below 100 engines and for all families certified by small-volume engine manufacturers start to apply in model year 2024. All manufacturers must test no more than four engine families in a single model year, and small-volume engine manufacturers must test no more than two engine families in a single model year.

* * * * *

143. Amend § 1042.205 by revising paragraphs (c) and (s) to read as follows:

§ 1042.205 Application requirements.

* * * * *

(c) If your engines are equipped with an engine diagnostic system as required under § 1042.110, explain how it works, describing especially the engine conditions (with the corresponding diagnostic trouble codes) that cause the warning lamp malfunction-indicator light to go on. Also identify the communication protocol (SAE J1939, SAE J1979, etc.).

* * * * *

(s) Describe all adjustable operating parameters (see § 1042.115(d)), including production tolerances. For any operating parameters that do not qualify as adjustable parameters, include a description supporting your conclusion (see 40 CFR 1068.50(c)). Include the following in your description of each adjustable parameter:

(1) For mechanically controlled parameters, include ~~T~~the nominal or recommended setting, ~~(2) T~~the intended physically adjustable range, and ~~(3) T~~the limits or stops used to establish adjustable ranges.

~~(i4)~~ For Category 1 engines, include information showing why the limits, stops, or other means of inhibiting mechanical adjustment are effective in preventing adjustment of parameters on in-use engines to settings outside your intended physically adjustable ranges.

~~(ii5)~~ For Category 2 and Category 3 engines, propose a range of mechanical adjustment for each adjustable parameter, as described in § 1042.115(d). Include information showing why the limits, stops, or other means of inhibiting mechanical adjustment are effective in preventing adjustment of parameters on in-use engines to settings outside your proposed adjustable ranges.

(2) For electronically controlled parameters, describe how your engines are designed to prevent unauthorized adjustments.

* * * * *

144. Amend § 1042.245 by adding paragraph (e) to read as follows:

§ 1042.245 Deterioration factors.

* * * * *

(e) You may alternatively determine and verify deterioration factors based on bench-aged aftertreatment as described in 40 CFR 1036.245 and 1036.246, with the following exceptions:

(1) Apply the percentage of useful life from Table 1 of 40 CFR 1036.246 based on hours of operation rather than vehicle mileage.

- (2) Use good engineering judgment to perform verification testing using the procedures of § 1042.515 rather than 40 CFR 1036.520. Measure emissions as the vessel goes through its normal operation over the course of the day (or shift-day).
- (3) Apply infrequent regeneration adjustment factors as specified in § 1042.525 rather than 40 CFR 1036.522.

145. Revise § 1042.301 to read as follows:

§ 1042.301 General provisions.

(a) If you produce freshly manufactured marine engines that are subject to the requirements of this part, you must test them as described in this subpart, ~~except as follows:~~

~~(1) Small volume engine manufacturers may omit testing under this subpart.~~

~~(2) We may exempt Category 1 engine families with a projected U.S. directed production volume below 100 engines from routine testing under this subpart. Request this exemption in your application for certification and include your basis for projecting a production volume below 100 units. We will approve your request if we agree that you have made good faith estimates of your production volumes. Your exemption is approved when we grant your certificate. You must promptly notify us if your actual production exceeds 100 units during the model year. If you exceed the production limit or if there is evidence of a nonconformity, we may require you to test production line engines under this subpart, or under 40 CFR part 1068, subpart E, even if we have approved an exemption under this paragraph (a)(2).~~

~~(3) [Reserved]~~

(b) We may suspend or revoke your certificate of conformity for certain engine families if your production-line engines do not meet the requirements of this part or you do not fulfill your obligations under this subpart (see §§ 1042.325 and 1042.340). Similarly, we may deny applications for certification for the upcoming model year if you do not fulfill your obligations under this subpart (see § 1042.255(c)(1)).

(c) Other regulatory provisions authorize us to suspend, revoke, or void your certificate of conformity, or order recalls for engine families, without regard to whether they have passed ~~these~~ production-line testing requirements. The requirements of this subpart do not affect our ability to do selective enforcement audits, as described in 40 CFR part 1068. Individual engines in families that pass ~~these~~ production-line testing requirements must also conform to all applicable regulations of this part and 40 CFR part 1068.

~~(d) You may use alternate programs or measurement methods for testing production line engines in the following circumstances:~~

~~(1) [Reserved]~~

~~(2) You may test your engines using the CumSum procedures specified in 40 CFR part 1045 or 1051 instead of the procedures specified in this subpart, except that the threshold for establishing quarterly or annual test periods is based on U.S. directed production volumes of 800 instead of 1600. This alternate program does not require prior approval.~~

~~(3) You may ask to use another alternate program or measurement method for testing production-line engines. In your request, you must show us that the alternate program gives equal assurance that your engines meet the requirements of this part. We may waive some or all of this subpart's requirements if we approve your alternate program.~~

(e) If you certify a Category 1 or Category 2 engine family with carryover emission data, as described in § 1042.235(d), you may omit production-line testing if you fulfilled your testing requirements with a related engine family in an earlier year, except as follows:

(1) We may require that you perform additional production-line testing under this subpart in any model year for cause, such as if you file a defect report related to the engine family or if you amend your application for certification in any of the following ways:

(i) You designate a different supplier or change technical specifications for any critical emission-related components.

(ii) You add a new or modified engine configuration such that the test data from the original emission-data engine do not clearly continue to serve as worst-case testing for certification.

(iii) You change your family emission limit without submitting new emission data.

(2) If you certify an engine family with carryover emission data with no production-line testing for more than five model years, we may require that you perform production-line testing again for one of those later model years unless you demonstrate that none of the circumstances identified in paragraph (e)(1) of this section apply for the engine family.

~~and these equivalent engine families consistently pass the production line testing requirements over the preceding two year period, you may ask for a reduced testing rate for further production line testing for that family. The minimum testing rate is one engine per engine family. If we reduce your testing rate, we may limit our approval to any number of model years. In determining whether to approve your request, we may consider the number of engines that have failed the emission tests.~~

(f) We may ask you to make a reasonable number of production-line engines available for a reasonable time so we can test or inspect them for compliance with the requirements of this part. For Category 3 engines, you are not required to deliver engines to us, but we may inspect and test your engines at any facility at which they are assembled or installed in vessels.

146. Amend § 1042.302 by revising the introductory text to read as follows:

§ 1042.302 Applicability of this subpart for Category 3 engines.

If you produce Tier 3 or later Category 3 engines that are ~~certified under~~ subject to the requirements of this part, you must test them as described in this subpart, except as specified in this section.

* * * * *

147. Amend § 1042.305 by revising paragraph (a) to read as follows:

§ 1042.305 Preparing and testing production-line engines.

* * * * *

(a) Test procedures. Test your production-line engines using the applicable testing procedures in subpart F of this part to show you meet the duty-cycle emission standards in subpart B of this part. For Category 1 and Category 2 engines, the not-to-exceed standards apply for this testing of Category 1 and Category 2 engines, but you need not do additional testing to show that production-line engines meet the not-to-exceed standards. The mode cap standards apply for ~~the~~ testing ~~of~~ Category 3 engines subject to Tier 3 standards (or for engines subject to the Annex VI Tier III NOx standards under §1042.650(d)).

* * * * *

148. Revise § 1042.310 to read as follows:

§ 1042.310 Engine selection for Category 1 and Category 2 engines.

(a) ~~Determine minimum sample sizes as follows:~~

~~(1) For Category 1 and Category 2 engines families, the minimum sample size is one engine. You may ask us to approve treating commercial and recreational engines as being from the same engine family for purposes of production-line testing if you certify them using the same emission-data engine. or one percent of the projected U.S. directed production volume for all your Category 1 engine families, whichever is greater.~~

~~(2) For Category 2 engines, the minimum sample size is one engine or one percent of the projected U.S. directed production volume for all your Category 2 engine families, whichever is greater.~~

(b) Select engines for testing as follows:

~~(1) For Category 1 engines, Rrandomly select one engine within the first 60 days of the start of production for from each engine family early in the model year. For further testing to reach the minimum sample size, randomly select a proportional sample from each engine family, with testing distributed evenly over the course of the model year, unless we specify a different schedule for your tests. For example, we may require you to disproportionately select engines from the early part of a model year for a new engine model that has not previously been subject to production-line testing.~~

~~(2) For Category 2 engines, randomly select one engine within 60 days after you produce the fifth engine from an engine family (or from successive families that are related based on your use of carryover data under §1042.230(d)).~~

~~(3) If you do not produce an engine from the engine family in the specified time frame, test the next engine you produce.~~

~~(4) You may preferentially test engines earlier than we specify.~~

~~(5) You meet the requirement to randomly select engines under this section if you assemble the engine in a way that fully represents your normal production and quality procedures.~~

(c) For each engine that fails to meet emission standards, test two engines from the same engine family from the next fifteen engines produced or within seven days, whichever is later. If you do not produce fifteen additional engines within 90 days, test two additional engines within 90 days or as soon as practicable. If an engine fails to meet emission standards for any pollutant, count it as a failing engine under this paragraph (c).

(d) Continue testing until one of the following things happens:

(1) You test the number of engines specified in required under paragraphs (ba) and (c) of this section. For example, if the initial engine fails and then two engines pass, testing is complete for that engine family.

(2) The engine family does not comply according to § 1042.315 or you choose to declare that the engine family does not comply with the requirements of this subpart.

~~(3) You test 30 engines from the engine family.~~

(e) You may elect to test more randomly chosen engines than we require under this section.

149. Amend § 1042.315 by revising paragraphs (a)(1) and (b) to read as follows:

§ 1042.315 Determining compliance.

* * * * *

(a) * * *

(1) Initial and final test results. Calculate and round the test results for each engine. If you do ~~several~~ multiple tests on an engine in a given configuration (without modifying the engine), calculate the initial results for each test, then add all the test results together and divide by the number of tests. Round this final calculated value for the final test results on that engine. Include the Green Engine Factor to determine low-hour emission results, if applicable.

* * * * *

(b) For Category 1 and Category 2 engines, if a production-line engine fails to meet emission standards and you test ~~two~~ additional engines as described in § 1042.310, calculate the average emission level for each pollutant for all the ~~three~~ engines. If the calculated average emission level for any pollutant exceeds the applicable emission standard, the engine family fails the production-line testing requirements of this subpart. Tell us within ten working days if an engine fails~~this happens~~. You may request to amend the application for certification to raise the FEL of the engine family as described in § 1042.225(f).

150. Amend § 1042.320 by revising paragraph (c) to read as follows:

§ 1042.320 What happens if one of my production-line engines fails to meet emission standards?

* * * * *

(c) Use test data from a failing engine for the compliance demonstration under §1042.315 as follows:

(1) Use the original, failing test results as described in §1042.315, whether or not you modify the engine or destroy it. However, if For catalyst-equipped engines, you may ask us to allow you to exclude an initial failed test if all ~~of~~ the following are true:

- (i)~~1~~ The catalyst was in a green condition when tested initially.
- (ii)~~2~~ The engine met all emission standards when retested after degreening the catalyst.
- (iii)~~3~~ No additional emission-related maintenance or repair was performed between the initial failed test and the subsequent passing test.

(2) Do not use test results from a modified engine as final test results under §1042.315, unless you change your production process for all engines to match the adjustments you made to the failing engine. If you change production processes and use the test results from a modified engine, count the modified engine as the next engine in the sequence, rather than averaging the results with the testing that occurred before modifying the engine.

151. Amend § 1042.325 by revising paragraph (b) to read as follows:

§ 1042.325 What happens if an engine family fails the production-line testing requirements?

* * * * *

(b) We will tell you in writing if we suspend your certificate in whole or in part. We will not suspend a certificate until at least 15 days after the engine family fails as described in §1042.315(b). The suspension is effective when you receive our notice.

* * * * *

152. Revise § 1042.345 to read as follows:

§ 1042.345 Reporting.

(a) Send us a test report ~~W~~within 45 days ~~of the end of each quarter in which~~ after you complete production-line testing for a Category 1 or Category 2 engine family, and within 45 days after you finish testing each Category 3 engine. We may approve a later submission for Category 3 engines if it allows you to combine test reports for multiple engines. ~~occurs, send us a~~

(b) Include ~~report with~~ the following information in the report:

- (1) Describe any facility used to test production-line engines and state its location.
- ~~(2) State the total U.S. directed production volume and number of tests for each engine family.~~

~~(23)~~ For Category 1 and Category 2 engines. Describe how you randomly selected engines.

~~(34)~~ Describe each test engine, including the engine family's identification and the engine's model year, build date, model number, identification number, and number of hours of operation before testing. Also describe how you developed and applied the Green Engine Factor, if applicable.

~~(45)~~ Identify how you accumulated hours of operation on the engines and describe the procedure and schedule you used.

~~(56)~~ Provide the test number; the date, time and duration of testing; test procedure; all initial test results; final test results; and final deteriorated test results for all tests. Provide the emission results for all measured pollutants. Include information for both valid and invalid tests and the reason for any invalidation.

~~(67)~~ Describe completely and justify any nonroutine adjustment, modification, repair, preparation, maintenance, or test for the test engine if you did not report it separately under this subpart. Include the results of any emission measurements, regardless of the procedure or type of engine.

~~(8) Report on each failed engine as described in §1042.320.~~

~~(9) Identify when the model year ends for each engine family.~~

~~(c**b**)~~ We may ask you to add information to your written report so we can determine whether your new engines conform with the requirements of this subpart. We may also ask you to send less information.

~~(d**e**)~~ An authorized representative of your company must sign the following statement:
We submit this report under sections 208 and 213 of the Clean Air Act. Our production-line testing conformed completely with the requirements of 40 CFR part 1042. We have not changed production processes or quality-control procedures for test engines in a way that might affect emission controls. All the information in this report is true and accurate to the best of my knowledge. I know of the penalties for violating the Clean Air Act and the regulations.
(Authorized Company Representative)

~~(e**d**)~~ Send electronic reports of production-line testing to the Designated Compliance Officer using an approved information format. If you want to use a different format, send us a written request with justification for a waiver. You may combine reports from multiple engines and engine families into a single report.

~~(f**e**)~~ We will send copies of your reports to anyone from the public who asks for them. See § 1042.915 for information on how we treat information you consider confidential.

153. Amend § 1042.515 by revising paragraph (d) to read as follows:

§ 1042.515 Test procedures related to not-to-exceed standards.

* * * * *

(d) Engine testing may occur at any conditions expected during normal operation but that are outside the conditions described in paragraph ~~(c**b**)~~ of this section, as long as measured values are corrected to be equivalent to the nearest end of the specified range, using good engineering judgment. Correct NO_x emissions for humidity as specified in 40 CFR part 1065, subpart G.

* * * * *

154. Amend § 1042.615 by revising paragraph (g) introductory text to read as follows:

§ 1042.615 Replacement engine exemption.

* * * * *

(g) In unusual circumstances, you may ask us to allow you to apply the replacement engine exemption of this section for repowering a steamship or a vessel that becomes a “new vessel” under § 1042.901 as a result of modifications, as follows:

* * * * *

155. Amend § 1042.660 by revising paragraph (b) to read as follows:

§ 1042.660 Requirements for vessel manufacturers, owners, and operators.

* * * * *

(b) For vessels equipped with SCR systems requiring the use of urea or other reductants, owners and operators must report to the Designated Enforcement Compliance Officer within 30 days any operation of such vessels without the appropriate reductant. For each reportable incident, include the cause of the noncompliant operation, the remedy, and an estimate of the extent of operation without reductant. You must remedy the problem as soon as practicable to avoid violating the tampering prohibition in 40 CFR 1068.101(b)(1). If the remedy is not complete within 30 days of the incident, notify the Designated Compliance Officer when the issue is resolved, along with any relevant additional information related to the repair. This reporting requirement applies for all engines on covered vessels even if the engines are certified to Annex VI standards instead of or in addition to EPA standards under this part. This includes vessels with auxiliary engines certified to Annex VI standards under §1042.650(d). Failure to comply with the reporting requirements of this paragraph is a violation of 40 CFR 1068.101(a)(2). Note that ~~such operation operating such engines without reductant~~ is a violation of 40 CFR 1068.101(b)(1).

* * * * *

156. Amend § 1042.901 by revising the definitions of “Category 1”, “Category 2”, “Critical emission-related component”, and “Designated Compliance Officer” and removing the definition of “Designated Enforcement Officer” to read as follows:

§ 1042.901 Definitions.

* * * * *

Category 1 means relating to a marine engine with specific engine displacement below 7.0 liters per cylinder. See § 1042.670 to determine equivalent per-cylinder displacement for nonreciprocating marine engines (such as gas turbine engines). Note that the maximum specific engine displacement for Category 1 engines subject to Tier 1 and Tier 2 standards was 5.0 liters per cylinder.

Category 2 means relating to a marine engine with a specific engine displacement at or above 7.0 liters per cylinder but less than 30.0 liters per cylinder. See § 1042.670 to determine equivalent per-cylinder displacement for nonreciprocating marine engines (such as gas turbine engines). Note that the minimum specific engine displacement for Category 2 engines subject to Tier 1 and Tier 2 standards was 5.0 liters per cylinder.

* * * * *

Critical emission-related component has the meaning given in 40 CFR 1068.30. ~~means any of the following components:~~

- ~~(1) Electronic control units, aftertreatment devices, fuel metering components, EGR system components, crankcase ventilation valves, all components related to charge air compression and cooling, and all sensors and actuators associated with any of these components.~~
- ~~(2) Any other component whose primary purpose is to reduce emissions.~~

* * * * *

Designated Compliance Officer means the Director, Diesel Engine Compliance Center, U.S. Environmental Protection Agency, 2000 Traverwood Drive, Ann Arbor, MI 48105; complianceinfo@epa.gov; www.epa.gov/ve-certificationotaq/verify.

* * * * *

157. Amend appendix I to part 1042 by revising paragraph (a) to read as follows:

Appendix I to Part 1042—Summary of Previous Emission Standards

* * * * *

(a) *Engines below 37 kW.* Tier 1 and Tier 2 standards for engines below 37 kW originally adopted under 40 CFR part 89 apply as follows:

Table 1 to Appendix I—Emission Standards for Engines Below 37 kW (g/kW-hr)

Rated power (kW)	Tier	Model year	NMHC + NOx	CO	PM
kW<8	Tier 1	2000	10.5	8.0	1.0
	Tier 2	2005	7.5	8.0	0.80
8≤kW<19	Tier 1	2000	9.5	6.6	0.80
	Tier 2	2005	7.5	6.6	0.80
19≤kW<37	Tier 1	1999	9.5	5.5	0.80
	Tier 2	2004	7.5	5.5	0.60

* * * * *

PART 1043— CONTROL OF NOX, SOX, AND PM EMISSIONS FROM MARINE ENGINES AND VESSELS SUBJECT TO THE MARPOL PROTOCOL

158. The authority citation for part 1043 continues to read as follows:
Authority: 33 U.S.C. 1901-1912.

159. Amend §1043.20 by removing the definition of “Public vessels” and adding a definition of “Public vessel” in alphabetical order to read as follows:

§ 1043.20 Definitions.

* * * * *

Public vessels means a warships, naval auxiliary vessels, ~~and or~~ other vessels owned or operated by a sovereign country when engaged in noncommercial service. Vessels with a national security exemption under 40 CFR ~~80.606 or~~ 1042.635 are deemed to be public vessels with respect to compliance with NOx-related requirements of this part when engaged in noncommercial service. Similarly, vessels with one or more installed engines that have a national security exemption under 40 CFR 1090.605 are deemed to be public vessels with respect to compliance with fuel content requirements when engaged in noncommercial service.

* * * * *

160. Amend §1043.55 by revising paragraphs (a) and (b) to read as follows:

§ 1043.55 Applying equivalent controls instead of complying with fuel requirements.

* * * * *

(a) ~~The U.S. Coast Guard is the approving authority under APPS for such equivalent methods for U.S.-flagged vessels. Any person may request approval of such equivalent methods for controlling emissions on U.S.-flagged vessels by submitting an application for certification of an equivalent control method to the Designated Certification Officer. If we determine that your control method achieves emission levels equivalent to those achieved by the use of fuels meeting the requirements of Regulation 14 of Annex VI, we will issue a certificate and notify IMO that your method has been certified.~~

(b) The provisions of this paragraph (b) apply for vessels equipped with controls certified by the U.S. Coast Guard or the Administration of a foreign-flag vessel to achieve emission levels equivalent to those achieved by the use of fuels meeting the applicable fuel sulfur limits of Regulation 14 of Annex VI. Fuels not meeting the applicable fuel sulfur limits of Regulation 14 of Annex VI may be used on such vessels consistent with the provisions of the IAPP certificate, APPS and Annex VI.

* * * * *

161. Amend §1043.95 by revising paragraph (b) to read as follows:

§ 1043.95 Great Lakes provisions.

* * * * *

(b) The following exemption provisions apply for ships qualifying under paragraph (a) of this section:

(1) The fuel-use requirements of this part do not apply through December 31, 2025, if we approved an exemption under this section before [insert effective date of the final rule] based on the use of replacement engines certified to applicable standards under 40 CFR part 1042 corresponding to the date the vessel entered dry dock for service. All other

requirements under this part 1043 continue to apply to exempted vessels, including requirements related to bunker delivery notes.

(2) A marine diesel engine installed to repower a steamship may be a replacement engine under Regulation 13.2.2 of Annex VI. Such an engine may qualify for an exemption from the Tier III NOx standard under Regulation 13.2.2 of Annex VI.

* * * * *

PART 1045—CONTROL OF EMISSIONS FROM SPARK-IGNITION PROPULSION MARINE ENGINES AND VESSELS

162. The authority citation for part 1045 continues to read as follows:
Authority: 42 U.S.C. 7401-7671q.

163. Amend §1045.115 by revising paragraphs (e) and (f) to read as follows:

§ 1045.115 What other requirements apply?

* * * * *

(e) *Adjustable parameters.* Engines that have adjustable parameters must meet all the requirements of this part for any adjustment in the physically adjustable range. ~~An operating parameter is not considered adjustable if you permanently seal it or if it is not normally accessible using ordinary tools.~~ We may require that you set adjustable parameters to any specification within the adjustable range during any testing, including certification testing, production-line testing, or in-use testing. General provisions for adjustable parameters apply as specified in 40 CFR 1068.50.

(f) *Prohibited controls.* You may not design your engines with emission-control devices, systems, or elements of design that cause or contribute to an unreasonable risk to public health, welfare, or safety while operating. For example, ~~this would apply if the an engine~~ may not emits a noxious or toxic substance it would otherwise not emit that contributes to such an unreasonable risk.

* * * * *

164. Amend §1045.205 by revising paragraph (r) to read as follows:

§ 1045.205 What must I include in my application?

* * * * *

(r) Describe all adjustable operating parameters (see §1045.115(e)), including production tolerances. For any operating parameters that do not qualify as adjustable parameters, include a description supporting your conclusion (see 40 CFR 1068.50(c)). Include the following in your description of each adjustable parameter:

(1) For mechanically controlled parameters, include ~~T~~the nominal or recommended setting, ~~(2) T~~the intended physically adjustable range, ~~and (3) T~~the limits or stops used to establish adjustable ranges. ~~(4) Also include I~~information showing why the limits, stops, or other means of inhibiting adjustment are effective in preventing adjustment of parameters on in-use engines to settings outside your intended physically adjustable ranges.

(2) For electronically controlled parameters, describe how your engines are designed to prevent unauthorized adjustments.

* * * * *

165. Amend §1045.801 by revising the definition of “Critical emission-related component” to read as follows:

§ 1045.801 What definitions apply to this part?

* * * * *

Critical emission-related component has the meaning given in 40 CFR 1068.30. ~~means any of the following components:~~

~~(1) Electronic control units, aftertreatment devices, fuel metering components, EGR system components, crankcase ventilation valves, all components related to charge air compression and cooling, and all sensors and actuators associated with any of these components.
(2) Any other component whose primary purpose is to reduce emissions.~~

* * * * *

166. Revise §1045.815 to read as follows:

§ 1045.815 What provisions apply to confidential information?

The provisions of 40 CFR 1068.10 and 1068.11 apply for information you submit under this part.

~~(a) Clearly show what you consider confidential by marking, circling, bracketing, stamping, or some other method.~~

~~(b) We will store your confidential information as described in 40 CFR part 2. Also, we will disclose it only as specified in 40 CFR part 2. This applies both to any information you send us and to any information we collect from inspections, audits, or other site visits.~~

~~(c) If you send us a second copy without the confidential information, we will assume it contains nothing confidential whenever we need to release information from it.~~

~~(d) If you send us information without claiming it is confidential, we may make it available to the public without further notice to you, as described in 40 CFR 2.204.~~

PART 1048—CONTROL OF EMISSIONS FROM NEW, LARGE NONROAD SPARK-IGNITION ENGINES

167. The authority citation for part 1048 continues to read as follows:
Authority: 42 U.S.C. 7401-7671q.

168. Amend §1048.115 by revising paragraphs (e) and (f) to read as follows:

§ 1048.115 What other requirements apply?

* * * * *

(e) *Adjustable parameters.* Engines that have adjustable parameters must meet all the requirements of this part for any adjustment in the physically adjustable range. ~~An operating parameter is not considered adjustable if you permanently seal it or if it is not normally accessible using ordinary tools.~~ We may require that you set adjustable parameters to any specification within the adjustable range during any testing, including certification testing, production-line testing, or in-use testing. General provisions for adjustable parameters apply as specified in 40 CFR 1068.50.

(f) *Prohibited controls.* You may not design your engines with emission control devices, systems, or elements of design that cause or contribute to an unreasonable risk to public health, welfare, or safety while operating. For example, ~~this would apply if the an engine may not~~ emits a noxious or toxic substance it would otherwise not emit that contributes to such an unreasonable risk.

* * * * *

169. Amend §1048.205 by revising paragraph (t) to read as follows:

§ 1048.205 What must I include in my application?

* * * * *

(t) Describe all adjustable operating parameters (see §1048.115(e)), including production tolerances. For any operating parameters that do not qualify as adjustable parameters, include a description supporting your conclusion (see 40 CFR 1068.50(c)). Include the following in your description of each adjustable parameter:

(1) For mechanically controlled parameters, include ~~T~~the nominal or recommended setting, ~~(2) T~~the intended physically adjustable range, and ~~(3) T~~the limits or stops used to establish adjustable ranges. ~~(4) Also include~~ Information showing why the limits, stops, or other means of inhibiting adjustment are effective in preventing adjustment of parameters on in-use engines to settings outside your intended physically adjustable ranges.

(2) For electronically controlled parameters, describe how your engines are designed to prevent unauthorized adjustments.

* * * * *

170. Amend §1048.240 by adding paragraph (f) to read as follows:

§ 1048.240 How do I demonstrate that my engine family complies with exhaust emission standards?

* * * * *

(f) You may alternatively determine and verify deterioration factors based on bench-aged aftertreatment as described in 40 CFR 1036.245 and 1036.246, with the following exceptions:

(1) Apply the percentage of useful life from Table 1 of 40 CFR 1036.246 based on hours of operation rather than vehicle mileage.

(2) Use good engineering judgment to perform verification testing using the procedures of §1048.515 rather than 40 CFR 1036.520. Measure emissions as the equipment goes through its normal operation over the course of the day (or shift-day).

171. Amend §1048.501 by revising paragraph (e)(2) to read as follows:

§ 1048.501 How do I run a valid emission test?

* * * * *

(e) * * *

(2) For engines equipped with carbon canisters that store fuel vapors that will be purged for combustion in the engine, precondition the canister as specified in 40 CFR 86.132-96(h) and then operate the engine for 60 minutes over repeat runs of the duty cycle specified in Appendix II of this part.

* * * * *

172. Amend §1048.620 by revising paragraphs (a)(3), (d), and (e) to read as follows:

§ 1048.620 What are the provisions for exempting large engines fueled by natural gas or liquefied petroleum gas?

(a) * * *

(3) The engine must be in an engine family that has a valid certificate of conformity showing that it meets emission standards for engines of that power rating under 40 CFR part ~~89 or~~ 1039.

* * * * *

(d) Engines exempted under this section are subject to all the requirements affecting engines under 40 CFR part ~~89 or~~ 1039. The requirements and restrictions of 40 CFR part ~~89 or~~ 1039 apply to anyone manufacturing ~~these engines~~ exempted under this section, anyone manufacturing equipment that uses these engines, and all other persons in the same manner as if these were nonroad diesel engines.

(e) You may request an exemption under this section by submitting an application for certification for the engines under 40 CFR part ~~89 or~~ 1039.

173. Amend §1048.801 by revising the definition of “Critical emission-related component” to read as follows:

§ 1048.801 What definitions apply to this part?

* * * * *

Critical emission-related component has the meaning given in 40 CFR 1068.30. ~~means any of the following components:~~

~~(1) Electronic control units, aftertreatment devices, fuel metering components, EGR system components, crankcase ventilation valves, all components related to charge air compression and cooling, and all sensors and actuators associated with any of these components.~~

~~(2) Any other component whose primary purpose is to reduce emissions.~~

* * * * *

174. Revise §1048.815 to read as follows:

§ 1048.815 What provisions apply to confidential information?

The provisions of 40 CFR 1068.10 and 1068.11 apply for information you submit under this part.

~~(a) Clearly show what you consider confidential by marking, circling, bracketing, stamping, or some other method.~~

~~(b) We will store your confidential information as described in 40 CFR part 2. Also, we will disclose it only as specified in 40 CFR part 2. This applies both to any information you send us and to any information we collect from inspections, audits, or other site visits.~~

~~(c) If you send us a second copy without the confidential information, we will assume it contains nothing confidential whenever we need to release information from it.~~

~~(d) If you send us information without claiming it is confidential, we may make it available to the public without further notice to you, as described in 40 CFR 2.204.~~

PART 1051—CONTROL OF EMISSIONS FROM RECREATIONAL ENGINES AND VEHICLES

175. The authority citation for part 1051 continues to read as follows:
Authority: 42 U.S.C. 7401-7671q.

176. Amend §1051.115 by revising paragraphs (c), (d) introductory text, (d)(1), (d)(2) introductory text, and (e) to read as follows:

§ 1051.115 What other requirements apply?

* * * * *

(c) *Adjustable parameters.* Vehicles that have adjustable parameters must meet all the requirements of this part for any adjustment in the physically adjustable range. Note that parameters that control the air-fuel ratio may be treated separately under paragraph (d) of this section. ~~An operating parameter is not considered adjustable if you permanently seal it or if it is not normally accessible using ordinary tools.~~ We may require that you set adjustable parameters to any specification within the adjustable range during any testing, including certification testing, production-line testing, or in-use testing. General provisions for adjustable parameters apply as specified in 40 CFR 1068.50.

(d) *Other adjustments.* The following provisions apply for engines with carburetor jets or needles, and for engines with any other technology involving service to adjust air-fuel ratio that falls within the time and cost specifications of 40 CFR 1068.50(d)(1): ~~This provision applies if an experienced mechanic can change your engine's air-fuel ratio in less than one hour with a few parts whose total cost is under \$50 (in 2001 dollars). Examples include carburetor jets and needles. In the case of carburetor jets and needles, your vehicle must meet all the requirements of this part for any air-fuel ratio within the adjustable range described in paragraph (d)(1) of this section.~~

(1) In your application for certification, specify the physically adjustable range of air-fuel ratios you expect to occur in use. You may specify it in terms of engine parts (such as the carburetor jet size and needle configuration as a function of atmospheric conditions).

(2) ~~This~~ The physically adjustable range (specified in paragraph (d)(1) of this section) must include all air-fuel ratios between the lean limit and the rich limit, unless you can show that some air-fuel ratios will not occur in use.

* * * * *

(e) *Prohibited controls.* You may not design your engines with emission- control devices, systems, or elements of design that cause or contribute to an unreasonable risk to public health, welfare, or safety while operating. For example, ~~this would apply if the~~ an engine may not emit a noxious or toxic substance it would otherwise not emit that contributes to such an unreasonable risk.

* * * * *

177. Amend §1051.205 by revising paragraph (q) to read as follows:

§ 1051.205 What must I include in my application?

* * * * *

(q) Describe all adjustable operating parameters (see §1051.115(e)), including production tolerances. For any operating parameters that do not qualify as adjustable parameters, include a description supporting your conclusion (see 40 CFR 1068.50(c)). Include the following in your description of each adjustable parameter:

(1) For mechanically controlled parameters, include ~~the~~ the nominal or recommended setting, ~~(2) the~~ the intended physically adjustable range, and ~~(3) the~~ the limits or stops used to establish adjustable ranges. ~~(4) Also include~~ information showing why the limits, stops, or other means of inhibiting adjustment are effective in preventing adjustment of parameters on in-use engines to settings outside your intended physically adjustable ranges.

(2) For electronically controlled parameters, describe how your vehicles or engines are designed to prevent unauthorized adjustments.

* * * * *

178. Amend §1051.501 by revising paragraph (c)(2) to read as follows:

§ 1051.501 What procedures must I use to test my vehicles or engines?

* * * * *

(c) * * *

(2) Prior to permeation testing of fuel ~~line~~hose, precondition the fuel line by filling it ~~the hose must be preconditioned by filling the hose~~ with the fuel specified in paragraph (d)(3) of this section, sealing the openings, and soaking ~~the hose~~it for 4 weeks at (23 ± 5) °C. To measure fuel-line permeation emissions, use the equipment and procedures specified in SAE J30 as described in 40 CFR 1060.810. ~~The measurements must be performed at 23 ± 2 °C using~~ Use the fuel specified in paragraph (d)(3) of this section. Perform daily measurements for 14 days, except that you may omit up to two daily measurements in any seven-day period. Maintain an ambient temperature of (23 ± 2) °C throughout the sampling period, except for intervals up to 30 minutes for weight measurements.

* * * * *

179. Amend §1051.515 by revising paragraphs (a)(1), (d)(2)(i), and (d)(3) to read as follows:

§ 1051.515 How do I test my fuel tank for permeation emissions?

* * * * *

(a) * * *

(1) Fill the tank with the fuel specified in §1051.501(d)(2)(i), seal it, and allow it to soak at 28 ± 5 °C for 20 weeks or at (43 ± 5) °C for 10 weeks. ~~Alternatively, the tank may be soaked for a shorter period of time at a higher temperature if you can show that the hydrocarbon permeation rate has stabilized.~~

* * * * *

(d) * * *

(2) * * *

(i) For the preconditioning soak described in §1051.515(a)(1) and fuel slosh durability test described in §1051.515(d)(3), use the fuel specified in 40 CFR 1065.710(b), or the fuel specified in 40 CFR 1065.710(c) blended with 10 percent ethanol by volume. As an alternative, you may use Fuel CE10, which is Fuel C as specified in ASTM D 471-~~98~~ (see 40 CFR 1060.810) blended with 10 percent ethanol by volume.

* * * * *

(3) *Fuel hose permeation.* Use the fuel specified in 40 CFR 1065.710(b), or the fuel specified in 40 CFR 1065.710(c) blended with 10 percent ethanol by volume for permeation testing of fuel lines. As an alternative, you may use Fuel CE10, which is Fuel C as specified in ASTM D 471-~~98~~ (see 40 CFR 1060.810) blended with 10 percent ethanol by volume.

* * * * *

180. Amend §1051.740 by revising paragraph (b)(5) to read as follows:

§ 1051.740 Are there special averaging provisions for snowmobiles?

* * * * *

(b) * * *

(5) Credits can also be calculated for Phase 3 using both sets of standards. Without regard to the trigger level values, if your net emission reduction for the redesignated averaging set exceeds the requirements of Phase 3 in §1051.103 (using both HC+NOX and CO in the Phase 3 equation in §1051.103), then your credits are the difference between the Phase 3 reduction requirement of that section and your calculated value.

181. Amend §1051.801 by revising the definition of “Critical emission-related component” to read as follows:

§ 1051.801 What definitions apply to this part?

* * * * *

Critical emission-related component has the meaning given in 40 CFR 1068.30.~~means any of the following components:~~

- ~~(1) Electronic control units, aftertreatment devices, fuel-metering components, EGR-system components, crankcase-ventilation valves, all components related to charge-air compression and cooling, and all sensors and actuators associated with any of these components.~~
- ~~(2) Any other component whose primary purpose is to reduce emissions.~~

* * * * *

182. Revise §1051.815 to read as follows:

§ 1051.815 What provisions apply to confidential information?

The provisions of 40 CFR 1068.10 and 1068.11 apply for information you submit under this part.

- ~~(a) Clearly show what you consider confidential by marking, circling, bracketing, stamping, or some other method.~~
- ~~(b) We will store your confidential information as described in 40 CFR part 2. Also, we will disclose it only as specified in 40 CFR part 2. This applies both to any information you send us and to any information we collect from inspections, audits, or other site visits.~~
- ~~(c) If you send us a second copy without the confidential information, we will assume it contains nothing confidential whenever we need to release information from it.~~
- ~~(d) If you send us information without claiming it is confidential, we may make it available to the public without further notice to you, as described in 40 CFR 2.204.~~

PART 1054—CONTROL OF EMISSIONS FROM NEW, SMALL NONROAD SPARK-IGNITION ENGINES AND EQUIPMENT

183. The authority citation for part 1054 continues to read as follows:
Authority: 42 U.S.C. 7401-7671q.

184. Amend §1054.115 by revising paragraphs (b) and (d) to read as follows:

§ 1054.115 What other requirements apply?

* * * * *

(b) *Adjustable parameters.* Engines that have adjustable parameters must meet all the requirements of this part for any adjustment in the physically adjustable range. ~~An operating parameter is not considered adjustable if you permanently seal it or if it is not normally accessible using ordinary tools.~~ We may require that you set adjustable parameters to any specification within the adjustable range during any testing, including certification testing, production-line testing, or in-use testing. You may ask us to limit idle-speed or carburetor adjustments to a smaller range than the physically adjustable range if you show us that the engine will not be adjusted outside of this smaller range during in-use operation without significantly degrading engine performance. General provisions for adjustable parameters apply as specified in 40 CFR 1068.50.

* * * * *

(d) *Prohibited controls.* You may not design your engines with emission-control devices, systems, or elements of design that cause or contribute to an unreasonable risk to public health, welfare, or safety while operating. For example, ~~this would apply if the~~ an engine may not emit a noxious or toxic substance it would otherwise not emit that contributes to such an unreasonable risk.

* * * * *

185. Amend §1054.205 by revising paragraph (q) to read as follows:

§ 1054.205 What must I include in my application?

* * * * *

(q) Describe all adjustable operating parameters (see §1054.115(b)), including production tolerances. For any operating parameters that do not qualify as adjustable parameters, include a description supporting your conclusion (see 40 CFR 1068.50(c)). Include the following in your description of each adjustable parameter:

(1) For mechanically controlled parameters, include ~~the~~ the nominal or recommended setting, ~~the~~ the intended physically adjustable range, and ~~the~~ the limits or stops used to establish adjustable ranges. Also include ~~the~~ information showing why the limits, stops, or other means of inhibiting adjustment are effective in preventing adjustment of parameters on in-use engines to settings outside your intended physically adjustable ranges.

(2) For electronically controlled parameters, describe how your engines are designed to prevent unauthorized adjustments.

* * * * *

186. Amend §1054.230 by revising paragraphs (b)(8) and (9) to read as follows:

§ 1054.230 How do I select emission families?

* * * * *

(b) * * *

(8) Method of control for engine operation, other than governing (~~mechanical or electronic~~).

For example, multi-cylinder engines with port fuel injection may not be grouped into an emission family with engines that have a single throttle-body injector or carburetor.

(9) The numerical level of the applicable emission standards. For example, an engine emission family may not include engines certified to different family emission limits, though you may change family emission limits without recertifying as specified in §1054.225.

* * * * *

187. Amend §1054.505 by revising paragraphs (a), (b) introductory text, (b)(2), and (d) to read as follows:

§ 1054.505 How do I test engines?

(a) This section describes how to test engines under steady-state conditions. ~~For handheld engines you must perform tests with discrete mode sampling. For nonhandheld engines we allow you to perform tests with either discrete mode or ramped modal testing methods, as described in 40 CFR Part 1065. You must use the same modal testing method for certification and all other testing you perform for an engine family. If we test your engines to confirm that they meet emission standards, we will use the modal testing method you select for your own testing. If you submit certification test data collected with both discrete mode and ramped modal testing (either in your original application or in an amendment to your application), either method may be used for subsequent testing.~~ We may also perform other testing as allowed by the Clean Air Act.

Conduct duty cycle testing as follows:(1) ~~For discrete mode testing, s~~Sample emissions separately for each mode, then calculate an average emission level for the whole cycle using the weighting factors specified for each mode. Control engine speed as specified in this section. Use one of the following methods for confirming torque values for nonhandheld engines:

(1) ~~i~~ Calculate torque-related cycle statistics and compare with the established criteria as specified in 40 CFR 1065.514 to confirm that the test is valid.

(2) ~~ii~~ Evaluate each mode separately to validate the duty cycle. All torque feedback values recorded during non-idle sampling periods must be within ± 2 percent of the reference value or within ± 0.27 N·m of the reference value, whichever is greater. Also, the mean torque value during non-idle sampling periods must be within ± 1 percent of the reference value or ± 0.12 N·m of the reference value, whichever is greater. Control torque during idle as specified in paragraph (c) of this section.

(2) Unless we specify otherwise, you may simulate the governor for ramped modal testing consistent with good engineering judgment.

(b) Measure emissions by testing ~~the engines~~ on a dynamometer with the test procedures for constant-speed engines in 40 CFR part 1065 while using ~~one of~~ the steady-state duty cycles identified in this paragraph (b) to determine whether it meets the exhaust emission standards specified in §1054.101(a). This paragraph (b) requirement applies for all engines, including those not meeting the definition of “constant-speed engine” in 40 CFR 1065.1001.

* * * * *

(2) For nonhandheld engines designed to idle, use the six-mode duty cycle ~~or the corresponding ramped modal cycle~~ described in paragraph (b)(1) of ~~a~~Appendix II of this part; use the five-mode duty cycle described in paragraph (b)(2) of appendix II of this part for engines that are not designed to idle. Control engine speed during the full-load operating mode as specified in paragraph (d) of this section. For all other modes, control engine speed to within 5 percent of the nominal speed specified in paragraph (d) of this section or let the installed governor (in the production configuration) control engine speed. For all modes except idle, control torque as needed to meet the cycle-validation criteria in paragraph (a)(~~1~~)

of this section. The governor may be adjusted before emission sampling to target the nominal speed identified in paragraph (d) of this section, but the installed governor must control engine speed throughout the emission-sampling period whether the governor is adjusted or not. ~~Note that ramped-modal testing involves continuous sampling, so governor adjustments may not occur during such a test. Note also that our testing may involve running the engine with the governor in the standard configuration even if you adjust the governor as described in this paragraph (a)(2) for certification or production line testing.~~

* * * * *

(d) During full-load operation for nonhandheld engines, operate the engine with the following parameters:

(1) Select an engine speed for testing as follows:

(i) In normal circumstances ~~For engines with a governed speed at full load between 2700 and 4000 rpm,~~ select appropriate test speeds ~~of either 3060 rpm or 3600 rpm that is most appropriate~~ for the engine-emission family. If all the engines in the engine-emission family are used in intermediate-speed equipment, select a test speed of 3060 rpm. The test associated with intermediate-speed operation is referred to as the A Cycle. If all the engines in the engine-emission family are used in rated-speed equipment, select a test speed of 3600 rpm. The test associated with rated-speed operation is referred to as the B Cycle. If an engine-emission family includes engines used in both intermediate-speed equipment and rated-speed equipment, measure emissions at test speeds of both 3060 and 3600 rpm ~~select the test speed for emission data engines that will result in worst-case emissions~~. In unusual circumstances, you may ask to use a test speed different than that specified in this paragraph (d)(1)(i) if it better represents in-use operation.

(ii) For engines with a governed speed below 2700 or above 4000 rpm, ask us to approve one or more test speeds to represent those engines using the provisions for special procedures in 40 CFR 1065.10(c)(2).

* * * * *

188. Amend §1054.801 by:

- a. Revising the definition of “Critical emission-related component”.
- a. Removing the definition of “Discrete mode”.
- b. Revising the definition of “Intermediate-speed equipment”.
- c. Removing the definition of “Ramped-modal”.
- d. Revising the definitions of “Rated-speed equipment” and “Steady-state”.

The revisions read as follows:

§ 1054.801 What definitions apply to this part?

* * * * *

Critical emission-related component has the meaning given in 40 CFR 1068.30. ~~means any of the following components:~~

~~(1) Electronic control units, aftertreatment devices, fuel metering components, EGR system components, crankcase ventilation valves, all components related to charge air compression and cooling, air filters, spark plugs, and all sensors and actuators associated with any of these components.~~

~~(2) Any other component whose primary purpose is to reduce emissions.~~

* * * * *

Discrete mode ~~means relating to the discrete mode type of steady-state test described in §1054.505.~~

Intermediate-speed equipment ~~means~~ includes all nonhandheld equipment in which the installed ~~engine is intended for operation at speeds substantially below 3600 rpm~~ engine's governed speed at full load is below 3330 rpm. It may also include nonhandheld equipment in which the installed engine's governed speed at full load is as high as 3400 rpm.

* * * * *

Ramped-modal ~~means~~ relating to the ~~ramped-modal~~ type of steady-state test described in §1054.505.

Rated-speed equipment ~~means~~ includes all nonhandheld equipment in which the installed ~~engine is intended for operation at a rated speed that is nominally 3600 rpm or higher~~ engine's governed speed at full load is at or above 3400 rpm. It may also include nonhandheld equipment in which the installed engine's governed speed at full load is as low as 3330 rpm.

* * * * *

Steady-state means relating to emission tests in which engine speed and load are held at a finite set of essentially constant values. ~~Steady-state tests are either discrete mode tests or ramped-modal tests.~~

* * * * *

189. Revise §1054.815 to read as follows:

§ 1054.815 What provisions apply to confidential information?

The provisions of 40 CFR 1068.10 and 1068.11 apply for information you submit under this part~~consider confidential~~.

190. Redesignate appendix I to part 1054 as appendix A to part 1054 and amend the redesignated appendix A by revising paragraph (b)(3) introductory text to read as follows:

Appendix ~~A~~I to Part 1054—Summary of Previous Emission Standards

* * * * *

(b) * * *

(3) Note that engines subject to Phase 1 standards were not subject to useful life, deterioration factor, production-line testing, or in-use testing provisions ~~as specified in § 1054.107~~. In addition, engines subject to Phase 1 standards and engines subject to Phase 2 standards were both not subject to the following provisions:

* * * * *

191. Redesignate appendix II to part 1054 as appendix B to part 1054 and revise the redesignated appendix B to read as follows:

Appendix ~~B~~H to Part 1054—Duty Cycles for Laboratory Testing

(a) Test handheld engines with the following steady-state duty cycle:

Table 1 to Appendix B—Duty Cycle for Handheld Engines

G3 Mode Number	Engine Speed ^a	Torque (percent) ^b	Weighting Factors
1	Rated speed	100	0.85
2	Warm idle	0	0.15

^a Test engines at the specified speeds as described in §1054.505.

^b Test engines at 100 percent torque by setting operator demand to maximum. Control torque during idle at its warm idle speed as described in 40 CFR 1065.510.

(b) Test nonhandheld engines with one of the following steady-state duty cycles:

(1) The following duty cycle applies for ~~discrete mode testing~~ engines designed to idle: Table 2 to Appendix B—Duty Cycle for Nonhandheld Engines With Idle

G2 Mode Number ^a	Torque (percent) ^b	Weighting Factors
1	100	0.09
2	75	0.20
3	50	0.29
4	25	0.30
5	10	0.07
6	0	0.05

^a Control engine speed as described in §1054.505. Control engine speed for Mode 6 as described in §1054.505(c) for idle operation.

^b The percent torque is relative to the value established for full-load torque, as described in §1054.505.

(2) The following duty cycle applies for engines that are not designed to idle: Table 3 to Appendix B—Duty Cycle for Nonhandheld Engines Without Idle

<u>Mode Number^a</u>	<u>Torque (percent)^b</u>	<u>Weighting Factors</u>
<u>1</u>	<u>100</u>	<u>0.09</u>
<u>2</u>	<u>75</u>	<u>0.21</u>
<u>3</u>	<u>50</u>	<u>0.31</u>
<u>4</u>	<u>25</u>	<u>0.32</u>
<u>5</u>	<u>10</u>	<u>0.07</u>

^a Control engine speed as described in §1054.505.

^b The percent torque is relative to the value established for full-load torque, as described in §1054.505.

(2) The following duty cycle applies for ramped modal testing:

<u>RMC Mode^a</u>	<u>Time in mode (seconds)</u>	<u>Torque (percent)^{b,e}</u>
<u>1a Steady state</u>	<u>41</u>	<u>0</u>
<u>1b Transition</u>	<u>20</u>	<u>Linear transition</u>
<u>2a Steady state</u>	<u>135</u>	<u>100</u>

2b-Transition	20	Linear transition
3a-Steady state	112	40
3b-Transition	20	Linear transition
4a-Steady state	337	75
4b-Transition	20	Linear transition
5a-Steady state	518	25
5b-Transition	20	Linear transition
6a-Steady state	494	50
6b-Transition	20	Linear transition
7-Steady state	43	0

~~^aControl engine speed as described in §1054.505. Control engine speed for Mode 6 as described in §1054.505(e) for idle operation.~~

~~^bAdvance from one mode to the next within a 20-second transition phase. During the transition phase, command a linear progression from the torque setting of the current mode to the torque setting of the next mode.~~

~~^cThe percent torque is relative to the value established for full-load torque, as described in §1054.505.~~

PART 1060—CONTROL OF EVAPORATIVE EMISSIONS FROM NEW AND IN-USE NONROAD AND STATIONARY EQUIPMENT

192. The authority citation for part 1060 continues to read as follows:
Authority: 42 U.S.C. 7401-7671q.

193. Amend §1060.515 by revising paragraphs (c) and (d) to read as follows:

§ 1060.515 How do I test EPA Nonroad Fuel Lines and EPA Cold-Weather Fuel Lines for permeation emissions?

* * * * *

(c) Except as specified in paragraph (d) of this section, measure fuel line permeation emissions using the equipment and procedures for weight-loss testing specified in SAE J30 or SAE J1527 (incorporated by reference in §1060.810). Start the measurement procedure within 8 hours after draining and refilling the fuel line. Perform the emission test over a sampling period of 14 days. You may omit up to two daily measurements in any seven-day period. Determine your final emission result based on the average of measured values over the 14-day period. Maintain an ambient temperature of (23 ± 2) °C throughout the sampling period, except for intervals up to 30 minutes for daily weight measurements.

(d) For fuel lines with a nominal inner diameter below 5.0 mm, you may alternatively measure fuel line permeation emissions using the equipment and procedures for weight-loss testing specified in SAE J2996 (incorporated by reference in §1060.810). Determine your final emission result based on the average of measured values over the 14-day sampling period. Maintain an ambient temperature of (23 ± 2) °C throughout the sampling period, except for intervals up to 30 minutes for daily weight measurements.

* * * * *

194. Amend §1060.520 by revising paragraph (b)(1) to read as follows:

§ 1060.520 How do I test fuel tanks for permeation emissions?

* * * * *

(b) * * *

(1) Fill the fuel tank to its nominal capacity with the fuel specified in paragraph (e) of this section, seal it, and allow it to soak at (28 ± 5) °C for at least 20 weeks. Alternatively, the fuel tank may be soaked for at least 10 weeks at (43 ± 5) °C. You may count the time of the preconditioning steps in paragraph (a) of this section as part of the preconditioning fuel soak as long as the ambient temperature remains within the specified temperature range and the fuel tank continues to be at least 40 percent full throughout the test; you may add or replace fuel as needed to conduct the specified durability procedures. Void the test if you determine that the fuel tank has any kind of leak.

* * * * *

PART 1065—ENGINE-TESTING PROCEDURES

195. The authority citation for part 1065 continues to read as follows:
 Authority: 42 U.S.C. 7401 - 7671q.

196. Amend §1065.1 by revising paragraphs (a)(1) - (5) and (8) to read as follows:

§1065.1 Applicability.

(a) * * *

(1) Locomotives we regulate under 40 CFR part 1033. ~~For earlier model years, manufacturers may use the test procedures in this part or those specified in 40 CFR part 92 according to § 1065.10.~~

(2) ~~Model year 2010 and later h~~Heavy-duty highway engines we regulate under 40 CFR parts 86 ~~and 1036.~~ ~~For earlier model years, manufacturers may use the test procedures in this part or those specified in 40 CFR part 86, subpart N, according to § 1065.10.~~

(3) Nonroad ~~compression-ignition diesel~~ engines we regulate under 40 CFR part 1039 and stationary diesel engines that are certified to the standards in 40 CFR part 1039 as specified in 40 CFR part 60, subpart IIII. ~~For earlier model years, manufacturers may use the test procedures in this part or those specified in 40 CFR part 89 according to § 1065.10.~~

(4) Marine ~~compression-ignition diesel~~ engines we regulate under 40 CFR part 1042. ~~For earlier model years, manufacturers may use the test procedures in this part or those specified in 40 CFR part 94 according to § 1065.10.~~

(5) Marine spark-ignition engines we regulate under 40 CFR part 1045. ~~For earlier model years, manufacturers may use the test procedures in this part or those specified in 40 CFR part 91 according to § 1065.10.~~

* * * * *

(8) Small nonroad spark-ignition engines we regulate under 40 CFR part 1054 and stationary engines that are certified to the standards in 40 CFR part 1054 as specified in 40 CFR part 60, subpart JJJJ. ~~For earlier model years, manufacturers may use the test procedures in this part or those specified in 40 CFR part 90 according to § 1065.10.~~

* * * * *

197. Amend § 1065.5 by revising paragraphs (a) introductory text and (c) to read as follows:

§ 1065.5 Overview of this part 1065 and its relationship to the standard-setting part.

(a) This part specifies procedures that apply generally to measuring brake-specific emissions from testing various categories of engines. See subpart L of this part for measurement procedures for testing related to standards other than brake-specific emission standards. See the standard-setting part for directions in applying specific provisions in this part for a particular type of engine. Before using this part’s procedures, read the standard-setting part to answer at least the following questions:

* * * * *

(c) The following table shows how this part divides testing specifications into subparts:

Table 1 of § 1065.5—Description of Part 1065 Subparts

This subpart	Describes these specifications or procedures
Subpart A	Applicability and general provisions.
Subpart B	Equipment for testing.
Subpart C	Measurement instruments for testing.
Subpart D	Calibration and performance verifications for measurement systems.

Subpart E	How to prepare engines for testing, including service accumulation.
Subpart F	How to run an emission test over a predetermined duty cycle.
Subpart G	Test procedure calculations.
Subpart H	Fuels, engine fluids, analytical gases, and other calibration standards.
Subpart I	Special procedures related to oxygenated fuels.
Subpart J	How to test with portable emission measurement systems (PEMS).
<u>Subpart L</u>	<u>How to test for unregulated and special pollutants.</u>

* * * * *

198. Amend § 1065.10 by revising paragraph (c)(7)(ii) to read as follows:

§ 1065.10 Other procedures.

* * * * *

(c) * * *

(7) * * *

(ii) *Submission*. Submit requests in writing to the Designated Compliance EPA Program Officer.

* * * * *

199. Amend § 1065.12 by revising paragraph (a) to read as follows:

§ 1065.12 Approval of alternate procedures.

(a) To get approval for an alternate procedure under § 1065.10(c), send the Designated Compliance EPA Program Officer an initial written request describing the alternate procedure and why you believe it is equivalent to the specified procedure. Anyone may request alternate procedure approval. This means that an individual engine manufacturer may request to use an alternate procedure. This also means that an instrument manufacturer may request to have an instrument, equipment, or procedure approved as an alternate procedure to those specified in this part. We may approve your request based on this information alone, whether or not it includes all the information specified in this section. Where we determine that your original submission does not include enough information for us to determine that the alternate procedure is equivalent to the specified procedure, we may ask you to submit supplemental information showing that your alternate procedure is consistently and reliably at least as accurate and repeatable as the specified procedure.

* * * * *

200. Amend § 1065.140 by revising paragraph (b)(2) introductory text, (c)(2) and (6), and (e)(4) to read as follows:

§ 1065.140 Dilution for gaseous and PM constituents.

* * * * *

(b) * * *

(2) Measure these background concentrations the same way you measure diluted exhaust constituents, or measure them in a way that does not affect your ability to demonstrate compliance with the applicable standards in this chapter. For example, you may use the following simplifications for background sampling:

* * * * *

(c) * * *

(2) *Pressure control*. Maintain static pressure at the location where raw exhaust is introduced into the tunnel within ±1.2 kPa of atmospheric pressure. You may use a booster blower to control this pressure. If you test using more careful pressure control and you show by

engineering analysis or by test data that you require this level of control to demonstrate compliance at the applicable standards in this chapter, we will maintain the same level of static pressure control when we test.

* * * * *

(6) *Aqueous condensation*. This paragraph (c)(6) describes how you must address aqueous condensation in the CVS. As described below, you may meet these requirements by preventing or limiting aqueous condensation in the CVS from the exhaust inlet to the last emission sample probe. See that paragraph for provisions related to the CVS between the last emission sample probe and the CVS flow meter. You may heat and/or insulate the dilution tunnel walls, as well as the bulk stream tubing downstream of the tunnel to prevent or limit aqueous condensation. Where we allow aqueous condensation to occur, use good engineering judgment to ensure that the condensation does not affect your ability to demonstrate that your engines comply with the applicable standards in this chapter (see § 1065.10(a)).

* * * * *

(e) * * *

(4) Control sample temperature to a (47 ± 5) °C tolerance, as measured anywhere within 20 cm upstream or downstream of the PM storage media (such as a filter). You may instead measure sample temperature up to 30 cm upstream of the filter or other PM storage media if it is housed within a chamber with temperature controlled to stay within the specified temperature range. Measure ~~this sample~~ temperature with a bare-wire junction thermocouple with wires that are (0.500 ± 0.025) mm diameter, or with another suitable instrument that has equivalent performance.

201. Amend § 1065.170 by revising paragraphs (a)(1) and (c)(1)(ii) and (iii) to read as follows:

§ 1065.170 Batch sampling for gaseous and PM constituents.

* * * * *

(a) * * *

(1) Verify proportional sampling after an emission test as described in § 1065.545. You must exclude from the proportional sampling verification any portion of the test where you are not sampling emissions because the engine is turned off and the batch samplers are not sampling, accounting for exhaust transport delay in the sampling system. Use good engineering judgment to select storage media that will not significantly change measured emission levels (either up or down). For example, do not use sample bags for storing emissions if the bags are permeable with respect to emissions or if they off gas emissions to the extent that it affects your ability to demonstrate compliance with the applicable gaseous emission standards in this chapter. As another example, do not use PM filters that irreversibly absorb or adsorb gases to the extent that it affects your ability to demonstrate compliance with the applicable PM emission standards s in this chapter.

* * * * *

(c) * * *

(1) * * *

(ii) The filter must be circular, with an overall diameter of (46.50 ± 0.6) mm and an exposed diameter of at least 38 mm. See the cassette specifications in paragraph (c)(1)(vii) of this section.
(iii) We highly recommend that you use a pure PTFE filter material that does not have any flow-through support bonded to the back and has an overall thickness of (40 ± 20) µm. An inert polymer ring may be bonded to the periphery of the filter material for support and for sealing

between the filter cassette parts. We consider Polymethylpentene (PMP) and PTFE inert materials for a support ring, but other inert materials may be used. See the cassette specifications in paragraph (c)(1)(vii) of this section. We allow the use of PTFE-coated glass fiber filter material, as long as this filter media selection does not affect your ability to demonstrate compliance with the applicable standards [in this chapter](#), which we base on a pure PTFE filter material. Note that we will use pure PTFE filter material for compliance testing, and we may require you to use pure PTFE filter material for any compliance testing we require, such as for selective enforcement audits.

* * * * *

§ 1065.190—[Amended]

202. Amend § 1065.190 by removing paragraphs (g)(5) and (6).

203. Amend § 1065.210 by revising paragraph (a) to read as follows:

§ 1065.210 Work input and output sensors.

(a) *Application.* Use instruments as specified in this section to measure work inputs and outputs during engine operation. We recommend that you use sensors, transducers, and meters that meet the specifications in Table 1 of § 1065.205. Note that your overall systems for measuring work inputs and outputs must meet the linearity verifications in § 1065.307. We recommend that you measure work inputs and outputs where they cross the system boundary as shown in Figure 1 of § 1065.210. The system boundary is different for air-cooled engines than for liquid-cooled engines. If you choose to measure work before or after a work conversion, relative to the system boundary, use good engineering judgment to estimate any work-conversion losses in a way that avoids overestimation of total work. For example, if it is impractical to instrument the shaft of an exhaust turbine generating electrical work, you may decide to measure its converted electrical work. As another example, you may decide to measure the tractive (i.e., electrical output) power of a locomotive, rather than the brake power of the locomotive engine. In these cases, divide the electrical work by accurate values of electrical generator efficiency ($\eta < 1$), or assume an efficiency of 1 ($\eta = 1$), which would over-estimate brake-specific emissions. For the example of using locomotive tractive power with a generator efficiency of 1 ($\eta = 1$), this means using the tractive power as the brake power in emission calculations. Do not underestimate any work conversion efficiencies for any components outside the system boundary that do not return work into the system boundary. And do not overestimate any work conversion efficiencies for components outside the system boundary that do return work into the system boundary. In all cases, ensure that you are able to accurately demonstrate compliance with the applicable standards [in this chapter](#).

Figure 1065.210-1: Work Inputs, Outputs, and System Boundaries

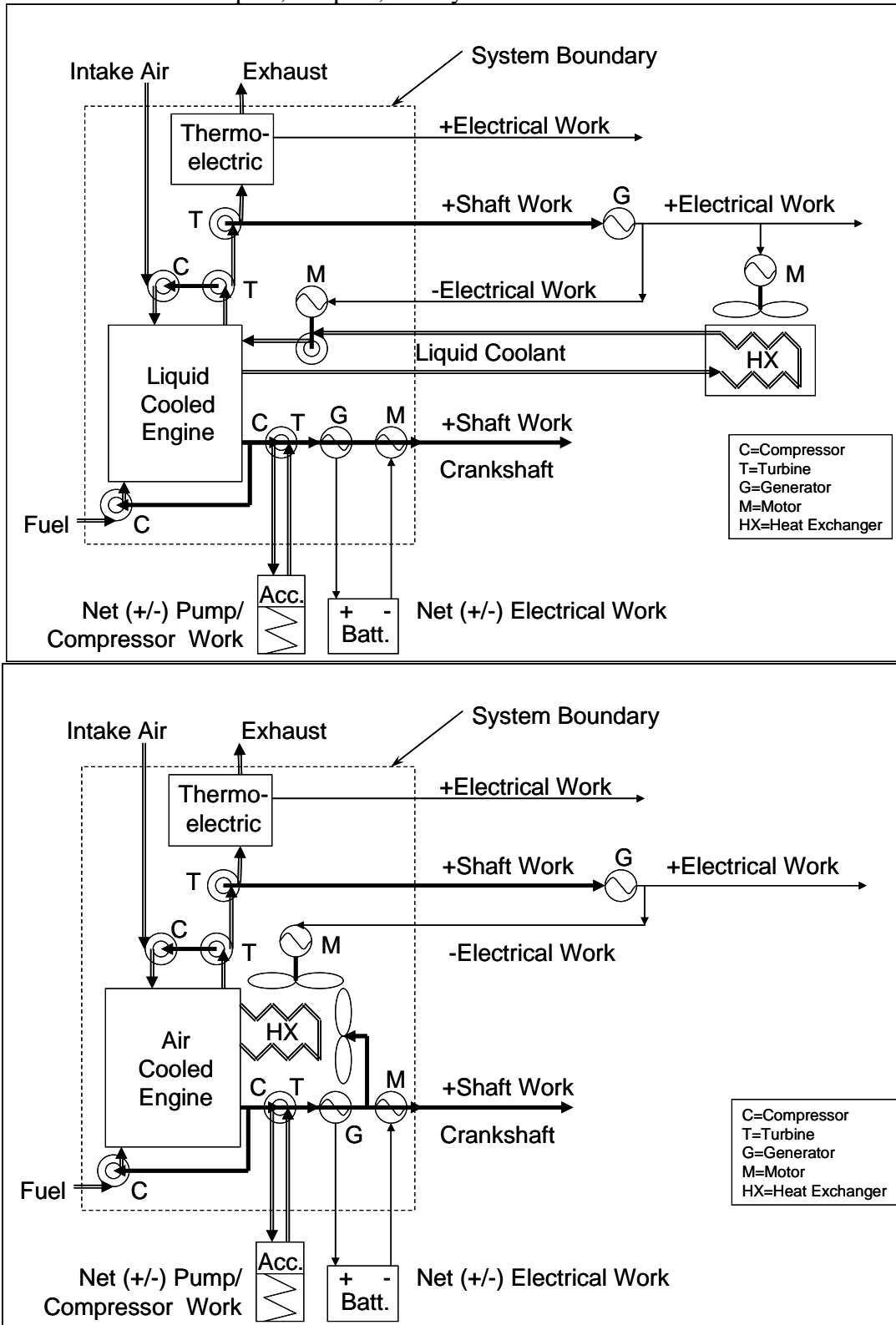

* * * * *

204. Add a new § 1065.274 to read as follows:

§ 1065.274 Zirconium dioxide (ZrO₂) NO_x analyzer.

(a) Application. You may use a zirconia oxide (ZrO₂) analyzer to measure NO_x in raw exhaust for field-testing engines.

(b) Component requirements. We recommend that you use a ZrO₂ analyzer that meets the specifications in Table 1 of § 1065.205. Note that your ZrO₂-based system must meet the linearity verification in § 1065.307.

(c) Species measured. The ZrO₂-based system must be able to measure and report NO and NO₂ together as NO_x. If the ZrO₂-based system cannot measure all of the NO₂, you may develop and apply correction factors based on good engineering judgment to account for this deficiency.

(d) Interference. You must account for NH₃ interference with the NO_x measurement.

205. Amend §1065.284 by revising the section heading to read as follows:

§ 1065.284 Zirconium dioxide (ZrO₂) air-fuel ratio and O₂ analyzer.

* * * * *

206. Add a new § 1065.298 to subpart C to read as follows:

§ 1065.298 Correcting real-time PM measurement based on gravimetric PM filter measurement for field-testing analysis.

(a) Application. You may quantify net PM on a sample medium for field testing with a continuous PM measurement with correction based on gravimetric PM filter measurement.

(b) Measurement principles. Photoacoustic or electrical aerosol instruments used in field-testing typically under-report PM emissions. Apply the verifications and corrections described in this section to meet accuracy requirements.

(c) Component requirements. (1) Gravimetric PM measurement must meet the laboratory measurement requirements of this part 1065, noting that there are specific exceptions to some laboratory requirements and specification for field testing given in § 1065.905(d)(2). In addition to those exceptions, field testing does not require you to verify proportional flow control as specified in § 1065.545. Note also that the linearity requirements of §1065.307 apply only as specified in this section.

(2) Check the calibration and linearity of the photoacoustic and electrical aerosol instruments according to the instrument manufacturer's instructions and the following recommendations:

(i) For photoacoustic instruments we recommend one of the following:

(A) Use a reference elemental carbon-based PM source to calibrate the instrument. Verify the photoacoustic instrument by comparing results either to a gravimetric PM measurement collected on the filter or to an elemental carbon analysis of collected PM.

(B) Use a light absorber that has a known amount of laser light absorption to periodically verify the instrument's calibration factor. Place the light absorber in the path of the laser beam. This verification checks the integrity of the microphone sensitivity, the power of the laser diode, and the performance of the analog-to-digital converter.

(C) Verify that you meet the linearity requirements in Table 1 of § 1065.307 by generating a maximum reference PM mass concentration (verified gravimetrically)

and then using partial-flow sampling to dilute to various evenly distributed concentrations.

(ii) For electrical aerosol instruments we recommend one of the following:

(A) Use reference monodisperse or polydisperse PM-like particles with a mobility diameter or count median diameter greater than 45 nm. Use an electrometer or condensation particle counter that has a d₅₀ at or below 10 nm to verify the reference values.

(B) Verify that you meet the linearity requirements in Table 1 of § 1065.307 using a maximum reference particle concentration, a zero-reference concentration, and at least two other evenly distributed points. Use partial-flow dilution to create the additional reference PM concentrations. The difference between measured values from the electrical aerosol and reference instruments at each point must be no greater than 15 % of the mean value from the two measurements at that point.

(d) Loss correction. You may use PM loss corrections to account for PM loss in the sample handling system.

(e) Correction. Develop a multiplicative correction factor to ensure that total PM measured by photoacoustic or electrical aerosol instruments equate to the gravimetric filter-based total PM measurement. Calculate the correction factor by dividing the mass of PM captured on the gravimetric filter by the quantity represented by the total concentration of PM measured by the instrument multiplied by the time over the test interval multiplied by the gravimetric filter sample flow rate.

207. Amend § 1065.301 by revising paragraph (d) to read as follows:

§ 1065.301 Overview and general provisions.

* * * * *

(d) Use NIST-traceable standards to the tolerances we specify for calibrations and verifications. Where we specify the need to use NIST-traceable standards, you may alternatively use international standards recognized by the CIPM Mutual Recognition Arrangement ~~ask for our approval to use international standards~~ that are not NIST-traceable.

208. Amend § 1065.305 by revising paragraph (d)(10)(ii) to read as follows:

§ 1065.305 Verifications for accuracy, repeatability, and noise.

* * * * *

(d) * * *

(10) * * *

(ii) The measurement deficiency does not adversely affect your ability to demonstrate compliance with the applicable standards in this chapter.

209. Amend § 1065.307 by revising paragraphs (b), (d) introductory text, and (f) to read as follows:

§ 1065.307 Linearity verification.

* * * * *

(b) *Performance requirements.* If a measurement system does not meet the applicable linearity criteria referenced in Table 1 of this section, correct the deficiency by re-calibrating, servicing, or replacing components as needed. Repeat the linearity verification after correcting the deficiency to ensure that the measurement system meets the linearity criteria. Before you may use a measurement system that does not meet linearity criteria, you must demonstrate to us that

the deficiency does not adversely affect your ability to demonstrate compliance with the applicable standards [in this chapter](#).

* * * * *

(d) *Reference signals*. This paragraph (d) describes recommended methods for generating reference values for the linearity-verification protocol in paragraph (c) of this section. Use reference values that simulate actual values, or introduce an actual value and measure it with a reference-measurement system. In the latter case, the reference value is the value reported by the reference-measurement system. Reference values and reference-measurement systems must be NIST-traceable. We recommend using calibration reference quantities that are NIST-traceable within ± 0.5 % uncertainty, if not specified elsewhere in this part 1065. Use the following recommended methods to generate reference values or use good engineering judgment to select a different reference:

* * * * *

(f) *Performance criteria for measurement systems*. Table 1 follows:

TABLE 1 OF § 1065.307—MEASUREMENT SYSTEMS THAT REQUIRE LINEARITY VERIFICATION

Measurement system	Quantity	Linearity criteria			
		$ x_{\min}(a_1-1)+a_0 $	a_1	SEE	r^2
Speed	f_n	$\leq 0.05\% \cdot f_{n\max}$	0.98-1.02	$\leq 2\% \cdot f_{n\max}$	≥ 0.990
Torque	T	$\leq 1\% \cdot T_{\max}$	0.98-1.02	$\leq 2\% \cdot T_{\max}$	≥ 0.990
Electrical power	P	$\leq 1\% \cdot P_{\max}$	0.98-1.02	$\leq 2\% \cdot P_{\max}$	≥ 0.990
Current	I	$\leq 1\% \cdot I_{\max}$	0.98-1.02	$\leq 2\% \cdot I_{\max}$	≥ 0.990
Voltage	U	$\leq 1\% \cdot U_{\max}$	0.98-1.02	$\leq 2\% \cdot U_{\max}$	≥ 0.990
Fuel flow rate	m	$\leq 1\% \cdot m_{\max}$	0.98-1.02	$\leq 2\% \cdot m_{\max}$	≥ 0.990
Fuel mass scale	m	$\leq 0.3\% \cdot m_{\max}$	0.996-1.004	$\leq 0.4\% \cdot m_{\max}$	≥ 0.999
DEF flow rate	m	$\leq 1\% \cdot m_{\max}$	0.98-1.02	$\leq 2\% \cdot m_{\max}$	≥ 0.990
DEF mass scale	m	$\leq 0.3\% \cdot m_{\max}$	0.996-1.004	$\leq 0.4\% \cdot m_{\max}$	≥ 0.999
Intake-air flow rate ^a	n	$\leq 1\% \cdot n_{\max}$	0.98-1.02	$\leq 2\% \cdot n_{\max}$	≥ 0.990
Dilution air flow rate ^a	n	$\leq 1\% \cdot n_{\max}$	0.98-1.02	$\leq 2\% \cdot n_{\max}$	≥ 0.990
Diluted exhaust flow rate ^a	n	$\leq 1\% \cdot n_{\max}$	0.98-1.02	$\leq 2\% \cdot n_{\max}$	≥ 0.990
Raw exhaust flow rate ^a	n	$\leq 1\% \cdot n_{\max}$	0.98-1.02	$\leq 2\% \cdot n_{\max}$	≥ 0.990
Batch sampler flow rates ^a	n	$\leq 1\% \cdot n_{\max}$	0.98-1.02	$\leq 2\% \cdot n_{\max}$	≥ 0.990
Gas dividers	x/x_{span}	$\leq 0.5\% \cdot x_{\max}/x_{\text{span}}$	0.98-1.02	$\leq 2\% \cdot x_{\max}/x_{\text{span}}$	≥ 0.990
Gas analyzers for laboratory testing	x	$\leq 0.5\% \cdot x_{\max}$	0.99-1.01	$\leq 1\% \cdot x_{\max}$	≥ 0.998
Gas analyzers for field testing	x	$\leq 1\% \cdot x_{\max}$	0.99-1.01	$\leq 1\% \cdot x_{\max}$	≥ 0.998
<u>Electrical aerosol analyzer for field testing</u>	\underline{x}	<u>$\leq 5\% \cdot x_{\max}$</u>	<u>0.85-1.15</u>	<u>$\leq 10\% \cdot x_{\max}$</u>	<u>≥ 0.950</u>
<u>Photoacoustic analyzer for field testing</u>	\underline{x}	<u>$\leq 5\% \cdot x_{\max}$</u>	<u>0.90-1.10</u>	<u>$\leq 10\% \cdot x_{\max}$</u>	<u>≥ 0.980</u>
PM balance	m	$\leq 1\% \cdot m_{\max}$	0.99-1.01	$\leq 1\% \cdot m_{\max}$	≥ 0.998
Pressures	p	$\leq 1\% \cdot p_{\max}$	0.99-1.01	$\leq 1\% \cdot p_{\max}$	≥ 0.998
Dewpoint for intake air, PM-stabilization and balance environments	T_{dew}	$\leq 0.5\% \cdot T_{\text{dewmax}}$	0.99-1.01	$\leq 0.5\% \cdot T_{\text{dewmax}}$	≥ 0.998
Other dewpoint measurements	T_{dew}	$\leq 1\% \cdot T_{\text{dewmax}}$	0.99-1.01	$\leq 1\% \cdot T_{\text{dewmax}}$	≥ 0.998
Analog-to-digital conversion of temperature signals	T	$\leq 1\% \cdot T_{\max}$	0.99-1.01	$\leq 1\% \cdot T_{\max}$	≥ 0.998

^aFor flow meters that determine volumetric flow rate, V_{std} , you may substitute V_{std} for n as the quantity and substitute V_{stdmax} for n_{\max} .

* * * * *

210. Amend § 1065.308 by revising paragraph (e)(3) to read as follows:

§ 1065.308 Continuous gas analyzer system-response and updating-recording verification—for gas analyzers not continuously compensated for other gas species.

* * * * *

(e) * * *

(3) If a measurement system fails the criteria in paragraphs (e)(1) and (2) of this section, you may use the measurement system only if the deficiency does not adversely affect your ability to show compliance with the applicable standards in this chapter.

* * * * *

211. Amend § 1065.309 by revising paragraph (e)(3) to read as follows:

§ 1065.309 Continuous gas analyzer system-response and updating-recording verification—for gas analyzers continuously compensated for other gas species.

* * * * *

(e) * * *

(3) If a measurement system fails the criteria in paragraphs (e)(1) and (2) of this section, you may use the measurement system only if the deficiency does not adversely affect your ability to show compliance with the applicable standards in this chapter.

* * * * *

212. Amend § 1065.315 by revising paragraphs (a)(1) - (3) and (b) to read as follows:

§ 1065.315 Pressure, temperature, and dewpoint calibration.

(a) * * *

(1) *Pressure*. We recommend temperature-compensated, digital-pneumatic, or deadweight pressure calibrators, with data-logging capabilities to minimize transcription errors. We recommend using calibration reference quantities that are NIST-traceable within ± 0.5 % uncertainty.

(2) *Temperature*. We recommend digital dry-block or stirred-liquid temperature calibrators, with data logging capabilities to minimize transcription errors. We recommend using calibration reference quantities that are NIST-traceable within ± 0.5 % uncertainty. You may perform linearity verification for temperature measurement systems with thermocouples, RTDs, and thermistors by removing the sensor from the system and using a simulator in its place. Use a NIST-traceable simulator that is independently calibrated and, as appropriate, cold-junction compensated. The simulator uncertainty scaled to absolute temperature must be less than 0.5 % of T_{max} . If you use this option, you must use sensors that the supplier states are accurate to better than 0.5 % of T_{max} compared with their standard calibration curve.

(3) *Dewpoint*. We recommend a minimum of three different temperature-equilibrated and temperature-monitored calibration salt solutions in containers that seal completely around the dewpoint sensor. We recommend using calibration reference quantities that are NIST-traceable within ± 0.5 % uncertainty.

(b) You may remove system components for off-site calibration. We recommend specifying calibration reference quantities that are NIST-traceable within ± 0.5 % uncertainty.

213. Amend § 1065.320 by revising paragraph (c) to read as follows:

§ 1065.320 Fuel-flow calibration.

* * * * *

(c) You may remove system components for off-site calibration. When installing a flow meter with an off-site calibration, we recommend that you consider the effects of the tubing configuration upstream and downstream of the flow meter. We recommend specifying calibration reference quantities that are NIST-traceable within ± 0.5 % uncertainty.

214. Amend § 1065.325 by revising paragraphs (a) and (b) to read as follows:

§ 1065.325 Intake-flow calibration.

(a) Calibrate intake-air flow meters upon initial installation. Follow the instrument manufacturer's instructions and use good engineering judgment to repeat the calibration. We

recommend using a calibration subsonic venturi, ultrasonic flow meter or laminar flow element. We recommend using calibration reference quantities that are NIST-traceable within ± 0.5 % uncertainty.

(b) You may remove system components for off-site calibration. When installing a flow meter with an off-site calibration, we recommend that you consider the effects of the tubing configuration upstream and downstream of the flow meter. We recommend specifying calibration reference quantities that are NIST-traceable within ± 0.5 % uncertainty.

* * * * *

215. Amend § 1065.330 by revising paragraphs (a) and (b) to read as follows:

§ 1065.330 Exhaust-flow calibration.

(a) Calibrate exhaust-flow meters upon initial installation. Follow the instrument manufacturer's instructions and use good engineering judgment to repeat the calibration. We recommend that you use a calibration subsonic venturi or ultrasonic flow meter and simulate exhaust temperatures by incorporating a heat exchanger between the calibration meter and the exhaust-flow meter. If you can demonstrate that the flow meter to be calibrated is insensitive to exhaust temperatures, you may use other reference meters such as laminar flow elements, which are not commonly designed to withstand typical raw exhaust temperatures. We recommend using calibration reference quantities that are NIST-traceable within ± 0.5 % uncertainty.

(b) You may remove system components for off-site calibration. When installing a flow meter with an off-site calibration, we recommend that you consider the effects of the tubing configuration upstream and downstream of the flow meter. We recommend specifying calibration reference quantities that are NIST-traceable within ± 0.5 % uncertainty.

* * * * *

216. Amend § 1065.345 by revising paragraph (d) to read as follows:

§ 1065.345 Vacuum-side leak verification.

* * * * *

(d) *Dilution-of-span-gas leak test.* You may use any gas analyzer for this test. If you use a FID for this test, correct for any HC contamination in the sampling system according to § 1065.660. If you use an O₂ analyzer described in § 1065.280 for this test, you may use purified N₂ to detect a leak. To avoid misleading results from this test, we recommend using only analyzers that have a repeatability of 0.5 % or better at the span-reference gas concentration used for this test.

Perform a vacuum-side leak test as follows:

- (1) Prepare a gas analyzer as you would for emission testing.
- (2) Supply reference span-gas to the analyzer span port and record the measured value.
- (3) Route overflow reference span-gas to the inlet of the sample probe or at a tee fitting in the transfer line near the exit of the probe. You may use a valve upstream of the overflow fitting to prevent overflow of reference span-gas out of the inlet of the probe, but you must then provide an overflow vent in the overflow supply line.
- (4) Verify that the measured overflow reference span-gas concentration is within ± 0.5 % of the concentration measured in paragraph (d)(2) of this section. A measured value lower than expected indicates a leak, but a value higher than expected may indicate a problem with the reference span-gas or the analyzer itself. A measured value higher than expected does not indicate a leak.

* * * * *

217. Amend § 1065.350 by revising paragraph (e)(1) to read as follows:

§ 1065.350 H₂O interference verification for CO₂ NDIR analyzers.

* * * * *

(e) * * *

(1) You may omit this verification if you can show by engineering analysis that for your CO₂ sampling system and your emission-calculation procedures, the H₂O interference for your CO₂ NDIR analyzer always affects your brake-specific emission results within ±0.5 % of each of the applicable standards in this chapter. This specification also applies for vehicle testing, except that it relates to emission results in g/mile or g/kilometer.

* * * * *

218. Amend § 1065.405 by revising paragraph (a) to read as follows:

§ 1065.405 Test engine preparation and maintenance.

* * * * *

(a) If you are testing an emission-data engine for certification, make sure it is built to represent production engines, consistent with paragraph (f) of this section.

(1) This includes governors that you normally install on production engines. Production engines should also be tested with their installed governors. If your engine is equipped with multiple user-selectable governor types and if the governor does not manipulate the emission control system (i.e., the governor only modulates an “operator demand” signal such as commanded fuel rate, torque, or power), choose the governor type that allows the test cell to most accurately follow the duty cycle. If the governor manipulates the emission control system, treat it as an adjustable parameter. See paragraph (b) of this section for guidance on setting adjustable parameters. If you do not install governors on production engines, simulate a governor that is representative of a governor that others will install on your production engines.

(2) In certain circumstances, you may incorporate test cell components to simulate an in-use configuration, consistent with good engineering judgment. For example, §§ 1065.122 and 1065.125 allow the use of test cell components to represent engine cooling and intake air systems.

(3) The provisions in § 1065.110(e) also apply to emission-data engines for certification.

(4) For engines using SCR, use any size DEF tank and fuel tank. We may require you to give us a production-type DEF tank, including any associated sensors, for our testing.

* * * * *

219. Amend § 1065.410 by revising paragraph (c) to read as follows:

§ 1065.410 Maintenance limits for stabilized test engines.

* * * * *

(c) If you inspect an engine, keep a record of the inspection and update your application for certification to document any changes that result. You may use any kind of equipment, instrument, or tool that is available at dealerships and other service outlets to identify malfunctioning components or perform maintenance. You may inspect using electronic tools to monitor engine performance, but only if the information is readable without specialized equipment.

* * * * *

220. Amend § 1065.501 by revising paragraph (a) introductory text to read as follows:
§ 1065.501 Overview.

(a) Use the procedures detailed in this subpart to measure engine emissions over a specified duty cycle. Refer to subpart J of this part for field test procedures that describe how to measure emissions during in-use engine operation. Refer to subpart L of this part for measurement procedures for testing related to standards other than brake-specific emission standards. This section describes how to:--

* * * * *

221. Amend § 1065.510 by revising paragraphs (a) introductory text, (b) introductory text, (b)(4)-(6), (c)(2), and (g)(2)(i) to read as follows:

§ 1065.510 Engine mapping.

(a) *Applicability, scope, and frequency.* An engine map is a data set that consists of a series of paired data points that represent the maximum brake torque versus engine speed, measured at the engine's primary output shaft. Map your engine if the standard-setting part requires engine mapping to generate a duty cycle for your engine configuration. Map your engine while it is connected to a dynamometer or other device that can absorb work output from the engine's primary output shaft according to § 1065.110. Configure any auxiliary work inputs and outputs such as hybrid, turbo-compounding, or thermoelectric systems to represent their in-use configurations, and use the same configuration for emission testing. See Figure 1 of § 1065.210. This may involve configuring initial states of charge and rates and times of auxiliary-work inputs and outputs. We recommend that you contact the Designated Compliance-EPA Program Officer before testing to determine how you should configure any auxiliary-work inputs and outputs. If your engine has an auxiliary emission control device to reduce torque output that may activate during engine mapping, turn it off before mapping. Use the most recent engine map to transform a normalized duty cycle from the standard-setting part to a reference duty cycle specific to your engine. Normalized duty cycles are specified in the standard-setting part. You may update an engine map at any time by repeating the engine-mapping procedure. You must map or re-map an engine before a test if any of the following apply:

* * * * *

(b) Mapping variable-speed engines. Map variable-speed engines using the procedure in this paragraph (b). Note that under § 1065.10(c) we may allow or require you to use "other procedures" if the specified procedure results in unrepresentative testing or if your engine cannot be tested using the specified procedure. If the engine has a user-adjustable idle speed setpoint, you may set it to its minimum adjustable value for this mapping procedure and the resulting map may be used for any test, regardless of where it is set for running each test.

* * * * *

(4) Operate the engine at the minimum mapped speed. A minimum mapped speed equal to (95 ±1) % of its warm idle speed determined in paragraph (b)(3) of this section may be used for any engine or test. A higher minimum mapped speed may be used if all the duty cycles that the engine is subject to have a minimum reference speed higher than the warm idle speed determined in paragraph (b)(3). In this case you may use a minimum mapped speed equal to (95 ±1) % of the lowest minimum reference speed in all the duty cycles the engine is subject to. Set operator demand to maximum and control engine speed at ~~(95 ±1) % of its warm idle speed determined above~~ this minimum mapped speed for at least 15 seconds. Set operator demand to maximum and control engine speed at (95 ±1) % of its warm idle speed determined in paragraph (b)(3)(i) of this section ~~above~~ for at least 15 seconds. ~~For engines~~

with reference duty cycles whose lowest speed is greater than warm idle speed, you may start the map at (95 ± 1) % of the lowest reference speed.

(5) ~~Perform one of the following:~~ Perform a continuous or discrete engine map as described in paragraphs (b)(5)(i) or (ii) of this section. A continuous engine map may be used for any engine. A discrete engine map may be used for engines subject only to steady-state duty cycles. The check point speed referenced in these paragraphs is described in paragraph (b)(5)(iii) of this section. Use linear interpolation between the series of speed/torque points generated by either of these maps to determine intermediate torque values. Use the series of speed/torque points generated by either of these maps to generate the power map as described in paragraph (e) of this section.

(i) *Continuous engine map.* Begin recording mean feedback speed and torque at 1 Hz or more frequently and increase speed at a constant rate such that it takes (4 to 6) min to sweep from the minimum mapped speed described in paragraphs (b)(4) of this section to the check point speed described in paragraph (b)(5)(iii) of this section. Use good engineering judgment to determine when to stop recording data to ensure that the sweep is complete. In most cases, this means that you can stop the sweep at any point after the power falls to 50 % of the maximum value.

(ii) *Discrete engine map.* (i) ~~For any engine subject only to steady-state duty cycles, you may perform an engine map by using discrete speeds.~~ Select at least 20 evenly spaced setpoints from the minimum mapped speed described in paragraphs (b)(4) of this section ~~95 % of warm idle speed~~ to the check point speed described in paragraph (b)(5)(iii) of this section ~~highest speed above maximum power at which 50 % of maximum power occurs. We refer to this 50 % speed as the check point speed as described in paragraph (b)(5)(iii) of this section.~~ At each setpoint, stabilize speed and allow torque to stabilize. We recommend that you stabilize an engine for at least 15 seconds at each setpoint and record the mean feedback speed and torque of the last (4 to 6) seconds. Record the mean speed and torque at each setpoint. ~~Use linear interpolation to determine intermediate speeds and torques. Use this series of speeds and torques to generate the power map as described in paragraph (e) of this section.~~ (ii) ~~For any variable-speed engine, you may perform an engine map by using a continuous sweep of speed by continuing to record the mean feedback speed and torque at 1 Hz or more frequently and increasing speed at a constant rate such that it takes (4 to 6) min to sweep from 95 % of warm idle speed to the check point speed as described in paragraph (b)(5)(iii) of this section. Use good engineering judgment to determine when to stop recording data to ensure that the sweep is complete. In most cases, this means that you can stop the sweep at any point after the power falls to 50 % of the maximum value. From the series of mean speed and maximum torque values, use linear interpolation to determine intermediate values. Use this series of speeds and torques to generate the power map as described in paragraph (e) of this section.~~

(iii) The check point speed of the map is the highest speed above maximum power at which 50 % of maximum power occurs. If this speed is unsafe or unachievable (e.g., for ungoverned engines or engines that do not operate at that point), use good engineering judgment to map up to the maximum safe speed or maximum achievable speed. For discrete mapping, if the engine cannot be mapped to the check point speed, make sure the map includes at least 20 points from 95 % of warm idle to the maximum mapped speed. For continuous mapping, if the engine cannot be mapped to the check point speed, verify that the sweep time from 95 % of warm idle to the maximum mapped speed is (4 to 6) min.

(iv) Note that under § 1065.10(c)(1) we may allow you to disregard portions of the map when selecting maximum test speed if the specified procedure would result in a duty cycle that does not represent in-use operation.

(6) ~~Use one of the following methods to determine~~ Determine warm high-idle speed for engines with a high-speed governor. You may skip this if they ~~are~~ engine is not subject to transient testing with a duty cycle that includes reference speed values above 100 %. ~~(i) You may use a manufacturer-declared warm high-idle speed if the engine is electronically governed. For engines with a high-speed governor that regulates speed by disabling and enabling fuel or ignition at two shuts off torque output at a manufacturer specified speed and reactivates at a lower manufacturer-specified speeds (such as engines that use ignition cut off for governing), declare the middle of the this specified speed range as the warm high-idle speed. You may alternatively m~~ (ii) Measure the warm high-idle speed using the following procedure:

(A) Run an operating point targeting zero torque.

(A) Set operator demand to maximum and use the dynamometer to target zero torque on the engine's primary output shaft.

(B) Wait for the engine governor and dynamometer to stabilize. We recommend that you stabilize for at least 15 seconds.

(C) Record 1 Hz means of the feedback speed and torque for at least 30 seconds. You may record means at a higher frequency as long as there are no gaps in the recorded data. For engines with a high-speed governor that regulates speed by disabling and enabling fuel or ignition, you may need to extend this stabilization period to include at least one disabling event at the higher speed and one enabling event at the lower speed.

(D) Determine if the feedback speed is stable over the recording period. The feedback speed is considered stable if all the recorded 1 Hz means are within $\pm 2\%$ of the mean feedback speed over the recording period. If the feedback speed is not stable because of the dynamometer, void the results and repeat measurements after making any necessary corrections. You may void and repeat the entire map sequence, or you may void and replace only the results for establishing warm high-idle speed; use good engineering judgment to warm-up the engine before repeating measurements.

(E) If the feedback speed is stable, use the mean feedback speed over the recording period as the measured speed for this operating point.

(F) If the feedback speed is not stable because of the engine, determine the mean as the value representing the midpoint between the observed maximum and minimum recorded feedback speed.

(G) If the mean feedback torque over the recording period is within $(0 \pm 1)\%$ of $T_{\max \text{ mapped}}$, use the measured speed for this operating point as the warm high-idle speed.

Otherwise, continue testing as described in paragraph (b)(6)(ii) of this section. If the mean feedback torque is within $\pm 1\%$ of $T_{\max \text{ mapped}}$, you may use the observed mean feedback speed at that point as the measured warm high-idle speed. ~~(B) If the engine is unstable as a result of in-use production components (such as engines that use ignition cut-off for governing, as opposed to unstable dynamometer operation), you must use the mean feedback speed from paragraph (b)(6)(ii)(A) of this section as the measured warm high idle speed. The engine is considered unstable if any of the 1 Hz speed feedback values are not within $\pm 2\%$ of the calculated mean feedback speed. We recommend that you determine the mean as the value representing the midpoint between the observed maximum and minimum recorded feedback speed.~~

(ii) Run a second operating point targeting a positive torque. Follow the same procedure in paragraphs (b)(6)(i)(A) through (F) of this section, except that (C) If your

~~dynamometer is not capable of achieving a mean feedback torque within $\pm 1\%$ of T_{\max} mapped, operate the engine at a second point with operator demand set to maximum with the dynamometer is set to target a torque equal to the ~~recorded~~ mean feedback torque over the recording period from ~~on~~ the previous operating point plus 20 % of T_{\max} mapped. Use this data point and the data point from paragraph (b)(6)(ii)(A) of this section to extrapolate the engine speed where torque is equal to zero.~~

(iii) Use the mean feedback speed and torque values from paragraphs (b)(6)(i) and (ii) of this section to determine the warm high-idle speed. If the two speed values are the same, use that value as the warm high-idle speed. Otherwise, use a linear equation passing through these two speed-torque points and extrapolate to solve for the speed at zero torque and use this speed intercept value as the warm high-idle speed.

~~(iv)~~ You may use a manufacturer-declared T_{\max} instead of the measured T_{\max} mapped. If you do this, ~~or if you are able to determine mean feedback speed as described in paragraphs (b)(6)(ii)(A) and (B) of this section,~~ you may also measure the warm high-idle speed as described in this paragraph (b)(6) before running the operating point and speed sweeps specified in paragraphs (b)(4) and (5) of this section.

* * * * *

(c) * * *

(2) Map the amount of negative torque required to motor the engine by repeating paragraph (b) of this section with minimum operator demand, as applicable. You may start the negative torque map at either the minimum or maximum speed from paragraph (b) of this section.

* * * * *

(g) * * *

(2) * * *

(i) Perform an engine map by using a series of continuous sweeps to cover the engine's full range of operating speeds. Prepare the engine for hybrid-active mapping by ensuring that the RESS state of charge is representative of normal operation. Perform the sweep as specified in paragraph (b)(5)(i) of this section, but stop the sweep to charge the RESS when the power measured from the RESS drops below the expected maximum power from the RESS by more than 2 % of total system power (including engine and RESS power). Unless good engineering judgment indicates otherwise, assume that the expected maximum power from the RESS is equal to the measured RESS power at the start of the sweep segment. For example, if the 3-second rolling average of total engine-RESS power is 200 kW and the power from the RESS at the beginning of the sweep segment is 50 kW, once the power from the RESS reaches 46 kW, stop the sweep to charge the RESS. Note that this assumption is not valid where the hybrid motor is torque-limited. Calculate total system power as a 3-second rolling average of instantaneous total system power. After each charging event, stabilize the engine for 15 seconds at the speed at which you ended the previous segment with operator demand set to maximum before continuing the sweep from that speed. Repeat the cycle of charging, mapping, and recharging until you have completed the engine map. You may shut down the system or include other operation between segments to be consistent with the intent of this paragraph (g)(2)(i). For example, for systems in which continuous charging and discharging can overheat batteries to an extent that affects performance, you may operate the engine at zero power from the RESS for enough time after the system is recharged to allow the batteries to cool. Use good engineering judgment to smooth the torque curve to eliminate discontinuities between map intervals.

* * * * *

222. Amend § 1065.512 by revising paragraph (b)(1) to read as follows:

§ 1065.512 Duty cycle generation.

* * * * *

(b) * * *

(1) *Engine speed for variable-speed engines.* For variable-speed engines, normalized speed may be expressed as a percentage between warm idle speed, f_{idle} , and maximum test speed, f_{ntest} , or speed may be expressed by referring to a defined speed by name, such as “warm idle,” “intermediate speed,” or “A,” “B,” or “C” speed. Section 1065.610 describes how to transform these normalized values into a sequence of reference speeds, f_{ref} . Running duty cycles with negative or small normalized speed values near warm idle speed may cause low-speed idle governors to activate and the engine torque to exceed the reference torque even though the operator demand is at a minimum. In such cases, we recommend controlling the dynamometer so it gives priority to follow the reference torque instead of the reference speed and let the engine govern the speed. Note that the cycle-validation criteria in § 1065.514 allow an engine to govern itself. This allowance permits you to test engines with enhanced-idle devices and to simulate the effects of transmissions such as automatic transmissions. For example, an enhanced-idle device might be an idle speed value that is normally commanded only under cold-start conditions to quickly warm up the engine and aftertreatment devices. In this case, negative and very low normalized speeds will generate reference speeds below this higher enhanced-idle speed. You may do either of the following ~~with~~ when using enhanced-idle devices:

(i) Control the dynamometer so it gives priority to follow the reference torque, controlling the operator demand so it gives priority to follow reference speed and let the engine govern the speed when the operator demand is at minimum.

(ii) While running an engine where the ~~electronic control module~~ **ECM** broadcasts an enhanced-idle speed that is above the denormalized speed, use the broadcast speed as the reference speed. Use these new reference points for duty-cycle validation. This does not affect how you determine denormalized reference torque in paragraph (b)(2) of this section.

(iii) If an ECM broadcast signal is not available, perform one or more practice cycles to determine the enhanced-idle speed as a function of cycle time. Generate the reference cycle as you normally would but replace any reference speed that is lower than the enhanced-idle speed with the enhanced-idle speed. This does not affect how you determine denormalized reference torque in paragraph (b)(2) of this section.

* * * * *

223. Amend § 1065.514 by revising paragraph (d) to read as follows

§ 1065.514 Cycle-validation criteria for operation over specified duty cycles.

* * * * *

(d) *Omitting additional points.* Besides engine cranking, you may omit additional points from cycle-validation statistics as described in the following table:

TABLE 1 OF § 1065.514—PERMISSIBLE CRITERIA FOR OMITTING POINTS FROM DUTY-CYCLE REGRESSION STATISTICS

For reference duty cycles that are specified in terms of speed and torque (f_{nref} , T_{ref})		
When operator demand is at its...	you may omit...	if...
minimum	power and torque	$T_{ref} < 0\%$ (motoring).
minimum	power and speed	$f_{nref} = 0\%$ (idle speed) and $T_{ref} = 0\%$ (idle torque) and $T_{ref} - (2\% \cdot T_{max\ mapped}) < T < T_{ref} + (2\% \cdot T_{max\ mapped})$.
<u>minimum</u>	<u>power and speed</u>	<u>$f_{nref} < \text{enhanced-idle speed}^a$ and $T_{ref} > 0\%$.</u>
minimum	power and either torque or speed	$f_n > f_{nref}$ or $T > T_{ref}$ but not if $f_n > (f_{nref} \cdot 102\%)$ and $T > T_{ref} + (2\% \cdot T_{max\ mapped})$.
maximum	power and either torque or speed	$f_n < f_{nref}$ or $T < T_{ref}$ but not if $f_n < (f_{nref} \cdot 98\%)$ and $T < T_{ref} - (2\% \cdot T_{max\ mapped})$.
For reference duty cycles that are specified in terms of speed and power (f_{nref} , P_{ref})		
When operator demand is at its...	you may omit...	if...
minimum	power and torque	$P_{ref} < 0\%$ (motoring).
minimum	power and speed	$f_{nref} = 0\%$ (idle speed) and $P_{ref} = 0\%$ (idle power) and $P_{ref} - (2\% \cdot P_{max\ mapped}) < P < P_{ref} + (2\% \cdot P_{max\ mapped})$.
minimum	power and either torque or speed	$f_n > f_{nref}$ or $P > P_{ref}$ but not if $f_n > (f_{nref} \cdot 102\%)$ and $P > P_{ref} + (2\% \cdot P_{max\ mapped})$.
maximum	power and either torque or speed	$f_n < f_{nref}$ or $P < P_{ref}$ but not if $f_n < (f_{nref} \cdot 98\%)$ and $P < P_{ref} - (2\% \cdot P_{max\ mapped})$.

^aEnhanced-idle speed determined from ECM broadcast or practice cycle.

* * * * *

224. Amend § 1065.545 by revising paragraphs (a) and (b) introductory text to read as follows:

§ 1065.545 Verification of proportional flow control for batch sampling.

* * * * *

(a) For any pair of sample and total flow rates, use continuous recorded sample and total flow rates data or 1 Hz means. Total flow rate means the raw exhaust flow rate for raw exhaust sampling and the dilute exhaust flow rate for CVS sampling, ~~or their 1 Hz means with the statistical calculations in § 1065.602 forcing the intercept through zero. Determine.~~ For each test interval, determine the standard error of the estimate, *SEE*, of the sample flow rate versus the total flow rate as described in § 1065.602, forcing the intercept to zero. Determine the mean sample flow rate over each test interval as described in § 1065.602. For each test interval, demonstrate that *SEE* is at or below ~~was less than or equal to~~ 3.5 % of the mean sample flow rate.

(b) For any pair of sample and total flow rates, use continuous recorded data or 1 Hz means sample and total flow rates. Total flow rate means the raw exhaust flow rate for raw exhaust sampling and the dilute exhaust flow rate for CVS sampling, ~~or their 1 Hz means to.~~ For each test interval, demonstrate that each flow rate was is constant within $\pm 2.5\%$ of its respective mean or target flow rate. You may use the following options instead of recording the respective flow rate of each type of meter:

* * * * *

225. Amend § 1065.610 by revising paragraph (c)(2) to read as follows:

§ 1065.610 Duty cycle generation.

* * * * *

(c) * * *

(2) A, B, C, and ~~C~~ D speeds. If your normalized duty cycle specifies speeds as A, B, C, or D values, use your power-versus-speed curve to determine the lowest speed below maximum power at which 50 % of maximum power occurs. Denote this value as n_{lo} . Take n_{lo} to be warm idle speed if all power points at speeds below the maximum power speed are higher than 50 % of maximum power. Also determine the highest speed above maximum power at which 70 % of maximum power occurs. Denote this value as n_{hi} . If all power points at speeds above the maximum power speed are higher than 70 % of maximum power, take n_{hi} to be the declared maximum safe engine speed or the declared maximum representative engine speed, whichever is lower. Use n_{hi} and n_{lo} to calculate reference values for A, B, C, or D speeds as follows:

$$f_{nrefA} = 0.25 \cdot (n_{hi} - n_{lo}) + n_{lo}$$

Eq. 1065.610-4

$$f_{nrefB} = 0.50 \cdot (n_{hi} - n_{lo}) + n_{lo}$$

Eq. 1065.610-5

$$f_{nrefC} = 0.75 \cdot (n_{hi} - n_{lo}) + n_{lo}$$

Eq. 1065.610-6

$$f_{nrefD} = 0.15 \cdot (n_{hi} - n_{lo}) + n_{lo}$$

Eq. 1065.610-7

Example:

$$n_{lo} = 1005 \text{ r/min}$$

$$n_{hi} = 2385 \text{ r/min}$$

$$f_{nrefA} = 0.25 \cdot (2385 - 1005) + 1005$$

$$f_{nrefB} = 0.50 \cdot (2385 - 1005) + 1005$$

$$f_{nrefC} = 0.75 \cdot (2385 - 1005) + 1005$$

$$f_{nrefD} = 0.15 \cdot (2385 - 1005) + 1005$$

$$f_{nrefA} = 1350 \text{ r/min}$$

$$f_{nrefB} = 1695 \text{ r/min}$$

$$f_{nrefC} = 2040 \text{ r/min}$$

$$f_{nrefD} = 1212 \text{ r/min}$$

* * * * *

226. Amend § 1065.650 by revising paragraphs (a), (c)(2)(i), (3), (4)(i), and (6), (d)(7), (e)(1) and (2), (f)(1) and (2), and (g)(1) and (2) to read as follows:

§ 1065.650 Emission calculations.

(a) *General.* Calculate brake-specific emissions over each applicable duty cycle or test interval. For test intervals with zero work (or power), calculate the emission mass (or mass rate), but do not calculate brake-specific emissions. Unless specified otherwise, for the purposes of calculating and reporting emission mass (or mass rate), do not alter any negative values of measured or calculated quantities. You may truncate negative values in chemical balance quantities listed in § 1065.655(c) to facilitate convergence. For duty cycles with multiple test intervals, refer to the standard-setting part for calculations you need to determine a composite result, such as a calculation that weights and sums the results of individual test intervals in a duty

cycle. If the standard-setting part does not include those calculations, use the equations in paragraph (g) of this section. This section is written based on rectangular integration, where each indexed value (i.e., “i”) represents (or approximates) the mean value of the parameter for its respective time interval, delta-t. You may also integrate continuous signals using trapezoidal integration consistent with good engineering judgment.

* * * * *

(c) * * *

(2) * * *

(i) *Varying flow rate.* If you continuously sample from a [changing-varying](#) exhaust flow rate, time align and then multiply concentration measurements by the flow rate from which you extracted it. We consider the following to be examples of [changing-varying](#) flows that require a continuous multiplication of concentration times molar flow rate: raw exhaust, exhaust diluted with a constant flow rate of dilution air, and CVS dilution with a CVS flow meter that does not have an upstream heat exchanger or electronic flow control. This multiplication results in the flow rate of the emission itself. Integrate the emission flow rate over a test interval to determine the total emission. If the total emission is a molar quantity, convert this quantity to a mass by multiplying it by its molar mass, M . The result is the mass of the emission, m . Calculate m for continuous sampling with variable flow using the following equations:

$$m = M \cdot \sum_{i=1}^N x_i \cdot \dot{n}_i \cdot \Delta t$$

Eq. 1065.650-4

Where:

$$\Delta t = 1/f_{\text{record}} \quad \text{Eq. 1065.650-5}$$

Example:

$$M_{\text{NMHC}} = 13.875389 \text{ g/mol}$$

$$N = 1200$$

$$x_{\text{NMHC1}} = 84.5 \text{ } \mu\text{mol/mol} = 84.5 \cdot 10^{-6} \text{ mol/mol}$$

$$x_{\text{NMHC2}} = 86.0 \text{ } \mu\text{mol/mol} = 86.0 \cdot 10^{-6} \text{ mol/mol}$$

$$\dot{n}_{\text{exh1}} = 2.876 \text{ mol/s}$$

$$\dot{n}_{\text{exh2}} = 2.224 \text{ mol/s}$$

$$f_{\text{record}} = 1 \text{ Hz}$$

Using Eq. 1065.650-5,

$$\Delta t = 1/1 = 1 \text{ s}$$

$$m_{\text{NMHC}} = 13.875389 \cdot (84.5 \cdot 10^{-6} \cdot 2.876 + 86.0 \cdot 10^{-6} \cdot 2.224 + \dots + x_{\text{NMHC1200}} \cdot \dot{n}_{\text{exh}}) \cdot 1$$

$$m_{\text{NMHC}} = 25.23 \text{ g}$$

* * * * *

(3) *Batch sampling.* For batch sampling, the concentration is a single value from a proportionally extracted batch sample (such as a bag, filter, impinger, or cartridge). In this case, multiply the mean concentration of the batch sample by the total flow from which the sample was extracted. You may calculate total flow by integrating a [changing-varying](#) flow rate or by determining the mean of a constant flow rate, as follows:

(i) *Varying flow rate.* If you collect a batch sample from a [changing-varying](#) exhaust flow rate, extract a sample proportional to the [changing-varying](#) exhaust flow rate. We consider the following to be examples of [changing-varying](#) flows that require proportional sampling: raw exhaust, exhaust diluted with a constant flow rate of dilution air, and CVS dilution with a CVS flow meter that does not have an upstream heat exchanger or electronic flow control.

Integrate the flow rate over a test interval to determine the total flow from which you extracted the proportional sample. Multiply the mean concentration of the batch sample by the total flow from which the sample was extracted to determine the total emission. If the total emission is a molar quantity, convert this quantity to a mass by multiplying it by its molar mass, M . The result is the total emission mass-of-the-emission, m . In the case of PM emissions, where the mean PM concentration is already in units of mass per mole of sample exhaust, \bar{M}_{PM} , simply multiply it by the total flow. The result is the total mass of PM, m_{PM} . Calculate m for each constituent as follows:

(A) Calculate m for measuring gaseous emission constituents with batch sampling that results in a molar concentration, \bar{x} , with variable flow using the following equation:

$$m = M \cdot \bar{x} \cdot \sum_{i=1}^N \dot{n}_i \cdot \Delta t$$

Eq. 1065.650-6

Example:

$$M_{NO_x} = 46.0055 \text{ g/mol}$$

$$N = 9000$$

$$\bar{x}_{NO_x} = 85.6 \text{ } \mu\text{mol/mol} = 85.6 \cdot 10^{-6} \text{ mol/mol}$$

$$\dot{n}_{dexh1} = 25.534 \text{ mol/s}$$

$$\dot{n}_{dexh2} = 26.950 \text{ mol/s}$$

$$f_{record} = 5 \text{ Hz}$$

Using Eq. 1065.650-5:

$$\Delta t = 1/5 = 0.2$$

$$m_{NO_x} = 46.0055 \cdot 85.6 \cdot 10^{-6} \cdot (25.534 + 26.950 + \dots + \dot{n}_{exh9000}) \cdot 0.2$$

$$m_{NO_x} = 4.201 \text{ g}$$

(B) Calculate m for sampling PM or any other analysis of a batch sample that yields a mass per mole of exhaust, \bar{M} , using the following equation:

$$m = \bar{M} \cdot \sum_{i=1}^N \dot{n}_i \cdot \Delta t$$

Eq. 1065.650-7

(ii) Constant-Proportional or constant flow rate. If you batch sample from a constant exhaust flow rate, extract a sample at a proportional or constant flow rate. We consider the following to be examples of constant exhaust flows: CVS diluted exhaust with a CVS flow meter that has either an upstream heat exchanger, electronic flow control, or both. Determine the mean molar flow rate from which you extracted the constant flow rate sample. Multiply the mean concentration of the batch sample by the mean molar flow rate of the exhaust from which the sample was extracted to determine the total emission, and multiply the result by the time of the test interval. If the total emission is a molar quantity, convert this quantity to a mass by multiplying it by its molar mass, M . The result is the total emission mass-of-the-emission, m . In the case of PM emissions, where the mean PM concentration is already in units of mass per mole of sample exhaust, \bar{M}_{PM} , simply multiply it by the total flow, and the result is the total mass of PM, m_{PM} . Calculate m for each constituent as follows:

(A) Calculate m for measuring gaseous emission constituents with sampling with constant flow that results in a molar concentration, \bar{x} , using the following equation:

$$m = M \cdot \bar{x} \cdot \bar{\dot{n}} \cdot \Delta t$$

Eq. 1065.650-87

(B) Calculate m_{PM} for sampling PM or any other analysis of a batch sample that yields a mass per mole of sample exhaust, \bar{M}_e , using the following equation:

$$m_{PM} = \bar{M}_e \cdot \dot{n}_e \cdot \Delta t$$

Eq. 1065.650-98

(C) The following example illustrates a calculation of m_{PM} :

$$\bar{M}_{PM} = 144.0 \text{ } \mu\text{g/mol} = 144.0 \cdot 10^{-6} \text{ g/mol}$$

$$\dot{n}_{dexh} = 57.692 \text{ mol/s}$$

$$\Delta t = 1200 \text{ s}$$

$$m_{PM} = 144.0 \cdot 10^{-6} \cdot 57.692 \cdot 1200$$

$$m_{PM} = 9.9692 \text{ g}$$

(4) * * *

(i) For sampling with a constant dilution ratio, DR , of diluted exhaust versus exhaust flow (e.g., secondary dilution for PM sampling), calculate m using the following equation:

$$m_{PM} = m_{PMdil} \cdot DR$$

Eq. 1065.650-109

Example:

$$m_{PMdil} = 6.853 \text{ g}$$

$$DR = 6:1$$

$$m_{PM} = 6.853 \cdot 6$$

$$m_{PM} = 41.118 \text{ g}$$

* * * * *

(6) *Mass of NMNEHC.* Determine the mass of NMNEHC using one of the following methods:

(i) If the test fuel has less than 0.010 mol/mol of ethane and you omit the NMNEHC calculations as described in § 1065.660(c)(1), take the corrected mass of NMNEHC to be 0.95 times the corrected mass of NMHC.

(ii) If the test fuel has at least 0.010 mol/mol of ethane and you omit the NMNEHC calculations as described in § 1065.660(c)(1), take the corrected mass of NMNEHC to be 1.0 times the corrected mass of NMHC.

(d) * * *

(7) Integrate the resulting values for power over the test interval. Calculate total work as follows:

$$W = \sum_{i=1}^N P_i \cdot \Delta t$$

Eq. 1065.650-110

Where:

W = total work from the primary output shaft.

P_i = instantaneous power from the primary output shaft over an interval i .

$$P_i = f_{ni} \cdot T_i$$

Eq. 1065.650-121

Example:

$$N = 9000$$

$$f_{n1} = 1800.2 \text{ r/min}$$

$$f_{n2} = 1805.8 \text{ r/min}$$

$$T_1 = 177.23 \text{ N}\cdot\text{m}$$

$$T_2 = 175.00 \text{ N}\cdot\text{m}$$

$$C_{rev} = 2 \cdot \pi \text{ rad/r}$$

$$C_{t1} = 60 \text{ s/min}$$

$$C_p = 1000 \text{ (N}\cdot\text{m}\cdot\text{rad/s)/kW}$$

$$f_{\text{record}} = 5 \text{ Hz}$$

$$C_{t2} = 3600 \text{ s/hr}$$

$$P_1 = \frac{1800.2 \cdot 177.23 \cdot 2 \cdot 3.14159}{60 \cdot 1000}$$

$$P_1 = 33.41 \text{ kW}$$

$$P_2 = 33.09 \text{ kW}$$

Using Eq. 1065.650-5:

$$\Delta t = 1/5 = 0.2 \text{ s}$$

$$W = \frac{(33.41 + 33.09 + \dots + P_{9000}) \cdot 0.2}{3600}$$

$$W = 16.875 \text{ kW}\cdot\text{hr}$$

* * * * *

(e) * * *

(1) To calculate, \bar{m} , multiply its mean concentration, \bar{x} , by its corresponding mean molar flow rate, \bar{n} . If the result is a molar flow rate, convert this quantity to a mass rate by multiplying it by its molar mass, M . The result is the mean mass rate of the emission, \bar{m} . In the case of PM emissions, where the mean PM concentration is already in units of mass per mole of ~~sample exhaust, \bar{M}_{PM}~~ , simply multiply it by the mean molar flow rate, \bar{n} . The result is the mass rate of PM, \bar{m}_{PM} . Calculate \bar{m} using the following equation:

$$\bar{m} = M \cdot \bar{x} \cdot \bar{n}$$

Eq. 1065.650-13~~2~~

(2) To calculate an engine's mean steady-state total power, \bar{P} , add the mean steady-state power from all the work paths described in § 1065.210 that cross the system boundary including electrical power, mechanical shaft power, and fluid pumping power. For all work paths, except the engine's primary output shaft (crankshaft), the mean steady-state power over the test interval is the integration of the net work flow rate (power) out of the system boundary divided by the period of the test interval. When power flows into the system boundary, the power/work flow rate signal becomes negative; in this case, include these negative power/work rate values in the integration to calculate the mean power from that work path. Some work paths may result in a negative mean power. Include negative mean power values from any work path in the mean total power from the engine rather than setting these values to zero. The rest of this paragraph (e)(2) describes how to calculate the mean power from the engine's primary output shaft.

Calculate \bar{P} using Eq. 1065.650-13, noting that \bar{P} , \bar{f}_n , and \bar{T} refer to mean power, mean rotational shaft frequency, and mean torque from the primary output shaft. Account for the power of simulated accessories according to § 1065.110 (reducing the mean primary output shaft power or torque by the accessory power or torque). Set the power to zero during actual motoring operation (negative feedback torques), unless the engine was connected to one or more energy storage devices. Examples of such energy storage devices include hybrid powertrain batteries and hydraulic accumulators, like the ones illustrated in Figure 1 of § 1065.210. Set the power to zero for modes with a zero reference load (0 N·m reference torque or 0 kW reference power). Include power during idle modes with simulated minimum torque or power.

$$\bar{P} = \bar{f}_n \cdot \bar{T}$$

Eq. 1065.650-14~~3~~

* * * * *

(f) * * *

(1) *Total mass.* To determine a value proportional to the total mass of an emission, determine total mass as described in paragraph (c) of this section, except substitute for the molar flow rate,

\dot{n} , or the total flow, n , with a signal that is linearly proportional to molar flow rate, \tilde{n} , or linearly proportional to total flow, \tilde{n} , as follows:

$$\tilde{m}_{\text{fuel}i} = \frac{1}{w_{\text{fuel}}} \cdot \frac{M_C \cdot \tilde{n}_i \cdot x_{\text{Ccombdry}i}}{1 + x_{\text{H}_2\text{Oexhdry}i}}$$

Eq. 1065.650-154

(2) *Total work.* To calculate a value proportional to total work over a test interval, integrate a value that is proportional to power. Use information about the brake-specific fuel consumption of your engine, e_{fuel} , to convert a signal proportional to fuel flow rate to a signal proportional to power. To determine a signal proportional to fuel flow rate, divide a signal that is proportional to the mass rate of carbon products by the fraction of carbon in your fuel, w_C . You may use a measured w_C or you may use default values for a given fuel as described in § 1065.655(e). Calculate the mass rate of carbon from the amount of carbon and water in the exhaust, which you determine with a chemical balance of fuel, DEF, intake air, and exhaust as described in § 1065.655. In the chemical balance, you must use concentrations from the flow that generated the signal proportional to molar flow rate, \tilde{n} , in paragraph (e)(1) of this section. Calculate a value proportional to total work as follows:

$$W = \sum_{i=1}^N \tilde{P}_i \cdot \Delta t$$

Eq. 1065.650-165

Where:

$$\tilde{P}_i = \frac{\tilde{m}_{\text{fuel}i}}{e_{\text{fuel}}}$$

Eq. 1065.650-176

* * * * *

(g) * * *

(1) Use the following equation to calculate composite brake-specific emissions for duty cycles with multiple test intervals all with prescribed durations, such as cold-start and hot-start transient cycles:

$$e_{\text{comp}} = \frac{\sum_{i=1}^N WF_i \cdot m_i}{\sum_{i=1}^N WF_i \cdot W_i}$$

Eq. 1065.650-187

Where:

i = test interval number.

N = number of test intervals.

WF = weighting factor for the test interval as defined in the standard-setting part.

m = mass of emissions over the test interval as determined in paragraph (c) of this section.

W = total work from the engine over the test interval as determined in paragraph (d) of this section.

Example:

$N = 2$

$WF_1 = 0.1428$

$WF_2 = 0.8572$

$m_1 = 70.125 \text{ g}$

$m_2 = 64.975 \text{ g}$

$W_1 = 25.783 \text{ kW}\cdot\text{hr}$

$$W_2 = 25.783 \text{ kW}\cdot\text{hr}$$

$$e_{\text{NO}_x\text{comp}} = \frac{(0.1428 \cdot 70.125) + (0.8572 \cdot 64.975)}{(0.1428 \cdot 25.783) + (0.8572 \cdot 25.783)}$$

$$e_{\text{NO}_x\text{comp}} = 2.548 \text{ g/kW}\cdot\text{hr}$$

(2) Calculate composite brake-specific emissions for duty cycles with multiple test intervals that allow use of varying duration, such as discrete-mode steady-state duty cycles, as follows:

(i) Use the following equation if you calculate brake-specific emissions over test intervals based on total mass and total work as described in paragraph (b)(1) of this section:

$$e_{\text{comp}} = \frac{\sum_{i=1}^N WF_i \cdot \frac{m_i}{t_i}}{\sum_{i=1}^N WF_i \cdot \frac{W_i}{t_i}}$$

Eq. 1065.650-198

Where:

i = test interval number.

N = number of test intervals.

WF = weighting factor for the test interval as defined in the standard-setting part.

m = mass of emissions over the test interval as determined in paragraph (c) of this section.

W = total work from the engine over the test interval as determined in paragraph (d) of this section.

t = duration of the test interval.

Example:

$$N = 2$$

$$WF_1 = 0.85$$

$$WF_2 = 0.15$$

$$m_1 = 1.3753 \text{ g}$$

$$m_2 = 0.4135 \text{ g}$$

$$t_1 = 120 \text{ s}$$

$$t_2 = 200 \text{ s}$$

$$W_1 = 2.8375 \text{ kW}\cdot\text{hr}$$

$$W_2 = 0.0 \text{ kW}\cdot\text{hr}$$

$$e_{\text{NO}_x\text{comp}} = \frac{\left(0.85 \cdot \frac{1.3753}{120}\right) + \left(0.15 \cdot \frac{0.4135}{200}\right)}{\left(0.85 \cdot \frac{2.8375}{120}\right) + \left(0.15 \cdot \frac{0.0}{200}\right)}$$

$$e_{\text{NO}_x\text{comp}} = 0.5001 \text{ g/kW}\cdot\text{hr}$$

(ii) Use the following equation if you calculate brake-specific emissions over test intervals based on the ratio of mass rate to power as described in paragraph (b)(2) of this section:

$$e_{\text{comp}} = \frac{\sum_{i=1}^N WF_i \cdot \dot{m}_i}{\sum_{i=1}^N WF_i \cdot \dot{P}_i}$$

Eq. 1065.650-2019

Where:

i = test interval number.

N = number of test intervals.

WF = weighting factor for the test interval as defined in the standard-setting part.

\bar{m} = mean steady-state mass rate of emissions over the test interval as determined in paragraph (e) of this section.

\bar{P} = mean steady-state power over the test interval as described in paragraph (e) of this section.

Example:

$N = 2$

$WF_1 = 0.85$

$WF_2 = 0.15$

$\bar{m}_1 = 2.25842 \text{ g/hr}$

$\bar{m}_2 = 0.063443 \text{ g/hr}$

$\bar{P}_1 = 4.5383 \text{ kW}$

$\bar{P}_2 = 0.0 \text{ kW}$

$$e_{\text{NO}_x \text{comp}} = \frac{(0.85 \cdot 2.25842) + (0.15 \cdot 0.063443)}{(0.85 \cdot 4.5383) + (0.15 \cdot 0.0)}$$

$$e_{\text{NO}_x \text{comp}} = 0.5001 \text{ g/kW}\cdot\text{hr}$$

* * * * *

227. Amend § 1065.655 by revising paragraph (e)(1)(i) to read as follows:

§ 1065.655 Chemical balances of fuel, DEF, intake air, and exhaust.

* * * * *

(e) * * *

(1) * * *

(i) Determine the carbon and hydrogen mass fractions according to ASTM D5291 (incorporated by reference in § 1065.1010). When using ASTM D5291 to determine carbon and hydrogen mass fractions of gasoline (with or without blended ethanol), use good engineering judgment to adapt the method as appropriate. This may include consulting with the instrument manufacturer on how to test high-volatility fuels. Allow the weight of volatile fuel samples to stabilize for 20 minutes before starting the analysis; if the weight still drifts after 20 minutes, prepare a new sample). Retest the sample if the carbon, hydrogen, oxygen, sulfur, and nitrogen mass fractions do not add up to a total mass of $100 \pm 0.5 \%$; ~~if you do not measure oxygen,~~ you may assume it oxygen has a zero ~~concentration-mass contribution~~ for diesel fuel and neat (E0) gasoline. You may also assume that sulfur and nitrogen have a zero ~~concentration-mass contribution for this specification~~ for all fuels except residual fuel blends.

* * * * *

228. Amend § 1065.660 by revising paragraph (c)(1) to read as follows:

§ 1065.660 THC, NMHC, NMNEHC, CH₄, and C₂H₆ determination.

* * * * *

(c) * * *

(1) Calculate x_{NMNEHC} based on the test fuel's ethane content as follows:

(i) If the content of your test fuel contains less than 0.010 mol/mol of ethane, you may omit the calculation of NMNEHC concentrations and calculate the mass of NMNEHC as described in § 1065.650(c)(6)(i).

(ii) If the content of your fuel test contains at least 0.010 mol/mol of ethane, you may omit the calculation of NMNEHC concentration and calculate the mass of NMNEHC as described in § 1065.650(c)(6)(ii).

* * * * *

229. Amend § 1065.667 by revising paragraph (a) to read as follows:

§ 1065.667 Dilution air background emission correction.

(a) To determine the mass of background emissions to subtract from a diluted exhaust sample, first determine the total flow of dilution air, n_{dil} , over the test interval. This may be a measured quantity or a calculated quantity. Multiply the total flow of dilution air by the mean mole fraction (i.e., concentration) of a background emission. This may be a time-weighted mean or a flow-weighted mean (e.g., a proportionally sampled background). Finally, multiply by the molar mass, M , of the associated gaseous emission constituent. The product of n_{dil} and the mean molar concentration of a background emission and its molar mass, M , is the total background emission mass, m . In the case of PM, where the mean PM concentration is already in units of mass per mole of ~~sample exhaust~~, \bar{M}_{PM} , multiply it by the total amount of dilution air flow, and the result is the total background mass of PM, m_{PM} . Subtract total background mass from total mass to correct for background emissions.

* * * * *

230. Amend § 1065.672 by revising paragraphs (d)(3) and (4) to read as follows:

§ 1065.672 Drift correction.

* * * * *

(d) * * *

(3) For any pre-test interval concentrations, use the last concentrations determined ~~most recently~~ before the test interval. For some test intervals, the ~~most recent~~last pre-zero or pre-span might have occurred before one or more ~~previous~~earlier test intervals.

(4) For any post-test interval concentrations, use the first concentrations determined ~~most recently~~ after the test interval. For some test intervals, the ~~most recent~~first post-zero or post-span might ~~have occurred~~ after one or more ~~subsequent~~later test intervals.

* * * * *

231. Amend § 1065.680 by revising the introductory text to read as follows:

§ 1065.680 Adjusting emission levels to account for infrequently regenerating aftertreatment devices.

This section describes how to calculate and apply emission adjustment factors for engines using aftertreatment technology with infrequent regeneration events that may occur during testing. These adjustment factors are typically calculated based on measurements conducted for the purposes of engine certification, and then used to adjust the results of testing related to demonstrating compliance with emission standards. For this section, “regeneration” means an intended event during which emission levels change while the system restores aftertreatment performance. For example, exhaust gas temperatures may increase temporarily to remove sulfur from an adsorbers or SCR catalyst or to oxidize accumulated particulate matter in a trap. The duration of this event extends until the aftertreatment performance and emission levels have returned to normal baseline levels. Also, “infrequent” refers to regeneration events that are expected to occur on average less than once over a transient or ramped-modal duty cycle, or on average less than once per mode in a discrete-mode test.

* * * * *

232. Amend § 1065.695 by revising paragraph (a) to read as follows:

§ 1065.695 Data requirements.

(a) To determine the information we require from engine tests, refer to the standard-setting part and request from your ~~Designated Compliance~~ EPA Program Officer the format used to apply for certification or demonstrate compliance. We may require different information for different purposes, such as for certification applications, approval requests for alternate procedures, selective enforcement audits, laboratory audits, production-line test reports, and field-test reports.

* * * * *

233. Amend § 1065.715 by revising paragraph (b)(3) to read as follows:

§ 1065.715 Natural gas.

* * * * *

(b) * * *

(3) You may ask for approval to use fuel that does not meet the specifications in paragraph (a) of this section, but only if using the fuel would not adversely affect your ability to demonstrate compliance with the applicable standards in this chapter.

* * * * *

234. Amend § 1065.720 by revising paragraphs (a) and (b)(3) to read as follows:

§ 1065.720 Data requirements.

(a) Except as specified in paragraph (b) of this section, liquefied petroleum gas for testing must meet the specifications in the following table:

Table 1 of § 1065.720(a)–Test Fuel Specifications for Liquefied Petroleum Gas

Property	Value	Reference Procedure ^a
Propane, C ₃ H ₈	Minimum, 0.85 m ³ /m ³	ASTM D2163.
Vapor pressure at 38 °C	Maximum, 1400 kPa	ASTM D1267 or ASTM D2598 ^b .
Volatility residue (evaporated temperature, 35 °C)	Maximum, 38 °C	ASTM D1837
Butanes	Maximum, 0.05 m ³ /m ³	ASTM D2163.
Butenes	Maximum, 0.02 m ³ /m ³	ASTM D2163.
Pentenes and heavier	Maximum, 0.005 m ³ /m ³	ASTM D2163.
Propene	Maximum, 0.1 m ³ /m ³	ASTM D2163.
Residual matter (residue on evaporation of 100 ml oil stain observation)	Maximum, 0.05 ml pass ^c	ASTM D2158.
Corrosion, copper strip	Maximum, No. 1	ASTM D1838.
Sulfur	Maximum, 80 mg/kg	ASTM D6667.
Moisture content	pass	ASTM D2713.

^aIncorporated by reference; see § 1065.1010. See § 1065.701(d) for other allowed procedures.

^bIf these two test methods yield different results, use the results from ASTM D1267.

^cThe test fuel must not yield a persistent oil ring when you add 0.3 ml of solvent residue mixture to a filter paper in 0.1 ml increments and examine it in daylight after two minutes.

(b) * * *

(3) You may ask for approval to use fuel that does not meet the specifications in paragraph (a) of this section, but only if using the fuel would not adversely affect your ability to demonstrate compliance with the applicable standards in this chapter.

* * * * *

235. Revise § 1065.790 to read as follows:

§ 1065.790 Mass standards.

- (a) *PM balance calibration weights.* Use PM balance calibration weights that are certified as NIST-traceable within ± 0.1 % uncertainty. ~~Calibration weights may be certified by any calibration lab that maintains NIST traceability.~~ Make sure your highest calibration weight has no ~~more~~ greater than ten times the mass of an unused PM-sample medium.
- (b) *Dynamometer, fuel mass scale, and DEF mass scale calibration weights.* Use dynamometer and mass scale calibration weights that are certified as NIST-traceable within ± 0.1 % uncertainty.

236. Amend § 1065.901 by revising paragraphs (a) and (b)(3) to read as follows:

§ 1065.901 Applicability.

- (a) *Field testing.* This subpart specifies procedures for field-testing engines to determine brake-specific emissions and mass rate emissions using portable emission measurement systems (PEMS). These procedures are designed primarily for in-field measurements of engines that remain installed in vehicles or equipment the field. Field-test procedures apply to your engines only as specified in the standard-setting part.
- (b) * * *
- (3) Do not use PEMS for laboratory measurements if it prevents you from demonstrating compliance with the applicable standards in this chapter. Some of the PEMS requirements in this part 1065 are less stringent than the corresponding laboratory requirements. Depending on actual PEMS performance, you might therefore need to account for some additional measurement uncertainty when using PEMS for laboratory testing. If we ask, you must show us by engineering analysis that any additional measurement uncertainty due to your use of PEMS for laboratory testing is offset by the extent to which your engine's emissions are below the applicable standards in this chapter. For example, you might show that PEMS versus laboratory uncertainty represents 5 % of the standard, but your engine's deteriorated emissions are at least 20 % below the standard for each pollutant.

237. Amend § 1065.910 by revising paragraphs (b) and (d)(2) to read as follows:

§ 1065.910 PEMS auxiliary equipment for field testing.

* * * * *

- (b) ~~For vehicles or other motive equipment, we recommend installing PEMS in the same location where a passenger might sit. Follow PEMS manufacturer instructions for installing PEMS in cargo spaces, engine spaces, or externally such that PEMS is directly exposed to the outside environment. We recommend locate theing PEMS where it will be subject to minimal sourcesto minimize the effects~~ of the following parameters or place the PEMS in an environmental enclosure that minimizes the effect of these parameters on the emission measurement:

- (1) Ambient temperature changes.
- ~~(2) Ambient pressure changes.~~
- ~~(2)3~~ (2)3) Electromagnetic radiation.
- ~~(3)4~~ (3)4) Mechanical shock and vibration.
- ~~(5) Ambient hydrocarbons if using a FID analyzer that uses ambient air as FID burner ai~~

* * * * *

- (d) * * *

(2) You may install your own portable power supply. For example, you may use batteries, fuel cells, a portable generator, or any other power supply to supplement or replace your use of vehicle power. You may connect an external power source directly to the vehicle's, vessel's, or equipment's power system; however, ~~during a test interval (such as an NTE event)~~ you must not supply power to the vehicle's power system in excess of 1 % of the engine's maximum power.

238. Amend § 1065.915 by revising paragraph (d)(6) to read as follows:

§ 1065.915 PEMS instruments.

* * * * *

(d) * * *

(6) *Permissible deviations.* ECM signals may deviate from the specifications of this part 1065, but the expected deviation must not prevent you from demonstrating that you meet the applicable standards **in this chapter**. For example, your emission results may be sufficiently below an applicable standard, such that the deviation would not significantly change the result. As another example, a very low engine-coolant temperature may define a logical statement that determines when a test interval may start. In this case, even if the ECM's sensor for detecting coolant temperature was not very accurate or repeatable, its output would never deviate so far as to significantly affect when a test interval may start.

239. Amend § 1065.920 by:

- a. Revising paragraphs (b)(2), (b)(4) introductory text, and (b)(4)(iii).
- b. Removing paragraph (b)(5).
- c. Redesignating paragraphs (b)(6) and (7) as (b)(5) and (6), respectively.
- d. Revising the redesignated paragraph (b)(6)(ii).

The revisions read as follows:

§ 1065.920 PEMS calibrations and verifications.

* * * * *

(b) * * *

(2) Select or create a duty cycle that has all the following characteristics:

(i) Engine operation that represents normal in-use speeds, loads, and degree of transient activity. Consider using data from previous field tests to generate a cycle.

(ii) A duration of ~~(20-6 to 409)~~ **minhours**.

~~(iii) At least 50 % of engine operating time must include at least 10 valid test intervals for calculating emission levels for field testing. For example, for highway compression-ignition engines, select a duty cycle in which at least 50 % of the engine operating time can be used to calculate valid NTE events.~~

* * * * *

(4) Determine the brake-specific **emissions and mass rate** emissions, **as applicable**, for each test interval for both laboratory and the PEMS measurements, as follows:

* * * * *

(iii) If the standard-setting part specifies the use of a measurement allowance for field testing, also apply the measurement allowance during calibration using good engineering judgment. If the measurement allowance is normally added to the standard, this means you must subtract the measurement allowance from ~~the~~ measured PEMS **brake-specific** emission results.

* * * * *

~~(67)~~ * * *

(ii) The entire set of test-interval results passes the 95 % confidence alternate-procedure statistics for field testing (*t*-test and *F*-test) specified in § 1065.12~~subpart A of this part.~~

240. Amend § 1065.935 by revising paragraphs (d)(4) and (g) to read as follows:

§ 1065.935 Emission test sequence for field testing.

* * * * *

(d) * * *

(4) Conduct periodic verifications such as zero and span verifications on PEMS gas analyzers and use these to correct for drift according to paragraph (g) of this section. Do not include data recorded during verifications in emission calculations. Conduct the verifications as follows:

(i) For PEMS gas analyzers used to determine NTE emission values, perform verifications; as recommended by the PEMS manufacturer or as indicated by good engineering judgment. ~~Results from these verifications will be used to calculate and correct for drift according to paragraph (g) of this section. Do not include data recorded during verifications in emission calculations.~~

(ii) For PEMS gas analyzers used to determine bin emission values, perform zero verifications at least hourly using purified air. Perform span verification at the end of the shift-day or more frequently as recommended by the PEMS manufacturer or as indicated by good engineering judgment.

* * * * *

(g) Take the following steps after emission sampling is complete:

(1) As soon as practical after ~~the~~ emission sampling, analyze any gaseous batch samples.

(2) If you used dilution air, either analyze background samples or assume that background emissions were zero. Refer to § 1065.140 for dilution-air specifications.

(3) After quantifying all exhaust gases, record mean analyzer values after stabilizing a zero gas to each analyzer, then record mean analyzer values after stabilizing the span gas to the analyzer. Stabilization may include time to purge an analyzer of any sample gas and, plus any additional time to account for analyzer response. Use these recorded values, including pre-test verifications and any zero verifications during testing, to correct for drift as described in § 1065.550.

(4) Verify PEMS gas analyzers used to determine NTE emission values as follows:

(i) Invalidate any ~~test intervals~~data that does not meet the range criteria in § 1065.550. Note that it is acceptable that analyzers exceed 100 % of their ranges when measuring emissions between test intervals, but not during test intervals. You do not have to retest an engine ~~in the field~~ if the range criteria are not met.

(ii) Invalidate any data that does not meet the drift criterion in § 1065.550. For HC, invalidate any data if the difference between the uncorrected and the corrected brake-specific HC emission values are within ±10 % of the uncorrected results or the applicable standard, whichever is greater. For data that does meet the drift criterion, correct those test intervals for drift according to § 1065.672 and use the drift corrected results in emissions calculations.

(5) Verify PEMS gas analyzers used to determine bin emission values as follows:

(i) Invalidate data from a whole shift-day if more than 1 % of recorded 1 Hz data exceeds 100 % of the selected gas analyzer range. For analyzer outputs exceeding 100 % of range, calculate emission results using the reported value. You must retest an engine if the range criteria are not met.

(ii) Invalidate any ~~data for periods in which the CO, CO₂, and HC gas analyzers test intervals that~~ do not meet the drift criterion in § 1065.550. For NMHC, invalidate any

test intervals data if the difference between the uncorrected and the corrected brake-specific NMHC emission values are within $\pm 10\%$ of the uncorrected results or the applicable standard, whichever is greater. For test intervals data that do meet the drift criterion, correct those test intervals that data for drift according to § 1065.672 and use the drift corrected results in emissions calculations.

(iii) For PEMS NO_x analyzers used to determine bin emission values, use the following drift limits to verify drift instead of meeting the drift criteria specified in § 1065.550:

(A) The allowable analyzer zero-drift between successive zero verifications is ± 2.5 ppm. The analyzer zero-drift limit over the shift-day is ± 10 ppm.

(B) The allowable analyzer span-drift limit is $\pm 4\%$ of the measured span value between successive span verifications.

(6) Unless you weighed PM in-situ, such as by using an inertial PM balance, place any used PM samples into covered or sealed containers and return them to the PM-stabilization environment and weigh them as described in § 1065.595.

241. Amend § 1065.1001 by:

- a. Removing the definition for “Designated Compliance Officer”.
- b. Adding definitions for “Dual-fuel”, “EPA Program Officer”, and “Flexible-fuel” in alphabetical order.
- c. Removing the definition for “Intermediate test speed”.
- d. Adding a definition for Intermediate speed in alphabetical order.
- e. Revising the definition for “NIST-traceable”.
- f. Adding definitions for “No-load” and “Rechargeable Energy Storage System (RESS)” in alphabetical order.
- g. Revising the definition for “Steady-state”.

The additions and revisions read as follows:

§ 1065.1001 Definitions.

* * * * *

Dual-fuel has the meaning given in the standard-setting part.

* * * * *

EPA Program Officer means the Director, Compliance Division, U.S. Environmental Protection Agency, 2000 Traverwood Dr., Ann Arbor, MI 48105.

* * * * *

Flexible-fuel has the meaning given in the standard-setting part.

* * * * *

Intermediate ~~test~~ speed has the meaning given in § 1065.610.

* * * * *

NIST-traceable means relating to a standard value that can be related to NIST-stated references through an unbroken chain of comparisons, all having stated uncertainties, as specified in NIST Technical Note 1297 (incorporated by reference in § 1065.1010). Allowable uncertainty limits specified for NIST-traceability refer to the propagated uncertainty specified by NIST. ~~You may ask to use other internationally recognized standards that are equivalent to NIST standards.~~

* * * * *

No-load means a dynamometer setting of zero torque.

* * * * *

Rechargeable Energy Storage System (RESS) means the components of a hybrid engine or vehicle that store recovered energy for later use, such as the battery system in a hybrid electric vehicle.

* * * * *

Steady-state means relating to emission tests in which engine speed and load are held at a finite set of nominally constant values. Steady-state tests are generally either discrete-mode tests or ramped-modal tests.

* * * * *

242. Amend § 1065.1005 by adding a row in Table 1 of paragraph (a) for “κ” in alphanumeric order and revising paragraphs (b), and (f)(1), (3), and (4) to read as follows:

§ 1065.1005 Symbols, abbreviations, acronyms, and units of measure.

* * * * *

(a) * * *

Table 1 of § 1065.1005—Symbols for Quantities

SYMBOL	QUANTITY	UNIT	UNIT SYMBOL	UNITS IN TERMS OF SI BASE UNITS
* * * * *				
<u>κ</u>	<u>opacity</u>			
* * * * *				

* * * * *

(b) *Symbols for chemical species.* This part uses the following symbols for chemical species and exhaust constituents:

Table 2 of §1065.1005—Symbols for Chemical Species and Exhaust Constituents

Symbol	Species
Ar	argon.
C	carbon.
CH ₂ O	formaldehyde.
CH ₂ O ₂	formic acid.
CH ₃ OH	methanol.
CH ₄	methane.
C ₂ H ₄ O	acetaldehyde.
C ₂ H ₅ OH	ethanol.
C ₂ H ₆	ethane.
C ₃ H ₇ OH	propanol.
C ₃ H ₈	propane.
C ₄ H ₁₀	butane.
C ₅ H ₁₂	pentane.
CO	carbon monoxide.
CO ₂	carbon dioxide.
H	atomic hydrogen.
H ₂	molecular hydrogen.
H ₂ O	water.
H ₂ SO ₄	sulfuric acid.
HC	hydrocarbon.
He	helium.
⁸⁵ Kr	krypton 85.
N ₂	molecular nitrogen.
NH ₃	ammonia.
NMHC	nonmethane hydrocarbon.
NMHCE	nonmethane hydrocarbon equivalent.
NMNEHC	nonmethane-nonethane hydrocarbon.
NO	nitric oxide.
NO ₂	nitrogen dioxide.
NO _x	oxides of nitrogen.
N ₂ O	nitrous oxide.

NMOG	nonmethane organic gases.
NONMHC	non-oxygenated nonmethane hydrocarbon.
NOTHC	non-oxygenated total hydrocarbon.
O ₂	molecular oxygen.
OHC	oxygenated hydrocarbon.
²¹⁰ Po	polonium 210.
PM	particulate matter.
S	sulfur.
SVOC	semi-volatile organic compound.
THC	total hydrocarbon.
THCE	total hydrocarbon equivalent.
ZrO ₂	zirconium dioxide.

* * * * *

(f) * * *

(1) This part uses the following constants for the composition of dry air:

Table 6 of §1065.1005—Constants

Symbol	Quantity	mol/mol
$x_{Ar_{air}}$	amount of argon in dry air	0.00934
$x_{CO2_{air}}$	amount of carbon dioxide in dry air	0.000375
$x_{N2_{air}}$	amount of nitrogen in dry air	0.78084
$x_{O2_{air}}$	amount of oxygen in dry air	0.209445

* * * * *

(3) This part uses the following molar gas constant for ideal gases:

Table 8 of §1065.1005—Molar Gas Constant for Ideal Gases

Symbol	Quantity	$\frac{J}{(mol \cdot K)}$ $(m^2 \cdot kg \cdot s^{-2} \cdot mol^{-1} \cdot K^{-1})$
R	molar gas constant	8.314472

(4) This part uses the following ratios of specific heats for dilution air and diluted exhaust:

Table 9 of §1065.1005—Ratios of Specific Heats for Dilution Air and Diluted Exhaust

Symbol	Quantity	$[\frac{J}{(kg \cdot K)}] / [\frac{J}{(kg \cdot K)}]$
γ_{air}	ratio of specific heats for intake air or dilution air	1.399
γ_{dil}	ratio of specific heats for diluted exhaust	1.399
γ_{exh}	ratio of specific heats for raw exhaust	1.385

* * * * *

243. Amend subpart L by adding a new center header “VANADIUM SUBLIMATION IN SCR CATALYSTS” after § 1065.1111 and adding §§ 1065.1113, 1065.1115, 1065.1117, 1065.1119, and 1065.1121 under the new center header to read as follows:

VANADIUM SUBLIMATION IN SCR CATALYSTS

§ 1065.1113 General provisions related to vanadium sublimation temperatures in SCR catalysts.

This section and §§ 1065.1115 through 1065.1121 specify procedures for determining vanadium emissions from a catalyst based on catalyst temperature. Vanadium can be emitted from the surface of SCR catalysts at temperatures above 550 °C, dependent on the catalyst formulation. These procedures are appropriate for measuring the vanadium sublimation product from a reactor by sampling onto an equivalent mass of alumina and performing analysis by Inductively Coupled

Plasma – Optical Emission Spectroscopy (ICP-OES). Follow standard analytic chemistry methods for any aspects of the analysis that are not specified.

(a) The procedure is adapted from “Behavior of Titania-supported Vanadia and Tungsta SCR Catalysts at High Temperatures in Reactant Streams: Tungsten and Vanadium Oxide and Hydroxide Vapor Pressure Reduction by Surficial Stabilization” (Chapman, D.M., Applied Catalysis A: General, 2011, 392, 143-150) with modifications to the acid digestion method from “Measuring the trace elemental composition of size-resolved airborne particles” (Herner, J.D. *et al*, Environmental Science and Technology, 2006, 40, 1925–1933).

(b) Laboratory cleanliness is especially important throughout vanadium testing. Thoroughly clean all sampling system components and glassware before testing to avoid sample contamination.

§ 1065.1115 Reactor design and setup.

Vanadium measurements rely on a reactor that adsorbs sublimation vapors of vanadium onto an alumina capture bed with high surface area.

(a) Configure the reactor with the alumina capture bed downstream of the catalyst in the reactor’s hot zone to adsorb vanadium vapors at high temperature. You may use quartz beads upstream of the catalyst to help stabilize reactor gas temperatures. Select an alumina material and design the reactor to minimize sintering of the alumina. For a 1-inch diameter reactor, use 4 to 5 g of 1/8 inch extrudates or -14/+24 mesh (approximately 0.7 to 1.4 mm) gamma alumina (such as Alfa Aesar, aluminum oxide, gamma, catalyst support, high surface area, bimodal). Position the alumina downstream from either an equivalent amount of -14/+24 mesh catalyst sample or an approximately 1-inch diameter by 1 to 3-inch long catalyst-coated monolith sample cored from the production-intent vanadium catalyst substrate. Separate the alumina from the catalyst with a 0.2 to 0.4 g plug of quartz wool. Place a short 4 g plug of quartz wool downstream of the alumina to maintain the position of that bed. Use good engineering judgment to adjust as appropriate for reactors of different sizes.

(b) Include the quartz wool with the capture bed to measure vanadium content. We recommend analyzing the downstream quartz wool separately from the alumina to see if the alumina fails to capture some residual vanadium.

(c) Configure the reactor such that both the sample and capture beds are in the reactor’s hot zone. Design the reactor to maintain similar temperatures in the capture bed and catalyst. Monitor the catalyst and alumina temperatures with Type K thermocouples inserted into a thermocouple well that is in contact with the catalyst sample bed.

(d) If there is a risk that the quartz wool and capture bed are not able to collect all the vanadium, configure the reactor with an additional capture bed and quartz wool plug just outside the hot zone and analyze the additional capture bed and quartz wool separately.

(e) Examples of the catalyst-coated monolith and capture bed arrangement in the reactor tube are shown in the following figure:

Figure 1 of § 1065.1115– Example of reactor setup

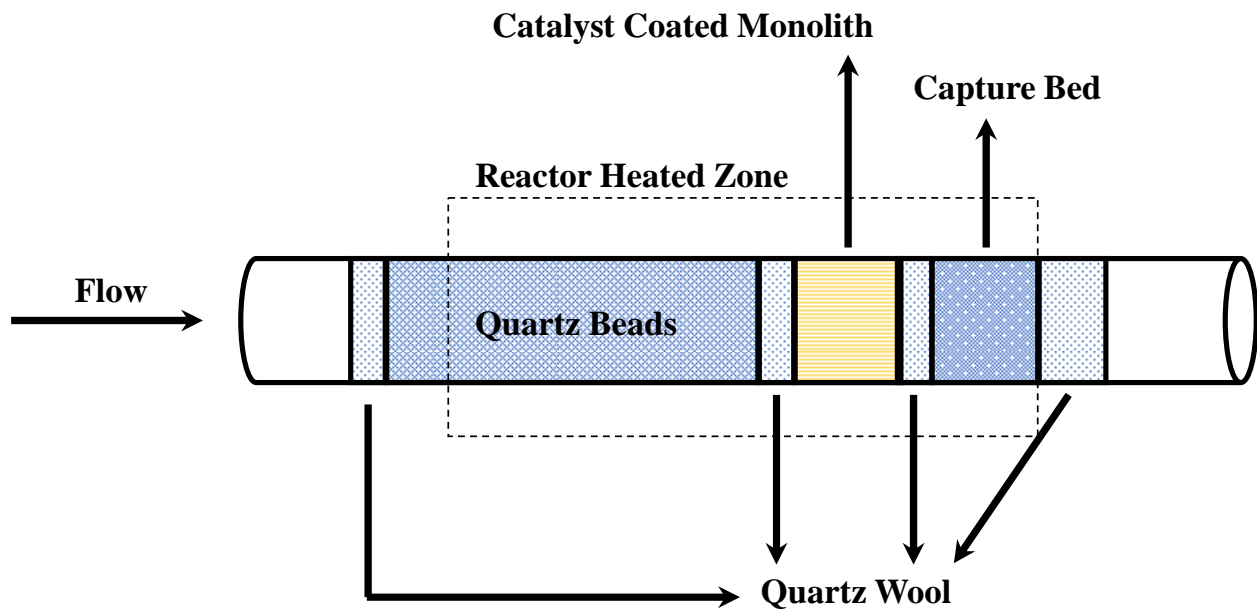

(f) You may need to account for vanadium-loaded particles contaminating catalyst-coated monoliths as a result of physical abrasion. To do this, determine how much titanium is in the capture bed and compare to an alumina blank. Using these values and available information about the ratio of vanadium to titanium in the catalyst, subtract the mass of vanadium catalyst material associated with the catalyst particles from the total measured vanadium on the capture bed to determine the vanadium recovered due to sublimation.

§ 1065.1117 Reactor aging cycle for determination of vanadium sublimation temperature.

This section describes the conditions and process required to operate the reactor described in § 1065.1115 for collection of the vanadium sublimation samples for determination of vanadium sublimation temperature. The reactor aging cycle constitutes the process of testing the catalyst sample over all the test conditions described in paragraph (b) of this section.

(a) Set up the reactor to flow gases with a space velocity of at least 35,000/hr with a pressure drop across the catalyst and capture beds less than 35 kPa. Use test gases meeting the following specifications, noting that not all gases will be used at the same time:

- (1) 5 vol% O₂, balance N₂.
- (2) NO, balance N₂. Use an NO concentration of (200 to 500) ppm.
- (3) NH₃, balance N₂. Use an NH₃ concentration of (200 to 500) ppm.

(b) Perform testing as follows:

- (1) Add a new catalyst sample and capture bed into the reactor as described in § 1065.1113. Heat the reactor to 550 °C while flowing the oxygen blend specified in paragraph (a)(1) of this section as a pretest gas mixture. Ensure that no H₂O is added to the pretest gas mixture to reduce the risk of sintering and vanadium sublimation.
- (2) Start testing at a temperature that is lower than the point at which vanadium starts to sublime. Start testing when the reactor reaches 550 °C unless testing supports a lower starting temperature. Once the reactor reaches the starting temperature and the catalyst has been equilibrated to the reactor temperature, flow NO, and NH₃ test gases for 18 hours with a nominal H₂O content of 5 volume percent.
- (3) After 18 hours of exposure, flow the pretest oxygen blend as specified in paragraph (b)(1) of this section and allow the reactor to cool down to room temperature.

(4) Analyze the sample as described in § 1065.1121.

(5) Repeat the testing in paragraphs (b)(1) through (4) of this section by raising the reactor temperature in increments of 50 °C up to the temperature at which vanadium sublimation begins. (6) Once sublimation has been detected, repeat the testing in paragraphs (b)(1) through (4) of this section by decreasing the reactor temperature in increments of 25 °C until the vanadium concentration falls below the sublimation threshold.

(7) Repeat the testing in paragraphs (b)(1) through (6) of this section with a nominal H₂O concentration of 10 volume percent or the maximum water concentration expected at the standard.

(8) You may optionally test in a manner other than testing a single catalyst formulation in series across all test temperatures. For example, you may test additional samples at the same reactor temperature before moving on to the next temperature.

(c) The effective sublimation temperature for the tested catalyst is the lowest reactor temperature determined in paragraph (b) of this section below which vanadium emissions are less than the method detection limit.

§ 1065.1119 Blank testing.

This section describes the process for analyzing blanks. Use blanks to determine the background effects and the potential for contamination from the sampling process.

(a) Take blanks from the same batch of alumina used for the capture bed.

(b) Media blanks are used to determine if there is any contamination in the sample media. Analyze at least one media blank for each reactor aging cycle or round of testing performed under § 1065.1117. If your sample media is taken from the same lot, you may analyze media blanks less frequently consistent with good engineering judgment.

(c) Field blanks are used to determine if there is any contamination from environmental exposure of the sample media. Analyze at least one field blank for each reactor aging cycle or round of testing performed under § 1065.1117. Field blanks must be contained in a sealed environment and accompany the reactor sampling system throughout the course of a test, including reactor disassembly, sample packaging, and storage. Use good engineering judgment to determine how frequently to generate field blanks. Keep the field blank sample close to the reactor during testing.

(d) Reactor blanks are used to determine if there is any contamination from the sampling system. Analyze at least one reactor blank for each reactor aging cycle or round of testing performed under § 1065.1117.

(1) Test reactor blanks with the reactor on and operated identically to that of a catalyst test in § 1065.1117 with the exception that when loading the reactor, only the alumina capture bed will be loaded (no catalyst sample is loaded for the reactor blank). We recommend acquiring reactor blanks with the reactor operating at average test temperature you used when acquiring your test samples under § 1065.1117.

(2) You must run at least three reactor blanks if the result from the initial blank analysis is above the detection limit of the method, with additional blank runs based on the uncertainty of the reactor blank measurements, consistent with good engineering judgment.

§ 1065.1121 Vanadium sample dissolution and analysis in alumina capture beds.

This section describes the process for dissolution of vanadium from the vanadium sublimation samples collect in § 1065.1117 and any blanks collected in § 1065.1119 as well as the analysis of the digestates to determine the mass of vanadium emitted and the associated sublimation temperature threshold based on the results of all the samples taken during the reactor aging cycle.

(a) Digest the samples using the following procedure, or an equivalent procedure:

(1) Place the recovered alumina, a portion of the ground quartz tube from the reactor, and the quartz wool in a Teflon pressure vessel with a mixture made from 1.5 mL of 16 N HNO₃, 0.5 mL of 28 N HF, and 0.2 mL of 12 N HCl. Note that the amount of ground quartz tube from the reactor included in the digestion can influence the vanadium concentration of both the volatilized vanadium from the sample and the method detection limit. You must be consistent with the amount ground quartz tube included in the sample analysis for your testing. You must limit the amount of quartz tube to include only portions of the tube that would be likely to encounter volatilized vanadium.

(2) Program a microwave oven to heat the sample to 180 °C over 9 minutes, followed by a 10-minute hold at that temperature, and 1 hour of ventilation/cooling.

(3) After cooling, dilute the digests to 30 mL with high purity 18MΩ water prior to ICP-MS (or ICP-OES) analysis. Note that this digestion technique requires adequate safety measures when working with HF at high temperature and pressure. To avoid “carry-over” contamination, rigorously clean the vessels between samples as described in “Microwave digestion procedures for environmental matrixes” (Lough, G.C. *et al*, *Analyst*. 1998, 123 (7), 103R-133R).

(b) Analyze the digestates for vanadium as follows:

(1) Perform the analysis using ICP-OES (or ICP-MS) using standard plasma conditions (1350 W forward power) and a desolvating microconcentric nebulizer, which will significantly reduce oxide- and chloride-based interferences.

(2) We recommend that you digest and analyze a minimum of three solid vanadium NIST Standard Reference Materials in duplicate with every batch of 25 vanadium alumina capture bed samples that you analyze in this section, as described in “Emissions of metals associated with motor vehicle roadways” (Herner, J.D. *et al*, *Environmental Science and Technology*. 2005, 39, 826–836). This will serve as a quality assurance check to help gauge the relative uncertainties in each measurement, specifically if the measurement errors are normally distributed and independent.

(3) Use the 3-sigma approach to determine the analytical method detection limits for vanadium and the 10-sigma approach if you determine the reporting limit. This process involves analyzing at least seven replicates of a blank using the analytical method described in paragraphs (a) and (b)(1) of this section, converting the responses into concentration units, and calculating the standard deviation. Determine the detection limit by multiplying the standard deviation by 3 and adding it to the average. Determine the reporting limit by multiplying the standard deviation by 10 and adding it to the average. Determine the following analytical method detection limits:

(i) Determine the ICP-MS (or ICP-OES) instrumental detection limit (ng/L) by measuring at least seven blank samples made up of the reagents from paragraph (a) of this section.

(ii) Determine the method detection limit (pg/m³ of flow or pg/g of the total combined mass of the recovered alumina, a portion of the ground quartz tube from the reactor, and the quartz wool) by measuring at least seven reactor blank samples taken as described in § 1065.1119(d).

(iii) We recommend that your method detection limit determined under paragraph (b)(3)(iii) of this section is at or below 2 ppm (2 pg/m³). You must report your detection limits determined in this paragraph (b)(3) and reporting limits (if determined) with your test results.

(4) If you account for vanadium-loaded particles contaminating catalyst-coated monoliths as a result of physical abrasion as allowed in § 1065.1115(f), use the 3-sigma approach to determine the analytical method detection limits for titanium and the 10-sigma approach

if you determine the reporting limit. This process involves analyzing at least seven replicates of a blank using the analytical method described in paragraphs (a) and (b)(1) of this section, converting the responses into concentration units, and calculating the standard deviation. Determine the detection limit by multiplying the standard deviation by 3 and subtracting it from the average. Determine the reporting limit by multiplying the standard deviation by 10 and subtracting it from the average.

(i) Determine the ICP-MS (or ICP-OES) instrumental detection limit (ng/L) by measuring at least seven blank samples made up of the reagents from paragraph (a) of this section.

(ii) Determine the method detection limit (pg/m³ of flow or pg/g of the total combined mass of the recovered alumina, a portion of the ground quartz tube from the reactor, and the quartz wool) by measuring at least seven reactor blank samples taken as described in § 1065.1119(d).

244. _____ Amend subpart L by adding a new center header “SMOKE OPACITY” after the newly added § 1065.1121 and adding §§ 1065.1123, 1065.1125, and 1065.1127 under the new center header to read as follows:

SMOKE OPACITY

§ 1065.1123 General provisions for determining exhaust opacity.

The provisions of §1065.1125 describe system specifications for measuring percent opacity of exhaust for all types of engines. The provisions of §1065.1127 describe how to use such a system to determine percent opacity of engine exhaust for applications other than locomotives. See 40 CFR 1033.525 for measurement procedures for locomotives.

§ 1065.1125 Exhaust opacity measurement system.

Smokemeters measure exhaust opacity using full-flow open-path light extinction with a built-in light beam across the exhaust stack or plume. Prepare and install a smokemeter system as follows:

(a) Except as specified in paragraph (d) of this section, use a smokemeter capable of providing continuous measurement that meets the following specifications:

(1) Use an incandescent lamp with a color temperature between (2800 and 3250) K or a different light source with a spectral peak between (550 and 570) nm.

(2) Collimate the light beam to a nominal diameter of 3 centimeters and maximum divergence angle of 6 degrees.

(3) Include a photocell or photodiode as a detector. The detector must have a maximum spectral response between (550 and 570) nm, with less than 4 percent of that maximum response below 430 nm and above 680 nm. These specifications correspond to visual perception with the human eye.

(4) Use a collimating tube with an aperture that matches the diameter of the light beam. Restrict the detector to viewing within a 16 degree included angle.

(5) Optionally use an air curtain across the light source and detector window to minimize deposition of smoke particles, as long as it does not measurably affect the opacity of the sample.

(6) The diagram in the following figure illustrates the smokemeter configuration:

Figure 1 of § 1065.1125— Smokemeter Diagram.

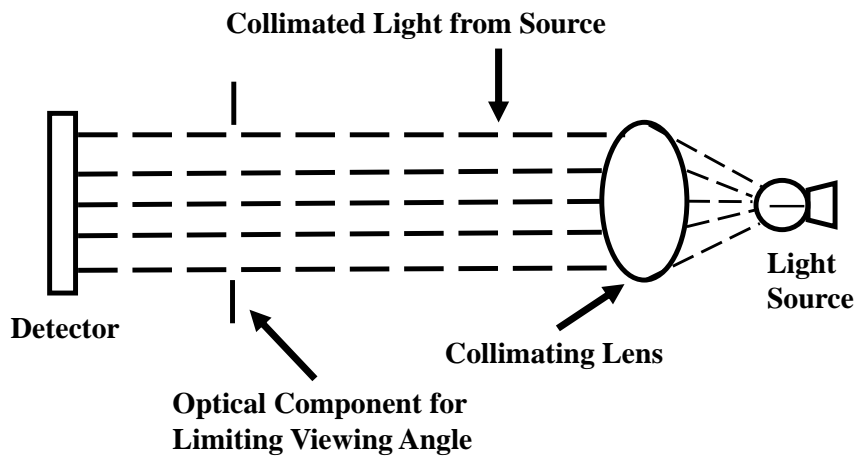

(b) Smokemeters for locomotive applications must have a full-scale response time of 0.5 seconds or less. Smokemeters for locomotive applications may attenuate signal responses with frequencies higher than 10 Hz with a separate low-pass electronic filter that has the following performance characteristics:

- (1) Three decibel point: 10 Hz.
- (2) Insertion loss: (0.0 ±0.5) dB.
- (3) Selectivity: 12 dB down at 40 Hz minimum.
- (4) Attenuation: 27 dB down at 40 Hz minimum.

(c) Configure exhaust systems as follows for measuring exhaust opacity:

- (1) For locomotive applications:
 - (i) Optionally add a stack extension to the locomotive muffler.
 - (ii) For in-line measurements, the smokemeter is integral to the stack extension.
 - (iii) For end-of-line measurements, mount the smokemeter directly at the end of the stack extension or muffler.
 - (iv) For all testing, minimize distance from the optical centerline to the muffler outlet; in no case may it be more than 300 cm. The maximum allowable distance of unducted space upstream of the optical centerline is 50 cm, whether the unducted portion is upstream or downstream of the stack extensions.
- (2) Meet the following specifications for all other applications:
 - (i) For in-line measurements, install the smokemeter in an exhaust pipe segment downstream of all engine components. This will typically be part of a laboratory configuration to route the exhaust to an analyzer. The exhaust pipe diameter must be constant within 3 exhaust pipe diameters before and after the smokemeter's optical centerline. The exhaust pipe diameter may not change by more than a 12-degree half-angle within 6 exhaust pipe diameters upstream of the smokemeter's optical centerline.
 - (ii) For end-of-line measurements with systems that vent exhaust to the ambient, add a stack extension and position the smokemeter such that its optical centerline is (2.5 ±0.625) cm upstream of the stack extension's exit. Configure the exhaust stack and extension such that at least the last 60 cm is a straight pipe with a circular cross section with an approximate inside diameter as specified in the following table:

Table 1 of § 1065.1125— Approximate Exhaust Pipe Diameter Based on Engine Power

<u>Maximum rated horsepower</u>	<u>Approximate exhaust pipe diameter (mm)</u>
---------------------------------	---

<u>kW<40</u>	<u>38</u>
<u>40<kW<75</u>	<u>50</u>
<u>75<kW<150</u>	<u>76</u>
<u>150<kW<225</u>	<u>102</u>
<u>225<kW<375</u>	<u>127</u>
<u>kW> 375</u>	<u>152</u>

(iii) For both in-line and end-of-line measurements, install the smokemeter so its optical centerline is (3 to 10) meters further downstream than the point in the exhaust stream that is farthest downstream considering all the following components: exhaust manifolds, turbocharger outlets, exhaust aftertreatment devices, and junction points for combining exhaust flow from multiple exhaust manifolds.

(3) Orient the light beam perpendicular to the direction of exhaust flow. Install the smokemeter so it does not influence exhaust flow distribution or the shape of the exhaust plume. Set up the smokemeter's optical path length as follows:

(i) For locomotive applications, the optical path length must be at least as wide as the exhaust plume.

(ii) For all other applications, the optical path length must be the same as the diameter of the exhaust flow. For noncircular exhaust configurations, set up the smokemeter such that the light beam's path length is across the longest axis with an optical path length equal to the hydraulic diameter of the exhaust flow.

(4) The smokemeter must not interfere with the engine's ability to meet the exhaust backpressure requirements in § 1065.130(h).

(5) For engines with multiple exhaust outlets, measure opacity using one of the following methods:

(i) Join the exhaust outlets together to form a single flow path and install the smokemeter (3 to 10) m downstream of the point where the exhaust streams converge or the last exhaust aftertreatment device, whichever is farthest downstream.

(ii) Install a smokemeter in each of the exhaust flow paths. Report all measured values. All measured values must comply with standards.

(6) The smokemeter may use purge air or a different method to prevent carbon or other exhaust deposits on the light source and detector. Such a method used with end-of-line measurements may not cause the smoke plume to change by more than 0.5 cm at the smokemeter. If such a method affects the smokemeter's optical path length, follow the smokemeter manufacturer's instructions to properly account for that effect.

(d) You may use smokemeters meeting alternative specifications as follows:

(1) You may use smokemeters that use other electronic or optical techniques if they employ substantially identical measurement principles and produce substantially equivalent results.

(2) You may ask us to approve the use of a smokemeter that relies on partial flow sampling. Follow the instrument manufacturer's installation, calibration, operation, and maintenance procedures if we approve your request. These procedures must include correcting for any change in the path length of the exhaust plume relative to the diameter of the engine's exhaust outlet.

§ 1065.1127 Test procedure for determining percent opacity.

The test procedure described in this section applies for everything other than locomotives. The test consists of a sequence of engine operating points on an engine dynamometer to measure

exhaust opacity during specific engine operating modes to represent in-use operation. Measure opacity using the following procedure:

(a) Use the equipment and procedures specified in this part 1065.

(b) Calibrate the smokemeter as follows:

(1) Calibrate using neutral density filters with approximately 10, 20, and 40 percent opacity. Confirm that the opacity values for each of these reference filters are NIST-traceable within 185 days of testing, or within 370 days of testing if you consistently protect the reference filters from light exposure between tests.

(2) Before each test and optionally during engine idle modes, remove the smokemeter from the exhaust stream, if applicable, and calibrate as follows:

(i) Zero. Adjust the smokemeter to give a zero response when there is no detectable smoke.

(ii) Linearity. Insert each of the qualified reference filters in the light path perpendicular to the axis of the light beam and adjust the smokemeter to give a result within 1 percentage point of the named value for each reference filter.

(c) Prepare the engine, dynamometer, and smokemeter for testing as follows:

(1) Set up the engine to run in a configuration that represents in-use operation.

(2) Determine the smokemeter's optical path length to the nearest mm.

(3) If the smokemeter uses purge air or another method to prevent deposits on the light source and detector, adjust the system according to the system manufacturer's instructions and activate the system before starting the engine.

(4) Program the dynamometer to operate in torque-control mode throughout testing. Determine the dynamometer load needed to meet the cycle requirements in paragraphs (d)(4)(ii) and (iv) of this section.

(5) You may program the dynamometer to apply motoring assist with negative flywheel torque, but only during the first 0.5 seconds of the acceleration events in paragraphs (d)(4)(i) and (ii). Negative flywheel torque may not exceed 13.6 N·m.

(d) Operate the engine and dynamometer over repeated test runs of the duty cycle illustrated in Figure 1 of this appendix. As noted in the figure, the test run includes an acceleration mode from points A through F in the figure, followed by a lugging mode from points I to J. The following paragraphs describe the detailed specifications for testing:

(1) Continuously record opacity, engine speed, engine torque, and operator demand over the course of the entire test at 10 Hz; however, you may interrupt measurements to recalibrate during each idle mode.

(2) Precondition the engine by operating it for 10 minutes at maximum mapped power.

(3) Operate the engine for (5.0 to 5.5) minutes at warm idle speed, f_{idle} , with load set to Curb Idle Transmission Torque.

(4) Operate the engine and dynamometer as follows during the acceleration mode:

(i) First acceleration event—AB. Partially increase and hold operator demand to stabilize engine speed briefly at (200 ± 50) r/min above f_{idle} . The start of this acceleration is the start of the test ($t = 0$ s).

(ii) Second acceleration event—CD. As soon as measured engine speed is within the range specified in paragraph (d)(4)(i) of this section, but not more than 3 seconds after the start of the test, rapidly set and hold operator demand at maximum. Operate the dynamometer using a preselected load to accelerate engine speed to 85 percent of maximum test speed, f_{test} , in (5 ± 1.5) seconds. The engine speed throughout the acceleration must be within ± 100 r/min of a target represented by a linear transition between the low and high engine speed targets.

(iii) Transition—DEF. As soon as measured engine speed reaches 85 percent of f_{ntest} , rapidly set and hold operator demand at minimum and simultaneously apply a load to decelerate to intermediate speed in (0.5 to 3.5) seconds. Use the same load identified for the acceleration event in paragraph (d)(4)(iv) of this section.

(iv) Third acceleration event—FGH. Rapidly set and hold operator demand at maximum when the engine is within ± 50 r/min of intermediate speed. Operate the dynamometer using a preselected load to accelerate engine speed to at least 95 percent of f_{ntest} in (10 ± 2) seconds.

(5) Operate the engine and dynamometer as follows during the lugging mode:

(i) Transition—HI. When the engine reaches 95 percent of f_{ntest} , keep operator demand at maximum and immediately set dynamometer load to control the engine at maximum mapped power. Continue the transition segment for (50 to 60) seconds. For at least the last 10 seconds of the transition segment, hold engine speed within ± 50 r/min of f_{ntest} and power at or above 95 percent of maximum mapped power. Conclude the transition by increasing dynamometer load to reduce engine speed as specified in paragraph (d)(4)(iii) of this section, keeping operator demand at maximum.

(ii) Lugging—IJ. Apply dynamometer loading as needed to decrease engine speed from 50 r/min below f_{ntest} to intermediate speed in (35 ± 5) seconds. The engine speed must remain within ± 100 r/min of a target represented by a linear transition between the low and high engine speed targets.

(6) Return the dynamometer and engine controls to the idle position described in paragraph (d)(3) of this section within 60 seconds of completing the lugging mode.

(7) Repeat the procedures in paragraphs (d)(3) through (6) of this section as needed to complete three valid test runs. If you fail to meet the specifications during a test run, continue to follow the specified duty cycle before starting the next test run.

(8) Shut down the engine or remove the smokemeter from the exhaust stream to verify zero and linearity. Void the test if the smokemeter reports more than 2 percent opacity for the zero verification, or if the smokemeter's error for any of the linearity checks specified in paragraph (b)(2) of this section is more than 2 percent.

(e) Analyze and validate the test data as follows:

(1) Divide each test run into test segments. Each successive test segment starts when the preceding segment ends. Identify the test segments based on the following criteria:

(i) The idle mode specified in paragraph (d)(3) of this section for the first test run starts immediately after engine preconditioning is complete. The idle mode for later test runs must start within 60 seconds after the end of the previous test run as specified in paragraph (d)(6) of this section. The idle mode ends when operator demand increases for the first acceleration event (Points A and B).

(ii) The first acceleration event in paragraph (d)(4)(i) of this section ends when operator demand is set to maximum for the second acceleration event (Point C).

(iii) The second acceleration event in paragraph (d)(4)(ii) of this section ends when the engine reaches 85 percent of maximum test speed, f_{ntest} , (Point D) and operator demand is set to minimum (Point E).

(iv) The transition period in paragraph (d)(4)(iii) of this section ends when operator demand is set to maximum (Point F).

(v) The third acceleration event in paragraph (d)(4)(iv) of this section ends when engine speed reaches 95 percent of f_{ntest} (Point H).

(vi) The transition period in paragraph (d)(5)(i) of this section ends when engine speed first decreases to a point more than 50 r/min below f_{ntest} (Point I).

(vii) The lugging mode in paragraph (d)(5)(ii) of this section ends when the engine reaches intermediate speed (Point J).

(2) Convert measured instantaneous values to standard opacity values, κ_{std} , based on the appropriate optical path length specified in Table 1 of §1065.1125 using the following equation:

$$\kappa_{std} = 100 \cdot \left(1 - \left(1 - \frac{\kappa_{meas}}{100} \right)^{\frac{l_{std}}{l_{meas}}} \right)$$

Eq. 1065.1127-1

Where:

κ_{std} = standard instantaneous percent opacity.

κ_{meas} = measured instantaneous percent opacity.

l_{std} = standard optical path length corresponding with engine power, in millimeters.

l_{meas} = the smokemeter's optical path length, in millimeters.

Example for an engine < 40 kW:

$\kappa_{meas} = 14.1 \%$

$l_{std} = 38 \text{ mm}$

$l_{meas} = 41 \text{ mm}$

$$\kappa_{std} = 100 \cdot \left(1 - \left(1 - \frac{14.1}{100} \right)^{\frac{38}{41}} \right) = 13.1 \%$$

(3) Select opacity results from corrected measurements collected across test segments as follows:

(i) Divide measurements from acceleration and lugging modes into half-second intervals. Determine average opacity values during each half-second interval.

(ii) Identify the 15 highest half-second values during the acceleration mode of each test run.

(iii) Identify the five highest half-second values during the lugging mode of each test run.

(iv) Identify the three overall highest values from paragraphs (e)(3)(ii) and (iii) of this section for each test run.

(f) Determine percent opacity as follows:

(1) Acceleration. Determine the percent opacity for the acceleration mode by calculating the average of the 45 readings from paragraph (e)(3)(ii) of this section.

(2) Lugging. Determine the percent opacity for the lugging mode by calculating the average of the 15 readings from paragraph (e)(3)(iii) of this section.

(3) Peak. Determine the percent opacity for the peaks in either acceleration or lugging mode by calculating the average of the 9 readings from paragraph (e)(3)(iv) of this section.

(g) Submit the following information in addition to what is required by § 1065.695:

(1) Exhaust pipe diameter(s).

(2) Measured maximum exhaust system backpressure over the entire test.

(3) Most recent date for establishing that each of the reference filters from paragraph (b) of this section are NIST-traceable.

(4) Measured smokemeter zero and linearity values after testing.

(5) 10 Hz data from all valid test runs.

(h) The following figure illustrates the dynamometer controls and engine speeds for exhaust opacity testing:

Figure 1 of § 1065.1127– Schematic of Smoke Opacity Duty Cycle

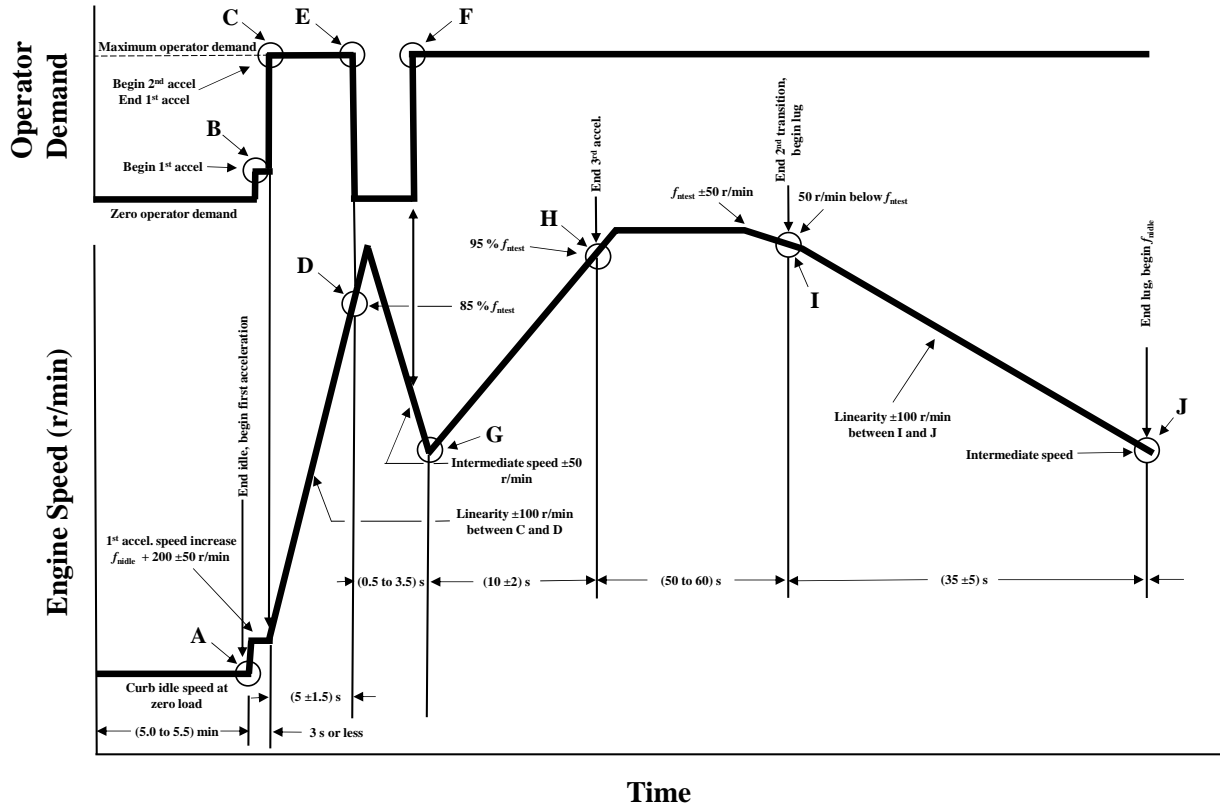

PART 1066—VEHICLE-TESTING PROCEDURES

~~244.~~245. The authority citation for part 1066 continues to read as follows:
Authority: 42 U.S.C. 7401 - 7671q.

~~245.~~246. Amend §1066.110 by revising paragraphs (b)(2)(i) and (v) to read as follows:

§1066.110 Equipment specifications for emission sampling systems.

* * * * *

(b) * * *

(2) * * *

(i) For PM background measurement, the following provisions apply ~~instead of the analogous~~ in addition to the provisions in 40 CFR 1065.140(b):

* * * * *

(v) If you choose to dilute the exhaust by using a remote mix tee, which dilutes the exhaust at the tailpipe, you may use the following provisions consistent with good engineering judgment, as long as they do not affect your ability to demonstrate compliance with the applicable standards in this chapter:

* * * * *

~~246.~~247. Amend §1066.220 by revising paragraph (b) to read as follows:

§1066.220 Linearity verification for chassis dynamometer systems.

* * * * *

(b) *Performance requirements.* If a measurement system does not meet the applicable linearity criteria in Table 1 of this section, correct the deficiency by re-calibrating, servicing, or replacing components as needed. Repeat the linearity verification after correcting the deficiency to ensure that the measurement system meets the linearity criteria. Before you may use a measurement system that does not meet linearity criteria, you must demonstrate to us that the deficiency does not adversely affect your ability to demonstrate compliance with the applicable standards in this chapter.

* * * * *

~~247.~~248. Amend §1066.415 by revising paragraph (e)(2) to read as follows:

§1066.415 Vehicle operation.

* * * * *

(e) * * *

(2) If vehicles have features that preclude dynamometer testing, you may modify these features as necessary to allow testing, consistent with good engineering judgment, as long as it does not affect your ability to demonstrate that your vehicles comply with the applicable standards in this chapter. Send us written notification describing these changes along with supporting rationale.

* * * * *

~~248.249.~~ Amend §1066.420 by revising paragraph (b) to read as follows:

§1066.420 Test preparation.

* * * * *

(b) Minimize the effect of nonmethane hydrocarbon contamination in the hydrocarbon sampling system as follows:

(1) For vehicles at or below 14,000 pounds GVWR with compression-ignition engines, account for contamination using one of the following methods:

(i) Introduce zero and span gas during analyzer calibration using one of the following methods, noting that the hydrocarbon analyzer flow rate and pressure during zero and span calibration (and background bag reading) must be exactly the same as that used during testing to minimize measurement errors:

(A) Close off the hydrocarbon sampling system sample probe and introduce gases downstream of the probe making sure that you do not pressurize the system.

(B) Introduce zero and span gas directly at the hydrocarbon sampling system probe at a flow rate greater than 125 % of the hydrocarbon analyzer flow rate allowing some gas to exit probe inlet.

(ii) Perform the contamination verification in paragraph (b)(2) of this section.

(2) For vehicles above 14,000 pounds GVWR with compression-ignition engines, verify the amount of nonmethane hydrocarbon contamination as described in 40 CFR 1065.520(f).

* * * * *

~~249.250.~~ Amend §1066.710 by revising the introductory text, removing Figure 1, and adding paragraph (f) to read as follows:

§1066.710 Cold temperature testing procedures for measuring CO and NMHC emissions and determining fuel economy.

This section describes procedures for measuring carbon monoxide (CO) and nonmethane hydrocarbon (NMHC) emissions and determining fuel economy on a cold day using the FTP test cycle -(see § 1066.801).~~The following figure illustrates the test procedure:~~

* * * * *

(f) The following figure illustrates the cold temperature testing sequence for measuring CO and NMHC emissions and determining fuel economy:

Figure 1 of § 1066.710— Cold Temperature Testing Sequence for Measuring CO and NMHC Emissions and Determining Fuel Economy

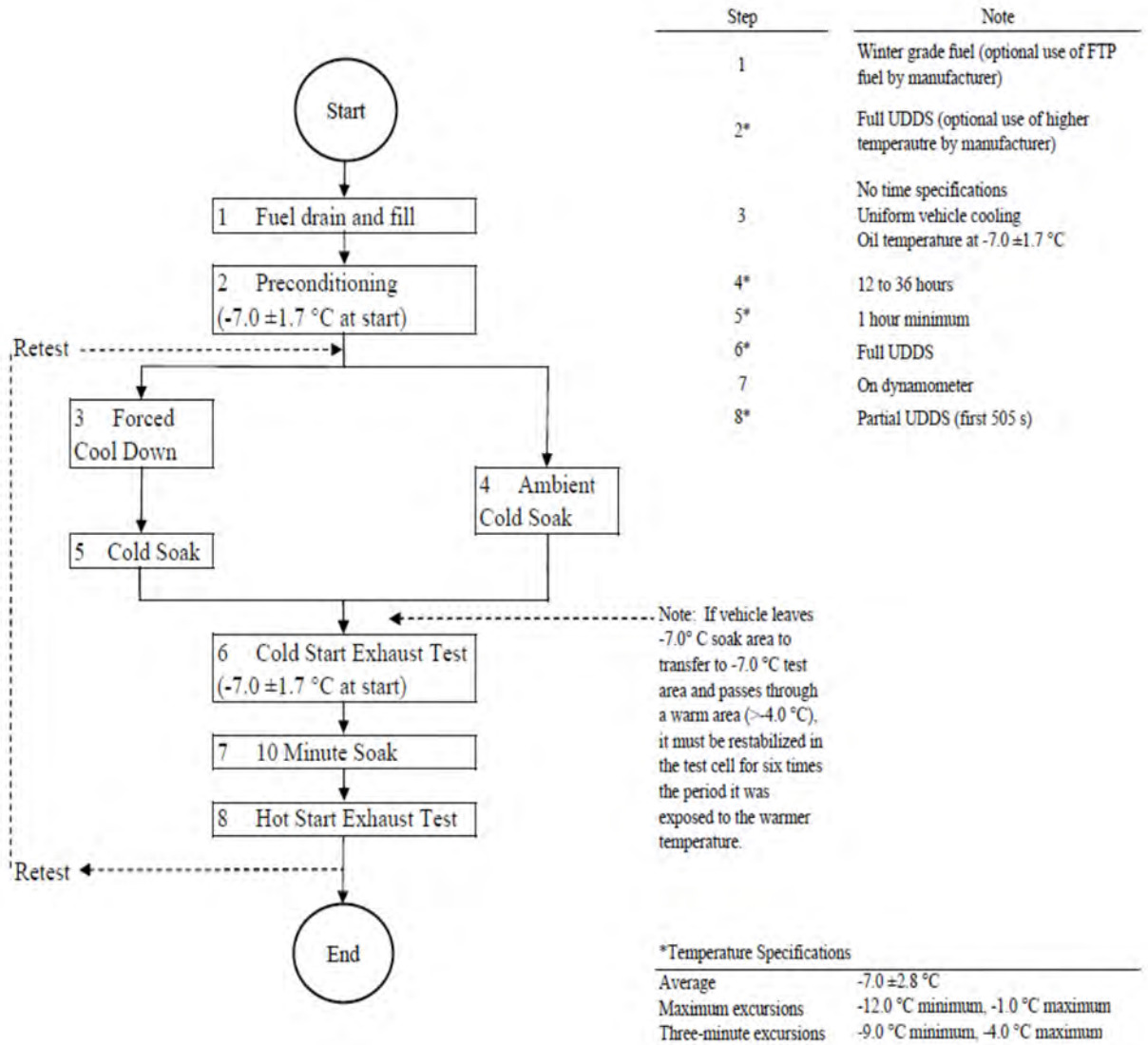

~~250.~~251. Amend §1066.815 by revising paragraph (d)(1)(ii) to read as follows:

§ 1066.815 Exhaust emission test procedures for FTP testing.

* * * * *

(d) * * *

(1) * * *

(ii) Simultaneously start any electronic integrating devices, continuous data recording, and batch sampling before attempting to start the engine. Initiate the sequence of points in the test cycle when the engine starts. ~~Start sampling and recording simultaneously with starting the vehicle.~~

Place the vehicle in gear 15 seconds after engine starting, which is 5 seconds before the first acceleration.

* * * * *

~~251.~~252. Amend §1066.831 by revising paragraph (d) to read as follows:

§1066.831 Exhaust emission test procedures for aggressive driving.

* * * * *

(d) For diesel-fueled vehicles, measure THC emissions on a continuous basis ~~as described in 40 CFR part 1065~~. For separate measurement of the city and highway test intervals as described in paragraph (c) of this section, perform separate calculations for each portion of the test cycle.

* * * * *

~~252.~~253. Amend §1066.835 by revising paragraph (f)(1), (2), and (3)(iii) to read as follows:

§1066.835 Exhaust emission test procedure for SC03 emissions.

* * * * *

(f) * * *

(1) *Ambient temperature and humidity.* Measure and record ambient temperature and humidity in the test cell at least once every 30 seconds during the sampling period. Alternatively, if you collect data of at least once every 12 seconds, you may use a moving average of up to 30 second intervals to measure and record ambient temperature and humidity. Control ambient temperature throughout the test sequence to (35.0 ± 3.0) °C. Control ambient temperature during emission sampling to $(33.6$ to $36.4)$ °C on average. Control ambient humidity during emission sampling as described in § 1066.420(d).

(2) *Conditions before ~~and after~~ testing.* Use good engineering judgment to demonstrate that you meet the specified temperature and humidity tolerances in paragraph (f)(1) of this section during the preconditioning cycle and during the vehicle soak period in paragraph (c)(6) of this section ~~at all times before and between emission measurements.~~

(3) * * *

(iii) Determine radiant energy intensity experienced by the vehicle as the average value between two measurements along the vehicle's centerline, one at the base of the windshield and the other at the bottom of the rear window (or equivalent location for vehicles without a rear window). This value must be (850 ± 45) W/m². Instruments for measuring radiant energy intensity must meet the following minimum specifications:

* * * * *

~~253.254.~~ Amend §1066.845 by revising paragraphs (c) and (f)(3) to read as follows:

§1066.845 AC17 air conditioning efficiency test procedure.

* * * * *

(c) *Ambient conditions.* Measure and control ambient conditions as specified in § 1066.835(f), except that you must control ambient temperature during emission sampling to (22.0 to 28.0) °C throughout the test and (23.5 to 26.5) °C on average. These tolerances apply to the combined SC03 and HFET drive cycles during emission sampling. Note that you must set the same ambient temperature target for both the air conditioning on and off portions of emission sampling. Control ambient temperature during the preconditioning cycle and 30 minute soak to (25.0 ±5.0) °C. For these same modes with no emission sampling, target the specified ambient humidity levels, but you do not need to meet the humidity tolerances. Note that solar heating is disabled for certain test intervals as described in this section.

* * * * *

(f) * * *

(3) Turn on solar heating within one minute after turning off the engine. Once the solar energy intensity reaches 805 W/m², let the vehicle soak for (30 ±1) minutes. You may alternatively rely on prior measurements to start the soak period after a defined period of warming up to the specified solar heat load. Close the vehicle's windows at the start of the soak period; ensure that the windows are adequately closed where instrumentation and wiring pass through to the interior.

* * * * *

~~254.255.~~ Amend §1066.1001 by adding definitions for “Charge-depleting” and “Charge-sustaining in alphabetical order and revising the definition for “Test interval” to read as follows:

§1066.1001 Definitions.

* * * * *

Charge-depleting means relating to the test interval of a plug-in hybrid engine or powertrain in which the engine or powertrain consumes electric energy from the RESS that has been charged from an external power source until the RESS is depleted to the point that a test interval qualifies as charge-sustaining. The engine might consume fuel to produce power during a charge-depleting test interval.

Charge-sustaining means relating to the test interval of a plug-in hybrid engine or powertrain in which the engine or powertrain consumes fuel to produce power such that the battery's net-energy change meets the end-of-test criterion of SAE J1711 or SAE J2711, as applicable (incorporated by reference in §1066.1010).

* * * * *

Test interval means a period over which a vehicle's emission rates are determined separately. For many standards, compliance with the standard is based on a weighted average of the mass emissions from multiple test intervals. For example, the standard-setting part may specify a complete duty cycle as a cold-start test interval and a hot-start test interval. In cases where multiple test intervals occur over a duty cycle, the standard-setting part may specify additional calculations that weight and combine results to arrive at composite values for comparison against the applicable standards in this chapter.

* * * * *

255:256. Amend §1066.1005 by revising paragraphs (b), (g), and (h) to read as follows:

§1066.1005 Symbols, abbreviations, acronyms, and units of measure.

* * * * *

(b) *Symbols for chemical species.* This part uses the following symbols for chemical species and exhaust constituents:

Table 2 of §1066.1005—Symbols for Chemical Species and Exhaust Constituents

Symbol	Species
CH ₄	methane.
CH ₃ OH	methanol.
CH ₂ O	formaldehyde.
C ₂ H ₄ O	acetaldehyde.
C ₂ H ₅ OH	ethanol.
C ₂ H ₆	ethane.
C ₃ H ₇ OH	propanol.
C ₃ H ₈	propane.
C ₄ H ₁₀	butane.
C ₅ H ₁₂	pentane.
CO	carbon monoxide.
CO ₂	carbon dioxide.
H ₂ O	water.
HC	hydrocarbon.
N ₂	molecular nitrogen.
NMHC	nonmethane hydrocarbon.
NMHCE	nonmethane hydrocarbon equivalent.
NMOG	nonmethane organic gas.
NO	nitric oxide.
NO ₂	nitrogen dioxide.
NO _x	oxides of nitrogen.
N ₂ O	nitrous oxide.
O ₂	molecular oxygen.
OHC	oxygenated hydrocarbon.
PM	particulate matter.
THC	total hydrocarbon.
THCE	total hydrocarbon equivalent.

* * * * *

(g) *Constants.* (1) This part uses the following constants for the composition of dry air:

Table 7 of §1066.1005—Constants for the Composition of Dry Air

Symbol	Quantity	mol/mol
x_{Arair}	amount of argon in dry air	0.00934
x_{CO2air}	amount of carbon dioxide in dry air	0.000375
x_{N2air}	amount of nitrogen in dry air	0.78084
x_{O2air}	amount of oxygen in dry air	0.209445

(2) This part uses the following molar masses or effective molar masses of chemical species:

Table 8 of §1066.1005—Molar Masses or Effective Molar Masses of Chemical Species

Symbol	Quantity	g/mol (10 ⁻³ ·kg·mol ⁻¹)
M_{air}	molar mass of dry air ¹	28.96559
$M_{\text{H}_2\text{O}}$	molar mass of water	18.01528

¹See paragraph (g)(1) of this section for the composition of dry air.

(3) This part uses the following molar gas constant for ideal gases:

Table 9 of §1066.1005—Molar Gas Constant for Ideal Gases

Symbol	Quantity	J/(mol·K) (m ² ·kg·s ⁻² ·mol ⁻¹ ·K ⁻¹)
R	molar gas constant	8.314472

(h) *Prefixes*. This part uses the following prefixes to define a quantity:

Table 10 of §1066.1005—Prefixes to Define a Quantity

Symbol	Quantity	Value
n	nano	10 ⁻⁹
u	micro	10 ⁻⁶
m	milli	10 ⁻³
c	centi	10 ⁻²
k	kilo	10 ³
M	mega	10 ⁶

~~256.257.~~ Amend §1066.1010 by revising paragraphs (b)(2)-(4), and (6) to read as follows:

§1066.1010 Incorporation by reference.

* * * * *

(b) * * *

(2) SAE J1634, Battery Electric Vehicle Energy Consumption and Range Test Procedure, revised ~~July 2017~~~~October 2012~~, IBR approved for § 1066.501(a).

(3) SAE J1711, Recommended Practice for Measuring the Exhaust Emissions and Fuel Economy of Hybrid-Electric Vehicles, Including Plug-In Hybrid Vehicles, revised June 2010, IBR approved for §§ 1066.501(a) and 1066.1010.

(4) SAE J2263, Road Load Measurement Using Onboard Anemometry and Coastdown Techniques, revised ~~May 2020~~~~December 2008~~, IBR approved for §§ 1066.301(b), 1066.305, and 1066.310(b).

* * * * *

(6) SAE J2711, Recommended Practice for Measuring Fuel Economy and Emissions of Hybrid-Electric and Conventional Heavy-Duty Vehicles, revised May 2020~~issued September 2002~~, IBR approved for §§ 1066.501(a) and 1066.1001.

* * * * *

PART 1068—GENERAL COMPLIANCE PROVISIONS FOR HIGHWAY, STATIONARY, AND NONROAD PROGRAMS

~~257.258.~~ The authority citation for part 1068 continues to read as follows:
Authority: 42 U.S.C. 7401-7671q.

~~258.259.~~ Amend §1068.225 by revising paragraphs (a)(2), (5), (6), (8), (9), and (13) and adding paragraph (a)(15) to read as follows:

§1068.1 Does this part apply to me?

(a) * * *

(2) This part 1068 applies for heavy-duty motor vehicles and motor vehicle engines we regulate under 40 CFR parts 1036 and 1037, ~~subject to the provisions of 40 CFR parts 85 and 1037~~. This includes trailers. This part 1068 applies to ~~other~~ heavy-duty motor vehicles and motor vehicle engines certified under 40 CFR part 86 to the extent and in the manner specified in 40 CFR parts 85, 86, and 1036.

* * * * *

(5) This part 1068 applies for locomotives that are subject to the provisions of 40 CFR part 1033. ~~This part 1068 does not apply for locomotives or locomotive engines that were originally manufactured before July 7, 2008, and that have not been remanufactured on or after July 7, 2008.~~

(6) This part applies for land-based nonroad compression-ignition engines that are subject to the provisions of 40 CFR part 1039. This part 1068 applies for engines certified under 40 CFR part 89 to the extent and in the manner specified in 40 CFR part 1039.

* * * * *

(8) This part applies for marine compression-ignition engines that are subject to the provisions of 40 CFR part 1042. This part 1068 applies for marine compression-ignition engines certified under 40 CFR part 94 to the extent and in the manner specified in 40 CFR part 1042.

(9) This part 1068 applies for marine spark-ignition engines that are subject to the provisions of 40 CFR part 1045. This part 1068 applies for marine spark-ignition engines certified under 40 CFR part 91 to the extent and in the manner specified in 40 CFR part 1045.

* * * * *

(13) This part applies for small nonroad spark-ignition engines that are subject to the provisions of 40 CFR part 1054. This part 1068 applies for nonroad spark-ignition engines certified under 40 CFR part 90 to the extent and in the manner specified in 40 CFR part 1054.

* * * * *

(15) This part 1068 applies to portable fuel containers we regulate under 40 CFR part 59 to the extent and in the manner specified in 40 CFR part 59, subpart F.

* * * * *

~~259.260.~~ Revise §1068.10 to read as follows:

§1068.10 Practices for handling confidential business information.

The provisions of this section apply both to any information you send us and to any information we collect from inspections, audits, or other site visits.

(a) When you submit information to us, if you claim any of that information as confidential, ~~clearly show~~ you may identify what you claim to be confidential by marking, circling, bracketing, stamping, or some other method; however, we will not consider any claims of

confidentiality over information we have determined to be not entitled to confidential treatment under §1068.11 or other applicable provisions.

(b) If you send us information without claiming it is confidential, we may make it available to the public without further notice to you, as described in 40 CFR 2.301(j).

(c) For submissions that include information that may be entitled to confidential treatment, we may require that you send a “public” copy of the report that does not include the confidential information. We may require that you substantiate your claim to confidential treatment for any items not contained in the public version. We will release additional information from the complete version of such a submission only as allowed under 40 CFR 2.301(j) and as described in this subpart and the standard-setting part.

(d) We will safeguard your confidential business information (CBI) as described in 40 CFR 2.301(j). Also, we will treat certain information as confidential and will only disclose this information if it has been determined to be not entitled to confidential treatment as specified in §1068.11(c). The following general provisions describe how we will process requests for making information publicly available:

(1) *Certification information.* We will treat information submitted in an application for certification as confidential until the introduction-into-commerce date you identify in your application for certification consistent with 40 CFR 2.301(a)(2)(ii)(B). If we issue the certificate after your specified date, for the purpose of this section the introduction-into-commerce date is the date we issue the certificate. After that date, we will treat information submitted in an application for certification as described in §1068.11.

(2) *Preliminary and superseded information.* Preliminary and superseded versions of information you submit are covered by confidentiality determinations in the same manner as final documents. However, we will generally not disclose preliminary or superseded information unless we receive a request under 5 U.S.C. 552 that specifically asks for all versions of a document, including preliminary and superseded versions. We will consider a document preliminary if we have not reviewed it to verify its accuracy or if the reporting deadline has not yet passed. We will consider information superseded if you submit a new document or a revised application for certification to replace the earlier version.

(3) *Authorizing CBI disclosure.* The provisions of this section do not prevent us from disclosing protected information if you specifically authorize it.

(4) *Relationship to the standard-setting part.* The standard-setting part may identify additional provisions related to confidentiality determinations. Note that the standard-setting part identifies information requirements that apply for each type of engine/equipment. If this section identifies information that is not required for a given engine, that does not create a requirement to submit the information.

(5) *Changes in law.* The confidentiality determinations in this section and in the standard-setting parts may be changed through the processes described in 40 CFR 2.301(j)(4).

~~260,261.~~ Add §1068.11 to read as follows:

§1068.11 Confidentiality determinations and related procedures.

This section characterizes various categories of information for purposes of making confidentiality determinations, as follows:

(a) This paragraph (a) applies the definition of “Emission data” in 40 CFR 2.301(a) for information related to engines/equipment subject to this part. “Emission data” cannot be treated as confidential business information and shall be available to be disclosed to the public except as

specified in §1068.10(b)(1). The following categories of information qualify as emission data, except as specified in paragraph (c) of this section:

(1) Certification and compliance information, including information submitted in an application for a certificate of conformity that is used to assess compliance.

(2) Fleet value information, including information submitted for compliance with fleet average emission standards and emissions related ABT credit information, including the information used to generate credits.

(3) Source family information. For example, engine family information or test group information would identify the regulated emission source.

(4) Test information and results, including emission test results and other data from emission testing that are submitted in an application for a certificate of conformity, test results from in-use testing, production-line testing, and any other testing to demonstrate emissions. The information in this category includes all related information to characterize test results, document the measurement procedure, and modeling inputs and outputs where the compliance demonstration is based on computer modeling.

(5) ABT credit information, including information submitted for current and future compliance demonstrations using credits under an ABT program.

(6) Production volume, including information submitted for compliance with fleet average emission standards, compliance with requirements to test production engines/equipment, or compliance through ABT programs.

(7) Defect and recall information, including all information submitted in relation to a defect or recall except the remedial steps you identify in §1068.510(a)(2).

(8) Selective enforcement audit compliance information.

(b) The following categories of information are not eligible for confidential treatment, except as specified in §1068.10(d)(1):

(1) Published information, including information that is made available in annual and quarterly filings submitted to the U.S. Securities and Exchanges Commission, on company websites, or otherwise made publicly available by the information submitter.

(2) Observable information available to the public after the introduction to commerce date.

(c) The following categories of information are subject to the process for confidentiality determinations in 40 CFR part 2 as described in 40 CFR 2.301(j)(5).

(1) Projected sales and production volumes.

(2) Production start and end dates.

(3) Detailed description of emission control operation and function.

(4) Design specifications related to aftertreatment devices.

(5) Description of auxiliary emission control devices (AECDS).

(6) Plans for meeting regulatory requirements. For example, this applies for any projections of emission credits for the coming model year or determinations of the number of required repair facilities that are based on projected production volumes.

(7) The following information related to deterioration factors and other adjustment factors:

(i) Procedures to determine deterioration factors and other emission adjustment factors.

(ii) Any information used to justify those procedures.

(iii) Emission measurements you use to compare procedures or demonstrate that the procedures are appropriate.

(8) Financial information related to the following items:

(i) ABT credit transactions, including dollar amount, identity of parties, and contract information.

(ii) Meeting bond requirements, including aggregate U.S. asset holdings, financial details regarding specific assets, whether the manufacturer or importer obtains a bond, and copies of bond policies.

(9) Serial numbers or other information to identify specific engines or equipment selected for testing.

(10) Procedures that apply based on your request to test engines/equipment differently than we specify in the regulation. This applies for special and alternative test procedures. This also applies, for example, if we approve a broader or narrower zone of engine operation for not-to-exceed testing.

(11) Information related to testing vanadium catalysts in 40 CFR part 1065, subpart L.

(12) GPS data identifying the location for in-use emission measurements.

(13) Information related to possible defects that are subject to further investigation (not confirmed defects).

(d) If you submit information that is not addressed in paragraphs (a) through (c) of this section, you may claim the information as confidential. We may require you to provide us with information to substantiate your claims. If claimed, we may consider this substantiating information to be confidential to the same degree as the information for which you are requesting confidential treatment. We will make our determination based on your statements to us, the supporting information you send us, and any other available information. However, we may determine that your information is not subject to confidential treatment consistent with 40 CFR part 2 and 5 U.S.C. 552(b)(4).

(e) Applications for certification and submitted reports typically rely on software or templates to identify specific categories of information. If you submit information in a comment field designated for users to add general information, we will respond to requests for disclosing that information consistent with paragraphs (a) through (d) of this section.

~~261-262.~~ Amend §1068.30 by adding a definition for “Critical emission-related component” in alphabetical order and revising the definition of “Designated Compliance Officer” to read as follows:

§1068.30 Definitions.

* * * * *

Critical emission-related component means a component identified in appendix A of this part whose primary purpose is to reduce emissions or whose failure would commonly increase emissions without significantly degrading engine/equipment performance.

* * * * *

Designated Compliance Officer means one of the following:

(1) For motor vehicles regulated under 40 CFR part 86, subpart S: Director, Light-Duty Vehicle Center, U.S. Environmental Protection Agency, 2000 Traverwood Drive, Ann Arbor, MI 48105; complianceinfo@epa.gov; www.epa.gov/ve-certificationotaq/verify.

(2) For compression-ignition engines used in heavy-duty highway vehicles regulated under 40 CFR part 86, subpart A, and 40 CFR parts 1036 and 1037, and for nonroad and stationary compression-ignition engines or equipment regulated under 40 CFR parts 60, 1033, 1039, and 1042: Director, Diesel Engine Compliance Center, U.S. Environmental Protection Agency, 2000 Traverwood Drive, Ann Arbor, MI 48105; complianceinfo@epa.gov; www.epa.gov/ve-certificationotaq/verify.

(3) Director, Gasoline Engine Compliance Center, U.S. Environmental Protection Agency, 2000 Traverwood Drive, Ann Arbor, MI 48105; ~~nonroad-si-cert~~complianceinfo@epa.gov; www.epa.gov/ve-certification~~otaq/verify~~, for all the following engines and vehicles:

- (i) For spark-ignition engines used in heavy-duty highway vehicles regulated under 40 CFR part 86, subpart A, and 40 CFR parts 1036 and 1037,
- (ii) For highway motorcycles regulated under 40 CFR part 86, subpart E.
- (iii) For nonroad and stationary spark-ignition engines or equipment regulated under 40 CFR parts 60, 1045, 1048, 1051, 1054, and 1060.

~~262.263.~~ Add §1068.50 to read as follows:

§1068.50 Adjustable parameters.

(a) The standard-setting part generally requires that production engines, pre-production engines, and in-use engines with adjustable parameters meet all the requirements of this part for any adjustment in the physically adjustable range. This section refers to engines, because most adjustable parameters are integral to the engine even in the case of equipment-based standards. This section also applies for equipment-based adjustable parameters. The provisions of this section apply starting with model year 2024.

(b) You must use good engineering judgment for all decisions related to adjustable parameters. We recommend that you ask for preliminary approval for decisions related to new technologies, substantially changed engine designs, or new methods for limiting adjustability. Decisions related to adjustable parameters include the following:

- (1) Determining which engine operating parameters qualify as adjustable parameters.
- (2) Establishing the adequacy of the limits, stops, seals, or other means used to limit adjustment.
- (3) Defining the physically adjustable ranges for each such parameter.

(c) For purposes of this section, “operating parameter” means any feature that can, by the nature of its design, be adjusted to affect engine/equipment performance, including engine components that are designed to be replaced. For example, while bolts used to assemble the engine are practically adjustable (can be loosened or tightened), they are not adjustable parameters because they are not operating parameters. See paragraph (h) of this section for special provisions related to elements of design involving consumption and replenishment. A nonconsumable operating parameter is considered an adjustable parameter as follows:

(1) An operating parameter is not an adjustable parameter if we determine it is not practically adjustable using available tools, as described in paragraph (d) of this section, or we determine that engine operation over the full range of adjustment does not affect emissions without also degrading engine performance to the extent that operators will be aware of the problem. Also, while spark plug gap and valve lash are practically adjustable operating parameters, they are not adjustable parameters because adjusting them does not affect emissions without also degrading engine performance.

(2) The following specific criteria apply for determining whether a parameter is practically adjustable because it is permanently sealed or otherwise inaccessible:

- (i) Electronic components on circuit boards (such as onboard computers) are not practically adjustable if the board is encapsulated with a durable resin that adequately limits access to components on the board, consistent with paragraph (d)(1) of this section.
- (ii) Threaded fasteners (such as screws) on mechanically controlled engines are considered not practically adjustable if simple tools cannot be used to adjust the parameter once the head is sheared off after adjustment at the factory, or if the fastener is

recessed within a larger, permanent body and sealed with a durable plug, cap, or cover plate that adequately limits access to the fastener, consistent with paragraph (d)(1) of this section.

(iii) Bimetal springs on mechanically controlled engines are considered not practically adjustable if the plate covering the bimetal spring is riveted or welded in place or it is held in place with threaded fasteners meeting the specifications described in this paragraph (c)(2).

(d) The following provisions apply for determining whether operating parameters are “practically adjustable”:

(1) A mechanically controlled parameter is considered “not practically adjustable” if adjustments with ordinary tools take more than 15 minutes or involve service parts that cost more than \$30 for engines at or below 30 kW, or take more than 60 minutes or involve service parts that cost more than \$60 for engines between 30 kW and 560 kW. These costs are in 2020 dollars. Adjust these values for certification by comparing most recently available Consumer Price Index for All Urban Consumers (CPI-U) value published by the Bureau of Labor Statistics at www.usinflationcalculator.com. As used in this paragraph (d), the term “ordinary tools” includes hand tools, solvents, or other supplies that are reasonably available to the operator. Hand tools include screwdrivers, pliers, hammers, awls, wrenches, electric screwdrivers, electric drills, and any tools supplied by the manufacturer with the product. Any such items that are sold at hardware stores, automotive parts supply stores or on the Internet are considered available. The cost thresholds described in this paragraph (d)(1) do not include the cost of labor or the cost of any necessary tools or nonconsumable supplies; the time thresholds refer to the time required to access and adjust the parameter, excluding any time necessary to purchase parts, tools, or supplies or to perform testing. For engines at or above 560 kW, mechanically controlled parameters are considered “practically adjustable” if the parameter can be adjusted using any available tools. Determine the practically adjustable range of mechanically controlled parameters as described in paragraph (e) this section.

(2) Electronically controlled parameters are considered “practically adjustable” if they can be adjusted using any available tools (including devices that are used to alter computer code). Conversely, such parameters are not practically adjustable if you limit access to the electronic control units with password or encryption protection. You must have adequate protections in place to prevent distribution and use of passwords or encryption keys. We may exclude operating parameters (or narrow the adjustable range under paragraph (f) of this section) where we determine that the operating parameters will not be subject to in-use adjustment or will be subject to a more limited in-use adjustment. Our approval may include conditions to ensure that the certified configuration includes adjustable ranges that reflect the expected range of in-use adjustment. This paragraph (d)(2) applies for engines with any degree of electronic control. Determine the practically adjustable range of electronically controlled parameters as described in paragraph (f) of this section.

(e) A physical limit or stop is adequate for defining the limits of the practically adjustable range if it has the following characteristics:

(1) In the case of a threaded adjustment, the threads are terminated, pinned, or crimped to prevent additional travel without such that the operator cannot bypass the physical limit or stop without causing damage for which the repairs would exceed the time or cost thresholds specified in paragraph (d)(1) of this section.

(2) Operators cannot exceed the travel or rotation limits using ordinary tools without causing damage for which the repairs would exceed the time or cost thresholds specified in paragraph

(d)(1) of this section. For example, if a vehicle has a shim, bushing, or other device to limit flow rates, range of travel, or other parameters to prevent operating outside of a specified range of engine or vehicle speeds, you must take steps to prevent operators or mechanics from removing, replacing, or altering those parts to operate at a wider range of engine or vehicle speeds.

(f) Apply the following provisions to determine the practically adjustable range for electronically controlled parameters that can be adjusted by changing software or operating parameters (“reflashed”):

(1) If an engine family includes multiple algorithms that can be selected or are easily accessible, consider each of the available settings to be within the practically adjustable range.

(2) If you sell or offer to sell software or other products that could be used to reflash or otherwise modify the electronic control unit, consider all those settings to be within the practically adjustable range.

(3) If your engines/equipment have other electronic settings that can be modified or accessed as described in paragraph (d)(2) of this section, consider all those settings to be within the practically adjustable range. The following engine systems and features illustrate examples of the types of electronic settings for which this paragraph (f)(3) applies:

(i) Air-fuel setpoints for closed-loop fuel systems.

(ii) Reductant flow systems.

(iii) Base maps for fuel injection or spark timing.

(iv) Exhaust gas recirculation maps.

(g) We will make determinations regarding in-use adjustments of adjustable parameters under this section for certifying engines as follows:

(1) Our determinations will depend on in-use maintenance practices conforming to the maintenance and service information you provide. For example, if your published maintenance instructions describe routine procedures for adjusting engines or if you or your dealers make specialized tools available to operators, we will conclude that such adjustments are likely to occur. Also, your maintenance and service information may not specify adjustable ranges that are broader than those that you specify in your application for certification.

(2) We may review manufacturer statements under this section for certifying engines for a later model year if we learn from observation of in-use engines or other information that a parameter was in fact practically adjustable or that the specified operating range was in fact not correct. We may require you to include a new adjustable parameter or to revise your specified operating range for an adjustable parameter.

(h) Except as provided in the standard-setting part and this paragraph (h), engines are not in the certified configuration if you produce them with adjustable parameters set outside the range specified in your application for certification. Similarly, engines are not in the certified configuration if you produce them with other operating parameters that do not conform to the certified configuration. The following provisions apply for adjustable parameters related to elements of design involving consumption and replenishment, such as DEF tank fill level and hybrid battery state of charge:

(1) We will determine the range of adjustability based on the likelihood of in-use operation at a given point in the physically adjustable range. We may determine that operation in certain subranges within the physically adjustable range is sufficiently unlikely that the subranges should be excluded from the allowable adjustable range for testing.

(2) Shipping new engines/equipment in a state or configuration requiring replenishment to be within the range of adjustability for a certified configuration does not cause a violation of the prohibition in §1068.101(a)(1).

(i) In your application for certification, include information related to adjustable parameters as described in the standard-setting part and state that you meet the specifications of this section and provide supporting documentation for that statement as follows:

(1) If your engine is designed with mechanically controlled adjustable parameters, state that they meet the specifications of this section for preventing in-use operation outside the intended physically adjustable range.

(2) If your engine is designed with electronically controlled operating parameters that you consider “not practically adjustable,” state that you have restricted access to the electronic controls as specified in this section to prevent in-use operation outside the practically adjustable range.

(j) We may inspect your engines at any time to determine whether they meet the specifications of this section. We may purchase engines for testing, or we may ask you to supply engines for such inspections. We will inspect using ordinary tools and time limits specified in paragraph (d)(1) of this section and any available devices that alter computer code as specified in paragraph (d)(2) of this section. The inspection will determine the following:

(1) If the adjustable parameter is limited to the physically adjustable range specified in the manufacturer’s certification application.

(2) If physical stops for mechanically controlled adjustable parameters can be bypassed using methods outlined in paragraph (d)(1) of this section.

(k) Where we determine that you failed to identify something that should be considered an adjustable parameter, we may require you to treat the parameter as defective under §1068.501. If we determine you deliberately misrepresented the accessibility of the parameter or that you did not act in good faith, we may take action regarding your certificate as described in the standard-setting part (see, for example, 40 CFR 1054.255).

(l) Nothing in this section limits the tampering prohibition of §1068.101(b)(1) or the defeat device prohibition of §1068.101(b)(2).

~~263.264.~~ Amend §1068.101 by revising paragraphs (a) introductory text and (b)(5) to read as follows:

§1068.101 What general actions does this regulation prohibit?

* * * * *

(a) The following prohibitions and requirements apply to manufacturers of new engines, manufacturers of equipment containing these engines, ~~and~~ manufacturers of new equipment, and other persons as provided by §1068.1(a), except as described in subparts C and D of this part:

* * * * *

(b) * * *

(5) *Importation.* You may not import an uncertified engine or piece of equipment if it is defined to be new in the standard-setting part with a model year for which emission standards applied. Anyone violating this paragraph (b)(5) is deemed to be a manufacturer in violation of paragraph (a)(1) of this section. We may assess a civil penalty up to \$44,539 for each engine or piece of equipment in violation. Note the following: ~~is excluded~~

* * * * *

~~264.265.~~ Amend §1068.210 by revising paragraph (c) introductory text to read as follows:

§1068.210 Exempting test engines/equipment.

* * * * *

(c) If you are a certificate holder, you may request an exemption for engines/equipment you intend to include in a test programs ~~over a two-year period~~.

* * * * *

~~265.266.~~ Amend §1068.220 by revising paragraph (b) to read as follows:

§1068.220 Exempting display engines/equipment.

* * * * *

(b) Nonconforming display engines/equipment will be exempted if they are used only for displays in the interest of a business or the general public. ~~This~~ The exemption in this section does not apply to engines/equipment displayed for ~~private use, private collections, or any other~~ purpose we determine is inappropriate for a display exemption.

* * * * *

~~266.267.~~ Amend §1068.240 by revising paragraphs (a)(1), (b)(3), and (c)(3)(ii) to read as follows:

§1068.240 Exempting new replacement engines.

* * * * *

(a) * * *

(1) Paragraphs (b); and (c); ~~and (d)~~ of this section describe different approaches for exempting new replacement engines where the engines are specially built to correspond to an engine model from an earlier model year that was subject to less stringent standards than those that apply for current production (or is no longer covered by a certificate of conformity). You must comply with the requirements of paragraph (b) of this section for any number of replacement engines you produce in excess of what we allow under paragraph (c) of this section. You must designate engines you produce under this section as tracked engines under paragraph (b) of this section or untracked engines under paragraph (c) of this section by the deadline for the report specified in paragraph (c)(3) of this section.

* * * * *

(b) * * *

(3) An old engine block replaced by a new engine exempted under this paragraph (b) may be reintroduced into U.S. commerce as part of an engine that meets either the current standards for new engines, the provisions for new replacement engines in this section, or another valid exemption. Otherwise, you must destroy the old engine block (or confirm that it has been destroyed), or export the engine block without its emission label. Note that this paragraph (b)(3) does not require engine manufacturers to take possession of the engine being replaced. Owners may arrange to keep the old engine if they demonstrate that the engine block has been destroyed. An engine block is destroyed under this paragraph (b)(3) if it can never be restored to a running configuration.

* * * * *

(c) * * *

(3) * * *

(ii) Count exempt engines as tracked under paragraph (b) of this section only if you meet all the requirements and conditions that apply under paragraph (b)(2) of this section by

the due date for the annual report. In the annual report you must identify any replaced engines from the previous year ~~that you were not able to recover~~ whose final disposition is not resolved by the due date for the annual report. Continue to report those engines in later reports until the final disposition is resolved~~you recover the replaced engines~~. If the final disposition of any replaced engine is not ~~recovered~~ resolved for the fifth annual report following the production report, treat this as an untracked replacement in the fifth annual report for the preceding year.

* * * * *

267.268. Amend §1068.261 by revising paragraphs (b), (c) introductory text, and (d) introductory text to read as follows:

§1068.261 Delegated assembly and other provisions related to engines not yet in the certified configuration.

* * * * *

(b) If you manufacture engines and install them in equipment you or an affiliated company also produce, you must take steps to ensure that your facilities, procedures, and production records are set up to ensure that equipment and engines are assembled in their proper certified configurations. For example, you may demonstrate compliance with the requirements of this section by maintaining a database showing how you pair aftertreatment components with the appropriate engines such that the final product is in its certified configuration.

(c) If you manufacture engines and ship them to an unaffiliated company for installation in equipment and you include the price of all aftertreatment components in the price of the engine ~~and (whether or not you ship the aftertreatment components directly to the equipment manufacturer), or arrange for separate shipment by the component manufacturer to the equipment manufacturer,~~ all the following conditions apply:

* * * * *

(d) If you manufacture engines and ship them to an unaffiliated company for installation in equipment, but you do not include the price of all aftertreatment components in the price of the engine, you must meet all the conditions described in paragraphs (c)(1) through (9) of this section, with the following additional provisions:

* * * * *

268.269. Amend §1068.301 by revising paragraph (b) to read as follows:

§1068.301 General provisions for importing engines/equipment.

* * * * *

(b) In general, engines/equipment that you import must be covered by a certificate of conformity unless they were built before emission standards started to apply. This subpart describes the limited cases where we allow importation of exempt or excluded engines/equipment. If an engine has an exemption from exhaust emission standards, ~~this allows you may to~~ import the equipment under the same exemption. Imported engines/equipment that are exempt or excluded must have a label as described in the specific exemption or exclusion. If the regulation does not include specific labeling requirements, apply a label meeting the requirements of §1068.45 that identifies your corporate name and describes the basis for the exemption or exclusion.

* * * * *

~~269-270.~~ Amend §1068.310 by revising the introductory text and paragraph (e)(4) to read as follows:

§1068.310 Exclusions for imported engines/equipment.

If you show us that your engines/equipment qualify under one of the paragraphs of this section, we will approve your request to import such excluded engines/equipment. You must have our approval before importing engines/equipment under paragraph (a) of this section. You may, but are not required to request our approval to import the engines/equipment under paragraph (b) through (d) of this section. The following Qualifying engines/equipment are excluded as follows:

* * * * *

(e) * * *

(4) State: “THIS ENGINE IS EXEMPT FROM THE REQUIREMENTS OF [identify the part referenced in §1068.1(a) that would otherwise apply], AS PROVIDED IN [identify the paragraph authorizing the exemption (for example, “40 CFR 1068.310~~315~~(a)”)]. INSTALLING THIS ENGINE IN ANY DIFFERENT APPLICATION MAY BE A VIOLATION OF FEDERAL LAW SUBJECT TO CIVIL PENALTY.”

~~270-271.~~ Amend §1068.315 by revising paragraphs (a) and (h) and removing paragraph (i) to read as follows:

§1068.315 Permanent exemptions for imported engines/equipment.

* * * * *

(a) *National security exemption.* You may import an engine or piece of equipment under the national security exemption in §1068.225, ~~but only if it is properly labeled.~~

* * * * *

(h) *Identical configuration exemption.* Unless specified otherwise in the standard-setting part, you may import nonconforming engines/equipment if they are identical in all material respects to certified engines/equipment produced by the same manufacturer, subject to the following provisions:

(1) You must meet all the following criteria:

(i) You have owned the engines/equipment for at least six months.

(ii) You agree not to sell, lease, donate, trade, or otherwise transfer ownership of the engines/equipment for at least five years. During this period, the only acceptable way to dispose of the engines/equipment during this five-year period is to destroy or export them.

(iii) You use data or evidence sufficient to show that the engines/equipment are in a configuration that is identical in all material respects to engines/equipment the original manufacturer has certified to meet emission standards that apply at the time the manufacturer finished assembling or modifying the engines/equipment in question. If you modify the engines/equipment to make them identical, you must completely follow the original manufacturer’s written instructions.

(2) We will tell you in writing if we find the information insufficient to show that the engines/equipment are eligible for this the identical configuration exemption. ~~In this case,~~ We will then not consider your request further until you address our concerns.

~~271-272.~~ Amend §1068.325 by revising the introductory text and paragraphs (a)-(c), (e), and (g) to read as follows:

§1068.325 Temporary exemptions for imported engines/equipment.

You may import engines/equipment under certain temporary exemptions, subject to the conditions in this section. We may ask U.S. Customs and Border Protection to require a specific bond amount to make sure you comply with the requirements of this subpart. You may not sell or lease one of these ~~exempted~~ engines/equipment while it is in the United States except as specified in this section or §1068.201(i). You must eventually export the engine/equipment as we describe in this section unless it conforms to a certificate of conformity or it qualifies for one of the permanent exemptions in §1068.315 or the standard-setting part.

(a) *Exemption for repairs or alterations.* You may temporarily import nonconforming engines/equipment ~~under bond~~ solely for repair or alteration, subject to our advance approval as described in paragraph (j) of this section. You may operate the engine/equipment in the United States only as necessary to repair it, alter it, or ship it to or from the service location. Export the engine/equipment directly after servicing is complete, or confirm that it has been destroyed.

(b) *Testing exemption.* You may temporarily import nonconforming engines/equipment ~~under bond~~ for testing if you follow the requirements of §1068.210, subject to our advance approval as described in paragraph (j) of this section. You may operate the engines/equipment in the United States only as needed to perform tests. ~~The testing This~~ exemption expires one year after you import the engine/equipment unless we approve an extension. The engine/equipment must be exported before the exemption expires. You may sell or lease the engines/equipment consistent with the provisions of §1068.210.

(c) *Display exemption.* You may temporarily import nonconforming engines/equipment ~~under bond~~ for display if you follow the requirements of § 1068.220, subject to our advance approval as described in paragraph (j) of this section. ~~The display This~~ exemption expires one year after you import the engine/equipment, unless we approve your request for an extension. The engine/equipment must be exported (or destroyed) by the time the exemption expires or directly after the display concludes, whichever comes first.

* * * * *

(e) *Diplomatic or military exemption.* You may temporarily import nonconforming engines/equipment ~~without bond~~ if you represent a foreign government in a diplomatic or military capacity. ~~U.S Customs and Border Protection may require that you show your In your request to the Designated Compliance Officer (see §1068.305), include either~~ written confirmation from the U.S. State Department that you qualify for ~~the diplomatic or military this~~ exemption or a copy of your orders for military duty in the United States. We will rely on the State Department or your military orders to determine when your diplomatic or military status expires, at which time you must export your exempt engines/equipment.

* * * * *

(g) *Exemption for partially complete engines.* ~~The following provisions apply for importing partially complete engines and used engines that become new as a result of importation:~~

~~(1) You may import a partially complete engine by shipping it from one of your facilities to another under the provisions of §1068.260(c) if you also apply a removable label meeting the requirements of §1068.45 that identifies your corporate name and states that the engine is exempt under the provisions of §1068.325(g).~~

~~(2) You may import an engine if another company already has a certificate of conformity and will be modifying the engine to be in its final certified configuration or a final exempt configuration if you meet the labeling and other requirements under the provisions of~~

§1068.262. ~~You may also import a partially complete engine by shipping it from one of your facilities to another under the provisions of §1068.260(e).~~ If you are importing a used engine that becomes new as a result of importation, you must meet all the requirements that apply to original engine manufacturers under §1068.262. You may sell or lease the engines consistent with the provisions of §1068.262.

* * * * *

~~272.273.~~ Amend §1068.450 by revising paragraph (e) to read as follows:

§1068.450 What records must I send to EPA?

* * * * *

(e) We may post test results on publicly accessible databases and we will send copies of your reports to anyone from the public who asks for them, consistent with §1068.11. ~~We will not release information about your sales or production volumes, which is all we will consider confidential.~~

~~273.274.~~ Amend §1068.601 by revising the introductory text and paragraph (b) to read as follows:

§ 1068.601 Overview.

The regulations of this chapter involve numerous provisions that may result in EPA making a decision or judgment that you may consider adverse to your interests. For example, our decisions might require you to pay penalties, or you might consider that our decisions will ~~and that either limits your business activities or put you at a competitive disadvantage or requires you to pay penalties.~~ As specified in the regulations in this chapter, this might involve an opportunity for an informal hearing or a formal hearing that follows specific procedures and is directed by a Presiding Officer. The regulations in this chapter generally specify when we would hold a hearing. In limited circumstances, we may grant a request for a hearing related to adverse decisions regarding regulatory provisions for which we do not specifically describe the possibility of asking for a hearing.

* * * * *

(b) For other issues where the regulation allows for a hearing in response to an adverse decision, you may request an informal hearing as described in § 1068.650. Sections 1068.610 through 1068. ~~630~~625 describe when and how to request an informal hearing under various circumstances.

* * * * *

~~274.275.~~ Add §1068.630 to read as follows:

§ 1068.630 Request for hearing – allowable maintenance.

(a) Any manufacturer may request an informal hearing as described in § 1068.50 in response to our decision to identify allowable maintenance associated with new technology as part of the certification process.

(b) You must send your hearing request in writing to the Designated Compliance Officer no later than 30 days after we publish our decision in the *Federal Register*. If the deadline passes, we may nevertheless grant you a hearing at our discretion.

(c) Your hearing request must include the information specified in § 1068.610(d).

(d) We will approve your request for an informal hearing if we find that your request raises a substantial factual issue in the decision we made that, if addressed differently, could alter the outcome of that decision.

~~275.276.~~ Redesignate appendix I to part 1068 as appendix A to part 1068 and amend the redesignated appendix A by revising the introductory text to read as follows:

Appendix ~~I~~A to Part 1068 – Emission-Related Components

This appendix specifies emission-related components that we refer to for describing such things as emission-related warranty or maintenance or requirements related to rebuilding engines. Note that inclusion of a component in Section III of this Appendix does not make it an emission-related component for engines/equipment that are not subject to evaporative emission standards.

* * * * *

Appendix II to Part 1068—[Redesignated as Appendix B to Part 1068]

~~276.277.~~ Redesignate appendix II to part 1068 as appendix B to part 1068.

Appendix III to Part 1068—[Redesignated as Appendix C to Part 1068]

~~277.278.~~ Redesignate appendix III to part 1068 as appendix C to part 1068.

PART 1090—REGULATION OF FUELS, FUEL ADDITIVES, AND REGULATED BLENDSTOCKS

~~278.~~279. The authority citation for part 1090 continues to read as follows:
Authority: 42 U.S.C. 7414, 7521, 7522-7525, 7541, 7542, 7543, 7545, 7547, 7550, and 7601.

~~279.~~280. Revise §1090.1550 to read as follows:

§ 1090.1550 Requirements for gasoline dispensing nozzles used with motor vehicles.

~~(a)~~ The following requirements ~~refueling hardware specifications~~ apply for any nozzle installation used for dispensing gasoline into motor vehicles:

(a) Nozzles must meet the following hardware specifications:

- (1) The outside diameter of the terminal end must not be greater than 21.3 mm.
- (2) The terminal end must have a straight section of at least 63 mm.
- (3) The retaining spring must terminate at least 76 mm from the terminal end.

~~(b) For nozzles that dispense gasoline into motor vehicles,~~ The dispensing flow rate must not exceed a maximum value of 10 gallons per minute. The flow rate may be controlled through any means in the pump/dispenser system, as long as it does not exceed the specified maximum value. ~~Any dispensing pump dedicated to heavy-duty vehicles or airplanes is exempt from this flow-rate requirement.~~