

For assistance in accessing this document, please contact ghgreporting@epa.gov.



| | | | |
|---|-------------------------------------|------------------------|------------------------|
| Monitoring, Reporting, and Verification Plan CCS#2 | | | |
| Date Issued 3/21/2024 | Document # 180.60.ENV.309 | Version 10.0 | Page 1 of 37 |

LIST OF CONTROLLED COPIES, LOCATION, AND RESPONSIBILITY:

| Copy # | Location | Responsibility |
|----------|---------------------|-----------------------|
| Original | DCS/DMS – (180-SQL) | Environmental Manager |

APPROVALS:

- Plant Manager
- Environmental Manager

SUMMARY OF CURRENT REVISION:

| Date | Version | Author | Reason(s) for revision |
|-----------|---------|----------------------------------|--|
| 3/20/2024 | 10.0 | D. Maity/M. Khan/ K. Davis | Updated section 10.4 to discuss repeat seismic survey (2021). Minor language edits. |



| | | | |
|---|-------------------------------------|------------------------|------------------------|
| Monitoring, Reporting, and Verification Plan CCS#2 | | | |
| Date Issued 3/21/2024 | Document # 180.60.ENV.309 | Version 10.0 | Page 2 of 37 |

CONTENTS

1.0 PURPOSE 4

2.0 SCOPE..... 4

3.0 DEFINITIONS..... 6

4.0 PRINCIPLE..... 6

5.0 SAFETY..... 6

6.0 PROJECT DESCRIPTION..... 6

7.0 DELINEATION OF MONITORING AREAS 11

8.0 EVALUATION OF LEAKAGE PATHWAYS..... 14

 8.1 Leakage from Surface Components 14

 8.2 Leakage through Abandoned Oil & Gas Wells 15

 8.3 Leakage through Fractures, Faults, and Bedding Plane Partings..... 15

 8.4 Leakage through Confining Zone Limitations 16

 8.5 Leakage through Injection or Monitoring Wells 16

9.0 DETECTION, VERIFICATION, AND QUANTIFICATION OF LEAKAGE 18

 9.1 Leakage Detection..... 18

 9.1.1 Surface Leakage Detection 19

 9.1.2 Subsurface Leakage Detection..... 19

 9.1.2.1 Injection Well Monitoring and MIT 20

 9.2 Leakage Verification 25

 9.2.1 Surface Leakage 25

 9.2.2 Subsurface Leakage 25

 9.3 Leakage Quantification 26

 9.3.1 Surface Leakage 26

 9.3.2 Subsurface Leakage 27

 9.3.3 Leakage Emitted to Surface 28

10.0 DETERMINATION OF EXPECTED BASELINES 28

 10.1 Injection Well Monitoring 28



| | | | |
|---|-------------------------------------|------------------------|------------------------|
| Monitoring, Reporting, and Verification Plan CCS#2 | | | |
| Date Issued 3/21/2024 | Document # 180.60.ENV.309 | Version 10.0 | Page 3 of 37 |

10.2 Groundwater Quality and Geochemical Change Monitoring..... 29

10.3 Mechanical Integrity Testing 30

10.4 Plume and Pressure Front Monitoring 30

11.0 SITE SPECIFIC CONSIDERATIONS FOR THE MASS BALANCE EQUATIONS 31

12.0 ESTIMATED SCHEDULE FOR IMPLEMENTATION..... 32

13.0 QUALITY ASSURANCE PROGRAM..... 32

14.0 RECORDS RETENTION 33

REFERENCE 1..... 34

REFERENCE 2..... 35

SUMMARY OF PREVIOUS REVISIONS..... 36



| Monitoring, Reporting, and Verification Plan CCS#2 | | | |
|--|----------------|---------|---------|
| Date Issued | Document # | Version | Page |
| 3/21/2024 | 180.60.ENV.309 | 10.0 | 4 of 37 |

1.0 PURPOSE

This Monitoring, Reporting, and Verification (MRV) Plan has been prepared by the Archer Daniels Midland Company (ADM) for ADM CCS#2, Permit No. IL-115-6A-0001 (CCS#2) located in Decatur, Illinois, for the United States Environmental Protection Agency (USEPA). This MRV Plan was developed in accordance with the regulations at 40 CFR 98, Subparts RR (Geologic Sequestration of Carbon Dioxide) and UU (Injection of Carbon Dioxide).

2.0 SCOPE

This procedure is applicable to:

- Archer Daniels Midland Company (ADM)
- Permit Number: IL-115-6A-0001 (UIC Class VI)
- Facility Name: CCS#2
- UNDERGROUND INJECTION CONTROL PERMIT – CLASS VI
- PERMIT NO. IL-115-6A-0001 (FACILITY NAME: CCS#2)
- Well ID Number: 12-115-23713-00

A map showing the ADM facility is provided as Figure 1.

| Monitoring, Reporting, and Verification Plan CCS#2 | | | |
|--|------------------------------|-----------------|-----------------|
| Date Issued 3/21/2024 | Document # 180.60.ENV.309 | Version 10.0 | Page 5 of 37 |



Figure 1. Site map for groundwater compliance locations related to USEPA UIC Permits IL-115-6A-0001 and IL-115-6A-0002.



| Monitoring, Reporting, and Verification Plan CCS#2 | | | |
|--|----------------|---------|---------|
| Date Issued | Document # | Version | Page |
| 3/21/2024 | 180.60.ENV.309 | 10.0 | 6 of 37 |

3.0 DEFINITIONS

None

4.0 PRINCIPLE

None

5.0 SAFETY

There are no specific safety guidelines associated with this procedure.

6.0 PROJECT DESCRIPTION

ADM will capture carbon dioxide gas from their fuel ethanol production unit and compress the gas into a dense-phase liquid for injection into the Mt. Simon Sandstone approximately 7,000 feet below the ground surface. The injection zone is overlain by the Cambrian Eau Claire Formation, which acts as the seal, and is underlain by Precambrian granitic basement (Figure 2). The lower section of the Mt. Simon is the principal target reservoir and is an arkosic sandstone that was originally deposited in a braided river – alluvial fan system. The lowermost USDW at the CCS#2 injection site is the Pennsylvanian bedrock.

ADM’s Decatur facility houses two geologic carbon sequestration projects. The Illinois State Geological Survey (ISGS) managed the Illinois Basin Decatur Project (IBDP) at the Archer Daniels Midland, CCS#1 Well (Permit No. IL-115-6A-0002), which completed its goal of injecting 1 million metric tons of CO₂ over a three-year period from November 2011 to November 2014. The project covered by this MRV plan is identified as the Illinois Industrial Carbon Capture and Sequestration (IL-ICCS) project. The IL-ICCS project is the second carbon sequestration project at the Decatur facility, CCS#2 (Permit No. IL-115-6A-0001).

The IL-ICCS project plans to inject up to 3,300 metric tons of carbon dioxide (CO₂) daily, or 6 million metric tons over the permitted injection period. Process flow diagrams of the CO₂ path are included in Figures 3-1 and 3-2.



| Monitoring, Reporting, and Verification Plan CCS#2 | | | |
|--|----------------|---------|---------|
| Date Issued | Document # | Version | Page |
| 3/21/2024 | 180.60.ENV.309 | 10.0 | 7 of 37 |

Further information can be found in the following documents that are referenced throughout this MRV Plan:

Reference 1 – USEPA Underground Injection Control Permit, Class VI, for ADM CCS#2, Permit No. IL-115-6A-0001, proposed modification published November 22, 2016 (as revised from time to time), permit modification effective on December 18, 2017, and permit modification effective December 20, 2021, including Attachments A, B, C (with Quality Assurance & Surveillance Plan), D, E, F, G, H, and I.

Reference 2 – ADM Permit Application for Underground Injection Control Permit, July 2011, including Appendices A-H (Permit Application).

| | | | |
|---|-------------------------------------|------------------------|------------------------|
| Monitoring, Reporting, and Verification Plan CCS#2 | | | |
| Date Issued 3/21/2024 | Document # 180.60.ENV.309 | Version 10.0 | Page 8 of 37 |

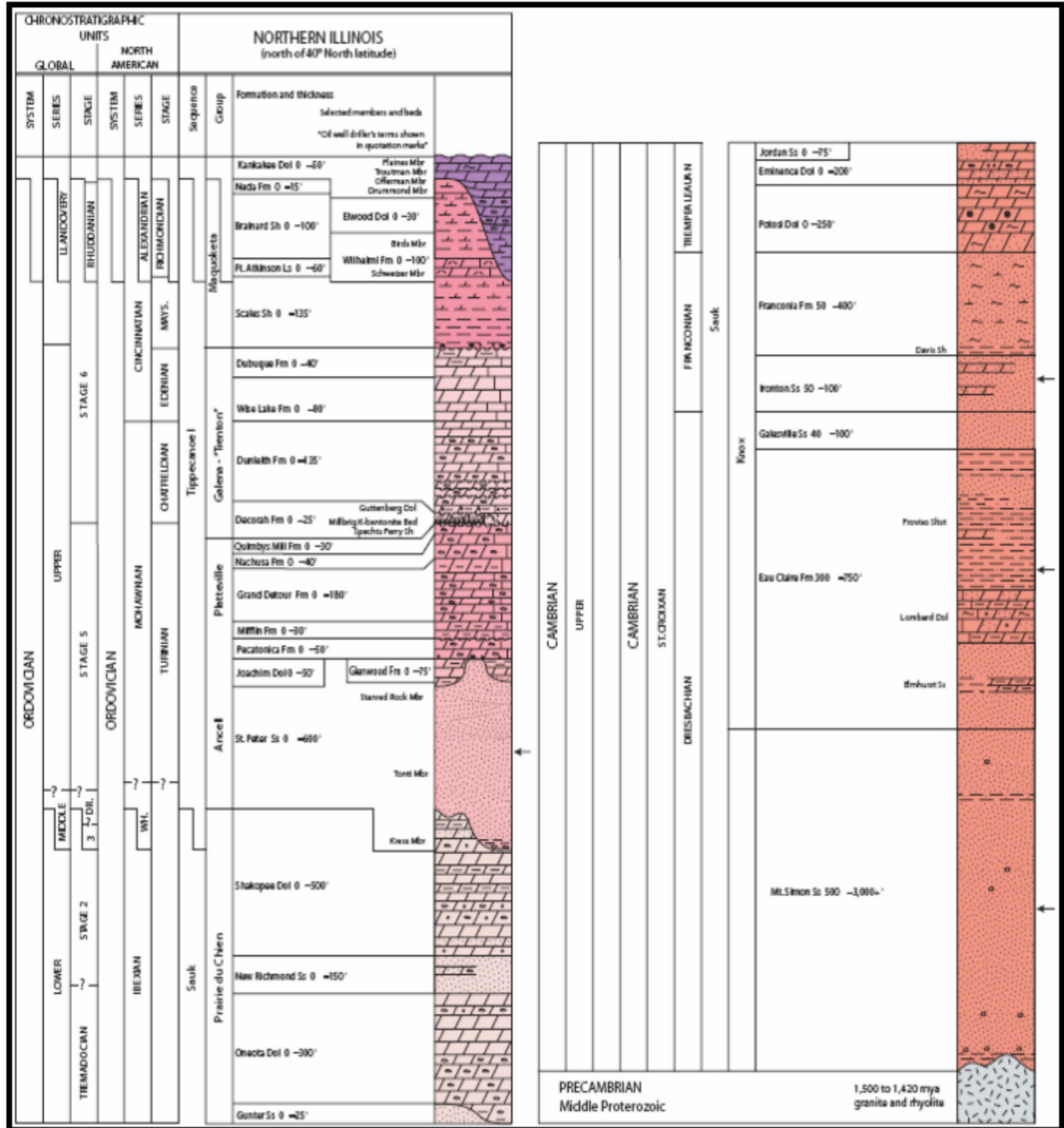

Figure 2. Stratigraphic column of Ordovician through Precambrian rocks in northern Illinois (Kolata, 2005).

| | | |
|---|-------------------------------------|-------------------------|
| Monitoring, Reporting, and Verification Plan CCS#2 | | |
| Date Issued 3/21/2024 | Document # 180.60.ENV.309 | Version 10.0 |
| | | Page 10 of 37 |

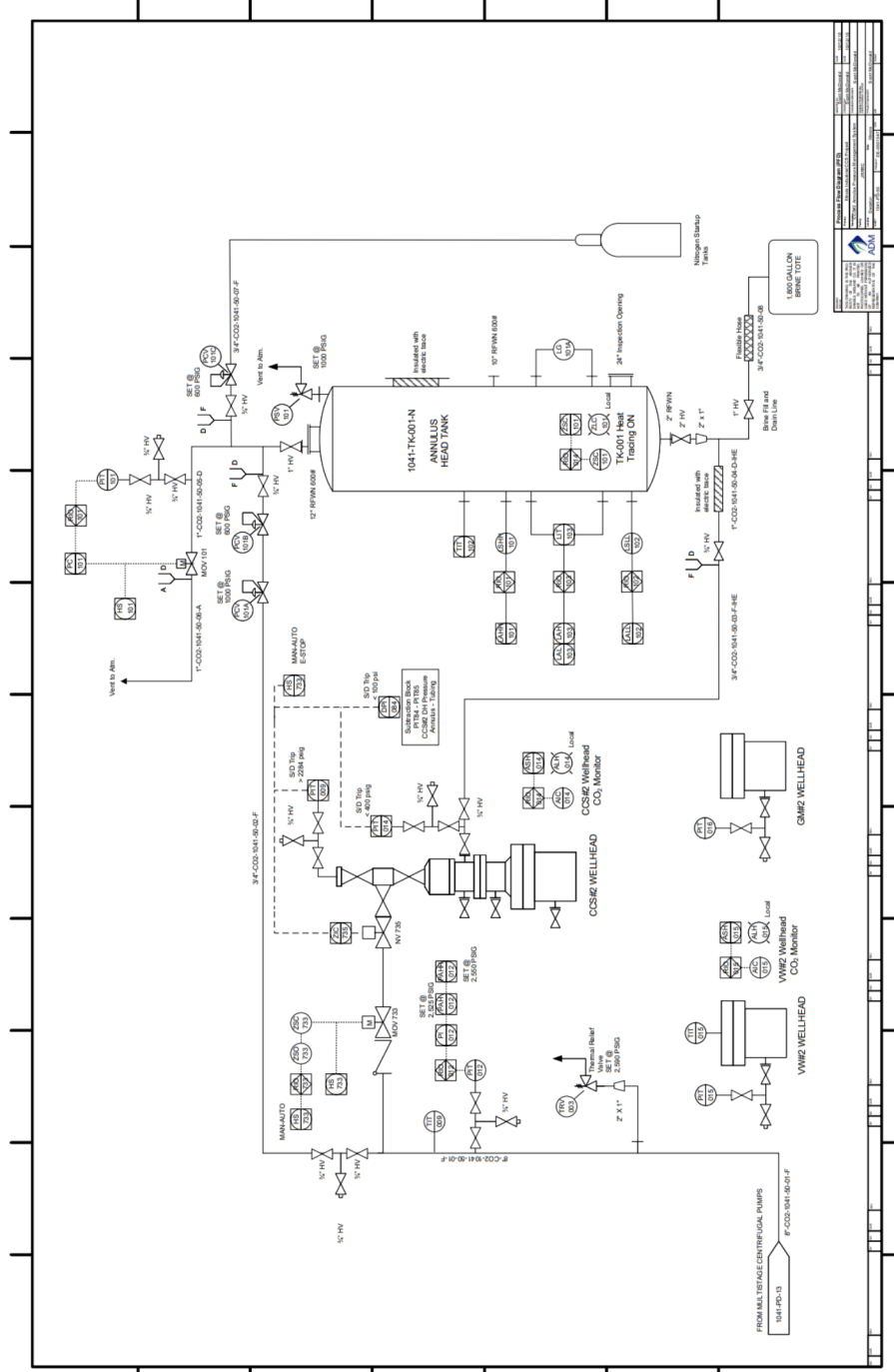

Figure 3-2. Process flow diagram demonstrating CO2 flow path at the CCS#2 wellhead.



| Monitoring, Reporting, and Verification Plan CCS#2 | | | |
|--|------------------------------|-----------------|------------------|
| Date Issued 3/21/2024 | Document # 180.60.ENV.309 | Version 10.0 | Page 11 of 37 |

7.0 DELINEATION OF MONITORING AREAS

The area to be monitored is the Area of Review (AOR) identified in Reference 1, Section G and Attachment B. Based on the predicted area of the CO₂ plume as estimated using the reservoir flow model, ADM will use the AOR as shown in Reference 1, Attachment B, Figure 7, plus a one-half mile buffer, as the maximum monitoring area (MMA) shown in Figure 4.

The active monitoring area (AMA) is defined in 40 CFR 98.449 as “the area that will be monitored over a specific time interval from the first year of the period (n) to the last year in the period (t). The boundary of the active monitoring area is established by superimposing two areas: (1) The area projected to contain the free phase CO₂ plume at the end of year t, plus an all-around buffer zone of one-half mile or greater if known leakage pathways extend laterally more than one-half mile; (2) The area projected to contain the free phase CO₂ plume at the end of year t+5.” The maximum monitoring area (MMA) is defined in 40 CFR 98.449 as “the area that must be monitored under this regulation and is defined as equal to or greater than the area expected to contain the free phase CO₂ plume until the CO₂ plume has stabilized plus an all-around buffer zone of at least one-half mile.” ADM considers the AMA and MMA as the same under the Permit No. IL-115-6A-0001.

For CCS#2, the AMA will remain constant throughout the injection period and the 10-year post-injection site care (PISC) period. If n is 1 year (beginning of injection period) and t is when 6.5 million Mt have been injected (10 years), the AMA would be the area of the stabilized CO₂ plume plus a half mile buffer (MMA) because the plume was modeled to stabilize 4 years post injection (Reference 1, Section 9.1.3). The t+5 boundary will be contained within the stabilized plume and half mile buffer boundary making the AMA the same area as the MMA. The AMA under the Permit No. IL-115-6A-0001 will consist of the AOR as shown in Attachment B of Reference 1, and Figure 4 shows the extent of the AMA and MMA.

The AMA will incorporate, as described in the Testing and Monitoring Plan (Reference 1, Attachment C):

- Continuous monitoring of injection pressure, annulus pressure, and temperature monitoring at the injection well;



| Monitoring, Reporting, and Verification Plan CCS#2 | | | |
|--|----------------|---------|----------|
| Date Issued | Document # | Version | Page |
| 3/21/2024 | 180.60.ENV.309 | 10.0 | 12 of 37 |

- Groundwater quality monitoring in the local drinking water strata, the lowermost underground source of drinking water (USDW), and the strata immediately above the Eau Claire confining zone;
- External mechanical integrity testing (MIT) and pressure fall-off testing at the injection well;
- Plume and pressure front monitoring in the Mt. Simon using direct and indirect methods (i.e., brine geochemical monitoring, pulse neutron logs, seismic surveys).

| | | | |
|--|------------------------------|-----------------|------------------|
| Monitoring, Reporting, and Verification Plan CCS#2 | | | |
| Date Issued 3/21/2024 | Document # 180.60.ENV.309 | Version 10.0 | Page 13 of 37 |

Maximum Monitoring Area Delineation



Figure 4. Maximum Monitoring Area (MMA) is defined by the stabilized CO₂ plume (blue) plus a half mile buffer zone (pink circle). The Active Monitoring Area (AMA) is the same as the MMA as described above.



| | | | |
|---|-------------------------------------|------------------------|-------------------------|
| Monitoring, Reporting, and Verification Plan CCS#2 | | | |
| Date Issued 3/21/2024 | Document # 180.60.ENV.309 | Version 10.0 | Page 14 of 37 |

8.0 EVALUATION OF LEAKAGE PATHWAYS

ADM has defined the potential leakage pathways within the AOR as

1. Leakage from surface components (pipeline and wellhead).
2. Leakage through abandoned oil & gas wells.
3. Leakage through fractures, faults, and bedding plane partings.
4. Leakage through confining zone limitations.
5. Leakage through injection well or monitoring wells.

A qualitative evaluation of each of the potential leakage pathways is described in the below paragraphs. Risk estimates utilize the qualitative descriptions found in the geosphere risk assessment described for the Weyburn CO₂ storage site in Canada¹.

8.1 Leakage from Surface Components

The most probable potential for leakage of CO₂ to the surface is from surface components of the injection system: the pipeline that transports CO₂ to the injection well (approximately 5,000 feet in length), and the wellhead itself. Leakage is most likely to be the result of aging and use of the surface components over time, most likely at flanged connection points. Leakage could also occur as ventilation from relief valves to dissipate over-pressure in the pipeline. Additionally, leakage may occur as the result of an accident or natural disaster which damages the surface components and allows CO₂ to be released.

As a result, we conclude that the risk of leakage through this pathway is possible. The magnitude of such a leak will vary, depending on the failure mode of the component: a sudden break or rupture has the potential to allow several thousand pounds of CO₂ to be released to the atmosphere almost immediately; a slowly deteriorating seal at a flanged connection may release only a few pounds of CO₂ to the atmosphere over the course of several hours or days. Leakage or venting from surface components will be a risk only during the injection operation phase. Following the injection phase, surface components will not store or transport CO₂ and will therefore no longer be a leakage risk.

¹ "Geosphere risk assessment conducted for the IEAGHG Weyburn-Midale CO₂ Monitoring and Storage Project," Bowden, A.R., Pershke, D. F., Chalaturnyk, R. International Journal of Greenhouse Gas Control 16S (2013) S276–S290. Reference Table 4, p. S284.



| | | | |
|---|-------------------------------------|------------------------|-------------------------|
| Monitoring, Reporting, and Verification Plan CCS#2 | | | |
| Date Issued 3/21/2024 | Document # 180.60.ENV.309 | Version 10.0 | Page 15 of 37 |

8.2 Leakage through Abandoned Oil & Gas Wells

As discussed in Attachment B of Reference 1, the only wells that currently penetrate the confining zone (Eau Claire Formation) are the IBDP injection and verification wells, and the IL-ICCS injection and verification wells, all of which were constructed in accordance with UIC Class VI requirements and are actively or will be monitored for integrity on a regular basis. No other wells in the AOR have a depth greater than approximately 2,500 feet below ground surface, which is roughly 3,000 feet above the top of the injection zone (Mt. Simon Sandstone).

As a result, we conclude that the risk of leakage through this pathway is almost impossible (and should be zero) since no abandoned wells penetrate the confining zone. The magnitude and timing of such a leak are therefore not estimated.

Although leakage through abandoned wells will not occur as a primary pathway, it is possible that leakage that has migrated through the confining zone and into the more recent geologic strata may enter an abandoned well and migrate through the well to the surface; however, such leakage is expected to be detected by other monitoring methods (such as groundwater monitoring) as discussed in Section 5 of this MRV Plan.

8.3 Leakage through Fractures, Faults, and Bedding Plane Partings

As discussed in Section 2.2 of Reference 2, there are no regional faults or folds mapped within a 25-mile radius of the proposed IL-ICCS site. 2D and 3D seismic survey data collected and analyzed as part of the IBDP and IL-ICCS projects confirm the lack of significant faults or folds through the sealing formation. Also as discussed in Section 2.2 of Reference 2, the probability of an earthquake magnitude 5.0 or greater within 50 years and within 50 km is less than 1%. There is a 2% probability that the Peak Ground Acceleration due to seismic activity will exceed 10% G within 50 years. Therefore, ADM concluded the risk of a significant seismic event in the IL-ICCS project area (which could open fractures in the confining zone and overlying geologic strata and allow leakage from the injection zone) is minimal.

As a result, we conclude that the risk of leakage through this pathway is highly improbable to nearly impossible. The magnitude and timing of such a leak, if it were to occur, would be dependent on the magnitude of the seismic event. If



| Monitoring, Reporting, and Verification Plan CCS#2 | | | |
|--|------------------------------|-----------------|------------------|
| Date Issued 3/21/2024 | Document # 180.60.ENV.309 | Version 10.0 | Page 16 of 37 |

such an event were to occur during the injection period or after, it is possible that entire mass of CO₂ that was injected into the reservoir up to that time may eventually be released to the surface; the timing of such a leak would occur over the course of several months to years following the seismic event.

8.4 Leakage through Confining Zone Limitations

As discussed in Sections 2.2 to 2.5 of Reference 2, the Eau Claire Formation does not have any known penetrations (save for IBDP and IL-ICCS wells) within a 17-mile radius of the project site has a laterally extensive shale component and has only a slight dip (<1 degree). A 0.93 to 0.98 psi/ft fracture gradient was acquired from mini-frac tests. An average horizontal permeability of 0.000344 mD was acquired from 12 sidewall rotary core plugs. Additionally, the Illinois State Geological Survey database with core from the Eau Claire provided a median permeability of 0.000026 mD, and a median porosity is 4.7%. Further, 414 ft of core from a nearby (80 mile north) field was analyzed and showed vertical permeability values of <0.001 to 0.001 mD except five analyses in the range of 0.100 to 0.871 mD. This indicates that even the more permeable beds in the Eau Claire Formation are relatively tight and tend to act as sealing lithologies. The type of leakage event through a confining zone limitation is conceived as an undiscovered local anomaly in the Eau Claire Formation, small in size, which would allow CO₂ to leak through the confining zone into overlying strata.

As a result, we conclude that the risk of leakage through this pathway is highly improbable to nearly impossible. The magnitude of such a leak, if it were to occur, is likely to be very small, due to the known low permeability of the Eau Claire and the overlying secondary seal strata (Maquoketa Shale and New Albany Shale) that are also low permeability geologic units. For the same reason, it is believed that the timing of such a leak to the surface may be extremely slow (e.g., over the course of decades or longer), as the leak must pass upward through the confining zone, the secondary confining strata, and other geologic units.

8.5 Leakage through Injection or Monitoring Wells

As discussed in Sections I, K, L, and M of Reference 1 and further detailed in Attachments C (Testing and Monitoring Plan) and G (Well Construction) of Reference 1, design, construction, operation, maintenance, and monitoring plans for the injection-zone wells have been developed in accordance with UIC Class VI



| Monitoring, Reporting, and Verification Plan CCS#2 | | | |
|--|-------------------------------------|------------------------|-------------------------|
| Date Issued 3/21/2024 | Document # 180.60.ENV.309 | Version 10.0 | Page 17 of 37 |

standards to minimize the potential for loss of well integrity. Additionally, the IBDP project at the ADM Decatur facility has provided prior experience in well construction, operations and maintenance, and monitoring that has been applied in the IL-ICCS project to further reduce the risk of a leakage pathway.

As a result, we conclude that the risk of leakage through this pathway is highly improbable. If a leak were to occur through this pathway, the magnitude of the leak is likely to be on the order of several hundred to several thousand pounds of CO₂, depending on the location of the leak relative to the surface and the complexity of logistics required to seal the leak; since injection-zone wells are continuously monitored, early detection of a leak is anticipated, with appropriate mitigating measures to be implemented to minimize the mass of CO₂ leakage until remediation can be performed. The timing of CO₂ release to the surface would be dependent on the location of the leak relative to the surface, and the resulting geologic strata into which the CO₂ is released.

Table 1 and Table 2 show IL-ICCS project injection and monitoring wells, with well depth, age, and construction information.

| TABLE 1. IL-ICCS PROJECT SHALLOW WELL DATA | | | |
|--|-------------------------------------|-------------|---|
| WELL ID | DEPTH OF SCREENED INTERVAL (FT BGS) | CONSTRUCTED | CONSTRUCTION |
| G101 | 131-141 | 05/2010 | Per Illinois Dept. of Public Health regulations |
| G102 | 131-142 | 05/2010 | Per Illinois Dept. of Public Health regulations |
| G103 | 131-141 | 04/2010 | Per Illinois Dept. of Public Health regulations |
| G104 | 129-139 | 05/2010 | Per Illinois Dept. of Public Health regulations |
| MVA10LG | 92-97 | 09/2011 | Per Illinois Dept. of Public Health regulations |
| MVA11LG | 102-107 | 09/2011 | Per Illinois Dept. of Public Health regulations |
| MVA12LG | 87-92 | 09/2011 | Per Illinois Dept. of Public Health regulations |
| MVA13LG | 75-80 | 09/2011 | Per Illinois Dept. of Public Health regulations |

| TABLE 2. IL-ICCS PROJECT DEEP WELL DATA | | | |
|---|------------------|-------------|------------------------------|
| WELL ID | TOTAL DEPTH (FT) | CONSTRUCTED | CONSTRUCTION |
| CCS#1 | 7,236 feet KB | 05/2009 | Per UIC Class VI regulations |
| GM#1 | 3,496 feet KB | 11/2009 | Per UIC Class VI regulations |
| VW#1 | 7,272 feet KB | 11/2010 | Per UIC Class VI regulations |
| CCS#2 | 7,236 feet KB | 05/2015 | Per UIC Class VI regulations |
| GM#2 | 3,552 feet KB | 11/2012 | Per UIC Class VI regulations |
| VW#2 | 7,227 feet KB | 11/2012 | Per UIC Class VI regulations |



| | | | |
|---|-------------------------------------|------------------------|-------------------------|
| Monitoring, Reporting, and Verification Plan CCS#2 | | | |
| Date Issued 3/21/2024 | Document # 180.60.ENV.309 | Version 10.0 | Page 18 of 37 |

9.0 DETECTION, VERIFICATION, AND QUANTIFICATION OF LEAKAGE

9.1 Leakage Detection

Leakage detection for the IL-ICCS project will incorporate several monitoring programs: visual inspection of the pipeline to the injection well, injection well monitoring and MIT, CO₂ plume / pressure front monitoring, and groundwater quality monitoring. Table 3 provides general information on the leakage pathways, monitoring programs to detect such leakage, spatial coverage of the monitoring program, and the monitoring timeline. Further details are provided in Reference 1, Attachment C (Testing and Monitoring Plan).

| TABLE 3. LEAKAGE DETECTION MONITORING | | | |
|--|-------------------------------------|--|--|
| Leakage Pathway | Detection Monitoring Program | Spatial Coverage of Monitoring Program | Monitoring Timeline |
| Surface Components | Visual Inspection | From flow meter to injection wellhead | Monthly for duration of injection |
| | Injection Well Monitoring & MIT | Injection well (from surface to injection formation) | For duration of injection |
| Abandoned Oil & Gas Wells | Plume / Pressure Front Monitoring | From injection wellhead to edge of AMA | For duration of injection; and in Years 1 and 10 following injection |
| | Groundwater Quality Monitoring | Groundwater monitoring locations | Quarterly to annual during injection |
| Fractures & Faults | Plume / Pressure Front Monitoring | From injection wellhead to edge of AMA | For duration of injection; and in Years 1 and 10 following injection |
| | Groundwater Quality Monitoring | Groundwater monitoring locations | Quarterly to annual during injection |
| Confining Zone Limitations | Plume / Pressure Front Monitoring | From injection wellhead to edge of AMA | For duration of injection; and in Years 1 and 10 following injection |
| | Groundwater Quality Monitoring | Groundwater monitoring locations | Quarterly to annual during injection |
| Injection or Monitoring Wells | Injection Well Monitoring & MIT | Injection well (from surface to injection formation) | For duration of injection |



| Monitoring, Reporting, and Verification Plan CCS#2 | | | |
|--|----------------|---------|----------|
| Date Issued | Document # | Version | Page |
| 3/21/2024 | 180.60.ENV.309 | 10.0 | 19 of 37 |

9.1.1 Surface Leakage Detection

Controlled or planned emissions from maintenance would occur when a section of a pipe containing CO₂ is isolated and vented so that a part can be maintained or repaired. Examples include replacement of instruments and valves as well as replacement of gaskets in the event of a leaking flange. Planned emissions due to maintenance will be limited to the extent possible. Controlled emissions will be tracked and reported as “leakage” (as the CO₂ will be vented rather than injected).

Unintentional (fugitive) emissions could arise from leakage of CO₂ at flanges and seals, at defects or cracks in the casing wall, or at pressure relief valves along the pipeline. Leakage from the pipeline or wellhead would be detected visually by ice crystal formation (due to the temperature reduction associated with release of supercritical CO₂ to the atmosphere) around the leakage point. Visual monitoring for these emissions will be performed monthly to detect fugitive emissions.

Visual inspection will not be possible for the single segment of the pipeline that is underground. This section of the pipeline is 100% welded with no valves or flanges that could act as a leakage source; therefore, the potential for leakage in this segment is very low. Leak detection for this segment of pipeline would be limited to observation of abnormal pressure drops during a period of well shut-in and there is an absence of leakage detected in the aboveground pipeline. Well shut-in may be planned to occur on an annual basis for testing and/or maintenance activities or other activities required by the permit.

9.1.2 Subsurface Leakage Detection

Leakage from the subsurface would be detected by one or more of the monitoring systems in the form of multiple measurements that are outside of the statistical baseline values (see Section 10,) are persistent over a time period (i.e., not a one-time anomalous measurement), and cannot be explained by a variation in injection operations or unanticipated conditions in the injection formation.

In all cases where monitoring data suggests a leak, data verification procedures will be followed as outlined in the Quality Assurance and



| Monitoring, Reporting, and Verification Plan CCS#2 | | | |
|--|------------------------------|-----------------|------------------|
| Date Issued 3/21/2024 | Document # 180.60.ENV.309 | Version 10.0 | Page 20 of 37 |

Surveillance Plan (QASP, located in Reference 1, Attachment C, Appendix A). Data verification efforts should eliminate the possibility that a “false positive” leak detection occurs.

9.1.2.1 Injection Well Monitoring and MIT

Injection well monitoring will include pressure and temperature monitoring, and the use of one or more approved methods for MIT as described in the Final Permit (Reference 1). The injection well monitoring methods are briefly described below; further information on testing and monitoring procedures can be found in Reference 1, Attachment C.

1. Injection Well Pressure and Temperature. Pressure and temperature will be continuously monitored during injection operations, at the surface (wellhead), at the injection zone, and in the well annulus. Anomalous measurements will trigger further investigation, and if not attributable to operational or injection zone conditions, such measurements could indicate CO₂ leakage.
2. Wireline Temperature Log. Temperature data will be recorded across the wellbore from surface down to the primary caprock. Bottom hole pressure data near the packer will also be provided.

Data interpretation involves comparing the time lapse well temperature profiles and looking for temperature anomalies that may indicate a failure in well integrity, i.e., tubing leak or movement of fluid behind the casing. As the well cools down, the temperature profile along the length of the tubing string is compared to the baseline. Any unplanned fluid movement into the annulus or outside the casing creates a temperature anomaly when compared to the baseline cooling profile.

3. Temperature Log using Distributed Temperature Sensing (DTS). CCS#2 is equipped with a DTS fiber optic temperature monitoring system that is capable of monitoring the injection well’s annular temperature along the length of the tubing string. The DTS line is used for real time temperature monitoring and, like a conventional temperature log, can be used for early detection of temperature changes that may indicate a loss of well mechanical integrity.



| Monitoring, Reporting, and Verification Plan CCS#2 | | | |
|--|-------------------------------------|------------------------|-------------------------|
| Date Issued 3/21/2024 | Document # 180.60.ENV.309 | Version 10.0 | Page 21 of 37 |

Data interpretation involves comparing the time lapse well temperature profiles and looking for temperature anomalies that may indicate a failure of well integrity; i.e. tubing leak or movement of fluid behind the casing. The DTS system monitors and records the well’s temperature profiles at a pre-set frequency in real time. As the well cools down, the temperature profile along the length of the tubing string is compared to the baseline. Any unplanned fluid movement into the annulus or outside the casing creates a temperature anomaly when compared to the baseline cooling profile. This data can be continuously monitored to provide real time MIT surveillance.

4. Pulse Neutron Logging. Logging data will be recorded across the wellbore from the surface down to the primary caprock.

Data analysis will identify the mobilization of CO₂ or differences in the salinity of the reservoir fluids in the observation zone above the Eau Claire Shale seal. Differences between the measured and baseline value(s) may indicate the movement of fluids in the annulus or behind the casing.

9.1.2.2 Groundwater Quality and Geochemical Monitoring

The groundwater quality monitoring network, which includes both injection-zone monitoring and monitoring above the primary confining zone, is designed to detect unforeseen leakage from the Mt. Simon as soon after the first occurrence as possible.

Three aquifers above the primary confining zone are monitored for any unforeseen leakage of CO₂ and/or brine out of the injection zone. These include the aquifer immediately above the confining zone (Ironton/Galesville Sandstone), the St. Peter Sandstone, which is considered to be the lowermost USDW at the site (direct monitoring of the lowermost USDW aquifer is required by the EPA’s UIC Program for CO₂ geologic sequestration), and the local source of drinking water, Quaternary / Pennsylvania strata (shallow groundwater). Shallow groundwater samples will be collected on a quarterly basis in years 1-2 of injection, semi-annual sampling for years 3-5 of injection, and annual sampling during post-injection. Deep groundwater quality samples will be collected



| Monitoring, Reporting, and Verification Plan CCS#2 | | | |
|--|-------------------------------------|------------------------|-------------------------|
| Date Issued 3/21/2024 | Document # 180.60.ENV.309 | Version 10.0 | Page 22 of 37 |

on an annual basis (see Reference 1, Attachment C for further detail on monitoring frequency).

In addition to direct monitoring specifically for the presence of CO₂, wells monitoring the deeper formations (St. Peter and Ironton/Galesville) are monitored for changes in geochemical and isotopic signatures that provide indication of CO₂ and/or brine leakage.

9.1.2.3 Plume and Pressure Front Monitoring

Direct and indirect methods will be utilized to monitor the CO₂ plume and pressure front. The plume will be directly monitored via annual fluid sampling in the Mt. Simon using VW#2 and/or other nearby monitoring wells. Indirect monitoring will consist of pulse neutron logging / reservoir saturation testing in VW#1, VW#2, CCS#1, and CCS#2 every two years during the injection phase, and seismic surveys / monitoring (reference Attachment C of Reference 1 for details).

Time lapse-vertical seismic profile (VSP) surveys were conducted annually using GM#1 in 2013, 2014, and 2015. The extent of the VSP survey is limited to approximately 30 acres in the vicinity of CCS #1. A baseline 3D seismic survey was conducted over the full AOR in January 2011, and a subsequent 3D survey was conducted after the completion of the IBDP’s injection period in January 2015. These 3D surveys extended roughly 3,000 acres centered near the location of CCS#2 and provided fold image coverage of roughly 2,000 acres.

Reduced-scale 3D surveys (roughly 2,000 acres, with fold image coverage of roughly 650 acres) with a focus on the vicinity north of CCS#2 were conducted in 2021, and another is planned for year 10 following the conclusion of injection operations (approximately 2030).

Based on prior seismic survey data interpretations, we have not detected any major faults or fractures in the subsurface strata that may indicate potential leakage pathways. Future surveys will be monitored to predict the potential for leakage and will provide information on the extent of the CO₂ plume within the Mt. Simon.



| | | | |
|---|-------------------------------------|------------------------|-------------------------|
| Monitoring, Reporting, and Verification Plan CCS#2 | | | |
| Date Issued 3/21/2024 | Document # 180.60.ENV.309 | Version 10.0 | Page 23 of 37 |

Additionally, ADM will maintain a network of seismic monitoring stations to detect natural or induced seismic events greater than magnitude 1.0 (M1.0) within an 8-mile radius of the CCS#2 site, which could indicate activation of pre-existing planes of weakness (faults) that could compromise the seal formation. As mentioned in Section 8.3, the risk of a seismic event occurring is deemed as very low for the area surrounding the ADM facility. If any seismic event greater than M1.0 were to occur, a risk assessment and response plan will be put into effect based on the ADM Decatur Seismic Monitoring System as defined in Table 4.

| TABLE 4. ADM DECATUR SEISMIC MONITORING SYSTEM ⁽¹⁾ | | |
|--|---|---|
| Operating State | Threshold Condition | Response Action |
| Green | Seismic events less than or equal to M1.5 ⁽²⁾ | 1. Continue normal operation within permitted levels. |
| Yellow | Five (5) or more seismic events within a 30-day period having a magnitude greater than M1.5 ⁽²⁾ but less than or equal to M2.0 ⁽²⁾ . | 1. Continue normal operation within permitted levels. 2. Within 24 hours of the incident, notify the UIC Program Director and ISGS of the operating status of the well. |
| Orange | Seismic event greater than M1.5 (2); and Local observation or felt report ⁽³⁾ Or Seismic event greater than M2.0 ⁽²⁾ and no felt report | 1. Continue normal operation within permitted levels. 2. Within 24 hours of the incident, notify the UIC Program Director, ISGS, and ADM Communications of the operating status of the well. 3. Review seismic and operational data. 4. Report findings to the UIC Program Director and issue corrective actions ⁽⁵⁾ . |
| Magenta | Seismic event greater than M2.0 ⁽²⁾ ; and Local observation or report ⁽³⁾ . | 1. Initiate rate reduction plan. 2. Vent CO ₂ from surface facilities. 3. Within 24 hours of the incident, notify the UIC Program Director, ISGS, and ADM Communications of the operating status of the well. 4. Limit access to wellhead to authorized personnel only. 5. Communicate with ADM personnel and local authorities to initiate evacuation plans, as necessary. 6. Monitor well pressure, temperature, and annulus pressure to verify well status and determine the cause and extent of any failure; identify |



| Monitoring, Reporting, and Verification Plan CCS#2 | | | |
|--|----------------|---------|----------|
| Date Issued | Document # | Version | Page |
| 3/21/2024 | 180.60.ENV.309 | 10.0 | 24 of 37 |

| | | |
|-----|---|---|
| | | <p>and implement appropriate remedial actions (in consultation with the UIC Program Director).</p> <p>7. Determine if leaks to ground water or surface water occurred.</p> <p>8. If USDW contamination is detected,</p> <p>a. Notify the UIC Program Director within 24 hours of the determination.</p> <p>b. Initiate shutdown plan.</p> <p>c. Shut in well (close flow valve).</p> <p>d. Vent CO₂ from surface facilities.</p> <p>e. Identify and implement appropriate remedial actions (in consultation with the UIC Program Director).</p> <p>9. Review seismic and operational data.</p> <p>10. Report findings to the UIC Program Director and issue corrective actions ⁽⁵⁾.</p> |
| Red | <p>Seismic event greater than M2.0 ⁽²⁾; Local observation or report ⁽³⁾; and Local report and confirmation of damage ⁽⁴⁾.</p> <p>Or</p> <p>Seismic event >M3.5 ⁽²⁾</p> | <p>1. Initiate shutdown plan.</p> <p>2. Shut in well (close flow valve). Vent CO₂ from surface facilities.</p> <p>3. Within 24 hours of the incident, notify the UIC Program Director, ISGS, and ADM Communications of the operating status of the well.</p> <p>4. Limit access to wellhead to authorized personnel only.</p> <p>5. Communicate with ADM personnel and local authorities to initiate evacuation plans, as necessary.</p> <p>6. Monitor well pressure, temperature, and annulus pressure to verify well status and determine the cause and extent of any failure; identify and implement appropriate remedial actions (in consultation with the UIC Program Director).</p> <p>7. Determine if leaks to ground water or surface water occurred.</p> <p>8. If USDW contamination is detected,</p> <p>a. Notify the UIC Program Director within 24 hours of the determination.</p> <p>b. Identify and implement appropriate remedial actions (in consultation with the UIC Program Director).</p> <p>9. Review seismic and operational data.</p> <p>10. Report findings to the UIC Program Director and issue corrective actions ⁽⁵⁾.</p> |

1. Seismic events < M1.0 with an epicenter within an 8-mile radius of the injection well.
2. Determined by the local ADM or USGS seismic monitoring stations or reported by the USGS National Earthquake Information Center using the national seismic network.
3. Confirmed by local reports of felt ground motion or reported on the USGS “Did You Feel It?” reporting system.
4. Onset of damage is defined as cosmetic damage to structures – such as bricks dislodged from chimneys and parapet walls, broken windows, and fallen objects from walls, shelves, and cabinets.



| | | | |
|---|-------------------------------------|------------------------|-------------------------|
| Monitoring, Reporting, and Verification Plan CCS#2 | | | |
| Date Issued 3/21/2024 | Document # 180.60.ENV.309 | Version 10.0 | Page 25 of 37 |

5. Within 25 business days (five weeks) of change in operating state.

Based on the periodic analysis of the monitoring data, observed level of seismic activity, and local reporting of felt events, the site will be assigned an operating state. The operating state is determined using threshold criteria which correspond to the site’s potential risk and level of seismic activity. The operating state will provide operating personnel information about the potential risk of further seismic activity and associated risk of leakage and contamination of USDW’s and will guide them through a series of response actions.

Monitoring systems are anticipated to have a high capability to detect leakage that occurs. The monitoring program criteria and objectives are detailed in Section A.4 of the QASP.

9.2 Leakage Verification

Once potential leakage has been detected, the following steps will be used to verify the potential location and source of leakage. Concurrent actions to minimize the detected leak (e.g., isolating the pipeline, shutting down injection operations) will be implemented.

If leakage is detected and verified, corrective action responses will be implemented in accordance with Area of Review and Corrective Action Plan (Reference 1, Attachment B) and/or the Emergency and Remedial Response Plan (Reference 1, Attachment F).

9.2.1 Surface Leakage

9.2.1.1 Obtain photographic documentation of the leakage point. Visual signs of ice buildup or a plume are evidence of a leak.

9.2.1.2 Identify and document the leak location on a map and/or P&I diagram of the pipeline.

9.2.2 Subsurface Leakage

If leakage is detected via surface or subsurface monitoring, and the quality assurance process has confirmed anomalous data readings:



| | | | |
|---|-------------------------------------|------------------------|-------------------------|
| Monitoring, Reporting, and Verification Plan CCS#2 | | | |
| Date Issued 3/21/2024 | Document # 180.60.ENV.309 | Version 10.0 | Page 26 of 37 |

9.2.2.1 Well Pressure / Temperature Monitoring

- a. Identify and document the location (depth) of the anomalous readings.
- b. Collect and document confirmation readings and/or additional data (e.g., DTS temperature log) in accordance with the QASP to locate the source.

9.2.2.2 Mechanical Integrity Testing

- a. Identify and document the location (depth) of the anomalous readings.
- b. Collect and document confirmation readings and/or additional data (e.g., DTS temperature log) in accordance with the QASP to locate the source.

9.2.2.3 Groundwater Quality / Geochemical Monitoring

- a. Identify and document the aquifer in which the anomalous readings were measured.
- b. Collect confirmation sample(s) and/or additional data in accordance with the QASP to verify result(s).
- c. Use spatial and/or temporal analyses of available data (e.g., water quality, well measurements, reservoir flow model) to estimate the location and timing of the leakage.

9.2.2.4 Plume / Pressure Front Monitoring

- a. Determine whether injection formation characteristics (e.g., unanticipated conditions or heterogeneity) or model uncertainty are the cause of the anomalous data.
- b. If step 9.2.2.4a does not determine the cause of the anomalous data, then it will be assumed that CO₂ leakage has been verified.

9.3 Leakage Quantification

9.3.1 Surface Leakage

The leakage rate from a pinhole, crack, or other defect in the pipeline or wellhead will be estimated once leakage has been detected and confirmed, using a methodology selected by ADM. Leakage estimating methods may potentially consist of either a form of mass balance equation or models. The selected method will be based on known data such as the size of the opening and



| Monitoring, Reporting, and Verification Plan CCS#2 | | | |
|--|----------------|---------|----------|
| Date Issued | Document # | Version | Page |
| 3/21/2024 | 180.60.ENV.309 | 10.0 | 27 of 37 |

the measured pressure, density, and temperature of CO₂ in the conduit at the time the leak was discovered.

Once a leakage rate has been estimated, the quantity (mass) of leakage may be estimated by calculating the approximate length of time that leakage occurred (e.g., based on time that leak was discovered and prior time that pipeline integrity was last verified). It is understood that this quantification method may have a large margin of error; therefore, ADM will include a statistical estimate of the calculation error to document the likely range of the leakage quantity.

9.3.2 Subsurface Leakage

The ease with which leakage rate from the subsurface may be quantified will depend on the monitoring system that detected the leak. For example, leakage that is detected from pressure/temperature readings or MIT results may be more easily quantified (due to its location close to the injection source) than leakage that is detected from groundwater quality monitoring or from measurements of the CO₂ plume / pressure front.

Should leakage be detected and verified based on pressure/temperature readings or MIT results, ADM will select an estimation method to quantify leakage. Such a method could use a form of mass balance equation; as with pipeline or wellhead leakage estimates, this method may have a large margin of error; therefore, ADM will include a statistical estimate of the calculation error to document the likely range of the leakage quantity.

Similarly, should leakage be detected and verified based on groundwater monitoring data or plume / pressure front monitoring, ADM will select a method to estimate the quantity of leakage. One potential estimation method is to use the reservoir model to simulate a leak using observed data to calibrate the “leaky” model. Once calibrated, the resulting model should provide a reasonably accurate estimate of the leakage quantity.



| | | | |
|---|-------------------------------------|------------------------|-------------------------|
| Monitoring, Reporting, and Verification Plan CCS#2 | | | |
| Date Issued 3/21/2024 | Document # 180.60.ENV.309 | Version 10.0 | Page 28 of 37 |

ADM reserves the right to utilize other estimation methods (e.g., groundwater data evaluation) to evaluate leakage quantities.

9.3.3 Leakage Emitted to Surface

Mass balance calculations (see Section 11) require the estimation of leakage emitted to the surface / atmosphere. In the case of surface leakage (from pipeline or wellhead), the entire quantity of CO₂ that has leaked will be released to the atmosphere. For subsurface leakage, ADM will initially assume that the entire estimated quantity of CO₂ that has leaked will eventually reach the surface, unless modeling or other analysis is used to demonstrate that some portion of the leak will remain within the subsurface strata and will not reach the surface.

10.0 DETERMINATION OF EXPECTED BASELINES

Baseline data will consist of the following: groundwater quality and geochemistry, MIT data, injection well pulse neutron & temperature logs, injection well DTS profile, seismic and pressure front data.

10.1 Injection Well Monitoring

The following data will be collected over an established timeframe determined by ADM prior to injection operations:

1. Injection well pulse neutron and temperature logs (surface to confining zone).
2. Injection well DTS temperature profile (surface to confining zone) during well shut-in.

The average of these values will be used as the baseline for these parameters. Baseline logs for CCS#2 were collected on September 30, 2015. The baseline injection well DTS temperature profile during well shut-in was completed on December 31, 2016.

Anticipated annulus pressure as noted in Reference 1, Attachment A & C is discussed as follows:

1. The surface annulus pressure will be kept at a minimum of 100 pounds per square inch (psi) during injection.



| | | | |
|---|-------------------------------------|------------------------|-------------------------|
| Monitoring, Reporting, and Verification Plan CCS#2 | | | |
| Date Issued 3/21/2024 | Document # 180.60.ENV.309 | Version 10.0 | Page 29 of 37 |

2. At all times except during well workovers, the surface annulus pressure will be kept at a minimum pressure to maintain a pressure differential of at least 100 psi between the annular fluid directly above (higher pressure) and below (lower pressure) the injection tubing packer set at 6,320 feet below the Kelly Bushing (KB).

[Note: Surface annulus pressure downhole annulus/tubing differential pressure and injection pressure measurements are not considered baseline parameters. Injection pressure (at surface and at depth) measurements will be collected continuously once CO₂ injection starts. Injection pressure will be a function of the mass flow rate, density, and pressure of the delivered CO₂; thus, the baseline injection pressure range will be based on the anticipated range of the mass flow rate, density, and pressure of the delivered CO₂. Injection pressure will be used for comparison against other baseline data and model predictions. Maximum injection pressure at the surface is limited to 2,284 psig.

10.2 Groundwater Quality and Geochemical Change Monitoring

Groundwater quality and geochemistry will consist of the following data collection:

Shallow groundwater monitoring (4 sites):

- Cations: Al, As, Ba, Ca, Cd, Cr, Cu, Fe, K, Mg, Mn, Na, Pb, Sb, Se, Si, Tl.
- Anions: Br, Cl, F, NO₃, SO₄.
- Dissolved CO₂.
- TDS.
- Alkalinity.
- Field pH, specific conductance, temperature, and water density.

Lowermost USDW (St. Peter Sandstone):

- Cations: Al, As, Ba, Ca, Cd, Cr, Cu, Fe, K, Mg, Mn, Na, Pb, Sb, Se, Si, Tl.
- Anions: Br, Cl, F, NO₃, SO₄.
- Dissolved CO₂.
- TDS.
- Alkalinity.
- Field pH, specific conductance, temperature, and water density.
- δ¹³C of dissolved inorganic carbon (DIC).



| Monitoring, Reporting, and Verification Plan CCS#2 | | | |
|--|------------------------------|-----------------|------------------|
| Date Issued 3/21/2024 | Document # 180.60.ENV.309 | Version 10.0 | Page 30 of 37 |

Lowermost aquifer above confining zone (Ironton-Galesville Sandstone):

- Cations: Al, As, Ba, Ca, Cd, Cr, Cu, Fe, K, Mg, Mn, Na, Pb, Sb, Se, Si, Tl.
- Anions: Br, Cl, F, NO₃, SO₄.
- Dissolved CO₂.
- TDS.
- Alkalinity.
- Field pH, specific conductance, temperature, and water density.
- δ¹³C of dissolved inorganic carbon (DIC).

Further details on testing and monitoring may be found in Reference 1, Attachment C.

Baseline groundwater quality and geochemistry will be developed in accordance with approved USEPA statistical methods using software (e.g., USEPA's ProUCL) to calculate the accepted range of data values (e.g., data within the 95% confidence limit). Data values collected during injection and post-injection periods that are outside of the accepted range will be an indicator that leakage may have occurred, subject to data verification per the QASP. Baseline groundwater quality and geochemistry data collection was completed on 08/09/2015.

10.3 Mechanical Integrity Testing

Baseline MIT data was collected following installation of CCS#2 and VW#2 on 04/05/2017 and consisted of logged data from the well (e.g., cement evaluation, pressure data, or other logging type as described in Section 5.1). Baseline MIT data will be compared to subsequent MIT data (collection frequency as noted in Reference 1, Attachment C) to evaluate whether well integrity has been compromised. Baseline MIT data were collected from CCS#2 on (05/31/2015, 06/10/2015, 07/06/2015, 07/25/2015, 09/29/2015, & 09/30/2015), and from VW#2 on (11/01/2012 & 09/10/2015) and consisted of running a cement evaluation log and temperature log on CCS#2, pressure testing the casing & annulus on CCS#2, running a cement evaluation log on VW#2, and pressure testing the annulus on VW#2.

10.4 Plume and Pressure Front Monitoring

Baseline pulsed neutron logging measurements will be collected in VW#1, VW#2, CCS#1, and CCS#2. Logged data will indicate, at minimum, CO₂ saturation within the Mt. Simon. Baseline data will be compared to data collected during Years 2



| Monitoring, Reporting, and Verification Plan CCS#2 | | | |
|--|------------------------------|-----------------|------------------|
| Date Issued 3/21/2024 | Document # 180.60.ENV.309 | Version 10.0 | Page 31 of 37 |

and 4 of injection operations. Baseline RST values for CCS#1 - 12/10/2014, CCS#2 - 09/30/2015, VW#1 - 12/11/2014, and VW#2 – 11/30/2016) were collected.

Baseline 3D VSP and surface seismic surveys have been completed (performed in 2011 and 2015). Repeat seismic data were collected in 2021 and showed reasonably good correlation in terms of calculated injection volumes (3% difference) and were also found to be consistent with available pulse neutron verification data. Seismic data collected in 2030 (post-injection) will be compared to baseline surveys to evaluate plume location and configuration relative to the reservoir model prediction.

Data from seismic event monitors in the vicinity of the IL-ICCS project will be used to compare seismicity during and following injection operations with pre-injection seismicity. Increased seismicity, while not directly correlating to a leak, may provide additional information in the event of a leak detected from other monitoring data.

11.0 SITE SPECIFIC CONSIDERATIONS FOR THE MASS BALANCE EQUATIONS

40 CFR 98, Subpart RR requires greenhouse gas (GHG) reporting for geologic sequestration (GS) of carbon dioxide. 40 CFR 98.442 through 98.447 details the data calculations, monitoring, estimating, reporting and recordkeeping requirements for GS projects. This section describes how ADM will calculate the mass of CO₂ received, injected, emitted, and sequestered.

The mass (in metric tons, MT) of CO₂ sequestered in the Mt. Simon will consist of the following components (equations referenced from Subpart RR of 40 CFR 98):

- Annual mass of CO₂ received (Equations RR-1 & RR-3)

This parameter will include any CO₂ received via pipeline from offsite locations measured on a mass basis. CO₂ mass received via multiple pipelines will be summed to calculate the total CO₂ received.

- Annual mass of CO₂ injected (CO₂I, Equation RR-4 & RR-6).

Parameter CO₂I will be measured using flow meter FE006 (Coriolis meter) as referenced in P&ID No. 1041-PD-13 (Figure 3-1). Flow rate is measured on a mass



| Monitoring, Reporting, and Verification Plan CCS#2 | | | |
|--|-------------------------------------|------------------------|-------------------------|
| Date Issued 3/21/2024 | Document # 180.60.ENV.309 | Version 10.0 | Page 32 of 37 |

basis (kg/hr). Annual mass will be calculated based on the quarterly mass flow rate measurements multiplied by the quarterly CO₂ concentrations provided to USEPA by ADM for CCS#2.

- Annual mass of CO₂ emitted by surface leakage (CO₂E, Equation RR-10).
- Annual mass of CO₂ emitted from equipment leaks and vented emissions (CO₂FI).

Equipment that may emit CO₂ to the atmosphere include three thermal pressure relief valves along the pipeline (TRV-001, TRV-002, and TRV-003), and two pressure relief valves (PSV101 and MOV101) located on the annulus head tank. Process & instrumentation diagrams (P&ID) 1041-PD-13 (Figure 3-1) and 1041-PD-50 (Figure 3-2) illustrate the location of these valves.

- Annual mass of CO₂ sequestered = CO₂I – CO₂E – CO₂FI (Equation RR-12).
- Cumulative mass of CO₂ sequestered since CCS#2 became subject to reporting requirements.

Parameters CO₂E and CO₂FI will be measured using the leakage quantification procedure described in Section 9.3. ADM will estimate the mass of CO₂ emitted from relief valves or leakage points based on operating conditions at the time of the release – pipeline pressure and flow rate, set point of relief valves, the size of the valve opening, or leakage point opening, and the estimated length of time that the emission occurred. It is noted that this estimation method may have a large margin of error; therefore, ADM will include a statistical estimate of the calculation error to document the likely range of the emitted quantity.

12.0 ESTIMATED SCHEDULE FOR IMPLEMENTATION

Injection operations at CCS#2 started on April 7, 2017. At this time, ADM began implementation of the leakage detection process and calculation of the total amount of CO₂ sequestered in the Mt. Simon formation.

13.0 QUALITY ASSURANCE PROGRAM



| Monitoring, Reporting, and Verification Plan CCS#2 | | | |
|--|----------------|---------|----------|
| Date Issued | Document # | Version | Page |
| 3/21/2024 | 180.60.ENV.309 | 10.0 | 33 of 37 |

Quality assurance procedures for the IL-ICCS project are provided in the Quality Assurance and Surveillance Plan (QASP) found in Reference 1, Attachment C, Appendix A.

- Section A of the QASP details project organization, project reasoning and regulatory information, project description, quality objectives and criteria, training and certification requirements, and project documentation/ recordkeeping.
- Section B details acquisition and generation of project data: sampling design, methods, handling and custody; sample analytical methods; quality control; instrument/equipment inspection, testing, calibration, operation and maintenance; use of indirect measurements, and data management.
- Section C details project assessments, corrective actions, and internal reporting.
- Section D discusses data validation and use.

14.0 RECORDS RETENTION

ADM will maintain and submit records required under Section N of the Final Permit issued by USEPA. Reports will be maintained in electronic format at the ADM Decatur facility unless the USEPA Director is otherwise notified by ADM.



| Monitoring, Reporting, and Verification Plan CCS#2 | | | |
|--|----------------|---------|----------|
| Date Issued | Document # | Version | Page |
| 3/21/2024 | 180.60.ENV.309 | 10.0 | 34 of 37 |

REFERENCE 1

USEPA Underground Injection Control Permit, Class VI, for ADM CCS#2, Permit No. IL-115-6A-0001, proposed modification published November 22, 2016 (as revised from time to time), permit modification effective on December 18, 2017, and permit modification effective December 20, 2021, including Attachments A, B, C (with Quality Assurance & Surveillance Plan), D, E, F, G, H, and I.

U.S. ENVIRONMENTAL PROTECTION AGENCY
UNDERGROUND INJECTION CONTROL PERMIT
CLASS VI

TABLE OF CONTENTS

| | |
|---|---|
| AUTHORITY | 1 |
| PERMIT CONDITIONS | 2 |
| A. EFFECT OF PERMIT | 2 |
| B. PERMIT ACTIONS..... | 2 |
| 1. Modification, Revocation and Reissuance, and Termination | 2 |
| 2. Minor Modifications | 2 |
| 3. Transfer of Permits | 2 |
| C. SEVERABILITY | 2 |
| D. CONFIDENTIALITY..... | 3 |
| E. DEFINITION..... | 3 |
| F. DUTIES AND REQUIREMENTS..... | 3 |
| 1. Duty to Comply..... | 3 |
| 2. Duty to Reapply | 3 |
| 3. Penalties for Violations of Permit Conditions | 3 |
| 4. Need to Halt or Reduce Activity Not a Defense..... | 3 |
| 5. Duty to Mitigate..... | 3 |
| 6. Proper Operation and Maintenance | 4 |
| 7. Duty to Provide Information..... | 4 |
| 8. Inspection and Entry | 4 |
| 9. Signatory Requirements..... | 4 |
| G. AREA OF REVIEW AND CORRECTIVE ACTION | 4 |
| H. FINANCIAL RESPONSIBILITY | 5 |
| 1. Financial Responsibility..... | 5 |
| 2. Cost Estimate Updates | 5 |
| 3. Notification | 5 |
| 4. Establishing Other Coverage | 6 |
| I. CONSTRUCTION..... | 6 |
| 1. Siting..... | 6 |
| 2. Casing and Cementing | 6 |
| 3. Tubing and Packer Specifications..... | 6 |
| J. PRE-INJECTION TESTING..... | 7 |
| K. OPERATIONS..... | 8 |
| 1. Injection Pressure Limitation | 8 |
| 2. Stimulation Program | 8 |
| 3. Additional Injection Limitation | 8 |

| | |
|--|----|
| 4. Annulus Fluid..... | 8 |
| 5. Annulus/Tubing Pressure Differential | 8 |
| 6. Automatic Alarms and Automatic Shut-off System | 8 |
| 7. Precautions to Prevent Well Blowouts | 9 |
| 8. Circumstances Under Which Injection Must Cease | 9 |
| 9. Approaches for Ceasing Injection..... | 9 |
| L. MECHANICAL INTEGRITY..... | 9 |
| 1. Standards..... | 9 |
| 2. Mechanical Integrity Testing..... | 10 |
| 3. Prior Notice and Reporting | 11 |
| 4. Gauge and Meter Calibration..... | 11 |
| 5. Loss of Mechanical Integrity | 11 |
| 6. Mechanical Integrity Testing on Request From Director | 12 |
| M. TESTING AND MONITORING | 12 |
| 1. Testing and Monitoring Plan | 12 |
| 2. Carbon Dioxide Stream Analysis..... | 13 |
| 3. Continuous Monitoring..... | 13 |
| 4. Corrosion Monitoring | 13 |
| 5. Ground Water Quality Monitoring | 13 |
| 6. External Mechanical Integrity Testing..... | 14 |
| 7. Pressure Fall-Off Test..... | 14 |
| 8. Plume and Pressure Front Tracking..... | 14 |
| 9. Surface Air and/or Soil Gas Monitoring..... | 14 |
| 10. Additional Monitoring | 14 |
| N. REPORTING AND RECORDKEEPING | 14 |
| 1. Electronic Reporting | 14 |
| 2. Semi-Annual Reports..... | 14 |
| 3. 24-Hour Reporting | 15 |
| 4. Reports on Well Tests and Workovers | 16 |
| 5. Advance Notice Reporting..... | 16 |
| 6. Additional Reports | 17 |
| 7. Records | 17 |
| O. WELL PLUGGING, POST-INJECTION SITE CARE, AND SITE CLOSURE | 18 |
| 1. Well Plugging Plan | 18 |
| 2. Revision of Well Plugging Plan..... | 18 |
| 3. Notice of Plugging and Abandonment..... | 18 |
| 4. Plugging and Abandonment Approval and Report..... | 18 |
| 5. Temporary Abandonment | 19 |
| 6. Post-Injection Site Care and Site Closure Plan..... | 19 |
| P. EMERGENCY AND REMEDIAL RESPONSE | 21 |
| Q. COMMENCING INJECTION | 21 |

ATTACHMENTS23

- A. SUMMARY OF REQUIREMENTS
- B. AREA OF REVIEW AND CORRECTIVE ACTION PLAN
- C. TESTING AND MONITORING PLAN
- D. INJECTION WELL PLUGGING PLAN
- E. POST-INJECTION SITE CARE AND SITE CLOSURE PLAN
- F. EMERGENCY AND REMEDIAL RESPONSE PLAN
- G. CONSTRUCTION DETAILS
- H. FINANCIAL ASSURANCE DEMONSTRATION
- I. STIMULATION PROGRAM

This page is intentionally blank



UNITED STATES ENVIRONMENTAL PROTECTION AGENCY
REGION 5
77 W. JACKSON BOULEVARD
CHICAGO, IL 60604-3590

Page 1 of 23

**UNITED STATES ENVIRONMENTAL PROTECTION AGENCY
UNDERGROUND INJECTION CONTROL PERMIT: CLASS VI**

Permit Number: IL-115-6A-0001

Facility Name: CCS#2

Pursuant to the Safe Drinking Water Act and Underground Injection Control regulations of the U.S. Environmental Protection Agency codified at Title 40 of the Code of Federal Regulations (40 CFR) Parts 124, 144, 146, and 147,

Archer Daniels Midland of Decatur, IL

hereinafter, the permittee, is hereby authorized to construct and operate a Class VI injection well located in the State of Illinois, Macon County, T 17N, R 3E of 3rd Principal Meridian, Section 32, 39°53'09.32835"N, -88°53'16.68306"W, for injection of the Carbon Dioxide (CO₂) stream generated by ADM's fuel ethanol production unit and as characterized in the permit application and the administrative record as a liquid, supercritical fluid, or gas into the Mount Simon at depths between 5,553 feet and 7,043 feet below ground surface upon the express condition that the permittee meet the restrictions set forth herein. The designated confining zone for this injection is the Eau Claire Formation. Injection shall not commence until the operator has received written authorization from the Director of the Water Division of EPA Region 5, in accordance with Section Q of this permit.

All references to Title 40 of the Code of Federal Regulations are to all regulations that are in effect on the date that this permit is effective. The following attachments are incorporated into this permit as enforceable conditions: A, B, C, D, E, F, G, H and I.

This is a modification of a permit that was signed on September 23, 2014. The modification shall become effective on 12-20-2021. The permit shall remain in full force and effect during the operating life of the facility and the post-injection site care period until site closure is authorized and completed, unless this permit is revoked and reissued, terminated, or modified pursuant to 40 CFR 144.39, 144.40, or 144.41. This permit shall also remain in effect upon delegation of primary enforcement responsibility to the State of Illinois until such time as the State issues its own permit to the permittee or the State chooses to adopt this permit as a State permit. This permit will be reviewed at least every five years from the effective date specified above.

Signed and Dated: 11-05-2021

Tera L. Fong
Director, Water Division

PERMIT CONDITIONS

A. EFFECT OF PERMIT

The permittee is allowed to engage in underground injection in accordance with the conditions of this permit. Notwithstanding any other provisions of this permit, the permittee authorized by this permit shall not construct, operate, maintain, convert, plug, abandon, or conduct any other injection activity in a manner that allows the movement of injection, annulus or formation fluids into underground sources of drinking water (USDWs) or any unauthorized zones. The objective of this permit is to prevent the movement of fluids into or between USDWs or into any unauthorized zones consistent with the requirements at 40 CFR 146.86(a). Any underground injection activity not specifically authorized in this permit is prohibited. For purposes of enforcement, compliance with this permit during its term constitutes compliance with Part C of the Safe Drinking Water Act (SDWA). Such compliance does not constitute a defense to any action brought under Section 1431 of the SDWA or any other common or statutory law other than Part C of the SDWA. Issuance of this permit does not convey property rights of any sort or any exclusive privilege; nor does it authorize any injury to persons or property, any invasion of other private rights, or any infringement of State or local laws or regulations. Nothing in this permit shall be construed to relieve the permittee of any duties under applicable regulations.

B. PERMIT ACTIONS

1. **Modification, Revocation and Reissuance, and Termination** – The Director of the Water Division of Region 5 of the U. S. Environmental Protection Agency (EPA), hereinafter, the Director, may, for cause or upon request from any interested person, including the permittee, modify, revoke and reissue, or terminate this permit in accordance with 40 CFR 124.5, 144.12, 146.86(a), 144.39, and 144.40. The permit is also subject to minor modifications for cause as specified in 40 CFR 144.41. The filing of a request for a permit modification, revocation and reissuance, or termination, or the notification of planned changes, or anticipated noncompliance on the part of the permittee does not stay the applicability or enforceability of any permit condition.
2. **Minor Modifications** – Upon the consent of the permittee, the Director may modify a permit to make the corrections or allowances for minor changes in the permitted activity as listed in 40 CFR 144.41. Any permit modification not processed as a minor modification under 40 CFR 144.41 must be made for cause, and with part 124 draft permit and public notice as required in 40 CFR 144.39.
3. **Transfer of Permits** – This permit is not transferable to any person except in accordance with 40 CFR 144.38(a) and Section N(6)(b) of this permit.

C. SEVERABILITY

The provisions of this permit are severable, and if any provision of this permit or the application of any provision of this permit to any circumstance is held invalid, the application of such provision to other circumstances and the remainder of this permit shall not be affected thereby.

D. CONFIDENTIALITY

In accordance with 40 CFR Part 2 (Public Information) and 40 CFR 144.5, any information submitted to EPA pursuant to this permit may be claimed as confidential business information by the submitter. Any such claim must be asserted at the time of submission by clearly identifying each page with the words "confidential business information" on every page containing such information. If no claim is made at the time of submission, EPA may make the information available to the public without further notice. If a claim is asserted, the validity of the claim will be assessed in accordance with the procedures in 40 CFR Part 2. Claims of confidentiality for the following information will be denied:

1. The name and address of the permittee; and
2. Information which deals with the existence, absence or level of contaminants in drinking water.

E. DEFINITION

All terms used in this permit shall have the meaning set forth in the SDWA and Underground Injection Control regulations specified at 40 CFR parts 124, 144, 146, and 147. Unless specifically stated otherwise, all references to "days" in this permit should be interpreted as calendar days.

F. DUTIES AND REQUIREMENTS

1. **Duty to Comply** – The permittee shall comply with all conditions of this permit. Any permit noncompliance constitutes a violation of the SDWA and is grounds for enforcement action, permit termination, revocation and reissuance, modification, or for denial of a permit renewal application.
2. **Duty to Reapply** – If the permittee wishes to continue an activity regulated by this permit after the expiration or termination of this permit, the permittee must apply for and obtain a new permit.
3. **Penalties for Violations of Permit Conditions** – Any person who violates a permit requirement is subject to civil penalties and other enforcement action under the SDWA. Any person who willfully violates permit conditions may be subject to criminal prosecution under the SDWA and other applicable statutes and regulations.
4. **Need to Halt or Reduce Activity Not a Defense** – It shall not be a defense for the permittee in an enforcement action to claim that it would have been necessary to halt or reduce the permitted activity in order to maintain compliance with the conditions of this permit.
5. **Duty to Mitigate** – The permittee shall take all timely and reasonable steps necessary to minimize or correct any adverse impact on the environment resulting from noncompliance with this permit.

6. **Proper Operation and Maintenance** – The permittee shall at all times properly operate and maintain all facilities and systems of treatment and control and related appurtenances which are installed or used by the permittee to achieve compliance with the conditions of this permit. Proper operation and maintenance includes, among other things, effective performance, adequate funding, adequate operator staffing and training, and adequate laboratory and process controls, including appropriate quality assurance procedures. This provision requires the operation of back-up or auxiliary facilities or similar systems only when necessary to achieve compliance with the conditions of this permit.
7. **Duty to Provide Information** – The permittee shall furnish to the Director in an electronic format, within a time specified, any information which the Director may request to determine whether cause exists for modifying, revoking and reissuing, or terminating this permit, or to determine compliance with this permit or the UIC regulations. The permittee shall also furnish to the Director, upon request within a time specified, electronic copies of records required to be kept by this permit.
8. **Inspection and Entry** – The permittee shall allow the Director or an authorized representative, upon the presentation of credentials and other documents as may be required by law, to:
 - (a) Enter upon the permittee's premises where a regulated facility or activity is located or conducted, or where electronic or non-electronic records are kept under the conditions of this permit;
 - (b) Have access to and copy, at reasonable times, any electronic or non-electronic records that are kept under the conditions of this permit;
 - (c) Inspect, at reasonable times, any facilities, equipment (including monitoring and control equipment), practices, or operations regulated or required under this permit; and
 - (d) Sample or monitor, at reasonable times, for the purposes of assuring permit compliance or as otherwise authorized by the SDWA, any substances or parameters at any location, including facilities, equipment or operations regulated or required under this permit.
9. **Signatory Requirements** – All reports or other information, required to be submitted by this permit or requested by the Director shall be signed and certified in accordance with 40 CFR 144.32.

G. AREA OF REVIEW AND CORRECTIVE ACTION

1. The Area of Review (AoR) is the region surrounding the geologic sequestration project where USDWs may be endangered by the injection activity. The area of review is delineated using computational modeling that accounts for the physical and chemical properties of all phases of the injected carbon dioxide stream and is based on available site characterization, monitoring, and operational data. The permittee shall maintain and comply with the approved Area of Review and Corrective Action Plan (Attachment B of this permit) which is an enforceable condition of this permit and shall meet the requirements of 40 CFR 146.84.

2. At the fixed frequency specified in the Area of Review and Corrective Action Plan, or more frequently when monitoring and operational conditions warrant, the permittee must reevaluate the area of review and perform corrective action in the manner specified in 40 CFR 146.84 and update the Area of Review and Corrective Action Plan or demonstrate to the Director that no update is needed.
3. Following each AoR reevaluation or a demonstration that no evaluation is needed, the permittee shall submit the resultant information in an electronic format to the Director for review and approval of the AoR results. Once approved by the Director, the revised Area of Review and Corrective Action Plan will become an enforceable condition of this permit.

H. FINANCIAL RESPONSIBILITY

1. **Financial Responsibility** – The permittee shall maintain financial responsibility and resources to meet the requirements of 40 CFR 146.85 and the conditions of this permit. Financial responsibility shall be maintained through all phases of the project. The approved financial assurance mechanism is found in Attachment H and in the administrative record of this permit.

The financial instrument(s) must be sufficient to cover the cost of:

- (a) Corrective action (that meets the requirements of 40 CFR 146.84);
 - (b) Injection well plugging (that meets the requirements of 40 CFR 146.92);
 - (c) Post injection site care and site closure (that meets the requirements of 40 CFR 146.93);
 - (d) Emergency and remedial response (that meets the requirements of 40 CFR 146.94).
2. **Cost Estimate Updates** – During the active life of the geologic sequestration project, the permittee must adjust the cost estimate for inflation within 60 days prior to the anniversary date of the establishment of the financial instrument(s) and provide this adjustment to the Director in an electronic format. The permittee must also provide to the Director written updates in an electronic format of adjustments to the cost estimate within 60 days of any amendments to the Project Plans included as Attachments B – F of this permit, which address items (a) through (d) in Section H(1) of this permit.
 3. **Notification** –
 - (a) Whenever the current cost estimate increases to an amount greater than the face amount of a financial instrument currently in use, the permittee, within 60 days after the increase, must either cause the face amount to be increased to an amount at least equal to the current cost estimate and submit evidence of such increase to the Director, or obtain other financial responsibility instruments to cover the increase. Whenever the current cost estimate decreases, the face amount of the financial assurance instrument may be reduced to the amount of the current cost estimate only after the permittee has received written approval from the Director.

- (b) The permittee must notify the Director by certified mail and in an electronic format of adverse financial conditions such as bankruptcy that may affect the ability to carry out injection well plugging, post-injection site care and site closure, and any applicable ongoing actions under Corrective Action and/or Emergency and Remedial Response.
- (i) In the event that the permittee or the third party provider of a financial responsibility instrument is going through a bankruptcy, the permittee must notify the Director by certified mail and in an electronic format of the commencement of a voluntary or involuntary proceeding under Title 11 (Bankruptcy), U.S. Code, naming the permittee as debtor, within 10 days after commencement of the proceeding.
 - (ii) A guarantor of a corporate guarantee must make such a notification if he or she is named as debtor, as required under the terms of the guarantee.
 - (iii) A permittee who fulfills the requirements of paragraph (a) of this section by obtaining a trust fund, surety bond, letter of credit, escrow account, or insurance policy will be deemed to be without the required financial assurance in the event of bankruptcy of the trustee or issuing institution, or a suspension or revocation of the authority of the trustee institution to act as trustee of the institution issuing the trust fund, surety bond, letter of credit, escrow account, or insurance policy.
4. **Establishing Other Coverage** – The permittee must establish other financial assurance or liability coverage acceptable to the Director, within 60 days of the occurrence of the events in Section H(2) or H(3) of this permit.

I. CONSTRUCTION

1. **Siting** – The permittee has demonstrated to the satisfaction of the Director that the well is in an area with suitable geology in accordance with the requirements at 40 CFR 146.83.
2. **Casing and Cementing** – Casing and cement or other materials used in the construction of the well must have sufficient structural strength for the life of the geologic sequestration project. All well materials must be compatible with all fluids with which the materials may be expected to come into contact and must meet or exceed standards developed for such materials by the American Petroleum Institute, ASTM International, or comparable standards acceptable to the Director. The casing and cementing program must prevent the movement of fluids into or between USDWs for the expected life of the well in accordance with 40 CFR 146.86. The casing and cement used in the construction of this well are shown in Attachment G of this permit and in the administrative record for this permit. Any change must be submitted in an electronic format for approval by the Director before installation.
3. **Tubing and Packer Specifications** – Tubing and packer materials used in the construction of the well must be compatible with fluids with which the materials may be expected to come into contact and must meet or exceed standards developed for such materials by the American Petroleum Institute, ASTM International, or comparable standards acceptable to the Director. The permittee shall inject only through tubing with a packer set within the long string casing at a point within or below the confining zone immediately above the injection

zone. The tubing and packer used in the well are represented in engineering drawings contained in Attachment G of this permit. Any change must be submitted in an electronic format for approval by the Director before installation.

J. PRE-INJECTION TESTING

1. Prior to the Director authorizing injection, the permittee shall perform all pre-injection logging, sampling, and testing specified at 40 CFR 146.87. This testing shall include:
 - (a) Logs, surveys and tests to determine or verify the depth, thickness, porosity, permeability, lithology, and formation fluid salinity in all relevant geologic formations. These tests shall include:
 - (i) Deviation checks that meet the requirements of 40 CFR 146.87(a)(1);
 - (ii) Logs and tests before and upon installation of the surface casing that meet the requirements of 40 CFR 146.87(a)(2);
 - (iii) Logs and tests before and upon installation of the long-string casing that meet the requirements of 40 CFR 146.87(a)(3);
 - (iv) Tests to demonstrate internal and external mechanical integrity that meet the requirements of 40 CFR 146.87(a)(4); and
 - (v) Any alternative methods that are required by and/or approved by the Director pursuant to 40 CFR 146.87(a)(5).
 - (b) Whole cores or sidewall cores of the injection zone and confining system and formation fluid samples from the injection zone that meet the requirements of 40 CFR 146.87(b);
 - (c) Records of the fluid temperature, pH, conductivity, reservoir pressure, and static fluid level of the injection zone that meet the requirements of 40 CFR 146.87(c);
 - (d) Tests to provide information about the injection and confining zones, including calculated fracture pressure and the physical and chemical characteristics of the injection and confining zones and the formation fluids in the injection zone that meet the requirements of 40 CFR 146.87(d); and
 - (e) Tests to verify hydrogeologic characteristics of the injection zone that meet the requirements of 40 CFR 146.87(e), including:
 - (i) A pressure fall-off test and
 - (ii) A pumping test or injectivity tests.
2. The permittee shall submit to the Director for approval in an electronic format a schedule for logging and testing activities 30 days prior to conducting the first test and submit any changes to the schedule 30 days prior to the next scheduled test. The permittee must provide

the Director or their representative with the opportunity to witness all logging, sampling, and testing required under this Section.

K. OPERATIONS

1. **Injection Pressure Limitation** – Except during stimulation, the permittee must ensure that injection pressure does not exceed 90 percent of the fracture pressure of the injection zone(s) so as to ensure that the injection does not initiate new fractures or propagate existing fractures in the injection zone(s). In no case shall injection pressure initiate fractures or propagate existing fractures in the confining zone or cause the movement of injection or formation fluids into a USDW. The maximum injection pressure limit is listed in Attachment A.
2. **Stimulation Program** – All stimulation activities must be approved by EPA prior to conducting the stimulation. The permittee must carry out the Stimulation Program in accordance with Attachment I of this permit.
3. **Additional Injection Limitation** – No injectate other than that identified on page 1 of this permit shall be injected except fluids used for stimulation, rework, and well tests as approved by the Director.
4. **Annulus Fluid** – The permittee must fill the annulus between the tubing and the long string casing with a non-corrosive fluid approved by the Director.
5. **Annulus/Tubing Pressure Differential** – Except during workovers or times of annulus maintenance, the permittee must maintain on the annulus a pressure that exceeds the operating injection pressure as specified in Attachment A of this permit, unless the Director determines that such requirement might harm the integrity of the well or endanger USDWs.
6. **Automatic Alarms and Automatic Shut-off System** –
 - (a) The permittee must:
 - (i) Install, continuously operate, and maintain an automatic alarm and an automatic shut-off system or, at the discretion of the Director, down-hole shut-off systems, or other mechanical devices that provide equivalent protection; and
 - (ii) Successfully demonstrate the functionality of the alarm system and shut-off system prior to the Director authorizing injection, and at a minimum of once every twelfth month after the last approved demonstration.
 - (b) Testing under this Section must involve subjecting the system to simulated failure conditions and must be witnessed by the Director or his or her representative unless the Director authorizes an unwitnessed test in advance. The permittee must provide notice in an electronic format 30 days prior to running the test and must provide the Director or their representative the opportunity to attend. The test must be documented using either a mechanical or digital device which records the value of

the parameter of interest, or by a service company job record. A final report including any additional interpretation necessary for evaluation of the testing must be submitted in an electronic format within the time period specified in Section N(4) of this permit.

7. **Precautions to Prevent Well Blowouts** – Except at specific times as approved by the Director, the permittee shall maintain on the well a pressure which will prevent the return of the injection fluid to the surface. The well bore must be filled with a high specific gravity fluid during workovers to maintain a positive (downward) gradient and/or a plug shall be installed which can resist the pressure differential. A blowout preventer must be installed and kept in proper operational condition whenever the wellhead is removed to work on the well. The permittee shall follow procedures such as those below to assure that a backflow or blowout does not occur:

- (a) Limit the temperature and/or corrosivity of the injectate; and
- (b) Develop procedures necessary to assure that pressure imbalances do not occur.

8. **Circumstances Under Which Injection Must Cease** –

Injection shall cease when any of the following circumstances arises:

- (a) Failure of the well to pass a mechanical integrity test;
- (b) A loss of mechanical integrity during operation;
- (c) The automatic alarm or automatic shut-off system is triggered;
- (d) A significant unexpected change in the annulus or injection pressure;
- (e) The Director determines that the well lacks mechanical integrity; or
- (f) The permittee is unable to maintain compliance with any permit condition or regulatory requirement and the Director determines that injection should cease.

9. **Approaches for Ceasing Injection** –

- (a) The permittee must cease injection and shut-in the well as outlined under Routine Shutdown Procedure in Attachment A of this permit; or
- (b) The permittee must immediately cease injection and shut-in the well as outlined in the Emergency and Remedial Response Plan (Attachment F of this permit).

L. MECHANICAL INTEGRITY

1. **Standards** – Other than during periods of well workover (maintenance) approved by the Director in which the sealed tubing-casing annulus is disassembled for maintenance or corrective procedures, the injection well must have and maintain mechanical integrity

consistent with 40 CFR 146.89. To meet these requirements, mechanical integrity tests/demonstrations must be witnessed by the Director or an authorized representative of the Director unless prior approval has been granted by the Director to run an un-witnessed test. In order to conduct testing without an EPA representative, the following procedures must be followed.

- (a) The permittee must submit prior notification in an electronic format within the time period specified in Section L(3) of this permit, including the information that no EPA representative is available, and receive permission from the Director to proceed;
- (b) The test must be performed in accordance with the Testing and Monitoring Plan (Attachment C of this permit) and documented using either a mechanical or digital device that records the value of the parameter of interest;
- (c) A final report including any additional interpretation necessary for evaluation of the testing must be submitted in an electronic format within the time period specified in Section N(4) of this permit.

2. **Mechanical Integrity Testing** – The permittee shall conduct a casing inspection log and mechanical integrity testing as follows:

- (a) Prior to receiving authorization to inject, the permittee shall perform the following testing to demonstrate internal mechanical integrity pursuant to 40 CFR 146.87(a)(4):
 - (i) A pressure test with liquid or gas; and
 - (ii) A casing inspection log; or
 - (iii) An alternative approved by the Director that has been approved by the Administrator pursuant to requirements at 40 CFR 146.89(e).
- (b) Prior to receiving authorization to inject, the permittee shall perform the following testing to demonstrate external mechanical integrity pursuant to 40 CFR 146.87(a)(4):
 - (i) A tracer survey such as an oxygen activation log; or
 - (ii) A temperature or noise log; or
 - (iii) An alternative approved by the Director that has been approved by the Administrator pursuant to requirements at 40 CFR 146.89(e).
- (c) Other than during periods of well workover (maintenance) approved by the Director in which the sealed tubing-casing annulus is disassembled for maintenance or corrective procedures, the permittee must continuously monitor injection pressure, injection rate, injection volumes; pressure on the annulus between tubing and long string casing; and annulus fluid volume as specified in 40 CFR 146.88(e), and 146.89(b).

- (d) At least once per year, the permittee must perform the following testing to demonstrate external mechanical integrity pursuant to 40 CFR 146.89(c):
 - (i) An Administrator-approved tracer survey such as an oxygen-activation log; or
 - (ii) A temperature or noise log. The Director may require such tests whenever the well is worked over; or
 - (iii) An alternative approved by the Director that has been approved by the Administrator pursuant to requirements at 40 CFR 146.89(e).
- (e) After any workover that may compromise the internal mechanical integrity of the well, the well shall be tested by means of a pressure test approved by the Director and the well must pass the test to demonstrate mechanical integrity.
- (f) Prior to plugging the well, the permittee shall demonstrate external mechanical integrity as described in the Injection Well Plugging Plan and that meets the requirements of 40 CFR 146.92(a).
- (g) The Director may require the use of any other tests to demonstrate mechanical integrity other than those listed above with the written approval of the Administrator pursuant to requirements at 40 CFR 146.89(e).

3. **Prior Notice and Reporting** –

- (a) The permittee shall notify the Director in an electronic format of his or her intent to demonstrate mechanical integrity in an electronic format at least 30 days prior to such demonstration. At the discretion of the Director a shorter time period may be allowed.
- (b) Reports of mechanical integrity demonstrations which include logs must include an interpretation of results by a knowledgeable log analyst. The permittee shall report in an electronic format the results of a mechanical integrity demonstration within the time period specified in Section N(4) of this permit.

4. **Gauge and Meter Calibration** – The permittee shall calibrate all gauges used in mechanical integrity demonstrations and other required monitoring to an accuracy of not less than 0.5 percent of full scale, within one year prior to each required test. The date of the most recent calibration shall be noted on or near the gauge or meter. A copy of the calibration certificate shall be submitted to the Director in an electronic format with the report of the test. Pressure gauge resolution shall be no greater than five psi. Certain mechanical integrity and other testing may require greater accuracy and shall be identified in the procedure submitted to the Director prior to the test.

5. **Loss of Mechanical Integrity** –

- (a) If the permittee or the Director finds that the well fails to demonstrate mechanical integrity during a test, or fails to maintain mechanical integrity during operation, or that a loss of mechanical integrity as defined by 40 CFR 146.89(a)(1) or (2) is suspected

during operation (such as a significant unexpected change in the annulus or injection pressure), the permittee must:

- (i) Cease injection in accordance with Sections K(8) and K(9)(a) or (b), and Attachments A or F of this permit;
 - (ii) Take all steps reasonably necessary to determine whether there may have been a release of the injected carbon dioxide stream or formation fluids into any unauthorized zone. If there is evidence of USDW endangerment, implement the Emergency and Remedial Response Plan (Attachment F of this permit);
 - (iii) Follow the reporting requirements as directed in Section N of this permit;
 - (iv) Restore and demonstrate mechanical integrity to the satisfaction of the Director and receive written approval from the Director prior to resuming injection; and
 - (v) Notify the Director in an electronic format when injection can be expected to resume.
- (b) If a shutdown (*i.e.*, down-hole or at the surface) is triggered, the permittee must immediately investigate and identify as expeditiously as possible the cause of the shutdown. If, upon such investigation, the well appears to be lacking mechanical integrity, or if monitoring required indicates that the well may be lacking mechanical integrity, the permittee must take the actions listed above in Section L(5)(a)(i) through (v).
- (c) If the well loses mechanical integrity prior to the next scheduled test date, then the well must either be plugged or repaired and retested within 30 days of losing mechanical integrity. The permittee shall not resume injection until mechanical integrity is demonstrated and the Director gives written approval to recommence injection in cases where the well has lost mechanical integrity.
6. **Mechanical Integrity Testing on Request From Director** – The permittee shall demonstrate mechanical integrity at any time upon written notice from the Director.

M. TESTING AND MONITORING

1. **Testing and Monitoring Plan** –

- (a) The permittee shall maintain and comply with the approved Testing and Monitoring Plan (Attachment C of this permit) and with the requirements at 40 CFR 144.51(j), 146.88(e), and 146.90. The Testing and Monitoring Plan is an enforceable condition of this permit. Samples and measurements taken for the purpose of monitoring shall be representative of the monitored activity. Procedures for all testing and monitoring under this permit must be submitted to the Director in an electronic format for approval at least 30 days prior to the test. In performing all testing and monitoring under this permit, the permittee must follow the procedures approved by the Director. If the permittee is unable to follow the EPA approved procedures, then, the permittee must contact the Director at least 30

days prior to testing to discuss options, if any are feasible. When the test report is submitted, a full explanation must be provided as to why any approved procedures were not followed. If the approved procedures were not followed, EPA may take an appropriate action, including but not limited to, requiring the permittee to re-run the test.

- (b) The permittee must update the Testing and Monitoring Plan as required at 40 CFR 146.90 (j) to incorporate monitoring and operational data and in response to AoR reevaluations required under Section G.2. of this permit or demonstrate to the Director that no update is needed. The amended Testing and Monitoring Plan or demonstration shall be submitted to the Director in an electronic format within one year of an AoR reevaluation; following any significant changes to the facility such as addition of monitoring wells or newly permitted injection wells within the AoR; or when required by the Director.
 - (c) Following each update of the Testing and Monitoring Plan or a demonstration that no update is needed, the permittee shall submit the resultant information in an electronic format to the Director for review and approval of the results. Once approved by the Director, the revised Testing and Monitoring Plan will become an enforceable condition of this permit.
2. **Carbon Dioxide Stream Analysis** – The permittee shall analyze the carbon dioxide stream with sufficient frequency to yield data representative of its chemical and physical characteristics, as described in the Testing and Monitoring Plan and to meet the requirements of 40 CFR 146.90(a).
 3. **Continuous Monitoring** – The permittee shall maintain continuous monitoring devices and use them to monitor injection pressure, flow rate, volume, the pressure on the annulus between the tubing and the long string of casing, annulus fluid level, and temperature. This monitoring shall be performed as described in the Testing and Monitoring Plan to meet the requirements of 40 CFR 146.90(b). The permittee shall maintain for EPA's inspection at the facility an appropriately scaled, continuous record of these monitoring results as well as original files of any digitally recorded information pertaining to these operations.
 4. **Corrosion Monitoring** – The permittee shall perform corrosion monitoring of the well materials for loss of mass, thickness, cracking, pitting, and other signs of corrosion on a quarterly basis using the procedures described in the Testing and Monitoring Plan and in accordance with 40 CFR 146.90(c) to ensure that the well components meet the minimum standards for material strength and performance set forth in 40 CFR 146.86(b).
 5. **Ground Water Quality Monitoring**– The permittee shall monitor ground water quality and geochemical changes above the confining zone(s) that may be a result of carbon dioxide movement through the confining zone(s) or additional identified zones. This monitoring shall be performed for the parameters identified in the Testing and Monitoring Plan at the locations and depths, and at frequencies described in the Testing and Monitoring Plan to meet the requirements of 40 CFR 146.90(d).

6. **External Mechanical Integrity Testing** – The permittee shall demonstrate external mechanical integrity as described in the Testing and Monitoring Plan and Section L of this permit to meet the requirements of 40 CFR 146.90(e).
7. **Pressure Fall-Off Test** – The permittee shall conduct a pressure fall-off test at least once every five years unless more frequent testing is required by the Director based on site-specific information. The test shall be performed as described in the Testing and Monitoring Plan to meet the requirements of 40 CFR 146.90(f).
8. **Plume and Pressure Front Tracking** – The permittee shall track the extent of the carbon dioxide plume and the presence or absence of elevated pressure (e.g., the pressure front) as described in the Testing and Monitoring Plan.
 - (a) The permittee shall use direct methods to track the position of the carbon dioxide plume and the pressure front in the injection zone as described in the Testing and Monitoring Plan and to meet the requirements of 40 CFR 146.90(g)(1).
 - (b) The permittee shall use indirect methods to track the position of the carbon dioxide plume and pressure front as described in the Testing and Monitoring Plan and to meet the requirements of 40 CFR 146.90(g)(2).
9. **Surface Air and/or Soil Gas Monitoring** – The permittee shall conduct any surface air monitoring and/or soil gas monitoring required by the Director to detect movement of carbon dioxide that could endanger a USDW at the frequency and locations described in the Testing and Monitoring Plan to meet the requirements of 40 CFR 146.90(h).
10. **Additional Monitoring** – If required by the Director as provided in 40 CFR 146.90(i), the permittee shall perform any additional monitoring determined to be necessary to support, upgrade, and improve computational modeling of the AoR evaluation required under 40 CFR 146.84(c) and to determine compliance with standards under 40 CFR 144.12 or 40 CFR 146.86(a). This monitoring shall be performed as described in a modification to the Testing and Monitoring Plan.

N. REPORTING AND RECORDKEEPING

1. **Electronic Reporting** – Electronic reports, submittals, notifications and records made and maintained by the permittee under this permit must be in an electronic format approved by EPA. The permittee shall electronically submit all required reports to the Director at:

<https://epa.veio.pnnl.gov/operators>
2. **Semi-Annual Reports** – The permittee shall submit semi-annual reports containing:
 - (a) Any changes to the physical, chemical, and other relevant characteristics of the carbon dioxide stream from the proposed operating data;
 - (b) Monthly average, maximum, and minimum values for injection pressure, flow rate and daily volume, temperature, and annular pressure;

- (c) A description of any event that exceeds operating parameters for annulus pressure or injection pressure specified in the permit;
 - (d) A description of any event which triggers the shut-off systems required in Section (K)(6) of this permit pursuant to 40 CFR 146.88(e), and the response taken;
 - (e) The monthly volume and/or mass of the carbon dioxide stream injected over the reporting period and the volume and/or mass injected cumulatively over the life of the project;
 - (f) Monthly annulus fluid volume added or produced; and
 - (g) Results of the continuous monitoring required in Section M(3) including:
 - (i) A tabulation of: (1) daily maximum injection pressure, (2) daily minimum annulus pressure, (3) daily minimum value of the difference between simultaneous measurements of annulus and injection pressure, (4) daily volume, (5) daily maximum flow rate, and (6) average annulus tank fluid level; and
 - (ii) Graph(s) of the continuous monitoring as required in Section M(3) of this permit, or of daily average values of these parameters. The injection pressure, injection volume and flow rate, annulus fluid level, annulus pressure, and temperature shall be submitted on one or more graphs, using contrasting symbols or colors, or in another manner approved by the Director; and
 - (h) Results of any additional monitoring identified in the Testing and Monitoring Plan and described in Section M of this permit.
3. **24-Hour Reporting** –
- (a) The permittee shall report to the Director any permit noncompliance which may endanger human health or the environment and/or any events that require implementation of actions in the Emergency and Remedial Response Plan (Attachment F of this permit). Any information shall be provided orally within 24 hours from the time the permittee becomes aware of the circumstances. Such verbal reports shall include, but not be limited to the following information:
 - (i) Any evidence that the injected carbon dioxide stream or associated pressure front may cause an endangerment to a USDW, or any monitoring or other information which indicates that any contaminant may cause endangerment to a USDW;
 - (ii) Any noncompliance with a permit condition, or malfunction of the injection system, which may cause fluid migration into or between USDWs;
 - (iii) Any triggering of the shut-off system required in Section (K)(6) of this permit (i.e., down-hole or at the surface);

- (iv) Any failure to maintain mechanical integrity;
 - (v) Pursuant to compliance with the requirement at 40 CFR 146.90(h) for surface air/soil gas monitoring or other monitoring technologies, if required by the Director, any release of carbon dioxide to the atmosphere or biosphere; and
 - (vi) Actions taken to implement appropriate protocols outlined in the Emergency and Remedial Response Plan (Attachment F of this permit).
- (b) A written submission shall be provided to the Director in an electronic format within five days of the time the permittee becomes aware of the circumstances described in Section(N)(3)(a) of this permit. The submission shall contain a description of the noncompliance and its cause; the period of noncompliance, including exact dates and times, and, if the noncompliance has not been corrected, the anticipated time it is expected to continue as well as actions taken to implement appropriate protocols outlined in the Emergency and Remedial Response Plan (Attachment F of this permit); and steps taken or planned to reduce, eliminate and prevent recurrence of the noncompliance.
4. **Reports on Well Tests and Workovers** – Report, within 30 days, the results of:
- (a) Periodic tests of mechanical integrity;
 - (b) Any well workover, including stimulation;
 - (c) Any other test of the injection well conducted by the permittee if required by the Director; and
 - (d) Any test of any monitoring well required by this permit.
5. **Advance Notice Reporting** –
- (a) **Well Tests** – The permittee shall give at least 30 days advance written notice to the Director in an electronic format of any planned workover, stimulation, or other well test.
 - (b) **Planned Changes** – The permittee shall give written notice to the Director in an electronic format, as soon as possible, of any planned physical alterations or additions to the permitted injection facility other than minor repair/replacement or maintenance activities. An analysis of any new injection fluid shall be submitted to the Director for review and written approval at least 30 days prior to injection; this approval may result in a permit modification.
 - (c) **Anticipated Noncompliance** – The permittee shall give at least 14 days advance written notice to the Director in an electronic format of any planned changes in the permitted facility or activity which may result in noncompliance with permit requirements.

6. **Additional Reports** –

- (a) **Compliance Schedules** – Reports of compliance or noncompliance with, or any progress reports on, interim and final requirements contained in any compliance schedule of this permit shall be submitted in an electronic format by the permittee no later than 30 days following each schedule date.
- (b) **Transfer of Permits** – This permit is not transferable to any person except after notice is sent to the Director in an electronic format at least 30 days prior to transfer and the requirements of 40 CFR 144.38(a) have been met. Pursuant to requirements at 40 CFR 144.38(a), the Director will require modification or revocation and reissuance of the permit to change the name of the permittee and incorporate such other requirements as may be necessary under the SDWA.
- (c) **Other Noncompliance** – The permittee shall report in an electronic format all other instances of noncompliance not otherwise reported with the next monitoring report. The reports shall contain the information listed in Section N(3)(b) of this permit.
- (d) **Other Information** – When the permittee becomes aware of failure to submit any relevant facts in the permit application or that incorrect information was submitted in a permit application or in any report to the Director, the permittee shall submit such facts or corrected information in an electronic format within 10 days in accordance with 40 CFR 144.51(1)(8).
- (e) **Report on Permit Review** – Within 30 days of receipt of this permit, the permittee shall certify to the Director in an electronic format that he or she has read and is personally familiar with all terms and conditions of this permit.

7. **Records** –

- (a) The permittee shall retain records and all monitoring information, including all calibration and maintenance records and all original chart recordings for continuous monitoring instrumentation and copies of all reports required by this permit (including records from pre-injection, active injection, and post-injection phases) for a period of at least 10 years from collection.
- (b) The permittee shall maintain records of all data required to complete the permit application form for this permit and any supplemental information (e.g. modeling inputs for AoR delineations and reevaluations, plan modifications) submitted under 40 CFR 144.27, 144.31, 144.39, and 144.41 for a period of at least 10 years after site closure.
- (c) The permittee shall retain records concerning the nature and composition of all injected fluids until 10 years after site closure.
- (d) The retention periods specified in Section N(7)(a) through (c) of this permit may be extended by request of the Director at any time. The permittee shall continue to retain records after the retention period specified in Section N(7)(a) through (c) of this permit

or any requested extension thereof expires unless the permittee delivers the records to the Director or obtains written approval from the Director to discard the records.

(e) Records of monitoring information shall include:

- (i) The date, exact place, and time of sampling or measurements;
- (ii) The name(s) of the individual(s) who performed the sampling or measurements;
- (iii) A precise description of both sampling methodology and the handling of samples;
- (iv) The date(s) analyses were performed;
- (v) The name(s) of the individual(s) who performed the analyses;
- (vi) The analytical techniques or methods used; and
- (vii) The results of such analyses.

O. WELL PLUGGING, POST-INJECTION SITE CARE, AND SITE CLOSURE

1. **Well Plugging Plan** – The permittee shall maintain and comply with the approved Well Plugging Plan (Attachment D of this permit) which is an enforceable condition of this permit and shall meet the requirements of 40 CFR 146.92.
2. **Revision of Well Plugging Plan** – If the permittee finds it necessary to change the Well Plugging Plan (Attachment D of this permit), a revised plan shall be submitted in an electronic format to the Director for written approval. Any amendments to the Well Plugging Plan must be approved by the Director and must be incorporated into the permit, and are subject to the permit modification requirements at 40 CFR 144.39 or 144.41.
3. **Notice of Plugging and Abandonment** – The permittee must notify the Director in writing in an electronic format pursuant to 40 CFR 146.92(c), at least 60 days before plugging, conversion or abandonment of a well. At the discretion of the Director, a shorter notice period may be allowed.
4. **Plugging and Abandonment Approval and Report** –
 - (a) The permittee must receive written approval of the Director before plugging the well and shall plug and abandon the well in accordance with 40 CFR 146.92, as provided in the Well Plugging Plan (Attachment D of this permit).
 - (b) Within 60 days after plugging, the permittee must submit in an electronic format a plugging report to the Director. The report must be certified as accurate by the permittee and by the person who performed the plugging operation (if other than the permittee.) The permittee shall retain the well plugging report in an electronic format for 10 years following site closure. The report must include:

- (i) A statement that the well was plugged in accordance with the Well Plugging Plan previously approved by the Director (Attachment D of this permit); or
 - (ii) If the actual plugging differed from the approved plan, a statement describing the actual plugging and an updated plan specifying the differences from the plan previously submitted and explaining why the Director should approve such deviation. If the Director determines that a deviation from the plan incorporated in this permit may endanger underground sources of drinking water, the permittee shall replug the well as required by the Director.
- 5. **Temporary Abandonment** – If the permittee ceases injection into the well for more than 24 consecutive months, the well is considered to be in a temporarily abandoned status, and the permittee shall plug and abandon the well in accordance with the approved Well Plugging Plan, 40 CFR 144.52 (a)(6), and 40 CFR 146.92, or make a demonstration of non-endangerment of this well while it is in temporary abandonment status. During any periods of temporary abandonment or disuse, the well will be tested to ensure that it maintains mechanical integrity, according to the requirements and frequency specified in Section L(2) of this permit. The permittee shall continue to comply with the conditions of this permit, including all monitoring and reporting requirements according to the frequencies outlined in the permit.
- 6. **Post-Injection Site Care and Site Closure Plan** –
 - (a) The permittee shall maintain and comply with the Post-Injection Site Care and Site Closure Plan, found as Attachment E of this permit, which meets the requirements of 40 CFR 146.93 and is an enforceable condition of this permit. The permittee shall:
 - (i) Upon cessation of injection, either submit in an electronic format for the Director’s approval an amended Post-Injection Site Care and Site Closure Plan or demonstrate through monitoring data and modeling results that no amendment to the plan is needed.
 - (ii) At any time during the life of the project, the permittee may modify and resubmit in an electronic format the Post-Injection Site Care and Site Closure Plan for the Director’s approval. The permittee may, as part of such modifications to the Plan, request a modification to the post-injection site care timeframe that includes documentation of the information at 40 CFR 146.93(c)(1).
 - (b) The permittee shall monitor the site following the cessation of injection to show the position of the carbon dioxide plume and pressure front and demonstrate that USDWs are not being endangered, as specified in the Post-Injection Site Care and Site Closure Plan and in 40 CFR 146.90, and 40 CFR 146.93, including:
 - (i) Ground water quality monitoring;
 - (ii) Tracking the position of the carbon dioxide plume and pressure front including direct pressure monitoring and geochemical plume monitoring and the use of indirect methods;

- (iii) Any other required monitoring, e.g., soil gas and/or surface air monitoring described in the Post-Injection Site Care and Site Closure Plan;
 - (iv) The permittee shall submit in an electronic format the results of all monitoring performed according to the schedule identified in the Post-Injection Site Care and Site Closure Plan; and
 - (v) The permittee shall continue to conduct post-injection site monitoring for at least 50 years or for the duration of any alternative timeframe approved pursuant to 40 CFR 146.93(c) and the Post-Injection Site Care and Site Closure Plan.
- (c) The post-injection monitoring must continue until the project no longer poses an endangerment to USDWs and the demonstration pursuant to 40 CFR 146.93(b)(2) and as described in Section O(5)(c) of this permit is approved by the Director.
- (d) Prior to authorization for site closure, the permittee shall submit to the Director for review and approval, in an electronic format, a demonstration, based on information collected pursuant to Section O(5)(b) of this permit, that the carbon dioxide plume and the associated pressure front do not pose an endangerment to USDWs and that no additional monitoring is needed to ensure that the project does not pose an endangerment to USDWs, as required under 40 CFR 146.93(b)(3). The Director reserves the right to amend the post-injection site monitoring requirements (including extend the monitoring period) if the carbon dioxide plume and the associated pressure front have not stabilized or there is a concern that USDWs are being endangered.
- (e) The permittee shall notify the Director in an electronic format at least 120 days before site closure. At this time, if any changes to the approved Post-Injection Site Care and Site Closure Plan in Attachment E of this permit are proposed, the permittee shall submit a revised plan.
- (f) After the Director has authorized site closure, the permittee shall plug all monitoring wells as specified in Attachment E of this permit – the Post-Injection Site Care and Site Closure Plan – in a manner which will not allow movement of injection or formation fluids that endangers a USDW. The permittee shall also restore the site to its pre-injection condition.
- (g) The permittee shall submit a site closure report in an electronic format to the Director within 90 days of site closure. The report must include the information specified at 40 CFR 146.93(f).
- (h) The permittee shall record a notation on the deed to the facility property or any other document that is normally examined during a title search that will in perpetuity provide any potential purchaser of the property the information listed at 40 CFR 146.93(g).
- (i) The permittee shall retain for 10 years following site closure an electronic copy of the site closure report, records collected during the post-injection site care period, and any

other records required under 40 CFR 146.91(f)(4). The permittee shall deliver the records in an electronic format to the Director at the conclusion of the retention period.

P. EMERGENCY AND REMEDIAL RESPONSE

1. The Emergency and Remedial Response Plan describes actions the permittee must take to address movement of the injection or formation fluids that may cause an endangerment to a USDW during construction, operation, and post-injection site care periods. The permittee shall maintain and comply with the approved Emergency and Remedial Response Plan (Attachment F of this permit), which is an enforceable condition of this permit, and with 40 CFR 146.94.
2. If the permittee obtains evidence that the injected carbon dioxide and/or associated pressure front may cause endangerment to a USDW, the permittee must:
 - (a) Cease injection in accordance with Sections K(8) and K(9)(a) or (b), and Attachments A or F of this permit;
 - (b) Take all steps reasonably necessary to identify and characterize any release;
 - (c) Notify the Director within 24 hours; and
 - (d) Implement the Emergency and Remedial Response Plan (Attachment F of this permit) approved by the Director.
3. At the frequency specified in the Area of Review and Corrective Action Plan, or more frequently when monitoring and operational conditions warrant, the permittee shall review and update the Emergency and Remedial Response Plan as required at 40 CFR 146.94(d) or demonstrate to the Director that no update is needed. The permittee shall also incorporate monitoring and operational data and in response to AoR reevaluations required under Section G.2. of this permit or demonstrate to the Director that no update is needed. The amended Emergency and Remedial Response Plan or demonstration shall be submitted to the Director in an electronic format within one year of an AoR reevaluation; following any significant changes to the facility such as addition of injection wells; or when required by the Director.
4. Following each update of the Emergency and Remedial Response Plan or a demonstration that no update is needed, the permittee shall submit the resultant information in an electronic format to the Director for review and confirmation of the results. Once approved by the Director, the revised Emergency and Remedial Response Plan will become an enforceable condition of this permit.

Q. COMMENCING INJECTION

The permittee may not commence injection until:

1. Results of the formation testing and logging program as specified in Section J of this permit and in 40 CFR 146.87 are submitted to the Director in an electronic format and subsequently reviewed and approved by the Director;
2. Mechanical integrity of the well has been demonstrated in accordance with 40 CFR 146.89(a)(1) and (2), and in accordance with Section L(1) through (3) of this permit;
3. The completion of corrective action required by the Area of Review and Corrective Action Plan found in Attachment B of this permit in accordance with 40 CFR 146.84;
4. All requirements at 40 CFR 146.82(c) have been met, including but not limited to reviewing and updating of the Area of Review and Corrective Action, Testing and Monitoring, Well Plugging, Post-Injection Site Care and Site Closure, and Emergency and Remedial Response plans to incorporate final site characterization information, final delineation of the AoR, and the results of pre-injection testing, and information has been submitted in an electronic format, reviewed and approved by the Director;
5. Construction is complete and the permittee has submitted to the Director in an electronic format a notice that completed construction is in compliance with 40 CFR 146.86 and Section I of this permit;
6. The Director has inspected or otherwise reviewed the injection well and all submitted information and finds it is in compliance with the conditions of the permit;
7. The Director has approved demonstration of the alarm system and shut-off system under Section K.6 of this permit; and.
8. The Director has given written authorization to commence injection.

ATTACHMENTS

These attachments include, but are not limited to, permit conditions and plans concerning operating procedures, monitoring and reporting, as required by 40 CFR Parts 144 and 146. The permittee shall comply with these conditions and adhere to these plans as approved by the Director, as follows:

- A. SUMMARY OF OPERATING REQUIREMENTS**
- B. AREA OF REVIEW AND CORRECTIVE ACTION PLAN**
- C. TESTING AND MONITORING PLAN**
- D. WELL PLUGGING PLAN**
- E. POST-INJECTION SITE CARE AND SITE CLOSURE PLAN**
- F. EMERGENCY AND REMEDIAL RESPONSE PLAN**
- G. CONSTRUCTION DETAILS**
- H. FINANCIAL ASSURANCE DEMONSTRATION**
- I. STIMULATION PROGRAM**

ATTACHMENT A: SUMMARY OF REQUIREMENTS

CLASS VI OPERATING AND REPORTING CONDITIONS

Facility name: Archer Daniels Midland, CCS#2 Well
 IL-115-6A-0001
 4666 Faries Parkway, Decatur, IL

Well location: Decatur, Macon County, IL;
 39°53'09.32835", -88°53'16.68306"

Injection Well Operating Conditions

| PARAMETER/CONDITION | LIMITATION or PERMITTED VALUE | UNIT |
|---|--------------------------------------|-------------|
| Maximum Injection Pressure - Surface | 2284 | psig |
| Minimum Annulus Pressure | 100 | psig |
| Minimum Annulus Pressure/Tubing Differential (directly above and across packer) | 100 | psig |

The injection pressure will be measured at the wellhead.

The maximum injection pressure, which serves to prevent confining-formation fracturing, was determined using the fracture gradient obtained from injectivity data from the nearby CCS#1 well multiplied by 0.9 (146.88 (a)).

Routine Shutdown Procedure:

Under routine conditions (e.g., for well workovers), the permittee may immediately cease injection and shut-in the well. Alternatively, the permittee may gradually reduce the injection rate of CO₂ as warranted to ensure protection of health, safety, and the environment. (Procedures that address immediately shutting in the well are in Attachment F (Emergency and Remedial Response Plan) of this permit).

Class VI Injection Well Reporting Frequencies

| ACTIVITY | MINIMUM REPORTING FREQUENCY |
|--|--------------------------------------|
| CO ₂ stream characterization | Semi-annually |
| Pressure, flow, rate, volume, pressure on the annulus, annulus fluid level and temperature | Semi-annually |
| Corrosion monitoring | Semi-annually |
| External MIT | Within 30 days of completion of test |
| Pressure fall-off testing | In the next semi-annual report |

Note: All testing and monitoring frequencies and methodologies are included in Attachment C (the Testing and Monitoring Plan) of this permit.

Class VI Project Reporting Frequencies

| ACTIVITY | MINIMUM REPORTING FREQUENCY |
|--|--------------------------------------|
| Ground water quality monitoring | Semi-annually |
| Plume and pressure front tracking | In the next semi-annual report |
| Surface air and/or soil gas monitoring | In the next semi-annual report |
| Monitoring well MITs | Within 30 days of completion of test |
| Financial Responsibility updates pursuant to H.2 and H.3(a) of this permit | Within 60 days of update |

Note: All testing and monitoring frequencies and methodologies are included in Attachment C (the Testing and Monitoring Plan) of this permit.

Start-up Monitoring and Reporting Procedures

These additional procedures describe how ADM will: A) initiate injection as detailed in the table below and conduct start-up specific monitoring of the CCS#2 site pursuant to 40 CFR 146.90 and B) submit monthly reports during the first six months of injection.

A) Multi-stage (step-rate) start-up procedure and start-up period¹:

1) This procedure will be done using the existing surface and downhole pressure and temperature gauges in CCS#2, CCS#1, VW#1, VW#2, and GM#2.

2) During the start-up period the permittee will submit a daily report summarizing and interpreting the operational data. At the agency's request, the permittee will schedule a daily conference call to discuss the operational data.

3) A series of successively higher injection rates have been determined as shown in the table below, and the elapsed time and pressure values are read and recorded for each rate and time step. Each rate step will last 24 hours. At no point during the procedure will the injection pressure exceed the maximum injection pressure (2284 psig) measured at the wellhead.

4) A spinner log will be conducted during each change (step) in rate.

5) Planned Injection Rates:

| Rate (Tonnes per day) | Duration (hrs.) | Percent of Permit Maximum Injection Rate (%) |
|---|-----------------|--|
| 550 | 24 | 16.7% |
| 1100 | 24 | 33.3% |
| 1650 | 24 | 50.0% |
| 2200 | 24 | 66.7% |
| 2750 (or max. available CO ₂) | 24 | 83.3% |

¹ Applies only to the initial start of injection operations until the well reaches full injection rate.

6) Injection rates will be controlled by starting an additional compressor (fix volume with no spillback); thus, the flow will remain constant throughout the duration of the step rate period.

7) Injection rates will be measured (using the Coriolis flow meter) and data will be recorded.

8) Surface and downhole pressure and temperatures will be measured and data will be recorded at CCS#2, CCS#1, VW#1, VW#2, and GM#2.

9) During the startup period, a plot of injection rates and the corresponding stabilized pressure values will be graphically represented. During the start-up period, the project team will look for any evidence of anomalous pressure behavior.

10) If during the start-up period, anomalous pressure behavior is observed, the project team may conduct additional logging and modify the injection rate to better characterize the anomaly.

11) If during the start-up period, the project team determines that anomalous pressure behavior indicates formation fracturing, injection will be stopped and the line valve closed allowing the pressure to bleed-off into the injection zone.

- a. The instantaneous shut-in pressure (ISIP), will be measured and the microseismic data will be reviewed for event signatures.
- b. The permittee will notify the agency within 24 hours of the determination.
- c. The permittee will consult with the agency before initiating further injection.

B) Additional Start-up Monthly Monitoring and Reporting²:

On a monthly basis, during the first six (6) months of injection, the permittee will provide the agency with a report that summarizes and provides interpretation of the microseismic and operating data described above in Part A of this section. The report shall be submitted within 30 days after the end of the reporting period.

² During the first six months of injection.

ATTACHMENT B: AREA OF REVIEW AND CORRECTIVE ACTION PLAN

Facility Information

Facility name: Archer Daniels Midland, CCS#2 Well
IL-115-6A-0001
4666 Faries Parkway, Decatur, IL

Well location: Decatur, Macon County, IL;
39°53'09.32835", -88°53'16.68306"

Computational Modeling

Model Name and Authors/Institution

ECLIPSE 300 (v2011.2) reservoir simulator with the CO2STORE module, Schlumberger.

Description of Model

Model Description

ECLIPSE 300 is a compositional finite-difference solver that is commonly used to simulate hydrocarbon production and has various other applications including carbon capture and storage modeling. The CO2STORE module accounts for the thermodynamic interactions between three phases: an H₂O-rich phase (i.e., 'liquid'), a CO₂-rich phase (i.e., 'gas'), and a solid phase, which is limited to several common salt compounds (e.g. NaCl, CaCl₂, and CaCO₃). Mutual solubilities and physical properties (e.g. density, viscosity, enthalpy, etc.) of the H₂O and CO₂ phases are calculated to match experimental results through a range of typical storage reservoir conditions, including temperature ranges between 12°C-100°C and pressures up to 60 MPa. Details of this method can be found in Spycher and Pruess (2005). Additional assumptions governing the phase interactions throughout the simulations are as follows:

- The salt components may exist in both the liquid and solid phases.
- The CO₂-rich phase (i.e., 'gas') density is obtained by using the Redlich-Kwong equation of state. The model was accurately tuned and modified as further described below (Redlich and Kwong, 1949).
- The brine density is first approximated as pure water then corrected for salt and CO₂ concentration by using Ezrokhi's method (Zaytsev and Aseyev, 1992).
- The CO₂ gas viscosity is calculated per the methods described by Vesovic et al. (1990) and Fenghour et al. (1999).

The gas density was obtained using a modified Redlich-Kwong equation of state following a method developed by Spycher and Pruess, where the attraction parameter is made temperature dependent:

$$P = \left(\frac{RT_K}{V - b_{mix}} \right) - \left(\frac{a_{mix}}{T_K^{1/2} V (V + b_{mix})} \right)$$

where V is the molar volume, P is the pressure, T_K is the temperature in Kelvin, R is the universal gas constant, and a_{mix} and b_{mix} are the attraction and repulsion parameters.

The transition between liquid CO₂ and gaseous CO₂ can lead to rapid density changes of the gas phase; the simulator uses a narrow transition interval between the liquid and gaseous density to represent the two phase CO₂ region.

Because the compression facility controls the CO₂ delivery temperature to the injection well between 80°F and 120°F, the temperature of the injectate will be comparable to the reservoir formation temperature within the injection interval. Therefore, the simulations were carried out based on isothermal operating conditions. With respect to time step selection, the software algorithm optimizes the time step duration based on specific convergence criteria designed to minimize numerical artifacts. For these simulations, time step size ranged from 8.64x10¹ to 8.64x10⁵ seconds or 0.001 to 10 days. In all cases, the maximum solution change over a time step is monitored and compared with the specified target. Convergence is achieved once the model reaches the maximum tolerance where small changes of temperature and pressure calculation results occur on successive iterations. New time steps are chosen so that the predicted solution change is less than a specified target.

Description of AoR Delineation Modeling Effort

The 3D geologic model developed for the initial injection simulations was based on the interpretation of a diverse collection of geological, geophysical, and petrophysical data acquired throughout the construction of the IBDP wells (CCS#1 and VW#1). Structurally, the model is also based on the interpretation of both two dimensional (2D) and three dimensional (3D) seismic survey data in conjunction with dipmeter log data acquired from the IBDP wells. Petrophysical and transport properties based on the interpreted well log data and the analysis of core samples recovered from the IBDP wells were then distributed throughout each layer in the geocellular model. Following the collection of testing and logging data during construction and pre-operational testing of CCS#2 and VW#2, the geologic model was updated pursuant to 40 CFR 146.82(c)(1).

The original, pre-construction phase model implemented porosity and permeability well logs from CCS#1, VW#1, and VW#2. Seismic inversion was performed on the 3D surface seismic cube resulting in a seismic porosity cube. This seismic porosity cube was integrated with logs to guide interpolation of porosity throughout the 3D model. For the Mt. Simon, the PorosityCube was sampled into the geomodel's 3D grid and was also used to describe lateral heterogeneity beyond the seismic survey's footprint. A workflow was prepared to document log upscaling and property modeling. To update the reservoir model following pre-injection testing, logs from CCS#2 were used to update the 3D geologic model to reflect new information while remaining true to the original seismic property-driven distributions that did not require updates. The following steps were followed to incorporate CCS#2 well log data into the model domain permeability and porosity distributions:

1. Log (ELAN) permeability curves were upscaled into the static geologic model.
2. Permeability was log transformed.
3. General distribution was developed from log-permeability data.
4. The log permeability distribution was updated through co-simulation of VW#2 and CCS#2 log-permeability data with the existing 3D model log-permeability distribution and using the general log-permeability pdf developed from the data. The result honors the new log data at and near the wells and honors the seismic driven distribution as a trend away from VW#2 and CCS#2.
5. Permeability was inverse log transformed.
6. Steps 3 through 5 were done on a zone-by-zone basis.
7. The new permeability distribution was upscaled into a reservoir model grid and the existing permeability distribution for the CCS#2 injection zone was replaced with the newly computed permeability distribution within the CCS#2 injection zone across the entire lateral extent of the reservoir model grid.

In November 2011, injection of CO₂ into CCS#1 began and, as of project completion in November 2014, 999,215 metric tons of CO₂ had been injected. Operational data from this project was used to calibrate the reservoir model being used for both the IBDP and IL-ICCS projects. Data obtained includes injection well bottom hole pressure (BHP), multi-zone pressure data from VW#1, Spinner data, i.e. injection profile logs in CCS#1, and reservoir saturation tools (RST) from both IBDP wells. These datasets have provided additional information to allow calibration of various reservoir parameters including intrinsic permeabilities, relative permeabilities, wellbore skin values, vertical to horizontal permeability ratios, and rock compressibility. These calibrations allow the model to be updated periodically to improve the accuracy between the model prediction versus the actual result.

Monitoring data used for pressure matching includes:

- Injection rate;
- Injection bottom hole pressure – real-time data collected from a down hole gauge in the injection well about 600 ft above the perforations;
- Westbay multilevel ground water characterization and monitoring system pressures – real-time pressures located at specific zones in the verification well 1000 ft. north of the injection well. Five out of ten zones were used for model calibration;
- Spinner data-flow partitioning between perforations – log run in injection well through March 2013; and
- RST well logs – CO₂ saturations around CCS#1 and VW#1 – logs run through March 2013.

More detailed information on model inputs and assumptions is given in the following subsections.

Model Inputs and Assumptions

The geologic/hydrogeologic and operational information that serve as inputs to the model are described in the following subsections. The model update meets the requirements of 40 CFR 146.82(c)(1) and simulates three years of injection in CCS#1, followed by five years of injection in CCS#2, followed by a 50-year post-injection period.

Site Geology and Hydrology

The Class VI well targets an injection zone in the Cambrian Mt. Simon Sandstone of the Illinois Basin (see coordinates above under “Facility Information”). Information on the injection and confining zones was collected during the drilling and testing of the nearby IBDP injection well CCS#1, as well as existing Illinois State Geological Survey (ISGS) studies and reports. Data from an ISGS database of core sample data and additional core sample analyses from sites within approximately 30–80 miles of the injection well were also used. Wireline log results from CCS#2 and VW#2 and core analyses from VW#2 were compared to data collected from CCS#1 and the ISGS database. The results show good agreement, validating the local site geology and hydrogeology as defined by data from CCS#1 and other nearby wells.

The Mt. Simon Sandstone is the first formally recognized sedimentary unit overlying the Precambrian granitic basement rock. The depositional environment of the Mt. Simon has “commonly been interpreted to be a shallow, sub-tidal marine environment,” based on surface study of the upper Mt. Simon or studies of Wisconsin or Ozark Dome outcrops. However, based on core sample and log analysis from the CCS#1 well, and verified from pre-injection testing on CCS#2 and VW#2, the upper Mt. Simon is interpreted to have been deposited “in a tidally influenced system similar to the reservoirs used for natural gas storage in northern Illinois,” while the basal 600 ft (the target injection zone) represents an “arkosic sandstone that was originally deposited in a braided river-alluvial fan system.” In this lower zone, “abundant amounts” of secondary porosity occur due to the dissolution of feldspar grains. A sedimentary interval known as the “pre-Mt. Simon” is present at the base of the Mt. Simon, bounded by a disconformity (between the Mt. Simon and the pre-Mt. Simon). The pre-Mt. Simon is lithologically similar to the Mt. Simon but with significantly lower porosity and permeability than the overlying Mt. Simon (Freiburg, Morse, Leetaru, Hoss and Yan, 2014).

Directly overlying the Mt. Simon Sandstone is the Cambrian Eau Claire Formation. Based on data from CCS#1, in the area of the injection well, the Eau Claire consists of a basal shale layer overlain by very fine-grained limestone interbedded with thin siltstone layers. The Eau Claire serves as a confining zone for gas storage projects elsewhere in the Illinois Basin. Two other regional shale units are identified as secondary confining zones—the Ordovician Maquoketa Formation and the Devonian New Albany Shale—though these units lie above the lowermost USDW. No resolvable faults or folds were identified in the injection or confining zones based on 3D seismic data collected in 2011. Pre-injection testing in CCS#2 and VW#2 confirmed the absence of faults and folds based on the results of fracture finder logs.

Only limited data and modeling results are available on ground water flow in the deep Illinois Basin, which is based on modeling results from Gupta and Bair (1997). Flow patterns in the Mt. Simon are “influenced by the geologic structure with flow away from arches such as the

Kankakee Arch and toward the deeper parts of the Illinois Basin.” In the model, an initial fluid pressure of 3,205 psi (at elevation -6,345 ft MSL), an initial temperature of 112°F (at elevation - 5,365 ft MSL; gradient 1°F/ft), and an initial salinity of 200,000 ppm were used. MSL is defined as mean sea level. Like other areas with humid climates (Freeze and Cherry, 1979), the water table in central Illinois is expected to reflect the elevation of the land surface. Steady-state ground water flow modeling for the IBDP site indicates that shallow ground water flows toward the east and southeast toward the Sangamon River and Lake Decatur.

The lowermost USDW is the Ordovician St. Peter Sandstone, based on TDS sampling of the upper St. Peter during the drilling of CCS#1.

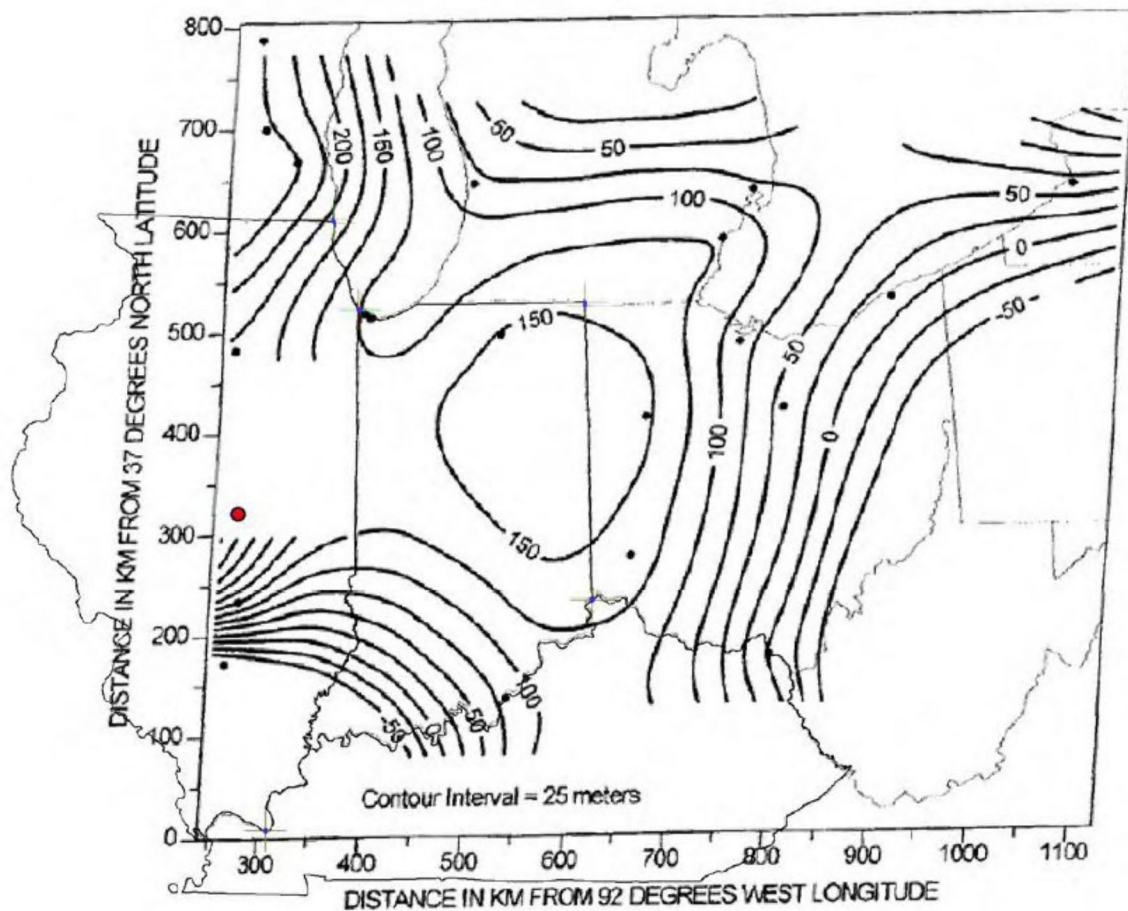

Figure 1. Observed head in the Mt. Simon Sandstone. The red dot represents the location of CCS#1 (potentiometric surface = 76 m/249 ft above mean sea level).

Model Domain

The static geological model includes the entire Mt. Simon and the overlying seal (the Eau Claire), spanning a 40 × 40 mile area. The final reservoir model was represented by a 146 × 146 × 148 grid in a Cartesian system with 146 grid points in the x-direction, 146 grid points in the y-direction, and 148 grid points in the z-direction, for a total of 3,154,768 grid points. Model domain information is summarized in Table 1.

Table 1. Model domain information.

| | | | |
|--------------------------------------|--------------|--------------------------------------|--------------|
| Coordinate System | State Plane | | |
| Horizontal Datum | NAD27 | | |
| Coordinate System Units | ft | | |
| Zone | SPCS27-1201 | | |
| FIPZONE | 1,201 | ADSZONE | 3,776 |
| Coordinate of x_{min} | 277,028.18 | Coordinate of x_{max} | 408,692.78 |
| Coordinate of y_{min} | 1,103,729.25 | Coordinate of y_{max} | 1,235,364.89 |
| Coordinate of z_{min} | -7113.19 | Coordinate of z_{max} | -4272.78 |

Porosity

Injection Zone Porosity

The total porosity of the injection zone was determined based on neutron and density logs of CCS#2, while effective porosity was determined from helium porosimetry on a “limited number” of core samples. The results of these methods compared well to each other, and so neutron-density crossplot porosity was used to approximate effective porosity. Pre-injection testing in CCS#2 identified an optimal injection interval of 6,630 to 6,825 ft KB, with multiple perforations of 6,630 – 6,670; 6,680 – 6,725; 6,735 – 6,775; and 6,781 – 6,825 (all in ft KB). The AoR was modeled using these perforation intervals, with an average effective porosity throughout the injection zone of 22%. Within the AoR, KB (Kelly Bushing) is approximately 682 ft above MSL.

Additionally, the open-hole log based porosity was classified using Schlumberger Elemental Log Analysis (ELAN) as described in the CCS#2 Geophysical Log Descriptive Report. In the log analysis, the log analyst stated that the lower zone of the Mt. Simon has an average porosity of 22%, though there are intervals where the porosity approaches 30%.

Based on the analysis of log results from CCS#2, ADM identified five porosity/permeability zones within the Mt. Simon. These zones, with the average porosity and permeability values indicated by ADM, are illustrated in Figure 2. Pre-injection testing identified a high porosity/permeability region extending from the base of the Mt. Simon at 7,043 ft KB up to 6,427 ft KB; this overall interval included two sub-units with similar but varying porosity and permeability. The middle section of the Mt. Simon had lower porosity and permeability, extending from 6,427 to 5,907 ft KB. The upper unit from 5,907 to 5,553 ft KB also has high porosity and permeability, but was determined to be too close to the confining zone for injection.

Confining Zone Porosity

The median porosity of the Eau Claire Formation is 4.7%, based on information from an ISGS database of UIC well core samples. Pre-injection testing in CCS#2 and VW#2 indicated very small pore sizes based on CMR data, resulting in generally very low permeability (see “Confining Zone Permeability” below).

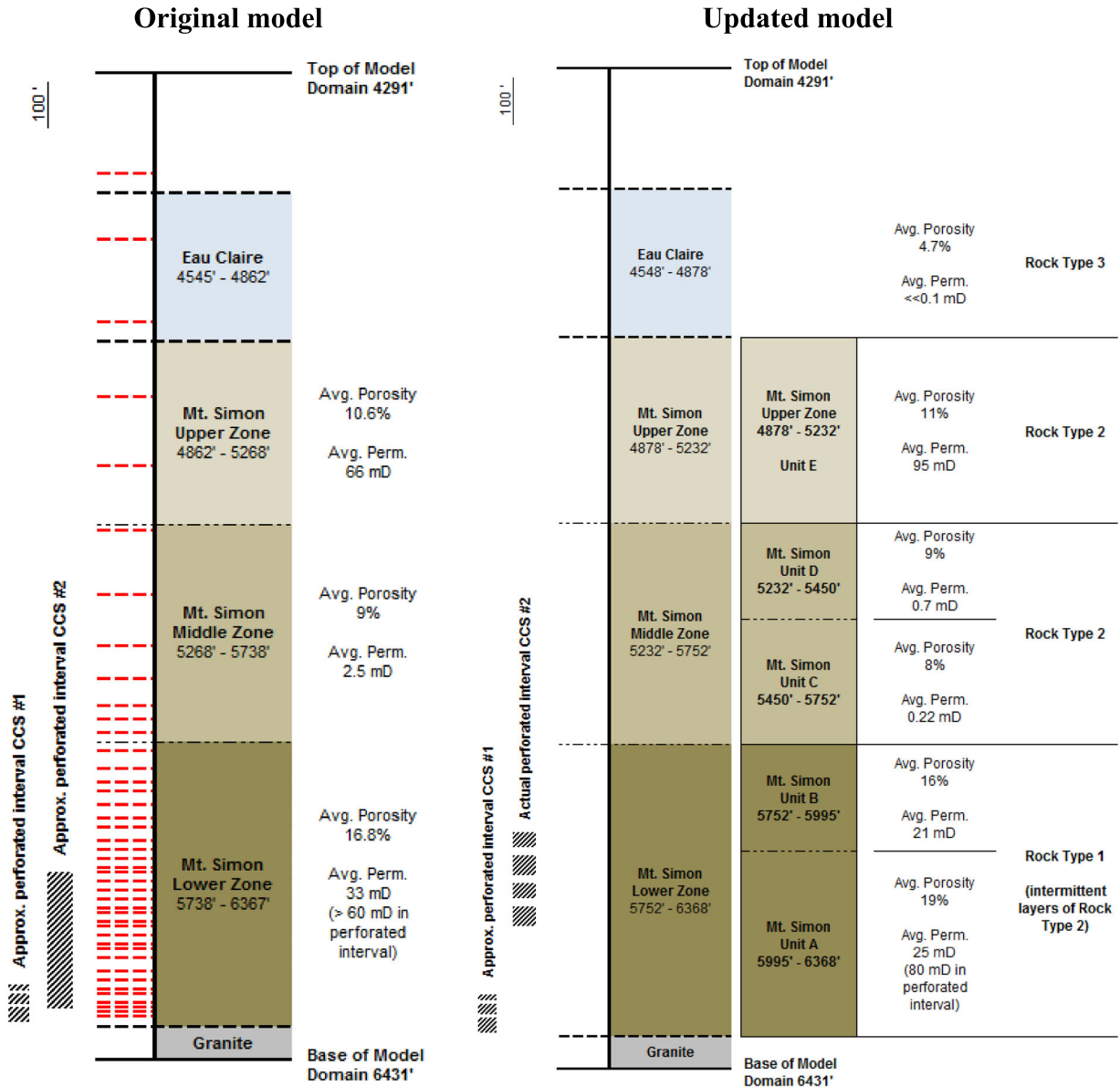

Figure 2. Reproduced layers of the geologic model and average porosity/permeability values, as identified by ADM based on log analysis, along with the approximate screened intervals of CCS #1 and CCS #2. The column on the left was produced during evaluation of the final AoR model prior to pre-injection testing; the right column incorporates the results of geophysical testing in CCS#2 and VW#2 during pre-injection testing. The updated column shows both the three primary rock types and the five rock types indicated by the wireline logs. The pre-Mt. Simon, not discretely depicted, is accommodated in the model as the four lowest layers of the model (i.e., the base of Mt. Simon Lower Zone/Mt. Simon Unit A in this Figure). Horizontal distances are not to scale, and the representation of layer thickness is approximate.

Permeability

Injection Zone Permeability

For the pre-construction modeling effort, ADM determined intrinsic permeability for areas of the injection zone based on available core analyses and CCS#1 well testing results, and developed a

core porosity-permeability transform based on grain size to estimate permeability over intervals without core samples. From this method, ADM calculated a geometrical average intrinsic permeability of 194 mD for the CCS#1 injection interval. In the updated modeling effort following pre-operational testing and logging, ADM incorporated the logging and core analyses in CCS#2 and VW#2 using the methods described earlier in this plan. The well log data collected during pre-operational testing were simulated with the existing 3D permeability distribution to develop a new geological model.

ADM also reported additional permeability values based on pressure transient analysis of data from CCS#1 pressure fall-off tests. Using PIE pressure transient software, ADM estimated permeability of 185 mD over 75 ft of vertical thickness in the injection zone. ADM also directly calculated permeability for this interval from core samples and well log analyses, with a result of 80 mD in the perforated interval. Multiple regions in the perforated interval had much higher permeability (above 100mD), as shown in Figure 2.

Confining Zone Permeability

During pre-operational testing, ADM collected 33 horizontal and 3 vertical whole core samples, and 2 rotary sidewall core samples, all from VW#2. Three hundred fifty-one (351) core plugs were drilled from the whole core collected from VW#2 and were suitable for routine core property measurements. The rock properties derived from these samples were primarily used to validate and calibrate the ELAN petrophysical model based on well logs. While no core samples were taken from the shale zone of the Eau Claire A at VW#2, 36 plugs of the upper interval Eau Claire C (very fine sandstone, microcrystalline limestone, and siltstone) were available for testing. Of the plugs tested for vertical permeability, the average permeability was 0.036 mD. While no core samples were taken from the shale zone of the Eau Claire A at CCS#1, 12 plugs of the lower portion of the upper interval Eau Claire B/C (very fine sandstone, microcrystalline limestone, and siltstone) were available for testing. Average horizontal permeability for these sidewall rotary core samples was determined to be 0.000344 mD. However, the vertical permeability of the actual shale interval is expected to be much lower because vertical permeability of plugs “is generally lower than horizontal permeability and shale permeability is generally much lower than sandstone, limestone, and siltstone.” Based on the analysis of log results from CCS#1 and confirmed by well logs in CCS#2, the Eau Claire, extending from the top of the Mt. Simon to -4,545 ft MSL (-5,227 ft KB), is described as having “only a few small intervals of less than a few feet that have any permeability greater than 0.1 mD,” which do not appear to be continuous.

ADM also cited a median permeability value of 0.000026 mD from the ISGS UIC core database. In addition, based on a set of core samples from a site approximately 80 miles to the north of the proposed Class VI location, of the 110 analyses conducted, most were in the range of < 0.001 to 0.001 mD, with five in the range of 0.100 to 0.871 mD (the maximum value in the data set). This indicates that even the more permeable beds in the Eau Claire Formation are expected to be relatively tight and tend to act as sealing lithologies.

Operational Information

The proposed injection well, CCS#2, is part of the IL-ICCS project. The other CO₂ injection well on ADM’s property, IDBP well CCS#1, was completed in 2009. The AoR modeling accounts for both injection operations, and the details are presented in **Error! Reference source not found.**

Table 2. Operating details for CCS#1 and CCS#2, as used in the model.

| Parameters and units | | CCS#1 | | | CCS#2 | | | |
|--|---------|--------------|------|------|--------------|------|------|------|
| Model coordinates (ft) | X | 342,848.58 | | | 344,366.37 | | | |
| | Y | 1,169,545.00 | | | 1,172,887.91 | | | |
| Screened intervals | | 3 | | | 4 | | | |
| Screen depth (ft, KB = 682 ft) | Ztop | 6976 | 6982 | 7024 | 6630 | 6680 | 6735 | 6787 |
| | Zbottom | 6978 | 7012 | 7050 | 6670 | 6725 | 6775 | 6825 |
| Screen elevation (ft) | Ztop | 6294 | 6300 | 6342 | 5948 | 5998 | 6053 | 6105 |
| | Zbottom | 6296 | 6330 | 6368 | 5988 | 6043 | 6093 | 6143 |
| Screened interval length (ft) | | 2 | 30 | 26 | 40 | 45 | 40 | 38 |
| Wellbore diameter (in.) | | 12.25 | | | 12.25 | | | |
| Injection duration (years) | | 3 | | | 5 | | | |
| Injection rate (MMT/year) | | 0.333 | | | 1 | | | |
| Fracture gradient (psi/ft) | | 0.715 | | | 0.715 | | | |
| Max. injection pressure, as submitted (psi) | | 5,024 | | | 4,266 | | | |
| Elevation (subsurface depth - KB) corresponding to max. pressure, as submitted by ADM (ft) | | 6,343 | | | 6,630 | | | |
| Max. injection pressure (90% of frac. pres.) at the top of the screened interval, calculated from frac. gradient (psi) | | 4,489.06 | | | 4,266.41 | | | |
| Subsurface elevation at the top of the screened interval, calculated from frac. gradient (ft) | | 6,976 | | | 6,630 | | | |

Fracture Pressure and Fracture Gradient

Injection Zone

A step rate test at CCS#1, in the interval of -7,025 ft KB to -7,050 ft KB was conducted to estimate the fracture pressure of the injection zone. The result from the uppermost perforation of CCS#1 (-7,025 ft KB) was 5,024 psig, corresponding to a fracture gradient of 0.715 psi/ft. Based on this result, ADM estimated the maximum injection pressure for CCS#1 as 3,995 psi based on the calculated fracture pressure at -6,345 ft MSL. As shown in Table 2, the elevation that

corresponds to the top of the injection interval at CCS#1 is -6,283 ft MSL, which corresponds to a fracture pressure of 4,398.1 psi using the 0.7 psi/ft fracture gradient. Therefore, a maximum injection pressure of 3,958.29 psi at the top of the perforated interval (90% of the fracture pressure) is used for CCS#1.

Using the same approach for CCS#2, the maximum injection pressure value is calculated to be 4,266 psi at elevation -6,630 ft MSL. Similarly, the maximum injection pressure is calculated for the top of the injection interval, which corresponds to an elevation of -5,948 ft MSL. Based on the fracture gradient of 0.715, the maximum injection pressure at this point is calculated to be 3,792.6 psi. These values are given in **Error! Reference source not found.** above.

It was determined that these values (calculated based on CCS#1 results) accurately represent the system and will continue to be used for the fracture gradient and fracture pressure for CCS#2, until and unless more accurate project-specific data are available. A step-rate test run after the construction of CCS#2 yielded results that do not contradict initial fracture pressure gradient estimates, although some testing did produce inconclusive results. Injection pressure limits based upon this fracture pressure gradient should not create new fractures or extend any existing fractures. However, additional precautions for initial injection operations and monitoring have been added to Attachment A of this permit.

Confining Zone

A “mini-frac” field test was used to determine in-situ fracture pressure in the confining zone. Fracture pressure results (from four short-term injection/fall-off test periods, 15 to 60 minutes each) ranged from 5,078 to 5,324 psig, corresponding to a fracture gradient ranging from 0.93 to 0.98 psi/ft in the Eau Claire shale zone.

Initial Conditions

Fluid sampling and testing were conducted in August 2015 in VW#2, including in-situ measurements of formation pressure and temperature and the collection of eight fluid samples at five depths. A temperature log was run in CCS#2 in 2015. The results are as follows:

- Temperature increased consistently with depth from 60 °F at 50’ to 100 °F at 6,950 KB with an average temperature gradient of 0.0058 °F/ft.
- Formation pressure was 3,200 psi at 6,980 KB with a pressure gradient of 0.46 psi/ft. The pressure ranged from 2,626 psi at 5,848 KB to 3,211 psi at 7,041 KB.
- Fluid density ranged from 1,101 g/L to 1,136 g/L, with an average of 1,124 g/L (of the four samples collected).
- TDS ranged from 149,830 ppm at 5,848 KB to 199,950 ppm at 7,041 KB with an average of 184,053 ppm (of the four samples collected).

Original initial condition information submitted by ADM during permitting:

- Temperature ranged from 119.8°F at 5,772 ft to 125.8°F at 6,912 ft.
- Formation pressure ranged from 2,583 psi at 5,772 ft to 3,206 psi at 7,045 ft.
- Fluid density ranged from 1,090 g/L to 1,137 g/L, with an average of 1,119 g/L (of the five samples taken).
- TDS ranged from 164,500 ppm at 5,772 ft to 228,100 ppm at 7,045 ft, with an average of 196,700 ppm.

The values presented above from pre-operational testing activities are consistent with the values presented in the initial permit application and pre-construction modeling effort.

Boundary Conditions

No-flow boundary conditions were applied to the upper and lower boundaries of the model, with the assumption that the reservoir and the caprock are continuous throughout the region. A pore volume multiplier of 10,000 was applied to each cell in the horizontal boundaries of the ECLIPSE model in order to simulate an extensive reservoir. The horizontal boundaries were selected as: hydrostatic initial conditions for the aqueous phase, no-flow conditions for the gas phase, and initial conditions for salt. No changes were made to the boundary conditions following pre-operational testing.

AoR Pressure Front Delineation

To delineate the pressure front, the minimum or critical pressure ($P_{i,f}$) necessary to reverse flow direction between the lowermost USDW and the injection zone—and thus cause fluid flow from the injection zone into the formation matrix—must be calculated. ADM calculated $P_{i,f}$ using the method provided in the March 2011 draft of the *UIC Program Class VI Well Area of Review and Corrective Action Evaluation Guidance*, where the pressure front is given by:

$$P_{i,f} = P_u \cdot \frac{\rho_i}{\rho_u} + \rho_i g \cdot (z_u - z_i)$$

Where:

- P_u = initial pressure of the lowermost USDW,
- ρ_i = fluid density of the injection zone,
- ρ_u = fluid density of the lowermost USDW,
- g = acceleration due to gravity,
- z_u = elevation of the lowermost USDW, and
- z_i = elevation of the injection zone.

Using this method, ADM calculated a $P_{i,f}$ value equal to 171 psi (1.18 MPa).

As an alternative approach for estimating a critical pressure in the injection zone, in December 2013, ADM applied a method developed and published by Nicot et al. (2008):

$$\frac{\Delta P}{g} = \frac{\xi}{2} (z_u - z_i)^2$$

This method estimates a pressure differential that would displace fluid initially present in a hypothetical borehole into the lowermost USDW and is based on two assumptions: (1) hydrostatic conditions; and (2) initially linearly varying densities in the borehole and constant density once the injection zone fluid is lifted to the top of the borehole.

ADM used the Nicot method to calculate the pressure differential based on an injection depth of -6,628 ft KB and a lowermost USDW depth of approximately -3,450 ft KB. The results yield an estimate of approximately 62.2 psi (0.43 MPa).

Model Calibration

The site model has been calibrated using operational data obtained from the IBDP project through January 2013. The IBDP injection rate was input into the simulation to calculate the bottom hole pressures and pressures at five different zones at the verification well. The simulated pressures compared well to the observed pressures. Reservoir permeability and skin were the main parameters impacting the injection pressure calibration and were used as fitting parameters. Actual spinner data was used to set the fractions of the total injection between the two sets of perforations in the injection well. These data along with the simulation allowed for fine tuning of the well bore skin values at respective perforations together with the permeability to match injection bottom hole pressure (Figure 3). Once the injection bottom hole pressure was calibrated, simulated pressures at five different zones at the verification well were fine-tuned calibrating the k_v/k_h ratio of the tight sections and compressibility of the reservoir rock (Figure 4).

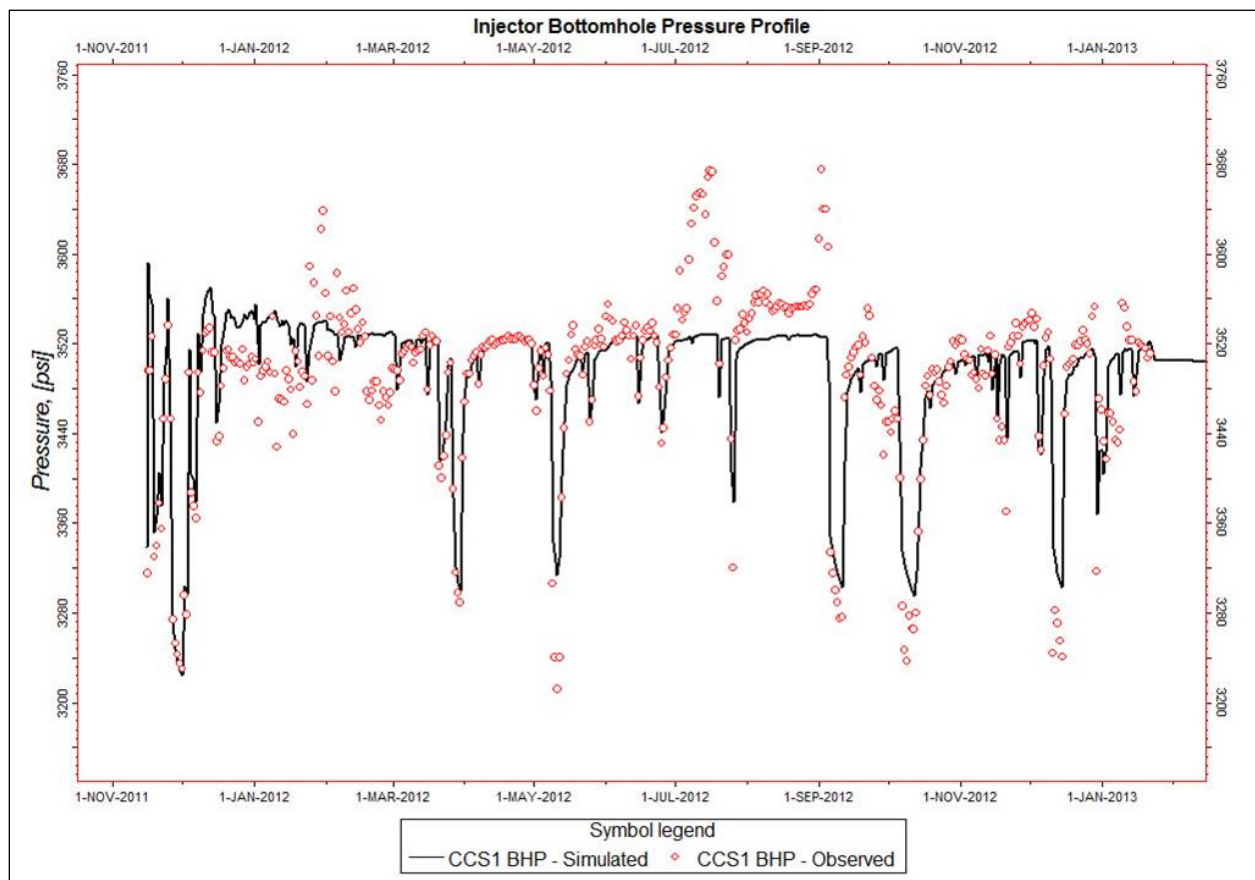

Figure 3. History Matched Injection Bottom Hole Pressure (BHP) for CCS#1, submitted February 2014.

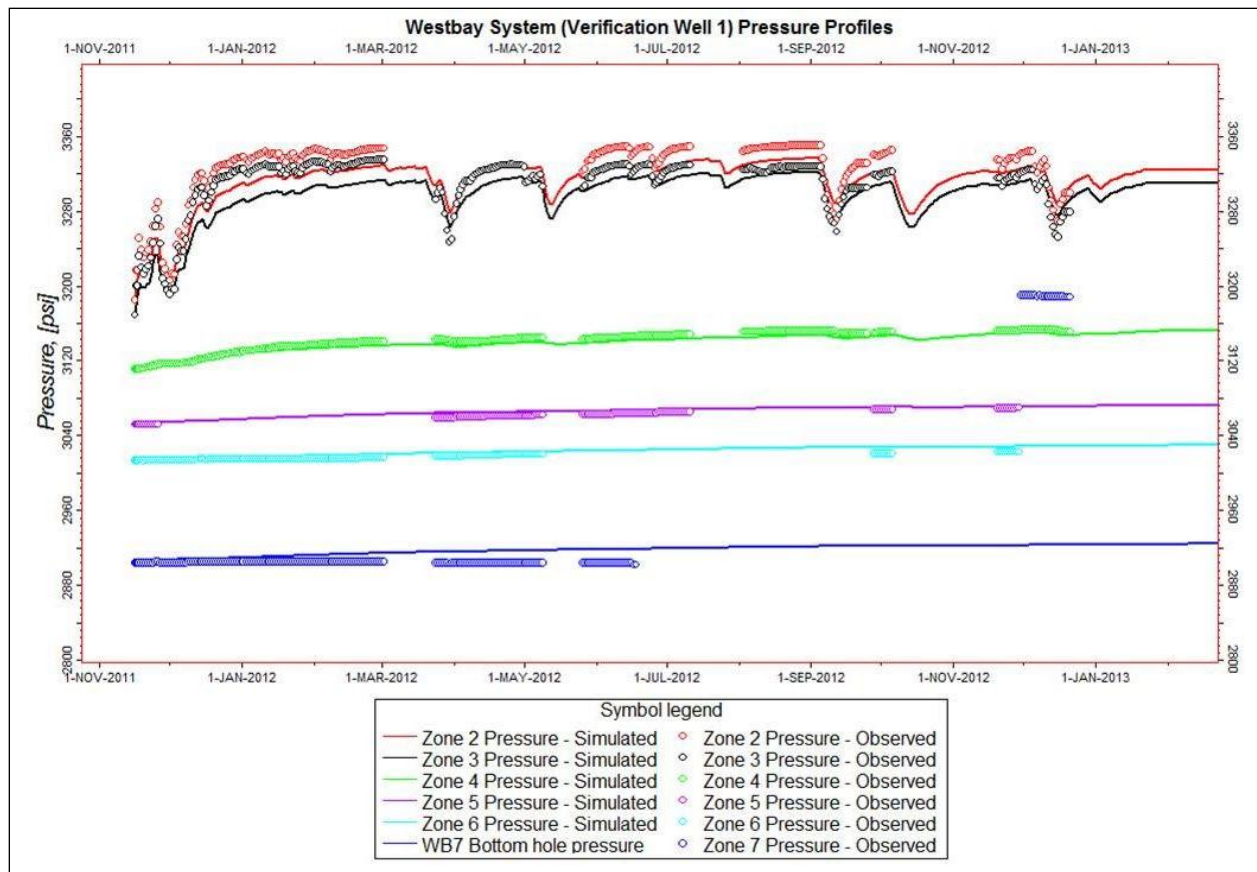

Figure 4. History Matched Pressures at VW#1 for CCS#1, submitted February 2014.

RST well logs helped estimate the location, saturation, and thickness of the CO₂ column around the injection and verification wells. This information helped fine tune the end points of relative permeability curves which dominate the CO₂ and brine flow in the reservoir. Figure 5 and Figure 6 show the relative permeability curves and the constitutive relationships for the reservoir rock types used to characterize the lower and middle Mt. Simon storage units. Figure 5 shows the relative permeability with respect to brine saturation (S_w), for the CO₂-brine system during drainage and imbibition. Where: brine drainage (k_{rw}) represents the relative permeability of brine during drainage, brine imbibition (k_{rw}) represents the relative permeability of brine during imbibition, CO₂ drainage (k_{rg}) represents the relative permeability of CO₂ during drainage, and CO₂ imbibition (k_{rg}) represents the relative permeability of CO₂ during imbibition. Please note that drainage is defined as CO₂ replacing brine in the pores and imbibition is defined as brine replacing CO₂ in the pores.

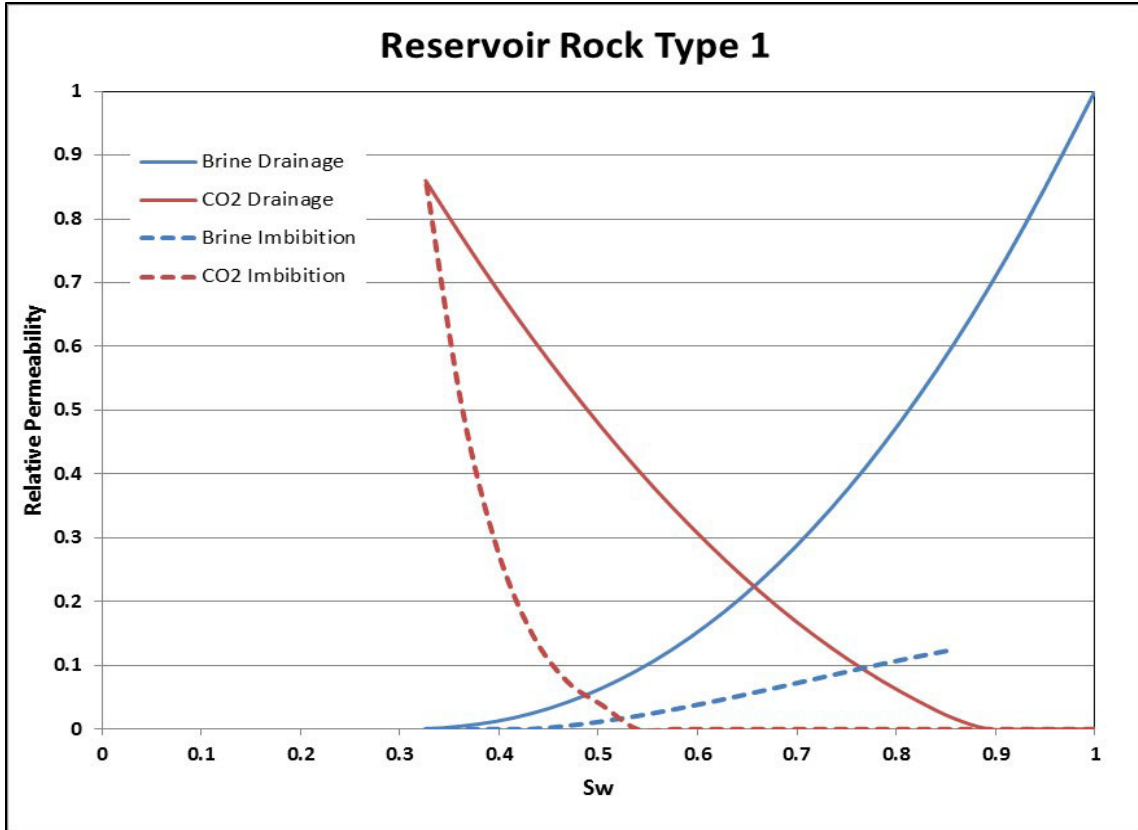

Figure 5. Calibrated Relative Permeability Curves – Type 1 LL Mt. Simon, submitted March 2016.

| Rock Type | | Rel. Perm | | Capillary Pressure (P _c) |
|-----------|-------------------------|---|--|--|
| | | CO ₂ | Brine | |
| 1 | Drainage | From lab data See Figure 5 | From lab data See Figure 5 | van Genuchten model (data from Battelle, 2011) $S_e = (S_w - S_{w,ir}) / (1 - S_{w,ir})$ $P_c = \alpha^{-1} [(S_e^{-1/m} - 1)]^{1/n}$ $\alpha = 0.5$ $m = 0.8$ $n = 1 / (1 - m)$ |
| | Imbibition (hysteresis) | From lab data See Figure 5 | From lab data See Figure 5 | No Hysteresis |
| 2 | Drainage | Brooks-Corey (see Krevor et al. 2012) $S_e = (S_w - S_{w,ir}) / (1 - S_{w,ir})$ $K_{rg} = k_{rg}(S_{w,ir}) (1 - S_e)^2 (1 - S_e^{N_{CO_2}})$ $N_{CO_2} = 4$ | Brooks-Corey (see Krevor et al. 2012) $S_e = (S_w - S_{w,ir}) / (1 - S_{w,ir})$ $K_{rw} = S_e^{N_w}$ $N_w = 9$ | Brooks-Corey (see Krevor et al. 2012) $P_c = P_e * S_e^{-1/\lambda}$ $P_e = 0.667$ $\lambda = 0.55$ |
| | Imbibition (hysteresis) | Land's model $K_{rg} = k_{rg}(S_{w,ir}) (1 - S_e)^2 (1 - S_e^{N_{CO_2}})$ where $S_e = (S_{w,bt} - S_{w,ir}) / (1 - S_{w,ir})$ $S_{w,bt} = 1 - S_{CO_2,bt}$ $S_{CO_2,bt} = S_{CO_2,c}^* (1 - S_{w,ir})$ $S_{CO_2,c}^* = 0.5 \{ (S_{CO_2,c}^* - S_{CO_2,r}^*) + [(S_{CO_2,c}^* - S_{CO_2,r}^*)^2 + 4/C (S_{CO_2,c}^* - S_{CO_2,r}^*)]^{0.5} \}$ $S_{CO_2,c}^* = S_{CO_2} / (1 - S_{w,ir})$ $S_{CO_2,r}^* = S_{CO_2,i} / (1 + C S_{CO_2,i}^*)$ $S_{CO_2,i}^* = S_{CO_2,i} / (1 - S_{w,ir})$ $C = 2.1$ $N_{CO_2} = 4$ | No Hysteresis | Land's model $P_c = P_e * S_e^{-1/\lambda}$ where $P_e = 0.667$ $\lambda = 0.55$ $S_e = (S_{w,bt} - S_{w,ir}) / (1 - S_{w,ir})$ $S_{w,bt} = 1 - S_{CO_2,bt}$ $S_{CO_2,bt} = S_{CO_2,c}^* (1 - S_{w,ir})$ $S_{CO_2,c}^* = 0.5 \{ (S_{CO_2,c}^* - S_{CO_2,r}^*) + [(S_{CO_2,c}^* - S_{CO_2,r}^*)^2 + 4/C (S_{CO_2,c}^* - S_{CO_2,r}^*)]^{0.5} \}$ $S_{CO_2,c}^* = S_{CO_2} / (1 - S_{w,ir})$ $S_{CO_2,r}^* = S_{CO_2,i} / (1 + C S_{CO_2,i}^*)$ $S_{CO_2,i}^* = S_{CO_2,i} / (1 - S_{w,ir})$ $C = 2.1$ |
| 3 | Drainage | van Genuchten model $S_e = (S_w - S_{w,ir}) / (1 - S_{w,ir})$ $K_{rg} = k_{rg}(S_{w,ir}) (1 - S_e)^{1/2} (1 - S_e^{1/m})^{2m}$ $m = 0.41$ | van Genuchten model $S_e = (S_w - S_{w,ir}) / (1 - S_{w,ir})$ $K_{rw} = S_e^{1/2} [1 - (1 - S_e^{1/m})^m]^2$ $m = 0.41$ | van Genuchten model (entry pressure obtained from Lahann et al., 2014) $P_c = \alpha^{-1} [(S_e^{-1/m} - 1)]^{1/n}$ $n = 1 / (1 - m)$ $\alpha = 6.495E-2$ $m = 0.41$ |
| | Imbibition (hysteresis) | No Hysteresis | No Hysteresis | No Hysteresis |

Figure 6. Constitutive relationships for rock types used in AoR modeling, submitted March 2016.

Using the calibrated model, a predictive simulation was run to evaluate plume development and pressure perturbation during the course of injection.

Computational Modeling Results

The map below presents the AoR based on the modeling results (the maximum extent of the plume and pressure front), along with wells identified within the AoR.

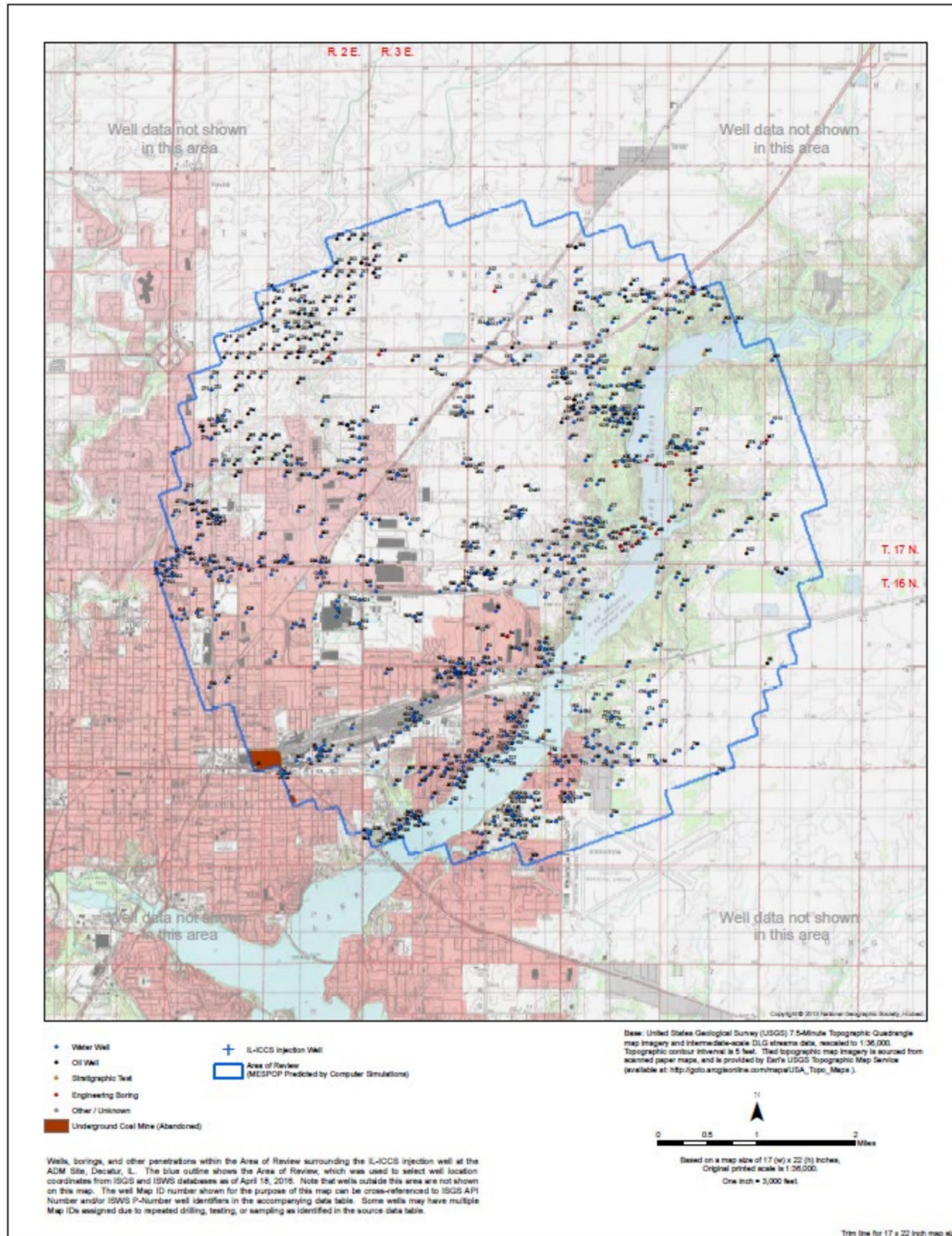

Figure 7. Map of the AoR as delineated by the reservoir model simulation.

The surface area of the AoR is 34.17 square miles. The predicted evolution of the plume and pressure front relative to monitoring locations is shown in the Testing and Monitoring Plan (Attachment C to this permit) and the Post-Injection Site Care (PISC) and Site Closure Plan (Attachment E to this permit).

Corrective Action Plan and Schedule

Based on information from the Illinois State Geological Survey (ISGS) and the Illinois State Water Survey (ISWS) gathered in April 2016, ADM identified a total of 1,065 wells within the AoR. According to Illinois Department of Natural Resources (IDNR) drilling records (and confirmed by ISGS), no additional oil and gas wells were drilled in Macon County between April and September 2016. Except for the wells associated with the IBDP and IL-ICCS projects (as described below), no wells were identified that penetrate the confining zone within the AoR.

Tabulation of Wells within the AoR

Wells within the AoR

The only existing wells within the AoR which currently penetrate the caprock (Eau Claire Formation) are wells associated with the IBDP and IL-ICCS projects:

- The IBDP injection well, CCS#1 (which is currently permitted as a Class VI well in its post-injection phase and will be used as a monitoring well during the IL-ICCS project).
- The IBDP verification well, VW#1 (which will continue to be used as a monitoring well during the IL-ICCS project).
- The IL-ICCS injection well, CCS#2.
- The IL-ICCS verification well, VW#2.

The latest estimate shows that a total of 1,065 wells are located within the AoR. Water wells (725 of 1,065 wells) are the most common well type. The domestic water wells generally have depths of less than 60 m (200 ft). Other wells include stratigraphic test holes, non-domestic water wells, and oil and gas wells. As part of the original permit application, all wells within the 4 townships-area of the injection well site were also identified (total of 3,761 wells at that time). Information regarding these wells was provided as a supplement to the permit application (available in an electronic format).

Ten oil and gas wells are located within approximately 2.4 km (1.5 miles) of the injection well location. The closest well is located in the northeast quarter of Section 5, T16N, R3E. This well (API number 121150061800) was drilled as a gas well in 1933 and was -27 m (-88 ft KB) deep. There is no record of this well being plugged. This well was likely collecting naturally occurring methane from the Quaternary sediments. The other 9 wells are located in Section 5, T16N, R3E or Section 28 and Section 29, T17N, R3E. The deepest of these oil wells is API number 121152369400, located in the northeast quarter of Section 34. This well was drilled into the Ordovician and was -905 m KB (-2,970 ft KB) deep.

Wells Penetrating the Confining Zone

With the exception of the injection and verification wells previously detailed, there are no known wells within the area of review that penetrate deeper than -905 m KB (-2,970 ft KB). The depth to the top of the injection zone (Mt. Simon Sandstone) is -1,690 m KB (-5,545 ft KB). Therefore, there are only four known wells that penetrate into the uppermost injection zone: the IBDP wells CCS#1 and VW#1, and the IL-ICCS wells CCS#2 and VW#2.

If any of these wells are taken out of service during the life of the project, ADM will provide information to EPA to confirm that they have been properly plugged to ensure USDW protection pursuant to requirements at 40 CFR Part 146. If any additional wells that penetrate the confining zone are identified (e.g., if the AoR is re-delineated to cover a larger area as the result of an AoR reevaluation), ADM will complete corrective action as needed pursuant to 40 CFR 146.84(d).

Wells Requiring Corrective Action

Based on information about the wells in existence at the time of permit issuance, no corrective action is required prior to initiation of injection.

Plan for Site Access

This is not applicable because no corrective action is required at this time.

Justification of Phased Corrective Action

This is not applicable because no corrective action is required at this time.

Area of Review Reevaluation Plan and Schedule

ADM will take the following steps to evaluate project data and, if necessary, reevaluate the AoR. AoR reevaluations will be performed during the injection and post-injection phases. ADM will:

- Review available monitoring data and compare it to the model predictions. ADM will analyze monitoring and operational data from the injection well (CCS#2), the monitoring and geophysical wells, other surrounding wells, and other sources to assess whether the predicted CO₂ plume migration is consistent with actual data. Monitoring activities to be conducted are described in the Testing and Monitoring Plan (Attachment C to this permit) and the PISC and Closure Plan (Attachment E to this permit). Specific steps of this review include:
 - Reviewing available data on the position of the CO₂ plume and pressure front (including pressure and temperature monitoring data and RST saturation and seismic survey data). Specific activities will include:
 - Correlating data from time-lapse RST logs, time-lapse VSP surveys, and other seismic methods (e.g., 3D surveys) to locate and track the movement of the CO₂ plume. A good correlation between the data sets will provide strong evidence in validating the model's ability to represent the storage

system. Also, 2D and 3D seismic surveys will be employed to determine the plume location as described in the Testing and Monitoring Plan and/or the PISC and Site Closure Plan (as applicable).

- Reviewing downhole reservoir pressure data collected from various locations and intervals using a combination of surface and downhole pressure gauges.
 - Reviewing ground water chemistry monitoring data taken in the shallow (i.e., in Quaternary and/or Pennsylvanian strata) monitoring wells, the St. Peter, and the Ironton-Galesville to verifying that there is no evidence of excursion of carbon dioxide or brines that represent an endangerment to any USDWs.
 - Reviewing operating data, e.g., on injection rates and pressures, and verifying that it is consistent with the inputs used in the most recent modeling effort.
 - Reviewing any geologic data acquired since the last modeling effort, e.g., additional site characterization performed, updates of petrophysical properties from core analysis, etc. Identifying whether any new data materially differ from modeling inputs/assumptions.
- Compare the results of computational modeling used for AoR delineation to monitoring data collected. Monitoring data will be used to show that the computational model accurately represents the storage site and can be used as a proxy to determine the plume's properties and size. ADM will demonstrate this degree of accuracy by comparing monitoring data against the model's predicted properties (i.e., plume location, rate of movement, and pressure decay). Statistical methods will be employed to correlate the data and confirm the model's ability to accurately represent the storage site.
 - If the information reviewed is consistent with, or is unchanged from, the most recent modeling assumptions or confirms modeled predictions about the maximum extent of plume and pressure front movement, ADM will prepare a report demonstrating that, based on the monitoring and operating data, no reevaluation of the AoR is needed. The report will include the data and results demonstrating that no changes are necessary.
 - If material changes have occurred (e.g., in the behavior of the plume and pressure front, operations, or site conditions) such that the actual plume or pressure front may extend beyond the modeled plume and pressure front, ADM will re-delineate the AoR. The following steps will be taken:
 - Revising the site conceptual model based on new site characterization, operational, or monitoring data.
 - Calibrating the model in order to minimize the differences between monitoring data and model simulations.
 - Performing the AoR delineation as described the Computational Modeling Section of this AoR and Corrective Action Plan.
 - Review wells in any newly identified areas of the AoR and apply corrective action to deficient wells. Specific steps include:

- Identifying any new wells within the AoR that penetrate the confining zone and provide a description of each well's type, construction, date drilled, location, depth, record of plugging and/or completion.
- Determining which abandoned wells in the newly delineated AoR have been plugged in a manner that prevents the movement of carbon dioxide or other fluids that may endanger USDWs.
- Performing corrective action on all deficient wells in the AoR using methods designed to prevent the movement of fluid into or between USDWs, including the use of materials compatible with carbon dioxide.
- Prepare a report documenting the AoR reevaluation process, data evaluated, any corrective actions determined to be necessary, and the status of corrective action or a schedule for any corrective actions to be performed. The report will be submitted to EPA within one year of the reevaluation. The report will include maps that highlight similarities and differences in comparison with previous AoR delineations.
- Update the AoR and Corrective Action Plan to reflect the revised AoR, along with other related project plans, as needed.

AoR Reevaluation Cycle

ADM will reevaluate the above described AoR every five years during the injection and post-injection phases.

In addition, monitoring and operational data will be reviewed periodically (likely annually) by ADM during the injection and post-injection phases. Given inconclusive results in the CCS#2 step-rate test, ADM will modify their monitoring and reporting schedule to collect and review data more regularly during the first six months of the injection phase. Specifically, pressure and seismic results will be reviewed on a monthly basis to identify any deviations from expected conditions (see Attachment A of this permit for more detail). The reservoir flow model will be history matched against the observed parameters measured at the monitoring wells. Pressure will be monitored as described in the Testing and Monitoring Plan. The time lapse pressure monitoring data will be compared to the model predicted time lapse pressure profiles. ADM will provide a brief report of this review to the UIC Program Director and discuss the findings.

If data suggest that a significant change in the size or shape of the actual CO₂ plume as compared to the predicted CO₂ plume and/or pressure front is occurring or there are deviations from modeled predictions such that the actual plume or pressure front may extend vertically or horizontally beyond the modeled plume and pressure front, ADM will initiate an AoR reevaluation prior to the next scheduled reevaluation. Such deviations may be evidenced by the results of direct or indirect monitoring activities including MIT failures or loss of MI; observed pressure and saturation profiles; changes in the physical or chemical characteristics of the CO₂; any detection of CO₂ above the confining zone (e.g., based on hydrochemical/physical parameters); microseismic data indicating slippage in or near the confining zone or microseismic data within the injection zone that indicates slippage and propagation into the confining zone; or arrival of the CO₂ plume and/or pressure front at certain monitoring locations that diverges from expectations, as described below.

Triggers for AoR Reevaluations Prior to the Next Scheduled Reevaluation

Unscheduled reevaluation of the AoR will be based on quantitative changes of the monitoring parameters in the deep monitoring wells, including unexpected changes in the following parameters: pressure, temperature, neutron saturation, and the deep ground water (> 3,000 ft below KB) constituent concentrations indicating that the actual plume or pressure front may extend beyond the modeled plume and pressure front. These changes include:

- ***Pressure:*** Changes in pressure that are unexpected and outside three (3) standard deviations from the average will trigger a new evaluation of the AoR.
- ***Temperature:*** Changes in temperature that are unexpected and outside three (3) standard deviations from the average will trigger a new evaluation of the AoR.
- ***RST Saturation:*** Increases in CO₂ saturation that indicate the movement of CO₂ into or above the confining zone will trigger a new evaluation of the AoR unless the changes are found to be related to the well integrity. (Any well integrity issues will be investigated and addressed.)
- ***Deep ground water constituent concentrations:*** Unexpected changes in fluid constituent concentrations that indicate movement of CO₂ or brines into or above the confining zone will trigger a new evaluation of the AoR unless the changes are found to be related to the well integrity. (Any well integrity issues will be investigated and addressed.)
- ***Exceeding Fracture Pressure Conditions:*** Pressure in any of the injection or monitoring wells exceeding 90 percent of the geologic formation fracture pressure at the point of measurement. This would be a violation of the permit conditions. The Testing and Monitoring Plan (Attachment C to this permit) and the operating procedures in Attachment A to this permit provides discussion of pressure monitoring and specific procedures that will be completed during the injection start-up period.
- ***Exceeding Established Baseline Hydrochemical/Physical Parameter Patterns:*** A statistically significant difference between observed and baseline hydrochemical/physical parameter patterns (e.g., fluid conductivity, pressure, temperature) immediately above the confining zone. The Testing and Monitoring Plan (Attachment C to this permit) provides extended information regarding how pressure, temperature, and fluid conductivity will be monitored.
- ***Compromise in Injection Well Mechanical Integrity:*** A significant change in pressure within the protective annular pressurization system surrounding each injection well that indicates a loss of mechanical integrity at an injection well.
- ***Seismic Monitoring Identification of Subsurface Structural Features:*** Seismic monitoring data that indicates the presence of a fault or fracture in or near the confining zone or a fault or fracture within the injection zone that indicates propagation into the confining zone. The Testing and Monitoring Plan provides extended information about the microseismic monitoring network.

An unscheduled AoR reevaluation may also be needed if it is likely that the actual plume or pressure front may extend beyond the modeled plume and pressure front because any of the following has occurred:

- Seismic event greater than M3.5 within 8 miles of the injection well;
- If there is an exceedance of any Class VI operating permit condition (e.g., exceeding the permitted volumes of carbon dioxide injected); or
- If new site characterization data changes the computational model to such an extent that the predicted plume or pressure front extends vertically or horizontally beyond the predicted AoR.

ADM will discuss any such events with the UIC Program Director to determine if an AoR reevaluation is required.

If an unscheduled reevaluation is triggered, ADM will perform the steps described at the beginning of this section of this Plan.

ATTACHMENT C: TESTING AND MONITORING PLAN

Facility Information

Facility name: Archer Daniels Midland, CCS#2 Well
IL-115-6A-0001
4666 Faries Parkway, Decatur, IL

Well location: Decatur, Macon County, IL;
39°53'09.32835", -88°53'16.68306"

This Testing and Monitoring Plan describes how ADM will monitor the CCS#2 site pursuant to 40 CFR 146.90. In addition to demonstrating that the well is operating as planned, the carbon dioxide plume and pressure front are moving as predicted, and that there is no endangerment to USDWs, the monitoring data will be used to validate and adjust the geological models used to predict the distribution of the CO₂ within the storage zone to support AoR reevaluations and a non-endangerment demonstration.

Quality Assurance Procedures

A quality assurance and surveillance plan (QASP) for all testing and monitoring activities pursuant to 40 CFR 146.90(k) is provided in the Appendix to this Testing and Monitoring Plan.

Carbon Dioxide Stream Analysis

ADM will analyze the CO₂ stream during the operation period to yield data representative of its chemical and physical characteristics and to meet the requirements of 40 CFR 146.90(a). Sampling will take place quarterly, by the following dates each year: 3 months after the date of authorization of injection, 6 months after the date of authorization of injection, 9 months after the date of authorization of injection, and 12 months after the date of authorization of injection.

ADM will sample and analyze the CO₂ stream as described in Section 6A.1 of the permit application and presented below.

Analytical Parameters

ADM will analyze the CO₂ for the constituents identified in Table 1 using the methods listed. Sampling will take place quarterly, by the following dates each year: 3 months after the date of authorization of injection, 6 months after the date of authorization of injection, 9 months after the date of authorization of injection, and 12 months after the date of authorization of injection.

Table 1. Summary of analytical parameters for CO₂ gas stream.

| Parameters | Analytical Methods ⁽¹⁾ |
|------------|-----------------------------------|
| Oxygen | ISBT 4.0 (GC/DID) GC/TCD |

| Parameters | Analytical Methods ⁽¹⁾ |
|------------------------|--|
| Nitrogen | ISBT 4.0 GC/DID GC/TCD |
| Carbon Monoxide | ISBT 5.0 Colorimetric ISBT 4.0 (GC/DID) |
| Oxides of Nitrogen | ISBT 7.0 Colorimetric |
| Total Hydrocarbons | ISBT 10.0 THA (FID) |
| Methane | ISBT 10.1 GC/FID) |
| Acetaldehyde | ISBT 11.0 (GC/FID) |
| Sulfur Dioxide | ISBT 14.0 (GC/SCD) |
| Hydrogen Sulfide | ISBT 14.0 (GC/SCD) |
| Ethanol | ISBT 11.0 (GC/FID) |
| CO ₂ Purity | ISBT 2.0 Caustic absorption Zahm-Nagel ALI method SAM 4.1 subtraction method (GC/DID) GC/TCD |

Note 1: An equivalent method may be employed with the prior approval of the UIC Program Director.

Sampling Methods

CO₂ stream sampling will occur in the compressor building after the last stage of compression. A sampling station will be installed with the ability to purge and collect samples into a container that will be sealed and sent to the authorized laboratory.

All sample containers will be labeled with durable labels and indelible markings. A unique sample identification number and sampling date will be recorded on the sample containers.

Laboratory to be Used/Chain of Custody Procedures

Samples will be analyzed by a third party laboratory using standardized procedures for gas chromatography, mass spectrometry, detector tubes, and photo ionization. The sample chain-of-custody procedures described in Section B.3 of the QASP will be employed.

Continuous Recording of Injection Pressure, Rate, and Volume; Annulus Pressure

ADM will install and use continuous recording devices to monitor injection pressure, rate, and volume, the pressure on the annulus between the tubing and the long string casing, and the annulus fluid volume added.

ADM will perform the activities identified in Table 2 to verify internal mechanical integrity of the injection well and monitor injection pressure, rate, volume and annular pressure as required at 40 CFR 146.88, 146.89, and 146.90(b). All monitoring will be continuous for the duration of the operation period, and at the locations shown in the table. The injection well will have

pressure/temperature gauges at the surface and in the tubing at the packer. In addition there will be distributed temperature sensing (DTS) fibers in the injection well.

Table 2. Sampling Locations for Continuous Monitoring.

| Test Description | Location |
|-------------------------------|------------------------------------|
| Annular Pressure Monitoring | Surface |
| Injection Pressure Monitoring | Surface |
| Injection Pressure Monitoring | Reservoir - Proximate to packer |
| Injection Rate Monitoring | Surface |
| Injection Volume Monitoring | Surface |
| Temperature Monitoring | Surface |
| Temperature Monitoring | Reservoir - Proximate to packer |
| Temperature Monitoring | Along wellbore to packer using DTS |

Above-ground pressure and temperature instruments shall be calibrated over the full operational range at least annually using ANSI or other recognized standards. In lieu of removing the injection tubing, downhole gauges will demonstrate accuracy by using a second pressure gauge, with current certified calibration, that will be lowered into the well to the same depth as the permanent downhole gauge. Pressure transducers shall have a drift stability of less than 1 psi over the operational period of the instrument and an accuracy of ± 5 psi. Sampling rates will be at least once per 5 seconds. Temperature sensors will be accurate to within one degree Celsius. DTS sampling rate will be once per 10 seconds.

Flow will be monitored with a Coriolis mass flowmeter at the compression facility. The flowmeter will be calibrated using accepted standards and be accurate to within ± 0.1 percent. The flowmeter will be calibrated for the entire expected range of flow rates.

Injection Rate and Pressure Monitoring

ADM will monitor injection operations using the distributive process control system, as described in Section 6A.2.2.3 of the CCS#2 permit application and presented below.

The Surface Facility Equipment & Control System will limit maximum flow to 3,300 MT/day and/or limit the well head pressure to 2,284 psig, which corresponds to the regulatory requirement to not exceed 90% of the injection zone’s fracture pressure. All injection operations will be continuously monitored and controlled by the ADM operations staff using the distributive process control system. This system will continuously monitor, control, record, and will alarm and shutdown if specified control parameters exceed their normal operating range.

More specifically, all critical system parameters, e.g., pressure, temperature, and flow rate will have continuous electronic monitoring with signals transmitted back to a master control system. ADM supervisors and operators will have the capability to monitor the status of the entire system from distributive control centers but mainly from two locations: the phase 1 compression control

room (near the CO₂ collection and blower facility), and the phase 2 main compression control room.

Calculation of Injection Volumes

Flow rate is measured on a mass basis (kg/hr). The downhole pressure and temperature data will be used to perform the injectate density calculation.

The volume of carbon dioxide injected will be calculated from the mass flow rate obtained from the mass flow meter installed on the injection line. The mass flow rate will be divided by density and multiplied by injection time to determine the volume injected.

Density will be calculated using the correlation developed by Ouyang (2011). The correlation uses the temperature and pressure data collected to determine the carbon dioxide density. The density correlation is given by:

$$\rho = A_0 + A_1 * P + A_2 * P^2 + A_3 * P^3 + A_4 * P^4$$

Where ρ is the density, P is the pressure in psi, and A are coefficients determined by the equations:

$$A_i = b_{i0} + b_{i1} * T + b_{i2} * T^2 + b_{i3} * T^3 + b_{i4} * T^4$$

T is the temperature in degrees Celsius and the b coefficients are presented in Table 3 and Table 4 below.¹

Table 3. Injection volume calculation b coefficients, pressure < 3000 psi.

| | b_{i0} | b_{i1} | b_{i2} | b_{i3} | b_{i4} |
|-----|-----------------------|-----------------------|-----------------------|-----------------------|-----------------------|
| i=0 | -2.148322085348E+05 | 1.168116599408E+04 | -2.302236659392E+02 | 1.967428940167E+00 | -6.184842764145E-03 |
| i=1 | 4.757146002428E+02 | -2.619250287624E+01 | 5.215134206837E-01 | -4.494511089838E-03 | 1.423058795982E-05 |
| i=2 | -3.713900186613E-01 | 2.072488876536E-02 | -4.169082831078E-04 | 3.622975674137E-06 | -1.155050860329E-08 |
| i=3 | 1.228907393482E-04 | -6.930063746226E-06 | 1.406317206628E-07 | -1.230995287169E-09 | 3.948417428040E-12 |
| i=4 | -1.466408011784E-08 | 8.338008651366E-10 | -1.704242447194E-11 | 1.500878861807E-13 | -4.838826574173E-16 |

Table 4. Injection volume calculation b coefficients, pressure > 3000 psi.

| | b_{i0} | b_{i1} | b_{i2} | b_{i3} | b_{i4} |
|-----|-----------------------|-----------------------|-----------------------|-----------------------|-----------------------|
| i=0 | 6.897382693936E+02 | 2.730479206931E+00 | -2.254102364542E-02 | -4.651196146917E-03 | 3.439702234956E-05 |
| i=1 | 2.213692462613E-01 | -6.547268255814E-03 | 5.982258882656E-05 | 2.274997412526E-06 | -1.888361337660E-08 |
| i=2 | -5.118724890479E-05 | 2.019697017603E-06 | -2.311332097185E-08 | -4.079557404679E-10 | 3.893599641874E-12 |
| i=3 | 5.517971126745E-09 | -2.415814703211E-10 | 3.121603486524E-12 | 3.171271084870E-14 | -3.560785550401E-16 |
| i=4 | -2.184152941323E-13 | 1.010703706059E-14 | -1.406620681883E-16 | -8.957731136447E-19 | 1.215810469539E-20 |

¹ Ouyang 2011, “New Correlations for Predicting the Density and Viscosity of Supercritical Carbon Dioxide Under Conditions Expected in Carbon Capture and Sequestration Operations,” The Open Petroleum Engineering Journal, 2011, 4, 13-21.

The final volume basis will be calculated as follows:

$$\text{Volume basis (m}^3\text{/hr)} = \text{Mass basis (kg/hr)} / \text{density (kg/m}^3\text{)}$$

Continuous Monitoring of Annular Pressure

ADM will use the procedures below to monitor annular pressure, as described in Section 6A.3.1 of the CCS #2 permit application.

The following procedures will be used to limit the potential for any unpermitted fluid movement into or out of the annulus:

1. The annulus between the tubing and the long string of casing will be filled with brine. The brine will have a specific gravity of 1.26 and a density of 10.5 lbs/gal. The hydrostatic gradient is 0.546 psi/ft. The brine will contain a corrosion inhibitor.
2. The surface annulus pressure will be kept at a minimum of 400 pounds per square inch (psi) during injection.
3. During periods of well shut down, the surface annulus pressure will be kept at a minimum pressure to maintain a pressure differential of at least 100 psi between the annular fluid directly above (higher pressure) and below (lower pressure) the injection tubing packer set at 6,312 ft KB.
4. The pressure within the annular space, over the interval above the packer to the confining layer, will be greater than the pressure of the injection zone formation at all times.
5. The pressure in the annular space directly above the packer will be maintained at least 100 psi higher than the adjacent tubing pressure during injection.

Figure 1 shows the process instrument diagram for the injection well annulus protection system.

The annular monitoring system consists of a continuous annular pressure gauge, a pressurized annulus fluid reservoir (annulus head tank), pressure regulators, and tank fluid level indication. The annulus system will maintain annulus pressure by controlling the pressure on the annulus head tank using either compressed nitrogen or CO₂.

The annulus pressure will be maintained between approximately 425-525 psi and monitored by the ADM control system gauges. The annulus head tank pressure will be controlled by pressure regulators—one set of regulators to maintain pressure above 400 psi by adding compressed nitrogen or CO₂ and the other to relieve pressure above 525 psi by venting gas off the annulus head tank.

Any changes to the composition of annular fluid will be reported in the next report submitted to the permitting agency.

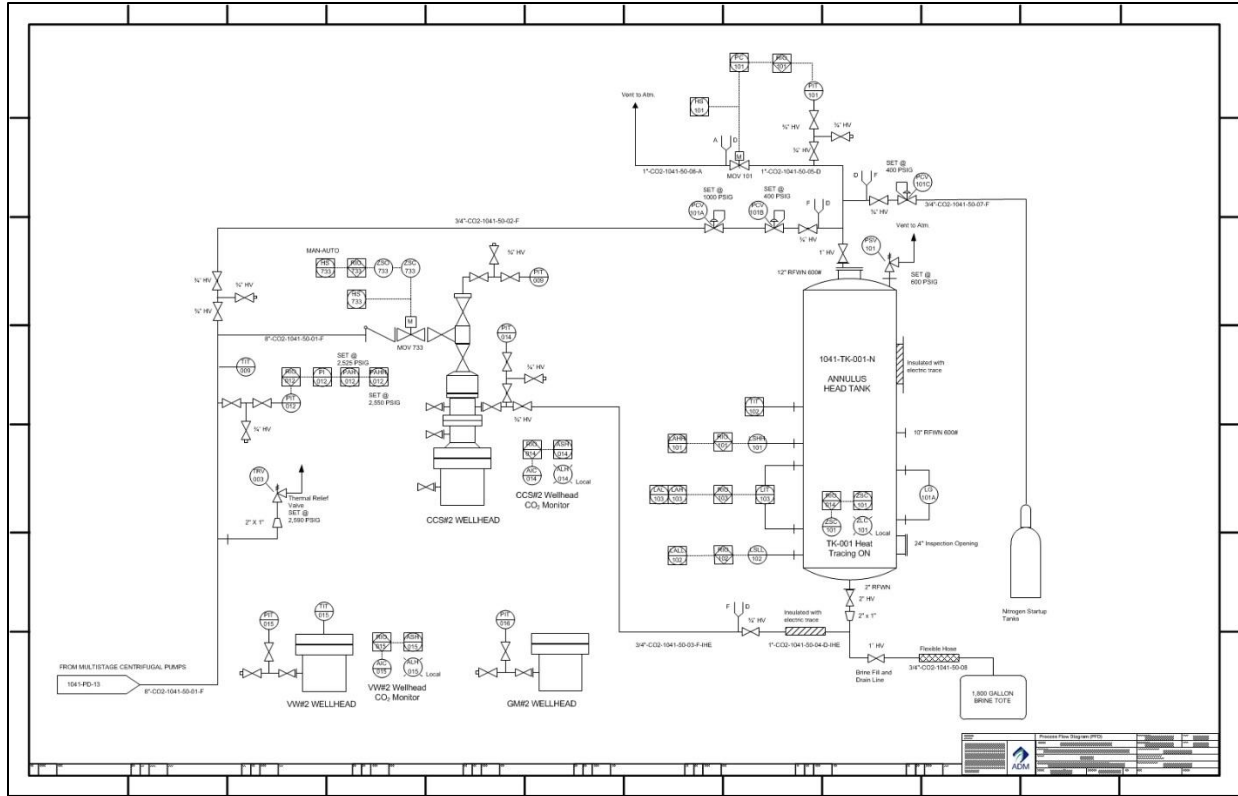

Figure 1. The annular monitoring system general layout.

If system communication is lost for greater than 30 minutes, project personnel will perform field monitoring of manual gauges every four hours or twice per shift for both wellhead surface pressure and annulus pressure, and record hard copies of the data until communication is restored.

Average annular pressure and annulus tank fluid level will be recorded daily. The volume of fluid added or removed from the system will be recorded.

Casing-Tubing Pressure Monitoring

ADM will monitor the casing-tubing pressure as described in Appendix G of the CCS#2 permit application and presented below.

During the injection timeframe of the project, the casing-tubing pressure will be monitored and recorded in real time. Surface pressure of the casing-tubing annulus is anticipated to be from 425 to 525 psi. As detailed in the Emergency and Remedial Response Plan (Attachment F to this permit), significant changes in the casing-tubing annular pressure attributed to well mechanical integrity will be investigated.

Collection and recording of monitoring data will occur at the frequencies described in Table 5.

Table 5. Sampling and Recording Frequencies for Continuous Monitoring.

| Well Condition | Minimum sampling frequency: once every ⁽¹⁾⁽⁴⁾ | Minimum recording frequency: once every ⁽²⁾⁽⁴⁾ |
|---|---|--|
| For continuous monitoring of the injection well when operating: | 5 seconds | 5 minutes ⁽³⁾ |
| For the injection well when shut-in: | 4 hours | 4 hours |

Note 1: Sampling frequency refers to how often the monitoring device obtains data from the well for a particular parameter. For example, a recording device might sample a pressure transducer monitoring injection pressure once every two seconds and save this value in memory.

Note 2: Recording frequency refers to how often the sampled information gets recorded to digital format (such as a computer hard drive). Following the same example above, the data from the injection pressure transducer might be recorded to a hard drive once every minute.

Note 3: This can be an average of the sampled readings over the previous 5-minute recording interval, or the maximum (or minimum, as appropriate) value identified over that recording interval.

Note 4: DTS sampling frequency is once every 10 seconds and recorded on an hourly basis.

Corrosion Monitoring

To meet the requirements of 40 CFR 146.90(c), ADM will monitor well materials during the operation period for loss of mass, thickness, cracking, pitting, and other signs of corrosion to ensure that the well components meet the minimum standards for material strength and performance.

This monitoring will occur quarterly, by the following dates each year: 3 months after the date of authorization of injection, 6 months after the date of authorization of injection, 9 months after the date of authorization of injection, and 12 months after the date of authorization of injection.

ADM will monitor corrosion using the corrosion coupon method and collect samples according to the description below and in Section 6A.3.5 of the CCS#2 permit application.

Sample Description

Samples of material used in the construction of the compression equipment, pipeline and injection well which come into contact with the CO₂ stream will be included in the corrosion monitoring program either by using actual material and/or conventional corrosion coupons. The samples consist of those items listed in Table 6 below. Each coupon will be weighed, measured, and photographed prior to initial exposure (see “Sample Handling and Monitoring” below).

Table 6. List of Equipment Coupon with Material of Construction.

| Equipment Coupon | Material of Construction |
|---------------------------------------|---------------------------------|
| Pipeline | CS A106B |
| Long String Casing (Surface - 4,800') | Carbon Steel |
| Long String Casing (4,800' – TD) | Chrome Alloy |
| Injection Tubing | Chrome alloy |
| Wellhead | Chrome alloy |

| Equipment Coupon | Material of Construction |
|------------------|--------------------------|
| Packers 1 | Chrome alloy |

Sample Exposure

Each sample will be attached to an individual holder (Figure 2a) and then inserted in a flow-through pipe arrangement (Figure 2b). The corrosion monitoring system will be located downstream of all process compression/dehydration/pumping equipment (i.e., at the beginning of the pipeline to the wellhead). To accomplish this, a parallel stream of high pressure CO₂ will be routed from the pipeline through the corrosion monitoring system and then back into a lower pressure point upstream in the compression system. This loop will operate any time injection is occurring. No other equipment will act on the CO₂ past this point; therefore this location will provide representative exposure of the samples to the CO₂ composition, temperature, and pressures that will be seen at the wellhead and injection tubing. The holders and location of the system will be included in the pipeline design and will allow for continuation of injection during sample removal.



Figure 2a. Coupon Holder.

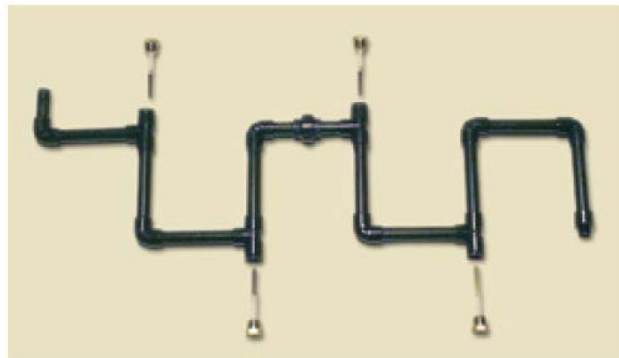

Figure 2b. Flow-through Pipe Arrangement.

Sample Handling and Monitoring

The coupons will be handled and assessed for corrosion using the American Society for Testing and Materials (ASTM) G1-03, Standard Practice for Preparing, Cleaning, and Evaluating Corrosion Test Specimens (ASTM 2011). The coupons will be photographed, visually inspected with a minimum of 10x power, dimensionally measured (to within 0.0001 inch), and weighed (to within 0.0001 gm).

Groundwater Quality Monitoring

ADM will monitor groundwater quality and geochemical changes above the confining zone during the operation period to meet the requirements of 40 CFR 146.90(d).

The groundwater monitoring plan focuses on the following zones:

- Quaternary and/or Pennsylvanian strata – the source of local drinking water.

- The St. Peter Formation – the lowermost USDW.
- The Ironton-Galesville Sandstone – the zone above the Eau Claire confining zone.

All of the monitoring locations are located on ADM property. Figure 3 shows the project area and the location of existing shallow groundwater monitoring wells and planned deep monitoring wells. Table 7 and Table 8 show the planned monitoring methods, locations, and frequencies for groundwater quality monitoring above the confining zone. ADM will also monitor in the Mt. Simon Sandstone (the injection zone). Monitoring in this layer will be to track the carbon dioxide plume and is described under “Carbon Dioxide Plume and Pressure Front Tracking” below.

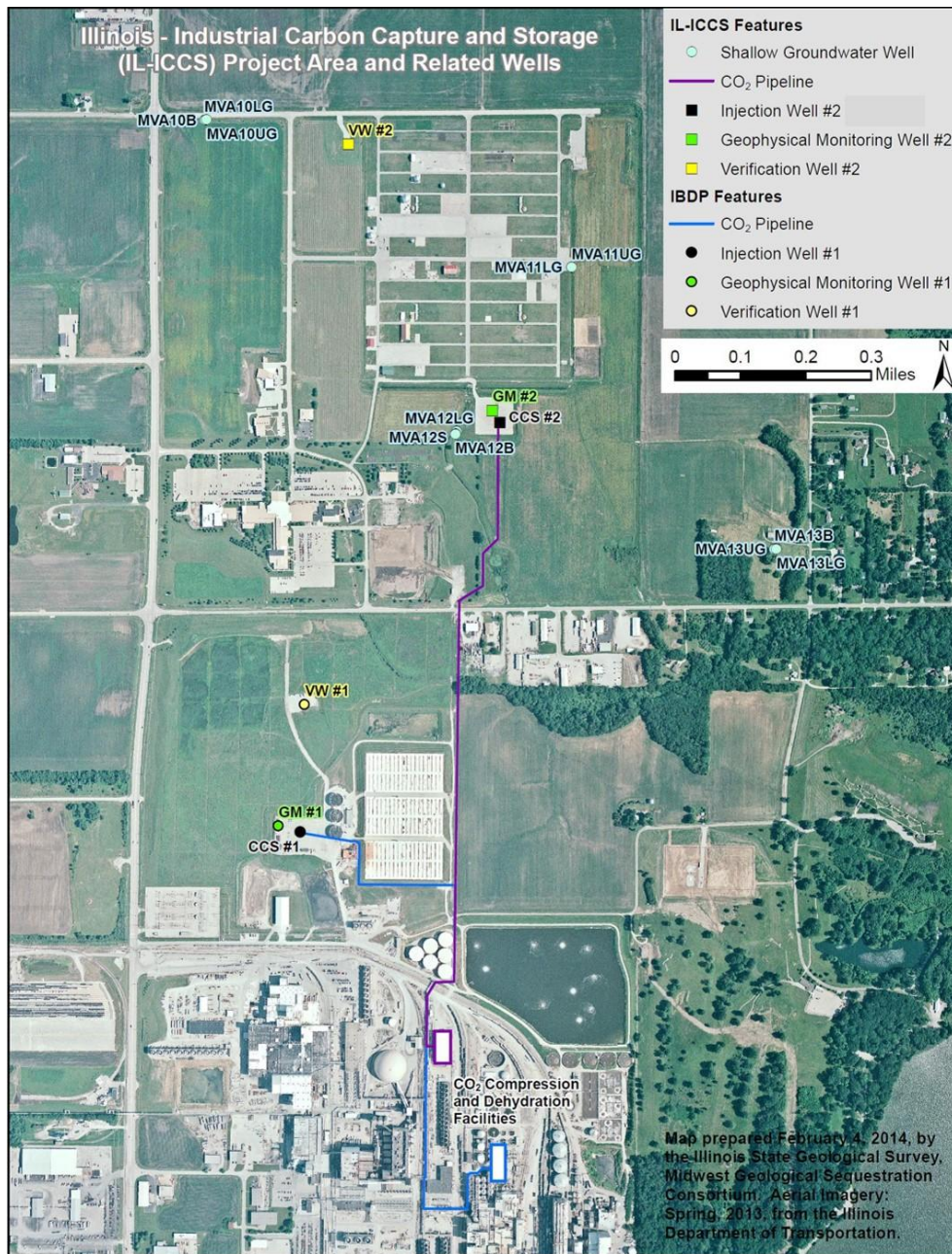

Figure 3. Location of shallow groundwater monitoring wells and deep monitoring wells.

Table 7. Direct Monitoring of Groundwater Quality and Geochemical Changes above the Confining Zone.

| Target Formation | Monitoring Activity | Monitoring Location(s) | Spatial Coverage | Frequency ⁽¹⁻⁵⁾ |
|--|---------------------------------|--|---|--|
| Quaternary and/or Pennsylvanian strata | Fluid sampling | Shallow monitoring wells: MVA10LG, MVA11LG, MVA12LG, MVA13LG | 4 point locations, 1 sampling interval each. Approx. depths: MVA10LG - 101 ft, MVA11LG - 107 ft, MVA12LG - 95 ft, MVA13LG - 80 ft | Baseline; Year 1-2: Quarterly; Year 3-5: Semi-Annual |
| | DTS | CCS#1 | 1 point location, distributed measurement to 6325 KB/5631 MSL | Continuous |
| | | CCS#2 | 1 point location, distributed measurement to 6211 KB/5520 MSL | Continuous |
| St. Peter | Fluid sampling | GM#2 | 1 point location, 1 interval: 3450 KB/2759 MSL | Baseline; Year 1-5: Annual |
| | Pressure/temperature monitoring | GM#2 | 1 point location, 1 interval: 3450 KB/2759 MSL | Continuous |
| | DTS | CCS#1 | 1 point location, distributed measurement to 6325 KB/5631 MSL | Continuous |
| | | CCS#2 | 1 point location, distributed measurement to 6211 KB/5520 MSL | Continuous |
| Ironton-Galesville | Fluid sampling | VW#1 | 1 point location, 1 interval: 4918 - 5000 KB, 4224 - 4306 MSL | Baseline; Year 1-3: Annual; Year 4-5: None |
| | | VW#2 | 1 point location, 1 interval: 5010 KB/4307 MSL | Baseline; Year 1-5: Annual |
| | Pressure/temperature monitoring | VW#1 | 1 point location, 1 interval: 4918 - 5000 KB, 4224 - 4306 MSL | Year 1-3: Continuous; Year 4-5: None |
| | | VW#2 | 1 point location, 1 interval: 4902 KB/4199 MSL | Continuous |
| | DTS | CCS#1 | 1 point location, distributed measurement to 6325 KB/5631 MSL | Continuous |
| | | CCS#2 | 1 point location, distributed measurement to 6211 KB/5520 MSL | Continuous |

Note 1: Baseline sampling and analysis will be completed before injection is authorized.

Note 2: Quarterly sampling will take place by the following dates each year: 3 months after the date of authorization of injection, 6 months after the date of authorization of injection, 9 months after the date of authorization of injection, and 12 months after the date of authorization of injection.

Note 3: Semi-annual sampling will be performed each year by: 6 months after the date of authorization of injection and 12 months after the date of authorization of injection.

Note 4: Annual sampling will occur up to 45 days before the anniversary date of authorization of injection each year.

Note 5: Continuous monitoring is described in Table 5 of this plan.

Table 8. Indirect Monitoring of Groundwater Quality and Geochemical Changes above the Confining Zone

| Target Formation | Monitoring Activity | Monitoring Location(s) | Spatial Coverage | Frequency ^(1,2) |
|--|---|------------------------|--|----------------------------|
| Quaternary and/or Pennsylvanian strata | Pulse Neutron Logging/ Reservoir Saturation Tool (RST) logs | VW#1 | 1 point location (12 inches outside well bore) & continuous to full well depth | Baseline, Year 2, Year 4 |
| | | VW#2 | 1 point location (6-12 inches outside well bore) & continuous to full well depth | Baseline, Year 2, Year 4 |
| | | CCS#1 | 1 point location (6-12 inches outside well bore) & continuous to full well depth | Baseline, Year 2, Year 4 |
| | | CCS#2 | 1 point location (6-12 inches outside well bore) & continuous to full well depth | Baseline, Year 2, Year 4 |
| St. Peter | Pulse Neutron Logging/RST | VW#1 | 1 point location (12 inches outside well bore) & continuous to full well depth | Baseline, Year 2, Year 4 |
| | | VW#2 | 1 point location (6-12 inches outside well bore) & continuous to full well depth | Baseline, Year 2, Year 4 |
| | | CCS#1 | 1 point location (6-12 inches outside well bore) & continuous to full well depth | Baseline, Year 2, Year 4 |
| | | CCS#2 | 1 point location (6-12 inches outside well bore) & continuous to full well depth | Baseline, Year 2, Year 4 |
| Ironton-Galesville | Pulse Neutron Logging/RST | VW#1 | 1 point location (12 inches outside well bore) & continuous to full well depth | Baseline, Year 2, Year 4 |
| | | VW#2 | 1 point location (6-12 inches outside well bore) & continuous to full well depth | Baseline, Year 2, Year 4 |
| | | CCS#1 | 1 point location (6-12 inches outside well bore) & continuous to full well depth | Baseline, Year 2, Year 4 |
| | | CCS#2 | 1 point location (6-12 inches outside well bore) & continuous to full well depth | Baseline, Year 2, Year 4 |

Note 1: Baseline sampling and analysis will be completed before injection is authorized.

Note 2: Logging will take place up to 45 days before the anniversary date of authorization of injection each year or will be alternatively scheduled with the prior approval of the UIC Program Director.

Table 9 identifies the parameters to be monitored and the analytical methods ADM will employ.

Table 9. Summary of analytical and field parameters for groundwater samples.

| Parameters | Analytical Methods ⁽¹⁾ |
|--|--|
| <i>Quaternary/Pennsylvanian</i> | |
| Cations: Al, Ba, Mn, As, Cd, Cr, Cu, Pb, Sb Se, and Tl | ICP-MS, EPA Method 6020 |
| Cations: Ca, Fe, K, Mg, Na, and Si | ICP-OES, EPA Method 6010B |
| Anions: Br, Cl, F, NO ₃ , and SO ₄ | Ion Chromatography, EPA Method 300.0 |
| Dissolved CO₂ | Coulometric titration, ASTM D513-11 |
| Total Dissolved Solids | Gravimetry; APHA 2540C |
| Alkalinity | APHA 2320B |
| pH (field) | EPA 150.1 |
| Specific conductance (field) | APHA 2510 |
| Temperature (field) | Thermocouple |
| <i>St. Peter</i> | |
| Cations: Al, Ba, Mn, As, Cd, Cr, Cu, Pb, Sb Se, and Tl | ICP-MS, EPA Method 6020 |
| Cations: Ca, Fe, K, Mg, Na, and Si | ICP-OES, EPA Method 6010B |
| Anions: Br, Cl, F, NO ₃ , and SO ₄ | Ion Chromatography, EPA Method 300.0 |
| Dissolved CO₂ | Coulometric titration, ASTM D513-11 |
| Isotopes: δ ¹³ C of DIC | Isotope ratio mass spectrometry |
| Total Dissolved Solids | Gravimetry; APHA 2540C |
| Water Density (field) | Oscillating body method |
| Alkalinity | APHA 2320B |
| pH (field) | EPA 150.1 |
| Specific conductance (field) | APHA 2510 |
| Temperature (field) | Thermocouple |
| <i>Ironton-Galesville</i> | |
| Cations: Al, Ba, Mn, As, Cd, Cr, Cu, Pb, Sb Se, and Tl | ICP-MS, EPA Method 6020 |
| Cations: Ca, Fe, K, Mg, Na, and Si | ICP-OES, EPA Method 6010B |

| Parameters | Analytical Methods ⁽¹⁾ |
|--|---|
| Anions: Br, Cl, F, NO ₃ , and SO ₄ | Ion Chromatography, EPA Method 300.0 |
| Dissolved CO₂ | Coulometric titration, ASTM D513-11 |
| Isotopes: δ ¹³ C of DIC | Isotope ratio mass spectrometry |
| Total Dissolved Solids | Gravimetry; APHA 2540C |
| Water Density(field) | Oscillating body method |
| Alkalinity | APHA 2320B |
| pH (field) | EPA 150.1 |
| Specific conductance (field) | APHA 2510 |
| Temperature (field) | Thermocouple |

Note 1: ICP = inductively coupled plasma; MS = mass spectrometry; OES = optical emission spectrometry; GC-P = gas chromatography - pyrolysis. An equivalent method may be employed with the prior approval of the UIC Program Director.

Sampling will be performed as described in Section B.2 of the QASP; this section of the QASP describes the groundwater sampling methods to be employed, including sampling SOPs (Section B.2.a/b), and sample preservation (Section B.2.g).

Sample handling and custody will be performed as described in Section B.3 of the QASP.

Quality control will be ensured using the methods described in Section B.5 of the QASP.

External Mechanical Integrity Tests (MITs)

ADM will conduct at least one of the tests presented in Table 10 during the injection phase to verify external MI as required at 40 CFR 146.89(c) and 146.90. MITs will be performed annually, up to 45 days before the anniversary date of authorization of injection each year or alternatively scheduled with the prior approval of the UIC Program Director.

Table 10. MITs.

| Test Description | Location |
|-----------------------|---|
| Temperature Log | Along wellbore using DTS or wireline well log |
| Noise Log | Wireline Well Log |
| Oxygen Activation Log | Wireline Well Log |

Description of MIT(s) That May be Employed

Temperature Logging Using Wireline

To ensure the mechanical integrity of the casing of the injection well, temperature data will be recorded across the wellbore from surface down to primary caprock. Bottom hole pressure data near the packer will also be provided. The following procedures, as described in Appendix G of the CCS #2 permit application, will be employed for temperature logging:

The well should be in a state of injection for at least 6 hours prior to commencing operations in order to cool injection zones.

1. Move in and rig up an electrical logging unit with lubricator.
2. Run a temperature survey from the Base of the Maquoketa Formation (or higher) to the deepest point reachable in the Mt. Simon while injecting at a rate that allows for safe operations.²
3. Stop injection, pull tool back to shallow depth, wait 1 hour.
4. Run a temperature survey over the same interval as step 2.
5. Pull tool back to shallow depth, wait 2 hours.
6. Run a temperature survey over the same interval as step 2.
7. Pull tool back to shallow depth, wait 2 hours.
8. Run a temperature survey over the same interval as step 2.
9. Evaluate data to determine if additional passes are needed for interpretation. Should CO₂ migration be interpreted in the top most section of the log, additional logging runs over a higher interval will be required to find the top of migration.
10. If additional passes are needed, repeat temperature surveys every 2 hours until 12 hours, over the same interval as step 2.
11. Rig down the logging equipment.
12. Data interpretation involves comparing the time lapse well temperature profiles and looking for temperature anomalies that may indicate a failure of well integrity; i.e. tubing leak or movement of fluid behind the casing. As the well cools down the temperature profile along the length of the tubing string is compared to the baseline. Any unplanned fluid movement into the annulus or outside the casing creates a temperature anomaly when compared to the baseline cooling profile.

Temperature Logging Using DTS Fiber Optic Line

CCS#2 is equipped with a DTS fiber optic temperature monitoring system that is capable of monitoring the injection well's annular temperature along the length of the tubing string. The DTS line is used for real time temperature monitoring and, like a conventional temperature log,

² Should operational constraints or safety concerns not allow for a logging pass while injecting, an acceptable, alternate plan is to stop injecting immediately prior to the first logging pass.

can be used for early detection of temperature changes that may indicate a loss of well mechanical integrity. The procedure for using the DTS for well mechanical integrity is as follows:

1. After the well is completed and prior to injection, a baseline temperature profile will be established. This profile represents the natural temperature gradient for each stratigraphic zone.
2. During injection operation, record the temperature profile for 6 hours prior to shutting in well.
3. Stop injection and record temperature profile for 6 hours.
4. Evaluate data to determine if additional cooling time is needed for interpretation.
5. Start injection and record temperature profile for 6 hours.
6. Data interpretation involves comparing the time lapse well temperature profiles and looking for temperature anomalies that may indicate a failure of well integrity; i.e. tubing leak or movement of fluid behind the casing. The DTS system monitors and records the well's temperature profiles at a pre-set frequency in real time. As the well cools down the temperature profile along the length of the tubing string is compared to the baseline. Any unplanned fluid movement into the annulus or outside the casing creates a temperature anomaly when compared to the baseline cooling profile. This data can be continuously monitored to provide real time MIT surveillance making this technology superior to wireline temperature logging.

Noise Logging

To ensure the mechanical integrity of the casing of the injection well, logging data will be recorded across the wellbore from surface down to primary caprock. Bottom hole pressure data near the packer will also be provided. Noise logging will be carried out while injection is occurring. If ambient noise is greater than 10 mv, injection will be halted. The following procedures will be employed:

1. Move in and rig up an electrical logging unit with lubricator.
2. Run a noise survey from the Base of the Maquoketa Formation (or higher) to the deepest point reachable in the Mt. Simon while injecting at a rate that allows for safe operations.
3. Make noise measurements at intervals of 100 feet to create a log on a coarse grid.
4. If any anomalies are evident on the coarse log, construct a finer grid by making noise measurements at intervals of 20 feet within the coarse intervals containing high noise levels.
5. Make noise measurements at intervals of 10 feet through the first 50 feet above the injection interval and at intervals of 20 feet within the 100-foot intervals containing:
 - a. The base of the lowermost bleed-off zone above the injection interval and
 - b. The base of the lowermost USDW (St. Peter).
6. Additional measurements may be made to pinpoint depths at which noise is produced.

7. Use a vertical scale of 1 or 2 inches per 100 feet.
8. Rig down the logging equipment.
9. Interpret the data as follows: Determine the base noise level in the well (dead well level). Identify departures from this level. An increase in noise near the surface due to equipment operating at the surface is to be expected in many situations. Determine the extent of any movement; flow into or between USDWs indicates a lack of mechanical integrity; flow from the injection zone into or above the confining zone indicates a failure of containment.

Oxygen Activation (OA) Logging

To ensure the mechanical integrity of the casing of the injection well, logging data will be recorded across the wellbore from surface down to primary caprock. Bottom hole pressure data near the packer will also be provided. OA logging will be carried out while injection is occurring. The following procedures will be employed:

1. Move in and rig up an electrical logging unit with lubricator.
2. Conduct a baseline Gamma Ray Log and casing collar locator log from the top of the injection zone to the surface prior to taking the stationary readings with the OA tool.³
3. The OA log shall be used only for casing diameters of greater than 1-11/16 inches and less than 13- 3/8 inches.
4. All stationary readings should be taken with the well injecting fluid at the normal rate with minimal rate and pressure fluctuations.
5. Prior to taking the stationary readings, the OA tool must be properly calibrated in a “no vertical flow behind the casing” section of the well to ensure accurate, repeatable tool response and for measuring background counts.
6. Take, at a minimum, a 15 minute stationary reading adjacent to the confining interval located immediately above the injection interval. This must be at least 10 feet above the injection interval so that turbulence does not affect the readings.
7. Take, at a minimum, a 15 minute stationary reading at a location approximately midway between the base of the lowermost USDW and the confining interval located immediately above the injection interval.
8. Take, at a minimum, a 15 minute stationary reading adjacent to the top of the confining zone.
9. Take, at a minimum, a 15 minute stationary reading at the base of the lowermost USDW.
10. If flow is indicated by the OA log at a location, move uphole or downhole as necessary at no more than 50 foot intervals and take stationary readings to determine the area of fluid migration.

³ Gamma Ray Log is necessary to evaluate the contribution of naturally occurring background radiation to the total gamma radiation count detected by the OA tool. There are different types of natural radiation emitted from various geologic formations or zones and the natural radiation may change over time.

11. Interpret the data: Identification of differences in the activated water's measured gamma ray count-rate profile versus the expected count-rate profile for a static environment. Differences between the measured and expected may indicate flow in the annulus or behind the casing. The flow velocity is determined by measuring the time that the activated water passes a detector.

Pressure Fall-Off Testing

ADM will perform pressure fall-off tests during the injection phase as described below to meet the requirements of 40 CFR 146.90(f).

Pressure fall-off testing will be performed:

- During injection, approximately half way through the injection phase (i.e., year 2.5); and
- At the end of the injection period.

ADM will conduct pressure fall-off testing according to the procedures below, as described in Section 6A.3.4 of the CCS #2 permit application.

Pressure Fall-off Test Procedure

A pressure falloff test has a period of injection followed by a period of no-injection or shut-in. Normal injection using the stream of CO₂ captured from the ADM facility will be used during the injection period preceding the shut-in portion of the falloff tests. The normal injection rate is estimated to be 2,750 MT/day (the last 3 years of the planned 5-year injection period). Prior to the falloff test this rate will be maintained. If this rate causes relatively large changes in bottomhole pressure, the rate may be decreased. Injection will have occurred for 2.5 years prior to this test, but there may have been injection interruptions due to operations or testing. At a minimum, one week of relatively continuous injection will precede the shut-in portion of the falloff test; however, several months of injection prior to the falloff will likely be part of the pre-shut-in injection period and subsequent analysis. This data will be measured using a surface readout downhole gauge so a final decision on test duration can be made after the data is analyzed for average pressure. The gauges may be those used for day-to-day data acquisition or a pressure gauge will be conveyed via electric line (e-line).

To reduce the wellbore storage effects attributable to the pipeline and surface equipment, the well will be shut-in at the wellhead nearly instantaneously with direct coordination with the injection compression facility operator. Because surface readout will be used and downhole recording memory restrictions will be eliminated, data will be collected at five second intervals or less for the entire test. The shut-in period of the falloff test will be at least four days or longer until adequate pressure transient data are collected to calculate the average pressure. Because surface readout gauges will be used, the shut-in duration can be determined in real-time. A report containing the pressure falloff data and interpretation of the reservoir ambient pressure will be submitted to the permitting agency within 90 days of the test. Pressure sensors used for this test will be the wellhead sensors and a downhole gauge for the pressure falloff test. Each gauge will be of a type that meets or exceeds ASME B 40.1 Class 2A (0.5% accuracy across full range). Wellhead pressure gauge range will be 0-4,000 psi. Downhole gauge range will be 0-10,000 psi.

Carbon Dioxide Plume and Pressure Front Tracking

ADM will employ direct and indirect methods to track the extent of the carbon dioxide plume and the presence or absence of elevated pressure during the operation period to meet the requirements of 40 CFR 146.90(g).

Table 11 and Table 12 present the direct and indirect methods that ADM will use to monitor the position of the CO₂ plume and pressure front, including the activities, locations, and frequencies ADM will employ.

ADM will conduct fluid sampling and analysis to detect changes in groundwater in order to directly monitor the carbon dioxide plume. The parameters to be analyzed as part of fluid sampling in the Mt. Simon (i.e., the injection zone) and analytical methods are presented in

Pressure at Top of CCS2 Injection Interval

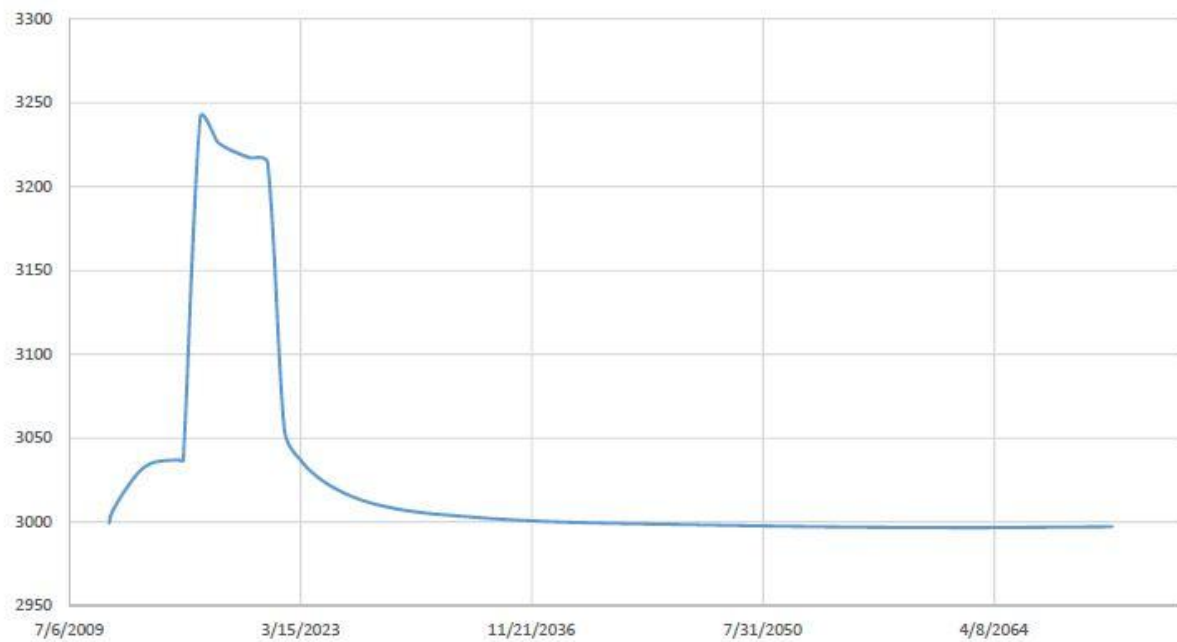

Figure 10. Predicted pressure profile at the top of the CCS#2 injection interval, simulated for 50 years after the commencement of injection.

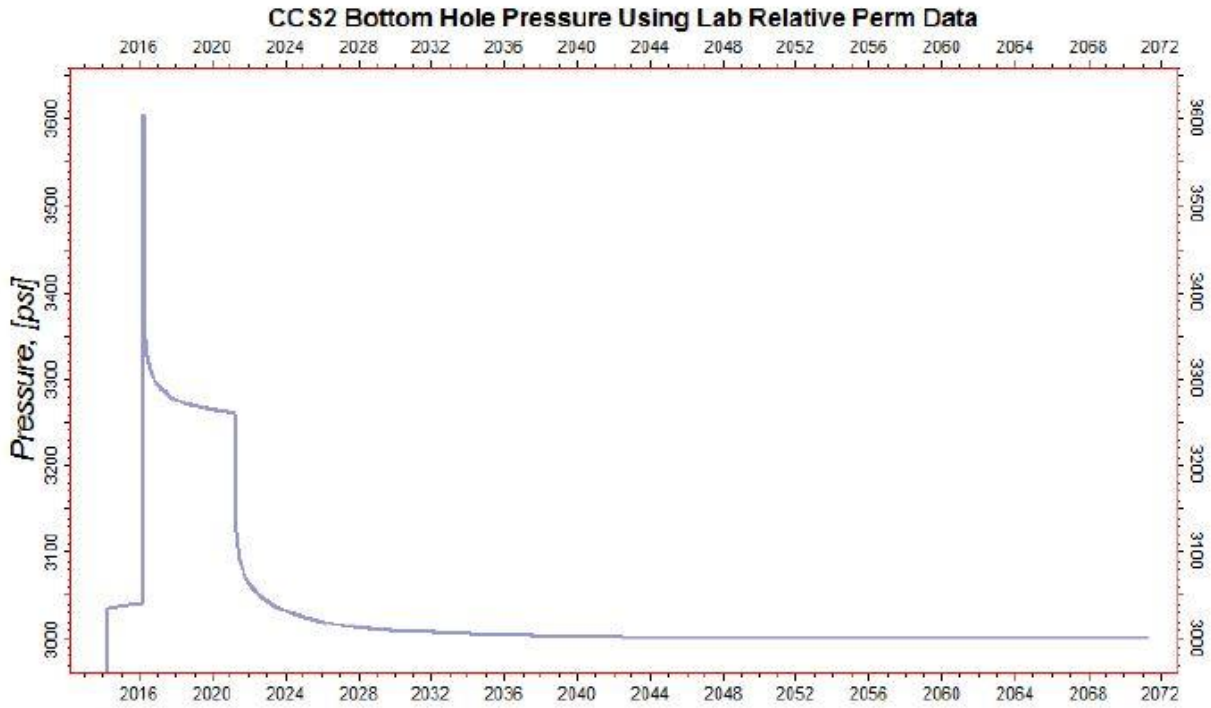

Figure 11. Predicted CCS#2 bottom-hole pressure profile, simulated for 50 years after the commencement of injection.

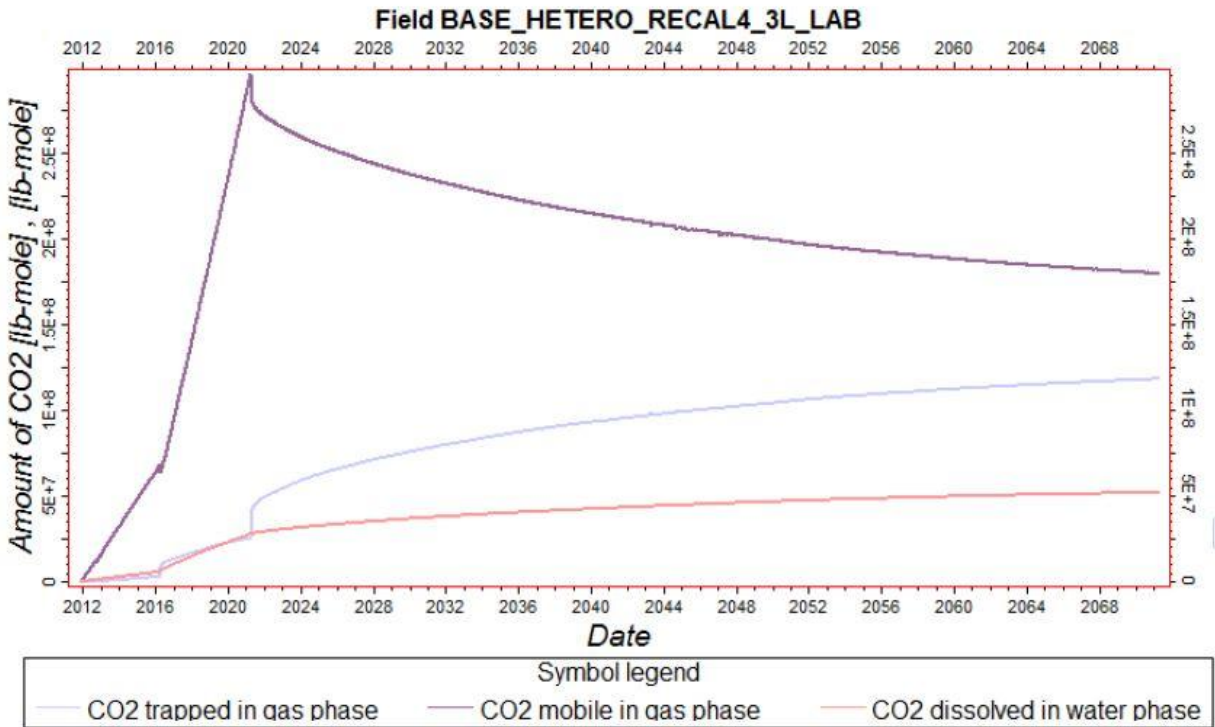

Figure 12. Predicted CO₂ phase distribution, simulated for 50 years after the commencement of injection.

. ADM will deploy pressure/temperature monitors and DTS to directly monitor the position of the pressure front.

Indirect plume monitoring will be employed using pulsed neutron capture/RST logs to monitor CO₂ saturation. Time-lapse 3D vertical seismic profiles (VSPs) will be used to image the developing CO₂ plume for indirect plume monitoring. Passive seismic monitoring combination of borehole and surface seismic stations to detect local events over M 1.0 within the AoR will also be performed. Quality assurance procedures for seismic monitoring methods are presented in Section B.9 of the QASP.

Table 11. Plume Monitoring Activities.

| Target Formation | Monitoring Activity | Monitoring Location(s) | Spatial Coverage | Frequency ⁽¹⁻⁴⁾ |
|----------------------------------|---------------------------|---|--|-------------------------------|
| Direct Plume Monitoring | | | | |
| Mt. Simon | Fluid sampling | VW#1 | 1 point location, 1 interval: 6837 - 6632 KB, 6148 - 5938 MSL | Baseline; Year 1-3: Annual |
| | | VW#2 | 1 point location, 3 intervals: 6710, 6500, 5810 KB; 6007, 5797, 5107 MSL | Annual |
| Indirect Plume Monitoring | | | | |
| Mt. Simon | Pulse Neutron Logging/RST | VW#1 | 1 point location (12" outside wellbore) & continuous to full well depth | Baseline, Year 2, Year 4 |
| | | VW#2 | 1 point location (12" outside wellbore) & continuous to full well depth | Baseline, Year 2, Year 4 |
| | | CCS#1 | 1 point location (12" outside wellbore) & continuous to full well depth | Baseline, Year 2, Year 4 |
| | | CCS#2 | 1 point location (12" outside wellbore) & continuous to full well depth | Baseline, Year 2, Year 4 |
| Mt Simon | Time-lapse VSP survey | GM#1 | Fold Image Coverage ~ 30 acres | In 2013, 2014, 2015 |
| | 3D surface seismic survey | Full coverage focusing on the northern extent of plume area | Fold Image Coverage ~ 2,000 acres | Baseline, Year 2 (2019) |

Note 1: Baseline monitoring will be completed before injection is authorized.

Note 2: Annual monitoring will be performed up to 45 days before the anniversary date of authorization of injection each year or alternatively scheduled with the prior approval of the UIC Program Director.

Note 3: Logging surveys will take place up to 45 days before the anniversary date of authorization of injection each year or alternatively scheduled with the prior approval of the UIC Program Director.

Note 4: Seismic surveys will be performed in the 4th quarter before or the 1st quarter of the calendar year shown or alternatively scheduled with the prior approval of the UIC Program Director.

Table 12. Pressure-Front Monitoring Activities

| Target Formation | Monitoring Activity | Monitoring Location(s) | Spatial Coverage | Frequency |
|--|--|--|--|---|
| Direct Pressure-Front Monitoring | | | | |
| Mt. Simon | Pressure/ temperature monitoring | VW#1 | 1 point location, 1 interval: 6945 - 5654 KB, 6251 - 4960 MSL | Year 1-3: Continuous; Year 4-5: None |
| | | VW#2 | 1 point location, 4 intervals: 7041, 6681, 6524, 5848 KB; 6338, 5978, 5821, 5145 MSL | Continuous |
| | | CCS#1 | 1 point location, 1 interval: PT @ 6325 KB/5631 MSL; Perfs @ 6982 - 7050 KB, 6288 - 6356 MSL | Continuous |
| | | CCS#2 | 1 point location, 1 interval: PT @ 6270 KB/5579 MSL; Perfs @ 6630 - 6825 KB, 5939 - 6134 MSL | Continuous |
| | DTS | CCS#1 | 1 point location, distributed measurement to 6325 KB/5631 MSL. | Continuous |
| | | CCS#2 | 1 point location, distributed measurement to 6211 KB/5520 MSL. | Continuous |
| Other Plume/Pressure-Front Monitoring | | | | |
| Multiple | Passive seismic | A combination of borehole and surface seismic stations located within the AoR. | The passive seismic monitoring system has the ability to detect seismic events over M1.0 within the AoR. | Continuous |

Table 13. Summary of analytical and field parameters for fluid sampling in the Mt. Simon.

| Parameters | Analytical Methods ⁽¹⁾ |
|--|---|
| Cations: Al, Ba, Mn, As, Cd, Cr, Cu, Pb, Sb Se, and Tl | ICP-MS, EPA Method 6020 |
| Cations: Ca, Fe, K, Mg, Na, and Si | ICP-OES, EPA Method 6010B |
| Anions: Br, Cl, F, NO ₃ , and SO ₄ | Ion Chromatography, EPA Method 300.0 |
| Dissolved CO ₂ | Coulometric titration, ASTM D513-11 |
| Isotopes: δ ¹³ C of DIC | Isotope ratio mass spectrometry |
| Total Dissolved Solids | Gravimetry; APHA 2540C |
| Water Density (field) | Oscillating body method |
| Alkalinity | APHA 2320B |
| pH (field) | EPA 150.1 |

| Parameters | Analytical Methods ⁽¹⁾ |
|-------------------------------------|--|
| Specific conductance (field) | APHA 2510 |
| Temperature (field) | Thermocouple |

Note 1: ICP = inductively coupled plasma; MS = mass spectrometry; OES = optical emission spectrometry; GC-P = gas chromatography - pyrolysis. An equivalent method may be employed with the prior approval of the UIC Program Director.

Monitoring locations relative to the predicted location of the CO₂ plume and pressure front at 1-year intervals throughout the injection phase are shown in Figure 4. Predicted extent of the CO₂ plume and pressure front (DPif = 62.2 psi) relative to monitoring locations, at the commencement of injection through Figure 9. Predicted pressure profiles at the top of the injection interval and bottom-hole pressure at CCS#2 are shown in Figure 10 and Figure 11. The predicted amount of CO₂ in the mobile gas, trapped gas, and dissolved (aqueous) phases for 50 years after the commencement of injection is shown in Figure 12.

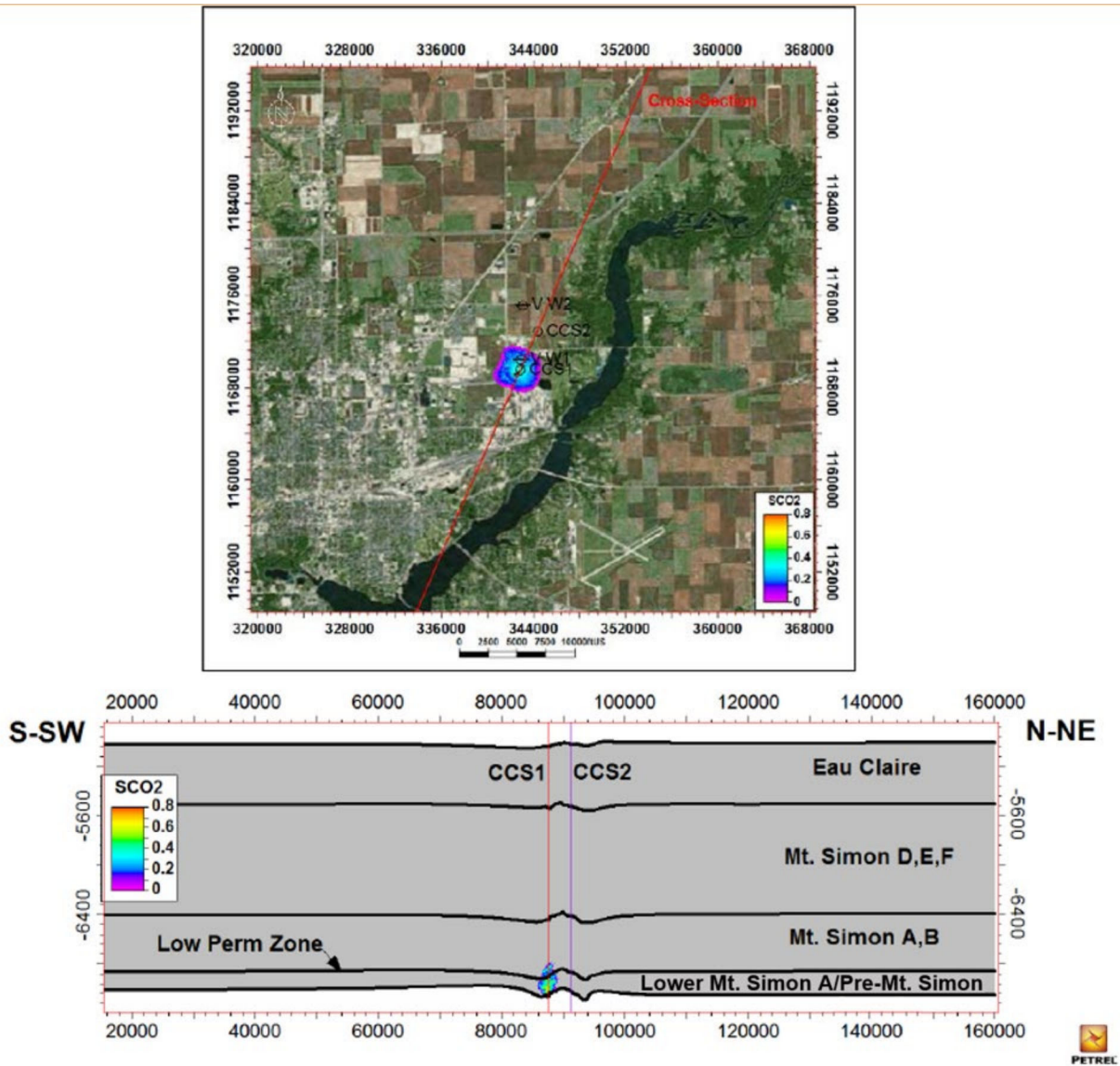

Figure 4. Predicted extent of the CO₂ plume and pressure front (DPif = 62.2 psi) relative to monitoring locations, at the commencement of injection for CCS #2.

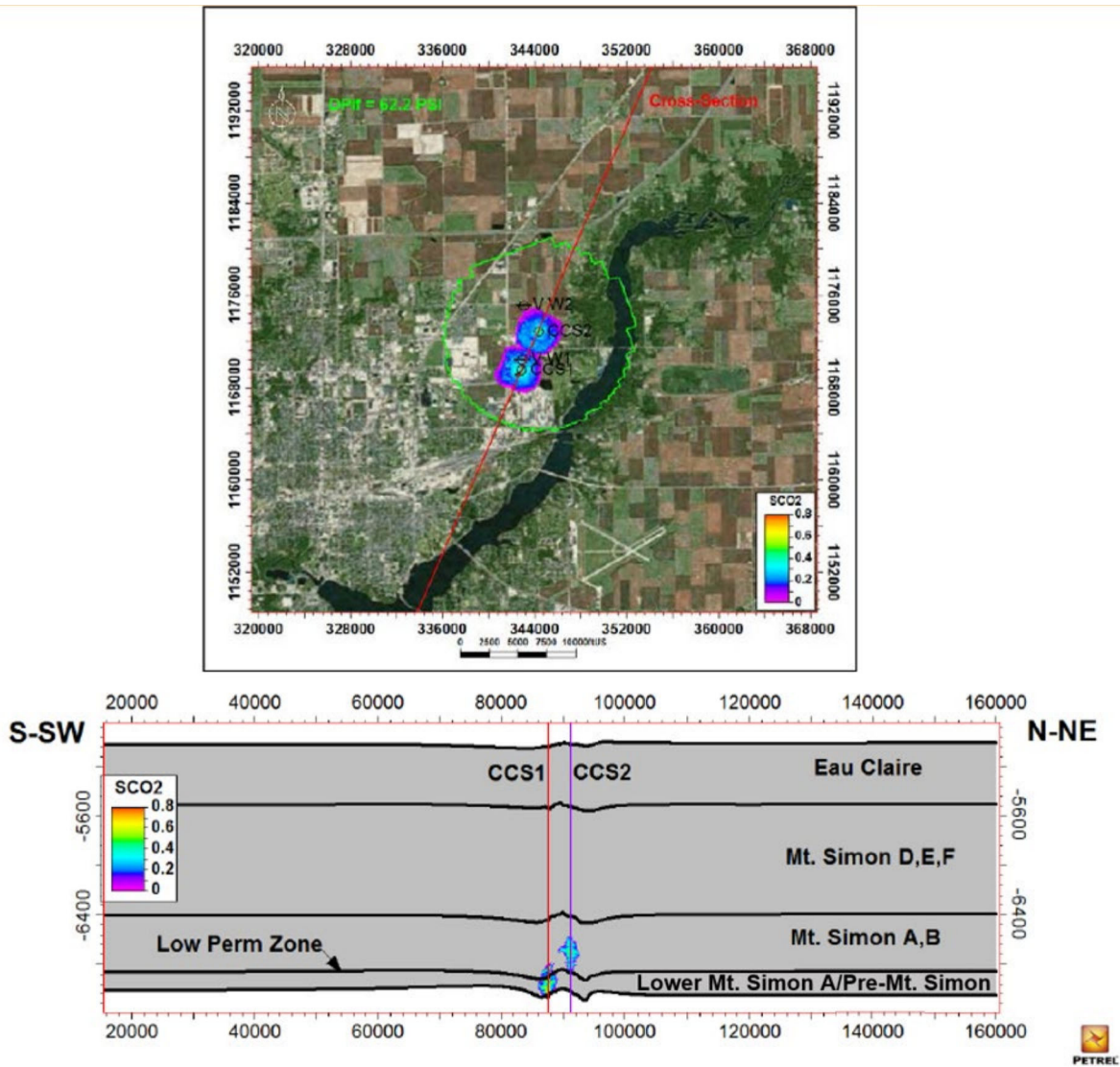

Figure 5. Predicted extent of the CO₂ plume and pressure front (DPif = 62.2 psi) relative to monitoring locations, after 1 year of injection at CCS #2.

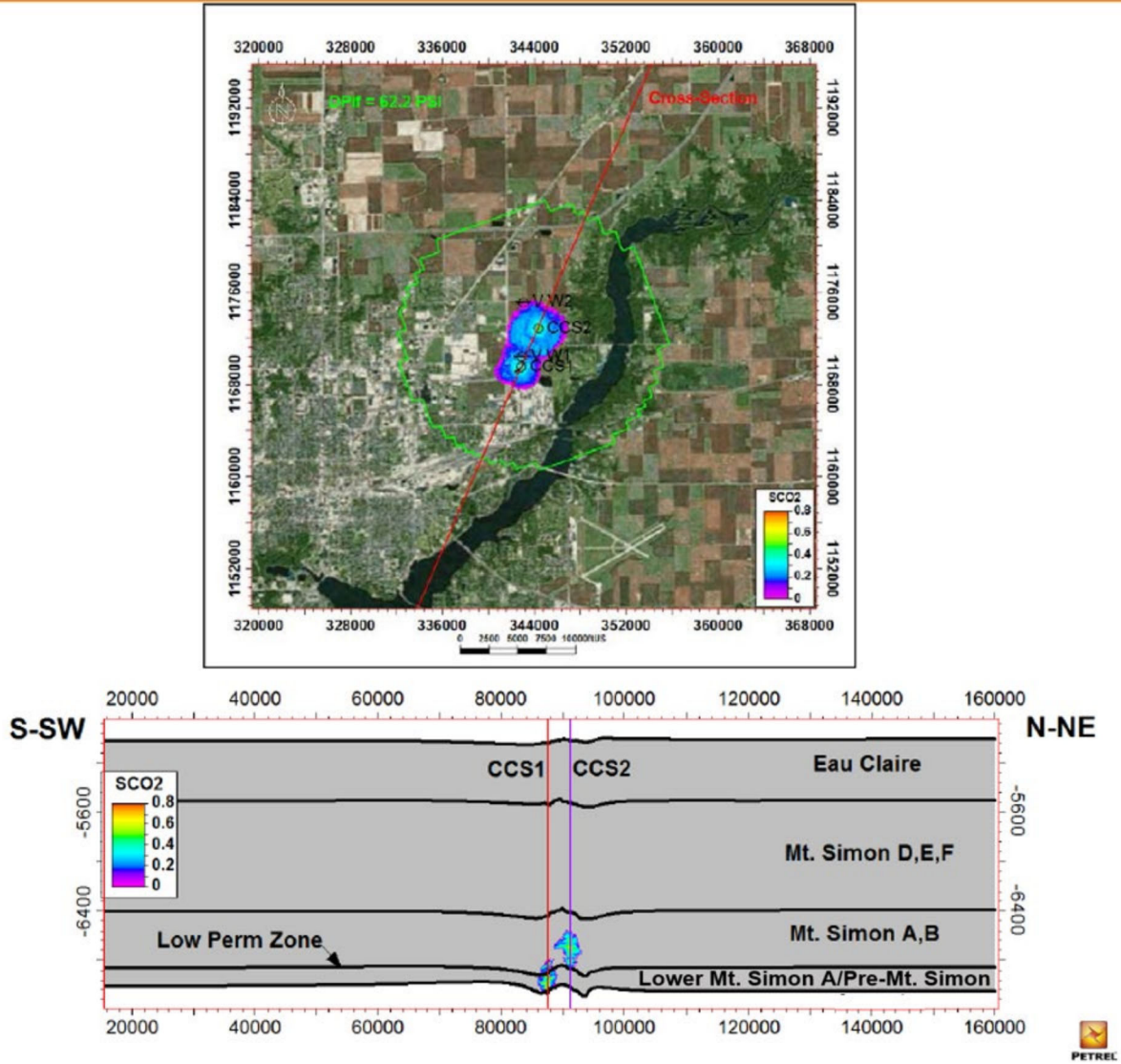

Figure 6. Predicted extent of the CO₂ plume and pressure front (DPif = 62.2 psi) relative to monitoring locations, after 2 years of injection at CCS #2.

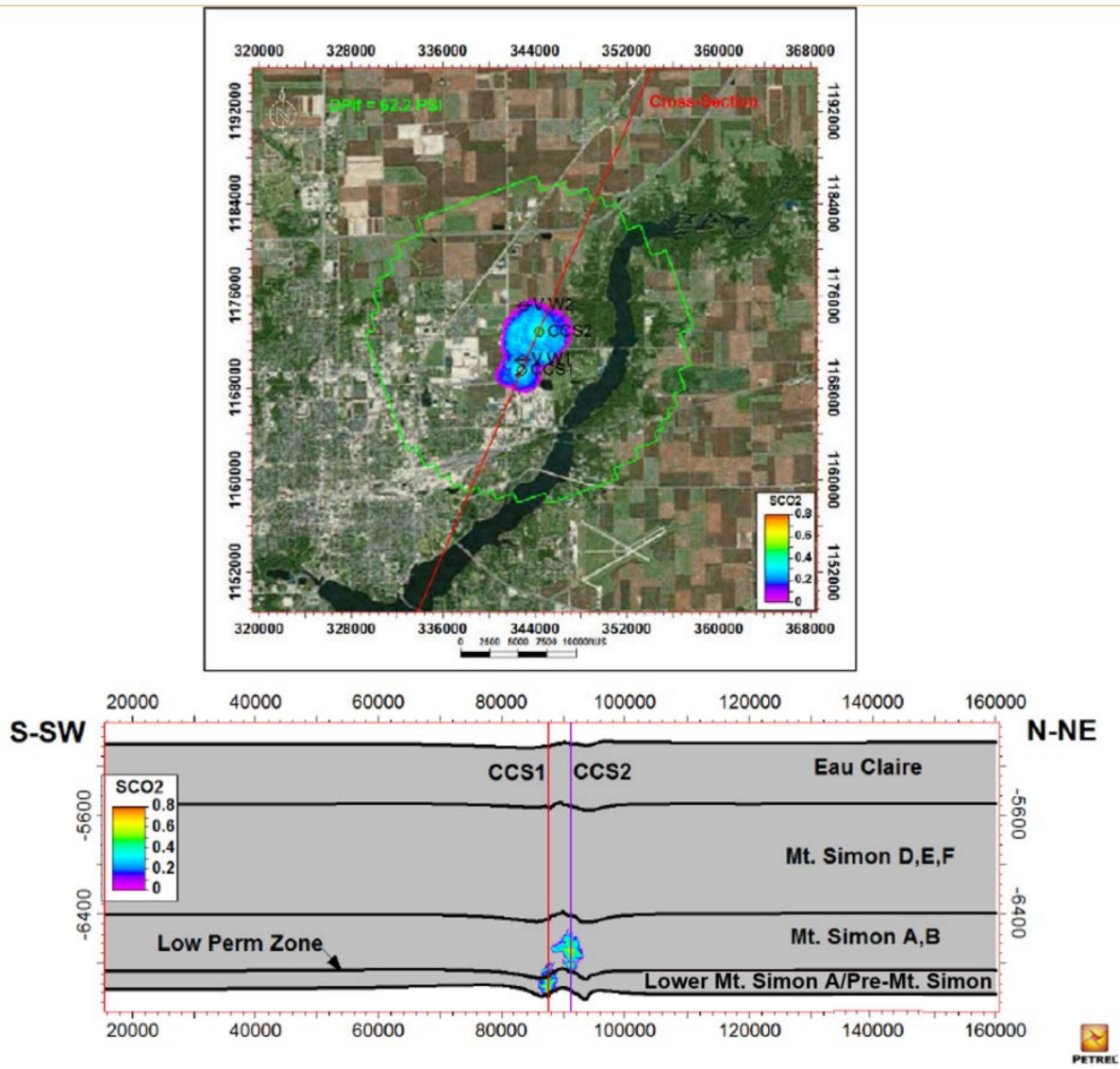

Figure 7. Predicted extent of the CO₂ plume and pressure front (DPif = 62.2 psi) relative to monitoring locations, after 3 years of injection at CCS #2.

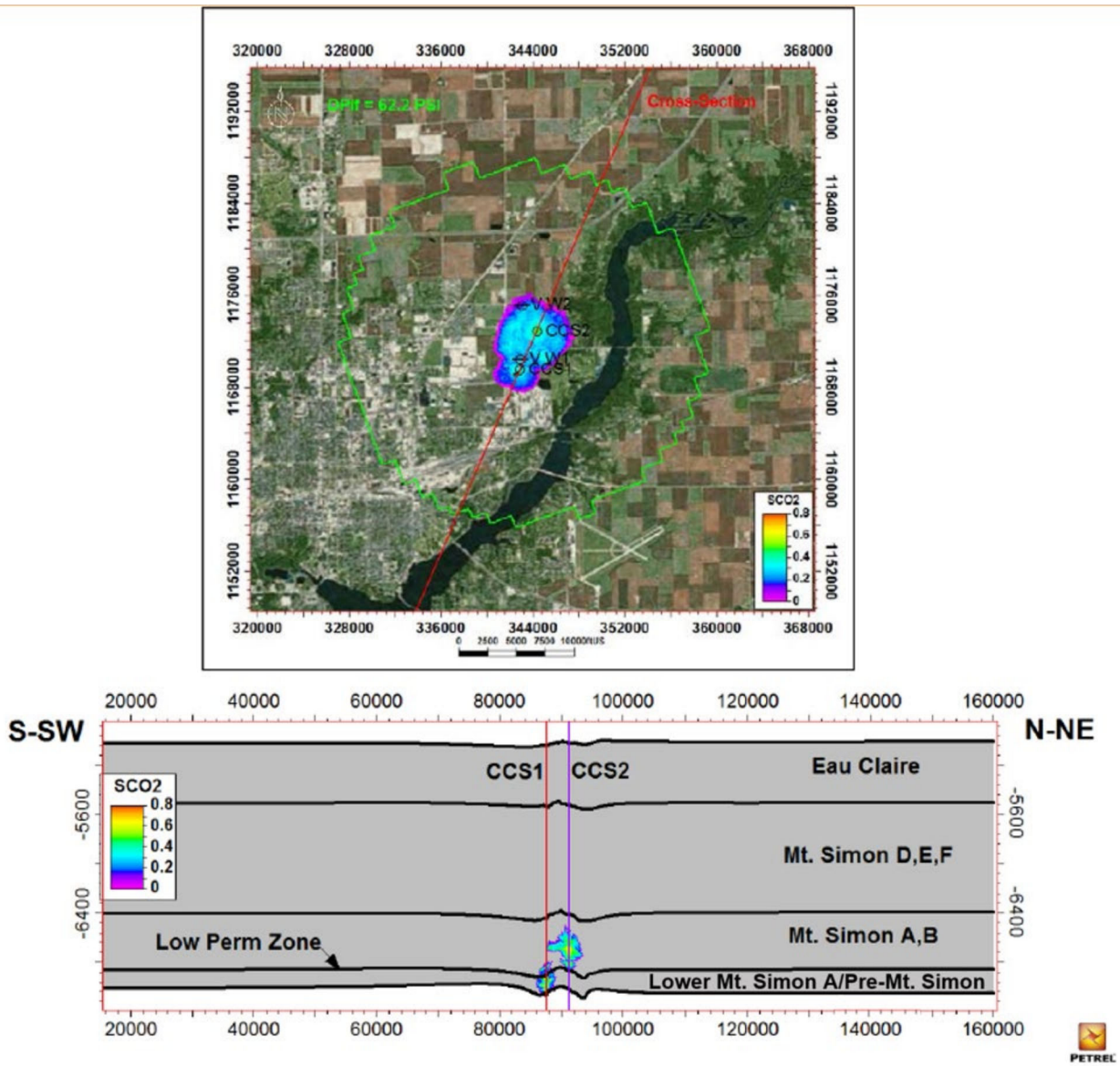

Figure 8. Predicted extent of the CO₂ plume and pressure front (DPif = 62.2 psi) relative to monitoring locations, after 4 years of injection at CCS #2.

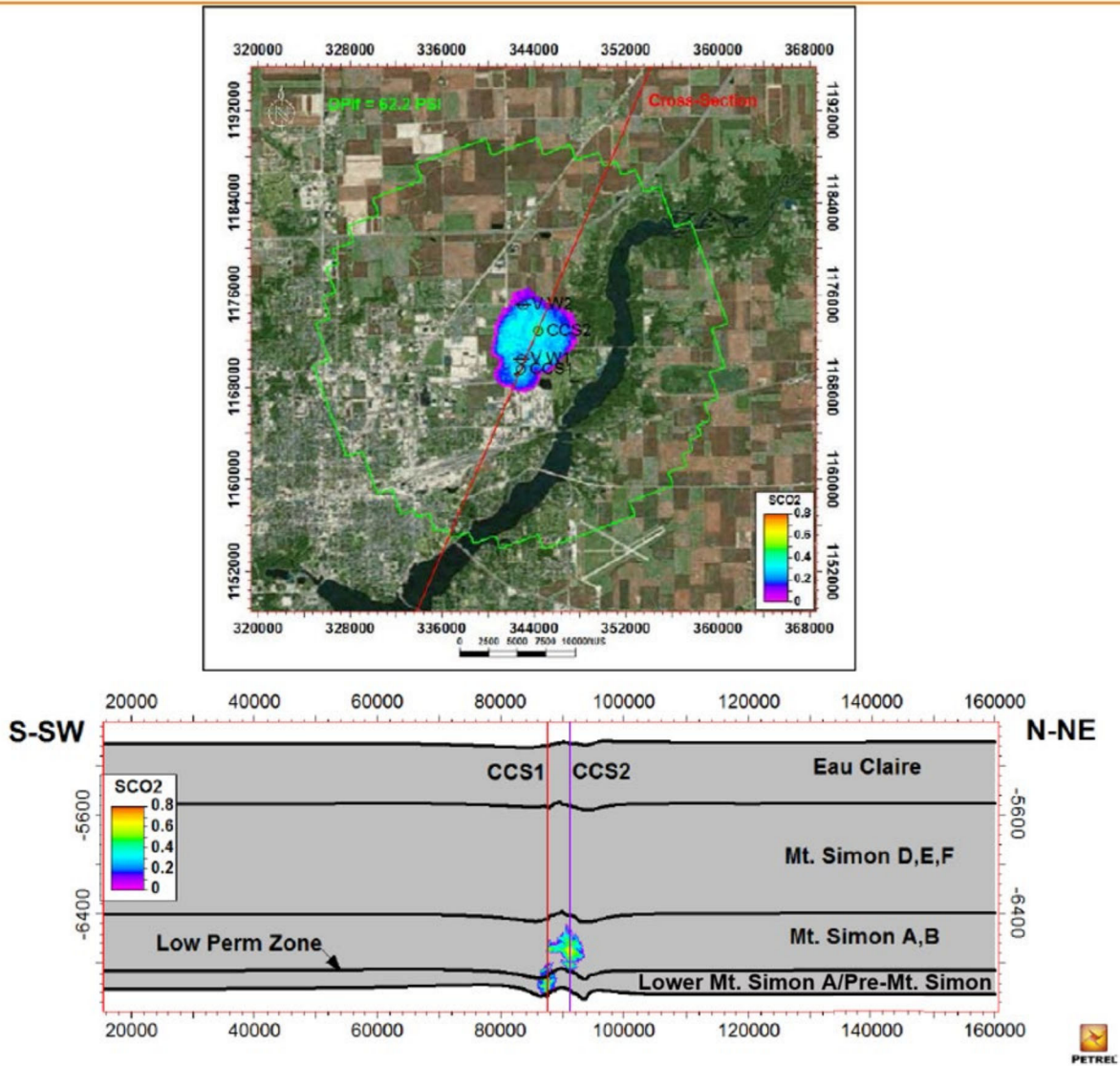

Figure 9. Predicted extent of the CO₂ plume and pressure front (DPif = 62.2 psi) relative to monitoring locations, after 5 years of injection at CCS #2.

Pressure at Top of CCS2 Injection Interval

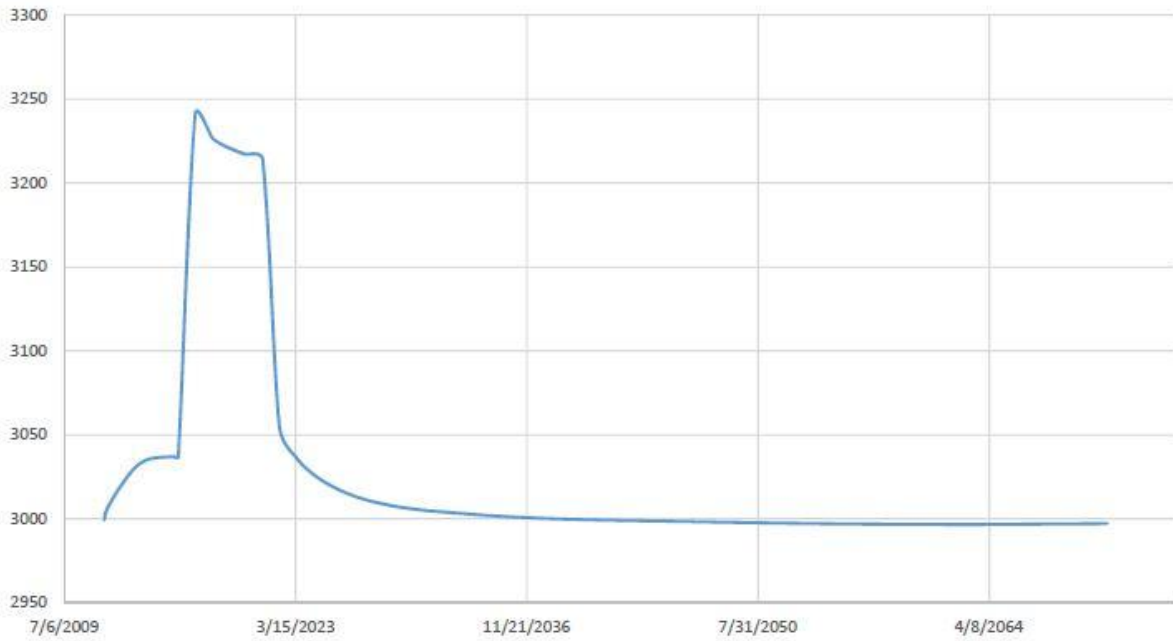

Figure 10. Predicted pressure profile at the top of the CCS#2 injection interval, simulated for 50 years after the commencement of injection.

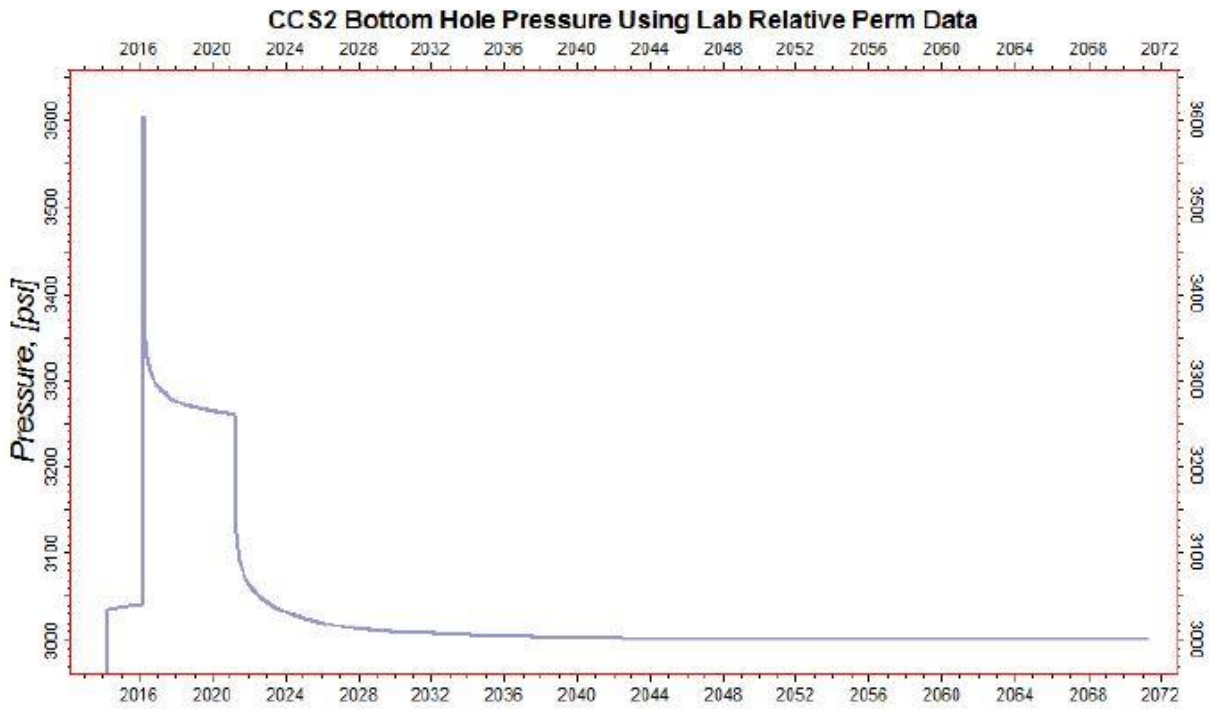

Figure 11. Predicted CCS#2 bottom-hole pressure profile, simulated for 50 years after the commencement of injection.

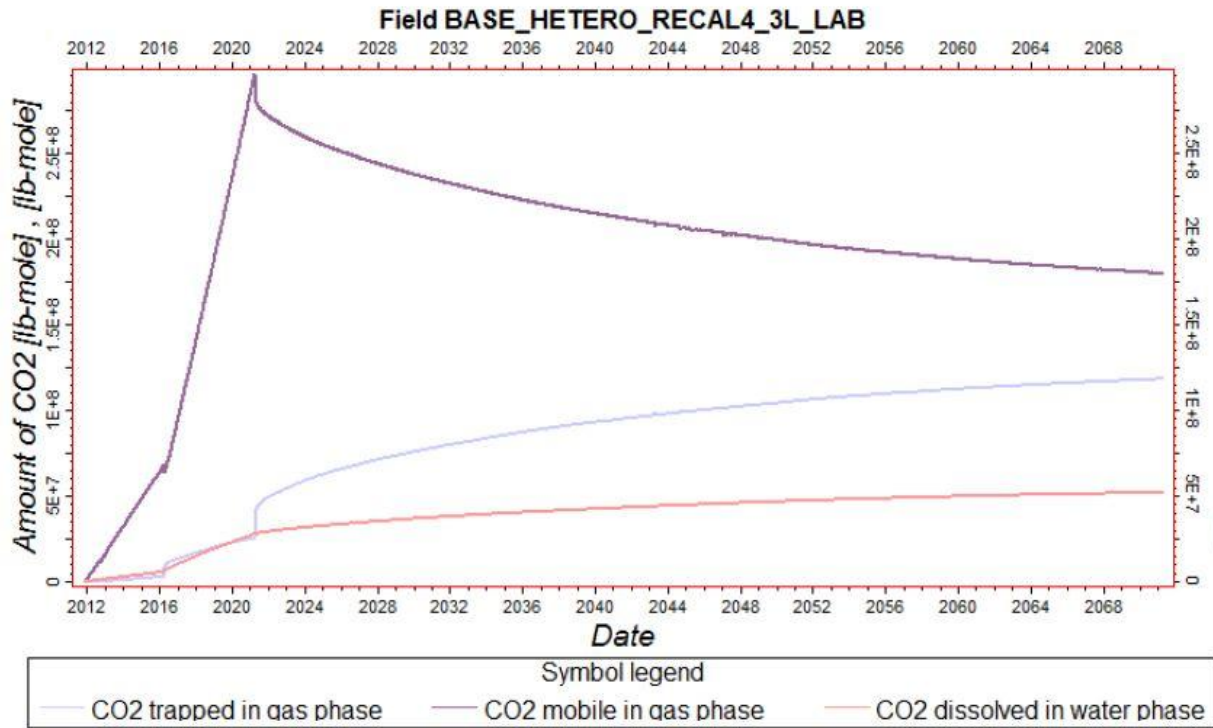

Figure 12. Predicted CO₂ phase distribution, simulated for 50 years after the commencement of injection.

Appendix

Quality Assurance and Surveillance Plan.

Illinois Industrial Carbon Capture and Sequestration (IL-ICCS) Project
Class VI Injection Well: Quality Assurance and Surveillance Plan

U.S. EPA ID Number (IL-115-6A-0001)

October 2016

Prepared by:
Archer Daniels Midland Company (ADM)

Table of Contents

| | |
|---|-----------|
| A. PROJECT MANAGEMENT | 1 |
| A.1. Project/Task Organization | 1 |
| A.1.a/b. Key Individuals and Responsibilities | 1 |
| A.1.c. Independence from Project QA Manager and Data Gathering | 1 |
| A.1.d. QA Project Plan Responsibility | 1 |
| A.1.e. Organizational Chart for Key Project Personnel | 1 |
| A.2. Problem Definition/Background | 2 |
| A.2.a Reasoning | 2 |
| A.2.b. Reasons for Initiating the Project | 3 |
| A.2.c. Regulatory Information, Applicable Criteria, Action Limits | 3 |
| A.3. Project/Task Description | 3 |
| A.3.a/b. Summary of Work to be Performed and Work Schedule | 3 |
| A.3.c. Geographic Locations | 11 |
| A.3.d. Resource and Time Constraints | 12 |
| A.4. Quality Objectives and Criteria | 12 |
| A.4.a. Performance/Masurement Criteria | 12 |
| A.4.b. Precision | 20 |
| A.4.c. Bias | 20 |
| A.4.d. Representativeness | 20 |
| A.4.e. Completeness | 21 |
| A.4.f. Comparability | 21 |
| A.4.g. Method Sensitivity | 21 |
| A.5. Special Training/Certifications | 22 |
| A.5.a. Specialized Training and Certifications | 22 |
| A.5.b/c. Training Provider and Responsibility | 23 |
| A.6. Documentation and Records | 23 |
| A.6.a. Report Format and Package Information | 23 |
| A.6.b. Other Project Documents, Records, and Electronic Files | 23 |
| A.6.c/d. Data Storage and Duration | 23 |
| A.6.e. QASP Distribution Responsibility | 23 |
| B. DATA GENERATION AND ACQUISITION | 23 |

| | |
|---|-----------|
| B.1. Sampling Process Design (Experimental Design) | 23 |
| B.1.a. Design Strategy | 24 |
| CO ₂ Stream Monitoring Strategy | 24 |
| Corrosion Monitoring Strategy | 24 |
| Shallow Groundwater Monitoring Strategy | 24 |
| Deep Groundwater Monitoring Strategy | 24 |
| GM#2 Sampling | 25 |
| VW#1 Sampling | 25 |
| VW#2 Sampling | 25 |
| B.1.b Type and Number of Samples/Test Runs | 25 |
| B.1.c. Site/Sampling Locations | 26 |
| B.1.d. Sampling Site Contingency | 26 |
| B.1.e. Activity Schedule | 26 |
| B.1.f. Critical/Informational Data | 26 |
| B.1.g. Sources of Variability | 26 |
| | |
| B.2. Sampling Methods | 27 |
| B.2.a/b. Sampling SOPs | 27 |
| B.2.c. In-situ Monitoring. | 28 |
| B.2.d. Continuous Monitoring. | 28 |
| B.2.e. Sample Homogenization, Composition, Filtration. | 28 |
| B.2.f. Sample Containers and Volumes | 28 |
| B.2.g. Sample Preservation | 28 |
| B.2.h. Cleaning/Decontamination of Sampling Equipment | 29 |
| B.2.i Support Facilities | 29 |
| B.2.j. Corrective Action, Personnel, and Documentation | 30 |
| | |
| B.3. Sample Handling and Custody | 30 |
| B.3.a Maximum Hold Time/Time Before Retrieval | 30 |
| B.3.b. Sample Transportation | 30 |
| B.3.c. Sampling Documentation | 30 |
| B.3.d. Sample Identification | 30 |
| B.3.e. Sample Chain-of-Custody | 32 |
| | |
| B.4. Analytical Methods | 32 |
| B.4.a. Analytical SOPs | 32 |
| B.4.c. Method Performance Criteria | 32 |
| B.4.d. Analytical Failure | 32 |
| B.4.e. Sample Disposal | 32 |
| B.4.f Laboratory Turnaround | 32 |
| B.4.g. Method Validation for Nonstandard Methods | 33 |

| | |
|---|-----------|
| B.5. Quality Control | 36 |
| B.5.a. QC activities | 36 |
| Blanks | 36 |
| Duplicates | 36 |
| B.5.b. Exceeding Control Limits | 36 |
| B.5.c. Calculating Applicable QC Statistics | 36 |
| Charge Balance | 36 |
| Mass Balance | 36 |
| Outliers | 37 |
| | |
| B.6. Instrument/Equipment Testing, Inspection, and Maintenance | 37 |
| | |
| B.7. Instrument/Equipment Calibration and Frequency | 37 |
| B.7.a. Calibration and Frequency of Calibration | 37 |
| B.7.b. Calibration Methodology | 37 |
| B.7.c. Calibration Resolution and Documentation | 38 |
| | |
| B.8. Inspection/Acceptance for Supplies and Consumables | 38 |
| B.8.a/b. Supplies, Consumables, and Responsibilities | 38 |
| | |
| B.9. Nondirect Measurements | 38 |
| Seismic Monitoring Methods | 38 |
| B.9.a Data Sources | 38 |
| B.9.b. Relevance to Project | 38 |
| B.9.c. Acceptance Criteria | 38 |
| B.9.d. Resources/Facilities Needed | 39 |
| B.9.e. Validity Limits and Operating Conditions | 39 |
| | |
| B.10. Data Management | 39 |
| B.10.a. Data Management Scheme | 39 |
| B.10.b. Record-keeping and Tracking Practices | 39 |
| B.10.c. Data Handling Equipment/Procedures | 39 |
| B.10.d. Responsibility | 39 |
| B.10.e. Data Archival and Retrieval | 39 |
| B.10.f. Hardware and Software Configurations | 39 |
| B.10.g. Checklists and Forms | 39 |
| | |
| C. ASSESSMENT AND OVERSIGHT | 39 |
| | |
| C.1. Assessments and Response Actions | 39 |
| C.1.a. Activities to be Conducted | 39 |
| C.1.b. Responsibility for Conducting Assessments | 40 |

| | |
|---|-----------|
| C.1.c. Assessment Reporting | 40 |
| C.1.d. Corrective Action | 40 |
| C.2. Reports to Management | 40 |
| C.2.a/b. QA status Reports | 40 |
| D. DATA VALIDATION AND USABILITY | 40 |
| D.1. Data Review, Verification, and Validation | 40 |
| D.1.a. Criteria for Accepting, Rejecting, or Qualifying Data | 40 |
| D.2. Verification and Validation Methods | 41 |
| D.2.a. Data Verification and Validation Processes | 41 |
| D.2.b. Data Verification and Validation Responsibility | 41 |
| D.2.c. Issue Resolution Process and Responsibility | 41 |
| D.2.d. Checklist, Forms, and Calculations | 41 |
| D.3. Reconciliation with User Requirements | 41 |
| D.3.a. Evaluation of Data Uncertainty | 41 |
| D.3.b. Data Limitations Reporting | 41 |
| REFERENCES | 42 |
| APPENDICES | 44 |
| APPENDIX A. DTS and Down-hole Pressure Gauge Information | 44 |
| APPENDIX B. Log Quality Control Reference Manual (LQCRM) | 49 |

List of Tables

| | |
|--|----|
| TABLE 1. SUMMARY OF TESTING AND MONITORING. | 4 |
| TABLE 2. INSTRUMENTATION SUMMARY. T = TEMPERATURE; P = PRESSURE; DTS = DISTRIBUTED TEMPERATURE SYSTEM; F = FLOW (CONTINUED ON PAGE 9). | 8 |
| TABLE 3. GEOPHYSICAL SURVEYS SUMMARY. | 10 |
| TABLE 4. SUMMARY OF ANALYTICAL AND FIELD PARAMETERS FOR QUATERNARY/PENNSYLVANIAN GROUNDWATER SAMPLES. | 14 |
| TABLE 5. SUMMARY OF ANALYTICAL AND FIELD PARAMETERS FOR ST PETER RESERVOIR GROUNDWATER SAMPLES. | 15 |
| TABLE 6. SUMMARY OF ANALYTICAL AND FIELD PARAMETERS FOR IRONTON-GALESVILLE GROUNDWATER SAMPLES. | 16 |
| TABLE 7. SUMMARY OF ANALYTICAL AND FIELD PARAMETERS FOR MT SIMON GROUNDWATER SAMPLES. | 17 |
| TABLE 8. SUMMARY OF ANALYTICAL PARAMETERS FOR CO ₂ GAS STREAM. | 18 |
| TABLE 6. SUMMARY OF ANALYTICAL PARAMETERS FOR CORROSION COUPONS. | 19 |
| TABLE 7. SUMMARY OF MEASUREMENT PARAMETERS FOR FIELD GAUGES. | 19 |
| TABLE 8. ACTIONABLE TESTING AND MONITORING OUTPUTS. | 20 |
| TABLE 12. PRESSURE AND TEMPERATURE—DOWNHOLE QUARTZ GAUGE SPECIFICATIONS. | 21 |
| TABLE 10. LOGGING TOOL SPECIFICATIONS. | 21 |
| TABLE 11. PRESSURE FIELD GAUGE PIT-009—INJECTION TUBING PRESSURE. | 22 |
| TABLE 12. PRESSURE FIELD GAUGE PIT-014—ANNULS PRESSURE. | 22 |
| TABLE 13. PRESSURE FIELD GAUGE PIT-012. | 22 |
| TABLE 14. TEMPERTATURE FIELD GAUGE TIT-019 —INJECTION TUBING TEMPERATURE. | 22 |
| TABLE 15. MASS FLOW RATE FIELD GAUGE—FT-006 CO ₂ MASS FLOW RATE. | 22 |
| TABLE 16. WESTBAY FIELD GAUGE—WESTBAY (MOSDAX) PRESSURE. | 22 |
| TABLE 17. STABILIZATION CRITERIA OF WATER QUALITY PARAMETERS DURING SHALLOW WELL PURGING. | 27 |
| TABLE 18. SUMMARY OF SAMPLE CONTAINERS, PRESERVATION TREATMENTS, AND HOLDING TIMES FOR CO ₂ GAS STREAM ANALYSIS. | 29 |
| TABLE 19. SUMMARY OF ANTICIPATED SAMPLE CONTAINERS, PRESERVATION TREATMENTS, AND HOLDING TIMES. | 31 |
| TABLE 20. EXAMPLE TABLE OF CRITERIA USED TO EVALUATE DATA QUALITY. | 41 |

List of Figures

| | |
|--|----|
| FIGURE 1. ARCHER DANIELS MIDLAND COMPANY KEY PROJECT PERSONNEL. | 2 |
| FIGURE 4. IL-ICCS PROJECT AREA SHOWING LOCATION OF EXISTING SHALLOW GROUNDWATER MONITORING WELLS AND PLANNED DEEP WELLS. | 11 |
| FIGURE 5. EXAMPLE LABEL FOR GROUNDWATER SAMPLE BOTTLES. | 32 |
| FIGURE 6. EXAMPLE OF CO ₂ GAS STREAM ANALYSIS AUTHORIZATION FORM. | 34 |
| FIGURE 7. EXAMPLE CHAIN-OF-CUSTODY FORM. | 35 |

Distribution List

The following project participants should receive the completed Quality Assurance and Surveillance Plan (QASP) and all future updates for the duration of the project. The ADM Corn Plant Manager will be responsible for ensuring that all those on the distribution list will receive the most current copy of the approved Quality Assurance and Surveillance Plan. Names in bold are the primary points of contact with addresses listed below.

ADM

Steve Merritt

Dean Frommelt

Ed Taylor

Mark Atkinson

Archer Daniels Midland Company – Corn Processing
Facilities Contact : Mr. Steve Merritt, Corn Plant Manager
Mailing Address : 4666 Faries Parkway
Decatur, IL 62526
Phone : 217-424-5750

A. Project Management

A.1. Project/Task Organization

A.1.a/b. Key Individuals and Responsibilities

The project, led by Archer Daniels Midland Company (ADM), includes participation from several subcontractors. The Testing and Monitoring Activities responsibilities will be shared between ADM and their designated subcontractor and the program will be broken in six subcategories:

- I) Shallow Groundwater Sampling
- II) Deep Groundwater Sampling
- III) Well Logging
- IV) Mechanical Integrity Testing (MIT)
- V) Pressure/Temperature Monitoring
- VI) CO₂ Stream Analysis
- VII) Geophysical Monitoring

A.1.c. Independence from Project QA Manager and Data Gathering

The majority of the physical samples collected and data gathered as part of the MVA program is analyzed, processed, or witnessed by third parties independent and outside of the project management structure.

A.1.d. QA Project Plan Responsibility

ADM will be responsible for maintaining and distributing official, approved QA Project Plan. ADM will periodically review this QASP and consult with USEPA if/when changes to the plan are warranted.

A.1.e. Organizational Chart for Key Project Personnel

Figures 1 shows the organization structure of the project. ADM will provide to the UIC Program Director a contact list of individuals fulfilling these roles.

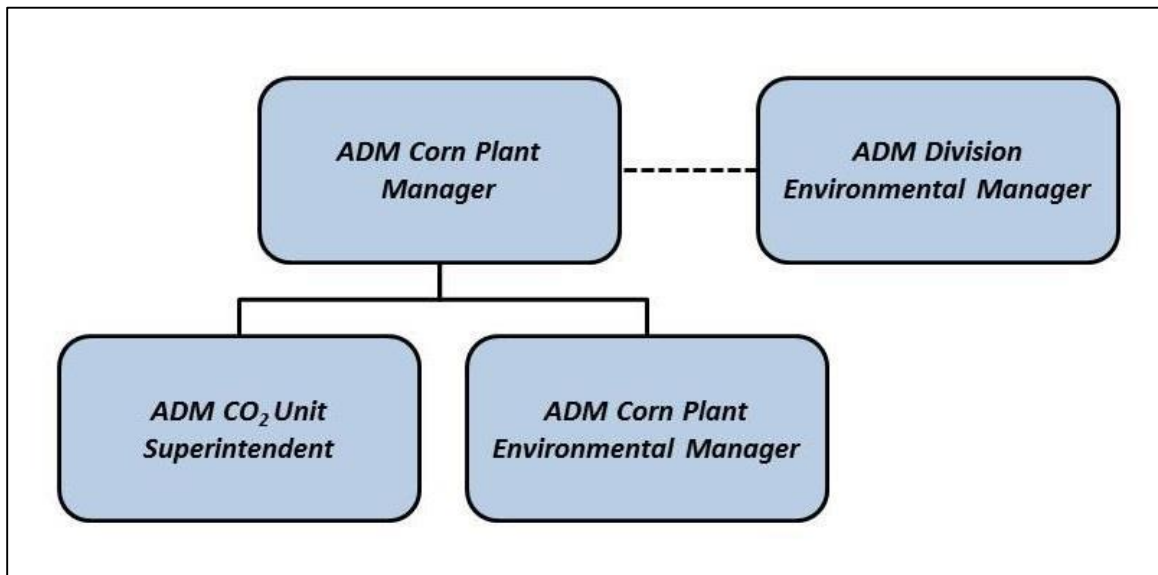

Figure 1. Archer Daniels Midland Company project organization structure.

A.2. Problem Definition/Background

A.2.a Reasoning

The Illinois Industrial Carbon Capture and Storage (IL-ICCS) Project’s monitoring, verification, and accounting (MVA) program has operational monitoring, verification, and environmental monitoring components. Operational monitoring is used to ensure safety with all procedures associated with fluid injection, monitor the response of storage unit, and the movement of the CO₂ plume. Key monitoring parameters include the pressure of injection well tubing & annulus, storage unit, above seal strata, and the lowermost USDW reservoir. Other monitoring parameters include injection rate, total mass & volume injected, injection well temperature profile, and passive seismic. The verification component will provide information to evaluate if leakage of CO₂ through the caprock is occurring. This includes pulse neutron logging, pressure, and temperature monitoring. The environmental monitoring components will determine if the injectate is being released into the shallow subsurface or biosphere. This monitoring includes pulse neutron logging and ground water monitoring.

A robust MVA program has been developed for the IL-ICCS project based on the experience gained through the Illinois Basin–Decatur Project (IBDP). The knowledge and experience gained through the IBDP provides a high level of confidence that the storage unit (Mt Simon) is capable to accept and permanently retain the injectate. The primary goal of the IL-ICCS MVA program is to demonstrate that project activities are protective of human health and the environment. To help achieve this goal, this Quality Assurance Surveillance Plan (QASP) was developed to insure the quality standards of the testing and monitoring program meet the requirements of the U.S. Environmental Protection Agency’s (USEPA) Underground Injection Control (UIC) Program for Class VI wells.

A.2.b. Reasons for Initiating the Project

The goal of the IL-ICCS injection project is to demonstrate the ability of the Mt. Simon Sandstone to accept and retain industrial-scale volumes of CO₂ for permanent geologic sequestration to reduce atmospheric concentrations of CO₂. In order to demonstrate that this can be done safely and at commercial scale, a rigorous MVA plan is proposed to ensure the injected CO₂ is retained within the intended storage reservoir.

A.2.c. Regulatory Information, Applicable Criteria, Action Limits

The Class VI Rule requires owners or operators of Class VI wells to perform several types of activities during the lifetime of the project in order to ensure that the injection well maintains its mechanical integrity, that fluid migration and the extent of pressure elevation are within the limits described in the permit application, and that underground sources of drinking water (USDWs) are not endangered. These monitoring activities include mechanical integrity tests (MITs), injection well testing during operation, monitoring of ground water quality in several zones, tracking of the CO₂ plume and associated pressure front. This document details both the measurements that will be taken as well as the steps to ensure that the quality of all the data is such that the data can be used with confidence in making decisions during the life of the project.

A.3. Project/Task Description

A.3.a/b. Summary of Work to be Performed and Work Schedule

Table 1 describes the Testing and Monitoring tasks, reasoning, responsible parties, locations and testing frequency. Tables 2 and 3 summarize the instrumentation and geophysical surveys, respectively.

Table 1. Summary of testing and monitoring.

| Parameter | Location | Method | Frequency | | | Analytical Technique | Lab/Custody | Purpose |
|--------------------------------|---|---------------------------------------|--|--|--|--|-------------|---|
| | | | Pre-injection— Baseline | Operation Period — 5 years | PISC Period—10 years | | | |
| Carbon dioxide stream analysis | Compressor After CO ₂ dehydration | Direct sampling Direct sampling | 2 years: Quarterly 2 years: Quarterly | Quarterly Quarterly | None None | Chemical analysis Chemical analysis | TBD TBD | Monitor injectate Monitor injectate |
| Continuous recording | | | | | | | | |
| Injection rate and volume | After compression CCS2 Wellhead | Flow meter Pressure gauge | N/A N/A | Continuous Continuous | N/A N/A | Direct measurement Direct measurement | N/A N/A | Monitor rate and volume Monitor injection pressure |
| Annular pressure | CCS2 Wellhead | Pressure gauge | N/A | Continuous | N/A | Direct measurement | N/A | Monitor annular pressure |
| DTS Fiber Optic Temperature | CCS2 Wellbore | Fiber optic cable | N/A | Continuous | Yr 1- Continuous Yr 2-10 - N/A | Direct measurement | N/A | Wellbore integrity |
| Downhole pressure/temperature | CCS2: Mt Simon | Downhole gauge | N/A | Continuous | Yr 1-3 Continuous Yr 4-10 – Annual | Direct measurement | N/A | Monitor reservoir |
| Corrosion monitoring | After compression | Coupon | N/A | Quarterly | N/A | Chemical analysis | TBD | Monitor injectate, wellbore integrity |
| Mechanical Integrity | CCS2 | Various | Prior to operation | Annually | Prior to P/A | \$ 146.87 (a)(4) \$ 146.89 (c)(2) | N/A | Wellbore integrity |
| DTS Fiber Optic | CCS2 | Fiber optic cable | Continuous | Continuous | Yr 1 Continuous Yr 2-10 – N/A | Direct measurement | N/A | Wellbore integrity |
| Cement evaluation | CCS2 | Logging | Baseline | N/A | N/A | Cement evaluation log | N/A | Wellbore integrity |
| Pressure fall off testing | CCS2: Mt. Simon | Pressure gauge | N/A | During injection- approximately half way through the injection phase and at the end of the injection period. | N/A | Direct measurement | N/A | Wellbore integrity |
| Microseismic | Various monitoring stations | Multilevel geophones and seismometers | Continuous | Continuous | Continuous | Direct measurement | N/A | Reservoir integrity |

Table 1. Summary of testing and monitoring (continued).

| Direct Geochemical Measurement Level | Location Depth | Method | Frequency | | | Analytical Technique | Parameters | Purposes |
|--|----------------|----------------------------|------------------------|--|----------------------|----------------------|------------|---|
| | | | Pre-injection—Baseline | Operation Period—5 years | PISC Period—10 years | | | |
| Shallow groundwater (Quaternary & Pennsylvanian) | Figure 2 | In-situ | 2 years: Quarterly | Year 1-2: Quarterly Year 3-5: Bi-annually | Annually | Chemical analysis | Table 4 | Detection of changes in groundwater quality for a shallow USDW. |
| Lowermost USDW (St. Peter) | GM2 | Swab valve or other method | 1 sample | Annually | Annually | Chemical analysis | Table 5 | Detection of changes in groundwater quality in lowermost USDW. |
| Above confining zone (Iron-ton-Galesville) | VW1 | In-situ | 1 sample | Baseline; Year 1-3: Annual Year 4-5: N/A | None | Chemical analysis | Table 6 | Detection of changes in groundwater quality for reservoir directly above the confining zone. |
| | VW2 | In-situ | 1 sample | Annually | Annually | Chemical analysis | Table 6 | Detection of changes in groundwater quality for reservoir directly above the confining zone. |
| In-zone monitoring (Mt. Simon) | VW1 | In-situ | 1 sample | Baseline; Year 1-3: Annual Year 4-5: N/A | None | Chemical analysis | Table 7 | Detection of changes in groundwater quality, geochemical monitoring and CO ₂ detection in storage reservoir. |
| | VW2 | In-situ | 1 sample | Annually | Annually | Chemical analysis | Table 7 | Detection of changes in groundwater quality, geochemical monitoring and CO ₂ detection in storage reservoir. |

* Samples collected using downhole sampling tool run into well on wireline.

* Swab samples collected at surface after well has been swabbed with ample volume to ensure reservoir fluid at surface.

Table 1. Summary of testing and monitoring (continued).

| Indirect Methods of CO ₂ Plume Tracking | | | | | | |
|--|----------------|----------------------------|--------------------------|----------------------|------------------------------------|--|
| Method | Location | Pre-injection— Baseline | Operation Period—5 years | PISC Period—10 Years | Purpose | |
| Time lapse VSP | GM1 | 2013, 2014, 2015 | None | None | Indirect measurement of plume size | |
| Time lapse 3D | Injection area | Baseline survey | Year 2 (2019) | Year 1 and Year 10 | Indirect measurement of plume size | |

Table 2. Instrumentation summary. T = Temperature; P = Pressure; DTS = Distributed Temperature System; F = Flow.

| Monitoring Location | Instrument Type | Monitoring Target (Formation or Other) | Operational Period—5 Years | | PISC Period—10 Years | | Explanation |
|--------------------------|-----------------|--|--|--|--|---------------------------------------|--|
| | | | Data Collection Location(s) | Frequency | Data Collection Location(s) | Frequency | |
| CO ₂ Facility | T, P, F | Surface | Discharge High Pressure Pumps | Continuous | Discharge high pressure pumps | NA | Monitoring the operational, equipment, and permit parameters |
| | DTS | All strata | Distributed measurement to 6325 KB/5631 MSL. | Continuous | Distributed measurement to 6325 KB/5631 MSL. | Yr 1-3: Continuous Yr 2-10: None | Monitoring operational parameters and well integrity |
| | T, P | Mt. Simon | 1 interval PT @ 6325 KB/5631 MSL Perfs @ 6982-7050 KB 6288-6356 MSL | Continuous 1 interval | 1 interval PT @ 6325 KB/5631 MSL Perfs @ 6982-7050 KB 6288-6356 MSL | Yr 1-3: Continuous Yr 4-10: Annual | Monitoring operational and equipment parameters |
| CCS#1 | Geophones | All strata | 3 interval array | Note 1. | 3 intervals | Note 1. | Note 1: Operator will maintain a passive seismic monitoring system that has the ability to detect seismic events over M1.0 within the AOR. |
| | T, P | Surface well head | Tubing | Continuous | Tubing | Continuous | Monitoring operational, equipment, and permit parameters |
| | P | | Annulus | Continuous | Annulus | Continuous | Monitoring well integrity |
| | DTS | All geologic strata | Distributed measurement to 6211 KB/5520 MSL. 1 point location, 1 interval: PT @ 6270 KB/5579 MSL; Perfs @ 6630 - 6825 KB, 5939 - 6134 MSL | Continuous | Distributed measurement to 6211 KB/5520 MSL. | Yr 1: Continuous Yr 2-10: None | Monitoring operational parameters and well integrity |
| | T, P | Mt. Simon | 1 interval PT @ 6270 KB/5579 MSL; Perfs @ 6630 - 6825 KB, 5939 - 6134 MSL | Continuous | 1 point location, 1 interval: PT @ 6270 KB/5579 MSL; Perfs @ 6630 - 6825 KB, 5939 - 6134 MSL | Yr 1-3: Continuous Yr 4-10: Annual | Monitoring operational, equipment, and permit parameters |
| VW1 | T, P | Ironton-Galesville | 1 interval 4918-5000 KB 4224-4306 MSL | Year 1-3: Continuous Year 4-5: None | 1 interval 4918-5000 KB 4224-4306 MSL | None | Monitoring seal formation integrity |
| | | Mt. Simon | 1 interval 6945-5654 KB 6251-4960 MSL | Year 1-3: Continuous Year 4-5: None | 1 interval 6945-5654 KB 6251-4960 MSL | None | Monitoring plume pressure and temperature front |

Table 2. Instrumentation summary. T = Temperature; P = Pressure; DTS = Distributed Temperature System; F = Flow (continued).

| Monitoring Location | Instrument Type | Monitoring Target (Formation or Other) | Operational Period—5 Years | | PISC Period—10 Years | | Explanation |
|-------------------------|--------------------------|--|--|---------------------|--|---------------------------------------|--|
| | | | Data Collection Location(s) | Frequency | Data Collection Location(s) | Frequency | |
| VW2 | T, P | Ironton-Galesville | 1 point location, 1 interval: 4902 KB/4199 MSL | Baseline Continuous | 1 point location, 1 interval: 4902 KB/4199 MSL | Yr 1–3: Continuous Yr 4–10: Annual | Monitoring seal formation integrity |
| | T, P | Mt. Simon | 1 point location, 4 intervals: 7041, 6681, 6524, 5848 KB; 6338, 5978, 5821, 5145 MSL | Continuous | 1 point location, 4 intervals: 7041, 6681, 6524, 5848 KB; 6338, 5978, 5821, 5145 MSL | Continuous | Monitoring plume pressure and temperature front |
| GM1 | Geophones | All strata | 20 interval array | Note 1. | 20 interval array | Note 1. | Note 1: Operator will maintain a passive seismic monitoring system that has the ability to detect seismic events over M1.0 within the AoR. |
| GM2 | T, P | St. Peter | 1 point location, 1 interval: 3450 KB/2759 MSL | Continuous | 1 point location, 1 interval: 3450 KB/2759 MSL | Yr 1–3: Continuous Yr 4–10: Annual | Monitoring seal formation integrity |
| | Geophones | All strata | 5 interval array | Note 1. | 5 interval array | Note 1. | Note 1: Operator will maintain a passive seismic monitoring system that has the ability to detect seismic events over M1.0 within the AoR. |
| Seismic Stations | Seismometers & geophones | All strata | Combination of surface and borehole monitoring stations | Note 1. | Various | Note 1. | Note 1: Operator will maintain a passive seismic monitoring system that has the ability to detect seismic events over M1.0 within the AoR. |

Table 3. Geophysical surveys summary.

| Monitoring Activity | Well | Tools or Survey Description | Pre-Injection - Baseline | Operation Period - 5 Years | PISC Period - 10 Years | Explanation |
|---------------------|-------|-----------------------------|--------------------------|----------------------------|------------------------|---|
| Logging | GM#1 | CBL | 1 Baseline | None | None | Mechanical Integrity |
| | GM#2 | CBL | 1 Baseline | None | None | Mechanical Integrity |
| | VW#1 | Cement evaluation tool | 1 Baseline | None | None | Mechanical Integrity |
| | | Pulse neutron | 1 Baseline | Year 2, 4 | Year 1, 3, 5, 7, 10 | Fluid movement, salinity, CO ₂ detection, mechanical integrity |
| | VW#2 | Cement evaluation tool | 1 Baseline | None | None | Mechanical Integrity |
| | | Pulse neutron | 1 Baseline | Year 2, 4 | Year 1, 3, 5, 7, 10 | Fluid movement, salinity, CO ₂ detection, mechanical integrity |
| | CCS#1 | Pulse neutron | 1 Baseline | Year 2, 4 | Year 1, 3, 5, 7, 10 | Fluid movement, salinity, CO ₂ detection, mechanical integrity |
| | | Casing inspection | 1 Baseline | None | None | Mechanical Integrity |
| | | Cement evaluation tool | 1 Baseline | None | None | Mechanical Integrity |
| | CCS#2 | Pulse neutron | 1 Baseline | Year 2, 4 | Year 1, 3, 5, 7, 10 | Fluid movement, salinity, CO ₂ detection, mechanical integrity |
| | | Casing inspection | 1 Baseline | None | None | Mechanical Integrity |
| | | Cement evaluation tool | 1 Baseline | None | None | Mechanical Integrity |
| Seismic | GM#1 | Time-lapse VSP survey | 2013, 2014, 2015 | None | None | Monitor spatial extent of plume |
| | Area | 3D surface seismic survey | 1 Baseline | Year 2 (2019) | Year 1, Year 10 | Monitor spatial extent of plume |

A.3.c. Geographic Locations

Figure 2 shows the IL-ICCS site and monitoring infrastructure.

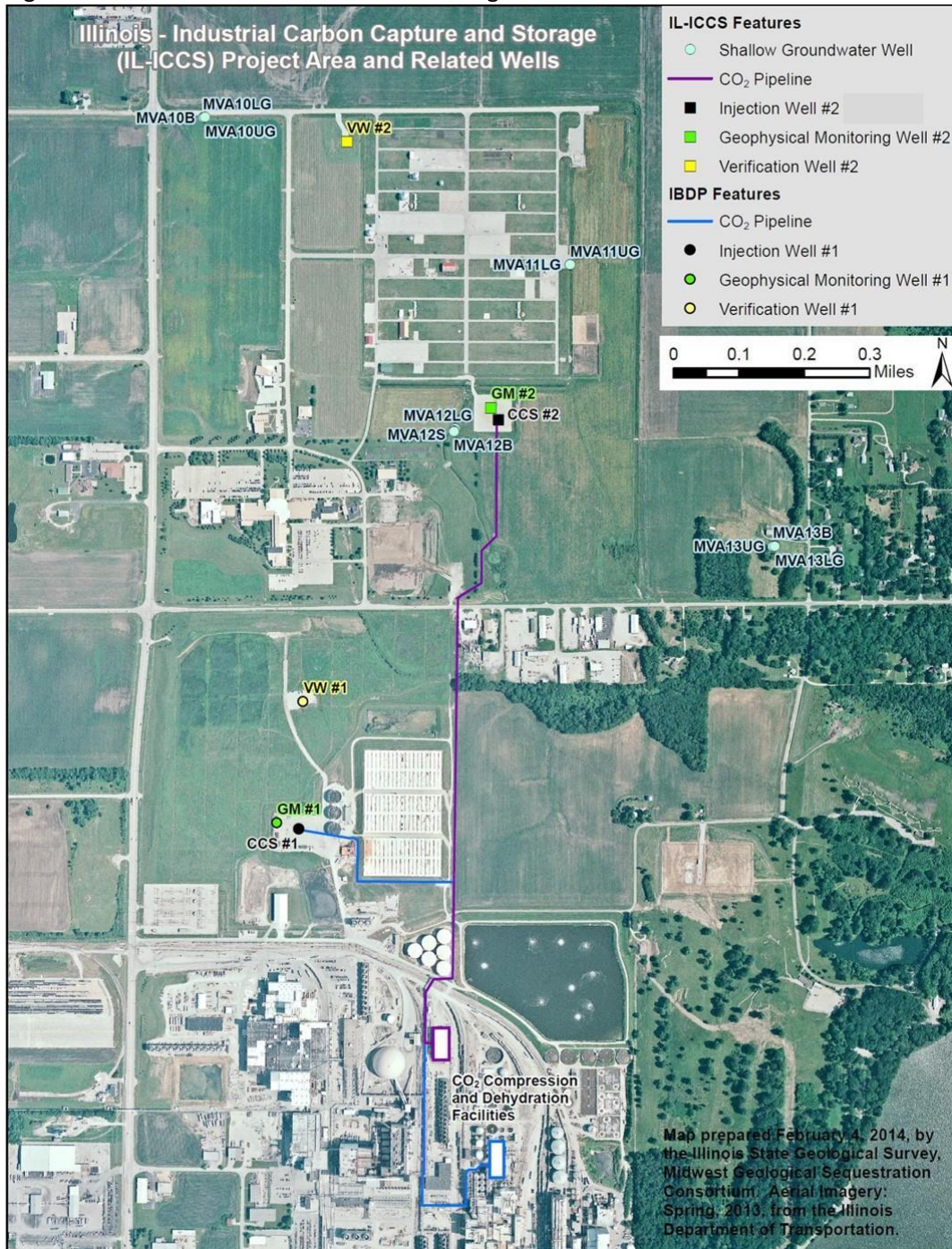

Figure 2. IL-ICCS Project area showing location of shallow groundwater monitoring wells and deep monitoring wells.

A.3.d. Resource and Time Constraints

At the conclusion of the IBDP project, the availability of wells associated with that project (VW#1, GM#1, CCS#1) are potential resource constraints for IL-ICCS. Under its current state-issued UIC permit, IBDP post-injection monitoring will continue for at least 2 to 3 years after injection ceases in November 2014. Thereafter, the status and availability of the IBDP wells for use by the IL-ICCS project is uncertain. No additional resource or time constraints have been identified for the IL-ICCS testing and monitoring plan beyond project funding levels and the proposed timeline.

A.4. Quality Objectives and Criteria

A.4.a. Performance/Measurement Criteria

The overall QA objective for monitoring is to develop and implement procedures for subsurface monitoring, field sampling, laboratory analysis, and reporting which will provide results that will meet the characterization and non-endangerment goals of this project. Groundwater monitoring will be conducted during the pre-injection, injection, and post-injection phases of the project. Shallow and deep groundwater monitoring wells will be used to gather water-quality samples and pressure data. All the groundwater analytical and field monitoring parameters for each interval are listed in Table 4 through Table 7. Table 8, Table 9 and Table 10 show analytical parameters for CO₂ stream gas monitoring, corrosion coupon assessment, and gauge specifications. Table 11 shows the monitoring outputs. The list of analytes may be reassessed periodically and adjusted to include or exclude analytes based on their effectiveness to the overall monitoring program goals.

Key testing and monitoring areas include:

- I. Shallow Groundwater Sampling
 - Aqueous chemical concentrations
- II. Deep Formation Fluid Sampling
 - Aqueous chemical concentrations
- III. Well Logging
 - pulse neutron
- IV. Mechanical Integrity Testing (MIT)
 - Pulsed neutron, temperature, cement evaluation logging
- V. Pressure/Temperature Monitoring
 - Pressure/temperature from in-situ gauges
 - Pressure/temperature from surface gauges
- VI. CO₂ Stream Analysis
 - CO₂ Purity (% v/v, [GC])
 - Oxygen (O₂, ppm v/v)
 - Nitrogen (N₂, ppm v/v)
 - Carbon Monoxide (CO, ppm v/v)
 - Oxides of Nitrogen (NO_x, ppm v/v)
 - Total Hydrocarbons (THC, ppm v/v as CH₄)

- Methane (CH₄, ppm v/v)
- Acetaldehyde (AA, ppm v/v)
- Sulfur Dioxide (SO₂, ppm v/v)
- Hydrogen Sulfide (H₂S ppm v/v)
- Ethanol (ppm v/v)

VII. Geophysical Monitoring

- Seismic data files (e.g., segd file)
- Processed time-lapse report

Table 4. Summary of analytical and field parameters for Quaternary/Pennsylvanian groundwater samples. All analysis will all be performed by ADM or a designated third party laboratory.

ICP = inductively coupled plasma; MS = mass spectrometry; OES = optical emission spectrometry; GC-P = gas chromatography - pyrolysis.

| Parameters | Analytical Methods⁽¹⁾ | Detection Limit/Range | Typical Precisions | QC Requirements |
|--|---|---|---------------------------|---|
| Cations: Al, Ba, Mn, As, Cd, Cr, Cu, Pb, Sb, Se, and Tl | ICP-MS, EPA Method 6020 | 0.001 to 0.1 mg/L (analyte, dilution and matrix dependent) | ±15% | Daily calibration; blanks, duplicates and matrix spikes at 10% or greater frequency |
| Cations: Ca, Fe, K, Mg, Na, and Si | ICP-OES, EPA Method 6010B | 0.005 to 0.5 mg/L (analyte, dilution and matrix dependent) | ±15% | Daily calibration; blanks, duplicates and matrix spikes at 10% or greater frequency |
| Anions: Br, Cl, F, NO ₃ , and SO ₄ | Ion Chromatography, EPA Method 300.0 | 0.02 to 0.13 mg/L (analyte, dilution and matrix dependent) | ±15% | Daily calibration; blanks and duplicates at 10% or greater frequency |
| Dissolved CO ₂ | Coulometric titration, ASTM D513-11 | 25 mg/L | ±15% | Duplicate measurement; standards at 10% or greater frequency |
| Total Dissolved Solids | Gravimetry; APHA 2540C | 12 mg/L | ±10% | Balance calibration, duplicate analysis |
| Alkalinity | APHA 2320B | 4 mg/L | ±3 mg/L | Duplicate analysis |
| pH (field) | EPA 150.1 | 2 to 12 pH units | ±0.2 pH unit | User calibration per manufacturer recommendation |
| Specific conductance (field) | APHA 2510 | 0 to 200 mS/cm | ±1% of reading | User calibration per manufacturer recommendation |
| Temperature (field) | Thermocouple | -5 to 50°C | ±0.2°C | Factory calibration |

Note 1: An equivalent method may be employed with the prior approval of the UIC Program Director.

Table 5. Summary of analytical and field parameters for St Peter Reservoir groundwater samples. All analysis will be performed by ADM or a designated third party laboratory. ICP = inductively coupled plasma; MS = mass spectrometry; OES = optical emission spectrometry; GC-P = gas chromatography - pyrolysis.

| Parameters | Analytical Methods⁽¹⁾ | Detection Limit/Range | Typical Precisions | QC Requirements |
|--|--|---|------------------------------|---|
| Cations: Al, Ba, Mn, As, Cd, Cr, Cu, Pb, Sb Se, and Tl | ICP-MS, EPA Method 6020 | 0.001 to 0.1 mg/L (analyte, dilution and matrix dependent) | ±15% | Daily calibration; blanks, duplicates and matrix spikes at 10% or greater frequency |
| Cations: Ca, Fe, K, Mg, Na, and Si | ICP-OES, EPA Method 6010B | 0.005 to 0.5 mg/L (analyte, dilution and matrix dependent) | ±15% | Daily calibration; blanks, duplicates and matrix spikes at 10% or greater frequency |
| Anions: Br, Cl, F, NO ₃ , and SO ₄ | Ion Chromatography, EPA Method 300.0 | 0.02 to 0.13 mg/L (analyte, dilution and matrix dependent) | ±15% | Daily calibration; blanks and duplicates at 10% or greater frequency |
| Dissolved CO ₂ | Coulometric titration, ASTM D513-11 | 25 mg/L | ±15% | Duplicate measurement; standards at 10% or greater frequency |
| Isotopes: δ ¹³ C of DIC | Isotope ratio mass spectrometry ² | 12.2 mg/L HCO ₃ ⁻ for δ ¹³ C | ±0.15‰ for δ ¹³ C | 10% duplicates; 4 standards/batch |
| Total Dissolved Solids | Gravimetry; APHA 2540C | 12 mg/L | ±10% | Balance calibration, duplicate analysis |
| Water Density(field) | Oscillating body method | 0.0000 to 2.0000 | ±0.0002 g/mL | Duplicate measurements |
| Alkalinity | APHA 2320B | 4 mg/L | ±3 mg/L | Duplicate analysis |
| pH (field) | EPA 150.1 | 2 to 12 pH units | ±0.2 pH unit | User calibration per manufacturer recommendation |
| Specific conductance (field) | APHA 2510 | 0 to 200 mS/cm | ±1% of reading | User calibration per manufacturer recommendation |
| Temperature (field) | Thermocouple | -5 to 50°C | ±0.2°C | Factory calibration |

Note 1: An equivalent method may be employed with the prior approval of the UIC Program Director.

Note 2: Gas evolution technique by Atekwana and Krishnamurthy (1998), with modifications made by Hackley et al. (2007)

Table 6. Summary of analytical and field parameters for Ironton-Galesville groundwater samples. Note: Cation, anion, TDS, and alkalinity measurements will all be performed by a laboratory meeting the requirements under the USEPA Environmental Laboratory Accreditation Program. Isotope and dissolved CO₂ analyses will be performed by ADM or a designated laboratory. ICP = inductively coupled plasma; MS = mass spectrometry; OES = optical emission spectrometry; GC-P = gas chromatography - pyrolysis.

| Parameters | Analytical Methods⁽¹⁾ | Detection Limit/Range | Typical Precisions | QC Requirements |
|--|--|---|------------------------------|---|
| Cations: Al, Ba, Mn, As, Cd, Cr, Cu, Pb, Sb, Se, and Tl | ICP-MS, EPA Method 6020 | 0.001 to 0.1 mg/L (analyte, dilution and matrix dependent) | ±15% | Daily calibration; blanks, duplicates and matrix spikes at 10% or greater frequency |
| Cations: Ca, Fe, K, Mg, Na, and Si | ICP-OES, EPA Method 6010B | 0.005 to 0.5 mg/L (analyte, dilution and matrix dependent) | ±15% | Daily calibration; blanks, duplicates and matrix spikes at 10% or greater frequency |
| Anions: Br, Cl, F, NO ₃ , and SO ₄ | Ion Chromatography, EPA Method 300.0 | 0.02 to 0.13 mg/L (analyte, dilution and matrix dependent) | ±15% | Daily calibration; blanks and duplicates at 10% or greater frequency |
| Dissolved CO ₂ | Coulometric titration, ASTM D513-11 | 25 mg/L | ±15% | Duplicate measurement; standards at 10% or greater frequency |
| Isotopes: δ ¹³ C of DIC | Isotope ratio mass spectrometry ² | 12.2 mg/L HCO ₃ ⁻ for δ ¹³ C | ±0.15‰ for δ ¹³ C | 10% duplicates; 4 standards/batch |
| Total Dissolved Solids | Gravimetry; APHA 2540C | 12 mg/L | ±10% | Balance calibration, duplicate analysis |
| Water Density(field) | Oscillating body method | 0.0000 to 2.0000 | ±0.0002 g/mL | Duplicate measurements |
| Alkalinity | APHA 2320B | 4 mg/L | ±3 mg/L | Duplicate analysis |
| pH (field) | EPA 150.1 | 2 to 12 pH units | ±0.2 pH unit | User calibration per manufacturer recommendation |
| Specific conductance (field) | APHA 2510 | 0 to 200 mS/cm | ±1% of reading | User calibration per manufacturer recommendation |
| Temperature (field) | Thermocouple | -5 to 50°C | ±0.2°C | Factory calibration |

Note 1: An equivalent method may be employed with the prior approval of the UIC Program Director.

Note 2: Gas evolution technique by Atekwana and Krishnamurthy (1998), with modifications made by Hackley et al. (2007)

Table 7. Summary of analytical and field parameters for Mt Simon groundwater samples. All analysis will be performed by ADM or a designated third party laboratory. ICP = inductively coupled plasma; MS = mass spectrometry; OES = optical emission spectrometry; GC-P = gas chromatography - pyrolysis.

| Parameters | Analytical Methods⁽¹⁾ | Detection Limit/Range | Typical Precisions | QC Requirements |
|--|--|---|------------------------------|---|
| Cations: Al, Ba, Mn, As, Cd, Cr, Cu, Pb, Sb, Se, and Tl | ICP-MS, EPA Method 6020 | 0.001 to 0.1 mg/L (analyte, dilution and matrix dependent) | ±15% | Daily calibration; blanks, duplicates and matrix spikes at 10% or greater frequency |
| Cations: Ca, Fe, K, Mg, Na, and Si | ICP-OES, EPA Method 6010B | 0.005 to 0.5 mg/L (analyte, dilution and matrix dependent) | ±15% | Daily calibration; blanks, duplicates and matrix spikes at 10% or greater frequency |
| Anions: Br, Cl, F, NO ₃ , and SO ₄ | Ion Chromatography, EPA Method 300.0 | 0.02 to 0.13 mg/L (analyte, dilution and matrix dependent) | ±15% | Daily calibration; blanks and duplicates at 10% or greater frequency |
| Dissolved CO ₂ | Coulometric titration, ASTM D513-11 | 25 mg/L | ±15% | Duplicate measurement; standards at 10% or greater frequency |
| Isotopes: δ ¹³ C of DIC | Isotope ratio mass spectrometry ² | 12.2 mg/L HCO ₃ ⁻ for δ ¹³ C | ±0.15‰ for δ ¹³ C | 10% duplicates; 4 standards/batch |
| Total Dissolved Solids | Gravimetry; APHA 2540C | 12 mg/L | ±10% | Balance calibration, duplicate analysis |
| Water Density(field) | Oscillating body method | 0.0000 to 2.0000 | ±0.0002 g/mL | Duplicate measurements |
| Alkalinity | APHA 2320B | 4 mg/L | ±3 mg/L | Duplicate analysis |
| pH (field) | EPA 150.1 | 2 to 12 pH units | ±0.2 pH unit | User calibration per manufacturer recommendation |
| Specific conductance (field) | APHA 2510 | 0 to 200 mS/cm | ±1% of reading | User calibration per manufacturer recommendation |
| Temperature (field) | Thermocouple | -5 to 50°C | ±0.2°C | Factory calibration |

Note 1: An equivalent method may be employed with the prior approval of the UIC Program Director.

Note 2: Gas evolution technique by Atekwana and Krishnamurthy (1998), with modifications made by Hackley et al. (2007)

Table 8. Summary of analytical parameters for CO₂ gas stream. All analysis will be performed by ADM or a designated third party laboratory.

| Parameters | Analytical Methods⁽¹⁾ | Detection Limit/Range | Typical Precisions | QC Requirements |
|------------------------------|--|--|--|--|
| Oxygen | ISBT 4.0 (GC/DID) | 1 uL/L to 5,000 uL/L (ppm by volume) | ± 10 % of reading | daily standard within 10 % of calibration, secondary standard after calibration |
| | GC/TCD | 0.1 % to 100 % | 5 - 10 % relative across the range, RT ± 0.1 min | daily standard, duplicate analysis within 10 % of each other |
| Nitrogen | ISBT 4.0 GC/DID | 1 uL/L to 5,000 uL/L (ppm by volume) | ± 10 % of reading | daily standard within 10 % of calibration, secondary standard after calibration |
| | GC/TCD | 0.1 % to 100 % | 5 - 10 % relative across the range, RT ± 0.1 min | daily standard, duplicate analysis within 10 % of each other |
| Carbon Monoxide | ISBT 5.0 Colorimetric | 5 uL/L to 100 uL/L (ppm by volume) | ± 20 % of reading | duplicate analysis |
| | ISBT 4.0 (GC/DID) | 1 uL/L to 5,000 uL/L (ppm by volume) | ± 10 % of reading | daily standard within 10 % of calibration, secondary standard after calibration |
| Oxides of Nitrogen | ISBT 7.0 Colorimetric | 0.2 uL/L to 5 uL/L (ppm by volume) | ± 20 % of reading | duplicate analysis |
| Total Hydrocarbons | ISBT 10.0 THA (FID) | 1 uL/L to 10,000 uL/L (ppm by volume) | 5 - 10 % of reading relative across the range | daily blank, daily standard within 10 % of calibration, secondary standard after calibration |
| Methane | ISBT 10.1 GC/FID) | 0.1 uL/L to 1,000 uL/L (ppm by volume)-dilution dependent | 5 - 10 % of reading relative across the range | daily blank, daily standard within 10 % of calibration, secondary standard after calibration |
| Acetaldehyde | ISBT 11.0 (GC/FID) | 0.1 uL/L to 100 uL/L (ppm by volume)-dilution dependent | 5 - 10 % of reading relative across the range | daily blank, daily standard within 10 % of calibration, secondary standard after calibration |
| Sulfur Dioxide | ISBT 14.0 (GC/SCD) | 0.01 uL/L to 50 uL/L (ppm by volume)-dilution dependent | 5 - 10 % of reading relative across the range | daily blank, daily standard within 10 % of calibration, secondary standard after calibration |
| Hydrogen Sulfide | ISBT 14.0 (GC/SCD) | 0.01 uL/L to 50 uL/L (ppm by volume)-dilution dependent | 5 - 10 % of reading relative across the range | daily blank, daily standard within 10 % of calibration, secondary standard after calibration |
| Ethanol | ISBT 11.0 (GC/FID) | 0.1 uL/L to 100 uL/L (ppm by volume)-dilution dependent | 5 - 10 % of reading relative across the range | daily blank, daily standard within 10 % of calibration, secondary standard after calibration |
| CO₂ Purity | ISBT 2.0 Caustic absorption Zahn-Nagel | 99.00% to 99.99% | ± 10 % of reading | User calibration per manufacturer recommendation |
| | ALI method SAM 4.1 subtraction method (GC/DID) | 1 ppm for each target analyte (analyte dependent) - refer to Oxygen and Nitrogen analysis. | 5-10 % relative across the range | duplicate analysis within 10 % of each other |
| | GC/TCD | 0.1 % to 100 % | 5-10 % relative across the range, RT ± 0.1 min | standard with every sample, duplicate analysis within 10 % of each other |

Note 1: An equivalent method may be employed with the prior approval of the UIC Program Director.

Table 9. Summary of analytical parameters for corrosion coupons.

| Parameters | Analytical Methods | Detection Limit/Range | Typical Precisions | QC Requirements |
|-------------------|---------------------------|------------------------------|---------------------------|--|
| Mass | NACE RP0775-2005 | .005mg | +/-2% | Annual Calibration of Scale (3 rd Party Aldinger Co. – Cert #664896F) |
| Thickness | NACE RP0775-2005 | .001mm | +/-005mm | Factory calibration |

Table 10. Summary of measurement parameters for field gauges.

| Parameters | Methods | Detection Limit/Range | Typical Precisions | QC Requirements |
|--|------------------|---|---------------------------|---|
| Booster pump discharge pressure (PIT-012) | ANSI Z540-1-1994 | +/- 0.001 psi / 0-3000 psi | +/- 0.01 psi | Annual Calibration of Scale (3 rd party) |
| Injection Tubing Temperature (TIT-019) | ANSI Z540-1-1994 | +/- 0.001 F / 0-500 F | +/- 0.01 F | Annual Calibration of Scale (3 rd party) |
| Annulus Pressure (PIT-014) | ANSI Z540-1-1994 | +/- 0.001 psi / 0-3000 psi | +/- 0.01 psi | Annual Calibration of Scale (3 rd party) |
| Injection Tubing Pressure (PIT-009) | ANSI Z540-1-1994 | +/- 0.001 psi / 0-3000 psi | +/- 0.01 psi | Annual Calibration of Scale (3 rd party) |
| Injection Mass Flow Rate (FIT-006) | UNKNOWN | +/- 0.1000% of rate / 50,522-303,133 lb/hr | +/- 0.01 lbs/hr | Annual Calibration of Scale (3 rd party) |
| Westbay Pressures (MOSDAX) | UNKNOWN | +/- 0.01 psi / 0-4000 PSI | +/- 0.1 psi | Annual Calibration of Scale (3 rd party) |

Table 11. Actionable testing and monitoring outputs.

| | Project Action Limit | Detection Limit | Anticipated Reading |
|---|--|--|---|
| MIT—Pulse neutron logging | Action taken when RST indicates CO ₂ outside of expected range | +/- 0.5 SIGM | Brine saturated ~ 60 CO ₂ saturated ~ 8 |
| Wellbore integrity—annular pressure gauge | <3% pressure loss over 1 hour | Refer to Appendix A (annular pressure gauge table) | >3% pressure loss over 1 hour |
| Surface and downhole pressure gauges | Action will be taken when pressures are well outside of modeled/expected range | Refer to Table 11 and 12 for surface gauges Refer to Table 9 for downhole gauge | Within injection formation: >80% fracture gradient 0.71 psi/ft |
| Wellbore integrity—DTS fiber optic temperature | Action will be taken when there is an anomaly in temperature profile | Refer to Appendix A | DTS provides continuous temperature profile |
| Seismic data files | Detected CO ₂ outside the AOR | Dependent on fluid saturation, and formation velocities | CO ₂ plume migration similar to modeled outcome |

A.4.b. Precision

For groundwater sampling, data accuracy will be assessed by the collection and analysis of field blanks to test sampling procedures and matrix spikes to test lab procedures. Field blanks will be taken no less than one per sampling event to spot check for sample bottle contamination. Laboratory assessment of analytical precision will be the responsibility of the individual laboratories per their standard operating procedures.

Table 12 summarizes the specifications of each monitoring method. For direct pressure and logging measurements, precision data is presented in Table 13.

A.4.c. Bias

Laboratory assessment of analytical bias will be the responsibility of the individual laboratories per their standard operating procedures and analytical methodologies. For direct pressure or logging measurements, there is no bias.

A.4.d. Representativeness

For groundwater sampling, data representativeness expresses the degree to which data accurately and precisely represents a characteristic of a population, parameter variations at a sampling point, a process condition, or an environmental condition. The sampling network has been designed to provide data representative of site conditions. For analytical results of individual groundwater samples, representativeness will be estimated by ion and mass balances. Ion balances with ±10% error or less will be considered valid. Mass balance assessment will be used in cases where the ion balance is greater

than $\pm 10\%$ to help determine the source of error. For a sample and its duplicate, if the relative percent difference is greater than 10%, the sample may be considered non-representative.

A.4.e. Completeness

For groundwater sampling, data completeness is a measure of the amount of valid data obtained from a measurement system compared to the amount that was expected to be obtained under normal conditions. It is anticipated that data completeness of 90% for groundwater sampling will be acceptable to meet monitoring goals. For direct pressure and temperature measurements, it is expected that data will be recorded no less than 90% of the time.

A.4.f. Comparability

Data comparability expresses the confidence with which one data set can be compared to another. The data sets to be generated by this project will be very comparable to future data sets because of the use of standard methods and the level of QA/QC effort. If historical groundwater quality data become available from other sources, their applicability to the project and level of quality will be assessed prior to use with data gathered on this project. Direct pressure, temperature, and logging measurements will be directly comparable to previously obtained data.

A.4.g. Method Sensitivity

Table 14 through Table 19 provide additional details on gauge specifications and sensitivities.

Table 12. Pressure and temperature—downhole quartz gauge specifications.

| | |
|--------------------------------------|--|
| Calibrated working pressure range | Atmospheric to 10,000 psi |
| Initial pressure accuracy | $< \pm 2$ psi over full scale |
| Pressure resolution | 0.005 psi at 1-s sample rate |
| Pressure drift stability | $< \pm 1$ psi per year over full scale |
| Calibrated working temperature range | 77–266°F |
| Initial temperature accuracy | $< \pm 0.9^\circ\text{F}$ per $\pm 0.27^\circ\text{F}$ |
| Temperature resolution | 0.009°F at 1-s sample rate |
| Temperature drift stability | $< \pm 0.1^\circ\text{F}$ per year at 302 |
| Max temperature | 302°F |

Table 13. Representative Logging tool specifications.

| | RST | CBL | USI | Isolation Scanner |
|----------------------------|-------------|--------------------------------|--|--|
| Logging speed | 1,800 ft/hr | 3,600 ft/hr | Standard resolution: 2,700 ft/hr High resolution: 563 ft/hr | Standard resolution: 2,700 ft/hr High resolution: 563 ft/hr |
| Vertical resolution | 15 inches | 3 ft | Standard resolution: 0.6 in High speed: 6 in | High resolution: 0.6 in High speed: 6 in |
| Investigation | Formation | Casing, annulus, and formation | Casing and annulus | Casing and annulus |
| Temperature rating | 302°F | 350°F | 350°F | 350°F |
| Pressure rating | 15,000 psi | 20,000 psi | 20,000 psi | 20,000 psi |

Table 14. Pressure Field Gauge PIT-009—Injection Tubing Pressure.

| | |
|-----------------------------------|-----------------------------------|
| Calibrated working pressure range | 0 to 3000 psi and 4–20 mA |
| Initial pressure accuracy | < 0.04375% |
| Pressure resolution | 0.001 psi and 0.00001 mA |
| Pressure drift stability | To be determined after first year |

Table 15. Pressure Field Gauge PIT-014—Annuls Pressure.

| | |
|-----------------------------------|-----------------------------------|
| Calibrated working pressure range | 0 to 3000 psi and 4–20 mA |
| Initial pressure accuracy | < 0.02500% |
| Pressure resolution | 0.001 psi and 0.00001 mA |
| Pressure drift stability | To be determined after first year |

Table 16. Pressure Field Gauge PIT-012.

| | |
|-----------------------------------|-----------------------------------|
| Calibrated working pressure range | 0 to 3000 psi and 4–20 mA |
| Initial pressure accuracy | < 0.03125% |
| Pressure resolution | 0.001 psi and 0.00001 mA |
| Pressure drift stability | To be determined after first year |

Table 17. Temperature Field Gauge TIT-019 —Injection Tubing Temperature.

| | |
|--------------------------------------|-----------------------------------|
| Calibrated working temperature range | 0 to 500°F and 4–20 mA |
| Initial temperature accuracy | < 0.0055 % |
| Temperature resolution | 0.001°F and 0.0001 mA |
| Temperature drift stability | To be determined after first year |

Table 18. Mass Flow Rate Field Gauge—FT-006 CO₂ Mass Flow Rate.

| | |
|------------------------------------|--------------------------------------|
| Calibrated working flow rate range | 50,522 to 303,133 lbs/hr and 4–20 mA |
| Initial mass flow rate accuracy | < 0.18% |
| Mass flow rate resolution | 0.0001 lb/hr |
| Mass flow rate drift stability | To be determined after first year |

Table 19. Westbay Field Gauge—Westbay (MOSDAX) Pressure.

| | |
|-----------------------------------|----------------------------------|
| Calibrated working pressure range | 0 to 4000 psi |
| Initial pressure accuracy | < 0.01 % |
| Pressure resolution | 0.001 psi |
| Pressure drift stability | To be determine after first year |

A.5. Special Training/Certifications

A.5.a. Specialized Training and Certifications

The geophysical survey equipment and wireline logging tools will be operated by trained, qualified, and certified personnel, according to the service company which provides the equipment. The subsequent data will be processed and analyzed according to industry standards (Appendix B). No specialized certifications are required for personnel conducting groundwater sampling, but field sampling will be

conducted by trained personnel. Groundwater sampling will be conducted by personnel trained to understand and follow the project specific sampling procedures. Upon request ADM will provide the agency with all laboratory SOPs developed for the specific parameter using the appropriate standard method. Each laboratory technician conducting the analysis on the samples will be trained on the SOP developed for each standard method. ADM will include the technician's training certification with the biannual report.

A.5.b/c. Training Provider and Responsibility

Training for personnel will be provided by the operator or by the subcontractor responsible for the data collection activity.

A.6. Documentation and Records

A.6.a. Report Format and Package Information

A semi-annual report from ADM to USEPA will contain all required project data, including testing and monitoring information as specified by the UIC Class VI permit. Data will be provided in electronic or other formats as required by the UIC Program Director.

A.6.b. Other Project Documents, Records, and Electronic Files

Other documents, records, and electronic files such as well logs, test results, or other data will be provided as required by the UIC Program Director.

A.6.c/d. Data Storage and Duration

ADM or a designated contractor will maintain the required project data as provided elsewhere in the permit.

A.6.e. QASP Distribution Responsibility

The ADM Corn Plant Manager will be responsible for ensuring that all those on the distribution list will receive the most current copy of the approved Quality Assurance and Surveillance Plan.

B. Data Generation and Acquisition

B.1. Sampling Process Design (Experimental Design)

Discussion in this section is focused on groundwater and fluid sampling and does not address monitoring methods that do not gather physical samples (e.g., logging, seismic monitoring, and pressure/temperature monitoring). During the pre-injection and injection phases, groundwater sampling is planned to include an extensive set of chemical parameters to establish aqueous geochemical reference data. Parameters will include selected constituents that: (1) have primary and secondary USEPA drinking water maximum contaminant levels, (2) are the most responsive to interaction with CO₂ or brine, (3) are needed for quality control, and (4) may be needed for geochemical modeling. The full set of parameters for each sampling interval is given in Table 4-Table 7. After a sufficient baseline is established, monitoring scope may shift to a subset of indicator parameters that are (1) the most responsive to interaction with CO₂ or brine and (2) are needed for quality control. Implementation of a reduced set of parameters would be done in consultation with the USEPA. Isotopic analyses will be performed on baseline samples to the degree that the information helps verify a condition or establish an understanding of non-project related variations. For non-baseline samples, isotopic analyses may be reduced in all monitoring wells if a review of the historical project results or

other data determines that further sampling for isotopes is unneeded. During any period where a reduced set of analytes is used, if statistically significant trends are observed that are the result of unintended CO₂ or brine migration, the analytical list would be expanded to the full set of monitoring parameters. The Ironton-Galesville groundwater samples will be analyzed using a laboratory meeting the requirements under the USEPA Environmental Laboratory Accreditation Program. All other samples will be analyzed by the operator or a third party laboratory. Dissolved CO₂ will be analyzed by methods consistent with Test Method B of ASTM D 513-06, "Standard Test Methods for Total and Dissolved Carbon Dioxide in Water" or equivalent. Isotopic analysis will be conducted using established methods.

B.1.a. Design Strategy

CO₂ Stream Monitoring Strategy

The primary purpose of analyzing the carbon dioxide stream is to evaluate the potential interactions of carbon dioxide and/or other constituents of the injectate with formation solids and fluids. This analysis can also identify (or rule out) potential interactions with well materials. Establishing the chemical composition of the injectate also supports the determination of whether the injectate meets the qualifications of hazardous waste under the Resource Conservation and Recovery Act (RCRA), 42 U.S.C. 6901 et seq. (1976), and/or the Comprehensive Environmental Response, Compensation, and Liability Act, (CERCLA) 42 U.S.C. 9601 et seq. (1980). Additionally, monitoring the chemical and physical characteristics of the carbon dioxide (e.g., isotopic signature, other constituents) may help distinguish the injectate from the native fluids and gases if unintended leakage from the storage reservoir occurred. Injectate monitoring is required at a sufficient frequency to detect changes to any physical and chemical properties that may result in a deviation from the permitted specifications.

Calibration of transmitters used to monitor pressures, temperatures, and flow rates of CO₂ into the injection well at the injection well and at the verification well shall be conducted annually (e.g., Durkin Equipment Company, St. Louis, MO). Reports shall contain test equipment used to calibrate the transmitters, including test equipment manufacturers, model numbers, serial numbers, calibration dates and expiration dates.

Corrosion Monitoring Strategy

Corrosion coupon analyses will be conducted quarterly to aid in ensuring the mechanical integrity of the equipment in contact with the carbon dioxide. Coupons shall be sent quarterly to a company for analysis (e.g., SGS) and an analysis conducted in accordance with NACE Standard RP-0775 (or similar) to determine and document corrosion wear rates based on mass loss.

Shallow Groundwater Monitoring Strategy

Four dedicated monitoring wells have been selected for shallow groundwater monitoring. These wells have already been installed and screened in the Quaternary-age deposits to depths less than 150 ft below ground surface (bgs). The local Quaternary-age deposits are used predominantly as private water well sources in the area. The wells are designated as IL-ICCS-MVA 10LG, IL-ICCS-MVA 11LG, IL-ICCS-MVA 12LG, and IL-ICCS-MVA 13LG (Figure 2). The wells were selected to give a spatial distribution around the planned CO₂ injection well (CCS#2) location.

Deep Groundwater Monitoring Strategy

Monitoring of the deeper St. Peter and Ironton-Galesville Sandstones will be used for early leakage detection in formations that are much closer to the Mt. Simon Sandstone injection reservoir. Fluid sampling at wells VW#1, VW#2, and GM#2 in combination with pressure monitoring, temperature monitoring, and pulse neutron logging will be used to determine if leakage is occurring at or near the injection well. The Ironton-Galesville Sandstone, has sufficient permeability (over 100 mD) such that

pressure monitoring at the verification wells would detect a failure of the confining zone should it occur. MIT testing and DTS monitoring at the injection well will also provide data to insure the mechanical integrity of the well is maintained. With the planned sampling and monitoring frequencies, it is expected that baseline conditions can be documented, natural variability in conditions can be characterized, unintended brine or CO₂ leakage could be detected if it occurred, and sufficient data will be collected to demonstrate that the effects of CO₂ injection are limited to the intended storage reservoir. No groundwater fluid sampling is planned for the Mt Simon intervals where free phase CO₂ has broken through.

GM#2 Sampling

The IL-ICCS geophysical monitoring well, GM#2, will be used for fluid sampling of the St. Peter Sandstone, a USEPA identified USDW. At prescribed frequencies (in consultation with USEPA), fluid sampling will occur using a portable swabbing rig or other available sampling technologies. Samples will be analyzed for constituents listed in Table 5 to document baseline fluid chemistry and to detect changes in fluid chemistry that could result from the movement of brine or CO₂ from the storage interval through the seal formation.

VW#1 Sampling

The IBDP verification well, VW#1, will be used to monitor the pressure and temperature in the Ironton-Galesville Sandstone above the Eau Claire Formation, the primary reservoir seal. This well will serve as an early leak detection system by allowing the operator to monitor for changes above the primary caprock. Groundwater samples will be collected and analyzed for constituents listed in Table 6 to document baseline fluid chemistry and to detect changes in fluid chemistry that could result from the movement of brine or CO₂ from the storage interval through the seal formation. The well has been completed with a Westbay multilevel sampling system and fluid samples will be collected as described by Locke et al. (2013).

VW#2 Sampling

The IL-ICCS verification well, VW#2, will allow monitoring within the Mt. Simon injection zone as well as immediately above the Eau Claire Formation. This well will serve as an early leak detection system by allowing the operator to monitor for changes above the primary caprock. VW#2 will be equipped with a multilevel pressure and temperature monitoring system with fluid sampling capability at four (4) intervals. The system uses packers to isolate each perforation interval and hydraulically operated sliding sleeves to facilitate sampling. Pressure and temperature will be continuously monitored and recorded in each of the five (5) perforation intervals. The pressure inside the tubing just above the uppermost packer (~4900 Kb) will be monitored and recorded. At prescribed frequencies (in consultation with USEPA), fluid sampling will occur by opening the appropriate sliding sleeve across from the zone to be sampled. Each sample interval will be analyzed for constituents listed in Table 6 for the Ironton Galesville or Table 7 for the Mt Simon to document baseline fluid chemistry and to detect changes in fluid chemistry that could result from the movement of brine or CO₂ from the storage interval through the seal formation.

B.1.b Type and Number of Samples/Test Runs

Groundwater sampling frequencies are detailed in Table 1.

CO₂ gas stream and corrosion coupon frequencies are detailed in Table 1.

B.1.c. Site/Sampling Locations

Shallow groundwater monitoring will use existing wells IL-ICCS-MVA 10LG, IL-ICCS-MVA 11LG, IL-ICCS-MVA 12LG, and IL-ICCS-MVA 13LG (Figure 2) as noted in Section B.1.a. Deep groundwater monitoring will use existing wells VW#1, VW#2, and GM#2 (Figure 2) as noted in Section B.1.a.

CO₂ gas stream and corrosion coupon sampling locations will occur in the compressor building after the last stage of compression.

B.1.d. Sampling Site Contingency

The shallow and deep groundwater monitoring wells are located on property of the project participants (e.g., ADM, Richland Community College) and access permissions have already been granted. No problems of site inaccessibility are anticipated. If inclement weather makes site access difficult, sampling schedules will be reviewed and alternative dates may be selected that would still meet permit-related conditions.

No problems of site inaccessibility are anticipated for CO₂ gas stream or corrosion coupon sampling. If inclement weather makes site access difficult, sampling schedules will be reviewed and alternative dates may be selected that would still meet permit related conditions.

B.1.e. Activity Schedule

The groundwater sampling activities and frequencies are summarized in Table 1.

The CO₂ gas stream and corrosion coupon sampling activities and frequencies are summarized in Table 1.

B.1.f. Critical/Informational Data

During both groundwater sampling and analytical efforts, detailed field and laboratory documentation will be taken. Documentation will be recorded in field and laboratory forms and notebooks. Critical information will include time and date of activity, person/s performing activity, location of activity (well-field sampling) or instrument (lab analysis), field or laboratory instrument calibration data, field parameter values. For laboratory analyses, much of the critical data are generated during the analysis and provided to end users in digital and printed formats. Noncritical data may include appearance and odor of the sample, problems with well or sampling equipment, and weather conditions.

B.1.g. Sources of Variability

Potential sources of variability related to monitoring activities include (1) natural variation in fluid quality, formation pressure and temperature and seismic activity; (2) variation in fluid quality, formation pressure and temperature, and seismic activity due to project operations; (3) changes in recharge due to rainfall, drought, and snowfall; (4) changes in instrument calibration during sampling or analytical activity; (5) different staff collecting or analyzing samples; (6) differences in environmental conditions during field sampling activities; (7) changes in analytical data quality during life of project; and (8) data entry errors related to maintaining project database.

Activities to eliminate, reduce, or reconcile variability related to monitoring activities include (1) collecting long-term baseline data to observe and document natural variation in monitoring parameters, (2) evaluating data in timely manner after collection to observe anomalies in data that can be addressed be resampled or reanalyzed, (3) conducting statistical analysis of monitoring data to determine whether variability in a data set is the result of project activities or natural variation, (4) maintaining weather-related data using on-site weather monitoring data or data collected near project site (such as from local

airports), (5) checking instrument calibration before, during and after sampling or sample analysis, (6) thoroughly training staff, (7) conducting laboratory quality assurance checks using third party reference materials, and/or blind and/or replicate sample checks, and (8) developing a systematic review process of data that can include sample-specific data quality checks (i.e., cation/anion balance for aqueous samples).

B.2. Sampling Methods

Logging, geophysical monitoring, and pressure/temperature monitoring does not apply to this section, and is omitted.

B.2.a/b. Sampling SOPs

Groundwater samples will be collected primarily using a low-flow sampling method consistent with ASTM D6452-99 (2005) or Puls and Barcelona (1996). If a flow-through cell is not used, field parameters will be measured in grab samples. Groundwater wells will be purged to ensure samples are representative of formation water quality. Static water levels in each well will be determined using an electronic water level indicator before any purging or sampling activities begin. Dedicated pumps (e.g., bladder pumps) will be installed in each monitoring well to minimize potential cross contamination between wells. Groundwater pH, temperature, specific conductance, and dissolved oxygen will be monitored in the field using portable probes and a flow-through cell consistent with standard methods (e.g., APHA, 2005) given sufficient flow rates and volumes. Field chemistry probes will be calibrated at the beginning of each sampling day according to equipment manufacturer procedures using standard reference solutions. When a flow-through cell is used, field parameters will be continuously monitored and will be considered stable when three successive measurements made three minutes apart meet the criteria listed in Table 20.

Table 20. Stabilization criteria of water quality parameters during shallow well purging.

| FIELD PARAMETER | STABILIZATION CRITERIA |
|----------------------|---|
| pH | +/- 0.2 units |
| Temperature | +/- 1°C |
| Specific Conductance | +/- 3% of reading in $\mu\text{S}/\text{cm}$ |
| Dissolved Oxygen | +/- 10% of reading or 0.3 mg/L whichever is greater |

After field parameters have stabilized, samples will be collected. Samples requiring filtration will be filtered through 0.45 μm flow-through filter cartridges as appropriate and consistent with ASTM D6564-00. Prior to sample collection, filters will be purged with a minimum of 100 mL of well water (or more if required by the filter manufacturer). For alkalinity and total CO_2 samples, efforts will be made to minimize exposure to the atmosphere during filtration, collection in sample containers, and analysis.

For deep groundwater sampling of VW#1, ISGS-SOP-WB-V1.14 (dated August 10, 2012) will be used for the collection and processing of Westbay samples. Wells GM#2 and VW#2 will not have a Westbay installation for sampling and are anticipated to use a wireline sampling system with a sampling device (e.g., Kuster sampler or similar) capable of collecting a sample from a discrete interval. Samples from GM#2 and VW#2 will be processed in a manner consistent with ISGS-SOP-WB-V1.14.

VW#1 was developed and purged extensively at the time of completion and similar plans to develop VM#2 are in place and will be executed when completion occurs. Prior to sampling, each zone will be purged to ensure representative samples are collected. Due to the extensive well development, the

amount of fluid to be purged at the time of sampling will be relatively small. If a three-foot zone is perforated (similar to VW#1), then the annular space between the 2-7/8-in. tubing and the 5-1/2-in. casing is only 1.92 gal. Thus, relatively small purge volumes will adequately refresh each isolated sampling interval. Similar purging techniques will be used for VW#1 and VW#2. Additional information about sampling procedures at VW#1 are given in Locke et al. (2013).

For VW#2, it is anticipated that air lifting with nitrogen will be used to draw fluid into the well for purging. A gas lift valve will be placed in the tubing string at approximately 1,200 ft below ground surface at the time of the completion. The sampler will be positioned at the same elevation as the discrete perforated interval, and a sample would be collected after sufficient purging.

B.2.c. In-situ Monitoring.

In-situ monitoring of groundwater chemistry parameters is not currently planned.

B.2.d. Continuous Monitoring.

Pressure data will be collected from shallow groundwater wells on a periodic basis (e.g., hourly to daily) using dedicated pressure transducers with data loggers to generally characterize shallow water level trends. These data are informational only.

B.2.e. Sample Homogenization, Composition, Filtration.

Described in section B.2.b.

B.2.f. Sample Containers and Volumes

For CO₂ stream monitoring, samples will be collected in a clean sample container rated for the appropriate collection pressure (i.e. mini cylinders or polybags provided by Airborne Labs International Inc., Somerset, NJ).

Assay for CO₂ Quarterly Gas Analysis:

- CO₂ Purity (% v/v, [GC])
- Oxygen (O₂, ppm v/v)
- Nitrogen (N₂, ppm v/v)
- Carbon Monoxide (CO, ppm v/v)
- Oxides of Nitrogen (NO_x, ppm v/v)
- Total Hydrocarbons (THC, ppm v/v as CH₄)
- Methane (CH₄, ppm v/v)
- Acetaldehyde (AA, ppm v/v)
- Sulfur Dioxide (SO₂, ppm v/v)
- Hydrogen Sulfide (H₂S ppm v/v)
- Ethanol (ppm v/v)

For shallow and deep groundwater samples, all sample bottles will be new. Sample bottles and bags for analytes will be used as received (ready for use) from the vendor or contract analytical laboratory for the analyte of interest. A summary of sample containers is presented in Table 22.

B.2.g. Sample Preservation

For groundwater and other aqueous samples, the preservation methods in Table 22 will be used.

No preservation is required or used for CO₂ gas stream, and additional details of sampling requirements are shown in Table 21. Corrosion coupon sampling only requires that the coupons be physically separated (e.g., sleeves, baggies) during transportation to prevent physical abrasion.

Table 21. Summary of sample containers, preservation treatments, and holding times for CO₂ gas stream analysis.

| Target Parameters | Volume/Container Material | Preservation Technique | Sample Holding time (max) |
|----------------------------|--|-------------------------|---------------------------|
| CO ₂ gas stream | (2) 2L MLB Polybags (1) 75 cc Mini Cylinder | Sample Storage Cabinets | 5 Business Days |

B.2.h. Cleaning/Decontamination of Sampling Equipment

Dedicated pumps (e.g., bladder pumps) will be installed in each groundwater monitoring well to minimize potential cross contamination between wells. These pumps will remain in each well throughout the project period except for maintenance. Prior to installation, the pumps will be cleaned on the outside with a non-phosphate detergent. Pumps will be rinsed a minimum of three times with deionized water and a minimum of 1 L of deionized water will be pumped through pump and sample tubing. Individual cleaned pumps and tubing will be placed in plastic garbage bags for transport to the field for installation. All field glassware (pipets, beakers, filter holders, etc.) are cleaned with tap water to remove any loose dirt, washed in a dilute nitric acid solution, and rinsed three times with deionized water before use.

CO₂ gas stream sampling containers will be either disposed or decontaminated by the analytical lab. No sampling equipment will be utilized with the corrosion coupons or annual field gauge calibrations.

B.2.i Support Facilities

For sampling of groundwater, the following are required: air compressor, vacuum pump, generator, multi-electrode water quality sonde, analytical meters (pH, specific conductance, etc.). Field activities are usually completed in field vehicles and portable laboratory trailers located on site.

Sampling tubing, connectors and valves required to sample the CO₂ gas stream will be supplied by the analytical lab providing the sampling containers. Sampling will occur within the existing CO₂ compression building.

Similarly, corrosion coupons will be removed from the CO₂ injection line within the existing CO₂ compression building.

Field gauges will be removed from the injection well and verification well utilizing existing standard industry tools and equipment. Deployment and retrieval of verification well gauges will be done using procedures and equipment recommended by the vendor, subcontractor, or is standard per industry practice.

B.2.j. Corrective Action, Personnel, and Documentation

Field staff will be responsible for properly testing equipment and performing corrective actions on broken or malfunctioning field equipment. If corrective action cannot be taken in the field, then equipment will be returned to the manufacturer for repair or replaced. Significant corrective actions affecting analytical results will be documented in field notes.

B.3. Sample Handling and Custody

Logging, geophysical monitoring, and pressure/temperature monitoring does not apply to this section, and is omitted.

Sample holding times (Table 22) will be consistent with those described in US EPA (1974), American Public Health Association (APHA, 2005), Wood (1976), and ASTM Method D6517-00 (2005). After collection, samples will be placed in ice chests in the field and maintained thereafter at approximately 4°C until analysis. The samples will be maintained at their preservation temperature and sent to the designated laboratory within 24 hours. Analysis of the samples will be completed within the holding time listed in Table 22. As appropriate, alternative sample containers and preservation techniques approved by the UIC Program Director will be used to meet analytical requirements.

B.3.a Maximum Hold Time/Time Before Retrieval

See Table 22.

B.3.b. Sample Transportation

See description at the beginning of Section B.3.

B.3.c. Sampling Documentation

Field notes will be collected for all groundwater samples collected. These forms will be retained and archived as reference. The sample documentation is the responsibility of groundwater sampling personnel.

An analysis authorization form shall be provided with each CO₂ gas stream sample provided for analysis as shown by the example in Figure 4.

B.3.d. Sample Identification

All sample bottles will have waterproof labels with information denoting project, sampling date, sampling location, sample identification number, sample type (freshwater or brine), analyte, volume, filtration used (if any), and preservative used (if any). See Figure 3 for an example of a label.

Table 22. Summary of anticipated sample containers, preservation treatments, and holding times.

| Target Parameters | Volume/Container Material | Preservation Technique | Sample Holding time | Relative Sampling Depth |
|--|---------------------------|---------------------------------|---------------------|-------------------------|
| Cations: Ca, Fe, K, Mg, Na, Si, Al, Ba, Mn, As, Cd, Cr, Cu, Pb, Sb Se, Tl | 250 ml/HDPE | Filtered, nitric acid, cool 4°C | 60 days | Shallow |
| Dissolved CO₂ | 2 × 60 ml/HDPE | Filtered, cool 4°C | 14 days | Shallow |
| Dissolved CO₂ | 60 ml/HDPE | Filtered, cool 4°C | 14 days | Deep |
| Isotopes: ³ H, δD, δ ¹⁸ O, δ ³⁴ S, and δ ¹³ C | 2 × 60 ml/HDPE | Filtered, cool 4°C | 4 weeks | Shallow |
| Isotopes: δ ³⁴ S | 250 ml/HDPE | Filtered, cool 4°C | 4 weeks | Deep |
| Isotopes: δD, δ ¹⁸ O, δ ¹³ C | 60 ml/HDPE | Filtered, cool 4°C | 4 weeks | Deep |
| Alkalinity, anions (Br, Cl, F, NO ₃ , SO ₄) | 500 ml/HDPE | Filtered, cool 4°C | 45 days | Shallow |
| Field Confirmation: Temperature, dissolved oxygen, specific conductance, pH | 200 ml/glass jar | None | < 1 hour | Deep |
| Field Confirmation: Density | 60 ml/HDPE | Filtered | < 1 hour | Deep |

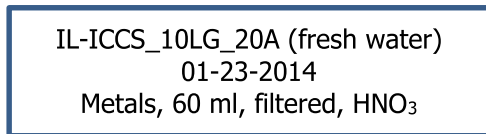

Figure 3. Example label for groundwater sample bottles.

B.3.e. Sample Chain-of-Custody

For CO₂ stream analysis, an analysis authorization form (Figure 4) will accompany the sample to the lab at which point a chain-of-custody accompanies the sample through their processes.

For groundwater samples, chain-of-custody will be documented using a standardized form. A typical form is shown in Figure 5, and it or a similar form will be used for all groundwater sampling. Copies of the form will be provided to the person/lab receiving the samples as well as the person/lab transferring the samples. These forms will be retained and archived to allow simplified tracking of sample status. The chain-of-custody form and record keeping is the responsibility of groundwater sampling personnel.

B.4. Analytical Methods

Logging, geophysical monitoring, and pressure/temperature monitoring does not apply to this section, and is omitted.

B.4.a. Analytical SOPs

Analytical SOPs are referenced in Table 4-Table 7. Other laboratory specific SOPs utilized by the laboratory will be determined after a contract laboratory has been selected. Upon request ADM will provide the agency with all laboratory SOPs developed for the specific parameter using the appropriate standard method. Each laboratory technician conducting the analysis on the samples will be trained on the SOP developed for each standard method. ADM will include the technician's training certification with the biannual report.

B.4.b. Equipment/Instrumentation Needed

Equipment and instrumentation is specified in the individual analytical methods referenced in Table 4-Table 7.

B.4.c. Method Performance Criteria

Nonstandard method performance criteria are not anticipated for this project.

B.4.d. Analytical Failure

Each laboratory conducting the analyses in Table 4-Table 7 will be responsible for appropriately addressing analytical failure according to their individual SOPs.

B.4.e. Sample Disposal

Each laboratory conducting the analyses in in Table 4-Table 7 will be responsible for appropriate sample disposal according to their individual SOPs.

B.4.f Laboratory Turnaround

Laboratory turnaround will vary by laboratory, but generally turnaround of verified analytical results within one month will be suitable for project needs.

B.4.g. Method Validation for Nonstandard Methods

Nonstandard methods are not anticipated for this project. If nonstandard methods are needed or proposed in the future, the USEPA will be consulted on additional appropriate actions to be taken.

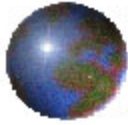

Airborne Labs International, Inc.

22C World's Fair Drive, Somerset, NJ 08873 Fax: 732-302-3035 Phone: 732-302-1950
E-mail: airborne@airbornelabs.com Website: www.airbornelabs.com

Analysis Authorization

This form **MUST** be completed & returned with a sample shipment

1.) Report Results to*:

| | | | |
|-------------------------|-------|--|-------|
| Company: | _____ | Sampled On (mm/dd/yy): | _____ |
| Address: | _____ | P.O. #: | _____ |
| Address: | _____ | Credit Card: Visa Amex MasterCard Discover | |
| Address: | _____ | Card #: | _____ |
| Address: | _____ | Cardholder: | _____ |
| Attention: | _____ | Exp. Date: | _____ |
| Telephone: (____) _____ | | Check #: | _____ |
| Fax: (____) _____ | | Other: | _____ |
| E-Mail: | _____ | Pricing Discussed/Quoted? Y N | |

*Please attach complete billing address if different from reporting address.

2.) Number of Samples Submitted: _____ Container Type(s): _____

3.) Sample Description (circle):

Liquid CO₂ CO₂ (Final) Vapor CO₂ Feedgas* CO₂ In-Process
Food Grade CO₂ LIN LOX LAR RELOX (Reboiler) ABO

*If CO₂ Feedgas -Identify source (e.g. Ethanol/Ammonia/Nat. Well/Ethylene/Combustion, Self-Gen, etc.) _____

Aviator Breathing Oxygen (ABO) Natural Gas Refinery Gas Syn Gas Propane Butane Air Oxygen
Nitrogen Argon Hydrogen Helium Neon Xenon Krypton Freon® Refrigerant
Gas Mixture Fuel Oil Lubricant

Other (Describe): _____

4.) Sample Type (Check) : Industrial _____ Medical _____ MilSpec _____ Other _____

(attach a log for multiple samples)

5.) Sample ID: _____

6.) Potential Hazards/Safety Issues: _____

7.) Analytical Test(s) Requested (check program or select individual tests required where applicable):

Std ISBT/Vendor CO₂ Test Program _____ Std CO₂ Feedgas Program _____ Std CGA Test Program _____ Std Medical Gas _____
Std Contract Program _____ Std ASTM Test Program _____ MIL Spec Test Program _____

%Purity THC CH₄ TNMHC Vol Hydrocarbons (C1-C6) BTEX Water Vapor NVR/NVOR Oil/Grease Total Sulfur H₂S SO₂
COS MeSH t-Butyl Mercaptan Vol Sulfur Compnds Odorants Total Nitrogen N₂ NO₂ NH₃ NO NO₂ HCN Nitrous Oxide (N₂O)
PH₃ Oxygen Argon Hydrogen Helium CO CO₂ Xenon Neon Krypton Vinyl Chloride Acetaldehyde Vol Oxygenates GC/MS Scan
IR Scan IR Microscope Halogenated Hydrocarbons SF₆ Gas Mixture% Btu (Heat) Content % CHNO Sediment Wt Patch Test
Viscosity Flash/Fire Point Density Specific Gravity Trace Metals TAN TBN XRF SEM-XRF Scan Light Microscope

Other Testing: _____

8.) Sample Disposition

Retain for _____ Period Perform Clean-up/Maintenance Actions & Return* _____ Report for Instructions _____

Other: _____

*Supply all return addresses & shipping instructions

9.) Report Disposition (circle one): E-Mail _____ Fax _____ Mail _____ Telephone _____ Other: _____

(Reports will be sent to the address & contact(s) specified at the top of this form)

10.) Priority Conditions (circle), Note: Additional fees will apply for non-std test scheduling:

Standard _____ 2-Work Day _____ 1-Work Day _____ Same Day _____ Emergency _____ Other: _____

Analytical testing **cannot be performed** unless this form is completed & returned

Figure 4. Example of CO₂ gas stream analysis authorization form.



CHAIN OF CUSTODY RECORD (Page __ of __)

Illinois State Water Survey – Analytical Services Group
 Illinois State Geological Survey – Geochemistry Section

For Midwest Geological Sequestration Consortium (MGSC) Projects

| | MGSC ID | ISGS MVA ID | Matrix | Date Collected | Time Collected | Sampling Team | Circle analyses to be performed |
|----|---------|-------------|--------|----------------|----------------|---------------|---|
| 1 | | | | | | | anions, cations, TDS, alk, NH ₃ , NVOC |
| 2 | | | | | | | anions, cations, TDS, alk, NH ₃ , NVOC |
| 3 | | | | | | | anions, cations, TDS, alk, NH ₃ , NVOC |
| 4 | | | | | | | anions, cations, TDS, alk, NH ₃ , NVOC |
| 5 | | | | | | | anions, cations, TDS, alk, NH ₃ , NVOC |
| 6 | | | | | | | anions, cations, TDS, alk, NH ₃ , NVOC |
| 7 | | | | | | | anions, cations, TDS, alk, NH ₃ , NVOC |
| 8 | | | | | | | anions, cations, TDS, alk, NH ₃ , NVOC |
| 9 | | | | | | | anions, cations, TDS, alk, NH ₃ , NVOC |
| 10 | | | | | | | anions, cations, TDS, alk, NH ₃ , NVOC |
| 11 | | | | | | | anions, cations, TDS, alk, NH ₃ , NVOC |
| 12 | | | | | | | anions, cations, TDS, alk, NH ₃ , NVOC |
| 12 | | | | | | | |

| CHAIN OF CUSTODY | | |
|--|------------------|----------------|
| Relinquished by: | Print Name: | Date and Time: |
| Received by: | Print Name: | Date and Time: |
| General Remarks: - Field parameters are to be recorded on separate sheets by sampling teams. - Any special laboratory instructions or remarks should be made below. | | |
| Data Contacts: | Fund: | |
| Billing Contact: | Billing Address: | |
| Send Data To: | | |

Remarks:

Rev. Oct. 2011 (RL)

Figure 5. Example chain-of-custody form.

B.5. Quality Control

Geophysical monitoring and pressure/temperature monitoring does not apply to this section, and is omitted. For log quality control, please refer to Appendix B.

B.5.a. QC activities

Blanks

For shallow groundwater sampling, a field blank will be collected and analyzed for the inorganic analytes in Table 4-Table 7 at a frequency of 10% or greater. Field blanks will be exposed to the same field and transport conditions as the groundwater samples. Blanks will also be utilized for deep groundwater sampling and analyzed for the inorganic analytes in Table 4-Table 7 at a frequency of 10% or greater. Field blanks will be used to detect contamination resulting from the collection and transportation process.

Duplicates

For each shallow groundwater sampling round, a duplicate groundwater sample is collected from a well from a rotating schedule. Duplicate samples are collected from the same source immediately after the original sample in different sample containers and processed as all other samples. Duplicate samples are used to assess sample heterogeneity and analytical precision.

B.5.b. Exceeding Control Limits

If the sample analytical results exceed control limits (i.e., ion balances > ±10%), further examination of the analytical results will be done by evaluating the ratio of the measured total dissolved solids (TDS) to the calculated TDS (i.e., mass balance) per APHA method. The method indicates which ion analyses should be considered suspect based on the mass balance ratio. Suspect ion analyses are then reviewed in the context of historical data and interlaboratory results, if available. Suspect ion analyses are then brought to the attention of the analytical laboratory for confirmation and/or reanalysis. The ion balance is recalculated, and if the error is still not resolved, suspect data are identified and may be given less importance in data interpretations.

B.5.c. Calculating Applicable QC Statistics

Charge Balance

The analytical results are evaluated to determine correctness of analyses based on anion-cation charge balance calculation. Because all potable waters are electrically neutral, the chemical analyses should yield equally negative and positive ionic activity. The anion-cation charge balance will be calculated using the formula:

$$\% \text{ difference} = 100 \frac{\sum \text{cations} - \sum \text{anions}}{\sum \text{cations} + \sum \text{anions}}, \quad (\text{Equation 1})$$

where the sums of the ions are represented in milliequivalents (meq) per liter and the criteria for acceptable charge balance is ±10%.

Mass Balance

The ratio of the measured TDS to the calculated TDS will be calculated in instances where the charge balance acceptance criteria are exceeded using the formula:

$$1.0 < \frac{\text{measured TDS}}{\text{calculated TDS}} < 1.2, \quad (\text{Equation 2})$$

where the anticipated values are between 1.0 and 1.2.

Outliers

A determination of one or more statistical outliers is essential prior to the statistical evaluation of groundwater. This project will use the USEPA's Unified Guidance (March 2009) as a basis for selection of recommended statistical methods to identify outliers in groundwater chemistry data sets as appropriate. These techniques include Probability Plots, Box Plots, Dixon's test, and Rosner's test. The EPA-1989 outlier test may also be used as another screening tool to identify potential outliers.

B.6. Instrument/Equipment Testing, Inspection, and Maintenance

Logging tool equipment will be maintained as per wireline industry best practices (Appendix B).

For groundwater sampling, field equipment will be maintained, factory serviced, and factory calibrated per manufacturer's recommendations. Spare parts that may be needed during sampling will be included in supplies on-hand during field sampling.

For all laboratory equipment, testing, inspection and maintenance will be the responsibility of the analytical laboratory per standard practice, method-specific protocol, or NELAP requirement.

B.7. Instrument/Equipment Calibration and Frequency

Geophysical monitoring does not apply to this section, and is omitted.

B.7.a. Calibration and Frequency of Calibration

Pressure/temperature gauge calibration information is located in Table 12-Table 19. Logging tool calibration will be at the discretion of the service company providing the equipment, following standard industry practices noted in Appendix B. Calibration frequency will be determined by standard industry practices.

For groundwater sampling, portable field meters or multiprobe sondes used to determine field parameters (e.g., pH, temperature, specific conductance, dissolved oxygen) are calibrated according to manufacturer recommendations and equipment manuals (Hach, 2006) each day before sample collection begins. Recalibration is performed if any components yield atypical values or fail to stabilize during sampling.

B.7.b. Calibration Methodology

Logging tool calibration methodology will follow standard industry practices in Appendix B.

For groundwater sampling, standards used for calibration are typically 7 and 10 for pH, a potassium chloride solution yielding a value of 1413 microseimens per centimeter ($\mu\text{S}/\text{cm}$) at 25°C for specific conductance, and a 100% dissolved O_2 solution for dissolved oxygen. Calibration is performed for the pH meters per manufacturer's specifications using a 2-point calibration bounding the range of the sample. For coulometry, sodium carbonate standards (typically yielding a concentration of 4,000 mg CO_2/L) are routinely analyzed to evaluate instrument.

B.7.c. Calibration Resolution and Documentation

Logging tool calibration resolution and documentation will follow standard industry practices in Appendix B.

For groundwater sampling, calibration values are recorded in daily sampling records and any errors in calibration are noted. For parameters where calibration is not acceptable, redundant equipment may be used so loss of data is minimized.

B.8. Inspection/Acceptance for Supplies and Consumables

B.8.a/b. Supplies, Consumables, and Responsibilities

Supplies and consumables for field and laboratory operations will be procured, inspected, and accepted as required from vendors approved by ADM or the respective subcontractor responsible for the data collection activity. Acquisition of supplies and consumables related to groundwater analyses will be the responsibility of the laboratory per established standard methodology or operating procedures.

B.9. Nondirect Measurements

Seismic Monitoring Methods

B.9.a Data Sources

For time lapse seismic surveys, repeatability is paramount for accurate differential comparison. Therefore, to ensure survey quality, the locations for the shots and acquisition methodology of sequential surveys will be consistent. Once these surveys are conducted, they will be compared to a baseline survey to track and monitor plume development.

For in-zone pressure monitoring, the in-zone pressure gauges in VW#1 and VW#2 will be used to gather pressure data.

B.9.b. Relevance to Project

Time lapse seismic surveys will be used to track changes in the CO₂ plume in the subsurface. Processing and comparing subsequent surveys to a baseline will allow project managers to monitor plume growth, as well as to ensure that the plume does not move outside of the intended storage reservoir. Numerical modeling will be used to predict the CO₂ plume growth and migration over time by combining the processed seismic data with the existing geologic model.

In-zone pressure monitoring data will be used in numerical modeling to predict plume and pressure front behavior and confirm the plume stage within the AOR.

B.9.c. Acceptance Criteria

Following standard industry practices will ensure that the gathered seismic data will be used for accurate modeling and monitoring. Similar ground conditions, shot points located within tolerable limits, functional geophones, and similar seismic input signal will be used from survey to survey to ensure repeatability.

When processing seismic data, several QA checks will be done in accordance with industry standards including reformatting to Omega structured files, geometry application, amplitude compensation, predictive deconvolution, elevation statics correction, RMS amplitude gain, velocity analysis every 2 km, NMO application using picked velocities, CMP stacking, random noise attenuation, and instantaneous gain.

B.9.d. Resources/Facilities Needed

ADM will subcontract all necessary resources and facilities for the seismic monitoring, in-zone pressure monitoring, and groundwater sampling.

B.9.e. Validity Limits and Operating Conditions

For seismic surveys and numerical modeling, intraorganizational checks between trained and experienced personnel will ensure that all surveys and numerical modeling are conducted conforming to standard industry practices.

B.10. Data Management

B.10.a. Data Management Scheme

ADM or a designated contractor will maintain the required project data as provided elsewhere in the permit. Data will be backed up on tape or held on secure servers.

B.10.b. Record-keeping and Tracking Practices

All records of gathered data will be securely held and properly labeled for auditing purposes.

B.10.c. Data Handling Equipment/Procedures

All equipment used to store data will be properly maintained and operated according to proper industry techniques. ADM SCADA system and vendor data acquisition systems will interface with one another and all subsequent data will be held on a secure server.

B.10.d. Responsibility

The primary project managers will be responsible for ensuring proper data management is maintained.

B.10.e. Data Archival and Retrieval

All data will be held by ADM. These data will be maintained and stored for auditing purposes as described in section B.10.a.

B.10.f. Hardware and Software Configurations

All ADM and vendor hardware and software configurations will be appropriately interfaced.

B.10.g. Checklists and Forms

Checklists and forms will be procured and generated as necessary.

C. Assessment and Oversight

C.1. Assessments and Response Actions

C.1.a. Activities to be Conducted

Please refer to Table 1 in section A.3.a/b. (Summary of work to be performed and work schedule); groundwater quality data will be collected at the frequency outlined in that table. After completion of sample analysis, results will be reviewed for QC criteria as noted in section B.5. If the data quality fails to meet criteria set in section B.5., samples will be reanalyzed, if still within holding time criteria. If outside of holding time criteria, additional samples may be collected or sample results may be excluded from data evaluations and interpretations. Evaluation for data consistency will be performed according to procedures described in the USEPA 2009 Unified Guidance (USEPA, 2009).

C.1.b. Responsibility for Conducting Assessments

Organizations gathering data will be responsible for conducting their internal assessments. All stop work orders will be handled internally within individual organizations.

C.1.c. Assessment Reporting

All assessment information should be reported to the individual organizations project manager outlined in A.1.a/b.

C.1.d. Corrective Action

All corrective action affecting only an individual organization's data collection responsibility should be addressed, verified, and documented by the individual project managers and communicated to the other project managers as necessary. Corrective actions affecting multiple organizations should be addressed by all members of the project leadership and communicated to other members on the distribution list for the QASP. Assessments may require integration of information from multiple monitoring sources across organizations (operational, in-zone monitoring, above-zone monitoring) to determine whether correction actions are required and/or the most cost-efficient and effective action to implement. ADM will coordinate multiorganization assessments and corrective actions as warranted.

C.2. Reports to Management

C.2.a/b. QA status Reports

QA status reports should not be needed. If any testing or monitoring techniques are changed, the QASP will be reviewed and updated as appropriate in consultation with USEPA. Revised QASPs will be distributed by ADM to the full distribution list at the beginning of this document.

D. Data Validation and Usability

D.1. Data Review, Verification, and Validation

D.1.a. Criteria for Accepting, Rejecting, or Qualifying Data

Groundwater quality data validation will include the review of the concentration units, sample holding times, and the review of duplicate, blank and other appropriate QA/QC results. All groundwater quality results will be entered into a database or spreadsheet with periodic data review and analysis. ADM will retain copies of the laboratory analytical test results and/or reports. Analytical results will be reported on a frequency based on the approved UIC permit conditions. In the periodic reports, data will be presented in graphical and tabular formats as appropriate to characterize general groundwater quality and identify intrawell variability with time. After sufficient data have been collected, additional methods, such as those described in the USEPA 2009 Unified Guidance (USEPA, 2009), will be used to evaluate intrawell variations for groundwater constituents, to evaluate if significant changes have occurred that could be the result of CO₂ or brine seepage beyond the intended storage reservoir.

D.2. Verification and Validation Methods

D.2.a. Data Verification and Validation Processes

See sections D.1.a. and B.5.

Appropriate statistical software will be used to determine data consistency.

D.2.b. Data Verification and Validation Responsibility

ADM or its designated subcontractor will verify and validate groundwater sampling data.

D.2.c. Issue Resolution Process and Responsibility

ADM or its designated Coordinator will overview the groundwater data handling, management, and assessment process. Staff involved in these processes will consult with the Coordinator to determine actions required to resolve issues.

D.2.d. Checklist, Forms, and Calculations

Checklists and forms will be developed specifically to meet permit requirements. Table 23 provides an example of the type of information used for data verification of groundwater quality data.

Table 23. Example table of criteria used to evaluate data quality.

| MVA ID | Anion charge | Cation charge | Charge balance | CB rating | Calculated TDS | Measured TDS | TDS ratio | TDS rating |
|---------------|---------------------|----------------------|-----------------------|------------------|-----------------------|---------------------|------------------|-------------------|
| ICCS_10B_01A | 14.4 | 13.60 | -2.84 | pass | 760.50 | 785 | 1.0 | pass |
| ICCS_10B_02A | 14.26 | 15.06 | 2.73 | pass | 783.03 | 777 | 1.0 | pass |
| ICCS_10B_03A | 14.39 | 14.96 | 1.94 | pass | 786.86 | 806 | 1.0 | pass |
| ICCS_10B_04A | 14.39 | 14.79 | 1.38 | pass | 780.15 | 777 | 1.0 | pass |
| ICCS_10B_04B | 14.33 | 14.90 | 1.96 | pass | 780.95 | 785 | 1.0 | pass |

D.3. Reconciliation with User Requirements

D.3.a. Evaluation of Data Uncertainty

Statistical software will be used to determine groundwater data consistency using methods consistent with USEPA 2009 Unified Guidance (USEPA, 2009).

D.3.b. Data Limitations Reporting

The organization-level project managers will be responsible for ensuring that data developed by their respective organizations is presented with the appropriate data-use limitations.

ADM will use the current operating procedure on the use, sharing, and presentation of results and/or data for the IL-ICCS project. This procedure has been developed to ensure quality, internal consistency and facilitate tracking and record keeping of data end users and associated publications.

References

- APHA, 2005, *Standard methods for the examination of water and wastewater (21st edition)*, American Public Health Association, Washington, DC.
- ASTM, 2010, Method D7069-04 (reapproved 2010), *Standard guide for field quality assurance in a ground-water sampling event*, ASTM International, 100 Barr Harbor Drive, West Conshohocken, PA.
- ASTM, 2010, Method D6911-03 (reapproved 2010), *Standard guide for packaging and shipping environmental samples for laboratory analysis*, ASTM International, 100 Barr Harbor Drive, West Conshohocken, PA.
- ASTM, 2005, Method D6517-00 (reapproved 2005), *Standard guide for field preservation of ground-water samples*, ASTM International, 100 Barr Harbor Drive, West Conshohocken, PA.
- ASTM, 2005, Method D6564-00 (reapproved 2005), *Standard guide for field filtration of ground-water samples*, ASTM International, 100 Barr Harbor Drive, West Conshohocken, PA.
- ASTM, 2005, Method D6452-99 (reapproved 2005), *Standard Guide for Purging Methods for Wells Used for Ground-Water Quality Investigations*, ASTM International, 100 Barr Harbor Drive, West Conshohocken, PA.
- ASTM, 2002, Method D513-11, *Standard test methods for total and dissolved carbon dioxide in water*, ASTM International, 100 Barr Harbor Drive, West Conshohocken, PA.
- ASTM, 2002, Method D6771-02, *Standard guide for low-flow purging and sampling for wells and devices used for ground-water quality investigations*, ASTM International, 100 Barr Harbor Drive, West Conshohocken, PA.
- Gibb, J.P., R.M. Schuller, and R.A. Griffin, 1981, *Procedures for the collection of representative water quality data from monitoring wells*, Illinois State Geological Survey Cooperative Groundwater Report 7, Champaign, IL, 61 p.
- Hach Company, February 2006, *Hydrolab DS5X, DS5, and MS5 Water Quality Multiprobes User Manual*, Hach Company, 73 p.
- Larson, D.R., B.L. Herzog, and T.H. Larson, 2003, *Groundwater geology of DeWitt, Piatt, and Northern Macon Counties, Illinois*. Illinois State Geological Survey Environmental Geology 155, 35 p.
- Locke II, R., D. Larssen, W. Salden, C. Patterson, J. Kirksey, A. Iranmanesh, B. Wimmer, I. Krapac. *Preinjection reservoir fluid characterization at a CCS demonstration site: Illinois Basin – Decatur Project, USA*. Proceedings of the 11th International Conference on Greenhouse Gas Technologies, November 18–22, 2012, Kyoto, Japan. *Energy Procedia* v. 37, 2013, p. 6,424–6,433.
<http://dx.doi.org/10.1016/j.egypro.2013.06.572>

O'Dell, J.W., J.D. Pfaff, M.E. Gales, and G.D. McKee, 1984, *Test Method—The Determination of Inorganic Anions in Water by Ion Chromatography-Method 300*, U.S. Environmental Protection Agency, EPA-600/4-84-017.

Orion Research Inc., 1990, *CO₂ Electrode Instruction Manual*, Orion Research Inc., 36 p.

Puls, R.W., and M.J. Barcelona, 1996, *Low-Flow (Minimal Drawdown) Ground-Water Sampling Procedures*. U.S. Environmental Protection Agency, EPA-540/S-95/504.

U.S. Environmental Protection Agency (US EPA), 2009, *Statistical analysis of groundwater monitoring data at RCRA facilities—Unified Guidance*, US EPA, Office of Solid Waste, Washington, DC.

U.S. Environmental Protection Agency (US EPA), 1974, *Methods for chemical analysis of water and wastes*, US EPA Cincinnati, OH, EPA-625-/6-74-003a.

Wood, W.W., 1976, *Guidelines for collection and field analysis of groundwater samples for selected unstable constituents*, In U.S. Geological Survey, *Techniques for Water Resources Investigations*, Chapter D-2, 24 p.

Appendices

APPENDIX A. DTS and Down-hole Pressure Gauge Information

WellWatcher Ultra

Distributed Temperature System

APPLICATIONS

- Distributed temperature measurements
- Control of production rates and drawdown
- Monitoring
 - Reservoir flow contributions and decline
 - Gas lift optimization and tubing integrity
 - Heavy oil thermal recovery
- Production allocation
- Injection profiling
- Gas lift optimization
- Riser flow assurance

FEATURES

- Fiber-optic distributed temperature sensing technology
- No downhole electronics
- Simple-to-use surface software, with auto-setup and optimization
- Reliable, robust instrument and extended system life
- Best-in-class measurements
 - Fast temperature resolution
 - 15-km [9.32-m] range, 6 doubled-ended or 12 single-ended channel interrogation

The WellWatcher Ultra* distributed temperature system provides detailed information related to a reservoir's performance through the acquisition of temperature profiles. The extremely versatile system can measure up to 15 km [9.32 mi] of fiber at a meter's resolution, update data in just a few seconds, resolve temperatures to 0.01 degC [0.018 degF], and interrogate numerous fibers from one surface system. The data obtained are available as soon as the measurement is taken. They are communicated via various industry-standard protocols or those customized by Schlumberger's engineering team to the specifics of a particular installation. The data are combinable with data obtained by other Schlumberger sensors, and experts are available to help design the best solution for a particular situation.

ACQUISITION RESULTS

Distributed temperature sensing (DTS) acquisition is configured based on the application. This configuration is typically made up of a combination of profiles, zones, and real-time alarms. Profiles include temperature measurements taken at regular intervals along the fiber. This information can be used to measure reservoir performance and to monitor completion integrity, thereby helping ensure downstream flow. Zonal areas of interest can be specified to facilitate real-time monitoring in SCADA systems and to trigger alarms for critical indicators.

DTS DATA HANDLING

Profile data are temperature measurement profiles of the entire fiber cable consisting of a series of data points. Zone data are statistical data from a particular specified section of the fiber, processed according to specification. Alarm data trigger a signal according to specifications.

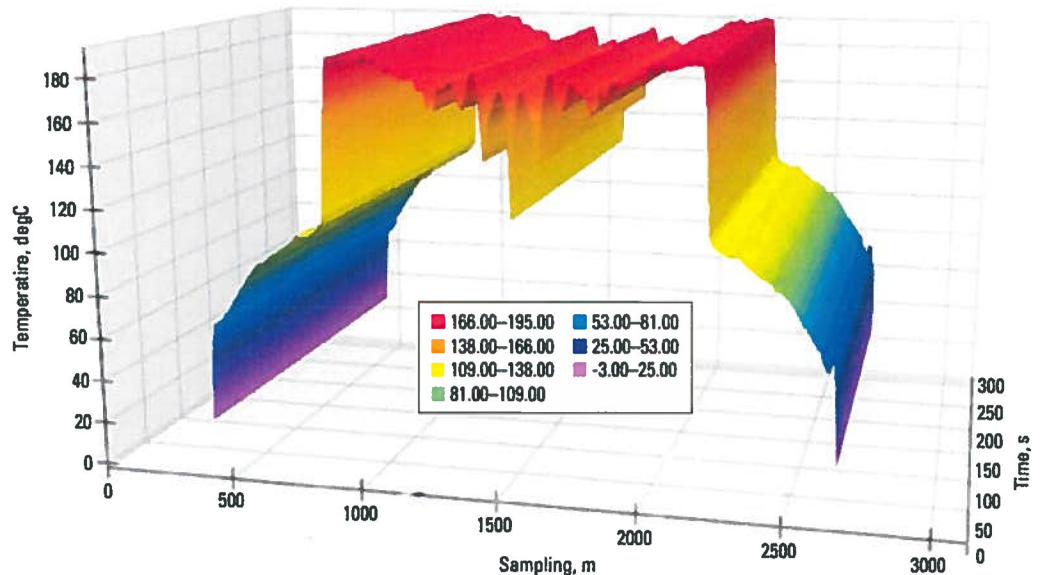

In a heavy oil steam injector, the fiber is connected to the acquisition unit at both ends (for a double-ended configuration) to provide a completely compensated correction for any losses in the fiber. This arrangement helps ensure the maximum life for the monitoring system in this aggressive working environment.

WellWatcher Ultra Distributed Temperature System

BENEFITS

- Permanent in-well reservoir monitoring
- Enhanced recovery through improved reservoir surveillance
- Improved production management
- Faster identification of production problems through best-in-class temperature resolution
- Cost-effective transient analysis
 - Fewer interventions
 - Improved optics, allowing fiber logging for a longer time, increasing system life
- Improved reliability and accuracy for high-temperature monitoring systems

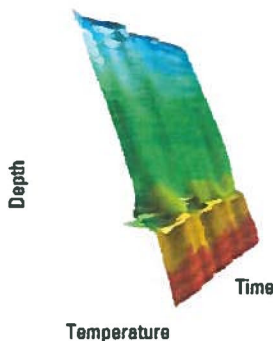

In a gas injection well with a slugging injection valve, distributed temperature measurements can quickly identify a problem valve, saving time during valve replacement and minimizing lost production.

IT INTEGRATION

The WellWatcher Ultra DTS acquisition unit has a robust database that stores all acquired data on site with local backup. In addition, various technologies are available to integrate the data seamlessly into any IT environment. Industry-standard technologies such as the Modbus communication protocol, OPC open connectivity, wellsite information transfer standard markup language (WITSML), and SQL database replication can be used to deliver the data in real time to SCADA systems, data historians, the Schlumberger InterACT* real-time monitoring and data delivery secure Web service, or simply to Microsoft Excel® software on a personal computer.

IT INTEGRATION SUCCESS

A Schlumberger client had a fiber-optic DTS installed in a production field and wanted to integrate the data into its IT environment. The client wanted the data stored and viewable locally but required that the information be quickly accessible from the main office. With the WellWatcher Ultra DTS acquisition unit, the well profiles could be stored locally, the WITSML files provided locally for quick retrieval, and the data uploaded into the reservoir management system. Modbus output provided basic system alarms linked directly to the local control room to help ensure asset integrity.

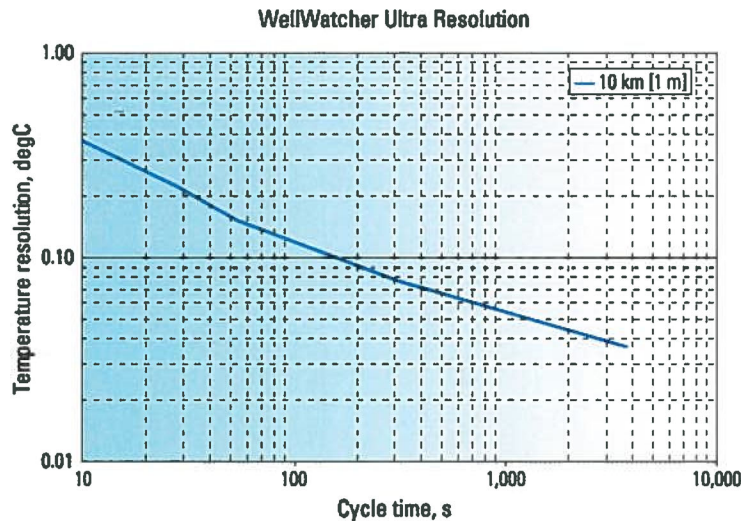

The log/log metrology plot shows the time required for a typical WellWatcher Ultra DTS acquisition unit out of calibration to reach certain temperature resolutions for 10 km of fiber. Additional optimization is possible to further improve results, depending on the application requirements.

Specifications

| | |
|------------------------------------|--|
| Range, km [mi] | 15 [9.32] |
| Spatial resolution, m [ft] | 1–4 [3.3–13.1] |
| Sample interval, m [ft] | 0.5–2 [1.64–6.56] |
| Calibration accuracy, degC [degF] | ±0.5 [±0.9] at (0–8 km); ±1 [±1.8] at (8–12 km) |
| Number of loops or fibers | 6 double-ended or 12 single-ended |
| Fiber type | 50 µm, multimode |
| DTS physical dimensions | 3U 19-in, rack mounted or mobile |
| Operating temperature, degC [degF] | 0 to 40 [32 to 104] |
| Storage temperature, degC [degF] | –20 to 65 [–4 to 149] |
| Relative humidity, % | 5–85 (noncondensing) |
| Power | AC, 90–253 V (optional DC, 24 V); Typical steady state: 50 W; maximum: 150 W |
| DTS communications | |
| DTS to PC | Ethernet 100/1000 Base T |
| DTS to Modbus PLC | Ethernet 10/100 Base T |
| Relay contact: 32 per box | RS485 |
| Laser classification | Class 1m, (IEC/EN 60825-1 [2001]) |

www.slb.com/completions

Schlumberger

WellWatcher Quartz

NLQG, NMQG, NPQG, NHQG multidrop pressure and temperature gauges

APPLICATIONS

- Long-term production and reservoir monitoring
- Pressure buildup surveys
- Injection monitoring
- Intelligent completions

BENEFITS

- Saves costs of well intervention by taking continuous pressure and temperature measurements

FEATURES

- Long-term measurement accuracy with excellent sensor and electronic stability
- High system reliability confirmed by rigorous testing
- Long-term, reliable, permanent in-well reservoir monitoring
- Compact gauge design for optimal well integration
- Gauge system with advanced cable connector technology
- Multiple-gauge installation on a single cable with standard 1-s sampling rate
- Compatibility with the WellWatcher Neon[®] electro-optical cable system for combined distributed temperature-sensing measurements
- Flow rate and fluid density measurements in specific applications
- Hermetically sealed gauge housing, fully welded with inert gas filling
- Availability of IWIS-compliant and vendor-specific subsea cards

WellWatcher Quartz[®] NLQG, NMQG, NPQG, and NHQG multidrop pressure and temperature gauges are part of the WellWatcher[®] permanent real-time downhole monitoring system. WellWatcher systems help operators optimize well productivity and reservoir recovery throughout the producing life of a well or field.

Schlumberger has installed more than 7,000 permanent downhole pressure and temperature gauges over the past 25 years and has established numerous engineering and performance benchmarks for downhole monitoring. Continual performance improvement has yielded the most reliable track record in the industry for these types of gauges.

The latest-generation Schlumberger permanent WellWatcher Quartz gauges continue this tradition and incorporate the most recent innovations in quartz transducers, advanced electronic components, and cable head connector sealing technology.

DATA QUALITY

Accurate and stable pressure measurements are essential in long-term reservoir and production monitoring applications. Schlumberger permanent WellWatcher Quartz gauges are engineered to deliver highly stable pressure measurements for long-term applications.

Performance is validated in a controlled test cell where drift stability is measured at simulated reservoir pressure and temperature conditions—not just at ambient temperature and atmospheric conditions.

During this measurement period, the gauges are also subjected to power on-off cycles and temperature cycling to simulate the most demanding operating conditions. The NPQG gauge is qualified for a 10-year life cycle and has a measured drift stability better than ± 7 kPa at 82,740 kPa and 150 degC (± 1 psi at 12,000 psi and 302 degF).

QUALIFICATION TESTING

The gauge system undergoes accelerated testing at 200 degC (392 degF) for about 8 months, in addition to thermal shock cycle testing. This test is equivalent to a 10-year life at 150 degC (302 degF). The complete gauge assemblies also undergo repeated shock and vibration testing at rigorous levels to meet the environmental qualification for well testing in production and injection wells.

DESIGNED FOR RELIABILITY

The long-term reliability of the WellWatcher Quartz gauges relies on designs including fully welded assemblies, multichip module ceramic high-temperature electronic technology, and corrosion-resistant alloys.

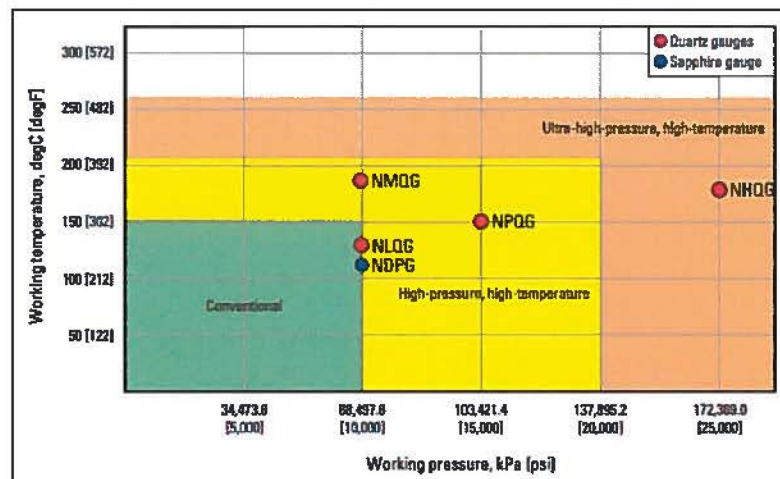

Temperature and pressure environmental applications in which WellWatcher Quartz and WellWatcher Sapphire[®] gauges are most appropriate.

WellWatcher Quartz

Also furthering the gauge technology is the excellent reliability at system level achieved with the Schlumberger proprietary advanced connector technology.

The standard NMQG (68,947 kPa [10,000 psi]), NPQG (110,320 kPa [16,000 psi]), and NHQG (172,375 kPa [25,000 psi]) gauges feature the innovative and fully field-proven Intellitite® electrical dry-mate cable head connector options. The welded cable head, which can be deployed even in Zone 1, delivers the best system protection against corrosive liquids, shock, vibration, and tensile load. The nonwelded cable head provides three independent seals, including two fully redundant metal-to-metal seals, and is fully pressure testable using a microleak detection system. Both cable head connector options deliver significant reliability improvement over industry-standard connectors.

The standard NMQG (10,000-psi) gauge is equipped with the Sealtite® connector, providing two independent seals, including an improved metal-to-metal seal. When dictated by demanding downhole conditions such as sour fluids or below-packer applications, the gauge is equipped with the Intellitite electrical dry-mate connector for an incremental level of reliability.

WORLDWIDE QUALITY SERVICE

WellWatcher systems are supported and deployed by a specialized group of engineers and technicians highly trained on permanent monitoring systems and intelligent completion technology. This specific central support for project preparation and operations contributes to delivering best-in-class service quality worldwide.

WellWatcher Quartz Gauge Specifications

| | NMQG Light Quartz Gauge | NMQG Median Quartz Gauge | NPQG Pressure Quartz Gauge | NHQG Hyper Quartz Gauge |
|---|--|---|--|--|
| Sensor metrological performance | | | | |
| Sensor type | Quartz | Quartz | Quartz | Quartz |
| Calibrated working pressure range, kPa [psi] | Atmospheric to 68,947 [10,000] | Atmospheric to 68,947 [10,000] | Atmospheric to 110,320 [16,000] | Atmospheric to 172,375 [25,000] |
| Calibrated working temperature range, degC [degF] | 25 to 130 [77 to 266] | 25 to 177 [68 to 350] | 25 to 150 [68 to 302] | 25 to 177 [68 to 350] |
| Other calibrated ranges ¹ | Available upon request | Available upon request | Available upon request | Available upon request |
| Initial pressure accuracy, kPa [psi] | <±13.8 [±2] max. over full scale | <±13.8 [±2] max. over full scale | <±20.7 [±3] max. over full scale | <±34.5 [±5] max. over full scale |
| Pressure resolution, kPa [psi] | 0.03 [0.005] at 1-s sample rate | 0.03 [0.005] at 1-s sample rate | 0.07 [0.01] at 1-s sample rate | 0.14 [0.02] at 1-s sample rate |
| Pressure drift stability, kPa [psi] | <± 6.9 [±1] per year over full scale | <± 6.9 [±1] per year over full scale | <±8.9 [±1] per year at 82,740 kPa [12,000 psi] and 150 degC [302 degF] | <±6.9 [±1] per year at 82,740 kPa [12,000 psi] and 150 degC [302 degF] |
| Initial temperature accuracy, max., degC [degF]/typical degC [degF] | <±0.5 [±0.9] per ±0.15 [±0.27] | <±0.5 [±0.9] per ±0.15 [±0.27] | <±0.5 [±0.9] per ±0.15 [±0.27] | <±0.5 [±0.9] per ±0.15 [±0.27] |
| Temperature resolution, degC [degF] | 0.005 [0.009] at 1-s sample rate | 0.001 [0.002] at 1-s sample rate | 0.001 [0.002] at 1-s sample rate | 0.001 [0.002] at 1-s sample rate |
| Temperature drift stability, degC [degF] | <±0.1 [±0.18] per year at 150 [302] | <±0.1 [±0.18] per year at 177 [350] | <±0.1 [±0.18] per year at 150 [302] | <±0.1 [±0.18] per year at 177 [350] |
| Max. overtemperature, degC [degF] | 150 [302] | 200 [392] | 200 [392] | 200 [392] |
| Physical characteristics | | | | |
| Max. housing diameter, mm [in] | 19 [0.75] | 19 [0.75] | 19 [0.75] | 19 [0.75] |
| Cable head connector options | | | | |
| Intellitite R: true redundant metal/metal seal | Special request | Yes | Yes | Yes |
| Intellitite W: fully welded | na ² | Yes | Yes | Yes |
| Sealtite: metal/metal seal | Yes | na | na | na |
| Multigauge connections options | Fully welded Y, T, and W connector block assembly | Fully welded Y, T, and W connector block assembly | Fully welded Y, T, and W gauge assembly | Fully welded Y, T, and W gauge assembly |
| Gauge pressure port reading options | Tubing measurement, annulus measurement, measurement through control line by HDMC hydraulic connector, and flowmeter application | | | |
| Material | Corrosion-resistant alloys per ISO 15156 [with Intellitite connector option] | Corrosion-resistant alloys per ISO 15156 | Corrosion-resistant alloys per ISO 15156 | Corrosion-resistant alloys per ISO 15156 |
| Service | H ₂ S [with Intellitite connector option] | H ₂ S | H ₂ S | H ₂ S |
| Collapse pressure, kPa [psi] | 75,842 [11,000] | 75,842 [11,000] | 137,900 [20,000] | 189,613 [27,500] |
| Storage and shipping temperature, degC [degF] | -40 to 75 [-40 to 167] | -40 to 75 [-40 to 167] | -40 to 75 [-40 to 167] | -40 to 75 [-40 to 167] |
| Well integration | | | | |
| Max. number of gauges per single cable ³ | 4 at 1-s sampling rate | | | |
| Max. cable length, m [ft] | 10,000 [32,800] | | | |
| Max. distance between gauges, m [ft] | 1,000 [3,281] | | | |
| Qualification test data | | | | |
| Long-term qualification test equivalent life cycle | 10 years at 82,740 kPa [12,000 psi] and 150 degC [302 degF] | | | |
| Vibration | 10 to 2,000 Hz at up to 4 g in any axis | | | |
| Shock | 400 impacts at 250 g [2-ms half sine, 4 axis] and 6 drop impacts at 500 g [2-ms half sine, 6 axis] | | | |

¹ A lower temperature calibration may be required for injection wells.

² Not applicable.

³ Consult a Schlumberger representative for additional specifications.

www.slb.com/completions

Schlumberger

APPENDIX B. Log Quality Control Reference Manual (LQCRM)

Wireline Log Quality Control Reference Manual



**Wireline Log
Quality Control
Reference Manual**

Schlumberger
3750 Briarpark Drive
Houston, Texas 77042

www.slb.com

Produced by Schlumberger Oilfield Marketing Communications

Copyright © 2012 Schlumberger. All rights reserved.

No part of this book may be reproduced, stored in a retrieval system, or transcribed in any form or by any means, electronic or mechanical, including photocopying and recording, without the prior written permission of the publisher.

While the information presented herein is believed to be accurate, it is provided "as is" without express or implied warranty.

11-FE-0131

An asterisk (*) is used throughout this document to denote a mark of Schlumberger. Other company, product, and service names are the properties of their respective owners.

Contents

| | |
|--|-----|
| Foreword | 1 |
| Introduction | 2 |
| Depth Control and Measurement | 5 |
| Logging Platforms and Suites | 13 |
| Platform Express* integrated wireline logging tool | 13 |
| PS Platform* production services platform | 23 |
| Dielectric Scanner | 24 |
| Dielectric Scanner* multifrequency dielectric dispersion service | 24 |
| EPT* electromagnetic propagation tool | 29 |
| Resistivity Logging | 32 |
| Rt Scanner* triaxial induction service | 32 |
| AIT* array induction imager tool | 41 |
| ARI* azimuthal resistivity imager | 47 |
| HRLA* high-resolution laterolog array | 50 |
| High-Resolution Azimuthal Laterolog Sonde | 55 |
| MicroSFL* spherically focused resistivity tool | 60 |
| Microlog | 62 |
| CHFR-Plus* and CHFR Slim* cased hole formation resistivity tools | 64 |
| Nuclear Measurements | 67 |
| Gamma Ray Tools | 67 |
| NGS* natural gamma ray spectrometry tool | 69 |
| Hostile Environment Natural Gamma Ray Sonde | 71 |
| ECS* elemental capture spectroscopy sonde | 74 |
| CNL* compensated neutron log | 81 |
| APS* accelerator porosity sonde | 84 |
| RST* and RSTPro* reservoir saturation tools | 87 |
| Litho-Density* photoelectric density log | 92 |
| Litho-Density Sonde | 94 |
| HLDT* hostile environment Litho-Density tool | 97 |
| SlimXtreme* LithoDensity tool | 100 |
| Nuclear Magnetic Resonance Logging | 103 |
| MR Scanner* expert magnetic resonance service | 103 |
| CMR-Plus* combinable magnetic resonance tool | 107 |
| Acoustic Logging | 112 |
| Sonic Scanner* acoustic scanning platform | 112 |
| Borehole-Compensated Sonic | 117 |
| Sonic Long Spacing | 121 |
| DSI* dipole shear sonic imager | 124 |

| | |
|--|-----|
| Dipmeter and Imaging Services | 129 |
| FMI* fullbore formation microimager | 129 |
| FMI-HD* high-definition formation microimager | 132 |
| UBI* ultrasonic borehole imager | 135 |
| OBMI* oil-base microimager | 139 |
| Drilling and Directional Services | 142 |
| GPIT* General Purpose Inclination Tool | 142 |
| Seismic Imaging Tools and Services | 145 |
| CSI* combinable seismic imager | 145 |
| VSI* versatile seismic imager | 148 |
| Formation Testing and Sampling | 154 |
| MDT* modular formation dynamics tester | 154 |
| Quicksilver Probe* focused extraction of pure reservoir fluid | 159 |
| InSitu Fluid Analyzer* real-time quantitative reservoir fluid measurements | 163 |
| MDT Dual-Packer Module | 169 |
| MDT Dual-Probe Module | 172 |
| MDT Pumpout Module | 175 |
| LFA* live fluid analyzer | 177 |
| CFA* composition fluid analyzer | 181 |
| MDT Multisample Module | 184 |
| PressureXpress* reservoir pressure while logging service | 186 |
| SRFT* slimhole repeat formation tester | 190 |
| CHDT* cased hole dynamics tester | 194 |
| MSCT* mechanical sidewall coring tool | 198 |
| CST* chronological sample taker | 200 |
| Well Integrity Evaluation | 203 |
| Isolation Scanner* cement evaluation service | 203 |
| Cement bond tool | 208 |
| Cement bond logging with Slim Array Sonic Tool, Digital Sonic Logging Tool, and SlimXtreme tool | 212 |
| Sonic Scanner* acoustic scanning platform | 215 |
| SCMT* slim cement mapping tool | 218 |
| USI* ultrasonic imager | 222 |
| UCI* ultrasonic casing imager | 225 |
| METT* multifrequency electromagnetic thickness tool | 228 |
| Multifinger Caliper Tool | 230 |
| PS Platform Multifinger Imaging Tool | 232 |
| Production Logging Services | 235 |
| Flow Scanner* horizontal and deviated well production logging system | 235 |
| PS Platform production services platform | 239 |
| Platform Basic Measurement Sonde | 240 |
| Gradiomanometer* sonde | 241 |
| PS Platform Inline Spinner | 243 |
| Flow-Caliper Imaging Sonde | 244 |

| | |
|---|-----|
| Digital Entry and Fluid Imager Tool | 246 |
| GHOST* gas holdup optical sensor tool | 247 |
| RST and RSTPro reservoir saturation tools | 249 |
| WFL* water flow log | 254 |
| TPHL* three-phase fluid production log | 256 |
| CPLT* combinable production logging tool | 258 |
| Perforating Services and Accessories | 263 |
| Perforating depth control | 263 |
| Plugs and Packers | 265 |
| PosiSet* mechanical plugback tool | 265 |
| Auxiliary Measurements and Devices | 267 |
| Borehole geometry log | 267 |
| Powered Positioning Device and Caliper | 269 |
| Auxiliary Measurement Sonde | 271 |
| Environmental Measurement Sonde | 273 |
| FPIT* free-point indicator tool | 275 |
| TDT* thermal decay time | 277 |

Foreword

The certification of acquired data is an important aspect of logging. It is performed through the observation of quality indicators and can be completed successfully only when a set of specified requirements is available to the log users.

This Log Quality Control Reference Manual (LQCRM) is the third edition of the log quality control specifications used by Schlumberger. It concisely provides information for the acquisition of high-quality data at the wellsite and its delivery within defined standards. The LQCRM is distributed to facilitate the validation of Schlumberger wireline logs at the wellsite or in the office.

Because the measurements are performed downhole in an environment that cannot be exhaustively described, Schlumberger cannot and does not warrant the accuracy, correctness, or completeness of log data.

Large variations in well conditions require flexibility in logging procedures. In some cases, important deviations from the guidelines given here may occur. These deviations may not affect the validity of the data collected, but they could reduce the ability to check that validity.

Catherine MacGregor
President, Wireline

Introduction

Data is a permanent asset of energy companies that may be used in unforeseen ways. Schlumberger is committed to and accountable for managing and delivering quality data. The quality of the data is the cornerstone of Schlumberger products and services.

Data quality

Quality is conformance to predefined standards with minimum variation. This document defines the standards by which the quality of the data of Schlumberger wireline logs is determined. The attributes that form the data quality model are

- accuracy
- repeatability
- integrity
- traceability
- timeliness
- relevance
- completeness
- sufficiency
- interpretability
- reputation
- objectivity
- clarity
- availability
- accessibility
- security.

Accuracy

Accuracy is how close to the true value the data is within a specified degree of conformity (e.g., metrology and integrity). Accuracy is a function of the sensor design; the measurement cannot be made more accurate by varying operating techniques, but it can fail to conform to the defined accuracy as a result of several errors (e.g., incorrect calibration).

Repeatability

Repeatability of data is the consistency of two or more data products acquired or processed using the same system under the same conditions. Reproducibility, on the other hand, is the data consistency of two

or more data products acquired or processed using different systems or under different conditions. The majority of wireline measurements have a defined repeatability range, which is applicable only when the measurement is conducted under the same conditions. Repeatability is used to validate the measurement acquired during the main logging pass, as well as identify anomalies that may arise during the survey for relogging.

Integrity

The integrity of data is essential for the believability of data. Data with integrity is not altered or tampered with. There are situations in which data is altered in a perfectly acceptable manner (e.g., applying environmental corrections, using processing parameters for interpretation). Any such changes, which involve an element of judgment, are not done to intentionally produce results inconsistent with the measurements or processed data and are to the best and unbiased judgment of the interpreter. Results of interpretation activities are auditable, clearly marked, and traceable.

Traceability

Traceability of data refers to having a complete chain defining a measurement from its point of origin (sensor) to its final destination (formation property). At each step of the chain, appropriate measurement standards are respected, well documented, and auditable.

Timeliness

Timeliness is the availability of the data at the time required. Timeliness ensures that all tasks in the process of acquiring data are conducted within the time window defined for such tasks (e.g., wellsite calibrations and checks are done within the time window defined).

Relevance

Relevance is the applicability and helpfulness of the acquired dataset within the business context (e.g., selection of the right service for the well conditions). Most services have a defined operating envelope in which the measurement is considered valid. Measurements conducted outside their defined envelope, although the measurement process may have been completed satisfactorily, are almost always irrelevant (e.g., recording an SP curve in an oil-base mud environment).

Completeness

Completeness ensures that the data is of sufficient breadth, depth, and scope to meet predefined requirements. This primarily means that all required measurements are available over the required logging interval, with no missing curves or gaps in curves over predefined required intervals of the log.

Sufficiency

Sufficiency ensures that the amount of data that is acquired or processed meets the defined objectives of the operation. For example, when the defined objective is to compute the hole volume of an oval hole, a four-arm caliper service—at minimum—must be used. Using a single-arm caliper service would not provide sufficient information to achieve the defined objective and would inadvertently result in over-estimation of the hole volume.

Interpretability

Interpretability of data requires that the measurement is specified in appropriate terminology and units and that the data definitions are clear and documented. This is essential to ensure the capability of using the data over time (i.e., reusability).

Reputation

Reputation refers to data being trusted or highly regarded in terms of its source, content, and traceability.

Objectivity

The objectivity of data is an essential attribute of its quality, unbiased and impartial, both at acquisition and at reuse.

Clarity

Clarity refers to the availability of a clear, unique definition of the data by using a controlled data dictionary that is shared. For example, when “NPHI” is referred to, it must be understood by all that NPHI is the thermal neutron porosity in porosity units (m^3/m^3 or ft^3/ft^3), computed from a thermal neutron ratio that is calibrated using a single-point calibration mechanism (gain only), and is the ratio of counts from a near and a far receiver, with the counts corrected only for hole size and not corrected for detector dead time.

Clarity ensures objectivity and interpretability over time.

Availability

Availability of data ensures the distribution of data only to the intended parties at the requested time (i.e., no data is disclosed to any other party than the owner of the data without prior written permission).

Accessibility

Accessibility ensures the ease of retrievability of data using a classification model. Wireline data are classified into three datasets:

- Basic dataset is a limited dataset suitable for quicklook interpretation and transmission of data.
- Customer dataset consists of a complete set of data suitable for processing (measurements with their associated calibrations), recomputing (raw curves), and validating (log quality control [LQC] curves) the measurements of the final product delivered. The customer dataset includes all measurements required to fully reproduce the data product with a complete and auditable traceability chain.
- Producer dataset includes Schlumberger-proprietary data, which are meaningful only to the engineering group that supports the tool in question (e.g., the 15th status bit of ADC015 on board EDCIB023 in an assembly).

Security

The security of data is essential to maintain its confidentiality and ensure that data files are clean of malware or viruses.

Calibration theory

The calibration of sensors is an integral part of metrology, the science of measurement. For most measurements, one of the following types of calibrations is employed:

- single-point calibration
- two-point calibration
- multiple-point calibration.

Because most measurements operate in a region of linear response, any two points on the response line can be compared with their associated calibration references to determine a gain and an offset (two-point calibration) or a gain (single-point calibration). The gain and offset values are used in the calibration value equation, which converts any measured value to its associated calibrated value.

There are three events that measurements may have one or more of:

- **Master calibration:** Performed at the shop on a quarterly or monthly basis, a master calibration usually comprises a primary measurement done to a measurement standard and a reference measurement that serves as a baseline for future checks. The primary measurement is the calibration of the sensor used for converting a raw measurement into its final output.
- **Wellsite before-survey calibration or check:** Measurements that have a master calibration are normally not calibrated at the wellsite; rather, the reference measurement conducted in the master calibration is repeated at the wellsite before conducting the survey to ensure that the tool response has not changed. Measurements that do not have a master calibration may employ a wellsite calibration that is conducted prior to starting the survey.
- **Wellsite after-survey check:** Some measurements employ an after-survey check (optional for most measurements) to ensure that the tool response has not changed from before the survey.

All such events are recorded in a calibration summary listing (CSL) (Fig. 1).

The calibration summary listing contains an auditable trail of the event:

- equipment with serial numbers
- actual measurement and the associated range (minimum, nominal, and maximum)
- time the event was conducted.

For the event to be valid, the measurement must fall within the defined minimum and maximum limits, using the same equipment (verified through the mnemonics and serial numbers), and performed on time (verified through the time stamp on the summary listing).

More details on the calibrations associated with the wide range of Schlumberger wireline measurements are in the *Logging Calibration Guide*, which is available through your local Schlumberger representative.

| Hostile Natural Gamma Ray Sonde / Equipment Identification | | | |
|--|--------------------------|--|-----------|
| Primary Equipment: | HNGS Sonde | | HNGS - BA |
| Auxiliary Equipment: | HNGS Sonde Housing | | HNSH - BA |
| | Gamma Source Radioactive | | GSR - U |

| Hostile Natural Gamma Ray Sonde Master Calibration | | | | | | | | | |
|--|---------------------------|--------------------|--------------------|-------|--------|---------------------|--------------------|--------------------|--------|
| Detector 1 Calibration | | | | | | | | | |
| Phase | Na 511 Peak Set Point | | | Value | Phase | Th Peak Loc | | | Value |
| Master | | | | 42.00 | Master | | | | 211.9 |
| | 38.00 (Minimum) | 40.00 (Nominal) | 42.00 (Maximum) | | | 201.0 (Minimum) | 209.6 (Nominal) | 218.3 (Maximum) | |
| Phase | Background Count Rate CPS | | | Value | Phase | Gain Ratio | | | Value |
| Master | | | | 96.67 | Master | | | | 0.9936 |
| | 20.00 (Minimum) | 142.5 (Nominal) | 265.0 (Maximum) | | | 0.9400 (Minimum) | 1.000 (Nominal) | 1.060 (Maximum) | |
| Master: | | | | | | | | | |

| Hostile Natural Gamma Ray Sonde Master Calibration | | | | | | | | | |
|--|---------------------------|--------------------|--------------------|-------|--------|---------------------|--------------------|--------------------|-------|
| Detector 2 Calibration | | | | | | | | | |
| Phase | Na 511 Peak Set Point | | | Value | Phase | Th Peak Loc | | | Value |
| Master | | | | 41.00 | Master | | | | 211.1 |
| | 38.00 (Minimum) | 40.00 (Nominal) | 42.00 (Maximum) | | | 201.0 (Minimum) | 209.6 (Nominal) | 218.3 (Maximum) | |
| Phase | Background Count Rate CPS | | | Value | Phase | Gain Ratio | | | Value |
| Master | | | | 96.01 | Master | | | | 1.017 |
| | 20.00 (Minimum) | 142.5 (Nominal) | 265.0 (Maximum) | | | 0.9400 (Minimum) | 1.000 (Nominal) | 1.060 (Maximum) | |
| Master: | | | | | | | | | |

Figure 1. Example of a master calibration.

Depth Control and Measurement

Overview

Depth is the most fundamental wireline measurement made; therefore, it is the most important logging parameter. Because all wireline measurements are referenced to depth, it is absolutely critical that depth is measured in a systematic way, with an auditable record to ensure traceability.

Schlumberger provides through its wireline services an absolute depth measurement and techniques to apply environmental corrections to the measurement that meet industry requirements for subsurface marker referencing.

The conveyance of tools and equipment by means of a cable enables the determination of an absolute wellbore depth under reasonable hole conditions through the strict application of wellsite procedures and the implementation of systematic maintenance and calibration programs for measurement devices. The essentials of the wireline depth measurement are the following:

- Depth is measured from a fixed datum, termed the depth reference point, which is specified by the client.
- The Integrated Depth Wheel (IDW) device (Fig. 1) provides the primary depth measurement, with the down log taken as the correct depth reference.
- Slippage in the IDW wheels is detected and automatically compensated for by the surface acquisition system.
- The change in elastic stretch of the cable resulting from changing direction at the bottom log interval is measured and applied to the log depth as a delta-stretch correction.
- Other physical effects on the cable in the borehole, including changes in length owing to wellbore profile, temperature, and other hole conditions, are not measured but can be corrected for after logging is complete.
- Subsequent logs that do not require a primary depth measurement are correlated to a reference log specified by the client, provided that enough information exists to validate the correctness of the depth measured on previous logs.
- Traceability of the corrections applied should be such that recovery of absolute depth measurements is possible after logging, if required.

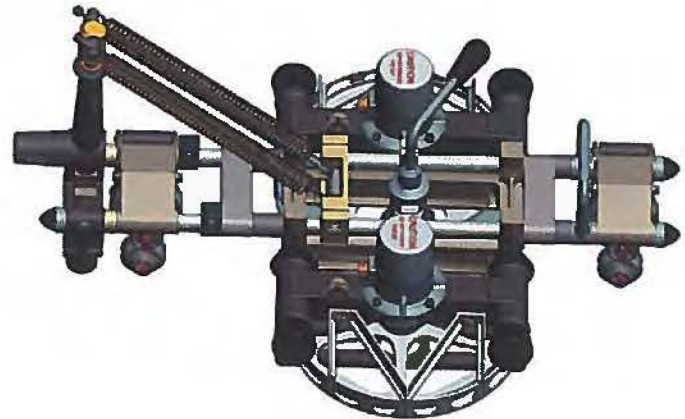

Figure 1. Integrated Depth Wheel device.

By strict application of this procedure, Schlumberger endeavors to deliver depth measurement with an accuracy of ± 5 ft per 10,000 ft and repeatability of ± 2 ft per 10,000 ft [± 1.5 m and ± 0.6 m per 3,050 m, respectively] in vertical wells.

Specifications

| Measurement Specifications | |
|----------------------------|---|
| Accuracy | ± 5 ft per 10,000 ft [± 1.5 m per 3,050 m] |
| Repeatability | ± 2 ft per 10,000 ft [± 0.6 m per 3,050 m] |

Calibration

The IDW calibration must be performed every 6 months, after 50 well-site trips, or after 500,000 ft [152,400 m] have passed over the wheel, whichever comes first. The IDW device is calibrated with a setup that is factory-calibrated with a laser system, which provides traceability to international length standards.

Tension devices are calibrated every 6 months for each specific cable by using a load cell.

For more information, refer to the *Logging Calibration Guide*, which is available through your local Schlumberger representative.

The high-precision IDW device uses two wheels that measure cable motion at the wireline unit. Each wheel is equipped with an encoder, which generates an event for every 0.1 in [0.25 cm] of cable travel. A wheel correction is applied to obtain the ideal of one pulse per 0.1 in of cable travel.

Integration of the pulses results in the overall measured depth, which is the distance measured along the actual course of the borehole from the surface reference point to a point below the surface.

A tension device, commonly mounted on the cable near the IDW device, measures the line tension of the cable at the surface.

Depth control procedure

On arrival at the wellsite, the wireline crew obtains all available information concerning the well and the depth references (wellsite data) from the client's representative. Information related to the calibrations of the IDW device and the tension device is entered in the surface acquisition system.

First trip

First log

The procedure for the first log in a well consists of the following major steps:

1. Set up the depth system, and ensure that wheel corrections are properly set for each encoder.
2. Set tool zero (Fig. 2) with respect to the client's depth reference.
3. Measure the rig-up length (Fig. 3) between the IDW device and the rotary table at the surface. Investigate, and correct as necessary, any significant change in the rig-up length from that measured with the tool close to the surface.
4. Run in the hole with the toolstring.
5. Measure the rig-up length (Fig. 3) between the IDW device and the rotary table at bottom.
6. Correct for the change in elastic stretch resulting from the change in cable or tool friction when logging up.
7. Record the main log.
8. Record one or more repeat sections for repeatability analysis.[†]
9. Pull the toolstring out of the hole and check the depth on return to surface.

To set tool zero on a land rig, fixed platform, or jackup, the toolstring is lowered a few feet into the hole and then pulled up, stopping when the tool reference is at the client's depth reference point (Fig. 2).



Figure 2. Tool zero.

[†]Operational considerations may dictate a change in the order of Steps 6–8.

The following procedure for setting tool zero is used on floating vessels, semisubmersible rigs, and drillships equipped with a wave motion compensator (WMC):

1. With the WMC deactivated, stop the tool reference at the rotary table, and set the system depth to zero.
2. Lower the tool until the logging head is well below the riser slip joint, then flag the cable at the rotary table and record the current depth.
3. Have the driller pull up slowly on the elevators, until the WMC is stroking about its midpoint.
4. Raise or lower the tool until the cable flag is back at the rotary table.
5. Set the system depth to the depth recorded in Step 2.

Measuring the cable rig-up length ensures that the setup has not changed while running in the well (e.g., slack in the logging cable, movement of the logging unit, the blocks, or the sheaves). The following procedure is used to measure the rig-up length of the cable (Fig. 3):

1. Run in the hole about 100 ft [30 m], flag the cable at the IDW device, and note the depth.
2. Lower the toolstring until the flag is at the rotary table. Subtract the depth recorded in Step 1 from the current depth. The result is the rig-up length at surface (RULS).
3. Record RULS.

The speed used to proceed in the hole should avoid tool float (caused by excessive force owing to mud viscosity acting on the tool) or birdcaging of the cable. To the extent possible and operational considerations permitting, a constant speed should be maintained while running downhole. At the bottom of the hole, the measurement process is conducted to obtain the rig-up length at bottom (RULB), which is also recorded. If RULB differs from RULS by more than 1 ft [0.3 m], the rig-up has changed and the cause of the discrepancy must be investigated and eliminated or corrected for.

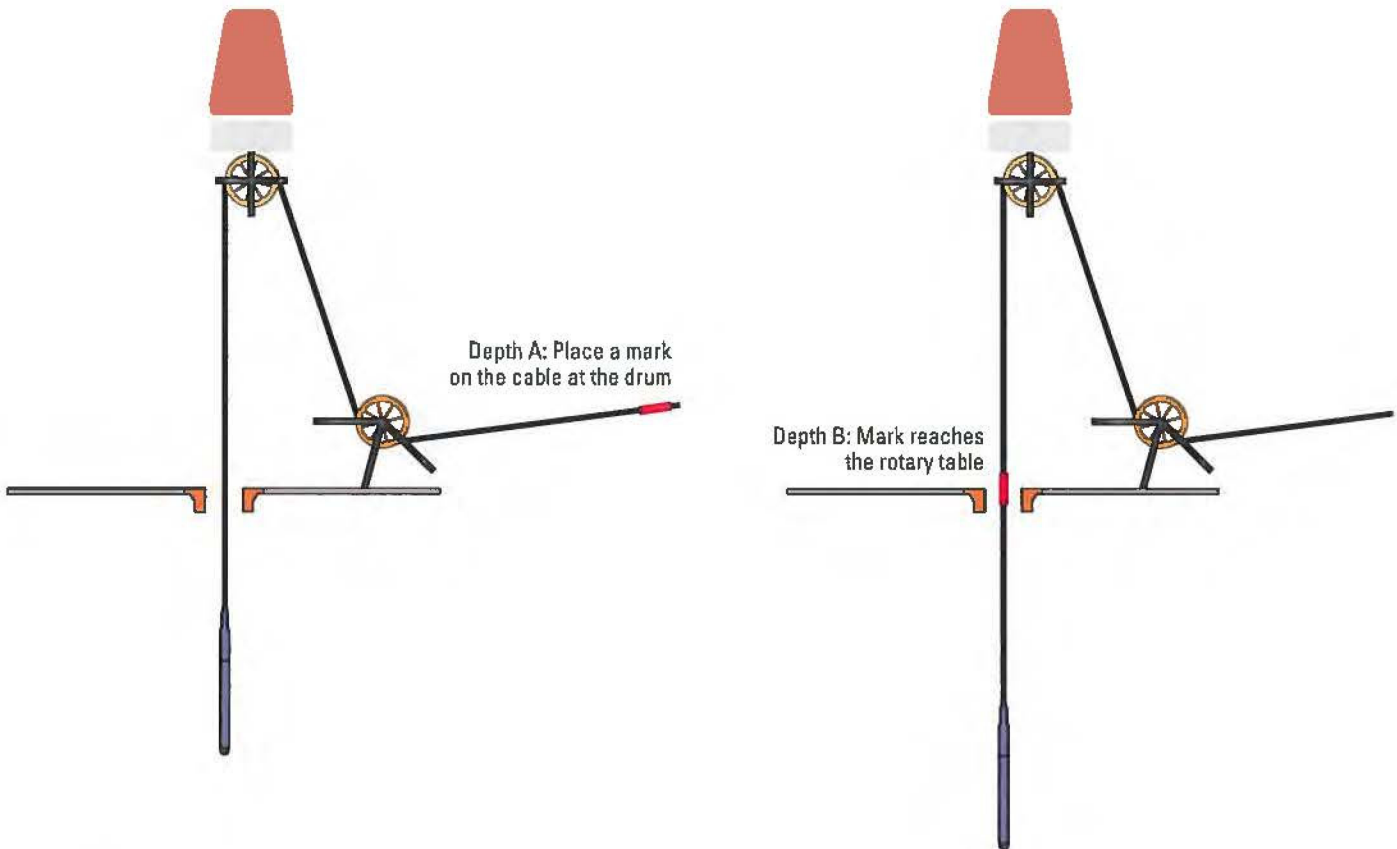

Figure 3. Rig-up length measurement procedure.

The rig-up length correction ($RULC = RULS - RULB$) is applied by adding RULC to the system depth. RULC is recorded in the Depth Summary Listing (Fig. 5).

To correct for the change of elastic stretch, the log-down/log-up method (Fig. 4) is applied as close as is reasonable to the bottom log interval:

1. Continue toward the bottom of the well at normal speed.
2. Log down a short section (minimum 200 ft [60 m]) close to the bottom, making sure to include distinctive formation characteristics for correlation purposes.
3. At the bottom, open calipers (if applicable) and log up a section overlapping the down log obtained in Step 2.
4. Using the down log as a reference, adjust the up-log depth to match the down log.

5. The adjustment is the stretch correction (SCORR) resulting from the change in tension. SCORR should be added to the hardware depth before logging the main pass.
6. Record SCORR and the depth at which it was determined in the Depth Summary Listing (Fig. 5).

If it is determined to be too risky to apply the delta-stretch correction before starting the log, the log can be recorded with no correction and then depth-shifted after the event with a playback. This procedure must be documented clearly in the Depth Summary Listing remarks. Such a procedure is justified when the well is excessively hot or sticky, and following the steps previously outlined could lead to a significant risk of tool problems or failure to return to bottom (and thus to loss of data).

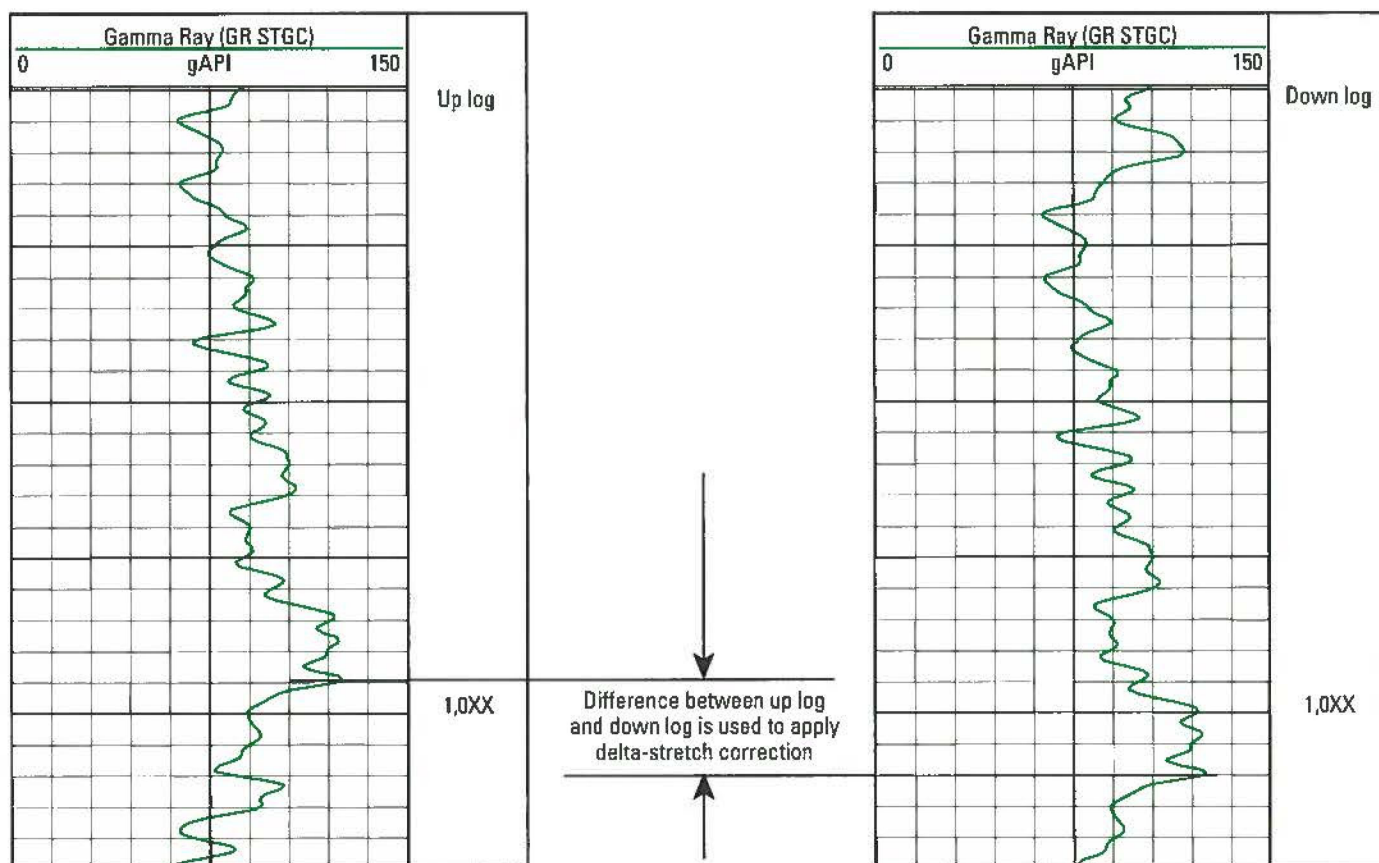

Figure 4. Stretch correction.

After pulling out of the hole, tool zero is checked at the surface, as was done before running in the hole, and the difference is recorded in the Depth Summary Listing (Fig. 5). In deviated wells in particular, environmental effects may lead to a re-zero error, with the depth system reading other than zero when the tool reference is positioned opposite the log reference point after return to the surface. Recording this difference is an essential step in controlling the quality of any depth

correction computed after the log, because that depth correction process should include an estimate of the expected re-zero error.

All information related to the procedure followed for depth control should be recorded in the Depth Summary Listing (Fig. 5) for future reference.

| DEPTH SUMMARY LISTING | | |
|---|---|--|
| Date Created: 10-Dec-20XX 12:09:15 | | |
| Depth System Equipment | | |
| Depth Measuring Device | Tension Device | Logging Cable |
| Type : IDW-B Serial Number: 4XX Calibration Date: 10-Dec-20XX Calibrator Serial Number: 15XX Calibration Cable Type: 7-46P Wheel Correction 1: -3 Wheel Correction 2: -2 | Type : CMTD-B/A Serial Number: 82XXX Calibration Date: 10-Dec-20XX Calibrator Serial Number: 98XX Number of Calibration Points: 10 Calibration RMS: 11 Calibration Peak Error: 15 | Type : 7-46P Serial Number: 83XX Length: 18750 FT Conveyance Method: Wireline Rig Type: LAND |
| Depth Control Parameters | | |
| Log Sequence: | First Log in the Well | |
| Rig Up Length At Surface: | 352.00 FT | |
| Rig Up Length At Bottom: | 351.00 FT | |
| Rig Up Length Correction: | 1.00 FT | |
| Stretch Correction: | 5.00 FT | |
| Tool Zero Check At Surface: | 0.50 FT | |
| Depth Control Remarks | | |
| <ol style="list-style-type: none"> 1. Subsequent trip to the well. Downlog correlated to reference log XXX by YYY company dated DD-MM-YYYY. 2. Non-Schlumberger reference log. Full 1st trip to the well depth control procedure applied, which required the addition of XX ft to the down log. 3. Delta-stretch correction was conducted at 12XXX ft and applied to depth prior to recording the main log. 4. Z-chart used as a secondary depth check. | | |

Figure 5. Depth Summary Listing for the first trip, first log in the well.

Subsequent logs

The depth of subsequent logs on the same trip is tied into the first log using the following procedure:

1. Properly zero the tool as for the first log.
2. The rig-up length does not need to be measured if the setup has not changed since the previous log.
3. Match depths with the first log by using a short up-log pass.
4. Run the main log and repeat passes as necessary.
5. Record the re-zero error in the Depth Summary Listing. This is part of the traceability that makes possible the determination of absolute depth after the event, if required.

Subsequent logs should be on depth with the first log over the complete interval logged. However, particularly when toolstrings of different

weights are run in deviated wells, the relative depths of the logs can change over long logging intervals. Subsequent correction should enable removing all discrepancies.

The amount and sign of the correction applied and the depth at which it was determined must be recorded in the Depth Summary Listing. For any down log made, the delta-stretch correction should also be recorded, as well as the depth at which it was determined.

All information related to the procedure followed for depth control of subsequent logs of the first trip should be recorded in the Depth Summary Listing (Fig. 6).

| DEPTH SUMMARY LISTING | | |
|--|---|--|
| Date Created: 10-Dec-20XX 14:38:50 | | |
| Depth System Equipment | | |
| Depth Measuring Device | Tension Device | Logging Cable |
| Type : IDW-B Serial Number: 4XX Calibration Date: 10-Dec-20XX Calibrator Serial Number: 15XX Calibration Cable Type: 7-46P Wheel Correction 1: -3 Wheel Correction 2: -2 | Type : CMTD-B/A Serial Number: 82XXX Calibration Date: 10-Dec-20XX Calibrator Serial Number: 98XX Number of Calibration Points: 10 Calibration RMS: 11 Calibration Peak Error: 15 | Type : 7-46P Serial Number: 83XX Length: 18750 FT Conveyance Method: Wireline Rig Type: LAND |
| Depth Control Parameters | | |
| Log Sequence: | Subsequent trip In the Well | |
| Reference Log Name: | AIT-GR | |
| Reference Log Run Number: | 1 | |
| Reference Log Date: | 10-Dec-20XX | |
| Depth Control Remarks | | |
| <ol style="list-style-type: none"> 1. Subsequent log on 1st trip correlated to first log in the well from XX000 to XX200 ft 2. Speed correction not applied. 3. Z-chart used as a secondary depth check. 4. Correction applied to match reference log = XX ft, determined at depth XXX00 ft. 5. No rigup changes from previous log. | | |

Figure 6. Depth Summary Listing for first trip, subsequent logs.

Subsequent trips

If there is not enough information in the Depth Summary Log from previous trips to ensure that correct depth control procedures have been applied, subsequent trips are treated as a first trip, first log in the well.

If sufficient information from previous trips was recorded to show that correct depth control procedures were applied, the previous logs can be used as a reference. The subsequent trips proceed as if running the initial trip with the following exceptions:

1. In conjunction with the client, decide which previous log to use as the downhole depth reference. Ensure that a valid copy of the reference log is available for correlation purposes. If the depth reference is a wireline log from an oilfield service provider other than Schlumberger, proceed as for the first log in the well, and investigate and document any discrepancies found with respect to the reference log.
2. Run in the hole and record a down log across an overlap section at the bottom of the reference log. If the overlap section is off by less than 5 ft per 10,000 ft, adjust the depth to match the current down

log with the reference log. This adjustment ensures that the down section of the current log is using the same depth reference as the correlation log. Record any corrections made as the subsequent trip down log correction.

3. If the overlap log is off by more than 5 ft per 10,000 ft, investigate and resolve any problems. Record any depth discrepancies. Consult with the client to decide which log to use as the depth reference.
4. Run down to the bottom of the well at a reasonable speed so that the tool does not float.
5. Log main and repeat passes, correcting for stretch following the first trip procedure.
6. The logging pass should overlap with the reference log by at least 200 ft, if possible. The depth should match the reference log. Any discrepancies should be noted in the Depth Summary Listing or the log remarks.

All information related to the depth control procedure followed should be recorded in the Depth Summary Listing (Fig. 7).

| DEPTH SUMMARY LISTING | | |
|---|---|--|
| Date Created: 10-Dec-20XX 14:26:56 | | |
| Depth System Equipment | | |
| Depth Measuring Device | Tension Device | Logging Cable |
| Type : IDW-B Serial Number: 4XX Calibration Date: 10-Dec-20XX Calibrator Serial Number: 15XX Calibration Cable Type: 7-46P Wheel Correction 1: -3 Wheel Correction 2: -2 | Type : CMTD-B/A Serial Number: 82XXX Calibration Date: 10-Dec-20XX Calibrator Serial Number: 9851 Number of Calibration Points: 10 Calibration RMS: 11 Calibration Peak Error: 15 | Type : 7-46P Serial Number: 83XX Length: 18750 FT Conveyance Method: Wireline Rig Type: LAND |
| Depth Control Parameters | | |
| Log Sequence: | Subsequent trip to the well | |
| Reference Log Name: | AIT-GR | |
| Reference Log Run Number: | 1 | |
| Reference Log Date: | 10-Dec-20XX | |
| Subsequent Trip Down Log Correction: | 1.00 FT | |
| Depth Control Remarks | | |
| 1. Subsequent trip to the well. 2. Down pass correlated to reference log within +/- 0.05%. 3. Correlation to reference log performed from XX000 to XX200 ft. 4. Correction applied to match reference log = XX ft, determined at depth XXX00 ft.. 5. Z-chart used as a secondary depth check. | | |

Figure 7. Depth Summary Listing for subsequent trips.

Spudding

Spudding is not a recommended procedure, but it is sometimes necessary to get past an obstruction in the borehole. It generally involves making multiple attempts from varying depths or using varying cable speed to get past an obstruction.

If the distance pulled up is small, the error introduced is also small. In many cases, however, the tool is pulled back up for a considerable distance (i.e., increasing cable over wheel) in an attempt to change its orientation. Then, the correction necessary to maintain proper depth control becomes sizeable.

If multiple attempts are made, the correction necessary to maintain proper depth control also becomes sizeable.

When possible, log data is recorded over the interval where spudding occurs in case consequent damage occurs to the equipment that prevents further data acquisition. If it is not possible to pass an obstruction in the well, data is recorded while pulling out of the hole for remedial action.

Absolute depth

Measurements made with wireline logs are often used as the reference for well depth. However, differences are usually noted between wireline depth and the driller's depth. Which one is correct? The answer is neither. For more information, refer to SPE 110318, "A Technique for Improving the Accuracy of Wireline Depth Measurements."

Wireline depth measurement is subject to environmental corrections that vary with many factors:

- well profile
- mud properties
- toolstring weight
- cable type
- temperature profile
- wellbore pressure
- logging speed.

All these effects may differ from one well to another, so the depth corrections required also differ. Because of the number of factors involved, the corrections can be applied through a numerical model.

Logging down

Any short element of cable that is spooled off the winch drum as a tool is lowered downhole takes up a tension sufficient to support the weight of the tool in the well plus the weight of the cable between the winch and the tool, minus any frictional force that helps support the tool and

cable. This prestretched cable passes the IDW device and its length is thus measured in the stretched condition. When this element of cable is downhole, the tension at the surface can be quite different. However, the tension on this element remains the same because it is still supporting the weight of the tool plus the weight of the cable between itself and the tool minus the frictional force.

If it is assumed that the frictional force is constant and that temperature and pressure do not affect the cable length, the tension on the cable—and thus the cable length—stays constant as the tool is lowered in the hole. Considering that all such elements remain at constant length once they have been measured, it follows that the down log is on depth. This means that the encoder-measured depth incorporates the stretched cable length, and no additional stretch correction is required.

Logging up

When the tool reaches the bottom of the well, the winch direction is reversed. This has the effect of inverting the sign of the frictional component acting on the tool and cable. In addition, if a caliper is opened, the magnitude of the frictional force can change. As a result, the cable everywhere in the borehole is subject to an increase in tension, and thus an increase in stretch.

For the surface equipment to track the true depth correctly, a delta-stretch correction must be added to compensate for the friction change (Fig. 4). Once the correction has been applied, the argument used while running in hole is again applicable, and the IDW correctly measures the displacement of the tool provided there are no further changes in friction.[‡]

Deviated wells

In deviated wells, the preceding depth analysis applies only to the vertical section of the well. Once the tool reaches the dogleg, lateral force from the wellbore supports part of the tool weight. The tool is thus shallower than the measured depth on surface; i.e., the recorded data appear deeper than the actual tool position. This is commonly referred to as tool float.

Correction modeling

Correction modeling software estimates the delta-stretch correction to be applied at the bottom of the well, as well as the expected tool re-zero depth upon return to the surface. This software can be used to correct the depth after logging. Contact your local Schlumberger representative for more information.

[‡]The main assumptions remain that the friction is constant (other than the change due to reversal of direction of cable motion), and that temperature and pressure effects on the cable may be ignored.

Platform Express

Overview

Platform Express* integrated wireline logging technology employs either the AIT* array induction imager tool or High-Resolution Azimuthal Laterolog Sonde (HALS) as the resistivity tool. The Three-Detector Lithology Density (TLD) tool and Micro-Cylindrically Focused Log (MCFL) are housed in the High-Resolution Mechanical Sonde (HRMS) powered caliper. Above the HRMS are a compensated thermal neutron and gamma ray in the Highly Integrated Gamma Ray Neutron Sonde

(HGNS) and a single-axis accelerometer. The real-time speed correction provided by the single-axis accelerometer for sensor measurements enables accurate depth matching of all sensors even if the tool cannot move smoothly while recording data. The resistivity, density, and micro-resistivity measurements are high resolution. Logging speed is twice the speed at which a standard triple-combo is run.

Specifications

| Measurement Specifications | |
|--------------------------------|---|
| Output | HGNS: Gamma ray, neutron porosity, tool acceleration HRMS: Bulk density, photoelectric factor (PEF), borehole caliper, microresistivity HALS: Laterolog resistivity, spontaneous potential (SP), mud resistivity (R_m) AIT: Induction resistivity, SP, R_m |
| Logging speed | 3,600 ft/h [1,097 m/h] |
| Mud weight or type limitations | None |
| Combinability | Bottom-only toolstring with HALS or AIT tool Combinable with most tools |
| Special applications | Good-quality data in sticky or rugose holes Measurement close to the bottom of the well |

| Platform Express Component Specifications | | | | |
|---|---|--|---|--|
| | HGNS | HRMS | HALS | AIT-H and AIT-M |
| Range of measurement | Gamma ray: 0 to 1,000 gAPI Neutron porosity: 0 to 60 V/V | Bulk density: 1.4 to 3.3 g/cm ³ PEF: 1.1 to 10 Caliper: 22 in [55.88 cm] | 0.2 to 40,000 ohm.m | 0.1 to 2,000 ohm.m |
| Vertical resolution | Gamma ray: 12 in [30.48 cm] Porosity: 12 in [30.48 cm] | Bulk density: 18 in [45.72 cm] in 6-in [15.24-cm] borehole | Standard resolution: 18 in [45.72 cm] High resolution: 8 in [20.32 cm] in 6-in [15.24-cm] borehole | 1, 2, and 4 ft [0.30, 0.61, and 1.22 m] |
| Accuracy | Gamma ray: ±5% Porosity: 0 to 20 V/V = ±1 V/V, 30 V/V = ±2 V/V, 45 V/V = ±6 V/V | Bulk density: ±0.01 g/cm ³ (accuracy) ¹ , 0.025 g/cm ³ (repeatability) Caliper: 0.1 in [0.25 cm] (accuracy), 0.05 in [0.127 cm] (repeatability) PEF: 0.15 (accuracy) ² | 1 to 2,000 ohm.m: ±5% | Resistivities: ±0.75 ms/m (conductivity) or 2% (whichever is greater) |
| Depth of investigation | Gamma ray: 24 in [61.0 cm] Porosity: -9 in [-23 cm] (varies with hydrogen index of formation) | Density: 5 in [12.70 cm] | 32 in [81 cm] (varies with formation and mud resistivities) | AQ/AT/AF10 ³ : 10 in [25.40 cm] AQ/AT/AF20: 20 in [50.80 cm] AQ/AT/AF30: 30 in [76.20 cm] AQ/AT/AF60: 60 in [152.40 cm] AQ/AT/AF90: 90 in [228.60 cm] |
| Outside diameter | 3.375 in [8.57 cm] | 4.77 in [12.11 cm] | 3.625 in [9.21 cm] | 3.875 in [9.84 cm] |
| Length | 10.85 ft [3.31 m] | 12.3 ft [3.75 m] | 16 ft [4.88 m] | 16 ft [4.88 m] |
| Weight | 171.7 lbm [78 kg] | 313 lbm [142 kg] | 221 lbm [100 kg] | AIT-H: 255 lbm [116 kg] AIT-M: 282 lbm [128 kg] |

¹ Bulk density accuracy defined only for the range of 1.65 to 3.051 g/cm³

² PEF accuracy defined for the range of 1.5 to 57

³ AQ = 1-ft [0.30-m] vertical resolution, AT = 2-ft [0.61-m] vertical resolution, AF = 4-ft [1.22-m] vertical resolution

Calibration

Master calibration of the HGNS compensated neutron tool must be performed every 3 months. Master calibration of the HRDD density tool must be performed monthly.

For calibration of the gamma ray tool of the HGNS, the area must be free from outside nuclear interference. Gamma ray background and plus calibrations are typically performed at the wellsite with the radioactive sources removed so that no contribution is made to the signal. Calibration of the tool in a vertical position is recommended. The background measurement is made first, and then a plus measurement is made by wrapping the calibration jig around the tool housing and positioning the jig on the knurled section of the gamma ray tool.

Calibration of the HGNS compensated neutron tool uses an aluminum insert sleeve seated in a tank filled with fresh water. The bottom edge of the tank is at least 33 in [84 cm] above the floor, and an 8-ft [2.4-m] perimeter around the tank is clear of walls or stationary items and all equipment, tools, and personnel. The tool is vertically lowered into the tank and sleeve so that only the taper of a centering clamp placed on the tool housing at the centering mark enters the water and the clamp supports the weight of the tool.

Calibration of the HRDD density tool uses an aluminum block and a magnesium block with multiple inserts.

Tool quality control

Standard curves

The Platform Express standard curves are listed in Table 1.

Table 1. Platform Express Standard Curves

| Output Mnemonic | Output Name | Output Mnemonic | Output Name |
|-----------------------------------|--|-----------------|---|
| AHF10, AHF20, AHF30, AHF60, AHF90 | Array induction resistivity with 4-ft [1.2-m] vertical resolution and median depth of investigation of 10, 20, 30, 60, or 90 in [25.4, 50.8, 76.2, 152.4, or 228.6 cm] | HTNP | High-resolution thermal neutron porosity |
| AHO10, AHO20, AHO30, AHO60, AHO90 | Array induction resistivity with 1-ft [0.3-m] vertical resolution and median depth of investigation of 10, 20, 30, 60, or 90 in | MVRA | Monitoring to resistivity of the invaded zone (R_{xo}) voltage ratio |
| AHT10, AHT20, AHT30, AHT60, AHT90 | Array induction resistivity with 2-ft [0.6-m] vertical resolution and median depth of investigation of 10, 20, 30, 60, or 90 in | NPHI | Thermal neutron porosity borehole-size corrected |
| ATEMP | HGNS accelerometer temperature | NPOR | Enhanced-resolution processed thermal porosity |
| CFGR | Gamma ray borehole-correction factor | PEF8 | Formation photoelectric factor at standard 8-in [20.3-cm] resolution |
| CFTC | Corrected far thermal count | PEF1 | Formation photoelectric factor at standard 2-in [5.1-cm] resolution |
| CNTC | Corrected near thermal count | PEFZ | Formation photoelectric factor at standard 18-in [45.7-cm] resolution |
| CTRM | MCFL hardware contrast indicator | RHD8 | Formation density at standard 8-in resolution |
| DNPH | Delta neutron porosity | RHD1 | Formation density at standard 2-in resolution |
| ECGR | Environmentally corrected gamma ray | RHDZ | Formation density at standard 18-in resolution |
| EHGR | High-resolution environmentally corrected gamma ray | RSO8 | High-resolution resistivity standoff |
| EHMR | Confidence on resistivity standoff | RVV | MCFL vertical voltage |
| ERBR[n] | Resistivity reconstruction error | RXGR | Global current-based resistivity |
| ERMC | Confidence on standoff zone resistivity | RXIB | Bucking (A1) current |
| ERX0 | Confidence on invaded zone resistivity | RXIG | Global (A0) current |
| ExSZ[n] | xS reconstruction error | RXIG10 | Global to B0 current ratio |
| GDEV | HGNS deviation | RXO8 | Micro-cylindrically focused R_{xo} measurement at 8-in resolution |
| GR | Gamma ray | RXO1 | Micro-cylindrically focused R_{xo} measurement at 2-in resolution |
| GREZ | High-Resolution Density Detector (HRDD) cost function | RXOZ | Micro-cylindrically focused R_{xo} measurement at standard 18-in resolution |
| GTHV | HGNS gamma ray test high voltage | RXV | R_{xo} (A0) voltage |
| HAZ01 | HGNS high-resolution acceleration | RXVB | Bucking (A1) voltage |
| HCAL | Caliper to measure borehole diameter | TNPH | Thermal neutron porosity environmentally corrected |
| HDRA | HRDD density correction | TREF | HGNS ADC reference |
| HDRX | B0 correction factor | U8 | Formation volumetric photoelectric factor at standard 8-in resolution |
| HGR | High-resolution gamma ray | UI | Formation volumetric photoelectric factor at standard 2-in resolution |
| HLLD | HALS laterolog deep low-resolution measurement | UZ | Formation volumetric photoelectric factor at standard 18-in resolution |
| HLLS | HALS laterolog shallow low-resolution measurement | xQOR | xS crystal resolution |
| HMIN | Micro-inverse resistivity | xDTH | HRDD detector dither frequency |
| HMIND | Micro-normal resistivity | xLEW | xS low-energy window count rate |
| HNPO | High-resolution enhanced thermal neutron porosity | xOFC | HRDD detector offset control value |
| HRLD | HALS laterolog deep high-resolution measurement | xPHV | xS photomultiplier high voltage (command) |
| HRLS | HALS laterolog shallow high-resolution measurement | xSFF | xS form factor |
| HTEM | Cartridge temperature | xWTO | xS uncalibrated total count rate |

Operation

The HGNS section of the Platform Express toolstring must be eccentric with a bow spring. The HRMS is positively eccentric with its own caliper, giving a borehole reaction force centered on the skid face.

The resistivity tool at the bottom of the Platform Express toolstring must be run with standoffs positioned at the top and bottom of the tool. It is important that the standoff size is the same at the top and bottom so that the sonde is not tilted with respect to the borehole.

Planning for selection of the induction or laterolog tool is important. See the "Resistivity Logging" section of this *Log Quality Control Reference Manual* for more details.

Formats

There are several quality control formats for Platform Express logs.

The HGNS format is shown in Fig. 1.

- Flag track
 - This track should show a deep green coherent pattern.
- Track 1
 - CFGR is the coefficient applied to the calibrated gamma ray to take into account the borehole corrections. Normally it is between 0.5 and 1.5.
 - GDEV output from the calibrated accelerometer should be between -10° and 90° , depending on the well.
 - DNPH is the difference between the environmentally corrected porosity and the uncorrected porosity. Usually the difference is within -10 to 10 V/V.

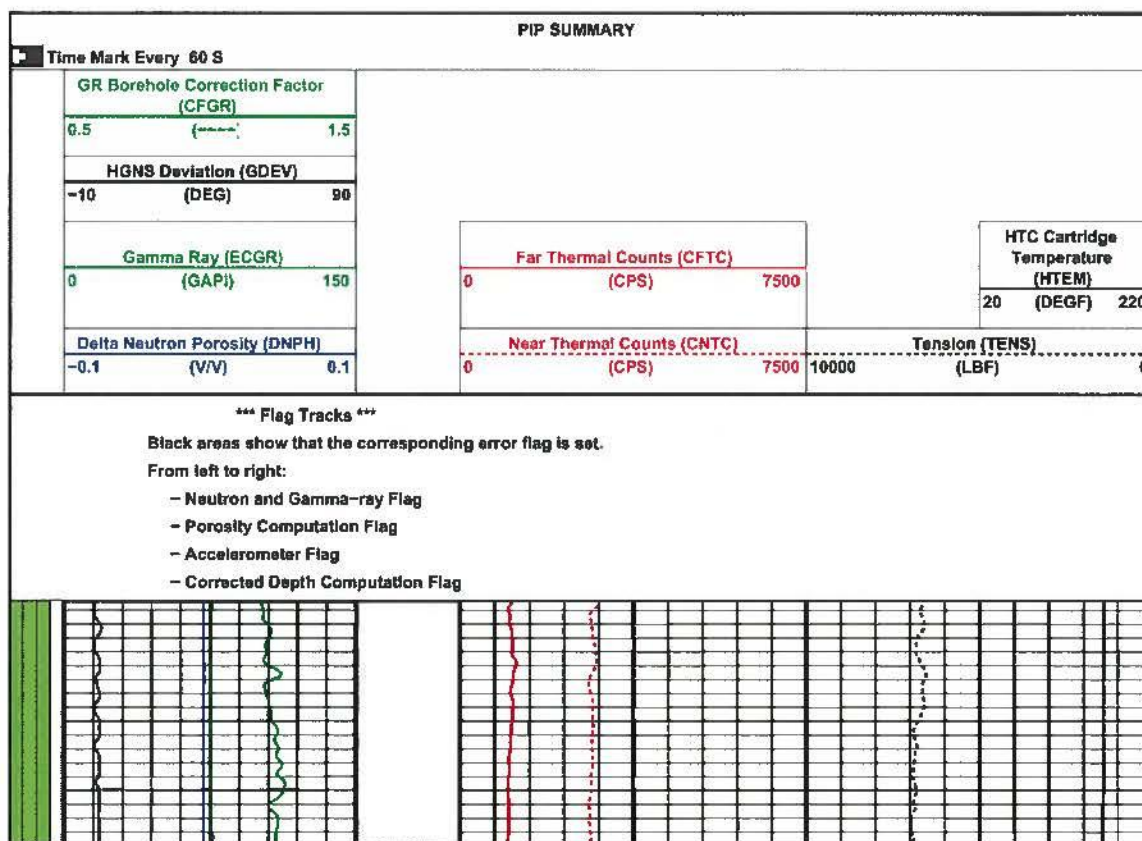

Figure 1. HGNS standard format for hardware.

The HRDD hardware format is in Fig. 2.

- Flag tracks
 - Three flag tracks aid in checking the backscatter (BS), short-spacing (SS), and long-spacing (LS) detector measurements. All bits in the tracks must show a deep green coherent color. Any other color may indicate a hardware failure.
- Tracks 1, 3, and 4
 - The $xWTO$ total count rate varies according to the density. In general, for BS, 300,000 counts/s < $BWTO$ < 1,000,000 counts/s; for SS, 10,000 counts/s < $SWTO$ < 500,000 counts/s; and for LS, 1,000 counts/s < $LWTO$ < 50,000 counts/s (cps on the logs). A large count rate change may indicate a problem with the detector.
 - The value of $xSFF$ varies about zero (typically $\pm 0.125\%$). If the form factor is higher than the permissible value, there may be a problem with the detector.
 - Variation of $xCQR$ detector resolution is according to temperature and the presence of the logging source. Table 2 lists limits for the crystal resolution.

- Valid count rates for $xLEW$ are 0 to 10,000 counts/s for BS, 0 to 5,000 counts/s for SS, and 0 to 1,000 counts/s for LS. Any value outside its range may indicate a problem with the respective detector.
- The $xOFC$ unitless integer controls the average offset value and should range from 5 to 20.
- HRDD backscatter dither frequency ($xDTH$) can range from 1 to 900 Hz.
- The $xPHV$ photomultiplier tube high voltage should be near the value given during master calibration, but it changes with temperature.

Table 2. HRDD Limits for $xCQR$ Crystal Resolution

| Detector | Stabilization Source Alone | | With Logging Source | |
|-----------|----------------------------|------------------------|----------------------|------------------------|
| | 77 degF [25 degC] | 257 degF [125 degC] | 77 degF [25 degC] | 257 degF [125 degC] |
| BS (BCQR) | 13% | 16% | 12% | 15% |
| SS (SCQR) | 10% | 10% | 10% | 10% |
| LS (LCQR) | 9%–10% | 11% | 9% | 11% |

| | | | |
|---|---|---|--|
| BS PM High Voltage (Command) (BPHV) 1600 (V) 1700 | | SS Low Energy Window CR (SLEW) 0 (CPS) 5000 | LS Low Energy Window CR (LLEW) 0 (CPS) 1000 |
| HRDD Backscatter Dither Frequency (BDTH) 0 (HZ) 250 | | SS Uncal. Total CR (SWTO) 0 (CPS) 500000 | LS Uncal. Total CR (LWTO) 0 (CPS) 50000 |
| HRDD Backscatter Offset Control Value (BOFC) 0 (←) 20 | | SS Crystal Resolution (SCQR) 5 (%) 25 | LS Crystal Resolution (LCQR) 5 (%) 25 |
| BS Low Energy Window CR (BLEW) 0 (CPS) 10000 | | SS Form Factor (SSFF) -0.5 (%) 0.5 | LS Form Factor (LSFF) -0.5 (%) 0.5 |
| BS Crystal Resolution (BCQR) 5 (%) 25 | | SS PM High Voltage (Command) (SPHV) 1600 (V) 1700 | LS PM High Voltage (Command) (LPHV) 1600 (V) 1700 |
| BS Form Factor (BSFF) -0.5 (%) 0.5 | | HRDD Short Spacing Dither Frequency (SDTH) 0 (HZ) 250 | HRDD Long Spacing Dither Frequency (LDTH) 0 (HZ) 250 |
| BS Uncal. Total CR (BWTO) 0 (CPS) 1000000 | HILT Caliper (HCAL) 6 (IN) 16 | HRDD Short Spacing Offset Control Value (SOFC) 0 (←) 20 | HRDD Long Spacing Offset Control Value (LOFC) 0 (←) 20 |

*** Flag Tracks ***

Black areas show that the corresponding error flag is set.

For each xS detector subtrack, and from left to right :

- xS Offset Error or Low Energy Window Error
- xS Tau Loop Error (Pulse Shape Compensation Error)
- xS Stabilization Loop or Crystal Resolution Error

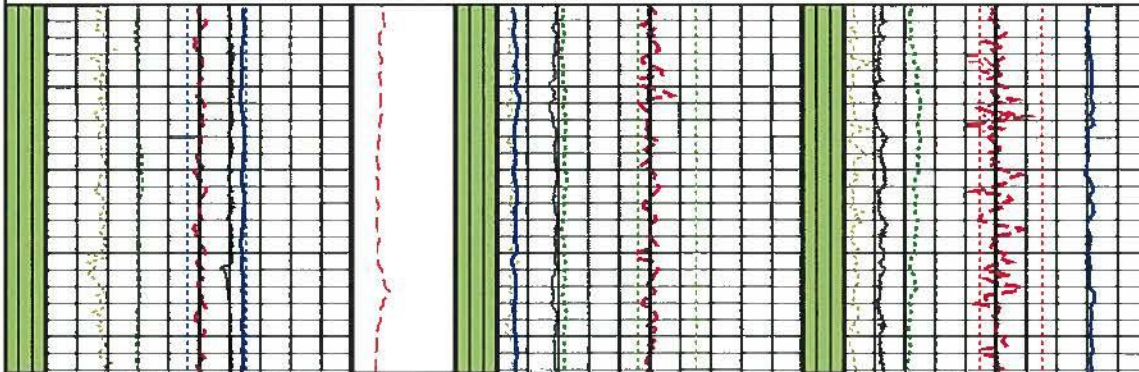

Figure 2. HRDD standard format for hardware.

The HRDD processing format is in Fig. 3.

- Tracks 1, 2, and 3
 - $E_{xSZ}[n]$ for each detector shows how close the reconstructed count rates are to the calibrated measured count rates. Ideally, they should vary about zero. A large bias observed on these errors for one or more energy windows is generally due to a problem in the calibration, excessive pad wear, or incorrect inversion algorithm selection.
 - GREZ indicates the confidence level in the estimations done in the model. The valid range is $0 < GREZ < 25$.

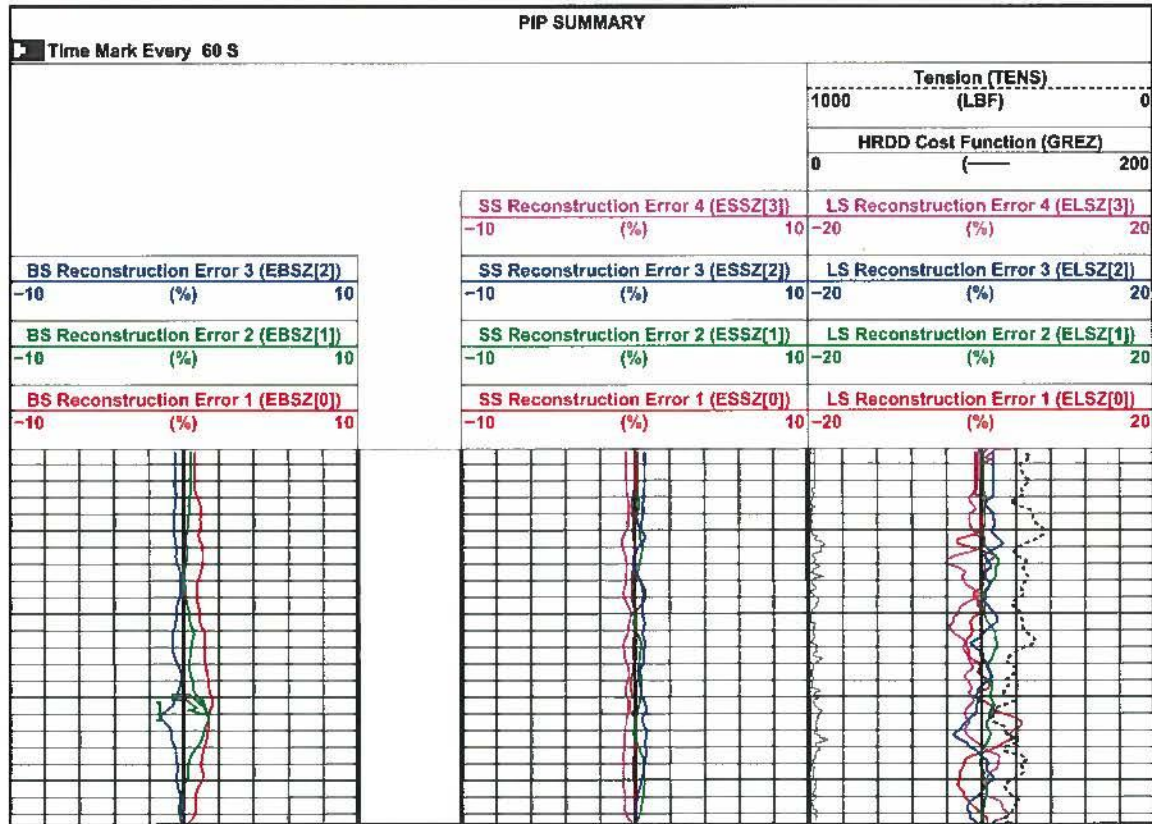

Figure 3. HRDD standard format for processing.

The MCFL hardware format is in Fig. 4.

- Flag track
 - The flag track should show a deep green coherent color. If a flag appears, it indicates a hardware malfunction.
- Track 1
 - RXIB and RXIG from A0 and A1 (the guard electrodes on the tool) should range from 2 to 2,000 mA. The ratio between both curves should be constant, with the value depending on the hole size.
 - RXV between the A0 electrode and the sonde body is typically about 50 to 200 mV for $R_{xo} > 10$ ohm.m. It is smaller when $R_{xo} < 10$ ohm.m, but it should not go below 5 mV.
 - RVV between A0 and the reference electrode N should read about one-half the value of RXV (R_{xo} voltage).

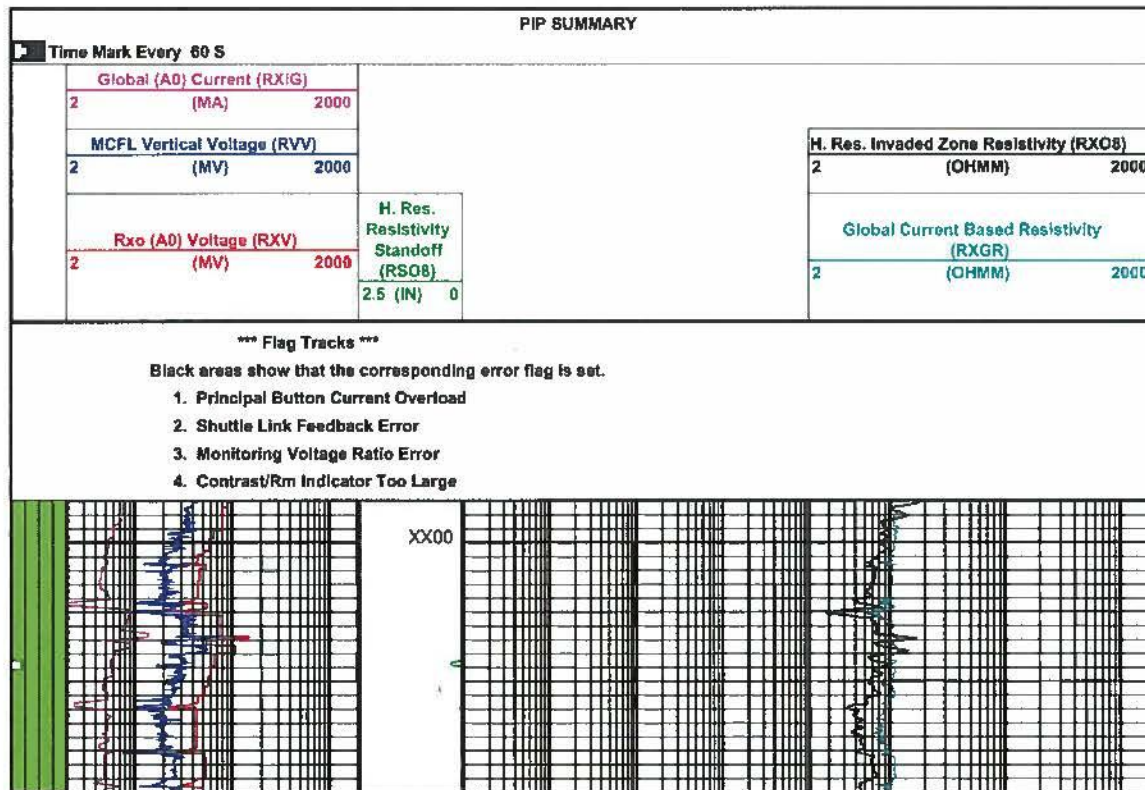

Figure 4. MCFL standard format for hardware.

The MCFL processing format is in Fig. 5.

- Track 1
 - ERBR[n] for the response of each button is used to determine how close the reconstructed measurements are to the actual ones. High error values can indicate abnormal noise level, non-homogeneous R_{xo} value, or standoff resulting from sonde tilt.
- Track 2
 - ERXO, ERMC, and EHMR confidence indicators for R_{xo} , R_{mc} , and mudcake thickness, respectively, indicate the amount of error associated with the results of the MCFL inversion. These curves should remain close to zero.
- Track 3
 - HDRX applied to the main button to match the inverted output RXOZ should range between 0.5 and 1.5.

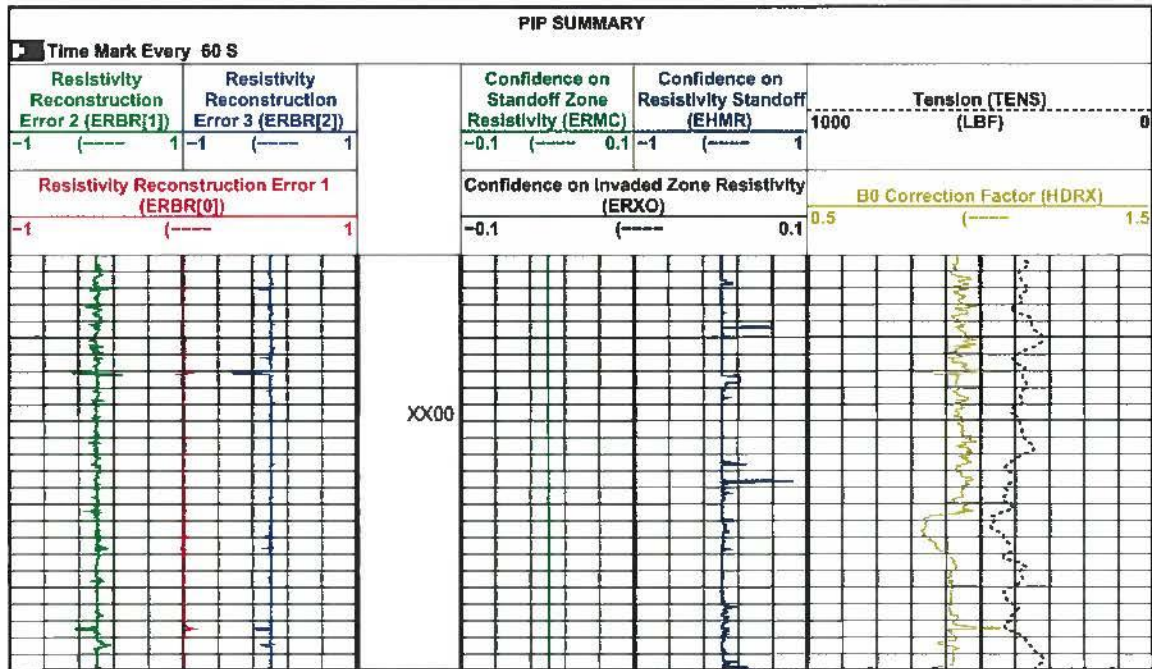

Figure 5. MCFL standard format for processing.

Response in known conditions

HGNS neutron response

The values in Table 3 assume that the matrix parameter is set to limestone (MATR = LIME), hole is in gauge, and borehole corrections are applied.

HRDD density response

Typical values for the HRDD response are in Table 4.

MCFL microresistivity response

- In impermeable zones, the R_{20} curve should equal the induction or resistivity measurements.
- In permeable zones, the R_{20} curve should show a coherent profile as an indication of invasion.

AIT and HALS resistivity response

- In impermeable zones, the resistivity curves should overlay.
- In permeable zones, the relative position of the curves should show a coherent profile depending on the values of the resistivity of the mud filtrate (R_{mf}) and the resistivity of the water (R_w), the respective saturation, and the depth of invasion. In salt muds, generally the invasion profile is such that deeper-reading curves have a higher value than shallower-reading curves, with deep investigation curves approaching the true formation resistivity (R_t) and shallow investigation curves approaching R_{20} .

Table 3. Typical HGNS Response in Known Conditions

| Formation | NPHI, [†] V/V | TNPH or NPOR, [‡] V/V |
|--------------------------------------|-------------------------------------|--|
| Sandstone, 0% porosity | -1.7 | -2.0 |
| Limestone, 0% porosity | 0 | 0 |
| Dolomite, 0% porosity | 2.4 | 0.7 |
| Sandstone, 20% porosity [§] | 15.8 if formation salinity = 0 ug/g | 15.1 if formation salinity = 250 ug/g |
| Limestone, 20% porosity | 20.0 | 20.0 |
| Dolomite, 20% porosity [§] | 27.2 if formation salinity = 0 ug/g | 22.6 if formation salinity = 0 ug/g 24.1 if formation salinity = 250 ug/g |
| Anhydrite | -0.2 | -2.0 |
| Salt | -0.0 | -3.0 |
| Coal | 38 to 70 | 28 to 70 |
| Shale | 30 to 60 | 30 to 60 |

[†] After borehole correction with MATR = LIME. Refer to Chart CP-1c in Schlumberger *Log Interpretation Charts*.

[‡] After borehole correction with MATR = LIME. Refer to Charts CP-1e and -1f in Schlumberger *Log Interpretation Charts*.

[§] The reason that sandstone or dolomite with a porosity of 20% reads differently after environmental correction with MATR = LIME for different formation salinities is that the formation salinity correction is matrix dependant, and a formation salinity correction made assuming MATR = LIME is incorrect if the matrix is different. Refer to Chart Por-13b in Schlumberger *Log Interpretation Charts*.

Table 4. Typical HRDD Response in Known Conditions

| Formation | RHOB, g/cm ³ | PEF [†] |
|------------------------|-------------------------|------------------|
| Sandstone, 0% porosity | 2.65 to 2.68 | 1.81 |
| Limestone, 0% porosity | 2.71 | 5.08 |
| Dolomite, 0% porosity | 2.87 | 3.14 |
| Anhydrite | 2.98 | 5.05 |
| Salt | 2.04 | 4.65 |
| Coal | 1.2 to 1.7 | 0.2 |
| Shale | 2.1 to 2.8 | 1.8 to 6.3 |

[†] PEF readings are restricted to not read below 0.8.

PS Platform

Overview

The PS Platform* production services platform uses a modular design comprising the following main tools:

- Platform Basic Measurement Sonde (PBMS) for measuring pressure, temperature, gamma ray, and casing collar location
- Gradiomanometer* (PGMC) sonde for measuring the density of the well fluid and well deviation
- PS Platform Inline Spinner (PILS) for measuring high-velocity flow in small-diameter tubulars
- Flow-Caliper Imaging Sonde (PFCS) for measuring fluid velocity and water holdup and also has a dual-axis caliper.

Additional production logging tools combinable with the PS Platform system are

- GHOST* gas optical holdup sensor tool for measuring gas holdup and also has a caliper
- Digital Entry and Fluid Imaging Tool (DEFT) for measuring water and also has a caliper
- Flow Scanner* horizontal and deviated well production logging system for measuring three-phase flow rate in horizontal wells
- RST* reservoir saturation tool for measuring water velocity and three-phase holdup.

Also combinable with the PS Platform system are

- SCMT* slim cement mapping tool for a through-tubing cement quality log
- PS Platform Multifinger Imaging Tool (PMIT) for multifinger caliper surveys of pitting and erosion
- EM Pipe Scanner* electromagnetic casing inspection tool for electromagnetic inspection of corrosion and erosion
- RST reservoir saturation tool for capture sigma saturation logging, carbon/oxygen saturation logging, capture lithology identification, and silicon-activation gravel-pack quality logging.

In horizontal wells the PBMS can be replaced by the MaxTRAC* down-hole well tractor system or the TuffTRAC* cased hole services tractor.

RST and RSTPro

Overview

The dual-detector spectrometry system of the through-tubing RST* and RSTPro* reservoir saturation tools enables the recording of carbon and oxygen and Dual-Burst* thermal decay time measurements during the same trip in the well.

The carbon/oxygen (C/O) ratio is used to determine the formation oil saturation independent of the formation water salinity. This calculation is particularly helpful if the water salinity is low or unknown. If the salinity of the formation water is high, the Dual-Burst measurement is used. A combination of both measurements can be used to detect and quantify the presence of injection water of a different salinity from that of the connate water.

Specifications

| Measurement Specifications | |
|-------------------------------------|---|
| | RST and RSTPro Tools |
| Output | Inelastic and capture yields of various elements, carbon/oxygen ratio, formation capture cross section (sigma), porosity, borehole holdup, water velocity, phase velocity, SpectroLith* processing |
| Logging speed [†] | Inelastic mode: 100 ft/h [30 m/h] (formation dependent) Capture mode: 600 ft/h [183 m/h] (formation and salinity dependent) RST sigma mode: 1,800 ft/h [549 m/h] RSTPro sigma mode: 2,800 ft/h [850 m/h] |
| Range of measurement | Porosity: 0 to 60 V/V |
| Vertical resolution | 15 in [38.10 cm] |
| Accuracy | Based on hydrogen index of formation |
| Depth of investigation [‡] | Sigma mode: 10 to 16 in [20.5 to 40.6 cm] Inelastic capture (IC) mode: 4 to 6 in [10.2 to 15.2 cm] |
| Mud type or weight limitations | None |
| Combinability | RST tool: Combinable with the PL Flagship* system and CPLT* combinable production logging tool RSTPro tool: Combinable with tools that use the PS Platform* telemetry system and Platform Basic Measurement Sonde (PBMS) |

[†] See Tool Planner application for advice on logging speed.

[‡] Depth of investigation is formation and environment dependent.

Calibration

The master calibration of the RST and RSTPro tools is conducted annually to eliminate tool-to-tool variation. The tool is positioned within a polypropylene sleeve in a horizontally positioned calibration tank filled with chlorides-free water.

The sigma, WFL* water flow log, and PVL* phase velocity log modes of the RST and RSTPro detectors do not require calibration. The gamma ray detector does not require calibration either.

| Mechanical Specifications | | |
|---------------------------|--|--|
| | RST-A and RST-C | RST-B and RST-D |
| Temperature rating | 302 degF [150 degC] With flask: 400 degF [204 degC] | 302 degF [150 degC] |
| Pressure rating | 15,000 psi [103 MPa] With flask: 20,000 psi [138 MPa] | 15,000 psi [103 MPa] |
| Borehole size—min. | 1 ³ / ₁₆ in [4.60 cm] With flask: 2 ¹ / ₄ in [5.72 cm] | 2 ¹ / ₄ in [7.30 cm] |
| Borehole size—max. | 9 ⁵ / ₁₆ in [24.45 cm] With flask: 9 ⁵ / ₁₆ in [24.45 cm] | 9 ⁵ / ₁₆ in [24.45 cm] |
| Outside diameter | 1.71 in [4.34 cm] With flask: 2.875 in [7.30 cm] | 2.51 in [6.37 cm] |
| Length | 23.0 ft [7.01 m] With flask: 33.6 ft [10.25 m] | 22.2 ft [6.76 m] |
| Weight | 101 lbm [46 kg] With flask: 243 lbm [110 kg] | 208 lbm [94 kg] |
| Tension | 10,000 lbf [44,480 N] With flask: 25,000 lbf [111,250 N] | 10,000 lbf [44,480 N] |
| Compression | 1,000 lbf [4,450 N] With flask: 1,800 lbf [8,010 N] | 1,000 lbf [4,450 N] |

Tool quality control

Standard curves

The RST and RSTPro standard curves are listed in Table 1.

Table 1. RST and RSTPro Standard Curves

| Output Mnemonic | Output Name |
|-----------------|---|
| BADL_DIAG | Bad level diagnostic |
| CCRA | RST near/far instantaneous count rate |
| CDR | Carbon/oxygen ratio |
| CRRA | Near/far count rate ratio |
| CRRR | Count rate regulation ratio |
| DSIG | RST sigma difference |
| FBAC | Multichannel Scaler (MCS) far background |
| FBEF | Far beam effective current |
| FCOR | Far carbon/oxygen ratio |
| FEGF | Far capture gain correction factor |
| FEOF | Far capture offset correction factor |
| FERD | Far capture resolution degradation factor (RDF) |
| FIGF | Far inelastic gain correction |
| FIOF | Far inelastic offset correction factor |
| FIRD | Far inelastic RDF |
| IC | Inelastic capture |
| IRAT_FIL | RST near/far inelastic ratio |
| NBEF | Near beam effective current |
| NCOR | Near carbon/oxygen ratio |
| NEGF | Near capture gain correction factor |
| NEOF | Near capture offset correction factor |
| NERD | Near capture RDF |
| NIGF | Near inelastic gain correction |
| NIOF | Near inelastic offset correction factor |
| NIRD | Near inelastic RDF |
| RSCF_RST | RST selected far count rate |
| RSCN_RST | RST selected near count rate |
| SBNA | Sigma borehole near apparent |
| SFFA_FIL | Sigma formation far apparent |
| SFNA_FIL | Sigma formation near apparent |
| SIGM | Formation sigma |
| SIGM_SIG | Formation sigma uncertainty |
| TRAT_FIL | RST near/far capture ratio |

Operation

The RST and RSTPro tools should be run eccentered. The main inelastic capture characterization database does not support a centered tool, thus it is important to ensure that the tool is run eccentered. However, for a WFL water flow log, a centered tool is recommended to better evaluate the entire wellbore region.

Formats

The format in Fig. 1 is used mainly as a hardware quality control.

- Depth track
 - Deflection of the BADL_DIAG curve by 1 unit indicates that frame data are being repeated (resulting from fast logging speed or stalled data). A deflection by 2 units indicates bad spectral data (too-low count rate).
- Track 1
 - CRRA, CRRR, NBEF, and FBEF are shown; FBEF should track openhole porosity when properly scaled.
- Track 6
 - The IC mode gain correction factors measure the distortion of the energy inelastic and elastic spectrum in the near and far detectors relative to laboratory standards. They should read between 0.98 and 1.02.
- Track 7
 - The IC mode offset correction factors are described in terms of gain, offset, and resolution degradation of the inelastic and elastic spectrum in the near and far detectors. They should read between -2 and 2.
- Track 8
 - Distortion on these curves affects inelastic and capture spectra from the near and far detectors. They should be between 0 and 15. Anything above 15 indicates a tool problem or a tool that is too hot (above 302 degF [150 degC]), which affects yield processing.

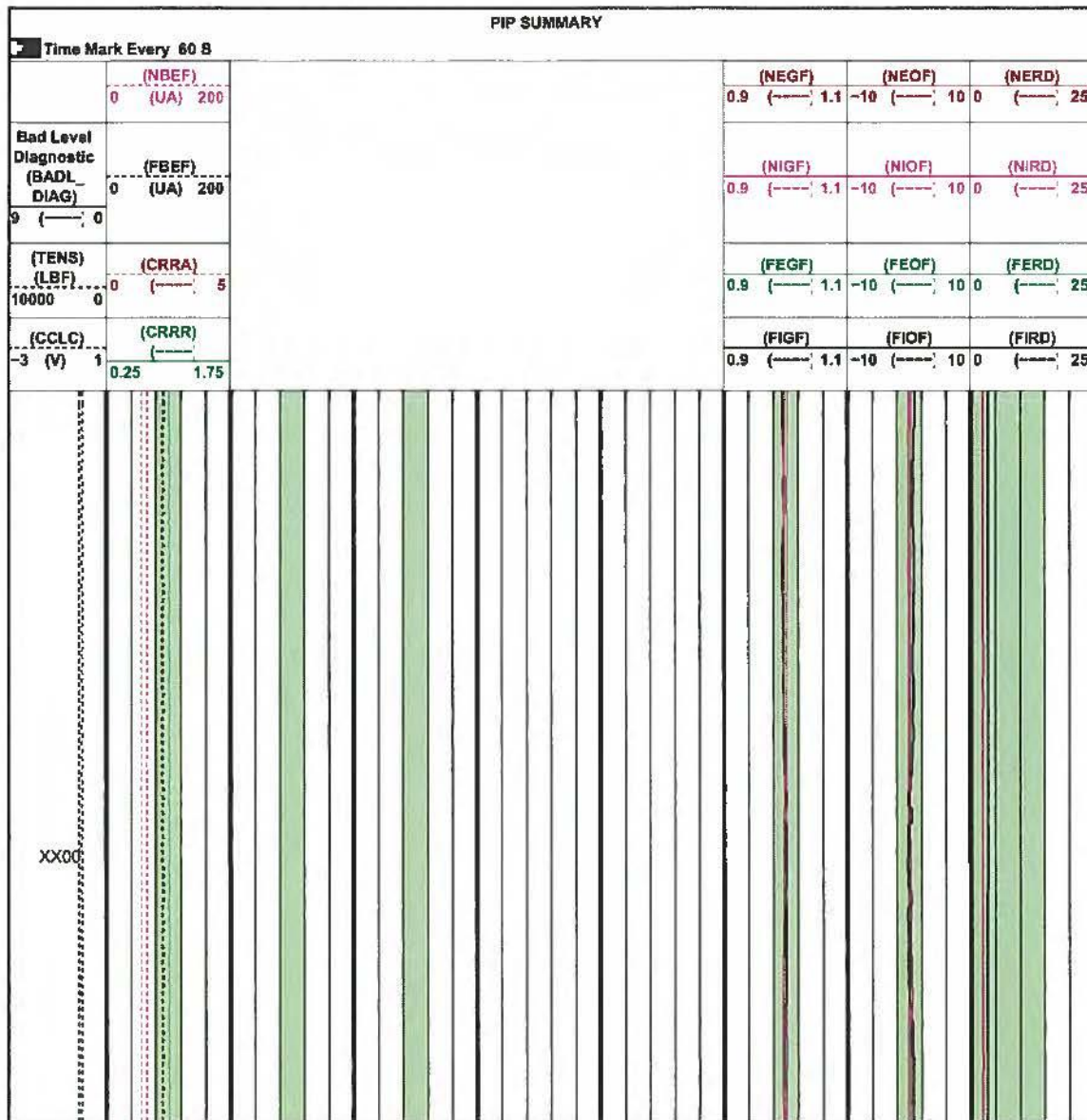

Figure 1. RST and RSTPro hardware format.

The format in Fig. 2 is used mainly for sigma quality control.

- Depth track
 - Deflection of the BADL_DIAG curve by 1 unit indicates that frame data are being repeated (resulting from fast logging speed or stalled data). A deflection by 2 units indicates bad spectral data (too-low count rate).
- Tracks 2 and 3
 - The IRAT_FIL inelastic ratio increases in gas and decreases with porosity.
 - DSIG in a characterized completion should equal approximately zero. Departures from zero indicate either the environmental parameters are set incorrectly or environment is different from the characterization database (e.g., casing is not fully centered in the wellbore or the tool is not eccentered). Shales typically read 1 to 4 units from the baseline of zero because they are not characterized in the database.

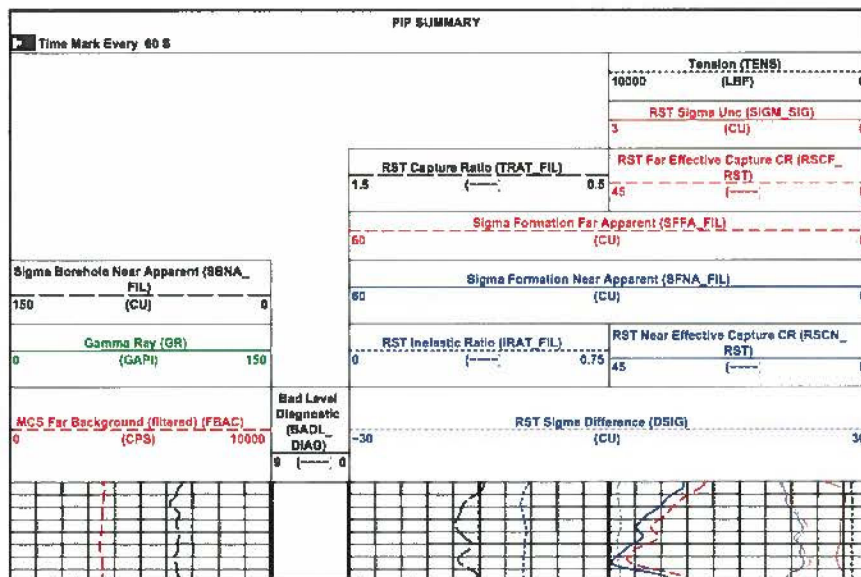

Figure 2. RST and RSTPro sigma standard format.

Response in known conditions

In front of a clean water zone, COR is smaller than the value logged across an oil zone. Oil in the borehole affects both the near and far COR, causing them to read higher than in a water-filled borehole. In front of shale, high COR is associated with organic content.

The computed yields indicate contributions from the materials being measured (Table 2).

Table 2. Contributing Materials to RST and RSTPro Yields

| Element | Contributing Material |
|---------|---|
| C and O | Matrix, borehole fluid, formation fluid |
| Si | Sandstone matrix, shale, cement behind casing |
| Ca | Carbonates, cement |
| Fe | Casing, tool housing |

Bad cement quality affects readings (Table 3). A water-filled gap in the cement behind the casing appears as water to the IC measurement. Conversely, an oil-filled gap behind the casing appears as oil to the IC measurement.

Table 3. RST and RSTPro Capture and Sigma Modes

| Medium | Sigma, cu |
|---------------|-----------|
| Oil | 18 to 22 |
| Gas | 0 to 12 |
| Water, fresh | 20 to 22 |
| Water, saline | 22 to 120 |
| Matrix | 8 to 12 |
| Shale | 35 to 55 |

Cement Bond Tool

Overview

The cement bond log (CBL) made with the Cement Bond Tool (CBT) provides continuous measurement of the attenuation of sound pulses, independent of casing fluid and transducer sensitivity. The tool is self-calibrating and less sensitive to eccentricity and sonde tilt than the traditional single-spacing CBL tools. The CBT additionally gives the attenuation of sound pulses from a receiver spaced 0.8 ft [0.24 m] from the transmitter, which is used to aid interpretation in fast formations.

A CBL curve computed from the three attenuations available enables comparison with CBLs based on the typical 3-ft [0.91-m] spacing. This computed CBL continuously discriminates between the three attenuations to choose the one best suited to the well conditions. An interval transit-time curve for the casing is also recorded for interpretation and quality control.

A Variable Density* log (VDL) is recorded simultaneously from a receiver spaced 5 ft [1.52 m] from the transmitter. This display provides information on the cement/formation bond and other factors that are important to the interpretation of cement quality.

Specifications

| Measurement Specifications | |
|--------------------------------|---|
| Output | Attenuation measurement, CBL, VDL image, transit times |
| Logging speed | 1,800 ft/h [549 m/h] ¹ |
| Range of measurement | Formation and casing dependent |
| Vertical resolution | CBL: 3 ft [0.91 m] VDL: 5 ft [1.52 m] Cement map: 2 ft [0.61 m] |
| Accuracy | Formation and casing dependent |
| Depth of investigation | CBL: casing and cement interface VDL: depends on bonding and formation |
| Mud type or weight limitations | None |

¹ Speed can be reduced depending on data quality.

| Measurement Specifications | |
|----------------------------|----------------------|
| Temperature rating | 350 degF [177 degC] |
| Pressure rating | 20,000 psi [138 MPa] |
| Borehole size—min. | 3.375 in [8.57 cm] |
| Borehole size—max. | 13.375 in [33.97 cm] |
| Outside diameter | 2.75 in [6.985 cm] |
| Weight | 309 lbm [140 kg] |

Calibration

Sonde normalization of sonic cement bond tools is performed with every Q-check. Q-check frequency is also dependent on the number of jobs run, exposure to high temperature, and other factors.

The sonic checkout setup used for calibration is supported with two stands, one on each end. A stand in the center of the tube would distort the waveform and cause errors. One end of the tube is elevated to assist in removing all air in the system, and the tool is positioned in the tube with centralizer rings.

Tool quality control

Standard curves

CBT standard curves are listed in Table 1.

Table 1. CBT Standard Curves

| Output Mnemonic | Output Name |
|-----------------|---|
| CCL | Casing collar locator amplitude |
| DATN | Discriminated BHC attenuation |
| DBI | Discriminated bond index |
| DCBL | Discriminated synthetic CBL |
| DT | Interval transit time of casing (delta- <i>t</i>) |
| DTMD | Delta- <i>t</i> mud (mud slowness) |
| GR | Gamma ray |
| NATN | Near 2.4-ft attenuation |
| NBI | Near bond index |
| NCBL | Near synthetic CBL |
| R32R | Ratio of receiver 3 sensitivity to receiver 2 sensitivity, dB |
| SATN | Short 0.8-ft attenuation [†] |
| SB1 | Short bond index [†] |
| SCBL | Short synthetic CBL [†] |
| TT1 | Transit time for mode 1 (upper transmitter, receiver 3 [UT-R3]) |
| TT2 | Transit time for mode 2 (UT-R2) |
| TT3 | Transit time for mode 3 (lower transmitter, receiver 2 [LT-R2]) |
| TT4 | Transit time for mode 4 (LT-R3) |
| TT6 | Transit time for mode 6 (UT-R1) |
| ULTR | Ratio of upper transmitter output strength to the lower transmitter output strength |
| VDL | Variable Density log |

[†] In fast formations only

Operation

The tool should be run centralized.

A log should be made in a free-pipe zone (if available). Where a micro-annulus is suspected, a repeat section should be made with pressure applied to the casing.

Formats

The format in Fig. 1 is used both as an acquisition and quality control format.

- Track 1
 - DT and DTMD are derived from the transit-time measurements from all transmitter-receiver pairs. They respond to eccentricization of any of the six measurements modes and are a sensitive indicator of wellbore conditions. In a low-quality cement bond or free pipe, both readings are correct. In well-bonded sections, the transit time may cycle skip, affecting the DT and DTMD values.
 - CCL deflects in front of casing collars.
 - GR is used for correlation purposes.

- Track 2
 - DCBL is related to casing size, casing weight, and mud. As a quality control DCBL should be checked against the expected responses in known conditions (see the following section). Also, DCBL should match the VDL image readings.
- Track 3
 - VDL is a map of the waveform amplitude versus depth and it should have good contrast. It provides information on the cement/formation bond, which is important for cement quality interpretation. The VDL image should be cross checked that it matches the DCBL readings. For example, in a free-pipe section, the DCBL amplitude reads high and VDL shows strong casing arrivals with no formation arrivals. In a zone of good bond for the casing to the formation, the CBL amplitude reads low and the VDL has weak casing arrivals and clear formation arrivals.

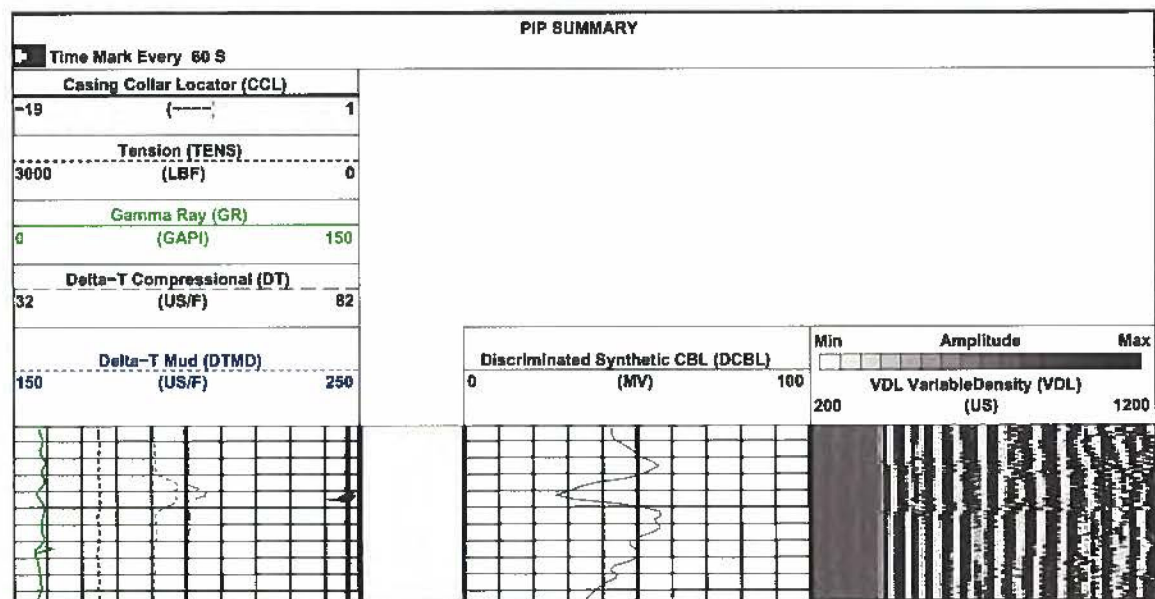

Figure 1. CBT standard format for CBL and VDL.

The format in Fig. 2 is also used both as an acquisition and quality control format.

- Track 1
 - The transit time pairs should overlay (TT1C overlays TT3C, and TT2C overlays TT4C) because these pairs are derived from equivalent transmitter-receiver spacings. In very good cement sections, the transit-time curve may be affected by cycle skipping. DT and DTMD may be also affected.
- Track 2
 - The ULTR and R32R ratios are quality indicators of the transmitter or receiver strengths. They should be $0 \text{ dB} \pm 3 \text{ dB}$, unless one of the transmitters or receivers is weak. Both curves should be checked for consistency and stability.

- Track 3
 - DATN should equal NATN in free-pipe sections. In the presence of cement behind casing and in normal conditions, NATN reads higher than DATN.
- Track 4
 - VDL is a map of the waveform amplitude versus depth that should have good contrast. It provides information on the cement/formation bond, which is important for cement quality interpretation. The VDL image should be cross checked that it matches the DCBL readings.

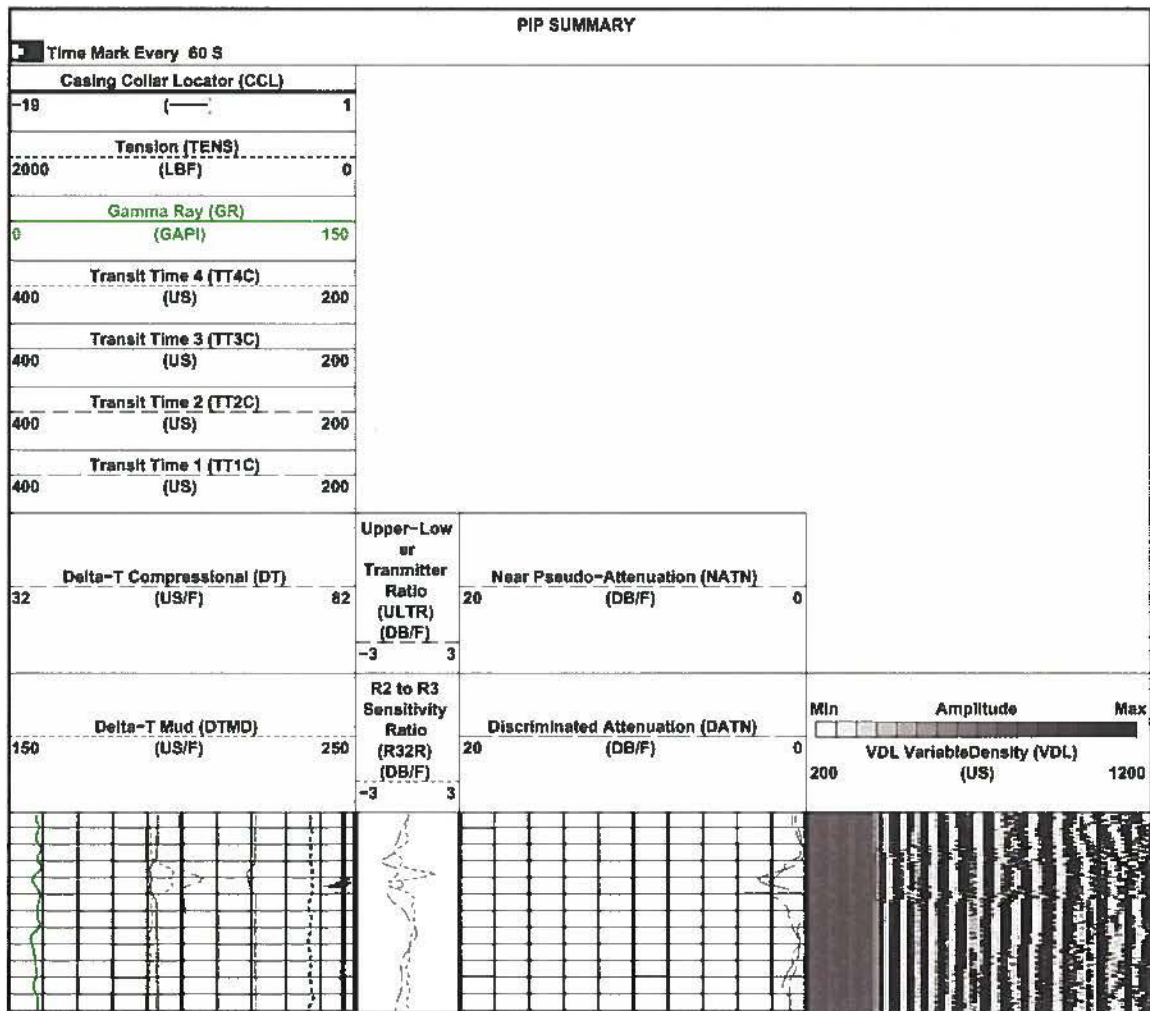

Figure 2. Additional CBT standard format for CBL and VDL.

Response in known conditions

- DT in casing should read the value for steel (57 us/ft \pm 2 us/ft [187 us/m \pm 6.6 us/m]).
- DTMD should be compared with known velocities (water-base mud: 180–200 us/ft [590–656 us/m], oil-base mud: 210–280 us/ft [689–919 us/m]).
- Typical responses for different casing sizes and weights are listed in Table 2.

Table 2. Typical CBT Response in Known Conditions

| Casing Size, in | Casing Weight, lbm/ft | DCBL in Free Pipe, mV | TT1, us | TT2, us | TT5, us |
|-----------------|-----------------------|-----------------------|---------|---------|-----------------|
| 4.5 | 11.6 | 84 \pm 8 | 252 | 195 | 104 |
| 5 | 13 | 77 \pm 7 | 259 | 203 | 112 |
| 5.5 | 17 | 71 \pm 7 | 267 | 210 | 120 |
| 7 | 24 | 61 \pm 6 | 290 | 233 | 140 |
| 8.625 | 38 | 55 \pm 6 | 314 | 257 | 166 |
| 9.625 | 40 [†] | 52 \pm 5 | 329 | 272 | NM [‡] |

[†] Although the CBT operates in up to 13 $\frac{3}{8}$ -in casing, the VDL presentation mainly shows casing arrivals where casings of 9 $\frac{5}{8}$ in and larger are logged.

[‡] NM = not meaningful

Cement Bond Logging

Overview

Cement bond tools measure the bond between the casing and the cement placed in the annulus between the casing and the wellbore. The measurement is made by using acoustic sonic and ultrasonic tools. In the case of sonic tools, the measurement is usually displayed on a cement bond log (CBL) in millivolt units, decibel attenuation, or both. Reduction of the reading in millivolts or increase of the decibel attenuation is an indication of better-quality bonding of the cement behind the casing to the casing wall. Factors that affect the quality of the cement bonding are

- cement job design and execution as well as effective mud removal
- compressive strength of the cement in place
- temperature and pressure changes applied to the casing after cementing
- epoxy resin applied to the outer wall of the casing.

The recorded CBL provides a continuous measurement of the amplitude of sound pulses produced by a transmitter-receiver pair spaced 3-ft [0.91-m] apart. This amplitude is at a maximum in uncemented free pipe and minimized in well-cemented casing. A transit-time (TT) curve of the waveform first arrival is also recorded for interpretation and quality control.

A Variable Density* log (VDL) is recorded simultaneously from a receiver spaced 5 ft [1.52 m] from the transmitter. The VDL display provides information on the cement quality and cement/formation bond.

Specifications

Measurement Specifications

| | Digital Sonic Logging Tool (DSL [†]) and Hostile Environment Sonic Logging Tool (HSLT) with Borehole-Compensated (BHC) | Slim Array Sonic Tool (SSLT) and SlimXtreme* Sonic Logging Tool (QSLT) |
|--------------------------------|---|--|
| Output | SLS-C, SLS-D, SLS-W, and SLS-E [†] 3-ft [0.91-m] CBL Variable Density waveforms | 3-ft [0.91-m] CBL and attenuation 1-ft [0.30-m] attenuation 5-ft [1.52-m] Variable Density waveforms |
| Logging speed | 3,600 ft/h [1,097 m/h] | 3,600 ft/h [1,097 m/h] |
| Range of measurement | 40 to 200 us/ft [131 to 656 us/m] | 40 to 400 us/ft [131 to 1,312 us/m] |
| Vertical resolution | Amplitude (mV): 3 ft [0.91 m] VDL: 5 ft [1.52 m] | Near attenuation: 1 ft [0.30 m] Amplitude (mV): 3 ft [0.91 m] VDL: 5 ft [1.52 m] |
| Depth of investigation | Synthetic CBL from discriminated attenuation (DCBL): Casing and cement interface VDL: Depends on cement bonding and formation properties | DCBL: Casing and cement interface VDL: Depends on cement bonding and formation properties |
| Mud type or weight limitations | None | None |
| Special applications | | Conveyed on wireline, drillpipe, or coiled tubing Logging through drillpipe and tubing, in small casings, fast formations |

[†] The DSLT uses the Sonic Logging Sonde (SLS) to measure cement bond amplitude and VDL evaluation.

Mechanical Specifications

| | DSL T | HSL T | SSL T | QSL T |
|--------------------|---|--|---|---|
| Temperature rating | 302 degF [150 degC] | 500 degF [260 degC] | 302 degF [150 degC] | 500 degF [260 degC] |
| Pressure rating | 20,000 psi [138 MPa] | 25,000 psi [172 MPa] | 14,000 psi [97 MPa] | 30,000 psi [207 MPa] |
| Casing ID—min. | 5 in [12.70 cm] | 5 in [12.70 cm] | 3½ in [8.89 cm] | 4 in [10.16 cm] |
| Casing ID—max. | 18 in [45.72 cm] | 18 in [45.72 cm] | 8 in [20.32 cm] | 8 in [20.32 cm] |
| Outside diameter | 3¾ in [9.21 cm] | 3¾ in [9.53 cm] | 2½ in [6.35 cm] | 3 in [7.62 cm] |
| Length | SLS-C and SLS-D: 18.7 ft [5.71 m] SLS-E and SLS-W: 20.6 ft [6.23 m] | With HSLS-W sonde: 25.5 ft [7.77 m] | 23.1 ft [7.04 m] With inline centralizers: 29.6 ft [9.02 m] | 23 ft [7.01 m] With inline centralizers: 29.9 ft [9.11 m] |
| Weight | SLS-C and SLS-D: 273 lbm [124 kg] SLS-E and SLS-W: 313 lbm [142 kg] | With HSLS-W sonde: 440 lbm [199 kg] | 232 lbm [105 kg] With inline centralizers: 300 lbm [136 kg] | 295 lbm [134 kg] With inline centralizers: 407 lbm [185 kg] |
| Tension | 29,700 lbf [132,110 N] | 29,700 lbf [132,110 N] | 13,000 lbf [57,830 N] | 13,000 lbf [57,830 N] |
| Compression | SLS-C and SLS-D: 1,700 lbf [7,560 N] SLS-E and SLS-W: 2,870 lbf [12,770 N] | With HSLS-W sonde: 2,870 lbf [12,770 N] | 4,400 lbf [19,570 N] | 4,400 lbf [19,570 N] |

Calibration

Sonde normalization of sonic cement bond tools is performed with every Q-check. Scheduled frequency of Q-checks varies for each tool. Q-check frequency is also dependent on the number of jobs run, exposure to high temperature, and other factors.

The sonic checkout setup used for calibration is supported with two stands, one on each end. A stand in the center of the tube would distort the waveform and cause errors. One end of the tube is elevated to assist in removing all air in the system, and the tool is positioned in the tube with centralizer rings.

Tool quality control

Standard curves

CBL standard curves are listed in Table 1.

Table 1. CBL Standard Curves

| Output Mnemonic | Output Name |
|-----------------|-----------------------------------|
| BI | Bond index |
| CBL | Cement bond log (fixed gate) |
| CBLF | Fluid-compensated cement bond log |
| CBSL | Cement bond log (sliding gate) |
| CCL | Casing collar log |
| GR | Gamma ray |
| TT | Transit time (fixed gate) |
| TTSL | Transit time (sliding gate) |
| VDL | Variable Density log |

Operation

The tool must be run centralized.

A log should be made in a free-pipe zone (if available). Where a micro-annulus is suspected, a repeat section should be made with pressure applied to the casing.

Formats

The format in Fig. 1 is used for both acquisition and quality control.

- Track 1
 - TT and TTSL should be constant through the log interval and should overlay. These curves deflect near casing collars. In sections of very good cement, the signal amplitude is low; detection may be affected by cycle skipping. GR is used for correlation purposes, and CCL serves as a reference for future cased hole correlations.
- Track 2
 - CBL measured in millivolts from the fixed gate should be equal to CBSL measured from the sliding gate, except in cases of cycle skipping or detection on noise.
- Track 3
 - VDL is a presentation of the acoustic waveform at a receiver of a sonic measurement. The amplitude is presented in shades of a gray scale. The VDL should show good contrast. In free pipe, it should be straight lines with chevron patterns at the casing collars. In a good bond, it should be gray (low amplitudes) or show strong formation signals (wavy lines).

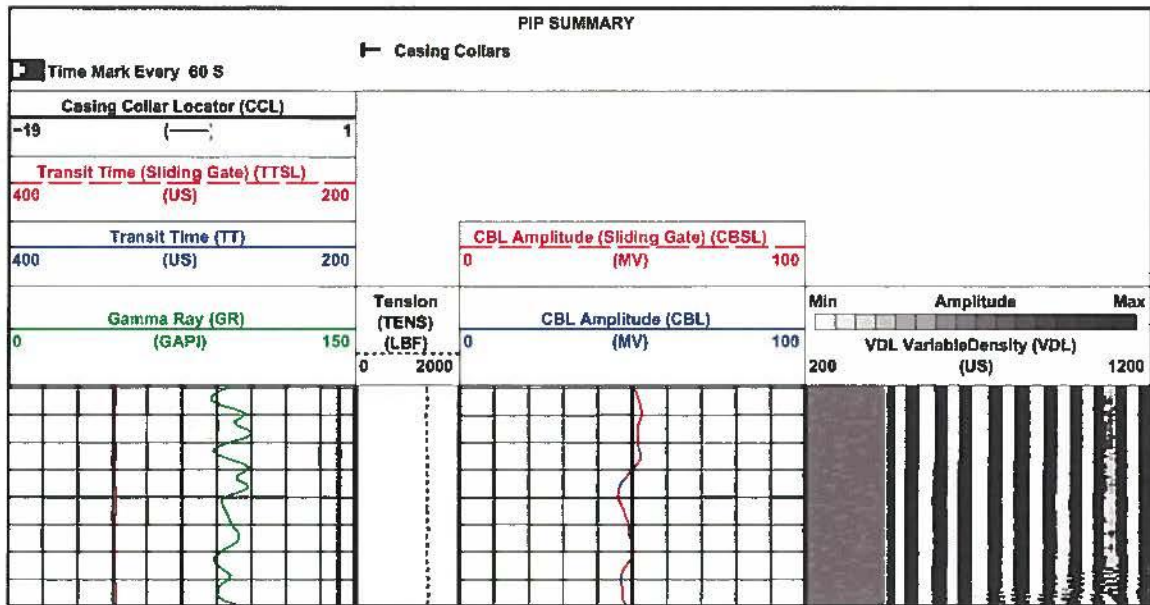

Figure 1. DSLT standard format.

Response in known conditions

The responses in Table 2 are for clean, free casing.

Table 2. Typical CBL Response in Known Conditions

| Casing OD, in | Weight, lbm/ft | Nominal Casing ID, in | CBL Amplitude Response in Free Pipe, mV |
|---------------|----------------|-----------------------|---|
| 5 | 13 | 4.494 | 77 ± 8 |
| 5.5 | 17 | 4.892 | 71 ± 7 |
| 7 | 23 | 6.366 | 62 ± 6 |
| 8.625 | 36 | 7.825 | 55 ± 6 |
| 9.625 | 47 | 8.681 | 52 ± 5 |
| 10.75 | 51 | 9.850 | 49 ± 5 |
| 13.375 | 61 | 12.515 | 43 ± 4 |
| 18.625 | 87.5 | 17.755 | 35 ± 4 |

USI

Overview

The USI* ultrasonic imager tool (USIT) uses a single transducer mounted on an Ultrasonic Rotating Sub (USRS) on the bottom of the tool. The transmitter emits ultrasonic pulses between 200 and 700 kHz and measures the received ultrasonic waveforms reflected from the internal and external casing interfaces. The rate of decay of the waveforms received indicates the quality of the cement bond at the cement-to-casing interface, and the resonant frequency of the casing provides the casing wall thickness required for pipe inspection.

Because the transducer is mounted on the rotating sub, the entire circumference of the casing is scanned. This 360° data coverage enables evaluation of the quality of the cement bond as well as determination of the internal and external casing condition. The very high angular and vertical resolutions can detect channels as narrow as 1.2 in [3.05 cm]. Cement bond, thickness, internal and external radii, and self-explanatory maps are generated in real time at the wellsite.

Specifications

| Measurement Specifications | |
|---|---|
| Output | Acoustic impedance, cement bonding to casing, internal radius, casing thickness |
| Logging speed | 400 to 3,600 ft/h [†] [122 to 1,097 m/h] |
| Range of measurement | Acoustic impedance: 0 to 10 Mrayl [0 to 10 MPa.s/m] |
| Vertical resolution | Standard: 6 in [15.24 cm] |
| Accuracy | Less than 3.3 Mrayl: ±0.5 Mrayl |
| Depth of investigation | Casing-to-cement interface |
| Mud type or weight limitations [‡] | Water-base mud: Up to 15.9 lbm/galUS Oil-base mud: Up to 11.2 lbm/galUS |
| Combinability | Bottom-only tool, combinable with most tools |
| Special applications | Identification and orientation of narrow channels |

[†] Speed depends on the resolution selected

[‡] Exact value depends on the type of mud system and casing size

Calibration

There is no calibration for the USI tool. The fluid properties measurement (FPM) of the wellbore fluid impedance (AIBK) and the fluid slowness (FVEL) is used for early input into the impedance model. The thickness of the subassembly reference plate (THBK) is also measured and output with FPM. FPM is recorded versus time while running in hole and output both as a time-depth log and as crossplots of FVEL versus depth and AIBK versus depth.

A before-survey tool check is conducted to verify basic tool operation.

| Mechanical Specifications | |
|---------------------------|------------------------|
| Temperature rating | 350 degF [177 degC] |
| Pressure rating | 20,000 psi [138 MPa] |
| Casing size—min. | 4½ in [11.43 cm] |
| Casing size—max. | 13¾ in [33.97 cm] |
| Outside diameter | 3.375 in [8.57 cm] |
| Length [†] | 19.75 ft [6.02 m] |
| Weight [†] | 333 lbm [151 kg] |
| Tension | 40,000 lbf [177,930 N] |
| Compression | 4,000 lbf [17,790 N] |

[†] Excluding the rotating sub

Tool quality control

Standard curves

The USI standard curves are listed in Table 1.

Table 1. USI Standard Curves

| Output Mnemonic | Output Name |
|-----------------|---|
| AIBK | Acoustic impedance fluid properties measurement (FPM) |
| AVMN | Minimum amplitude |
| AWAZ | Average amplitude |
| AWMX | Maximum amplitude |
| AZEC | Azimuth of eccentricity |
| ECCE | Tool eccentricity |
| ERAV | Average external radius |
| ERMN | Minimum external radius |
| ERMX | Maximum external radius |
| FVEL | Fluid acoustic slowness |
| FVEM | Fluid velocity FPM |
| GNMN | Minimum value of automatic gain (UPGA) in 6-in interval |
| GNMX | Maximum value of UPGA in 6-in interval |
| HRTT | Transit-time (TT) histogram |
| IDQC | Internal diameter quality check |
| IRAV | Average internal radius |
| IRMN | Minimum internal radius |
| IRMX | Maximum internal radius |
| THAV | Average thickness |
| THBK | Reference plate thickness FPM |
| THMN | Minimum thickness |
| THMX | Maximum thickness |
| USBI | Ultrasonic bond index |
| USGI | Ultrasonic gas index |
| WDMN | Waveform delay minimum |
| WDMX | Waveform delay maximum |
| WPKA | Waveform peak amplitude histogram |

Operation

The USI tool should be run centered. The tool has centralizers in its sonde. Eccentering should be less than 0.02 in [0.508 mm] per inch of casing diameter.

In deviated wells, knuckle joints must be used along with centralizers on tools above in the string.

Cement information is critical for setting the USIT field parameters.

Formats

The format in Fig. 1 is used mainly as a quality control.

- Track 1
 - The WPKA histogram is a distribution of the waveform measured by the USIT transducer. The image scale and color represents the number of samples and their corresponding peak amplitude in binary bits.
- Track 2
 - IDQC should match the actual casing internal diameter.
 - WDMN and WDMX should be within 10 us of each other. The difference is due to casing deformation or tool eccentricity.
- Track 3
 - GNMN and GNMX are the maximum and minimum gains, respectively, in the depth frame and should range between 0 and 10 dB.
- Track 4
 - The HRTT image represents the histogram of the TT measurements on a black background, which corresponds to the positions of the peak detection window. The coherence in the log track is desired; most of the echoes should be inside the window. Measured transit times should be well within the peak detection window in a good hole. If the blue color is out of the detection windows, parameters must be adjusted on the job to the windows.

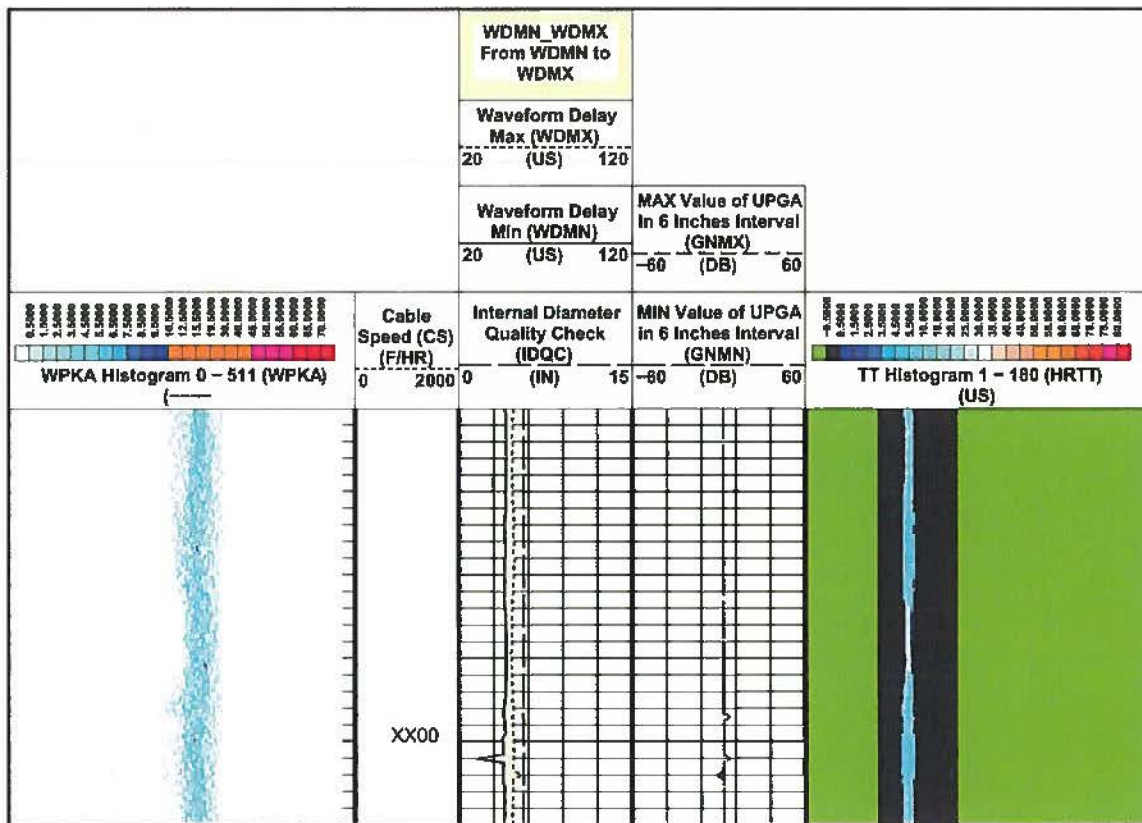

Figure 1. USIT standard format.

Response in known conditions

- The average internal radius and thickness measured by the tool should match the actual nominal internal radius of the casing.
- The expected responses in the measurement mode are listed in Table 2.

Table 2. Typical USI Response in Known Conditions

| Formation | Acoustic Impedance, Mrayl |
|--|---------------------------|
| Free gas or gas microannulus | <0.3 |
| Fresh water | 1.5 |
| Drilling fluids | 1.5 to 3.0 |
| Cement slurries | 1.8 to 3.0 |
| LITEFIL* cement (1.4 g/cm ³) | 3.7 to 4.3 |
| Neat cement (1.9 g/cm ³) | 6.0 to 8.4 |

ATTACHMENT D: INJECTION WELL PLUGGING PLAN

Facility Information

Facility name: Archer Daniels Midland, CCS#2 Well
IL-115-6A-0001
4666 Faries Parkway, Decatur, IL

Well location: Decatur, Macon County, IL;
39° 53' 09.32835", 88°53'16.68306"

Injection well plugging and abandonment will be conducted according to the procedures below, which are based on information submitted by ADM in May of 2016.

Upon completion of the project, or at the end of the life of the CCS #2 injection well, the well will be plugged and abandoned to meet the requirements at 40 CFR 146.92. The plugging procedure and materials will be designed to prevent any unwanted fluid movement, to resist the corrosive aspects of carbon dioxide/water mixtures, and to protect any USDWs. Any necessary revisions to the well plugging plan to address new information collected during logging and testing of the well will be made after construction, logging and testing of the well have been completed. The final plugging plan will be submitted to the UIC Program Director.

After injection has ceased, the well will be flushed with a kill weight brine fluid. A minimum of three tubing volumes will be injected without exceeding fracture pressure. Bottom hole pressure measurements will be made and the well will be logged and pressure tested to ensure mechanical integrity inside and outside the casing prior to plugging. If a loss of mechanical integrity is discovered, the well will be repaired prior to proceeding with the plugging operations. Detailed plugging procedure is provided below. All casing in this well will be cemented to surface at the time of construction and will not be retrievable at abandonment. After injection is terminated permanently, the injection tubing and packer will be removed. After the tubing and packer are removed, the balanced-plug placement method will be used to plug the well. If, after flushing, the tubing and packer cannot be released, an electric line with tubing cutter will be used to cut off the tubing above the packer and the packer will be left in the well, and the cement retainer method will be used for plugging the injection formation below the abandoned packer.

All of the casing strings will be cut off at least 3 feet below the surface, below the plow line. A blanking plate with the required permit information will be welded to the top of the cutoff casing.

Planned Tests or Measures to Determine Bottom-hole Reservoir Pressure

ADM will record bottom hole pressure from a down hole pressure gauge and calculate kill fluid density.

Planned External Mechanical Integrity Test(s)

ADM will conduct at least one of the following tests to verify external MI prior to plugging the injection well as required in 40 CFR 146.92(a).

| Test Description | Location |
|-----------------------|---|
| Temperature Log | Along wellbore using DTS or wireline well log |
| Noise Log | Wireline Well Log |
| Oxygen Activation Log | Wireline Well Log |

Information on Plugs

The cement(s) formulated for plugging will be compatible with the carbon dioxide stream. The cement formulation and required certification documents will be submitted to the agency with the well plugging plan. The operator will report the wet density and will retain duplicate samples of the cement used for each plug. Figure 1 presents a plugging schematic.

| | Plug #1 | Plug #2 | Plug #3 | Plug #4 | Plug #5 | Plug #6 | Plug #7 |
|---|---------------------------|---------|---------|---------|---------|----------------|---------|
| Diameter of Boring in Which Plug Will be Placed (inches) | 8.681 | 8.835 | | | | | |
| Depth to Bottom of Tubing or Drill Pipe (ft) | 7100 | 4000 | | | | | |
| Sacks of Cement to be Used (each plug) | 1378 | 1443 | | | | | |
| Slurry Volume to be Pumped (cu. ft) | 1530 | 1703 | | | | | |
| Slurry Weight (lb/gal) | 15.9 | 15.9 | | | | | |
| Calculated Top of Plug (ft) | 4000 | Surf | | | | | |
| Bottom of Plug (ft) | 7100 | 4000 | | | | | |
| Type of Cement or Other Material | CO ₂ resistant | Class A | | | | | |
| Method of Emplacement (e.g., balance method, retainer method, or two-plug method) | | | | | | Balance Method | |

Narrative Description of Plugging Procedures

Notifications, Permits, and Inspections

Notifications, permits, and inspections procedures are planned to include:

1. In compliance with 40 CFR 146.92(c), notify the regulatory agency at least 60 days before plugging the well and provide updated plugging plan, if applicable.
2. Move-in (MI) Rig onto CCS #2 and rig up (RU). All CO₂ pipelines will be marked and noted with rig supervisor prior to MI.
3. Conduct and document a safety meeting.
4. Record bottom hole pressure from down hole gauge and calculate kill fluid density
5. Open up all valves on the vertical run of the tree and check pressures.
6. Test the pump and line to 2,500 psi. Fill tubing with kill weight brine (9.5 ppg or determined by bottom hole pressure measurement). Bleeding off occasionally may be necessary to remove all air from the system. Test casing annulus to 1000 psi and monitor as in annual MIT. If there is pressure remaining on tubing rig to pump down tubing and inject two tubing volumes of kill weight brine. Monitor tubing and casing pressure for 1 hour. If both casing and tubing are dead then nipple up blowout preventers (NU BOP's). Monitor casing and tubing pressures.
7. If the well is not dead or the pressure cannot be bled off of tubing, rig up (RU) slickline and set plug in lower profile nipple below packer. Circulate tubing and annulus with kill weight fluid until well is dead. After well is dead, nipple down tree, nipple up blow-out preventers (BOPs), and perform a function test. BOP's should have appropriate sized single pipe rams on top and blind rams in the bottom ram for tubing. Test pipe rams and blind rams to 250 psi low, 3,000 psi high. Test annular preventer to 250 psi low and 3,000 psi high. Test all Texas Iron Works (pressure valve), BOP's choke and kill lines, and choke manifold to 250 psi low and 3,000 psi high. NOTE: Make sure casing valve is open during all BOP tests. After testing BOPs pick up tubing string and unlatch seal assembly from seal bore. Rig slick line and lubricator back to well and remove X- plug from well. Rig to pump via lubricator and circulate until well is dead.
8. Pull out of hole with tubing laying it down. NOTE: Ensure that the well is over-balanced so there is no backflow due to formation pressure and there are at least 2 well control barriers in place at all times.
9. Pull seal assembly, pick up workstring, and trip in hole (TIH) with the packer retrieving tools. Latch onto the packer and pull out of hole laying down same. Next, confirm the well's mechanical integrity by performing one of the permitted external mechanical integrity tests presented in the table under "Planned External Mechanical Integrity Test(s)" above.

Contingency: If unable to pull seal assembly, RU electric line and make cut on tubing string just above packer. Note: Cut must be made above packer at least 5-10 ft MD. If unable to pull the packer, pull the work string out of hole and proceed to next step. If problems are noted, update cement remediation plan (if needed) and execute prior to plugging operations.
10. TIH with work string to total depth (TD). Keep the hole full at all times. Circulate the well and prepare for cement plugging operations.
11. The lower section of the well will be plugged using CO₂ resistant cement from TD around 7100 ft to around 1000ft above the top of the Eau Claire formation (to

approximately 4000 ft). This will be accomplished by placing plugs in 500 ft incremental lifts. Using a density of 15.9 ppg slurry with a yield of 1.11 cf/sk, approximately 1378 sacks of cement will be required. *Actual cement volume will depend upon actual weight of the casing within the plugged zone as well as the length of plug set as determined during the plugging operation.* It is anticipated that at least six plugs of 500 feet in length will be necessary. No more than two plugs will be set before cement is allowed to set and plugs verified by setting work string weight down onto the plug. (Calculations: Assume 47 lb/ft casing for this interval $3100\text{ft} \times .4110 \text{ cu ft/ft} \times 1.20 / 1.11 \text{ cu ft/sk} = 1378 \text{ sacks.}$)

12. Circulate the well and ensure it is in balance. Place tubing just above cement top from previous day. Mix and spot 500 ft balanced plug in 9 5/8 inch casing (approximately 180 sacks Class A/H mixed at 15.9 ppg with yield 1.18 cu ft/sk). Pull out of plug and reverse circulate tubing. Repeat this operation until a total of 8 plugs have been set. If plugs are well balanced then the reverse circulation step can be omitted until after each third plug. Lay down work string while pulling from well. If rig is working daylight only then pull 10 stands and rack back in derrick and reverse tubing before shutting down for night. After waiting overnight, trip back in hole and tag plug and continue. After ten plugs have been set pull tubing from well and shut in for 12 hours. Trip in hole with tubing and tag cement top. *Calculate volume for final plug.* Pull tubing back out of well. Nipple down BOPs and cut all casing strings below plow line (min 3 feet below ground level or per local policies/standards and ADM requirements). Trip in well and set final cement plug. Total of approximately 1443 sacks total cement used in all remaining plugs above 4000 feet. Lay down all work string, etc. Rig down all equipment and move out. Clean cellar to where a plate can be welded with well name onto lowest casing string at 3 feet, or as per permitting agency directive. (Calculations assume 40#/ft casing and no excess because this section is inside the intermediate casing $4000 \text{ ft} \times .4257 \text{ cu ft/ft} / 1.18 \text{ cu ft/sk} = 1443 \text{ sacks.}$)
13. The procedures described above are subject to modification during execution as necessary to ensure a plugging operation that protects worker safety and is effective to protect USDWs, and any significant modifications due to unforeseen circumstances will be described in the Plugging report. Complete plugging forms and send in with charts and all lab information to the regulatory agency as required by permit. Plugging report shall be certified as accurate by ADM and plugging contractor, and shall be submitted within 60 days after plugging is completed.

Figure 1. CCS#2 Injection Well Plugging Schematic

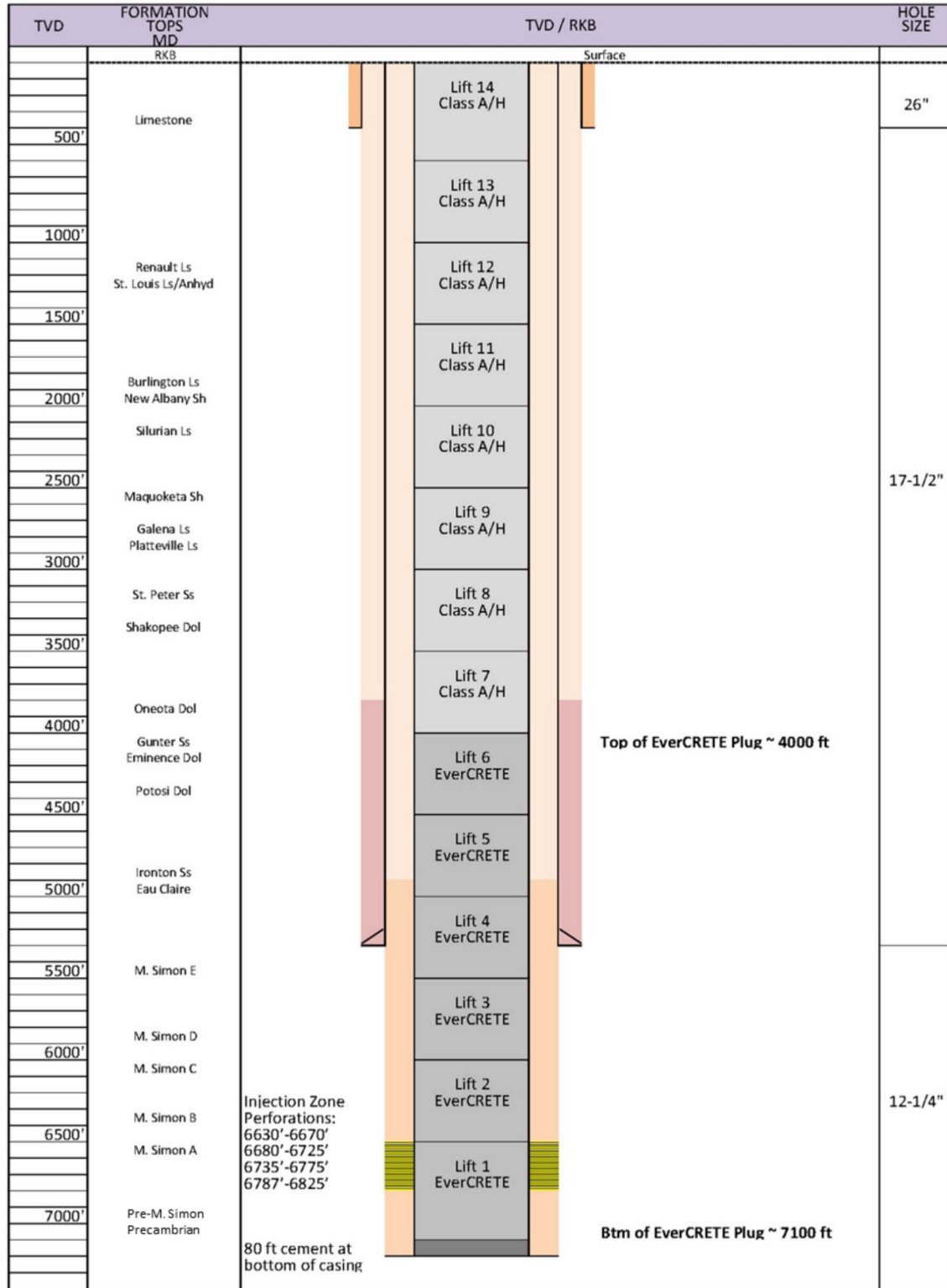

ATTACHMENT E: POST-INJECTION SITE CARE AND SITE CLOSURE PLAN

Facility Information

Facility name: Archer Daniels Midland, CCS#2 Well
IL-115-6A-0001
4666 Faries Parkway, Decatur, IL

Well location: Decatur, Macon County, IL;
39°53'09.32835", -88°53'16.68306"

This Post-Injection Site Care and Site Closure (PISC) plan describes the activities that ADM will perform to meet the requirements of 40 CFR 146.93. ADM will monitor groundwater quality and track the position of the carbon dioxide plume and pressure front for ten (10) years. This alternative post-injection site care timeframe was approved by EPA, but ADM may not cease post-injection monitoring until a demonstration of non-endangerment of USDWs has been approved by the Director pursuant to 40 CFR 146.93(b)(3). Following approval for site closure, ADM will plug all monitoring wells, restore the site to its original condition, and submit a Site Closure report and associated documentation.

Pre- and Post-Injection Pressure Differential

The formation pressure at the injection well is predicted to decline rapidly within the first 4 years following cessation of injection. Based on the modeling of the pressure front as part of the AoR delineation, pressure is expected to decrease to pre-injection levels by the end of the PISC timeframe. Additional information on the projected post-injection pressure declines and differentials is presented in the permit application and the Area of Review and Corrective Action Plan (Attachment B to this permit).

Predicted Position of the CO₂ Plume and Associated Pressure Front at Site Closure

Figure 1 shows the predicted extent of the plume and pressure front at the end of the 10 year PISC timeframe, representing the maximum extent of the plume and pressure front. This map is based on the final AoR delineation modeling results submitted in May 2016, per 40 CFR 146.84.

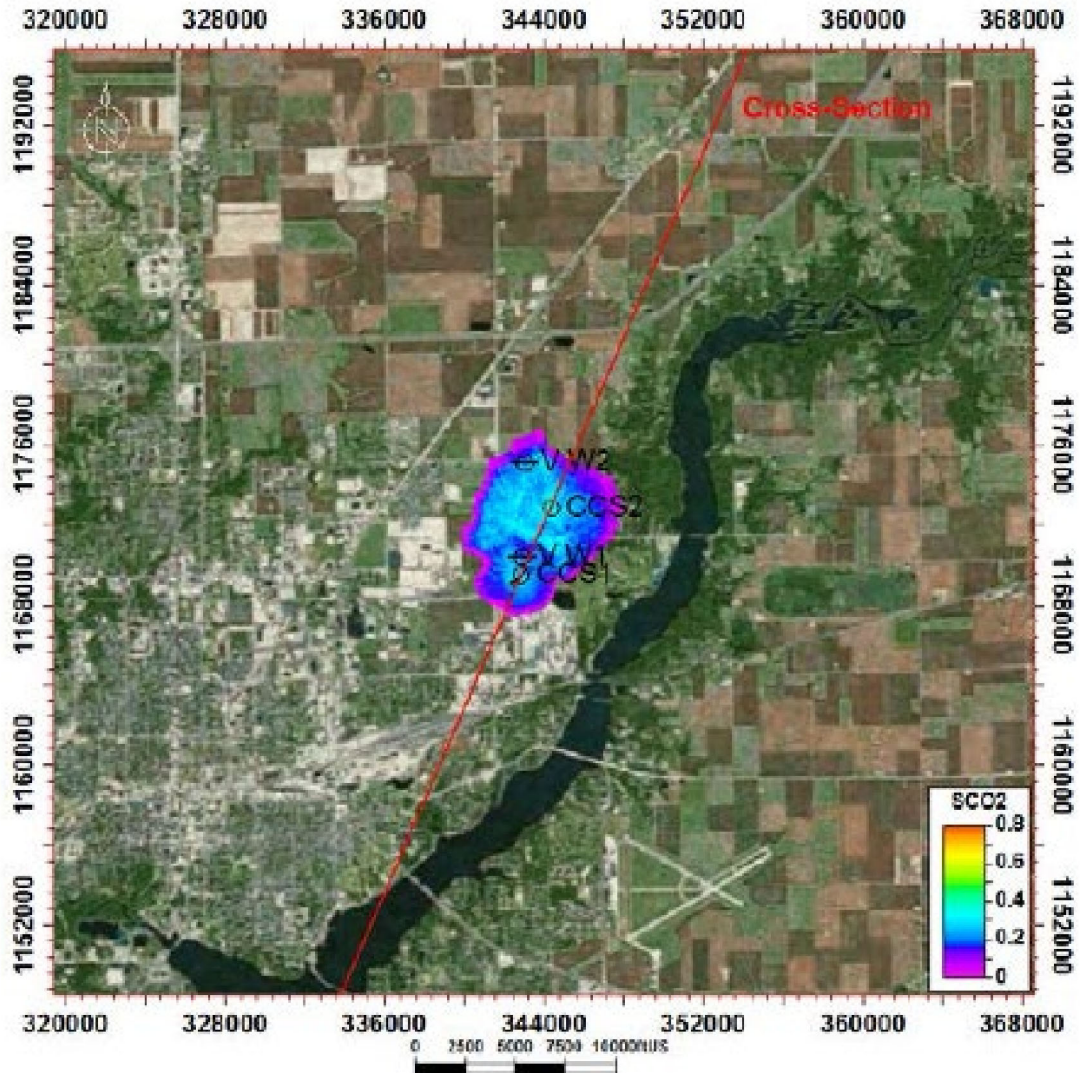

Figure 1. Predicted extent of the CO₂ plume 10 years after the cessation of injection (Est Yr 2031). Pressure front (DP_{if} = 62.2 psi) not shown because pressure is expected to decrease below that level at site closure.

Post-Injection Monitoring Plan

Performing groundwater quality monitoring and plume and pressure front tracking as described in the following sections during the post-injection phase will meet the requirements of 40 CFR 146.93(b)(1). The results of all post-injection phase testing and monitoring will be submitted annually, within 60 days of the anniversary date of the date on which injection ceases, as described under “Schedule for Submitting Post-Injection Monitoring Results,” below.

A quality assurance and surveillance plan (QASP) for all testing and monitoring activities during the injection and post injection phases is provided in the Appendix to the Testing and Monitoring Plan.

Groundwater Quality Monitoring

Table 1 and Table 2 present the planned direct and indirect monitoring methods, locations, and frequencies for groundwater quality monitoring above the confining zone in the Quaternary and/or Pennsylvanian strata, the St. Peter Formation, and the Ironton-Galesville Sandstone. All of the monitoring wells are located on ADM property. Table 3 identifies the parameters to be monitored and the analytical methods ADM will employ, and Figure 2 shows the locations of the monitoring wells.

Table 1. Post-Injection Phase Direct Groundwater Monitoring Above Confining Zone.^(1,2)

| Target Formation | Monitoring Activity | Monitoring Location(s) | Frequency: Year 1 | Frequency: Years 2-3 | Frequency: Years 4-9 | Frequency: Year 10 |
|--|---------------------------------------|--|--------------------------|-----------------------------|-----------------------------|---------------------------|
| Quaternary and/or Pennsylvanian strata | Fluid sampling | Shallow monitoring wells: MVA10LG, MVA11LG, MVA12LG, MVA13LG | Annual | Annual | Annual | Annual |
| | Distributed Temperature Sensing (DTS) | CCS#1 | Continuous | None | None | None |
| | | CCS#2 | Continuous | None | None | None |
| St. Peter | Fluid sampling | GM#2 | Annual | Annual | Annual | Annual |
| | Pressure/temperature monitoring | GM#2 | Continuous | Continuous | Annual | Annual |
| | DTS | CCS#1 | Continuous | None | None | None |
| | | CCS#2 | Continuous | None | None | None |
| Ironton-Galesville | Fluid sampling | VW#2 | Annual | Annual | Annual | Annual |
| | Pressure/temperature monitoring | VW#2 | Continuous | Continuous | Annual | Annual |
| | DTS | CCS#1 | Continuous | None | None | None |
| | | CCS#2 | Continuous | None | None | None |

Note 1: Collection and recording of continuous monitoring data will occur at the frequencies described in Table 4.

Note 2: Annual sampling and monitoring will occur up to 45 days before the anniversary date of cessation of injection or alternatively scheduled with the prior approval of the Director.

Table 2. Post-Injection Phase Indirect Groundwater Monitoring Above the Confining Zone⁽¹⁾

| Target Formation | Monitoring Activity | Monitoring Location(s) | Frequency: Year 1 | Frequency: Years 2-3 | Frequency: Years 4-9 | Frequency: Year 10 |
|--|----------------------------|-------------------------------|--------------------------|-----------------------------|-----------------------------|---------------------------|
| Quaternary and/or Pennsylvanian strata | Pulse Neutron Logging/RST | VW#1 | Year 1 | Year 3 | Year 5, Year 7 | Year 10 |
| | | VW#2 | Year 1 | Year 3 | Year 5, Year 7 | Year 10 |
| | | CCS#1 | Year 1 | Year 3 | Year 5, Year 7 | Year 10 |
| | | CCS#2 | Year 1 | Year 3 | Year 5, Year 7 | Year 10 |

| Target Formation | Monitoring Activity | Monitoring Location(s) | Frequency: Year 1 | Frequency: Years 2-3 | Frequency: Years 4-9 | Frequency: Year 10 |
|--------------------|---------------------------|------------------------|-------------------|----------------------|----------------------|--------------------|
| St. Peter | Pulse Neutron Logging/RST | VW#1 | Year 1 | Year 3 | Year 5, Year 7 | Year 10 |
| | | VW#2 | Year 1 | Year 3 | Year 5, Year 7 | Year 10 |
| | | CCS#1 | Year 1 | Year 3 | Year 5, Year 7 | Year 10 |
| | | CCS#2 | Year 1 | Year 3 | Year 5, Year 7 | Year 10 |
| Ironton-Galesville | Pulse Neutron Logging/RST | VW#1 | Year 1 | Year 3 | Year 5, Year 7 | Year 10 |
| | | VW#2 | Year 1 | Year 3 | Year 5, Year 7 | Year 10 |
| | | CCS#1 | Year 1 | Year 3 | Year 5, Year 7 | Year 10 |
| | | CCS#2 | Year 1 | Year 3 | Year 5, Year 7 | Year 10 |

Note 1: Logging surveys will occur within 45 days before the anniversary date of cessation of injection or alternatively scheduled with the prior approval of the Director.

Table 3. Summary of Analytical and Field Parameters for Groundwater Samples.

| Parameters | Analytical Methods ⁽¹⁾ |
|--|---|
| <i>Quaternary/Pennsylvanian</i> | |
| Cations: Al, Ba, Mn, As, Cd, Cr, Cu, Pb, Sb Se, and Tl | ICP-MS, EPA Method 6020 |
| Cations: Ca, Fe, K, Mg, Na, and Si | ICP-OES, EPA Method 6010B |
| Anions: Br, Cl, F, NO ₃ , and SO ₄ | Ion Chromatography, EPA Method 300.0 |
| Dissolved CO₂ | Coulometric titration, ASTM D513-11 |
| Total Dissolved Solids | Gravimetry; APHA 2540C |
| Alkalinity | APHA 2320B |
| pH (field) | EPA 150.1 |
| Specific conductance (field) | APHA 2510 |
| Temperature (field) | Thermocouple |
| <i>St. Peter</i> | |
| Cations: Al, Ba, Mn, As, Cd, Cr, Cu, Pb, Sb Se, and Tl | ICP-MS, EPA Method 6020 |
| Cations: Ca, Fe, K, Mg, Na, and Si | ICP-OES, EPA Method 6010B |
| Anions: Br, Cl, F, NO ₃ , and SO ₄ | Ion Chromatography, EPA Method 300.0 |
| Dissolved CO ₂ | Coulometric titration, ASTM D513-11 |
| Isotopes: δ ¹³ C of DIC | Isotope ratio mass spectrometry |
| Total Dissolved Solids | Gravimetry; APHA 2540C |

| Parameters | Analytical Methods ⁽¹⁾ |
|--|--|
| Water Density (field) | Oscillating body method |
| Alkalinity | APHA 2320B |
| pH (field) | EPA 150.1 |
| Specific conductance (field) | APHA 2510 |
| Temperature (field) | Thermocouple |
| <i>Ironton-Galesville</i> | |
| Cations: Al, Ba, Mn, As, Cd, Cr, Cu, Pb, Sb Se, and Tl | ICP-MS, EPA Method 6020 |
| Cations: Ca, Fe, K, Mg, Na, and Si | ICP-OES, EPA Method 6010B |
| Anions: Br, Cl, F, NO ₃ , and SO ₄ | Ion Chromatography, EPA Method 300.0 |
| Dissolved CO₂ | Coulometric titration, ASTM D513-11 |
| Isotopes: δ ¹³ C of DIC | Isotope ratio mass spectrometry |
| Total Dissolved Solids | Gravimetry; APHA 2540C |
| Water Density (field) | Oscillating body method |
| Alkalinity | APHA 2320B |
| pH (field) | EPA 150.1 |
| Specific conductance (field) | APHA 2510 |
| Temperature (field) | Thermocouple |

Note 1: ICP = inductively coupled plasma; MS = mass spectrometry; OES = optical emission spectrometry; GC-P = gas chromatography - pyrolysis. An equivalent method may be employed with prior approval of the Director.

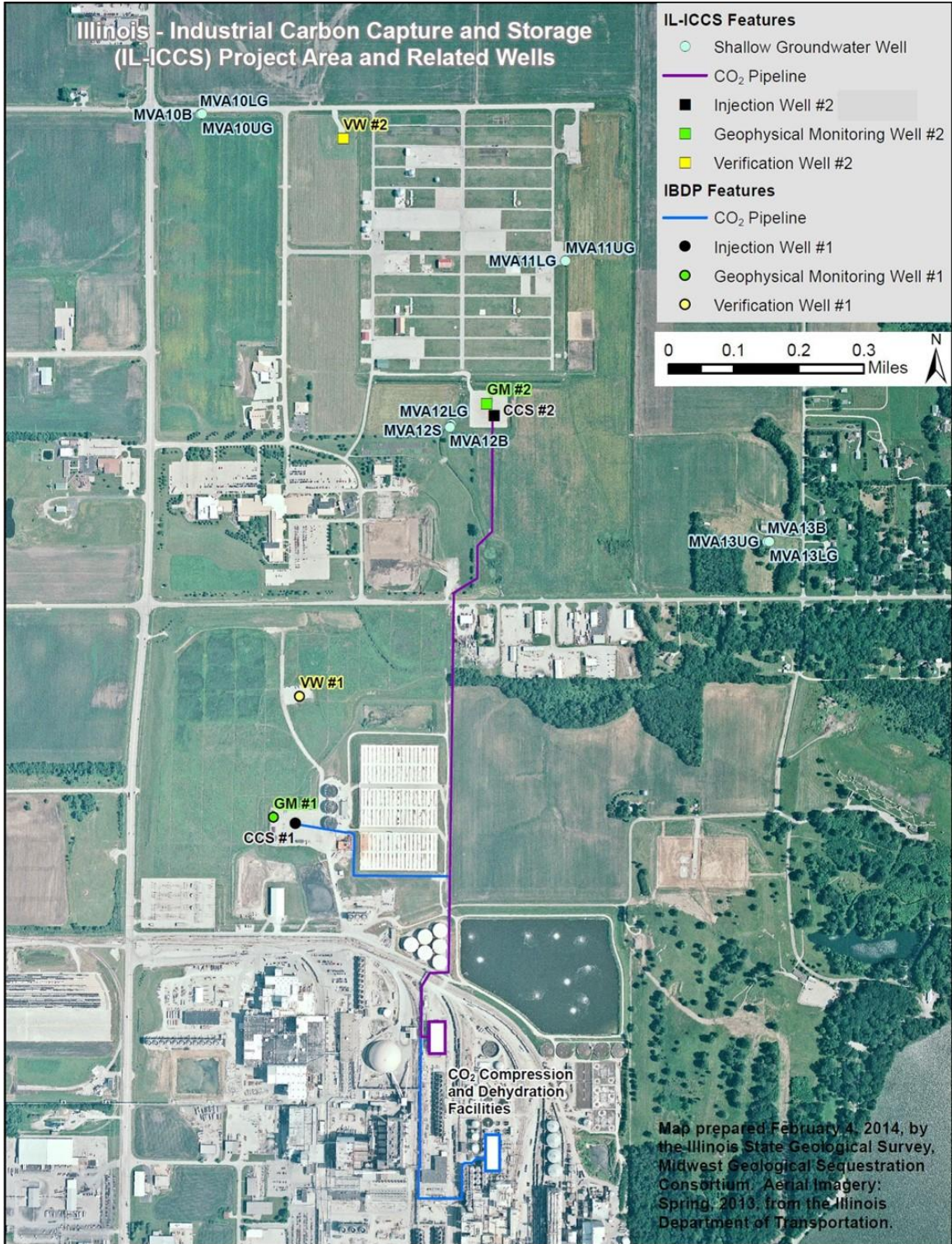

Figure 2. Location of shallow groundwater monitoring wells and deep monitoring wells.

Sampling will be performed as described in section B.2 of the QASP; this section of the QASP describes the groundwater sampling methods to be employed, including sampling SOPs (section B.2.a/b), and sample preservation (section B.2.g).

Sample handling and custody will be performed as described in section B.3 of the QASP.

Quality control will be ensured using the methods described in section B.5 of the QASP.

Collection and recording of continuous monitoring data will occur at the frequencies described in Table 4.

Table 4. Sampling and Recording Frequencies for Continuous Monitoring.

| Well Condition | Minimum sampling frequency: once every⁽¹⁾⁽⁴⁾ | Minimum recording frequency: once every⁽²⁾⁽⁴⁾ |
|--|--|---|
| For continuous monitoring of the injection well: | 5 seconds | 5 minutes ⁽³⁾ |
| For the well when shut-in: | 4 hours | 4 hours |

Note 1: Sampling frequency refers to how often the monitoring device obtains data from the well for a particular parameter. For example, a recording device might sample a pressure transducer monitoring injection pressure once every two seconds and save this value in memory.

Note 2: Recording frequency refers to how often the sampled information gets recorded to digital format (such as a computer hard drive). Following the same example above, the data from the injection pressure transducer might be recorded to a hard drive once every minute.

Note 3: This can be an average of the sampled readings over the previous 5-minute recording interval, or the maximum (or minimum, as appropriate) value identified over that recording interval.

Note 4: DTS sampling frequency is once every 10 seconds and recorded on an hourly basis.

Carbon Dioxide Plume and Pressure Front Tracking

ADM will employ direct and indirect methods to track the extent of the carbon dioxide plume and the presence or absence of elevated pressure.

Table 5 presents the direct and indirect methods that ADM will use to monitor the CO₂ plume, including the activities, locations, and frequencies ADM will employ. ADM will conduct fluid sampling and analysis to detect changes in groundwater in order to directly monitor the carbon dioxide plume. The parameters to be analyzed as part of fluid sampling in the Mt. Simon (and associated analytical methods) are presented in Table 6. Indirect plume monitoring will be employed using pulsed neutron capture/reservoir saturation tool (RST) logs to monitor CO₂ saturation and 3D surface seismic surveys. Quality assurance procedures for seismic monitoring methods are presented in Section B.9 of the QASP.

Table 5. Post-Injection Phase Plume Monitoring.^(1,2)

| Target Formation | Monitoring Activity | Monitoring Location(s) | Frequency: Year 1 | Frequency: Years 2-3 | Frequency: Years 4-9 | Frequency: Year 10 |
|---------------------------------------|----------------------------|-------------------------------|--------------------------|-----------------------------|-----------------------------|---------------------------|
| <i>Direct Plume Monitoring</i> | | | | | | |
| Mt. Simon | Fluid sampling | VW#2 | Annual | Annual | Annual | Annual |

| Target Formation | Monitoring Activity | Monitoring Location(s) | Frequency: Year 1 | Frequency: Years 2-3 | Frequency: Years 4-9 | Frequency: Year 10 |
|----------------------------------|---------------------------|---|--------------------------|----------------------|----------------------|---------------------------|
| Indirect Plume Monitoring | | | | | | |
| Mt. Simon | Pulse Neutron Logging/RST | VW#1 | Year 1 | Year 3 | Year 5, Year 7 | Year 10 |
| | | VW#2 | Year 1 | Year 3 | Year 5, Year 7 | Year 10 |
| | | CCS#1 | Year 1 | Year 3 | Year 5, Year 7 | Year 10 |
| | | CCS#2 | Year 1 | Year 3 | Year 5, Year 7 | Year 10 |
| | 3D surface seismic survey | Northern extent of plume area (fold coverage ~ 600 acres) | Once (Year 1) (Est 2020) | None | None | Once (Year 10) (Est 2030) |

Note 1: Sampling and geophysical surveys will occur within 45 days before the anniversary date of cessation of injection or alternatively scheduled with the prior approval of the Director.

Note 2: Seismic surveys will be performed in the 4th quarter before or the 1st quarter of the calendar year shown or alternatively scheduled with the prior approval of the Director.

Table 6. Summary of analytical and field parameters for fluid sampling in the Mt. Simon.

| Parameters | Analytical Methods ⁽¹⁾ |
|--|---|
| Cations: Al, Ba, Mn, As, Cd, Cr, Cu, Pb, Sb Se, and Tl | ICP-MS, EPA Method 6020 |
| Cations: Ca, Fe, K, Mg, Na, and Si | ICP-OES, EPA Method 6010B |
| Anions: Br, Cl, F, NO ₃ , and SO ₄ | Ion Chromatography, EPA Method 300.0 |
| Dissolved CO₂ | Coulometric titration, ASTM D513-11 |
| Isotopes: δ ¹³ C of DIC | Isotope ratio mass spectrometry |
| Total Dissolved Solids | Gravimetry; APHA 2540C |
| Water Density(field) | Oscillating body method |
| Alkalinity | APHA 2320B |
| pH (field) | EPA 150.1 |
| Specific conductance (field) | APHA 2510 |
| Temperature (field) | Thermocouple |

Note 1: ICP = inductively coupled plasma; MS = mass spectrometry; OES = optical emission spectrometry; GC-P = gas chromatography - pyrolysis. An equivalent method may be employed with the prior approval of the Director.

Table 7 presents the direct and indirect methods that ADM will use to monitor the pressure front, including the activities, locations, and frequencies ADM will employ. ADM will deploy pressure/temperature monitors and distributed temperature sensors to directly monitor the position of the pressure front. Passive seismic monitoring using a combination of borehole and surface seismic stations to detect local events over M 1.0 within the AoR will also be performed. Quality assurance procedures for seismic monitoring methods are presented in Section B.9 of the QASP.

Table 7. Post-Injection Phase Pressure Front Monitoring.^(1,2)

| Target Formation | Monitoring Activity | Monitoring Location(s) | Frequency: Year 1 | Frequency: Years 2-3 | Frequency: Years 4-9 | Frequency: Year 10 |
|---|---------------------------------------|--|------------------------|------------------------|------------------------|------------------------|
| Direct Pressure Front Monitoring | | | | | | |
| Mt. Simon | Pressure/temperature monitoring | VW#2 | Continuous 4 Intervals | Continuous 4 Intervals | Continuous 4 Intervals | Continuous 4 Intervals |
| | | CCS#1 | Continuous | Continuous | Annual | Annual |
| | | CCS#2 | Continuous | Continuous | Annual | Annual |
| | Distributed Temperature Sensing (DTS) | CCS#1 | Continuous | None | None | None |
| | | CCS#2 | Continuous | None | None | None |
| Other Monitoring | | | | | | |
| Multiple | Passive seismic | A combination of borehole and surface seismic stations located within the AoR. | Continuous | Continuous | Continuous | Continuous |

Note 1: Collection and recording of continuous monitoring data will occur at the frequencies described in Table 4.

Note 2: Annual monitoring surveys will occur up to 45 days before the anniversary date of cessation of injection or alternatively scheduled with the prior approval of the Director.

Monitoring locations relative to the predicted location of the CO₂ plume and pressure front at 5-year intervals throughout the post-injection phase are shown in Figure 3 through Figure 5. Predicted pressure profiles at the top of the injection interval and bottom-hole pressure at CCS#2 for 50 years after the commencement of injection are shown in Figure 6 and Figure 7. The predicted amount of CO₂ in the mobile gas, trapped gas, and dissolved (aqueous) phases for 50 years after the commencement of injection is shown in Figure 8.

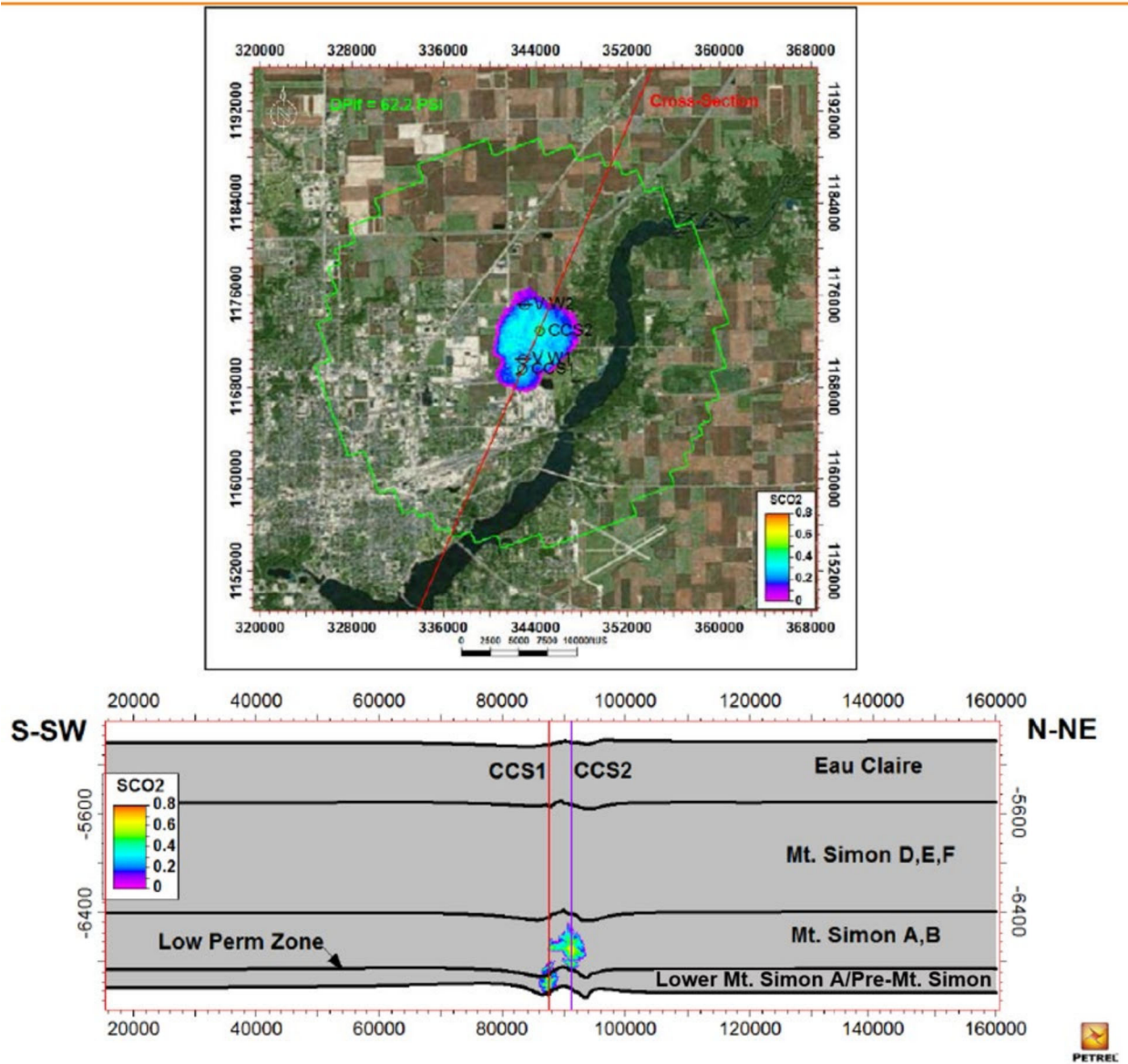

Figure 3. Predicted extent of the CO₂ plume and pressure front (DPif = 62.2 psi) relative to monitoring locations, at the beginning of the post-injection phase.

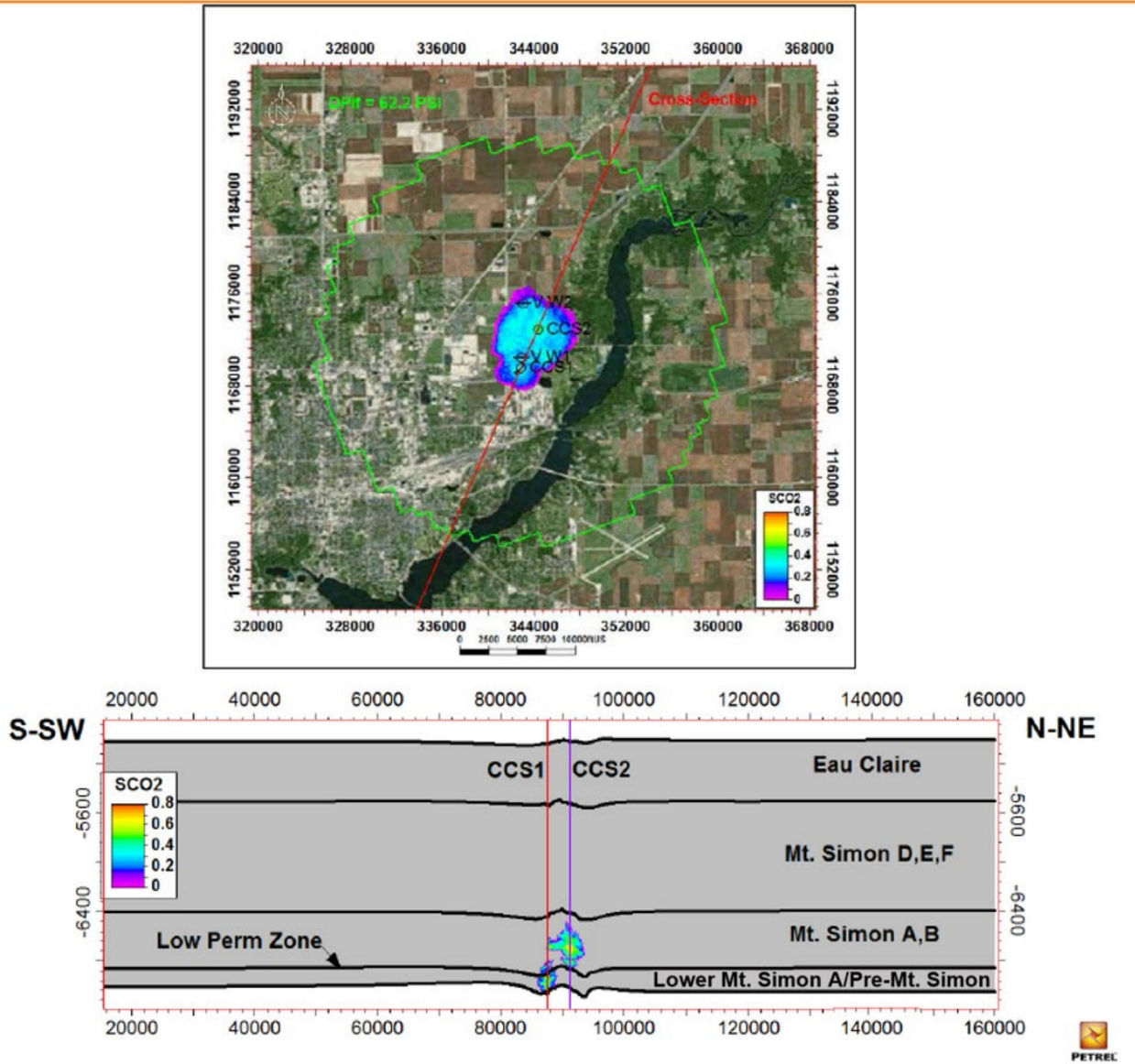

Figure 4. Predicted extent of the CO₂ plume and pressure front (DPif = 62.2 psi) relative to monitoring locations, at the end of 5 years after the cessation of injection.

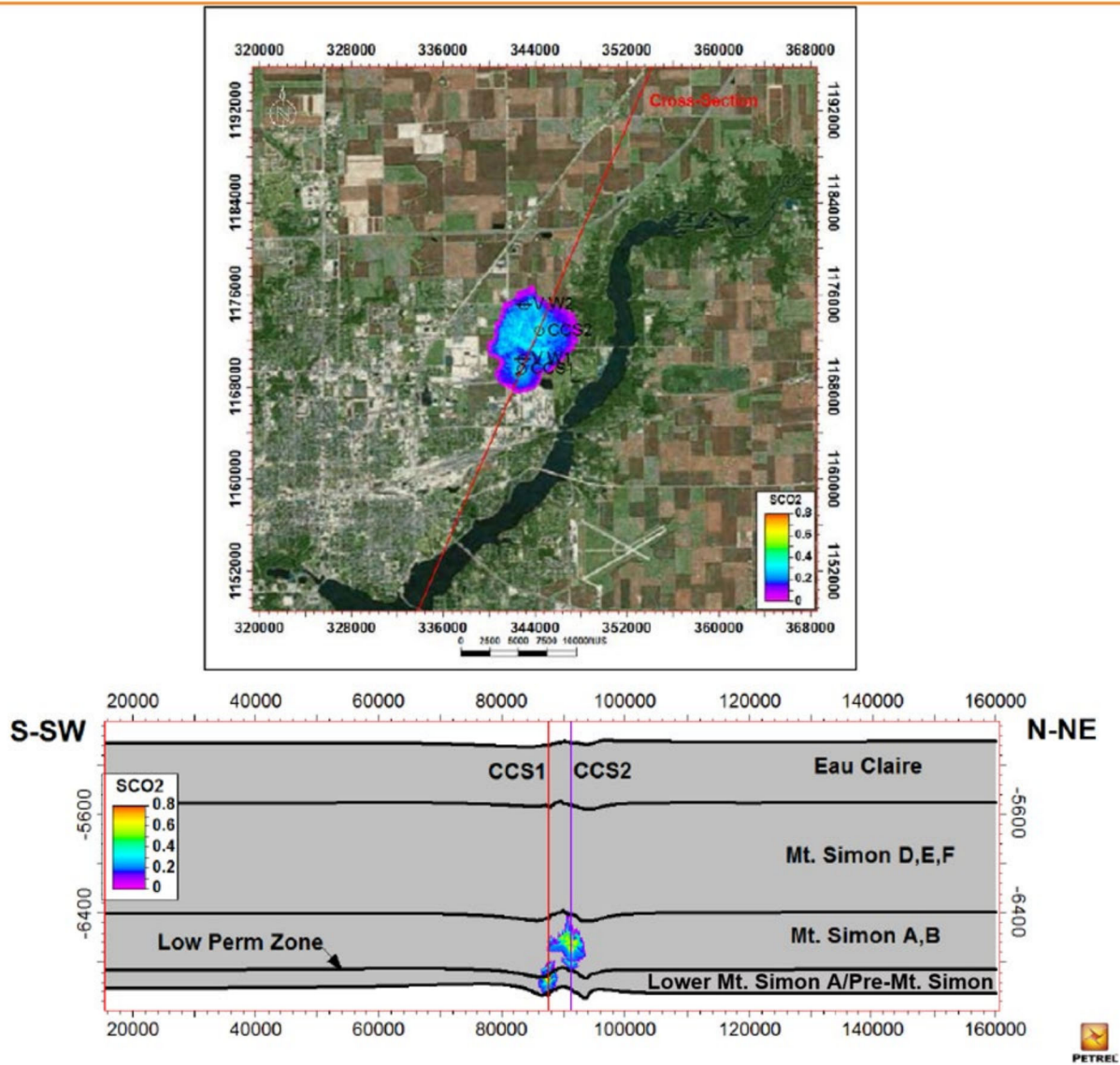

Figure 5. Predicted extent of the CO₂ plume and pressure front (DPif = 62.2 psi) relative to monitoring locations, at the end of 10 years after the cessation of injection (predicted time of site closure).

Pressure at Top of CCS2 Injection Interval

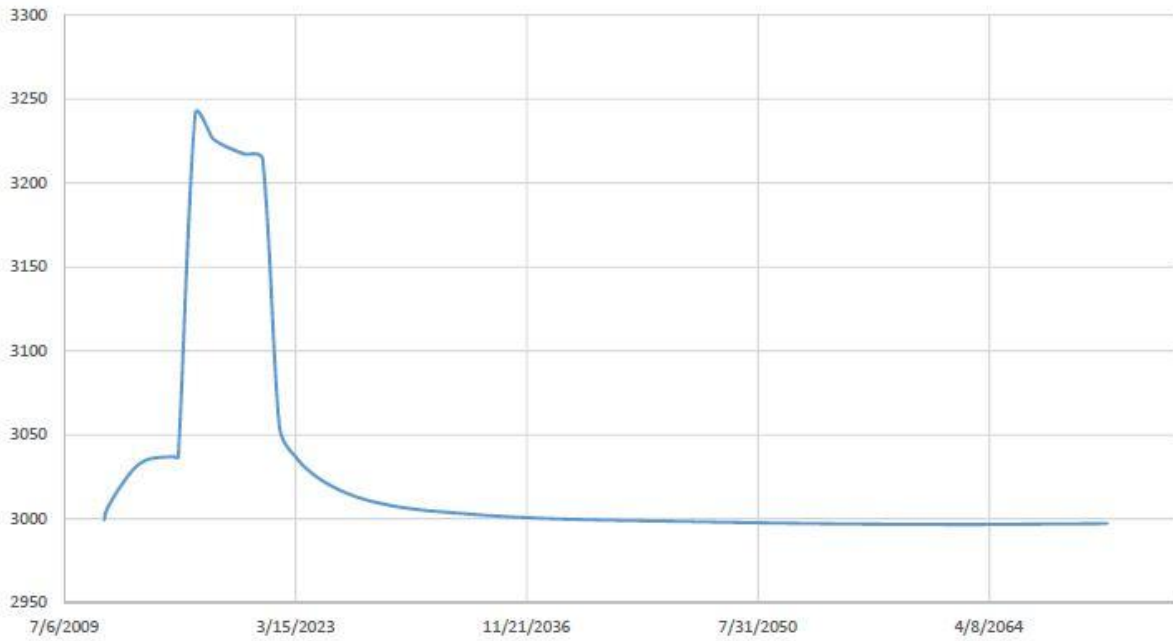

Figure 6. Predicted pressure profile at the top of the CCS#2 injection interval, simulated for 50 years after the commencement of injection.

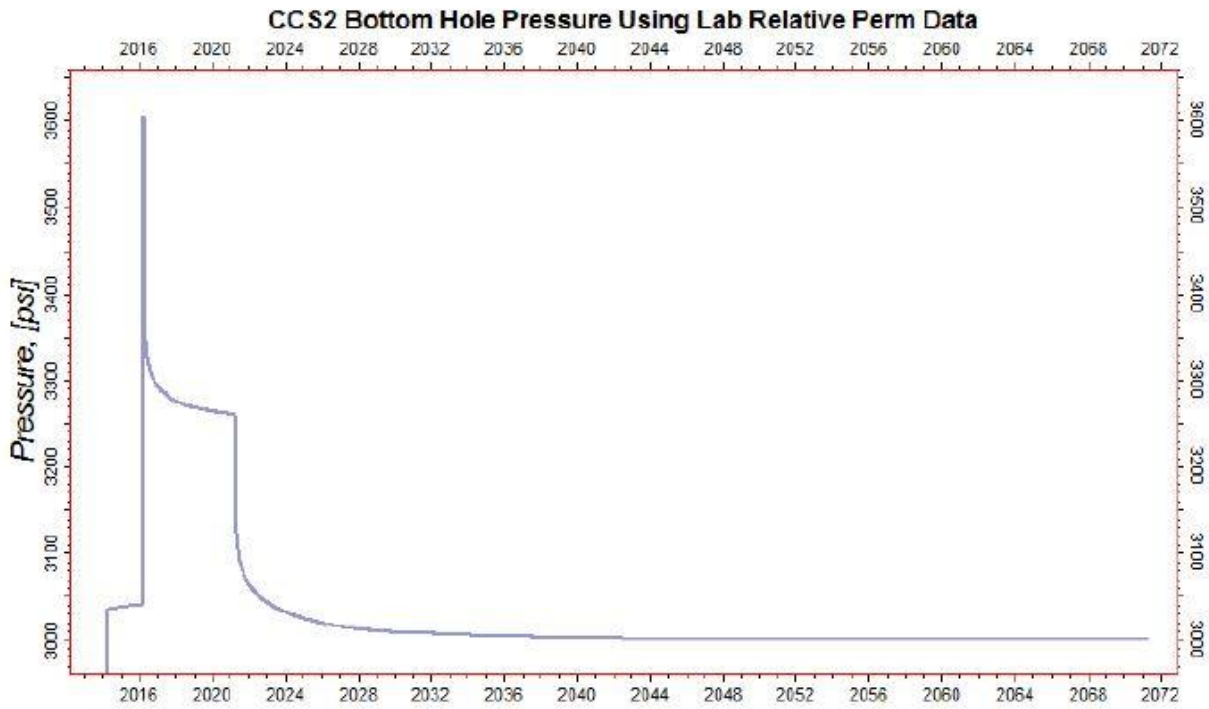

Figure 7. Predicted CCS#2 bottom-hole pressure profile, simulated for 50 years after the commencement of injection.

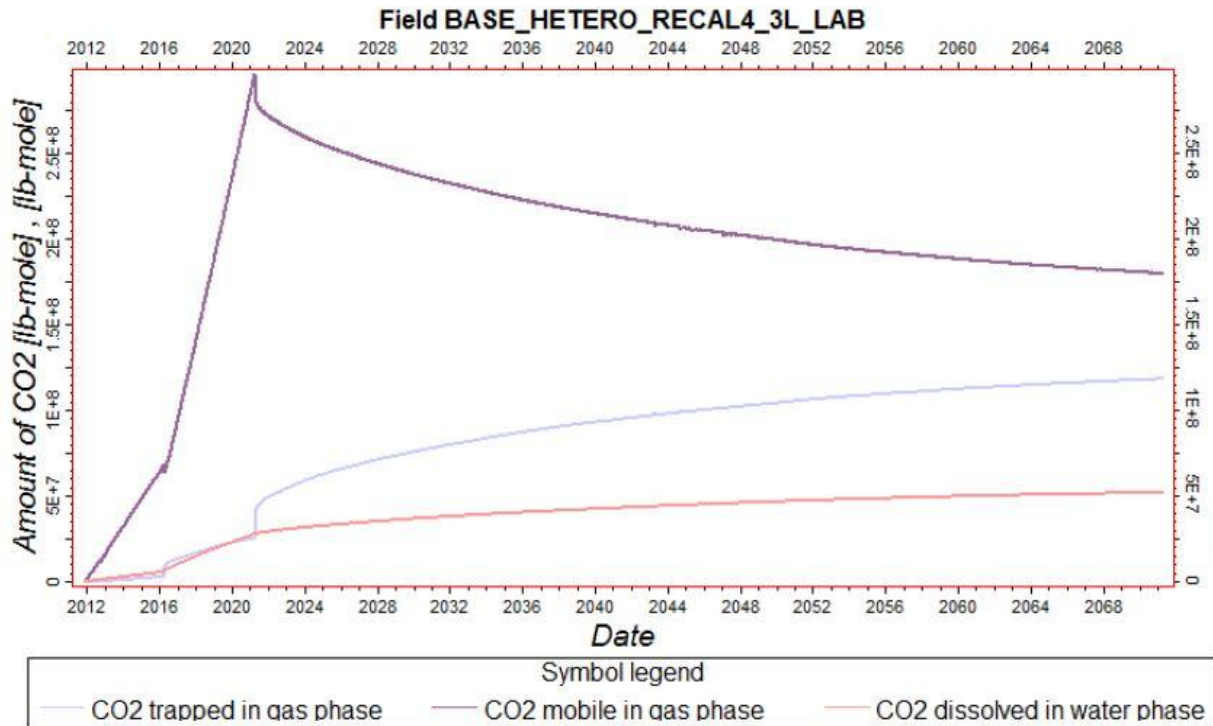

Figure 8. Predicted CO₂ phase distribution, simulated for 50 years after the commencement of injection.

Schedule for Submitting Post-Injection Monitoring Results

All post-injection site care monitoring data and monitoring results (i.e., resulting from the groundwater monitoring and plume and pressure front tracking described above) will be submitted to the Director in annual reports. These reports will be submitted each year, within 60 days following the anniversary date of the date on which injection ceases or alternatively with the prior approval of the Director.

The annual reports will contain information and data generated during the reporting period; i.e. seismic data acquisition, well-based monitoring data, sample analysis, and the results from updated site models.

Alternative Post-Injection Site Care Timeframe

ADM will conduct post-injection monitoring for ten years following the cessation of injection operations. ADM demonstrated that an alternative PISC timeframe is appropriate, pursuant to 40 CFR 146.93(c)(1). This demonstration is based on the computational modeling to delineate the AoR; predictions of plume migration, pressure decline, and carbon dioxide trapping; site-specific geology; well construction; and the distance between the injection zone and the nearest USDWs.

ADM will conduct all of the monitoring described under “Groundwater Quality Monitoring” and “Carbon Dioxide Plume and Pressure Front Tracking” above and report the results as described under the “Schedule for Submitting Post-Injection Monitoring Results.” This will continue until ADM demonstrates, based on monitoring and other site-specific data, that no additional

monitoring is needed to ensure that the project does not pose an endangerment to any USDWs, per the requirements at 40 CFR 146.93(b)(2) or (3).

If any of the information on which the demonstration was based changes or the actual behavior of the site varies significantly from modeled predictions, e.g., as a result of an AoR reevaluation, ADM may update this PISC and Site Closure Plan pursuant to 40 CFR 146.93(a)(4). ADM will update the PISC and Site Closure Plan, within six months of ceasing injection or demonstrate that no update is needed and as necessary during the duration of the PISC timeframe.

Non-Endangerment Demonstration Criteria

Prior to authorization of site closure, ADM will submit a demonstration of non-endangerment of USDWs to the Director, per 40 CFR 146.93(b)(2) or (3).

To make the non-endangerment demonstration, ADM will issue a report to the Director. This report will make a demonstration of USDW non-endangerment based on the evaluation of the site monitoring data used in conjunction with the project's computational model. The report will detail how the non-endangerment demonstration uses site-specific conditions to confirm and demonstrate non-endangerment. The report will include (or appropriately reference): all relevant monitoring data and interpretations upon which the non-endangerment demonstration is based, model documentation and all supporting data, and any other information necessary for the Director to review the analysis. The report will include the following components:

Summary of Existing Monitoring Data

A summary of all previous monitoring data collected at the site, pursuant to the Testing and Monitoring Plan (Attachment C of this permit) and this PISC and Site Closure Plan, including data collected during the injection and PISC phases of the project, will be submitted to help demonstrate non-endangerment. Data submittals will be in a format acceptable to the Director [40 CFR 146.91(e)], and will include a narrative explanation of monitoring activities, including the dates of all monitoring events, changes to the monitoring program over time, and an explanation of all monitoring infrastructure that has existed at the site. Data will be compared with baseline data collected during site characterization [40 CFR 146.82(a)(6) and 146.87(d)(3)].

Comparison of Monitoring Data and Model Predictions and Model Documentation

The results of computational modeling used for AoR delineation and for demonstration of an alternative PISC timeframe will be compared to monitoring data collected during the operational and the PISC period. The data will include the results of time-lapse temperature and pressure monitoring, groundwater quality analysis, passive seismic monitoring, and geophysical surveys (i.e. logging, operating-phase VSP, and 3D surface seismic surveys) used to update the computational model and to monitor the site. Data generated during the PISC period will be used to help show that the computational model accurately represents the storage site and can be used as a proxy to determine the plume's properties and size. The operator will demonstrate this degree of accuracy by comparing the monitoring data obtained during the PISC period against the model's predicted properties (i.e. plume location, rate of movement, and pressure decay). Statistical methods will be employed to correlate the data and

confirm the model's ability to accurately represent the storage site. The validation of the computational model with the large volume of available data will be a significant element to support the non-endangerment demonstration. Further, the validation of the complete model over the areas, and at the points, where direct data collection has taken place will help to ensure confidence in the model for those areas where surface infrastructure preclude geophysical data collection and where direct observation wells cannot be placed.

Evaluation of Carbon Dioxide Plume

The operator will use a combination of time-lapse RST logs, time-lapse VSP surveys, and other seismic methods (2D or 3D surveys) to locate and track the extent of the CO₂ plume. Figure 9, Figure 10, and Figure 11 present examples of how the data may be correlated against the model prediction. In Figure 9, a series of RST logs are compared against the model's predicted plume vertical extent at a specific point location at a specified time interval. A good correlation between the two data sets will help provide strong evidence in validating the model's ability to represent the storage system. Similarly, Figure 10 illustrates a comparison of the time-lapse VSPs against the predicted spatial extent of the plume at a specified time interval. Also, limited 2D and 3D seismic surveys will be employed to determine the plume location at specific times. The data produced by these activities will be compared against the model using statistical methods to validate the model's ability to accurately represent the storage site. Figure 11 presents an example of how the data from time-lapse 3D seismic surveys may be correlated against the model prediction.

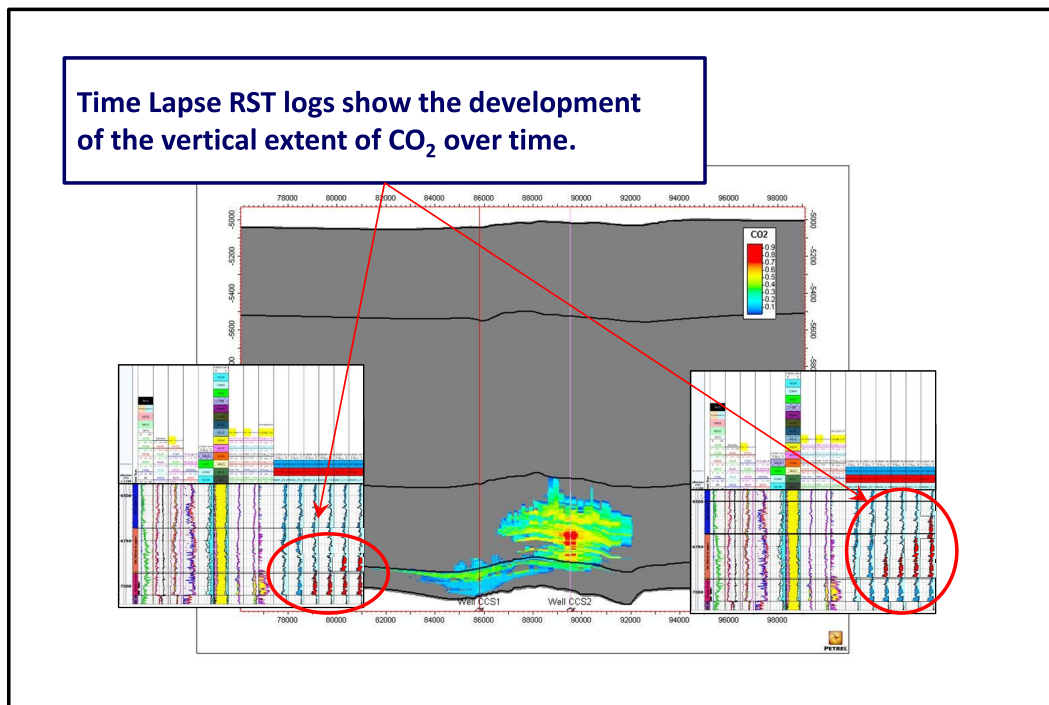

Figure 9. Comparison of the time-lapse RST logs against the predicted vertical extent of the plume at a specific time interval during the operational and PISC period can provide validation of the model's accuracy.

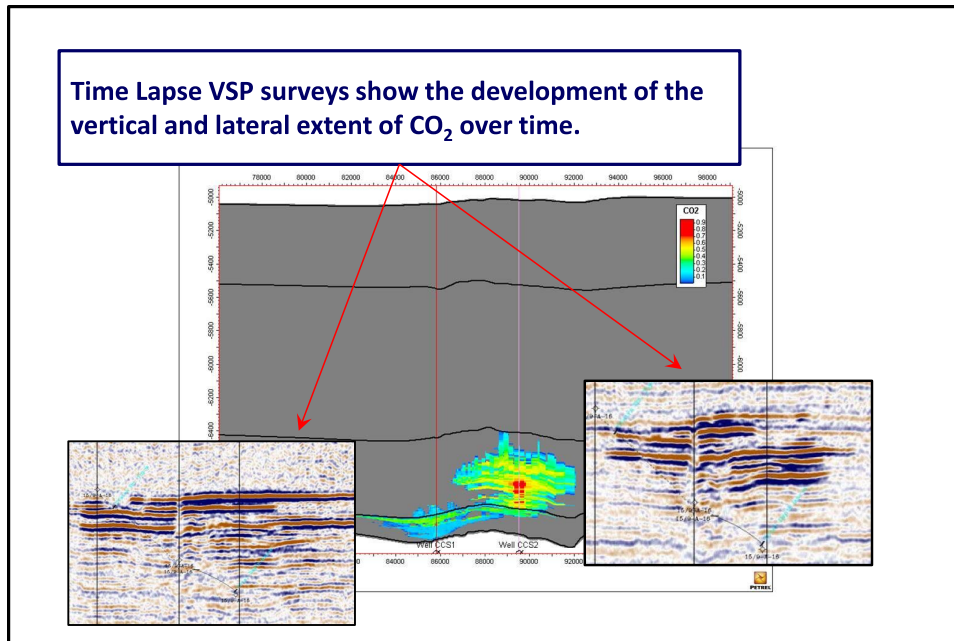

Figure 10. Comparison of the time-lapse VSPs against the predicted spatial extent of the plume at specific time intervals during the operational and PISC period can provide validation of the model's accuracy.

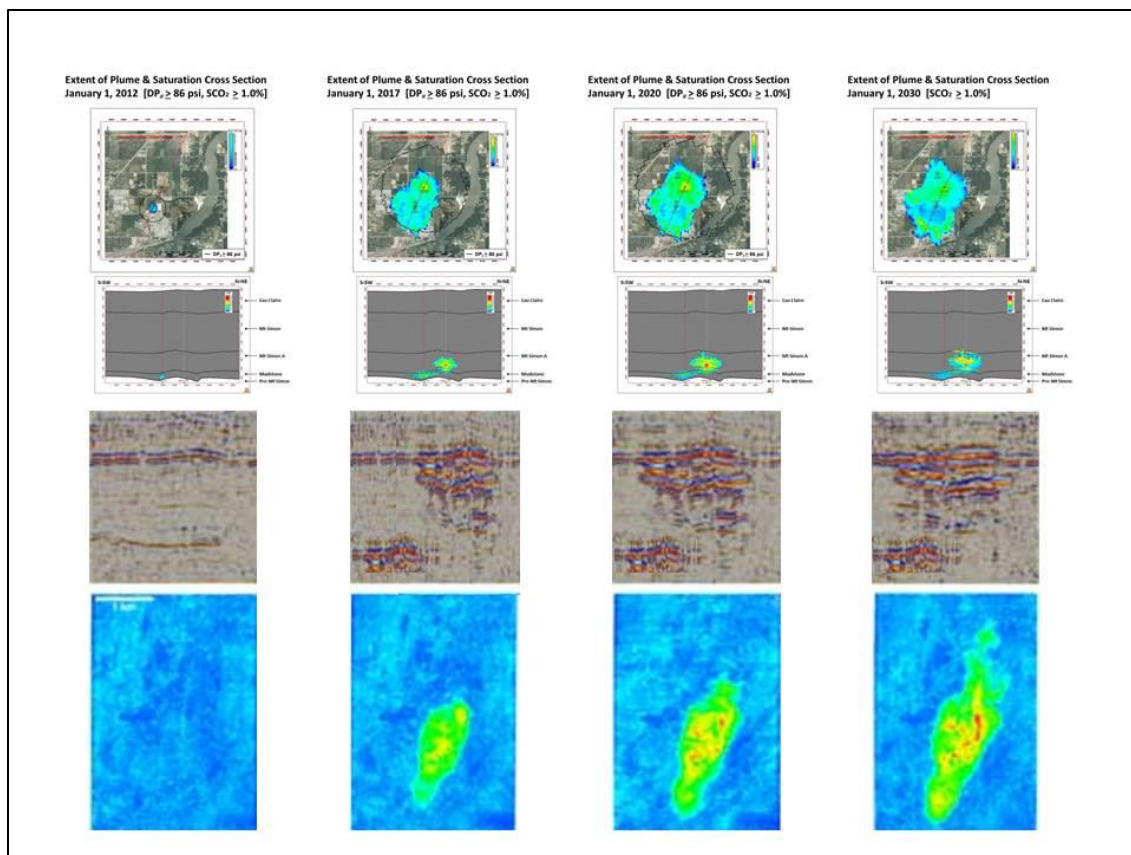

Figure 11. Comparison of the time-lapse surface 3D against the predicted spatial extent of the plume at specific time intervals during the operational and PISC period can provide validation of the model's accuracy.

Regarding the separate-phase carbon dioxide plume, the PISC monitoring data will be used to support a demonstration of the stabilization of the CO₂ plume as the reservoir pressure returns toward its pre-injection state. The storage interval (Mt. Simon) is considered to be an open reservoir system with a regional dip oriented NW (up-dip) to SE (down-dip) and having excellent porosity (20%) and permeability (120 mD). Locally, the storage interval has thin stratigraphic bands of low permeability siltstone to mudstone. These bands act as baffles that restrict the plume's vertical movement. Modeling performed to delineate the plume and pressure front predicts that, during the PISC period, the CO₂ will gradually rise through the reservoir until it encounters a baffle at which time it pools and spreads laterally. Based on the results of a 50 year post injection simulation, the top of the CO₂ plume is about 900 vertical feet below the primary seal formation (Eau Claire Shale). Additionally, the model predicts that over half the CO₂ will have become immobilized within the formation. This, in conjunction with the reservoir pressure returning to its pre-injection state, will be used to indicate there is essentially no driving force to cause significant plume movement. Indeed, the middle Mt. Simon contains intervals of eolian sandstone which are very tightly cemented by quartz overgrowths with some facies having permeabilities <0.01 mD. These intervals will act as more than a baffle and will significantly impede any vertical plume migration due to buoyancy forces.

The stabilization of the site conditions combined with the site's characteristic of not having any local penetrations of the seal formation will be the central focus of the operator's demonstration of non-endangerment. Equalization of plume to the site's pre-injection conditions will be one element in demonstrating non-endangerment. To demonstrate this, a case was examined to determine how long it would take a slowly expanding plume to reach the nearest penetration of the seal formation. Shown in Figure 15, the closest penetration of the seal formation is approximately 17 miles from the injection well. Assuming the plume continues to grow at 1% per year, it would take over 600 years for the plume to reach this plugged and abandoned well. Because this well is down dip from the injection well, it is likely the plume will never reach this location.

Evaluation of Mobilized Fluids

In addition to carbon dioxide, mobilized fluids may pose a risk to USDWs. These include native fluids that are high in TDS and therefore may impair a USDW, and fluids containing mobilized drinking water contaminants (e.g., arsenic, mercury, hydrogen sulfide). The geochemical data collected from monitoring wells will be used to demonstrate that no mobilized fluids have moved above the seal formation and therefore after the PISC period would not pose a risk to USDWs. In order to demonstrate non-endangerment, the operator will compare the operational and PISC period samples from layers above the injection zone, including the lowermost USDW, against the pre-injection baseline samples. This comparison will support a demonstration that no significant changes in the fluid properties of the overlying formations have occurred and that no mobilized formation fluids have moved through the seal formation. This validation of seal integrity will help demonstrate that the injectate and or mobilized fluids would not represent an endangerment to any USDWs.

Additionally, RST logs will be used to monitor the salinity of the reservoir fluids in the observation zone above the Eau Claire Shale seal. Figure 12 shows the relationship between salinity and sigma for two different temperatures while Table 8 shows the compositions of the

groundwater at various intervals. This table shows the difference between the salinity level of the Mt Simon and the Ironton-Galesville (the interval directly above the confining zone). By comparing the time lapse RST logs against the pre-injection baseline logs, the operator will be able to monitor any changes in reservoir fluid salinity. RST logs indicating steady salinity levels within each zone would indicate no movement of fluids out of the storage unit, confirming the integrity of the well and seal formation.

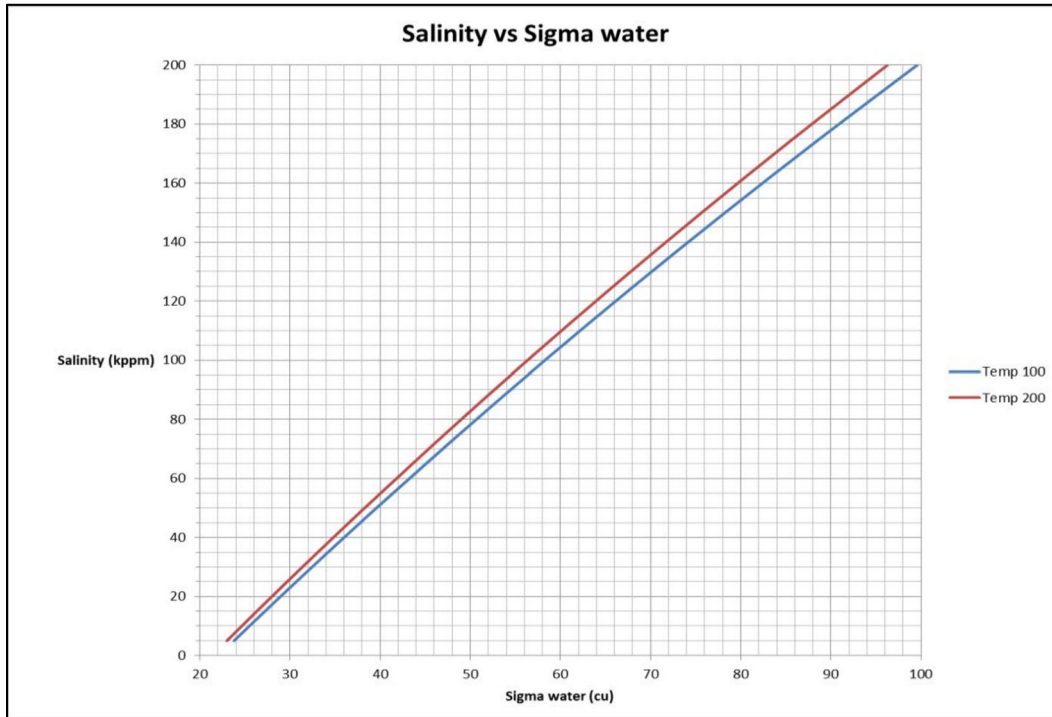

Figure 12. The red and blue lines show the relationship between salinity and sigma for at 100°F and 200°F.

Table 8. Fluid parameters for the Pennsylvanian, Ironton-Galesville, and Mt Simon.

| Constituent | Pennsylvanian | Ironton-Galesville | Mt. Simon |
|-------------------------|---------------|--------------------|-----------|
| Conductivity (mS/cm) | 1.5 | 80 | 170 |
| TDS (mg/L) | 1,000 | 65,600 | 190,000 |
| Cl ⁻ (mg/L) | 170 | 36,900 | 120,000 |
| Br ⁻ (mg/L) | 1 | 180 | 680 |
| Alkalinity (mg/L) | 380 | 130 | 80 |
| Na ⁺ (mg/L) | 140 | 17,200 | 50,000 |
| Ca ²⁺ (mg/L) | 100 | 5,200 | 19,000 |
| K ⁺ (mg/L) | 1 | 520 | 1,700 |
| Mg ²⁺ (mg/L) | 50 | 950 | 1,800 |
| pH (units) | 7.2 | 6.9 | 5.9 |

Evaluation of Reservoir Pressure

The operator will also support a demonstration of non-endangerment to USDWs by showing that, during the PISC period, the pressure within the Mt. Simon rapidly decreases toward its pre-injection static reservoir pressure. Because the increased pressure during injection is the primary driving force for fluid movement that may endanger a USDW, the decay in the pressure differentials will provide strong justification that the injectate does not pose a risk to any USDWs.

The operator will monitor the downhole reservoir pressure at various locations and intervals using a combination of surface and downhole pressure gauges. The measured pressure at a specific depth interval will be compared against the pressure predicted by the computational model. Agreement between the actual and the predicted values will help validate the accuracy of the model and further demonstrate non-endangerment. Figure 13 provides an illustrative example of how the operator will demonstrate agreement between the computational model prediction and the actual measured parameters at the various monitoring wells and respective measurement depths. This figure shows that during the 10 years of the PISC period, the actual reservoir pressure (red line) falls to pre-injection levels and has a decay rate similar to the rate predicted by the model. Based on risk-based criteria listed in the PISC and Site Closure Plan, pressure decline toward pre-injection levels is one factor indicative of USDW non-endangerment. The close alignment between the predicted and actual pressures will further validate the model's accuracy in representing the reservoir system.

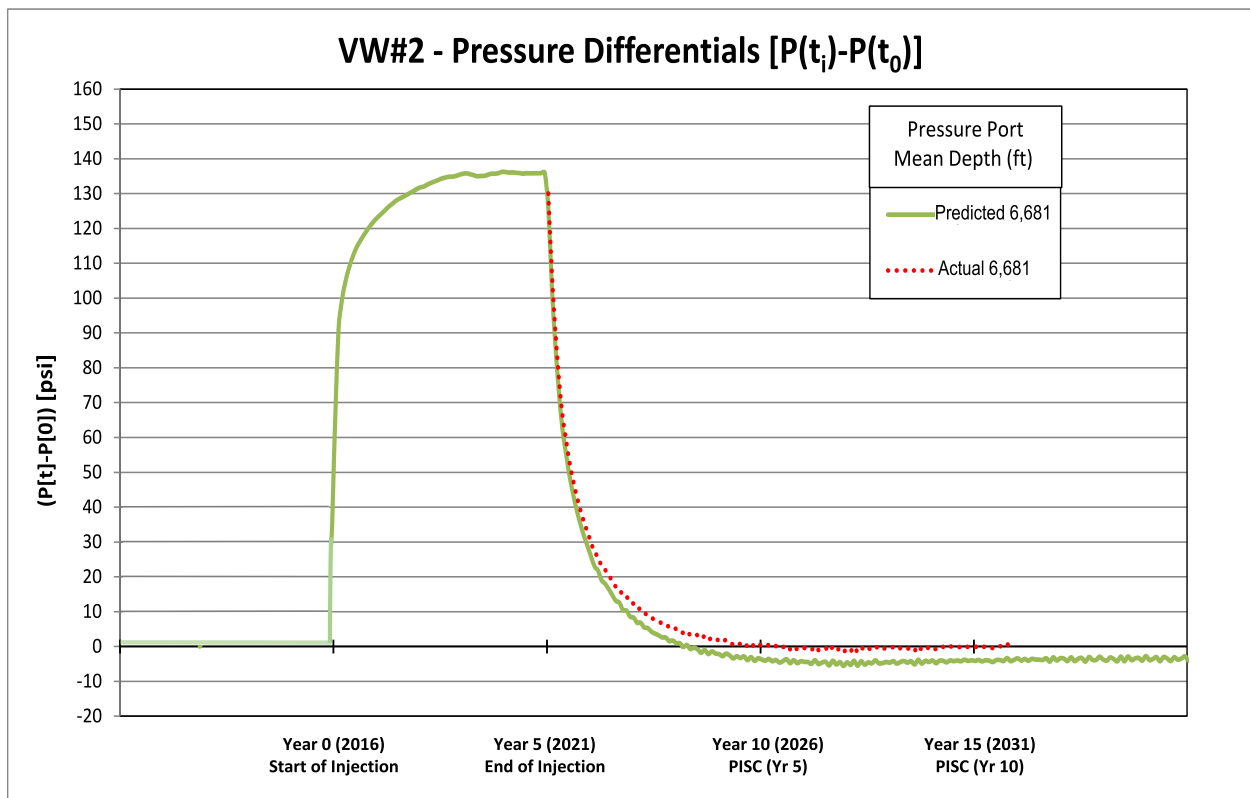

Figure 13. Illustration of Verification Well #2 comparison of actual dP versus the predicted monitoring interval dP during PISC period through year 2031.

One of the key comparisons that may be made is between the observed injection reservoir pressure and the model predicted pressure. Figure 14 shows an illustrative example of differential reservoir pressure predicted for three years after injection ceases, relative to original static reservoir pressure. The contour southwest of the CCS#2 well is the 10 psi contour as predicted by the computational model. Direct observations will be utilized during the PISC period to verify that pressure observations at CCS#2 have declined in conformance with the model. Pressure decline to this level within this time frame is an indication of the excellent lateral continuity within the regionally extensive, open Mt. Simon reservoir. Observed reduction of reservoir pressure to this extent would help validate the model and indicate substantial reduction in the potential of injection-pressure induced brine or CO₂ migration.

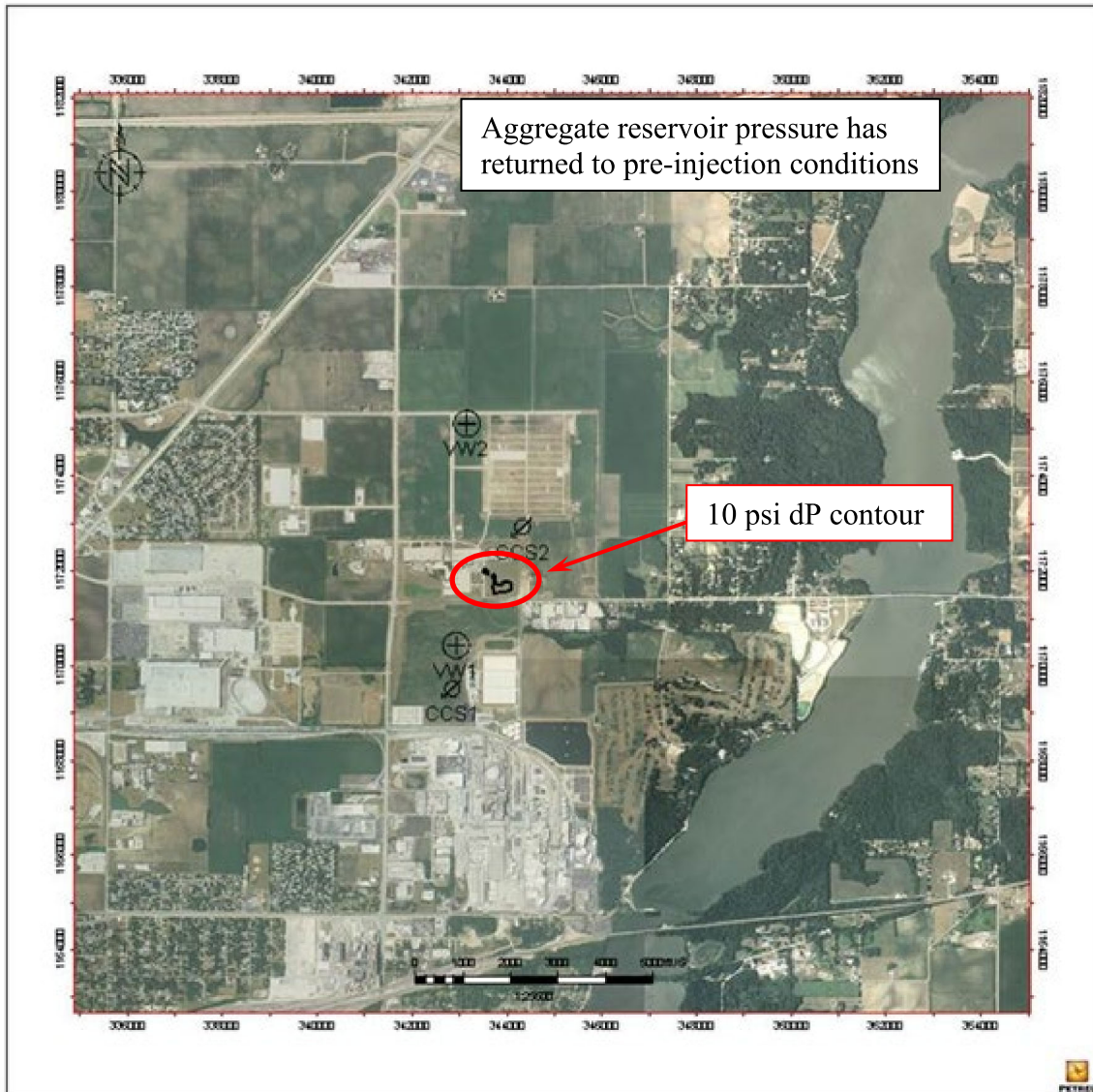

Figure 14. Example of how direct pressure measurements at CCS#1, CCS#2, & VW#2 will support the 10 psi differential pressure contour as predicted by the flow model (inside red circle), shown at April 1, 2024.

Evaluation of Potential Conduits for Fluid Movement

Other than the project wells, there are no identified potential conduits for fluid movement or leakage pathways within the AoR. As shown in Figure 15, the closest penetration of the confining zone is approximately 17 miles from the injection well. Based on the computational model, if the plume were to continue to grow at 1% per year it would take over 600 years for the plume to reach this well. Because this well is down dip from the injection well, it is likely the plume will never reach this location. Based on this information, the potential for fluid movement through artificial penetrations of the seal formation does not present a risk of endangerment to any USDWs.

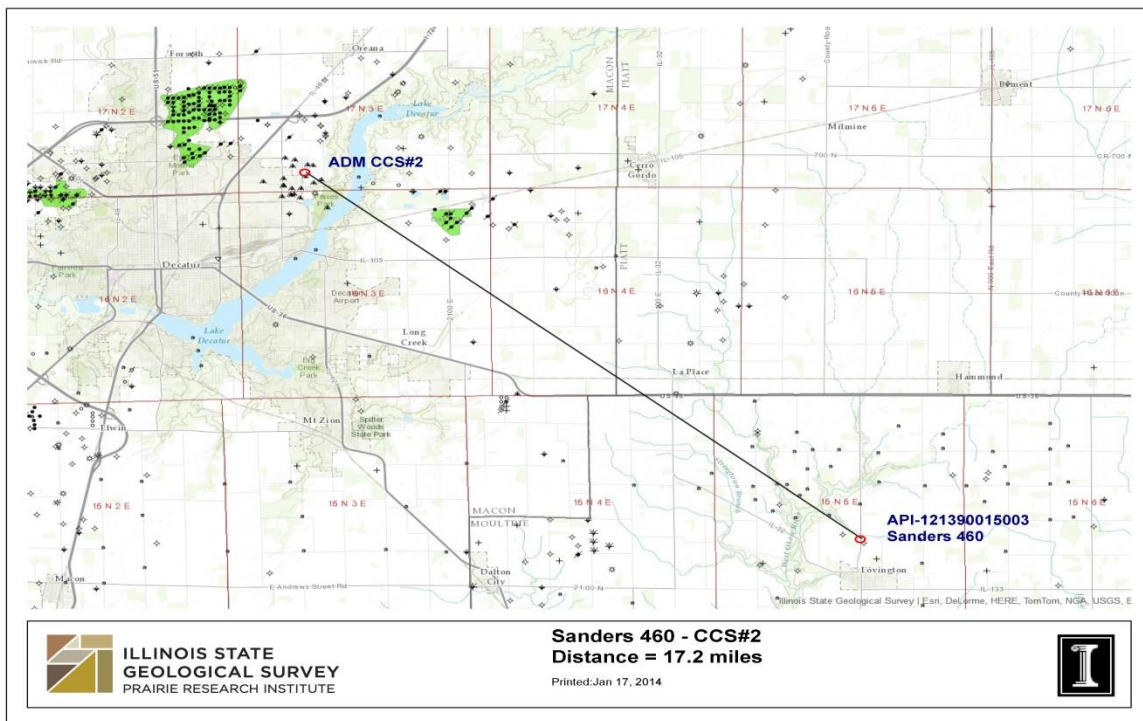

Figure 15. The closest penetration the seal formation (Eau Claire) is 17.2 miles from CCS#2. Based on a plume growth of 1.0% per year, it would take over 600 years for the project’s CO₂ plume to reach this well.

Evaluation of Passive Seismic Data

Finally, passive seismic monitoring will be used to help further demonstrate seal formation integrity. The operator will provide seismic monitoring data showing that no seismic events have occurred that would indicate fracturing or fault activation near or through the seal formation. This validation of seal integrity will provide further support for a demonstration that the CO₂ plume is no longer an endangerment to any USDWs. Figure 16 illustrates how these data could be presented. This figure shows a subset of locatable microseismic events occurring during part of the IBDP project’s operational period. From this figure one can see that a majority of the microseismic events occur in the lower Mt Simon and the Precambrian basement. No events are observed near the Eau Claire seal formation indicating that no fracturing or fault activation is occurring within this formation. This provides additional

verification of the Eau Claire formation's seal integrity and indicates that to date the response to the imposed fluid pressures due to injection are confined to the vicinity of the injection zone and below.

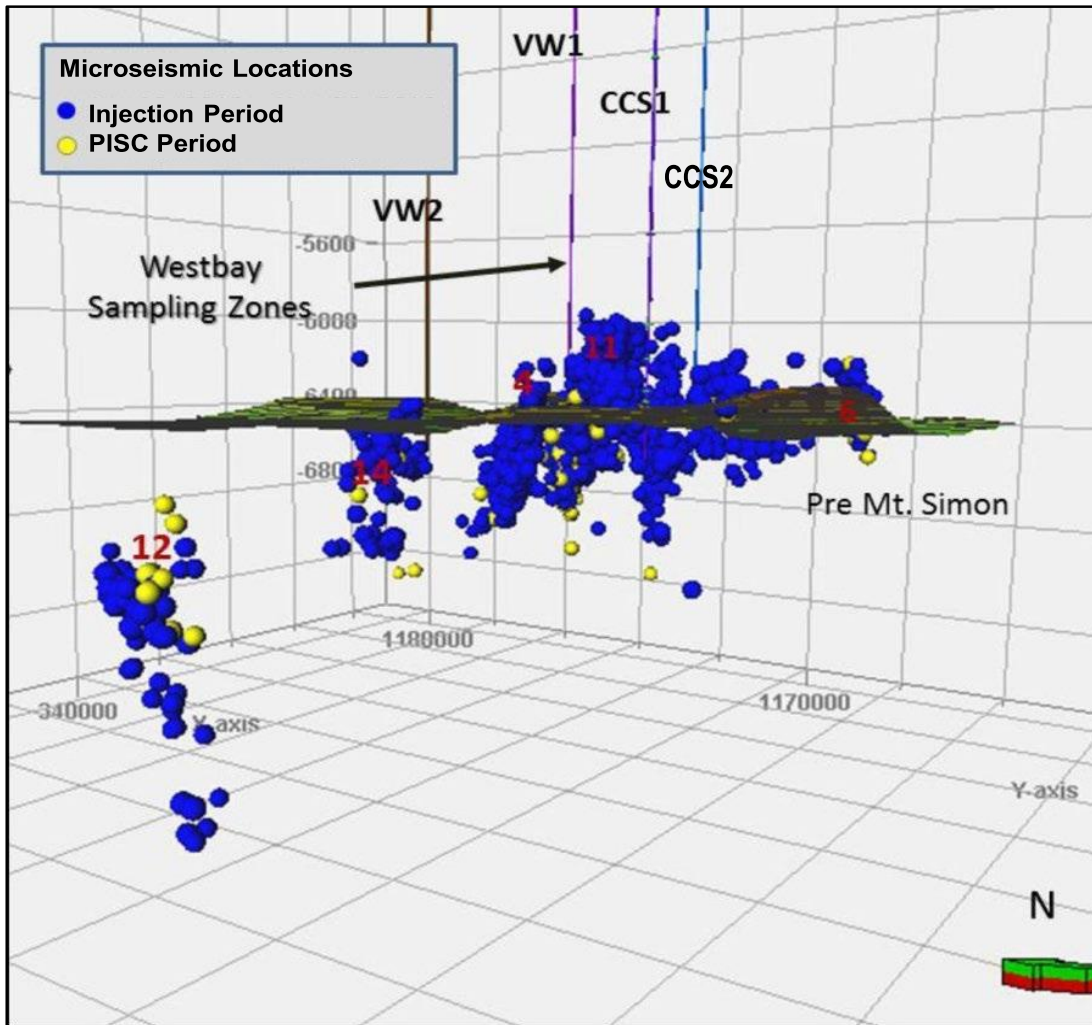

Figure 16. Visual representation showing the microseismic activity occurring during the injection and post injection periods. (Figure provided by IBDP project)

Site Closure Plan

ADM will conduct site closure activities to meet the requirements of 40 CFR 146.93(e) as described below. ADM will submit a final Site Closure Plan and notify the permitting agency at least 120 days prior of its intent to close the site. Once the permitting agency has approved closure of the site, ADM will plug the verification well(s) and geophysical well(s); restore the site and move out all equipment; and submit a site closure report to the Director. The activities, as described below, represent the planned activities based on information provided to EPA in November 2013. The actual site closure plan may employ different methods and procedures. A final Site Closure Plan will be submitted to the Director for approval with the notification of the intent to close the site.

Plugging the Verification Well(s)

The well will be flushed with a kill weight brine fluid. A minimum of three tubing volumes will be injected without exceeding fracture pressure. A final external MIT will be conducted to ensure mechanical integrity. Detailed plugging procedures are provided below. All casing in this well will be cemented to surface and will not be retrievable at abandonment. After injection ceases and after the appropriate post-injection monitoring period is finished, the completion equipment will be removed from the well.

Type and Quantity of Plugging Materials, Depth Intervals

Well cementing software (e.g., Schlumberger's CemCade) will be used to model the plugging and aid in the plug design. The cements used for plugging will be tested in the lab prior to plug placement and both wet and dry samples will be collected during plugging for each plug to ensure quality of the plug.

All of the casing strings will be cut off at least 3 feet below the surface, below the plow line. A blanking plate with the required permit information will be welded to the top of the cutoff casing.

Volume Calculations

Volumes will be calculated for the specific abandonment wellbore environment based on desired plug diameter and length required. The methodology employed will be to:

- 1) Choose the following:
 - a. Length of the cement plug desired.
 - b. Desired setting depth of base of plug.
 - c. Amount of spacer to be pumped ahead of the slurry.
- 2) Determine the following:
 - a. Number of sacks of cement required.
 - b. Volume of spacer to be pumped behind the slurry to balance the plug.
 - c. Plug length before the pipe is withdrawn.
 - d. Length of mud freefall in drill pipe.
 - e. Displacement volume required to spot the plug.

Plugging and Abandonment Procedure

At the end of the serviceable life of the verification well, the well will be plugged and abandoned. In summary, the plugging procedure will consist of removing all components of the completion system and then placing cement plugs along the entire length of the well. Prior to placing the cement plugs, casing inspection and temperature logs will be run confirming external mechanical integrity. If a loss of integrity is discovered then a plan to repair using the cement squeeze method will be prepared and submitted to the agency for review and approval. At the

surface, the well head will be removed; and the casing will be cut off 3 feet below surface. A detailed procedure follows:

1. Move in workover unit with pump and tank.
2. Record bottom hole pressure using down hole instrumentation and calculate kill fluid density. Pressure test annulus as per annual MIT requirements.
3. Fill both tubings with kill weight brine as calculated from Bottom hole pressure measurement (expected approximately 9.5 ppg).
4. Nipple down well head and nipple up BOPs.
5. Remove all completion equipment from well.
6. Keep hole full with workover brine of sufficient density to maintain well control.
7. Log well with CBL, temperature, mechanical inspection log to confirm external mechanical integrity.
8. Pick up work string (either 2 7/8" or 3 1/2") and trip in hole to PBTD.
9. Circulate hole two wellbore volumes to ensure that uniform density fluid is in the well.
10. The lower section of the well will be plugged using CO₂ resistant cement from TD around 7150ft to around 800ft above the top of the Eau Claire formation (to approximately 4200 ft). This will be accomplished by placing plugs in 500 foot increments. Using a density of 15.9 ppg slurry with a yield of 1.11 cf/sk, approximately 360 sacks of cement will be required (to incorporate a safety factor, 423 sacks are assumed: $3000 \text{ ft} \times .1305 \text{ cu ft/ft} \times 1.2 \text{ excess} / 1.11 \text{ cf/sk} = 423 \text{ sacks}$). Actual cement volume will depend upon actual weight of the casing within the plugged zone. This will require at least six plugs of 500 feet in length. No more than two plugs will be set before cement is allowed to set and plugs verified by setting work string weight down onto the plug.
11. Pull ten stands of tubing (600 ft) out and shut down overnight to wait on cement curing.
12. After appropriate waiting period, TIH ten stands and tag the plug. Resume plugging procedure as before and continue placing plugs until the last plug reaches the surface.
13. Nipple down BOPs.
14. Remove all well head components and cut off all casings below the plow line.
15. Finish filling well with cement from the surface if needed. Total of approximately 464 sacks total cement used in all remaining plugs above 4200 feet ($4200 \text{ ft} \times .1305 \text{ cu ft/ft} / 1.18 \text{ cu ft/sk} = 464 \text{ sks}$). Cement calculations based on using Class A cement from 4000 ft back to surface with a density of 15.6 ppg and a yield of 1.18 cu ft /sk. Lay down all work string, etc. Clean cellar to where a plate can be welded with well name onto lowest casing string at 3 feet, or as per permitting agency directive.
16. If required, install permanent marker back to surface on which all pertinent well information is inscribed.
17. Fill cellar with topsoil.

18. Rig down workover unit and move out all equipment. Haul off all workover fluids for proper disposal.
19. Reclaim surface to normal grade and reseed location.
20. Complete plugging forms and send in with charts and all lab information to the regulatory agency. Plugging report shall be certified as accurate by ADM and shall be submitted within 60 days after plugging is completed.

Note: 7,000 ft 5 ½” 17 #/ft (7000 ft X .1305 cu ft/ft = 914 cu ft) casing requires an estimated 914 cubic feet of cement to fill 14 plugs. An excess factor of 20% is being suggested on the lower 3000ft to accommodate cement that might be lost to the formation so total material used would be 423 sacks of EverCRETE CO₂ resistant cement and 442 sack Class A/H cement.

Approximately five days are required from move in to move out, depending on the operations at hand and the physical constraints of the well, weather, and other conditions.

See Figure 17 below for a plugging schematic.

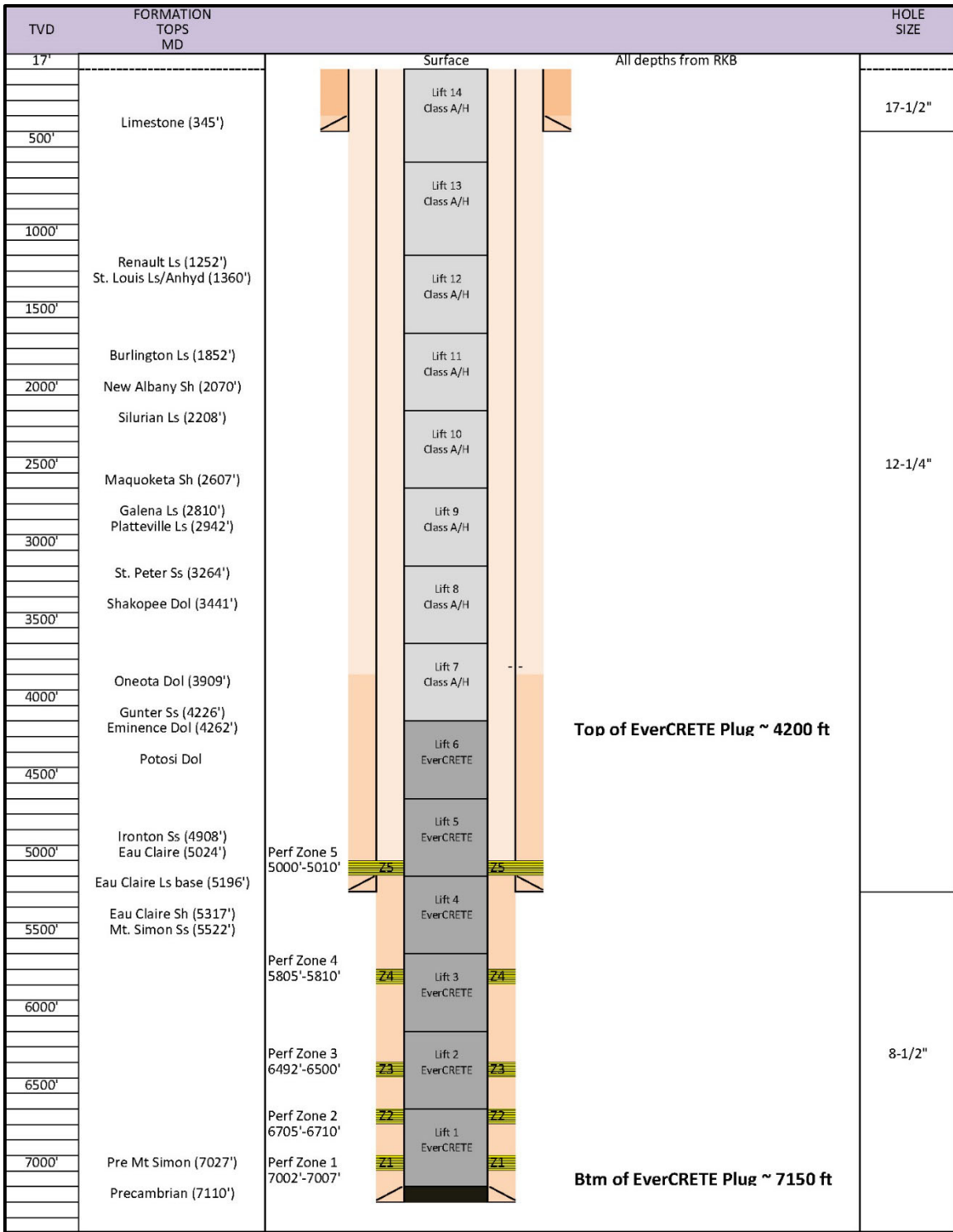

Figure 17. Representative Plugging Schematic - Verification Well.

Plugging the Geophysical Well(s)

At the end of the serviceable life of the well, the well will be plugged and abandoned utilizing the following procedure:

1. Notify the permitting agency of abandonment at least 60 days prior to plugging the well.
2. Remove any monitoring equipment from well bore. Well will contain fresh water or a mixture of fresh water and native St. Peter formation water.
3. Nipple down well head and connect cement pump truck to 4 ½ inch casing. Establish injection rate with fresh water. Mix and pump 247 sacks Class A cement (15.9 ppg). Slow injection rate to ½ bbl/min as cement starts to enter St. Peter perforations. Continue squeezing cement into formation until a squeeze pressure of 500 psi is obtained. Monitor static cement level in casing for 12 hours and fill with cement if needed to top out. Plan to have 50 sacks additional cement above calculated volume on location to top out if needed. (To incorporate a safety factor, 255 sacks are assumed: 3450 ft X .0873 cu ft/ft / 1.18 cu ft/sk = 255 sacks.)
4. After cement cures, cut off all well head components and cut off all casings below the plow line.
5. Install permanent marker at surface, or as required by the permitting agency.
6. Reclaim surface to normal grade and reseed location.

See Figure 18 below for a plugging schematic.

Geophysical Monitor #2 (St. Peter Monitoring & 3D VSP Well)

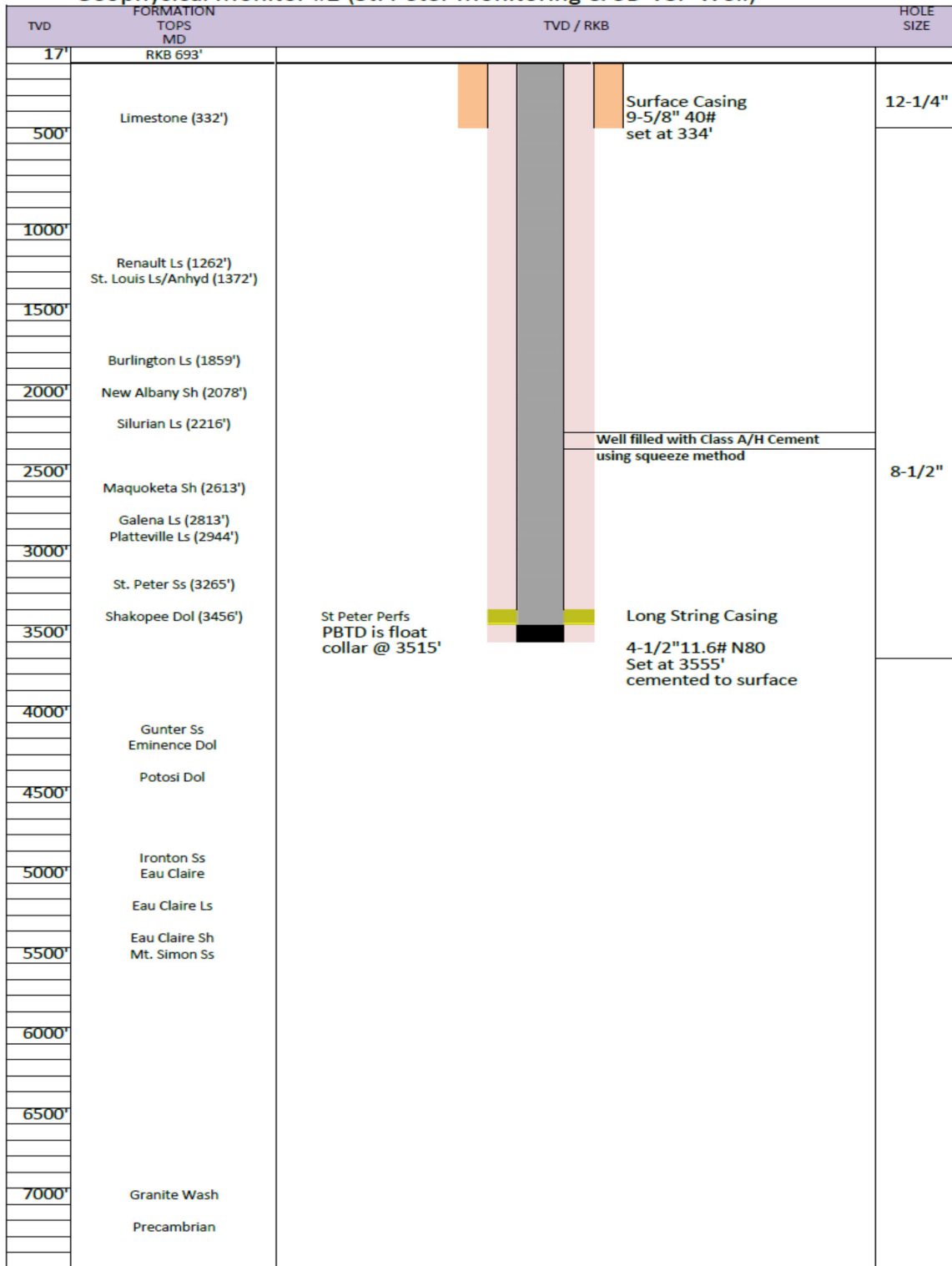

Figure 18. Representative Plugging schematic - geophysical well.

Planned Remedial/Site Restoration Activities

To restore the site to its pre-injection condition following site closure, ADM will be guided by the state rules for plugging and abandonment of wells located on leased property under The Illinois Oil and Gas Act: Title 62: Mining Chapter I: Department of Natural Resources - Part 240, Section 240.1170 - Plugging Fluid Waste Disposal and Well Site Restoration.

The following steps will be taken:

1. The free liquid fraction of the plugging fluid waste, which may consist of produced water and/or crude oil, shall be removed from the pit and disposed of in accordance with state and federal regulations (e.g., injection or in above ground tanks or containers pending disposal) prior to restoration. The remaining plugging fluid wastes shall be disposed of by on-site burial.
2. All plugging pits shall be filled and leveled in a manner that allows the site to be returned to original use with no subsidence or leakage of fluids, and where applicable, with sufficient compaction to support farm machinery.
3. All drilling and production equipment, machinery, and equipment debris shall be removed from the site.
4. Casing shall be cut off at least four (4) feet below the surface of the ground, and a steel plate welded on the casing or a mushroomed cap of cement approximately one (1) foot in thickness shall be placed over the casing so that the top of the cap is at least three (3) feet below ground level.
5. Any drilling rat holes shall be filled with cement to no lower than four (4) feet and no higher than three (3) feet below ground level.
6. The well site and all excavations, holes and pits shall be filled and the surface leveled.

Site Closure Report

A site closure report will be prepared and submitted within 90 days following site closure, documenting the following:

- Plugging of the verification and geophysical wells (and the injection well if it has not previously been plugged),
- Location of sealed injection well on a plat of survey that has been submitted to the local zoning authority,
- Notifications to state and local authorities as required at 40 CFR 146.93(f)(2),
- Records regarding the nature, composition, and volume of the injected CO₂, and
- Post-injection monitoring records.

ADM will record a notation to the property's deed on which the injection well was located that will indicate the following:

- That the property was used for carbon dioxide sequestration,

- The name of the local agency to which a plat of survey with injection well location was submitted,
- The volume of fluid injected,
- The formation into which the fluid was injected, and
- The period over which the injection occurred.

The site closure report will be submitted to the permitting agency and maintained by the operator for a period of 10 years following site closure. Additionally, the operator will maintain the records collected during the PISC period for a period of 10 years after which these records will be delivered to the Director.

Quality Assurance and Surveillance Plan (QASP)

The Quality Assurance and Surveillance Plan is presented in the Appendix of the Testing and Monitoring Plan.

ATTACHMENT F: EMERGENCY AND REMEDIAL RESPONSE PLAN

This plan is provided to meet the requirements of 40 CFR 146.94. As steps to prevent unexpected carbon dioxide (CO₂) movement have already been undertaken in accordance with risk analysis, this plan is about actions to be taken, and to be prepared to take, if unexpected fluid movement or any other emergency events occur.

Facility Name: Archer Daniels Midland, CCS#2 Well
IL-115-6A-0001

Facility Contacts: A site-specific list of facility contacts will be developed and maintained during the life of the project.

Injection Well Location: 39°53'09.32835", -88°53'16.68306"
Near the center of Section 32
Township 17N, Range 3E (Whitmore Township)
Decatur, Macon County, Illinois

This emergency and remedial response plan (ERRP) describes actions that the owner / operator (ADM) shall take to address movement of the injection fluid or formation fluid in a manner that may endanger an underground source of drinking water (USDW) during the operation or post-injection site care periods.

If ADM obtains evidence that the injected CO₂ stream and/or associated pressure front may cause an endangerment to a USDW, ADM must perform the following actions:

1. Initiate shutdown plan for the injection well.
2. Take all steps reasonably necessary to identify and characterize any release.
3. Notify the permitting agency (UIC Program Director) of the emergency event within 24 hours.
4. Implement applicable portions of the approved ERRP.

Where the phrase "initiate shutdown plan" is used, the following protocol will be employed: ADM will immediately cease injection. However, in some circumstances, ADM will, in consultation with the UIC Program Director, determine whether gradual cessation of injection (using the parameters set forth in Attachment A of the Class VI permit) is appropriate.

Part 1: Local Resources and Infrastructure

Resources in the vicinity of the IL-ICCS project that may be impacted as a result of an emergency event at the project site include: underground sources of drinking water (USDWs); potable water wells; the Sangamon River; Bois Du Sangamon Nature Preserve; and Lake Decatur.

Infrastructure in the vicinity of the IL-ICCS project that may be impacted as a result of an emergency at the project site include: the wellhead; Richland Community College structures; and ADM facilities. A map of the local area is provided as Figure F-2 at the end of this plan.

Part 2: Potential Risk Scenarios

The following events related to the IL-ICCS project could potentially result in an emergency response:

- Injection or monitoring (verification) well integrity failure;
- Injection well monitoring equipment failure (e.g., shut-off valve or pressure gauge, etc.);
- A natural disaster (e.g., earthquake, tornado, lightning strike);
- Fluid (e.g. brine) leakage to a USDW;
- CO₂ leakage to USDW or land surface; or
- Induced seismic event.

Response actions will depend on the severity of the event(s) triggering an emergency response. “Emergency events” are categorized as follows:

| TABLE F-1. DEGREES OF RISK FOR EMERGENCY EVENTS | |
|--|---|
| Emergency Condition | Definition |
| Major Emergency | Event poses immediate substantial risk to human health, resources, or infrastructure. Emergency actions involving local authorities (evacuation or isolation of areas) should be initiated. |
| Serious Emergency | Event poses potential serious (or significant) near term risk to human health, resources, or infrastructure if conditions worsen or no response actions taken. |
| Minor Emergency | Event poses no immediate risk to human health, resources, or infrastructure. |

In the event of an emergency requiring cessation of injection, CO₂ slated for injection may be released to the atmosphere.

Part 3: Emergency Identification and Response Actions

Steps to identify and characterize the event will be dependent on the specific issue identified, and the severity of the event. The potential risk scenarios identified in Part 2 are detailed below.

In the event of an emergency requiring outside assistance, the lead project contact shall call the ADM Security Dispatch at (217) 424-4444 and ADM Corporate Communications at (217) 424-5413.

Well Integrity Failure.

Integrity loss of the injection well and/or verification well may endanger USDWs. Integrity loss may have occurred if the following events occur:

- a. Automatic shutdown devices are activated.
 - Wellhead pressure exceeds the specified shutdown pressure specified in the permit;
 - Annulus pressure indicates a loss of external or internal well containment;

ADM is required to notify the UIC Program Director within 24 hours (40 CFR 146.91(c)(3) of any triggering of a shut-off system (i.e., down-hole or at the service).

- b. Mechanical integrity test results identify a loss of mechanical integrity.

Response Actions:

- Immediately notify the ADM plant superintendent or designee.
- Notify the UIC Program Director within 24 hours of the emergency event, per 40 CFR 146.91(c).
- The plant superintendent will make an initial assessment of the situation and determine which other project personnel to notify.
- Project contacts will determine the severity of the event, based on the information available, within 24 hours of notification.
- For a Major or Serious Emergency:
 - Initiate shutdown plan.
 - Shut in well (close flow valve).
 - Vent CO₂ from surface facilities.
 - Limit access to wellhead to authorized personnel only.
 - Communicate with ADM personnel and local authorities to initiate evacuation plans, as necessary.
 - Monitor well pressure, temperature, and annulus pressure to verify integrity loss and determine the cause and extent of failure; identify and implement appropriate remedial actions to repair damage to the well (in consultation with the UIC Program Director).
 - If contamination is detected, identify and implement appropriate remedial actions (in consultation with the UIC Program Director).
- For a Minor Emergency:
 - Conduct assessment to determine whether there has been a loss of mechanical integrity.
 - If there has been a loss of mechanical integrity, initiate shutdown plan.
 - Shut in well (close flow valve).
 - Vent CO₂ from surface facilities.
 - Reset automatic shutdown devices.
 - Monitor well pressure, temperature, and annulus pressure to verify integrity loss and determine the cause and extent of failure; identify and, if necessary, implement appropriate remedial actions (in consultation with the UIC Program Director).

Injection Well Monitoring Equipment Failure.

The failure of monitoring equipment for wellhead pressure, temperature, and/or annulus pressure may indicate a problem with the injection well that could endanger USDWs.

Response Actions:

- Immediately notify the ADM plant superintendent or designee.
- Notify the UIC Program Director within 24 hours of the emergency event, per 40 CFR 146.91(c).
- The plant superintendent will make an initial assessment of the situation and determine which other project personnel to notify.
- Project contacts will determine the severity of the event, based on the information available, within 24 hours of notification.
- For a Major or Serious Emergency:
 - Initiate shutdown plan.
 - Shut in well (close flow valve).
 - Vent CO₂ from surface facilities.
 - Limit access to wellhead to authorized personnel only.
 - Communicate with ADM personnel and local authorities to initiate evacuation plans, as necessary.
 - Monitor well pressure, temperature, and annulus pressure (manually if necessary) to determine the cause and extent of failure.
 - Identify and, if necessary, implement appropriate remedial actions (in consultation with the UIC Program Director).
- For a Minor Emergency:
 - Conduct assessment to determine whether there has been a loss of mechanical integrity.
 - If there has been a loss of mechanical integrity, initiate shutdown plan.
 - Shut in well (close flow valve).
 - Vent CO₂ from surface facilities.
 - Reset or repair automatic shutdown devices.
 - Monitor well pressure, temperature, and annulus pressure (manually if necessary) to determine the cause and extent of failure.
 - Identify and, if necessary, implement appropriate remedial actions (in consultation with the UIC Program Director).

Potential Brine or CO₂ Leakage to USDW. Elevated concentrations of indicator parameter(s) in groundwater sample(s) or other evidence of fluid (brine) or CO₂ leakage into a USDW.

Response Actions:

- Immediately notify the ADM plant superintendent or designee.
- Notify the UIC Program Director within 24 hours of the emergency event, per 40 CFR 146.91(c).
- The plant superintendent will make an initial assessment of the situation and determine which other project personnel to notify.
- Project contacts will determine the severity of the event, based on the information available, within 24 hours of notification.
- For all Emergencies (Major, Serious, or Minor):
 - Initiate shutdown plan.
 - Shut in well (close flow valve).
 - Vent CO₂ from surface facilities.
 - Collect a confirmation sample(s) of groundwater and analyze for indicator parameters. (Potential indicators are listed in Tables 7 and 11 of Attachment C, the Testing and Monitoring Plan.)
 - If the presence of indicator parameters is confirmed, develop (in consultation with the UIC Program Director) a case-specific work plan to:
 - Install additional groundwater monitoring points near the impacted groundwater well(s) to delineate the extent of impact; and
 - Remediate unacceptable impacts to the impacted USDW.
 - Arrange for an alternate potable water supply, if the USDW was being utilized and has been caused to exceed drinking water standards.
 - Proceed with efforts to remediate USDW to mitigate any unsafe conditions (e.g., install system to intercept/extract brine or CO₂ or “pump and treat” to aerate CO₂-laden water).
 - Continue groundwater remediation and monitoring on a frequent basis (frequency to be determined by ADM and the UIC Program Director) until unacceptable adverse USDW impact has been fully addressed.

Natural Disaster. Well problems (integrity loss, leakage, or malfunction) may arise as a result of a natural disaster impacting the normal operation of the injection well. An earthquake may disturb surface and/or subsurface facilities; and weather-related disasters (e.g., tornado or lightning strike) may impact surface facilities.

If a natural disaster occurs that affects normal operation of the injection well, perform the following:

Response Actions:

- Immediately notify the ADM plant superintendent or designee.
- Notify the UIC Program Director within 24 hours of the emergency event, per 40 CFR 146.91(c). The plant superintendent will make an initial assessment of the situation and determine which other project personnel to notify.
- Project contacts will determine the severity of the event, based on the information available, within 24 hours of notification.
- For a Major or Serious Emergency:
 - Initiate shutdown plan.
 - Shut in well (close flow valve).
 - Vent CO₂ from surface facilities.
 - Limit access to wellhead to authorized personnel only.
 - Communicate with ADM personnel and local authorities to initiate evacuation plans, as necessary.
 - Monitor well pressure, temperature, and annulus pressure to verify well status and determine the cause and extent of any failure.
 - Determine if any leaks to ground water or surface water occurred.
 - If contamination or endangerment is detected, identify and implement appropriate remedial actions (in consultation with the UIC Program Director).
- For a Minor Emergency:
 - Conduct assessment to determine whether there has been a loss of mechanical integrity.
 - If there has been a loss of mechanical integrity, initiate shutdown plan.
 - Shut in well (close flow valve).
 - Vent CO₂ from surface facilities.
 - Limit access to wellhead to authorized personnel only.
 - Monitor well pressure, temperature, and annulus pressure to verify integrity loss and determine the cause and extent of any failure.
 - Identify and, if necessary, implement appropriate remedial actions (in consultation with the UIC Program Director).

Induced Seismic Event. Induced seismic events typically refer to minor seismic events that are caused by human activity which alters the stresses and fluid pressures in the earth's crust. Induced seismicity could potentially result from the injection of fluids into subsurface formations that lubricate and or change the stress state of pre-existing faults which causes fault plane movement and energy release. Most induced seismic events are extremely small (microseismic) but in some instances are great enough to be felt by humans. Case histories of induced seismic events associated with fluid disposal wells show seismic events as far away as about 10 to 12 km (6.2 to 7.4 miles). Based on the project operating conditions, it is highly unlikely that injection operations would ever induce a seismic event outside an eight (8) mile radius from the wellhead. Therefore this portion of the response plan is developed for any seismic event with an epicenter within a eight (8) mile radius of the injection well.

To monitor the area for seismicity, the site has installed five (5) surface seismic monitoring stations and three (3) borehole monitoring stations that continuously record the site's seismic activity. In addition to these stations, the USGS has deployed a network of nine (9) surface seismic monitoring stations and three (3) borehole monitoring stations. Based on the periodic analysis of the monitoring data, observed level of seismic activity, and local reporting of felt events, the site will be assigned an operating state. The operating state is determined using threshold criteria which correspond to the site's potential risk and level of seismic activity. The operating state provides operating personnel information about the potential risk of further seismic activity and guides them through a series of response actions. In the following table the ADM Decatur Seismic Monitoring System is presented. The table corresponds each level of operating state with the threshold conditions and operational response actions.

Table F-2a. ADM Decatur Seismic Monitoring System ⁽¹⁾

| Operating State | Threshold Condition | Response Action |
|-----------------|--|---|
| Green | Seismic events less than or equal to M1.5 ⁽²⁾ | 1. Continue normal operation within permitted levels. |
| Yellow | Five (5) or more seismic events within a 30 day period having a magnitude greater than M1.5 ⁽²⁾ but less than or equal to M2.0 ⁽²⁾ . | 1. Continue normal operation within permitted levels. 2. Within 24 hours of the incident, notify the UIC Program Director and ISGS of the operating status of the well. |
| Orange | Seismic event greater than M1.5 ⁽²⁾ ; and Local observation or felt report ⁽³⁾ . | 1. Continue normal operation within permitted levels. 2. Within 24 hours of the incident, notify the UIC Program Director, ISGS, and ADM Communications of the operating status of the well. |
| | Seismic event greater than M2.0 ⁽²⁾ and no felt report | 3. Review seismic and operational data. 4. Report findings to the UIC Program Director and issue corrective actions ⁽⁵⁾ . |

1. Seismic events < M1.0 with an epicenter within an 8 mile radius of the injection well.
2. Determined by the local ADM or USGS seismic monitoring stations or reported by the USGS National Earthquake Information Center using the national seismic network.
3. Confirmed by local reports of felt ground motion or reported on the USGS “Did You Feel It?” reporting system.
4. Onset of damage is defined as cosmetic damage to structures – such as bricks dislodged from chimneys and parapet walls, broken windows, and fallen objects from walls, shelves, and cabinets.
5. Within 25 business days (five weeks) of change in operating state.

Table F-2b. ADM Decatur Seismic Monitoring System ⁽¹⁾

| Operating State | Threshold Condition | Response Action |
|---|--|---|
| <p style="text-align: center; color: magenta; font-weight: bold;">Magenta</p> | <p style="text-align: center;">Seismic event greater than M2.0 ⁽²⁾; and Local observation or report ⁽³⁾.</p> | <ol style="list-style-type: none"> 1. Initiate rate reduction plan. 2. Vent CO₂ from surface facilities. 3. Within 24 hours of the incident, notify the UIC Program Director, ISGS, and ADM Communications of the operating status of the well. 4. Limit access to wellhead to authorized personnel only. 5. Communicate with ADM personnel and local authorities to initiate evacuation plans, as necessary. 6. Monitor well pressure, temperature, and annulus pressure to verify well status and determine the cause and extent of any failure; identify and implement appropriate remedial actions (in consultation with the UIC Program Director). 7. Determine if leaks to ground water or surface water occurred. 8. If USDW contamination is detected, <ol style="list-style-type: none"> a. Notify the UIC Program Director within 24 hours of the determination. b. Initiate shutdown plan. c. Shut in well (close flow valve). d. Vent CO₂ from surface facilities. e. Identify and implement appropriate remedial actions (in consultation with the UIC Program Director). 9. Review seismic and operational data. 10. Report findings to the UIC Program Director and issue corrective actions ⁽⁵⁾. |

1. Seismic events < M1.0 with an epicenter within an 8 mile radius of the injection well.
2. Determined by the local ADM or USGS seismic monitoring stations or reported by the USGS National Earthquake Information Center using the national seismic network.
3. Confirmed by local reports of felt ground motion or reported on the USGS “Did You Feel It?” reporting system.
4. Onset of damage is defined as cosmetic damage to structures – such as bricks dislodged from chimneys and parapet walls, broken windows, and fallen objects from walls, shelves, and cabinets.
5. Within 25 business days (five weeks) of change in operating state.

Table F-2c. ADM Decatur Seismic Monitoring System ⁽¹⁾

| Operating State | Threshold Condition | Response Action |
|---|--|--|
| <p style="text-align: center;">Red</p> | <p>Seismic event greater than M2.0 ⁽²⁾; Local observation or report ⁽³⁾; and Local report and confirmation of damage ⁽⁴⁾.</p> | <ol style="list-style-type: none"> 1. Initiate shutdown plan. 2. Shut in well (close flow valve). Vent CO₂ from surface facilities. 3. Within 24 hours of the incident, notify the UIC Program Director, ISGS, and ADM Communications of the operating status of the well. 4. Limit access to wellhead to authorized personnel only. 5. Communicate with ADM personnel and local authorities to initiate evacuation plans, as necessary. 6. Monitor well pressure, temperature, and annulus pressure to verify well status and determine the cause and extent of any failure; identify and implement appropriate remedial actions (in consultation with the UIC Program Director). 7. Determine if leaks to ground water or surface water occurred. 8. If USDW contamination is detected, <ol style="list-style-type: none"> a. Notify the UIC Program Director within 24 hours of the determination. b. Identify and implement appropriate remedial actions (in consultation with the UIC Program Director). 9. Review seismic and operational data. 10. Report findings to the UIC Program Director and issue corrective actions ⁽⁵⁾. |
| | <p>Seismic event >M3.5 ⁽²⁾</p> | |

1. Seismic events < M1.0 with an epicenter within an 8 mile radius of the injection well.
2. Determined by the local ADM or USGS seismic monitoring stations or reported by the USGS National Earthquake Information Center using the national seismic network.
3. Confirmed by local reports of felt ground motion or reported on the USGS “Did You Feel It?” reporting system.
4. Onset of damage is defined as cosmetic damage to structures – such as bricks dislodged from chimneys and parapet walls, broken windows, and fallen objects from walls, shelves, and cabinets.
5. Within 25 business days (five weeks) of change in operating state.

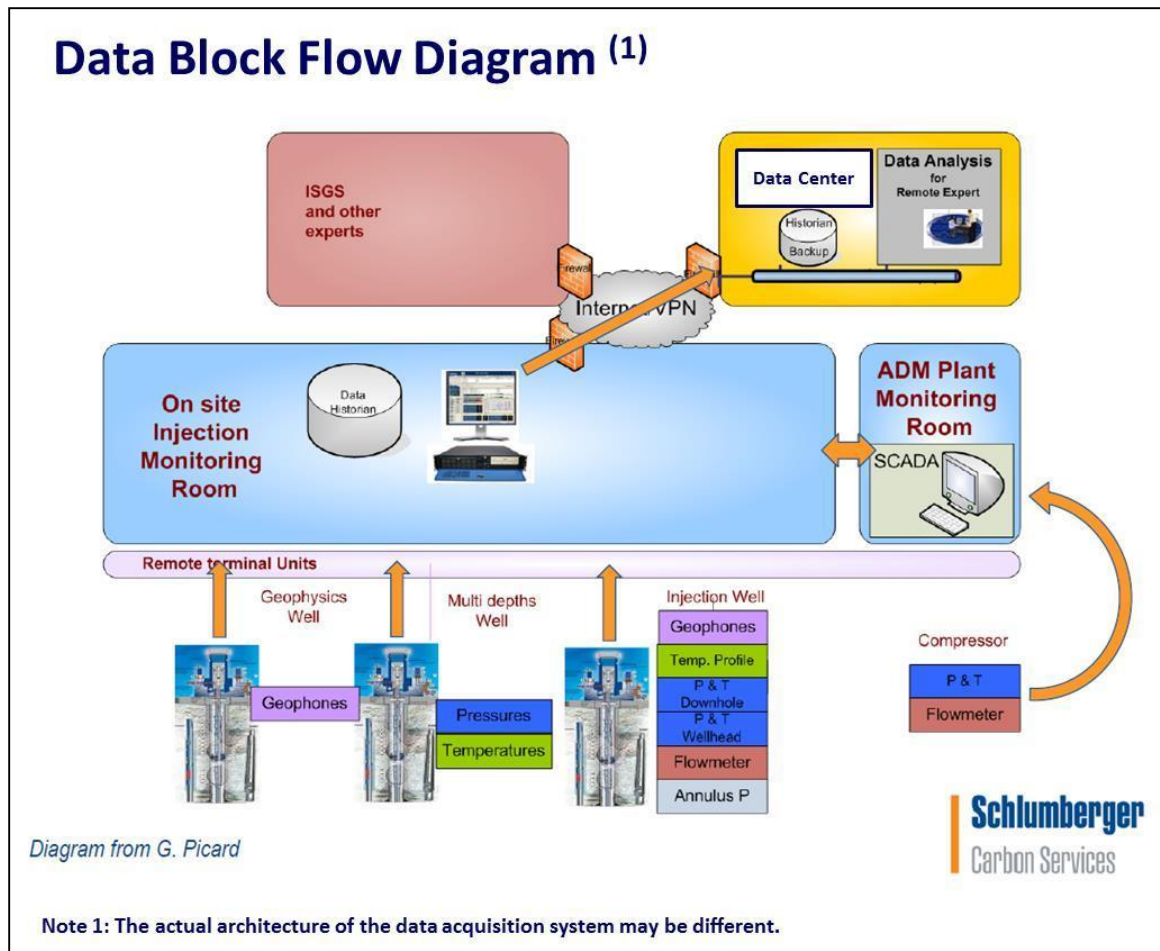

Figure F-1. The process by which seismic data are acquired, transmitted, processed, and evaluated by ADM to support the process.

1. Seismic data is recorded in real time from all stations.
2. Data from specific borehole and surface stations is transferred to a central data acquisition system where it is processed to determine the magnitude of the seismic event.
3. An email alert notification is sent out for events with magnitudes greater than M1.0.
4. If the seismic activity results in the site's operational state escalating above yellow, additional data from remote seismic stations will be retrieved.
5. The seismic data will undergo additional processing to refine the magnitude and determine location of the event(s).
6. The data will be evaluated by subject matter experts and a report of findings and recommendations will be issued within 25 business days.

Part 4: Response Personnel and Equipment

Site personnel, project personnel, and local authorities will be relied upon to implement this ERRP. The injection well and areas to the west and southwest are located within the limits of the City of Decatur; however, adjacent areas to the southeast, east, and north are outside of city limits. Therefore, both city and county emergency responders (as well as state agencies) may need to be notified in the event of an emergency.

Site personnel to be notified (not listed in order of notification):

1. *ADM Project Engineer(s)*
2. *ADM Plant Safety Manager(s)*
3. *ADM Environmental Manager(s)*
4. *ADM Plant Manager*
5. *ADM Plant Superintendent*
6. *ADM Corporate Communications*

A site-specific emergency contact list will be developed and maintained during the life of the project. ADM will provide the current site-specific emergency contact list to the UIC Program Director.

Local Authorities (including but not limited to):

| Agency: | Phone No. |
|--|------------------------------------|
| City of Decatur Police Department | 217-424-2711 |
| City of Decatur Fire Department | 217-424-2811 |
| Macon County Sheriff | 217-424-1311 |
| Illinois State Police | 217-786-7107 |
| Illinois Emergency Management Agency | 800-782-7860 |
| Macon County Emergency Management Agency | 217-424-1327 |
| Bodine Environmental Services | 800-637-2379 |
| UIC Program Director (US EPA Region V) | 312-353-7648 |
| US EPA National Response Center (24 hr) | 800-424-8802 |
| Illinois State Geological Survey | 217-244-8389, 4068 217-649-1744 |

Equipment needed in the event of an emergency and remedial response will vary, depending on the triggering emergency event. Response actions (cessation of injection, well shut-in, and evacuation) will generally not require specialized equipment to implement. Where specialized equipment (such as a drilling rig or logging equipment) is required, the designated Subcontractor Project Manager shall be responsible for its procurement.

Part 5: Emergency Communications Plan

ADM will communicate to the public about any event that requires an emergency response, in consultation with the UIC Program Director.

In the event of an emergency requiring outside assistance, the project contact lead shall call the ADM Security Dispatch at (217) 424-4444 and ADM Corporate Communications at (217) 424-5413.

- Emergency communications with the public will be handled by ADM Corporate Communications.
- ADM Corporate Communications, in consultation with the UIC Program Director, will determine the method, frequency, and extent of public communication based upon the emergency event's severity and impact to the public.
- ADM will describe what happened, any impacts to the environment or other local resources, how the event was investigated, what responses were taken, and the status of the response (including any updates, as necessary).
- ADM Corporate Communications will manage all ADM media communications with the public (through either interview, press release, Web posting, or other) in the event of an emergency situation related to the injection project.
- The individual to be designated by ADM will be the first contact during an emergency event.
- This individual will contact the crisis communication team as appropriate. Emergency responses to the media from ADM will be dealt with ONLY by the personnel so designated by ADM.
- Those individuals should try to be reachable 24 hours a day for contact in the event of an emergency.

In the event that anyone else at ADM is contacted to comment on any situation deemed an "emergency event," the media contact should be directed to ADM's 24/7 media line at 217-424-5413 or Media@adm.com.

Part 6: Plan Review

This ERRP shall be reviewed:

- at least once every five (5) years following its approval by the permitting agency,
- within one (1) year of an area of review (AoR) re-evaluation,
- within a prescribed period (to be determined by the permitting agency) following any significant changes to the injection process, the injection facility or an emergency event, or
- as required by the permitting agency.

If the review indicates that no amendments to the ERRP are necessary, provide the permitting agency with the documentation supporting the “no amendment necessary” determination.

If the review indicates that amendments to the ERRP are necessary, amendments shall be made and submitted to the permitting agency within six (6) months following an event that initiates the ERRP review procedure.

Part 7: Staff Training and Exercise Procedures

ADM will integrate the ERRP into the plant specific standard operating procedures and training program as described in the SOP entitled 180.60.ENV.130 “*Environmental Training, Awareness and Competence.*” Periodic training will be provided, not less than annually, to well operators, plant safety and environmental personnel, the plant manager, plant superintendent, and corporate communications. The training plan will document that the above listed personnel have been trained and possess the required skills to perform their relevant emergency response activities described in the ERRP.

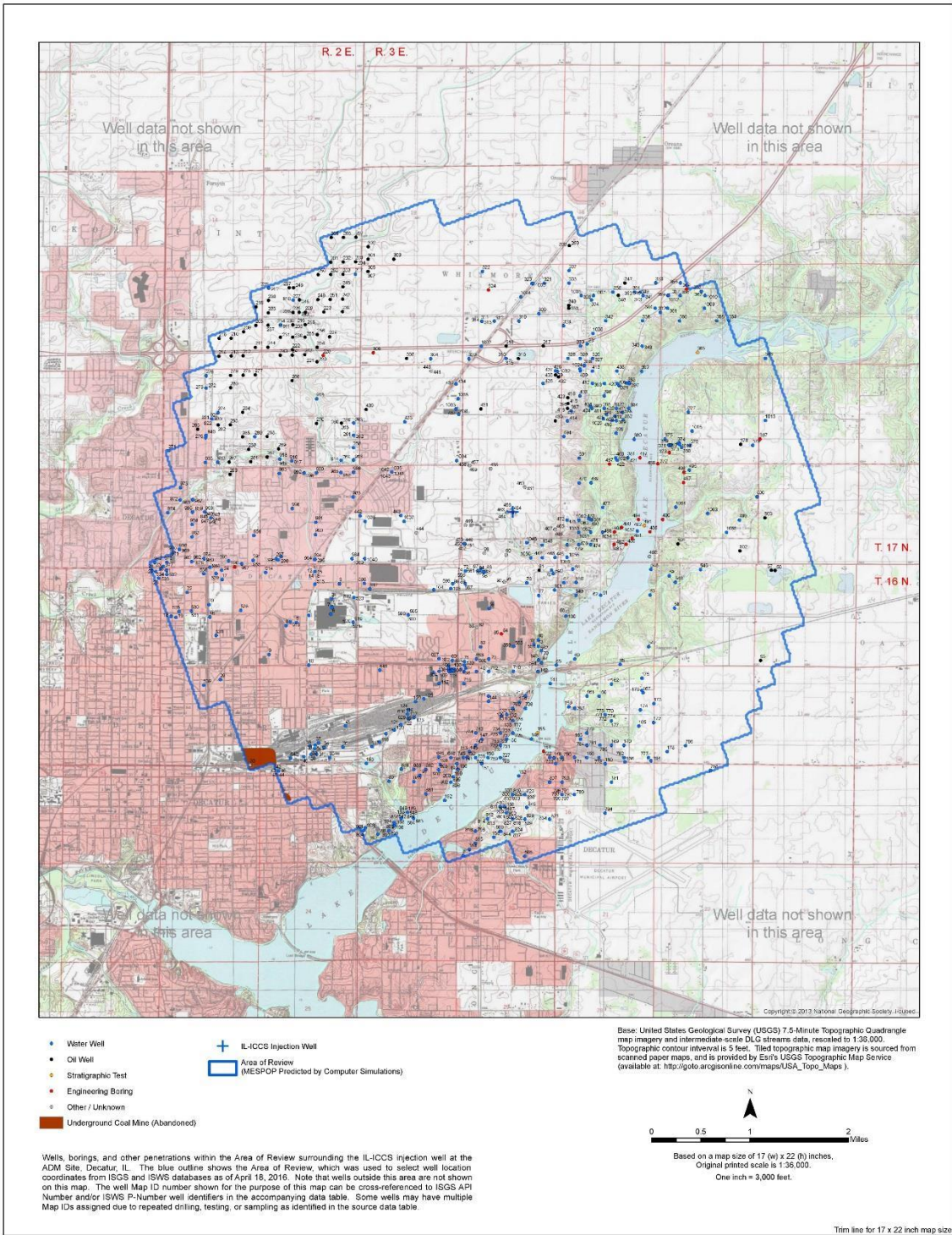

Figure F-2. Local area map for the IL-ICCS project. Emergency & remedial response activities will most likely be within the “area of review” highlighted on the map. Source: ISGS and ISWS well databases, current as of September May 10, 20161.

ATTACHMENT G: CONSTRUCTION DETAILS

Facility name: Archer Daniels Midland, CCS#2 Well
 IL-115-6A-0001
 4666 Faries Parkway, Decatur, IL

Well location: Decatur, Macon County, IL;
 39° 53' 09.32835", -88° 53' 16.68306"

Open hole diameters and intervals

| Name | Depth Interval (feet) | Open Hole Diameter (inches) | Comment |
|--------------|-----------------------|-----------------------------|-----------------|
| Surface | 0 - 347 | 26 | To bedrock |
| Intermediate | 347- 5,234 | 17 ½ | To primary seal |
| Long | 5,234 - 7,190 | 12 ¼ | To Total Depth |

Casing Specifications

| Name | Depth Interval (feet) | Outside Diameter (inches) | Inside Diameter (inches) | Weight (lb/ft) | Grade (API) | Design Coupling (Short or Long Threaded) | Thermal Conductivity @ 77 ° F (BTU/ft.hr.°F) |
|----------------------------|-----------------------|---------------------------|--------------------------|----------------|-------------|--|--|
| Surface ¹ | 0 -347 | 20 | 19.124 | 94 | J55 | Short | 31 |
| Intermediate ² | 0 -5,234 | 13 3/8 | 12.515 | 61 | J55 | Long or Buttress | 31 |
| Long ³ (carbon) | 0 - 4,818 | 9 5/8 | 8.835 | 40.0 | L80-HC | Long or Buttress | 31 |
| Long ³ (chrome) | 4,818 - 7,190 | 9 5/8 | 8.681 | 47.0 | 13CR80 | Special | 16 |

Note 1: Surface casing is 347 ft of 20 inch casing. After drilling a 26" hole to 347' true vertical depth (TVD), 20", 94 ppf, J55, short thread and coupling (STC) casing was set and cemented to surface. Coupling outside diameter is ~21 inches.

Note 2: Intermediate casing: 5,234 ft of 13 3/8 inch casing. After a shoe test or formation integrity test (FIT) was performed, a 17 1/2" hole was drilled to 5,234' TVD. 13-3/8", 61 ppf, J55, long thread and coupling (LTC) or buttress thread and coupling (BTC) was cemented to surface. Coupling outside diameter is ~14 3/8 inches.

Note 3: Long string casing: 0-4,818 ft of 9 5/8 inch, L80-HC casing; 4,818' – 7,190' of 9 5/8 inch, 13CR80. After a shoe test was performed and the integrity of the casing was tested, a 12 ¼" hole was drilled to 7190' TVD or through the Mt. Simon, where the long string casing was run and specially cemented. Coupling outside diameter is 10 5/8 inches for L80-HC and 10.485 inches for the 13CR80.

Tubing Specifications

| Name | Depth Interval (feet) | Outside Diameter (inches) | Inside Diameter (inches) | Weight (lb/ft) | Grade (API) | Design Coupling (Short or Long Thread) | Burst strength (psi) | Collapse strength (psi) |
|-----------------------------------|-----------------------|---------------------------|--------------------------|----------------|-------------|--|----------------------|-------------------------|
| Injection tubing ^{1,2,3} | 0-6,350 | 5 ½ | 3.963 | 17 | 13CR80 | Special | 8,960 | 7,820 |

Note 1: Maximum allowable suspended weight based on joint strength of injection tubing. Specified yield strength (weakest point) on tubular and connection is 306,000 lbs.

Note 2: Weight of injection tubing string (axial load) in air (dead weight) is 88,200 lbs.

Note 3: Thermal conductivity of tubing @ 77°F is 16 BTU / ft.hr.°F.

The injection well has approximately 80 feet of cement above the casing shoe to prevent the injection fluid from coming in contact with the Precambrian granite basement. The figure on the following page is the “as built” well construction schematic for CCS#2.

IL-ICCS CCS #2 Well Schematic

Depths are reference to Kelly Bushing = 691.2 ft. above MSL
 KB = 15.5 ft. above ground, site elevation = 675.7 ft. above MSL

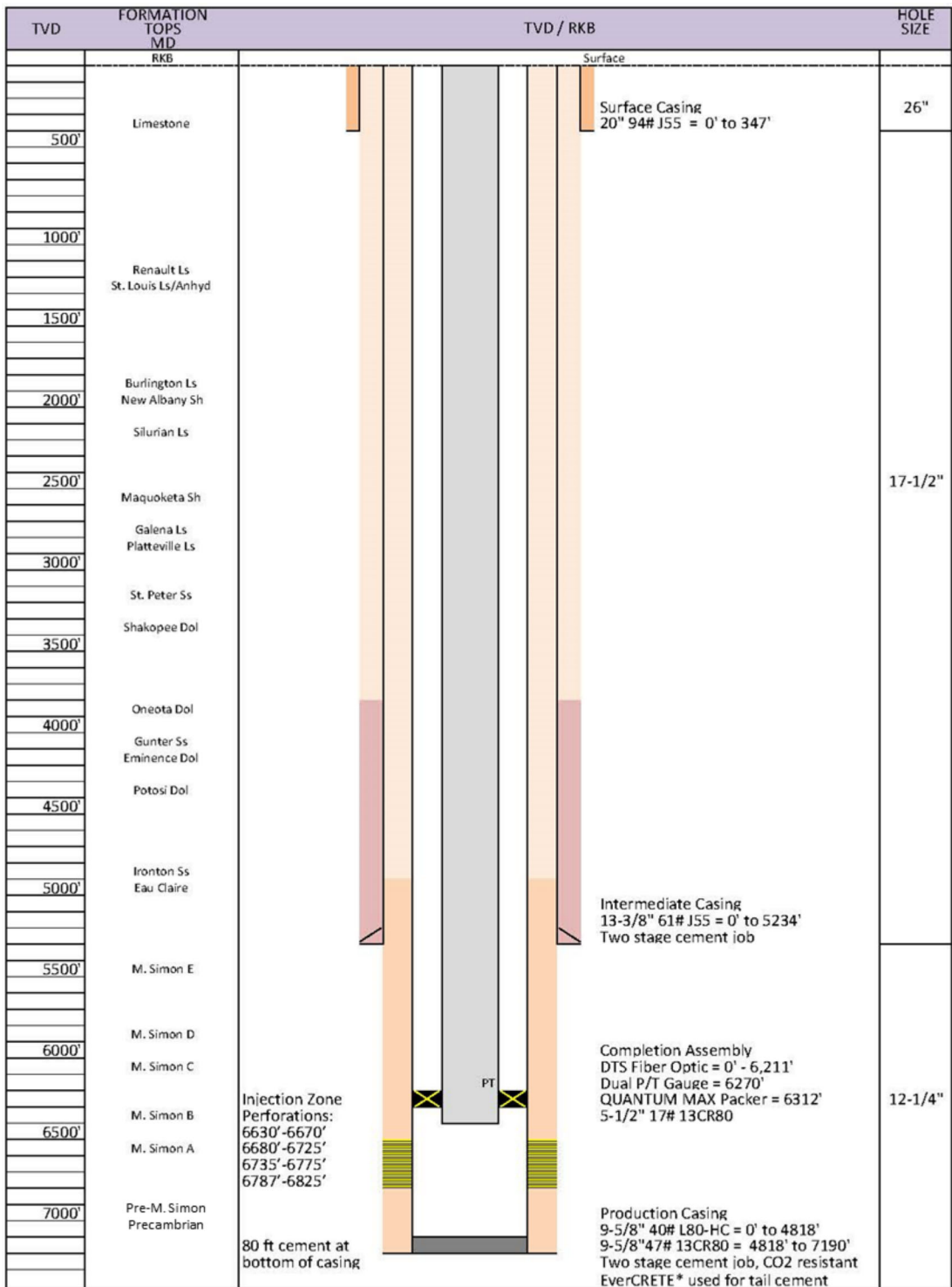

ATTACHMENT H: FINANCIAL ASSURANCE DEMONSTRATION

Facility name: Archer Daniels Midland, CCS#2 Well
IL-115-6A-0001
4666 Faries Parkway, Decatur, IL

Well location: Decatur, Macon County, IL;
39°53'09.32835", -88°53'16.68306"

ADM is providing financial responsibility pursuant to 40 CFR 146.85. ADM is using a corporate guarantee to cover the costs of: corrective action, emergency and remedial response, injection well plugging, and post-injection site care and site closure.

The updated costs of each of these activities submitted pursuant to 40 CFR 146.82(c) on October 25, 2016 are presented in Table 1:

Table 1. Cost Estimates for Activities to be Covered by Financial Responsibility

| Activity | Total Cost (in Millions of \$) |
|--|---|
| Performing Corrective Action on Wells in AoR | \$0.25 |
| Plugging Injection Wells | \$0.65 |
| Post-Injection Site Care | \$7.80 |
| Site Closure | \$0.59 |
| Emergency and Remedial Response | \$33.81 |

Attachment 1: CFO Letter



Archer Daniels Midland Company
 Global Headquarters
 77 W. Wacker Drive, Suite 4600
 Chicago, Illinois 60601
 t (312) 634.8100 / f (312) 634.8105

ADM.COM

March 11, 2016

Via Electronic Submittal

Tinka Hyde, Director, Water Division
 US Environmental Protection Agency
 Region 5
 77 West Jackson Boulevard
 Chicago, IL 60604-3590

Dear Director Hyde:

I am the chief financial officer of Archer Daniels Midland Company, headquartered at 77 W. Wacker Drive, Suite 4600, Chicago, IL 60601. This letter is in support of this firm's use of the financial test to demonstrate financial assurance.

This firm is the owner or operator of the following injection wells for which financial assurance for the current corrective action, injection well plugging, post injection site care, site closure, and emergency & remedial response is demonstrated through the financial test. This firm will maintain active coverage from the effective date of the Class VI permit for the injection well until site closure is authorized by the United States Environmental Protection Agency. The corrective action, injection well plugging, post injection site care, site closure, and emergency & remedial response baseline cost estimate covered by this financial test is established in Appendix H for each of EPA UIC Permits indicated below. The baseline cost is escalated on annual basis.

| | | |
|----------------------------|-------------------------------------|---------------------------------------|
| EPA UIC Permit #: | IL-115-6A-0001 | IL-115-6A-0002 |
| Well Name: | CCS#2 | CCS#1 |
| Location: | 39°53'08.3502"N, 88°53'13.4118"W | 39°52'37.06469"N, 88°53'36.25685"W |
| 2016 Escalated Total Cost: | \$92,523,088 | |

This firm is required to file a Form 10K with the Securities and Exchange Commission (SEC) for the latest fiscal year. The fiscal year of this firm ends on December 31. In Table 1, the following items marked with an asterisk are derived from this firm's independently audited, year-end financial statements for the latest completed fiscal year ended December 31, 2015. Table 2 shows the firm's bond rating test.

Table 1: Financial Coverage Criteria

| | | |
|--|-----|------------------|
| 1. (a) Cost in current dollars for corrective action, injection well plugging, post injection site care and site closure, and/or emergency and remedial response (i.e., all obligations secured by the owner or operator using the financial test) | | \$ 92,500,000 |
| (b) Sum of the company's financial responsibilities currently met using the financial test or corporate guarantee, including CERCLA and RCRA | | \$ 2,000,000 |
| (c) Total of lines a and b | | \$ 94,500,000 |
| 2. Tangible net worth* | | \$14,227,000,000 |
| 3. Current assets* | | \$21,829,000,000 |
| 4. Current liabilities* | | \$13,505,000,000 |
| 5. Net working capital [line3 minus line 4] | | \$8,324,000,000 |
| 6. Total assets* | | \$40,157,000,000 |
| 7. Total assets in U.S.* | | \$28,186,000,000 |
| | Yes | No |
| 8. Is line 2 at least \$100 million? | X | |
| 9. Is line 2 at least 6 times line 1(c)? | X | |
| 10. Is line 5 at least 6 times line 1(c)? | X | |
| 11. Is line 7 at least 90% of Line 6? If not, completed line 12. | | X |
| 12. Is line 7 at least 6 times line 1(c)? | X | |

Table 2: Bond Rating Test

| | |
|---|------------|
| 1. Current bond rating of most recent issuance of this firm and name of rating service (rating service must be either Standard & Poor's or Moody's) | A (S&P) |
| 2. Date of issuance of bond | 10/16/2012 |
| 3. Date of maturity of bond | 04/16/2043 |
| 4. Committee on Uniform Securities Identification Procedures (CUSIP) number | 039483BH4 |

I hereby certify that the wording of this letter is consistent with the wording specified in the Underground Injection Control VI Program Financial Responsibility Guidance (July 2011).



Ray G. Young
 Executive Vice President and
 Chief Financial Officer
 Archer Daniels Midland Company

ATTACHMENT I: STIMULATION PROGRAM

Facility name: Archer Daniels Midland, CCS#2 Well
IL-115-6A-0001
4666 Faries Parkway, Decatur, IL

Well location: Decatur, Macon County, IL;
39°53'08.3502", -88°53'13.4118"

Stimulation to enhance the injectivity potential of the injection zone may be necessary. Stimulation may involve but is not limited to flowing fluids into or out of the well, increasing or connecting pore spaces in the injection formation, or other activities that are intended to allow the injectate to move more readily into the injection formation. Advance notice of all proposed stimulation activities must be provided to the Director, as detailed below, prior to conducting the stimulation. The permittee must describe any fluids to be utilized for stimulation activities and the permittee must demonstrate that the stimulation will not interfere with containment. The permittee must submit proposed procedures for all stimulation activities to the Director in writing at least 30 days in advance, per 40 CFR 146.91(d)(2). Within the 30-day notice period, EPA may: deny the stimulation; approve the stimulation as proposed; or approve the stimulation with conditions. The permittee must carry out the stimulation procedures, including any conditions, as approved or set forth by EPA.



| Monitoring, Reporting, and Verification Plan CCS#2 | | | |
|--|----------------|---------|----------|
| Date Issued | Document # | Version | Page |
| 3/21/2024 | 180.60.ENV.309 | 10.0 | 35 of 37 |

REFERENCE 2

ADM Permit Application for Underground Injection Control Permit, July 2011, including Appendices A-H (Permit Application).



Archer Daniels Midland Company
P.O. Box 1470, Decatur IL 62525

July 25, 2011

Ms. Lisa Perenchio
US Environmental Protection Agency – Region 5
77 W. Jackson Blvd.
Mailcode: WU-16J
Chicago, IL 60604

Re: ADM UIC Class 6 Application
Illinois Carbon Capture and Sequestration project (IL-ICCS)

Dear Ms. Perenchio:

Enclosed are a hard copy and an electronic copy of an Underground Injection Control Permit Application for the Illinois Industrial Carbon Capture and Sequestration project (IL-ICCS) proposed for the Archer Daniels Midland (ADM) Decatur, IL facility.

The goal of the IL-ICCS injection project is to demonstrate the ability of the Mt. Simon Sandstone to accept and retain industrial-scale volumes of carbon dioxide for permanent geologic sequestration. The source of the carbon dioxide is from the fuel ethanol production unit; where high purity biogenic carbon dioxide is produced during the anaerobic fermentation of sugars to alcohol. The project will have an average annual injection rate of between 2,000 and 3,000 metric tonnes per day.

Upon receipt of this application, if you believe it would be beneficial to meet in order to review the application and project scope please let me know. If you have any questions regarding this application please contact Scott McDonald, Project Manager 217-451-5142 or myself at 217-451-6330.

Sincerely,

A handwritten signature in blue ink that reads "Dean Frommelt".

Dean Frommelt
Division Environmental Manager
Corn Processing & BioProducts

Cc: Mark Burau - ADM
Scott McDonald – ADM
Kevin Lesko - IEPA

***UNDERGROUND INJECTION CONTROL
PERMIT APPLICATION
IL – ICCS PROJECT***

Prepared For

ARCHER DANIELS MIDLAND COMPANY

Prepared By



JULY 2011

TABLE OF CONTENTS
ARCHER DANIELS MIDLAND COMPANY
UNDERGROUND INJECTION CONTROL PERMIT APPLICATION
JULY 2011

EXECUTIVE SUMMARY

SECTION 1 – GENERAL INFORMATION

SECTION 2 – HYDROGEOLOGIC INFORMATION

SECTION 3A – INJECTION WELL DESIGN AND CONSTRUCTION DATA

SECTION 3B – VERIFICATION WELL DESIGN AND CONSTRUCTION DATA

SECTION 3C – GEOPHYSICAL WELL DESIGN AND CONSTRUCTION DATA

SECTION 4 – OPERATION PROGRAM AND SURFACE FACILITIES

SECTION 5 – AREA OF REVIEW AND CORRECTIVE ACTION

SECTION 6A – INJECTION WELL MONITORING AND TESTING PLAN

SECTION 6B – VERIFICATION WELL MONITORING AND TESTING PLAN

SECTION 7 – INJECTION FLUID CHARACTERISTICS, COMPATIBILITY, AND PRE-TREATMENT

SECTION 8A – INJECTION WELL PLUGGING AND ABANDONMENT

SECTION 8B – VERIFICATION WELL PLUGGING AND ABANDONMENT

SECTION 8C – GEOPHYSICAL WELL PLUGGING AND ABANDONMENT

SECTION 9 – POST-INJECTION SITE CARE AND SITE CLOSURE

APPENDICES

- A FINANCIAL ASSURANCE DOCUMENTATION
- B CO₂ RESISTANT CEMENT TECHNICAL SPECIFICATIONS
- C SURFACE FACILITIES PIPING & INSTRUMENT DIAGRAMS
- D AREA OF REVIEW WELL DATABASE
- E MATERIALS ANALYSIS PLAN
- F GROUNDWATER MONITORING PLAN
- G PROCEDURES FOR TESTING MECHANICAL INTEGRITY
- H EMERGENCY & REMEDIAL RESPONSE PLAN

EXECUTIVE SUMMARY

Introduction

The Archer Daniels Midland (ADM) Company (“Operator”) proposes an underground injection project (the Illinois Industrial Carbon Capture and Sequestration project or IL-ICCS) at its agricultural products and biofuels production facility located in Decatur, Illinois. The goal of the IL-ICCS injection project is to demonstrate the ability of the Mt. Simon Sandstone to accept and retain industrial-scale volumes of carbon dioxide (CO₂) for permanent geologic sequestration. The source of the CO₂ is from the fuel ethanol production unit; where high purity biogenic CO₂ is produced during the anaerobic fermentation of sugars to alcohol. The Mt. Simon is the deepest sedimentary rock that overlies the Precambrian-age basement granites of the Illinois Basin and is considered a major regional saline-water bearing reservoir in the Illinois Basin. The project will have an average annual injection rate of between 2,000 metric tonnes per day (MT/day) and 3,000 MT/day; approximately 730,000 to 1.1 million MT annually. The project has an initial projected operational period of five years, in which 4.75 million MTs of CO₂ will be sequestered. Following the operational period, the Operator proposes a post-injection monitoring and site closure period of ten (10) years.

The proposed project consists of three major elements; a surface facility, a transmission system, and a sequestration site. The surface facility consists of a 36-inch collection header, two (2) 3,000 hp booster gas blowers, a 1,500 ft 24-inch delivery header, four (4) 3250 hp compressors, a 2,200 MT/day dehydration unit, and three (3) 500 hp booster pumps. The transmission system consists of an 8-inch pipeline that transports the compressed CO₂ to the sequestration site, approximately 1 mile from the surface facility. The sequestration site consists of one injection well (herein referred to as Carbon Capture and Sequestration well #2, or CCS #2) with associated equipment, and two wells (one verification well and one geophysical well) for monitoring of the sequestered CO₂. The surface facilities have a design capacity to capture and condition roughly 2,200 MT/day of CO₂. The transmission and sequestration facilities have the capacity to transport and sequester 3,300 MT/day of CO₂. The additional 1,100 MT/day of CO₂ will come from the surface facilities of the nearby Illinois Basin – Decatur Project (IBDP). These assets will become available when that project completes its 3-year injection period in 2014. After inclusion of these facilities, the project would operate continuously at a capacity to collect all the available CO₂ from the biofuels facility,

targeting a carbon capture and storage capacity of up to 1.1 million MT per year by 2015. The captured CO₂ would be compressed, conditioned, transported via pipeline to the injection well, and injected into the Mount Simon Sandstone reservoir for permanent geologic sequestration.

While this application proposes a defined operational duration, the Operator may extend this period as per the requirements detailed in 40 CFR 146 Subpart H – Criteria and Standards Applicable to Class VI Wells.

The IL-ICCS project is separate from the nearby IBDP, which is permitted to inject 1.0 million MTs of CO₂ into the Mt. Simon over a 3-year period, beginning in 2011. CO₂ injection from both the IBDP and the IL-ICCS injection wells will occur simultaneously for about 2 years at which the IBDP concludes the injection period. Following the dual injection period, the CO₂ stream used for the IBDP will be diverted to the ICCS project bringing the maximum injection capacity to 3,300 MT/day.

The proposed sequestration site at the ADM facility will be supplied with 99.9 percent pure CO₂ from the ethanol production plant. The CO₂ produced from fermentation is water saturated and delivered at near atmospheric pressure. After collection, the CO₂ will be dehydrated and compressed to supercritical conditions up to a maximum of 2,550 psi. The dehydration and compression facility is planned to be located near the north boundary of the ADM facility; after which the CO₂ will be transported about one mile through an 8-inch pipe to the injection well location. The injection well will be located on an ADM owned land tract that is adjacent to their industrial complex.

The project, led by ADM, would include participation from the Illinois State Geological Survey (ISGS), Schlumberger Carbon Services (SCS), Richland Community College (RCC), and the Department of Energy – National Energy Technology Laboratory (NETL). During this project, ADM will leverage the knowledge and experience gained through the IBDP to design, construct, and operate the CO₂ collection, compression, dehydration, and injection facility capable of delivering and sequestering over 1 million MTs per year of CO₂ into the Mt. Simon.

The construction phase of the project is expected to last 18-24 months allowing the commissioning and operation of the facility to occur in the second half of 2012. During the first two years of operation, this project will be able to monitor the effects of simultaneous CO₂ injection from the separate wells. This data will be base lined against the data developed during the IBDP's single well injection period. The data developed during the dual-well injection period will be critical in the development of models for large scale industrial sequestration projects. Additionally, demonstration of this technology will provide an economic baseline for other biofuel production facilities.

Injection Plan

The proposed mass to be injected is nominally 2,000 - 3,000 MT/day of supercritical CO₂ with a cumulative mass of 4.75 million tons over five years and is scheduled to begin in the second half of 2012. The CO₂ will be supplied from the ADM fuel ethanol production unit located at the Decatur, Illinois agricultural products and biofuels production facility. Injection rates will be metered and should remain continuous during the injection period.

Based on regional and local geology, the specific injection interval within the Mt. Simon is expected to be near the base of the sandstone formation. The injection interval will be identified based on well logs and core samples from the initial well drilled on the site. For the anticipated Mt. Simon net thickness and permeability, reservoir modeling and nodal analyses suggest that a single injection well with 9-5/8 inch diameter long-string casing and 4.5-inch diameter tubing will be adequate to meet the maximum 3,300 MT/day injection rate (modeling data is detailed in Section 5 of this application).

Anticipating that the lower interval has sufficient injectivity and is selected as the injection interval, the well completion (perforation of the injection zone) will occur after the well is drilled and cased.

During the period prior to injection, assessment of perforation strategies and subsequent modeling to predict the behavior of the CO₂ plume based on the data collected during the CCS #2 injection well installation will take place. Permeability-thickness product and injectivity of several sub-intervals within the Mt. Simon will be quantified and assessed to fully understand the

impact of lower permeability interval(s) within the Mt. Simon to the distribution of the buoyant CO₂ plume.

Supplemental Monitoring

A shallow groundwater monitoring program is discussed in Section 6A of this application. The environmental monitoring program will benefit from the data and experience ISGS developed during the IBDP as well as several other small-scale enhanced oil recovery (EOR) pilots in Illinois where fresh water, brine, other reservoir fluids, and gases were sampled and analyzed.

The pre-CO₂ injection geologic baseline will be established with geophysical well logs, 2D and 3D seismic surveys. Geophysical monitoring will continue during injection (five years) and post-injection (10 years) periods.

Pre-injection 3D seismic imagery has already been acquired and will provide an improved understanding of the geologic structure, which is expected to have a regional dip of about 0.5 degrees to the southeast. The extensive suite of data to be collected in and around the CCS #2 injection well through core analyses and petrophysical tests, borehole tests, and well logging will be analyzed and used to build models of the site geology from the Mt. Simon to the surface. Reservoir flow modeling will be used to history match the injection performance and predict the distribution of the CO₂ plume. The IL-ICCS project's verification and geophysical wells will provide additional datasets to further understand the CO₂ plume movement, lateral variations in the geologic and reservoir properties of the Mt. Simon.

Injection Fluid

The proposed sequestration site at the ADM facility will be supplied with nearly pure CO₂ from the biofuel production plant at their Decatur, Illinois agricultural processing facility. Outlet CO₂ streams are downstream of wet gas scrubbers from anaerobic biofuel fermentor vents. The stream is typically greater than 99.9% pure CO₂. It is saturated with water vapor at 100°F and at slightly greater than atmospheric pressure. Common impurities (in amounts typically less than 200 ppm by volume) are nitrogen, oxygen, methanol, acetaldehyde and hydrogen sulfide.

SECTION 1 - GENERAL INFORMATION

This document is organized as noted in Table 1-1 below.

| Table 1-1. UIC Permit Application Organization | |
|---|---|
| Document Section | Contents |
| 1 | General Information |
| 2 | Hydrogeologic Information |
| 3A | Injection Well Design and Construction Data |
| 3B | Verification Well Design and Construction Data |
| 3C | Geophysical Monitoring Well Design and Construction Data |
| 4 | Operation Program and Surface Facilities |
| 5 | Area of Review |
| 6A | Injection Well Monitoring, Integrity Testing, and Contingency Plan |
| 6B | Verification Well Monitoring, Integrity Testing, and Contingency Plan |
| 7 | Characteristics, Compatibility, and Pre- Treatment of Injection Fluid |
| 8A | Injection Well Plugging & Abandonment Procedures |
| 8B | Verification Well Plugging & Abandonment Procedures |
| 8C | Geophysical Monitoring Well Plugging & Abandonment Procedures |
| 9 | Post-Injection Site Care and Site Closure Plan |

Following completion of the well installations for this project, the Well Completion Report will be completed and submitted to the permitting agency.

This document contains the information required by Federal regulations (40 CFR Part 146, Subpart H) for underground injection of carbon dioxide for geologic sequestration (Class VI injection wells). Page 1-6 provides general information required for all UIC permits (40 CFR 144.31(e)(1)-(6)). Table 1-2 provides a cross-reference to demonstrate that the Federal regulation requirements of 40 CFR 146 Subpart H are met within the format of this UIC permit application.

A list of abbreviations used in this UIC application are provided following Table 1-2.

Required USEPA Forms 7520-6 (Underground Injection Control Permit Application) and 7520-14 (Plugging and Abandonment Plan) are provided at the end of this section. A 7520-14 form is provided for both the proposed injection well and verification well.

Information required for all Underground Injection Control permits:

1. Applicant Information:

Applicant: Archer Daniels Midland Company – Corn Processing
USEPA Identification No. ILD984791459
IEPA Identification No. 1150155136
Facility Contact: Mr. Dean Frommelt, Division Environmental Manager
Mailing Address: 4666 Faries Parkway
Decatur, IL 62526
Phone: 217-451-6330

2. Site Information:

County: Macon
SIC Codes: 2046 – wet corn milling
2869 – industrial organic chemicals, ethanol
2075 – soybean oil mills
2076 – vegetable oil mills
Owner/Operator: Archer Daniels Midland Company – Corn Processing
4666 Faries Parkway
Decatur, IL 62526
Operator Status: Private
Phone: 1-800-637-5843
Indian Lands: The site is not located on Indian lands.

3. Existing Environmental Permits:

NPDES Industrial Storm Water Permit IL0061425
UIC ADM-UIC-012
RCRA None
Other Various air permits, including Title V Clean Air Act Permit
(#1711500005)
Other Sanitary District of Decatur Pre-Treatment, Permit #200

4. Nature of Business:

Archer Daniels Midland Company (ADM) is the world leader in BioEnergy and has a premier position in the agricultural processing value chain. ADM is one of the world's largest processors of soybeans, corn, wheat, and cocoa. ADM is a leading manufacturer of biodiesel, ethanol, soybean oil and meal, corn sweeteners, flour, and other value-added food and feed ingredients. Headquartered in Decatur, Illinois, ADM has over 29,000 employees, more than 240 processing plants, and net sales for the fiscal year ending June 30, 2010 of \$62 billion. Additional information can be found on ADM's Web site at <http://www.admworld.com>.

**Table 1-2. Cross-Reference Table to Class VI Injection Well Rules
(40 CFR Part 146, Subpart H—Criteria and Standards Applicable to Class VI Wells)**

| Class VI Well Regulatory Requirements | Application Section Where Addressed |
|--|---|
| <p>Sec. 146.82 Required Class VI permit information. (a) Prior to the issuance of a permit for the construction of a new Class VI well or the conversion of an existing Class I, Class II, or Class V well to a Class VI well, the owner or operator shall submit, pursuant to § 146.91(e), and the Director shall consider the following:</p> | |
| (1) Information required in § 144.31(e)(1) through (6) of this chapter; | Section 1, p. 1-7 |
| (2) A map showing the injection well for which a permit is sought and the applicable area of review consistent with § 146.84. Within the area of review, the map must show the number or name, and location of all injection wells, producing wells, abandoned wells, plugged wells or dry holes, deep stratigraphic boreholes, State- or EPA-approved subsurface cleanup sites, surface bodies of water, springs, mines (surface and subsurface), quarries, water wells, other pertinent surface features including structures intended for human occupancy, State, Tribal, and Territory boundaries, and roads. The map should also show faults, if known or suspected. Only information of public record is required to be included on this map; | Fig. 2-35 Fig. 5-2 Appendix D |
| (3) Information on the geologic structure and hydrogeologic properties of the proposed storage site and overlying formations, including: <ul style="list-style-type: none"> (i) Maps and cross sections of the area of review; (ii) The location, orientation, and properties of known or suspected faults and fractures that may transect the confining zone(s) in the area of review and a determination that they would not interfere with containment; (iii) Data on the depth, areal extent, thickness, mineralogy, porosity, permeability, and capillary pressure of the injection and confining zone(s); including geology/facies changes based on field data which may include geologic cores, outcrop data, seismic surveys, well logs, and names and lithologic descriptions; (iv) Geomechanical information on fractures, stress, ductility, rock strength, and in situ fluid pressures within the confining zone(s); (v) Information on the seismic history including the presence and depth of seismic sources and a determination that the seismicity would not interfere with containment; and (vi) Geologic and topographic maps and cross sections illustrating regional geology, hydrogeology, and the geologic structure of the local area. | Section 2 Figs. 2-2 to 2-7 Sec. 2.2 Section 2 (Sects 2.4 and 2.5), Section 5.4.2 Sec. 2.5.3.2 Sec. 2.2.1 Figs. 2-1 to 2-9, 2-16 to 2-35 |
| (4) A tabulation of all wells within the area of review which penetrate the injection or confining zone(s). Such data must include a description of each well's type, construction, date drilled, location, depth, record of plugging and/ or completion, and any additional information the Director may require; | Section 5.5 Appendix D |
| (5) Maps and stratigraphic cross sections indicating the general vertical and lateral limits of all USDWs, water wells and springs within the area of review, their positions relative to the injection zone(s), and the direction of water movement, where known; | Sec. 2.7.2 Fig. 2-22 to 33 |
| (6) Baseline geochemical data on subsurface formations, including all USDWs in the area of review; | Sections 2.4.4, 2.7.2, Figs. 2-22 to 2-34 |
| (7) Proposed operating data for the proposed geologic sequestration site: <ul style="list-style-type: none"> (i) Average and maximum daily rate and volume and/or mass and total anticipated volume and/or mass of the carbon dioxide stream; (ii) Average and maximum injection pressure; (iii) The source(s) of the carbon dioxide stream; and (iv) An analysis of the chemical and physical characteristics of the carbon dioxide stream. | Section 4.1.4 Section 4.1.8 Section 7.2 Section 7.4 |
| (8) Proposed pre-operational formation testing program to obtain an analysis of the chemical and physical characteristics of the injection zone(s) and confining zone(s) and that meets the requirements at § 146.87; | Sections 3A.7 and 3A.9 |

| | |
|---|---------------------------------|
| Sec. 146.82 Required Class VI permit information. (cont'd) | |
| (9) Proposed stimulation program, a description of stimulation fluids to be used and a determination that stimulation will not interfere with containment; | Section 3A.9.2 |
| (10) Proposed procedure to outline steps necessary to conduct injection operation; | Section 4.2 Section 6A.2.2.3 |
| (11) Schematics or other appropriate drawings of the surface and subsurface construction details of the well; | Figs. 3A-1, 3A-2 |
| (12) Injection well construction procedures that meet the requirements of § 146.86; | Section 3A |
| (13) Proposed area of review and corrective action plan that meets the requirements under § 146.84; | Section 5.6 |
| (14) A demonstration, satisfactory to the Director, that the applicant has met the financial responsibility requirements under § 146.85; | Appendix A |
| (15) Proposed testing and monitoring plan required by § 146.90; | Section 6A |
| (16) Proposed injection well plugging plan required by § 146.92(b); | Section 8A |
| (17) Proposed post-injection site care and site closure plan required by § 146.93(a); | Section 9 |
| (18) At the Director's discretion, a demonstration of an alternative post-injection site care timeframe required by § 146.93(c); | Section 9.1.5 |
| (19) Proposed emergency and remedial response plan required by § 146.94(a); | Appendix H |
| (20) A list of contacts, submitted to the Director, for those States, Tribes, and Territories identified to be within the area of review of the Class VI project based on information provided in paragraph (a)(2) of this section; and | Section 5.6 |
| (21) Any other information requested by the Director. | Agency action |
| (b) The Director shall notify, in writing, any States, Tribes, or Territories identified to be within the area of review of the Class VI project based on information provided in paragraphs (a)(2) and (a)(20) of this section of the permit application and pursuant to the requirements at § 145.23(f)(13) of this chapter. | Agency action |
| (c) Prior to granting approval for the operation of a Class VI well, the Director shall consider the following information: (1) The final area of review based on modeling, using data obtained during logging and testing of the well and the formation as required by paragraphs (c)(2), (3), (4), (6), (7), and (10) of this section; (2) Any relevant updates, based on data obtained during logging and testing of the well and the formation as required by paragraphs (c)(3), (4), (6), (7), and (10) of this section, to the information on the geologic structure and hydrogeologic properties of the proposed storage site and overlying formations, submitted to satisfy the requirements of paragraph (a)(3) of this section; (3) Information on the compatibility of the carbon dioxide stream with fluids in the injection zone(s) and minerals in both the injection and the confining zone(s), based on the results of the formation testing program, and with the materials used to construct the well; (4) The results of the formation testing program required at paragraph (a)(8) of this section; (5) Final injection well construction procedures that meet the requirements of § 146.86; (6) The status of corrective action on wells in the area of review; (7) All available logging and testing program data on the well required by § 146.87; (8) A demonstration of mechanical integrity pursuant to § 146.89; (9) Any updates to the proposed area of review and corrective action plan, testing and monitoring plan, injection well plugging plan, post-injection site care and site closure plan, or the emergency and remedial response plan submitted under paragraph (a) of this section, which are necessary to address new information collected during logging and testing of the well and the formation as required by all paragraphs of this section, and any updates to the alternative post-injection site care timeframe demonstration submitted under paragraph (a) of this section, which are necessary to address new information collected during the logging and testing of the well and the formation as required by all paragraphs of this section; and (10) Any other information requested by the Director. | Agency action |
| (d) Owners or operators seeking a waiver of the requirement to inject below the lowermost USDW must also refer to § 146.95 and submit a supplemental report, as required at § 146.95(a). The supplemental report is not part of the permit application. | Not applicable |

| | |
|---|---------------|
| <p>§ 146.83 Minimum criteria for siting.</p> <p>(a) Owners or operators of Class VI wells must demonstrate to the satisfaction of the Director that the wells will be sited in areas with a suitable geologic system. The owners or operators must demonstrate that the geologic system comprises:</p> <p>(1) An injection zone(s) of sufficient areal extent, thickness, porosity, and permeability to receive the total anticipated volume of the carbon dioxide stream;</p> <p>(2) Confining zone(s) free of transmissive faults or fractures and of sufficient areal extent and integrity to contain the injected carbon dioxide stream and displaced formation fluids and allow injection at proposed maximum pressures and volumes without initiating or propagating fractures in the confining zone(s).</p> | Section 2 |
| <p>(b) The Director may require owners or operators of Class VI wells to identify and characterize additional zones that will impede vertical fluid movement, are free of faults and fractures that may interfere with containment, allow for pressure dissipation, and provide additional opportunities for monitoring, mitigation, and remediation.</p> | Agency action |

| | |
|---|----------------------|
| <p>§ 146.84 Area of review and corrective action.</p> <p>(a) The area of review is the region surrounding the geologic sequestration project where USDWs may be endangered by the injection activity. The area of review is delineated using computational modeling that accounts for the physical and chemical properties of all phases of the injected carbon dioxide stream and is based on available site characterization, monitoring, and operational data.</p> | Sections 5.1 and 5.2 |
| <p>(b) The owner or operator of a Class VI well must prepare, maintain, and comply with a plan to delineate the area of review for a proposed geologic sequestration project, periodically reevaluate the delineation, and perform corrective action that meets the requirements of this section and is acceptable to the Director. The requirement to maintain and implement an approved plan is directly enforceable regardless of whether the requirement is a condition of the permit. As a part of the permit application for approval by the Director, the owner or operator must submit an area of review and corrective action plan that includes the following information:</p> | Section 5.6 |
| <p>(1) The method for delineating the area of review that meets the requirements of paragraph (c) of this section, including the model to be used, assumptions that will be made, and the site characterization data on which the model will be based;</p> | Sections 5.1 and 5.2 |
| <p>(2) A description of:</p> <p>(i) The minimum fixed frequency, not to exceed five years, at which the owner or operator proposes to reevaluate the area of review;</p> <p>(ii) The monitoring and operational conditions that would warrant a reevaluation of the area of review prior to the next scheduled reevaluation as determined by the minimum fixed frequency established in paragraph (b)(2)(i) of this section.</p> <p>(iii) How monitoring and operational data (e.g., injection rate and pressure) will be used to inform an area of review reevaluation; and</p> <p>(iv) How corrective action will be conducted to meet the requirements of paragraph (d) of this section, including what corrective action will be performed prior to injection and what, if any, portions of the area of review will have corrective action addressed on a phased basis and how the phasing will be determined; how corrective action will be adjusted if there are changes in the area of review; and how site access will be guaranteed for future corrective action.</p> | Section 5.6 |
| <p>(c) Owners or operators of Class VI wells must perform the following actions to delineate the area of review and identify all wells that require corrective action:</p> <p>(1) Predict, using existing site characterization, monitoring and operational data, and computational modeling, the projected lateral and vertical migration of the carbon dioxide plume and formation fluids in the subsurface from the commencement of injection activities until the plume movement ceases, until pressure differentials sufficient to cause the movement of injected fluids or formation fluids into a USDW are no longer present, or until the end of a fixed time period as determined by the Director. The model must:</p> <p>(i) Be based on detailed geologic data collected to characterize the injection zone(s), confining zone(s) and any additional zones; and anticipated operating data, including injection pressures, rates, and total volumes over the proposed life of the geologic sequestration project;</p> <p>(ii) Take into account any geologic heterogeneities, other discontinuities, data quality, and their possible impact on model predictions; and</p> <p>(iii) Consider potential migration through faults, fractures, and artificial penetrations.</p> <p>(iv)</p> | Section 5.4 |

| | |
|--|--|
| <p>§ 146.86 Injection well construction requirements. (a) <i>General.</i> The owner or operator must ensure that all Class VI wells are constructed and completed to: (1) Prevent the movement of fluids into or between USDWs or into any unauthorized zones; (2) Permit the use of appropriate testing devices and workover tools; and (3) Permit continuous monitoring of the annulus space between the injection tubing and long string casing.</p> | Section 3A.7 |
| <p>(b) <i>Casing and Cementing of Class VI Wells.</i> (1) Casing and cement or other materials used in the construction of each Class VI well must have sufficient structural strength and be designed for the life of the geologic sequestration project. All well materials must be compatible with fluids with which the materials may be expected to come into contact and must meet or exceed standards developed for such materials by the American Petroleum Institute, ASTM International, or comparable standards acceptable to the Director. The casing and cementing program must be designed to prevent the movement of fluids into or between USDWs. In order to allow the Director to determine and specify casing and cementing requirements, the owner or operator must provide the following information: (i) Depth to the injection zone(s); (ii) Injection pressure, external pressure, internal pressure, and axial loading; (iii) Hole size; (iv) Size and grade of all casing strings (wall thickness, external diameter, nominal weight, length, joint specification, and construction material); (v) Corrosiveness of the carbon dioxide stream and formation fluids; (vi) Down-hole temperatures; (vii) Lithology of injection and confining zone(s); (viii) Type or grade of cement and cement additives; and (ix) Quantity, chemical composition, and temperature of the carbon dioxide stream.</p> | <p>Section 3A.7</p> <p>Section 3A.1</p> <p>Section 3A.7.1 Section 3A.7.2</p> <p>Section 7.5 Section 2.4.4.1 Section 2.4, 2.5 Sect. 3A.7.4 Section 7.3, 7.4</p> |
| <p>(2) Surface casing must extend through the base of the lowermost USDW and be cemented to the surface through the use of a single or multiple strings of casing and cement.</p> | Section 3A.7.1 |
| <p>(3) At least one long string casing, using a sufficient number of centralizers, must extend to the injection zone and must be cemented by circulating cement to the surface in one or more stages.</p> | Section 3A.7.4 |
| <p>(4) Circulation of cement may be accomplished by staging. The Director may approve an alternative method of cementing in cases where the cement cannot be recirculated to the surface, provided the owner or operator can demonstrate by using logs that the cement does not allow fluid movement behind wellbore.</p> | Section 3A.7.4 |
| <p>(5) Cement and cement additives must be compatible with the carbon dioxide stream and formation fluids and of sufficient quality and quantity to maintain integrity over the design life of the geologic sequestration project. The integrity and location of the cement shall be verified using technology capable of evaluating cement quality radially and identifying the location of channels to ensure that USDWs are not endangered.</p> | Section 3A.7.4 Section 7.5.3.2 Appendix B |
| <p>(c) <i>Tubing and packer.</i> (1) Tubing and packer materials used in the construction of each Class VI well must be compatible with fluids with which the materials may be expected to come into contact and must meet or exceed standards developed for such materials by the American Petroleum Institute, ASTM International, or comparable standards acceptable to the Director.</p> | Section 3A.7.3 Section 3A.7.5 |
| <p>(2) All owners or operators of Class VI wells must inject fluids through tubing with a packer set at a depth opposite a cemented interval at the location approved by the Director.</p> | Section 3A.7.3 |
| <p>(3) In order for the Director to determine and specify requirements for tubing and packer, the owner or operator must submit the following information: (i) Depth of setting; (ii) Characteristics of the carbon dioxide stream (chemical content, corrosiveness, temperature, and density) and formation fluids; (iii) Maximum proposed injection pressure; (iv) Maximum proposed annular pressure; (v) Proposed injection rate (intermittent or continuous) and volume and/or mass of the carbon dioxide stream; (vi) Size of tubing and casing; and (vii) Tubing tensile, burst, and collapse strengths.</p> | <p>Packer depth TBD. Section 7</p> <p>Section 4.1.8 Section 4.1.9 Section 4.1.4</p> <p>Section 3A.7.2 Section 3A.7.3</p> |

| | |
|--|--|
| <p>§ 146.87 Logging, sampling, and testing prior to injection well operation.</p> <p>(a) During the drilling and construction of a Class VI injection well, the owner or operator must run appropriate logs, surveys and tests to determine or verify the depth, thickness, porosity, permeability, and lithology of, and the salinity of any formation fluids in all relevant geologic formations to ensure conformance with the injection well construction requirements under § 146.86 and to establish accurate baseline data against which future measurements may be compared. The owner or operator must submit to the Director a descriptive report prepared by a knowledgeable log analyst that includes an interpretation of the results of such logs and tests. At a minimum, such logs and tests must include:</p> <p>(1) Deviation checks during drilling on all holes constructed by drilling a pilot hole which is enlarged by reaming or another method. Such checks must be at sufficiently frequent intervals to determine the location of the borehole and to ensure that vertical avenues for fluid movement in the form of diverging holes are not created during drilling; and</p> <p>(2) Before and upon installation of the surface casing:</p> <p>(i) Resistivity, spontaneous potential, and caliper logs before the casing is installed; and</p> <p>(ii) A cement bond and variable density log to evaluate cement quality radially, and a temperature log after the casing is set and cemented.</p> <p>(3) Before and upon installation of the long string casing:</p> <p>(i) Resistivity, spontaneous potential, porosity, caliper, gamma ray, fracture finder logs, and any other logs the Director requires for the given geology before the casing is installed; and</p> <p>(ii) A cement bond and variable density log, and a temperature log after the casing is set and cemented.</p> <p>(4) A series of tests designed to demonstrate the internal and external mechanical integrity of injection wells, which may include:</p> <p>(i) A pressure test with liquid or gas;</p> <p>(ii) A tracer survey such as oxygen-activation logging;</p> <p>(iii) A temperature or noise log;</p> <p>(iv) A casing inspection log; and</p> <p>(5) Any alternative methods that provide equivalent or better information and that are required by and/or approved of by the Director.</p> | <p>Section 3A.7</p> <p>Section 3A.9.1 Section 3A.9.2</p> <p>Section 3A.9.1 Section 3A.9.2</p> <p>Section 3A.9.3</p> <p>Agency action</p> |
| <p>(b) The owner or operator must take whole cores or sidewall cores of the injection zone and confining system and formation fluid samples from the injection zone(s), and must submit to the Director a detailed report prepared by a log analyst that includes: Well log analyses (including well logs), core analyses, and formation fluid sample information. The Director may accept information on cores from nearby wells if the owner or operator can demonstrate that core retrieval is not possible and that such cores are representative of conditions at the well. The Director may require the owner or operator to core other formations in the borehole.</p> | <p>Section 3A.9.1</p> |
| <p>(c) The owner or operator must record the fluid temperature, pH, conductivity, reservoir pressure, and static fluid level of the injection zone(s).</p> | <p>Section 3A.9.1</p> |
| <p>(d) At a minimum, the owner or operator must determine or calculate the following information concerning the injection and confining zone(s):</p> <p>(1) Fracture pressure;</p> <p>(2) Other physical and chemical characteristics of the injection and confining zone(s); and</p> <p>(3) Physical and chemical characteristics of the formation fluids in the injection zone(s).</p> | <p>Section 3A.9.1</p> |
| <p>(e) Upon completion, but prior to operation, the owner or operator must conduct the following tests to verify hydrogeologic characteristics of the injection zone(s):</p> <p>(1) A pressure fall-off test; and,</p> <p>(2) A pump test; or</p> <p>(3) Injectivity tests.</p> | <p>Section 3A.9.2</p> |
| <p>(f) The owner or operator must provide the Director with the opportunity to witness all logging and testing by this subpart. The owner or operator must submit a schedule of such activities to the Director 30 days prior to conducting the first test and submit any changes to the schedule 30 days prior to the next scheduled test.</p> | <p>Section 3A.9</p> |

| | |
|---|--|
| <p>§ 146.88 Injection well operating requirements.</p> <p>(a) Except during stimulation, the owner or operator must ensure that injection pressure does not exceed 90 percent of the fracture pressure of the injection zone(s) so as to ensure that the injection does not initiate new fractures or propagate existing fractures in the injection zone(s). In no case may injection pressure initiate fractures in the confining zone(s) or cause the movement of injection or formation fluids that endangers a USDW. Pursuant to requirements at § 146.82(a)(9), all stimulation programs must be approved by the Director as part of the permit application and incorporated into the permit.</p> | Section 6A.2.2 |
| <p>(b) Injection between the outermost casing protecting USDWs and the well bore is prohibited.</p> | Section 4.1.9 |
| <p>(c) The owner or operator must fill the annulus between the tubing and the long string casing with a non-corrosive fluid approved by the Director. The owner or operator must maintain on the annulus a pressure that exceeds the operating injection pressure, unless the Director determines that such requirement might harm the integrity of the well or endanger USDWs.</p> | Section 6A.3.1 Section 3A.7.5 |
| <p>(d) Other than during periods of well workover (maintenance) approved by the Director in which the sealed tubing-casing annulus is disassembled for maintenance or corrective procedures, the owner or operator must maintain mechanical integrity of the injection well at all times.</p> | Section 6A.3 |
| <p>(e) The owner or operator must install and use:</p> <p>(1) Continuous recording devices to monitor: The injection pressure; the rate, volume and/or mass, and temperature of the carbon dioxide stream; and the pressure on the annulus between the tubing and the long string casing and annulus fluid volume; and</p> <p>(2) Alarms and automatic surface shut-off systems or, at the discretion of the Director, down-hole shut-off systems (<i>e.g.</i>, automatic shut-off, check valves) for onshore wells or, other mechanical devices that provide equivalent protection; and</p> <p>(3) Alarms and automatic down-hole shut-off systems for wells located offshore but within State territorial waters, designed to alert the operator and shut-in the well when operating parameters such as annulus pressure, injection rate, or other parameters diverge beyond permitted ranges and/or gradients specified in the permit.</p> | Section 6A.2.1 Section 6A.2.2 Not applicable |
| <p>(f) If a shutdown (<i>i.e.</i>, down-hole or at the surface) is triggered or a loss of mechanical integrity is discovered, the owner or operator must immediately investigate and identify as expeditiously as possible the cause of the shutoff. If, upon such investigation, the well appears to be lacking mechanical integrity, or if monitoring required under paragraph (e) of this section otherwise indicates that the well may be lacking mechanical integrity, the owner or operator must:</p> <p>(1) Immediately cease injection;</p> <p>(2) Take all steps reasonably necessary to determine whether there may have been a release of the injected carbon dioxide stream or formation fluids into any unauthorized zone;</p> <p>(3) Notify the Director within 24 hours;</p> <p>(4) Restore and demonstrate mechanical integrity to the satisfaction of the Director prior to resuming injection; and</p> <p>(5) Notify the Director when injection can be expected to resume.</p> | Section 6A.4 Appendix H |

| | |
|---|----------------|
| <p>§ 146.89 Mechanical integrity. (a) A Class VI well has mechanical integrity if: (1) There is no significant leak in the casing, tubing, or packer; and (2) There is no significant fluid movement into a USDW through channels adjacent to the injection well bore.</p> | Section 6A.3 |
| <p>(b) To evaluate the absence of significant leaks under paragraph (a)(1) of this section, owners or operators must, following an initial annulus pressure test, continuously monitor injection pressure, rate, injected volumes; pressure on the annulus between tubing and long-string casing; and annulus fluid volume as specified in § 146.88 (e);</p> | Section 6A.3.1 |
| <p>(c) At least once per year, the owner or operator must use one of the following methods to determine the absence of significant fluid movement under paragraph (a)(2) of this section: (1) An approved tracer survey such as an oxygen-activation log; or (2) A temperature or noise log.</p> | Section 6A.3.2 |
| <p>(d) If required by the Director, at a frequency specified in the testing and monitoring plan required at § 146.90, the owner or operator must run a casing inspection log to determine the presence or absence of corrosion in the long-string casing.</p> | Agency action |
| <p>(e) The Director may require any other test to evaluate mechanical integrity under paragraphs (a)(1) or (a)(2) of this section. Also, the Director may allow the use of a test to demonstrate mechanical integrity other than those listed above with the written approval of the Administrator. To obtain approval for a new mechanical integrity test, the Director must submit a written request to the Administrator setting forth the proposed test and all technical data supporting its use. The Administrator may approve the request if he or she determines that it will reliably demonstrate the mechanical integrity of wells for which its use is proposed. Any alternate method approved by the Administrator will be published in the Federal Register and may be used in all States in accordance with applicable State law unless its use is restricted at the time of approval by the Administrator.</p> | Agency action |
| <p>(f) In conducting and evaluating the tests enumerated in this section or others to be allowed by the Director, the owner or operator and the Director must apply methods and standards generally accepted in the industry. When the owner or operator reports the results of mechanical integrity tests to the Director, he/she shall include a description of the test(s) and the method(s) used. In making his/her evaluation, the Director must review monitoring and other test data submitted since the previous evaluation.</p> | Section 6A.3.2 |
| <p>(g) The Director may require additional or alternative tests if the results presented by the owner or operator under paragraphs (a) through (d) of this section are not satisfactory to the Director to demonstrate that there is no significant leak in the casing, tubing, or packer, or to demonstrate that there is no significant movement of fluid into a USDW resulting from the injection activity as stated in paragraphs (a)(1) and (2) of this section.</p> | Agency action |

| | |
|---|----------------------------------|
| <p>§ 146.90 Testing and monitoring requirements. The owner or operator of a Class VI well must prepare, maintain, and comply with a testing and monitoring plan to verify that the geologic sequestration project is operating as permitted and is not endangering USDWs. The requirement to maintain and implement an approved plan is directly enforceable regardless of whether the requirement is a condition of the permit. The testing and monitoring plan must be submitted with the permit application, for Director approval, and must include a description of how the owner or operator will meet the requirements of this section, including accessing sites for all necessary monitoring and testing during the life of the project. Testing and monitoring associated with geologic sequestration projects must, at a minimum, include:</p> | Section 6A.2 |
| (a) Analysis of the carbon dioxide stream with sufficient frequency to yield data representative of its chemical and physical characteristics; | Section 6A.1 |
| (b) Installation and use, except during well workovers as defined in § 146.88(d), of continuous recording devices to monitor injection pressure, rate, and volume; the pressure on the annulus between the tubing and the long string casing; and the annulus fluid volume added; | Section 6A.2.1 Section 6A.3.1 |
| (c) Corrosion monitoring of the well materials for loss of mass, thickness, cracking, pitting, and other signs of corrosion, which must be performed on a quarterly basis to ensure that the well components meet the minimum standards for material strength and performance set forth in § 146.86(b), by: (1) Analyzing coupons of the well construction materials placed in contact with the carbon dioxide stream; or (2) Routing the carbon dioxide stream through a loop constructed with the material used in the well and inspecting the materials in the loop; or (3) Using an alternative method approved by the Director; | Section 6A.3.4 |
| (d) Periodic monitoring of the ground water quality and geochemical changes above the confining zone(s) that may be a result of carbon dioxide movement through the confining zone(s) or additional identified zones including: (1) The location and number of monitoring wells based on specific information about the geologic sequestration project, including injection rate and volume, geology, the presence of artificial penetrations, and other factors; and (2) The monitoring frequency and spatial distribution of monitoring wells based on baseline geochemical data that has been collected under § 146.82(a)(6) and on any modeling results in the area of review evaluation required by § 146.84(c). | Section 6A.2.3 Appendix F |
| (e) A demonstration of external mechanical integrity pursuant to § 146.89(c) at least once per year until the injection well is plugged; and, if required by the Director, a casing inspection log pursuant to requirements at § 146.89(d) at a frequency established in the testing and monitoring plan; | Section 6A.3.2 |
| (f) A pressure fall-off test at least once every five years unless more frequent testing is required by the Director based on site-specific information; | Section 6A.3.3 |
| (g) Testing and monitoring to track the extent of the carbon dioxide plume and the presence or absence of elevated pressure (<i>e.g.</i> , the pressure front) by using: (1) Direct methods in the injection zone(s); and, (2) Indirect methods (<i>e.g.</i> , seismic, electrical, gravity, or electromagnetic surveys and/or down-hole carbon dioxide detection tools), unless the Director determines, based on site-specific geology, that such methods are not appropriate; | Section 6A.2.5 |

| | |
|---|----------------|
| <p>§ 146.90 Testing and monitoring requirements. (cont'd)</p> <p>(h) The Director may require surface air monitoring and/or soil gas monitoring to detect movement of carbon dioxide that could endanger a USDW.</p> <p>(1) Design of Class VI surface air and/ or soil gas monitoring must be based on potential risks to USDWs within the area of review;</p> <p>(2) The monitoring frequency and spatial distribution of surface air monitoring and/or soil gas monitoring must be decided using baseline data, and the monitoring plan must describe how the proposed monitoring will yield useful information on the area of review delineation and/or compliance with standards under § 144.12 of this chapter;</p> <p>(3) If an owner or operator demonstrates that monitoring employed under §§ 98.440 to 98.449 of this chapter (Clean Air Act, 42 U.S.C. 7401 <i>et seq.</i>) accomplishes the goals of paragraphs (h)(1) and (2) of this section, and meets the requirements pursuant to § 146.91(c)(5), a Director that requires surface air/soil gas monitoring must approve the use of monitoring employed under §§ 98.440 to 98.449 of this chapter. Compliance with §§ 98.440 to 98.449 of this chapter pursuant to this provision is considered a condition of the Class VI permit;</p> | Section 6A.2.6 |
| <p>(i) Any additional monitoring, as required by the Director, necessary to support, upgrade, and improve computational modeling of the area of review evaluation required under § 146.84(c) and to determine compliance with standards under § 144.12 of this chapter;</p> | Agency action |
| <p>(j) The owner or operator shall periodically review the testing and monitoring plan to incorporate monitoring data collected under this subpart, operational data collected under § 146.88, and the most recent area of review reevaluation performed under § 146.84(e). In no case shall the owner or operator review the testing and monitoring plan less often than once every five years. Based on this review, the owner or operator shall submit an amended testing and monitoring plan or demonstrate to the Director that no amendment to the testing and monitoring plan is needed. Any amendments to the testing and monitoring plan must be approved by the Director, must be incorporated into the permit, and are subject to the permit modification requirements at §§ 144.39 or 144.41 of this chapter, as appropriate. Amended plans or demonstrations shall be submitted to the Director as follows:</p> <p>(1) Within one year of an area of review reevaluation;</p> <p>(2) Following any significant changes to the facility, such as addition of monitoring wells or newly permitted injection wells within the area of review, on a schedule determined by the Director; or</p> <p>(3) When required by the Director.</p> | Section 6A.2.7 |
| <p>(k) A quality assurance and surveillance plan for all testing and monitoring requirements.</p> | Section 6A.5 |

| | |
|--|--------------|
| <p>§ 146.91 Reporting requirements. The owner or operator must, at a minimum, provide, as specified in paragraph (e) of this section, the following reports to the Director, for each permitted Class VI well:</p> <p>(a) Semi-annual reports containing:</p> <ol style="list-style-type: none"> (1) Any changes to the physical, chemical, and other relevant characteristics of the carbon dioxide stream from the proposed operating data; (2) Monthly average, maximum, and minimum values for injection pressure, flow rate and volume, and annular pressure; (3) A description of any event that exceeds operating parameters for annulus pressure or injection pressure specified in the permit; (4) A description of any event which triggers a shut-off device required pursuant to § 146.88(e) and the response taken; (5) The monthly volume and/or mass of the carbon dioxide stream injected over the reporting period and the volume injected cumulatively over the life of the project; (6) Monthly annulus fluid volume added; and (7) The results of monitoring prescribed under § 146.90. | Section 6A.6 |
| <p>(b) Report, within 30 days, the results of:</p> <ol style="list-style-type: none"> (1) Periodic tests of mechanical integrity; (2) Any well workover; and, (3) Any other test of the injection well conducted by the permittee if required by the Director. | Section 6A.6 |
| <p>(c) Report, within 24 hours:</p> <ol style="list-style-type: none"> (1) Any evidence that the injected carbon dioxide stream or associated pressure front may cause an endangerment to a USDW; (2) Any noncompliance with a permit condition, or malfunction of the injection system, which may cause fluid migration into or between USDWs; (3) Any triggering of a shut-off system (<i>i.e.</i>, down-hole or at the surface); (4) Any failure to maintain mechanical integrity; or. (5) Pursuant to compliance with the requirement at § 146.90(h) for surface air/soil gas monitoring or other monitoring technologies, if required by the Director, any release of carbon dioxide to the atmosphere or biosphere. | Section 6A.6 |
| <p>(d) Owners or operators must notify the Director in writing 30 days in advance of:</p> <ol style="list-style-type: none"> (1) Any planned well workover; (2) Any planned stimulation activities, other than stimulation for formation testing conducted under § 146.82; and (3) Any other planned test of the injection well conducted by the permittee. | Section 6A.6 |
| <p>(e) Regardless of whether a State has primary enforcement responsibility, owners or operators must submit all required reports, submittals, and notifications under subpart H of this part to EPA in an electronic format approved by EPA.</p> | Section 6A.6 |
| <p>(f) Records shall be retained by the owner or operator as follows:</p> <ol style="list-style-type: none"> (1) All data collected under § 146.82 for Class VI permit applications shall be retained throughout the life of the geologic sequestration project and for 10 years following site closure. (2) Data on the nature and composition of all injected fluids collected pursuant to § 146.90(a) shall be retained until 10 years after site closure. The Director may require the owner or operator to deliver the records to the Director at the conclusion of the retention period. (3) Monitoring data collected pursuant to § 146.90(b) through (i) shall be retained for 10 years after it is collected. (4) Well plugging reports, post-injection site care data, including, if appropriate, data and information used to develop the demonstration of the alternative post-injection site care timeframe, and the site closure report collected pursuant to requirements at §§ 146.93(f) and (h) shall be retained for 10 years following site closure. (5) The Director has authority to require the owner or operator to retain any records required in this subpart for longer than 10 years after site closure. | Section 6A.6 |

| | |
|--|---|
| <p>§ 146.92 Injection well plugging. (a) Prior to the well plugging, the owner or operator must flush each Class VI injection well with a buffer fluid, determine bottomhole reservoir pressure, and perform a final external mechanical integrity test.</p> | <p>Section 8A.1.2</p> |
| <p>(b) <i>Well plugging plan.</i> The owner or operator of a Class VI well must prepare, maintain, and comply with a plan that is acceptable to the Director. The requirement to maintain and implement an approved plan is directly enforceable regardless of whether the requirement is a condition of the permit. The well plugging plan must be submitted as part of the permit application and must include the following information:</p> <ol style="list-style-type: none"> (1) Appropriate tests or measures for determining bottomhole reservoir pressure; (2) Appropriate testing methods to ensure external mechanical integrity as specified in § 146.89; (3) The type and number of plugs to be used; (4) The placement of each plug, including the elevation of the top and bottom of each plug; (5) The type, grade, and quantity of material to be used in plugging. The material must be compatible with the carbon dioxide stream; and (6) The method of placement of the plugs. | <p>Section 8A.1.4</p> <p>Section 8A.1.4.1 8A.1.4.3 8A.1.4.4</p> |
| <p>(c) <i>Notice of intent to plug.</i> The owner or operator must notify the Director in writing pursuant to § 146.91(e), at least 60 days before plugging of a well. At this time, if any changes have been made to the original well plugging plan, the owner or operator must also provide the revised well plugging plan. The Director may allow for a shorter notice period. Any amendments to the injection well plugging plan must be approved by the Director, must be incorporated into the permit, and are subject to the permit modification requirements at §§ 144.39 or 144.41 of this chapter, as appropriate.</p> | <p>Section 8A.1.4.1</p> |
| <p>(d) <i>Plugging report.</i> Within 60 days after plugging, the owner or operator must submit, pursuant to § 146.91(e), a plugging report to the Director. The report must be certified as accurate by the owner or operator and by the person who performed the plugging operation (if other than the owner or operator.) The owner or operator shall retain the well plugging report for 10 years following site closure.</p> | <p>Section 8A.1.4.3 8A.1.4.4</p> |

| | |
|---|--|
| <p>§ 146.93 Post-injection site care and site closure.</p> <p>(a) The owner or operator of a Class VI well must prepare, maintain, and comply with a plan for post-injection site care and site closure that meets the requirements of paragraph (a)(2) of this section and is acceptable to the Director. The requirement to maintain and implement an approved plan is directly enforceable regardless of whether the requirement is a condition of the permit.</p> <p>(1) The owner or operator must submit the post-injection site care and site closure plan as a part of the permit application to be approved by the Director.</p> | <p>Section 9</p> <p>Section 9</p> |
| <p>(2) The post-injection site care and site closure plan must include the following information:</p> <ul style="list-style-type: none"> (i) The pressure differential between pre-injection and predicted post-injection pressures in the injection zone(s); (ii) The predicted position of the carbon dioxide plume and associated pressure front at site closure as demonstrated in the area of review evaluation required under § 146.84(c)(1); (iii) A description of post-injection monitoring location, methods, and proposed frequency; (iv) A proposed schedule for submitting post-injection site care monitoring results to the Director pursuant to § 146.91(e); and, (v) The duration of the post-injection site care timeframe and, if approved by the Director, the demonstration of the alternative post-injection site care timeframe that ensures non-endangerment of USDWs. | <p>Section 9.1.1</p> <p>Section 9.1.2</p> <p>Section 9.1.1</p> <p>Section 9.1.2</p> <p>Section 9.1.3</p> |
| <p>(3) Upon cessation of injection, owners or operators of Class VI wells must either submit an amended post-injection site care and site closure plan or demonstrate to the Director through monitoring data and modeling results that no amendment to the plan is needed. Any amendments to the post-injection site care and site closure plan must be approved by the Director, be incorporated into the permit, and are subject to the permit modification requirements at §§ 144.39 or 144.41 of this chapter, as appropriate.</p> | <p>Section 9.1.1</p> <p>Section 9.1.2</p> |
| <p>(4) At any time during the life of the geologic sequestration project, the owner or operator may modify and resubmit the post-injection site care and site closure plan for the Director’s approval within 30 days of such change.</p> | <p>As noted</p> |
| <p>(b) The owner or operator shall monitor the site following the cessation of injection to show the position of the carbon dioxide plume and pressure front and demonstrate that USDWs are not being endangered.</p> <p>(1) Following the cessation of injection, the owner or operator shall continue to conduct monitoring as specified in the Director-approved post-injection site care and site closure plan for at least 50 years or for the duration of the alternative timeframe approved by the Director pursuant to requirements in paragraph (c) of this section, unless he/she makes a demonstration under (b)(2) of this section. The monitoring must continue until the geologic sequestration project no longer poses an endangerment to USDWs and the demonstration under (b)(2) of this section is submitted and approved by the Director.</p> <p>(2) If the owner or operator can demonstrate to the satisfaction of the Director before 50 years or prior to the end of the approved alternative timeframe based on monitoring and other site-specific data, that the geologic sequestration project no longer poses an endangerment to USDWs, the Director may approve an amendment to the post-injection site care and site closure plan to reduce the frequency of monitoring or may authorize site closure before the end of the 50-year period or prior to the end of the approved alternative timeframe, where he or she has substantial evidence that the geologic sequestration project no longer poses a risk of endangerment to USDWs.</p> <p>(3) Prior to authorization for site closure, the owner or operator must submit to the Director for review and approval a demonstration, based on monitoring and other site-specific data, that no additional monitoring is needed to ensure that the geologic sequestration project does not pose an endangerment to USDWs.</p> <p>(4) If the demonstration in paragraph (b)(3) of this section cannot be made (<i>i.e.</i>, additional monitoring is needed to ensure that the geologic sequestration project does not pose an endangerment to USDWs) at the end of the 50-year period or at the end of the approved alternative timeframe, or if the Director does not approve the demonstration, the owner or operator must submit to the Director a plan to continue post-injection site care until a demonstration can be made and approved by the Director.</p> | <p>Section 9.1.1</p> <p>Section 9.1.3</p> <p>Section 9.1.3</p> <p>Section 9.1.3</p> <p>Section 9.1.3</p> |

§ 146.93 Post-injection site care and site closure. (cont'd)

Section 9.1.3

(c) *Demonstration of alternative post-injection site care timeframe.* At the Director's discretion, the Director may approve, in consultation with EPA, an alternative post-injection site care timeframe other than the 50 year default, if an owner or operator can demonstrate during the permitting process that an alternative post-injection site care timeframe is appropriate and ensures non-endangerment of USDWs. The demonstration must be based on significant, site-specific data and information including all data and information collected pursuant to §§ 146.82 and 146.83, and must contain substantial evidence that the geologic sequestration project will no longer pose a risk of endangerment to USDWs at the end of the alternative post-injection site care timeframe.

(1) A demonstration of an alternative post-injection site care timeframe must include consideration and documentation of:

- (i) The results of computational modeling performed pursuant to delineation of the area of review under § 146.84;
- (ii) The predicted timeframe for pressure decline within the injection zone, and any other zones, such that formation fluids may not be forced into any USDWs; and/or the timeframe for pressure decline to pre-injection pressures; (iii) The predicted rate of carbon dioxide plume migration within the injection zone, and the predicted timeframe for the cessation of migration;
- (iii) A description of the site-specific processes that will result in carbon dioxide trapping including immobilization by capillary trapping, dissolution, and mineralization at the site;
- (iv) The predicted rate of carbon dioxide trapping in the immobile capillary phase, dissolved phase, and/or mineral phase;
- (v) The results of laboratory analyses, research studies, and/or field or site-specific studies to verify the information required in paragraphs (iv) and (v) of this section;
- (vi) A characterization of the confining zone(s) including a demonstration that it is free of transmissive faults, fractures, and micro-fractures and of appropriate thickness, permeability, and integrity to impede fluid (e.g., carbon dioxide, formation fluids) movement;
- (vii) The presence of potential conduits for fluid movement including planned injection wells and project monitoring wells associated with the proposed geologic sequestration project or any other projects in proximity to the predicted/modeled, final extent of the carbon dioxide plume and area of elevated pressure;
- (viii) A description of the well construction and an assessment of the quality of plugs of all abandoned wells within the area of review;
- (ix) The distance between the injection zone and the nearest USDWs above and/or below the injection zone; and
- (x) Any additional site-specific factors required by the Director.

(2) Information submitted to support the demonstration in paragraph (c)(1) of this section must meet the following criteria:

- (i) All analyses and tests performed to support the demonstration must be accurate, reproducible, and performed in accordance with the established quality assurance standards;
- (ii) Estimation techniques must be appropriate and EPA-certified test protocols must be used where available; (iii) Predictive models must be appropriate and tailored to the site conditions, composition of the carbon dioxide stream and injection and site conditions over the life of the geologic sequestration project;
- (iii) Predictive models must be calibrated using existing information (e.g., at Class I, Class II, or Class V experimental technology well sites) where sufficient data are available;
- (iv) Reasonably conservative values and modeling assumptions must be used and disclosed to the Director whenever values are estimated on the basis of known, historical information instead of site-specific measurements;
- (v) An analysis must be performed to identify and assess aspects of the alternative post-injection site care timeframe demonstration that contribute significantly to uncertainty. The owner or operator must conduct sensitivity analyses to determine the effect that significant uncertainty may contribute to the modeling demonstration.
- (vi) An approved quality assurance and quality control plan must address all aspects of the demonstration; and,
- (vii) Any additional criteria required by the Director.
- (viii)

| | |
|---|---------------|
| <p>§ 146.93 Post-injection site care and site closure. (cont'd) (d) <i>Notice of intent for site closure.</i> The owner or operator must notify the Director in writing at least 120 days before site closure. At this time, if any changes have been made to the original post-injection site care and site closure plan, the owner or operator must also provide the revised plan. The Director may allow for a shorter notice period.</p> | Section 9.1.4 |
| <p>(e) After the Director has authorized site closure, the owner or operator must plug all monitoring wells in a manner which will not allow movement of injection or formation fluids that endangers a USDW.</p> | Section 9.1.4 |
| <p>(f) The owner or operator must submit a site closure report to the Director within 90 days of site closure, which must thereafter be retained at a location designated by the Director for 10 years. The report must include: (1) Documentation of appropriate injection and monitoring well plugging as specified in § 146.92 and paragraph (e) of this section. The owner or operator must provide a copy of a survey plat which has been submitted to the local zoning authority designated by the Director. The plat must indicate the location of the injection well relative to permanently surveyed benchmarks. The owner or operator must also submit a copy of the plat to the Regional Administrator of the appropriate EPA Regional Office; (2) Documentation of appropriate notification and information to such State, local and Tribal authorities that have authority over drilling activities to enable such State, local, and Tribal authorities to impose appropriate conditions on subsequent drilling activities that may penetrate the injection and confining zone(s); and (3) Records reflecting the nature, composition, and volume of the carbon dioxide stream.</p> | Section 9.1.4 |
| <p>(g) Each owner or operator of a Class VI injection well must record a notation on the deed to the facility property or any other document that is normally examined during title search that will in perpetuity provide any potential purchaser of the property the following information: (1) The fact that land has been used to sequester carbon dioxide; (2) The name of the State agency, local authority, and/or Tribe with which the survey plat was filed, as well as the address of the Environmental Protection Agency Regional Office to which it was submitted; and (3) The volume of fluid injected, the injection zone or zones into which it was injected, and the period over which injection occurred.</p> | Section 9.1.4 |
| <p>(h) The owner or operator must retain for 10 years following site closure, records collected during the post-injection site care period. The owner or operator must deliver the records to the Director at the conclusion of the retention period, and the records must thereafter be retained at a location designated by the Director for that purpose.</p> | Section 9.1.4 |

| | |
|--|------------------------------------|
| <p>§ 146.94 Emergency and remedial response.</p> <p>(a) As part of the permit application, the owner or operator must provide the Director with an emergency and remedial response plan that describes actions the owner or operator must take to address movement of the injection or formation fluids that may cause an endangerment to a USDW during construction, operation, and post-injection site care periods. The requirement to maintain and implement an approved plan is directly enforceable regardless of whether the requirement is a condition of the permit.</p> | <p>Section 6A.4 Appendix H</p> |
| <p>(b) If the owner or operator obtains evidence that the injected carbon dioxide stream and associated pressure front may cause an endangerment to a USDW, the owner or operator must:</p> <ol style="list-style-type: none"> (1) Immediately cease injection; (2) Take all steps reasonably necessary to identify and characterize any release; (3) Notify the Director within 24 hours; and (4) Implement the emergency and remedial response plan approved by the Director. | <p>Appendix H</p> |
| <p>(c) The Director may allow the operator to resume injection prior to remediation if the owner or operator demonstrates that the injection operation will not endanger USDWs.</p> | <p>Agency action</p> |
| <p>(d) The owner or operator shall periodically review the emergency and remedial response plan developed under paragraph (a) of this section. In no case shall the owner or operator review the emergency and remedial response plan less often than once every five years. Based on this review, the owner or operator shall submit an amended emergency and remedial response plan or demonstrate to the Director that no amendment to the emergency and remedial response plan is needed. Any amendments to the emergency and remedial response plan must be approved by the Director, must be incorporated into the permit, and are subject to the permit modification requirements at §§ 144.39 or 144.41 of this chapter, as appropriate. Amended plans or demonstrations shall be submitted to the Director as follows:</p> <ol style="list-style-type: none"> (1) Within one year of an area of review reevaluation; (2) Following any significant changes to the facility, such as addition of injection or monitoring wells, on a schedule determined by the Director; or (3) When required by the Director. | <p>Appendix H</p> |

List of Abbreviations Used in this Application

| | |
|-------------------|-------------------------------------|
| 2D | two-dimensional |
| 3D | three-dimensional |
| ADM | Archer Daniels Midland |
| aka | also known as |
| AoR | area of review |
| API | American Petroleum Institute |
| bbls | barrels |
| BHA | bottom hole assembly |
| BHCT | bottom hole circulating temperature |
| BHST | bottom hole static temperature |
| BOD | basis of design |
| BOP | blow out preventer |
| bpm | barrels per minute |
| B-T gauge | Bourdon-tube gauge |
| BTC | buttress thread & coupling |
| BTU | British thermal unit |
| C | Celsius |
| CaCl ₂ | calcium chloride |
| CaCO ₃ | calcium carbonate |
| CBL | cement bond log |
| CCS | carbon capture and sequestration |
| cf | cubic feet |
| cf/sk | cubic feet per sack |
| CFR | Code of Federal Regulations |
| cm | centimeter(s) |
| CO ₂ | carbon dioxide |
| cp | centipoises (viscosity unit) |
| csg | casing |
| cu | capture units |
| D&CWOP | Drill and complete well on paper |
| e.g. | for example |
| EMR | electronic memory recorder |
| EOR | enhanced oil recovery |
| EOT | end of tubing |
| est. | estimate |
| etc. | et cetera |
| EUE | external upset end |
| F | Fahrenheit |
| FIT | formation integrity test |
| FEED | front end engineering design |
| FOT | fall-off test |
| FS | full scale |
| ft | foot or feet |
| ft/hr | feet per hour |
| ft/min | feet per minute |
| gal/sk | gallons per sack |
| g/L | grams per liter |

List of Abbreviations Used in this Application

| | |
|------------------|--|
| gpm | gallons per minute |
| GR | gamma ray |
| H ₂ S | hydrogen sulfide |
| HAZOP | Hazard and Operability Study |
| hp | horsepower |
| hr(s) | hour(s) |
| IBDP | Illinois Basin – Decatur Project |
| IBOP | inside blowout preventor |
| ID | inside diameter |
| IEPA | Illinois Environmental Protection Agency |
| IL-ICCS | Illinois – Industrial Carbon Capture and Sequestration |
| in. | inch(es) |
| ISGS | Illinois State Geological Survey |
| KCl | potassium chloride |
| km | kilometer(s) |
| L (l) | liter(s) |
| Lb (lbs) | pound (pounds) |
| Lb/ft (lbm/ft) | pounds per foot |
| Lb/sk | pounds per sack |
| LCM | lost circulation material |
| LTC | long thread & coupling |
| M (m) | meter(s) |
| m/hr | meters per hour |
| MASIP | maximum allowable surface injection pressure |
| MDT | modular dynamic tester |
| mD | millidarcy (millidarcies) |
| MD | measured depth |
| meV | milli electronvolts |
| mg/L | milligrams per liter |
| MFC | multi-finger caliper |
| MGSC | Midwest Geologic Sequestration Consortium |
| MI | move in |
| mi. | miles |
| mL | milliliter |
| mmscf | million standard cubic feet |
| MO | move out |
| Mol. | mole |
| MOSDAX | modular subsurface data acquisition system |
| μPa | microPascal |
| MPa | MegaPascal |
| MSL | mean sea level |
| MT | metric tonnes |
| MT/day | metric tonnes per day |
| MVA | monitoring, verification, and accounting |
| N ₂ | nitrogen (atmospheric) |
| NaCl | sodium chloride |
| N/A | not applicable |

List of Abbreviations Used in this Application

| | |
|----------------|---|
| ND | nipple down |
| NPDES | National Pollution Discharge Elimination System |
| NRC | Nuclear Regulatory Commission |
| NU | nipple up |
| O ₂ | oxygen (atmospheric) |
| OD | outside diameter |
| Pa | Pascal (pressure unit) |
| P&A | plugging and abandonment |
| P&ID | Piping & Instrument Diagram |
| PBTD | Plug back total depth |
| PCSD | Process Control Strategy Diagram |
| PFD | process flow diagram |
| PFO | pressure fall off |
| PISC | post-injection site care |
| POOH | pull out of hole |
| Poz | pozzolan |
| ppg | pounds per gallon |
| ppb | parts per billion |
| ppm | parts per million |
| ppmv | parts per million by volume |
| ppmwt | parts per million by weight |
| psi | pounds per square inch |
| psia | pounds per square inch atmospheric |
| psig | pounds per square inch gauge |
| psi/ft | pounds per square inch per foot |
| PV | plastic viscosity |
| QA | quality assurance |
| QHSE | quality, health, safety, and environment |
| Qty | quantity |
| RCC | Richland Community College |
| RD | rig down |
| RU | rig up |
| RST | reservoir saturation tool |
| RSTPro | trademark reservoir saturation tool |
| S (sec) | seconds |
| SCS | Schlumberger Carbon Services |
| SCMT | slim cement mapping tool |
| sk(s) | sack(s) |
| SIP | surface injection pressure |
| SP | spontaneous potential |
| SPF | slots per foot |
| SRPG | surface-readout pressure gauge |
| SRTs | step rate tests |
| SS | stainless steel |
| STC | short thread & coupling |
| TBD | to be determined |
| tbg | tubing |

List of Abbreviations Used in this Application

| | |
|--------|---|
| TD | total depth |
| TDS | total dissolved solids |
| TEC | tri-ethylene glycol |
| TIH | trip in hole |
| TIW | Texas Iron Works (pressure valve) |
| TOH | trip out of hole |
| TVD | true vertical depth |
| UIC | underground injection control |
| US DOE | United States Department of Energy |
| USEPA | United States Environmental Protection Agency |
| USDW | underground source of drinking water |
| USGS | United States Geological Survey |
| USIT | ultrasonic imaging tool |
| V (v) | volt |
| VFD | variable frequency drive |
| VSP | vertical seismic profile |
| WFL | water flow log |
| WOC | wait on cement |

| | | | | | | | | | | | | | | | | |
|---|---|--|---|---|-----|-----|-----|-------|---------|--|------|-----------|------|--|--|--|
| United States Environmental Protection Agency Underground Injection Control Permit Application <i>(Collected under the authority of the Safe Drinking Water Act, Sections 1421, 1422, 40 CFR 144)</i> | | I. EPA ID Number ILD984791459 | | | | | | | | | | | | | | |
| | | | T/A | C | | | | | | | | | | | | |
| Read Attached Instructions Before Starting For Official Use Only | | | | | | | | | | | | | | | | |
| Application approved mo day year | Date received mo day year | Permit Number | Well ID | FINDS Number | | | | | | | | | | | | |
| II. Owner Name and Address | | III. Operator Name and Address | | | | | | | | | | | | | | |
| Owner Name Archer Daniels Midland Company | | Owner Name Archer Daniels Midland Company | | | | | | | | | | | | | | |
| Street Address 4666 Faries Parkway | | Phone Number (217) 451-6330 | Street Address 4666 Faries Parkway | | | | | | | | | | | | | |
| City Decatur | | State IL | ZIP CODE 62526 | City Decatur | | | | | | | | | | | | |
| State IL | | ZIP CODE 62526 | | | | | | | | | | | | | | |
| IV. Commercial Facility | V. Ownership | VI. Legal Contact | VII. SIC Codes | | | | | | | | | | | | | |
| <input type="checkbox"/> Yes <input type="checkbox"/> No | <input checked="" type="checkbox"/> Private <input type="checkbox"/> Federal <input type="checkbox"/> Other | <input checked="" type="checkbox"/> Owner <input type="checkbox"/> Operator | 2046, 2869, 2075, 2076 | | | | | | | | | | | | | |
| VIII. Well Status (Mark "x") | | | | | | | | | | | | | | | | |
| <input type="checkbox"/> A. Operating | Date Started mo day year | <input type="checkbox"/> B. Modification/Conversion | <input checked="" type="checkbox"/> C. Proposed | | | | | | | | | | | | | |
| IX. Type of Permit Requested (Mark "x" and specify if required) | | | | | | | | | | | | | | | | |
| <input checked="" type="checkbox"/> A. Individual | <input type="checkbox"/> B. Area | Number of Existing Wells 0 | Number of Proposed Wells 1 | Name(s) of field(s) or project(s) Illinois Industrial Carbon Capture & Storage (IL-ICCS) | | | | | | | | | | | | |
| X. Class and Type of Well (see reverse) | | | | | | | | | | | | | | | | |
| A. Class(es) (enter code(s)) | B. Type(s) (enter code(s)) | C. If class is "other" or type is code 'x,' explain Geologic Sequestration | | D. Number of wells per type (if area permit) | | | | | | | | | | | | |
| Other (Class VI) | X | | | 1 - injection well 1 - verification (monitoring) well 1 - geophysical (monitoring) well | | | | | | | | | | | | |
| XI. Location of Well(s) or Approximate Center of Field or Project | | | | XII. Indian Lands (Mark 'x') | | | | | | | | | | | | |
| Latitude | | Longitude | | Township and Range | | | | | | | | | | | | <input type="checkbox"/> Yes <input checked="" type="checkbox"/> No |
| Deg | Min | Sec | Deg | Min | Sec | Sec | Twp | Range | 1/4 Sec | Feet From | Line | Feet From | Line | | | |
| 39 | 53 | 08 | 89 | 53 | 19 | 32 | 17N | 3E | NW | 2601 | N | 2511 | W | | | |
| XIII. Attachments | | | | | | | | | | | | | | | | |
| (Complete the following questions on a separate sheet(s) and number accordingly; see instructions) For Classes I, II, III, (and other classes) complete and submit on a separate sheet(s) Attachments A-U (pp 2-6) as appropriate. Attach maps where required. List attachments by letter which are applicable and are included with your application. | | | | | | | | | | | | | | | | |
| XIV. Certification | | | | | | | | | | | | | | | | |
| I certify under the penalty of law that I have personally examined and am familiar with the information submitted in this document and all attachments and that, based on my inquiry of those individuals immediately responsible for obtaining the information, I believe that the information is true, accurate, and complete. I am aware that there are significant penalties for submitting false information, including the possibility of fine and imprisonment. (Ref. 40 CFR 144.32) | | | | | | | | | | | | | | | | |
| A. Name and Title (Type or Print) Mark Burau, Decatur Corn Plant Manager | | | | | | | | | | B. Phone No. (Area Code and No.) (217) 451-6330 | | | | | | |
| C. Signature | | | | | | | | | | D. Date Signed 7/25/2011 | | | | | | |



United States Environmental Protection Agency
Washington, DC 20460

PLUGGING AND ABANDONMENT PLAN

| | |
|--|--|
| Name and Address of Facility Archer Daniels Midland Company 4666 Faries Parkway, Decatur IL 62526 | Name and Address of Owner/Operator Archer Daniels Midland Company 4666 Faries Parkway, Decatur IL 62526 |
|--|--|

| | | | |
|---|--------------------|--|--------------------------|
| Locate Well and Outline Unit on Section Plat - 640 Acres | State IL | County Macon | Permit Number |
| Surface Location Description SE 1/4 of SE 1/4 of SE 1/4 of NW 1/4 of Section 32 Township 17N Range 3E | | | |
| Locate well in two directions from nearest lines of quarter section and drilling unit Surface Location 26 ft. from (N/S) N Line of quarter section and 25 ft. from (E/W) W Line of quarter section. | | | |
| TYPE OF AUTHORIZATION <input checked="" type="checkbox"/> Individual Permit <input type="checkbox"/> Area Permit <input type="checkbox"/> Rule Number of Wells 1 Lease Name NA | | WELL ACTIVITY <input type="checkbox"/> CLASS I <input type="checkbox"/> CLASS II <input type="checkbox"/> Brine Disposal <input type="checkbox"/> Enhanced Recovery <input type="checkbox"/> Hydrocarbon Storage <input type="checkbox"/> CLASS III Well Number Class VI (GS) / CCS #2 | |

| CASING AND TUBING RECORD AFTER PLUGGING | | | | |
|---|------------|------------------------|-------------------------|-----------|
| SIZE | WT (LB/FT) | TO BE PUT IN WELL (FT) | TO BE LEFT IN WELL (FT) | HOLE SIZE |
| 20 | 94 | 350 | 350 | 26 |
| 13 3/8 | 61 | 5300 | 5300 | 17.5 |
| 9.625 | 40 | 5000 | 5000 | 12.25 |
| 9.625 | 47 | 2250 | 2250 | 12.25 |

| METHOD OF EMPLACEMENT OF CEMENT PLUGS |
|---|
| <input checked="" type="checkbox"/> The Balance Method <input type="checkbox"/> The Dump Baller Method <input type="checkbox"/> The Two-Plug Method <input type="checkbox"/> Other |

| CEMENTING TO PLUG AND ABANDON DATA: | | | | | | | |
|--|----------|----------|----------|----------|----------|------------|---------|
| | PLUG #1 | PLUG #2 | PLUG #3 | PLUG #4 | PLUG #5 | PLUG #6 | PLUG #7 |
| Size of Hole or Pipe in which Plug Will Be Placed (inches) | 8.681 | 8.681 | 8.681 | 8.681 | 8.835 | 8.835 | 8.835 |
| Depth to Bottom of Tubing or Drill Pipe (ft) | NA | | | | | plgs 6-13 | plug 14 |
| Sacks of Cement To Be Used (each plug) | 204 | 185 | 185 | 185 | 191 | 191 | 191 |
| Slurry Volume To Be Pumped (cu. ft.) | 226 | 205 | 205 | 205 | 212 | 212 | 212 |
| Calculated Top of Plug (ft.) | 6500 | 6000 | 5500 | 5000 | 4500 | 500 ft int | 0 |
| Measured Top of Plug (if tagged ft.) | NA | | | | | | |
| Slurry Wt. (Lb./Gal.) | 15.9 | 15.9 | 15.9 | 15.9 | 15.9 | 15.9 | 15.9 |
| Type Cement or Other Material (Class III) | Ev-Crete | Ev-Crete | Ev-Crete | Ev-Crete | Ev-Crete | Ev-Crete | Class H |

| LIST ALL OPEN HOLE AND/OR PERFORATED INTERVALS AND INTERVALS WHERE CASING WILL BE VARIED (if any) | | | |
|---|------|------|----|
| From | To | From | To |
| 6700 | 7050 | | |
| | | | |
| | | | |

Estimated Cost to Plug Wells
\$421,000

Certification

I certify under the penalty of law that I have personally examined and am familiar with the information submitted in this document and all attachments and that, based on my inquiry of those individuals immediately responsible for obtaining the information, I believe that the information is true, accurate, and complete. I am aware that there are significant penalties for submitting false information, including the possibility of fine and imprisonment. (Ref. 40 CFR 144.32)

| | | |
|--|----------------------|---------------------------------|
| Name and Official Title (Please type or print) Mark Bureau, Decatur Corn Plant Manager | Signature | Date Signed 7/25/2011 |
|--|----------------------|---------------------------------|



United States Environmental Protection Agency
Washington, DC 20460

PLUGGING AND ABANDONMENT PLAN

| | |
|---|---|
| Name and Address of Facility Archer Daniels Midland Company 4666 Faries Parkway, Decatur, IL 62526 | Name and Address of Owner/Operator Archer Daniels Midland Company 4666 Faries Parkway, Decatur, IL 62526 |
|---|---|

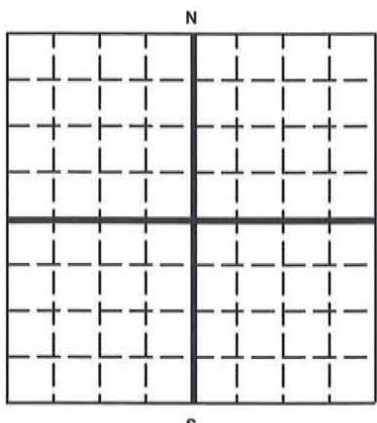
| | | | |
|--|---------------------------------------|--|------------------------------------|
| Locate Well and Outline Unit on Section Plat - 640 Acres  | State <input type="text" value="IL"/> | County <input type="text" value="Macon"/> | Permit Number <input type="text"/> |
| Surface Location Description <input type="text"/> 1/4 of <input type="text"/> 1/4 of <input type="text"/> 1/4 of <input type="text"/> 1/4 of Section <input type="text"/> Township <input type="text"/> Range <input type="text"/> | | | |
| Locate well in two directions from nearest lines of quarter section and drilling unit Surface Location <input type="text"/> ft. frm (N/S) <input type="text"/> Line of quarter section and <input type="text"/> ft. from (E/W) <input type="text"/> Line of quarter section. | | | |
| TYPE OF AUTHORIZATION <input type="checkbox"/> Individual Permit <input type="checkbox"/> Area Permit <input type="checkbox"/> Rule Number of Wells <input type="text"/> | | WELL ACTIVITY <input type="checkbox"/> CLASS I <input type="checkbox"/> CLASS II <input type="checkbox"/> Brine Disposal <input type="checkbox"/> Enhanced Recovery <input type="checkbox"/> Hydrocarbon Storage <input type="checkbox"/> CLASS III | |
| Lease Name <input type="text"/> | | Well Number <input type="text"/> | |

| CASING AND TUBING RECORD AFTER PLUGGING | | | | | METHOD OF EMPLACEMENT OF CEMENT PLUGS | |
|---|------------|------------------------|-------------------------|-----------|---|--|
| SIZE | WT (LB/FT) | TO BE PUT IN WELL (FT) | TO BE LEFT IN WELL (FT) | HOLE SIZE | | |
| 13-3/8 | 54.5 | 350 | 350 | 17-1/2 | <input type="checkbox"/> The Balance Method | |
| 9-5/8 | 40 | 5300 | 5300 | 12-1/4 | <input type="checkbox"/> The Dump Bailer Method | |
| 5-1/2 | 17 | 7250 | 7250 | 8-1/2 | <input type="checkbox"/> The Two-Plug Method | |
| | | | | | <input type="checkbox"/> Other | |

| CEMENTING TO PLUG AND ABANDON DATA: | | | | | | | |
|--|----------|----------|----------|----------|----------|----------|---------|
| | PLUG #1 | PLUG #2 | PLUG #3 | PLUG #4 | PLUG #5 | PLUG #6 | PLUG #7 |
| Size of Hole or Pipe in which Plug Will Be Placed (inches) | 4.892 | 4.892 | 4.892 | 4.892 | 4.892 | 4.892 | 4.892 |
| Depth to Bottom of Tubing or Drill Pipe (ft) | | | | | | plgs6-13 | plug 14 |
| Sacks of Cement To Be Used (each plug) | 65 | 59 | 59 | 59 | 59 | 59 | 59 |
| Slurry Volume To Be Pumped (cu. ft.) | 72 | 65 | 65 | 65 | 65 | 65 | 65 |
| Calculated Top of Plug (ft.) | 6500 | 6000 | 5500 | 5000 | 4500 | 4K to500 | 0 |
| Measured Top of Plug (if tagged ft.) | | | | | | | |
| Slurry Wt. (Lb./Gal.) | 15.9 | 15.9 | 15.9 | 15.9 | 15.9 | 15.9 | 15.9 |
| Type Cement or Other Material (Class III) | Ev-crete | Ev-crete | Ev-crete | Ev-crete | Ev-crete | Class H | Class H |

| LIST ALL OPEN HOLE AND/OR PERFORATED INTERVALS AND INTERVALS WHERE CASING WILL BE VARIED (if any) | | | |
|---|----------------------------------|------|----|
| From | To | From | To |
| 5700-5702 | 6910-6912 | | |
| 6060-6062 | 7025-7027 | | |
| 6540-6542 | perf intvls are prelim estimates | | |
| 6805-6807 | (approx 6 zones in Mt Simon) | | |

Estimated Cost to Plug Wells
\$317,000

Certification

I certify under the penalty of law that I have personally examined and am familiar with the information submitted in this document and all attachments and that, based on my inquiry of those individuals immediately responsible for obtaining the information, I believe that the information is true, accurate, and complete. I am aware that there are significant penalties for submitting false information, including the possibility of fine and imprisonment. (Ref. 40 CFR 144.32)

| | | |
|--|---|--------------------------|
| Name and Official Title (Please type or print) Mark Burau, Decatur Corn Plant Manager | Signature  | Date Signed 7/25/2011 |
|--|---|--------------------------|

SECTION 2 - HYDROGEOLOGIC INFORMATION

2.1 Elevation of Land Surface at Well Location.

The surface elevation at the proposed carbon sequestration site is approximately 675 feet above mean sea level (MSL), as referenced from the Forsyth, Illinois, United States Geological Survey (USGS) 7.5-minute topographic quadrangle map.

2.2 Faults, Known or Suspected Within the Area of Review.

Regional mapping (Nelson, 1995), and 2D and 3D seismic surveys in the vicinity of the proposed site do not indicate the presence of faulting at the injection site (Leetaru, 2011). There are no regional faults or fractures mapped within a 25-mile radius of the proposed site (Figure 2-1). Seismic reflection data were acquired near the site to identify the presence of faults and geologic structures in the vicinity of the proposed well site. Acquired 3D seismic reflection data at the Illinois Basin Decatur Project (IBDP) site showed no evidence of faulting through either the Mt. Simon Sandstone or the Eau Claire Formation intervals. In addition, higher resolution 3D VSP was acquired at the IBDP injection site. This higher resolution data set did not show any breaks in continuity that are associated with faults. Interpretations of the seismic reflection data suggest that no faults or fractures occur at the proposed injection site (Figures 2-2 through 2-4). Newly acquired 3D seismic data has already been acquired at the proposed ICCS site and is currently being processed.

2.2.1 Seismic History and Risk

Since 1973, two earthquakes have been recorded within 100 km of the proposed injection site: a magnitude 3.0 quake on April 24, 1990 in Coles County approximately 41 miles to the southeast, and a magnitude 3.2 quake on January 29, 1993 in Fayette County approximately 58 miles to the south-southwest (http://earthquake.usgs.gov/earthquakes/eqarchives/epic/epic_circ.php, USGS Earthquake Search, as of March 17, 2011).

The relative seismic risk of the Decatur location is considered minimal. The probability of an earthquake of magnitude 5.0 or greater within 50 years and within 50 km is less than 1% (USGS 2009 PSHA model for Decatur, Illinois, <https://geohazards.usgs.gov/eqprob/2009/>). There exists a 2% probability that the Peak Ground Acceleration due to seismic activity will exceed 10% G within 50 years (<http://earthquake.usgs.gov/earthquakes/states/illinois/hazards.php>). Thus, the risk of seismic activity breaching the integrity of the well or the injection formation is considered minimal.

Source:

Leetaru, H., 2011. Personal communication, Illinois State Geological Survey

Nelson, W.J., 1995. Structural features in Illinois, Illinois State Geological Survey Bulletin 100, 144 p.

2.3 Maps and Cross Sections.

Two vertical cross-sections and the location map of the proposed injection site are shown in Figures 2-5 through 2-7. Based on interpretation of 3D seismic data collected for the IBDP, two cross-sections were developed showing the bedrock stratigraphy at the proposed well site. Line A-A' is a west to east cross-section, while Line B-B' is a south to north cross-section. The site elevation is approximately 660 feet. The cross-sections provide elevations on the y axis and have no vertical exaggeration. The seismic data were analyzed and interpreted by Alan Brown (Schlumberger Carbon Services) and Hannes Leetaru (ISGS). The cross-sections were prepared by Valerie Smith, Schlumberger Carbon Services.

Excluding the IBDP injection well (herein referenced as CCS #1) and the IBDP verification well (herein referenced as Verification Well #1), no other deep wells penetrate the Eminence, Ironton-Galesville, Eau Claire or Mt. Simon Formations (Figure 2-8) within the area of review (reference Section 5 for area of review information). All of the deeper horizons are projected from regional mapping. Therefore, well locations are not displayed on the cross-sections (Figures 2-6 and 2-7).

2.4 Injection Zone.

Information on the injection zone (Mt. Simon Sandstone) is based on regional geologic information from previous ISGS studies and reports, and on specific data obtained from the CCS #1 well installation (Frommelt, 2010).

Regional

The thickest and most widespread saline water bearing reservoir (saline reservoir) in the Illinois Basin is the Cambrian-age Mt. Simon Sandstone (Figure 2-8). It is overlain by the Cambrian Eau Claire Formation, a regionally extensive very low-permeability unit, and underlain by Precambrian granitic basement. There are records of 21 wells in central and southern Illinois that were drilled into the Mt. Simon (to depths greater than 4,500 feet). Many of the 21 wells penetrate less than a few hundred feet into the Mt. Simon. In addition, most wells are older and lack a suite of modern geophysical logs suitable for petrophysical analysis. Although comprehensive reservoir data for the Mt. Simon are lacking, there are sufficient data to demonstrate its regional presence. In the northern half of Illinois, the Mt. Simon is used extensively for natural gas storage and detailed reservoir data are available from these projects. Ten Mt. Simon gas storage projects show that the upper 200 feet has porosity and permeability high enough to be a good sequestration target. Excluding CCS #1 and Verification Well #1, the closest Mt. Simon penetration to the ADM site is about 17 miles southeast in Moultrie County, the Sanders Harrison #1 (Harrison #1). Only the top two hundred feet of the Mt. Simon was drilled. Based on logs from the IBDP injection and verification wells, the Mt. Simon thickness at the proposed injection site is anticipated to be about 1,500 feet.

Sample descriptions from the Harrison #1 well indicate that there is good porosity in the top 200 feet of the Mt. Simon. The nearest well with a porosity log for the entire thickness of the Mt. Simon, the Humble Oil Weaber-Horn #1 well (Weaber-Horn #1), was drilled on the Loudon Field anticline in Fayette County, a major oilfield 51 miles south of the ADM site. The Weaber-Horn #1 drilled through 1,300 feet of Mt. Simon before drilling into the Precambrian granite. The top of the Mt. Simon at the Weaber-Horn #1 well was at 7,000 feet and, based on

calculations from wireline logs, the sandstone formation's gross thickness had an average porosity of about 12 percent. The Weaber-Horn #1 well log porosity data are similar to those found in deeper wells at the Manlove gas storage field (Manlove Field) in Champaign County, approximately 37 miles northeast of the ADM site. The Manlove Field is the deepest Mt. Simon gas storage field in the Illinois Basin and provides one of the best reservoir data sets for characterization of the deep Mt. Simon. The permeability at the Weaber-Horn #1 well and the ADM site are expected to be similar to those at Manlove Field. A north-south trending cross section A-A' across the Hinton #7, Harrison #1, CCS #1, and Weaber-Horn #1 wells (Figure 2-9) shows that the Mt. Simon should be porous and thick at the proposed site.

Regional Geology: Depositional Environment

The deposition of the Mt. Simon Sandstone has commonly been interpreted to be a shallow, subtidal marine environment. Most of these studies, however, were based on either surface study of the upper part of the Mt. Simon or on study of outcrops in Wisconsin or the Ozark Dome. Based on studies of the samples and logs of the CCS #1 well, the upper part of the Mt. Simon is interpreted to have been deposited in a tidally influence system similar to the reservoirs used for natural gas storage in northern Illinois. However, the basal 600 feet of Mt. Simon sandstone is an arkosic sandstone that was originally deposited in a braided river – alluvial fan system. This lower Mt. Simon Sandstone is the principal target reservoir for sequestration because the dissolution of feldspar grains formed abundant amounts of secondary porosity.

Source:

Driese, S.G., C.W. Byers, and R.H. Dott, Jr., 1981. Tidal deposition in the basal Upper Cambrian Mt. Simon Formation in Wisconsin: *Journal of Sedimentary Petrology*, v. 51, no. 2, p. 367–381.

Droste, J.B., and R.H. Shaver, 1983. Atlas of early and middle Paleozoic paleogeography of the southern Great Lakes area: Indiana Department of Natural Resources, Indiana Geological Survey, Special Report 32, 32 p.

Frommelt, D., 2010. Letter to the Illinois Environmental Protection Agency, Subject: CCS Well #1 Completion Report, Archer Daniels Midland Company – UIC Permit UIC-012-ADM, dated May 5, 2010.

Kolata, D.R., 1991. Illinois basin geometry, in M.W. Leighton, D.R. Kolata, D.F. Oltz, and J.J. Eidel, eds., *Interior cratonic basins: American Association of Petroleum Geologists, Memoir 51*, p. 197.

Sargent, M.L., and Z. Lasemi, 1993. Tidally dominated depositional environment for the Mt. Simon Sandstone in central Illinois: *Great Lakes Section, Geological Society of America, Abstracts and Programs*, v. 25, no. 3, p. 78.

2.4.1 Geologic Name(s) of Injection Zone.

The proposed injection zone (refer to Section 2.4.2 for anticipated depth) is the Cambrian-age Mt. Simon Sandstone. CO₂ injected through the well will be contained in the injection zone and will flow into the Mt. Simon at the injection interval. The injection interval is a portion of the Mt. Simon where the injection well is perforated.

2.4.2 Depth Interval of Injection Zone Beneath Land Surface.

The Mt. Simon was found at a depth of 5,545 feet to 7,051 feet (Frommelt, 2010) based on borehole logging data for the CCS #1 well. An interval of high porosity and permeability was identified at the base of the Mt. Simon. This basal interval was selected as the initial injection interval for the CCS #1 well and was perforated from 6,982 to 7,050 feet.

For the IL-ICCS CO₂ injection project, the planned injection interval is a relatively high permeability zone in the lower Mt. Simon. The approximate gross interval is 6,700 to 7,050 feet. The perforation depths are to be finalized after drilling and will be reported in the well completion report.

2.4.3. Characteristics of the Injection Zone.

Based on the data from the CCS #1 well (Frommelt, 2010), the proposed injection zone is expected to be a porous and permeable sandstone that, in some intervals, is an arkosic sandstone. Grain size varies from very-fine grained to coarse grained. The sandstones are primarily composed of quartz, but some intervals contain more than 15 percent feldspar. Diagenetic clay minerals are not common.

2.4.3.1 Lithologic Description

The Mt. Simon Sandstone regionally varies in lithology from conglomerates to sandstone to shale. Six dominant lithofacies have been recognized: cobble conglomerate, stratified gravel conglomerate, poorly-sorted sandstone, well-sorted sandstone, interstratified sandstone and shale, and shale (Bowen et al., 2011).

The poorly-sorted sandstone lithofacies is the most common regionally and within the Mt. Simon in the CCS #1 well, which contains discrete intervals of predominantly finer-grained sandstone and coarser-grained sandstone. The basal portions of some of the coarser-grained strata are often conglomeratic. In addition, the arkosic interval at the base of the Mt. Simon in the CCS #1 well is about 40 feet thick and interbeds of dark gray shale laminae occur between some of the sandstone strata (Morse and Leetaru, 2005).

The principal cementing material is quartz in the form of overgrowths and feldspar precipitation. Most of the very fine-grained intervals contain large amounts of detrital and authigenic potassium feldspar. The lower part of the Mt. Simon tends to have more feldspar-rich zones than the upper part. These zones consequently tend to have greater feldspar framework grain dissolution and increased porosity. These feldspar-rich intervals may have the best reservoir characteristics for sequestration (Bowen et al. 2011).

Source:

Bowen, B.B., R.I. Ochoa, N.D. Wilkens, J. Brophy, T.R. Lovell, N. Fischietto, C.R Medina, and J.A. Rupp, 2011. Depositional and Diagenetic Variability Within the Cambrian Mount Simon Sandstone: Implications for Carbon Dioxide Sequestration: Environmental Geosciences, v. 18, p. 69-89.

Morse, D.G., and H.E. Leetaru, 2005. Reservoir characterization and three-dimensional models of Mt. Simon Gas Storage Fields in the Illinois Basin: Illinois State Geological Survey, Circular 567, 72 p. CD-ROM.

2.4.3.2 Injection Zone Thickness

The entire (gross) Mt. Simon interval is estimated to be 1,500 feet in thickness, based on CCS #1 well logs. Drilling and testing of the CCS #1 injection well has determined the thickness of individual porous intervals.

While CO₂ may be stored in the entire thickness, the perforated or injection interval will be much smaller and is planned for a high porosity zone relatively deep in the Mt. Simon. Injectivity is primarily a product of net formation thickness (b) and permeability (k) or permeability-thickness (kb), while storage volume is primarily a function of net formation thickness and effective porosity. Because of the thickness and permeability of the Mt. Simon noted in the CCS #1 well, Weaber-Horn, and Hinton wells, nominal injection capacity of 3,000 metric tonnes per day (MT/day) is anticipated to be highly probable. CO₂ reservoir flow modeling (see Section 5.4 of this application) shows that the lower zone can readily accept the 3,000 MT/day injection rate.

2.4.3.3 Fracture Pressure at Top of Injection Zone

At the CCS #1 well, a step-rate test (Earlougher, 1977) was conducted on September 26, 2009 into the initial 25-foot perforated interval from 7,025 to 7,050 feet at the base of the Mt. Simon. The primary purpose of the test was to estimate the fracture pressure of the injection interval. A bottom-hole pressure gauge with surface readout was used. The pressure gauge was located at 6,891 feet inside the tubing, 134 feet above the uppermost perforation.

Water with clay-stabilizing potassium chloride was injected in 2.0 barrel per minute (bpm) increments starting at 2.0 bpm (84 gallons per min, gpm) to 8.0 bpm (336 gpm). Each rate was maintained for approximately 45 minutes. The pressure near the end of each injection period was plotted against the injection rate to determine the fracture pressure (Figure 2-10).

In Figure 2-10, the first line with the greater slope at lower rates and pressure is the perforated interval's response to water injection prior to fracturing. The second line with the lower slope at higher rates and pressures is after the fracture developed. The intersection of the two straight lines is 4,966 psig. To find the fracture pressure at the top of the perforations, the hydrostatic pressure of the water in the wellbore between 6,891 (location of pressure gauge) and 7,025 feet was added to the 4,966 psig. The fracture pressure at 7,025 feet is 5,024 psig. This corresponds to a fracture gradient of 0.715 psi/ft.

Based on this fracture gradient, the fracture pressure at the estimated depth of the uppermost perforation requested in the permit for this well (6,700 ft) is calculated to be 4,790 psi.

Source:

Earlougher, Jr., R.C., 1977. *Advances in Well Test Analysis*, Monograph Series, Society of Petroleum Engineers of AIME, Dallas.

2.4.3.4 Effective Porosity

Compensated neutron and litho-density open-hole porosity logs run were run in the CCS #1 well. The neutron and density logs provide total porosity data. Effective porosity was determined by lab testing using helium porosimetry on a limited number of core plug samples. See Appendix X of the CCS #1 well completion report (Frommelt, 2010) for additional discussion about the helium porosimetry method.

A comparison was made between the neutron-density crossplot porosity (average neutron and density porosity) and core porosity (Figure 2-11). These porosity sources compared well. Consequently, the neutron-density crossplot porosity was used to estimate effective porosity.

Based on porosity trends, there are 7 major sub-intervals present in the Mt. Simon. Table 2-1 lists the intervals identified and the average effective porosity of each. Based on the neutron-density crossplot porosity, the 68-foot injection interval for CCS #1 (6,982-7,050 feet) had an average effective porosity of 21.0%.

Table 2-1: Average effective porosity based on the neutron-density crossplot porosity for CCS #1. The seven sub-intervals were selected based on major changes in the trend of porosity from the neutron-density logs.

| Sub-Interval (feet) | Effective Porosity (%) |
|------------------------|---------------------------|
| 5,545-5,900 | 10.8 |
| 5,900-6,150 | 8.72 |
| 6,150-6,430 | 10.1 |
| 6,430-6,650 | 15.2 |
| 6,650-6,820 | 21.8 |
| 6,820-7,050 | 18.7 |
| 7,050-7,165 | 9.84 |

2.4.3.5 Intrinsic Permeability

Intrinsic permeability, k , was directly available from the results of the core analyses and well testing of CCS #1. However, to estimate permeability over a larger interval where core is not available, a relationship between core permeability and log porosity is required.

Core Analysis

A core porosity-permeability transform was developed (Figure 2-12) based on grain size. Grain size was determined by use of the cementation exponent, m , from Archie's equation (Archie, 1942). This transform was used with a neutron-density crossplot porosity to estimate permeability with depth. Average permeability for sub-intervals of the Mt. Simon for CCS #1 is in Table 2-2. Based on the neutron-density crossplot porosity and the core porosity-permeability transform, the 68-foot injection (perforated) interval (6,982-7,050 feet) in CCS #1 has a geometrical average intrinsic permeability of 194 mD (Frommelt, 2010).

Table 2-2: Average intrinsic permeability based on a transform of core permeability and core porosity related to the neutron-density crossplot porosity for the sub-intervals shown. The seven sub-intervals were selected based on major changes in the trend of porosity from the neutron-density logs.

| Sub-Interval (feet) | Intrinsic Permeability (mD) |
|------------------------|--------------------------------|
| 5,545-5,900 | 19.4 |
| 5,900-6,150 | 10.2 |
| 6,150-6,430 | 8.44 |
| 6,430-6,650 | 8.21 |
| 6,650-6,820 | 8.64 |
| 6,820-7,050 | 107 |
| 7,050-7,165 | 4.37 |

Source:

Archie, G.E., 1942. The electrical resistivity log as an aid in determining some reservoir characteristics: *Journal of Petroleum Technology*, v. 5, p. 54-62.

Well Testing

Three pressure falloff (PFO) tests of varying duration were conducted in September and October 2009 as part of the initial completion of CCS #1 (Frommelt, 2010). A pressure falloff test involves two segments. During the first test segment, the reservoir is stressed by injecting fluid, which increases the reservoir pressure. During the second test segment, the reservoir pressure is monitored as it returns to its pre-test pressure. The initial perforations in the injection interval were 7,025 to 7,050 feet. Water treated with a clay-stabilizing potassium chloride was injected at 1.5 to 2.0 barrels per minute (bpm) (63 to 84 gallons per minute) for nearly two hours. A 19.5 hour PFO followed this injection period.

After this test, these perforations were acidized and a step-rate test was conducted. For the second step-rate test, treated water was injected at 3.1 bpm (130 gpm) for five hours, while pressure was monitored for approximately 45 hours.

The third PFO test was conducted after the well was perforated and stimulated. An additional 30 feet of perforations were added at 6,982 to 7,012 feet. The perforated zone received a second acid treatment. Additional information regarding perforations and acid treatment are described in the CCS #1 Completion Report, Appendix X (Frommelt, 2010). For the third PFO test, the treated water was injected at an increasing rate of 3.1 to 4.2 bpm (130 to 176 gpm) over 6.5 hours and then at 4.2 bpm (176 gpm) for an additional 6.5 hours. During this third PFO test, pressure was monitored for 105 hours.

Pressure Transient Analyses

PIE pressure transient software was used to analyze the pressure data for reservoir flow properties. Conventional semi-log, log-log and nonlinear regression analyses were used to analyze the data. (Well-Test Solutions, Ltd., <http://welltestsolutions.com/index.html>)

During the first PFO, because only 25 feet of perforations were open in a very large vertical formation (gross thickness 1,506 feet), a partial penetration or partial completion effect was expected. The derivative (log-log plot) of the falloff test is used to qualitatively identify reservoir features including the partial penetration effect (reference Figure 2-13) and to determine permeability. Two radial, 2-dimensional responses (horizontal derivative) were measured during this test between 0.1 and 1 hrs (PPNSTB) and 20 to 100 hrs (STABIL). The first period corresponds to radial flow across the 25 feet perforated interval; the second period corresponds to the pressure response across a larger thickness that would be between two much lower permeability sub-units. The transition between the two radial responses (SPHERE) is a spherical flow (3-dimensional flow) period that is influenced by vertical permeability or the ratio of vertical to horizontal permeability (k_v/k_h).

To observe the effect of the acid treatment and the second set of perforations to the overall injection interval, the derivatives of the three pressure falloff tests were overlain (Figure 2-14). The data between 0.1 and 1.0 hrs match relatively well and the data between 1.0 and 100 hrs match very well. Similar trends of the first radial period, transition and final radial period indicates that the second set of perforations did not change the permeability estimated from the pressure transient tests or contribute to the perforated interval. As such, the subsequent pressure transient analyses used a single layer, partial penetration model with 25 feet of perforations open at the base of the layer.

Simulation of the pressure transient data using analytical solutions (Figure 2-15), gave a permeability of 185 mD over 75 feet of vertical thickness. The transition period gave a vertical permeability over the 75 feet as 2.45 mD ($k_v/k_h = 0.0133$). The Mt. Simon initial pressure at CCS #1 at 7,025 feet is about 3,200 psig.

For the injection interval, the permeability estimates from the different methods are very close. Based on the neutron-density crossplot porosity and the core porosity-permeability transform, the 68-foot, injection (perforated) interval (6,982 to 7,050 feet) has an average intrinsic permeability of 194 mD. Using the PIE pressure transient software for the third PFO, permeability was estimated to be 185 mD over 75 feet of vertical thickness. Permeability for this same 75 feet of rock was calculated using core and well log analyses. The permeability from this analysis was estimated to be 182 mD.

Source:

Leetaru, H.E., D.G. Morse, R. Bauer, S. Frailey, D. Keefer, D. Kolata, C. Korose, E. Mehnert, S. Rittenhouse, J. Drahovzal, S. Fisher, J. McBride, 2005. Saline reservoirs as a sequestration target, in An Assessment of Geological Carbon Sequestration Options in the Illinois Basin, Final Report for U.S. DOE Contract: DE-FC26-03NT41994, Principal Investigator: Robert Finley, p 253-324

2.4.3.6 Hydraulic Conductivity

Intrinsic permeability (k) and hydraulic conductivity (K) are related according to the following equation (Freeze and Cherry, 1979):

$$K = k \rho g / \mu$$

where ρ = fluid density
 g = gravitational acceleration
 μ = dynamic viscosity

Intrinsic permeability (k) is a property of the rock, while hydraulic conductivity (K) includes properties of the rock and fluid. Intrinsic permeability is also known as permeability and is discussed in Section 2.4.3.5. Formation water density and dynamic viscosity are discussed in Sections 2.4.4.3 and 2.4.4.4, respectively. For the range of viscosity and density discussed, the hydraulic conductivity will vary.

The 68-foot injection interval in CCS #1 (6,982 to 7,050 feet) had an average intrinsic permeability of 194 mD (see Section 2.4.3.5); this converts to a hydraulic conductivity of 3.9×10^{-4} cm/sec, using the fluid properties at this depth.

Source:

Freeze, R. A. and J. A. Cherry, 1979. *Groundwater*. Englewood Cliffs, N.J., Prentice-Hall, Inc.

2.4.3.7 Storage Coefficient

The storage coefficient or storativity, S , ranges from 5×10^{-5} to 5×10^{-3} for confined aquifers (Freeze and Cherry, 1979). S is commonly determined by well testing; however, S is a function of fluid compressibility (c_f) and rock compressibility (c_r) and can be estimated from the following equation:

$$S = \rho g h(c_r + \phi c_f)$$

where ϕ = porosity
 h = formation thickness
 ρ = fluid density
 g = gravitational acceleration

Rock compressibility can be expressed as the inverse of the bulk modulus (K_b) and in terms of the Young's modulus (E) and Poisson's ratio (ν) (Huang and Rudnicki, 2006):

$$c_r = 1/K_b = 3(1 - 2\nu)/E$$

Fluid density is discussed in Section 2.4.4.3. Gravitational acceleration approximately equals 9.81 m/sec^2 . For this calculation, the Mt. Simon is assumed to be 1,506 feet thick and have 10% porosity (Φ). Young's modulus (E) and Poisson's ratio (ν) were determined by Weatherford Laboratory (see CCS #1 Completion Report, Appendix X (Frommelt, 2010) for more details) for Mt. Simon samples collected at depths of 6,761 and 6,770 feet. These values were used to compute c_r using the equation shown above. These compressibility values are consistent with bulk compressibility values for sandstone reservoirs, which ranged from 6.5×10^{-5} to $2.7 \times 10^{-4} \text{ MPa}^{-1}$ at 7,000 psi (48.3 MPa) confining pressure (Zimmerman, 1991). Fluid compressibility (c_f) is known to vary with pressure and temperature changes (Huang and Rudnicki, 2006). Using two samples collected from CCS #1 (MDT-1 & MDT-4), fluid compressibility and storativity values were estimated (reference Section 2.4.4, Table 2-4).

Based on the range of values described here, storativity was estimated to range from 4.9×10^{-5} to 9.0×10^{-4} (Table 2-3). These values are consistent with values published by Freeze and Cherry (1979).

Table 2-3. Estimates of rock (c_r) and fluid (c_f) compressibility and storativity (S) for CCS #1

| Depth (ft) | Pressure (psi) | Pressure (MPa) | T (°C) | ρ (g/L) | c_r (1/Mpa) | c_f (1/Mpa) | Φ (-) | h (m) | S (vol/vol) |
|------------|----------------|----------------|--------|--------------|---------------|---------------|------------|-------|-------------|
| 5772 | 2582.9 | 1.78E+01 | 48.8 | 1089.7 | 2.02E-04 | 2.04E-04 | 0.132 | 459.0 | 8.59E-04 |
| 7045 | 3206.1 | 2.21E+01 | 52.1 | 1123.5 | 2.02E-04 | 1.83E-04 | 0.132 | 459.0 | 9.00E-04 |
| 5772 | 2582.9 | 1.78E+01 | 48.8 | 1089.7 | 3.68E-05 | 2.04E-04 | 0.132 | 459.0 | 4.87E-05 |
| 7045 | 3206.1 | 2.21E+01 | 52.1 | 1123.5 | 3.68E-05 | 1.83E-04 | 0.132 | 459.0 | 6.38E-05 |

2.4.3.8 Seepage Velocity (ft/yr) and Flow Direction of Formation Water

Groundwater flow in the deeper part of the Illinois Basin is not well understood because few wells penetrate deep formations such as the Mt. Simon Sandstone. However, based on limited field data and numerical modeling some information on groundwater flow is available.

Within the Mt. Simon Sandstone, Bond (1972) determined that groundwater flows from west to east beneath the northern third of Illinois. Bond (1972) also noted that groundwater flows to the south in the deeper part of the Illinois Basin, but some data supporting this conclusion were questionable. Groundwater flow in the Mt. Simon Sandstone is generally very slow, on the order of inches per year. Finally, Bond (1972) noted that groundwater flows upward from the Mt. Simon aquifer to the Ironton-Galesville in the Chicago area, where pumpage has lowered pressures in the Ironton-Galesville. Gupta and Bair (1997) used a steady-state, variable density, groundwater flow model to evaluate flow in the Mt. Simon Sandstone in the Midwest (Ohio, Indiana and parts of Illinois, Wisconsin, Michigan, Pennsylvania, West Virginia and Kentucky), including the eastern portion of the Illinois Basin. Results from this modeling indicated that flow in the shallow layers, such as in the Pennsylvanian bedrock, follows topographic-driving forces – recharge in upland areas and discharge in topographic lows such as river valleys. For deeper layers such as the Mt. Simon Sandstone, the flow patterns are influenced by the geologic structure with flow away from arches such as the Kankakee Arch and toward the deeper parts of the Illinois Basin (Figure 2-16). The model also indicated that groundwater flows upward from the Mt. Simon to the Eau Claire and downward from the Ironton-Galesville into the Eau Claire (Figure 2-17), but these vertical velocities are very small, <0.01 inches per year. Gupta and Bair (1997) estimated that 17% of the water entering the Mt. Simon exits via upward leakage into the upper confining layer, while the remaining 83% flows laterally.

The modeling results of Gupta and Bair agree with results of Cartwright (1970). Cartwright (1970) estimated that 59,000 acre-ft of groundwater discharged from the Illinois Basin bedrock to streams. Cartwright (1970) also argued that 95% of this discharge flowed through vertical fractures in the Wabash valley fault zone and the Duquoin-Louden anticlinal belt. These modeling results also agree with a hypothesis described by Bredehoeft et al. (1963) to explain the high brine concentrations (3 to 6 times higher than present seawater) found in some deep basins including the Illinois Basin. Bredehoeft et al. (1963) argued that confining layers such as the Eau Claire act as semi-permeable membranes, allowing water to pass out of permeable formations such as the Mt. Simon while retarding the passage of charged salt particles. The clay minerals in the confining layer have a net negative charge which retards the anions in the water.

These anions then retard the movement of the cations (positive charge) via electrical attraction. This process happens very slowly, over geologic time periods of hundreds of thousands of years.

The information presented above reflects our current understanding on groundwater flow in the Illinois Basin. This understanding is based on very limited data of which some is specific to the Mt. Simon but outside of the Illinois Basin. Intensive monitoring of the CO₂ plume during and after injection is expected to provide additional information.

Source:

Bond, D.C., 1972. Hydrodynamics in deep aquifer of the Illinois Basin, Illinois State Geological Survey Circular 470, Urbana, IL, 72 p.

Bredehoeft, J.D., C.R. Blyth, W.A. White and G.B. Maxey, 1963. Possible mechanism for concentration of brines in subsurface formations. Bulletin of the American Association of Petroleum Geologists 47(2): 257-269.

Cartwright, K., 1970. Groundwater discharge in the Illinois Basin as suggested by temperature anomalies: Water Resources Research, vol. 6, no. 3, p. 912-918.

Gupta, N. and E.S. Bair, 1997. Variable-density flow in the midcontinent basins and arches region of the United States, Water Resources Research, 33(8): 1785-1802.

Huang, T. and Rudnicki, J.W., 2006. A mathematical model for seepage of deeply buried groundwater under higher temperature and pressure, Journal of Hydrology, Vol. 327, 42-54.

Zimmerman, R.W., 1991. Compressibility of sandstones, Elsevier Publishing Co., Amsterdam.

2.4.4 Characteristics of Injection Zone Formation Water

Information on the injection zone formation water is primarily based on specific data obtained from the CCS #1 well installation (Frommelt, 2010). Fluid samples were collected from the CCS #1 open borehole after drilling and wireline geophysical testing were completed. Schlumberger's Modular Formation Dynamics Tester (MDT) and Quiksilver wireline equipment were run on April 28 and 29, 2009. The tool was used to collect formation pressure, formation temperature, and high-quality reservoir fluid samples at five depths (Table 2-4). Prior to collecting a reservoir sample, the MDT measures the fluid resistivity to help discriminate between formation fluids and drilling mud filtrate. Fluid sample volume varied from 450 mL to 900 mL. These samples were analyzed by the Illinois State Water Survey.

Table 2-4. Data for fluid samples collected from the Mt. Simon sandstone in CCS#1 using the MDT sampler in April 2009

| Sample ID | Sample Depth (feet) | Formation Pressure (psi) | Formation Temperature (°F) | TDS (mg/L) | Density (g/L) |
|-----------|---------------------|--------------------------|----------------------------|------------|---------------|
| MDT-4 | 5,772 | 2,582.9 | 119.8 | 164,500 | 1,089.7 |
| MDT-3 | 6,764 | 3,077.5 | 125.1 | 185,600 | 1,120.7 |
| MDT-14 | 6,764 | 3,077.5 | 125.1 | 179,800 | Not analyzed |
| MDT-5 | 6,840 | 3,105.9 | 125.0 | 182,300 | 1,124.1 |
| MDT-2 | 6,912 | 3,141.8 | 125.8 | 211,700 | 1,136.5 |
| MDT-9 | 6,840 | 3,105.9 | 125.0 | 219,800 | Not analyzed |
| MDT-1 | 7,045 | 3,206.1 | 125.7 | 228,100 | 1,123.5 |
| MDT-8 | 7,045 | 3,206.1 | 125.7 | 201,500 | Not analyzed |

2.4.4.1 Temperature

Based on the MDT sampler (Table 2-4), formation temperatures ranged from 119.8°F (48.8 °C) at a depth of 5,772 feet to 125.8°F (52.1°C) at depth of 6,912 feet.

2.4.4.2 Pressure

The formation pressure measured with the MDT tool in CCS #1 (Table 2-4) varied with depth and had a minimum pressure of 2,583 psi recorded at 5,772 feet and a maximum pressure of 3,206 psi recorded at 7,045 feet.

2.4.4.3 Density

Based on five brine samples collected with the MDT sampler at the CCS #1 well, the fluid density ranged from 1,090 to 1,137 g/L, with an average of 1,119 g/L.

2.4.4.4 Viscosity

Dynamic viscosity is a function of brine temperature, salinity, and formation pressure. Viscosity increases with higher salinity and with lower temperatures. Viscosity slightly increases with higher formation pressure (Kestin et al., 1981). Kestin et al. (1981) studied the viscosity of NaCl brines.

Because the Mt. Simon brine is predominantly NaCl brine, using the method of Kestin et al. (1981) is appropriate. Using the data in Table 2-4, the brine viscosity for the Mt. Simon brine is estimated to range from 5.4×10^{-4} to 5.7×10^{-4} Pa sec with an average of 5.5×10^{-4} Pa sec.

Source:

Kestin, J., E. Khalifa and R.J. Correia, 1981. Tables of dynamic and kinematic viscosity of aqueous NaCl solutions in the temperature range 20-150°C and the pressure range 0.1-35 MPa. *Journal of Physical and Chemical Reference Data*, 10(1): 71-87.

2.4.4.5 Total Dissolved Solids

Salinity, expressed as TDS, also affects the injection capacity because it reduces the CO₂ solubility in water. Figure 2-18 illustrates the relative density of deep aquifer brines in the Illinois Basin. Figure 2-19 shows the broad distribution of TDS in the Mt. Simon which should exceed 60,000 mg/L over much of the Illinois Basin and 180,000 mg/L in the deeper portions of the basin. Figure 2-19 also shows the approximate position of the 20,000 mg/L TDS iso-concentration line for the Mt. Simon Sandstone in the northern part of the State. South of this line, the groundwater is expected to exceed 20,000 mg/L TDS.

At the IBDP site, samples collected from CCS #1 varied with depth (Table 2-4), with TDS of 164,500 mg/L TDS at 5,772 feet and 228,100 mg/L TDS at 7,045 feet. The average TDS for the eight samples is 196,700 mg/L. The proposed IL-ICCS site is within one mile of the CCS #1 well and similar concentrations of TDS are anticipated.

Source:

Leetaru, H.E., D.G. Morse, R. Bauer, S. Frailey, D. Keefer, D. Kolata, C. Korose, E. Mehnert, S. Rittenhouse, J. Drahovzal, S. Fisher, J. McBride, 2005. Saline reservoirs as a sequestration target, in *An Assessment of Geological Carbon Sequestration Options in the Illinois Basin*, Final Report for U.S. DOE Contract: DE-FC26-03NT41994, Principal Investigator: Robert Finley, p 253-324

2.4.4.6 Potentiometric Surface

Little information is available about the potentiometric surface in the Mt. Simon sandstone in Macon County because very few wells penetrate the Mt. Simon in central Illinois. The best available information regarding the potentiometric surface is discussed in Section 2.4.3.8 of this document.

Using the formation pressure (p) and fluid density (ρ) data in Table 2-4, the potentiometric head (b) was calculated using the relationship $p = \rho gh$, where g is the gravitational constant. The mean potentiometric head in the Mt. Simon has an elevation 249.5 feet MSL. If the well were filled with freshwater ($\rho = 1,000$ g/L), the potentiometric head would have an elevation of 996.1 feet MSL.

2.4.5 Additional or Alternative Zones Considered for Injection

No other geologic zones are being considered for sequestration at the IL-ICCS site.

2.5 Upper Confining Zone

Information on the upper confining zone, the Eau Claire Formation, is based on specific data obtained from the CCS #1 well installation (Frommelt, 2010) and is supplemented by regional geologic information from previous ISGS studies and reports. In order for a saline reservoir to be used for injection of CO₂, there must be an effective hydrologic seal that restricts upward fluid movement. Within the Illinois Basin, three thick and wide-spread shale units function as major regional seals. These units are the Cambrian-age Eau Claire Formation, the Ordovician-age

Maquoketa Formation, and the Devonian-age New Albany Shale (Figure 2-8). The Eau Claire Formation has no known penetrations (with the exception of the IBDP injection and verification wells) within a 17-mile radius surrounding the proposed IL-ICCS site; therefore, integrity of wellbores is not an issue.

Gas storage projects in the Illinois Basin confirm that the Eau Claire is an effective seal in the northern and central portions of the Basin. Core analysis data from the Manlove Gas Storage Field, 37 miles to the northeast of the proposed site, show that the Eau Claire shale intervals have vertical and horizontal permeability less than 0.1 mD.

A diagrammatic north-south cross section of the Basin through the central part of Illinois (Figure 2-20) shows that the Eau Claire Formation, the primary seal, has a laterally persistent shale interval above the Mt. Simon and is expected to provide an excellent seal.

Wireline logs from the CCS #1 well and two geologic cross sections near the proposed site (Figures 2-6 and 2-7) indicate that at the IL-ICCS site, there should be about 500 feet of Eau Claire Formation directly above the Mt. Simon Sandstone.

2.5.1 Geologic Name(s) of Confining Zone

The primary confining zone (seal) is the Cambrian-age Eau Claire Formation (Figure 2-8). Based on the data from CCS #1, the Eau Claire has a total thickness of 497.5 feet. The shale section of the Eau Claire has a thickness of 198.1 feet and is the lowermost section within the formation.

2.5.2 Depth Interval of Upper Confining Zone Beneath Land Surface

At CCS #1, the Eau Claire Formation occurs at a depth of 5,047 feet to 5,545 feet below ground surface. The shale section of the Eau Claire occurs at a depth of 5,347 to 5,545 feet.

2.5.3 Characteristics of Confining Zone

2.5.3.1 Lithologic Description

The Cambrian-age Eau Claire Formation is composed primarily of a silty, argillaceous dolomitic sandstone or sandy dolomite in northern Illinois and becomes a siltstone or shale in the central part of the Illinois Basin (Willman et al., 1975). In the southern part of the basin, the Eau Claire is a mixture of dolomite and limestone with some fine-grained siliciclastics.

In the CCS #1 well, the upper section of the Eau Claire (5,047 to 5,347 feet) is a dense limestone with thin stringers of siltstone. The lower section of the Eau Claire (5,347 to 5,545 feet) consists of shale.

From limited x-ray diffraction data, the mineralogy of the shale is 60 percent clay minerals and 37 percent quartz and potassium feldspar. The shale is laminated and dark gray to black in color.

Source:

Willman, H.B., E. Atherton, T.C. Buschbach, C. Collinson, J.C. Frye, M.E. Hopkins, J.A. Lineback, and J.A. Simon, 1975. Handbook of Illinois Stratigraphy, Illinois State Geological Survey Bulletin 95, 261 pp.

2.5.3.2 Geomechanical Data

Geomechanical data were collected by lab and field testing. Lab testing was used to determine elastic parameters for a single Eau Claire shale sample. Field testing, a mini-frac test, was conducted to determine the in situ fracture pressure.

An Eau Claire shale sample was collected from CCS #1 at a depth of 5,478.5 feet. This sample was tested by Weatherford Labs (Houston, TX) and has the following properties—Young's modulus of 5.50×10^6 psi, Poisson's ratio of 0.27, bulk modulus of 3.92×10^6 and shear modulus of 2.17×10^6 psi.

“Mini-frac” testing was conducted within the Eau Claire to determine the effectiveness of the shale as a caprock seal (Frommelt, 2010). Mini-fracs are very small volume tests that inject fluid up to the parting pressure of the injection zone.

A mini-frac test using Schlumberger's Modular Dynamics Testing tool was conducted across a 2.8-foot shale interval of the Eau Claire, centered at a depth of 5,435 feet. The test was designed for four short-term injection/falloff test periods (15 to 60 minutes in duration). The fracture pressure from these four tests ranged from 5,078 to 5,324 psig, corresponding to a fracture gradient ranging from 0.93 to 0.98 psi/ft in the Eau Claire shale.

2.5.3.3 Intrinsic Permeability

None of the CCS #1 sidewall rotary core plugs penetrated shale. From the whole core collected from the Eau Claire, none of the individual shale layers at the inch to centimeter scale were thick enough for obtaining a core plug for permeability analyses.

Within the upper confining interval of 5,047 to 5,545 feet, 12 Eau Claire plugs were available for porosity and permeability testing. The plugs are described as very fine grained sandstones, microcrystalline limestone, and siltstone. Because sidewall rotary core plugs are taken horizontally, the permeability data from these plugs indicate the horizontal (not vertical) permeability. The average horizontal permeability for the 12 sidewall rotary core plugs is 0.000344 mD.

The average vertical permeability for the upper confining shale layer is expected to be much lower than 0.000344 mD because this value is based on the non-shale horizontal permeability values. Vertical permeability on plugs is generally lower than horizontal permeability and shale permeability is generally much lower than sandstone, limestone, and siltstone.

The Illinois State Geological Survey database of UIC wells with core from the Eau Claire was also used to characterize the upper confining seal. This database shows that the Eau Claire's

median permeability is 0.000026 mD and median porosity is 4.7%. At the Ancona Gas Storage Field, located approximately 80 miles to the north of the proposed IL-ICCS site, cores were obtained through 414 feet of the Eau Claire, and 110 analyses were performed on a foot-by-foot basis on the recovered core. Most vertical permeability analyses showed values of <0.001 to 0.001 mD. Only five analyses were in the range of 0.100 to 0.871 mD, the latter being the maximum value in the data set. This indicates that even the more permeable beds in the Eau Claire Formation are expected to be relatively tight and tend to act as sealing lithologies.

Source:

Illinois State Geological Survey Mt. Simon database

2.5.3.4 Hydraulic Conductivity

Intrinsic permeability (k) and hydraulic conductivity (K) are related according to the following equation (Freeze and Cherry, 1979):

$$K = k \rho g / \mu$$

where ρ = fluid density
 g = gravitational acceleration
 μ = dynamic viscosity

Intrinsic permeability (k) is a property of the rock, while hydraulic conductivity (K) includes properties of the rock and fluid. Because fluid samples were not collected from the Eau Claire, the properties of the fluid properties of CCS #1 sample MDT-4 (Table 2-4), which is the Mt. Simon brine sample collected closest to the Eau Claire, were used for these calculations. Its measured properties include temperature of 119.8°F and density of 1,089.7 g/L. Its dynamic viscosity was estimated to be 758.0 μ Pa sec. For an intrinsic permeability value of 0.000344 mD, the hydraulic conductivity equals 4.8×10^{-14} cm/sec.

Source:

Freeze, R.A. and J.A. Cherry, 1979. *Groundwater*. Englewood Cliffs, N.J., Prentice-Hall, Inc.

2.5.3.5 Alternative Confining Zones Proposed, Include Explanation and Depth Interval(s)

Secondary seals provide additional backup containment of the CO₂ should an unlikely failure of the primary seal occur. Secondary seals listed here are units with low permeability that are regionally present and serve as confining seals for oil, gas and gas storage fields throughout Illinois where they are present.

Study of the wireline logs of the CCS #1 well and regional studies indicate that there are two laterally continuous, secondary seals at the IL-ICCS site (Frommelt, 2010). The Ordovician-age Maquoketa Shale is 206 feet thick at the CCS #1 well site with the top at a depth of 2,611 feet below. This shale is a regional seal for hydrocarbon production from the Ordovician Galena (Trenton) Limestone. The top of the Devonian-Mississippian-age New Albany Shale (Figure 2-21) is at a depth of 2,088 feet and is about 126 feet thick at the CCS #1 well site. Extensive data from oil fields through the Illinois Basin shows that this shale is an excellent seal for

hydrocarbons; hence, it should also be an excellent secondary seal against the vertical migration of CO₂ at this site.

There are also many minor, thinner Mississippian- and Pennsylvanian-age shale beds that will also form seals against CO₂ vertical migration.

2.6 Lower Confining Zone

Information on the lower confining zone (Precambrian granite) is based on the specific data obtained from the CCS #1 well installation (Frommelt, 2010).

Because the lower confining zone is the basement granite and no other sedimentary rocks are below the granite, no data will be collected on the granite for the ICCS project. The fracture pressure, porosity, and permeability of the granite will not impact injection or fluid migration as the CO₂ injection interval will almost certainly be above this interval and the CO₂ is expected to move upward away from the granite.

2.6.1 Geologic Name(s) of Confining Zone

The lower confining zone is the Precambrian granite basement.

2.6.2 Depth Interval of Lower Confining Zone Beneath

At CCS #1, the top of the Precambrian granite is at a depth of 7,165 feet, which indicates that the base of the Mt. Simon in the IL-ICCS injection well will be at a similar depth.

2.6.3 Characteristics of Confining Zone

2.6.3.1 Lithologic Description

The Precambrian-age rock in the Illinois Basin is composed of a medium- to coarse-grained granite or rhyolite and is between 1.1 to 1.4 billion years old (Bickford et al., 1986).

Source:

Bickford, M.E., W.R. Van Schmus, and I. Zietz, 1986. Proterozoic history of the mid-continent region of North America: *Geology*, vol. 14, no. 6, pp. 492–496.

2.6.3.2 Fracture Pressure at Depth

The ISGS could not find any data on fracture pressure of granites in Illinois. No tests were conducted at the IBDP injection or verification wells to determine the fracture pressure of the lower confining zone. The fracture pressure of the granite is not anticipated to have any effect on the injection or storage of CO₂ in the overlying Mt. Simon Sandstone.

2.6.3.3 Intrinsic Permeability

The top of the granite occurs at depth of 7,165 feet. A total of 65 feet of granite was drilled at CCS #1. At 7,200 feet, one sidewall core plug was collected; the permeability was determined to be 0.0091 mD.

2.6.3.4 Hydraulic Conductivity

Using the pressure and fluid properties obtained for MDT-1 (Table 2-4), hydraulic conductivity for the granite is estimated to be 1.8×10^{-12} cm/sec.

2.6.3.5 Alternative Confining Zones Propose

There are no alternative lower confining zones since no wells in Illinois have found anything else but the Precambrian granite basement below the Mt. Simon Sandstone.

2.7 Overlying Sources of Groundwater at the Site.

Field investigations to determine the lowermost USDW at the IBDP site were discussed in a letter from Dean Frommelt of ADM to Illinois EPA, dated September 29, 2009. In a December 2, 2009 letter (Nightingale, 2009), the Illinois EPA approved the monitoring of the Pennsylvanian bedrock as the lowermost USDW at the IBDP site. As the IBDP site is located less than one mile from the proposed IL-ICCS project site, it is assumed that similar Pennsylvanian bedrock would be the lowermost USDW at the IL-ICCS site.

Source:

Frommelt, D. 2009. Letter to Illinois Environmental Protection Agency, Subject: Lowermost underground source of drinking water (USDW), Archer Daniels Midland Company – UIC Permit UIC-012-ADM, dated September 29, 2009.

Nightingale, S. 2009. Letter to Archer Daniels Midland Company, Subject: Lowermost underground source of drinking water (USDW), Permit No. UIC-012-ADM, Log No. PS09-206, dated December 2, 2009.

2.7.1 Characteristics of the Aquifer Immediately Overlying the Confining Zone

2.7.1.1 Elevation at Top of Aquifer

The first aquifer which contains salt water at the proposed location overlying the Eau Claire Formation (the primary seal for the Mt. Simon Sandstone) is the Cambrian-age Ironton-Galesville Formation (Figure 2-8). Based on the geophysical logging in CCS #1, the Ironton-Galesville was found at depths of 4,928 to 5,047 feet (119 feet thick) (Frommelt, 2010). This thickness corresponds with regional mapping of the Ironton-Galesville formation that shows it to be between 100 and 150 feet thick at the site (Figure 2-22).

2.7.1.2 Potentiometric Surface

Little information is available about the potentiometric surface in the Ironton-Galesville Formation in Macon County because very few wells penetrate the Ironton-Galesville in central Illinois. The pressures in the Illinois Basin are generally normally pressured at 0.433 psi/ft, so the potentiometric surface of the Ironton-Galesville formation is approximated to be at surface elevation of 670 feet MSL. No potentiometric data were collected during drilling of CCS #1 for the Ironton-Galesville.

2.7.1.3 Total Dissolved Solids

There are no available data on the salinity of the Ironton-Galesville in Macon County. No water quality data were collected during drilling of CCS #1 for the Ironton-Galesville. The closest well with TDS data is the Allied Chemical Waste Disposal Well #1 in Vermillion County (about 73 miles from the IL-ICCS site). The well penetrated the Ironton-Galesville at a depth of 4,096 feet measured depth. The total dissolved solids were measured to be 112,000 mg/L in this well (Brower et al, 1989). In addition, regional mapping of the formation by the USGS shows that the proposed IL-ICCS injection well should encounter saline waters (Figure 2-23) in this interval.

Source:

Brower, R. D., A.P. Visocky, I.G. Krapac, B.R. Hensel, G.R. Peyton, J.S. Nealon and M. Guthrie, 1989. Evaluation of underground injection of industrial waste in Illinois, Illinois Scientific Surveys Joint Report 2: 89.

2.7.1.4 Lithology

The Ironton and Galesville Sandstones are considered in this report as one unit because they are considered to be a single aquifer in the northern part of Illinois (Willman et al., 1975). These two sandstones are difficult to differentiate from each other using wireline logs. The Ironton is a relatively poorly sorted, fine- to coarse-grained, dolomitic sandstone. The Galesville is a sandstone that is relatively better sorted, finer grained, and has better porosity than the overlying Ironton. The CCS #1 well is the only well that penetrated this zone within a 17-mile radius of the proposed site. No lithologic data were for the Ironton-Galesville were collected during the drilling of CCS #1 for the Ironton-Galesville.

Source:

Willman, H.B., E. Atherton, T.C. Buschbach, C. Collinson, J.C. Frye, M.E. Hopkins, J.A. Lineback, and J.A. Simon, 1975. Handbook of Illinois Stratigraphy, Illinois State Geological Survey Bulletin 95, 261 pp.

2.7.1.5 Aquifer Thickness

Based on the geophysical logging in CCS #1, the Ironton-Galesville was found to be 119 feet thick.

2.7.1.6 Specific Gravity

Little information is available about the specific gravity of fluids in the Ironton-Galesville Formation in Macon County because very few wells penetrate the Ironton-Galesville in central Illinois. No water quality data were for the Ironton-Galesville were collected during the drilling of CCS #1 for the Ironton-Galesville.

2.7.2 *Underground Sources of Drinking Water*

2.7.2.1 Maps and Cross Sections

Maps and Cross-sections/ Quaternary Deposits

Sand and gravel aquifers are found in the Quaternary and recent geologic deposits. Larson et al. (2003) described these deposits for DeWitt, Piatt, and northern Macon Counties (Figure 2-24). While the water quality of groundwater in these aquifers is not known precisely, these aquifers are used for water supplies and are considered to be underground sources of drinking water.

The vertical sequence of sand and gravel aquifers in Macon County is illustrated in Figure 2-25. Several sand and gravel aquifers are present. The deepest aquifer is the Mahomet aquifer, which is a major aquifer capable of yielding significant amounts of water (usually >1,000 gpm). Other aquifers are found in the Banner Formation, the Glasford Formation, and more recent sediments. The Mahomet aquifer is not located beneath the IL-ICCS site (Figure 2-26), but is present approximately 5 miles to the north. Sand and gravel aquifers are likely to be thin or absent in the Banner Formation (Figure 2-27), the lower portion of the Glasford Formation (Figure 2-28), and the more recent sediments (Figure 2-29). Sand and gravel aquifers are likely to be 5 to 20 feet thick in the upper portion of the Glasford Formation (Figure 2-30) and are likely found within 100 feet of the ground surface.

Maps and Cross-sections/ Pennsylvanian Bedrock

The uppermost bedrock at the site is Pennsylvanian-age bedrock (Figure 2-31). For the Illinois Department of Natural Resources, Office of Mines and Minerals (IDNR-OMM), the ISGS previously produced county-wide cross-sections to help IDNR-OMM determine the depth of oil-field casing needed to protect underground sources of drinking water (USDW). A cross-section was produced for Christian and Macon Counties, as shown in Figures 2-32 & 2-33 (Vaiden, 1991). These cross-sections were developed using water quality data from the ISWS and estimates from geophysical logs using the technique of Poole et al. (1989). The source of the water quality data is noted on the cross-section. This cross-section indicates that the water quality in the uppermost Pennsylvanian bedrock is less than 10,000 mg/L, but the TDS rapidly increases below the No. 2 Coal (Figures 2-32, 2-33 & 2-34) and generally exceeds 10,000 mg/L.

Maps and Cross-sections/ Mississippian Bedrock

Because water quality data for the Mississippian bedrock is not available at the site or in Macon County, regional data are the only source for this data. They noted that mineralization of groundwater in the Valmeyeran and Chesterian units of the Mississippian System was low in

outcrop (actually subcropping beneath Quaternary strata) areas and reached a maximum of 100,000 to 160,000 mg/L TDS in the Illinois Basin (Figure 2-34). Groundwater with low TDS occurs only in and near the outcrop/subcrop areas except in the broad area between the Illinois and Mississippi Rivers. There are no Mississippian unit outcrop/subcrop areas in Macon County. Figure 2-34 shows the estimated position at which 10,000 mg/L TDS groundwater is encountered in the Valmeyeran and Chesterian, respectively. Based on available data it is not expected that the Mississippian System at the proposed injection site will be a USDW.

Source:

Brower, R. D., A. P. Visocky, I. G. Krapac, B. R. Hensel, G. R. Peyton, J. S. Nealon and M. Guthrie, 1989. Evaluation of underground injection of industrial waste in Illinois, Illinois Scientific Surveys Joint Report 2: 89.

Larson, D.R., B.L. Herzog and T.H. Larson, 2003. Groundwater Geology of DeWitt, Piatt, and Northern Macon Counties, Illinois. Champaign, IL, Illinois State Geological Survey Environmental Geology 155: 35.

Poole, V.L., K. Cartwright and D. Leap, 1989. Use of Geophysical Logs to Estimate Water-Quality of Basal Pennsylvanian Sandstones, Southwestern Illinois. Ground Water 27(5): 682-688.

Vaiden, R.C., 1991. Christian and Macon Counties, Cross-Section E-E'

2.7.2.2 Lowest Depth of Underground Source of Drinking Water (USDW)

The Pennsylvanian bedrock is anticipated to be the lowermost USDW at the IL-ICCS project site. The depth of the lowermost USDW is expected to be similar to the depths found at the IBDP site compliance wells, or approximately 140 feet below the ground surface.

Source: Quarterly Groundwater Report For Illinois EPA Underground Injection Control Permit Number UIC-012-ADM (2010 Q4), Locke, R. and Mehnert, E. December 17, 2010.

2.7.2.3 Elevation of Potentiometric Surface of Lowest USDW Referenced to Mean Sea Level

The potentiometric surface of lowest USDW is expected to be approximately 55 to 59 feet below the ground surface, based on potentiometric data collected from the four groundwater compliance monitoring wells at the IBDP site during the 4th quarter of 2010 (Locke and Mehnert, 2010). The potentiometric surface of the lowermost USDW is anticipated to be approximately 620 feet above MSL at the IL-ICCS project site.

2.7.2.4 Distance to Nearest Water Supply Well

Water well records were found in the Illinois State Water Survey database for three private water supply wells located in the southeast quarter of Section 32 (Figure 2-35). These wells are likely to be located within ¼ to ½ mile of the injection well. These wells are described in Table 2-5.

Table 2-5: Description of nearest potable water wells in Section 32, T17N, R3E

| API # | Well Owner | Well Depth (ft) | Well Diameter (in) | Year Drilled |
|--------------|-------------|-----------------|--------------------|--------------|
| 121152203900 | Gary Sebens | 55 | 36 | 1988 |
| 121152221200 | Gary Sebens | 38 | 36 | 1990 |
| 121152283500 | Anna Stiles | 56 | 36 | 1992 |

2.7.2.5 Distance to Nearest Downgradient Water Supply Well

The wells described above are likely to be the closest wells downgradient from the injection well. Shallow groundwater likely flows to the south and east, which is the same direction that the land surface slopes (toward Lake Decatur).

2.8 Minerals and Hydrocarbons

2.8.1 Mineral or Natural Resources beneath or within 5 miles of the Site

2.8.1.1 Stone, Sand, Clay and Gravel

Sand and gravel resources are commonly present in the low terraces and floodplain of the Sangamon River and its tributaries. Several sand and gravel pits have operated in the area in the past and currently there are one active and two idle operations in or near the project area. The nearest active sand and gravel pit is approximately 12 miles to the west-southwest of the ADM site. Relatively thick limestone deposits, suitable for construction aggregates, generally occur at depths greater than 1,100 feet. Access to these limestones is possible only through underground mining methods, which is not economically feasible at the present time.

Source:

Hester, N.C., 1969. Sand and gravel resources of Macon County, Illinois: Illinois State Geological Survey Circular 446, 16 p.

Lamar, J.E., 1964. Subsurface limestone resources in Macon County: Illinois State Geological Survey Unpublished Manuscript 141

2.8.1.2 Coal

The nearest active coal mines are the Viper Mine (about 35 miles west-northwest in Logan County) and Crown III Mine (operated by Springfield Coal Company, about 65 miles southwest in Macoupin County).

The nearest historical coal mining on record at the ISGS were the three mines in Decatur. The closest is within 5 miles of the proposed site, the Decatur No. 1 Mine. The shaft for this mine was northeast of the intersection of Eldorado and Jefferson Streets in Decatur (about 3 miles southwest of the site), and was about 600 feet deep. This longwall mine has no surviving map of the workings, but the main haulage entry was shown on the adjacent mine map, Macon County No. 2 Mine, which was connected underground. The Decatur No. 1 Mine operated from 1879

until 1914. The reported production was 1,780,000 tons, which would have undermined about 475 acres. The adjacent Macon County No. 2 Mine produced 2,660,000 tons, and undermined 430 acres. The portions of the only surviving map indicate that these mines operated west of Illinois Route 47/121. The third mine in Decatur is farther southwest, near the intersection of US Route 51 and Cantrell Street in Decatur. The Macon County No. 1 Mine operated from 1903 until 1947 and produced 4,590,000 tons. This production undermined over 670 acres. All of these mines recovered the Springfield Coal, which is between 4.0 and 5.0 feet thick in this area.

The presence of other unlocated or unrecorded old coal mines is unlikely. The first recorded coal exploration was in 1875, but coal was not found until 1876, on the third test hole. The great depth to the coal prevented small operators from opening the local mines that prevailed in many other counties.

Source:

Chenoweth, C., and A. Louchios, 2004. Directory of Coal Mines in Illinois, 7.5-minute Quadrangle Series: Decatur Quadrangle, Macon County, Illinois. Illinois State Geological Survey, 12 p., with “Coal Mines in Illinois – Decatur Quadrangle, Macon County, Illinois”, Illinois State Geological Survey Maps (1:24,000).

Illinois State Geological Survey, 2006. Directory of Coal Mines in Illinois, Logan County, 10 p.

Illinois State Geological Survey, 2006. Directory of Coal Mines in Illinois, Macoupin County, 17 p.

Existing Mineral Resources Near IL-ICCS Site location: Sec 32, T 17N, R E

A review of the known coal geology within a five mile radius of the proposed drilling site indicates that although several high-sulfur coals are present throughout the area, only the Springfield coal has a thickness of between 42 and 66 inches, which is considered mineable. Mining is restricted today due to urbanization and commercial development at the surface.

This restriction extends to five miles in all directions except to the north, north-east and east, where the coal is technically “available” for mining. “Available” coal means that the coal is not known to have geological, technological or land-use restrictions that would negatively impact the economics or safety of mining. These resources are not necessarily economically mineable at the present time, but they are expected to have mining conditions comparable with those currently being mined in the state. The top of the Springfield coal in the CCS #1 well is at a depth of 647 feet and its thickness, based on geophysical log analysis, is about 4 to 5 feet thick. In general, the coal bed dips gently eastward as the depth of the coal ranges from 500 feet five miles west of the site, to 725 feet five miles east of the site. Price, depth and coal thickness are inter-related economic factors that determine if coal might be mined in the future. Prior to 1947, there was mining in this seam farther than 3 miles to the southwest, where it is thicker.

Source: ISGS County Coal Map Data, Macon County, Illinois: available on the ISGS Coal Section website at: <http://www.isgs.uiuc.edu/maps-data-pub/coal-maps/counties/macon.shtml>

Treworgy, C., C. Korose, C. Chenoweth, and D. North, 2000. Availability of the Springfield Coal for Mining in Illinois, Illinois State Geological Survey, Illinois Minerals 118.

2.8.1.3 Oil and Gas

Oil and natural gas have been produced from both oil fields and solitary wells in the area of interest. The largest of these oil fields is the Forsyth Field, part of which is northwest of the IL-ICCS Site (Figure 2-35). The field produces from Silurian strata between depths of about of 2,070 and 2,200 feet. The producing zone is usually about 10 feet thick, but zones up to 60 feet thick have been recorded. In 2008, 6,100 barrels (bbls) of oil were produced from 48 producing wells. The total production for the field is 650,100 bbls of oil, as of the end of 2008.

The next nearest oil field in the area of interest is the Oakley Field, the western edge of which is located about 3.5 miles east from the ADM ICCS Site. The field produces from Devonian strata between depths of about of 2,255 and 2,310 feet. The producing zone is usually about 5 to 25 feet thick. In 2008, 1,200 bbls of oil were produced from 2 producing wells. The total production for the field is 43,100 bbls of oil, as of the end of 2008.

The third oil field in the area of interest is the Decatur Field, the eastern edge of which is located less than 6 miles west of the ADM ICCS Site. The field produces from Silurian strata between depths of about of 2,000 and 2,500 feet. The producing zone is usually about 10 to 20 feet thick. In 2008, 400 bbls of oil were produced from 9 producing wells. The total production for the field is 49,900 bbls of oil, as of the end of 2008.

In addition, there is a single oil well “field,” Decatur North, located about 1 mile north of the proposed injection well site. The well produced 125 barrels from Silurian strata at a depth of 2,220 to 2,224 feet. This well was plugged in late 1954 after eight months of production.

There is also a single production well, now plugged, that is located about 2 miles to the west of the ADM ICCS Site. The well was drilled in 1984 and abandoned in 1993. The well production was from Silurian strata at depths of about 2,040 to 2,050 feet. The total production for the well is about 2,200 bbls.

Natural gas is produced from several wells in the area that were drilled primarily for water. The gas is produced from Pleistocene sediments at depths of about 80 to 110 feet deep. The gas is suitable for domestic or agricultural usage but not for commercial development as a natural gas field.

Source:

Various years, Illinois Annual Oil Field Reports, Illinois State Geological Survey.

ISGS ILWATER database available at: <http://www.isgs.uiuc.edu/maps-data-pub/wwdb/launchims.shtml>

2.9 References cited in the figures

Bond, D.C., 1972. Hydrodynamics in deep aquifer of the Illinois Basin, Illinois State Geological Survey Circular 470, Urbana, IL, 72 p.

Byers, D., 2011. Personal communication, Illinois State Geological Survey.

Finley, R., 2005. An Assessment of Geological Carbon Sequestration Options in the Illinois Basin: Final Report to the United States Department of Energy, Contract: DE-FC26-03NT41994, 581p. Finley, Robert, Principal Investigator, December 31, 2005.

Frommelt, D., 2010. Letter to the Illinois Environmental Protection Agency, Subject: CCS Well #1 Completion Report, Archer Daniels Midland Company – UIC Permit UIC-012-ADM, dated May 5, 2010.

Gupta, N. and E.S. Bair, 1997. Variable-density flow in the midcontinent basins and arches region of the United States, *Water Resources Research*, 33(8): 1785-1802.

Leetaru, H., 2011. Personal communication, Illinois State Geological Survey.

Kolata, D.R., 2005. Bedrock Geology of Illinois, Illinois State Geological Survey Illinois Map 14: 1:500,000.

Larson, D.R., B.L. Herzog and T.H. Larson, 2003. Groundwater Geology of DeWitt, Piatt, and Northern Macon Counties, Illinois. Champaign, IL, Illinois State Geological Survey *Environmental Geology* 155: 35.

Loyd, O.B. and W.L. Lyke, 1995. Ground Water Atlas of the United States, Segment 10: Illinois, Indiana, Kentucky, Ohio and Tennessee, United States Geological Survey Hydrologic Investigations Atlas 730-K, 30 p

Willman, H.B., E. Atherton, T.C. Buschbach, C. Collinson, J.C. Frye, M.E. Hopkins, J.A. Lineback, and J.A. Simon, 1975. Handbook of Illinois Stratigraphy, Illinois State Geological Survey Bulletin 95, 261 pp.

V. Smith, personal communication, Schlumberger Carbon Services, 2011

Figure 2-1: Regional structure map showing no regional structures within a 25-mile radius of the ADM Plant near Decatur, Macon County. Source: Illinois State Geological Survey.

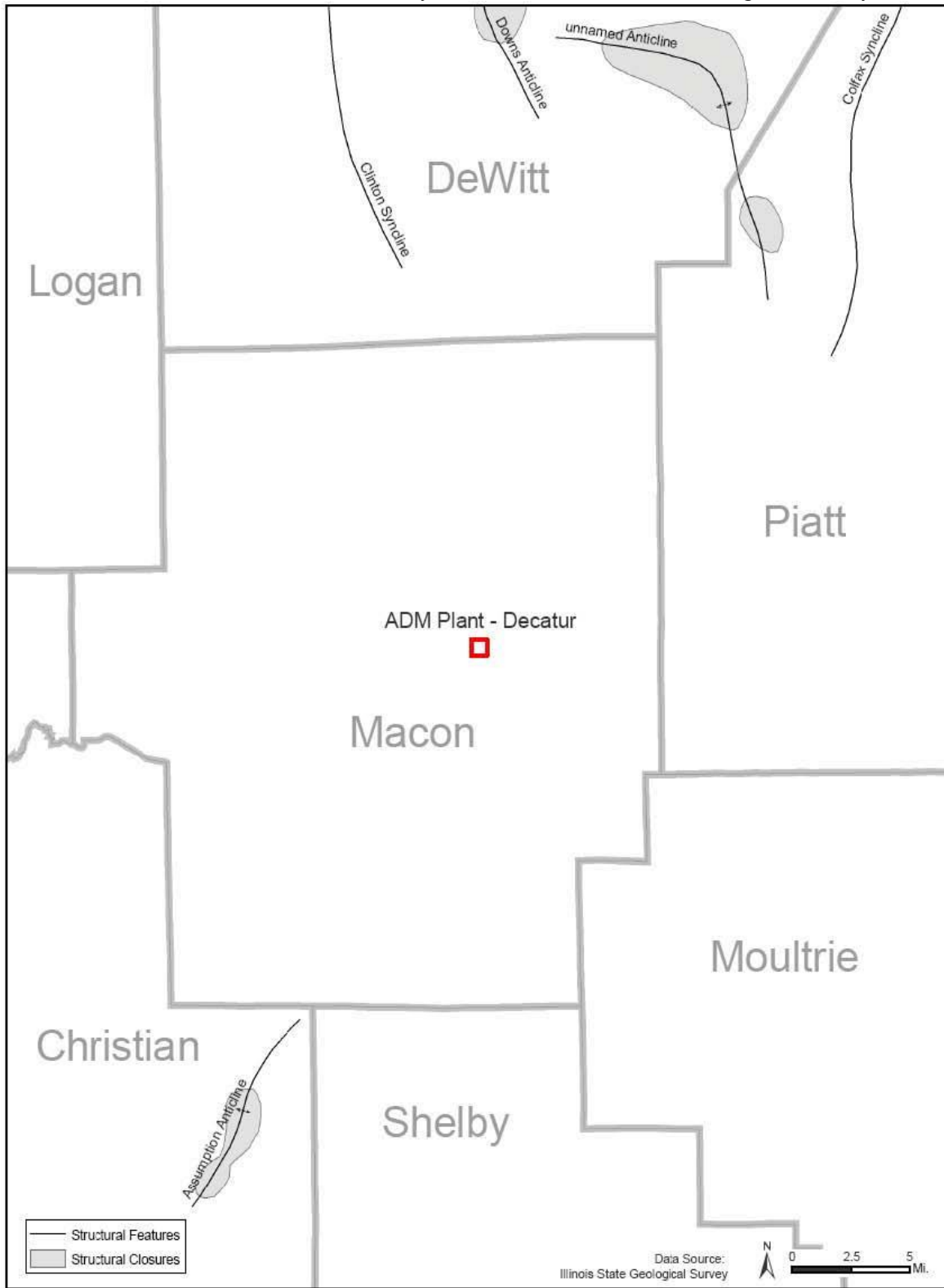

Figure 2-2: Aerial photo over the proposed injection site (IL-ICCS well location labeled). The yellow lines denote seismic lines that were recorded. Reference Figures 2-3 and 2-4 for corresponding geologic cross-sections. Source: Byers, ISGS, 2011

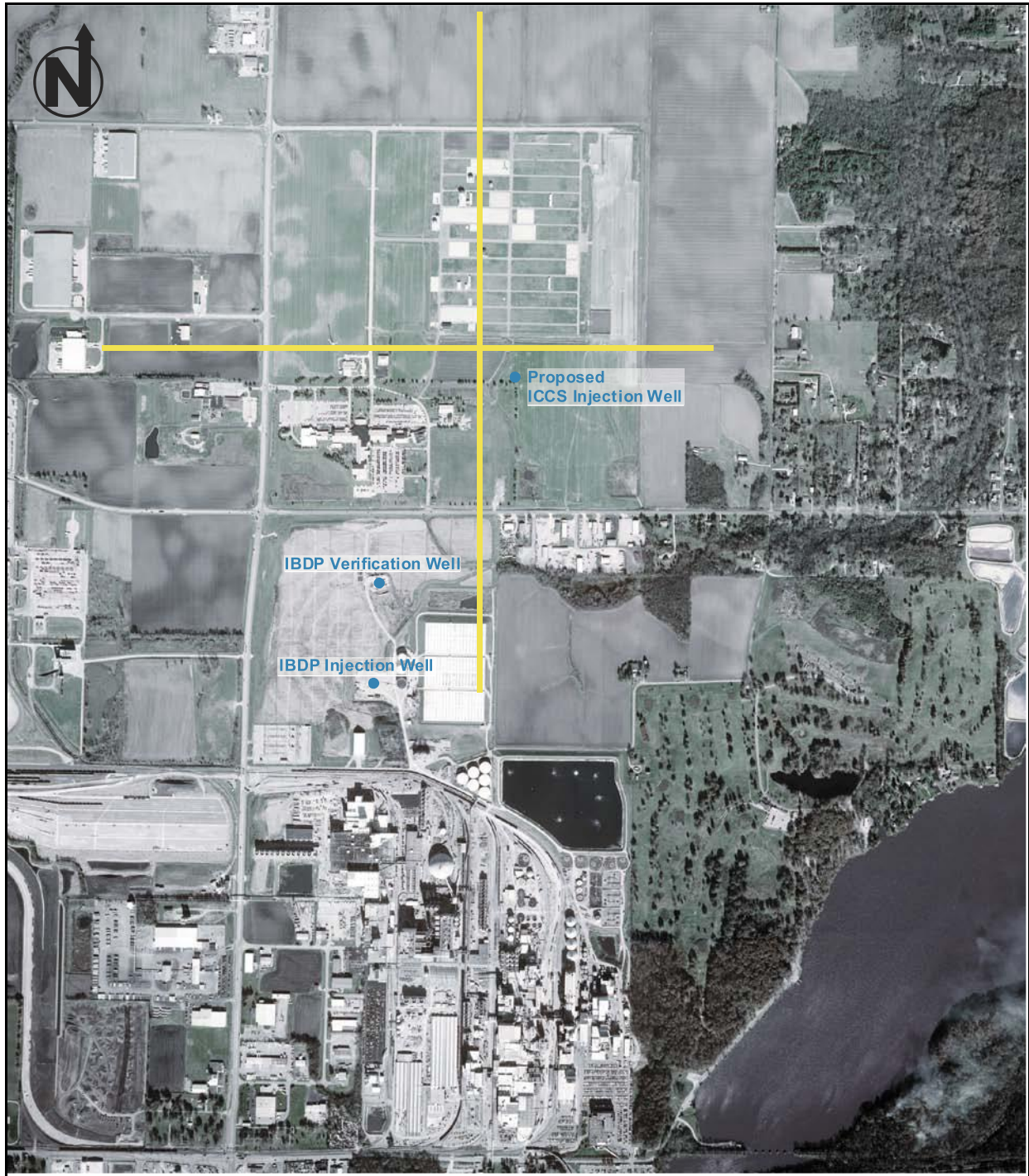

Figure 2-3: East-West seismic reflection profile along the proposed IL-ICCS injection site. Source: Leetaru, 2011

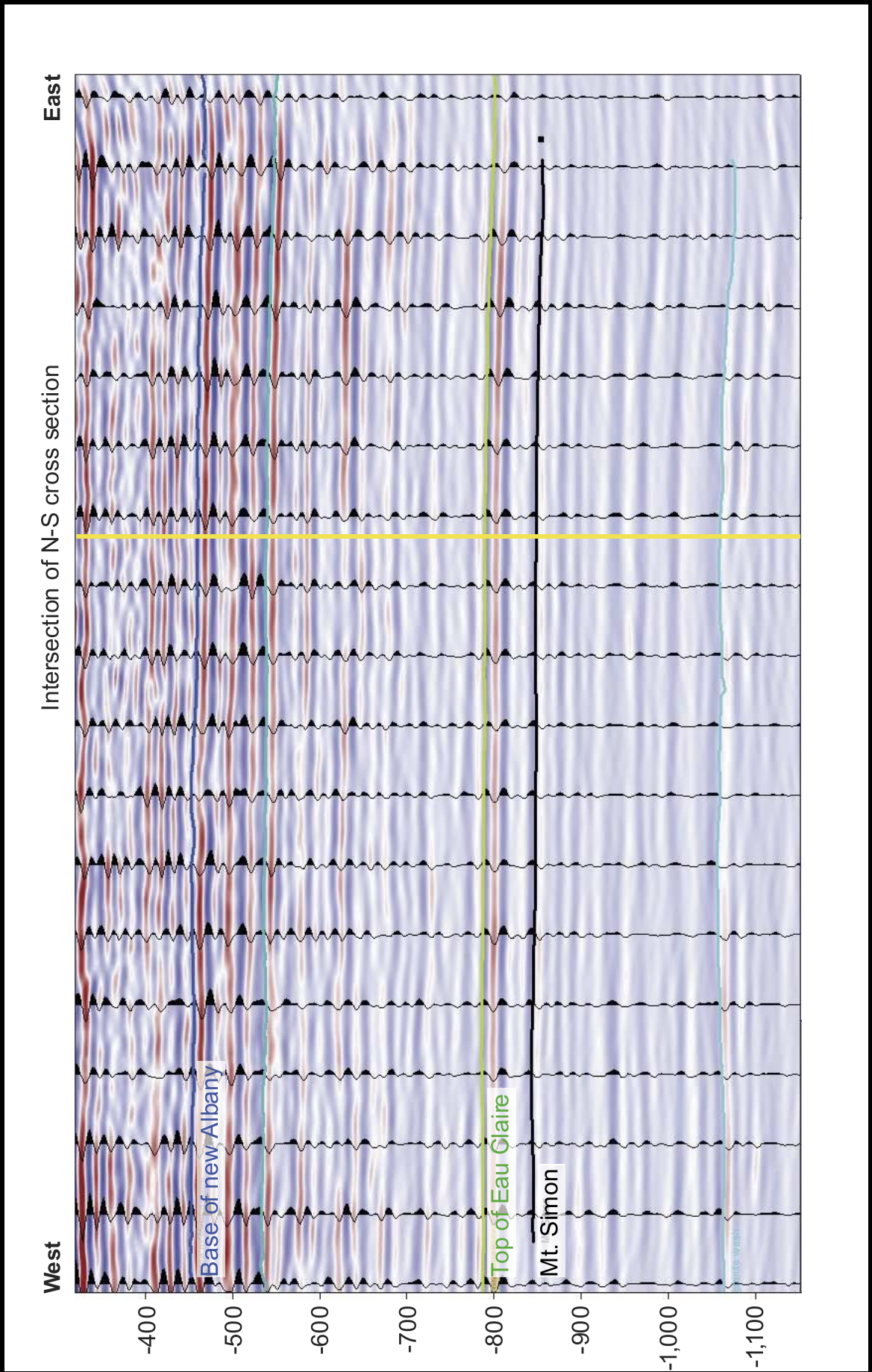

Figure 2-4: North-South seismic reflection profile along the proposed IL-ICCS injection site. Source: Leetaru, 2011

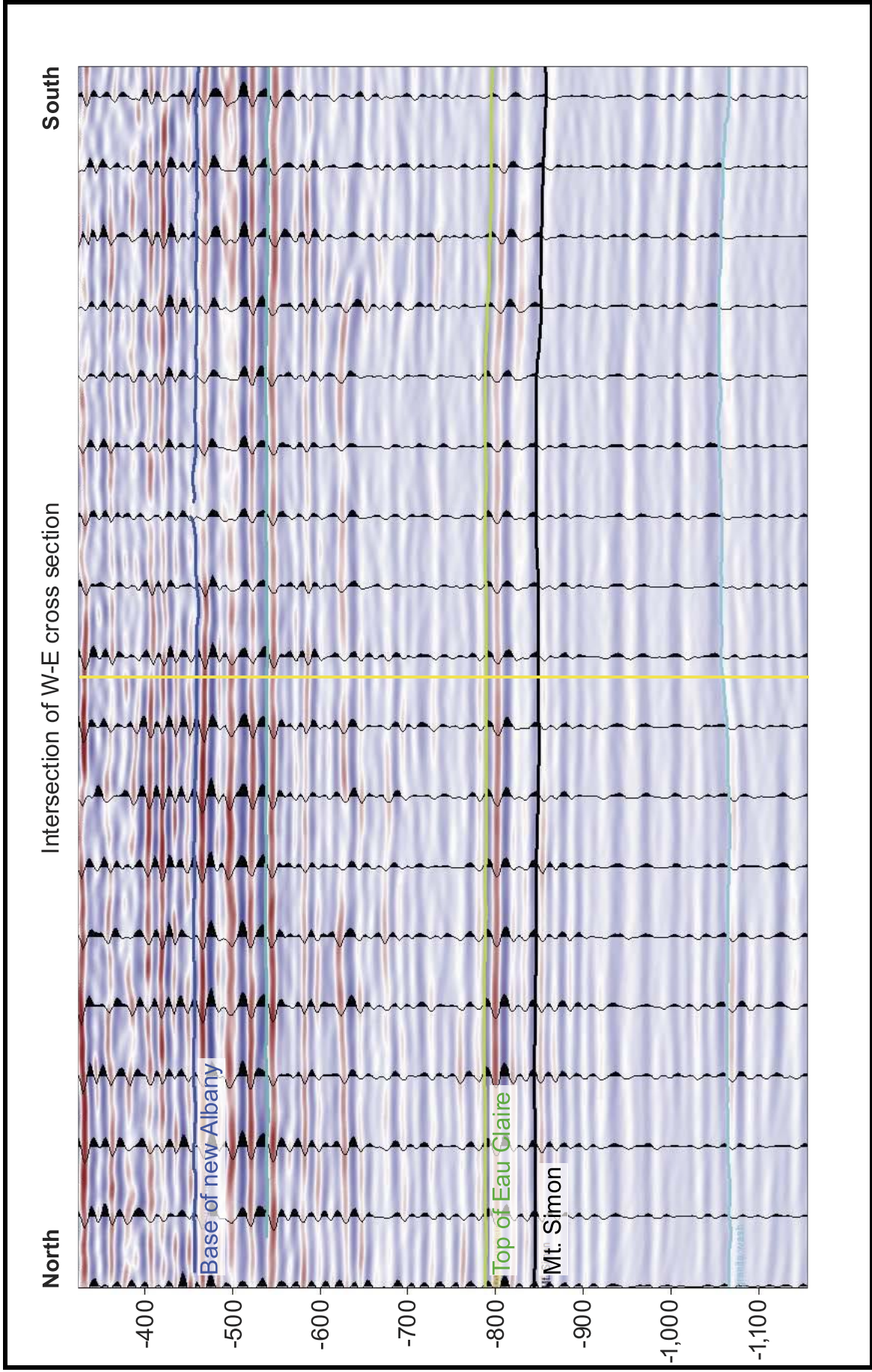

Figure 2-5: Location of cross-sections illustrating the regional geology of the injection site (Figure 2-6 and 2-7 are cross-sections referenced). Source: Smith, Schlumberger Carbon Services, 2011

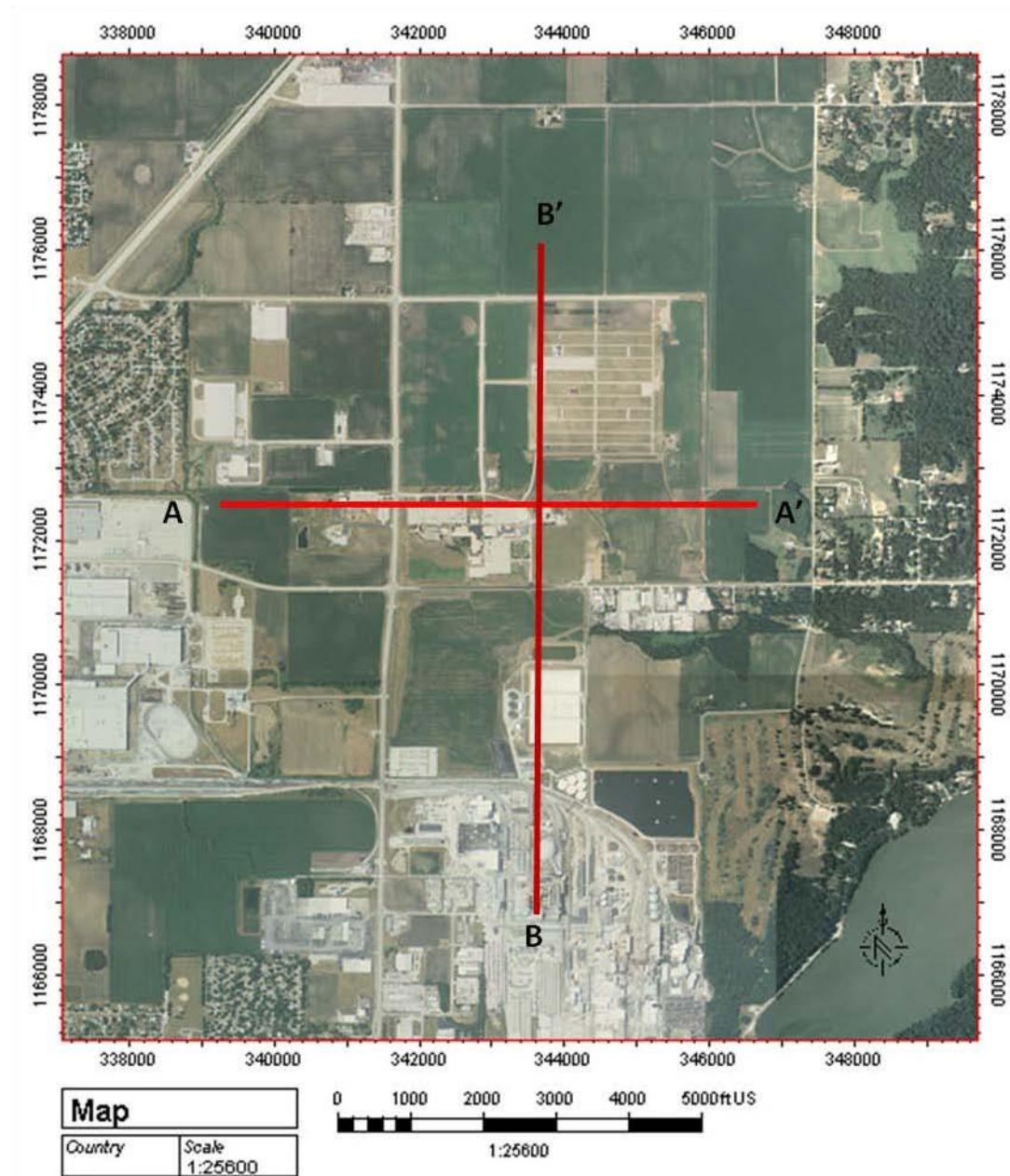

Figure 2-6: Cross section illustrating the geology along west (A) to east (A') direction (location given by Figure 2-5). Source: Smith, Schlumberger Carbon Services, 2011

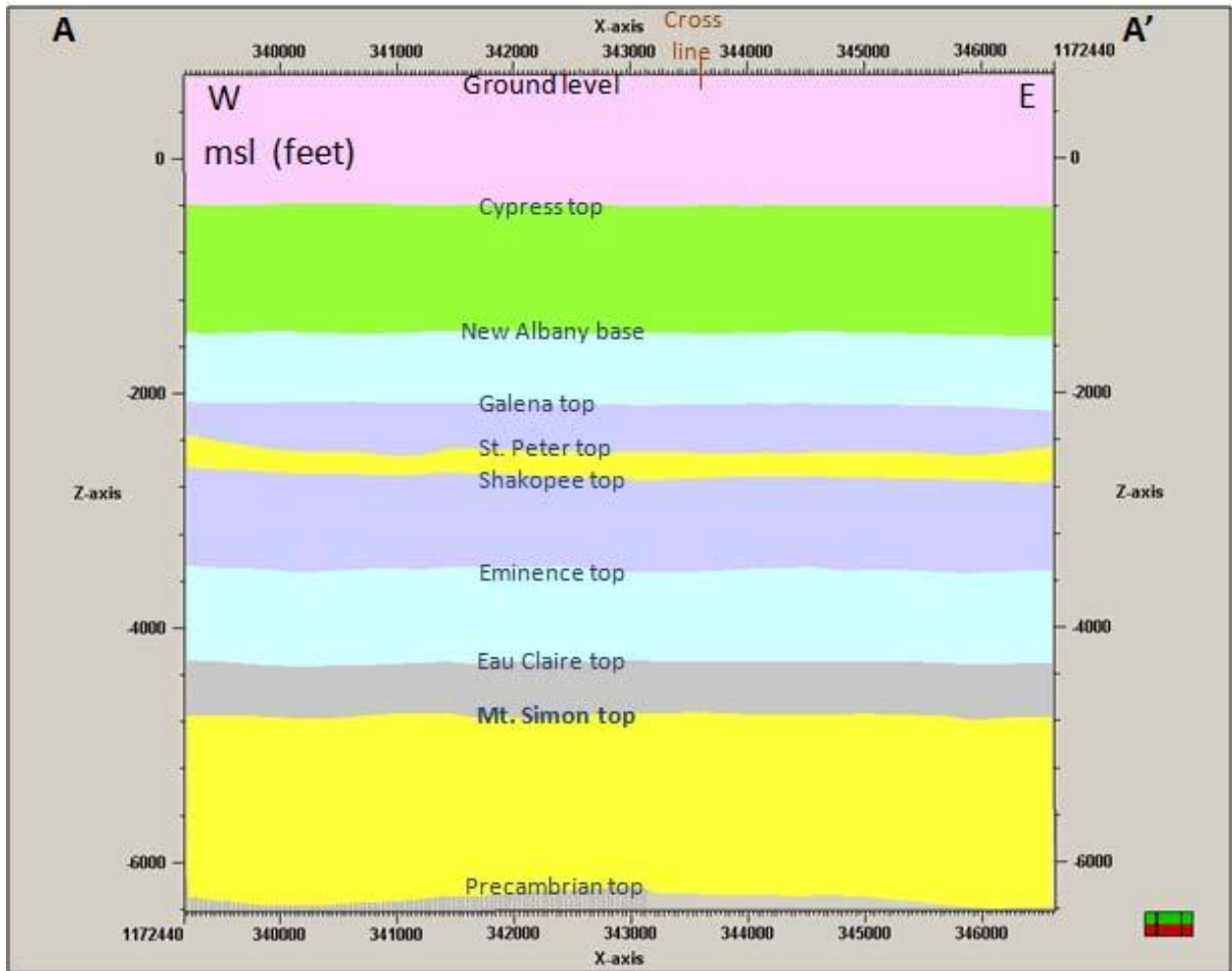

Figure 2-7: Cross section illustrating the geology along south (B) to north (B') direction (location given by Figure 2-5). Source: Smith, Schlumberger Carbon Services, 2011 .



Figure 2-8: Stratigraphic column of Ordovician through Precambrian rocks in northern Illinois (Kolata, 2005). Arrows point to the formations discussed in this UIC permit application. Dr, Darriwillian; Dol, dolomite; Fm, formation; Ls, limestone; MAYS., Maysvillian; Mbr, Member; Sh, shale; WH., Whiterockian; Mya, million years ago; Ss, sandstone; Silts, siltstone.

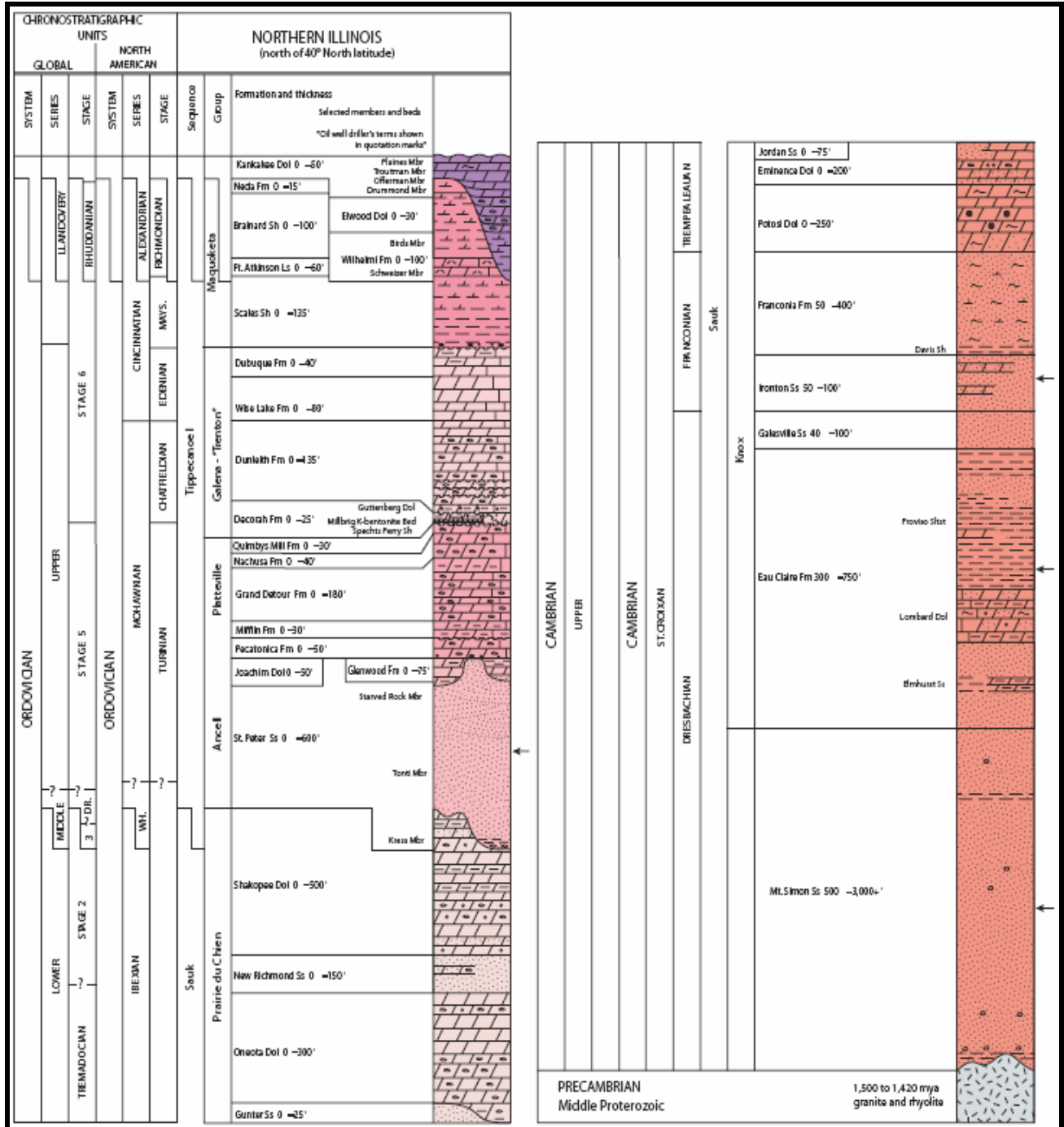

Figure 2-9: Stratigraphic cross section through the Weaber Horn #1, Harrison #1, CCS #1 and the Hinton #7 wells showing the Mt. Simon porosity. The red colored zones have porosity greater than 10% (Frommelt, 2010).

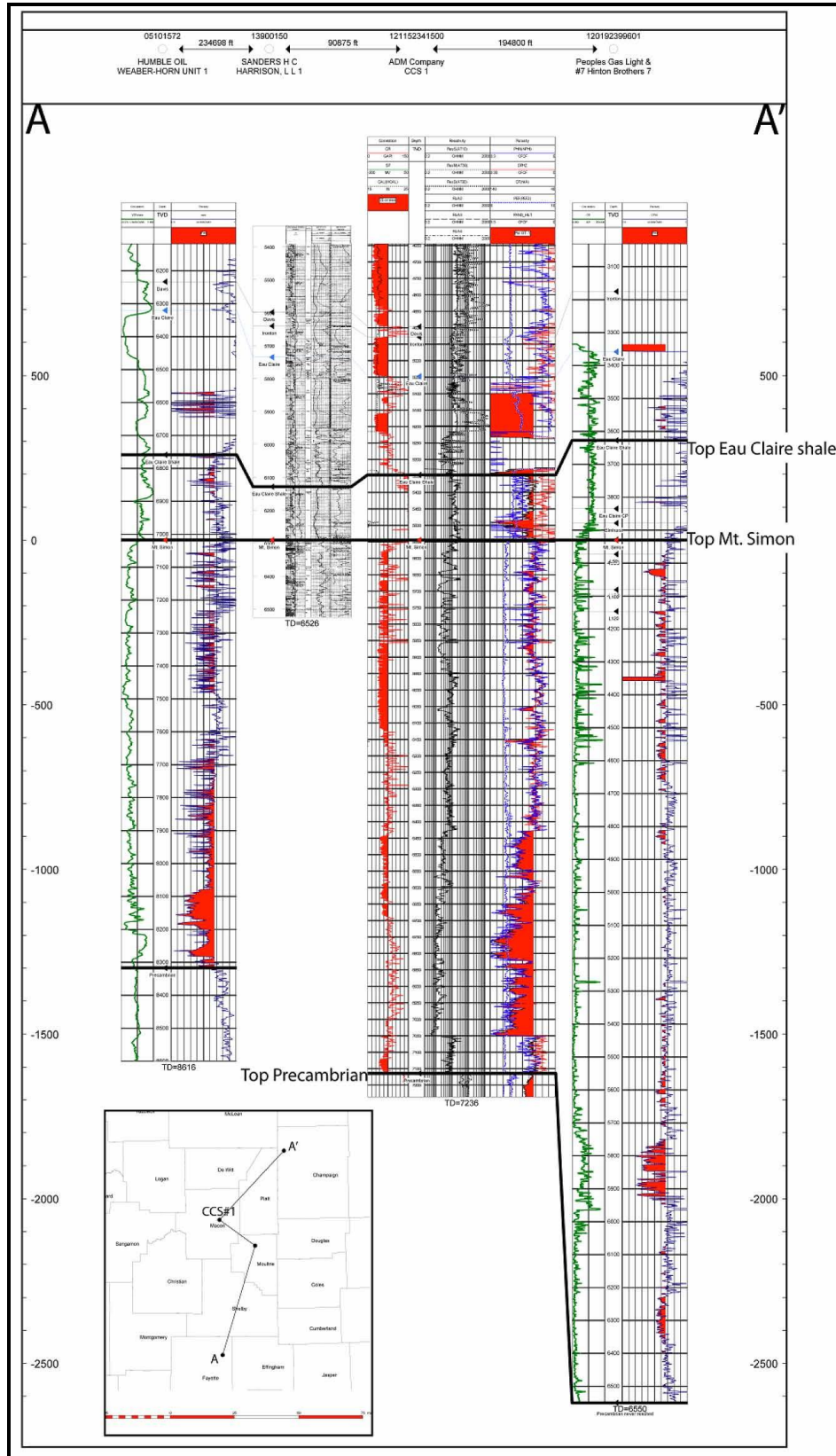

Figure 2-10: IBDP CCS #1 step-rate test with fracture propagation pressure of 4966 psig estimated from the intersection of the two lines. The first line (2-6 bpm) represents radial flow of the Mt. Simon; the second line 7-8 bpm represents flow into the Mt. Simon after a fracture has propagated. The perforated interval was 7,025 to 7,050 feet during this step-rate test. These results correspond to a fracture gradient of 0.715 psi/ft. Source: Frommelt, 2010.

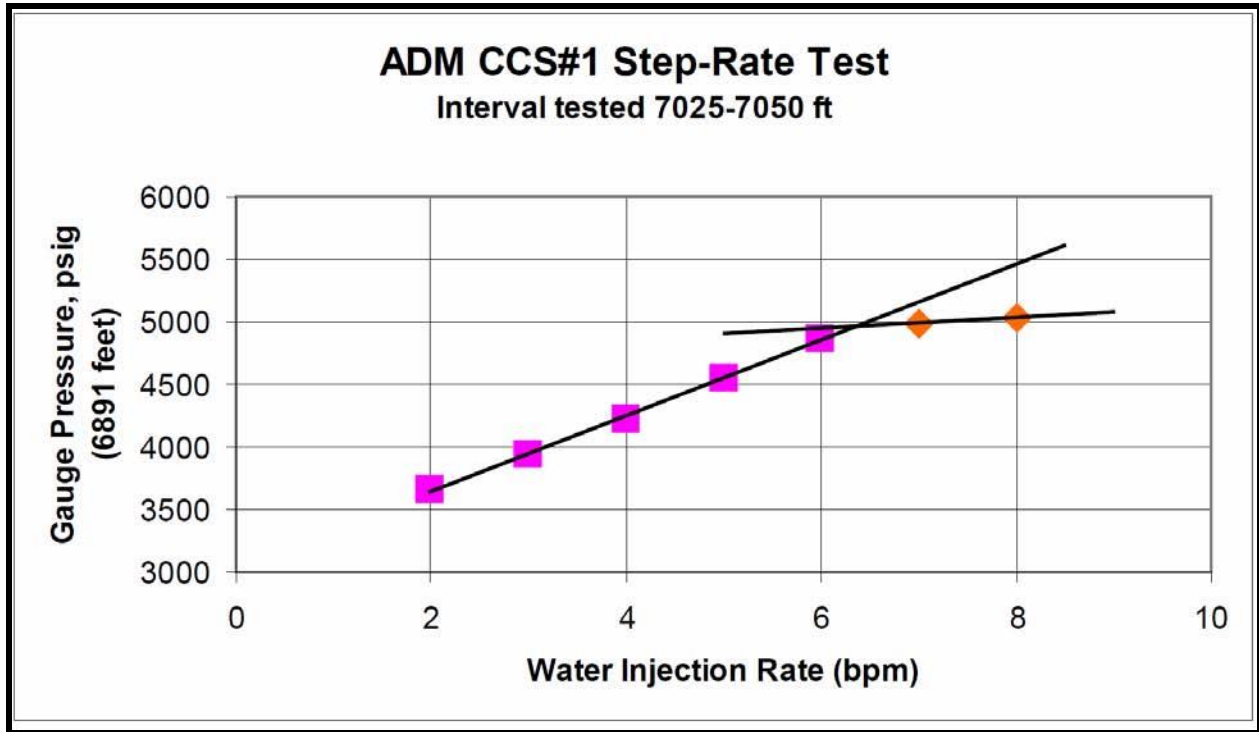

Figure 2-11: Crossplot of helium porosimeter and neutron-density data for CCS #1. The bold line through the data is the unit slope, showing very good correlation between the two types of porosity data. For the porosity data from the rotary sidewall core plugs and the neutron-density crossplot porosity at the interval of the core plug, the porosity compares relatively well such that total and effective porosity are very similar. Source: Frommelt, 2010.

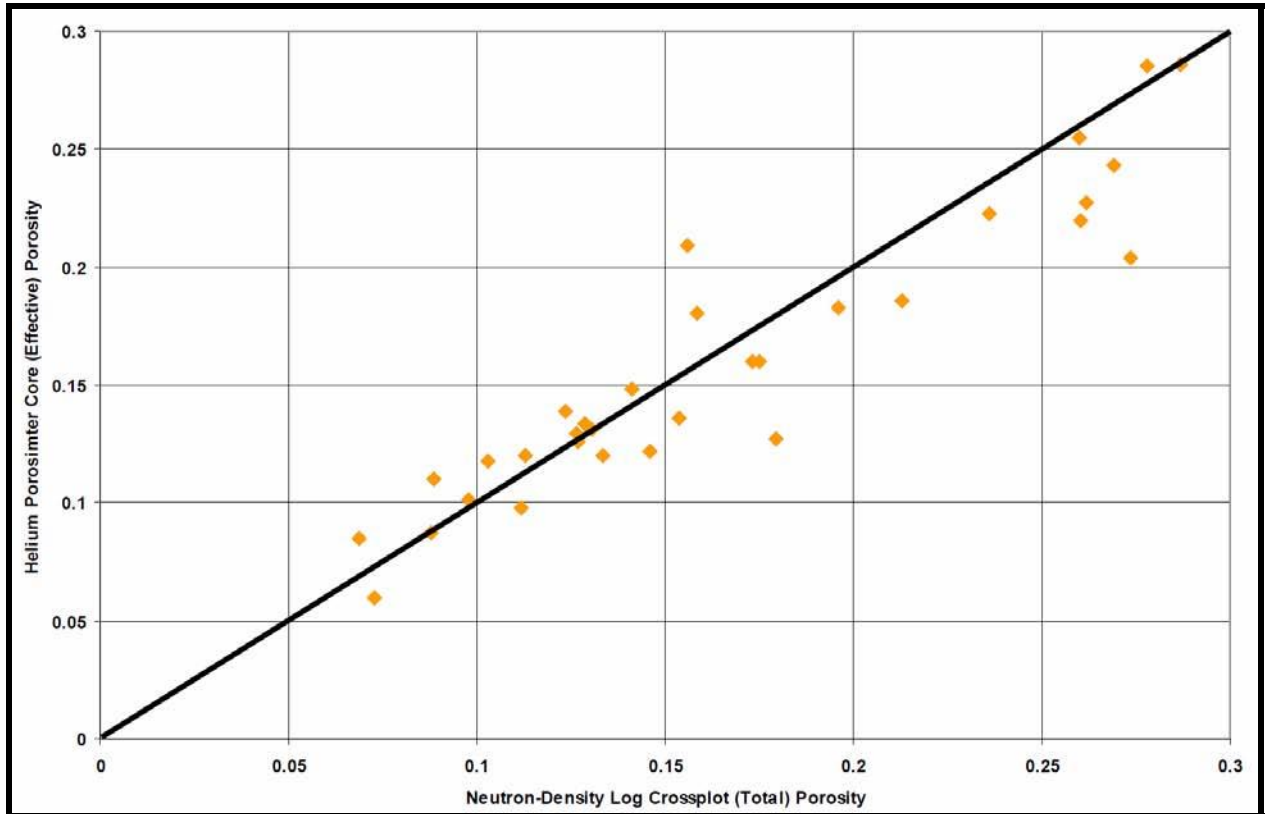

Figure 2-12. Crossplot of core permeability versus core porosity for CCS #1. Transforms were developed for three different grain sizes—fine grained, medium grained and coarse grained sandstone. Source: Frommelt, 2010.

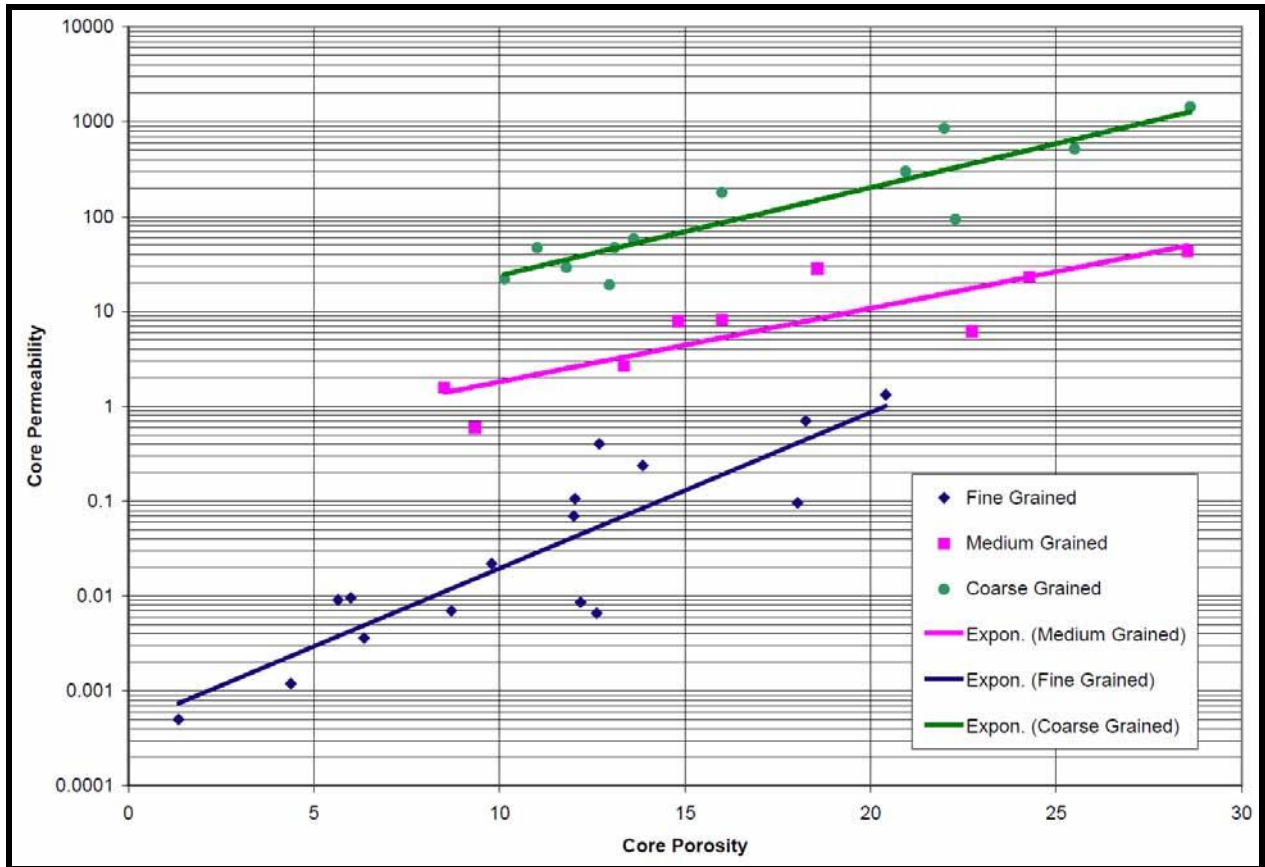

Figure 2-13: Qualitative derivative analyses of final pressure falloff test conducted in CCS #1. Radial pressure response is indicated by a horizontal derivative trend. Two periods were measured during this test between 0.1 and 1 hours (PPNSTB) and 20 to 100 hours (STABIL). The first period corresponds to radial flow across the perforated interval; the second period corresponds to the larger thickness that would be between two much lower permeability sub-units e.g, the less permeable arkose-rich interval at the base and a tighter interval above the perforated interval. The transition between the two radial responses (SPHERE) is a spherical flow period that is influenced by vertical permeability (or k_v/k_h). (The unit slope (UNIT SLP) indicating wellbore storage, identifies the end of wellbore storage influenced pressure data (ENDWBS) or pressure data that can be analyzed from reservoir properties.). Source: Frommelt, 2010.

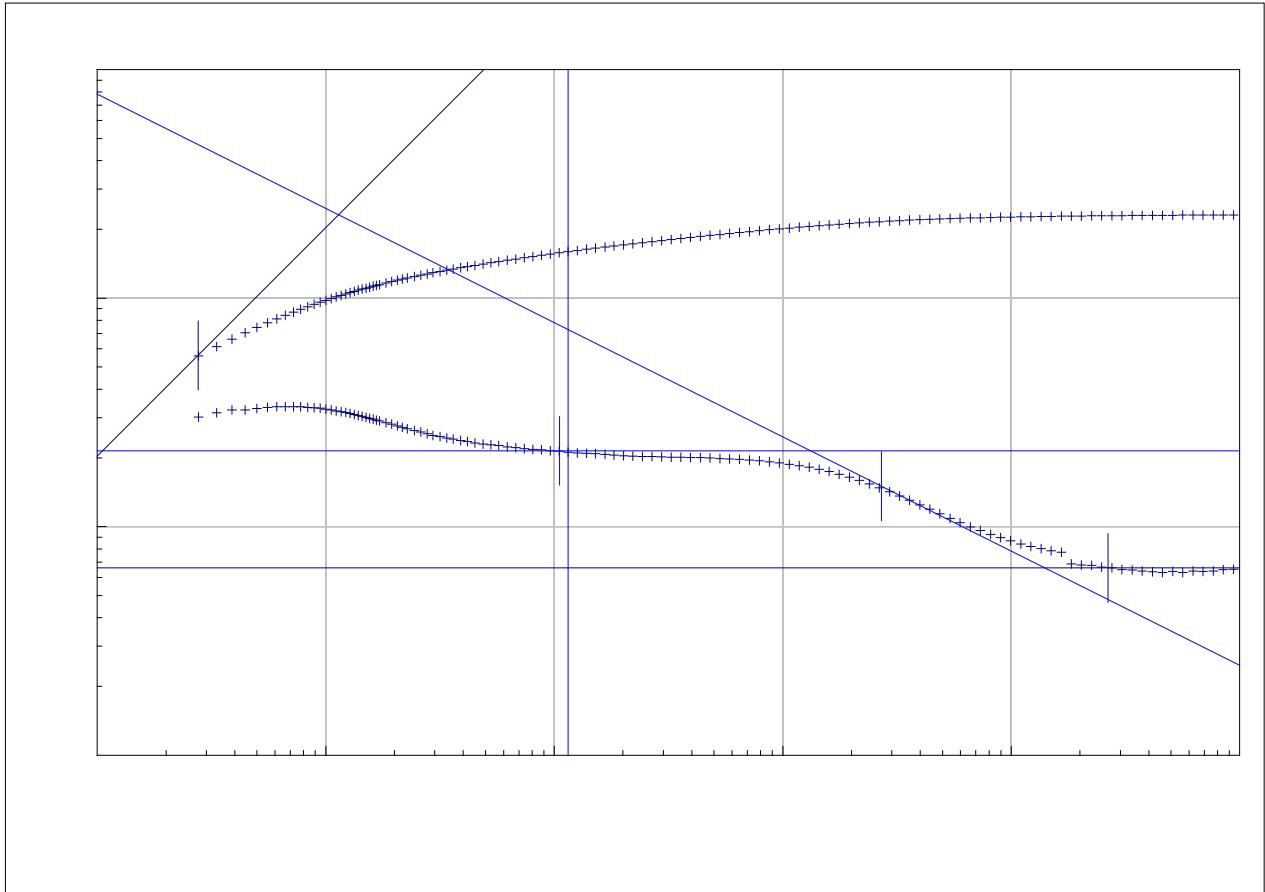

Figure 2-14: Overlay of pressure derivative of the three pressure falloff tests conducted in CCS #1. The Green curve (upper pressure curve and bell shaped derivative) is the first falloff which had perforated interval of 7025-7050 ft MD. The pink (lower derivative curve) is the second falloff in the same perforated interval which had a modest acid treatment prior to the falloff. The dark blue (lower pressure curve middle derivative curve) was the third falloff tests for the perforated intervals of 6982-7012 and 7025-7050 ft MD and a second acid treatment over both perforated intervals. The difference between the green curve and the pink curve in the first 6 minutes is a result of the improvement to flow due to the acid treatment. The upper curves show the pressure difference and the lower curves show the derivative. Source: Frommelt, 2010.

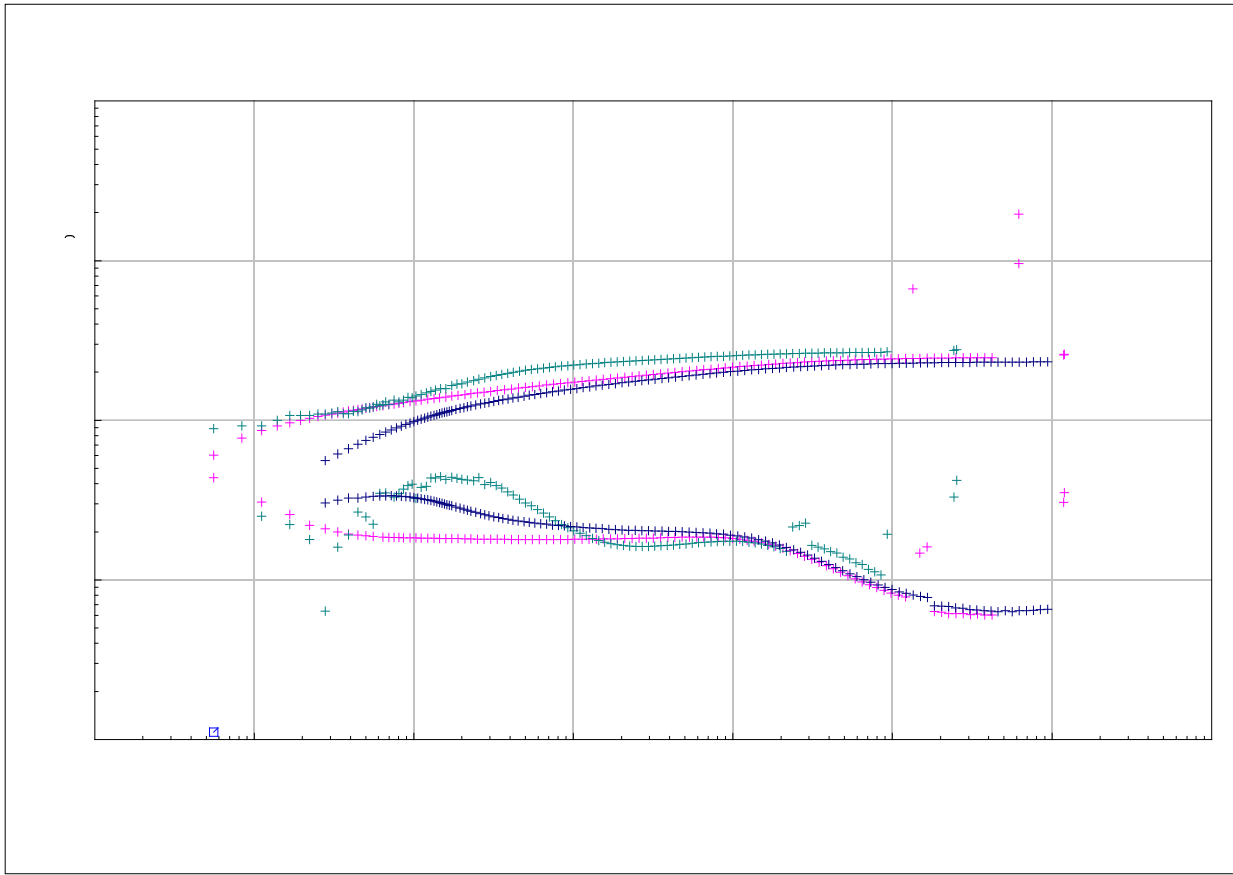
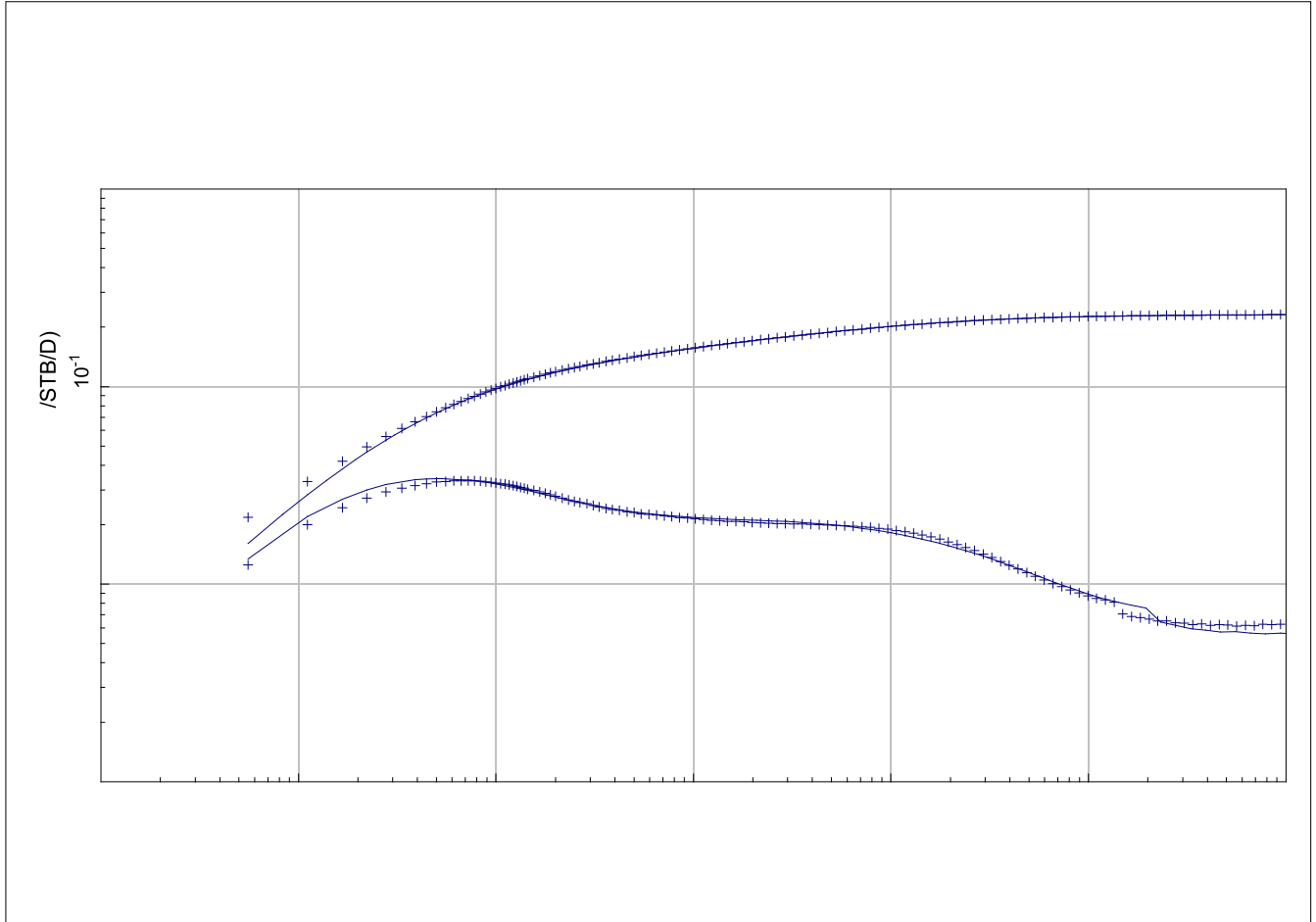

Figure 2-15: Nonlinear regression, or simulation history matching, of the of final pressure falloff test conducted in CCS #1. Test data shown as + symbols and simulated data shown as line. The upper curve is the pressure difference and the lower curve is the derivative. Source: Frommelt, 2010.



Partial Penetration Well

** Simulation Data **

well. storage = 0.0011457 BBLs/ PSI
 Skin(mech.) = -0.85807
 permeability = 184.58 MD
 Kv/ Kh = 0.013260
 Eff. Thickness = 75.000 FEET
 Zp/ Hef f = 0.83330
 Skin(Global) = 10.301
 Perm Thickness = 13843. MD- FEET

Type- Curve Model Static-Data
 Perf. Interval = 25.0 FEET

Static-Data and Constants
 Volume- Factor = 1.000 vol / vol
 Thickness = 75.00 FEET
 Viscosity = 1.300 CP
 Total Compress = .1800E-04 1/ PSI
 Rate = -6100. STB/ D

Figure 2-16: Observed head in the Mt. Simon sandstone. Groundwater flows from areas of higher head to lower head, along lines perpendicular to the head lines. Contour interval = 25 m. (modified from Gupta and Bair, 1997). At the CCS #1 well (red dot), the potentiometric surface was calculated to be 76 m above mean sea level.

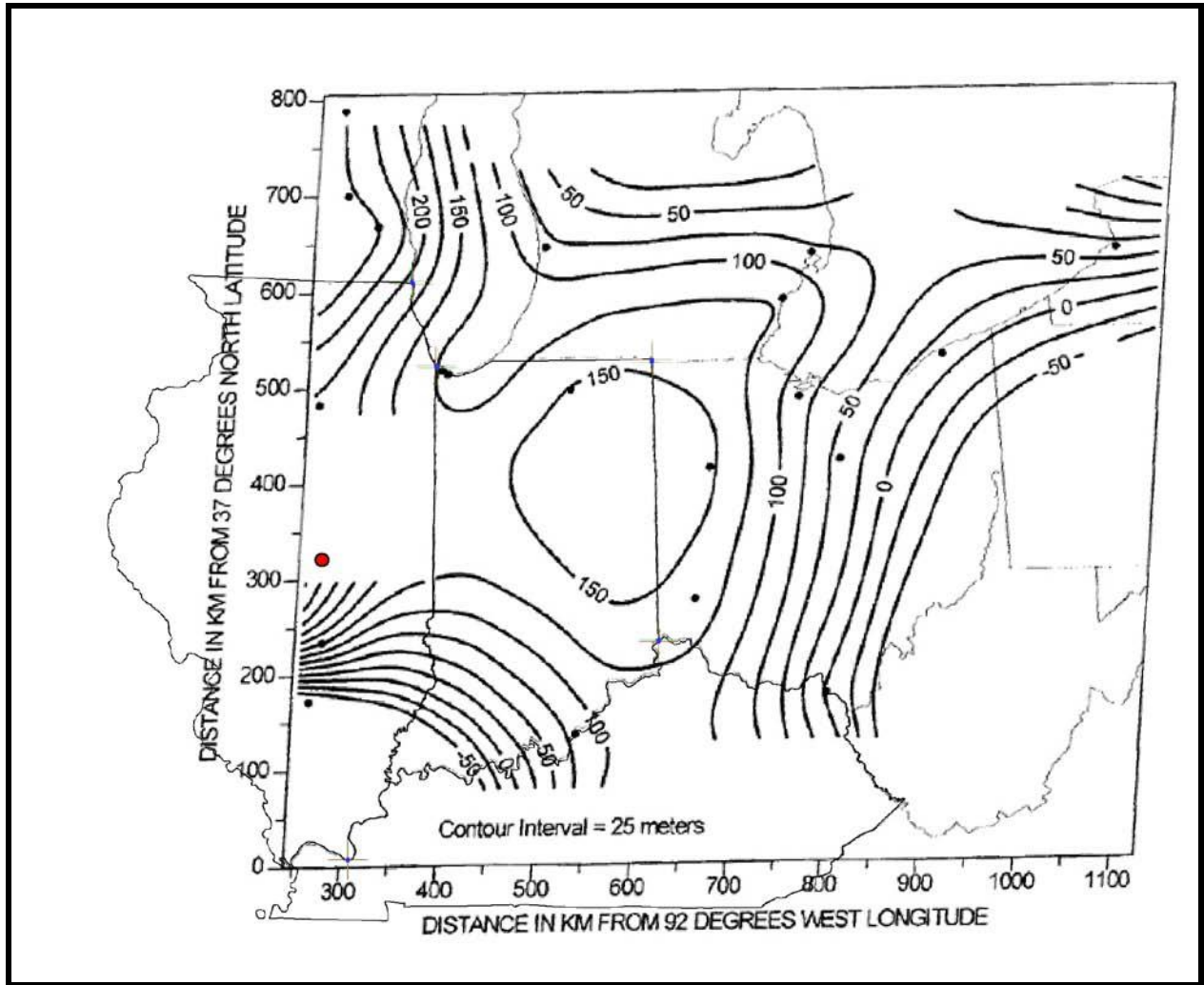

Figure 2-17: Observed vertical flow components in the Mt. Simon Sandstone around the Upper Midwest with the Michigan Basin based on Vugrinovich (1986), (from Gupta and Bair, 1997).

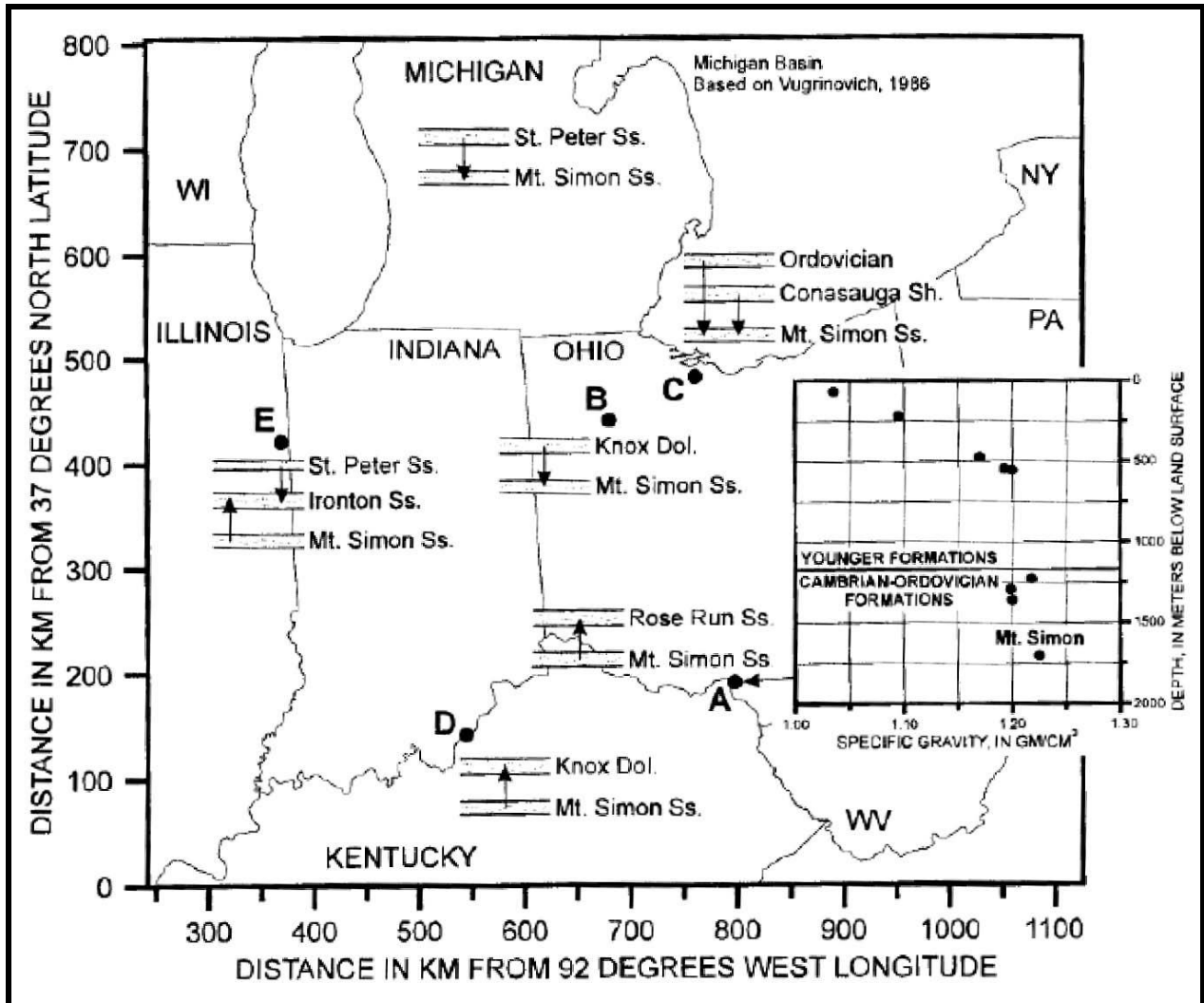

Figure 2-18: Relation between relative density and dissolved solids content of brines in deep aquifers of the Illinois Basin. Source: Bond (1972).

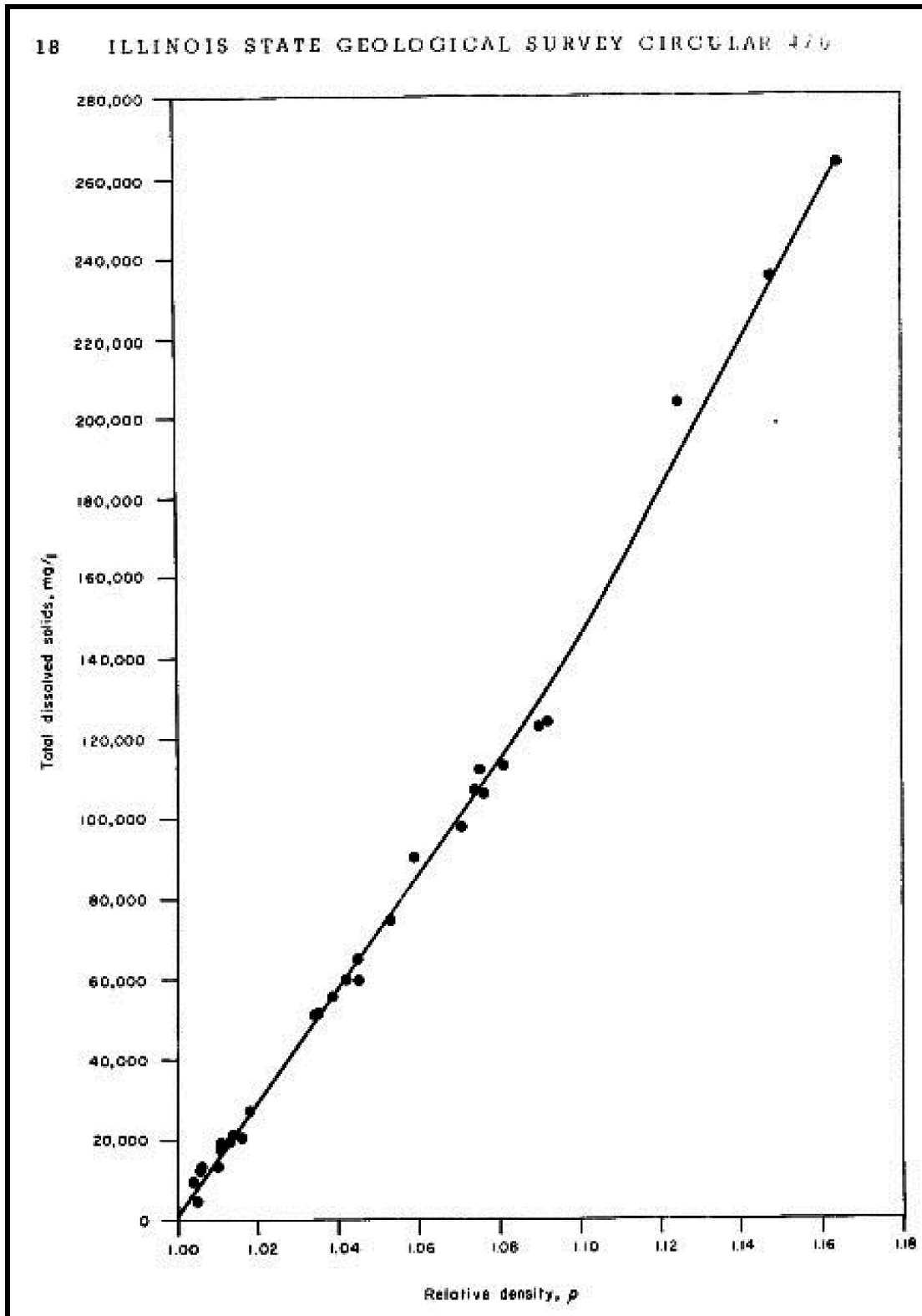

Figure 2-19: Total dissolved solids (TDS) within the formation water of the Mt. Simon Reservoir
Source: Modified from Finley, 2005.

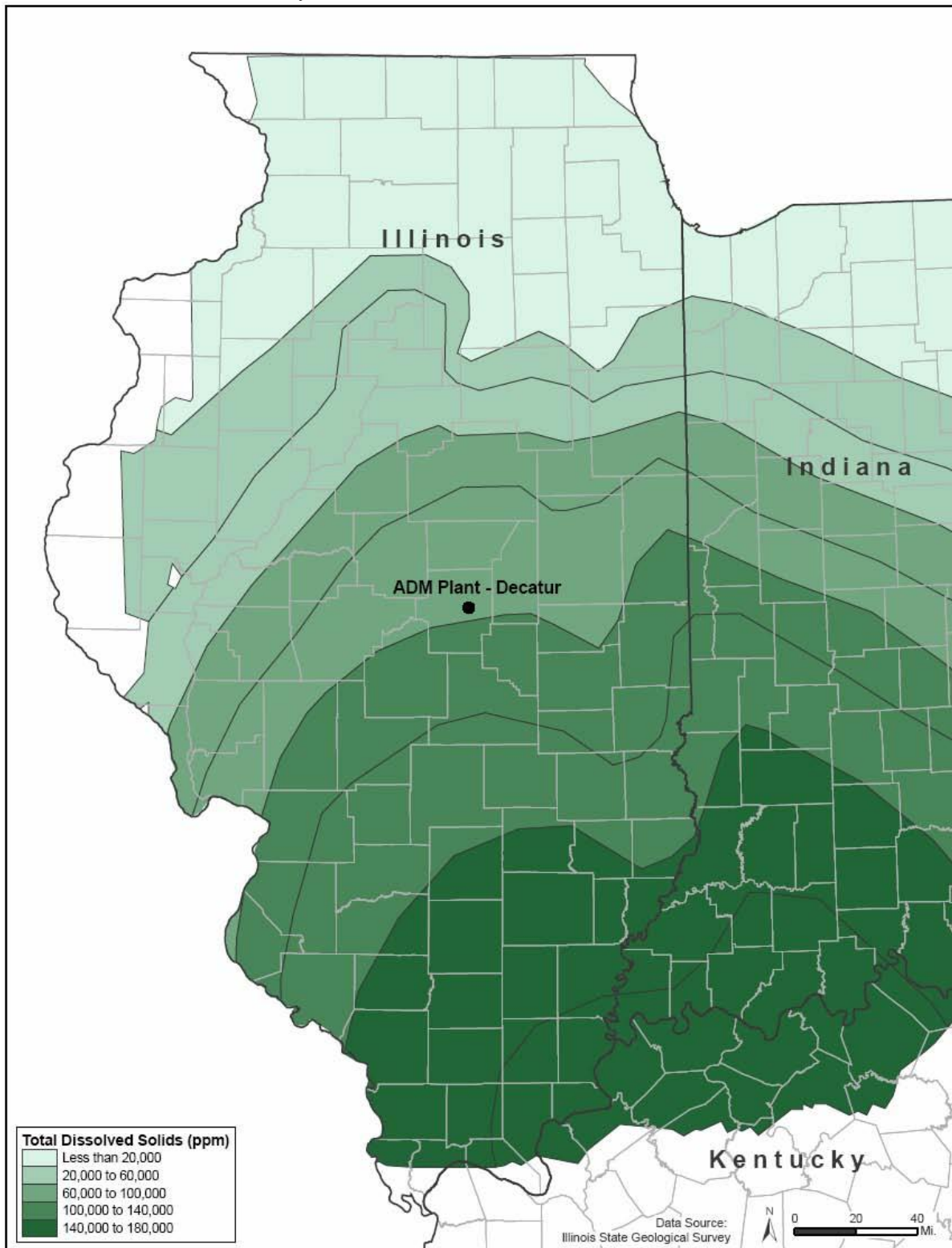

Figure 2-20: Diagrammatic cross section of the Cambrian System from northwestern to southeastern Illinois. The orange color shows the areas where the Eau Claire Formation is primarily shale and should be a good seal. Uncolored areas may behave as seals, but there is an enhanced risk for leakage because of fracturing (modified after Willman et. al., 1975).

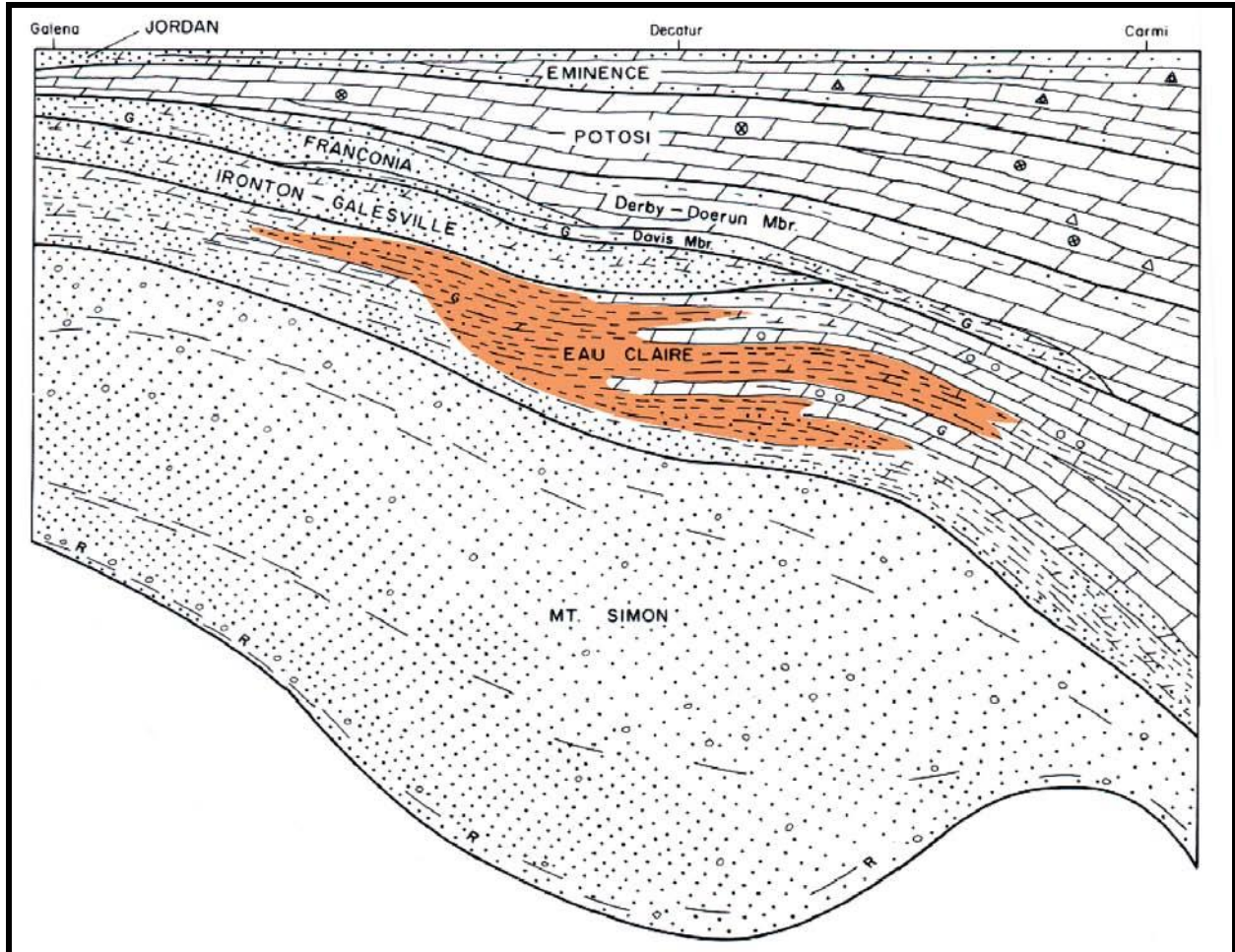

Figure 2-21: Thickness (feet) of the New Albany Shale.
 Proposed injection well is near the center of Section 32 (shaded purple). Source: Leetaru, 2007.

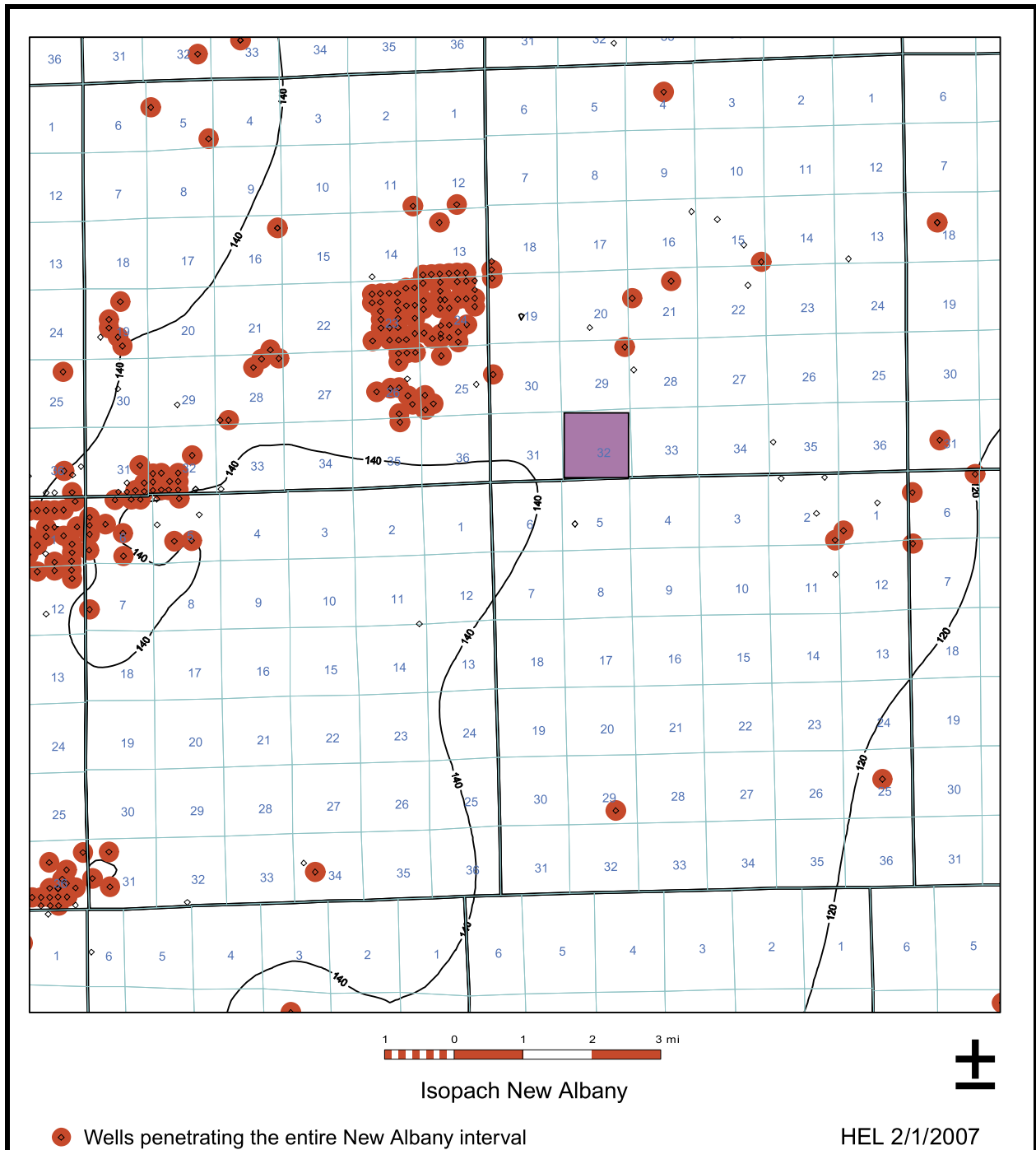

Figure 2-22: Isopach of the Ironton-Galesville Sandstone in Illinois. The orange line signifies the southern limit of the formation. There are no sandstone facies south of this line. (Willman, et al, 1975). The approximate site location is denoted by the red square.

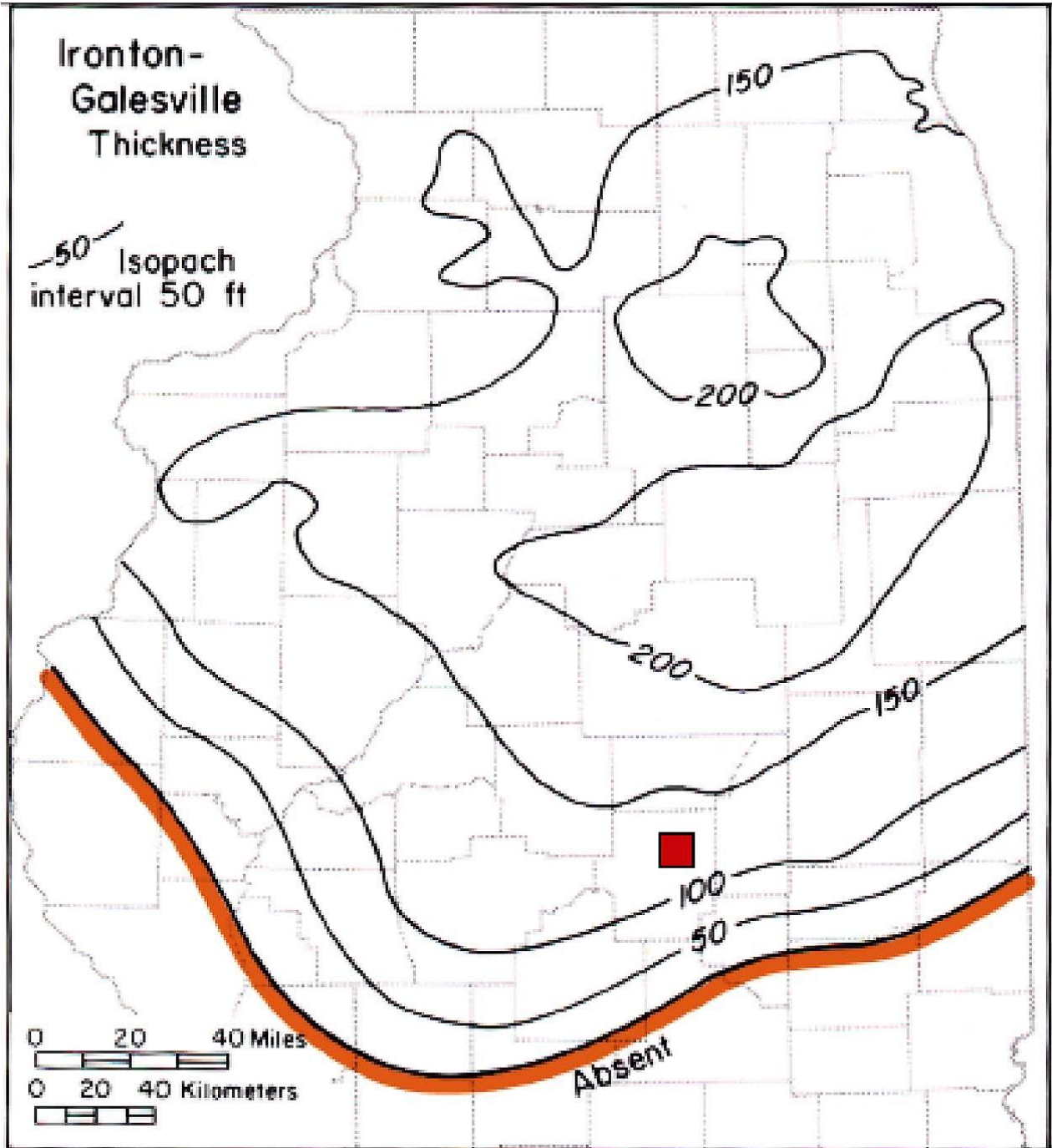

Figure 2-23: Regional map showing limits of fresh water in the Ironton-Galesville Sandstone. Proposed injection site should not encounter freshwater when drilling this formation. Source: Loyd, O.B. and W.L. Lyke, 1995, Ground Water Atlas of the United States, Segment 10: United States Geological Survey, 30 p. The red square denotes the relative location of the proposed injection site.

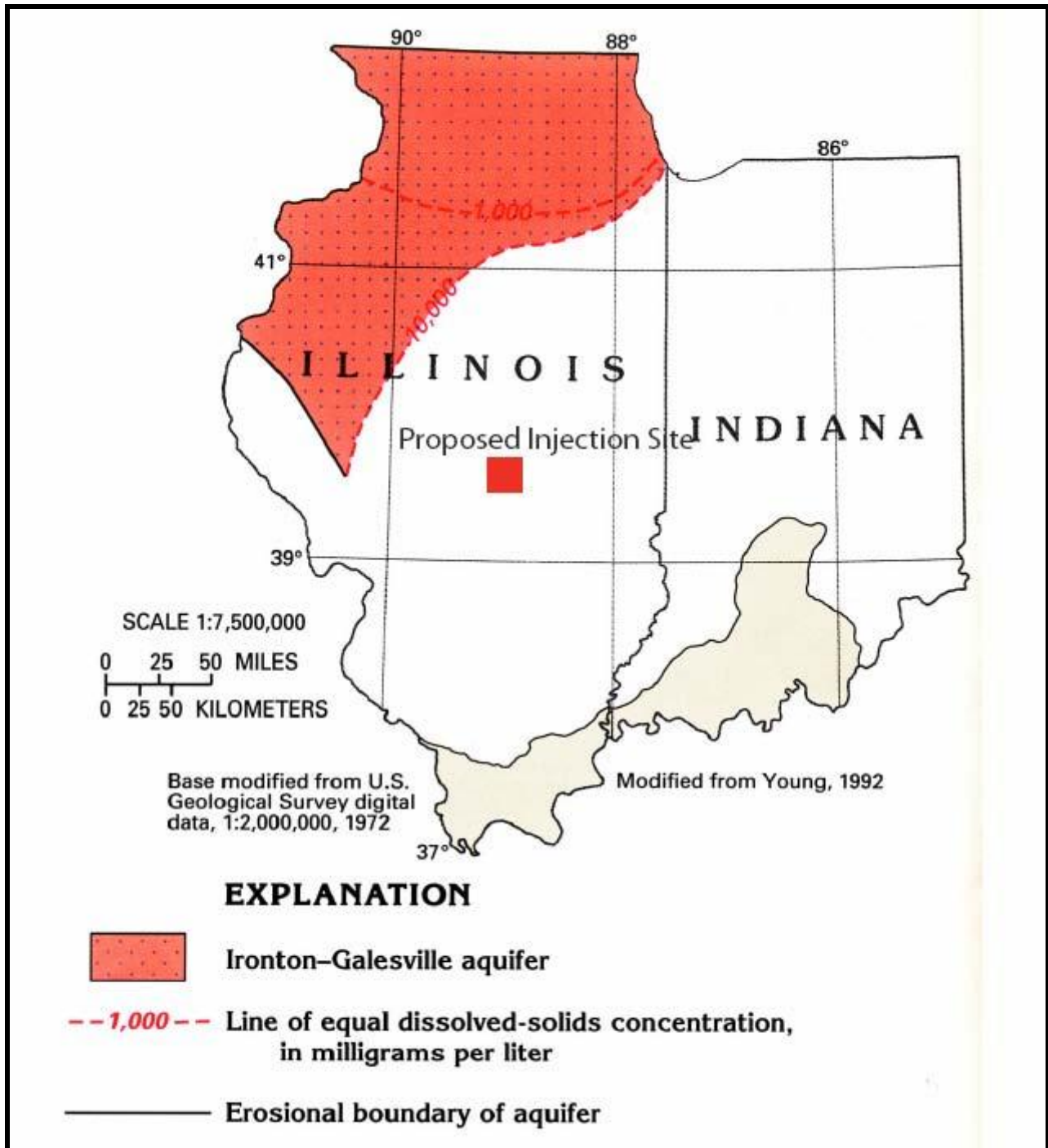

Figure 2-24: Regional Quaternary deposits near proposed IL-ICCS Injection Site, Decatur, IL.
 Source: ISGS Quaternary Deposits GIS Dataset, 1996.
<http://www.isgs.illinois.edu/nsdihome/webdocs/st-geolq.html>

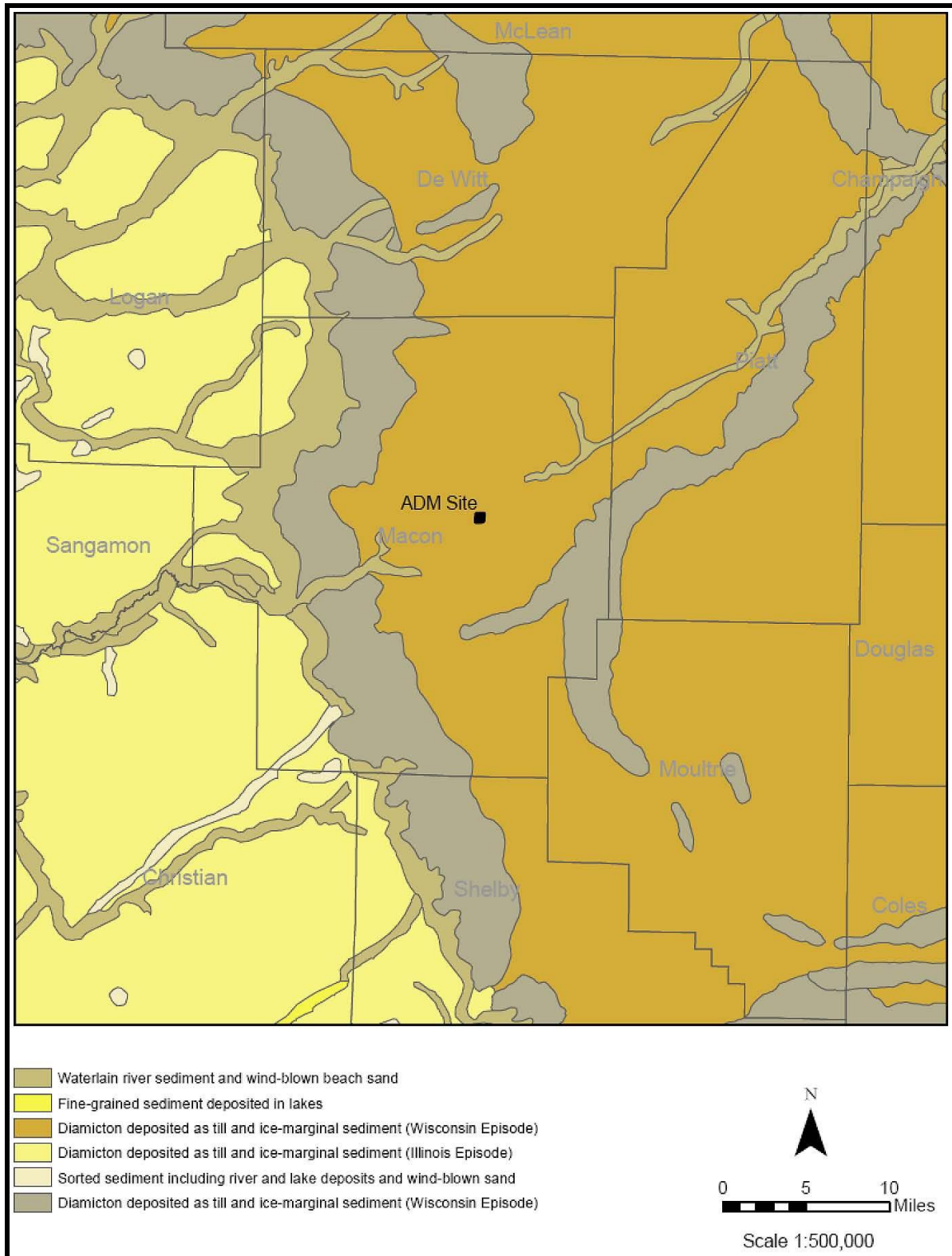

Figure 2-25: Vertical sequence of aquifers within the Quaternary sediments in Macon County (Larson et al., 2003)

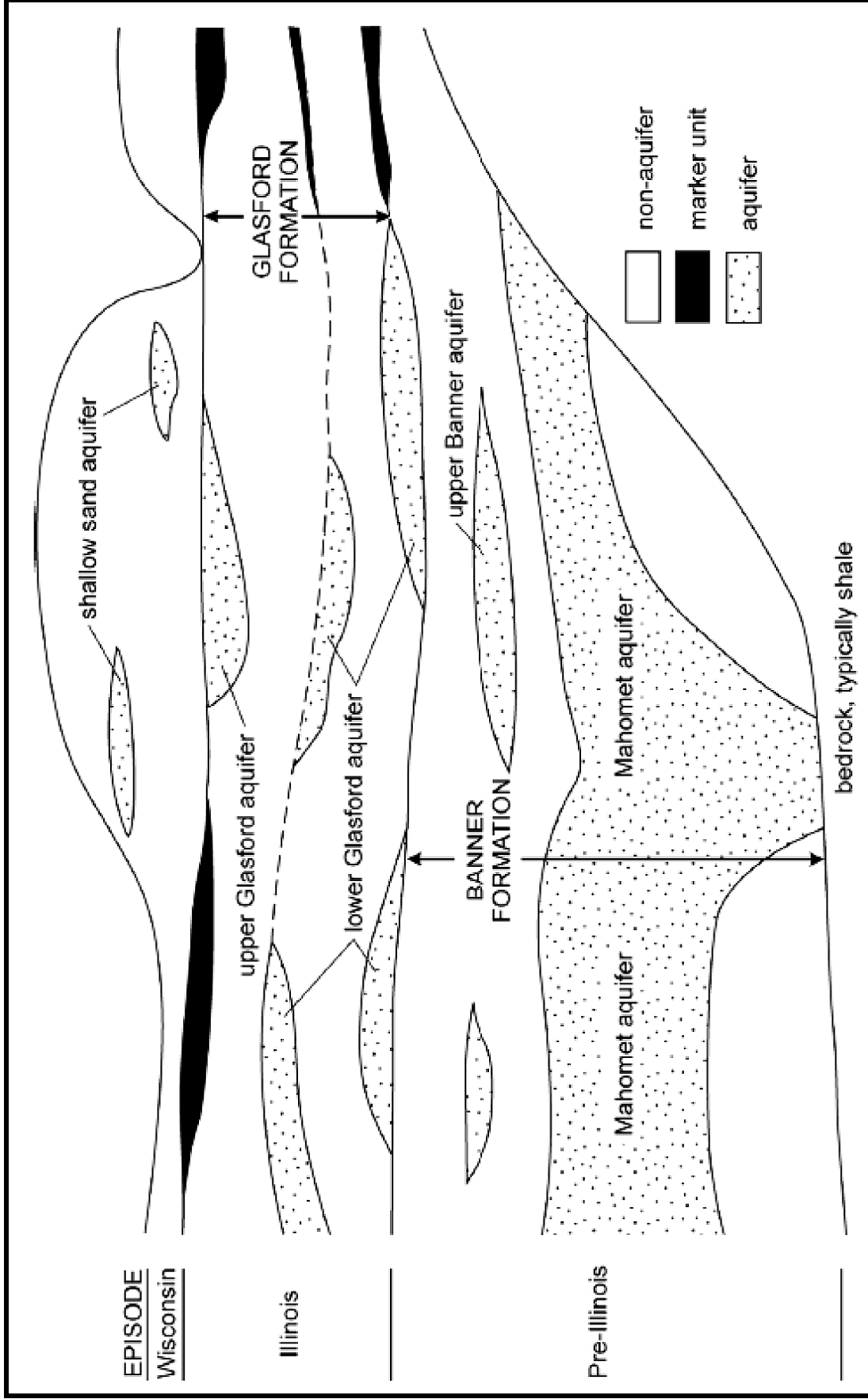

Figure 2-26: Depth to the top of the Mahomet aquifer (proposed injection well location in red) (Larson et al., 2003)

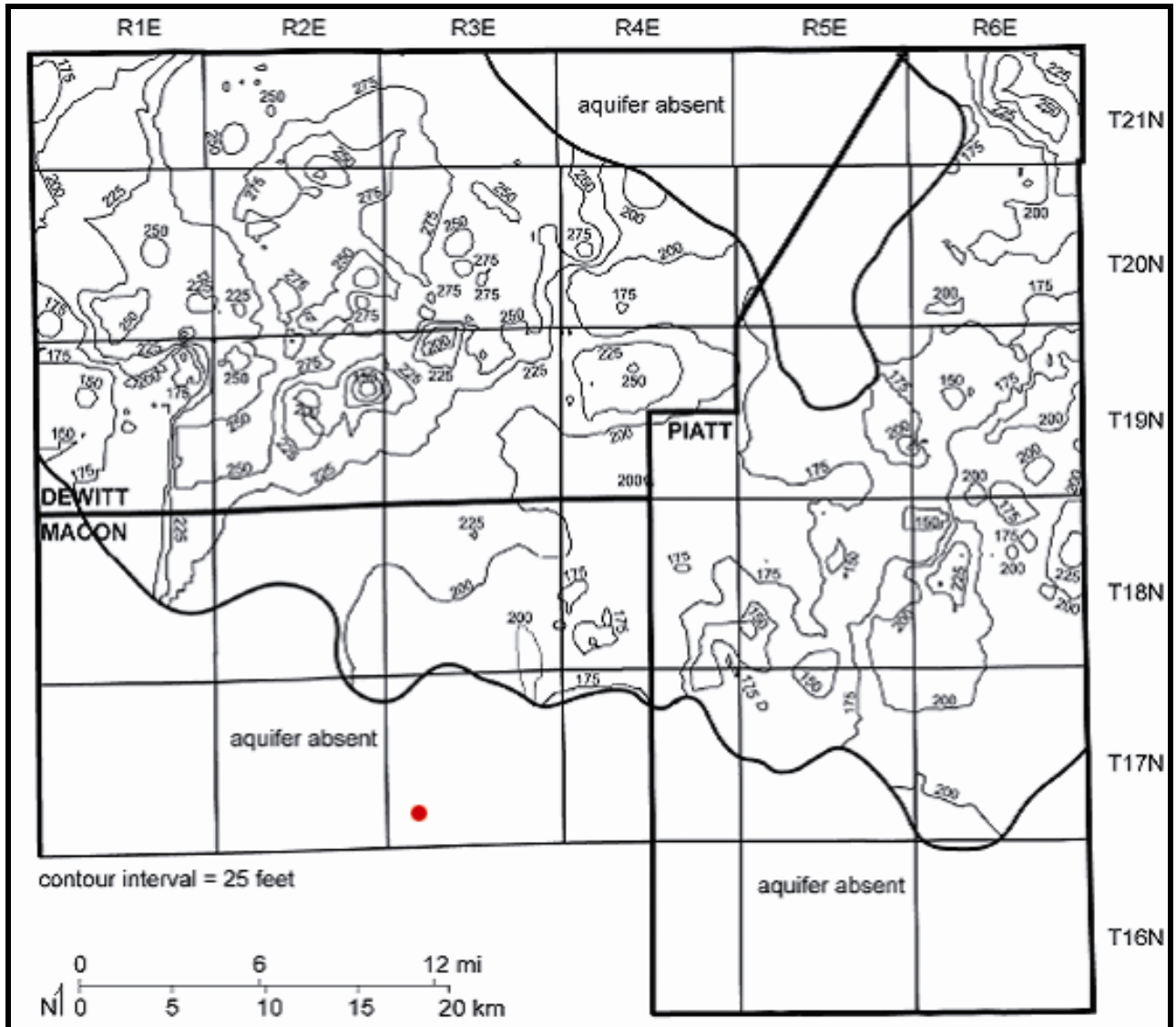

Figure 2-27: Thickness of the upper Banner aquifer (proposed injection well location in red) (Larson et al., 2003)

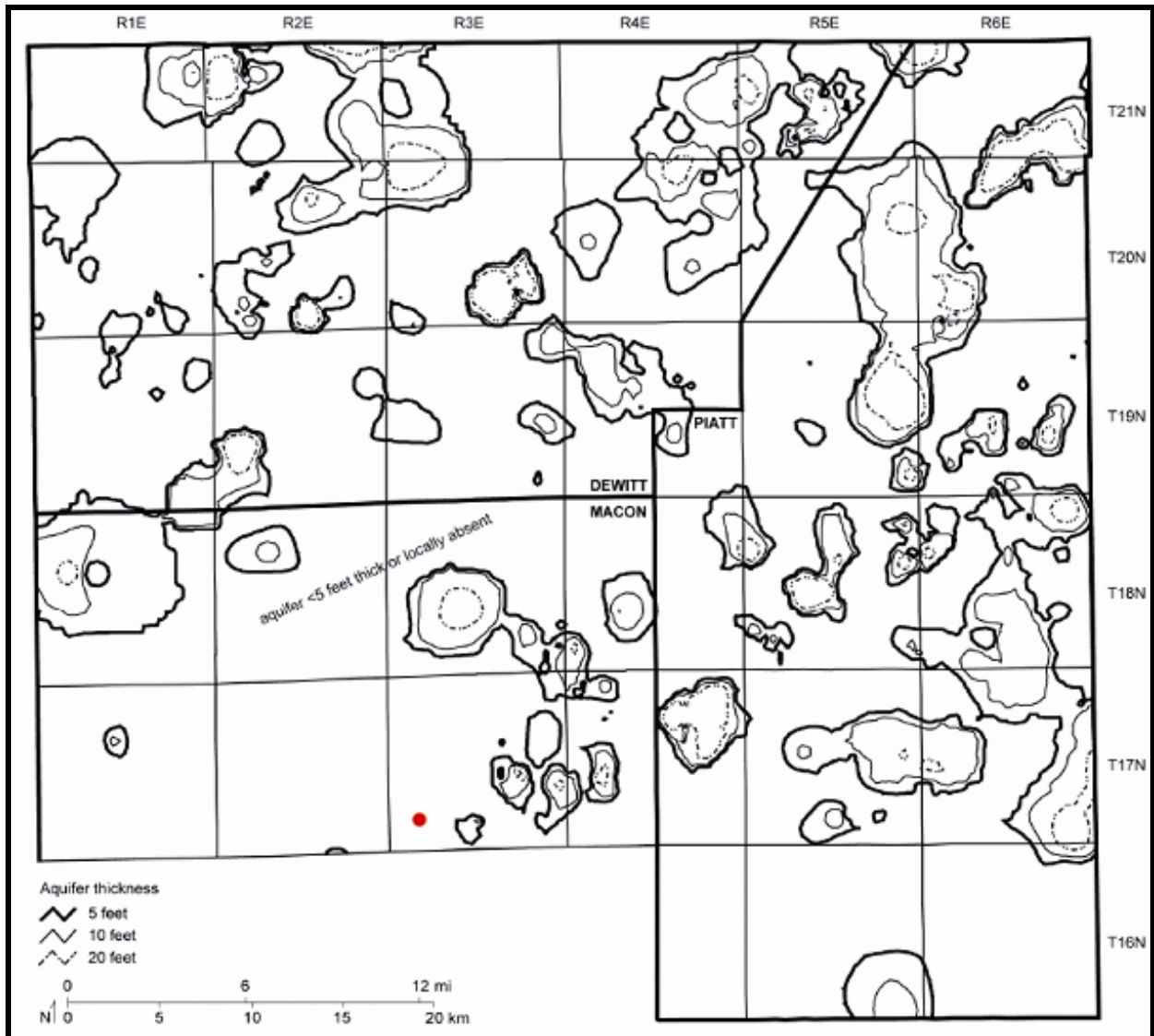

Figure 2-28: Thickness of the lower Glasford aquifer (proposed injection well location in red) (Larson et al., 2003)

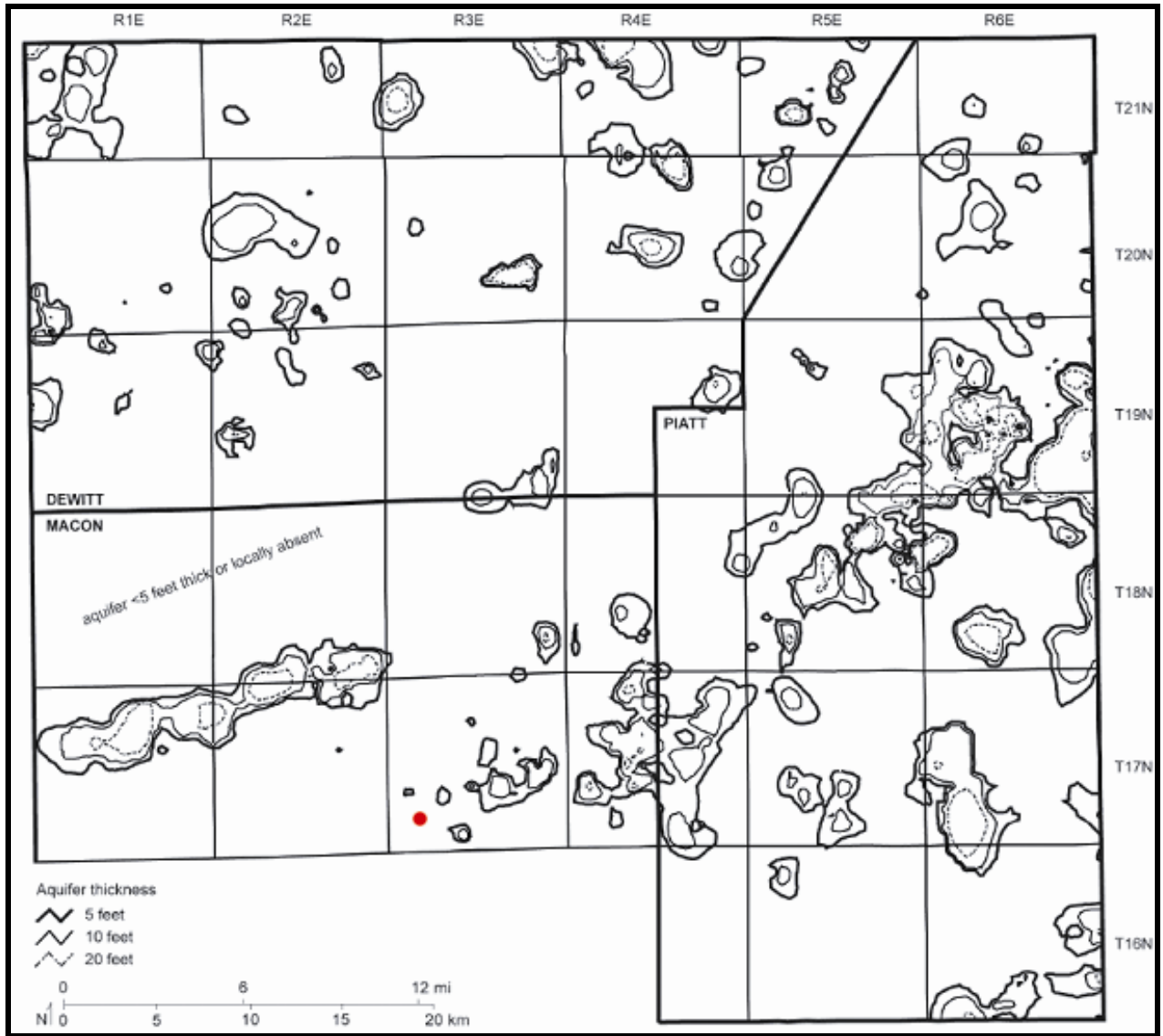

Figure 2-29: Thickness of the shallow sand aquifer (proposed injection well location in red) (Larson et al., 2003)

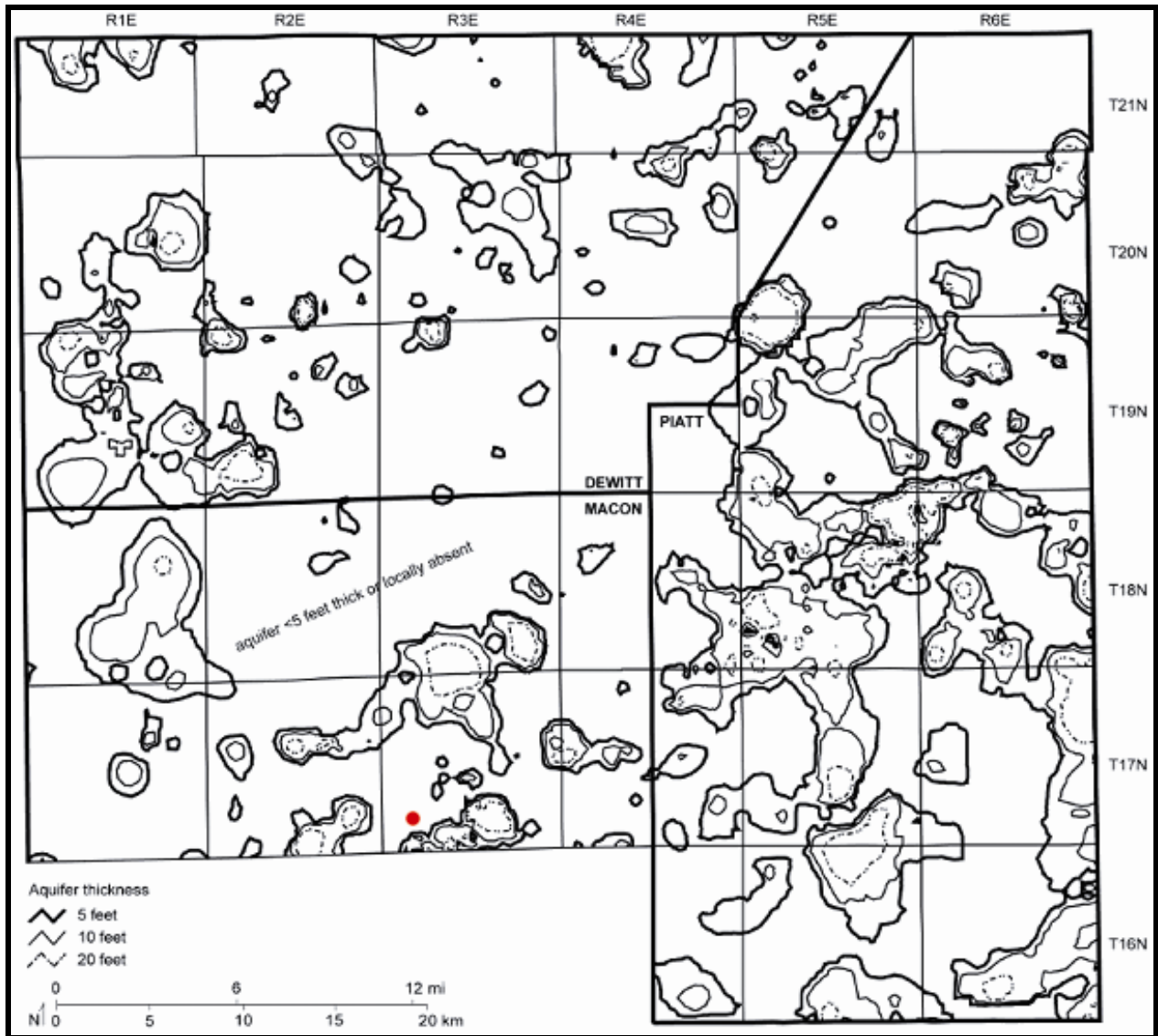

Figure 2-30: Thickness of the upper Glasford aquifer (proposed injection well location in red). (Larson et al., 2003)

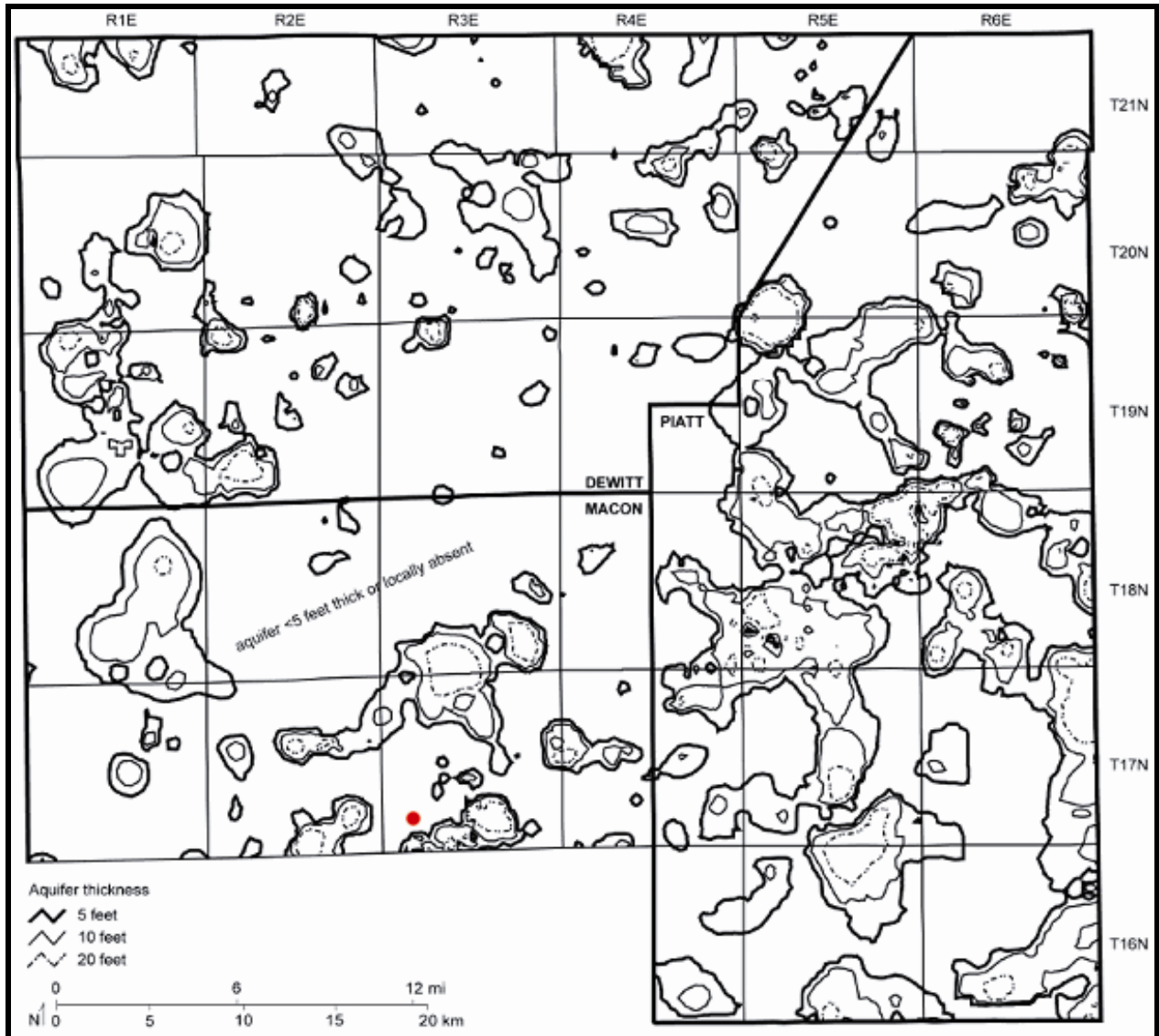

Figure 2-31: Regional bedrock geology near proposed IL-ICCS Injection Site, Decatur, IL.
 Source: ISGS Bedrock Geology GIS Dataset, 2005,
<http://www.isgs.illinois.edu/nsdihome/webdocs/st-geolb.html>

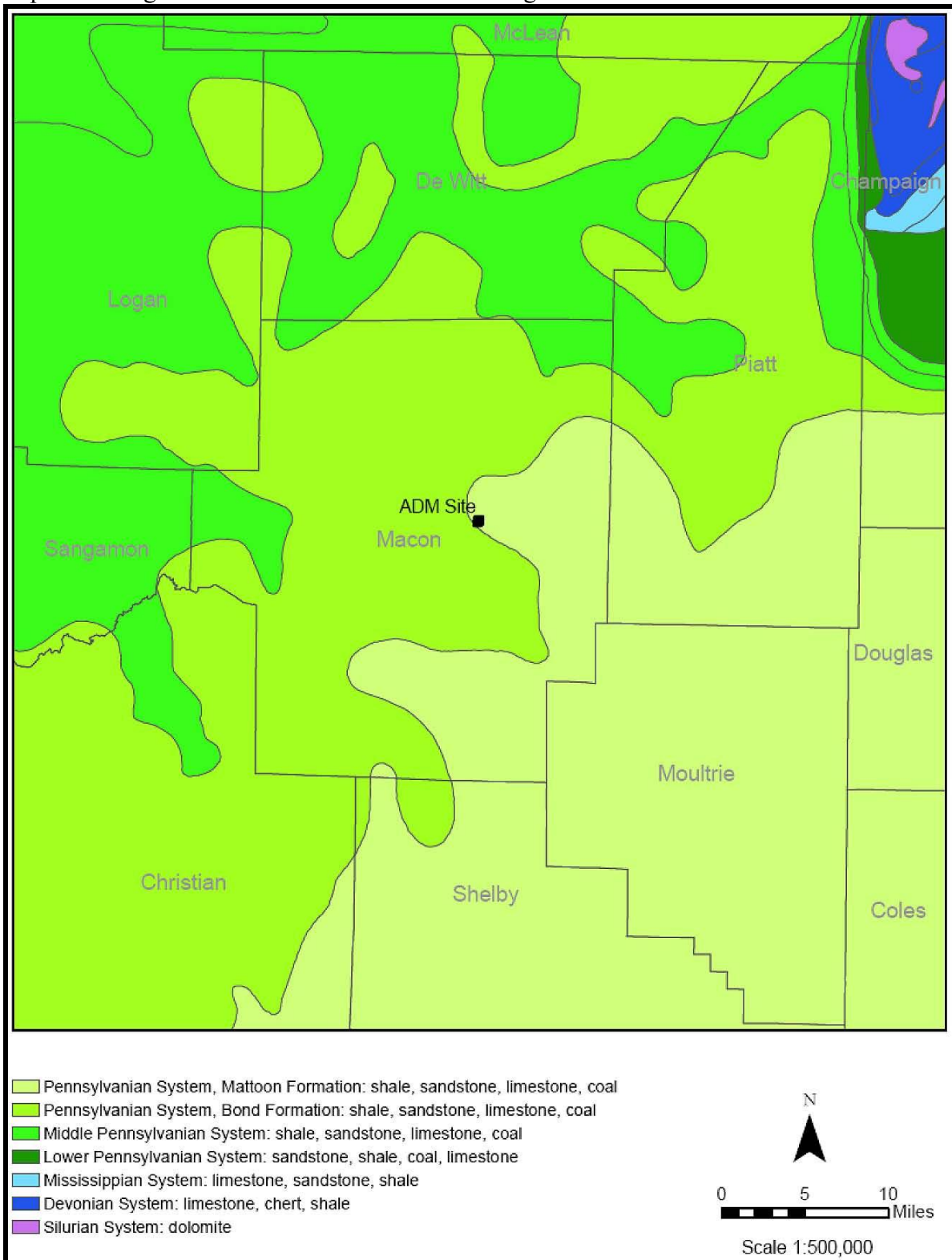

Figure 2-32: Map showing cross-section E-E' showing the depth to USDW (Vaiden, 1991).

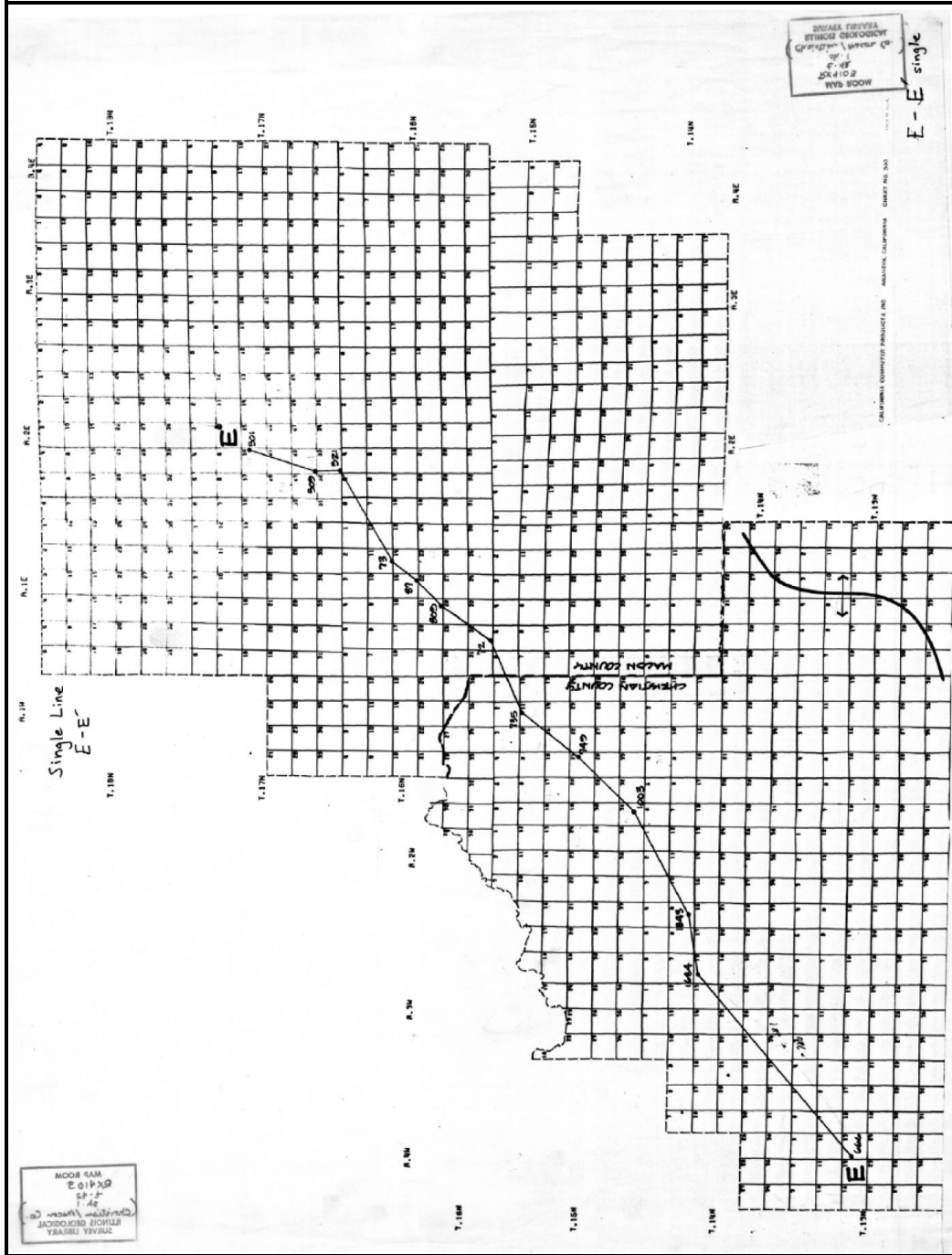
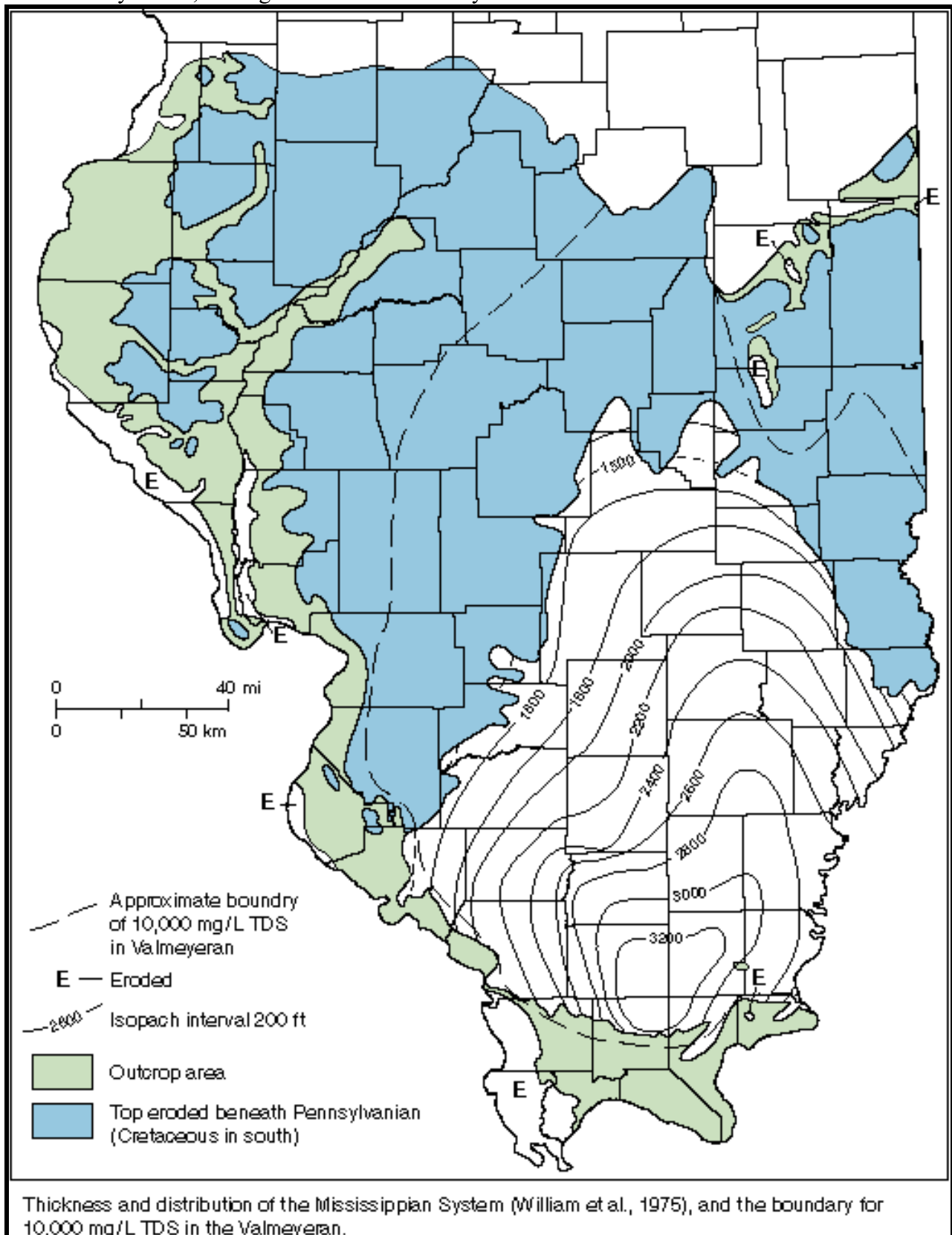

Figure 2-34: Thickness and distribution of the Mississippian System (Willman et al., 1975), and the boundary for 10,000 mg/L TDS in the Valmeyeran.



SECTION 3A - INJECTION WELL DESIGN AND CONSTRUCTION DATA

3A.1 Well Depth

The well design calls for drilling up to 150 feet into the granite basement in order to define the base of the Mt. Simon with open-hole and cased hole well logs. Based on the CCS #1 injection well completion report (Frommelt, 2010), the well depth is likely 7,250 ft and the casing and cementing program is designed for this depth. Actual well depth will be supplied in the completion report.

For permitting purposes, a well depth of up to 8,000 ft or up to 150 ft into the Precambrian granite basement is requested to account for any unforeseen variations Eau Claire or Mt. Simon thickness or elevation.

3A.2 Anticipated Fracturing Pressure

As reported in the CCS #1 completion report (Frommelt, 2010), the fracture gradient of the Mt. Simon was established to be 0.715 psi/ft depth. Fracture pressure of the Eau Claire formation above the Mt. Simon was estimated from four “mini-frac” tests (reference Section 2.5.3.2). The fracture pressure from these four tests ranged from 5,078 to 5,324 psig, corresponding to a fracture gradient ranging from 0.93 to 0.98 psi/ft in the Eau Claire shale.

Fracture pressures above the Mt. Simon and Eau Claire were not established and the following best estimates apply:

Dickey and Andresen (1946) and Buckwalter (1951) documented Illinois formations that had fracture gradients noticeably higher compared to deeper reservoirs elsewhere. An Illinois Basin fracture stimulation service company reported a fracture pressure gradient of slightly greater than 1.0 psi/ft for oil reservoirs in the Basin, and gave the calculated parting pressure from a recent Pennsylvanian sandstone frac job of 1.08 psi/ft (Robinson, 2003). Howard and Fast (1970) showed nonlinearity of the frac gradient between relatively shallower and deeper reservoirs. Based on 115 cement squeeze jobs, they found an average frac gradient of 0.8–0.95 psi/ft from a depth of 3,000 to 10,000 ft. Although there were limited data between 1,000 and 2,000 feet, they estimated a frac gradient of 0.95–1.95 psi/ft that increased with decreasing depth. This correlates with the higher measured ratios of horizontal to vertical stresses at shallower depths measured in the Illinois Basin. An additional indication of the successful storage of gas in the Mt. Simon without fracturing the overlying Eau Claire is the 10 underground natural gas storage reservoirs in Illinois operating in the Mt. Simon at depths ranging from 1,420 to 3,950 feet.

As noted, fracture pressures of the Mt. Simon and Eau Claire have already been determined at CCS #1. The fracture gradient of the injection zone for CCS #2 will be based on the former results at CCS #1 unless step rate tests in the Mt. Simon formation on CCS #2 are performed. A step rate test in the Eau Claire is not planned for CCS #2.

3A.3 Static Water Level and Type of Fluid

The CCS #1 well data suggests that the top of the Mt. Simon will occur at about 5,500 feet depth. The fluid in the Mt. Simon is hyper-saline brine with a median calculated TDS of ~197,000 mg/L (reference Section 2.4.4.5). Sodium and chloride are the predominant ions. A Mt. Simon pressure gradient of 0.455 psi/ft was measured in the CCS #1 injection well (reference Section 2.4.4.2), which resulted in the static fluid level occurring 220 ft below ground level. Using this pressure gradient, the pressure at the top of the Mt. Simon should be approximately 2,500 psi. The actual pressure and static level will be determined after the well is fully cased and perforated.

3A.4 Expected Service Life of Well

The expected service life of the well is projected to be at least 30 years. Because of the CO₂ resistant cement and metallurgy of the casing used in this well, the life of this well could be much longer if sequestration demands are present.

3A.5 Injection Well Completion

The well will be fully cased and then perforated for injection into the lower Mt Simon formation. All strings of casing will be cemented to surface. The lower portion of the long string will be cemented using a CO₂-resistant EverCRETE cementing system. CO₂ resistant cement will be placed from total depth through the Eau Claire formation and approximately 500 feet back into the intermediate casing. A conventional blend lead slurry will be pumped ahead of the CO₂ resistant cement to fill the annular space between the intermediate and long string casings. One intermediate casing string is planned; it will be set after drilling through the calcareous section of the upper Eau Claire formation and will be cemented to surface.

3A.6 Schematic or Other Appropriate Drawing of the Surface and Subsurface Construction Details of the Well

The schematic showing subsurface and surface construction details of the well are found in Figures 3A-1 & 3A-2.

3A.7 Well Design and Construction

The subsurface and surface design (casing, cement, and wellhead designs) exceeds minimum requirements to sustain the integrity of the caprock to ensure CO₂ remains in the Mt. Simon. For reasons such as equipment or supply availability, or changes to the supplemental monitoring program, the final well design may vary but will meet or exceed requirements in terms of strength and CO₂ compatibility.

The wellbore trajectory of each of the deep wells for the IL-ICCS project (injection, verification, and geophysical wells) will be tracked. The wells will be drilled to an inclination standard that will eliminate the risk of interception with adjacent wellbores and surveyed at least every 1,000 feet of depth to ensure compliance. Wells are planned to be held to less than 5 degree inclination.

Note that depths given are based on anticipated drilling conditions and estimated depths of formations and are subject to change. Final depths will be reported in the well completion report.

3A.7.1 Well Hole Diameters and Corresponding Depth Intervals

Table 3A-1 below summarizes the open-hole diameters. The surface casing will be set between 300 and 400 feet, nominally 350 feet, which is expected to be well below the lowermost USDW. The setting depth for the intermediate string is the top of the Eau Claire.

Table 3A-1: Open hole diameters and intervals

| Name | Depth Interval (feet) | Open Hole Diameter (inches) | Comment |
|--------------|-----------------------|-----------------------------|-----------------|
| Surface | 0-350 | 26 | To bedrock |
| Intermediate | 350-5,300 | 17 ½ | To primary seal |
| Long | 5,300-7,250 | 12 ¼ | To TD |

Note 1: Estimates given based on anticipated drilling conditions and depth of formations; permit request is up to 8,000 ft or up to 150 ft into the Precambrian granitic basement.

3A.7.2 Casing

The surface casing is planned to run between the surface and approximately 350 feet. The intermediate casing will run from the surface and be set in the Eau Claire (~5,300 feet). The long-string casing will be constructed from both carbon and chrome steels. The carbon steel will run from the surface to approximately 300 feet above the base of the intermediate casing and the chrome steel will start where the carbon steel ends and run to TD (~7,250 feet). Table 3A-2 provides further information on the casing strings that will be used in CCS #2.

Table 3A-2: Casing Specifications

| Name | Depth Interval (feet) | Outside Diameter (inches) | Inside Diameter (inches) | Weight (lbm/ft) | Grade (API) | Design Coupling (Short or Long Threaded) | Thermal Conductivity @ 77 ° F (BTU/ft.hr.°F) |
|----------------------------|-----------------------|---------------------------|--------------------------|-----------------|--------------|--|--|
| Surface ¹ | 0-350 | 20 | 19.124 | 94 | H40 | Short | 31 |
| Intermediate ² | 0-5,300 | 13 3/8 | 12.515 | 61 | K55 or J55 | Long or Butress | 31 |
| Long ³ (carbon) | 0- ~5,000 | 9 5/8 | 8.835 | 40.0 | N80 | Long or Butress | 31 |
| Long ³ (chrome) | ~5,000 --7,250 | 9 5/8 | 8.681 | 47.0 | Chrome alloy | Special | 16 |

Note 1: Surface casing will be 350 ft of 20 inch casing. After drilling a 26" hole to approximately 350' true vertical depth (TVD) or at least 50 ft into the bedrock below the shallow groundwater, 20", 94 ppf, H40, short thread and coupling (STC) casing will be set and cemented to surface. Coupling outside diameter is ~21 inches.

Note 2: Intermediate casing: 5,300 ft of 13 3/8 inch casing. After a shoe test or formation integrity test (FIT) is performed, a 17 1/2" hole will be drilled to approximately 5300' TVD or approximately 50' into the Eau Claire, the primary seal to the Mt. Simon. 13-3/8", 61 ppf, K55 or J55, long thread and coupling (LTC) or buttress thread and coupling (BTC) will be cemented to surface. Coupling outside diameter is ~14 3/8 inches.

Note 3: Long string casing: 0-5,000 ft of 9 5/8 inch, N80 casing; ~5000' - ~7250' of 9 5/8 inch, chrome alloy (e.g., 13Cr80). After a shoe test is performed and the integrity of the casing is tested, a 12 ¼" hole will be drilled to

approximately 7500' TVD or through the Mt. Simon, where the long string casing will be run and specially cemented. Coupling outside diameter is 10 3/8 inches for N-80 and 10.485 inches for the chrome alloy (e.g., 13Cr80).

Other Casing

No other casing strings are planned.

3A.7.3 Injection Tubing

The tubing design (Table 3A-3), calls for use of a 4.5-inch 12.6 lbm/ft chrome alloy string. The string will be ~7000 ft long and have a mass of 88,200 lbm. The maximum tensile stress specification for this string is 306,000 lbm.

Table 3A-3. Tubing Specifications

| Name | Depth Interval (feet) ¹ | Outside Diameter (inches) | Inside Diameter (inches) | Weight (lbm/ft) | Grade (API) | Design Coupling (Short or Long Thread) | Burst strength (psi) | Collapse strength (psi) |
|-----------------------------------|------------------------------------|---------------------------|--------------------------|-----------------|--------------|--|----------------------|-------------------------|
| Injection tubing ^{2,3,4} | 0~7,000 | 4 1/2 | 3.963 | 12.6 | Chrome alloy | Special | 8,960 | 7,820 |

Note 1: The tubing length will be finalized after the location of the perforations are selected and the packer location determined. The final tubing design may change subject to availability and/or pending results of reservoir analysis. The well casing design does allow for a larger tubing than 4 1/2" if required.

Note 2: Maximum allowable suspended weight based on joint strength of injection tubing. Specified yield strength (weakest point) on tubular and connection is 306,000 lbs.

Note 3: Weight of expected injection tubing string (axial load) in air (dead weight) will be 88,200 lbs.

Note 4: Thermal conductivity of tubing @ 77°F will be 16 BTU / ft.hr.°F.

3A.7.4 Cement

The casing strings will be cemented as outlined below:

Surface casing will be cemented back to surface, should fallback of more than 30 feet occur a surface grout job will be performed.

The planned cement interval for the intermediate string is to cement back to surface; the performance standard applied to the intermediate casing will be to have cement into the surface pipe. Should this standard not be achieved a cement bond log and or temperature survey will be run shortly after cementing to locate the actual cement top. After notifying the permitting agency and conferring as to the remediation required, a plan will be developed. The most likely scenario is that the annulus between the surface casing and intermediate casing will be grouted and pressure tested to insure hydraulic isolation. In any event, a Cement Bond Log with radial capability or Ultrasonic Cement Imaging logs will be run prior to running the long string casing.

On the long string, the planned cement interval is from TD back to surface; CO₂ resistant cement will be used from TD to at least 500 feet into the intermediate casing. The performance standard applied to the long string will be to have at least 1,000 feet of cement into the bottom section of

the intermediate casing. Should this standard not be achieved, a cement bond log and/or temperature survey will be used to establish the cement top. The permitting agency will be notified immediately and discussions will occur as to the best method to remediate. Options would include grouting, top filling from the surface where cement would be pumped into the annulus until annulus is “topped out”, or perforating above the cement top and attempting to circulate cement from the cement top. Perforations would then have to be squeezed off and pressure tested to 1,000 psi with no leak off. In any event, a Cement Bond Log with radial capability or Ultrasonic Cement Imaging logs will be run prior to the well completion.

The cementing programs provided in Table 3A-4 are estimates, and may be adjusted as a result of hole conditions, depths, etc.

Table 3A-4: Cement Specifications for CCS #2 Injection Well

| Casing | Depth Interval (feet) | Type/ Grade | Additives | Quantity (cubic feet) | Circulated to Surface | Thermal Conductivity (BTU/ft.hr. °F) |
|---------------------------|-----------------------|--|---|-----------------------------|-----------------------|--------------------------------------|
| Surface ¹ | 0-350 | Class A | Accelerator, LCM | 588 | Yes | 0.73 |
| Intermediate ² | 0-5,300 | Lead: 35:65 A/H- LP3:ClassA Tail: Class A or H | extender, antifoam, accelerator LCM dispersant | 3,882 (lead), 682 (tail) | Yes | 0.54 (lead) 0.74 (tail) |
| Long ³ | 0-7,250 | 35/65 Lead; CO ₂ resistant tail | Antifoam, dispersant, fluid loss + antissettling (tail) | 1,885 (lead), 978 (tail) | Yes | 0.75 |

Note 1: Surface casing: shall require +/- 490 sks of Class A + 2% CaCl₂ accelerator + 0.25 lb/sk D130 LCM, Density: 15.6 ppg, Yield: 1.19 cf/sk, Mix water: 5.23 gal/sk, Excess 75%

Note 2: : Intermediate casing: Lead slurry: +/- 1980 sks of lead 65-35 Cement-Poz, 4% Gell, 10% BWOW salt, + additives. Density: 12.9 ppg, Yield 1.96 cf/sk, Mix water: 9.95 gal/sk. Followed by tail slurry: +/- 620 sacks of Class A/H, Density: 15.6 -16.1 ppg, Yield: 1.10- 1.19 cf/sk, Mix water: 4.97- 5.234 gal/sk.

Note 3: Long string casing: Lead slurry: +/- 960 sks of 65-35 Cement-Poz + 6% extender + additives. Density: 12.5 ppg, Yield: 1.96 cf/sk, Mix water: 10.54 gal/sk; Excess 30% in O.H. and no excess inside intermediate additives. Followed by tail slurry: +/- 930 sks CO₂ Resistant blend + additives. Density: 15.9 ppg, Yield: 1.05 cf/sk, Mix water: 3.012 gal/sk.

CO₂-resistant cement will cover the entire open hole section from TD and be placed approximately 500 feet back into the intermediate casing. Assuming the intermediate casing will be set approximately 50 feet into the Eau Claire, the CO₂-resistant cement top will be about 450 feet above the Eau Claire.

Other Casing

There are no plans for additional casing strings at this time; however, depending on actual drilling conditions the well plan may be adjusted to accommodate unplanned events. The permitting agency will be notified prior to any casing additions.

Cementing Techniques, Equipment Positions, and Staging Depths

Casing centralizer design and placement will be performed for all casing strings to optimize casing centering and mud removal. Proper centralization is critical. Drilling and log data will provide well bore trajectory and hole size information and will be utilized in the design program.

The cement plan calls for single stage cementing for each casing string, assuming the hole conditions allow. A casing float shoe will be placed on the bottom of the casing string and a float collar placed one joint of casing above the bottom. A bottom wiper plug will be used to wipe the mud film from the casing ahead of the cement job. The bottom of the casing will be set a few feet off the bottom of the hole. Actual cement pumping and displacement rates will be determined using well specific parameters such as mud properties and hole size learned during the actual drilling process and will utilize wireline surveys, including a caliper log. A custom spacer will be pumped ahead of the cement system to assist in mud removal.

Although single stage cement jobs are planned for all casing strings, information from the drilling process (e.g. lost drilling returns) or open hole testing (e.g. significant fractures identified via well logs) could lead to a decision to use a two-stage cementing technique on any or all of the strings. The intermediate casing for CCS #1 was performed in a two-stage operation. If a lost circulation zone is encountered in this injection well then the expectation would be that a two stage job would be required. The CCS #1 well's long string was successfully cemented back to surface in a single stage operation, however should a two-stage cement system be required for the long string, the lower cement stage will cover the Mt. Simon and Eau Claire and come up to a few hundred feet above the Eau Claire. A stage cementing tool will be run on the long string allowing the second stage or upper section to be cemented after the lower cement stage has reached approximately 500 psi compressive strength. The designed lead system will cover the upper hole section and a small amount of the CO₂-resistant cement may be tailed in and placed across the stage cementing collar. The stage cementing collar will be drilled out and casing integrity test performed.

Section 7.5.4 of this application includes a description of the CO₂-resistant cement. Appendix B has the complete manufacturer's specifications. Table 3A-5 below is the manufacturers specifications for the specific density planned for lower portion of the injection casing cement.

Figure 3A-1: Subsurface schematic of the injection well.

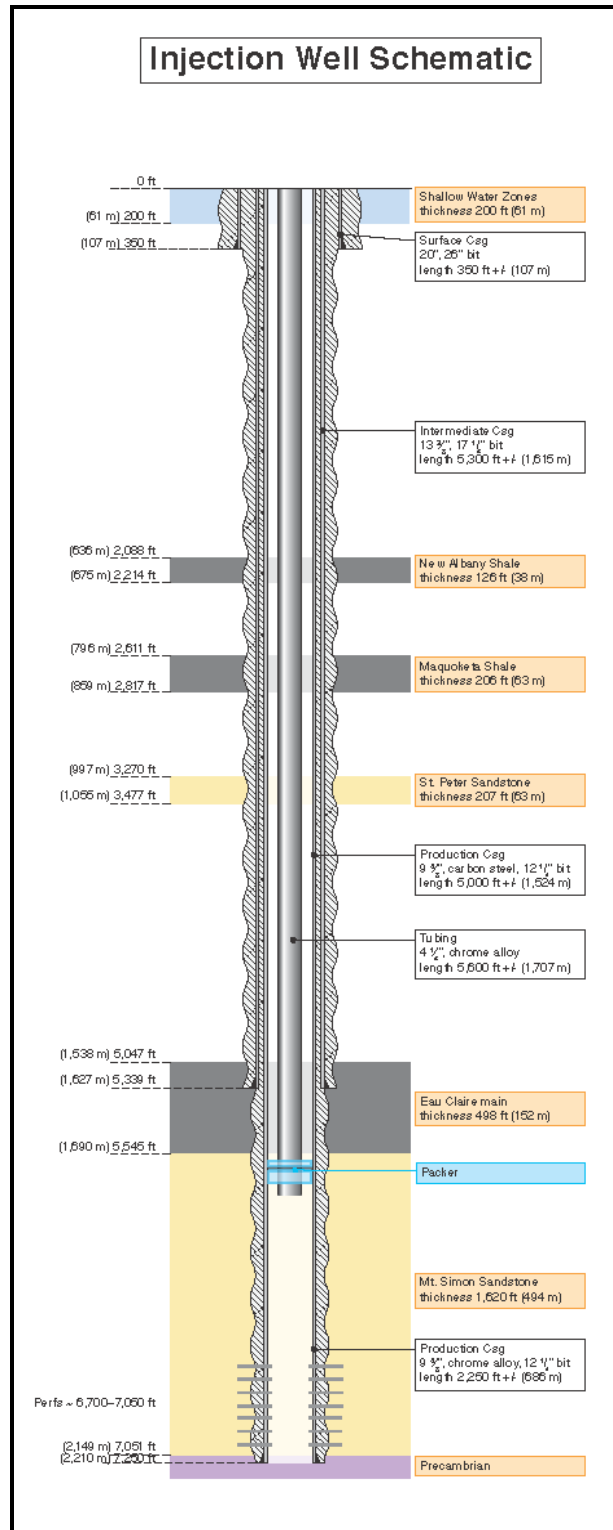

Figure 3A-2: Schematic of the wellhead of the injection well.

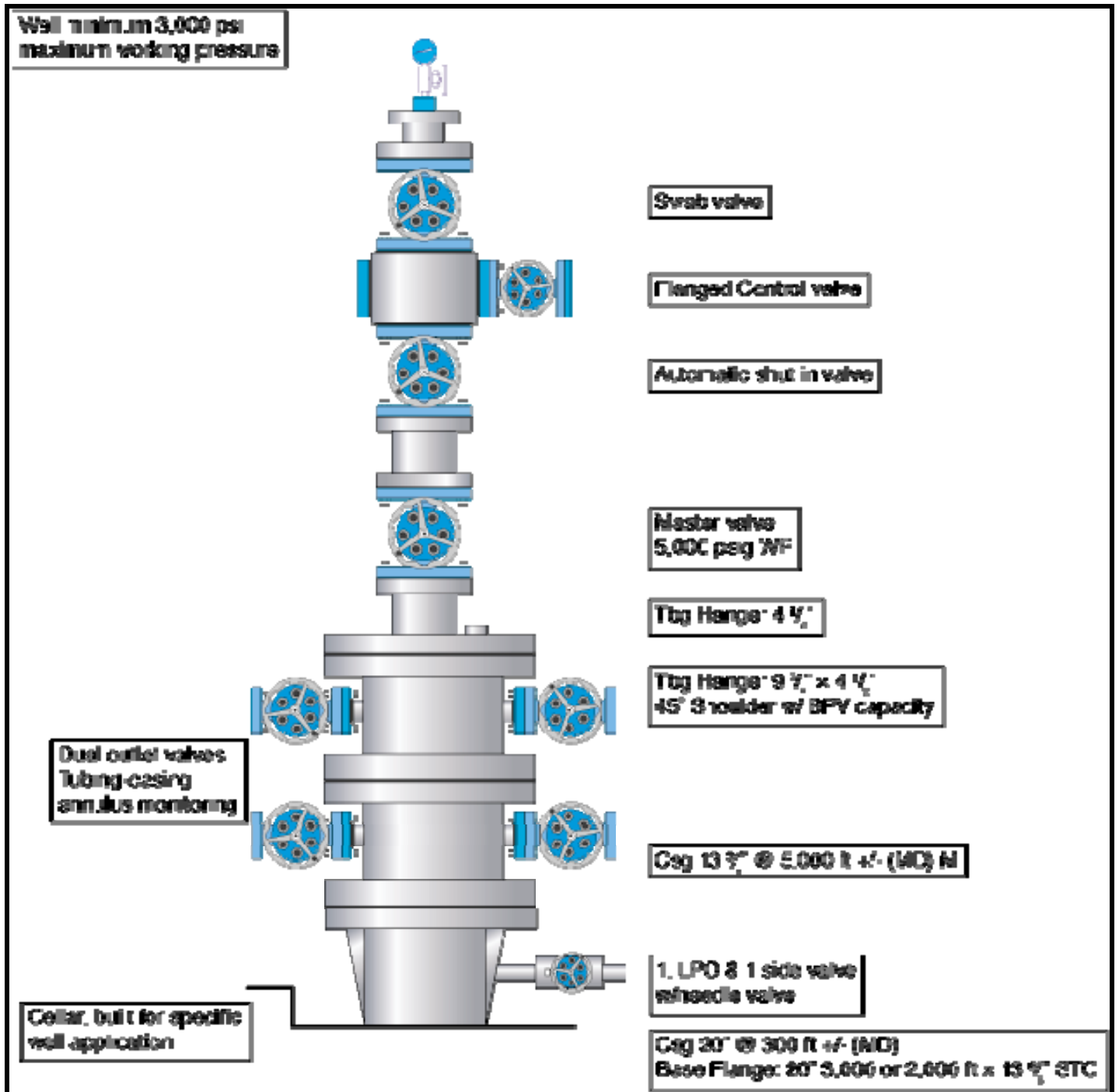

Table 3A-5: Manufacturers Cement Specifications

| | |
|--|---------------------|
| BHCT (Bottomhole circulating temperature) | 40 °C [104 °F] |
| BHST (Bottomhole static temperature) | 50 °C [122 °F] |
| Specific gravity [lbm/gal] | 15.9 ppg |
| Rheological properties determined with API R1B5 after mixing* | |
| PV (cp) (Plastic Viscosity) | 454.623 |
| T _y (lbf/100ft ²) (Yield Point) | 28.45 |
| After conditioning at BHCT | |
| PV (cp) | 247.198 |
| T _y (lbf/100ft ²) | 28.16 |
| 10 second gel strength (lbf/100ft ²) | 22 |
| 10 minute gel strength (lbf/100ft ²) | 25 |
| Then 1 minute stirring gel strength (lbf/100ft ²) | 19 |
| Stability | OK no sedimentation |
| API fluid loss at BHCT | 0 |
| Thickening time at BHCT | |
| 30 Bc | 1hr, 46 min |
| 70 Bc (unpumpable) | 4 hr, 18 min |
| UCA cell compressive strengths* | |
| 50 psi | 18 hr, 29 min |
| 500 psi | 21 hr, 07min |
| 24 hour comp. strength psi | 1177 |

Perforation Depths

A relatively high permeability zone in the lower Mt. Simon is the planned injection interval. The approximate gross interval is 6,700 feet to 7,050 feet. The perforation depths are to be finalized after drilling and will be reported in the well completion report.

3A.7.5 Annular Protection System

This section describes the annular protection system which monitors the annular space extending from the top of the packer to the surface.

The well will be constructed and operated to meet Federal requirements of 40 CFR Part 146 Subpart H, to establish and maintain mechanical integrity. The surface and intermediate strings will be cemented to surface.

The following procedures will be used to maintain and verify the integrity of the annulus:

- The annulus between the tubing and the long string of casing shall be filled with brine. The brine will have a specific gravity of 1.25 and a density of 10.5 ppg. The hydrostatic gradient is 0.546 psi/ft. The brine will contain a corrosion inhibitor.
- The surface annulus pressure will be kept at a minimum of 400 pounds per square inch (psi) at all times.
- The pressure within the annular space, over the interval above the packer to the confining layer, shall be greater than the pressure of the injection zone formation at all times.

- The pressure in the annular space directly above the packer shall be maintained at least 100 psi higher than the adjacent tubing pressure during injection. This does not include start-up and shut-down periods. See Figures 3A-3 through 3A-7 which show the basis of design for the annular system.

The annular monitoring system will consist of a continuous annular pressure gauge, a brine water storage reservoir, a low-volume/high-pressure pump, a control box, fluid volume measurement device, fluid, and electrical connections. The control box will receive pressure data from an annular pressure gauge and will be programmed to operate the pump as needed to maintain approximately 400 psi (or greater) on the annulus. A means to monitor the volume of fluid pumped into the annulus will be incorporated into the system by use of a tank fluid level gauge, flowmeter, pump stroke counter or other appropriate devices. Average annular pressure and fluid volumes changes will be recorded daily and reported to the permitting agency as required.

Figure 3A-4 provides an estimation of casing and tubing pressures during the period of maximum injection and if the annular protection system was designed such that the annulus pressure at any depth always exceeded the tubing pressure as per current guidance. This type of system would pose unnecessary risk to the integrity of the well. Applied surface pressures would create a higher likelihood of the creation of a micro annulus and would also impose a large differential across the packer. Casing pressures in the upper Mt. Simon could exceed the 90% of adjacent formation fracture pressures. For these reasons, the preferred approach is as described above and as shown in Figure 3A-7. The presence of the surface and intermediate casings in addition to the long string of casing provide 3 levels of protection to the USDWs.

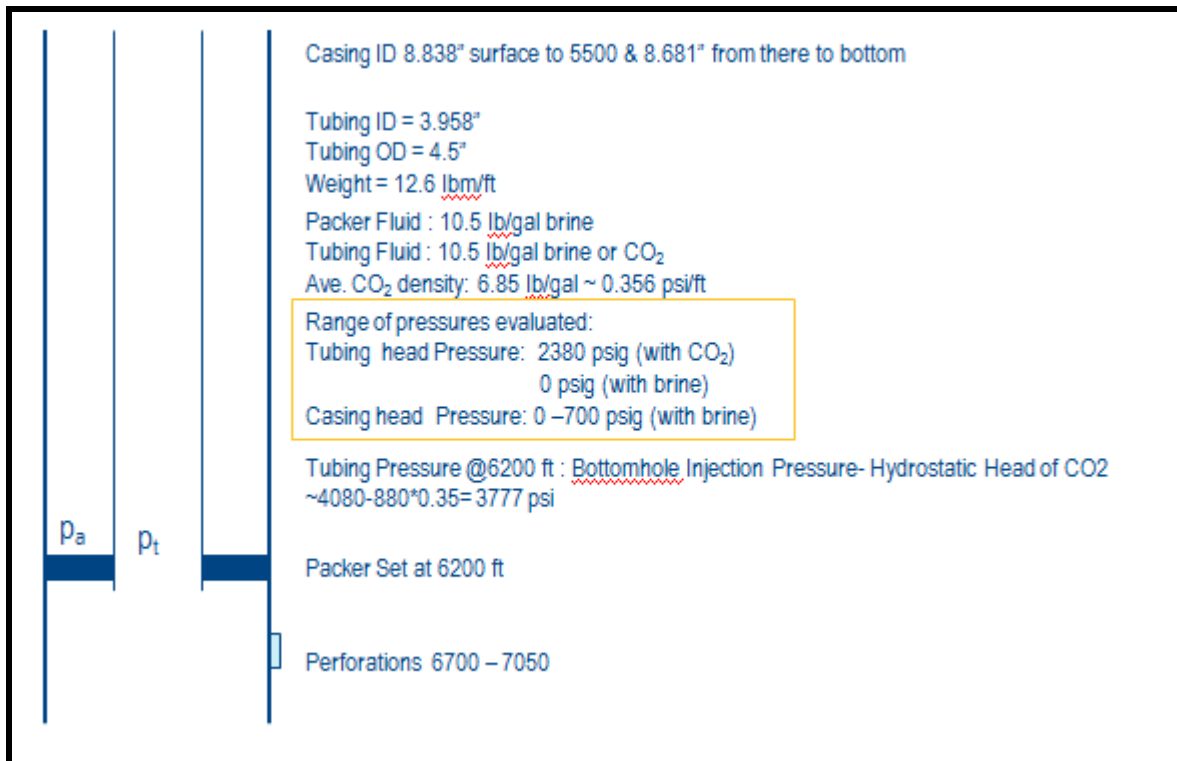

Figure 3A-3. Wellbore Parameters used in calculation of downhole annular and tubing pressures just above the packer.

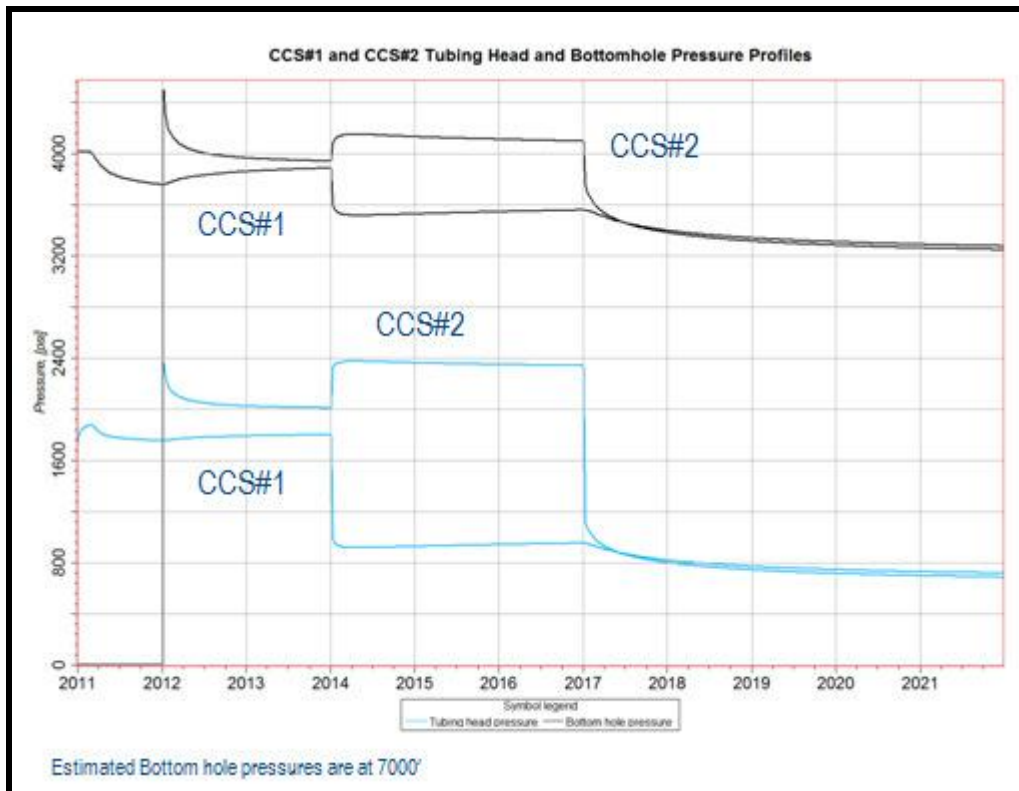

Figure 3A-4. Injection Pressure Profiles (modeled) for CCS #1 and CCS #2. This case used to demonstrate annular pressures will exceed tubing packer just above the packer if surface injection pressures are near the upper limit of 2380 psi. Lower injection pressures would create an even larger differential just above the packer. See Figure 3A-5.

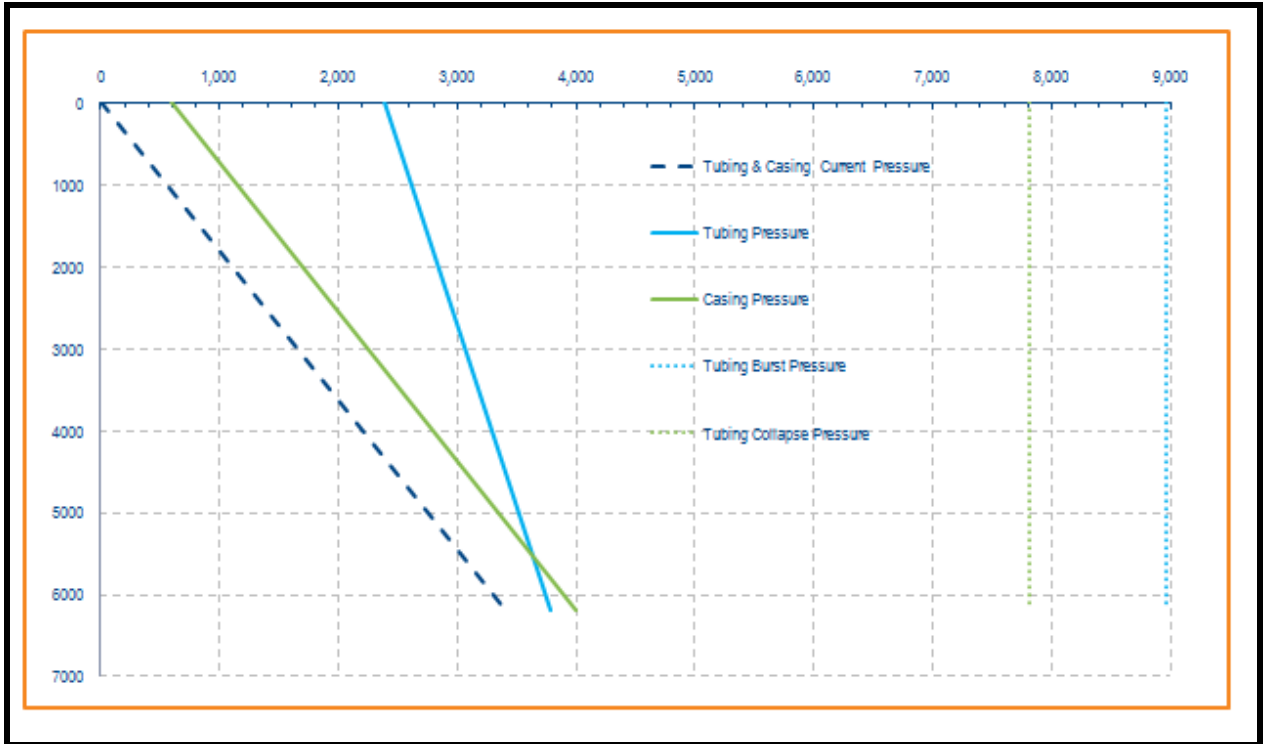

Figure 3A-5. Calculations using parameters from Figures 3A-3 & 3A-4 show that Annular pressure exceeds tubing pressure by 223 psi with packer set at 6200', 10.5# brine in annulus, and 600 psi annular pressure applied at surface.

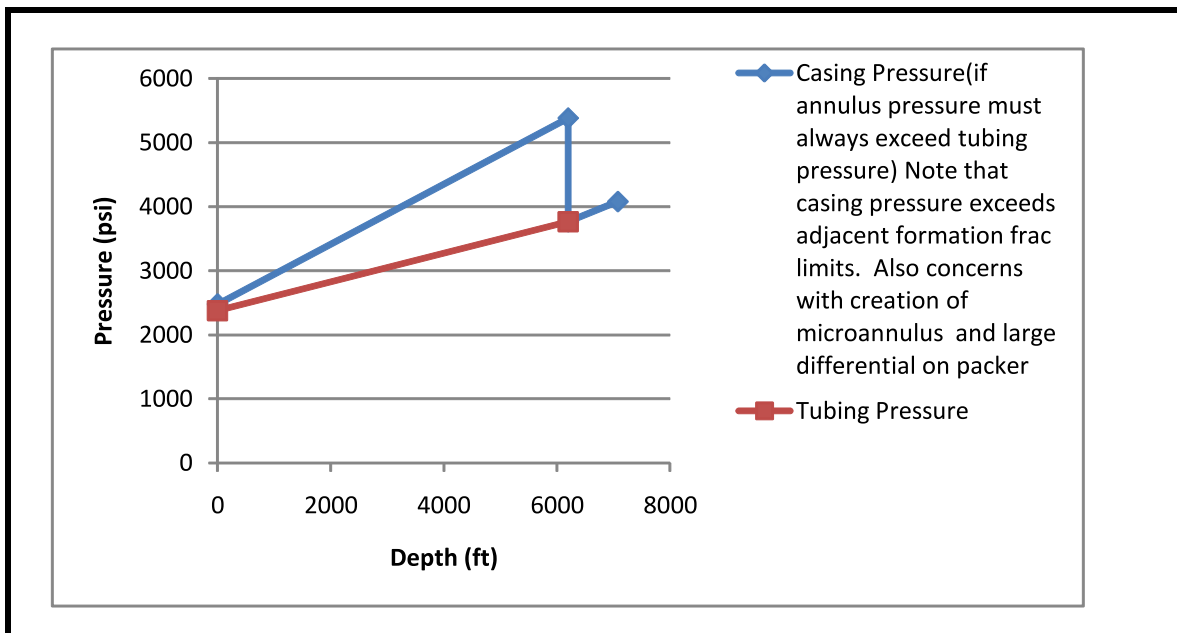

Figure 3A-6. Estimated Tubing and Casing pressures if annulus pressure at surface exceeds tubing pressure at surface as per 40 CFR 146.88 of Class VI regulations. Calculations use a 9.0 ppg annular fluid. See Figure 3A-7 for preferred alternative.

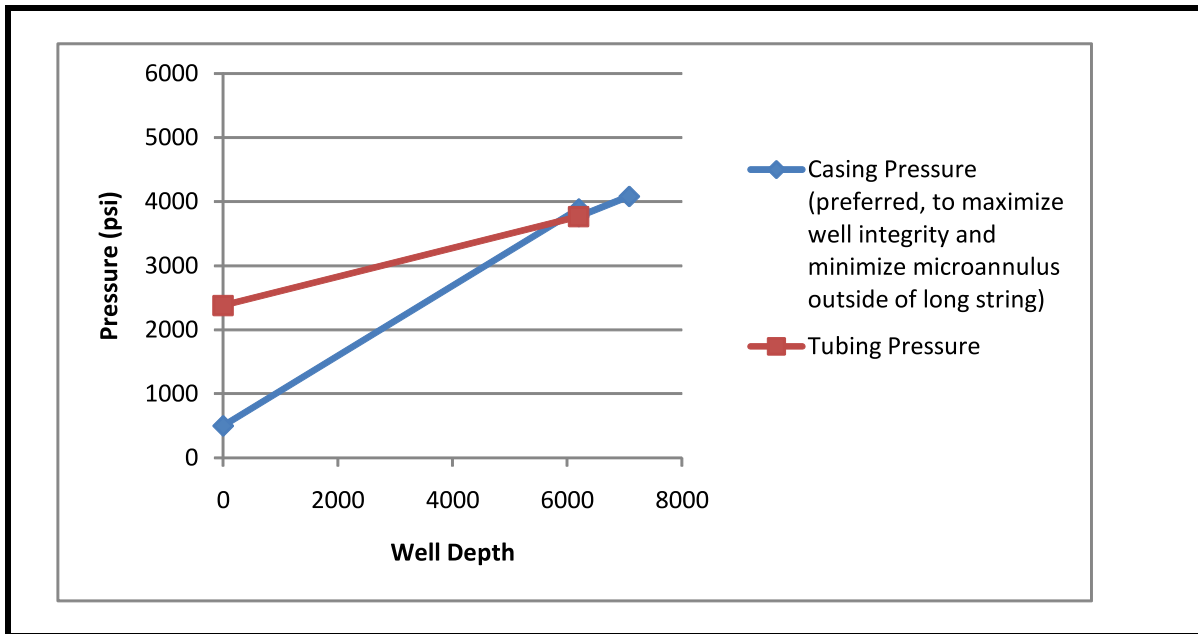

Figure 3A-7. Estimated Tubing and Casing Pressures as proposed with > 100 psi differential above the packer. Calculations based on 10.5 lb/gal annular fluid and 500 psi pressure applied at surface. Note that intermediate casing provides dual protection to formations above ~ 5350'.

Packer or Fluid Seal

The packer design calls for a Schlumberger Quantum Max Type III Seal-bore Assembly packer composed of chrome steel. The sealing elements of the packer and seal-bore assembly are comprised of nitrile rubber which is designed to be durable in environments with high CO₂ concentration. As a result, reactivity between the injected CO₂ and the injection packer is expected to be negligible.

The packer and the amount of weight that will be set on top of it will be designed to account for the buckling and other forces that will be exerted during the injectivity phases, thus ensuring integrity of the annulus.

The packer will have a CO₂ compatible elastomer. The dry CO₂ should not react with the steel components of the packer. The tubing and packer will be compatible with CO₂: the elastomer packer element will be selected to resist CO₂ and the packer body will be made of chrome steel. No “blanket” of diesel or kerosene or similar non-reactive fluid will be placed below the packer. CO₂ is less dense than water and is less dense or very similar in density to many hydrocarbon liquids like diesel and kerosene. It is highly unlikely that these types of fluids would remain in place under the packer from buoyancy effects with CO₂.

Packer is expected to be set in the upper to middle Mt. Simon section. Some distance between the initial perforations and the tubing tail will be maintained so that additional perforations can be added at a later date, if required. The final packer setting depth will be based on petrophysical data after the injection well is drilled.

Prior to inserting the upper polished rod assembly into the seal-bore assembly, a temporary plug will exist in the tailpipe and the annular fluid will be circulated 2-3 times through the casing-tubing annular volume and conditioned to the specifications as listed above, before setting packer. The packer will then be tested by applying 1000 psi surface pressure on the annulus. This is in addition to the hydrostatic pressure imposed by the annular fluid. The surface pressure will be held for 15 minutes while monitoring with a surface recorder.

3A.8 Information on Well Drilling Company Used During Construction

Drilling Firm Information

A drilling contractor has not yet been selected. This decision will be based on rig availability and the final decision of project management regarding procurement. The order in which the wells are drilled and completed may vary. Details about the drilling contractor will be provided in the well completion report.

Drilling Schedule

The preliminary drilling & completion schedule and additional details are included as Figure 3A-8. Utilization of a single drilling rig to sequentially drill the injection, verification, and geophysical monitor wells is planned and will provide the best consistency and quality of the many services required for drilling wells.

Drilling Method

A rotary drilling rig will be used to drill CCS #2. The expected rig will be of a minimum rating to drill to expected depth and handle designed casing loads as well as have the set-back capacity adequate to drill a well to this depth. Blow Out Preventers (BOP) will be used in the unexpected event of an interval or zone having higher pressure than anticipated. The mud system will be designed to maintain overbalanced drilling.

3A.9 Tests and Logs

ADM will provide a schedule for all testing and logging to the permitting agency at least 30 days in advance of conducting the first such tests and/or logs.

3A.9.1 During Drilling

Each open hole section (prior to setting each casing string) will be logged with multiple suites to fully characterize the geologic formations (reservoirs and seals). At a minimum, all wireline runs will have resistivity, spontaneous potential (SP), gamma ray (GR) and caliper logs. Sonic and porosity logs additionally will be included on the intermediate and TD run. The TD run will also include magnetic resonance, micro-imaging (dipmeter and fracture ID), formation pressure and rotary cores.

For the injection well, at least 90 feet of whole core are planned for the Eau Claire and the Mt. Simon. Additional core may be taken elsewhere in the well. Based on the open hole well logs, additional cores may be obtained using a sidewall rotary coring tool.

A Cement Bond Log (CBL) with radial capability and/or Ultrasonic Cement Imaging logs will be run on all casings strings with a possible exception for the surface casing. Due to the large surface casing size, a cement bond log with radial imaging may not be possible; however, a conventional CBL and temperature log can be run. Cement evaluation logs in very large casings typically can be ambiguous and are qualitative at best. The best indicator for good cement quality on the surface casing might best be judged by whether the cement is returned to surface with no fallback and if the surface casing shoe test is successful.

3A.9.2 *During and After Casing Installation*

A baseline reservoir saturation tool (RST) and Temperature log will be run to be compared later with multiple passes during and after injection for detailed knowledge of where the CO₂ has moved vertically. Careful monitoring of the top of the Mt. Simon Sandstone formation, as well as the porous zones above the seal, will be used to confirm the integrity of the completion.

A Cement Bond Log with radial capability or Ultrasonic Cement Imaging logs with radial capability will be run on the intermediate and long string casings. Ultrasonic Imaging logs will provide casing thickness and internal radius baseline measurements in addition to cement evaluation data. Casing internal diameters will be initially baselined by running a multi-finger caliper (MFC) log in the long string casing prior to the well completion. Follow-up MFC logs in the long string casing can be run if the tubing is ever temporarily removed.

Based on previous analysis and results in the area, stimulation via hydraulic fracturing of the injection zone will not be required. The use of an acid to reduce perforation skin will be avoided if possible. An underbalanced perforating technique, either static or dynamic in nature will likely be utilized.

After the well is cased, at least one and possibly several, injectivity or pump tests may be performed to provide data for the reservoir modeling. Since injectivity testing is best analyzed in a single-phase fluid environment, the gauges would be placed near a perforated interval, and then several injections with pressure fall-off measurements can be performed. Several cycles of this should give excellent measurements to model the ability of the reservoir to receive injectate. Also at this time, the step rate test referenced in 3A.2 can be performed. The final perforating scheme will be based on data interpretation and test results.

3A.9.3 *Demonstration of Mechanical Integrity*

Cement and system mechanical integrity will be verified with cement imaging logs with a radial capability (e.g. Schlumberger Slim Cement Mapping Tool (SCMT), UltraSonic Imaging Tool (USIT), etc). Furthermore, mechanical integrity will be confirmed by pressure testing the casing (750 psig) prior to perforating, and after the packer is installed, the tubing/casing annulus will be pressure tested. All tests will be recorded. A successful test will be confirmed when casing pressure holds for one hour with less than 3% loss in pressure. As mentioned above, a baseline

reservoir saturation tool (RST) log will be run. Repeat RST logs can be run if anomalous temperature data indicates a need for further analysis. Careful monitoring with temperature data across the top of the Mt. Simon Sandstone formation, as well as the porous zones above the seal, will be used (along with data from the verification well) to confirm the integrity of the completion.

3A.9.4 Copies of the Logs and Tests Listed Above

The logs and tests listed above will be conducted during well construction and copies of these logs will be included in the well completion report provided to the permitting agency.

3A.10 References

Dickey, P.A. and Andresen K.H. 1946. "Selection of Pressure Water Flooding Various Reservoirs," Drilling and Production Practice, American Petroleum Institute.

Buckwalter, J.F. 1951. "Selection of Pressure Water Flooding Various Reservoirs", Drilling and Production Practice, American Petroleum Institute.

Robinson, J. 2003. Personal communication, Franklin Well Services, Lawrenceville, Illinois.

Howard, G. C. and C.R. Fast. 1970. Hydraulic Fracturing, New York Society of Petroleum Engineers of AIME, 210 p.

Frommelt, D., 2010. Letter to the Illinois Environmental Protection Agency, Subject: CCS Well #1 Completion Report, Archer Daniels Midland Company – UIC Permit UIC-012-ADM, dated May 5, 2010.

Figure 3A-8: Preliminary Well Drilling and Completion Schedule

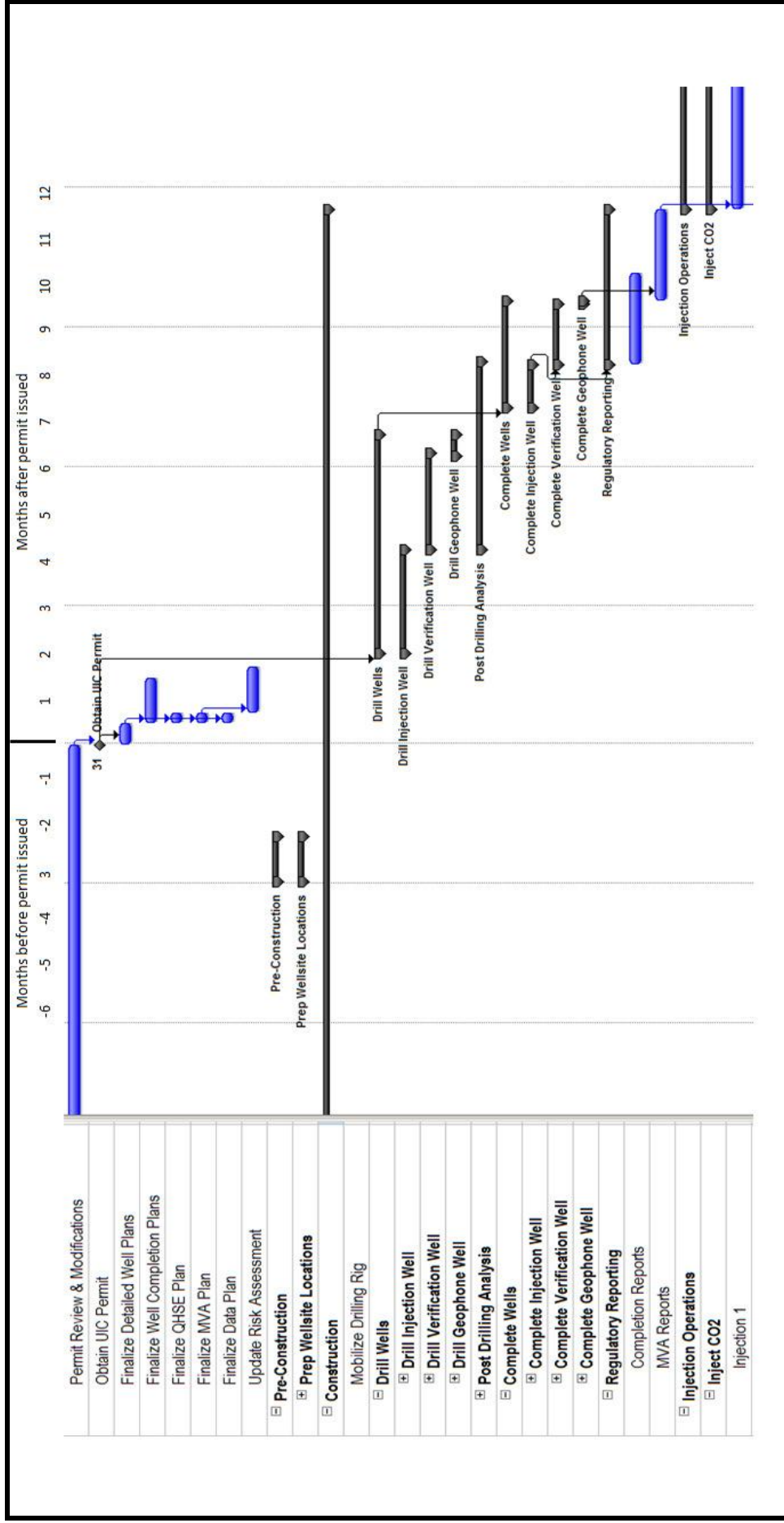

SECTION 3B – VERIFICATION WELL DESIGN AND CONSTRUCTION DATA

3B.1 Well Depth

The well design will be to drill up to 150 feet into the granite basement in order to define the base of the Mt. Simon with open-hole and cased hole well logs. Based on the CCS #1 injection well completion report (Frommelt, 2010), the well depth is likely 7,250 ft and the casing and cementing program is designed for this depth. Actual well depth will be supplied in the completion report.

For permitting purposes, a well depth of up to 8,000 ft or up to 150 ft into the Precambrian granite basement is requested to account for any unforeseen variations Eau Claire or Mt. Simon thickness or elevation.

3B.2 Anticipated Fracturing Pressure

As reported in the CCS #1 completion report (Frommelt, 2010), the fracture pressure of the Mt. Simon was established to be 0.715 psi/ft. Fracture pressure of the Eau Claire formation above the Mt. Simon was estimated from four “mini-frac” tests (reference Section 2.5.3.2). The fracture pressure from these four tests ranged from 5,078 to 5,324 psig, corresponding to a fracture gradient ranging from 0.93 to 0.98 psi/ft in the Eau Claire shale.

3B.3 Static Water Level and Type of Fluid

The CCS #1 well data suggests that the top of the Mt. Simon will occur at about 5,500 ft depth. The fluid in the Mt. Simon is hyper-saline brine with a median calculated TDS of ~197,000 mg/L (reference Section 2.4.4.5). Sodium and chloride are the predominant ions. A Mt. Simon pressure gradient of 0.455 psi/ft was measured in the CCS#1 injection well (reference Section 2.4.4.2), which resulted in the static fluid level occurring 220 ft below ground level. Using this pressure gradient, the pressure at the top of the Mt. Simon should be approximately 2,500 psi. The actual pressure and static level will be determined after the well is fully cased and perforated.

3B.4 Expected Service Life of Well

The expected service life of the well is projected to be at least 30 years. Because of the CO₂ resistant cement and metallurgy of the casing used in this well, the life of this well could be much longer if sequestration demands are present.

3B.5 Verification Well Completion

The verification well will be cased to total depth (TD) and each string will be cemented to prevent movement of fluid along the borehole and outside of the casings. The lower portion of the long string will be cemented with a CO₂-resistant EverCRETE cementing system. The CO₂ resistant cement will cover the entire open hole section from TD and be placed from total depth through the Eau Claire formation and approximately 500 feet back into the intermediate casing. A conventional blend lead slurry will pumped ahead of the CO₂ resistant cement to fill the

annular space between the intermediate and long string casings. One intermediate casing string is planned; it will be set after drilling into the calcareous section of the upper Eau Claire Formation and will be cemented to surface. The well will be perforated at discrete intervals in the Mt. Simon (Table 3B-1). No monitoring intervals or perforations will be placed above the primary seal (Eau Claire) or the secondary seal (Maquoketa).

In the verification well, a Westbay monitoring system will be installed in the wellbore with packers straddling each set of perforations along with redundant packers and quality assurance monitoring zones to prevent fluid movement in the tubing/casing annulus between zones. The Westbay monitoring system is outlined in detail in Section 6B.

Results of the first round of Westbay sampling, analysis results, and pressures will be submitted in the well completion report. The information will also include a report of measured hydrostatic gradients between the formations of interest. The Westbay test results are expected to be the last step for verification well completion.

Perforation Depths. The verification well perforations are expected to be placed at seven intervals in the Mt. Simon formation in an attempt to more clearly understand how the injected CO₂ moves through the reservoir. Fluid sampling and pressure monitoring in these zones will be used to measure pressure effects of injected CO₂.

Table 3B-1 below lists an estimate of perforation depths for Westbay monitoring. Depths are based on the well logs from the IBDP injection well (CCS #1); final perforations will likely change and will be reported in the well completion report.

Table 3B-1. Westbay perforation location table. SPF = slots per foot.

| Interval | Depth | Formation | Interval / SPF |
|----------|-------|-----------|---------------------------|
| 1 | 5,700 | Mt. Simon | Approx 3 ft / Up to 4 SPF |
| 2 | 6,060 | Mt. Simon | Approx 3 ft / Up to 4 SPF |
| 3 | 6,540 | Mt. Simon | Approx 3 ft / Up to 4 SPF |
| 4 | 6,655 | Mt. Simon | Approx 3 ft / Up to 4 SPF |
| 5 | 6,805 | Mt. Simon | Approx 3 ft / Up to 4 SPF |
| 6 | 6,910 | Mt. Simon | Approx 3 ft / Up to 4 SPF |
| 7 | 7,025 | Mt. Simon | Approx 3 ft / Up to 4 SPF |

Completion Fluid: During the initial completion, when the Westbay System is being installed, a completion or kill brine of 9.4 ppg will be used. This brine will be NaCl based with a specific gravity of 1.11 to 1.13 with a hydrostatic gradient of approximately 0.488 psi/ft.

After injection begins, there will be a gradual pressure increase in the Mt. Simon formation. The current reservoir modeling (reference Section 5) suggests that the ultimate pressure increase at Verification Well #2 will be less than 500 psi. During this period of peak pressure, the corresponding gradient is approximately 0.53 psi/ft. In other words, a brine weight of approximately 10.2 ppg would be required to kill the well, in the event of a 500 psi increase to the original, pre-injection reservoir pressure. This increase in pressure, however, dissipates relatively quickly after injection is ceased. The use of a heavy brine for an annular fluid would be detrimental to the direct measurements (sampling), so the completion fluid will be kept near

the specified 9.4 ppg during the original installation. A heavier brine can be placed above the uppermost Westbay packer later in the life of the well as required. This is done by opening the uppermost sliding sleeve assembly and then circulating through the sliding sleeve, followed by closing of the sliding sleeve.

3B.6 Schematic or Other Appropriate Drawing of the Surface and Subsurface Construction Details of the Well

Schematics showing subsurface and surface construction details of the verification well are found in Figures 3B-2, 3B-3, and 3B-4. Figure 3B-5 shows the Verification Well Instrumentation Schematic and Summary.

Note: Casing and bit depths may be modified dependent upon actual geologic and borehole conditions encountered during the drilling/completion operation. Final depths will be reported in the well completion report.

3B.7 Well Design and Construction

The subsurface and surface design (casing, cement, and wellhead designs) reflects minimum requirements to sustain the integrity of the borehole and well, and prevent the verification well from acting as a conduit for the movement of fluids up or down in the wellbore. For reasons such as equipment or supply availability, or changes to the supplemental monitoring program, the final well design will meet or exceed these requirements in terms of strength and CO₂ compatibility.

The wellbore trajectory of each of the deep wells (injection, verification, and geophysical wells) will be tracked. The wells will be drilled to an inclination standard that will eliminate the risk of interception with adjacent wellbores and surveyed at least every 1,000 feet to ensure compliance. Wells are planned to be held to less than 5 degree inclination.

Note that depths given are based on anticipated drilling conditions and estimated depths of formations and are subject to change. Final depths will be reported in the well completion report.

3B.7.1 Wellbore Diameters and Corresponding Depth Intervals

Table 3B-2 summarizes the open hole, drilled hole diameters and depths based on the hole size desired at TD and planned drilling and testing. Setting surface pipe to between 300 - 400 feet is expected to be well below the lowermost USDW so that all shallow groundwater that may potentially be used for domestic or commercial use is protected. The depth of the intermediate string is planned for the upper section of the Eau Claire to reduce the time the drilling mud is in contact with the shallower zones from 350 - 5,300 feet. At this time, routine drilling operations are expected; however, if this changes, intermediate casing may be run at a different interval.

Table 3B-2: Open hole diameters and intervals

| Name | Depth Interval (feet) | Open Hole Diameter (inches) | Comment |
|--------------|-----------------------|---|-----------------|
| Surface | 0 - 350 | 17 ½ or larger | To bedrock |
| Intermediate | 350 – 5,300 | 13 ½ or 12 ¼ or to accommodate the appropriate casing size(s) | To primary seal |
| Long String | 5,300 – 7,250 | 8 ½ or 8 ¾ | To TD |

Note 1: Estimates given based on anticipated drilling conditions and depth of formations; permit request is up to 8,000 ft or up to 150 ft into the Precambrian granitic basement.

3B.7.2 Casing

The designed life of this well is for the life of the project and any subsequent monitoring period. The casing will be protected on the outside by the cement sheath and will have limited exposure to well fluids. As a result, all casing strings are designed as carbon steel except for the bottom portion of the long string (from approximately 5300' to TD) where a chrome alloy casing is planned.

Corrosion of carbon steel casing is not expected during the life of this well. However, the potential for corrosion of casing material in the verification well will be addressed by using CO₂-resistant cement and time-lapse formation sigma log monitoring described in Section 6B.3. Should monitoring show that corrosion has become an issue and it will negatively impact zones above the primary seal, a contingency plan will be developed to address the issue, up to and including plugging and abandonment of the well, as per Section 8B.

The current casing design calls for three casing strings as outlined below. The casing strings specified below are listed as minimum performance requirements.

Table 3B-3: Casing Specifications

| Name | Depth Interval (feet) | Outside Diameter (inches) | Inside Diameter (inches) | Weight (lbm/ft) | Grade (API) | Design Coupling (Short or Long Threaded) | Thermal Conductivity @ 77 °F (BTU/ft.hr. °F) |
|---------------------------|-----------------------|---------------------------|--------------------------|-----------------|-------------------|--|--|
| Surface | 0-350 | 13 ¾ or 16 | 12.515 | 54.5 +/- | K55 or J55 | Long or short | 29.02 |
| Intermediate ¹ | 0-5,300 | 9 ⅝ | 8.835 | 40 | K55 or J55; N80 | Long or short | 29.02 |
| Long ² | 0 – 7,250 | 5 ½ | 4.950 | 17# | J55; Chrome Alloy | Long or short | 29.02 |

Note 1: K55 or J55 to 1,200 feet; N80 to 5,300 feet.

Note 2: J55 from surface to 5,300 feet; chrome alloy (e.g., 13Cr80) from 5,300 feet to total depth.

Other Casing

No other casing strings are planned.

3B.7.3 Tubing

The verification well will be completed with a combination of tubing strings. The Westbay System is primarily stainless steel components and will be deployed on a special stainless steel tubing (2 ½” OD) in the monitoring zones with proprietary connectors from the lowermost perforation to the uppermost Westbay packer at approximately 5,500 ft. From there the tubing will be changed to 2 ⅞” API 6.5# production tubing (carbon steel)

The production tubing will go from surface to approximately 5,500 ft or within 200 ft of uppermost perforation and Westbay sampling port. Current plans call for a gas lift to be placed in the tubing at approximately 1,000 ft. If implemented, a stainless steel tubing of ¼-inch diameter will connect the gas lift valve to a nitrogen reservoir at the surface. Nitrogen gas will be injected into the production tubing via the gas lift valve to enable purging of the tubing during sampling operations.

The Westbay System consists of stainless steel tubing that extends from the bottom of the production tubing to the bottom of the well, and uses CO₂ resistant packers to create annular seals between the perforations (Table 3B-3). The Westbay MP55 packers are designed for use in borehole diameters ranging from 3.75” to 6.7”. They are manufactured from 316/316L stainless steel and incorporate a reinforced rubber gland made of Hydrogenated Nitrile Butadiene Rubber (HNBR) and a pressure balanced inflation/deflation valve mounted on a stainless steel mandrel. Details of the Westbay System are shown in Figure 3B-2, and described in more detail in this permit application under Section 6B, Monitoring, Integrity Testing and Contingency Plan.

Table 3B-3. Westbay MP55 Packer Dimensions and Weight

| Packer Specification | Dimension / Weight |
|--------------------------------|---------------------------|
| Overall Length (incl. Threads) | 63.1 inches |
| Gland Sealing Length | 34 inches |
| Outside Diameter | 3.5 inches |
| Inside Diameter | 2.26 inches |
| Drift | 2.17 inches |
| Dry Weight | 38 lbs |
| Submerged Weight | 30 lbs |

Table 3B-4. Tubing Specifications

| Name | Depth Interval (feet) ¹ | Outside Diameter (inches) | Inside Diameter (inches) | Weight (lbm/ft) | Grade (API) | Design Coupling | Thermal Conductivity @ 77°F (BTU/ft.hr.°F) |
|-------------------|------------------------------------|---------------------------|--------------------------|-----------------|-------------|-----------------|--|
| Production tubing | 0 - 5,500 +/- | 2 7/8 | 2.44 | 6.5 | J55 | EUE (min) | 29.02 |
| Westbay Tubing* | 5,500 - 7,250 +/- | 2 1/2 | 2.26 | 3.12 | 316L SS | Special | 9.246 |

* The Westbay System tubing and joints have a minimum yield strength of 22,000 lbs. All other Westbay components exceed this minimum yield strength. The air weight of the proposed Westbay tubing string will be 11,600 lbs.

Table 3B-5. Westbay System Components and Weight Specifications.

| Component Description | SWS (Westbay) Part No. | Quantity (est) | Dry Weight (lbs) | Wet Weight (lbs) |
|--|------------------------|----------------|------------------|------------------|
| 6.0 m SS tubing | 040160 | 130 | 63.3 | 55.0 |
| 3.0 m SS tubing | 040130 | 52 | 32.6 | 29.0 |
| 1.5 m SS tubing | 040115 | 1 | 17.3 | 15.0 |
| 1.0 m SS tubing | 040110 | 0 | 12.2 | 11.0 |
| SS Measurement Port (Sample Port) | 040500C1 | 27 | 11.1 | 9.7 |
| SS Hydraulic Sliding Sleeve (Pumping Port) | 043200C1 | 10 | 17.6 | 15.0 |
| SS End Cap | 040300C1 | 1 | 1.5 | 1.3 |
| SS Geopro Packer | 041400C1 | 27 | 38.0 | 30.0 |

3B.7.4 Cement

The casing strings will be cemented as outlined below:

Surface casing will be cemented back to surface; should fallback of more than 30 feet occur, a surface grout job will be performed.

The planned cement interval for the intermediate string is to cement back to surface; the performance standard applied to the intermediate casing will be to have cement into the surface pipe. Should this standard not be achieved a cement bond log and or temperature survey will be run shortly after cementing to locate the actual cement top. After notifying the permitting agency and conferring as to the remediation required, a plan will be developed. The most likely scenario is that the annulus between the surface casing and intermediate casing will be grouted and

pressure tested to insure hydraulic isolation. In any event, a Cement Bond Log with radial capability or Ultrasonic Cement Imaging logs will be run prior to running the long string casing.

On the long string the planned cement interval is from TD back to surface; CO₂ resistant cement will be used from TD through the Eau Claire. The performance standard applied to the long string will be to have at least 1,000 feet of cement into the bottom section of the intermediate casing. Should this standard not be achieved, a cement bond log and/or temperature survey will be used to establish the cement top. The permitting agency will be notified immediately and discussions will occur as to the best method to remediate. Options would include grouting, top filling from the surface where cement would be pumped into the annulus until annulus is “topped out”, or perforating above the cement top and attempting to circulate cement from the cement top. Perforations would then have to be squeezed off and pressure tested to 1,000 psi with no leak off. In any event, a Cement Bond Log with radial capability or Ultrasonic Cement Imaging logs will be run prior to the well completion.

Note that the cementing programs provided in Table 3B-6 are estimates, and may be adjusted as a result of hole conditions, depths, etc.

Table 3B-6: Cement Specifications for Verification Well #2

| Name | Depth Interval (feet) | Type/Grade | Additives | Quantity (cubic feet) | Circulated to Surface | Thermal Conductivity (BTU/ft.hr. °F) |
|--------------|-----------------------|---|--|----------------------------|-----------------------|--------------------------------------|
| Surface | 0 - 350 | Class A | Accelerator, LCM | 425 | Yes | 0.73 |
| Intermediate | 0 - 5,300 | Lead : 35:65 LP3:Class A Tail: Class A or H | Extender, antifoam, LCM Dispersant, fluid loss additive | 1784 (lead), 316 (tail) | Yes | 0.54(lead) 0.74(tail) |
| Long | 0 - 7,250 | 35/65 Lead; CO ₂ resistant tail | Antifoam, dispersant, fluid loss + antisetling (tail) | 1176 (lead), 656 (tail) | Yes | 0.75 |

Note 1: Surface casing: +/- 350 sks of Class A + additives. Density: 15.6 ppg, Yield: 1.20 cf/sk, Mix water: 5.23 gal/sk, Excess 75%

Note 2: Intermediate casing: Lead slurry +/- 910 sks of lead 65-35 Cement-Poz, 4% Gell, 10 % BWOW salt, + additives. Density: 12.9 ppg, Yield: 1.96 cf/sk, Mix water: 9.95 gal/sk. Followed by tail slurry: +/- 300 sks of Class A/H + additives. Density: 15.6 – 16.1 ppg, Yield: 1.10 - 1.19 cf/sk, Mix water: 4.97 – 5.234 gal/sk, Excess 30%.

Note 3: Long string casing: Lead slurry: +/- 600 sks cubic ft of 65-35:Cement-Poz + 6% extender + 10% salt BWOW + additives. Density: 12.5 ppg Yield: 1.96 cf/sk Mix water: 10.54 gal/sk; Excess 30% in O.H. and no excess inside intermediate. Followed by tail slurry: +/- 625 sks CO₂ resistant cement + additives. Density: 15.9 ppg, Yield: 1.05 cf/sk, Mix water: 3.012 gal/sk, Excess 30%

CO₂ resistant cement will cover the entire open hole section from TD and be placed approximately 500 feet back into the intermediate casing. Assuming the intermediate casing will be set approximately 50 feet into the Eau Claire, the CO₂ resistant cement will be about 450 feet above the Eau Claire.

Other Casing

There are no plans for additional casing strings at this time; however, depending on actual drilling conditions the well plan may be adjusted to accommodate unplanned events. The permitting agency will be notified prior to any casing additions.

Cementing Techniques, Equipment Positions, and Staging Depths

Casing centralizer design and placement will be performed for all casing strings to optimize casing centering and mud removal. Drilling and log data will provide well bore trajectory and hole size information and will be utilized in the design program.

The cement plan incorporates use of a one-stage cementing technique for each string if hole conditions allow. A casing float shoe will be placed on the bottom of the casing string and a float collar placed one joint of casing above the bottom. A bottom wiper plug will be used to wipe the mud film from the casing ahead of the cement job. The bottom of the casing will be set a few feet off the bottom of the hole. Actual cement pumping and displacement rates will be determined using well specific parameters such as mud properties and hole size learned during the actual drilling process and will utilize wireline surveys, including a caliper log. A custom spacer will be pumped ahead of the cement system to assist in mud removal.

Although single stage cement jobs are planned for all casing strings, information learned during the drilling process (e.g. lost drilling returns) and testing of the open hole (e.g. significant fractures identified via well logs) may lead to a decision to use a two-stage cementing technique on any or all of the strings. The intermediate casing for CCS #1 was performed in a two-stage operation. If a lost circulation zone is encountered in this verification well then the expectation would be that a two stage job would be required. The CCS #1 well's long string was successfully cemented back to surface in a single stage operation, however should a two-stage cement system be required for the long string, the lower cement stage will cover the Mt. Simon and Eau Claire and come up to a few hundred feet above the Eau Claire. A stage cementing tool will be run on the long string casing allowing the second stage or upper section to be cemented after the lower cement stage has reached approximately 500 psi compressive strength. The designed lead system will cover the upper hole section and a small amount of the CO₂-resistant cement may be tailed in and placed across the stage cementing collar. The stage cementing collar will be drilled out and casing integrity test performed.

Section 7.5.4 of this application includes a description of the CO₂-resistant cement. Appendix B has the complete manufacturer's specifications. Table 3B-7 below is the manufactures specifications for the specific density planned for lower portion of the injection casing cement.

Table 3B-7: Manufacturers Specifications for Long String Casing Cement

| | |
|---|---------------------|
| BHCT (Bottomhole circulating temperature) | 40 °C [104 °F] |
| BHST (Bottomhole static temperature) | 50 °C [122 °F] |
| Specific gravity [lbm/gal] | 15.9 ppg |
| Rheological properties determined with API R1B5 after | |
| PV (cp) (Plastic Viscosity) | 454.623 |
| T _v (lbf/100ft ²) (Yield Point) | 28.45 |
| After conditioning at BHCT | |
| PV (cp) | 247.198 |
| T _v (lbf/100ft ²) | 28.16 |
| 10 second gel strength (lbf/100ft ²) | 22 |
| 10 minute gel strength (lbf/100ft ²) | 25 |
| Then 1 minute stirring gel strength (lbf/100ft ²) | 19 |
| Stability | OK no sedimentation |
| API fluid loss at BHCT | 0 |
| Thickening time at BHCT | |
| 30 Bc | 1hr, 46 min |
| 70 Bc (unpumpable) | 4 hr, 18 min |
| UCA cell compressive strengths* | |
| 50 psi | 18 hr, 29 min |
| 500 psi | 21 hr, 07min |
| 24 hour comp. strength psi | 1177 |

Perforation Depths

The verification well perforations are expected to be placed at seven intervals in the Mt. Simon formation in an attempt to more clearly understand how the injected CO₂ moves through the reservoir. Up to three intervals above the Eau Claire will also be perforated; fluid sampling and pressure monitoring in these zones will be used to measure pressure effects of injected CO₂ and monitor for any unexpected migration above the cap rock. While above the primary caprock seal, the open perforations will be at least four thousand feet below any USDW and approximately two thousand feet below the secondary seal (Maquoketa Formation).

Table 3B-1 lists an estimate of perforation depths for Westbay monitoring. Depths are based on the well logs from CCS #1; final perforations may change and will be reported in the well completion report.

3B.7.5 Annular Protection System

This section describes the annular protection system which monitors the annular space extending from the uppermost packer to the surface. Further information regarding the monitoring of annular space below the upper most packer can be found in Section 6B.3, Mechanical Integrity Tests During Service Life of Well.

The well will be constructed and operated in such a way to meet Federal requirements of 40 CFR Part 146 UIC Permit Program Subpart H, to establish and maintain mechanical integrity. The

surface and intermediate strings will be cemented to surface so there are no open annuli between these strings.

The long string casing will be filled with a brine with a density of 9.4 pounds per gallon. The brine will be present after the casing is installed and during completion of the monitoring system. The reservoir pressure gradient is 0.451 psi/ft (as determined in the CCS#1 well). The annulus will be bled and fluid will be replaced as needed until the entrained air is removed from the annulus. After the initial completion is installed the annulus between the production tubing string and the long string casing above the uppermost packer will be pressure tested to 300 psig for one hour with a maximum leakoff of not more than 3%. During the life of the well this same annulus will be pressure tested to 200 psig on an annual basis, again with a maximum of 3% leakoff allowed.

The annulus between the production tubing and the long string casing will be monitored at the surface for the absence of significant pressure changes (pressure rise due to fluid entering annulus or vacuum due to fluid loss). The uppermost packer will be located above the uppermost perforation expected to be in the lower Potosi formation, several thousand feet below the lowermost USDW and several hundred feet below the secondary seal of the Maquoketa Formation. The annulus fluid's hydrostatic gradient is greater than the pre-injection pressure of any of the perforated intervals. A change in pressure that exceeds an increase of 100 psi or a vacuum of 203 inches Hg (representing an equivalent fluid change of about 100 feet) can be construed as evidence of loss of integrity and would trigger an investigation. If leakage were to occur during the life of the well and CO₂ laden fluid were to rise past all the Westbay packers then a positive pressure would develop on the annulus due to CO₂ gas being liberated from the fluid as it migrates upward. Similarly, if fluid were lost, then a vacuum would develop. The annular pressure gauge will monitor both conditions.

3B.7.5.1 Annular Space

With regard to the annulus protection system, the annulus of the well is defined as the volume above the uppermost packer and the surface. The space will be the annulus between the production tubing and the 5 ½-inch OD long string casing.

3B.7.5.2 Type of Annular Fluid(s)

The annulus above the upper packer will be filled with a NaCl or equivalent completion brine with a density of approximately 9.4 ppg.

3B.7.5.3 Specific Gravity of Annular Fluid(s)

The annulus between the long string casing and production tubing is expected to contain approximately 9.4 ppg completion fluid. The specific gravity will be approximately 1.11–1.12. Actual densities will depend upon the highest formation gradient encountered. Annular fluid gradient will be greater than the largest encountered fluid gradient.

3B.7.5.4 Type of Additive(s) and Inhibitor(s)

Completion fluid will contain corrosion inhibitors.

3B.7.5.5 Coefficient of Annular Fluid(s)

The well is expected to have a minimum of 0.488 psi/ft gradient (coefficient) in annulus or at least 0.1 ppg over and above normal water specific gravity or psi/ft. on depth of packer placement.

3B.7.5.6 Packer or Fluid Seal

The verification well will be completed using a Westbay system . The system contains a series of packers used to isolate discrete intervals within the wellbore. Completion brine or Mt. Simon formation brine will be in the annulus and between all the Westbay packers. Above the uppermost Westbay packer, the annular space will be filled with a 9.4 ppg completion brine. There will be a dedicated pressure gauge at the wellhead to monitor the casing/tubing annulus.

3B.8 Information on Well Drilling Company Used During Construction

Drilling Firm Information

A drilling contractor has not yet been selected. This decision will be based on rig availability and the final decision of project management regarding procurement. Details about the drilling contractor will be provided in the well completion report.

3B.8.2 Drilling Schedule

The preliminary well construction (drilling & completion) schedule and additional details are included as Figure 3B-6. Utilization of a single drilling rig to sequentially drill the injection, verification, and geophone wells is aimed towards providing the best consistency and quality of the many services required for drilling wells.

3B.8.3 Drilling Method

A rotary drilling rig will be used. The expected rig will be of a minimum rating to drill to expected depth and handle designed casing loads as well as have the set-back capacity adequate to drill a well to this depth. Blow Out Preventers (BOP) will be used in the unexpected event of an interval or zone having higher pressure than anticipated. The mud system will be designed to maintain overbalanced drilling.

3B.9 Tests and Logs

ADM will provide a schedule for all testing and logging to the permitting agency at least 30 days in advance of conducting the first such tests and/or logs.

3B.9.1 During Drilling

With the exception of the surface pipe interval, each open hole section (prior to setting each casing string) will be logged with multiple suites to characterize the geologic formations (reservoirs and seals). At a minimum, all wireline runs will have resistivity, spontaneous potential (SP), gamma ray (GR) and caliper logs. Sonic and porosity logs additionally will be included on the intermediate and TD run. The TD run will also include magnetic resonance, micro-imaging (dipmeter and fracture ID), formation pressure and rotary cores. Cement imaging logs will be run on the intermediate casing string. A cement evaluation log is not planned on the surface casing if cement is returned to surface with no fallback and if surface casing shoe test is successful. Whole core may also be acquired during drilling.

3B.9.2 During and After Casing Installation

Based on previous analysis and results in the area, stimulation will not be required.

Cement bond logs and/or cement imaging logs will be run on the long string.

Pressure Transient Analysis methods may be used to garner additional permeability information. To obtain the necessary data an injection or pumping test may be performed.

3B.9.3 Demonstration of Mechanical Integrity

Cement and system mechanical integrity will be verified with cement imaging logs with a radial capability (e.g. Schlumberger Slim Cement Mapping Tool (SCMT), UltraSonic Imaging Tool (USIT), etc).

A baseline reservoir saturation tool (RST) and temperature log will be run to be available for comparison with subsequent passes for detailed knowledge of where the injected CO₂ may have moved vertically. The 2 7/8-inch tubing by 5 1/2 inch casing annulus above the uppermost packer will be pressure tested to establish mechanical integrity.

The blank zones between perforations are referred to as “QA Zones” (Quality Assurance Zones). Each QA Zone consists of two packers and the blank (not perforated) casing between them. Having no connection to the formation, pressure data from such zones can be used to document the continued sealing performance of the packers. The presence of a persistent measurable pressure difference across a packer indicates the presence of a positive annular seal.

The pressure data collected from all of the perforated zones and the QA zones will be used to provide baseline data, and will be compared to the pre-inflation profiles to help document the presence of seals between perforations in the annular space. Preliminary testing in the QA zones will also provide baseline data.

QA Zones will be established to provide redundant quality assurance monitoring. At least two QA zones are planned above the uppermost Mt. Simon port, giving a total of five seals to prevent vertical migration of fluid in the annulus. These QA zones will be particularly important for confirming the presence of annular seals between the injection horizon and the overlying stratigraphic units.

3B.9.4 Copies of the Logs and Tests Listed Above

The logs and tests listed above will be conducted during well construction and copies of these logs will be included in the well completion report provided to the permitting agency.

3B.10 References

Frommelt, D., 2010. Letter to the Illinois Environmental Protection Agency, Subject: CCS Well #1 Completion Report, Archer Daniels Midland Company – UIC Permit UIC-012-ADM, dated May 5, 2010.

Figure 3B-1: Verification Well location diagram.

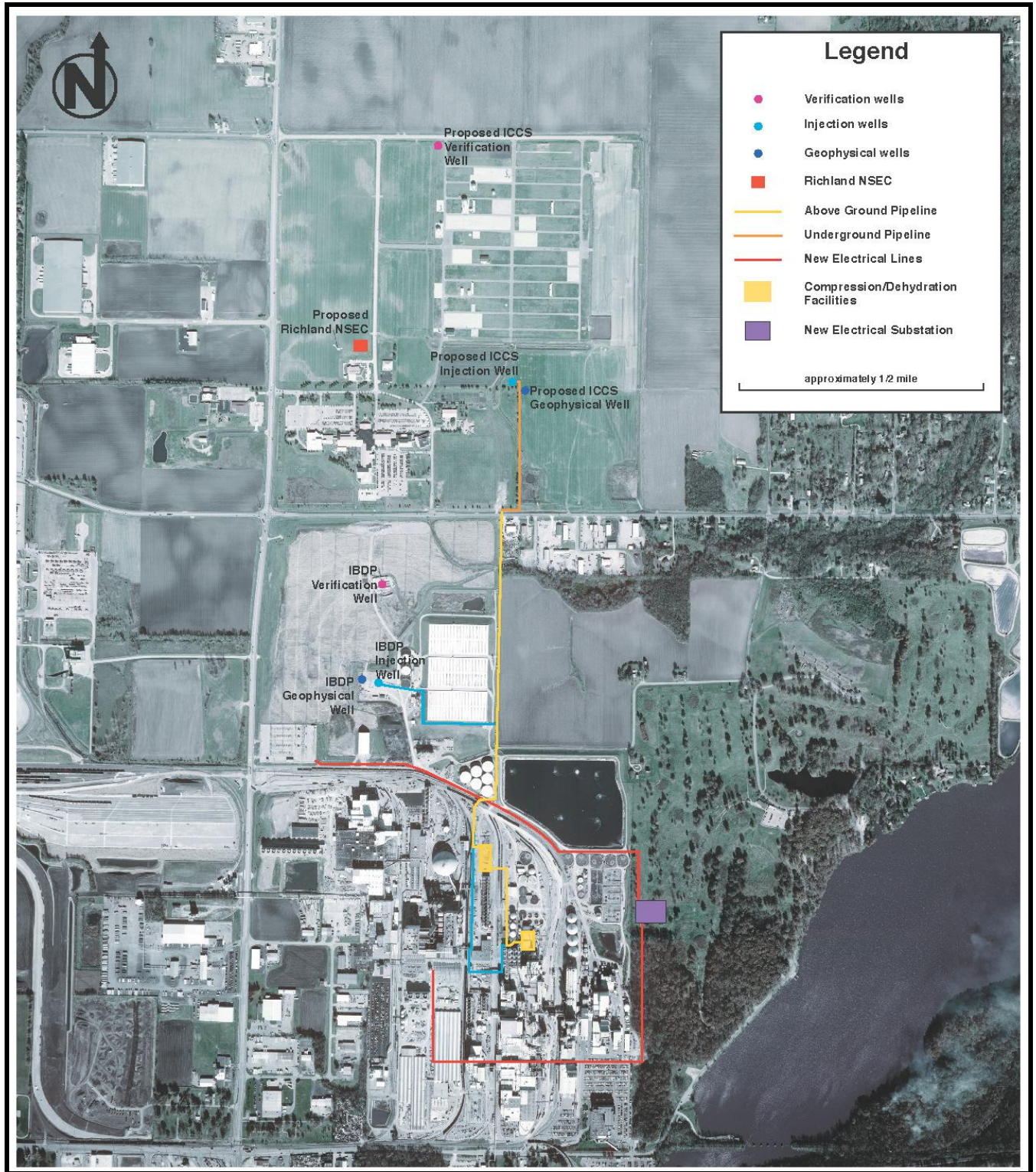

Figure 3B-2: Verification Well Schematic

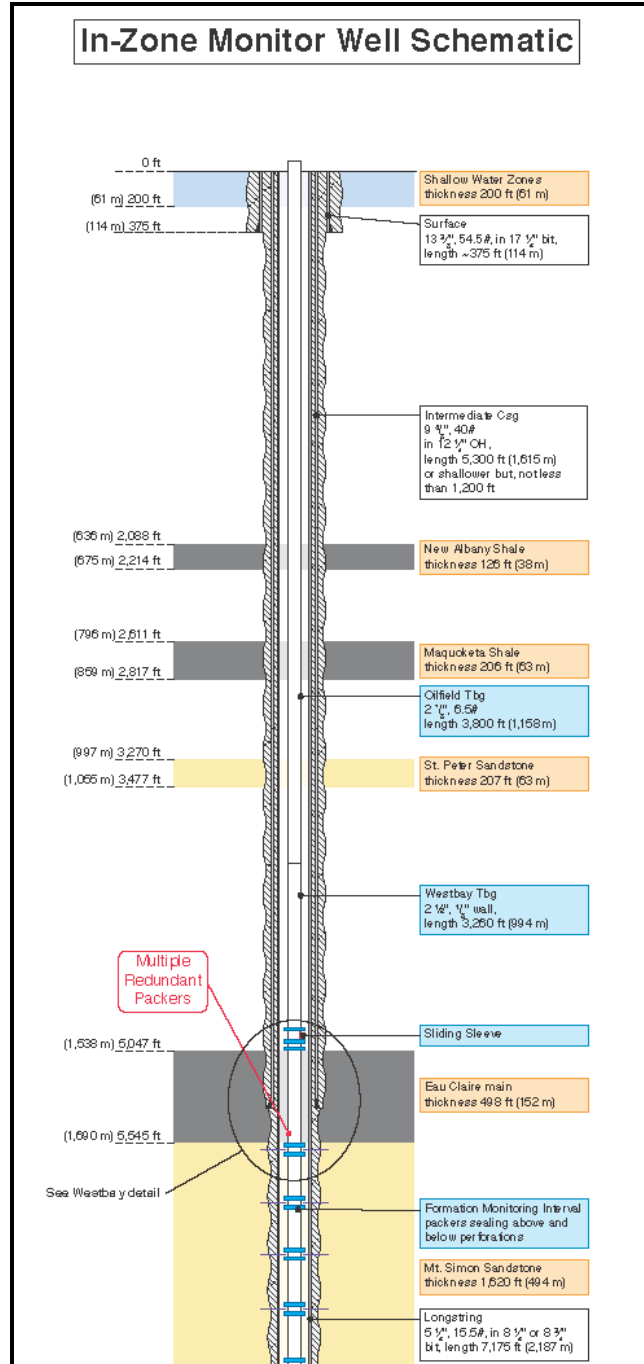

Figure 3B-3: Detail of a part of the Westbay System from Figure 3B-2.

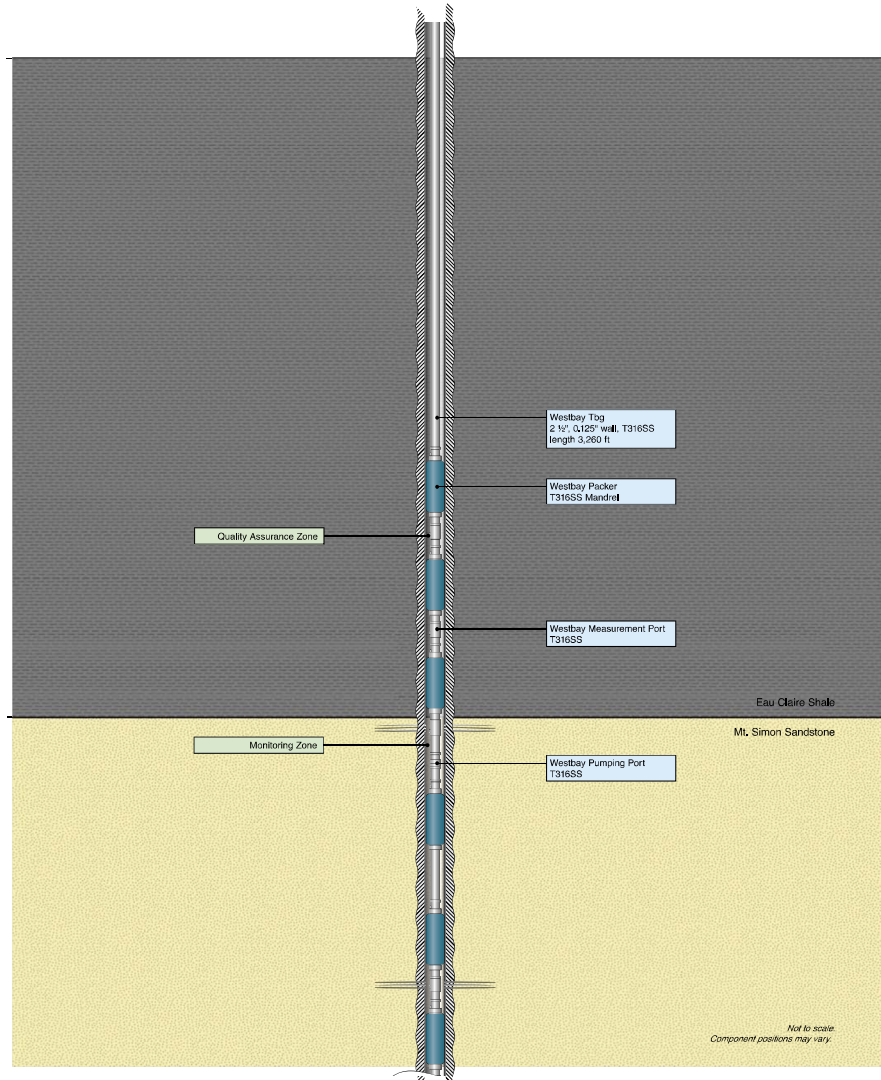

Figure 3B-4: Verification Wellhead Schematic

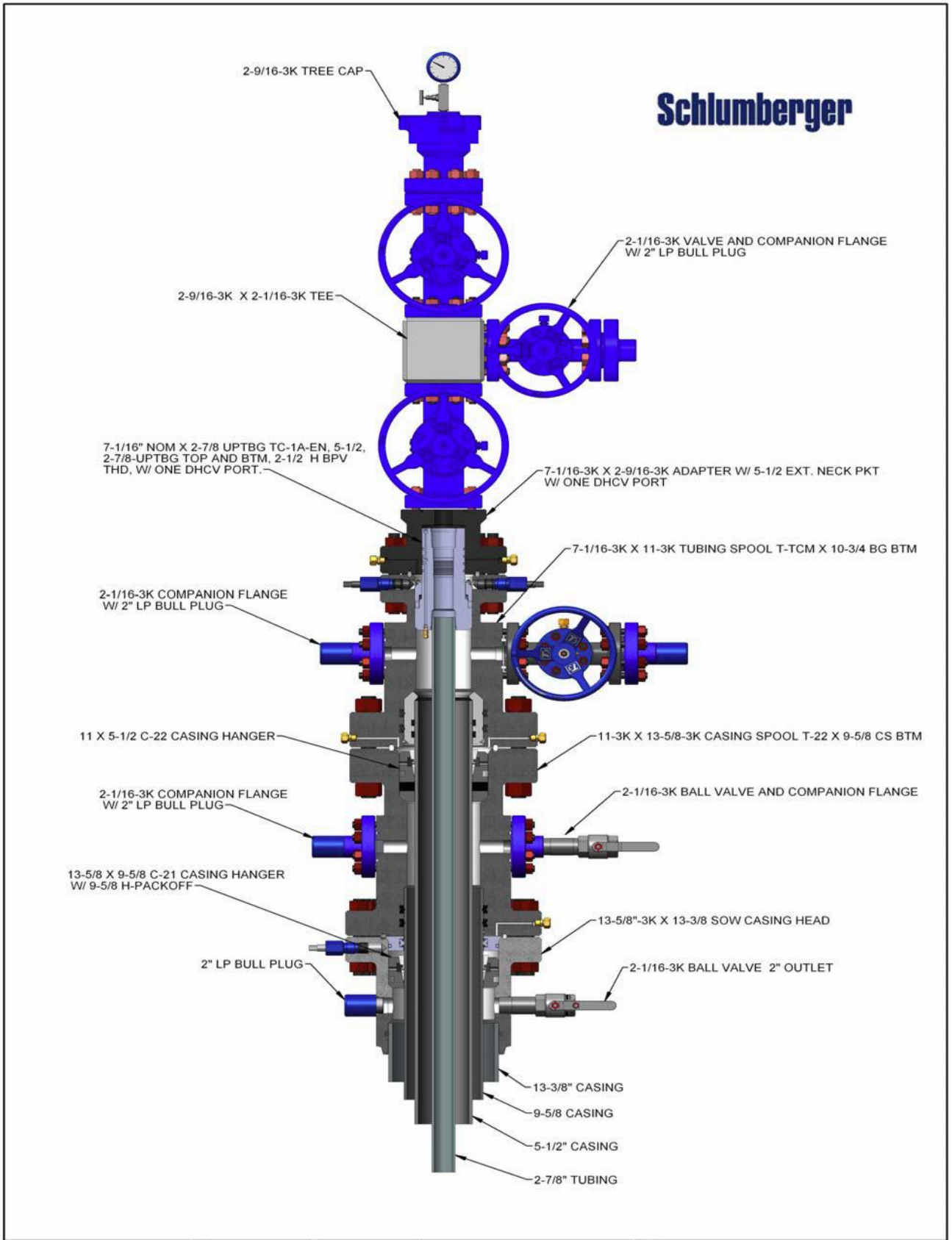
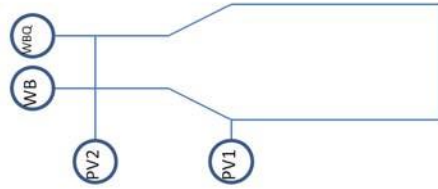

Figure 3B-5: Verification Well Instrumentation Schematic and Summary

Note 1 - Equipment is not ordered yet



| Description/Location | ADM Tag | Measurement | Brand | Model | Service | Compatibility with Fluid | Range Maximum >20% | Operating Range | Instrument Range Maximum | Operating Range Units | Measurement Required for Permit Compliance | Activates Automated Equipment Shutdown |
|--|---------|-------------|---------|---------|---------------------|--------------------------|--------------------|-----------------|--------------------------|-----------------------|--|--|
| Annular pressure gauge | PV1 | Pressure | Topac | Note 1 | Dry CO ₂ | Yes | Yes | 14 – 115 | 0 – 150 | psia | Yes | No |
| Tubing Pressure | PV2 | Pressure | Topac | Note 1 | Dry CO ₂ | Yes | Yes | 14 – 115 | 0 – 150 | psia | Yes | No |
| Westbay pressure measurement system for reservoir (10 zones) | WB | Pressure | Westbay | Saphire | Dry CO ₂ | Yes | Yes | 1,000 – 3,500 | 0 – 5,000 | psia | No | No |
| Westbay QA zone monitoring | WBQ | Pressure | Westbay | Saphire | Dry CO ₂ | Yes | Yes | 1,000 – 3,500 | 0 – 5,000 | psia | Yes | No |

Figure 3B-6. Drilling Schedule and Tasks

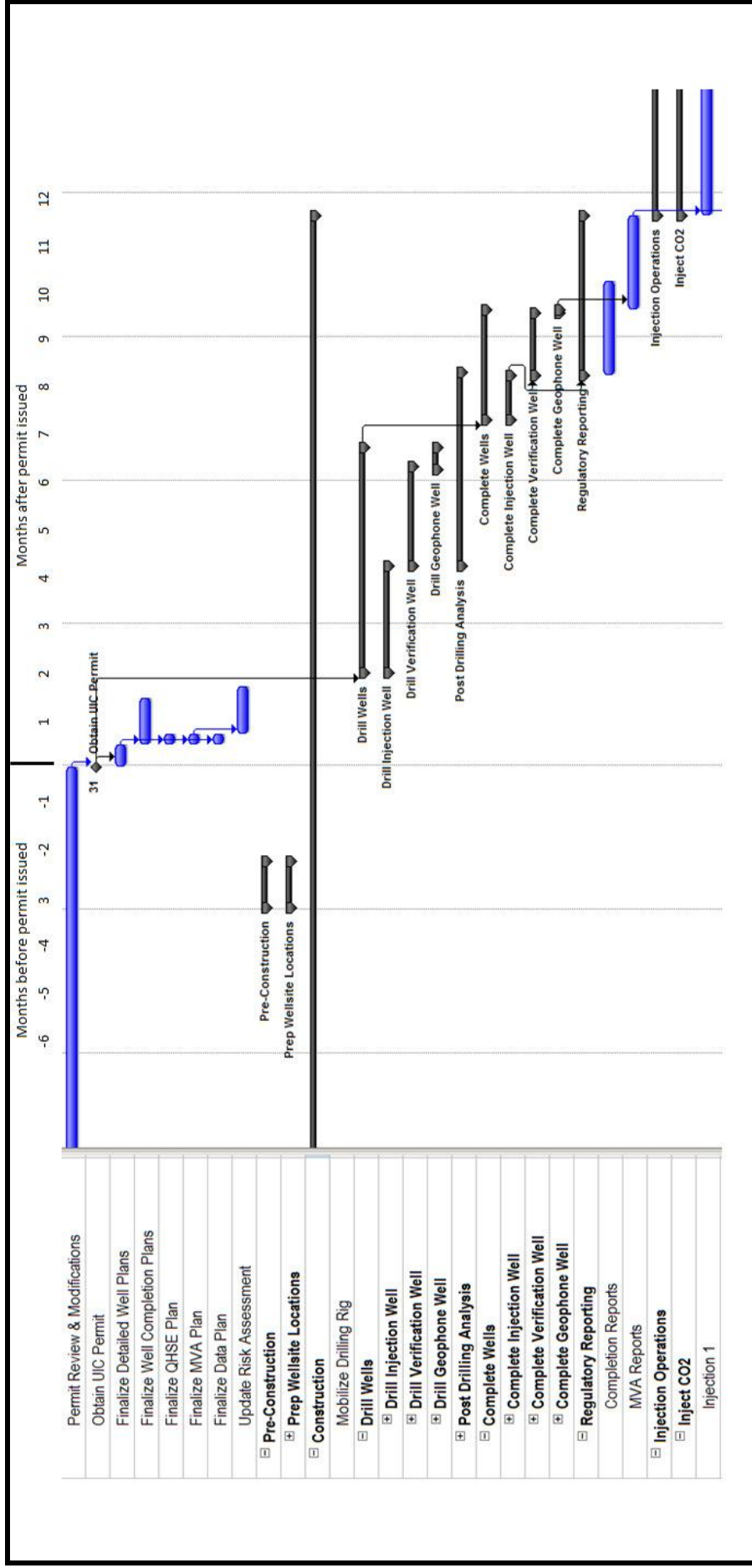

SECTION 3C – GEOPHYSICAL WELL DESIGN AND CONSTRUCTION DATA

This section provides information on the construction of a Geophysical Monitor Well in order to provide geophysical monitoring of the CO₂ plume resulting from nearby injection. A Geophysical Monitor Well will allow for the use of a downhole geophone array and controlled acoustic energy at the surface to image the substructure to effectively monitor the CO₂ plume growth in the Mt. Simon reservoir. This technique, known as Vertical Seismic Profiling (VSP), has been successfully deployed in the IBDP and other demonstration projects around the world, such as the Saline Aquifer CO₂ Storage project in Norway (a.k.a. Sleipner), the CO₂CRC Otway Project in Australia, and the Frio Brine Pilot Experiment in Texas, USA.

The Geophysical Monitoring well is also intended to provide a means for monitoring of downhole formation pressure in the St. Peter Sandstone. The St. Peter is known as a porous and permeable interval that lies above the Mt. Simon CO₂ injection interval and also lies below the lowermost USDW.

Should pressure data indicate unexpected changes in the wellbore, the Geophysical Monitoring Well will also provide a means to obtain St. Peter reservoir fluid samples and indirect measurements such as Pulsed Neutron/Sigma logs (e.g. Schlumberger Reservoir Saturation Tool) across the shallower formations (from St. Peter and above) to verify whether or not any CO₂ leakage from the nearby injection operation is occurring.

The Geophysical Monitor Well will be drilled within 500 feet of the proposed IL-ICCS injection well and will be located in Section 32, Township 17N, Range 3E, Macon County, Illinois. The planned well name is “Geophysical Monitoring Well #2”.

3C.1 Well Depth

The well design consists of setting a string of 9-5/8 inch (or smaller) surface casing into the bedrock, below potential shallow groundwater resources, at a depth of approximately 350 feet. Surface casing will then be cemented back to the surface. The final section of the hole will be drilled through the surface casing with an 8-1/2 inch or similar bit size to a depth of 3,500 feet, approximately 80 feet below the base of the St. Peter Sandstone, in order to achieve the desired vertical seismic image. Utilizing the drilling rig, a final string of 4-1/2 inch casing will be run to the total well depth. A permanent geophone array is planned to be mounted on the outside of the long string casing and cemented in place. Another option would be to utilize a geophone array inside the casing on an as needed basis. The final design will be determined prior to well construction and will be detailed in the well completion report. The casing annulus will be cemented from total depth to inside the surface casing, at a minimum (see Figure 3C-1). The well will be perforated near the bottom of the well (approximately 3,400 feet) in the base of the St. Peter Sandstone.

3C.2 Anticipated Fracturing Pressure – N/A

3C.3 Static Water Level and Type of Fluid – N/A

3C.4 Expected Service Life of Well

The expected service life of the well is projected to be at least 30 years.

3C.5 Well Completion

The well will be cased to total depth (TD), and each string will be cemented to the surface to prevent movement of fluids along the borehole and outside of the casings. The well will be perforated in a single zone at the bottom of the well to monitor pressure changes in a permeable zone above the CO₂ injection zone and much deeper than the lowermost USDW.

3C.6 Schematic or Other Appropriate Drawing of the Surface and Subsurface Construction Details of the Well

A schematic showing subsurface construction details of the geophysical well is found in Figure 3C-1. Casing and bit depths may be modified dependent upon actual geologic and borehole conditions encountered during the drilling/completion operation. Final depths will be reported in the well completion report.

3C.7 Well Design and Construction

3C.7.1 Well Hole Diameters and Corresponding Depth Intervals

Surface casing will have a diameter of 9-⁵/₈ inches or smaller. The long string casing will have a diameter of 4-¹/₂ inches.

3C.7.2 Casing

Surface Casing: 9-⁵/₈ inch (or smaller), 40 lbm/ft surface casing J55 short thread & coupling, in 12-1/4 inch open hole to approximately 350 feet. Thermal conductivity 29.02 BTU/ft-hr °F.

Long String: 4-¹/₂ inch, 10.5 lbm/ft EUE 8-rd casing in 7-⁷/₈ inch to 8-¹/₂ inch open hole to total depth of approximately 3,500 feet. Thermal conductivity 29.02 BTU/ft-hr °F.

3C.7.3 Cement

Surface Casing: Cement to surface using 60% excess (approximately 150 sacks) of Class A cement with appropriate additives. Weight: 15.6 ppg and yield 1.19 cf/sack. Casing to be run centralized with a guide shoe and float collar.

Long String: Cement well using 25% excess of expanding cement mixed at 14.2 ppg and yield of 1.58 cf/sack. Long string casing to be run centralized with a float collar and float shoe. Actual borehole geometry will be used to determine appropriate cement volume and centralizer placement.

3C.7.4 Annular Protection System - N/A

3C.8 Information on Well Drilling Company Used During Construction

Drilling Firm Information

A drilling contractor has not yet been selected. This decision will be based on rig availability and the final decision of project management regarding procurement. Details about the drilling contractor will be provided in the well completion report.

Drilling Schedule

The preliminary drilling schedule and additional details are included as Figure 3C-2. Utilization of a single drilling rig to sequentially drill the injection, verification, and geophone wells is planned and will provide the best consistency and quality of the many services required for drilling wells.

Drilling Method

A rotary drilling rig will be used. The expected rig employed will be of sufficient capacity to drill a well to the expected total depth. Blow Out Preventers (BOP) will be used in the unexpected event of an interval or zone having higher pressure than anticipated.

3C.9 Tests and Logs

3C.9.1 During Drilling

With the exception of the surface pipe interval, each open hole section (prior to setting each casing string) will be logged with multiple suites to characterize the geologic formations (reservoirs and seals). At a minimum, the following tests and logs will be run: Drilling Log, Laterlog/SP/Micro Resistivity/GR, Compensated Neutron/Litho Density/GR/ Caliper.

3C.9.2 During and After Casing Installation

After the long string of casing has been installed, a cement imaging log will be run with gamma ray and casing collar locator.

The well will be perforated across a short interval (one to two feet) near the base of the St. Peter Sandstone and below the position of the lowermost geophone.

Fluid samples from the monitor zone will be taken during the initial completion of the well. After perforating, formation fluid from the St. Peter will be temporarily produced by swabbing the well. (Swabbing is a common technique used to unload liquids from the production tubing to initiate flow from the reservoir. A swabbing tool string incorporates a weighted bar and swab cup assembly that are run in the wellbore on heavy wireline. When the assembly is retrieved, the specially shaped swab cups expand to seal against the tubing wall and carry the liquids from the wellbore. Reference: Schlumberger oilfield glossary: <http://www.glossary.oilfield.slb.com>). The final sample will be taken after the zone has been produced by swabbing long enough to eliminate contaminants introduced during drilling. Measurements of electrical conductivity, pH, and fluid density will be performed during the sampling. The final sample results will be used as a baseline for the monitored interval in the event that further sampling is ever required.

A baseline Pulsed Neutron / Sigma log (Schlumberger's Reservoir Saturation Tool, RST) and a Temperature Log will be run at this time.

A baseline VSP (Vertical Seismic Profile) will be acquired prior to CO₂ injection on CCS #2. This survey will be used comparatively against future VSP's to monitor the spatial and vertical growth of the CO₂ plume developed by injection into the Mt. Simon Sandstone. The survey will be capable of imaging the formations which are deeper than those penetrated by the Geophysical Monitor #2 well.

The formation pressure of the monitor zone will be determined by recording the fluid level in the well at least weekly. The fluid level is expected to be at a depth of less than 500 feet in the wellbore. The fluid level and/or formation pressure is expected to be static.

A subsequent RST log and Temperature log can be acquired if an anomaly in the monitoring well or injection well is detected.

Subsequent fluid sampling can be performed and is only planned if a fluid level anomaly in the geophysical monitoring well is detected.

3C.9.3 Demonstration of Mechanical Integrity – N/A

3C.9.4 Copies of the Logs and Tests Listed Above

The logs and tests listed above will be conducted during well construction and copies of these test reports and logs will be included in the well completion report provided to the permitting agency.

Figure 3C-1: Geophysical Monitoring Well Schematic

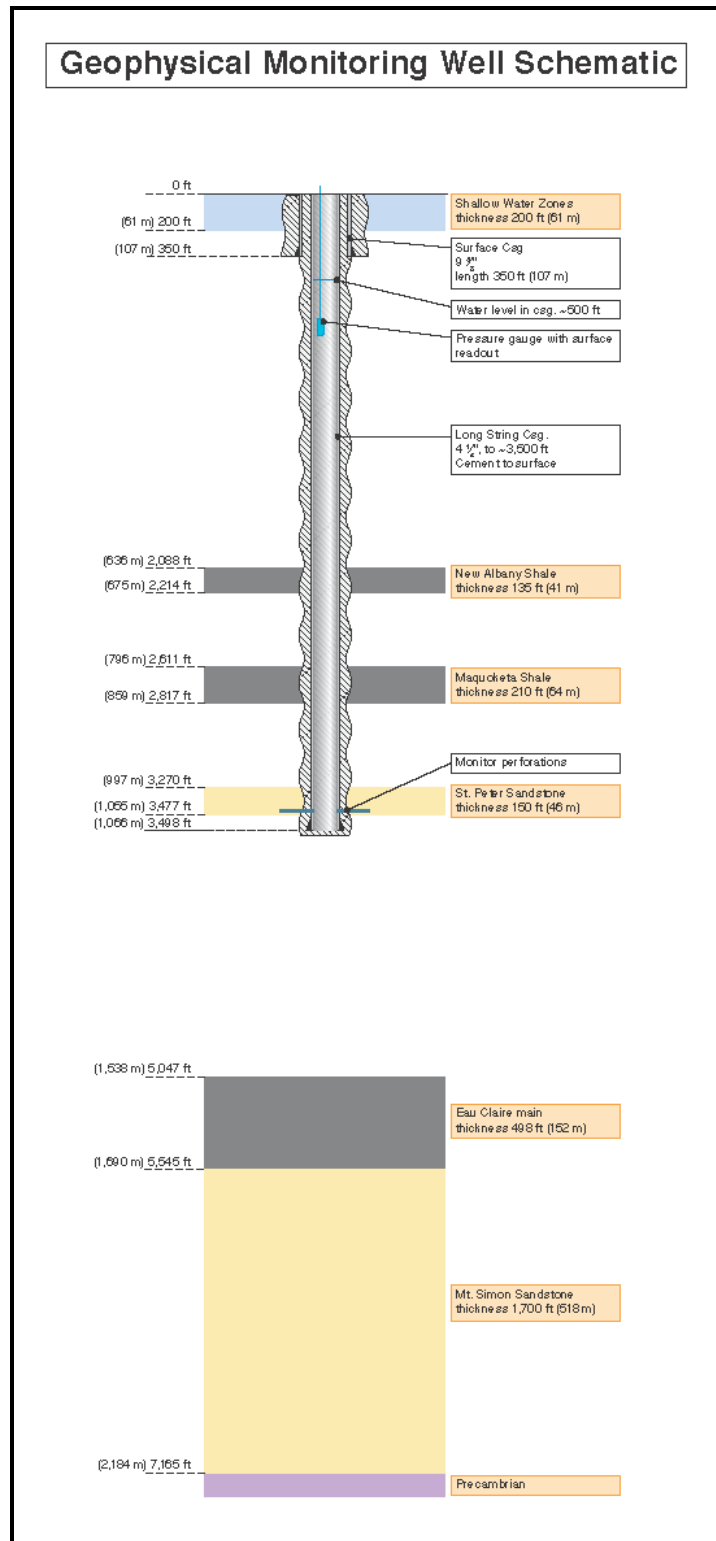
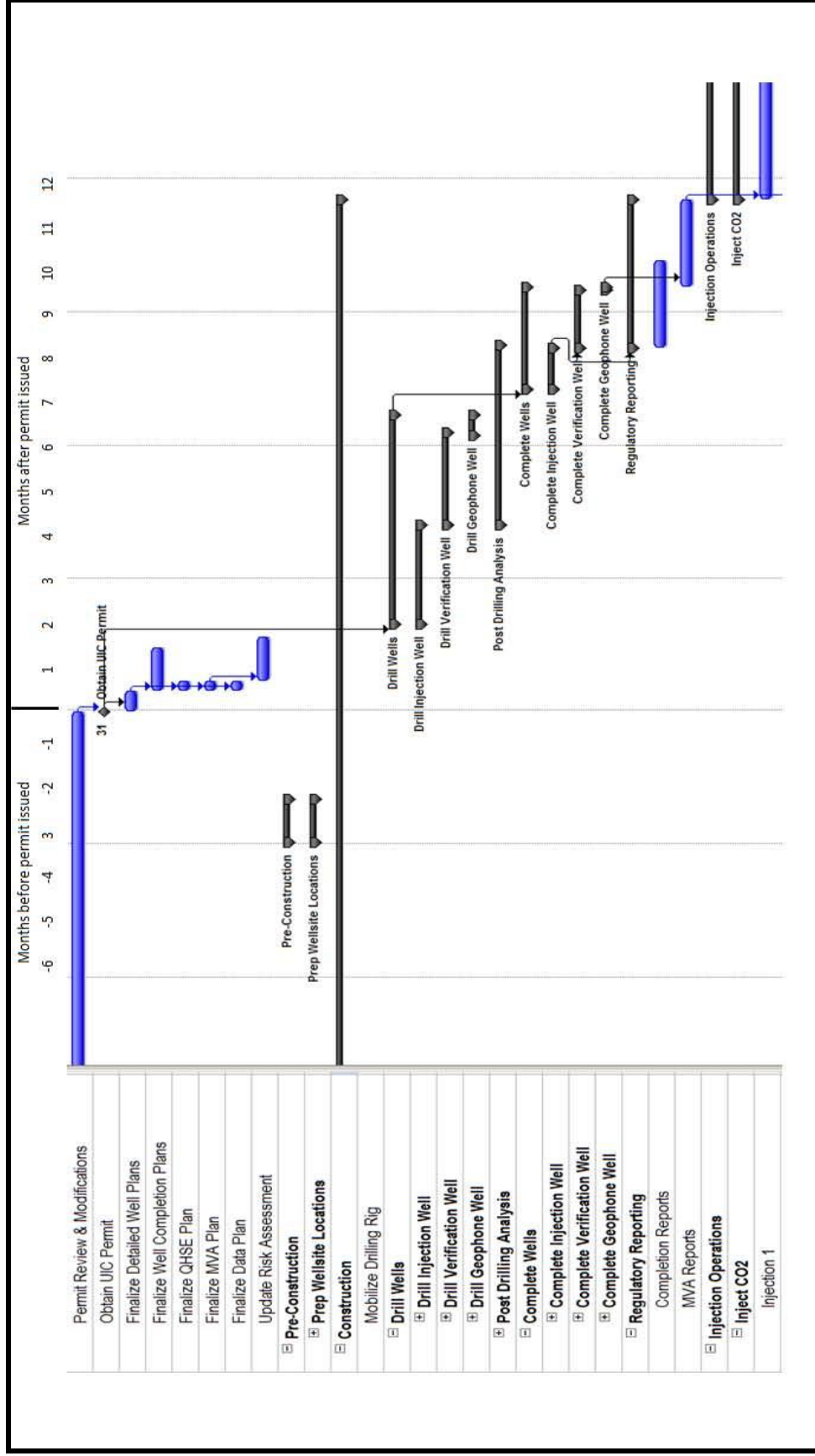

Figure 3C-2: Preliminary Well Drilling and Completion Schedule



SECTION 4 - OPERATION PROGRAM AND SURFACE FACILITIES

4.1 Operation Program

4.1.1 Number or Name of Well

The IL-ICCS project injection well will be named CCS #2.

The IL-ICCS project verification well will be named Verification Well #2, and the IL-ICCS project geophysical well will be named Geophysical Monitor Well #2.

The well names are similar (except for use of #2 instead of #1) to the well names used in the Illinois Basin – Decatur Project (IBDP).

4.1.2 Location

Injection well CCS #2 location is as follows:

Section 32, Township 17N, Range 3E of 3rd Principal Meridian.

Latitude: N 39° 53' 8" (N 39.88577°)

Longitude: W 88° 53' 19" (W 88.88883°)

4.1.3 Expected Service Life

The expected service life of the well is 30 years. Currently, the operator is planning for a 5-year injection (operational) period. Therefore, if the operator elects to continue injection past the 5-year schedule, the facility could operate an additional 25 years subject to 40 CFR 146.

4.1.4 Injection Rate, Average and Maximum

The compression and dehydration system is designed for a normal operating capacity of 3,000 metric tons (MT) per day with a maximum operating capacity of 3,300 MT per day. A custody transfer flow measurement device will be installed on the CO₂ transmission pipeline between compression and dehydration facility and the injection wellhead. The flow meter will produce a direct reading of total amount of injected CO₂ in units of mass per unit of time.

The average injection rate will be 2,800 MT per day over the project's 5-year life (average of 2,000 MT per day for the first year and 3,000 MT per day for remaining years). Based on the design of the compression and dehydration equipment, the facility will have a maximum injection capacity of 3,300 MT per day.

Over the life of the project, approximately 4.75 million MT of CO₂ will be injected into the Mt. Simon Sandstone. Current site modeling predicts the CO₂ plume produced from the IL-ICCS project as well as the plume from the nearby IBDP project will be retained within the Mt. Simon Sandstone. Section 5 of this application contains illustrations generated from the site models. These illustrations show the location and extent of the CO₂ plumes for both projects.

4.1.5 Anticipated Total Number of Injection Wells Required

It is anticipated that one injection well of appropriate design is required for injection of the maximum daily rate of CO₂.

There is another injection well – the IBDP injection well, CCS #1 – operating at the ADM site. This well is currently operating under permit No. UIC-012-ADM, but is not part of the proposed IL-ICCS project.

During this project, ADM plans to operate two injection wells for a period of time (est. 1-year). CCS #1, which is operating under State of Illinois permit, No. UIC-012-ADM, will be injecting CO₂ at an operational capacity of 1,000 MT per day with a maximum capacity of 1,100 MT per day. The location of this well is approximately 1 mile southwest of the proposed IL-ICCS CCS #2 well and the source of CO₂ is the ADM ethanol production facility. The CCS #2 well, for which this application has been prepared, will be supplied with CO₂ from the ADM ethanol production facilities at an initial operational capacity of 2,000 MT per day with a maximum capacity of 2,200 MT per day.

Following completion of the IBDP project's injection period, which is estimated to be the first quarter of 2014, the IL-ICCS project will assume operation of the IBDP compression facility and will increase the project's operational injection capacity by 1,000 MT per day with a maximum capacity of 1,100 MT per day. Thus, the total amount of CO₂ that can be supplied to injection well CCS #2 will be 3,000 MT per day operational capacity with a maximum capacity of 3,300 MT per day.

4.1.6 Number of Injection Zone Monitoring Wells

There are plans to drill and complete one injection zone (Mt. Simon) monitoring well (Verification Well #2) within approximately 3,000 feet north-northwest of the injection well (CCS #2). This well will be drilled to verify the location of the CO₂ within the Mt. Simon. Details regarding the verification well design and construction are included in Section 3B.

A geophysical (geophone) monitoring well (Geophysical Monitor Well #2) will be drilled and completed within 500 feet of the injection well. This well will be drilled in order to provide geophysical monitoring of the CO₂ plume. Details regarding the geophysical well design and construction are included in Section 3C.

A schematic of the injection, verification, and geophysical wells is provided as Figure 4-1. The drilling of all three (3) wells is planned to take place sequentially utilizing a single drilling rig. The completion of all three wells (injection, verification, and geophysical wells) will follow the conclusion of drilling operations. All wells will be drilled and completed prior to CO₂ injection into the CCS #2 well.

4.1.7 Injection Well Operating Hours

The injection well will operate continuously (24 hour per day, 7 days a week, and 365 days per year) during the permit period. The injection rate will vary between 0 and 3,300 MT per day for equipment maintenance, mechanical inspection, and testing subject to § 146.89 and § 146.90.

4.1.8 Injection Pressure, Average and Maximum

The operational injection pressure is estimated to be between 2,100 and 2,300 psi with an estimated maximum injection pressure of 2,380 psi. The higher pressure would be a result of lower Mt. Simon injectivity parameters. These pressure estimates are based on the design surface compression capacity of 3,000 MT per day (3,300 MT per day maximum) and the calculated injectivity of the Mt. Simon Sandstone developed from the IDBP project data using a 0.6435 psi/ft injection gradient (90% of the formation fracture gradient of 0.715 psi/ft).

4.1.9 Casing/Tubing Annulus Pressure, Average and Maximum

Because the injection tubing will be set in a packer above the injection interval within the Mt. Simon, the casing-tubing annulus space will be isolated from the CO₂ stream. A constant surface annulus pressure of 400 to 500 psig is anticipated during injection. The average and maximum are anticipated being about the same pressure; however, fluctuations in pressure are anticipated from changes in ambient surface temperature and injection tubing pressure.

All other annulus spaces (one between surface casing and intermediate casing, and one between intermediate casing and long string casing) will have cement to surface. Consequently the pressures of these annular spaces will be at atmospheric pressure.

Figure 4-1. Schematic of Injection Well, Monitoring (Verification) Well, Geophysical (Geophone) Well, and Detail of Monitoring System (Westbay System). Note: Packer location within the injection well will be set at a depth that will allow for the maximum CO₂ injection rate of 3,300 MT/day.

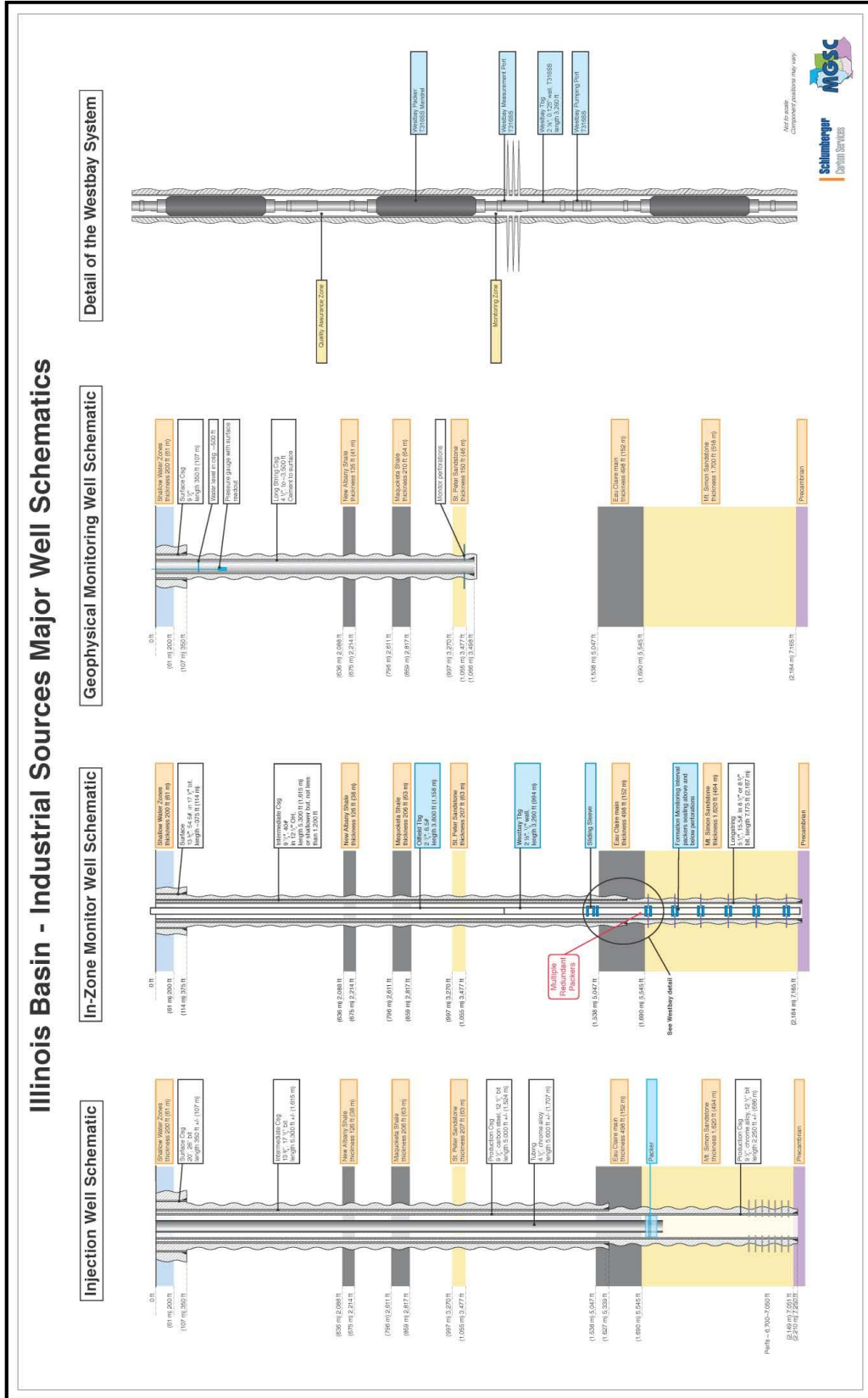

4.2 Surface Facilities

4.2.1 Injection Fluid Storage

There will be no intermediate storage of injection fluid. The CO₂ for this project is produced continuously from the ethanol production facility and will be vented to the atmosphere if the injection well is not operational.

4.2.2 Holding Tanks and Flow Lines

There will be no holding tanks for the injection fluid. The flow line from the compression and dehydration facility to the injection site is estimated to be an 8-inch diameter schedule 120 carbon steel pipe. The final pipe size, schedule, and material of construction will be determined upon completion of the final facility engineering design and reservoir modeling.

4.2.3 Process Flow Diagrams and Process Description

The front end engineering design (FEED) has been completed for the collection, compression, and dehydration, and transmission facility. The collection, compression, and dehydration facility has a design capacity of 2,000 MT per day with a maximum capacity of 2,200 MT per day. The transmission facility (8" pipeline to the injection well) has a design capacity of 3,000 MT per day with a maximum capacity of 3,300 MT per day. The process flow diagrams (PFDs) for this unit shown are shown in Figures 4-2 through 4-7. Piping & instrument diagrams (P&IDs), issued for engineering approval, are provided in Appendix C.

CO₂ is produced during ethanol fermentation and is vented from the fermentation vessels and sent to an existing wet gas scrubber (not shown in figures). In the wet gas scrubber, water is used to remove any entrained ethanol and other water soluble contaminants from this stream. Next, the water saturated CO₂ exits the top of the scrubber at 15 psia, and 100°F. This is the point at which the design basis for this facility was developed.

Illustrated in Figure 4-2, the gas leaving the scrubber passes through a separator drum (TK-501/502) to remove any condensed or entrained free water. Next the CO₂ is compressed with a centrifugal blower (BL-501/502) to 32 ps ia. Because of the compression ratio, the gas temperature increases to above 200°F. Next the hot compressed CO₂ is cooled to 95°F by passing through the compressor after cooler (HE-501). The blower after cooler separator (TK-503) removes any water that condenses during compression and cooling.

After free water removal, the gas stream is divided into four streams; each feeding a four-stage reciprocating compressors which operate in parallel. Each compressor is designed for an operational capacity of 500 MT per day with a maximum capacity of 550 MT per day. These compressors (K-600, K-700, K800, and K-900) are shown in Figure 4-3 through 4-6.

Each figure shows the 4 stages of compression and represents one machine. The compressors are six throw (6 cylinder) machines with two (2) cylinders used for the first stage of compression, two (2) cylinders for the second stage of compression, one (1) cylinder for the third stage of compression, and one (1) cylinder for the fourth stage of compression.

In the first stage (K-601/701/801/901), the CO₂ is compressed to 75 psia, with a discharge temperature of 293°F. After this stage, the gas is cooled by the interstage cooler (HE-601/701/801/901) to 95°F, and sent to an interstage separator (VS-602/702/802/902) to remove any free water condensed during compression and cooling.

From the separator, the gas flows to the second compression stage (K-602/702/802/902). In this stage the CO₂ stream is compressed to 249 psia with a discharge temperature of 313°F. Next, the compressor discharge stream is cooled to 95°F in the second interstage cooler (HE-602/702/802/902) and sent through a separator (VS-603/703/803/903) to remove any condensed water.

From the separator, the gas flows to the compressor's third stage (K-603/703/803/903), where it is compressed to 598 psia and 253°F. As with previous compression stages; the gas is cooled to 95°F in the interstage cooler (HE-603/703/803/903). At this point, 95% of the water entering the process has been removed through compression and cooling.

After the third stage of compression, the CO₂ stream contains approximately 1300 ppmwt H₂O. Because this exceeds the recommended water content for subsurface injection, the four streams are recombined to be sent to the glycol dehydration skid. This operation is represented in Figure 4-7.

The design basis for the dehydration unit is for the unit to dehydrate the CO₂ stream so that the exiting stream contains no more than 30 lbs of water per mmscf of CO₂ (265 ppmwt). Dehydration with tri-ethylene glycol (TEG) typically produces a CO₂ stream with a water content of less than 7 lbs per mmscf of CO₂ (60 ppmwt). Based on an inlet feed gas composition of 151 lb water/mmscf, the unit's water removal capacity is 173 lb/hr yielding a final CO₂ stream with water content of 11 lbs per mmscf of CO₂ (60 ppmwt).

The four streams are combined and the CO₂ stream enters the bottom of the TEG contactor (VS-751) where it is contacted with lean (water-free) glycol introduced at the top of the absorber. The glycol removes water from the CO₂ by physical absorption and the rich glycol (water saturated) exits the bottom of the column. The dry CO₂ stream leaves the top of the absorption column and passes through the contactor outlet cooler (HE-751) cooling the gas to 95°F before returning to the compression section.

Regarding the rich glycol stream, after leaving the absorber it is cross exchanged with the regenerator O/H vapor stream in the reflux condenser (HE-754). Next this stream is further heated by cross exchange with the regenerator bottoms (lean glycol) stream in the cold glycol exchanger (HE-752). Next the stream enters the glycol flash tank (TK-752) where any non condensable vapors are removed.

After leaving the flash vessel, additional heating of the rich glycol occurs by cross-exchange with the regenerator bottoms (lean glycol) in the hot glycol exchanger (HE-753) before entering the regenerator column (VS-752). The glycol regenerator consists of a column, an overhead condenser (HE-754), and a reboiler (HE-755). In this column, the glycol is thermally regenerated by hot vapor stripping the water from the liquid phase.

The hot lean glycol exits the bottom of the tower and enters the reboiler where it is heated and any remaining water is flashed into vapor (steam). The steam returns to the bottom of the tower where it acts as the stripping agent, removing water from the rich glycol. Excess lean glycol in the reboiler flows over a level weir and enters a glycol surge tank. Next the hot lean glycol gravity flows through the previously described cross exchangers (HE-752/753) where it is cooled by the rich glycol. Finally a glycol pump (PU-752) pressurizes the lean glycol allowing it to return to the contactor tower (VS-751).

After the dehydrated CO₂ gas leaves the dehydration section it is split into four streams and returned for additional compression shown in Figures 4-3 through 4-6.

In the 4th stage of compression (K-604/704/804/904) the CO₂ is compressed to 1425 psia and 272°F. After this stage the streams are cooled in the compression outlet cooler (HE-704A/704B/904A/904B) to 95°F. Next, the four CO₂ streams are combined and sent to a booster pump (PU-754), which is shown in the lower half of Figure 4-2. In this pump, the stream is compressed to 2515 psia. Finally, the compressed CO₂ flows through a transmission pipeline to the injection well and subsequently into the Mt. Simon Sandstone.

For all cooling requirements, cooling tower water was supplied at 85°F and returned at 110°F. For the fired boiler, natural gas was used as the fuel supply.

4.2.4 Filter(s)

Other than the filters on the glycol circulation system, no filters are necessary due to the lack of any significant particulate matter in the CO₂ stream.

4.2.5 Injection Pump(s)

One or more injection pumps are going to be used after main compression to increase the CO₂ stream pressure to the level needed for injection into the Mt. Simon Sandstone. The final process conditions will be supplied in the completion report after the geologic information is acquired from drilling and testing of the well.

Location

The injection pumps will be located in the CO₂ compression building.

Type

A multistage centrifugal pump(s) will be used and the final type will be determined during the detailed design stage of the project.

Name and Model Number

The name or manufacturer of the pump(s) and model number of the pump(s) will be determined during the detailed design stage of the project.

Capacity, Gallons Per Minute

The capacity of the pump(s) will be determined during the detailed design stage of the project, but the design basis is to deliver up to 3,300 MT per day of CO₂ to the wellhead.

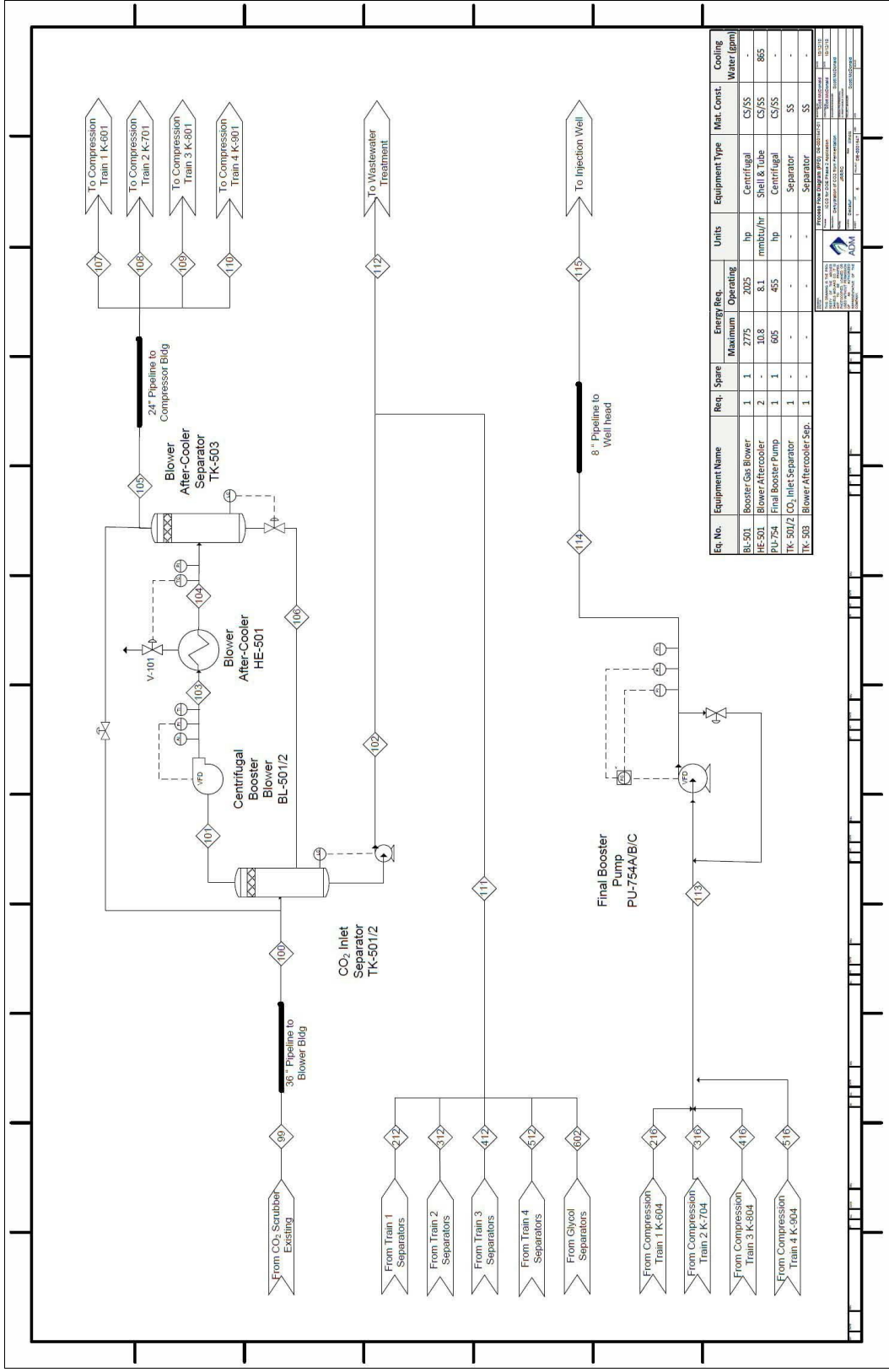

| Eq. No. | Equipment Name | Req. | Spare | Energy Req. | | Units | Equipment Type | Mat. Const. | Cooling Water (gpm) |
|----------|---------------------------------|------|-------|-------------|-----------|----------|----------------|-------------|---------------------|
| | | | | Maximum | Operating | | | | |
| BL-501 | Booster Gas Blower | 1 | 1 | 2775 | 2025 | hp | Centrifugal | CS/SS | -- |
| HE-501 | Blower After-cooler | 2 | - | 10.8 | 8.1 | mmbtu/hr | Shell & Tube | CS/SS | 865 |
| PU-754 | Final Booster Pump | 1 | 1 | 605 | 455 | hp | Centrifugal | CS/SS | -- |
| TK-501/2 | CO ₂ Inlet Separator | 1 | - | - | - | - | Separator | SS | -- |
| TK-503 | Blower After-cooler Sep. | 1 | - | - | - | - | Separator | SS | -- |

Figure 4-2: Booster Blower Prior to Compression and Final Pump to Well

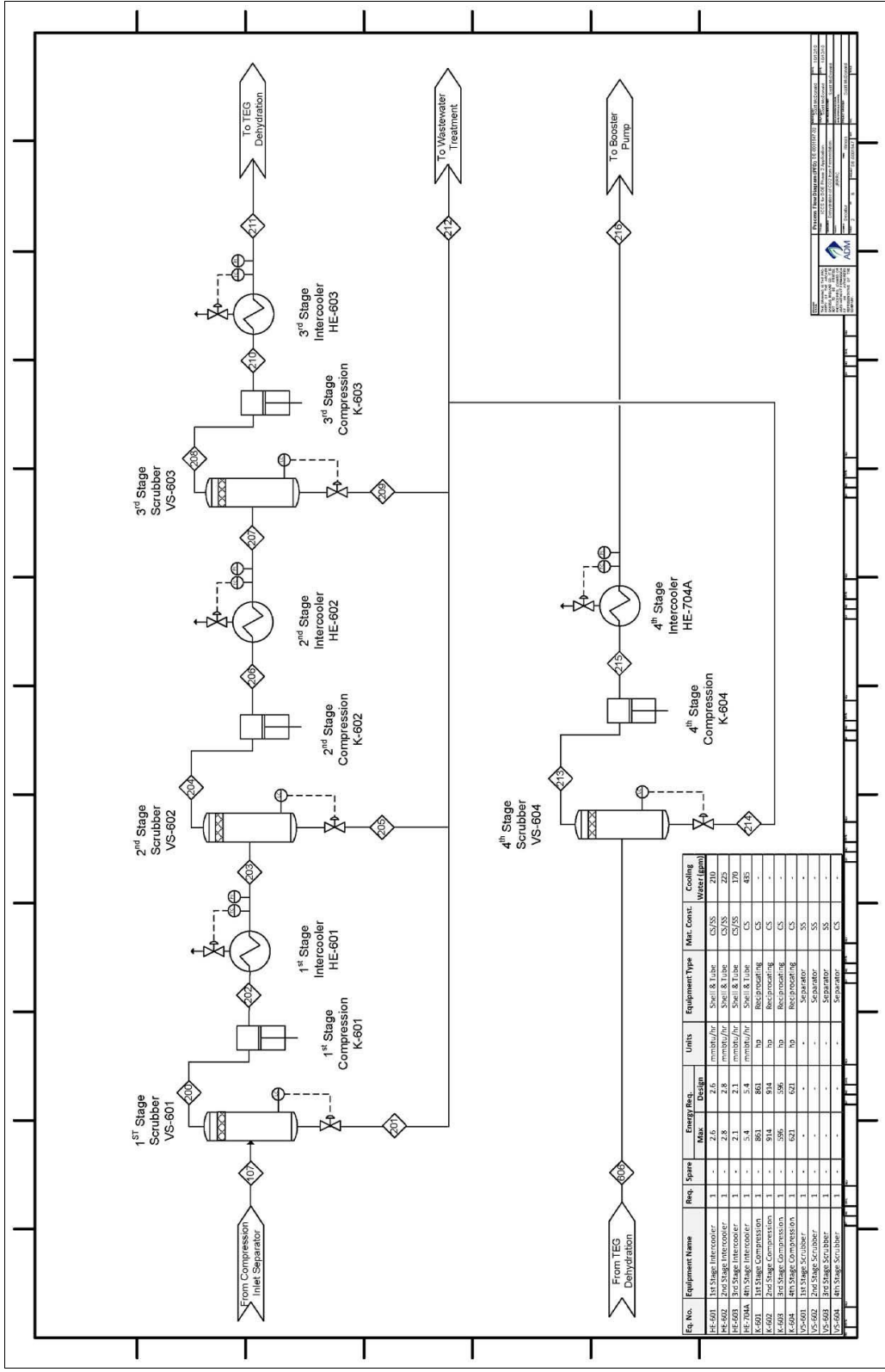

| Eq. No. | Equipment Name | Req. | Spare | Energy Req. | Max. | Design | Units | Equipment Type | Mat. Const. | Cooling Water (gpm) |
|---------|-----------------------|------|-------|-------------|------|----------|---------------|----------------|-------------|---------------------|
| HE-601 | 1st Stage Intercooler | 1 | - | 2.6 | 2.6 | mm/hr/ft | Shell & Tube | CS/SS | 210 | |
| HE-602 | 2nd Stage Intercooler | 1 | - | 2.8 | 2.8 | mm/hr/ft | Shell & Tube | CS/SS | 225 | |
| HE-603 | 3rd Stage Intercooler | 1 | - | 2.1 | 2.1 | mm/hr/ft | Shell & Tube | CS/SS | 170 | |
| K-601 | 1st Stage Compression | 1 | - | 861 | 861 | hp | Reciprocating | CS | - | |
| K-602 | 2nd Stage Compression | 1 | - | 914 | 914 | hp | Reciprocating | CS | - | |
| K-603 | 3rd Stage Compression | 1 | - | 596 | 596 | hp | Reciprocating | CS | - | |
| K-604 | 4th Stage Compression | 1 | - | 621 | 621 | hp | Reciprocating | CS | - | |
| VS-601 | 1st Stage Scrubber | 1 | - | - | - | - | Separator | SS | - | |
| VS-602 | 2nd Stage Scrubber | 1 | - | - | - | - | Separator | SS | - | |
| VS-603 | 3rd Stage Scrubber | 1 | - | - | - | - | Separator | SS | - | |
| VS-604 | 4th Stage Scrubber | 1 | - | - | - | - | Separator | CS | - | |

Figure 4-3: Train 1 of CO₂ Compression, Stages 1-4

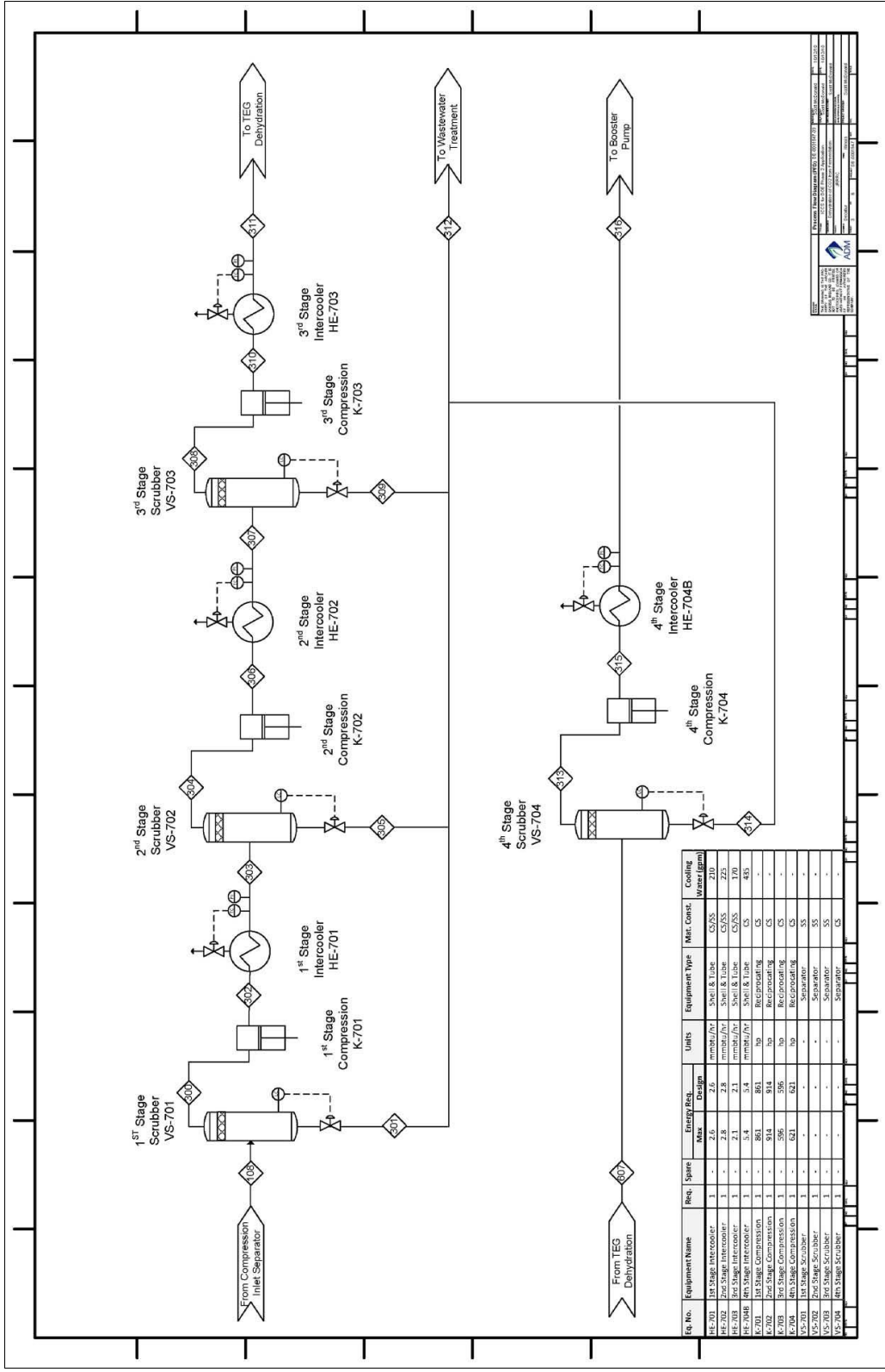

Figure 4-4: Train 2 of CO₂ Compression, Stages 1-4

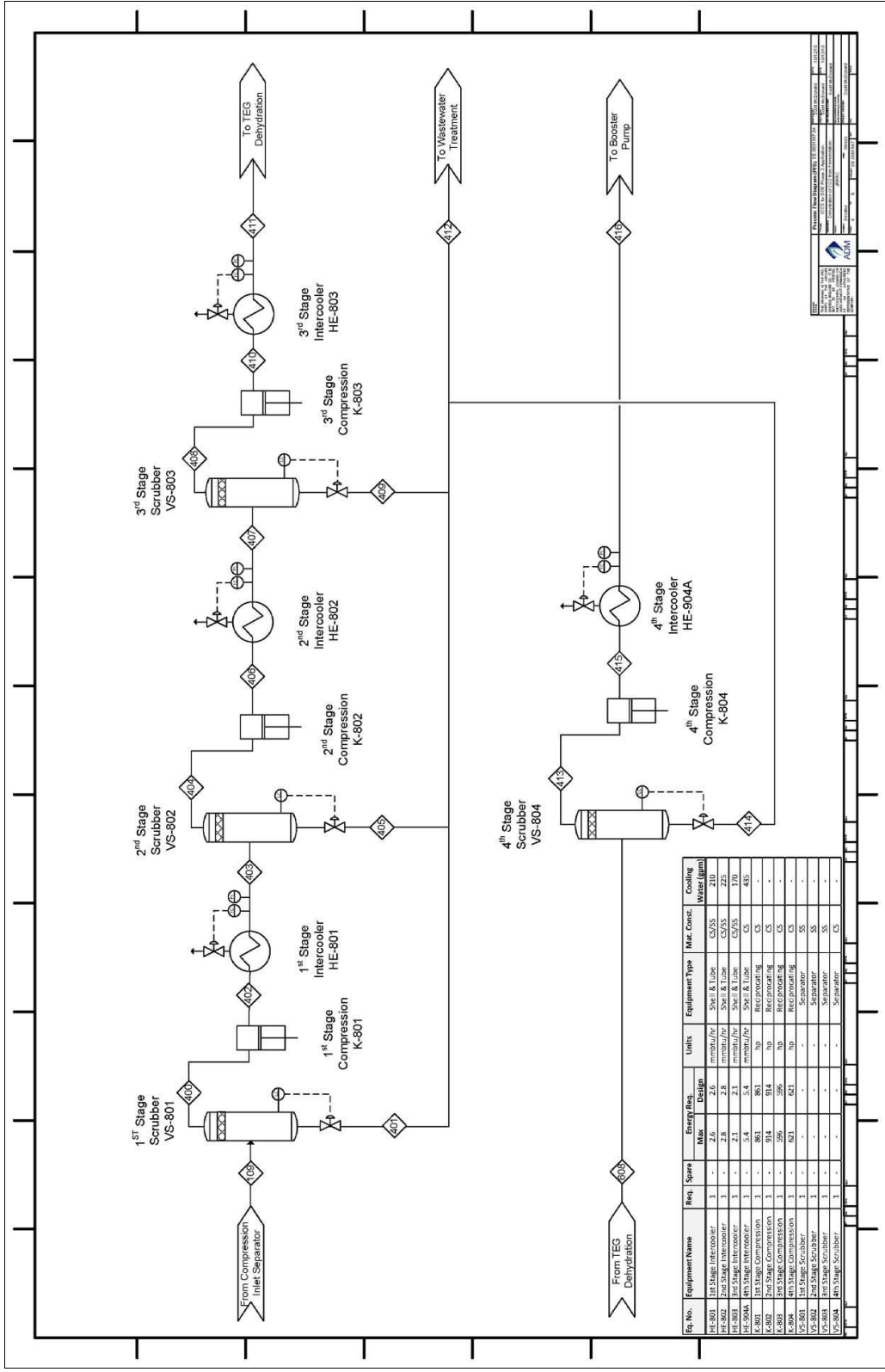
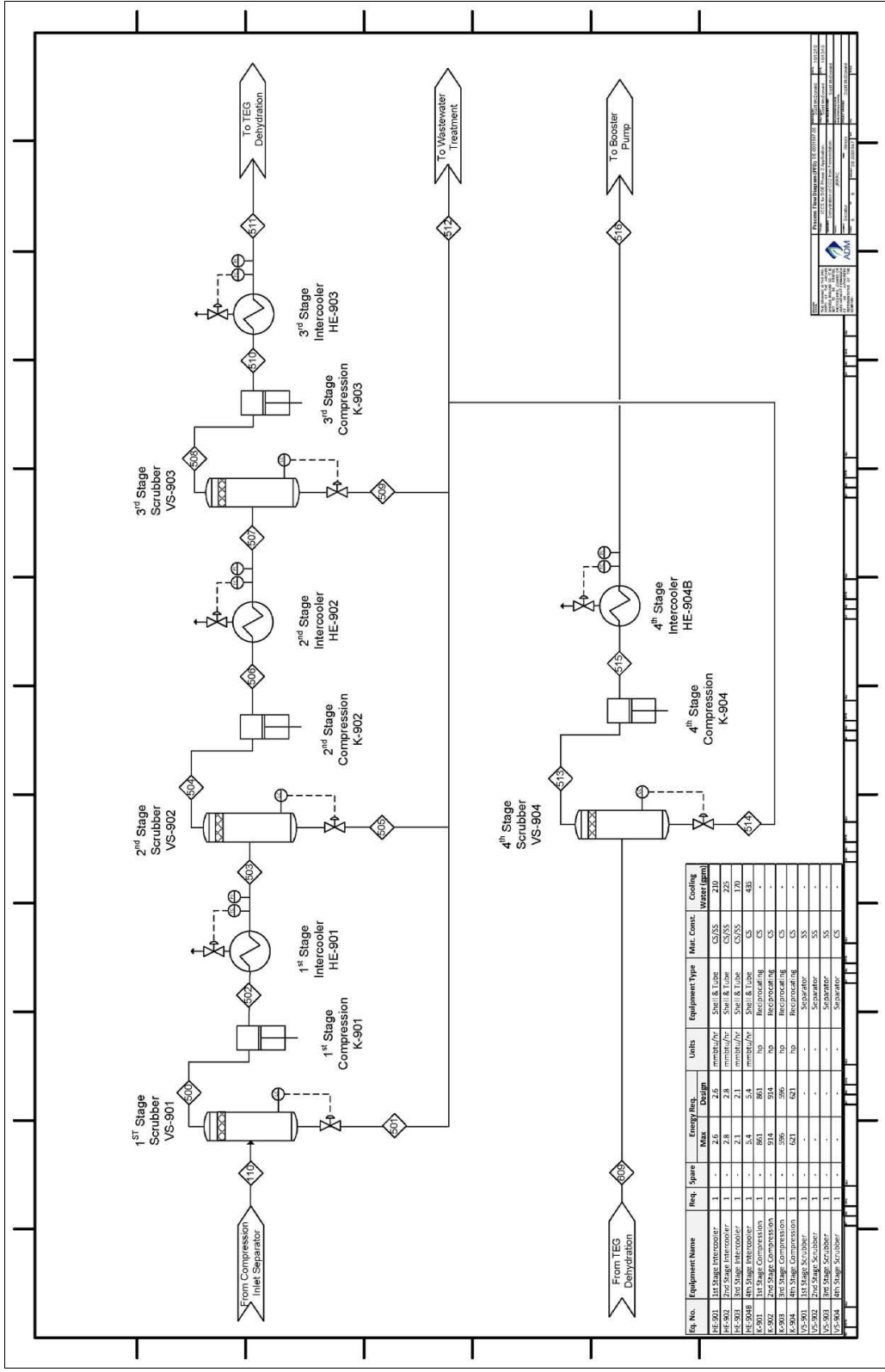

Figure 4-5: Train 3 of CO₂ Compression, Stages 1-4



| Eq. No. | Equipment Name | Req. Spares | Energy Req. Design | Units | Equipment Type | Mat. Const. | Coating |
|---------|-----------------------|-------------|--------------------|------------|----------------|-------------|---------|
| HE-901 | 1st Stage Intercooler | 1 | 2.6 | minutal/yr | Shell & Tube | CS/SS | 210 |
| HE-902 | 2nd Stage Intercooler | 1 | 2.8 | minutal/yr | Shell & Tube | CS/SS | 225 |
| HE-903 | 3rd Stage Intercooler | 1 | 2.1 | minutal/yr | Shell & Tube | CS/SS | 170 |
| HE-904B | 4th Stage Intercooler | 1 | 1.4 | minutal/yr | Shell & Tube | CS | 45 |
| K-901 | 1st Stage Compression | 1 | 86 | hp | Reciprocating | CS | - |
| K-902 | 2nd Stage Compression | 1 | 914 | hp | Reciprocating | CS | - |
| K-903 | 3rd Stage Compression | 1 | 596 | hp | Reciprocating | CS | - |
| K-904 | 4th Stage Compression | 1 | 621 | hp | Reciprocating | CS | - |
| VS-901 | 1st Stage Scrubber | 1 | - | - | Separator | SS | - |
| VS-902 | 2nd Stage Scrubber | 1 | - | - | Separator | SS | - |
| VS-903 | 3rd Stage Scrubber | 1 | - | - | Separator | SS | - |
| VS-904 | 4th Stage Scrubber | 1 | - | - | Separator | CS | - |

Figure 4-6: Train 4 of CO2 Compression, Stages 1-4

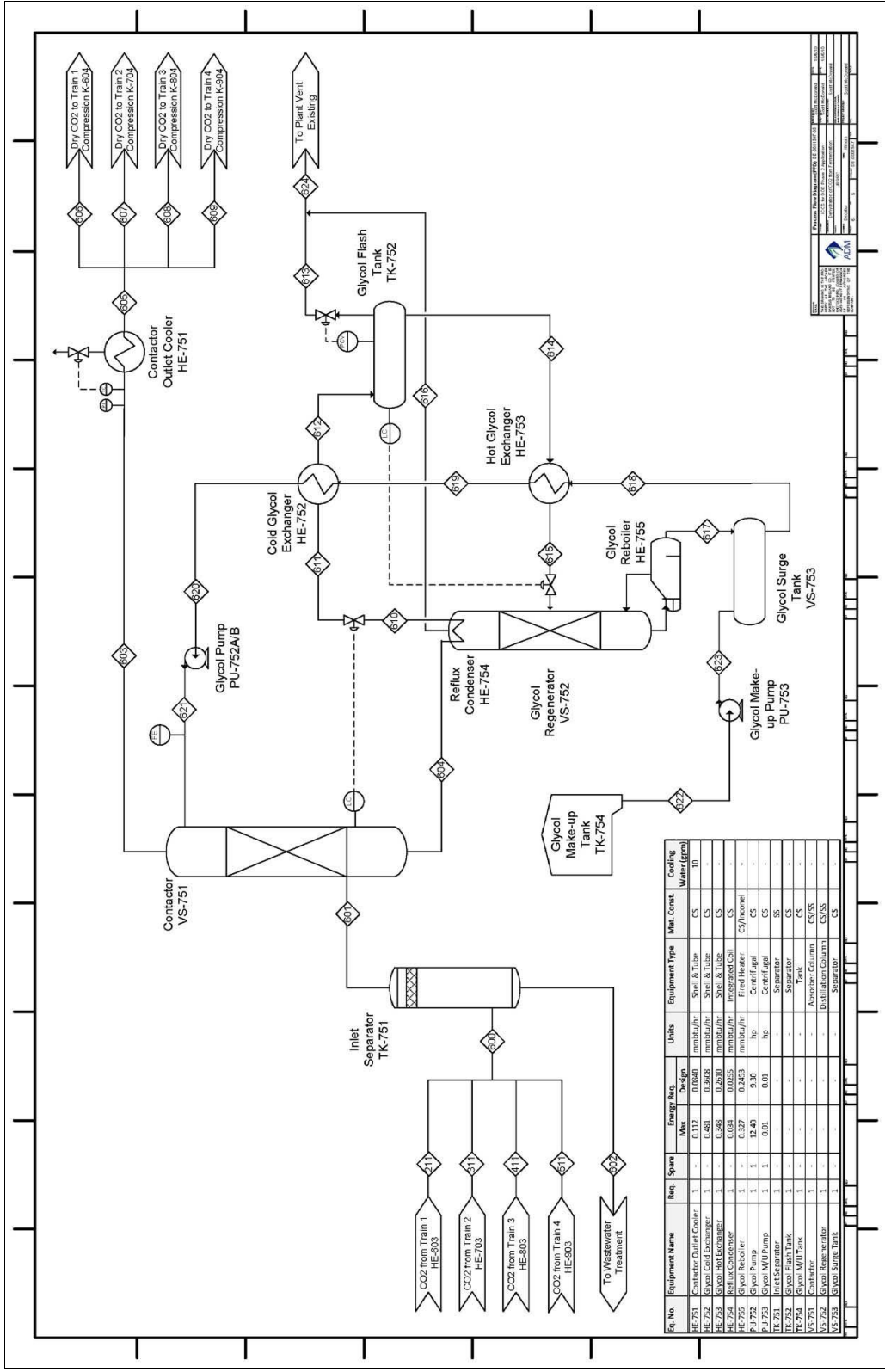

Figure 4-7: Tri-Ethylene Glycol Dehydration Process

SECTION 5 – AREA OF REVIEW

5.1 Radius of the Area of Review

A radius of approximately 3.2 kilometers (2.0 miles) was determined for the area of review (AoR).

5.2 Method of Radius Determination

The radius of the AoR is based on the *Maximum Extent of the Separate-phase Plume or Pressure-front (MESPOP)* methodology, as detailed in the relevant US EPA guidance document (USEPA, 2011). Information about the lowermost USDW and target injection zone obtained from the on-going efforts of the Illinois Basin-Decatur Project (IBDP) provided the input for the hydraulic head calculations specified in the guidance (Locke & Mehnert, 2011). Figure 5-1 illustrates the input values to these calculations and the graphical relationship between the hydraulic head in the lowermost USDW and that of the target injection interval of the lower Mt. Simon Sandstone. Results of these calculations indicate that the pressure front in the injection zone (P_{if}) is delineated by a pressure of 22.77 MPa (3302 psi), or a change in pressure of 1.27 MPa (184 psi) above the initial reservoir pressure. Based on computer modeling of the proposed 5-year injection and 50-year post-injection period, the MESPOP grows to a maximum extent of approximately 3.2 kilometers (2.0 miles) and is exclusively defined by the pressure front and not by the extent of the CO₂ plume. As a result, the CO₂ plume remains within the AoR throughout the entire simulated period. Figure 5-2 outlines the predicted extent of the pressure front within the injection interval over a topographic map of the immediate area around the project site. It should be noted that the jagged shape of the polygon outlined in blue is an artifact of the simulation grid and not physically realistic; therefore, the boundary of the AoR was extended to the green line inscribing the blue polygon, which represents a more conservative and realistic delineation. Additional details of the model input parameters and results of the simulation are discussed in Section 5.4 below.

5.3 Area of Review Map

Well logs for all wells within the AoR were obtained from four databases. Records for water wells were obtained from the Illinois State Geological Survey (ISGS) ILWATER database and the Illinois State Water Survey (ISWS) water well database. Records for oil and gas wells were obtained from the ISGS ILOIL database. In addition, logs for coal stratigraphic tests were obtained from the ISGS Coal Section. The ISWS and ISGS are the repository for all well logs acquired since 1965; however, well logs filed prior to that year were done so on a voluntary basis.

A total of 432 wells are known to be drilled within the AoR (Figure 5-2). The deepest well (excluding the IBDP injection, verification, and geophysical wells) is 762 m (2,500 ft). Fourteen wells within the AoR have been drilled to the depth range of 640 to 762 m (2,100 to 2,500 ft).

Within the AoR, the wells listed in the ISGS and ISWS databases were cross-checked to remove duplicates. The duplicates were identified by well owner, location, and/or well depth. Several wells identified only by a general location description (section, township, and range) were

assumed to be within the AoR, although it is possible these wells may actually be located beyond the AoR limits.

5.4 Description of Anticipated Injection Fluid Movement during the Life of the Project

5.4.1 Simulation Software Description and General Assumptions

Schlumberger Carbon Services (SCS) utilized ECLIPSE 300¹ reservoir simulation software with the COSTORE module to estimate CO₂ plume migration and reservoir pressure behavior below the IL-ICCS site. ECLIPSE 300 is a compositional finite-difference solver that is commonly used to simulate hydrocarbon production and has various other applications including carbon capture and storage modeling. The CO2STORE module accounts for the thermodynamic interactions between three phases: an H₂O-rich phase (i.e. ‘liquid’), a CO₂-rich phase (i.e. ‘gas’) and a solid phase, which is limited to several common salt compounds (e.g. NaCl, CaCl₂, and CaCO₃). Mutual solubilities and physical properties (e.g., density, viscosity, enthalpy, etc.) of the H₂O and CO₂ phases are calculated to match experimental results through a range of typical storage reservoir conditions, including temperatures ranging from 12-100°C and pressures up to 60 MPa. Details of the method can be found in Spycher and Pruess (Spycher & Pruess, 2005). Additional assumptions governing the phase interactions throughout the simulations are as follows:

- The salt components may exist in both the liquid and solid phases.
- The CO₂-rich phase (i.e., ‘gas’) density is obtained by an accurately tuned and modified Redlich-Kwong equation of state (Redlich & Kwong, 1949).
- The brine density is first approximated by the pure water density and then corrected for salt and CO₂ effects by Ezrokhi's method (Zaytsev & Aseyev, 1992).
- The CO₂ gas viscosity is calculated per the method described by (Vesovic, Wakeham, Olchow, Sengers, Watson, & Millat, 1990) and (Fenghour, Wakeham, & Vesovic, 1999).

Initial simulation-based estimates of fluid conditions throughout the surface pipeline and wellbore indicated that the temperature of the injectate would be comparable to the formation temperature in the injection interval; therefore, the simulations were carried out under isothermal conditions. With respect to time step selection, the software algorithm optimizes the time step duration based on specific convergence criteria designed to minimize numerical artifacts. For these simulations, time step size ranged from 8.64×10^1 to 8.64×10^5 seconds or 0.001 to 10 days.

5.4.2 Site Specific Assumptions and Methodology

The 3D geologic model developed for the injection simulations is based on the interpretation of a diverse assemblage of geophysical data acquired throughout the construction of the IBDP injection well (herein referred to as CCS #1). Structurally, the model is based on the interpretation of both 2D and 3D seismic survey data in conjunction with dipmeter log data acquired after drilling CCS #1. Petrophysical and transport properties – based on the interpreted well log data and the analysis of core samples recovered from CCS #1 – were then distributed

¹ Proprietary software of Schlumberger.

throughout each layer in the geocellular model in a homogeneous fashion. Overall model dimensions are 48.3 km by 48.3 km (30 mi. by 30 mi.) in order to minimize artificial boundary effects. Both constant-pressure and no-flow boundary conditions were evaluated initially; however, little difference was observed due to the size of the model. Consequently, subsequent simulations were carried out with no-flow boundary conditions. An irregular grid pattern was chosen for the geocellular model in order to provide enhanced detail and improved accuracy near CCS #1 and the proposed IL-ICCS injection well, CCS #2. For example, grid cells in the vicinity of the injection wells are 15.25 m by 15.25 m (50 ft by 50 ft) in the horizontal plane, while grid cells near the edges of the model domain are 3.2 km by 3.2 km (2 mi. by 2 mi.) in the horizontal plane. Figure 5-3 illustrates the overall grid dimensions and geometry of the irregular gridding pattern used throughout the model.

The geologic model encompasses approximately the lower half of the Mt. Simon Sandstone: from the top of the basal arkosic zone up to a low-porosity, low-permeability interval that is expected to be a flow-limiting barrier over the course of the simulated time frame (refer to Figures 2-7 and 2-8 for a general stratigraphic sequence). These low permeability intervals within the Mt. Simon can be correlated on geophysical well logs acquired in CCS #1 and the recently-drilled IBDP Verification Well #1, located approximately 300 meters to the north. In addition, the structural continuity of the Mt. Simon observed in the 2D and 3D seismic data acquired at both the IBDP and IL-ICCS sites, and described in Section 2.3 of this application, suggests that these geologic features are present throughout the immediate project area. Regional extent of the macro-geologic features of the Mt. Simon throughout the Illinois Basin has been demonstrated through analysis of offset well log data, as described in Section 2.4; however, the regional continuity of the micro-geologic features, such as low-permeability layers within the Mt. Simon, will be better understood with the addition of future well log, core, and 3D seismic data associated with the IL-ICCS project.

Figure 5-4 shows the porosity and permeability values in the lower half of the Mt. Simon Sandstone represented by the upscaled well log of CCS #1 and the synthetic log of CCS #2. The upscaled values are based on porosity from CCS #1 well logs and permeability transformed from porosity, which are then averaged over the thickness of each modeled layer. Layering in the model is based upon trends in the petrophysical and facies characteristics observed in both well logs and core samples. The lower half of the Mt. Simon Sandstone was subdivided into 74 layers, which range from approximately 1.2 m (4 ft) to 10 m (33 ft) in thickness. Porosity and permeability within these layers range from 8 to 26% and from 0.03 to 117 millidarcies (mD), respectively. Temperature and pressure gradients of approximately 1.8°C/100-m (1°F/100-ft) and 10.2 MPa/km (0.45 psi/ft) – based on in-situ measurements made after drilling CCS #1 – were used in the model. The formation pressure gradient in the lower half of the Mt. Simon is slightly higher than a typical fresh water gradient due to the high salinity observed in this part of the reservoir, which ranges from 179,800 ppm to 228,000 ppm total dissolved solids (TDS) based on analysis of actual formation fluid samples recovered during the drilling of CCS #1 (Frommelt, 2010).

Based on the range of porosity and permeability values observed in log data and core samples obtained from CCS #1, a suite of proprietary relative permeability and capillary pressure curves were developed in collaboration with the CO₂ Sequestration Team at the Schlumberger-Doll Research Center in Cambridge, MA, USA. Figure 5-5 depicts the relative permeability curves

which govern the multi-phase flow behavior of the CO₂-brine system during both drainage (i.e., displacement of wetting phase) and imbibition (i.e., re-entry of wetting phase). Figures 5-6 and 5-7 depict the capillary pressure behavior of the CO₂-brine system during drainage and imbibition, respectively, for four different classifications of lithology defined by intrinsic permeability. For example, Pc(1) represents the capillary pressure behavior for lithologies with intrinsic permeabilities less than 1 mD; Pc(2) for permeabilities between 1 mD and 10 mD; Pc(3) for permeabilities between 10 mD and 100 mD; and Pc(4) for permeabilities greater than 100 mD.

Another governing parameter used in the reservoir simulation was the fracture pressure gradient of the lower Mt. Simon Sandstone. The fracture pressure gradient in the lower Mt. Simon was demonstrated via step rate test in CCS #1 to be 16.2 MPa/km (0.715 psi/ft) (refer to Section 2.4.3.3 for description). For the purposes of the reservoir simulations, the bottomhole injection pressure in CCS #1 was allowed to operate up to 80% of this gradient, whereas the bottomhole injection pressure in CCS #2 was allowed to operate up to 90% on account of the higher injection rate.

During the course of the simulation, CO₂ was injected into CCS #1 for 1 year at 1,000 MT/day, followed by 2 years of dual injection – 1,000 MT/day into CCS #1 and 2,000 MT/day into CCS #2 – followed by 3 years of injection into CCS #2 at 3,000 MT/day with CCS #1 shut-in. Following a total of five years of injection into CCS #2, 50 years of shut-in were simulated in order to understand the long-term behavior of the CO₂ plume and the reservoir pressure within the injection zone. The injection of CO₂ was limited to the lower part of the Mt. Simon – just above the basal arkosic zone – since it is the most porous and permeable interval in the injection zone. In the case of CCS #1, the existing (‘as-completed’) perforated interval of 16.8 m (55 ft) was assumed for the simulations (Frommelt, 2010), whereas in the case of CCS #2, a perforated interval of 100 m (330 ft) was required to meet the maximum proposed injection rates.

5.4.3 Simulation Results

Based on simulation results, the maximum diameter of the CO₂ plume resulting from injection into CCS #2 is estimated to be 1800 m (5,900 ft) once injection ceases and is expected to interact with the CCS #1 plume. Since the injection interval is near the base of the Mt. Simon, CO₂ flows upward from the injection interval due to its buoyant rise through the denser native brine. As it rises, CO₂ saturation increases below the lower permeability intervals within the Mt. Simon. This, in turn, causes the CO₂ plume to gradually pool and spread laterally beneath these lower permeability strata which results in slow growth of the plume footprint to a maximum diameter of approximately 2235 m (7,333 ft) at the end of the 50-year post-injection period. Not coincidentally, it is these lower permeability strata within the Mt. Simon that also limit the ultimate vertical migration through the injection zone, such that after five years of continuous injection through the IL-ICCS well and 50 years of shut-in, the CO₂ remains well within the lower half of the Mt. Simon. The development of and interaction between the CO₂ plumes resulting from injection into CCS #1 and CCS #2 is illustrated in cross-sectional view at various times in Figure 5-8. Figures 5-9 through 5-21 depict map-view representations of the aggregate plume area at various times superimposed on a satellite image of the project area. Each figure is accompanied by an estimate of the aggregate area (in square kilometers) of the two plumes along with an equivalent circular radius. Also depicted in Figures 5-9 through 5-21 is the development

of the pressure front ($P_{i,f}$) boundary through simulated time. Each figure is accompanied by an estimate of the area encompassed by the pressure front (in square kilometers) along with an equivalent circular radius. Figures 5-22 and 5-23 summarize this same information in graphical form for both the pressure front and CO₂ plume throughout the simulated time period.

It is noteworthy that the pressure front boundary continues to grow throughout the injection period (through Year 6) to a maximum equivalent radius of 3.2 km, after which point the reservoir pressure quickly decays. By Year 8, the pressure throughout the reservoir has dropped below the threshold pressure defined in Section 5.2 (i.e., $P_{i,f} = 22.77$ MPa). One implication of this prediction is that after Year 7, the AoR is likely to be delineated exclusively by the footprint of the aggregate CO₂ plume rather than by pressure, which dramatically reduces the size of the AoR during the post-injection period. Another obvious feature in the pressure boundary is the jagged shape of the footprint. As described in Section 5.2, the jagged shape of the footprint is an artifact of the geocellular grid, which is comprised of small cells near the injection wells and progressively large cells beyond the immediate injection area. This transition is most notable between Figure 5-11 and Figure 5-12 as the pressure front boundary begins to grow larger than the area of fine grid cells and into the area of coarser grid cells. While this transition does impart an unnatural appearance to the pressure boundary, there is little impact on the accuracy of the resulting pressure estimate since these are areas of relatively low flux and very little change in fluid saturation.

Several additional interesting features can be identified in the sequence of images presented in Figure 5-8 through Figure 5-21. First, the shape of the CO₂ plume created by injection through CCS #1 is initially symmetrical during the first year of simulated injection due to the homogeneous nature of the geologic model. The symmetry of the plume is altered, however, once injection begins in CCS #2 and this effect becomes more dramatic throughout simulated time. This highlights the fact that, as a result of the pressure interference, the concurrent injections will influence each other even before the CO₂ plumes interact.

A second notable observation is that the brine displaced ahead of the advancing CO₂ plume created by the injection into CCS #2 not only distorts the shape of the plume around CCS #1, but also sweeps away mobile CO₂ from the nearest edges of the plume, leaving behind a 'shadow' of residually-trapped CO₂. This affect is most apparent when comparing the Year 3 and Year 7 cross-sectional views in Figure 5-8. The CO₂ that is residually trapped as a result of the encroaching brine is depicted in light-blue, or the 0.2 – 0.25 range in the CO₂ saturation color bar. This residually-trapped CO₂ is immobilized by capillary forces and can be seen to persist through the remaining cross-sectional images in Figure 5-8, suggesting long-term storage in the lower Mt. Simon.

A third notable observation is the difference in the size of the plumes. While dramatic, this size difference is easily explained by the difference in injection rates of CO₂ into the two wells: 1000 MT/day for three years into CCS #1 versus 2000 MT/day for two years and 3000 MT/day for three years into CCS #2. Furthermore, the perforated interval simulated in the two wells is dramatically different: 16.8 m in CCS #1 versus 100 m in CCS #2. This difference alone accounts for the majority of the difference in plume height observed in Figure 5-8.

Finally, a fourth notable observation is the continued vertical growth of the plumes throughout the simulated 50-year post-injection period. Although the CO₂ plumes do continue to grow vertically under buoyant forces after injection ceases, the vertical extent is ultimately limited by lower permeability intervals within the Mt. Simon. The cross-sectional profiles at various times depicted in Figure 5-8 illustrate how the CO₂ saturation increases below these lower permeability strata, which results in the lateral spreading of the CO₂ plume. While this does increase the footprint area of the plume, it retains the CO₂ well within the lower half of the Mt. Simon. Moreover, as can be seen in the Year 56 profile of Figure 5-8, the plume has not even reached the upper model boundary, which in this case, only extends to the low-porosity, low-permeability interval mid-way through the Mt. Simon Sandstone.

Geochemical Modeling. No compatibility problems are anticipated in the injection zone. Geochemical modeling was used to predict the effects of injecting supercritical CO₂ into a model Mt. Simon Sandstone (Berger, Mehnert, & Roy, 2009). Based on chemical and mineralogical data from the Manlove Gas Storage Field in Illinois, the geochemical modeling software package, Geochemist's Workbench (Bethke, 2006), was used to simulate geochemical reactions. As expected, the injected CO₂ decreased the pH of the formation brine to about pH 4.5. As the reaction was allowed to progress, the pH of the formation brine increased to pH 5.4.

In the geochemical simulations mentioned above, Berger et al (2009), it was predicted that illite and glauconite dissolved initially. As the reaction was allowed to proceed, kaolinite and smectite were predicted to precipitate. It was predicted that the volume of pore space would not be significantly altered (Berger, Mehnert, & Roy, 2009). Therefore, no compatibility problems, such as a major reduction in injection-formation permeability resulting from chemical precipitates, are expected.

Geochemist's Workbench predicts the geochemical reaction of CO₂ with the Eau Claire Formation. Modeling results indicated that illite and smectite would initially dissolve, but that the dissolved CO₂ could be precipitated as carbonates (Berger, Mehnert, & Roy, 2009). This dissolution and precipitation process is not expected to affect the caprock integrity.

5.5 Wells within the Area of Review

5.5.1 Tabulation of Well Data Within the AoR

A total of 432 wells are located within the area of review. Water wells (371 of 432 wells) are the most common well type. The domestic water wells have depths of less than 60 m (200 ft). Other wells include stratigraphic test holes, other water wells, and oil and gas wells. Appendix D provides a full size map of the wells within the AoR and a listing of these wells with their API number, well owner, well location, well type, and well depth identified (if known). All wells within the 4 townships surrounding the proposed injection well site were also identified (total of 3,746 wells). Information regarding these wells is provided as a supplement to this permit application (available in electronic format).

Ten oil and gas wells are located within approximately 2.4 km (1.5 miles) from the proposed injection well location. The closest well is located in the northeast quarter of Section 5, T16N, R3E. This well (API number 121150061800) was drilled as a gas well in 1933 and was 27 m (88

ft) deep. There is no record of this well being plugged. This well was likely collecting naturally occurring methane from the Quaternary sediments. The other 9 wells are located in Section 5, T16N, R3E or Section 28 and Section 29, T17N, R3E. The deepest of these oil wells is API number 121150054700, located in the northwest quarter of Section 28. This well was drilled into the Lower Devonian and was 714 m (2,344 ft) deep.

The water table is expected to reflect the elevation of the land surface. In general, shallow groundwater is expected to flow toward the east and southeast toward the Sangamon River and Lake Decatur.

5.5.2 Number of Wells within the AoR Penetrating the Uppermost Injection Zone

With the exception of the IBDP injection and verification wells, there are no known wells within the area of review that penetrate deeper than 762 m (2,500 ft). The depth to the top of the injection zone (Mt. Simon Sandstone) is 1690 m (5,545 ft). Therefore, there are only two known wells that penetrate the uppermost injection zone.

Properly Plugged and Abandoned: No wells deeper than 762 m (2,500 ft) are known to have been plugged and abandoned within the AoR.

Temporarily Abandoned: No wells deeper than 762 m (2,500 ft) are known to have been temporarily abandoned within the AoR.

Operating: Two wells penetrating the uppermost injection zone (IBDP injection and verification wells, CCS #1 and Verification Well #1) are known to be in use within the AoR. As of May 2011, the IBDP injection well has not begun injection.

No plugging affidavits are provided, as the IBDP wells are currently in use.

5.5.3 Proposed Corrective Action for Unplugged Wells Penetrating the Injection Zone

No wells have been found that are believed to require corrective action. The AoR will be re-evaluated periodically (see Section 5.6 below) to verify whether corrective actions may be necessary in the future.

5.6 Area of Review Re-Evaluation & Corrective Action Plan

This section is intended to satisfy the requirements of 40 CFR 146.84.

AoR Re-Evaluation.

In accordance with Federal regulations for Class VI (geologic sequestration) injection wells, the AoR will be re-evaluated on a 5-year basis following issuance of the UIC permit. During each re-evaluation, the following will be performed:

- New wells within the AoR that exceed a depth of 305 m (1,000 ft) will be identified;
- Wells exceeding a depth of 305 m (1,000 ft) within the AoR that have been plugged & abandoned will be identified;

- Monitoring and operational data from the injection well (CCS#2), other surrounding wells, and other sources will be analyzed to assess whether the predicted CO₂ plume migration is consistent with actual data. An AOR Corrective Plan flowchart is shown in Figure 5-24. A table which summarizes key monitoring and operational data is shown in Table 5-1.

If data are inconsistent with model predictions, ADM will assess whether the inconsistency is related to unanticipated conditions within the Mt. Simon Sandstone, or if the inconsistency suggests that location(s) within the AoR may be subject to CO₂ leakage.

Monitoring and operational data will be analyzed on a frequent (likely annual) basis by ADM and/or its partners in the IL-ICCS project. If data suggest that a significant change in the size or shape of the actual CO₂ plume as compared to the predicted CO₂ plume is occurring, or if the actual reservoir pressures are significantly different than predicted pressures, ADM will initiate an AoR re-evaluation, prior to the 5-year re-evaluation period.

Re-Evaluation Report.

Following each AoR re-evaluation, a report will be prepared documenting the AoR re-evaluation process, data evaluated, any corrective actions determined necessary, and the schedule for any corrective actions to be performed. The report will be submitted to the regulatory agency for approval within a timeframe specified by permit.

If no changes result from the AoR re-evaluation, the report will include the data and results demonstrating that no changes are necessary. Each re-evaluation report shall be retained by ADM for a period of 10 years.

Corrective Action.

If corrective actions are warranted based on the AoR re-evaluation, ADM will take the following actions:

- Identify all wells within the AoR that may require corrective action (e.g., plugging),
- Identify the appropriate corrective action for the well(s),
- Prioritize corrective actions to be performed, and
- Conduct corrective actions in an expedient manner to minimize risk of CO₂ leakage to a USDW.

Based on the information obtained for the ICCS project permit application, no corrective actions are believed to be necessary within the area of review.

State, Tribe, and Territory Contact Information.

In accordance with 40 C FR 146.82(a)(20), the State of Illinois is the only State, Tribe, or Territory identified to be within the area of review. Contact information for the State of Illinois will be directed through:

Illinois Environmental Protection Agency (IEPA)
Mr. Kevin Lesko, UIC Permit Engineer, Bureau of Land
1021 N. Grand Avenue East
Springfield, IL 62794-9276
Phone: (217) 524-3271
Kevin.Lesko@illinois.gov

5.7 References

- Berger, P. M., Mehnert, E., & Roy, W. R. (2009). Geochemical Modeling of Carbon Sequestration in the Mt. Simon Sandstone. *Abstracts with Programs* , 41 (4), 4.
- Bethke, C. M. (2006). *The Geochemist's Workbench (Release 6.0) Reference Manual*. Golden, CO: Rockware, Inc.
- Fenghour, A., Wakeham, W. A., & Vesovic, V. (1999). The Viscosity of Carbon Dioxide. *J. Phys. Chem. Ref. Data* , 27 (1).
- Frommelt, D. (2010). *Letter to the Illinois Environmental Protection Agency, Subject: CCS Well #1 Completion Report, – UIC Permit UIC-012-ADM*. Archer Daniels Midland Company.
- Locke, R. A., & Mehnert, E. (2011). *Quarterly Groundwater Report for Illinois EPA Underground Injection Control Permit Number UIC-012-ADM (2011 Q1)*. University of Illinois, Illinois State Geological Survey.
- Redlich, Otto, & Kwong, J. N. S. (1949). On the Thermodynamics of Solutions. V. An Equation of State. Fugacities of Gaseous Solutions. *Chemical Reviews*, 44 (1): 233.
- Spycher, N., & Pruess, K. (2005). CO₂-H₂O mixtures in the geological sequestration of CO₂. II. Partitioning in chloride brines at 12-100C and up to 600 bar. *Geochimica et Cosmochimica Acta* , 69 (13), 3309-3320.
- USEPA. (2011). *Geologic Sequestration of Carbon Dioxide: Underground Injection Control (UIC) Class VI Well Area of Review Evaluation and Corrective Action Guidance for Owners and Operators*. Office of Water, EPA 816-D-10-007.
- Vesovic, V., Wakeham, W. A., Olchoway, G. A., Sengers, J. V., Watson, J. T., & Millat, J. (1990). The Transport Properties of Carbon Dioxide. *J. Phys. Chem. Ref. Data* , 19 (3).
- Zaytsev, I. D., & Aseyev, G. G. (1992). *Properties of Aqueous Solutions of Electrolytes*. Boca Raton, FL: CRC Press.

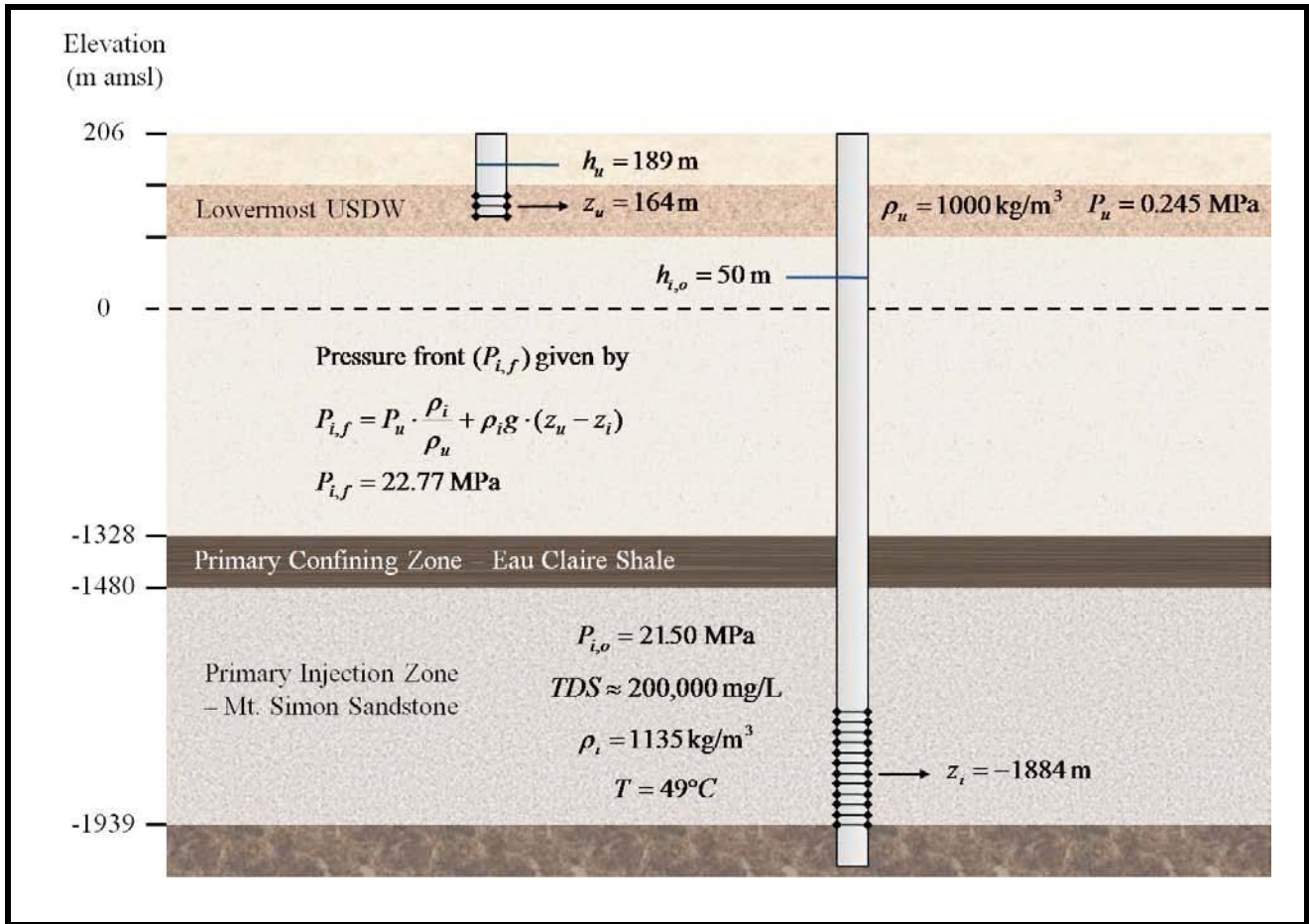

Figure 5-1: Illustration of pressure front delineation calculation based on data from IL-ICCS site.

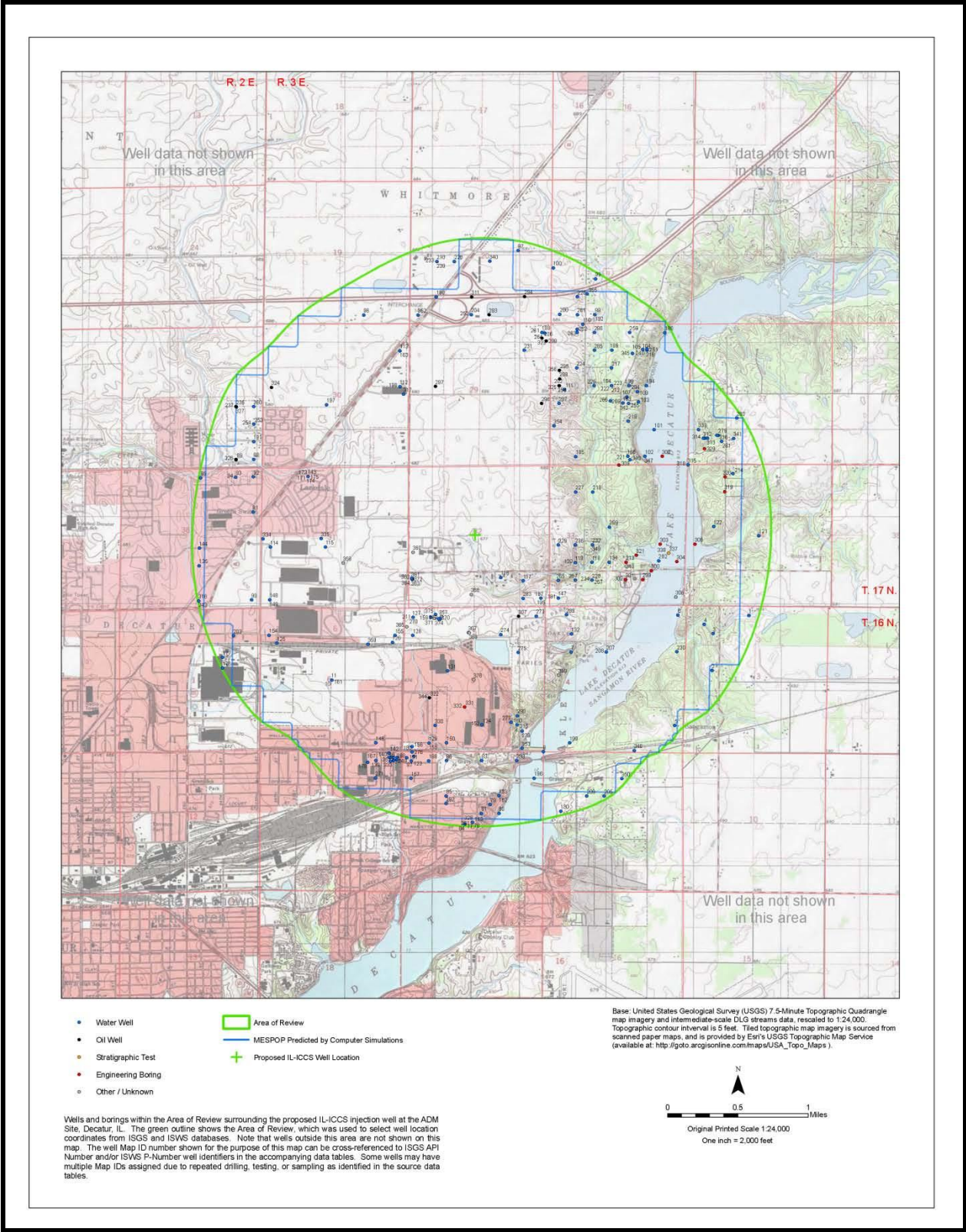

Figure 5-2: Well Penetrations within approximately 3.2 km (2.0 mile) radius of site. Source: ISWS and ISGS databases, data current as of May 10, 2011.

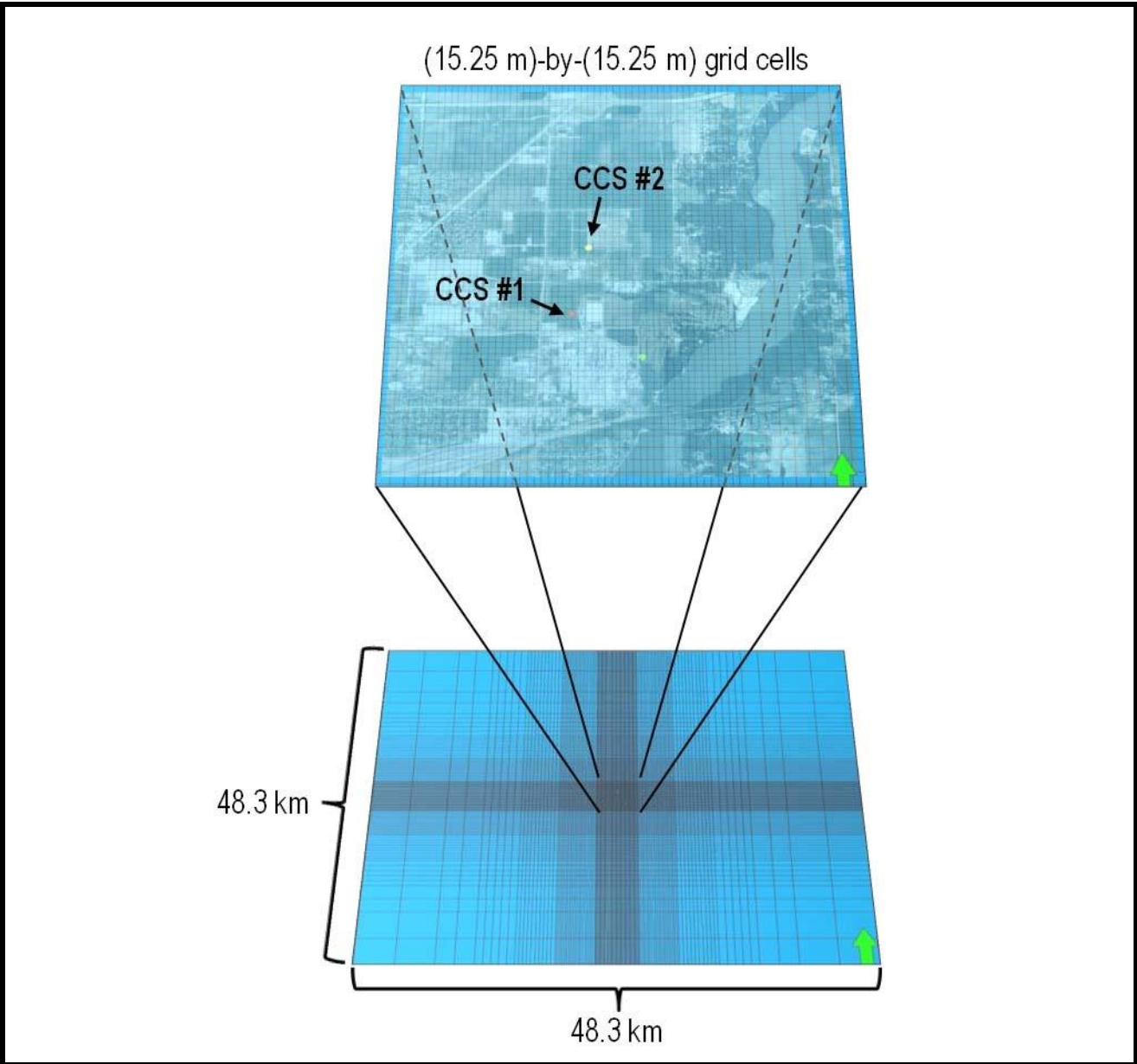

Figure 5-3: Depiction of irregular gridding pattern and dimensions of geocellular model used in reservoir simulations.

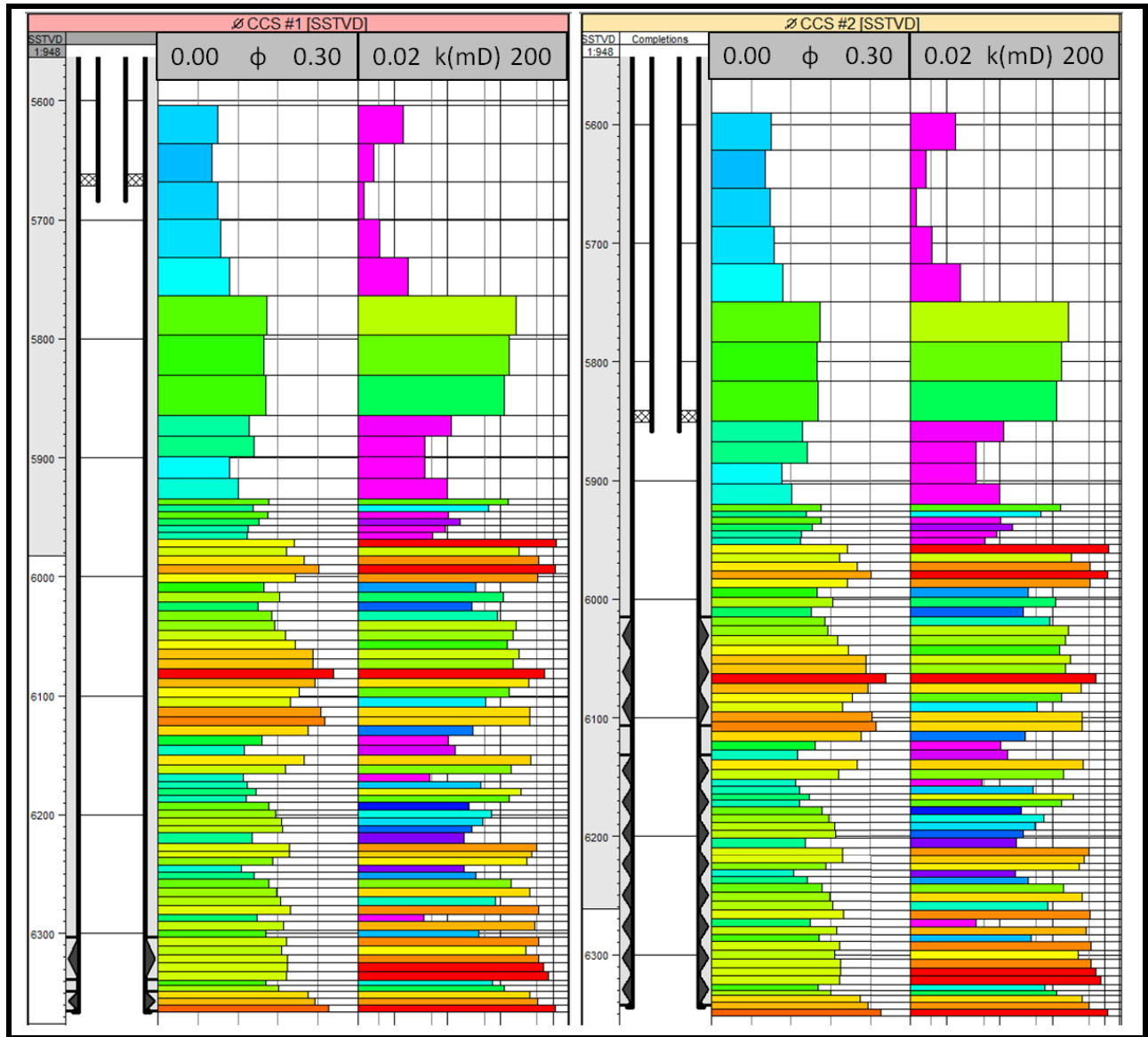

Figure 5-4: Upscaled well logs with respect to sub-surface true vertical depth (SSTVD) in feet of porosity and permeability (mD) from CCS #1 and proposed IL-ICCS injection well.

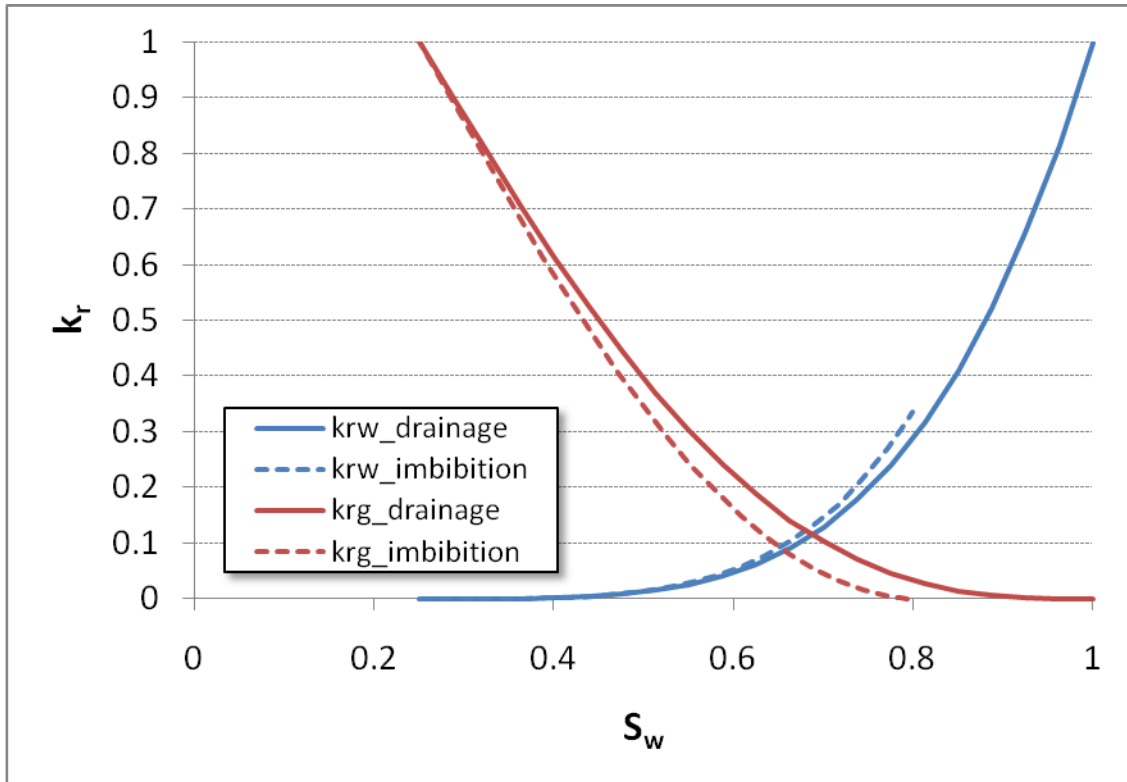

Figure 5-5: Relative permeability curves of the CO₂-brine system during drainage and imbibition.

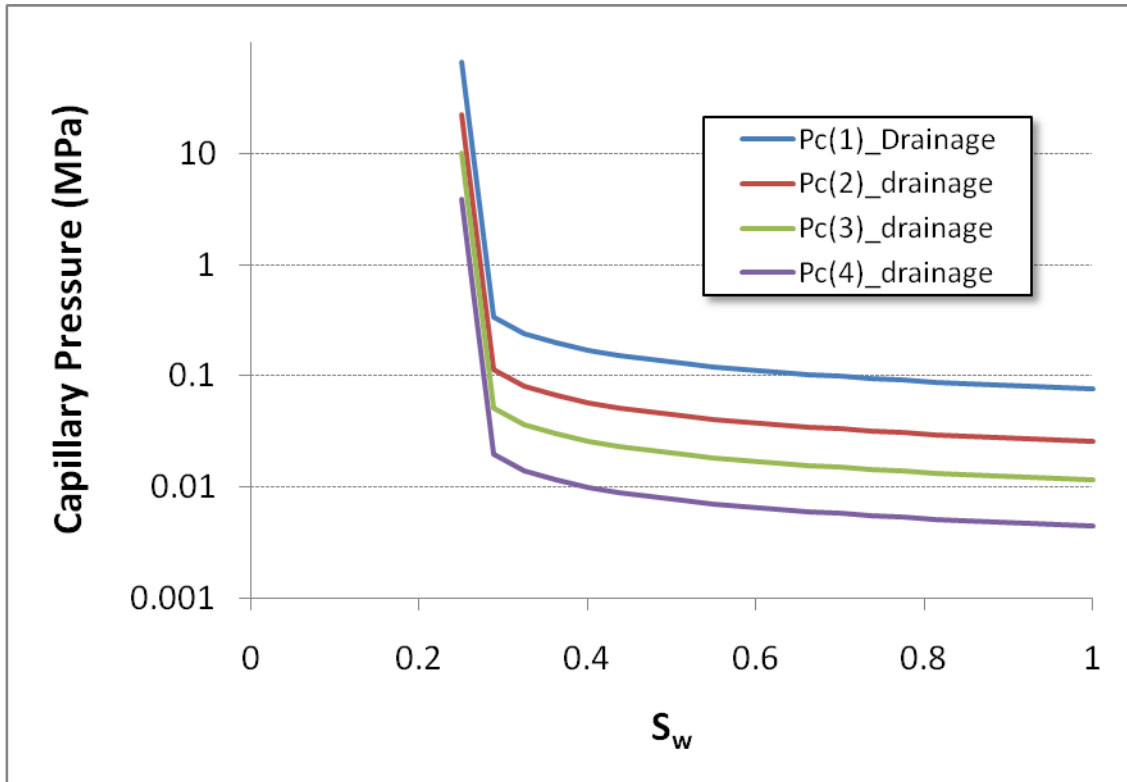

Figure 5-6: Capillary pressure behavior of the CO₂-brine system during drainage.

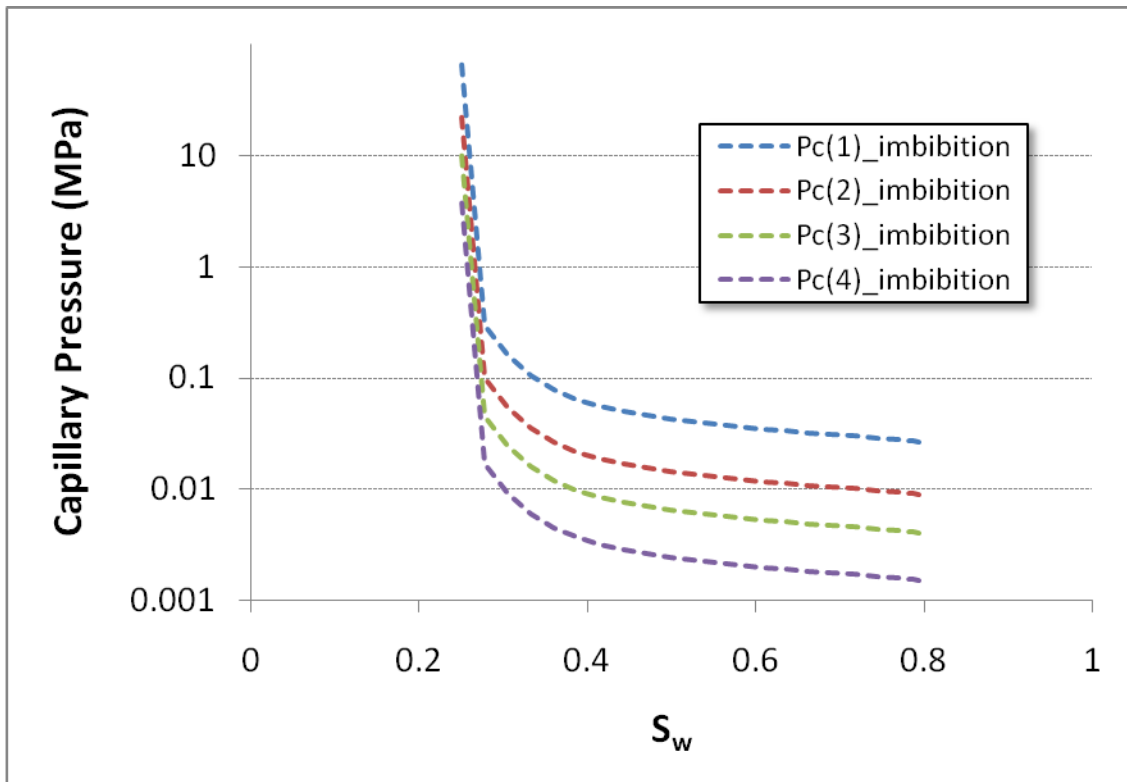

Figure 5-7: Capillary pressure behavior of the CO₂-brine system during imbibition.

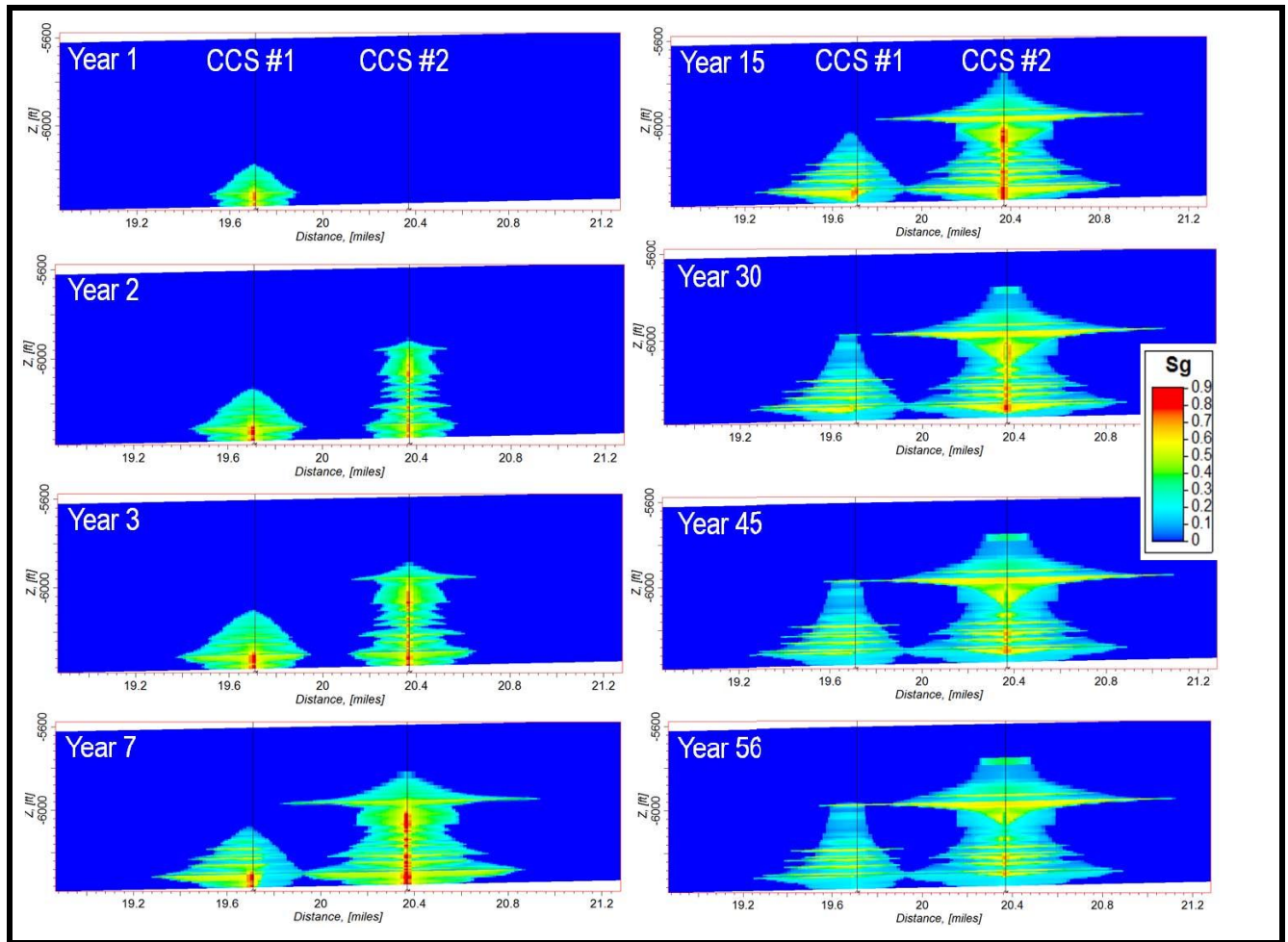

Figure 5-8: Cross-sectional views of CO₂ plumes (represented by gas saturation, S_g, ranging from 0 to 1) at various time steps during simulation.

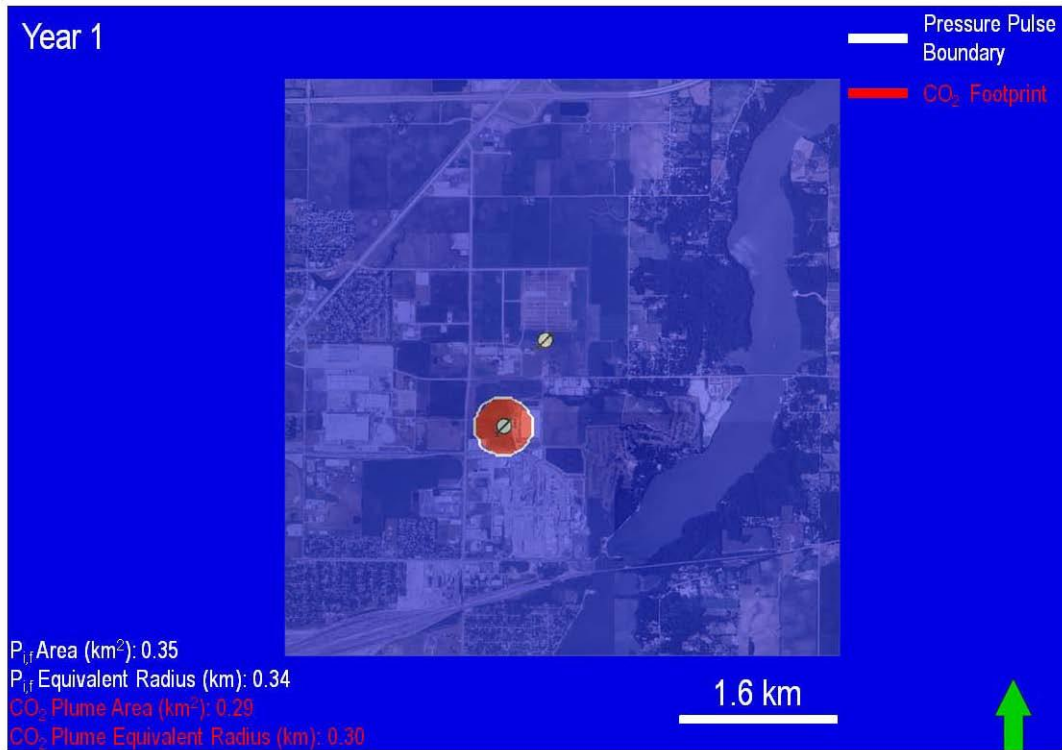

Figure 5-9: Map-view of pressure front ($P_{i,f}$) and CO₂ plume footprints after simulated Year 1.

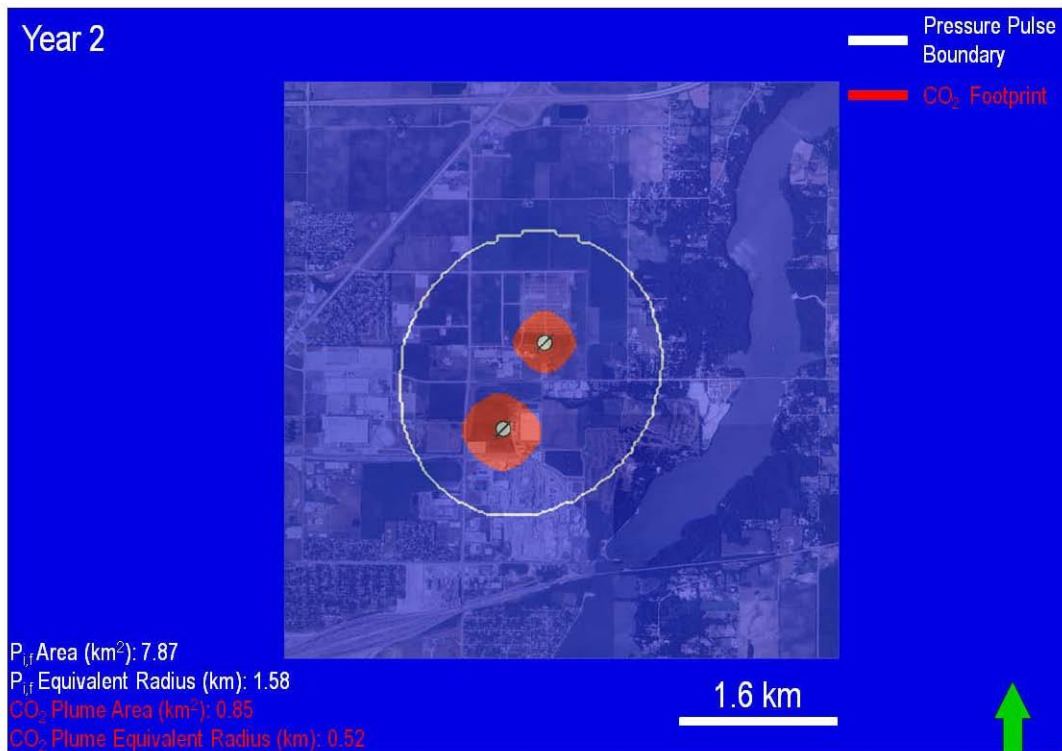

Figure 5-10: Map-view of pressure front ($P_{i,f}$) and CO₂ plume footprints after simulated Year 2.

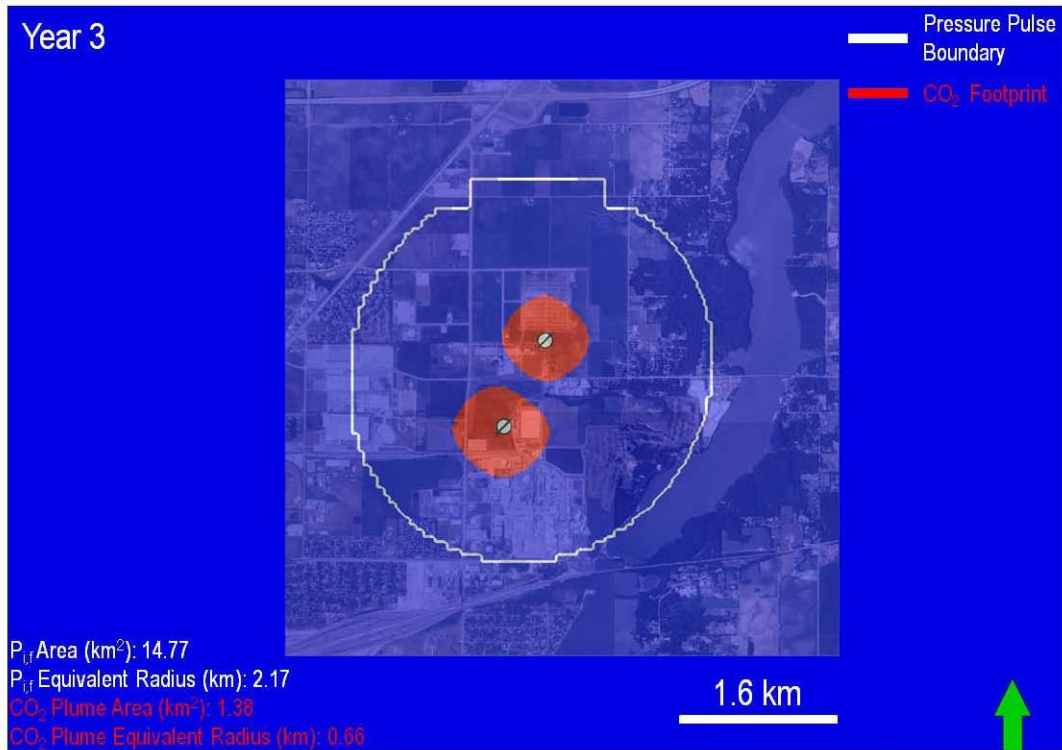

Figure 5-11: Map-view of pressure front ($P_{i,f}$) and CO₂ plume footprints after simulated Year 3.

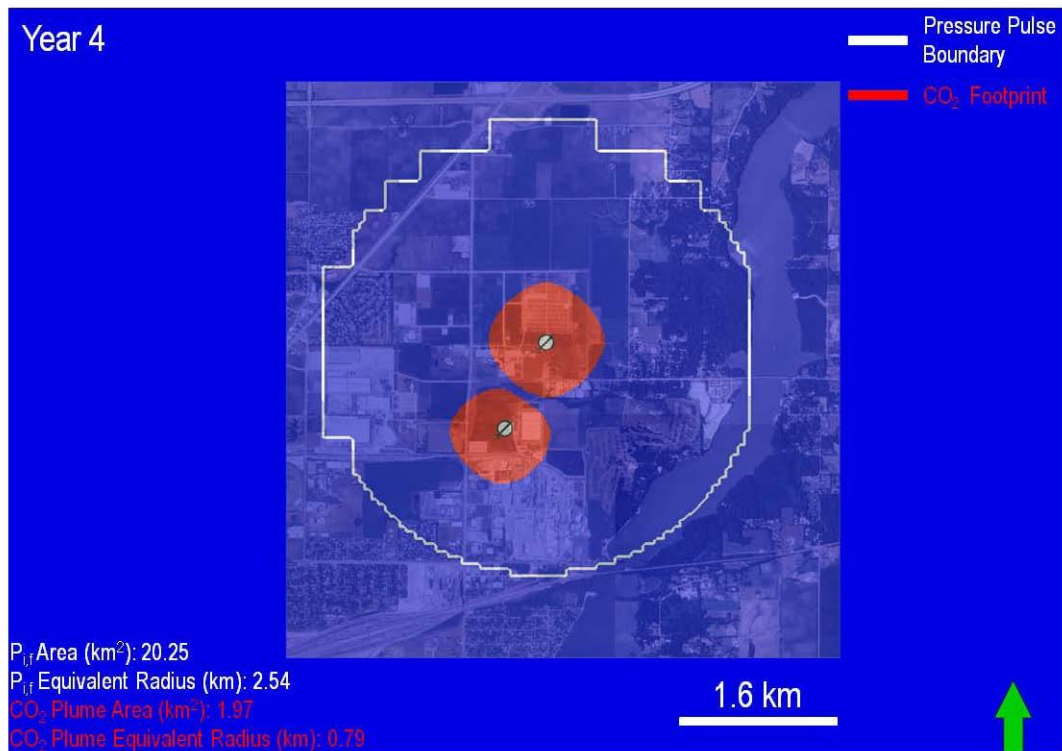

Figure 5-12: Map-view of pressure front ($P_{i,f}$) and CO₂ plume footprints after simulated Year 4.

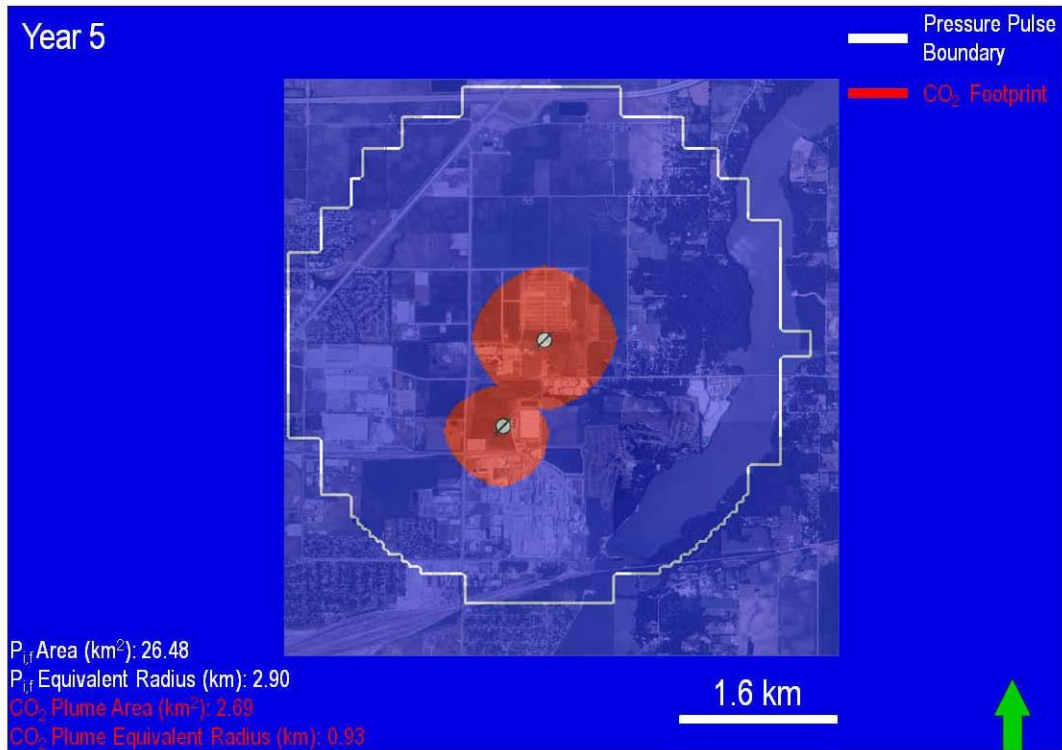

Figure 5-13: Map-view of pressure front ($P_{i,f}$) and CO₂ plume footprints after simulated Year 5.

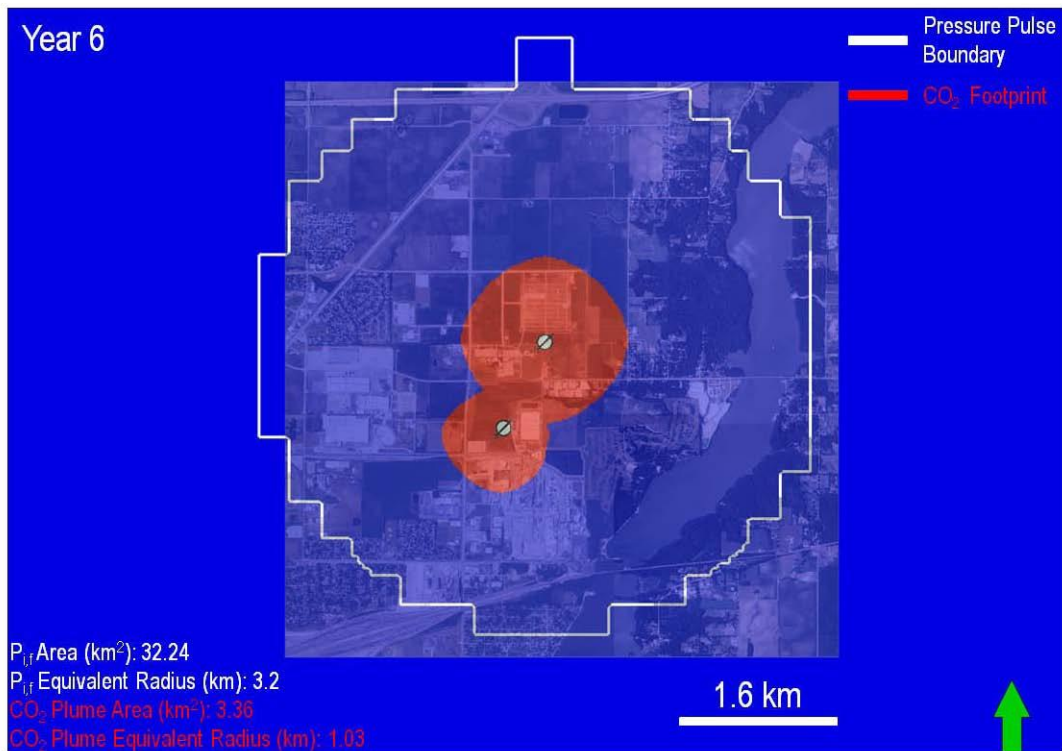

Figure 5-14: Map-view of pressure front ($P_{i,f}$) and CO₂ plume footprints after simulated Year 6.

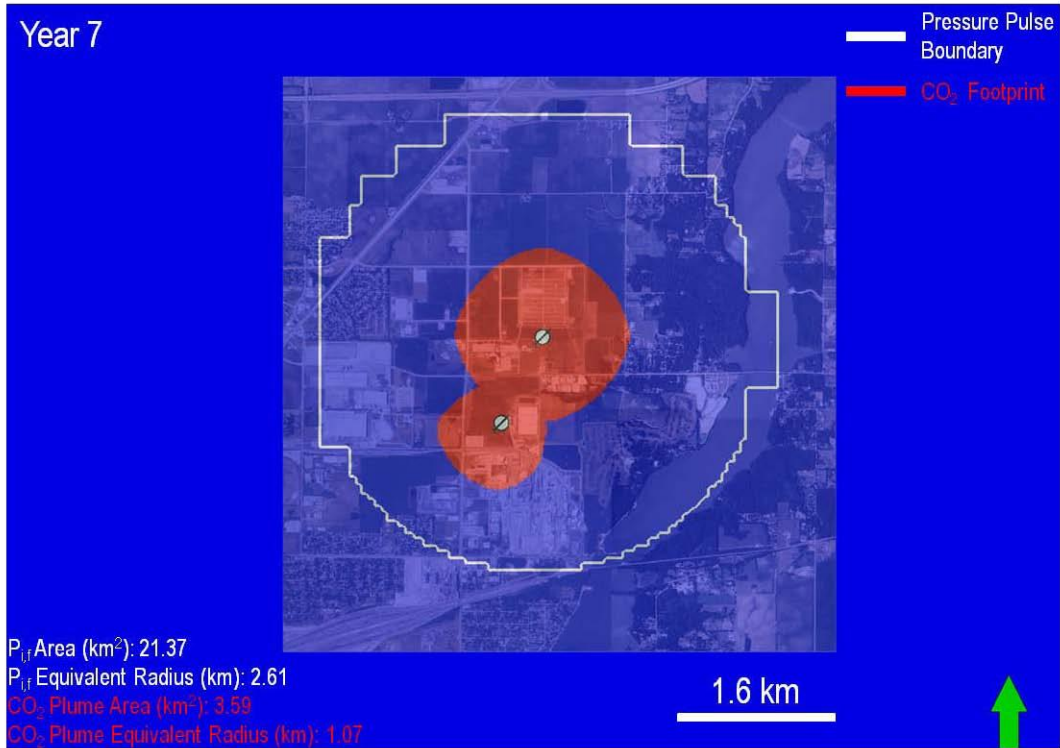

Figure 5-15: Map-view of pressure front ($P_{i,f}$) and CO₂ plume footprints after simulated Year 7.



Figure 5-16: Map-view of pressure front ($P_{i,f}$) and CO₂ plume footprints after simulated Year 8.

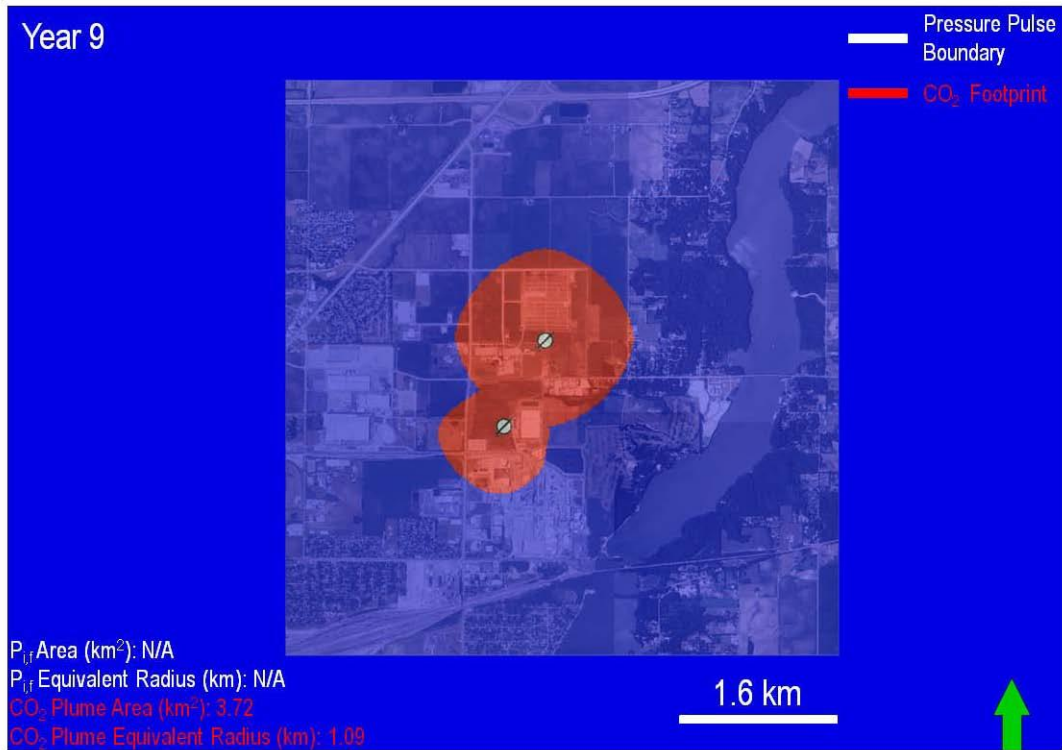

Figure 5-17: Map-view of pressure front ($P_{i,f}$) and CO₂ plume footprints after simulated Year 9.



Figure 5-18: Map-view of pressure front ($P_{i,f}$) and CO₂ plume footprints after simulated Year 15.



Figure 5-19: Map-view of pressure front ($P_{i,f}$) and CO₂ plume footprints after simulated Year 20.



Figure 5-20: Map-view of pressure front ($P_{i,f}$) and CO₂ plume footprints after simulated Year 30.

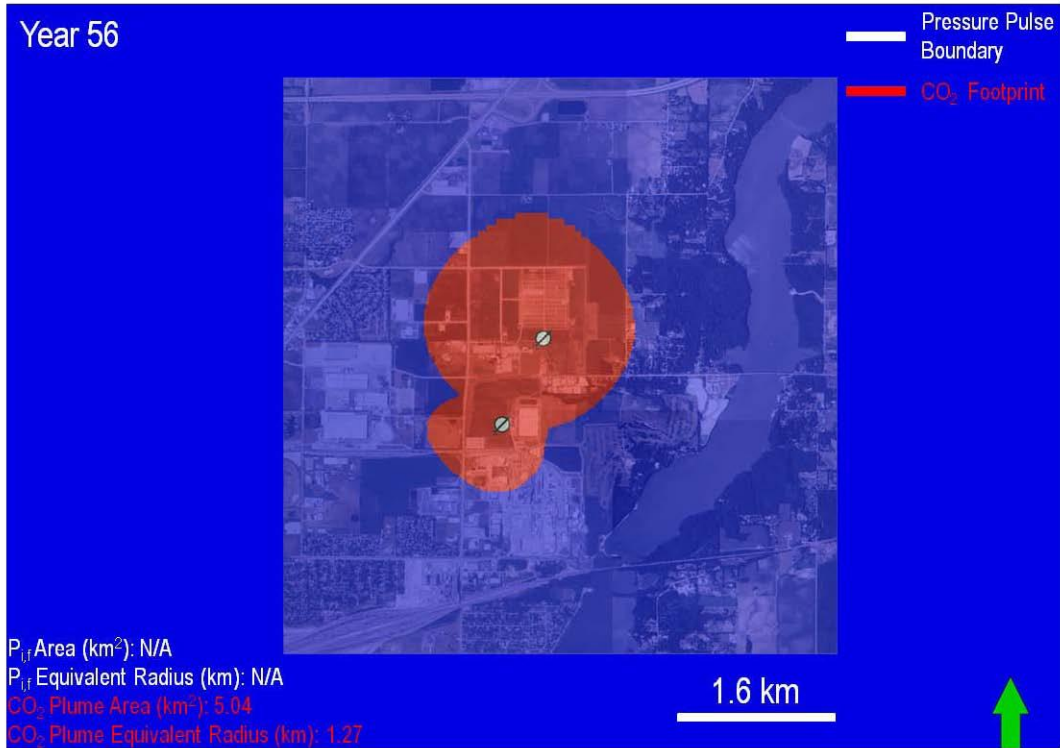

Figure 5-21: Map-view of pressure front ($P_{i,f}$) and CO₂ plume footprints after simulated Year 56.

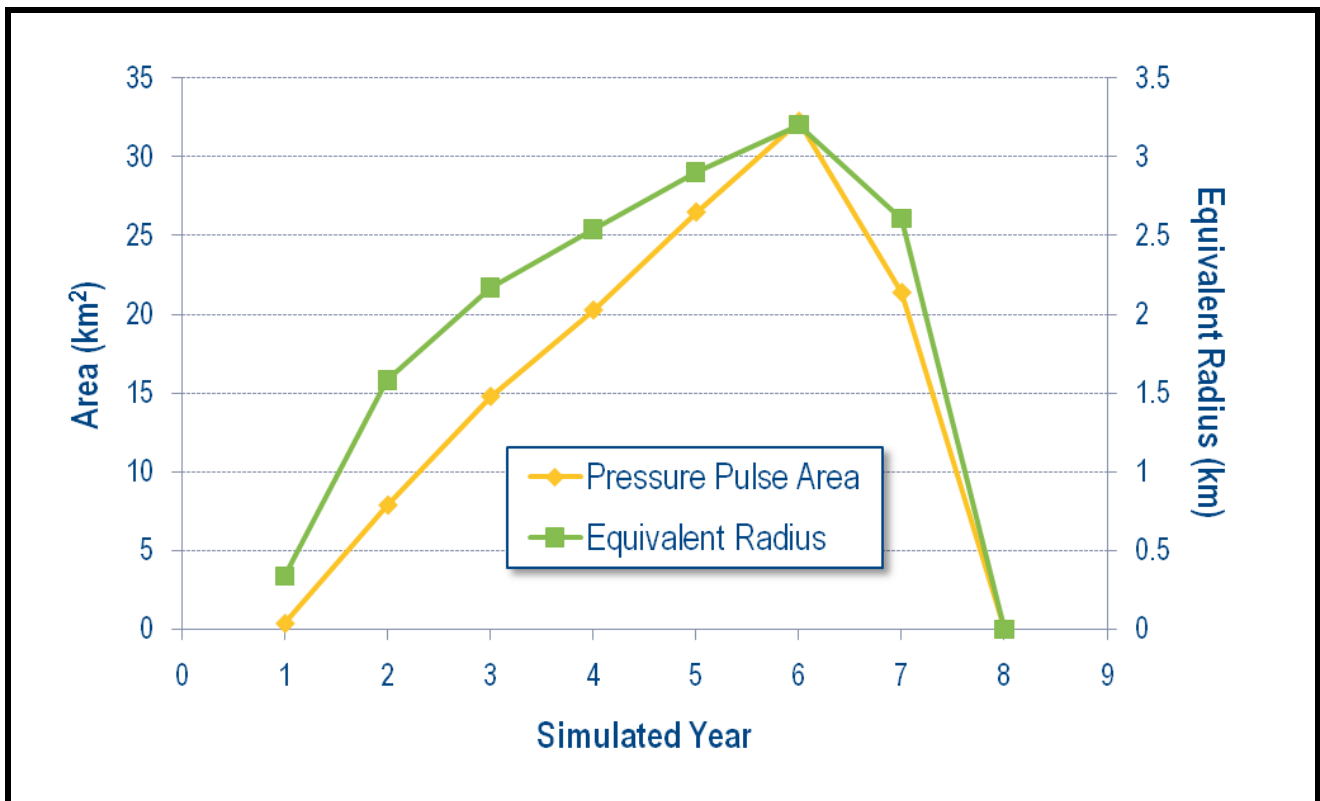

Figure 5-22: Graph of pressure front ($P_{i,f}$) area and equivalent radius throughout simulated time.

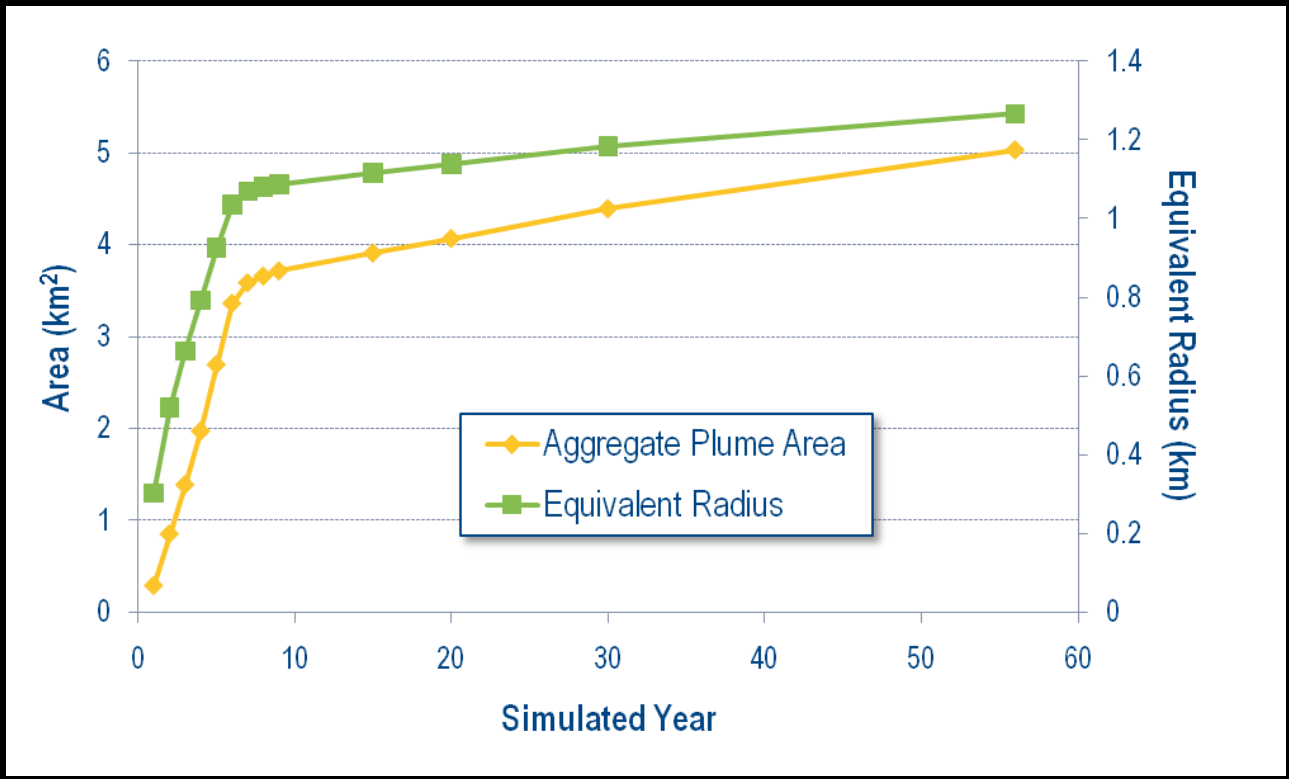

Figure 5-23: Graph of CO₂ plume area and equivalent radius throughout simulated time.

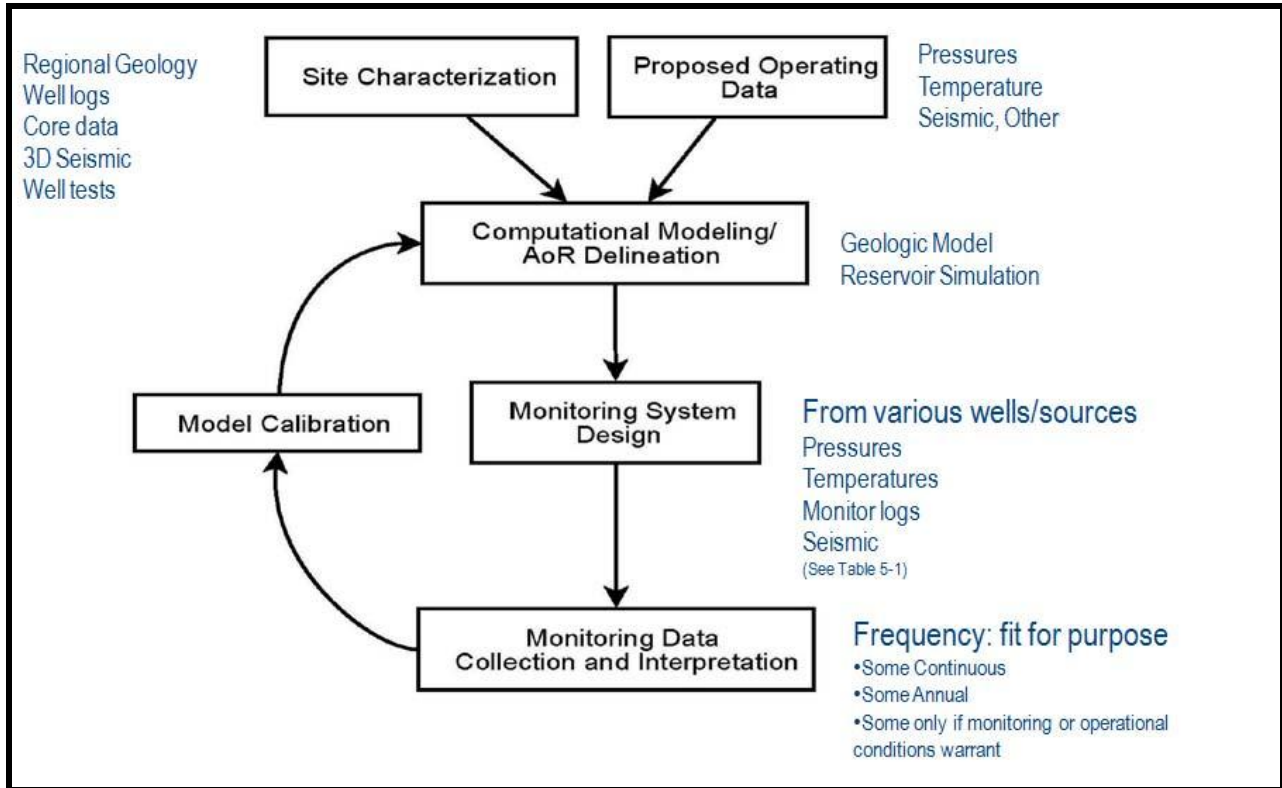

Figure 5- 24: AOR Corrective Action Plan Flowchart (Reference: Draft Underground Injection Control (UIC) Program Class VI Well Area of Review Evaluation and Corrective Action Guidance for Owners and Operators, US EPA 2011)

| | IL ICCS Wells | | | IL IBDP Wells | | |
|--|---------------|------|------|---------------|------|------|
| | CCS#2 | VW#2 | GM#2 | CCS#1 | VW#1 | GW#1 |
| Approx. Depth (ft) | 7200 | 7200 | 3500 | 7200 | 7200 | 3500 |
| Approx. Distance from CCS#2 (ft) | 0 | 3000 | 300 | 3950 | 2950 | 4050 |
| <u>Capable of obtaining:</u> | | | | | | |
| Mt. Simon pressure(s)/temperature(s) | yes | yes | no | yes | yes | no |
| Mt. Simon fluid sampling | no | yes | no | no | yes | no |
| Ironton Galesville pressure/temperature | no | no | no | no | yes | no |
| Ironton Galesville sampling | no | no | no | no | yes | no |
| St. Peter pressure/temperature | no | no | yes | no | no | no |
| St. Peter fluid sampling | no | no | yes | no | no | no |
| RST Logging (near wellbore CO ₂ detection) | yes | yes | yes | yes | yes | yes |
| Seismic Imaging of CO ₂ plume | no | no | yes | no | no | yes |
| Annulus Pressure at surface | yes | yes | yes | yes | yes | yes |
| Injection Pressure at surface | yes | no | no | yes | no | no |
| * Deeper formations only. Shallow USDW monitoring not included in this table | | | | | | |

Table 5-1: Monitoring System Capability for IL-ICCS Injection Site.

SECTION 6A – INJECTION WELL MONITORING, INTEGRITY TESTING, AND CONTINGENCY PLAN

This section is intended to satisfy the requirements of 40 CFR 146.90.

6A.1 Fluid Sampling and Analysis

6A.1.1 Sampling Frequency

As detailed in Section 7 of this application, the injection stream is high pure CO₂ with trace levels of other constituents. The CO₂ vent stream from biofuel fermentation is relatively consistent with respect to composition and mass due to the nature of the process and also a result of the operation of the vent scrubber system to remove volatile organic compounds. The scrubber system operates within established parameters in accordance with air permitting requirements. Based on these stream characteristics, quarterly sampling of the CO₂ is proposed.

6A.1.2 Analysis Parameters

Each sample will be analyzed for the parameters listed in Appendix E – Material Analysis Plan.

6A.1.3 Sampling Location

Sampling will be conducted downstream of the vent scrubber. The locations and details of the sample points are undetermined. The finalized sample point design and locations will be included in the well completion report.

6A.1.4 Detailed Fluid Analysis Plan

A detailed material analysis plan is included as Appendix E.

6A.2 Monitoring Program

Multiple wells and multiple techniques will be utilized to monitor the injection zone, other zones above the caprock, and the shallow groundwater zones. The monitoring data will be used to validate modeling techniques used in predicting the distribution of the CO₂.

In addition to monitoring at the injection well, the operator will drill and complete one (1) verification well that penetrates the Mt. Simon formation in order to provide another injection zone monitoring point. Other site monitoring includes the use of geophone well. Details on the monitoring techniques used in the verification well and the geophone well are described in Sections 6B and 3C, respectively.

Monitoring at the injection well will include annual surveys which are described in Section 6A.3.2. Details about the continuous operational monitoring are described below.

6A.2.1 Recording Devices

All essential monitoring, recording, and control devices will be functional prior to injection operations. Essential operational monitoring will be continuous and includes: injection flow rate and volume, well head injection pressure, well head injection temperature, and well head casing annulus pressure. Regarding the annular pressure, monitoring this parameter will provide the information necessary to determine whether there is a failure of the casing-cement bond, injection tubing, and/or down hole isolation devices - packers. Regarding the injectate, the CO₂ is a dry supercritical fluid, therefore no pH recording devices are warranted; however corrosion coupons will be installed to indirectly monitor corrosion on the process piping and equipment. This plan is fully described in Section 6A.3.5 - Corrosion Monitoring Plan.

6A.2.2 Control and Alarm System for the Well Monitoring and Maintenance

Alarms and shutdown systems will be installed and functional prior to injection operations. In order to meet the permit requirements, alarm and shutdowns systems will be initiated for deviations on essential operating parameters. These parameters include injection flow rate and volume, well head injection pressure, and well head casing annulus pressure. During shutdown events, the master control and monitoring system will be programmed to take the appropriate action for each specific event in order to safeguard the facility. Actions may include but are not limited to wellhead isolation, pipeline isolation, system venting (de-pressuring), and process equipment shutdown. Table 6A-1 lists the essential surface injection operating parameters

Table 6A-1: Surface injection operating parameters.

| Surface Injection Parameter | Operating Range |
|-------------------------------------|--------------------------------|
| CO ₂ Injection Flow Rate | Up to 3,300 metric tons/day |
| Flow Rate Variation | +/- 10% of flow rate set point |
| Wellhead Inlet Pressure | < 2,380 psig |
| Annulus pressure at surface | > 500 psig |

6A.2.2.1 Control System Overview

The surface facility's process flow diagrams (PFDs), which include the compression, dehydration, and transmission equipment, are provided in Section 4 – Injection Well Operation, while the piping & instrument diagrams (P&IDs) for these facilities can be found in Appendix C. These diagrams detail the facility's equipment, configuration, instrumentation, surveillance, and control systems. A process narrative describing the facility's equipment and control equipment is presented in Section 6A.2.2.3 – Surface Facility Equipment & Control System Description.

6A.2.2.2 Wellbore and Wellhead Design

The design of the injection well includes but is not limited to the following:

1. A dual master and single wing Xmas tree assembly with a swab valve above flow tee. Upper master will have an automatic shutoff capability. Wing valve will have an automatic valve (current design calls for a check valve) installed directly upstream of the wing valve to prevent backflow into the pipeline.

2. All annuli will have pressure gauges and sensors to detect any abnormal pressure spikes.
3. Injection pressures will be monitored and recorded at the compressor discharge and at the wellhead. Additionally, the pressure of the wellhead casing annulus will be monitored and recorded.
4. Along with continuous, real time recording and automatic shut-down systems, field operations personnel will perform daily rounds and routine inspections of the compression, dehydration, and transmission facilities as well as the well sites to ensure the integrity of the surface systems and apparent functionality of mechanical equipment.
5. All Xmas tree equipment is rated to at least 3,000 psig working pressure, plus the Xmas tree assembly (upper valve assembly) is constructed of stainless steel and/or chrome. Based on expected bottomhole pressures and other well controls and limitations, we will not exceed the working pressure of the 3,000 psi well head in any application or under any operating conditions. The maximum calculated injection pressure is 2,380 psig.
6. Normal operating pressure at the wellhead will be 2,380 psig or less. Alarms will be set at 2,350 psig and automatic shutdown will occur at 2,380 psig. Maximum surface injection pressure at the wellhead will be 2,380 psig.

The operating range of surface facilities instruments will address the minimum and maximum expected operating conditions for each instrument (surface pressure gauges, temperature gauge, annulus pressure gauges, etc.). The instruments will include an operating range that is at least 20% outside the expected maximum and (if required) minimum operating range.

If communication (and subsequent data archiving) is lost for any reason with any portion of the monitoring system, an investigation will immediately be conducted to determine the cause, and actions taken to restore communications. Injection will be shut down only under certain circumstances (reference the contingency plan in Section 6A.4). In the special case of wellhead surface pressure and annulus pressure, if communication is lost for greater than 30 minutes, project personnel will perform field monitoring of manual gauges every four hours for both parameters and record the data until communication is restored. An example of a form for maintaining the record is included in Figure 6A-1.

6A.2.2.3 Surface Facility Equipment & Control System Description

The description of the equipment and operating controls for the Surface Facilities is as follows (reference Piping & Instrument Diagrams (P&IDs) in Appendix C):

Collection and Blower Area

The P&IDs detail the surface facility's equipment, configuration, instrumentation, surveillance, and control systems. The compression train receives the low pressure (~0.5 psig) CO₂ from the primary CO₂ scrubber's overhead, gas outlet, line. From the scrubber, the CO₂ gas stream is sent to the blower inlet separators, TK-501/2, where condensed liquid, mainly free water carried over from the scrubber, is removed. The water level in the separators is controlled via start/stop of the inlet separators water pumps through level transmitters/controller LT-501/2. The pressure (PTX-501A/2A) and temperature (TIT-501A/2A) of the separators overhead CO₂ gas stream are measured before the stream enters the blowers, BL-501/2, where the CO₂ pressure is increased by approximately 16 psi. The blower outlet temperature and pressure are monitored and alarmed by TIT-501B/2B and PTX-501B/2B. At this point, the CO₂ stream is monitored for oxygen by an online gas analyzer ARX-001. A high oxygen reading may indicate an air leak or instrument failure that would allow air into the system through a flange leak or through the CO₂ scrubber's vent stack. In the event of high oxygen alarm, the operational staff would initiate steps to determine the source of the alarm condition and to take corrective action. After compression, the gas stream is cooled by the blower aftercooler exchanger, HE-501. The cooler outlet gas temperature is measured by TIT-503A and controlled at a set point (95°F) via TCV-503A; located on the exchanger's cooling water return line. The exchanger's cooling water inlet and outlet conditions are indicated by TI-502/3 and PI-503.

Next, the CO₂ stream enters the blower after cooler separator, TK-503, where any condensed liquid is removed. The water inventory in TK-503 is controlled by level controller LIC-502 via control valve LCV-502. The blower's discharge stream pressure is controlled by PTX-502B via variable frequency drive, VFD-502, controlling the blower motor, BLM-503. This control system is not shown on the enclosed PIDs but will be detailed on the finalized construction PIDs and included with the well completion report. Additional high pressure control is provided by PIC-502 located on TK-503's overhead gas outlet line which safely vents the CO₂ to atmosphere via control valve PCV-502. After cooling and water removal, the CO₂ stream is transported to the main compression building through 1,500 feet of 24" line. At the compression building, the CO₂ stream is split and enters the suction of four reciprocating compressors, K-600/700/800/900. Each compressor operates in parallel and is a six throw (cylinder) machine with 4-stages of compression.

Main Compression Area – Stages 1-3

During CO₂ compression, each stage follows a sequence of free liquid removal, pulsation dampening, compression, pulsation dampening, and cooling before moving to the next compression stage. The following paragraph provides a process narrative for K-600. The other compressors will have identical equipment and control elements.

In the 1st stage of compression, the CO₂ stream enters the 1st stage scrubber, SR-601, where any free liquid is removed. The scrubber level is controlled by LIC-601 via control valve LCV-601. The compressor's feed stream conditions (suction side) are indicated and alarmed by TIT-601A

and PTX-601A. After liquid knock out, the CO₂ stream passes through the 1st stage suction (pulsation) bottle, K-601A, before being compressed in cylinders #1 and #3. In this stage, the gas is compressed to 75 psia, after which it passes through the 1st stage discharge (pulsation) bottle, K-601B. High compressor discharge temperature is monitored and alarmed by TIT-601B/C. Pressure safety valves, PSV-601C/D, provide over pressure protection on the compressor discharge. Next, the gas is cooled to 95°F by the 1st stage intercooler, HE-601, before moving to the 2nd stage of compression.

In the 2nd stage, the CO₂ stream passes through the 2nd stage scrubber, SR-602, where any free liquid is removed. The scrubber level is controlled by LIC-602 via control valve LCV-602. The 2nd stage suction conditions are indicated and alarmed by TIT-602A and PTX-602A. After liquid knock out, the CO₂ stream passes through the 2nd stage suction bottle, K-602A, before compression to 249 psia in cylinders #2 and #4. The compressor discharge temperature is monitored and alarmed by TIT-602B/C. Pressure safety valves, PSV-601A/B, provide over pressure protection on the compressor discharge. Next the compressed CO₂ stream passes through the 2nd stage discharge bottle, K-602B, and is cooled to 95°F in the 2nd stage intercooler, HE-602, before moving to the 3rd compression stage.

In the 3rd compression stage, the CO₂ stream enters the 3rd stage suction scrubber, SR-603, where free liquid is removed. The scrubber level is controlled by LIC-603 via control valve LCV-603. The 3rd stage suction conditions are monitored and alarmed by TIT-603A and PTX-603A. After liquid removal, the CO₂ stream passes through the 3rd stage suction bottle, K-603A, followed by compression to 598 psia in cylinder #6, before traveling through the 3rd stage discharge bottle, K-603B. The compressor discharge temperature is monitored and alarmed by TIT-603B/C. Pressure safety valves, PSV-603A/B, provide over pressure protection on the compressor discharge. Next, the gas is cooled to 95°F by the 3rd stage intercooler, HE-603, before further processing.

Dehydration Area

At this point in the process, 95% of the water entering with the CO₂ stream has been removed through compression and cooling. After the third stage of compression, the CO₂ stream contains approximately 1300 ppmwt H₂O. Because this exceeds the recommended water content for subsurface injection, the four streams are combined to be sent to the glycol dehydration skid, shown in PD-09/10.

The design basis for the dehydration unit is to remove enough water from the CO₂ stream to insure the exiting stream contains no more than 30 lbs of H₂O per mmscf of CO₂, approximately 265 ppmwt H₂O. Dehydration with tri-ethylene glycol (TEG) typically produces a CO₂ stream with a water content of less than 7 lbs per mmscf of CO₂ (60 ppmwt H₂O). Based on an inlet feed gas composition of 151 lbs H₂O/mmscf, the unit's water removal capacity is 173 lbs/hr yielding a final CO₂ stream with water content of 11 lbs H₂O per mmscf CO₂ (60 ppmwt H₂O).

After the 3rd compression stage, the four streams are combined and enter the dehydration inlet separator, TK-751, where any free liquid is removed. After liquid removal, the gas stream enters the bottom of the TEG glycol contactor, VS-751, where it is contacted with lean (water-free) glycol introduced at the top of the contactor. The glycol removes water from the CO₂ by physical absorption and the rich glycol (water saturated) exits the bottom of the column. The dry CO₂ stream leaves the top of the contactor and passes through the glycol heat exchanger, HE-

751, where the gas is cooled to 95°F, via cross exchange with lean glycol, before returning to the compression section.

Regarding the rich glycol stream, after leaving the contactor it is cross exchanged with the regenerator O/H vapor stream in the reflux condenser coil in the top of the glycol still, VS-752. Next this stream is further heated by cross exchange with the regenerator bottoms (lean glycol) stream in the cold glycol exchanger, HE-752. Next the stream enters the glycol flash tank, TK-752, where any non-condensable vapors are removed by venting through PCV-751.

After leaving the flash vessel, the glycol is filtered and polished by FR-754A/B, glycol solids filter, and FR-755A/B, rich glycol carbon filter. Next, additional heating of the rich glycol occurs by cross-exchange with the regenerator bottoms (lean glycol) in the hot glycol exchanger, HE-753, before entering the glycol still column, VS-752. The glycol regeneration equipment consists of a column, an overhead condenser coil, and a reboiler, HE-755. In the still column, the glycol is thermally regenerated via hot vapor stripping the water from the liquid phase.

The hot lean glycol exits the bottom of the tower and enters the reboiler where it is heated and any remaining water is flashed into vapor (steam). The steam returns to the bottom of the tower where it acts as the stripping agent removing water from the rich glycol descending the still. Excess lean glycol in the reboiler flows over a level weir and enters a glycol surge tank. Next the hot lean glycol gravity flows through the previously described cross exchangers (HE-752/753) where it is cooled by the rich glycol. Finally the glycol pumps, PU-752A/B pressurizes the lean glycol, after which it is cooled through cross exchange with dry CO₂ in HE-751, and returns to the top of the glycol contactor, VS-751, starting another process cycle.

After dehydration the CO₂ stream is monitored and alarmed for water content by gas analyzer ARX-006 (see PD-21), after which the stream is split and returned to the four compressors 4th stage.

Main Compression Area – Stage 4 and Booster Pumps

As with the previous compression stages, the CO₂ stream enters the 4th stage suction scrubber, SR-604, where any free liquid is removed. The scrubber level is controlled by LIC-604 via control valve LCV-604. The compressor's feed stream conditions (suction side) are indicated and alarmed by TIT-604A and PTX-604A. After liquid knock out, the CO₂ stream passes through the 4th stage suction (pulsation) bottle, K-604A, before being compressed in cylinder #5. In this stage, the gas is compressed to 1425 psia, after which it passes through the 4th stage discharge (pulsation) bottle, K-601B. High compressor discharge temperature is monitored and alarmed by TIT-601B/C. Next, the gas is cooled to 95°F by the 4th stage aftercooler, HE-704A/B, before further compression. The compressor's discharge pressure control is accomplished by PIC-604C via PCV-604C, which recycles gas to the 1st stage scrubber, SR-601. Additional high pressure control is provided by pressure relief valve PSV-604A/B, which safely vents the stream to atmosphere.

After cooling, the CO₂ streams are combined and sent to the CO₂ multistage centrifugal pumps, PU-754A/B/C. Here the CO₂ stream is in a dense phase and is compressed to 2,565 psia and transported to the injection well by 5,000 feet of 8" pipeline. Flow to the wellhead is monitored by flow indicating transmitter FIT-006 and is controlled by flow controller FC-006 by changing the set point on the pump's variable frequency drive, VFD-754A/B/C. Additionally a pressure

indicating transmitter, PIT-007 will provide a high pressure protection by allowing the pressure transmitter to reset the flow. The final high pressure control is provided on the pump discharge by pressure relief valves PSV-082/083/084(A/B), which safely vent the stream to atmosphere.

Transmission Line and Injection Well

As mentioned previously, the CO₂ stream is transported to the injection well via a 5,000 foot pipeline constructed of 8" schedule 120 carbon steel. The pipeline is equipped with automated block valves NV-023, located at the compressor building (see PD-13), and MOV-023, located at the wellhead (see PD-40), as part of the control system for isolating the pipeline and injection well during a shutdown event. At the injection well site, monitoring and alarm of stream parameters is accomplished with temperature indication TIT-009 and pressure indication PIT-012.

Additional overpressure protection is provided on the pipeline by two spring-operated thermal relief valves, TRV-001 and TRV-002. The purpose of these valves is to relieve pressure resulting from the thermal expansion of the fluid if the pipeline is isolated for a shutdown event.

Master Control and Surveillance System

Regarding the UIC Class VI permit conditions, the control system will limit maximum flow to 3,300 MT/day and/or limit the well head pressure to 2,380 ps ig, which corresponds to the regulatory requirement to not exceed 90% of the injection zone's fracture pressure. All injection operations will be continuously monitored and controlled by the ADM operations staff using the distributive process control system. This system will continuously monitor, control, record, and will alarm and shutdown if specified control parameters exceed their normal operating range.

The CO₂ compression, transmission, and injection system has a robust control and surveillance structure programmed to identify abnormal operating conditions and/or equipment malfunctions, automatically make the appropriate process response, annunciate the condition to ADM operations personnel staff, and to shut down the process equipment under certain conditions.

More specifically, all critical system parameters, e.g., pressure, temperature, and flow rate will have continuous electronic monitoring with signals transmitted back to a master control system. A list of these instruments, with the instrument description/location, tag number, type of instrument, brand/model number, service, compatibility and operating range information, will be provided within the well completion report. The list will also indicate whether the instrument activates a shutdown of the surface equipment. Real time monitoring for water and oxygen content is also included in the plant design. The recording devices, sensors and gauges will meet or exceed the maximum operating range by 20%.

ADM supervisors and operators will have the capability to monitor the status of the entire system in two locations: the compression control room (near the main compressors), and the main Alcohol Department control room. Should one of the parameters go into an alarm status, the control system logic will automatically make the necessary changes, including shutting down the entire compression system if warranted. At the same time, audible and visual alarms will activate in both the compression control room and the main Alcohol Department control room. Alcohol Department supervision will respond to the alarms, identify the problem, and dispatch the necessary resources to address the problem.

A loss of power to the compression system will shut down surface compression and injection. Automatic shutdown valves NV-023, located at the compressor building, and MOV-023, located at the wellhead, V-347 will automatically isolate the pipeline. Additionally, check valve at the wellhead will prevent the backward flow of CO₂ from the wellhead.

A Hazard and Operability Study (HAZOP) was conducted for the design of the CO₂ compression and dehydration portions of the Surface Facilities. The process nodes evaluated during the HAZOP were blower, reciprocating compression Stages 1, 2, 3 and 4, and the dehydration unit, centrifugal pump, pipeline, and wellhead systems. Engineering and administrative controls were specified for each of the consequences identified during the HAZOP.

6A.2.3 USDW Monitoring in Area of Review

In Macon County, Quaternary sand and gravel deposits are tapped as a source of drinking water for most domestic water wells. Some water wells are completed in the shallow bedrock, but water quality deteriorates rapidly with depth. Available information shows that sand and gravel deposits are not uniformly distributed throughout the county (Larson et al., 2003, Figure 6A-2) and may not be found continuously beneath the IL-ICCS site. The total range of well depths within the AoR is from two to 7,250 feet. Most water wells in the AoR have depths ranging from 70 to 101 feet (Figure 6A-3), which coincides with the depth of the upper Glasford Aquifer (Figure 6A-4). For the IBDP site, the Illinois EPA determined that the Pennsylvanian bedrock was the lowermost USDW. Because the IL-ICCS site is within one mile of the IBDP site, a similar determination should be applicable to the IL-ICCS site. Therefore the proposed shallow groundwater monitoring plan is based on the IBDP's approved groundwater monitoring plan.

6A.2.4 Detailed Groundwater Monitoring Plan

A detailed groundwater monitoring plan is provided in Appendix F of this application.

6A.2.5 Tracking Extent and Pressure of CO₂ plume

Both direct and indirect measurement of the extent and pressure of the carbon dioxide plume will be implemented. Direct measurements will be accomplished by downhole fluid sampling of the injection zone using the Westbay system in the verification well. Indirect measurements will include one or more of the following: acoustic measurements from the geophysical monitoring well, seismic surveys in the vicinity of the CCS #2 injection well, and reservoir saturation tool (RST) in the verification well.

6A.2.6 Surface Air and Soil Gas Monitoring

Potential Risks to USDW

Based on the injection zone depth within the Mt. Simon, the thickness of the Eau Claire formation confining unit, and the presence of multiple secondary seals, a scenario where CO₂ comes in direct contact with the site's USDW appears highly improbable. However, to assure that groundwater resources are adequately protected, a groundwater monitoring program will be conducted at the site. The lowermost USDW is not expected to be vulnerable to contamination resulting from the injection of CO₂ into the Mt Simon Sandstone. This is in part due to the presence of multiple hydrologic seals that are barriers to upward fluid movement. Within the Illinois Basin, thick shale units function as significant regional seals. These are the Devonian-age New Albany Shale, Ordovician age Maquoketa Formation, and the Cambrian-age Eau Claire Formation. There are also many minor, thinner Mississippian- and Pennsylvanian-age shale beds that form seals for known hydrocarbon traps within the basin. Regarding overlying seal(s) integrity, all three significant seals are laterally extensive and appear, from subsurface wireline correlations, to be continuous within a 100-mile radius of the test site.

Another important detail is the fact that the lowermost seal, the Eau Claire has no known penetrations within a 17-mile radius surrounding the site with the exception of the two sequestration-related wells at the IBDP site (CCS #1 and Verification Well #1), both of which are constructed to UIC Class VI specifications. Because the IBDP wells were recently constructed with special materials meeting UIC Class VI specifications (i.e. chrome casing and CO₂ resistant cement), their integrity is well known and documented.

The Illinois Basin has the largest number of successful natural gas storage fields in water bearing formations in the United States. These gas storage fields provide important analogs that can be used to analyze the potential for CO₂ sequestration. These analogs illustrate long-term seal integrity, injection capability, storage capacity, and reservoir continuity in the north-central and central Illinois Basin at comparable depths. Nearly 50 years of successful natural gas storage in the Mt. Simon Sandstone strongly indicated that this saline reservoir and overlying seals should provide successful containment for CO₂ sequestration.

Gas storage projects in the Illinois Basin all confirm that the Eau Claire is an effective seal in the northern and central portions of the Basin. Core analysis data from the Manlove Gas Storage Field, 45 miles to the northeast of the proposed site, show that the Eau Claire shale intervals have vertical and horizontal permeability less than 0.1 mD.

Regional cross sections in the central part of Illinois show that the Eau Claire Formation, the primary seal, is a laterally persistent shale interval above the Mt. Simon that is expected to provide a good seal. Drilling at the IBDP site shows that the Eau Claire should be approximately 500 feet thick at the IL-ICCS site (reference Section 2.5 of this application). As discussed in Section 2.5, the IL-ICCS site should have approximately 200 feet of sealing shale in the Eau Claire Formation directly above the Mt. Simon Sandstone.

The database of UIC wells with core from the Eau Claire was also used to derive seal qualities. This database shows that the Eau Claire's median permeability is 0.000026 mD and median

porosity is 4.7%. At the Ancona Gas Storage Field, located 80 miles to the north of the proposed ADM site, cores were obtained through 414 feet of the Eau Claire, and 110 analyses were performed on a foot-by-foot basis on the recovered core. Most vertical permeability analyses showed values of <0.001 to 0.001 mD. Only five analyses were in the range of 0.100 to 0.871 mD, the latter being the maximum value in the data set. Thus, even the more permeable beds in the Eau Claire Formation are expected to be relatively tight and tend to act as sealing lithologies.

There are no mapped regional faults and fractures within a 25-mile radius of the ADM site. New 2D seismic reflection data did not detect any faults or adverse geologic structures in the vicinity of the proposed well site (Section 2.2). The drilling of the injection well will yield data such as time-to-depth conversions, and will be used to design and execute a comprehensive 3D seismic data volume to further ensure that no seismically resolvable faults and fractures pose a threat to the integrity of the injection site. Moreover, there are no known unplugged, abandoned wells that penetrate the confining layer (Section 5.5).

Finally, it must be noted that a portion of the injected CO₂ will be converted to carbonic acid upon contact with the brine in the injection formation, but this is not expected to significantly impact the formation lithology. This is due to brine's pH being maintained above 2.0 because of pH-buffering reactions that will occur between the acidified brine and feldspar minerals within the Mt. Simon Sandstone.

6A.2.6.2 Surface Air Monitoring Plan

Due to the limited risk of USDW endangerment by CO₂ migration as discussed in Section 6A.2.6.1, and similarly the limited risk of migration to the atmosphere, surface air monitoring is not proposed for this permit.

6A.2.6.3 Soil Gas Monitoring Plan

Due to the limited risk of USDW endangerment by CO₂ migration as discussed in Section 6A.2.6.1, and similarly the limited risk of migration to the soil, soil gas monitoring is not proposed for this permit.

6A.2.7 *Periodic Review*

The testing and monitoring plan shall be periodically reviewed to incorporate collected monitoring and operational data. No less frequently than every 5 years, the most recent area of review shall be reevaluated and based on this review, an amended testing and monitoring plan, or demonstration that no revision is necessary, shall be submitted to the permitting agency. Any amendments to the testing and monitoring plan approved by the permitting agency, will be incorporated into the permit, and will be subject to the permit modification requirements as appropriate. Amended plans or demonstrations shall be submitted to the permitting agency:

- (1) Within one year of an area of review re-evaluation; or

(2) Following any significant changes to the facility, such as addition of monitoring wells or newly permitted injection wells within the area of review, on a schedule determined by the permitting agency; or

(3) When required by the permitting agency.

Figure 6A-3: Box plot of the water well depths within 2.5 mile radius of injection well site.

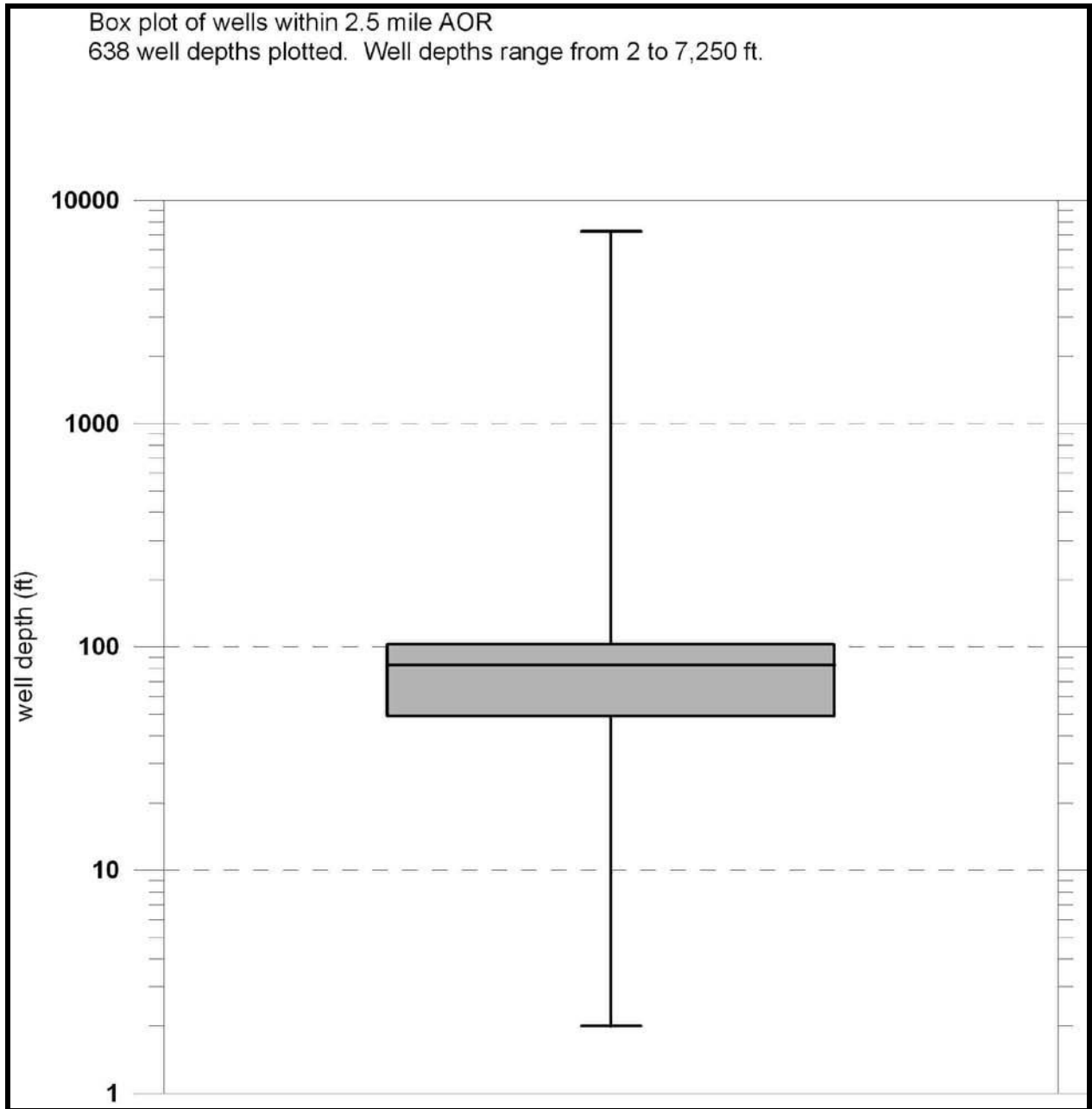

The box plot shows the distribution of the well depths. The bottom of the box marks the 25th percentile, the middle marks the median (50%) and the top marks the 75th percentile. The long whiskers mark the minimum and maximum. This graph was generated using 638 data points.

Figure 6A-4: Depth to the upper Glasford aquifer (modified from Larson et al., 2003). The IL-ICCS project site within T17N, R3E is shown in red.

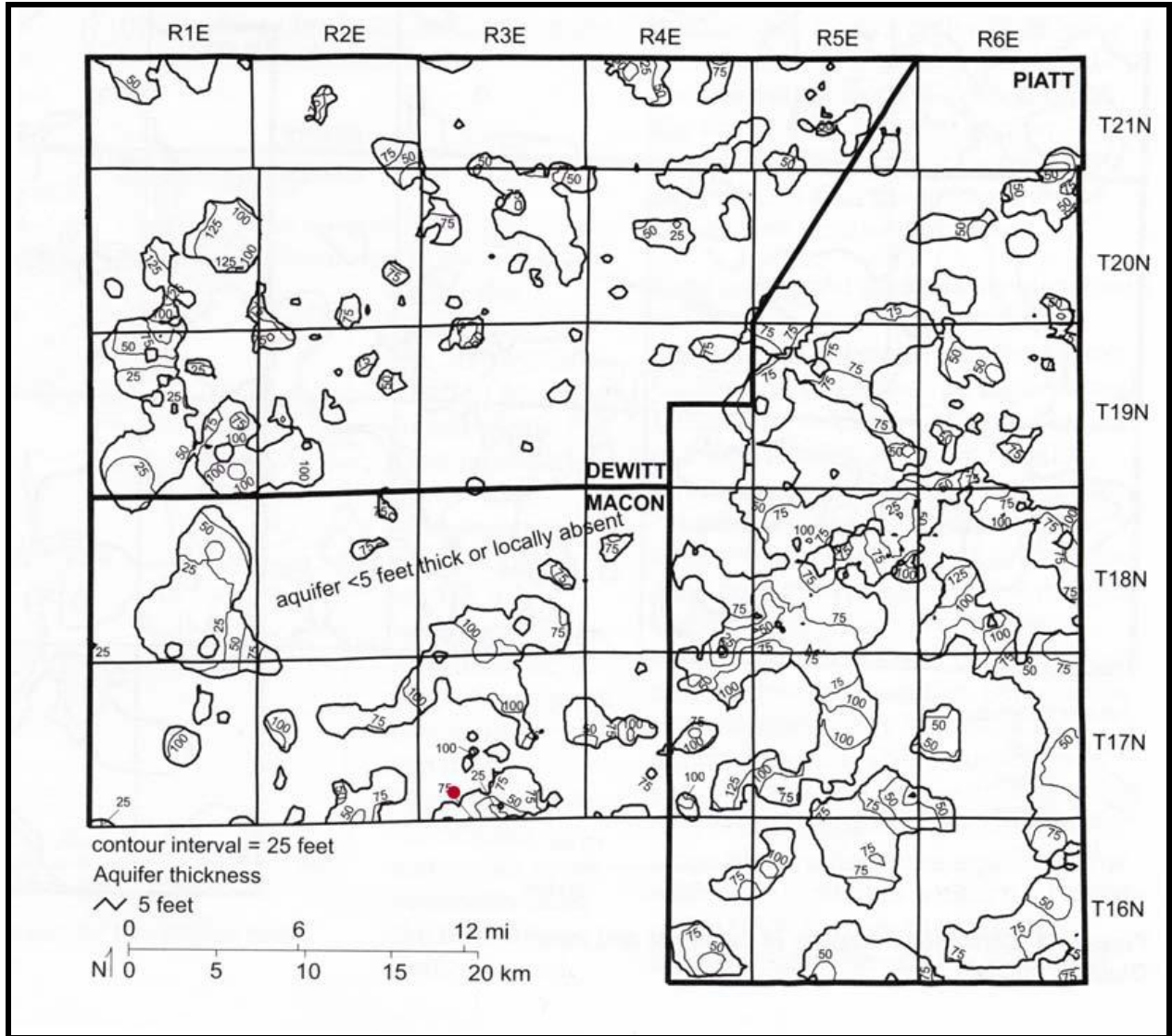

Figure 6A-5: Proposed locations of the IL-ICCS injection well and USDW monitoring wells.

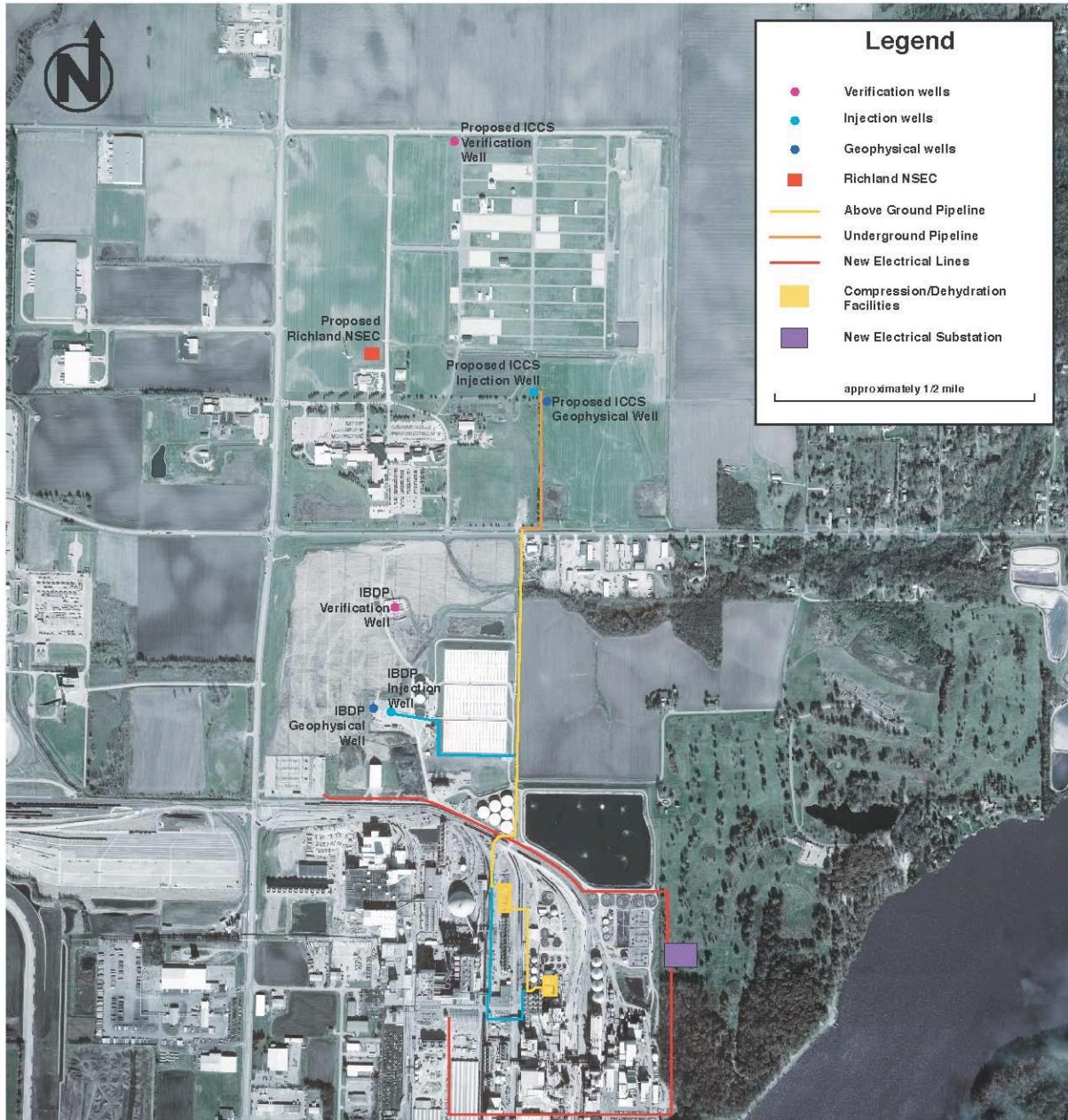
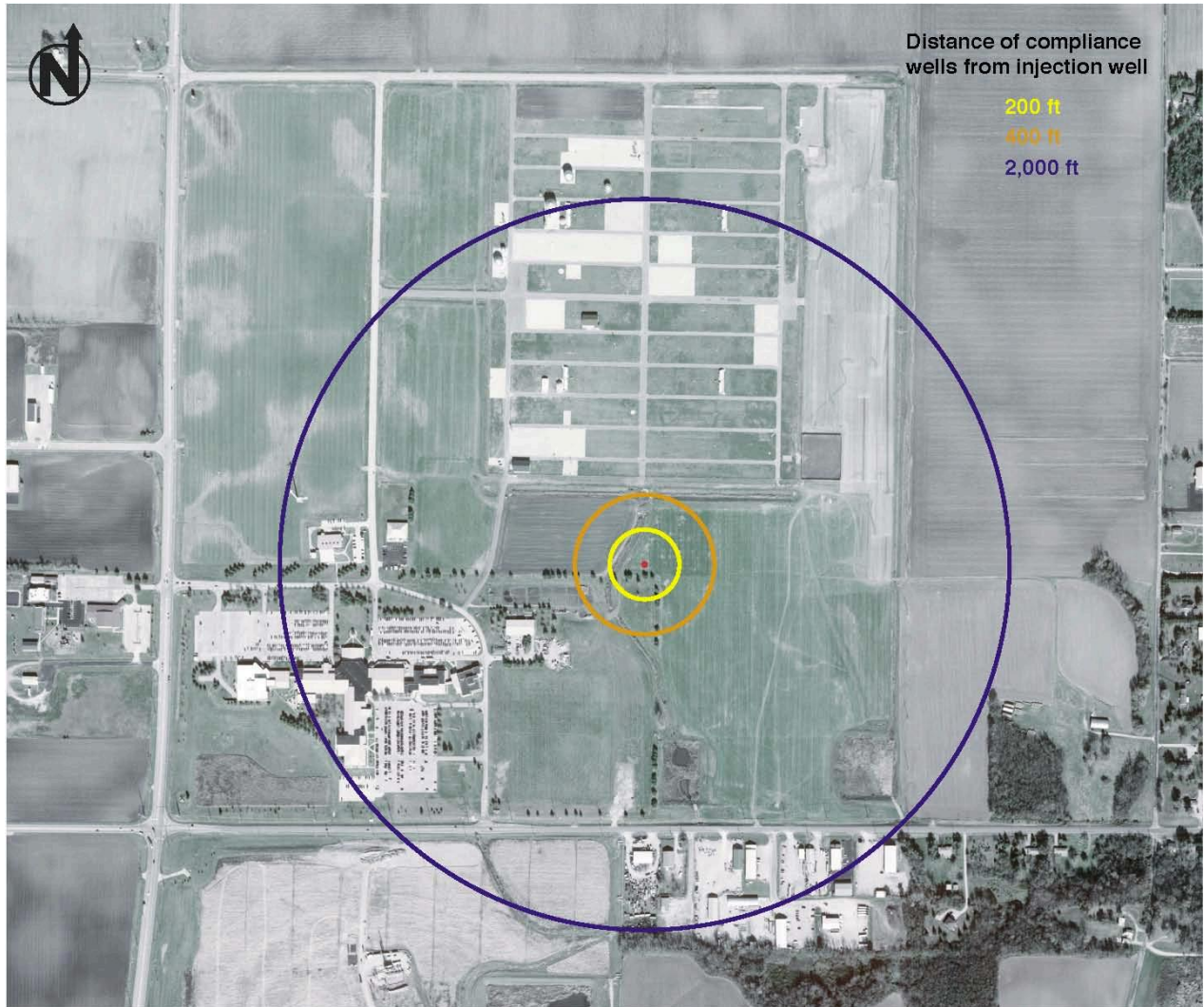

Figure 6A-6: Shallow Groundwater Compliance Well Locations.

Shallow ground water compliance wells will include two wells within 200 feet of the injection well, one additional well within 400 feet, and a fourth compliance well within 2000 feet of the CCS #2 injection well. The precise locations of these wells are yet to be determined and will be documented in the completion report.



6A.3 Mechanical Integrity Tests During Service Life of Well

6A.3.1 Continuous Monitoring of Annular Pressure

To verify the “absence of significant leaks,” the surface injection pressure, and the casing-tubing annulus pressure will be continuously monitored and recorded.

The following procedures will be used to limit the potential for any unpermitted fluid movement into or out of the annulus (see Section 3A.7.5):

- i. The annulus between the tubing and the long string of casing shall be filled with brine. The brine will have a specific gravity of 1.25 and a density of 10.5 lbs/gal. The hydrostatic gradient is 0.546 psi/ft. The brine will contain a corrosion inhibitor.
- ii. The surface annulus pressure will be kept at a minimum of 400 pounds per square inch (psi) at all times.
- iii. The pressure within the annular space, over the interval above the packer to the confining layer, shall be greater than the pressure of the injection zone formation at all times.
- iv. The pressure in the annular space directly above the packer shall be maintained at least 100 psi higher than the adjacent tubing pressure during injection. This does not include start-up and shutdown periods.

Figure 6A-7 shows the injection well annulus protection system. The annular monitoring system will consist of a continuous annular pressure gauge, a brine water storage reservoir, a low-volume/high-pressure pump, a control box, fluid volume measurement device, fluid, and electrical connections. The control box will receive pressure data from an annular pressure gauge and will be programmed to operate the pump as needed to maintain approximately 400 psi (or greater) on the annulus. A means to monitor the volume of fluid pumped into the annulus will be incorporated into the system by use of a tank fluid level gauge, flow meter, pump stroke counter or other appropriate devices.

The annulus pump will be a General Pump Co. Model 1321 (or similar device) triplex pump rated to 2,100 psi and a flow rate of 5.5 gpm. The pump will be powered by a 3.0 hp, 110/220V electric motor. Pressure will be monitored by the ADM control system gauges. The pump will be controlled by two pressure switches one for low pressure to engage the pump and the other for high pressure to shut the pump down. Anticipated range on the switches would be 400 psi or higher for the low pressure set point and 500 psi or higher for the high pressure set point. Annulus pressure will be monitored at the ADM data control system. A brine storage tank will be connected to the suction inlet of the pump. A hydrostatic tank level gauge will be installed in the brine storage tank with data fed into the ADM monitoring system. The brine in the storage tank will be the same brine as in the annulus. Any changes to the composition of annular fluid shall be reported in the next report submitted to the permitting agency.

As noted in Section 6A.2.2.2, if system communication is lost for greater than 30 minutes, project personnel will perform field monitoring of manual gauges every four hours or twice per shift for both wellhead surface pressure and annulus pressure, and record hard copies of the data

until communication is restored. An example of a form for maintaining the record is included in Figure 6A-1.

Average annular pressure and fluid volumes changes will be recorded daily and reported to the permitting agency as required.

Figure 6A-7: The annular monitoring system general layout.

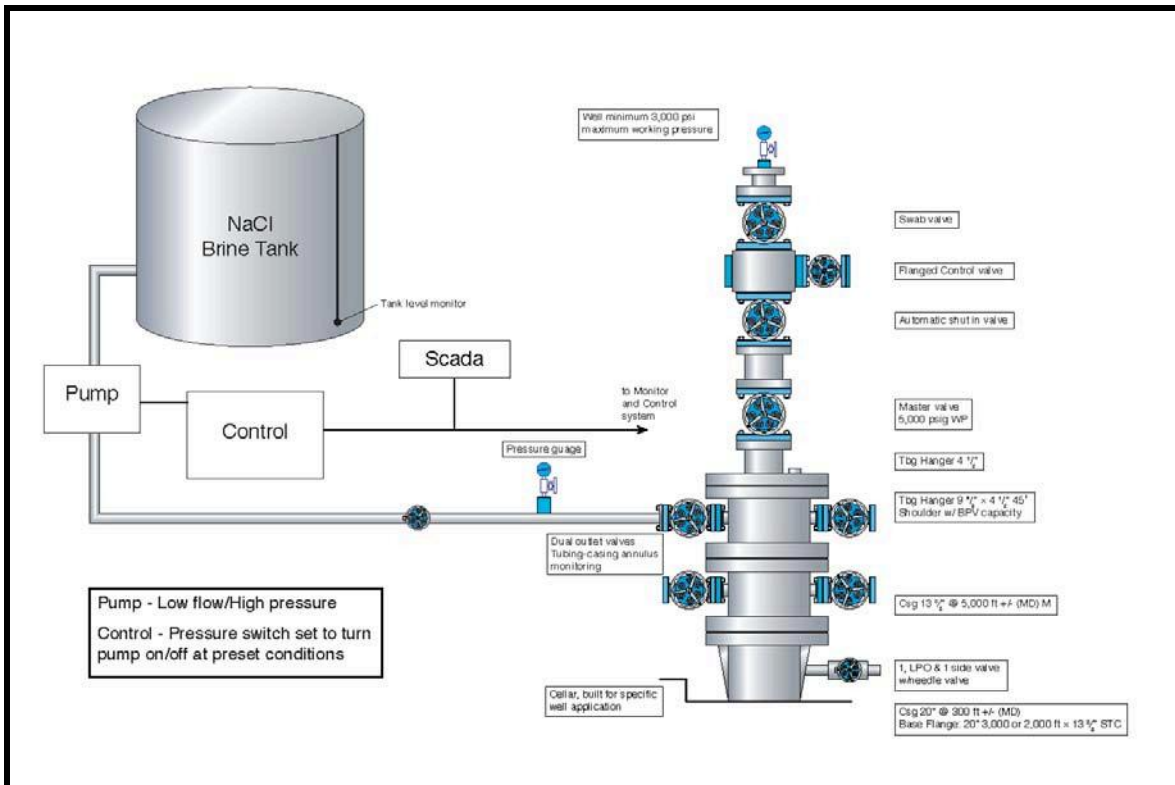

6A.3.2 Annual Testing

To ensure the mechanical integrity of the casing of the injection well, temperature data will be recorded at least annually across the wellbore from surface down to primary caprock. Bottom hole pressure data near the packer will also be provided.

Internal Mechanical Integrity will be demonstrated through the continuous monitoring of the annular system as described in the preceding section.

6A.3.3 Other Available Testing (If Conditions Warrant)

If required due to anomalous temperature data and to verify the “absence of significant fluid movement,” a Pulsed Neutron Capture / Sigma log (i.e. Schlumberger’s Reservoir Saturation Tool, or RST), can be run in the injection well from the base of the injection interval through the seal and across the porous zones above the seal. An initial RST will also be run before CO₂ injection to establish a good pre-CO₂ baseline to compare the post-CO₂ logging runs. The RST cased hole can be run through tubing such that the tubing and packer do not need to be removed during logging. The RST can also provide Sigma measurement through multiple strings of casing and tubing.

The logging tools can enter the wellbore through a lubricator at the surface, so it is not necessary to kill the well with another liquid. The tubing design is such that there are no restrictions so that the appropriate cased hole logging tools (e.g. RST, Temperature, Pressure) can pass through the tubing and log the near wellbore environment behind the casing.

Testing procedures can be found in Appendix G. Annular pressure will be measured at the surface continuously to check for increases or decreases in pressure.

Details of Schlumberger’s version of these tools are described below:

Pulsed Neutron Capture Logging

Reservoir Saturation Tool (RST) - Designed for reservoir complexity

Within the last decade, nearly every aspect of reservoir management has grown in complexity. What once was the exception is now routine: multiple-tubing and gravel pack completions, secondary and tertiary recovery, highly deviated wellbores, and three-phase production environments. The RSTPro* Reservoir Saturation Tool helps manage complexity by delivering reliable, accurate data. Run on the PS Platform string, with its suite of cased hole reservoir evaluation and production logging services, the RSTPro tool uses pulsed neutron techniques to determine reservoir saturation, lithology, porosity, and borehole fluid profiles. This information is used to identify bypassed hydrocarbons, evaluate and monitor reserves in mixed salinity and gas environments, perform formation evaluation behind casing, and diagnose three-phase flow independently of well deviation. Pulsed neutron technology.

An electronic generator in the RSTPro tool emits high-energy (14-meV) neutrons in precisely controlled bursts. A neutron interacts with surrounding nuclei, losing energy until it is captured. In many of these interactions, the nucleus emits one or more gamma rays of characteristic

energy, which are detected in the tool by two high-efficiency GSO scintillators. High-speed digital signal electronics process and record both the gamma ray energy and its time of arrival relative to the start of the neutron burst. Exclusive spectral analysis algorithms transform the gamma ray energy and time data into concentrations of elements (relative elemental yields).

Formation sigma, porosity, and borehole salinity

In sigma mode, the RSTPro tool measures formation sigma, porosity, and borehole salinity using an optimized Dual-Burst* thermal decay time sequence. The two principal applications of this measurement are saturation evaluation, which relies on measurement accuracy, and time-lapse monitoring, where sensitivity is determined by measurement repeatability. A new degree of accuracy in the formation sigma measurement is achieved by combining high-fidelity environmental correction with an extensive laboratory characterization database. The accuracy of RSTPro formation sigma is 0.22 cu for characterized environments and has been verified in the Callisto and American Petroleum Institute industry-standard formations. Formation porosity and borehole salinity are either computed in the same pass or input by the user. Exceptional measurement repeatability makes the RSTPro tool more sensitive to minute changes in reservoir saturation during time-lapse monitoring. The gains in repeatability and tool stability are the result of higher neutron output and sensor regulation loops. At the typical logging speed of 900 ft/hr [275 m/hr] for time-lapse monitoring, RSTPro repeatability is 0.21 cu.

Multifinger Imaging Tool

The PS Platform* Multifinger Imaging Tool (PMIT) is a multifinger caliper tool that makes highly accurate radial measurements of the internal diameter of the tubing string. The tool is available in three sizes to address a wide range of through-tubing and casing size applications. The tool deploys an array of hard-surfaced fingers, which accurately monitor the inner pipe wall. Eccentricity effects are minimized by equal azimuthal spacing of the fingers and a special processing algorithm, and the PMIT-B tool incorporates powerful motorized centralizers to ensure effective centering force even in highly deviated intervals. The inclinometer in the tool provides information on well deviation and tool rotation. The PMIT-C tool can be fitted with special extended fingers for logging large-diameter boreholes.

Applications

- Identification and quantification of corrosion damage
- Identification of scale, wax, and solids accumulation
- Monitoring of anticorrosion systems
- Location of mechanical damage
- Evaluation of corrosion increase through periodic logs
- Determination of absolute inside diameter (ID)

6A.3.4 Ambient Pressure Monitoring

A pressure falloff test can be conducted if required during injection to calculate the ambient average reservoir pressure. At least one pressure fall-off test shall be performed every 5 years in accordance with 40 CFR 146.90(f). The availability of pressure data from Verification Well #2 and Verification Well #1 (IBDP Project) will provide alternative sources of pressure monitoring of the injection zone. At a minimum, a planned pressure falloff test will be preceded by one week of continuous CO₂ injection at relatively constant rate. The well will be shut-in for at least

four days or longer until adequate pressure transient data are measured and recorded to calculate the average pressure. These data will be measured using a surface readout downhole gauge so a real-time decision on test duration can be made after the data is analyzed for average pressure. The gauges may be those used for day-to-day data acquisition or a pressure gauge will be conveyed via electric line (e-line).

Pressure Falloff Test Procedure

A pressure falloff test has a period of injection followed by a period of no-injection or shut-in.

Normal injection using the stream of CO₂ captured from the ADM facility will be used during the injection period preceding the shut-in portion of the falloff tests. The normal injection rate is estimated to be 3,000 MT/day (the last 3 years of the planned 5-year injection period). Prior to the falloff test this rate will be maintained. If this rate causes relatively large changes in bottomhole pressure, the rate may be decreased. Injection will have occurred for 10-11 months prior to this test, but there may have been injection interruptions due to operations or testing. At a minimum, one week of relatively continuous injection will precede the shut-in portion of the falloff test; however, several months of injection prior to the falloff will likely be part of the pre-shut-in injection period and subsequent analysis. This data will be measured using a surface readout downhole gauge so a final decision on test duration can be made after the data is analyzed for average pressure. The gauges may be those used for day-to-day data acquisition or a pressure gauge will be conveyed via electric line (e-line).

To reduce the wellbore storage effects attributable to the pipeline and surface equipment, the well will be shut-in at the wellhead nearly instantaneously with direct coordination with the injection compression facility operator. Because surface readout will be used and downhole recording memory restrictions will be eliminated, data will be collected at five second intervals or less for the entire test. The shut-in period of the falloff test will be at least four days or longer until adequate pressure transient data are collected to calculate the average pressure. Because surface readout gauges will be used, the shut-in duration can be determined in real-time. A report containing the pressure falloff data and interpretation of the reservoir ambient pressure will be submitted to the permitting agency within 90 days of the test. Pressure sensors used for this test will be the wellhead sensors and a downhole gauge for the pressure fall off test. Each gauge will be of a type that meets or exceeds ASME B 40.1 Class 2A (.5% accuracy across full range). Wellhead pressure gauge range will be 0-4,000 psi. Downhole gauge range will be 0- 10,000 psi.

6A.3.5 Corrosion Monitoring Plan

In order to monitor the corrosion potential of materials that will come in contact with the carbon dioxide stream, the following plan has been developed.

Sample Description

Samples of material used in the construction of the compression equipment, pipeline and injection well which come into contact with the CO₂ stream will be included in the corrosion monitoring program either by using actual material and/or conventional corrosion coupons. The samples consist of those items listed in Table 6A-2 below. Each coupon will be weighed, measured, and photographed prior to initial exposure (see Sample Monitoring section for measurement data).

Table 6A-2: List of Equipment Coupon with Material of Construction.

| Equipment Coupon | Material of Construction |
|------------------------|--------------------------|
| Pipeline | CS XPI5L-X52 |
| Long String Casing | Chrome alloy |
| Injection Tubing | Chrome alloy |
| PS3 Mandrel | Chrome alloy |
| Wellhead | Chrome alloy |
| Packers 1 | Chrome alloy |
| Compression Components | 316L SS |

Sample Exposure

Each sample will be attached to an individual holder (Figure 6A-8) and then inserted in a flow-through pipe arrangement (Figure 6A-9). The corrosion monitoring system will be located downstream of all process compression/dehydration/pumping equipment (i.e., at the beginning of the pipeline to the wellhead). To accomplish this, a parallel stream of high pressure CO₂ will be routed from the pipeline through the corrosion monitoring system and then back into a lower pressure point upstream in the compression system. This loop will operate any time injection is occurring. No other equipment will act on the CO₂ past this point; therefore this location will provide representative exposure of the samples to the CO₂ composition, temperature, and pressures that will be seen at the wellhead and injection tubing. The holders and location of the system will be included in the pipeline design and will allow for continuation of injection during sample removal.

Figure 6A-8. Coupon Holder



Figure 6A-9. Flow-Through Pipe Arrangement

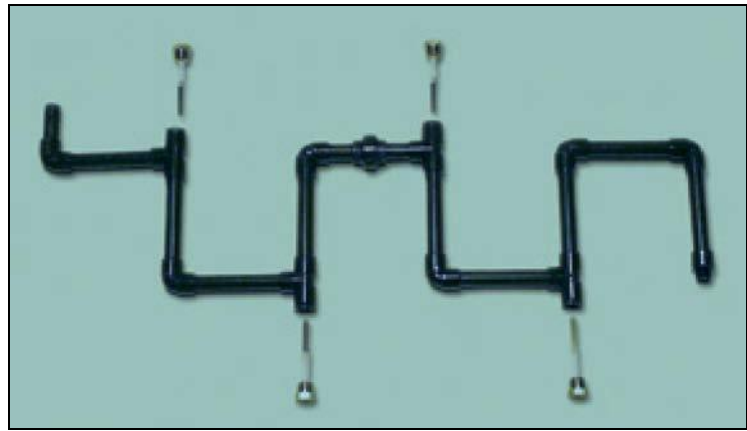

Sample Monitoring

The samples will be visually inspected and monitored on a quarterly basis for loss of mass, thickness, cracking, pitting, or other signs of corrosion. The sample holder will be removed from the CO₂ stream, and the samples will be removed from the holder for examination and measurements. Each coupon will be photographed and then be evaluated with the following precisions: Dimensional: 0.0001 inches; Mass: 0.0001 grams. The coupons will then be examined microscopically at a minimum of 10x power. Weights of the samples will be compared

with original weights to determine if there is any weight gain or loss that would indicate degradation.

Reporting

Dimensional and mass data, along with a calculated corrosion rate (in mils/yr), will be submitted with the facility's regular operating report following the analysis.

6A.4 Contingency Plan for Well Failure or Shut In

In addition to routine or scheduled maintenance and certain system testing procedures, injection will be shut down under the following conditions (see Appendix H for Emergency and Remedial Response Plan required under 40 CFR 146.94):

- Wellhead injection pressure reaches the automatic shutdown pressure of 2,380 psig. Fracture gradient was determined to be 0.715 psi per foot, or, for mid-perforation depth of 7,025 feet, the fracturing pressure would be 5,023 ps i. Using a CO₂ density of 47.31 lbs/cf with a hydrostatic gradient of 0.3285 psi/ft during injection, a wellhead pressure of 2,714 ps ig would be required to fracture the formation with a CO₂ of this density. The compression system has been designed and constructed for pressures up to 2,500 psig. The pipeline system has been designed and constructed for working pressure up t o 2,500 psig, based on the ASME code mandated stress analysis of the pipeline components. Therefore, the surface equipment is the pressure limitation and not formation fracturing pressure.
- Injection mass flow will be continuously monitored for instantaneous flow rate and total mass injected. At no time will a mass flow rate greater than 3,300 MT be injected in a "day". The electronic control system will be configured to shut down the injection system if the mass flow rate exceeds 3,300 MT per day for a set period of time (but in no case greater than 8 hours) or if the total mass injected for the "day" equals 3,300 MT. Such an arrangement will prevent an overly-high instantaneous injection rate from continuing unabated, while also ensuring that total mass injected does not exceed permit limits. Also, it is requested that a day be defined as the period from 6:00 a.m. to 5:59 a.m. to accommodate the data archiving system in place at the Decatur Plant.
- Surface temperature varies outside the permitted range.
- Failure to maintain the tubing/casing annulus pressure (measured at the surface) at greater or equal to 400 psig.
- Failure to maintain sufficient surface annular pressure (estimated at 400 to 500 psig but may vary according to injection pressures) to maintain a minimum differential of 100 psi between the downhole annular pressure and the adjacent tubing pressure just above the packer. (The annular pressure is to be higher than the tubing pressure.) Pressures are to be calculated from surface gauge readings.
- There is reason to suspect that the injection well or cap rock integrity has been compromised via one or more of the following:

- a. Failure of mechanical integrity testing as defined in the approved permit indicates CO₂ migration above the cap rock. These tests include annular pressure tests, time lapse sigma logging and temperature surveys.
- b. Shallow groundwater compliance monitoring shows a statistically significant change in groundwater quality that is a direct result of CO₂ injection. Groundwater monitoring procedures shall be defined in the approved permit.

Above listed limits apply to the injection of CO₂ except during startup, testing and shutdown periods (as defined by the approved permit). At no time will injection pressures exceed the pressure that could initiate fracturing of the injection zone and/or cap rock.

If a shutdown occurs by any of the control devices, an immediate investigation will be conducted. The condition will be rectified or faulty component repaired and system will be restarted.

If the system is shutdown due to sub-surface or wellbore related issues, an investigation will be undertaken as to the cause of the event that initiated the shutdown. A series of steps can be taken to address the loss of mechanical or wellbore integrity and determine if the loss is due to the packer system or the tubing by isolating the tubing above the packer. RST logs may be run to determine well bore integrity status. In the event of a shutdown due to a subsurface related issue, adequate time will be required to develop a workover plan and to mobilize the required equipment. If a major workover is required, the well can be sealed off by placing a blanking plug in the tailpipe below the packer, and the well loaded with kill-weight brine while plans are developed as to how to best approach the workover.

6A.4.1 Persons Designated to Oversee Well Operations

A site-specific list of persons designated to oversee well operations in the event of an emergency shall be developed and maintained during the life of the project.

6A.5 Quality Assurance Plan

Data collected by the operator for testing and monitoring of the Class VI injection well will be subject to verification by an independent laboratory or, if compiled in-house, will be subject to verification using in-house quality assurance procedures.

Testing and monitoring data to be submitted to the permitting agency will be reviewed by the operator prior to submission. Any data inaccuracies will be noted and checked to determine the error source (e.g. monitoring equipment malfunction, data entry error, lab reporting error, etc.) and correct the error source as soon as possible.

6A.6 Reporting Requirements

This section is provided to satisfy the requirements of 40 CFR 146.90.

The operator shall provide required reports to the permitting agency in an approved electronic format.

Required reports will include the following:

(1) Semi-annual reports

- a. Quarterly carbon dioxide stream characteristics (physical, chemical, other);
- b. Monthly average, maximum, and minimum values for:
 - i. Injection pressure;
 - ii. Flow rate and volume;
 - iii. Annular pressure;
- c. Any event(s) that exceed operating parameters for annular pressure or injection pressure;
- d. Any event(s) which trigger a shut-off device;
- e. Monthly volume and/or mass of carbon dioxide injected over the reporting period;
- f. Cumulative volume of carbon dioxide injected over the project life;
- g. Monthly annulus fluid volume added to the injection well.

(2) Results to be reported within 30 days:

- a. Periodic tests of mechanical integrity;
- b. Any well workover;
- c. Any other test of the injection well performed, if required by the permitting agency.

(3) Information to be reported within 24 hours of occurring:

- a. Any evidence that the carbon dioxide stream or associated pressure front has or may cause endangerment to a USDW;
- b. Any non-compliance with permit condition(s), or malfunction of the injection system, that may cause fluid migration to a USDW;
- c. Any triggering of a shut-off system;
- d. Any failure to maintain mechanical integrity;
- e. Any release of carbon dioxide to the atmosphere.

(4) Notification to be provided at least 30 days in advance:

- a. Any planned well workover;
- b. Any planned stimulation activities (other than stimulation for pre-operation formation testing)
- c. Any other planned test of the injection well.

Records will be retained for at least 10 years following site closure.

SECTION 6B - VERIFICATION WELL MONITORING, INTEGRITY TESTING, AND CONTINGENCY PLAN

6B.1 Fluid Sampling and Analysis

The verification well will be installed only for the purpose of monitoring subsurface conditions and will not be used for injection of CO₂. Therefore, there are no (pre-injection) waste sampling requirements associated with these wells.

6B.1.1 Sampling frequency – N/A

6B.1.2 Analysis parameters – N/A

6B.1.3 Sampling location – N/A

6B.1.4 Detailed waste analysis plan – N/A

6B.2 Monitoring Program

The IL-ICCS project will utilize multiple wells and multiple techniques to monitor the injection zone, zones above the caprock, and also the shallow groundwater. The data from the monitoring program will be used to validate the reservoir modeling used to predict the distribution of the CO₂. An outcome of this research will be to determine which monitoring methods work best for identifying CO₂ within the injection zone so that guidelines or recommendations can be developed for CO₂ monitoring. An important part of the research is to validate that modeling and monitoring techniques are capable of predicting the movement of the CO₂. The United States Department of Energy (US DOE) uses the phrase Monitoring, Verification, and Accounting (MVA) to describe these methods.

One monitoring well (herein referred to as a verification well) will be drilled to observe the location of the CO₂ within the Mt. Simon through direct measurements of pressure and temperature, collection of samples for chemical analysis, and through wireline measurements. This verification well, to be named Verification Well #2, will be drilled vertically and located in a position which is anticipated to be along the outside edge of the CO₂ plume front and at a time of 5 years after injection begins. See Section 5 for the modeling based predictions of the spatial plume front.

The Westbay System will be deployed to allow measurement of fluid pressures and temperature, collection of fluid samples, and performance of standard hydrogeologic tests at and between multiple intervals. Approximately six monitoring zones are planned in this monitoring well; these will be located throughout the Mt. Simon. The exact quantity and location of the monitoring zones will be determined based on drilling and wireline logging information. IBDP results to date will also be used to select the zones within the Mt. Simon to be monitored. A quality assurance (QA) and monitoring program will be utilized to confirm the presence of annular seals between monitoring zones.

After a petrophysical review of all available data, the chosen zones will be developed by perforating short discrete intervals (e.g. 2 to 3 feet each) in the well casing. The Westbay System will be installed inside the well casing, using hydraulically inflated CO₂ resistant packers to seal

the annular space between the perforations and prevent fluid flow between perforations. The Westbay System is compatible with the expected site subsurface environment (brine and CO₂). Elastomers used in the Westbay System will be CO₂ resistant.

Under normal operating conditions continuous monitoring of fluid pressure/temperature will be carried out using the Westbay automated data logging system, which consists of pressure probes located at select monitoring zones; and has the capability of monitoring up to six Monitoring Zones plus one Quality Assurance (QA) Zone (see Section 6B.3) continuously. The actual number of Monitoring Zones and location will be determined during well completion. When operations, such as sampling or logging, require removal of the automated data-logging items, manually operated monitoring can be carried out using wireline deployed probes.

6B.2.1 Recording Devices

Westbay System Description

The Westbay System is comprised of modular tubing, packers and valved port couplings. Fluid samples and in-situ fluid pressures are obtained using a wireline operated electronic probe that is lowered inside the tubing to access the monitoring zones via the valved couplings. Westbay tubing details are discussed in Section 3B.7.3.

The Westbay System packers are made of Stainless Steel and a CO₂-resistant steel-reinforced inflatable sealing element. The packers are inflated singly and independently with water during the Westbay System installation process. The packers remain permanently inflated and sealed during all routine well operations. The packers are individually deflatable.

There are two types of valved couplings in the system: measurement ports and pumping ports. Measurement ports are used where pressure measurements and fluid samples are required. Simultaneous temperature measurements are made while recording pressures at selected measurement ports. Measurement ports incorporate a valve in the wall of the coupling which when opened by a probe provides a direct connection with the formation fluid. When not in operation the measurement port is always closed. This is verified by monitoring the water level inside the Westbay tubing.

Pumping ports are used where the desired volume of fluid injection or fluid withdrawal is larger than would be reasonable through the smaller measurement port valve (such as for purging or for hydraulic conductivity testing of moderate to high hydraulic conductivity zones). Pumping ports incorporate a sliding sleeve which can be moved to expose or cover slots that allow formation fluid to pass through the wall of the coupling. A screen or slotted shroud is normally fastened around the coupling outside the slots. When not in operation the pumping port is always closed. This is verified by monitoring the water level inside the Westbay tubing.

A removable plug may be placed at the bottom of the Westbay tubing string. This plug could then be removed to facilitate circulation or well control during any intervention required in the future.

System Operation

Fluid pressure measurements can be collected from each zone in the verification well. Pressures can be obtained periodically at each selected measurement port using a single pressure probe, or more frequently using a string of probes which remain in the monitoring well so that pressures can be recorded automatically at the well, and accessed periodically either at the well site or via remote communication.

Westbay MOSDAX Pressure Probe

| | |
|--------------------------------------|---------------------|
| Transducer full scale pressure range | 0 psia to 5000 psia |
| Pressure accuracy | ± 0.1% FS |
| (CHRNL) Temperature range | 0°C to 70°C |

The primary purging and well development will be carried out prior to installation of the Westbay System. This purging is performed with an objective to remove fluids introduced into the near wellbore (near the perforated zones) from the drilling operations. Following the installation of the Westbay System well components, a secondary purge with an objective to remove completion fluids will be carried out through the Westbay pumping ports.

The sampling probe incorporates a pressure transducer so fluid pressure measurements can be obtained during each sampling event. Pressure measurements may also be collected from each isolated zone independently of sampling.

Fluid samples can be obtained by lowering a sampling probe and sample container(s) to the desired measurement port coupling. The sampling probe operates in similar fashion to the pressure probe except that a formation brine sample is drawn through the measurement port coupling. Whenever the sampling probe is operated with the sampling valve closed, it functions the same as a pressure probe and supplies the same data.

When using a non-vented sample container, the fluid sample can be maintained at formation pressure while the probe and container are returned to the top of the well. Once recovered, there are a variety of methods of handling the sample:

- the sample may be depressurized and decanted into alternate containers for storage and transport;
- the sample container may be sealed and transported (inside a DOT approved transport container) to a laboratory with the fluid maintained at formation pressure; or
- the sample may be transferred under pressure into alternate pressure containers for storage and transport.

In addition, the security of the well and the Westbay system will be supported throughout sampling activities by incorporating the following procedures:

- Check and record pressure on tubing and bleed down any excess pressure
- Selectively release each pressure probe from its corresponding Westbay port
- Remove pressure probes (using the supplied winch system) from well via wireline and winch, noting and recording fluid level upon removal
- Re-enter tubing with the sampling probe, note and record fluid level upon entry, obtain sample from target zone designated zone

- Remove sampling probe noting and recording fluid level
- Repeat until all samples have been recovered
- Any significant fluid level change (e.g., 100 feet or more) observed during sampling operations will be noted and recorded, and will trigger investigation
- Reinstall pressure probes, note and record fluid levels
- Note final fluid level and include on report. This is the fluid that will be used as a baseline comparison to the next event.

The advantages of this discrete sampling method can be summarized as follows:

- 1) The sample is drawn directly from a measurement port immediately adjacent to the perforations. Therefore, there is no need for pumping a number of well volumes prior to collecting each sample. Because there is no pumping prior to sampling, the sample is obtained with minimal distortion of the natural formation water flow regime.
- 2) The absence of pumping means samples can be obtained quicker, even in relatively low permeability intervals.
- 3) The sample travels only a short distance into the sample container, typically from 1 to 2 ft, regardless of depth.
- 4) The risk and cost of storing and disposing of purge fluids is virtually eliminated.

6B.2.2 Control and Alarm System for the Well Monitoring and Maintenance N/A

6B.2.3 USDW Monitoring in Area of Review See Section 6A.2.3

6B.2.4 Detailed Groundwater Monitoring Plan N/A

6B.2.5 Tracking Extent and Pressure of CO₂ plume See Section 6A.2.5

6B.2.6 Surface Air and and/or Soil gas monitoring See Section 6A.2.6

6B.3 Mechanical Integrity Tests During Service Life of Well

To verify the “absence of significant leaks,” the downhole and surface pressures, along with the casing-tubing annulus pressure, will be monitored and recorded. Routine monitoring activities that will be used as part of the Mechanical Integrity Testing System are described below:

- 1) Monitoring of the pressure or the absence of pressure inside the casing/tubing annulus above the top Westbay System packer will be carried out continuously by means of a pressure gauge at the wellhead. An unexpected change in the annulus pressure will be investigated to ensure that it is not an indication of the loss of a top packer seal. See Section 3B.7.5.6.

Also, see Section 6B.4 for step-by-step procedures regarding installation and removal of the Westbay pressure monitoring system.

- a. Under normal operating conditions, monitoring of the pressure inside the Westbay System tubing will be carried out continuously using a pressure gauge at the wellhead. Manual readings of the fluid level inside the Westbay System will be collected as part of standard operating procedures for all other activities (tubing open to atmosphere). An unexpected change in the water level inside the Westbay System tubing will be investigated to confirm that it is not indication of a loss of hydraulic integrity of the Westbay System tubing.
 - b. Once a static fluid level is established, it would not be expected to have any significant changes from one sampling event to the next. At each event, the depth to the static water level will be measured and if it has changed by more than 100 feet, an investigation will be triggered.
- 2) Continuous measurement and recording of fluid pressure/temperature will be carried out using the Westbay automated data logging system, which consists of pressure probes and temperature sensors located at select monitoring zones. Automated measurement of fluid pressure and temperature is intended from each of the perforated monitoring zones. Observed differential pressures between perforated zones provide on-going confirmation of effective annular seals between monitoring zones. As part of the Mechanical Integrity Testing System, an additional pressure probe will be used to continuously measure and record fluid pressure in the Quality Assurance (QA) zone located adjacent to the Eau Claire shale. (The QA Zone consists of two packers and the blank (not perforated) casing between them. Having no connection to the formation, pressure data from the QA zone can be used to document the continued sealing performance of the packers).

Continuous fluid pressure measurements from the QA zone during and after CO₂ injection will be compared to background data trends and the persistent presence of a pressure difference (corrected for depth and fluid density) between the QA Zone and the adjacent perforated zone. An unexpected decrease of this corrected pressure difference to less than 10 psi will be investigated to confirm that it is not an indication of a possible loss of packer seal. The value of 10 psi was selected based on the accuracy specification of the Westbay MOSDAX pressure probe as given in Section 6B.2.1.

- 3) The automated data logging system may be removed at regular intervals for maintenance and servicing, as well as for any other planned activities such as sampling. As part of standard Westbay System operating procedures, fluid pressure and temperature will be measured manually from all monitoring zones following removal of the automated system, and before replacement of the automated system. Should the system be removed longer than 4 weeks, manual pressures in the QA zone will be taken in the following 2 weeks and every 6 weeks thereafter until the system is reinstalled. The pressure/temperature measurements will be compared to background data and other previous profiles. The upper annulus system will be monitored (data will go back to ADM control room.)
- 4) Baseline cased-hole logs will be run prior to injection and can be run on a repeat basis if conditions warrant. The profile inside of the Westbay tubing will allow passage of cased hole logging tools [e.g. Temperature, Pulse Neutron Capture (PNC), also known as Sigma or

RST]. In the event of a compromised seal where CO₂ enters the annulus, the PNC tool will be used to identify unexpected CO₂ independently of Westbay System measurements.

In the event that the routine monitoring activities detailed above are inconclusive, a range of additional test procedures could be employed to further investigate any data irregularities and if necessary determine an appropriate remedial action. If in-place remediation cannot be carried out, the Westbay System can be removed. Procedures for Westbay System removal are outlined elsewhere in this permit application. (Section 6B.4 Contingency Plan)

Temperature Logging and Time Lapsed Formation Sigma Logs

To verify the “absence of significant fluid movement,” time-lapse formation sigma logs can be run and data recorded across the entire interval from the deepest reachable point in the Mt. Simon to, at a minimum, the Maquoketa Formation (the lowest alternative confining zone). The initial sigma log will include temperature data and will be run before CO₂ injection to establish a pre- CO₂ baseline to compare with the post injection logging runs. Logs will be run under static conditions, presumably with tubing in the well, although valid data can and will be acquired should tubing be pulled for any unforeseen reasons. If any subsequent surveys are performed during the CO₂ injection period, the evaluation shall also include a temperature log to further detect fluid movement. The temperature log shall be run over the same intervals and at the same conditions as the sigma logs. Should either evaluation method (sigma or temperature log) detect significant fluid movement above the seal, oxygen activation logging methods may be used to further quantify the flow and aid in establishing a remediation plan. Details of Schlumberger’s version of these tools are described below:

Pulsed Neutron Capture Logging

Reservoir Saturation Tool (RST) - Designed for reservoir complexity

Within the last decade, nearly every aspect of reservoir management has grown in complexity. What once was the exception is now routine: multiple-tubing and gravel pack completions, secondary and tertiary recovery, highly deviated wellbores, and three-phase production environments. The RSTPro* Reservoir Saturation Tool helps manage complexity by delivering reliable, accurate data. Run on the PS Platform string, with its suite of cased hole reservoir evaluation and production logging services, the RSTPro* tool uses pulsed neutron techniques to determine reservoir saturation, lithology, porosity, and borehole fluid profiles. This information is used to identify bypassed hydrocarbons, evaluate and monitor reserves in mixed salinity and gas environments, perform formation evaluation behind casing, and diagnose three-phase flow independently of well deviation.

An electronic generator in the RSTPro* tool emits high-energy (14-meV) neutrons in precisely controlled bursts. A neutron interacts with surrounding nuclei, losing energy until it is captured. In many of these interactions, the nucleus emits one or more gamma rays of characteristic energy, which are detected in the tool by two high-efficiency scintillators. High-speed digital signal electronics process and record both the gamma ray energy and its time of arrival relative to the start of the neutron burst. Exclusive spectral analysis algorithms transform the gamma ray energy and time data into concentrations of elements (relative elemental yields).

Formation sigma, porosity, and borehole salinity

In sigma mode, the RSTPro* tool measures formation sigma, porosity, and borehole salinity using an optimized Dual-Burst* thermal decay time sequence. The two principal applications of this measurement are saturation evaluation, which relies on measurement accuracy, and time-lapse monitoring, where sensitivity is determined by measurement repeatability. A higher degree of accuracy in the formation sigma measurement is achieved by combining high-fidelity environmental correction with an extensive laboratory characterization database. The accuracy of RSTPro formation sigma is 0.22 cu for characterized environments and has been verified in the Callisto and American Petroleum Institute industry-standard formations. Formation porosity and borehole salinity are either computed in the same pass or input by the user. Exceptional measurement repeatability makes the RSTPro tool more sensitive to minute changes in reservoir saturation during time-lapse monitoring. The gains in repeatability and tool stability are the result of higher neutron output and sensor regulation loops. At the typical logging speed of 900 ft/hr [275 m/hr] for time-lapse monitoring, RSTPro repeatability is 0.21 cu.

Water velocity (Oxygen activation logging)

The RSTPro WFL* Water Flow Log measures water velocity by using the principle of oxygen activation. Gamma ray energy discrimination and tool shielding reduce the background from stationary activation, improving sensitivity in low-signal environments such as flow behind casing.

The cased-hole logging tools (e.g. the Reservoir Saturation Tool – RST) can pass through the Westbay tubing which has an internal diameter of 2.26”, and log the near-wellbore environment behind the well casing. The cased-hole logs are not adversely affected by the Westbay System such that the tubing does not need to be removed during the RST and other cased-hole wireline logging techniques. The running of the cased hole logging tools will require the removal of the Westbay automated data logging system.

6B.3.1 Continuous Monitoring of Annular Pressure

Continuous annular pressure monitoring will also be used to verify mechanical integrity of the well. The pressure data will be transmitted to the ADM control room for monitoring and will be recorded at the same frequency as the injection well data (frequency) and reported monthly. If a pressure increase greater than 100 psi over atmospheric pressure is observed, or if pressure drops below 95% of atmospheric pressure (i.e. < 14.0 psi), an alarm will be triggered and the cause will be investigated. Specifications for the pressure gauge are included on Figure 6. The annular space will also be checked quarterly to verify that the annulus is full; fluid will be replaced as needed. This observation will be noted in the operating report. Pressure fluctuations in the range (or possibly exceeding the range) noted above are likely to occur immediately following well construction, sampling, and well workovers but would not be indicative of well integrity issues. Notation of these events will be included in the monthly reports. In the event of a power outage, manual readings will be taken and recorded.

In addition the following section describes the mechanical integrity testing of the wellbore across the multi-level monitoring system.

The Westbay System is designed to incorporate a high degree of quality assurance testing and verification to confirm mechanical integrity of the system and the presence of packer seals between monitoring zones

Monitoring is intended to be carried out at multiple levels within and above the Mt. Simon injection horizon. A quality assurance (QA) and monitoring program will be utilized to confirm the presence of annular seals above the uppermost monitoring zone, and particularly to document the performance of the annular seals which isolate the individual zones and also prevent the movement of fluids into the overlying stratigraphic units.

The Westbay System is compatible with the expected site subsurface environment (brine and CO₂) and elastomers present in the System will be CO₂ resistant. Thus, loss of mechanical integrity or component failure leading to the potential for vertical migration of fluid in the annulus is not expected. However, a number of methods, including wireline and pressure and temperature measurements, will be used to monitor system integrity and to verify the absence of vertical fluid movement within the well. These methods are implemented during Westbay System installation and during ongoing monitoring well operations, as described below.

During the installation process, a thorough QA procedure is followed to document Westbay System performance, including:

- testing the hydraulic integrity of each tubing joint as the tubing string is assembled, providing baseline data confirming that the assembled joint is sealed and not a pathway for vertical movement of formation fluids
- testing the hydraulic integrity of the entire Westbay System tubing once the tubing has been lowered into place, again providing baseline data confirming that the tubing string is sealed and not a pathway for vertical movement of formation fluids
- testing and documenting the proper operation of each of the measurement ports (the ports used for pressure monitoring and sampling) by carrying out a pre-inflation pressure profile
- documentation of inflation performance of each packer as it is independently and individually inflated with fresh water (the inflation pressure and volume is measured and recorded, and the correct function of each packer is documented)

After the packers have been inflated and seals have been established between the perforated zones, fluid pressure profiles and cased-hole logging will be carried out to establish baseline conditions of the well.

Fluid pressure profiles are carried out using a wireline operated pressure probe with transducer. The annular fluid pressure is measured at each measurement port (for measuring fluid pressure and/or collecting of fluid samples). A measurement port will be adjacent to each packer in the Westbay System installation. Thus, fluid pressures can be measured and recorded in each perforated zone, as well as in each of the shut-in (cased) sections of the installation between each perforated zone.

A blank zone above the perforations is referred to as a QA Zone. A QA Zone consists of two packers and the blank (not perforated) casing between them. Having no connection to the formation, pressure data from such zones can be used to document the continued sealing performance of the packers. The presence of a persistent measurable pressure difference across a packer indicates the presence of a positive annular seal.

The pressure data collected from all of the perforated zones and the QA zone will be used to provide baseline data, and will be compared to the pre-inflation profiles to help document the presence of seals between perforations in the annular space. Preliminary testing in the QA zone will also provide baseline data.

Evaluation of baseline pressure data collected from the Westbay System during the pre-injection period will be an integral part of establishing baseline parameters to be considered as undisturbed behavior. Subsequent data will be compared to baseline data to identify readings or trends which are exceptions to the expected baseline behaviors. Thus, once established, baseline data of fluid pressure profiles and cased-hole logs will be compared to data from routine Westbay System monitoring activities to monitor/verify mechanical integrity of the system and ongoing presence of annular seals.

The Westbay System will be used for automated data logging of fluid pressure/temperature from select monitoring zones, as well as manual collection of fluid samples, measurement of fluid pressure/temperature and testing. Manual operations require removal of the automated data logging items.

6B.3.2 Annual Testing

The annulus between the long string and the Westbay tubing above the uppermost packer will be pressure tested to 300 psi for one hour with a maximum of 3% leakoff allowed (see procedure in Section 3B.7.5). This test will be performed at least once per year and results will be reported in the next operating report. Following the annual test, the remaining pressure will be bled off to atmospheric and the annular space will be shut in.

6B.3.3 Ambient Pressure Monitoring

Continuous measurement and recording of fluid pressure/temperature will be carried out using the Westbay automated data logging system, which consists of pressure probes located at select monitoring zones. Automated measurement of fluid pressure is intended from each of the perforated monitoring zones. It should also be noted that the observed differential pressures between perforated zones will provide an ongoing confirmation of effective annular seals between monitoring zones. As part of the Mechanical Integrity Testing System, an additional pressure probe will be used to continuously measure and record fluid pressure in the QA zone located adjacent to the Eau Claire shale. Continuous fluid pressure measurements from the QA zone during and after CO₂ injection will be compared to background data trends and the persistent presence of a pressure difference (corrected for depth and fluid density) between the QA Zone and the adjacent perforated zone. An unexpected decrease of this corrected pressure difference to less than 10 psi will be investigated to confirm that it is not an indication of a

possible loss of packer seal. The value of 10 psi was selected based on the accuracy specification of the Westbay MOSDAX pressure probe as given in Section 6B.2.1.

6B.3.4 Corrosion Monitoring Plan

Cased hole logs (Multi-finger caliper, Ultrasonic Cement Evaluation) will be run during the initial verification well completion to provide baseline measurements of the long string casing internal diameter and thickness. This will allow for a comparison to subsequent logs if conditions suggest a need to re-run logs.

6B.4 Contingency Plan for Well Failure or Shut In

If necessary, the tubing string can be retrieved from the well. While this may not be the first course of action in response to information from the integrity monitoring measurements, this option is available if required.

The verification well will be remediated under the following conditions:

- 1) Abnormal annular pressure readings are observed.

Following the MIT, the remaining pressure will be bled off to atmospheric and the annular space will be shut in. If a pressure increase greater than 100 psi over atmospheric pressure is observed, or if pressure drops below 95% of atmospheric pressure (i.e. < 14.0 psi), an alarm will be triggered and the cause will be investigated.

- 2) Abnormal pressure / water levels are observed inside the tubing.

If there are pressures measured 100 psi over static levels or if pressure drops below 95% of atmospheric pressure (i.e. < 14 psi) inside the tubing an alarm will be triggered. Further investigation will be conducted as to the cause of the abnormal pressure reading, and remediation planned.

- 3) Abnormal pressure readings in the downhole blank QA zone.

On-going fluid pressure measurements from the QA zone during and after CO₂ injection will be compared to background data trends and the persistent presence of a pressure difference (corrected for depth and fluid density) between the QA Zone and the adjacent perforated zone. If an unexpected decrease of corrected pressure difference has been identified (see Section 6B.3 and 6B.3.3) a packer leak will be suspected. Further investigation will be conducted as to the cause of the abnormal pressure readings. Remediation will occur if the investigation points to a failure which would allow upward fluid migration past the upper boundary of the Eau Claire seal.

- 4) Suspicion that the well integrity has been compromised.

- 5) Surface equipment has been damaged.

If any of above should occur, steps will be taken to identify and correct any equipment deficiencies. Many interventions can be carried out using the Westbay wireline system to affect repairs and re-establish well bore integrity. Only if none of these interventions were successful then plans to remove the Westbay monitor system from the well would be put in place. If required, retrieval of the tubing string would be done with BOPs in place according to the following summarized procedure:

- 1) Secure well until a workover rig and support equipment can be mobilized. Notify permitting agency of planned workover.
- 2) Rig up workover rig with pump and tank. Bleed down any pressure. Fill both tubing and annulus with kill weight fluid.
- 3) Go in hole with Westbay wireline assembly and release top packer. Open pumping port and attempt to circulate fluid at very low rate. Close pumping port and proceed to next packer.
- 4) When all packers are released and relaxed, pull plug (if a plug was placed in bottom of Westbay string) and attempt to slowly circulate the well with kill weight fluid.
- 5) Prepare to remove tubing string from the well while carefully keeping the hole full of kill-weight brine. Pull tubing slowly as to not over-pull the designed strength of the tubing.
- 6) Remove tubing from the well and examine to identify the cause of the anomalous pressure.

Upon removal, a decision will be made as to whether to repair and replace or to plug and abandon the well.

The plan for the verification well includes but is not limited to the following:

- 1) A modified master and single wing wellhead assembly. Since these wells are not injection wells, wing valves will not have an automatic shut-down system but will employ manual gate valve assemblies which will be closed during normal operations.
- 2) All annuli will have pressure gauges installed. Gauges to be 0 to 150 psi operating range.
- 3) Under normal operating conditions, the well is essentially shut in and will be open only for testing, sampling, and maintenance. See Figure 3B-4 for wellhead diagram.

In the event of a power outage, manual readings of the pressure in the tubing and annulus will be taken and recorded every four hours until power is restored. Note that in the event of a power outage, the injection well will be shut in.

6B.4.1 *Persons Designated to Oversee Well Operations*

A site-specific list of persons designated to oversee well operations in the event of an emergency shall be developed and maintained during the life of the project.

6B.5 Quality Assurance Plan See Section 6A.5

6B.6 Reporting Requirements See Section 6A.6

SECTION 7 - CHARACTERISTICS, COMPATIBILITY AND PRE-INJECTION TREATMENT OF INJECTED FLUID

7.1 Component Streams Forming Injection Fluid

CO₂ from Biofuel Fermentation process

7.2 Source and Generation Rate of Component Streams

The CO₂ source is the ADM biofuel fermentation process, which produces approximately 3,000 metric tonnes per day (MT/day) of CO₂ at a 1,000,000 gallon ethanol per day production rate. The facility equipment is designed to compress and inject a maximum of 3,300 MT/day

7.3 Volume of Injection Fluid Generated Daily and Annually

The target injection rate will initially be 2,000 MT/day; after the nearby IBDP project concludes its injection phase in 2014, an additional 1,000 MT/day will be diverted to the proposed injection well, for a target injection rate of 3,000 MT/day, or approximately 1.0 million tons annually. The total injection volume is targeted at approximately 4.75 million tons of CO₂ over the 5-year injection phase of the ICCS project.

A mass flow meter will be installed after compression and dehydration, but prior to well head. The meter will produce a direct reading of CO₂ being injected reporting in units of total mass per unit time.

7.4 Physical and Chemical Characteristics of Injection Fluid

The values provided below are based on wellhead pressure and temperature conditions of 2,380 psig and 120°F, respectively. Characteristics of the injection fluid could vary significantly at different locations in the compression and dehydration process and seasonally with changes in ambient temperature. The maximum injection pressure will be 2,380 psi and the actual injection pressure at the wellhead may be lower.

7.4.1 *Generic Fluid Name*

Carbon Dioxide (CO₂)

7.4.2 *Fluid Phase*

Supercritical and/or dense phase

7.4.3 Complete Injection Fluid Analysis

Typical Analysis of Feed Stream (Some Variation is Possible Due to Site-to-Site and Day-to-Day Conditions):

| Component | Concentration (mol. %) |
|--------------------|------------------------|
| CO ₂ | 99+ |
| Total Hydrocarbons | 0.01200 |
| N ₂ | 0.01100 |
| H ₂ S | 0.00079 |
| O ₂ | 0.00070 |

Sample was collected after water scrubber, before CO₂ plant.
Approximate pressure is 14.5 psia

7.4.4 *Flash Point* N/A

7.4.5 *Organics*

0.0127 mol. % (based on a typical analysis of the feed stream). Some variation is possible due to site-to-site and day-to-day conditions.

7.4.6 *TDS* N/A

7.4.7 *pH* N/A

7.4.8 *Temperature*

Approximate temperature is 80°F-120°F

7.4.9 *Density*

44.3 lbs/cf [at 2,200 psig, 120°F]

7.4.10 *Specific Gravity*

0.71 Specific gravity [at 2,200 psig, 120°F] (liquid water = 1.0)

7.4.11 *Compressibility*

$C_{CO_2} = 0.00045 \text{ (psi)}^{-1}$ [at 2,200 psig, 120°F]

7.4.12 *Micro Organisms* N/A

7.4.13 *Chemical Persistence*

Not applicable. Although CO₂ may exist indefinitely in the environment without being destroyed by natural processes, it does not bioaccumulate with potential long-term toxic effects.

EPA definition of persistence: “A chemical's persistence refers to the length of time the chemical can exist in the environment before being destroyed by natural processes.”

[Reference: <http://www.epa.gov/fedrgstr/EPA-TRI/1999/January/Day-05/tri34835.htm>]

7.4.14 Key Component Name(s)

Carbon Dioxide (CO₂)

7.5 Injection Fluid Compatibility

7.5.1 Compatibility with Injection Zone

No compatibility problems are anticipated in the injection zone. Geochemical modeling was used to predict the effects of injecting supercritical CO₂ into a model Mt. Simon sandstone (Berger et al., 2009). Based on chemical and mineralogical data from the Manlove Gas Storage Field in Illinois, the geochemical modeling software package, Geochemist's Workbench (Bethke, 2006), was used to simulate geochemical reactions. As expected, the injected CO₂ decreased the pH of the formation brine to about pH 4.5. As the reaction was allowed to progress, the pH of the formation brine increased to pH 5.4.

7.5.2 Compatibility with Minerals in the Injection Zone

In the geochemical simulations mentioned in above, Berger et al. (2009), it was predicted that illite and glauconite dissolved initially. As the reaction was allowed to proceed, kaolinite and smectite were predicted to precipitate. It was predicted that the volume of pore space would not be significantly altered (Berger et al., 2009). Therefore, no compatibility problems, such as a major reduction in injection-formation permeability resulting from chemical precipitates, are expected.

7.5.3 Compatibility with Minerals in the Confining Zone

In the geochemical simulations mentioned above, Geochemist's Workbench predicted that as the CO₂ reacts with the Eau Claire formation, illite and smectite would initially dissolve, but that the dissolved CO₂ could be precipitated as carbonates (Berger et al., 2009). This dissolution and precipitation process is not expected to affect the caprock integrity.

7.5.4 Compatibility with Injection Well Components

The subsurface and surface designs exceed minimum requirements to sustain system integrity to ensure CO₂ remains in the Mt. Simon. For reasons such as equipment or supply availability, or changes to the supplemental monitoring program, the final well design may vary but will meet or exceed these requirements in terms of strength and CO₂ compatibility.

7.5.4.1 Injection Tubing

As the CO₂ will be dehydrated to less than 30 lb H₂O/MMSCF or 630 ppm v of H₂O, the expected reactivity with the tubing will be negligible. Nevertheless, the injection tubing will be

composed of chrome steel (e.g., 13Cr) and is specifically engineered to function in environments with high concentrations of CO₂.

No chemical deterioration is expected; however, normal well intervention (e.g. possible coupling leak or pin-hole leak) where the well will have to be monitored and repaired (worked over) may be periodically required. The string of injection tubing should pose no adverse chemical reaction or degradation of the injection string from the injection fluid (supercritical state CO₂). Periodic tubing calipers will be run and compared to the original baseline caliper to monitor tubing pitting or any other injection string degradation. The tubing selection is expected to improve operations by decreasing the frequency of well workovers requiring tubing replacement and repair.

7.5.4.2 Long String Casing

The long string casing to be installed from total depth of the well past the base of the confining layer (from total depth to approximately 5,000 feet) will be composed of chrome steel (e.g., 13Cr80) and specifically engineered to function in environments with high concentrations of CO₂. The long string casing in the remainder of the well (5,000 feet to surface) will be carbon steel. This section of casing, however, will remain isolated from the injected CO₂ due to the tubing-annulus protection system and the protective cement sheath in which it is encased. Reactivity between the injected CO₂ and the long string casing is expected to be negligible.

The proposed long string casing (9 ⁵/₈-inch diameter) will be cemented from the bottom of the drilled hole into the intermediate casing and on up to surface, thus reducing any potential brine and CO₂ moving in the annular area between the drilled hole and casing. This long string will be cemented with special CO₂ resistant cement which should decrease the risk of channeling behind pipe. The most affected section of the long string casing is perceived to be that which is below the packer and End of Tubing (EOT). This is the section of casing that will be subjected to the CO₂ directly while it is being injected into the desired zone of the Mt Simon. To minimize any potential risk of chemical degradation, casing caliper logs can be run (baseline first, then at any time going forward when the injection tubing is removed from the well) to determine any adverse effects on the deterioration of the long string casing wall thickness. The supercritical state of the CO₂ with the absence of oxygen at depth should minimize any adverse affect, but this will in part be dependent on how long and to what extent the volume of CO₂ can be continuously injected. Moreover, the CO₂ will be dehydrated at the surface to minimize reaction with water and thus minimizing the creation of carbonic acid which could potentially corrode the casing below the packer.

7.5.4.3 CO₂ Resistant Cement

The long string casing will be encased from total depth to approximately 4,800 feet (or approximately 500 feet into the intermediate casing string) in Schlumberger's proprietary blend of CO₂ resistant cement, EverCRETE. Technical descriptions of the cement properties can be found in Appendix B. Reactivity between the injected CO₂ and the cement is expected to be negligible.

The CO₂ resistant cement that will be used for the injection interval has been engineered to be more resistant to degradation by wet CO₂ and carbonic acid than traditional Portland cement-

based well cement. The primary improvement in the CO₂ resistant cement over traditional Portland cement is the reduction in volume of the lime and water in the set cement. The increased compatibility of the CO₂ and the CO₂ resistant cement compared to CO₂ and Portland cement is described below:

- The CO₂ resistant cement has very low Portland cement content in the set cement volume. Portland cement is the main component that goes through the carbonation process. By reducing its content, the durability of CO₂ resistant cement is significantly enhanced. Despite a low Portland cement content, high compressive strength is achieved (above 2,000 psi) over a wide density range (12.5 ppg - 16 ppg). Even though this system has a small amount of Portland cement, it does go through the carbonation process, but it is self-limiting and prevents further leaching.
- The CO₂ cement system is designed with an optimized particle size distribution (PSD). Consequently, the CO₂ resistant cement has very high solids content, i.e. water content is reduced significantly, compared to a conventional cement system. Low water content significantly reduces the permeability of the set cement matrix and strongly reduces the cement degradation rate due to CO₂ reaction.
- The CO₂ resistant cement is a lime (Ca(OH)₂) “free” system compared to conventional Portland cement; for example, a neat 15.8 ppg set cement has about 13% “free” lime content. The reaction between CO₂ and cement is primarily due to the presence of free lime. The rate of the reaction and the amount of calcite formed from the reaction is dependent on the amount of free lime present. This reaction creates porosity in the cement. Eventually, the CO₂ and water mix to form carbonic acid which will dissolve the calcite, which further increases the porosity of the cement.
- The dissolution of calcite degrades the mechanical properties of the Portland cement. For longer CO₂ exposure, Portland cement integrity is reduced by the dissolution of calcite under acidic conditions. By having a lime-free cement system, the resistance of the cement to degradation in a CO₂ environment is effectively increased compared to a conventional Portland cement system.

Appendix B has the complete manufacturer’s specifications for the EverCRETE product.

7.5.4.4 Annular Fluid

The annular fluid (packer fluid) between the injection tubing and the long string casing will be a 10.5 ppg brine with corrosion inhibitor additive that is compatible with the injected CO₂ and will minimize corrosion to the tubing and casing. Reactivity between the injected CO₂ and the annular fluid is expected to be negligible.

The weight of the packer fluid will be controlled to have enough hydrostatic weight to easily kill the well (expected formation gradient pressure in the Mt Simon at depth is anticipated to be approximately 0.455 psi/ft) when well intervention has to occur during any time of the life cycle of the well.

There is no risk of unexpected reactions with the annular fluid and the injection fluid that will breach the injection casing. The packer fluid is compatible with injected CO₂ and will minimize

corrosion of the injection casing and tubing. The worst reaction case would be a slow, almost immeasurable mass of CO₂ entering the annulus and lowering the pH of the annular fluid in the vicinity of the tubing leak. However, while the mass may be very low, the leak would be detected by the change in the annular surface pressure monitoring equipment almost immediately and injection would cease. Any leak would require that the tubing string be pulled and repaired and the annular fluid would be replaced with a fresh packer fluid.

7.5.4.5 Packer(s)

The packer design calls for a Schlumberger Quantum Max Type III Seal-bore Assembly packer composed of chrome steel (13Cr). The sealing elements of the packer and seal-bore assembly are comprised of nitrile rubber which is designed to be durable in environments with high CO₂ concentration. As a result, reactivity between the injected CO₂ and the injection packer is expected to be negligible.

The packer and the amount of weight that will be set on top of it will be designed to account for the buckling and all other forces that will be exerted during the injectivity phases, thus ensuring integrity of the annulus.

The packer will have a CO₂ compatible elastomer. The dry CO₂ should not react with the steel components of the packer. The tubing and packer will be compatible with CO₂: the elastomer packer element will be selected to resist CO₂ and the packer body will be made of chrome steel. No “blanket” of diesel or kerosene or similar non-reactive fluid will be placed below the packer. CO₂ is less dense than water and is less dense or very similar in density to many hydrocarbon liquids like diesel and kerosene. It is highly unlikely that these types of fluids (diesel or kerosene) would ever remain in place under the packer in a CO₂ injection scenario.

7.5.4.6 Well Head Equipment

Components of the wellhead equipment expected to be in contact with the injected CO₂ are proposed to be constructed from schedule 310 and 410 stainless steel; therefore, no adverse reactions are expected between the injected CO₂ and any the wellhead components.

At present the wellhead assembly will consist of Section A & B, then a Xmas tree assembly made up of a minimum, 2-SS master valves (a swab valve and another a master) with a 3,000 psig wing valve outfitted with an automatic shut down device, all being stainless steel (Xmas tree & upper assembly). This will allow for the installation of blowout preventors with minimal intervention if any workover activity is required during the life of the well. The dry CO₂ should not react with the steel components of the wellhead; stainless steel is proposed to further minimize any possibility of CO₂ reacting with bare steel.

7.5.4.7 Holding Tanks(s) and Flow Lines

There will be no holding tanks for the injection fluid. Consequently, there are no CO₂ holding tank compatibility concerns.

The flow lines from the injection fluid source to the injection site are expected to be 8-inch diameter schedule 120 carbon steel pipe. (The pipe diameter and material selection will be determined after the injection rate and pressure are finalized.) As a result of the cooling, dehydration and compression, the CO₂ will be relatively dry or free of water. Dry CO₂ is compatible with carbon steel pipe. The design basis for the surface facility gas dehydration unit is to reduce the water content of the CO₂ to a range of 7 to 30 lb of H₂O/MMSCF (150 to 630 ppmv H₂O). This water content range is consistent with typical U.S. CO₂ transmission pipeline water content specifications for carbon steel pipe. There are no compatibility concerns between the CO₂ and the flow lines between the compressor and the wellhead.

7.5.5 Compatibility with Filter and Filter Components

There are no plans to filter the CO₂ prior to injection. Consequently, there are no compatibility concerns between the CO₂ and filters and filter components. The CO₂ from the fermentation process and subsequently, compressed and cooled will not have any particulates entrained in the CO₂ stream. As such there are no filters or filtering components.

7.5.6 Full Description of Compatibility Concerns

At this time there are no compatibility concerns with the injection zone, minerals in the injection zone, and minerals in the confining zone. The CO₂ is expected to have negligible to no reaction with the minerals and formation water. Any reactions that may occur are not expected to affect the containment of the CO₂ below the primary seal. There are compatibility issues with regards to CO₂ if water is present. Components to the injection wellhead and wellbore will be selected to minimize and negate any reaction with the CO₂. Any elastomers used will be selected based on contact with CO₂. Additional details on the corrosion monitoring plan are included in Sections 6A.4 and 6B.4.

7.5.7 Pre-Injection Fluid Treatment

Other than dehydration, there will be no pre-injection fluid treatment of the injection fluid (CO₂) at the well site.

7.6 References

Bethke, C.M.. 2006. *The Geochemist's Workbench (Release 6.0) Reference Manual*. RockWare, Inc., Golden CO, 240 p.

Berger, P.M., Mehnert, E., and Roy, W.R. (2009) Geochemical Modeling of Carbon Sequestration in the Mt. Simon Sandstone. Geological Society of America, *Abstracts with Programs*, vol. 41, no. 4, p. 4.

SECTION 8A - INJECTION WELL PLUGGING & ABANDONMENT PROCEDURES

This section is provided to satisfy the requirements of 40 CFR 146.92.

8A.1 Description of Plugging Procedures

Upon completion of the project, or at the end of the life of the CCS #2 injection well, the well will be plugged and abandoned to meet all applicable requirements. The need to abandon the well prior to any injection (i.e. during construction) is also a possibility. The plug procedure and materials will be designed to prevent any unwanted fluid movement and to protect any USDWs. The well plugging procedure and design will be updated in the well plugging plan based on any new information gained during well construction and testing. The final plugging plan will be developed after collaboration and interaction with the UIC Program Director; however, to fulfill permit requirements, we propose the preliminary plan which follows.

8A.1.1 Abandonment during Construction

Abandonment during well construction, while sections of the wellbore are uncased could take place while: (1) drilling the surface hole (≤ 350 ft), (2) drilling intermediate hole ($\leq 5,300$ ft), or (3) drilling long-String hole ($\leq 7,500$ ft).

During each scenario, the drill string (drill collars, drill pipe, and drill bit) represents the most likely risk for losing and leaving equipment in the hole. Although unlikely, it is possible that logging tools, a core barrel, or other piece of equipment can get stuck and be left in the hole. Every attempt will be made to recover all portions of the string or other equipment prior to abandonment.

If equipment cannot be retrieved and must be abandoned in the wellbore, no unique plugging procedure should be required and the plugs will be placed as specified in the plugging plan. Plug placement will depend upon depth of the hole, the geology and the depth that the equipment was lost in the well. If the well has not penetrated or is not within 100 feet of the caprock, then typically plugging during construction would require placing plugs across any zones capable of producing fluid and at the previous casing shoe. A surface plug will be set and the well filled with drilling mud between the plugs. If the caprock has been penetrated when the well is judged to be lost, the well will be plugged using CO₂-resistant cement from TD to 1,000 feet above the caprock seal using the balanced plug method. This may require setting multiple plugs. If this occurs, each plug will be verified before moving to the next.

If a radioactive logging source is lost in the hole (e.g. a density and/ or neutron porosity logging source), current Nuclear Regulatory Commission (NRC) regulations will be followed. A 300-foot red cement plug will be placed immediately above the lost logging tool. An angled kick-plate will be placed above this plug to divert any subsequent drilling that may coincidentally enter this wellbore. Current NRC regulations require that the surface casing remain extended above the ground surface with an informative ground plate welded to the pipe. The plate includes information to identify what is in the hole. Depending upon where in the well the radioactive source is lost, plugging above the kick-plate will proceed as described above.

Plug Placement Method: The method for placing the plugs in CCS #2 will be the “Balanced Plug” method. This is a basic plug spotting process that is generally considered more efficient and is consistent with best industry practices.

8A.1.2 Abandonment after Injection

After injection has ceased, the well will be flushed with a kill weight brine fluid. A minimum of three tubing volumes will be injected without exceeding fracture pressure. Bottom hole pressure measurements will be made and the well will be logged to ensure mechanical integrity outside the casing prior to plugging. If a loss of mechanical integrity is discovered, it will be repaired using the squeeze cementing method prior to proceeding with the plugging operations. Detailed plugging procedure is provided in Section 8A.1.4 below. All casing in this well will be cemented to surface and will not be retrievable at abandonment. After injection, the injection tubing and packer will be removed. If the tubing and packer cannot be released, an electric line with tubing cutter will be used to cut off the tubing above the packer and the packer will be left in the well. After the tubing and packer are removed, the balanced-plug placement method will be used to plug the well. If the tubing has to be cut and the packer left in the well, the cement retainer method will be used for plugging the injection formation below the abandoned packer.

8A.1.3 Type and Quantity of Plugging Materials, Depth Intervals

The volume and depth of the plug or plugs will depend on the final geology and downhole conditions of the well as assessed during construction. Well cementing software (e.g. Schlumberger’s CemCade) will be used to model the plugging and aid in the plug design. The cements used for plugging will be tested in the lab prior to plug placement and both wet and dry samples of each plug will be collected during plugging to ensure quality of the plug.

All of the casing strings will be cut off at least 3 feet below the surface, below the plow line. A blanking plate with the required permit information will be welded to the top of the cutoff casing.

8A.1.4 Detailed Plugging and Abandonment Plan

8A.1.4.1 Notifications, Permits, and Inspections (Prior to Workover or Rig Movement).

Notifications, permits, and inspections are the same for plugging and abandonment during construction or post-injection. The procedure is:

- 1) Notify the regulatory agency at least 60 days prior to commencing plugging operations. (Note that this timeline will not apply for plugging and abandonment during well construction.) Provide updated plugging plan, if applicable. Ensure proper notifications have been given to all regulatory agencies for rig move.
- 2) Ensure that the plugging procedure has been reviewed and agreed upon by regulatory agency.
- 3) Ensure that the following steps are performed prior to well plugging:
 - a. The injection well is flushed with a buffer fluid;
 - b. The bottomhole reservoir pressure will be measured;

- c. A final external mechanical integrity test will be completed.
 - d. Plugging procedure has been reviewed and agreed upon by regulatory agency.
- 4) Ensure in advance that a pre-site inspection has been performed and the rig company has visited the site and is capable of transporting rig, tanks & ancillary equipment to perform P&A operations. Notify all key third parties of expected work scope, and ensure third party contracts for work are in place prior to move in.
 - 5) Have copies of all government permits prior to initiating operations and maintain on location at all times. Check to see if conditions of approval have been met.
 - 6) Make sure partners (U.S. DOE, EPA and ADM) approvals have been obtained, as applicable.

A site-specific list of facility contacts will be developed and maintained during the life of the project.

8A.1.4.2 Volume Calculations

Volumes will be calculated for specific abandonment wellbore environment based on desired plug diameter and length required. Volume calculations are the same for plug and abandonment during construction and post-injection.

- 1) Identify the following based on the geology and hole conditions:
 - a. Length of the cement plug required.
 - b. required setting depth of base of plug.
 - c. Volume of spacer to be pumped ahead of the slurry.
- 2) Determine the following:
 - a. Number of sacks of cement required.
 - b. Volume of spacer to be pumped behind the slurry to balance the plug.
 - c. Plug length before the pipe is withdrawn.
 - d. Length of mud freefall in drill pipe.
 - e. Displacement volume required to spot the plug.

8A.1.4.3 Plugging and Abandonment Procedure for “During Construction” Scenario:

Pumping the Cement Job

1. Trip in Hole (TIH) to the desired depth (drill pipe tags the base of the desired plug depth).
2. Shut down circulating trip tank on wellbore.
3. Break circulation and condition mud as required. Circulate at least until the pit levels stabilize.
4. Mix and pump cement and spacers.
5. Displace with the predetermined mud volume.

6. Shut down cementing unit and allow mud to freefall.
7. Near the end of the freefall, begin pulling out. Check to verify if we are pulling dry or wet. Slowly pull the drill string out of the plug and continue trip out of hole (TOH) until 300 ft +/- above the top of the plug. Slowly pump 5-10 bbls to clear the drill pipe.
8. Waiting on cement (WOC) minimum 12 hours, and TIH to tag the plug. If the plug will hold 5-10K lbs weight, pull up, circulate 1-2 stands above and continue with next plug.
9. After placing all plugs, pull out of hole (POOH) laying down all drill pipe.
10. Cut off all casings below the plow line (or per local, state or regulatory guidelines), dump 2-5 sacks of neat cement, and weld plate on top of casing stub. Place marker if required.
11. After rig is released, restore site to original condition as possible or per local, state or federal guidelines.
12. Complete plugging forms and send in with charts and all lab information to the regulatory agency as required by permit. Plugging report shall be certified as accurate by ADM and plugging contractor, and shall be submitted within 60 days after plugging is completed.

8A.1.4.4 Plugging and Abandonment Procedure for “End of Project” Scenario:

1. Notify the regulatory agency at least 60 days before commencing operations and provide updated plugging plan, if applicable.
2. Move-in (MI) Rig onto CCS #2 and rig up (RU). All CO₂ pipelines will be marked and noted with rig supervisor prior to MI.
3. Conduct and document a safety meeting.
4. Open up all valves on the vertical run of the tree and check pressures.
5. Test the pump and line to 2,500 psi. Fill casing with kill weight brine (9.5 ppg). Bleeding off occasionally may be necessary to remove all air from the system. Test casing annulus to 1000 psi. If there is pressure remaining on tubing rig to pump down tubing and inject two tubing volumes of kill weight brine. Monitor tubing and casing pressure for 1 hour. If both casing and tubing are dead then nipple up blowout preventers (NU BOP's). Monitor casing and tubing pressures.
6. If the well is not dead or the pressure cannot be bled off of tubing, rig up (RU) slickline and set plug in lower profile nipple below packer. Circulate tubing and annulus with kill weight fluid until well is dead. After well is dead, ND tree. NU BOP's and perform a function test. BOP's should have appropriate sized single pipe rams on top and blind rams in the bottom ram for tubing. Test pipe rams and blind rams to 250 psi low, 3,000 psi high. Test annular preventer to 250 psi low and 3,000 psi high. Test all TIW's,

IBOP's choke and kill lines, and choke manifold to 250 psi low and 3,000 psi high. NOTE: Make sure casing valve is open during all BOP tests. After testing BOPs pick up tubing string and unlatch seal assembly from seal bore. Rig slick line and lubricator back to well and remove X- plug from well. Rig to pump via lubricator and circulate until well is dead.

7. POOH with tubing laying it down. NOTE: Ensure that the well is over-balanced so there is no backflow due to formation pressure and there are at least 2 well control barriers in place at all times.

Contingency: If unable to pull seal assembly, RU electric line and make cut on tubing string just above packer. Note: Cut must be made above packer at least 5-10 ft MD.

8. If successful pulling seal assembly, then pick up workstring and TIH with Quantum packer retrieving tools. If tubing was cut in previous step then skip this step. Latch onto Quantum packer and pull out of hole laying down same. If unable to pull the Quantum packer, pull the work string out of hole and proceed to next step. Assuming the tubing can be pulled with the packer without issues, run CBL, casing caliper, RST and/ or USIT to assist in assessing wellbore mechanical integrity leakage around the wellbore above the caprock. If problems are noted, update cement remediation plan (if needed) and execute prior to plugging operations. TIH with work string to TD. Keep the hole full at all times. Circulate the well and prepare for cement plugging operations.
9. The lower section of the well will be plugged using CO₂ resistant cement from TD around 7000ft to around 1000ft above the top of the Eau Claire formation (to approximately 4000 ft). This will be accomplished by placing plugs in 500 ft increments. Using a density of 15.9 ppg slurry with a yield of 1.11 cf/sk, approximately 1150 sacks of cement will be required. Actual cement volume will depend upon actual weight of the casing within the plugged zone. This will require at least six plugs of 500 feet in length. No more than two plugs will be set before cement is allowed to set and plugs verified by setting work string weight down onto the plug.
10. Circulate the well and ensure it is in balance. Place tubing just above cement top from previous day. Mix and spot 500 ft balanced plug in 9 5/8 inch casing (approximately 191 sacks Class H). Pull out of plug and reverse circulate tubing. Repeat this operation until a total of 8 plugs have been set. If plugs are well balanced then the reverse circulation step can be omitted until after each third plug. Lay down work string while pulling from well. If rig is working daylight only then pull 10 stands and rack back in derrick and reverse tubing before shutting down for night. After waiting overnight, trip back in hole and tag plug and continue. After ten plugs have been set pull tubing from well and shut in for 12 hours. Trip in hole with tubing and tag cement top. Calculate volume for final plug. Pull tubing back out of well. Nipple down BOPs and cut all casing strings below plow line (min 3 feet below ground level or per local policies/standards and ADM requirements). Trip in well and set final cement plug. Total of approximately 1530 sacks total cement used in all remaining plugs above 4000 feet. Lay down all work string, etc. Rig down all equipment and move out. Clean cellar to where a plate can be welded with well name onto lowest casing string at 3 feet, or as per permitting agency directive.

11. Complete plugging forms and send in with charts and all lab information to the regulatory agency as required by permit. Plugging report shall be certified as accurate by ADM and plugging contractor, and shall be submitted within 60 days after plugging is completed.

SECTION 8B - VERIFICATION WELL PLUGGING & ABANDONMENT PROCEDURES

8B.1 Description of Plugging Procedures

Upon completion of the project, or at the end of the life of Verification Well #2, the well will be plugged and abandoned to meet all applicable requirements. The need to abandon the well prior to any injection (i.e. during construction) is also a possibility. The plug procedure and materials will be designed to prevent any unwanted fluid movement and to protect any USDWs. The well plugging procedure and design will be updated in the well plugging plan based on any new information gained during well construction and testing. The final plugging plan will be developed after collaboration and interaction with the UIC Program Director; however, to fulfill permit requirements, we propose the preliminary plan which follows.

8B.1.1 Abandonment during Construction

Abandonment during well construction, while sections of the wellbore are uncased could take place while: (1) drilling the surface hole (≤ 350 ft), (2) drilling intermediate hole ($\leq 5,300$ ft), or (3) drilling long-String hole ($\leq 7,500$ ft).

During each scenario, the drill string (drill collars, drill pipe, and drill bit) represents the most likely risk for leaving equipment in the hole. Although unlikely, it is possible that a logging tool, core barrel, or other piece of equipment can get stuck and be left in the hole. Every attempt will be made to recover all portions of the string or other equipment prior to abandonment.

If equipment cannot be retrieved and must be abandoned in the wellbore, no unique plugging procedure should be required and the plugs will be placed as specified in the plugging plan. Plug placement will depend upon depth of the hole, the geology and the depth that the equipment was lost in the well. If the well has not penetrated or is not within 100 feet of the caprock, then typically plugging during construction would require placing plugs across any zones capable of producing fluid and at the previous casing shoe. A surface plug will be set and the well filled with drilling mud between the plugs. If the caprock has been penetrated when the well is judged to be lost, the well will be plugged using CO₂-resistant cement from TD to 1,000 feet above the caprock seal using the balanced plug method. This may require setting multiple plugs. If this occurs, each plug will be verified before moving to the next.

If a radioactive logging source is lost in the hole (e.g. a density and/ or neutron porosity logging source), current Nuclear Regulatory Commission (NRC) regulations will be followed. A 300-foot red cement plug will be placed immediately above the lost logging tool. An angled kick-plate will be placed above this plug to divert any subsequent drilling that may coincidentally enter this wellbore. Current NRC regulations require that the surface casing remain extended above the ground surface with an informative ground plate welded to the pipe. The plate includes information to identify what is in the hole. Depending upon where in the well the radioactive source is lost, plugging above the kick-plate will proceed as described above.

Plug Placement Method: The method of placing the plugs in Verification Well #2 is the “Balanced Plug” method. This is a basic plug spotting process that is generally considered more efficient and is consistent with best industry practices.

8B.1.2 Abandonment at End of project

After injection has ceased, the well will be flushed with a kill weight brine fluid. A minimum of three tubing volumes will be injected without exceeding fracture pressure. Detailed plugging procedure is provided in Section 8B.1.4 below. All casing in this well will be cemented to surface and will not be retrievable at abandonment. After injection ceases and after the appropriate post-injection monitoring period is finished, the completion equipment will be removed from the well.

8B.1.3 Type and Quantity of Plugging Materials, Depth Intervals

The volume and depth of the plug or plugs will depend on the final geology and downhole conditions of the well as assessed during construction. Well cementing software (e.g. Schlumberger's CemCade) will be used to model the plugging and aid in the plug design. The cements used for plugging will be tested in the lab prior to plug placement and both wet and dry samples will be collected during plugging for each plug to ensure quality of the plug.

All of the casing strings will be cut off at least 3 feet below the surface, below the plow line. A blanking plate with the required permit information will be welded to the top of the cutoff casing.

8B.1.4 Detailed Plugging and Abandonment Procedures

8B.1.4.1 Notifications, Permits, and Inspections (Prior to Workover or Rig Movement).

Notifications, permits, and inspections are the same for plugging and abandonment during construction and post-injection.

- 1) Notify the regulatory agency at least 60 days prior to commencing plugging operations. (Note that this timeline will not apply for plugging and abandonment during well construction.) Provide updated plugging plan, if applicable. Ensure proper notifications have been given to all regulatory agencies for rig move.
- 2) Ensure that the plugging procedure has been reviewed and agreed upon by regulatory agency.
- 3) Ensure in advance that a pre-site inspection has been performed and the rig company has visited the site and is capable of transporting rig, tanks & ancillary equipment to perform P&A operations. Notify all key third parties of expected work scope, and ensure third party contracts for work are in place prior to move in.
- 4) Have copies of all government permits prior to initiating operations and maintain on location at all times. Check to see if conditions of approval have been met.
- 5) Make sure partners (U.S. DOE, EPA and ADM) approvals have been obtained, as applicable.

A site-specific list of facility contacts will be developed and maintained during the life of the project.

8B.1.4.2 Volume Calculations

Volumes will be calculated for specific abandonment wellbore environment based on desired plug diameter and length required. Volume calculations are the same for plug and abandonment during construction and post-injection.

- 1) Choose the following:
 - a. Length of the cement plug desired.
 - b. Desired setting depth of base of plug.
 - c. Amount of spacer to be pumped ahead of the slurry.

- 2) Determine the following:
 - a. Number of sacks of cement required.
 - b. Volume of spacer to be pumped behind the slurry to balance the plug.
 - c. Plug length before the pipe is withdrawn.
 - d. Length of mud freefall in drill pipe.
 - e. Displacement volume required to spot the plug.

8B.1.4.3 Plugging and Abandonment Procedure for “During Construction” Scenario:

Pumping the Cement Job

1. Trip in Hole (TIH) to the desired depth (drill pipe tags the base of the desired plug depth).
2. Shut down circulating trip tank on wellbore.
3. Break circulation and condition mud as required. Circulate at least until the pit levels stabilize.
4. Mix and pump cement and spacers.
5. Displace with the predetermined mud volume.
6. Shut down cementing unit and allow mud to freefall.
7. Near the end of the freefall, begin pulling out. Check to verify if we are pulling dry or wet. Slowly pull the drill string out of the plug and continue trip out of hole (TOH) until 300 ft +/- above the top of the plug. Slowly pump 5-10 bbls to clear the drill pipe.
8. Waiting on cement (WOC) minimum 12 hours, and TIH to tag the plug. If the plug will hold 5-10,000 lbs weight, pull up, circulate 1-2 stands above and continue with next plug.
9. After placing all plugs, pull out of hole (POOH) laying down all drill pipe.

10. Cut off all casings below the plow line (or per local, state or regulatory guidelines), dump 2-5 sacks of neat cement, and weld plate on top of casing stub. Place marker if required.
11. After rig is released, restore site to original condition as possible or per local, state or federal guidelines.
12. Complete plugging forms and send in with charts and all lab information to the regulatory agency as required by permit. Plugging report shall be certified as accurate by ADM and shall be submitted within 60 days after plugging is completed.

8B.1.4.4 Possible Plugging and Abandonment Procedure for “End of Project” Scenario:

At the end of the serviceable life of the verification well, the well will be plugged and abandoned. In summary, the plugging procedure will consist of removing all components of the completion system and then placing cement plugs along the entire length of the well. At the surface the well head will be removed and casing cut off 3 feet below surface. A detailed procedure follows:

1. Move in workover unit with pump and tank.
2. Fill both tubing and annulus with kill weight brine.
3. Nipple down well head and nipple up BOPs.
4. Remove all completion equipment from well. This will require deflating the Westbay packers and removing all Westbay equipment from the well.
5. Keep hole full with workover brine of sufficient density to maintain well control.
6. Pick up 2 7/8” tbg work string (or comparable) and trip in hole to PBTD.
7. Circulate hole two wellbore volumes to ensure that uniform density fluid is in the well.
8. The lower section of the well will be plugged using CO₂ resistant cement from TD around 7000ft to around 1000ft above the top of the Eau Claire formation (to approximately 4000 ft). This will be accomplished by placing plugs in 500 ft increments. Using a density of 15.9 ppg slurry with a yield of 1.11 cf/sk, approximately 360 sacks of cement will be required. Actual cement volume will depend upon actual weight of the casing within the plugged zone. This will require at least six plugs of 500 feet in length. No more than two plugs will be set before cement is allowed to set and plugs verified by setting work string weight down onto the plug.
9. Pull ten stands of tubing (600 ft) out and shut down overnight to wait on cement curing
10. After appropriate waiting period, TIH ten stands and tag the plug. Resume plugging procedure as before and continue placing plugs until the last plug reaches the surface.

11. Nipple down BOPs.
12. Remove all well head components and cut off all casings below the plow line.
13. Finish filling well with cement from the surface if needed. Total of approximately 413 sacks total cement used in all remaining plugs above 4000 feet. Lay down all work string, etc. Clean cellar to where a plate can be welded with well name onto lowest casing string at 3 feet, or as per permitting agency directive.
14. If required, install permanent marker back to surface on which all pertinent well information is inscribed.
15. Fill cellar with topsoil.
16. Rig down workover unit and move out all equipment. Haul off all workover fluids for proper disposal.
17. Reclaim surface to normal grade and reseed location.
18. Complete plugging forms and send in with charts and all lab information to the regulatory agency as required by permit. Plugging report shall be certified as accurate by ADM and shall be submitted within 60 days after plugging is completed.

Note: 7,500 ft 5 ½" 15.5 lb/ft casing requires an estimated 930 cubic feet of cement to fill, 14 plugs.

Approximately five days required from move in to move out, depending on the operations at hand and the physical constraints of the well, weather, and other conditions.

SECTION 8C - GEOPHYSICAL MONITORING WELL PLUGGING & ABANDONMENT PROCEDURES

As the geophysical monitoring well does not penetrate the cap rock above the Mt. Simon Sandstone, plugging and abandonment procedures will follow typical practice for well sealing.

8C.1 Description of Plugging Procedures

At the end of the serviceable life of the well, the well will be plugged and abandoned utilizing the following procedure:

1. Notify the permitting agency of abandonment at least 60 days prior to plugging the well.
2. Cement may be circulated from total depth or plugged-back total depth to surface or cement plugs may be placed as specified below.
 - a. Cement plug circulated or dump bailed over any perforated interval (none planned).
 - b. Cement plug circulated inside casing from 500 feet to a minimum of 250 feet.
 - c. Third possible method would be to perforate the St. Peter Sandstone at the bottom of the 4 ½ inch tubing that is run in the well as casing. Establish injection rate using fresh water. Mix and pump appropriate number of sacks to fill 4 ½ inch tubing and inject into well. Shut down and monitor pressure. If cement falls back inside tubing then mix and pump enough cement to refill. Continue until well is static with cement and monitor for 12 hours.
3. Cut off all well head components and cut off all casings below the plow line.
4. Finish filling well with cement.
5. Install permanent marker at surface, or as required by the permitting agency.
6. Reclaim surface to normal grade and reseed location.

SECTION 9 – POST-INJECTION SITE CARE AND SITE CLOSURE

9.1 Description of Post-injection site care and closure

Post injection site care and closure (PISC) will be conducted to meet the requirements of 40 CFR 146.93. Upon the cessation of injection, the most recent monitoring data and modeling results will be reviewed with respect to the final PISC plan. If no changes to the PISC plan are warranted a report detailing these results will be submitted to the Director. If changes to the PISC plan are necessary, an amended PISC plan will be submitted to the Director for approval and incorporation into the permit subject to the permit modification requirements at §§ 144.39 or 144.41.

In this PISC plan, the operator requests to close the site (final site closure) before the default 50 year period described in § 146.93(c). The operator requests a modified PISC timeframe of 10 years. This PISC period is based on current monitoring and other site-specific data which demonstrate that the sequestered CO₂ will no longer pose an endangerment to USDWs and will meet the requirements for an alternative PISC period as detailed in § 146.93(c)(1) and (2).

9.1.1 *Description of Post-injection Monitoring*

During the PISC period, the operator will continue to conduct site monitoring and modeling to demonstrate that the injected CO₂ (plume) is responding as predicted and will not endanger USDWs. The site monitoring program will be a continuation of the operational monitoring, verification, and accounting (MVA) program. Table 9-1 details MVA activities during the site's pre-injection, injection, and post injection periods. In Table 9-2 the post-injection monitoring schedule is presented. During the PISC period, the operator will continue to use seismic surveys, well based pressure measurement, and sample analysis to monitor the condition of the injectate. The following paragraphs detail the post-injection monitoring techniques to be employed in this program:

- 1) Seismic survey: in order to define the location and extent of the CO₂ plume, seismic surveys will be designed, acquired, and interpreted for the area of review (AoR) upon completion of the injection period and 10 years later at the completion of the PISC period. The optimum survey lines for the post-closure seismic surveys will be determined using all historic site specific seismic data and updated reservoir model results. These surveys will be used to validate the site models, determine the position and extent of the CO₂ plume, and verify that the CO₂ will not pose an endangerment to USDWs. Further need for seismic surveying and extension of the PISC period will be evaluated based on the measured extent of the plume, the plume's rate of expansion, correlation with site modeling results, and potential risk of endangerment to USDWs.
- 2) Shallow groundwater monitoring: samples will be taken from the existing shallow groundwater regulatory compliance wells. The schedule for monitoring will be quarterly in year one (1) and annually thereafter. The groundwater monitoring program will follow the plan defined in Section 6A.2.4 - Detailed Groundwater Monitoring Plan.

- 3) Injection well monitoring: during PISC period the injection well will be used to monitor the pressure and temperature at the injection site within the Mt. Simon Sandstone.
- 4) Verification well monitoring: The verification well will be used to monitor the pressure and temperature at the verification site within the Mt. Simon Sandstone.
- 5) Geophysical well monitoring: The geophysical well will allow for continued 3D VSP surveys, and pressure monitoring near the injection site within the St. Peter Sandstone as warranted.

Because the PISC monitoring is a continuation of the operational monitoring, there will be no modification in the well monitoring plan and sample locations. Figures 9-1 and 9-2 show the locations of the PISC monitoring wells.

During the PISC period, additional seismic and well-based monitoring data will be generated, validated, and analyzed using the procedures described in the quality assurance plan. In order to validate the fate of the injectate and ensure the CO₂ poses no endangerment of USDWs throughout the PISC period, new data will be generated, validated, and utilized in updating the site specific models. As required in § 146.93(a)(2)(i), data analysis and modeling results will be used to calculate and monitor the injection zone pressure differential between the pre- and post-injection periods. The results from seismic acquisitions, well based pressure monitoring, sample analysis, and site models will be used to establish the boundaries of the CO₂ plume and the associated pressure front as required by § 146.93(a)(2)(ii).c.

Table 9-1: Summary of Monitoring, Verification and Accounting Activities

| Monitoring Activity Description | Monitoring Period | | |
|--|-------------------------------|------------------|----------------|
| | Pre-CO ₂ Injection | During Injection | Post Injection |
| Seismic Survey | X | X | X |
| Shallow groundwater regulatory compliance wells - water quality | X | X | X |
| Injection Well Monitoring - injection volumes | | X | |
| Injection Well Monitoring - injection well surface pressure | X | X | X |
| Injection Well Monitoring - annulus pressure | X | X | X |
| Verification Well Monitoring - injection formation pressure | X | X | X |
| Verification Well Monitoring - injection formation temperature | X | X | X |
| Geophysical Well Monitoring – Vertical Seismic Profiling | X | X | X |
| Geophysical Well Monitoring - formation pressures | X | X | X |
| Injection and Verification Wells – downhole CO ₂ detection e.g. RST surveys | X | X | X |

Table 9-2: Summary of Post-Injection Monitoring Schedule

| Monitoring Activity Description | Schedule |
|---|--|
| Seismic Survey | Immediately following cessation of injection |
| Seismic Survey | After 10 years |
| Shallow groundwater regulatory compliance wells - water quality | Quarterly (Year 1) & Annually (Year 2+) |
| Injection Well Monitoring - injection well tubing head pressure | Annually |
| Injection Well Monitoring - annulus pressure | Continuous |
| Verification Well Monitoring - injection formation pressure | Continuous |
| Verification Well Monitoring - injection formation temperature | Continuous |
| Geophysical Well Monitoring - formation pressures | Continuous |
| Injection and Verification Wells– RST Surveys | Post Injection Years 1, 4, 9 |

9.1.2 Schedule for Submitting Post-injection Site Care Monitoring Results

Post-injection site care monitoring data and modeling results will be submitted to the EPA in an annual report. The report will be submitted in an electronic format approved by the EPA. The annual reports will contain information and data generated during the reporting period; i.e. seismic data acquisition, well-based monitoring data, sample analysis, and the results from updated site models.

9.1.3 Post-injection Site Care Timeframe

The default timeframe for post-injection site care is fifty years; however, the operator is seeking an alternate timeframe based on consideration and documentation of site specific conditions that satisfy the requirements listed in § 146.93(c)(1) and (2). These site specific conditions are described in the following paragraphs. Please note that the specific section for each criterion in the CFR is listed in square brackets, [].

- [§146.93(c)(1)(i)] The results of computational modeling of the project (Section 5.4 of this application) indicate that the sequestered CO₂ will not migrate above the Mt. Simon Sandstone.
- [§146.93(c)(1)(ii)] The formation pressure at the injection well is predicted to decline rapidly within the first 4 years following injection (formation pressure pre-injection = 2,840 psia, immediately following injection = 3,340 psia, 4 years post-injection = 2,950 psia). Fifty years post-injection, the formation pressure is predicted to be 2,860 psia. Furthermore, the increase in the injection formation pressure at the edge of the AoR is expected to be less than 185 psi at the cessation of injection, less than 110 psi 4 years later, and continues dropping to less than 10 psi at the end of fifty years.
- [§146.93(c)(1)(ii)] The hydrogeologic and seismic characterization for the project site indicates that the Eau Claire Formation, the primary seal above the Mt. Simon, does not contain any faults and has permeability sufficiently low to impede CO₂ migration

to overlying formations.

- [§146.93(c)(1)(viii) and (ix)] Potential conduits of CO₂ migration above the Mt. Simon are limited to the IBDP injection and verification wells or the IL-ICCS injection and verification wells, all of which will be constructed, monitored, and plugged in a manner that will minimize the potential for any such migration and meets the requirements of 40 CFR Part 146.
- [§146.93(c)(1)(x)] The Mt. Simon Sandstone is nearly 7,000 feet below the lowermost USDW, and there are three confining formations (New Albany Shale, Maquoketa Formation, Eau Claire Formation) between the injection zone and the lowermost USDW. If the EPA requires post-injection monitoring beyond the ten-year timeframe outlined in this plan, the operator will work with the Director to establish the monitoring activities, frequency, and duration of the PISC period.

9.1.4 Site Closure

The operator will notify the permitting agency at least 120 days prior of its intent to close the site. Once the permitting agency has approved closure of the site, all remaining monitoring wells will be plugged and abandoned in accordance with the methods described in Sections 8A, 8B, and 8C of this application. A site closure report will be prepared within 90 days following site closure, documenting the following:

- plugging of the injection, verification, and geophysical wells,
- location of sealed injection well on a plat of survey that has been submitted to the local zoning authority,
- notifications to State and local authorities,
- records regarding the nature, composition, and volume of the injected CO₂
- post-injection monitoring records.

Notation to the property's deed on which the injection well was located shall indicate the following:

- property was used for carbon dioxide sequestration,
- name of the local agency to which a plat of survey with injection well location was submitted,
- the volume of fluid injected,
- the formation into which the fluid was injected, and
- the period over which the injection occurred.

The site closure report will be submitted to the permitting agency and maintained by the operator for a period of 10 years following site closure. Additionally, the operator will maintain the records collected during the PISC period for a period of 10 years after which these records will be delivered to the Director.

Figure 9-1 - Location information for proposed wells and other facilities.

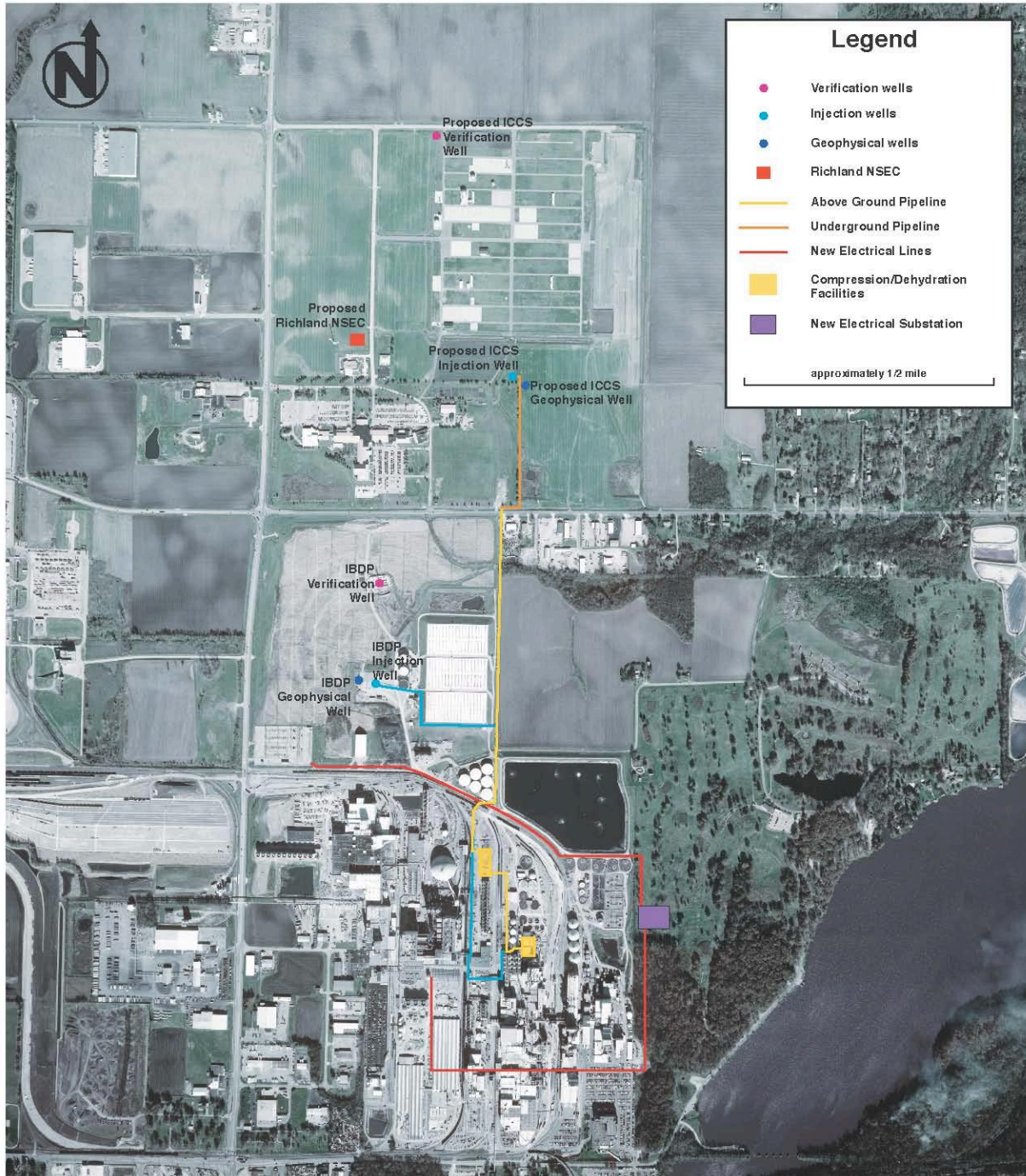

Figure 9-2: Shallow ground water compliance wells will include two wells within 200 feet of the injection well, one additional well within 400 feet, and a fourth compliance well will be within 2000 feet of CCS #2 injection well. The precise location of these wells are yet to be determined and will be documented in the completion report.



APPENDIX A

APPENDIX A - Financial Assurance Documentation

Applicant will provide the permitting agency with the required financial assurance documentation after the appropriate costs are proposed and validated by both parties. The Applicant will provide financial assurance in a form approved by the permitting agency for AoR corrective action, injection well plugging, post-injection site care, and emergency and remedial response.

The financial assurance plan will be submitted before or with the well completion report.







APPENDIX B

APPENDIX B – CO₂ Resistant Cement Technical Specifications

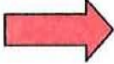
CO₂ Resistant Cement

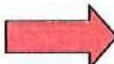
Temperature range (BHST): 40 – 110 degC (104 – 230 degF)

Density range: 12.5 – 16.0 lbm/gal [1.5 – 1.92 SG]

| System | Initial | | 6 months |
|------------------------------|---|--|---|
| Portland Cement 15.8 lbm/gal |  |  |  |
| CRC 15.8 lbm/gal |  |  |  |
| CRC 12.5 lbm/gal |  |  |  |

Physical aspect of conventional Portland and CRC before and after six months in carbon dioxide environments at 280 bars – 90 degC

Properties of the CRC slurry as a function of the density and of the BHCT

| | | | | | | |
|--|--------------------|-----------|----------|---------------------|-----------|----------|
| Design | | | | | | |
| BHCT | 40 degC [104 degF] | | | 85 degC [185 degF] | | |
| BHST | 50 degC [122 degF] | | | 110 degC [230 degF] | | |
| Specific gravity [lbm/gal] | 12.5 | 14.5 | 15.8 | 12.5 | 14.5 | 15.8 |
| Rheological properties determined with R1B5 | | | | | | |
| After mixing | | | | | | |
| PV (cp) | 247 | 234 | 208 | 264 | 214 | 175 |
| T _y (lbf/100ft ²) | 4.5 | 8.5 | 9 | 16.5 | 16.8 | 11.4 |
| After conditioning at BHCT | | | | | | |
| PV (cp) | 262 | 292 | 207 | 189 | 216 | 226 |
| T _y (lbf/100ft ²) | 4.4 | 11.2 | 15 | 9.0 | 2.2 | 2.7 |
| 10" [deg] | 5 | 8 | 7 | 4 | 3 | 4 |
| 10' [deg] | 41 | 40 | 32 | 40 | 32 | 33 |
| 1' [deg] | 9 | 14 | 14 | 10 | 8 | 8 |
| Stability | Ok | Ok | Ok | Ok | Ok | Ok |
| API Fluid loss at BHCT | 34 | 40 | 54 | 54 | 56 | 50 |
| Thickening time at BHCT | | | | | | |
| 30 Bc | 6h 03min | 5h 04min | 3h 54min | 4h 25min | 5h 22min | 6h 20min |
| 70 Bc | 7h 01min | 5h 43min | 4h 31min | 4h 39min | 5h 33min | 6h 28min |
| UCA at BHST | | | | | | |
| 50 psi | 9h 52min | 9h 04min | 6h 16min | 10h 08min | 9h 56min | 6h 16min |
| 500 psi | 11h 24min | 11h 20min | 8h 04min | 10h 36min | 10h 36min | 6h 52min |
| CS at 24h [psi] | 3036 | 2396 | 2982 | 2459 | 3463 | 2882 |



Client Cement Support Laboratory
16115 Park Row, Suite 190
Houston, Texas 77084

Laboratory Cement Test Report - CO₂ Resistant EverCRETE®

| | | | |
|------------------------|---------------------------|---------------------------|--------------------------------|
| Fluid No : CCS08040004 | Client : ADM Company | Location : Illinois Basin | Signatures |
| Date : Jun-6-2008 | Well Name : CO2 Injection | Field : Mt. Simon | Terry Dammel Lab Specialist |

| | | | | | |
|-------------------|----------|------------------|-------------|--------------|---------------|
| Job Type | Casing | Depth | 7500 ft | TVD | 7500 ft |
| BHST | 130 degF | BHCT | 110 degF | BHP | 2900 psi |
| Starting Temp. | 80 degF | Time to Temp. | 00:29 hr:mn | Heating Rate | 1.03 degF/min |
| Starting Pressure | 400 psi | Time to Pressure | 00:29 hr:mn | Schedule | 9.5-2 |

| | | | | | |
|---------------------|--------------|----------|--------------------------|-------------|-------------|
| Composition | | | | | |
| Slurry Density | 15.80 lb/gal | Yield | 1.09 ft ³ /sk | Mix Fluid | 3.42 gal/sk |
| Solid Vol. Fraction | 58.0 % | Porosity | 42.0 % | Slurry type | Other |

EverCRETE® Blend 1.9 SG pilot

| Code | Mass Per Sack |
|--------------|---------------|
| D189 CSL Hou | 30 lb |
| S100 CLS Hou | 57 lb |
| D195 CLS Hou | 2 lb |
| D178 CSL Hou | 11 lb |

| Code | Concentration | Sack Reference | Component | Blend Density | Lot Number |
|--------------|---------------|-----------------|------------|------------------------|------------|
| 1.9 SG pilot | | 100 lb of BLEND | Blend | 2.54 g/cm ³ | W2007.0150 |
| Mix water | 3.16 gal/sk | | Base Fluid | | |
| D175 | 0.03 gal/sk | | Antifoam | | W2002-0033 |
| D168 | 0.17 gal/sk | | Fluid loss | | W2007.0289 |
| D080 | 0.05 gal/sk | | Dispersant | | W2007.0398 |
| D081 | 0.01 gal/sk | | Retarder | | W2005.0253 |

Rheology (Average readings) (R1, B1, F1)

| (rpm) | (deg) | (deg) |
|-------|-------|-------|
| 300 | 163.0 | 163.0 |
| 200 | 119.5 | 122.5 |
| 100 | 71.5 | 75.0 |
| 60 | 48.5 | 51.5 |
| 30 | 29.5 | 32.0 |
| 6 | 11.0 | 11.0 |
| 3 | 8.0 | 7.0 |

| | | |
|----------------|--|----|
| 10 sec Gel | | 8 |
| 10 min Gel | | 27 |
| 1 min Stirring | | 15 |

| | | |
|-------------|---------|----------|
| Temperature | 80 degF | 110 degF |
|-------------|---------|----------|

| | |
|---|---|
| k : 1.29E-2 lbf.s ⁿ /ft ² | k : 1.92E-2 lbf.s ⁿ /ft ² |
| n : 0.781 | n : 0.719 |
| T _y : 3.38 lb/100ft ² | T _y : 1.22 lb/100ft ² |

Thickening Time Results

| Consistency | Time (Lab DI Water) | Time (Com Processing Water) | Time (Treated Waste Water) |
|-------------|---------------------|-----------------------------|----------------------------|
| POD : | 3:22 hr:mn | 2:45 hr:mn | 5:24 hr:mn |
| 30 Bc | 4:09 hr:mn | 3:32 hr:mn | 4:20 hr:mn |
| 70 Bc | 5:05 hr:mn | 4:27 hr:mn | 6:18 hr:mn |
| 100 Bc | 5:14 hr:mn | 4:39 hr:mn | 6:29 hr:mn |

NOTE: Testing at a higher pressure of 4550 psi in 39 minutes resulted in a thickening time of 4:07 hr:mn to 70 Bc with DI Water. This compares to the time of 5:05 hr:mn at 2900 psi in 29 minutes.

Free Fluid

| | |
|-----------------------------|----------|
| 0.0 mL/250mL. | in 2 hrs |
| At 110 degF and 0 deg incl. | |
| Sedimentation | None |

Client : ADM Company
 String : Casing L/S
 Country : USA

Well : Mt. Simon Sandstone
 District : Illinois Basin



Fluid Loss

| | |
|---|-------|
| API Fluid Loss | 36 mL |
| 18 mL in 30:00 mn:sc at 110 degF and 1000 psi | |

UCA Compressive Strength @ 130°F

| Time | CS |
|-------------|----------|
| 06:04 hr:mn | 50 psi |
| 07:25 hr:mn | 500 psi |
| 12:00 hr:mn | 1604 psi |
| 24:00 hr:mn | 3322 psi |
| 72:00 hr:mn | 4379 psi |

Crush CS (water bath @ 130°F)

| Time | CS |
|----------|-----------------|
| 24 hours | 3230 psi |
| Time | Young's Modulus |
| 24 hours | 1,004,400 psi |

Comments

General Comment: Thickening Time test with new Location Water source from ADM Corn Processing
 Fann Reading Comment: R1, B1, F1.
 Thickening Time Comment: See attached plot with varying retarder D081 concentrations.
 Other test Comment: Fluid Loss tested with filter paper.

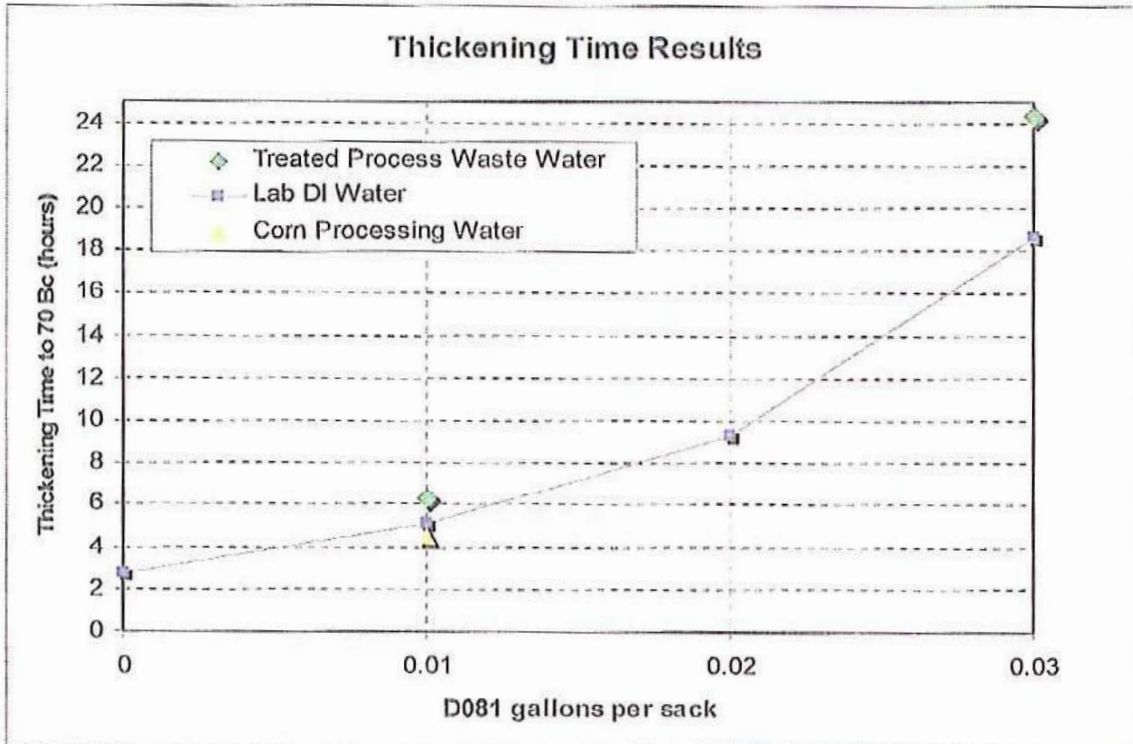

Thickening Time Test with Corn Processing Mix Water

Client : ADM Company
String : Casing L/S
Country : USA

Well : Mt. Simon Sandstone
District : Illinois Basin

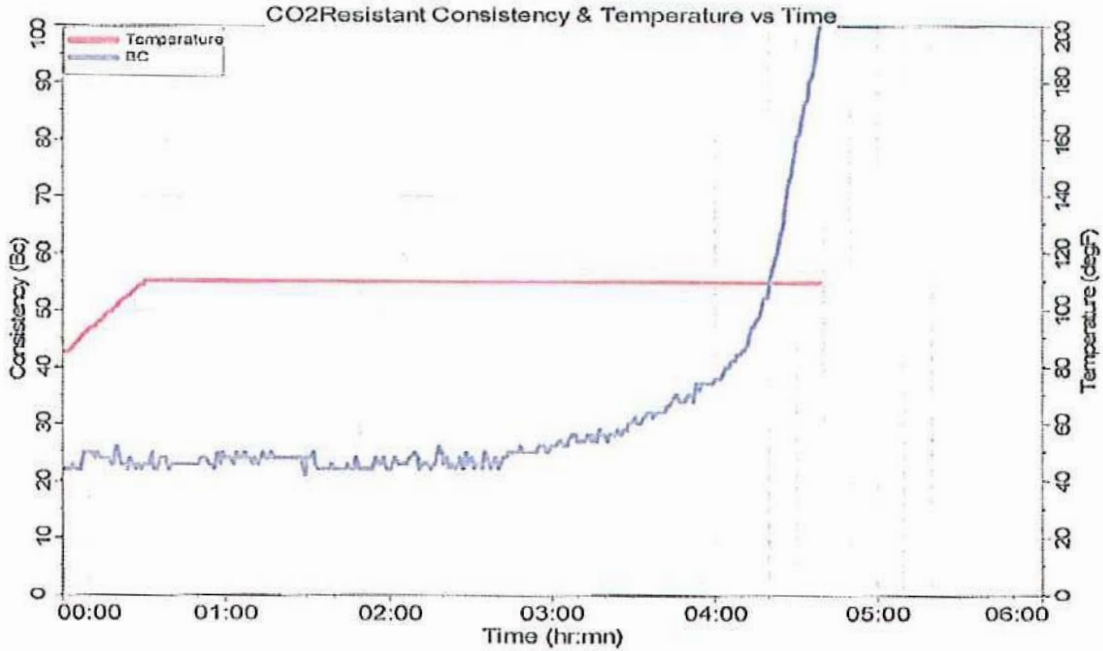
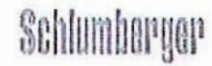

Thickening Time Test with Lab DI Mix Water

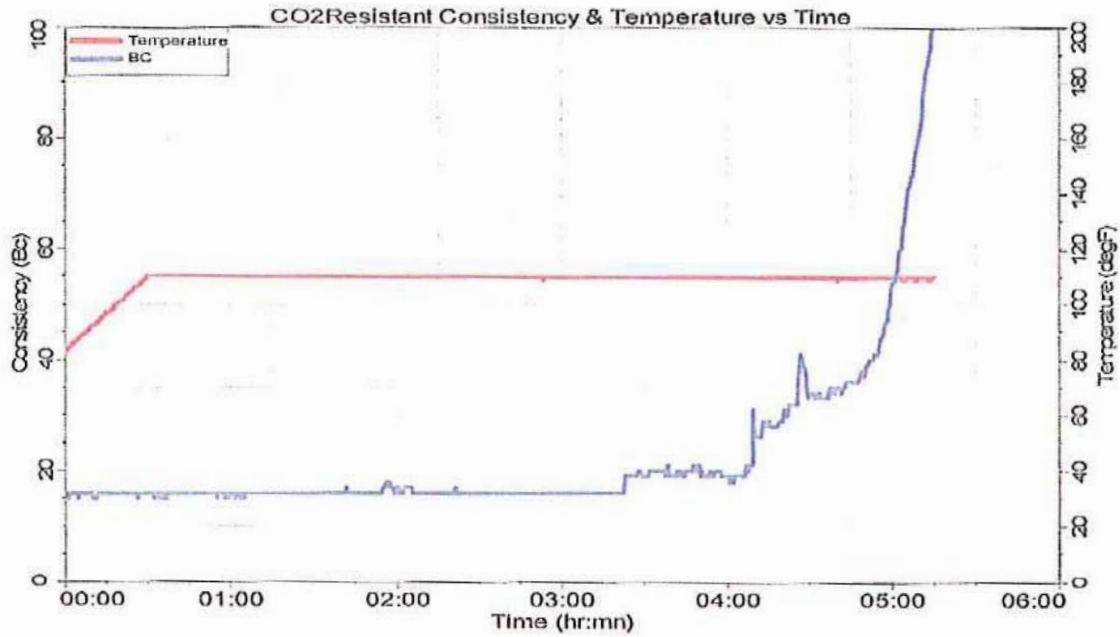

Ultrasonic Cement Analyzer Strength Test at 130°F

Client : ADM Company
String : Casing L/S
Country : USA

Well : Mt. Simon Sandstone
District : Illinois Basin

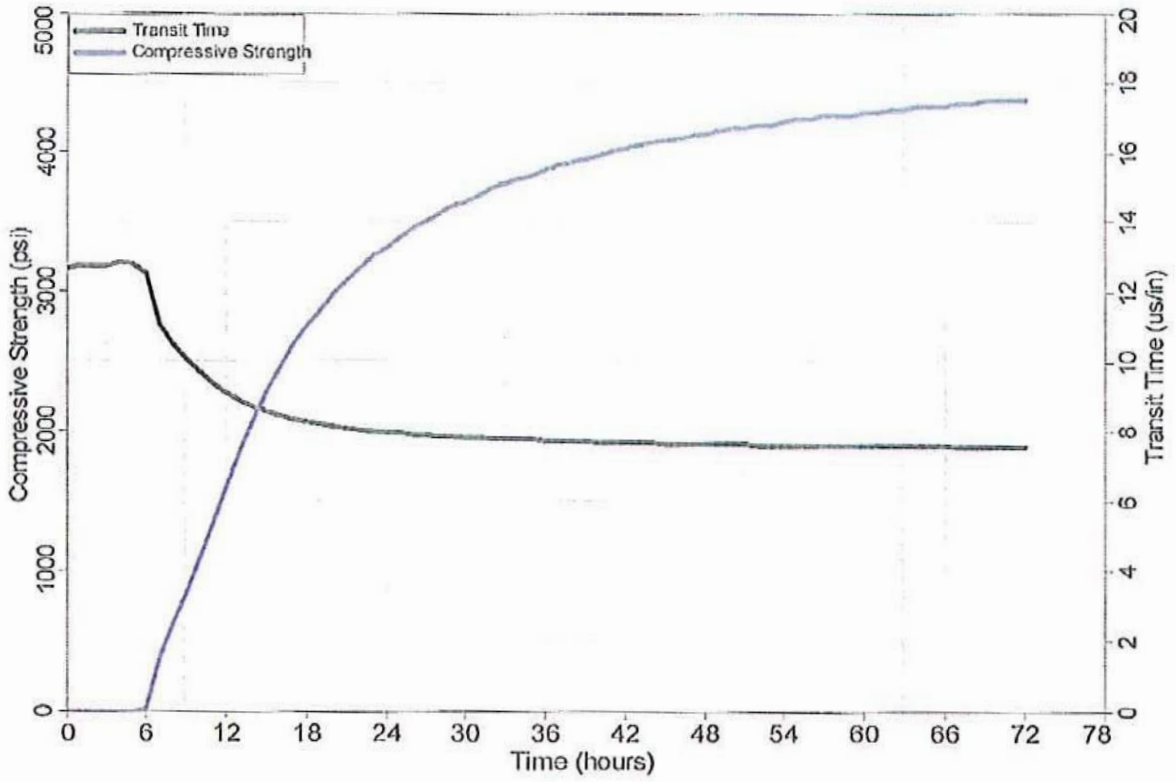

APPENDIX C

APPENDIX C – Surface Facility Process Instrument Diagrams

The following are the surface facility process and instrument diagrams (PIDs) for the booster pumps and the injection well. The applicant can upon request provide the agency a complete set of PIDs but does not wish to make them a part of the permit package because they are considered proprietary and confidential.

These PIDs have been approved for engineering but are still under engineering review. Minor details related to process control and instrument nomenclature may change during this review period. Therefore, the applicant will provide the permitting agency with the “as built” set of PIDs before or with the well completion report.

PROCESS PIPING PROCESS PIPING EQUIPMENT EQUIPMENT GENERAL GENERAL GENERAL GENERAL GENERAL GENERAL GENERAL

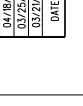
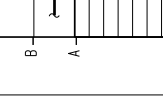
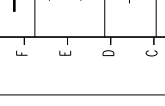
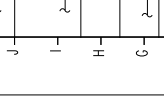
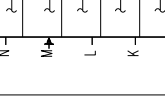
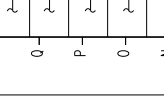
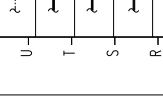
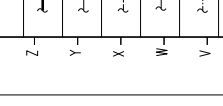
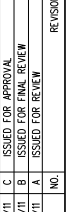
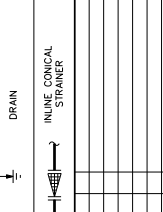
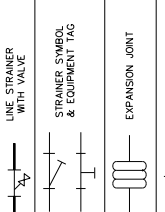
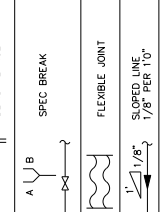
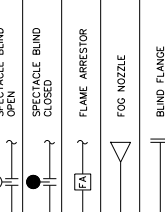
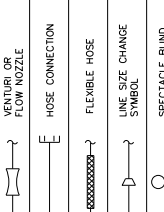
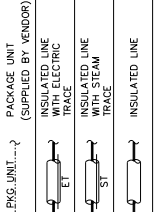
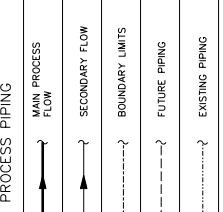
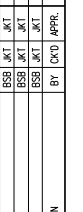
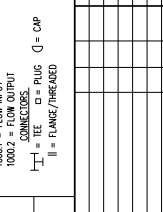
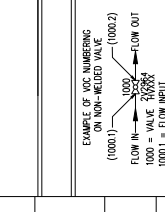
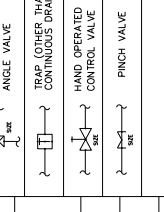
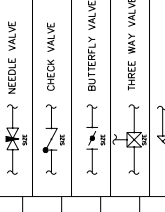
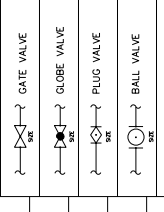
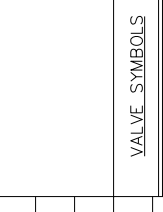
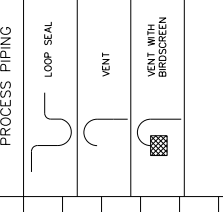
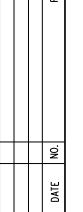
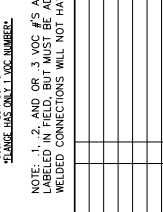
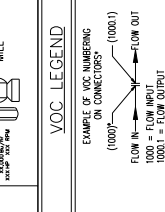
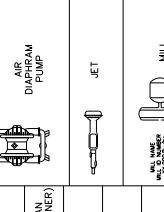
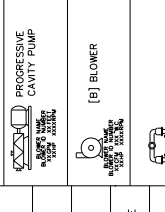
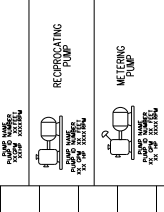
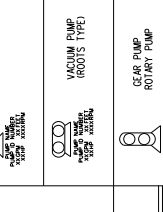
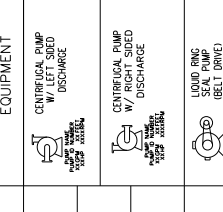
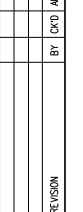
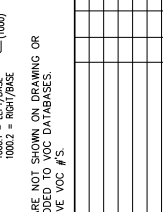
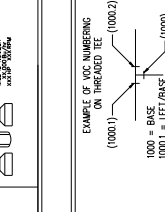
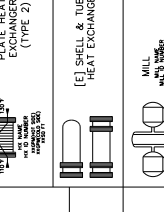
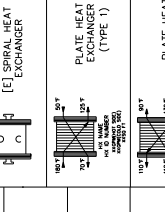
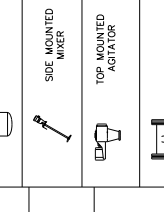
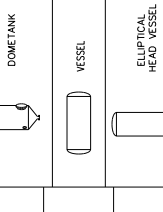
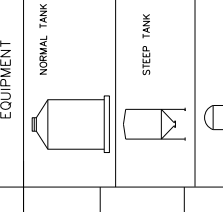
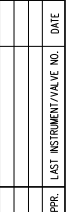
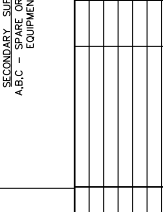
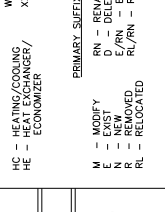
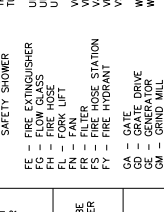
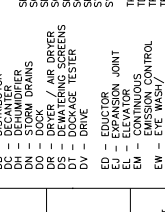
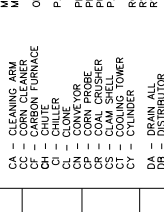
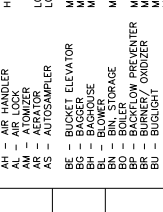
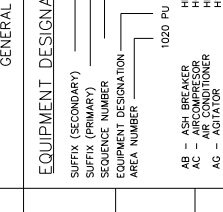
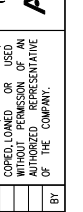
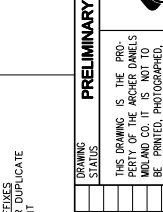
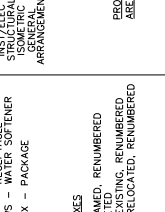
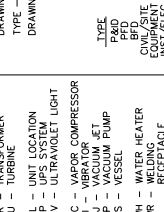
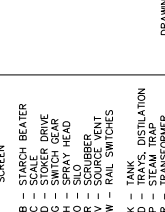
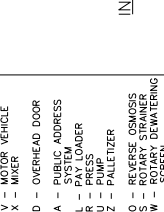
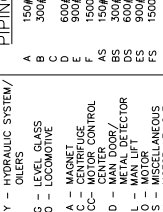
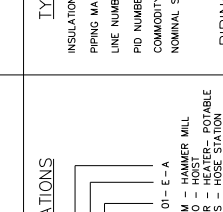
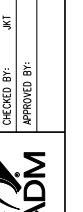
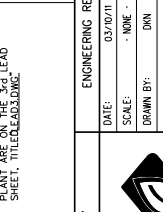
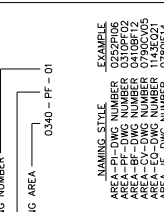
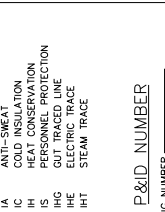
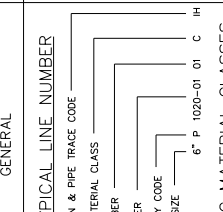
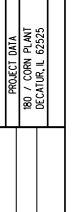
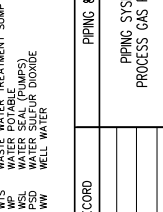
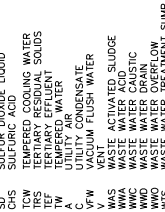
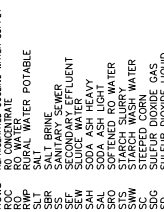
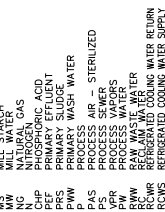
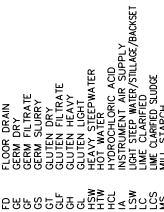
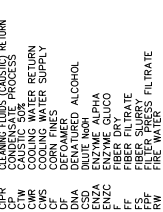
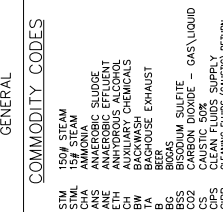
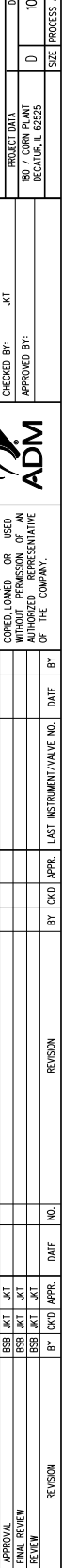
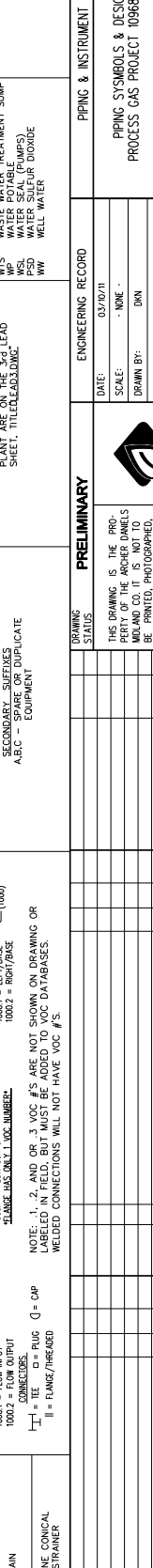
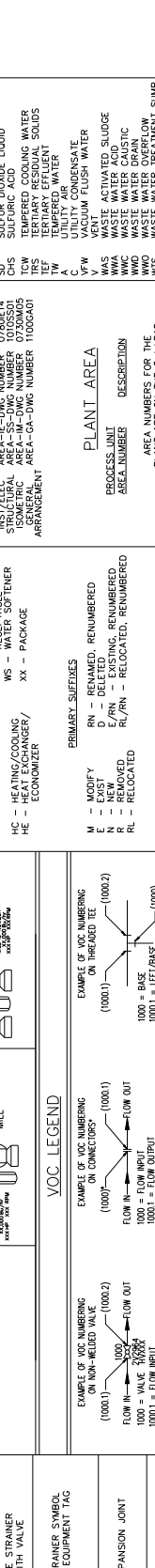
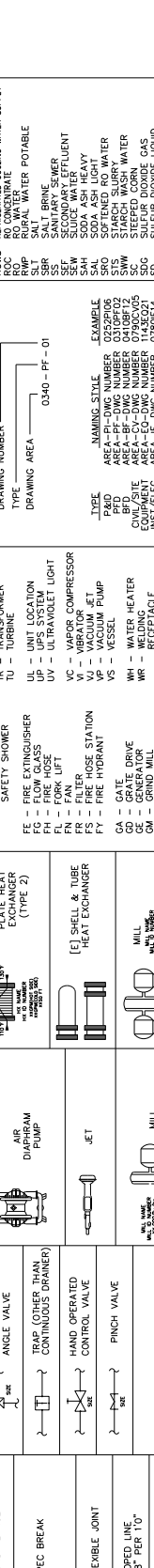
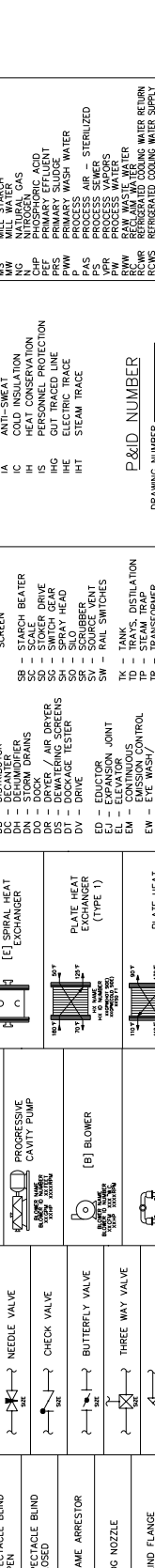
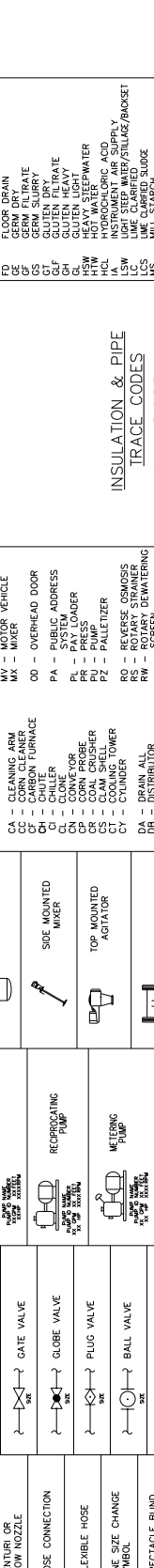
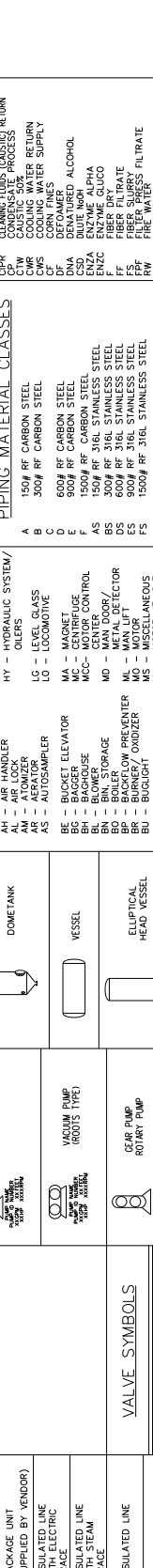
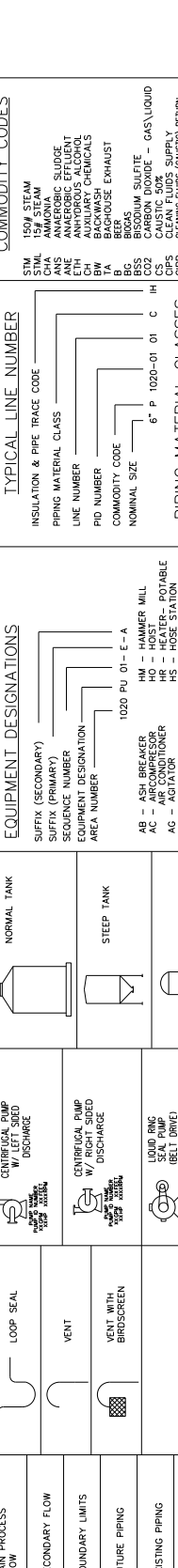

GENERAL SYMBOLS

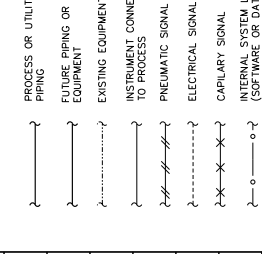

GENERAL SYMBOLS

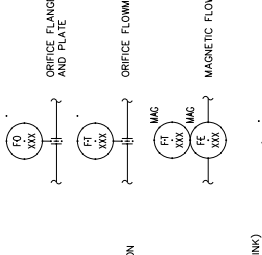

CONTROL VALVE ACTUATOR SYMBOLS

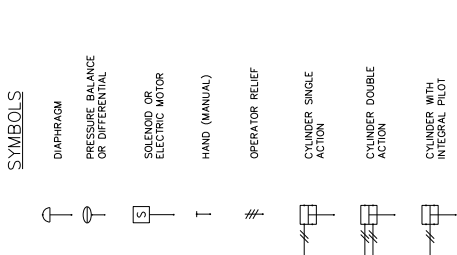

RELAY FUNCTION LIST

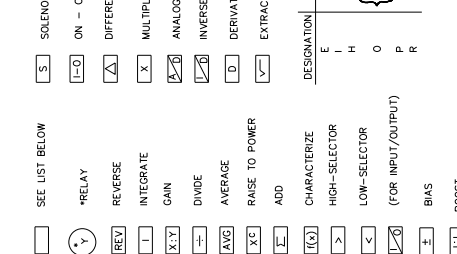

TYPICAL INSTRUMENT NUMBER

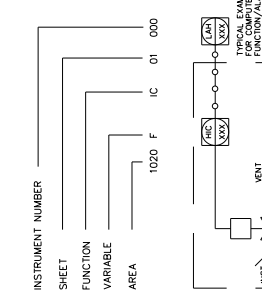

INSTRUMENT IDENTIFICATION

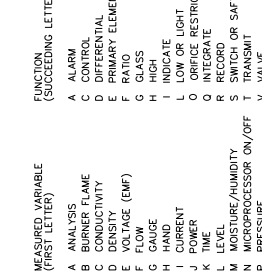

GENERAL IDENTIFICATION

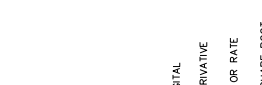

SELF-ACTUATED DEVICE

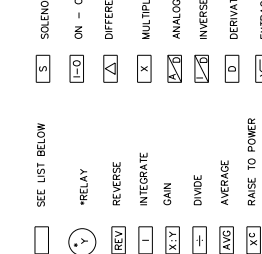

INSTRUMENT SYMBOLS

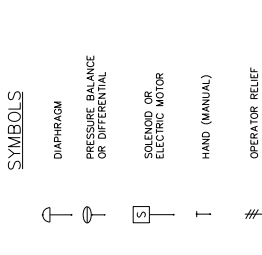

REMOTE-ACTUATED VALVES

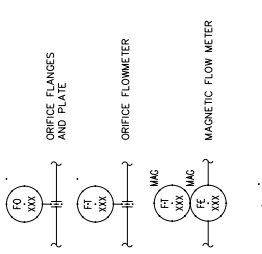

TYPICAL CONTROL FOR ALL ON/OFF VALVES FROM HONEYWELL DCS

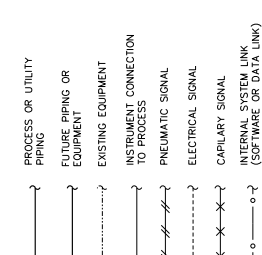

GENERAL NOTES

- VESEL TRIM LINE NUMBERS ETC. APPLIES TO VENTS, DRAINS, SOL. L.S. & LC COMM. ON THAT PARTICULAR PIECE OF EQUIPMENT.
- ALL VALVED VENTS AND DRAINS ARE 3/4" UNLESS NOTED OTHERWISE.
- ALL INSTRUMENTS TO ATMOSPHERE ARE PLUGGED OR BUNDLED AS DETERMINED BY PIPING MATERIAL SPECIFICATIONS.
- ALL CONTROL VALVES ARE FAIL OPEN UNLESS NOTED OTHERWISE.

ENGINEERING RECORD

| | |
|--------------|----------|
| DATE: | 02/17/11 |
| SCALE: | - NONE - |
| DRAWN BY: | DMK |
| CHECKED BY: | AKT |
| APPROVED BY: | |

PRELIMINARY

THIS DRAWING IS THE PROPERTY OF THE ARCHER DANIELS-MIDLAND CO. IT IS NOT TO BE REPRODUCED, COPIED, OR TRANSMITTED IN ANY FORM OR BY ANY MEANS WITHOUT PERMISSION OF AN AUTHORIZED REPRESENTATIVE OF THE COMPANY.

PIPING & INSTRUMENT DIAGRAM (PID)

INSTRUMENTATION SYMBOLS & NOTES
 PROCESS GAS PROJECT 1098881 COVER SHEET - B

PROJECT DATA

| | |
|---------------------|-------------|
| PROJECT DATA | |
| PROJECT NUMBER | D |
| PROCESS AREA | 1041-PD-00B |
| SEQUENTIAL REVISION | C |

ADDITIONAL INFORMATION

ADDITIONAL INFORMATION
 DRAWING NUMBER: 1041-PD-00B
 REVISION: C

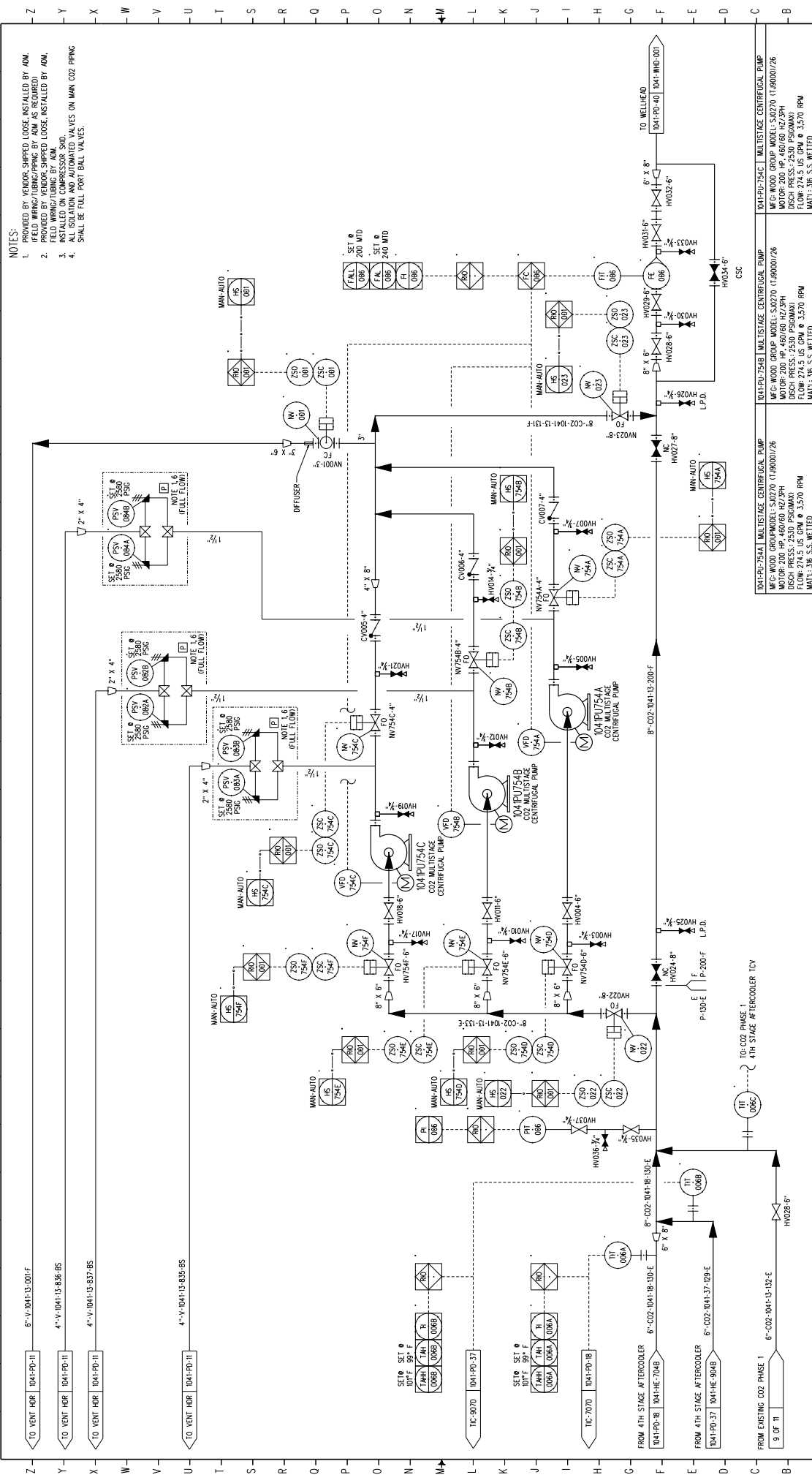

- NOTES:**
1. PROVIDED BY VENDOR, SHIPPED LOOSE, INSTALLED BY ADM.
 2. FIELD WRENCHING/TESTING BY ADM.
 3. INSTALLED ON COMPRESSOR SHD.
 4. ALL ISOLATION AND AUTOMATED VALVES ON MAIN CO2 PIPING SHALL BE FULL PORT BALL VALVES.

| DATE | NO. | REVISION | BY | CHKD | APPR. | DATE | NO. | REVISION |
|----------|-----|-------------------------|-----|------|-------|------|-----|----------|
| 04/18/11 | G | ISSUED FOR APPROVAL | DAN | JKT | JKT | | | |
| 03/25/11 | F | ISSUED FOR FINAL REVIEW | BSS | JKT | JKT | | | |
| 03/04/11 | E | ISSUED FOR BID | DAN | JKT | JKT | | | |
| 03/01/11 | D | ISSUED FOR APPROVAL | DAN | JKT | JKT | | | |
| 02/27/11 | C | ISSUED FOR APPROVAL | DAN | JKT | JKT | | | |
| 02/24/11 | B | ISSUED FOR REVIEW | DAN | JKT | JKT | | | |
| 10/04/10 | A | ISSUED FOR REVIEW | DAN | JKT | JKT | | | |

| DATE | NO. | REVISION | BY | CHKD | APPR. | DATE | NO. | REVISION |
|------|-----|----------|----|------|-------|------|-----|----------|
| | | | | | | | | |

| DRAWING STATUS | | ENGINEERING RECORD | |
|----------------|----------|--------------------|----------|
| DATE: | 10/05/10 | DATE: | 10/05/10 |
| SCALE: | NONE | DRAWN BY: | DAN |
| | | CHECKED BY: | JKT |
| | | APPROVED BY: | |

| PRELIMINARY | | | |
|---|--|--|--|
| THIS DRAWING IS THE PROPERTY OF THE ARCHER DANIELS-MIDLAND CO. IT IS NOT TO BE PRINTED, PHOTOCOPIED, REPRODUCED, OR TRANSMITTED IN ANY FORM OR BY ANY MEANS, WITHOUT PERMISSION OF AN AUTHORIZED REPRESENTATIVE OF THE COMPANY. | | | |

| PIPING & INSTRUMENT DIAGRAM (PID) | | | |
|---|---|---|---|
| 104-PD-754A MULTISTAGE CENTRIFUGAL PUMP | 104-PD-754B MULTISTAGE CENTRIFUGAL PUMP | 104-PD-754C MULTISTAGE CENTRIFUGAL PUMP | 104-PD-754E MULTISTAGE CENTRIFUGAL PUMP |
| WEG WOOD GROUP MODEL: S0270 (139000)/26 DISCH PRESS: 2530 PSIG(MAN) FLOW: 274.5 US GPM @ 3,570 RPM MATL: 316 S.S. WETTED | WEG WOOD GROUP MODEL: S0270 (139000)/26 DISCH PRESS: 2530 PSIG(MAN) FLOW: 274.5 US GPM @ 3,570 RPM MATL: 316 S.S. WETTED | WEG WOOD GROUP MODEL: S0270 (139000)/26 DISCH PRESS: 2530 PSIG(MAN) FLOW: 274.5 US GPM @ 3,570 RPM MATL: 316 S.S. WETTED | WEG WOOD GROUP MODEL: S0270 (139000)/26 DISCH PRESS: 2530 PSIG(MAN) FLOW: 274.5 US GPM @ 3,570 RPM MATL: 316 S.S. WETTED |

APPENDIX D

APPENDIX D – Area of Review Well Database

Contents:

Table D-1: List of 432 wells that are located inside the area of review. The proposed injection well is located in Sec 32 T17N R3E. The AoR covers an area, which can be described as a circular area, with approximate radius of 2 miles.

Figure D-1: A map showing these wells and the AoR. A full-size map is provided separately in this appendix.

A second table (Table D-2) contains a list of 3,746 wells located in 4 adjacent townships—T16N, R2E & R3E and T17N, R2E & R3E. All wells are located in Macon County and were identified by the process described in Section 5.3 of this application. Table D-2 is available as an electronic file that will be supplied in the electronic version of this UIC permit application.

Figure D-1. Known wells and boring within the AoR for the ADM IL-ICCS injection well.
 (Source: ISGS and ISWS well databases, current as of May 10, 2011).

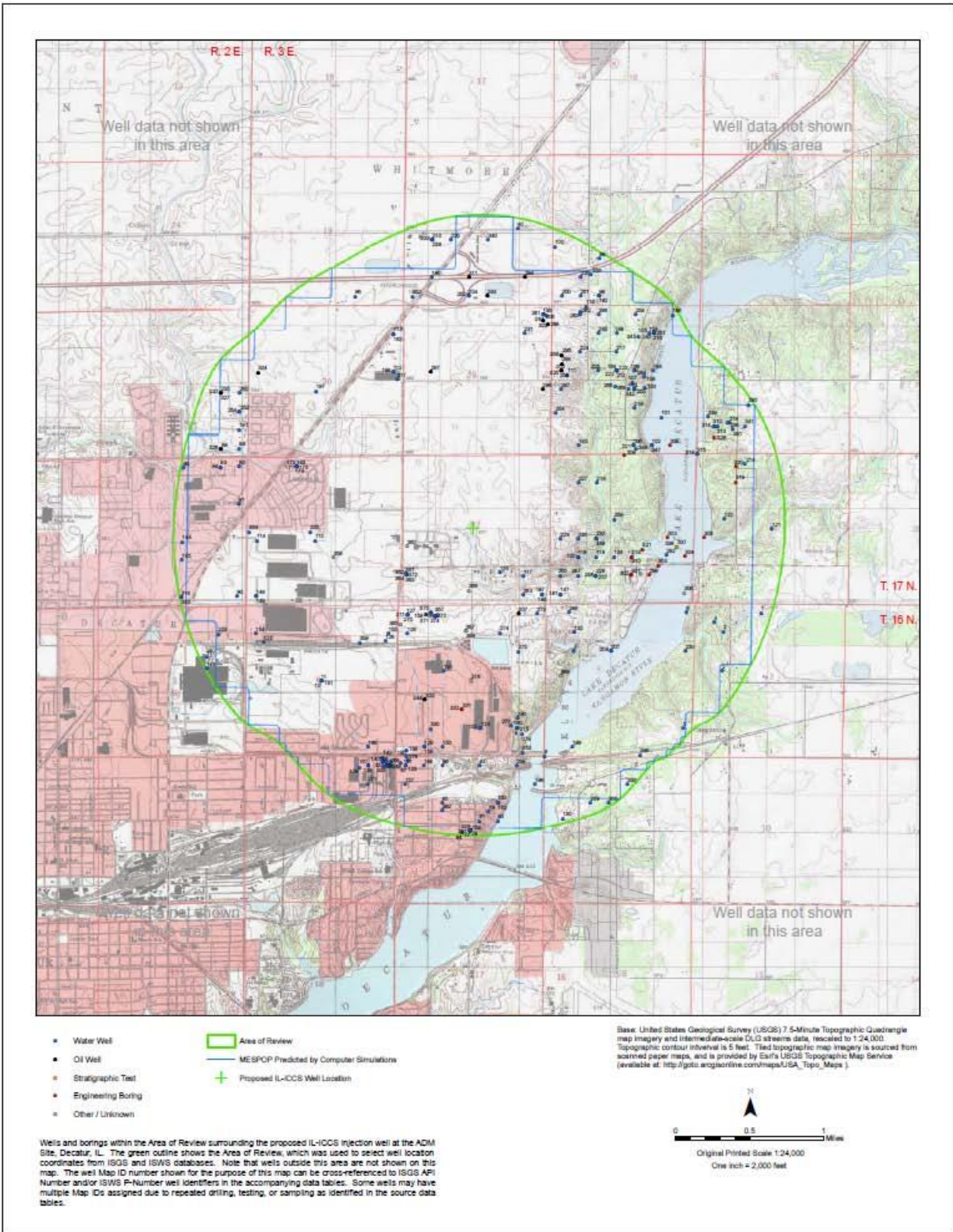

Table D-1. All known wells and borings inside the Area of Review (includes data from 2007 and 2011 searches, provided by Ed Mehnert & Chris Korose, ISGS, May 10, 2011)
Proposed IL-ICCS Injection Well Location: Lat. 39.88568 N, Long. -88.88879 W or Sec 32, T17N, R3E

| PERMIT MAP ID | API NUMBER | ISWSPNUM | DN 83_X | DN 83_Y | SECTION | TWP | TDIR | RNG | RDIR | owner | well number | driller | status | elev | ELEV REF | depth total last known | water from | depth open interval top | depth open interval bottom | cr pumping gpm | U16_X | U16_Y | abandoned | plugged | well type | date sealed | well use | inside_AoR |
|---------------|--------------|----------|------------|-----------|---------|-----|------|-----|------|--|-------------|---------------|--------|------|----------|------------------------|-----------------|-------------------------|----------------------------|----------------|-------------|-------------|-----------|---------|-----------|-------------|----------|------------|
| 1 | | 88163 | -88.851988 | 39.876055 | 3 16N | 03E | | | | ADOLPH DODDEK | | | | | | 10 | | | | | | | n | n | wd | | D | Y |
| 2 | 121152108200 | 88164 | -88.856777 | 39.872323 | 3 16 N | 3 | E | | | Melvin, David | | Beasley | WATER | 0 | 0 | 37 | sand and gravel | 22 | 25 | 0 | 341206.2691 | 4415236.293 | | | wd | | O | Y |
| 3 | | 88165 | -88.856742 | 39.876124 | 3 16N | 03E | | | | SAMUEL L. MOORE | | | | | | 14 | | | | | | | n | n | wd | | D | Y |
| 4 | 121150033400 | 88166 | -88.857915 | 39.877063 | 3 16 N | 3 | E | | | Brewer, Fred R. | | Lenz Tony | WATER | 0 | 0 | 94 | | 0 | 0 | 0 | 341119.8815 | 4415764.448 | | | wd | | O | Y |
| 5 | | 88167 | -88.861586 | 39.866567 | 4 16N | 03E | | | | RALPH MILLER | | | | | | | | | | | | | n | n | wd | | D | Y |
| 6 | | 88168 | -88.861461 | 39.877974 | 4 16N | 03E | | | | VICK ANDERSON | | T R HANKS | | | | 70 | | | | | | | n | n | wd | | D | Y |
| 7 | | 88169 | -88.875676 | 39.873907 | 4 16N | 03E | | | | DR WOLFE | | MASHBURN BROS | | | | 65 | | | | | | | n | n | wd | | D | Y |
| 8 | 121150033700 | 88177 | -88.879117 | 39.863561 | 5 16 N | 3 | E | | | Starr, Louise DECATUR PARK DIST (GOLF COURSE | | Lenz Tony | WATER | 0 | 0 | 64 | | 0 | 0 | 0 | 339275.1495 | 4414303.672 | | | wd | | O | Y |
| 9 | | 88178 | -88.882674 | 39.866299 | 5 16N | 03E | | | | GOLF COURSE | | G.C MASHBURN | | | | 101 | | | | | | | n | n | x | | IR | Y |
| 10 | | 88179 | -88.907625 | 39.87052 | 6 16N | 03E | | | | C.M BLANKENSHIP | | LENTZ | | | | 75 | | | | | | | n | n | wd | | D | Y |
| 11 | | 88180 | -88.907625 | 39.87052 | 6 16N | 03E | | | | JIM SHONDEL | | LENTZ | | | | 78 | | | | | | | n | n | wd | | D | Y |
| 12 | | 88197 | -88.888397 | 39.856152 | 8 16N | 03E | | | | DAVID L.HOPKINS | | LENTZ | | | | 55 | | | | | | | n | n | wd | | D | Y |
| 13 | | 88203 | -88.888397 | 39.856152 | 8 16N | 03E | | | | CHAS N DUNCAN | | TONY LENTZ | | | | 84 | | | | | | | n | n | wd | | D | Y |
| 14 | | 88204 | -88.888397 | 39.856152 | 8 16N | 03E | | | | CHAS M DUNCAN | | LENTZ | | | | 49 | | | | | | | n | n | wd | | D | Y |
| 15 | 121150037400 | 88205 | -88.888397 | 39.856152 | 8 16 N | 3 | E | | | Sullivan, Helen Ward | | Lenz Tony | WATER | 0 | 0 | 75 | | 0 | 0 | 0 | 338463.9816 | 4413498.019 | | | wd | | O | Y |
| 16 | 121150037100 | 88206 | -88.888397 | 39.856152 | 8 16 N | 3 | E | | | Raiford, T. S. | | Lenz Tony | WATER | 0 | 0 | 92 | | 0 | 0 | 0 | 338463.9816 | 4413498.019 | | | wd | | O | Y |
| 17 | | 88207 | -88.888397 | 39.856152 | 8 16N | 03E | | | | ROY CARR | | TONY LENTZ | | | | 87 | | | | | | | n | n | wd | | D | Y |
| 18 | 121150035800 | 88208 | -88.888397 | 39.856152 | 8 16 N | 3 | E | | | Blaeet, Roy | | Lenz Tony | WATER | 0 | 0 | 84 | | 0 | 0 | 0 | 338463.9816 | 4413498.019 | | | wd | | O | Y |
| 19 | | 88209 | -88.888397 | 39.856152 | 8 16N | 03E | | | | RUSSELL K SHAFER | | TONY LENTZ | | | | 110 | | | | | | | n | n | wd | | O | Y |
| 20 | | 88210 | -88.888397 | 39.856152 | 8 16N | 03E | | | | J E NICHOLS | | LENTZ | | | | 60 | | | | | | | n | n | wd | | D | Y |
| 21 | | 88212 | -88.888397 | 39.856152 | 8 16N | 03E | | | | CHARLES DUNCAN | | LENTZ | | | | 52 | | | | | | | n | n | wd | | D | Y |
| 22 | | 88214 | -88.888397 | 39.856152 | 8 16N | 03E | | | | E F LANGLEY | | LENTZ | | | | 45 | | | | | | | n | n | wd | | D | Y |
| 23 | 121150037200 | 88216 | -88.888397 | 39.856152 | 8 16 N | 3 | E | | | Rhodes, Howard | | Lenz Tony | WATER | 0 | 0 | 98 | | 0 | 0 | 0 | 338463.9816 | 4413498.019 | | | wd | | O | Y |

| PERMIT MAP ID | API NUMBER | ISWSPNUM | DD_N83_X | DD_N83_Y | SECTION | TWP | TDIR | RNG | RDIR | owner | well number | driller | status | elev | ELEV REF | depth total last | water from | depth open interval top | depth open interval bottom | cr pumping gpm | U16_X | U16_Y | abandoned | plugged | well type | date sealed | well use | inside_AorR |
|---------------|--------------|----------|------------|-----------|---------|-----|------|-------------------|------|--------------|-------------|---------|--------|------|----------|------------------|------------|-------------------------|----------------------------|----------------|-------------|-------------|-----------|---------|-----------|-------------|----------|-------------|
| 24 | 121150036300 | 88217 | -88.888397 | 39.856152 | 8 16 N | 3 | E | Gunter, John H. | | Lenitz Tony | | WATER | 0 | 90 | 0 | 0 | 0 | 0 | 0 | 0 | 338463.9816 | 4413498.019 | | | wd | | | Y |
| 25 | 121150035700 | 88218 | -88.888397 | 39.856152 | 8 16 N | 3 | E | Adams, Richard L. | | Lenitz Tony | | WATER | 0 | 90 | 0 | 0 | 0 | 0 | 0 | 0 | 338463.9816 | 4413498.019 | | | wd | | | Y |
| 26 | | 88220 | -88.888397 | 39.856152 | 8 16N | 03E | | LESTER GEER | | TONY LENTZ | | | | 85 | | | | | | | | | n | n | wd | | D | O |
| 27 | | 88221 | -88.888397 | 39.856152 | 8 16N | 03E | | JAMES H SCHUERMAN | | LENTZ | | | | 90 | | | | | | | | | n | n | wd | | D | O |
| 28 | | 88222 | -88.888397 | 39.856152 | 8 16N | 03E | | CLAUDE THOMPSON | | TONY LENTZ | | | | 110 | | | | | | | | | n | n | wd | | D | O |
| 29 | | 88223 | -88.888397 | 39.856152 | 8 16N | 03E | | MARIAN GODWIN | | TONY LENTZ | | | | 74 | | | | | | | | | n | n | wd | | D | O |
| 30 | | 88224 | -88.888397 | 39.856152 | 8 16N | 03E | | MARION GODWIN | | LENTZ | | | | 72 | | | | | | | | | n | n | wd | | D | O |
| 31 | | 88225 | -88.888397 | 39.856152 | 8 16N | 03E | | MARION GODWIN | | LENTZ | | | | 84 | | | | | | | | | n | n | wd | | D | O |
| 32 | | 88226 | -88.888397 | 39.856152 | 8 16N | 03E | | BEN KING | | LENTZ | | | | 73 | | | | | | | | | n | n | wd | | D | O |
| 33 | | 88227 | -88.888397 | 39.856152 | 8 16N | 03E | | BEN KING | | LENTZ | | | | 90 | | | | | | | | | n | n | wd | | D | O |
| 34 | | 88228 | -88.888397 | 39.856152 | 8 16N | 03E | | BEN KING | | LENTZ | | | | 83 | | | | | | | | | n | n | wd | | D | O |
| 35 | | 88229 | -88.888397 | 39.856152 | 8 16N | 03E | | HILL | | LENTZ | | | | 81 | | | | | | | | | n | n | wd | | D | O |
| 36 | | 88230 | -88.888397 | 39.856152 | 8 16N | 03E | | BEN KING | | LENTZ | | | | 83 | | | | | | | | | n | n | wd | | D | O |
| 37 | | 88232 | -88.888397 | 39.856152 | 8 16N | 03E | | BEN KING | | LENTZ | | | | 87 | | | | | | | | | n | n | wd | | D | O |
| 38 | | 88233 | -88.888397 | 39.856152 | 8 16N | 03E | | ROARICK | | LENTZ | | | | 35 | | | | | | | | | n | n | wd | | D | O |
| 39 | | 88234 | -88.888397 | 39.856152 | 8 16N | 03E | | MARION GODWIN | | LENTZ | | | | 85 | | | | | | | | | n | n | wd | | D | O |
| 40 | | 88235 | -88.888397 | 39.856152 | 8 16N | 03E | | BEN KING | | LENTZ | | | | 70 | | | | | | | | | n | n | wd | | D | O |
| 41 | | 88236 | -88.888397 | 39.856152 | 8 16N | 03E | | JACK RUSS | | LENTZ | | | | 85 | | | | | | | | | n | n | wd | | D | O |
| 42 | | 88237 | -88.888397 | 39.856152 | 8 16N | 03E | | BEN KING | | LENTZ | | | | 52 | | | | | | | | | n | n | wd | | D | O |
| 43 | | 88238 | -88.888397 | 39.856152 | 8 16N | 03E | | MARION GODWIN | | LENTZ | | | | 87 | | | | | | | | | n | n | wd | | D | O |
| 44 | | 88239 | -88.888397 | 39.856152 | 8 16N | 03E | | MATTIOTA | | LENTZ | | | | 80 | | | | | | | | | n | n | wd | | D | O |
| 45 | | 88240 | -88.888397 | 39.856152 | 8 16N | 03E | | BEN KING | | LENTZ | | | | 75 | | | | | | | | | n | n | wd | | D | O |
| 46 | | 88241 | -88.888397 | 39.856152 | 8 16N | 03E | | MARION GODWIN | | SPANGLER HTS | | | | 87 | | | | | | | | | n | n | wd | | D | O |
| 47 | | 88242 | -88.888397 | 39.856152 | 8 16N | 03E | | J C VOGEL | | LENTZ | | | | 73 | | | | | | | | | n | n | wd | | D | O |

| PERMIT MAP ID | API NUMBER | ISWSPNUM | DD_N83_X | DD_N83_Y | SECTION | TWP | TDIR | RNG | RDIR | owner | well number | driller | status | elev | ELEV REF | depth total last known | water from | depth open interval top | depth open interval bottom | cr pumping gpm | U16_X | U16_Y | abandoned | plugged | well type | date sealed | well use | inside_AoR |
|---------------|------------|----------|------------|-----------|---------|-----|------|-----|------|-----------------------|-------------|---------|--------|------|----------|------------------------|------------|-------------------------|----------------------------|----------------|-------|-------|-----------|---------|-----------|-------------|----------|------------|
| 48 | | 88243 | -88.888397 | 39.856152 | 8 16N | 03E | | | | MARION GODWIN | | LENTZ | | | | 79 | | | | | | | n | n | wd | | O | Y |
| 49 | | 88244 | -88.888397 | 39.856152 | 8 16N | 03E | | | | MARION GODWIN | | LENTZ | | | | 79 | | | | | | | n | n | wd | | O | Y |
| 50 | | 88245 | -88.888397 | 39.856152 | 8 16N | 03E | | | | MARION GODWIN | | LENTZ | | | | 85 | | | | | | | n | n | wd | | O | Y |
| 51 | | 88246 | -88.888397 | 39.856152 | 8 16N | 03E | | | | MARION GODWIN | | LENTZ | | | | 74 | | | | | | | n | n | wd | | O | Y |
| 52 | | 88247 | -88.888397 | 39.856152 | 8 16N | 03E | | | | CARL T GEORGE | | LENTZ | | | | 61 | | | | | | | n | n | wd | | O | Y |
| 53 | | 88248 | -88.888397 | 39.856152 | 8 16N | 03E | | | | RAY LITTLE | | LENTZ | | | | 95 | | | | | | | n | n | wd | | O | Y |
| 54 | | 88249 | -88.888397 | 39.856152 | 8 16N | 03E | | | | KOSSIECK | | LENTZ | | | | 82 | | | | | | | n | n | wd | | O | Y |
| 55 | | 88250 | -88.888397 | 39.856152 | 8 16N | 03E | | | | SUFFERN | | LENTZ | | | | 82 | | | | | | | n | n | wd | | O | Y |
| 56 | | 88251 | -88.888397 | 39.856152 | 8 16N | 03E | | | | SPANGLER | | LENTZ | | | | 85 | | | | | | | n | n | wd | | O | Y |
| 57 | | 88252 | -88.888397 | 39.856152 | 8 16N | 03E | | | | TOMMY THOMPSON | | LENTZ | | | | 104 | | | | | | | n | n | wd | | O | Y |
| 58 | | 88253 | -88.888397 | 39.856152 | 8 16N | 03E | | | | M GODWIN | | LENTZ | | | | 86 | | | | | | | n | n | wd | | O | Y |
| 59 | | 88254 | -88.888397 | 39.856152 | 8 16N | 03E | | | | MARION GODWIN | | LENTZ | | | | 88 | | | | | | | n | n | wd | | O | Y |
| 60 | | 88255 | -88.888397 | 39.856152 | 8 16N | 03E | | | | ED STOLLY | | LENTZ | | | | 84 | | | | | | | n | n | wd | | O | Y |
| 61 | | 88256 | -88.888397 | 39.856152 | 8 16N | 03E | | | | WILLARD JENKINS | | LENTZ | | | | 75 | | | | | | | n | n | wd | | O | Y |
| 62 | | 88257 | -88.888397 | 39.856152 | 8 16N | 03E | | | | ERNEST E SPINNER | | LENTZ | | | | 60 | | | | | | | n | n | wd | | O | Y |
| 63 | | 88258 | -88.888397 | 39.856152 | 8 16N | 03E | | | | HANKS | | LENTZ | | | | | | | | | | | n | n | wd | | O | Y |
| 64 | | 88259 | -88.888397 | 39.856152 | 8 16N | 03E | | | | | | LENTZ | | | | 45 | | | | | | | n | n | wd | | O | Y |
| 65 | | 88260 | -88.888397 | 39.856152 | 8 16N | 03E | | | | DON DEFOREST | | LENTZ | | | | 64 | | | | | | | n | n | wd | | O | Y |
| 66 | | 88261 | -88.888397 | 39.856152 | 8 16N | 03E | | | | WILLIAM N MALONE | | LENTZ | | | | 76 | | | | | | | n | n | wd | | O | Y |
| 67 | | 88262 | -88.888397 | 39.856152 | 8 16N | 03E | | | | WAYNE & GENE CAMPBELL | | LENTZ | | | | 80 | | | | | | | n | n | wd | | O | Y |
| 68 | | 88263 | -88.888397 | 39.856152 | 8 16N | 03E | | | | ILLINI REALTY | | LENTZ | | | | 58 | | | | | | | n | n | wd | | O | Y |
| 69 | | 88264 | -88.888397 | 39.856152 | 8 16N | 03E | | | | THOMAS HALL | | LENTZ | | | | 93 | | | | | | | n | n | wd | | O | Y |
| 70 | | 88265 | -88.888397 | 39.856152 | 8 16N | 03E | | | | DON ETNIER | | LENTZ | | | | 83 | | | | | | | n | n | wd | | O | Y |
| 71 | | 88266 | -88.888397 | 39.856152 | 8 16N | 03E | | | | RUSSELL OBRIEN | | LENTZ | | | | 48 | | | | | | | n | n | wd | | O | Y |

| PERMIT MAP ID | API NUMBER | ISWSPNUM | DN .N83 .X | DN .N83 .Y | SECTION | TWP | TDIR | RNG | RDIR | owner | well number | driller | status | elev | ELEV REF | depth total last known | water from | depth open interval top | depth open interval bottom | cr pumping gpm | U16 X | U16 Y | abandoned | plugged | well type | date sealed | well use | inside_Aor | |
|---------------|--------------|----------|------------|------------|---------|-----|------|--------------------|------|-------------------------|-------------|---------|--------|------|----------|------------------------|-----------------|-------------------------|----------------------------|----------------|-------------|-------------|-------------|---------|-----------|-------------|----------|------------|--|
| 72 | | 88267 | -88.888397 | 39.856152 | 8 16N | 03E | | COLE | | LENTZ | | | | | | 76 | | | | | | | n | n | wd | O | Y | | |
| 73 | | 88268 | -88.888397 | 39.856152 | 8 16N | 03E | | GEORGE M PRUST | | LENTZ | | | | | | 52 | | | | | | | n | n | wd | O | Y | | |
| 74 | | 88269 | -88.888397 | 39.856152 | 8 16N | 03E | | GLEN STEWART | | LENTZ | | | | | | 76 | | | | | | | n | n | wd | O | Y | | |
| 75 | | 88270 | -88.888397 | 39.856152 | 8 16N | 03E | | DOYLE WILLIAMS | | LENTZ | | | | | | 40 | | | | | | | n | n | wd | O | Y | | |
| 76 | | 88271 | -88.888397 | 39.856152 | 8 16N | 03E | | YORK | | LENTZ | | | | | | 102 | | | | | | | n | n | wd | O | Y | | |
| 77 | | 88272 | -88.888397 | 39.856152 | 8 16N | 03E | | CARL GEORGE | | LENTZ | | | | | | 74 | | | | | | | n | n | wd | O | Y | | |
| 78 | | 88273 | -88.888397 | 39.856152 | 8 16N | 03E | | DURBIN | | | | | | | | 38 | | | | | | | n | n | wd | O | Y | | |
| 79 | 121150086400 | 88274 | -88.886074 | 39.858003 | 8 16 N | 3 E | | Scammahom, W. W. | 1 | Hanks, T. R. | | | WATER | 0 | | 84 | sand and gravel | 79 | 84 | 25 | 338667.0431 | 4413699.28 | | | wd | | Y | | |
| 80 | | 88277 | -88.884882 | 39.857119 | 8 16N | 03E | | J F WILMETH | | T R HANKS | | | | | | 60 | | | | | | | n | n | wd | O | Y | | |
| 81 | | 88282 | -88.887235 | 39.857079 | 8 16N | 03E | | HARRY BOUCH | | L R BURT | | | | | | 74 | | | | | | | n | n | wd | O | Y | | |
| 82 | 121150036800 | 88283 | -88.888397 | 39.856152 | 8 16 N | 3 E | | Penn, Thomas | | Lenz, Tony | | | WATER | 0 | | 40 | | | | | 0 | 338463.9816 | 4413498.019 | | | wd | | Y | |
| 83 | | 88284 | -88.887338 | 39.862511 | 8 16N | 03E | | N CARNELL | | MASHBURN BROS | | | | | | 102 | | | | | | | n | n | wd | O | Y | | |
| 84 | 121150036900 | 88296 | -88.889387 | 39.85592 | 8 16 N | 3 E | | Perkins, Donald D. | | Lenz, Tony | | | WATER | 0 | | 93 | | | | | 0 | 338378.7457 | 4413474.057 | | | wd | | Y | |
| 85 | | 88300 | -88.891198 | 39.858806 | 8 16N | 03E | | J HANKS | | TONY LENTZ | | | | | | 80 | | | | | | | n | n | wd | O | Y | | |
| 86 | | 88301 | -88.892045 | 39.862431 | 8 16N | 03E | | GLACKEN | | T R HANKS | | | | | | 228 | | | | | | | n | n | wd | O | Y | | |
| 87 | 121150037000 | 88311 | -88.896752 | 39.862347 | 8 16 N | 3 E | | Powell, Doc. | | Woolen Brothers | | | WATER | 0 | | 108 | sand and gravel | 104 | 108 | 8 | 337763.8314 | 4414200.79 | | | wd | | Y | | |
| 88 | | 89002 | -88.918714 | 39.893105 | 25 17N | 02E | | JOHN HARRISON | | ASHMORE | | | | | | 81 | | | | | | | n | n | wd | O | Y | | |
| 89 | | 89003 | -88.921072 | 39.893037 | 25 17N | 02E | | BENSHAW SCHOOL | | | | | | | | 82 | | | | | | | n | n | x | SC | Y | | |
| 90 | | 89400 | -88.918563 | 39.878592 | 36 17N | 02E | | EDGAR ALEXANDER | | | | | | | | 23 | | | | | | | n | n | wd | O | Y | | |
| 91 | | 89401 | -88.918655 | 39.887662 | 36 17N | 02E | | J F BURDINE | | | | | | | | 40 | | | | | | | n | n | wd | O | Y | | |
| 92 | | 89402 | -88.918682 | 39.891289 | 36 17N | 02E | | JOSEPH BLOIR | | WEBB | | | | | | 18 | | | | | | | n | n | wd | O | Y | | |
| 93 | | 89403 | -88.921044 | 39.891224 | 36 17N | 02E | | JOHN ALBERTS | | | | | | | | 18 | | | | | | | n | n | wd | O | Y | | |
| 94 | | 89404 | -88.921044 | 39.891224 | 36 17N | 02E | | BILL MASON | | MASHBURN BROS | | | | | | 85 | | | | | | | n | n | wd | O | Y | | |
| 95 | | 89405 | -88.925276 | 39.891087 | 36 17N | 02E | | O E SLOAN | | | | | | | | 13 | | | | | | | n | n | wd | O | Y | | |
| 96 | 121152194500 | 89447 | -88.904385 | 39.908234 | 19 17 N | 3 E | | Duncan, Tim | 1 | Mashburn, Grover C. Jr. | | | WATER | 0 | | 127 | sand | 120 | 127 | 15 | 337219.51 | 4419308.09 | | | wd | | Y | | |

| PERMIT MAP ID | API NUMBER | ISWSPNUM | DD_N83_X | DD_N83_Y | SECTION | TWP | TDIR | RNG | RDIR | owner | well number | driller | status | elev | ELEV REF | depth total last | water from | depth open interval top | depth open interval bottom | cr pumping gpm | U16_X | U16_Y | abandoned | plugged | well type | date sealed | well use | inside_AoR |
|---------------|--------------|----------|------------|------------|---------|-----|------|-----|------|---|-------------|-------------------------|--------|------|----------|------------------|---------------|-------------------------|----------------------------|----------------|-------------|-------------|-----------|---------|-----------|-------------|----------|------------|
| 97 | 121152191300 | 89450 | -88.883907 | 39.915219 | 20 | 17 | N | 3 | E | Swearingin, Rick | 1 | Mashburn, Bruce E. | WATER | 64 | 0 | GL | 134 | 129 | 134 | 15 | 339886.3772 | 4420046.279 | | wd | wd | | Y | |
| 98 | 121152116900 | 89453 | -88.873433 | 39.9108788 | 21 | 17 | N | 3 | E | Dickey, Jack | | Beasley | WATER | 0 | 0 | 40 | gravel | 15 | 32 | 0 | 339866.6444 | 4419313.601 | | wd | wd | | Y | |
| 99 | | 89455 | -88.873461 | 39.912492 | 21 | 17N | | 03E | | D H NIXON | | MASHBURN BROS | | | | 96 | | | | | | n | n | wd | | O | Y | |
| 100 | 121152124900 | 89459 | -88.879154 | 39.913524 | 21 | 17 | N | 3 | E | Vamer, Cecil | 1 | Mashburn Brothers | WATER | 0 | 0 | 121 | sand | 110 | 121 | 15 | 339888.6715 | 4419849.572 | | wd | wd | | Y | |
| 101 | 121152191500 | 89497 | -88.865171 | 39.897033 | 28 | 17 | N | 3 | E | Smalley, Gary | 1 | Mashburn, Grover C. Jr. | WATER | 0 | 0 | 105 | sand | 96 | 105 | 10 | 340545.6337 | 4417994.021 | | wd | wd | | Y | |
| 102 | 121152124800 | 89498 | -88.866325 | 39.894279 | 28 | 17 | N | 3 | E | Radiang, Tom | | Beasley | WATER | 0 | 0 | 78 | gravel | 24 | 74 | 0 | 340040.5826 | 4417690.392 | | wd | wd | | Y | |
| 103 | 121150102100 | 89499 | -88.867367 | 39.899688 | 28 | 17 | N | 3 | E | Taylor, George | 1 | Hanks, T. R. | WATER | 0 | 0 | 86 | sand & gravel | 77 | 80 | 15 | 340364.4656 | 4418312.627 | | wd | wd | | Y | |
| 104 | | 89500 | -88.866362 | 39.905214 | 28 | 17N | | 03E | | R E KINZER 1 | | WOOLLEN BROS | | | | 103 | | | | | | n | n | wd | | O | Y | |
| 105 | 121150100200 | 89501 | -88.866906 | 39.905286 | 28 | 17 | N | 3 | E | Kinzer, R. E. | 2 | Woollett Earl D | WATER | 0 | 0 | 91 | sand | 84 | 91 | 10 | 340416.4523 | 4418913.195 | | wd | wd | | Y | |
| 106 | | 89502 | -88.866864 | 39.894231 | 28 | 17N | | 03E | | RONALD C ALSTAD | | | | | | 112 | | | | | | n | n | wd | | O | Y | |
| 107 | 121150103500 | 89503 | -88.868947 | 39.900365 | 28 | 17 | N | 3 | E | Klingler, Herb | 1 | Hanks, T. R. | WATER | 0 | 0 | 82 | sand | 74 | 77 | 6 | 340230.5423 | 4418370.619 | | wd | wd | | Y | |
| 108 | | 89504 | -88.868866 | 39.901531 | 28 | 17N | | 03E | | HAROLD CONWAY 1 | | T R HANKS | | | | 105 | | | | | | n | n | wd | | O | Y | |
| 109 | 121150100700 | 89505 | -88.867519 | 39.900094 | 28 | 17 | N | 3 | E | Conway, Harold | 1 | Hanks, T. R. | WATER | 67 | T | 0 | M | 103 | 94 | 25 | 340353.9594 | 4418431.889 | | wd | wd | | Y | |
| 110 | 121150093200 | 89506 | -88.87503 | 39.907745 | 28 | 17 | N | 3 | E | Federal Housing | 1 | Mashburn, B.E. | WATER | 65 | 5 | GL | 125 | 118 | 125 | 12 | 339727.6991 | 4419200.695 | | wd | wd | | Y | |
| 111 | 121150096400 | 89507 | -88.877294 | 39.90128 | 17 | N | 3 | E | E | Conway, M. D. | 1 | Hanks, T. R. | WATER | 0 | 0 | 110 | gray sand | 105 | 108 | 10 | 339518.424 | 4418456.074 | | wd | wd | | Y | |
| 112 | 121150102000 | 89508 | -88.899348 | 39.900935 | 30 | 17N | | 03E | | RAY H CRISTIAN | | T R HANKS | | | | 113 | | | | | | n | n | wd | | O | Y | |
| 113 | 121150092800 | 89509 | -88.899427 | 39.904631 | 30 | 17 | N | 3 | E | Rockhold, Max | | Dement Ray Well Co | WATER | 0 | 0 | 112 | sand | 107 | 112 | 6 | 337634.8224 | 4418899.13 | | wd | wd | | Y | |
| 114 | | 89510 | -88.916216 | 39.884093 | 31 | 17N | | 03E | | MAX ROCKHOLD | | RAY DEMENT | | | | 115 | | | | | | n | n | wd | | O | Y | |
| 115 | | 89511 | -88.908824 | 39.88423 | 31 | 17N | | 03E | | MAX ROCKHOLD | | RAY DEMENT | | | | 117 | | | | | | n | n | wd | | O | Y | |
| 116 | | 89512 | -88.885283 | 39.881461 | 32 | 17N | | 03E | | CLARK | | LENTZ | | | | 71 | | | | | | n | n | wd | | O | Y | |
| 117 | | 89513 | -88.862264 | 39.881173 | 32 | 17N | | 03E | | ACE DROLL | | MASHBURN BROS | | | | 45 | | | | | | n | n | wd | | O | Y | |
| 118 | | 89515 | -88.873103 | 39.883211 | 33 | 17N | | 03E | | GILBERT GRUBBS | | MASHBURN BROS | | | | 80 | | | | | | n | n | wd | | O | Y | |
| 119 | | 89516 | -88.875368 | 39.88316 | 33 | 17N | | 03E | | CAMPBELL | | MASHBURN | | | | 98 | | | | | | n | n | wd | | O | Y | |
| 120 | | 89517 | -88.875368 | 39.88316 | 33 | 17N | | 03E | | JAMES NEESE | | MASHBURN BROS | | | | 84 | | | | | | n | n | wd | | O | Y | |
| 121 | | 89518 | -88.850844 | 39.886326 | 34 | 17N | | 03E | | BOONE HERM BOEHM (ROBERTA RUPERT) | | LENTZ | | | 95 | | | | | | n | n | wd | | O | Y | | |
| 122 | | 89522 | -88.856945 | 39.887168 | 34 | 17N | | 03E | | MASHBURN BROS | | MASHBURN BROS | | | | 55 | | | | | | n | n | wd | | O | Y | |

| PERMIT MAP ID | API NUMBER | ISWSPNUM | DN .N83 .X | DN .N83 .Y | SECTION | TWP | TDIR | RNG | RDIR | owner | well number | driller | status | elev | ELEV REF | depth total last | water from | depth open interval top | depth open interval bottom | cr pumping gpm | U16 X | U16 Y | abandoned | plugged | well type | date sealed | well use | inside_Aor |
|---------------|--------------|----------|------------|------------|---------|-----|------|-----|------|---|-------------|---------------------|--------|------|----------|------------------|----------------------|-------------------------|----------------------------|----------------|-------------|-------------|-----------|---------|-----------|-------------|----------|------------|
| 123 | | 89763 | -88.896752 | 39.862347 | 8 16N | 03E | | | | AMERICAN BAKERY | | BRUCE MASHBURN | | | | 98 | | | | | | n | n | wc | | IC | Y | |
| 124 | | 89773 | -88.887381 | 39.86621 | 5 16N | 03E | | | | ARCHER DANIELS MIDLAND CO | | MASHBURN BROS | | | | 111 | | | | | | n | n | wc | | IC | Y | |
| 125 | 121152241700 | 89792 | -88.915063 | 39.874175 | 6 16 N | 3 | E | | | Caterpillar Tractor TH | 1 | Burt, Luther | WTST | 0 | 0 | 110 | | 0 | 0 | 0 | 336225.6599 | 4415547.092 | Y | | wc | | Y | |
| 126 | 121152241800 | 89793 | -88.899596 | 39.874528 | 6 16 N | 3 | E | | | Caterpillar Tractor T | 2 | Burt, Luther | WTST | 0 | 0 | 125 | | 0 | 0 | 0 | 337549.3035 | 4415558.033 | Y | | wc | | Y | |
| 127 | | 89813 | -88.896904 | 39.87715 | 5 16N | 03E | | | | DECATUR BOTTLING CO | | G C MASHBURN | | | | 70 | | | | | | n | n | wc | | IC | Y | |
| 128 | | 89814 | -88.896888 | 39.875295 | 5 16N | 03E | | | | DECATUR BOTTLING CO | | MASHBURN BROS | | | | 71 | | | | | | n | n | wc | | IC | Y | |
| 129 | | 89815 | -88.894422 | 39.86422 | 5 16N | 03E | | | | DECATUR BOTTLING CO | | MASHBURN | | | | 70 | | | | | | n | n | wc | | IC | Y | |
| 130 | 121150037700 | 89854 | -88.876613 | 39.85747 | 9 16 N | 3 | E | | | Decatur Park District | | Woolien Brothers | WATER | 0 | 0 | 78 | sandy clay & sand | 0 | 0 | 0 | 339475.1381 | 4413623.08 | | wc | | IC | Y | |
| 131 | 121152180200 | 89859 | -88.892142 | 39.871694 | 5 16 N | 3 | E | | | Ecoff Trucking, Inc. | | Reynolds, Joseph R. | WATER | 0 | 0 | 70 | | 10 | 70 | 0 | 337986.8227 | 4415846.242 | | wc | | Y | | |
| 132 | | 89869 | -88.875688 | 39.875784 | 4 16N | 03E | | | | DECATUR PARK DIST | | | | | | 102 | | | | | | n | n | x | | PK | Y | |
| 133 | | 89875 | -88.864916 | 39.85893 | 8 16N | 03E | | | | DISABLED VETERANS | | MASHBURN BROS | | | | 37 | | | | | | n | n | wd | | O | Y | |
| 134 | | 89905 | -88.870835 | 39.883263 | 33 17N | 03E | | | | HIGH COOK CAN CO | | MASHBURN BROS | | | | 77 | | | | | | n | n | wc | | IC | Y | |
| 135 | | 89921 | -88.925888 | 39.882014 | 36 17N | 02E | | | | I & S DRY WALL | | MASHBURN BROS | | | | 17 | | | | | | n | n | wc | | IC | Y | |
| 136 | 121150034000 | 89932 | -88.898651 | 39.862674 | 7 16 N | 3 | E | | | Spencer Kellogg & Sons, Inc. | 1 | Burt, Luther R. | WATER | 0 | 0 | 97 | | 0 | 0 | 440 | 337602.1635 | 4414240.536 | | wc | | Y | | |
| 137 | 121150034100 | 89933 | -88.899185 | 39.862672 | 7 16 N | 3 | E | | | Spencer Kellogg & Sons, Inc. | 2 | Burt, Luther R. | WATER | 0 | 0 | 96 | | 0 | 0 | 0 | 337556.481 | 4414241.285 | | wc | | Y | | |
| 138 | 121150034500 | 89934 | -88.899543 | 39.862668 | 7 16 N | 3 | E | | | Spencer Kellogg & Sons, Inc. | 6 | Burt, Luther R. | WATER | 0 | 0 | 88 | | 0 | 0 | 0 | 337525.8486 | 4414241.492 | | wc | | Y | | |
| 139 | | 89935 | -88.901512 | 39.8623 | 7 16N | 03E | | | | SPENCER KELLOGG & SONS INC | | | | | | 87 | | | | | | n | n | wc | | IC | Y | |
| 140 | 121150034200 | 89936 | -88.899722 | 39.862666 | 7 16 N | 3 | E | | | Spencer Kellogg & Sons, Inc. | 3 | Burt, Luther R. | WATER | 0 | 0 | 97 | | 0 | 0 | 350 | 337510.5324 | 4414241.596 | | wc | | Y | | |
| 141 | 121150034300 | 89937 | -88.899536 | 39.862254 | 7 16 N | 3 | E | | | Spencer Kellogg & Sons, Inc. | 4 | Burt, Luther R. | WTST | 0 | 0 | 115 | | 0 | 0 | 0 | 337525.4705 | 4414195.528 | Y | wc | | Y | | |
| 142 | 121150034400 | 89938 | -88.899733 | 39.863108 | 7 16 N | 3 | E | | | Spencer Kellogg & Sons, Inc. | 5 | Burt, Luther R. | WATER | 0 | 0 | 99 | | 0 | 0 | 0 | 337510.6345 | 4414290.677 | | wc | | Y | | |
| 143 | | 89944 | -88.911382 | 39.891452 | 31 17N | 03E | | | | LARKDALE SWIM CLUB | | MASHBURN BROS | | | | 98 | | | | | | n | n | x | | IR | Y | |
| 144 | | 89976 | -88.925705 | 39.883827 | 36 17N | 02E | | | | MORGAN SASH & DOOR SHELLSBARGER GRAIN PROD CO | | T R HANKS | | | | 122 | | | 10.00 | | | n | n | wc | | IC | Y | |
| 145 | | 90047 | -88.899123 | 39.862318 | 7 16N | 03E | | | | VET ADMIN | | L R BURT | | | | 95 | | | | | | n | n | wc | | IC | Y | |
| 146 | | 90112 | -88.90154 | 39.864127 | 6 16N | 03E | | | | VET ADMIN | | DEMENT | | | | 54 | | | | | | n | n | wd | | O | Y | |
| 147 | | 90113 | -88.877539 | 39.879467 | 33 17N | 03E | | | | VET ADMIN | | DEMENT | | | | 85 | | | | | | n | n | wd | | O | Y | |
| 148 | | 90129 | -88.916165 | 39.878647 | 31 17N | 03E | | | | W S O Y RADIO STATION | | LEONARD NEWBERRY | | | | 37 | | | | | | n | n | wc | | IC | Y | |
| 149 | | 90130 | -88.916165 | 39.878647 | 31 17N | 03E | | | | W S O Y RADIO STATION | | LEONARD NEWBERRY | | | | 87 | | | | | | n | n | wc | | IC | Y | |
| 150 | 121152218000 | 190939 | -88.892069 | 39.864264 | 5 16 N | 3 | E | | | Morris, Jerry | | Reynolds, Joseph R. | WATER | 0 | 0 | 62 | | 0 | 0 | 0 | 338168.9175 | 4414405.082 | | wd | | Y | | |

| PERMIT MAP ID | API NUMBER | ISWSPNUM | DN 83.X | DN 83.Y | SECTION | TWP | TDIR | RNG | RDIR | owner | well number | driller | status | elev | ELEV REF | depth total last | water from | depth open interval top | depth open interval bottom | cr pumping gpm | U16.X | U16.Y | abandoned | plugged | well type | date sealed | well use | inside_Aor |
|---------------|--------------|----------|------------|------------|---------|-----|------|-----|------|---|-------------|-------------------------|--------|------|----------|------------------|--------------------|-------------------------|----------------------------|----------------|-------------|-------------|-----------|---------|-----------|-------------|----------|------------|
| 177 | 121150018900 | 201362 | -88.922297 | 39.872594 | 1 16 N | 2 | E | 2 | E | Ralston Purina Co Test SHELLBARGER GRAIN PROD | 3 | Layne Western Co., Inc. | WTST | 0 | 0 | 114 | | 0 | 0 | 0 | 335603.1974 | 4415384.89 | Y | wc | | Y | | |
| 178 | | 201380 | -88.899123 | 39.862318 | 7 16N | 03E | | | | BURT | | | | | | 95 | | | | | | n | n | wc | | IC | Y | |
| 179 | 121150035600 | 201476 | -88.902578 | 39.862093 | 7 16 N | 3 | E | 3 | E | A. E. Staley Mfg. Co. test | 29 | Griffy, Cecil D. | WTST | 0 | 0 | 96 | | 0 | 0 | 0 | 337264.879 | 4414183.191 | Y | wc | | Y | | |
| 180 | 121150037300 | 201478 | -88.896691 | 39.863255 | 8 16 N | 3 | E | 3 | E | A. E. Staley Mfg. Co. test | 30 | Griffy, Cecil D. | WTST | 0 | 0 | 109 | | 0 | 0 | 0 | 337771.1886 | 4414301.466 | Y | wc | | Y | | |
| 181 | | 201542 | -88.877539 | 39.879467 | 33 17N | 03E | | | | VET ADMIN | | DEMENT | | | | 85 | | | | | | n | n | wc | | N | Y | |
| 182 | 121152203300 | 210125 | -88.871019 | 39.901494 | 28 17 N | 3 | E | 3 | E | Smalley, Gary | 1 | Mashburn, Grover C. Jr. | WATER | 0 | 0 | 110 | sand | 100 | 110 | 10 | 340056.0293 | 4418499.647 | | wd | | Y | | |
| 183 | 121152203300 | 210153 | -88.886873 | 39.899707 | 28 17 N | 3 | E | 3 | E | Grigg, Ron | 1 | Mashburn, Grover C. Jr. | WATER | 0 | 0 | 121 | sand | 108 | 121 | 15 | 340252.4385 | 4418297.092 | | wd | | Y | | |
| 184 | 121152208000 | 210385 | -88.871019 | 39.901494 | 28 17 N | 3 | E | 3 | E | Allen, Raymond E. | 1 | Mashburn, Grover C. Jr. | WATER | 0 | 0 | 105 | sand | 99 | 105 | 15 | 340056.0293 | 4418499.647 | | wd | | Y | | |
| 185 | 121152209000 | 218728 | -88.875586 | 39.894088 | 28 17 N | 3 | E | 3 | E | Vanhkamp, Steve | | Luttrell, Gerald Dean | WATER | 0 | 0 | 82 | fine sand | 75 | 82 | 0 | 339648.3276 | 4417685.781 | | wd | | Y | | |
| 186 | 121152210000 | 218721 | -88.864016 | 39.907065 | 28 17 N | 3 | E | 3 | E | Vanhkamp, Frederick | | Luttrell, Gerald Dean | WATER | 0 | 0 | 73 | | 0 | 0 | 0 | 340667.6286 | 4419105.5 | | wd | | Y | | |
| 187 | 121152212000 | 218729 | -88.87985 | 39.879411 | 32 17 N | 3 | E | 3 | E | Sebens, Gary | | Luttrell, Gerald Dean | WATER | 0 | 0 | 38 | yellow sand | 12 | 17 | 0 | 339249.468 | 4416064.317 | | wd | | Y | | |
| 188 | 121152218100 | 221433 | -88.894399 | 39.862388 | 8 16 N | 3 | E | 3 | E | Anchor Inn | | Luttrell, Gerald Dean | WATER | 0 | 0 | 54 | sand & gravel | 48 | 54 | 0 | 337965.2019 | 4414201.072 | | wc | | Y | | |
| 189 | 121152287000 | 229739 | -88.87105 | 39.905149 | 28 17 N | 3 | E | 3 | E | Doty, Bob | | Mashburn, Grover C. Jr. | WATER | 0 | 0 | 86 | sand | 81 | 86 | 0 | 340061.881 | 4418905.404 | | wd | | Y | | |
| 190 | | 231047 | -88.894731 | 39.910252 | 20 17N | 03E | | | | WILLIAM BROWN | | LUTTRELL | | | | 62 | | | | | | n | n | wd | | D | Y | |
| 191 | 121152219200 | 231496 | -88.918756 | 39.894925 | 25 17 N | 2 | E | 2 | E | Woodroff, Herb | | Luttrell, Gerald Dean | WATER | 0 | 0 | 60 | | 0 | 0 | 0 | 335959.2958 | 4417857.102 | | wd | | Y | | |
| 192 | 121152203000 | 231497 | -88.873433 | 39.908788 | 21 17 N | 3 | E | 3 | E | Meier, Emery | 1 | Luttrell, Gerald Dean | WATER | 0 | 0 | 78 | sand | 71 | 78 | 15 | 339866.6444 | 4419313.601 | | wd | | Y | | |
| 193 | 121152236400 | 243223 | -88.880475 | 39.906846 | 29 17 N | 3 | E | 3 | E | Hanna, William H. | 1 | Ready, Dale | WATER | 0 | 0 | 136 | | 0 | 0 | 10 | 339260.1441 | 4419110.697 | | wd | | Y | | |
| 194 | 121152236300 | 243225 | -88.866349 | 39.901568 | 28 17 N | 3 | E | 3 | E | Smalley, Gary | 1 | Mashburn, Grover C. Jr. | WATER | 0 | 0 | 101 | sand | 96 | 101 | 12 | 340455.441 | 4418499.505 | | wd | | Y | | |
| 195 | 121152236600 | 261218 | -88.87985 | 39.879411 | 32 17 N | 3 | E | 3 | E | Silies, Anna | | Luttrell, Gerald Dean | WATER | 0 | 0 | 56 | gray sand & gravel | 51 | 56 | 0 | 339249.468 | 4416064.317 | | wd | | Y | | |
| 196 | 121152252700 | 275751 | -88.88024 | 39.860824 | 8 16 N | 3 | E | 3 | E | Pice, Lee | | Mashburn, Robert | WATER | 0 | 0 | 91 | sand | 47 | 91 | 12 | 339172.6984 | 4414001.89 | | wd | | Y | | |
| 197 | 121152221100 | 280757 | -88.909091 | 39.898992 | 30 17 N | 3 | E | 3 | E | Schwarze, R.D. | | Luttrell, Gerald Dean | WATER | 0 | 0 | 33 | | 0 | 0 | 0 | 336795.0573 | 4418279.725 | | wd | | Y | | |
| 198 | 121152236500 | 285488 | -88.899348 | 39.900935 | 30 17 N | 3 | E | 3 | E | Jan-San Supply | | Luttrell, Gerald Dean | WATER | 0 | 0 | 48 | yellow sand | 40 | 48 | 0 | 337632.8485 | 4418488.733 | | wc | | Y | | |
| 199 | 121152258400 | 289868 | -88.875623 | 39.864528 | 4 16 N | 3 | E | 3 | E | Kiger, Dave | | Luttrell, James | WATER | 0 | 0 | 30 | | 0 | 0 | 0 | 339576.271 | 4414404.728 | | wd | | Y | | |
| 200 | 121152268900 | 293158 | -88.87814 | 39.908727 | 21 17 N | 3 | E | 3 | E | Hawthorne Homes Inc. | | Luttrell, James | WATER | 0 | 0 | 70 | | 0 | 0 | 0 | 339464.1412 | 4419315.285 | | wc | | Y | | |
| 201 | 121152269000 | 297600 | -88.875788 | 39.908756 | 21 17 N | 3 | E | 3 | E | Lane, Richard E. | | Luttrell, James | WATER | 0 | 0 | 61 | | 0 | 0 | 0 | 339665.2612 | 4419314.276 | | wd | | Y | | |
| 202 | 121152269200 | 297602 | -88.878026 | 39.9301382 | 28 17 N | 3 | E | 3 | E | Kelly, Franklin Jr. | | Luttrell, James | WATER | 0 | 0 | 82 | | 0 | 0 | 0 | 339456.7364 | 4418499.791 | | wd | | Y | | |
| 203 | 121152198100 | 297743 | -88.920871 | 39.874869 | 1 16 N | 2 | E | 2 | E | Sams, Lloyd | | Luttrell, Gerald Dean | WATER | 0 | 0 | 65 | sand | 44 | 47 | 0 | 335730.5882 | 4415634.79 | | wd | | Y | | |
| 204 | 121152264600 | 299527 | -88.889979 | 39.908508 | 20 17 N | 3 | E | 3 | E | Shur Co. | | Mashburn, Robert | WATER | 0 | 0 | 145 | dry | 0 | 0 | 0 | 338451.6109 | 4419312.334 | | wc | | Y | | |
| 205 | 121152271600 | 303144 | -88.870833 | 39.85912 | 9 16 N | 3 | E | 3 | E | Russell, Florence | | Luttrell, James | WATER | 0 | 0 | 45 | | 0 | 0 | 0 | 339973.4232 | 4413795.861 | | wd | | Y | | |

| PERMIT MAP ID | API NUMBER | ISWSPNUM | DD_N83_X | DD_N83_Y | SECTION | TWP | TDIR | RNG | RDIR | owner | well number | driller | status | elev | ELEV REF | depth total last known | water from | depth open interval top | depth open interval bottom | cr pumping gpm | U16_X | U16_Y | abandoned | plugged | well type | date sealed | well use | inside_Aor |
|---------------|--------------|----------|------------|-----------|---------|-----|------|-----|------|------------------------------|-------------|------------------------|--------|------|----------|------------------------|---------------|-------------------------|----------------------------|----------------|-------------|-------------|-----------|---------|-----------|-------------|----------|------------|
| 206 | 121152273800 | 303944 | -88.880475 | 39.906846 | 29 | 17 | N | 3 | E | Smalley, Gary | | Mashburn, Robert | WATER | 0 | 0 | 101 | sand | 98 | 101 | 12 | 339260.1441 | 4419110.697 | | wd | | Y | | |
| 207 | 121152273200 | 304871 | -88.87095 | 39.873995 | 4 | 16 | N | 3 | E | Beck, Matthew A. | | Luttrell, James | WATER | 0 | 0 | 19 | | 0 | 0 | 0 | 339997.9869 | 4415447.17 | | wd | | Y | | |
| 208 | 121152273300 | 304872 | -88.87095 | 39.873995 | 4 | 16 | N | 3 | E | Blinnick, Amy | | Luttrell, James | WATER | 0 | 0 | 43 | | 0 | 0 | 0 | 339997.9869 | 4415447.17 | | wd | | Y | | |
| 209 | 121152279600 | 309131 | -88.873175 | 39.859097 | 9 | 16 | N | 3 | E | Kopetz Mfg., Inc. | | Reynolds Well Drilling | WATER | 0 | 0 | 69 | sand gravel | 65 | 69 | 0 | 339773.0277 | 4413797.504 | | wc | | Y | | |
| 210 | 121152281100 | 311483 | -88.89476 | 39.913928 | 20 | 17 | N | 3 | E | Omni Erection, Inc./Reynolds | | Mashburn, Robert | WATER | 0 | 0 | 136 | sand | 120 | 136 | 12 | 338056.6917 | 4419822.613 | | wc | | Y | | |
| 211 | 121152283500 | 312842 | -88.896904 | 39.87715 | 5 | 16 | N | 3 | E | Acher Daniels Midland | 3 East | Dowell, S.L. | WATER | 0 | 0 | 130 | | 0 | 0 | 1000 | 337785.7144 | 4415844.18 | | wc | | Y | | |
| 212 | 121152284500 | 314763 | -88.871019 | 39.901494 | 28 | 17 | N | 3 | E | Kosenski, Robert | | Mashburn, Robert | WATER | 0 | 0 | 110 | sand | 100 | 110 | 15 | 340056.0293 | 4418499.647 | | wd | | Y | | |
| 213 | 121152284600 | 314787 | -88.866857 | 39.883314 | 33 | 17 | N | 3 | E | Yaegel, Carl | | Gaza, John Edward | WATER | 0 | 0 | 98 | top of casing | 67 | 98 | 15 | 340223.1724 | 4416477.305 | | wd | | Y | | |
| 214 | 121152284700 | 314790 | -88.854497 | 39.892669 | 34 | 17 | N | 3 | E | Maples, Henry | | Gaza, John Edward | WATER | 0 | 0 | 92 | top of casing | 60 | 92 | 15 | 341448.157 | 4417490.616 | | wd | | Y | | |
| 215 | 121152283400 | 319507 | -88.882674 | 39.866299 | 5 | 16 | N | 3 | E | Archer Daniels Midland | 4 | Dowell, S.L. | WATER | 0 | 0 | 120 | | 0 | 0 | 1000 | 338977.2954 | 4414613.99 | | wc | | Y | | |
| 216 | 121152287400 | 322494 | -88.866362 | 39.905214 | 28 | 17 | N | 3 | E | Meador, James & Susan | 1 | Sims, R. Marc Jr. | WATER | 0 | 0 | 107 | sand | 99 | 107 | 10 | 340462.7894 | 4418904.231 | | wd | | Y | | |
| 217 | 121152287500 | 323334 | -88.871035 | 39.903321 | 28 | 17 | N | 3 | E | Grubbs, Curtis | | Gaza, John Edward | WATER | 0 | 0 | 83 | top of casing | 40 | 83 | 18 | 340058.9111 | 4418702.471 | | wd | | Y | | |
| 218 | 121152287700 | 323336 | -88.873217 | 39.89049 | 33 | 17 | N | 3 | E | Walker, Tim | | Gaza, John Edward | WATER | 0 | 0 | 55 | top of casing | 30 | 55 | 15 | 339842.4992 | 4417282.155 | | wd | | Y | | |
| 219 | 121152291200 | 325421 | -88.868661 | 39.89788 | 28 | 17 | N | 3 | E | Cheatham, Arthur & Gloria | | Gaza, John Edward | WATER | 0 | 0 | 112 | top of casing | 58 | 112 | 10 | 340249.2205 | 4418094.276 | | wd | | Y | | |
| 220 | 121152290200 | 326095 | -88.892394 | 39.913979 | 20 | 17 | N | 3 | E | Oasis Truckstop | | Mashburn, Robert | WATER | 0 | 0 | 134 | sand | 118 | 134 | 20 | 338258.0459 | 4419923.984 | | wc | | Y | | |
| 221 | 121152290000 | 326575 | -88.868664 | 39.894231 | 28 | 17 | N | 3 | E | Radley, Alvira M. | | Balding, Shane | WATER | 0 | 0 | 102 | top of casing | 57 | 102 | 10 | 340242.5401 | 4417689.203 | | wd | | Y | | |
| 222 | 121152296300 | 331769 | -88.871019 | 39.901494 | 28 | 17 | N | 3 | E | McCarty, Ron | | Luttrell, James | WATER | 0 | 0 | 95 | | 0 | 0 | 0 | 340056.0293 | 4418499.647 | | wd | | Y | | |
| 223 | 121152297100 | 334269 | -88.871019 | 39.901494 | 28 | 17 | N | 3 | E | McCarty, Ron | | Mashburn, Robert | DRYP | 0 | 0 | 140 | dry hole | 0 | 0 | 0 | 340056.0293 | 4418499.647 | Y | Y | | Y | | |
| 224 | 121152298000 | 334337 | -88.875716 | 39.90325 | 28 | 17 | N | 3 | E | Critchlow, Frank | | Mashburn, Robert | WATER | 0 | 0 | 97 | sand | 94 | 97 | 12 | 339658.5756 | 4418702.986 | | wd | | Y | | |
| 225 | 121152298300 | 334340 | -88.873356 | 39.901457 | 28 | 17 | N | 3 | E | Braford, Stanley | | Balding, Shane | WATER | 0 | 0 | 104 | top of casing | 60 | 104 | 18 | 339856.152 | 4418499.729 | | wd | | Y | | |
| 226 | 121152298800 | 334884 | -88.875804 | 39.910608 | 21 | 17 | N | 3 | E | Williams, Robert & Sheri | | Mashburn, Robert | WATER | 0 | 0 | 123 | sand | 117 | 123 | 12 | 339668.2129 | 4419519.676 | | wd | | Y | | |
| 227 | 121152303200 | 336745 | -88.875518 | 39.890442 | 33 | 17 | N | 3 | E | Reidelberger, Bruce | | Balding, Shane | WATER | 0 | 0 | 82 | sand | 77 | 82 | 30 | 339645.6423 | 4417280.957 | | wd | | Y | | |
| 228 | 121152307200 | 342220 | -88.873073 | 39.88139 | 33 | 17 | N | 3 | E | Kenwood, Don | 1 | S & J Well Drilling | WATER | 0 | 0 | 60 | sand | 50 | 60 | 40 | 339833.629 | 4416271.809 | | wd | | Y | | |
| 229 | 121152307300 | 342222 | -88.877681 | 39.88493 | 33 | 17 | N | 3 | E | Klepzig, Aaron | 1 | S & J Well Drilling | WATER | 0 | 0 | 105 | sand | 95 | 105 | 25 | 339447.834 | 4416673.018 | | wd | | Y | | |
| 230 | 121152307400 | 342223 | -88.861502 | 39.874171 | 4 | 16 | N | 3 | E | Beck, Matthew | 1 | S & J Well Drilling | WATER | 0 | 0 | 40 | sand | 25 | 40 | 40 | 340806.43 | 4415449.827 | | wd | | Y | | |
| 231 | 121152306700 | 342505 | -88.88281 | 39.904962 | 29 | 17 | N | 3 | E | Smalley, Jeff | 1 | S & J Well Drilling | WATER | 0 | 0 | 102 | sand | 96 | 102 | 15 | 339056.1291 | 4418905.781 | | wd | | Y | | |
| 232 | 121152306000 | 343558 | -88.87313 | 39.88503 | 33 | 17 | N | 3 | E | Bail, David | 1 | Mashburn, Robert | WATER | 0 | 0 | 82 | sand | 72 | 82 | 12 | 339837.2275 | 4416675.946 | | wd | | Y | | |
| 233 | 121152304000 | 344381 | -88.89476 | 39.913928 | 20 | 17 | N | 3 | E | TCR Systems | | S & J Well Drilling | WATER | 0 | 0 | 121 | sand | 117 | 121 | 12 | 338055.6917 | 4419922.613 | | wc | | Y | | |
| 234 | 121152308700 | 345167 | -88.873073 | 39.88139 | 33 | 17 | N | 3 | E | Schaub, Jerry & Donna | 1 | Mashburn, Robert | WATER | 0 | 0 | 91 | sand | 72 | 91 | 12 | 339833.629 | 4416271.809 | | wd | | Y | | |
| 235 | 121152311200 | 347854 | -88.921195 | 39.898492 | 25 | 17 | N | 2 | E | Ricker, Greg & Tonya | | S & J Well Drilling | DRYP | 0 | 0 | 120 | dry hole | 0 | 0 | 0 | 335759.2824 | 4418257.521 | Y | Y | | Y | | |

| PERMIT MAP ID | API NUMBER | ISWSPNUM | DD_N83_X | DD_N83_Y | SECTION | TWP | TDIR | RNG | RDIR | owner | well number | driller | status | elev | ELEV REF | depth total last | water from | depth open interval top | depth open interval bottom | cr pumping gpm | U16_X | U16_Y | abandoned | plugged | well type | date sealed | well use | inside_Aor |
|---------------|--------------|----------|------------|------------|---------|-----|------|-----|------|----------------------------|-------------|-----------------------|--------|------|----------|------------------|---------------|-------------------------|----------------------------|----------------|-------------|-------------|-----------|---------|-----------|-------------|----------|------------|
| 236 | 121152312700 | 348705 | -88.875405 | 39.884979 | 33 | 17 | N | 3 | E | Bali, Larry & Rebecca | | S & J Well Drilling | WATER | 0 | 0 | 104 | sand | 74 | 104 | 15 | 339842.5713 | 4416674.368 | | wd | | Y | | |
| 237 | 121152313000 | 348706 | -88.921195 | 39.889492 | 25 | 17 | N | 2 | E | Ricker, Greg & Tawnya | 1 | Skinner, Todd | WATER | 0 | 0 | 39 | sand & gravel | 15 | 17 | 0 | 335759.2824 | 4418257.521 | | wd | | Y | | |
| 238 | 121152312600 | 348708 | -88.882831 | 39.862594 | 8 | 16 | N | 3 | E | Pugh, Brad | | S & J Well Drilling | WATER | 0 | 0 | 40 | sand | 8 | 40 | 60 | 338972.3088 | 4414202.663 | | wd | | Y | | |
| 239 | 121152313200 | 349760 | -88.89476 | 39.913928 | 20 | 17 | N | 3 | E | McLeod Express | 1 | Mashburn, Robert | WATER | 0 | 0 | 135 | sand | 131 | 135 | 30 | 338055.6917 | 4419822.613 | | wc | | Y | | |
| 240 | 121152313200 | 349889 | -88.866362 | 39.905214 | 28 | 17 | N | 3 | E | Ewing, David | | Mashburn, Robert | WATER | 0 | 0 | 105 | sand | 100 | 105 | 7 | 340462.7894 | 4418904.231 | | wd | | Y | | |
| 241 | | 352640 | -88.898761 | 39.86241 | 7 | 16N | | 03E | | ARCHER DANIELS MIDLAND CO. | | ANDREW L. WIESENHOFER | | | | 24 | | | | | | Y | X | 2 | 12/23/200 | Y | | |
| 242 | | 352641 | -88.898761 | 39.86241 | 7 | 16N | | 03E | | ARCHER DANIELS MIDLAND CO. | | ANDREW L. WIESENHOFER | | | | 17 | | | | | | Y | X | 2 | 12/23/200 | Y | | |
| 243 | | 352642 | -88.898761 | 39.86241 | 7 | 16N | | 03E | | ARCHER DANIELS MIDLAND CO. | | ANDREW L. WIESENHOFER | | | | 23 | | | | | | Y | X | 2 | 12/23/200 | Y | | |
| 244 | | 352643 | -88.898761 | 39.86241 | 7 | 16N | | 03E | | ARCHER DANIELS MIDLAND CO. | | ANDREW L. WIESENHOFER | | | | 26 | | | | | | Y | X | 2 | 12/23/200 | Y | | |
| 245 | | 352644 | -88.898761 | 39.86241 | 7 | 16N | | 03E | | ARCHER DANIELS MIDLAND CO. | | ANDREW L. WIESENHOFER | | | | 21 | | | | | | Y | X | 2 | 12/23/200 | Y | | |
| 246 | | 352645 | -88.898761 | 39.86241 | 7 | 16N | | 03E | | ARCHER DANIELS MIDLAND CO. | | ANDREW L. WIESENHOFER | | | | 30 | | | | | | Y | X | 2 | 12/23/200 | Y | | |
| 247 | | 352646 | -88.898761 | 39.86241 | 7 | 16N | | 03E | | ARCHER DANIELS MIDLAND CO. | | ANDREW L. WIESENHOFER | | | | 28 | | | | | | Y | X | 2 | 12/23/200 | Y | | |
| 248 | | 352647 | -88.898761 | 39.86241 | 7 | 16N | | 03E | | ARCHER DANIELS MIDLAND CO. | | ANDREW L. WIESENHOFER | | | | 13 | | | | | | Y | X | 2 | 12/23/200 | Y | | |
| 249 | | 352648 | -88.898761 | 39.86241 | 7 | 16N | | 03E | | ARCHER DANIELS MIDLAND CO. | | ANDREW L. WIESENHOFER | | | | 17 | | | | | | Y | X | 2 | 12/23/200 | Y | | |
| 250 | | 352649 | -88.898761 | 39.86241 | 7 | 16N | | 03E | | ARCHER DANIELS MIDLAND CO. | | ANDREW L. WIESENHOFER | | | | 17 | | | | | | Y | X | 2 | 12/23/200 | Y | | |
| 251 | | 354403 | -88.866343 | 39.905361 | 28 | 17N | | 03E | | DAVID EWING | | ROBERT MASHBURN | | | | 104 | | | | | | Y | Y | wd | 6/30/2003 | O | | |
| 252 | 121152265000 | 355542 | -88.889979 | 39.908508 | 20 | 17 | N | 3 | E | Shur Company | | Luttrell, James | WATER | 0 | 0 | 25 | | 0 | 0 | 0 | 338451.6109 | 4419312.334 | | wc | | Y | | |
| 253 | 121152317100 | 358056 | -88.918798 | 39.896741 | 25 | 17 | N | 2 | E | Trostle, Lisa | 1 | Skinner, Todd | WATER | 0 | 0 | 45 | sand & gravel | 11 | 23 | 0 | 335960.0363 | 4418058.754 | | wd | | Y | | |
| 254 | 121152317000 | 358273 | -88.918798 | 39.896741 | 25 | 17 | N | 2 | E | Trostle, Lisa | | Mashburn, Robert | DRYP | 0 | 0 | 125 | dry hole | 0 | 0 | 0 | 335960.0363 | 4418058.754 | Y | Y | | Y | | |
| 255 | 121152316500 | 359986 | -88.886873 | 39.899707 | 28 | 17 | N | 3 | E | Elliot, John | | S & J Well Drilling | WATER | 0 | 0 | 115 | sand | 100 | 115 | 0 | 340252.4385 | 4418297.092 | | wd | | Y | | |
| 256 | 121152316600 | 359987 | -88.878026 | 39.901382 | 28 | 17 | N | 3 | E | McCarty, Ronald W. | | S & J Well Drilling | WATER | 0 | 0 | 78 | sand | 70 | 78 | 5 | 339456.7364 | 4418499.791 | | wd | | Y | | |
| 257 | 121152319300 | 361043 | -88.873073 | 39.88139 | 33 | 17 | N | 3 | E | Morris, Steve | | S & J Well Drilling | WATER | 0 | 0 | 62 | sand | 50 | 62 | 20 | 339833.629 | 4416271.809 | | wd | | Y | | |
| 258 | 121152318300 | 361730 | -88.868719 | 39.9307005 | 28 | 17 | N | 3 | E | Traugher, William | 2 | Sims, R. Marc Jr. | WATER | 0 | 0 | 108 | sand | 104 | 108 | 6 | 340265.4606 | 4419107.244 | | wd | | Y | | |
| 259 | 121152319100 | 365451 | -88.870877 | 39.896901 | 33 | 17 | N | 3 | E | Johnson, Matt | | S & J Well Drilling | WATER | 0 | 0 | 90 | sand | 70 | 90 | 40 | 340034.2337 | 4416879.587 | | wd | | Y | | |
| 260 | 121152319400 | 367211 | -88.918841 | 39.898557 | 25 | 17 | N | 2 | E | New Day Community Church | 1 | Skinner, Todd | WATER | 0 | 0 | 80 | sand & gravel | 66 | 70 | 0 | 335960.6916 | 4418260.408 | | wc | | Y | | |
| 261 | 121152323000 | 370672 | -88.860475 | 39.906849 | 29 | 17 | N | 3 | E | Smalley, Jeff | | Mashburn, Robert | WATER | 0 | 0 | 102 | sand | 99 | 102 | 12 | 339260.1511 | 4419111.03 | | wd | | Y | | |
| 262 | 121152323300 | 370676 | -88.875765 | 39.906918 | 28 | 17 | N | 3 | E | Thornton, Bill | 2 | Mashburn, Robert | WATER | 0 | 0 | 102 | sand | 99 | 102 | 7 | 339862.9407 | 4419110.219 | | wd | | Y | | |

| PERMIT MAP ID | API NUMBER | ISWSPNUM | DN 83.X | DN 83.Y | SECTION | TWP | TDIR | RNG | RDIR | owner | well number | driller | status | elev | ELEV REF | depth total last | water from | depth open interval top | depth open interval bottom | cr pumping gpm | U16.X | U16.Y | abandoned | plugged | well type | date sealed | well use | inside_Aor |
|---------------|--------------|----------|------------|-----------|---------|-----|------|-----|------|---------------------------|-------------|-------------------------|--------|------|----------|------------------|--------------------|-------------------------|----------------------------|----------------|-------------|-------------|-----------|---------|-----------|-------------|----------|------------|
| 263 | | 370750 | -88.875788 | 39.907233 | 28 17N | | | 03E | | BILL THORNTON | | ROBERT MASHBURN | | | | 102 | | | | | | | Y | Y | wd | 5/21/2005 | D | |
| 264 | | 371827 | -88.880103 | 39.90677 | 29 17N | | | 03E | | JEFF SMALLEY | | ROBERT MASHBURN | | | | 45 | | | | | | | Y | Y | wd | 7/9/2005 | D | |
| 265 | 121152235500 | 372368 | -88.877564 | 39.881289 | 33 17 N | | | 3 | E | Klepzig, Aaron | | S & J Well Drilling | WATER | 0 | | 97 | sand | 90 | 98 | 15 | 339447.6332 | 4416268.697 | Y | Y | wd | | D | |
| 266 | | 372894 | -88.871122 | 39.899921 | 28 17N | | | 03E | | MIKE CAMPBELL | | ROBERT MASHBURN | | | | 81 | | | | | | | Y | Y | wd | 9/9/2005 | O | |
| 267 | 121152329100 | 374988 | -88.875327 | 39.881341 | 33 17 N | | | 3 | E | Walker, Cody | | S & J Well Drilling | WATER | 0 | | 95 | sand | 85 | 95 | 0 | 339640.763 | 4416270.415 | Y | Y | wd | | O | |
| 268 | | 375862 | -88.888761 | 39.86241 | 7 16N | | | 03E | | ADM - WEST PLANT | | ROBERT MASHBURN | | | | 85 | | | | | | Y | Y | wd | 11/21/200 | IC | | |
| 269 | 121152332900 | 383584 | -88.869444 | 39.899722 | 28 17 N | | | 3 | E | Allen, D. Scott | | S & J Well Drilling | WATER | | | 112 | sand | 98 | 112 | 15 | 340186.5586 | 4418300.137 | | | wd | | Y | |
| 270 | 121152208800 | 402770 | -88.896904 | 39.87715 | 5 16 N | | | 3 | E | ADM Corn Sweeteners | 5 | Grosch, Wayne A. | WATER | 0 | | 90 | | | | | | | | | wc | | Y | |
| 271 | 121152207200 | 402771 | -88.901478 | 39.860489 | 7 16 N | | | 3 | E | ADM Corn Sweeteners | | Grosch, Wayne A. | WATER | 0 | | 125 | | 0 | 0 | 0 | 337355.1942 | 4414003.146 | | | wc | | Y | |
| 272 | 121152207100 | 402772 | -88.899123 | 39.862318 | 7 16 N | | | 3 | E | ADM Corn Sweeteners | | Grosch, Wayne A. | WATER | 0 | | 94 | | 0 | 0 | 0 | 337560.9493 | 4414201.879 | | | wc | | Y | |
| 273 | 121152207000 | 402773 | -88.890433 | 39.877651 | 5 16 N | | | 3 | E | ADM Corn Sweeteners | 1 | Grosch, Wayne A. | WATER | 0 | | 110 | | 0 | 0 | 0 | 339195.265 | 4415858.909 | | | wc | | Y | |
| 274 | 121152207400 | 402775 | -88.885122 | 39.875574 | 5 16 N | | | 3 | E | ADM Corn Sweeteners | 2 | Grosch, Wayne A. | WATER | 0 | | 114 | | 0 | 0 | 0 | 338789.6297 | 4415647.917 | | | wc | | Y | |
| 275 | 121152206900 | 402777 | -88.882748 | 39.873762 | 5 16 N | | | 3 | E | ADM Corn Sweeteners | 3 | Grosch, Wayne A. | WATER | 0 | | 80 | | 0 | 0 | 0 | 338988.422 | 4415442.505 | | | wc | | Y | |
| 276 | | 402779 | -88.896436 | 39.862829 | 8 16N | | | 03E | | DECATUR BOTTLING CO | | | | | | | | | | | | n | n | x | | Y | | |
| 277 | 121150093400 | 402781 | -88.883496 | 39.866526 | 5 16 N | | | 3 | E | Decatur Park Dist | | Mashburn Brothers | WATER | 67 | | 98 | sand and gravel | 92 | 98 | 30 | 338907.5173 | 4414640.669 | | | wc | | Y | |
| 278 | 121152185700 | 402785 | -88.882028 | 39.865652 | 5 16 N | | | 3 | E | Decatur Park District | 2 | Mashburn, Grover C. Jr. | WATER | 5 | | 101 | sand & gravel | 64 | 101 | 150 | 339031.0379 | 4414541.01 | | | wc | | Y | |
| 279 | | 405494 | -88.856543 | 39.896608 | 27 17N | | | 03E | | LONG CREEK TOWNSHIP | | SHADOW MANUFACTURING | | | | 104 | | | | | | n | n | x | -1 | Y | | |
| 280 | | 407634 | -88.854161 | 39.898416 | 27 17N | | | 03E | | LONG CREEK TOWNSHIP | | ALBRECHT WELL DRIG | | | | 94 | | | | | | n | n | x | -1 | Y | | |
| 281 | 121152113100 | 407635 | -88.856105 | 39.895971 | 27 17 N | | | 3 | E | Long Creek, Township of | 1 | Layne Western Co., Inc. | WATER | 66 | | 107 | sand and gravel | 59 | 105 | 305 | 341318.2889 | 4417859.99 | | | wc | | Y | |
| 282 | | 411204 | -88.864187 | 39.883522 | 33 17N | | | 03E | | ADM CORN SWEETENERS | | | | | | | | | | | | n | n | x | | Y | | |
| 283 | 121152203900 | 428754 | -88.882215 | 39.879351 | 32 17 N | | | 3 | E | Sebens, Gary | | Luttrell, Gerald Dean | WATER | 0 | | 55 | gray sand & gravel | 48 | 51 | 0 | 339047.0777 | 4416061.916 | | | wd | | Y | |
| 284 | 121152203200 | 428880 | -88.868686 | 39.901531 | 28 17 N | | | 3 | E | Leevy, Warren | 1 | Mashburn, Grover C. Jr. | WATER | 0 | | 108 | sand | 101 | 108 | 20 | 340255.5643 | 4418499.577 | | | wd | | Y | |
| 285 | 121152206100 | 428881 | -88.873395 | 39.905117 | 28 17 N | | | 3 | E | Garratt, Gerald | 2 | Wiesenhofer, Andrew | WATER | 0 | | 155 | gray sand | 105 | 106 | 0 | 339981.3421 | 4418906.056 | | | wd | | Y | |
| 286 | 121152208700 | 428882 | -88.873418 | 39.906947 | 28 17 N | | | 3 | E | Jones, Vernie | | Link, Harold F. | WATER | 0 | | 40 | gravel | 13 | 24 | 0 | 339863.6384 | 4419109.225 | | | wd | | Y | |
| 287 | 121152207900 | 428883 | -88.877995 | 39.899547 | 28 17 N | | | 3 | E | Smalley, Gary | 1 | Mashburn, Grover C. Jr. | WATER | 0 | | 118 | sand | 113 | 118 | 15 | 339455.1026 | 4418296.052 | | | wd | | Y | |
| 288 | 121150000600 | | -88.877962 | 39.902091 | 28 17 N | | | 3 | E | Rhodes, Wm. | 1 | Eureka Oil Corp | DA | 68 | | 2248 | | | | | | Y | o | | | Y | | |
| 289 | 121150033500 | | -88.876394 | 39.877753 | 4 16 N | | | 3 | E | Decatur Gun Club | | No Company | WATER | 67 | | 75 | | 0 | 0 | 0 | 339541.1522 | 4415874.068 | | | wc | | Y | |
| 290 | 121150033600 | | -88.882684 | 39.867231 | 5 16 N | | | 3 | E | Archer-Daniel-Midland Co. | | Lenz, Tony | WATER | 5 | | 108 | | 0 | 0 | 0 | 338978.6198 | 441471.459 | | | wc | | Y | |

| PERMIT MAP ID | API NUMBER | ISWPNUM | DD_N83_X | DD_N83_Y | SECTION | TWP | TDIR | RNG | RDIR | owner | well number | driller | status | elev | ELEV REF | depth total last | water from | depth open interval top | depth open interval bottom | cr pumping gpm | U16_X | U16_Y | abandoned | plugged | well type | date sealed | well use | inside_AoR |
|---------------|--------------|---------|------------|-----------|---------|-----|------|-----|------|-----------------------------|-------------|--------------------------|--------|------|----------|------------------|-----------------|-------------------------|----------------------------|----------------|-------------|-------------|-------------|---------|-----------|-------------|----------|------------|
| 291 | 121150036000 | | -88.888397 | 39.856152 | 8 | 16 | N | 3 | E | Burks, A. B. | | Woollen Brothers | WATER | 65 | 6 | GL | 66 | | 0 | 0 | 0 | 338463.9816 | 4413498.019 | | wd | | Y | |
| 292 | 121150036400 | | -88.891962 | 39.858022 | 8 | 16 | N | 3 | E | Hank, J. | | Lenz, Tony | WATER | 68 | 0 | 80 | | 0 | 0 | 0 | 0 | 338163.4009 | 4413712.036 | | wd | | Y | |
| 293 | 121150053900 | | -88.887617 | 39.908654 | 20 | 17 | N | 3 | E | Kury | 1 | Myers, Theodore F. | DAP | 68 | 8 | KB | 2226 | | | | | 338653.5941 | 4419311.614 | Y | 0 | | Y | |
| 294 | 121150054000 | | -88.882891 | 39.910499 | 20 | 17 | N | 3 | E | Stout, Bernia | 1 | Robinson, H. F., Inc. | DAOP | 68 | 9 | DF | 2239 | | | | | 339062.1672 | 4419520.53 | Y | 0 | | Y | |
| 295 | 121150054700 | | -88.878037 | 39.902947 | 28 | 17 | N | 3 | E | Clements, Belle | 1 | Davis, C. G. | DAO | 67 | 8 | DF | 5 | | | | | 339459.4499 | 4418673.525 | | 0 | | Y | |
| 296 | 121150054800 | | -88.880339 | 39.899509 | 29 | 17 | N | 3 | E | Boyd | 1 | Davis, C. G. | DA | 68 | 6 | DF | 2282 | | | | | 339254.6184 | 4418296.052 | Y | 0 | | Y | |
| 297 | 121150054900 | | -88.894578 | 39.901021 | 29 | 17 | N | 3 | E | Boyd, A. T. | 1 | Weiker Oil Co., Ltd. | OILP | 68 | 0 | GL | 2240 | | | | | 338040.8446 | 4418489.615 | Y | 0 | | Y | |
| 298 | 121150055000 | | -88.879867 | 39.905957 | 29 | 17 | N | 3 | E | McKee, John H., Sr. | 1 | Costello Leonard J | DA | 0 | 0 | 2251 | | | | | | 339310.0404 | 4419010.924 | Y | 0 | | Y | |
| 299 | 121150055100 | | -88.86663 | 39.881547 | 33 | 17 | N | 3 | E | Oakley Damsite T.H. | 1 | U S Engineering Dept | ENG | 64 | 3 | GL | 43 | | | | | 340413.1889 | 4416277.113 | | e | | Y | |
| 300 | 121150055200 | | -88.86517 | 39.882482 | 33 | 17 | N | 3 | E | Oakley Damsite T.H. | 2 | U S Engineering Dept | ENG | 62 | 1 | GL | 45 | | | | | 340511.9881 | 4416378.878 | | e | | Y | |
| 301 | 121150055300 | | -88.868558 | 39.881495 | 33 | 17 | N | 3 | E | Oakley Damsite T.H. | 3 | U S Engineering Dept | ENG | 65 | 2 | GL | 53 | | | | | 340219.9749 | 4416275.378 | | e | | Y | |
| 302 | 121150055400 | | -88.868558 | 39.881495 | 33 | 17 | N | 3 | E | Oakley Damsite T. | .4 | U S Engineering Dept | ENG | 64 | 0 | GL | 45 | | | | | 340219.9749 | 4416275.378 | | e | | Y | |
| 303 | 121150055500 | | -88.864031 | 39.885233 | 33 | 17 | N | 3 | E | Oakley Damsite T.H. | 5 | U S Engineering Dept | ENG | 61 | 8 | GL | 55 | | | | | 340615.761 | 4416882.202 | | e | | Y | |
| 304 | 121150055600 | | -88.861772 | 39.883465 | 33 | 17 | N | 3 | E | Oakley Damsite T.H. | 6 | U S Engineering Dept | ENG | 62 | 0 | GL | 55 | | | | | 340804.8389 | 4416481.927 | | e | | Y | |
| 305 | 121150055700 | | -88.859398 | 39.885321 | 34 | 17 | N | 3 | E | Oakley Damsite T. H. | 7 | U S Engineering Dept | ENG | 63 | 2 | GL | 40 | | | | | 341012.1347 | 4416883.712 | | e | | Y | |
| 306 | 121150055800 | | -88.861798 | 39.87983 | 33 | 17 | N | 3 | E | Reas Bridge Park | 1 | Pearcy Ed B | UNK | 0 | 0 | 35 | | | | | 340794.2058 | 4416078.494 | | wc | | Y | | |
| 307 | 121150061800 | | -88.882787 | 39.877494 | 5 | 16 | N | 3 | E | Rowe | | Burt, Luther R. | GAS | 67 | 5 | GL | 88 | | | | | 338993.817 | 4415856.823 | | 0 | | Y | |
| 308 | 121150073300 | | -88.86401 | 39.894324 | 28 | 17 | N | 3 | E | | CO-534 | U. S. Army Corps of Eng. | ENG | 60 | 8 | GL | 114 | | | | | 340638.6178 | 4417691.253 | | e | | Y | |
| 309 | 121150073400 | | -88.869792 | 39.893296 | 33 | 17 | N | 3 | E | | CO-514 | U S Army Corp Of Eng | ENG | 60 | 4 | GL | 123 | | | | | 340141.8718 | 4417587.481 | | e | | Y | |
| 310 | 121150073500 | | -88.86857 | 39.893314 | 33 | 17 | N | 3 | E | | CO-509 | U S Army Corp Of Eng | ENG | 65 | 2 | GL | 160 | | | | | 340223.1724 | 4416477.305 | | e | | Y | |
| 311 | 121150073900 | | -88.869992 | 39.910357 | 20 | 17 | N | 3 | E | Roos-Kuny | 1 | Atkins and Hale | DAP | 68 | 3 | KB | 2229 | | | | | 338454.8448 | 4419517.595 | Y | 0 | | Y | |
| 312 | 121150080700 | | -88.856381 | 39.896281 | 27 | 17 | N | 3 | E | Long Creek Water District T | 1 | Baker, E. C. & Sons | WTST | 0 | 0 | 115 | sand and gravel | 99 | 109 | 5 | 341124.4135 | 4417898.447 | Y | wc | | Y | | |
| 313 | 121150081000 | | -88.856022 | 39.896287 | 27 | 17 | N | 3 | E | Long Creek Water District T | 2 | Baker, E. C. & Sons | WTST | 0 | 0 | 101 | sand and gravel | 86 | 96 | 5 | 341155.1207 | 4417898.474 | Y | wc | | Y | | |
| 314 | 121150081100 | | -88.858556 | 39.896277 | 27 | 17 | N | 3 | E | Long Creek Pub Water Dist T | 3 | Baker, E. C. & Sons | WTST | 0 | 0 | 121 | sand and gravel | 100 | 121 | 150 | 341109.1004 | 4417898.321 | Y | wc | | Y | | |
| 315 | 121150082900 | | -88.860538 | 39.893489 | 33 | 17 | N | 3 | E | | CO-539 | U S Army Corp Of Eng | ENG | 61 | 2 | GL | 62 | | | | | 340933.5401 | 4417592.379 | | e | | Y | |

| PERMIT MAP ID | API NUMBER | ISWPNUM | DN 83_X | DN 83_Y | SECTION | TWP | TDIR | RNG | RDIR | owner | well number | driller | status | elev | ELEV REF | depth total last | water from | depth open interval top | depth open interval bottom | cr pumping gpm | U16_X | U16_Y | abandoned | plugged | well type | date sealed | well use | inside_Aor |
|---------------|--------------|---------|------------|-----------|---------|-----|------|-----|------|-----------------------------|-------------|----------------------------|--------|------|----------|------------------|------------|-------------------------|----------------------------|----------------|-------------|-------------|-------------|---------|-----------|-------------|----------|------------|
| 316 | 121150089500 | | -88.92566 | 39.876384 | 36 | 17 | N | 2 | E | SBI 48 bridge | 3 | IL Dept. of Transportation | ENG | 68 | 1 | GL | 41 | | 0 | 0 | 0 | 335329.4242 | 4416033.769 | | e | | Y | |
| 317 | 121150102000 | | -88.898806 | 39.900165 | 30 | 17 | N | 3 | E | Christian, Ray H. | 1 | Hanks, T. R. | WATER | 0 | | 113 | sand | 108 | 113 | 25 | 337677.3672 | 4418402.278 | | wd | | Y | | |
| 318 | 121152107800 | | -88.860538 | 39.893489 | 27 | 17 | N | 3 | E | Long Creek Township | D | Layne Western Co., Inc. | WTST | 0 | | 121 | | 0 | 0 | 0 | 340933.5401 | 4417592.379 | Y | wc | | Y | | |
| 319 | 121152115800 | | -88.85555 | 39.890806 | 34 | 17 | N | 3 | E | Oakley Dam | 618 | Engineers, Corp. of | ENG | 66 | 6 | GL | 145 | | 0 | 0 | 0 | 341353.8276 | 4417285.696 | | e | | Y | |
| 320 | 121152115900 | | -88.855536 | 39.892324 | 34 | 17 | N | 3 | E | Oakley Dam | 619 | Engineers, Corp. of | ENG | 66 | 0 | GL | 149 | | 0 | 0 | 0 | 341358.5255 | 4417454.167 | | e | | Y | |
| 321 | 121152116000 | | -88.867224 | 39.884038 | 33 | 17 | N | 3 | E | Oakley Dam | T.H.C. | Engineers, Corp. of | ENG | 61 | 4 | GL | 112 | | 0 | 0 | 0 | 340339.9528 | 4416555.261 | | e | | Y | |
| 322 | 121152133800 | | -88.894475 | 39.868894 | 5 | 16 | N | 3 | E | A.D.M. | 1 | Archer Daniels Midland | DAOP | 68 | 2 | KB | 2315 | | | | 337974.0121 | 4414923.366 | Y | Y | 0 | Y | | |
| 323 | 121152138100 | | -88.880462 | 39.90625 | 29 | 17 | N | 3 | E | French | 1 | Davis, C. G. | DAP | 69 | 3 | KB | 2294 | | | | 339259.8619 | 4419044.518 | Y | Y | 0 | Y | | |
| 324 | 121152149400 | | -88.916509 | 39.900583 | 30 | 17 | N | 3 | E | Schwarze, R. D. | 1 | Triple G Oil Company Ltd. | DAP | 68 | 4 | KB | 2187 | | | | 336164.8916 | 4418481.011 | Y | Y | 0 | Y | | |
| 325 | 121152152400 | | -88.878011 | 39.901374 | 28 | 17 | N | 3 | E | Cundiff | 1 | Davis, C. G. | DAP | 68 | 9 | KB | 2285 | | | | 339468.0001 | 4418498.876 | Y | Y | 0 | Y | | |
| 326 | 121152165000 | | -88.921076 | 39.89304 | 25 | 17 | N | 2 | E | Harrison-Oliver Community | 1 | Triple G Oil Company Ltd. | DAP | 65 | 6 | GL | 2500 | | | | 335756.437 | 4417652.133 | Y | Y | 0 | Y | | |
| 327 | 121152185200 | | -88.921199 | 39.898497 | 25 | 17 | N | 2 | E | Bathauer Community | 1 | Triple G Oil Company Ltd. | OILP | 67 | 6 | KB | 2223 | | | | 335758.9523 | 4418258.083 | Y | Y | 0 | Y | | |
| 328 | 121152225100 | | -88.888397 | 39.856152 | 8 | 16 | N | 3 | E | Durbin | 1 | | WATER | 0 | | 0 | | 0 | 0 | 0 | 338463.9816 | 4413498.019 | | wd | | Y | | |
| 329 | 121152238700 | | -88.856384 | 39.895177 | 27 | 17 | N | 3 | E | Oakley Damsite | 612 | Baker, E. C. & Sons | ENG | 62 | 9 | GL | 93 | | | | 341121.6068 | 4417775.91 | | e | | Y | | |
| 330 | 121152241400 | | -88.893872 | 39.866038 | 5 | 16 | N | 3 | E | Archer Daniels Midland Co | 2 | Layne-Western | WTST | 0 | | 90 | | 0 | 0 | 0 | 338035.9749 | 4414604.898 | | wc | | Y | | |
| 331 | 121152241500 | | -88.889755 | 39.868025 | 5 | 16 | N | 3 | E | Grove Rd @ Sand Cr. Boring | 2 | Baker, E. C. & Sons | ENG | 0 | | 36 | | 0 | 0 | 0 | 338375.6789 | 4414818.359 | | e | | Y | | |
| 332 | 121152241600 | | -88.889755 | 39.868025 | 5 | 16 | N | 3 | E | Grove Rd. @ Sand Cr. Boring | 3 | Baker, E. C. Baker & Sons | ENG | 0 | | 0 | | 0 | 0 | 0 | 338375.6789 | 4414818.359 | | e | | Y | | |
| 333 | 121152241900 | | -88.899123 | 39.862318 | 7 | 16 | N | 3 | E | West Plant Addition | 2 | Baker, E. C. & Sons | ENG | 0 | | 0 | | 0 | 0 | 0 | 337560.9493 | 4414201.879 | | e | | Y | | |
| 334 | 121152243900 | | -88.917219 | 39.884926 | 31 | 17 | N | 3 | E | Caterpillar Tractor T | 3 | Burt, Luther | WTST | 0 | | 0 | | 0 | 0 | 0 | 336066.8813 | 4416744.398 | Y | wc | | Y | | |
| 335 | 121152244000 | | -88.909451 | 39.885072 | 31 | 17 | N | 3 | E | Caterpillar Tractor TH | 4 | Burt, Luther | WTST | 0 | | 117 | | 0 | 0 | 0 | 336731.4801 | 4416746.374 | Y | wc | | Y | | |
| 336 | 121152246400 | | -88.866765 | 39.896581 | 27 | 17 | N | 3 | E | Long Creek PWS | TH-194 | Layne-Western Co. | WTST | 65 | 0 | GL | 105 | | 0 | 0 | 341263.2687 | 4417928.872 | Y | wc | | Y | | |
| 337 | 121152260900 | | -88.8629 | 39.884349 | 33 | 17 | N | 3 | E | Lake Decatur Sediments | | IL State Water Survey | STRAT | 0 | | 45 | | | | | 340710.427 | 4416582.061 | | s | | Y | | |
| 338 | 121152261000 | | -88.8629 | 39.884349 | 33 | 17 | N | 3 | E | Lake Decatur Sediments | | IL State Water Survey | STRAT | 0 | | 2 | | | | | 340710.427 | 4416582.061 | | s | | Y | | |
| 339 | 121152262700 | | -88.869254 | 39.89715 | 27 | 17 | N | 3 | E | Long Creek, Town of | 2 | Albrecht, S. Dean | WATER | 0 | | 0 | | | | | 341051.7632 | 4417996.458 | | wc | | Y | | |
| 340 | 121152301600 | | -88.887658 | 39.914079 | 20 | 17 | N | 3 | E | Oasis Truck Stop | | | WATER | 0 | | 0 | | 0 | 0 | 0 | 338663.0903 | 4419826.513 | | wc | | Y | | |
| 341 | 121152301700 | | -88.854514 | 39.896312 | 27 | 17 | N | 3 | E | Long Creek Township PWS | 2 | | WATER | 0 | | 86 | | 0 | 0 | 0 | 341455.1009 | 4417895.014 | | wc | | Y | | |
| 342 | 121152301800 | | -88.886873 | 39.899707 | 28 | 17 | N | 3 | E | Whitmore Park | | | WATER | 0 | | 0 | | 0 | 0 | 0 | 340252.4385 | 4418297.092 | | wd | | Y | | |

| PERMIT MAP ID | API NUMBER | ISWSPNUM | DD_N83_X | DD_N83_Y | SECTION | TWP | TDIR | RNG | RDIR | owner | well number | driller | status | elev | ELEV REF | depth total last | water from | depth open interval top | depth open interval bottom | cr pumping gpm | U16_X | U16_Y | abandoned | plugged | well type | date sealed | well use | inside_Aor |
|---------------|----------------|----------|------------|-----------|---------|-----|------|-----|------|----------------------------|-------------|----------------------------------|---------|------|----------|------------------|---------------|-------------------------|----------------------------|----------------|------------|-------------|-----------|---------|-----------|-------------|----------|------------|
| 343 | 121152443600 | | -88.82866 | 39.878384 | 36 | 17 | N | 2 | E | Cities Service | 1 | Lenz, Neil Drilling | WTS1 | 0 | 0 | 0 | | 0 | 0 | 0 | 33529.4242 | 4416033.769 | Y | | wc | | Y | |
| 344 | 1711521338000C | | -88.894475 | 39.868894 | 5 | 16 | N | 3 | E | ARCHER DANIALS MIDLAND CO. | | ARCHER DANIALS MIDLAND CO. | COALSEC | 67 | 9 | 906 | | | | | 337974 | 4414923 | | | c | | Y | |
| 345 | 121152345600 | 450826 | -88.868283 | 39.904883 | 28 | 17 | N | 3 | E | Rhodes, John | 2 | Mashburn, Robert | WATER | 66 | | 103 | sand | 98 | 103 | 12 | | | | | | Y | | |
| 346 | 121152342800 | 447202 | -88.866944 | 39.863889 | 4 | 16 | N | 3 | E | Big Brothers Big Sisters | | S & J Well Drilling | DRYP | 2 | | 90 | dry | | | | | | | | | Y | | |
| 347 | 121152343000 | 447188 | -88.866223 | 39.894279 | 28 | 17 | N | 3 | E | McCarty, Ronald Jr. | | S & J Well Drilling | DRY | 74 | | 107 | | | | | | | | | | Y | | |
| 348 | 121152342000 | 445303 | -88.868333 | 39.893889 | 28 | 17 | N | 3 | E | McCarty, Ronald W. | 1 | Skinner, Todd | WATER | 9 | | 45 | silty sand | 34 | 45 | | | | | | | Y | | |
| 349 | 121152342100 | 445259 | -88.873129 | 39.885032 | 33 | 17 | N | 3 | E | Moore, Timothy | | S & J Well Drilling | WATER | | | 95 | sand | 81 | 95 | 15 | | | | | | Y | | |
| 350 | 121152341900 | 445201 | -88.868539 | 39.860951 | 9 | 16 | N | 3 | E | Steve's Trucking Inc | | Mashburn, Robert | DRY | | | 135 | dry | | | | | | | | | Y | | |
| 351 | 121152340700 | 442072 | -88.899121 | 39.862319 | 7 | 16 | N | 3 | E | ADM West Refinery | | S & J Well Drilling | WATER | | | 106 | sand | 86 | 106 | 130 | | | | | | Y | | |
| 352 | 121152340800 | 442066 | -88.897085 | 39.90837 | 20 | 17 | N | 3 | E | Pressley, Jerry | | S & J Well Drilling | WATER | 64 | | 113 | sand | 109 | 113 | 10 | | | | | | Y | | |
| 353 | 121152338100 | 437333 | -88.881944 | 39.863889 | 5 | 16 | N | 3 | E | ADM | TW1 | S & J Well Drilling | WATER | 7 | | 99 | sand | 55 | 99 | | | | | | | Y | | |
| 354 | 121152337200 | 433210 | -88.878611 | 39.897222 | 33 | 17 | N | 3 | E | Crain, Mark D. | | S & J Well Drilling | WATER | 66 | | 105 | sand | 95 | 105 | 20 | | | | | | Y | | |
| 355 | 121152335700 | 430488 | -88.874533 | 39.910933 | 21 | 17 | N | 3 | E | Marlowe, Harold | | Mashburn, Robert | WATER | | | 112 | sand & gravel | 106 | 112 | 15 | | | | | | Y | | |
| 356 | 121150054700 | | -88.878037 | 39.902947 | 28 | 17 | N | 3 | E | Clements, Belle | 1 | Davis, C. G. | DAO | 67 | 8 | DF | | | | | | | | | | Y | | |
| 357 | 121152337800 | | -88.893100 | 39.877291 | 5 | 16 | N | 3 | E | Archer Daniels Midland | MMV-01B | Illinois State Geological Survey | CONF | 67 | 5 | T | | | | | | | | | | Y | | |
| 358 | 121152339000 | | -88.906438 | 39.88261 | 31 | 17 | N | 3 | E | ADM | MMV-02S | Illinois State Geological Survey | CONF | | | 28 | | | | | | | | | | Y | | |
| 359 | 121152339100 | | -88.902668 | 39.874274 | 6 | 16 | N | 3 | E | Decatur, City of | 1 well | IL State Geological Survey | WATER | | | | | | | | | | | | | Y | | |
| 360 | 121152339200 | | -88.897096 | 39.883867 | 32 | 17 | N | 3 | E | ADM | MMV-03S | Illinois State Geological Survey | CONF | | | 24 | | | | | | | | | | Y | | |
| 361 | 121152339300 | | -88.897136 | 39.881135 | 32 | 17 | N | 3 | E | ADM | MMV-04S | Illinois State Geological Survey | CONF | | | 28 | | | | | | | | | | Y | | |
| 362 | 121152339400 | | -88.89712 | 39.881118 | 32 | 17 | N | 3 | E | ADM | MMV-04UG | Illinois State Geological Survey | CONF | | | 67 | | | | | | | | | | Y | | |
| 363 | 121152339500 | | -88.897099 | 39.88109 | 32 | 17 | N | 3 | E | ADM | MMV-04P | Illinois State Geological Survey | CONF | | | 99 | | | | | | | | | | Y | | |
| 364 | 121152339600 | | -88.897184 | 39.881084 | 32 | 17 | N | 3 | E | ADM | MMV-04B | Illinois State Geological Survey | MONIT | 86 | 1 | 504 | | | | | | | | | | Y | | |
| 365 | 121152339700 | | -88.897721 | 39.876167 | 5 | 16 | N | 3 | E | ADM | MMV-07UG | Illinois State Geological Survey | CONF | | | 75 | | | | | | | | | | Y | | |
| 366 | 121152339800 | | -88.889172 | 39.879638 | 5 | 16 | N | 3 | E | ADM | MMV-05S | Illinois State Geological Survey | CONF | | | 22 | | | | | | | | | | Y | | |
| 367 | 121152339900 | | -88.889442 | 39.875701 | 5 | 16 | N | 3 | E | ADM | MMV-08UG | Illinois State Geological Survey | CONF | | | 60 | | | | | | | | | | Y | | |
| 368 | 121152340000 | | -88.889384 | 39.87569 | 5 | 16 | N | 3 | E | ADM | MMV-08S | Illinois State Geological Survey | CONF | | | 25 | | | | | | | | | | Y | | |

| PERMIT MAP ID | API NUMBER | ISWSPNUM | DD_N83_X | DD_N83_Y | SECTION | TWP | TDIR | RNG | RDIR | owner | well number | driller | status | elev | ELEV REF | depth total last known | water from | depth open interval top | depth open interval bottom | cr pumping gpm | U16_X | U16_Y | abandoned | plugged | well type | date sealed | well use | inside_AoR |
|---------------|--------------|----------|----------|----------|---------|-----|------|-----|------|---------------------------|-------------|---------------|--------|------|----------|------------------------|------------|-------------------------|----------------------------|----------------|-------|-------|-----------|---------|-----------|-------------|----------|------------|
| 393 | 121152195800 | 89514 | | | 33 | 17N | 03E | | | LARRY SMALLLEY | | G C MASHBURN | | | | 90 | | | | | | | n | n | wd | O | Y | |
| 394 | | 89771 | | | 5 | 16N | 03E | | | ARCHER DANIELS MIDLAND CO | | TONY LENTZ | | | | 92 | | | | | | | n | n | wc | IC | Y | |
| 395 | | 89772 | | | 5 | 16N | 03E | | | ARCHER DANIELS MIDLAND CO | | LENTZ | | | | 116 | | | | | | | n | n | wc | IC | Y | |
| 396 | | 89778 | | | 5 | 16N | 03E | | | BAUER AUTO WRECKING | | LENTZ | | | | 93 | | | | | | | n | n | wc | IC | Y | |
| 397 | | 89861 | | | 5 | 16N | 03E | | | FARIES PARK | | | | | | 20 | | | | | | | n | n | x | PK | Y | |
| 398 | | 89862 | | | 5 | 16N | 03E | | | FARIES PARK | | | | | | 25 | | | | | | | n | n | x | PK | Y | |
| 399 | | 89863 | | | 5 | 16N | 03E | | | FARIES PARK | | | | | | 42 | | | | | | | n | n | x | PK | Y | |
| 400 | | 89864 | | | 5 | 16N | 03E | | | FARIES PARK | | | | | | 35 | | | | | | | n | n | x | PK | Y | |
| 401 | | 89865 | | | 5 | 16N | 03E | | | FARIES PARK | | | | | | 56 | | | | | | | n | n | x | PK | Y | |
| 402 | | 89866 | | | 5 | 16N | 03E | | | FARIES PARK | | | | | | 25 | | | | | | | n | n | x | PK | Y | |
| 403 | | 89867 | | | 5 | 16N | 03E | | | FARIES PARK | | | | | | 35 | | | | | | | n | n | x | PK | Y | |
| 404 | | 89868 | | | 5 | 16N | 03E | | | FARIES PARK | | | | | | 12 | | | | | | | n | n | x | PK | Y | |
| 405 | | 89870 | | | 4 | 16N | 03E | | | DECATUR PARK DIST | | LENTZ | | | | 50 | | | | | | | n | n | x | PK | Y | |
| 406 | | 89871 | | | 5 | 16N | 03E | | | DECATUR PARK DIST | | MASHBURN BROS | | | | 98 | | | | | | | n | n | x | PK | Y | |
| 407 | | 89902 | | | 1 | 16N | 02E | | | HEINKLE PACKING CO | | LENTZ | | | | 88 | | | | | | | n | n | wc | IC | Y | |
| 408 | | 89966 | | | 1 | 16N | 02E | | | MCBRIDES TRUCK REPAIR | | T R HANKS | | | | 67 | | | | | | | n | n | wc | IC | Y | |
| 409 | | 200896 | | | 5 | 16N | 03E | | | ARCHER DANIELS MIDLAND CO | | | | | | 123 | | | | | | | n | n | wc | IC | Y | |
| 410 | | 200899 | | | 5 | 16N | 03E | | | ARCHER DANIELS MIDLAND CO | | | | | | 116 | | | | | | | n | n | wc | IC | Y | |
| 411 | | 200901 | | | 5 | 16N | 03E | | | ARCHER DANIELS MIDLAND CO | | LENTZ | | | | 109 | | | | | | | n | n | wc | IC | Y | |
| 412 | | 200904 | | | 5 | 16N | 03E | | | ARCHER DANIELS MIDLAND CO | | LENTZ | | | | 116 | | | | | | | n | n | wc | IC | Y | |
| 413 | | 201025 | | | 5 | 16N | 03E | | | DECATUR PARK DIST | | | | | | 20 | | | | | | | n | n | x | PK | Y | |
| 414 | | 201026 | | | 5 | 16N | 03E | | | DECATUR PARK DIST | | | | | | 42 | | | | | | | n | n | x | PK | Y | |
| 415 | | 201028 | | | 5 | 16N | 03E | | | DECATUR PARK DIST | | | | | | 56 | | | | | | | n | n | x | PK | Y | |
| 416 | | 201030 | | | 5 | 16N | 03E | | | DECATUR PARK DIST | | | | | | 25 | | | | | | | n | n | x | PK | Y | |
| 417 | | 201031 | | | 5 | 16N | 03E | | | DECATUR PARK DIST | | | | | | 35 | | | | | | | n | n | x | PK | Y | |
| 418 | | 201032 | | | 4 | 16N | 03E | | | DECATUR PARK DIST | | | | | | 102 | | | | | | | n | n | x | PK | Y | |
| 419 | | 201034 | | | 4 | 16N | 03E | | | DECATUR PARK DIST | | LENTZ | | | | 50 | | | | | | | n | n | x | PK | Y | |

APPENDIX E

APPENDIX E – Materials Analysis Plan

| | | | |
|---|--|-------------------------------|---------------------------------|
|  | ADM Decatur CO₂ Sequestration Plant | VERSION: 1.0 | DOCUMENT: 180.SOP.CO2 |
| | Material Analysis Plan Carbon Dioxide for Underground Injection | ISSUED: 3/13/08 | LINKAGE: None |
| | | PAGE: Page 26 of 41 | AUTHOR: MC |

1.0 Purpose

The purpose of this document is to provide a plan for sampling and analysis of carbon dioxide destined for sequestration at the ADM Decatur location.

2.0 Parameters and Rationale

The CO₂ will typically be analyzed for the following constituents (the list of parameters to be analyzed may be altered as experience provides a clearer picture of the constituents of concern):

- CO₂ Identification (% v/v)
- Water Vapor, Moisture (ppm v/v)
- Oxygen (ppm v/v)

Volatiles Sulfur Compounds (VSC, ppm v/v)

- Hydrogen Sulfide (H₂S)
- Sulfur Dioxide (SO₂)

Volatiles Oxygenates (VOX, ppm v/v)

- Acetaldehyde
- Ethanol

| | | | |
|---|--|-------------------------------|---------------------------------|
|  | ADM Decatur CO₂ Sequestration Plant | VERSION: 1.0 | DOCUMENT: 180.SOP.CO2 |
| | Material Analysis Plan Carbon Dioxide for Underground Injection | ISSUED: 3/13/08 | LINKAGE: None |
| | | PAGE: Page 27 of 41 | AUTHOR: MC |

3.0 Test Methods

Samples will be analyzed by a third party laboratory using standardized procedures for gas chromatography, mass spectrometry, detector tubes, and photo ionization.

4.0 Sampling Methods

Grab samples will be collected in a tedlar bag from a sample port located downstream of the Primary Fermentation scrubber and the dehydration and compression station, but prior to the injection wellhead.

5.0 Frequency of Analysis

Samples will be collected and analyzed once every calendar quarter.

| PERMIT MAP ID | API NUMBER | ISWSPNUM | DD_N83_X | DD_N83_Y | SECTION | TWP | TDIR | RNG | RDIR | owner | well number | driller | status | elev | ELEV REF | depth total last known | water from | depth open interval top | depth open interval bottom | cr pumping gpm | U16_X | U16_Y | abandoned | plugged | well type | date sealed | well use | inside_AoR |
|---------------|--------------|----------|----------|----------|---------|-----|------|-----|------|----------------------|-------------|----------------------|--------|------|----------|------------------------|------------|-------------------------|----------------------------|----------------|-------|-------|-----------|---------|-----------|-------------|----------|------------|
| | | | | | | | | | | FARIES PARK | | | | | | | | | | | | | | | | | | |
| 420 | | 201120 | | | 1 | 16N | 02E | | | HEINKLE MEAT MARKET | | LENTZ | | | | 67 | | | | | | | n | n | wc | | IC | Y |
| 421 | | 201122 | | | 1 | 16N | 02E | | | HEINKLE MEAT MARKET | | LENTZ | | | | 29 | | | | | | | n | n | wc | | IC | Y |
| 422 | | 201123 | | | 1 | 16N | 02E | | | HEINKLE MEAT MARKET | | LENTZ | | | | 32 | | | | | | | n | n | wc | | IC | Y |
| 423 | | 201124 | | | 1 | 16N | 02E | | | HEINKLE MEAT MARKET | | LENTZ | | | | 33 | | | | | | | n | n | wc | | IC | Y |
| 424 | | 201126 | | | 1 | 16N | 02E | | | HEINKLE MEAT MARKET | | LENTZ | | | | 88 | | | | | | | n | n | wc | | IC | Y |
| 425 | | 201128 | | | 1 | 16N | 02E | | | HEINKLE MEAT MARKET | | LENTZ | | | | 42 | | | | | | | n | n | wc | | IC | Y |
| 426 | | 201134 | | | 33 | 17N | 03E | | | HIGH COOK CAN CO | | MASHBURN | | | | 77 | | | | | | | n | n | wc | | IC | Y |
| 427 | | 375851 | | | 7 | 16N | 03E | | | ADM - WEST PLANT | | ROBERT MASHBURN | | | | 97 | | | | | | | y | y | wc 5 | 11/21/200 | IC | Y |
| 428 | 121152207500 | 402774 | | | 5 | 16N | 03E | | | ADM CORN SWEETENERS | | GROSCH IRRIGATION CO | | 67 | 3 | 103 | | | | | | | y | y | x | 2005 | | Y |
| 429 | | 428841 | | | 28 | 17N | 03E | | | KENNETH DAVIS #1 | | TODD SKINNER | | | | 81.5 | SAND | 63.00 | 68.00 | 40.00 | | | n | n | wd | | D | O |
| 430 | | 428878 | | | 28 | 17N | 03E | | | KEITH & DANA CHAPMAN | | UNKNOWN | | | | 103 | | | | | | | n | n | wd | | D | O |
| 431 | | 428879 | | | 28 | 17N | 03E | | | FRED STOLLEY | | UNKNOWN | | | | 60 | | | | | | | n | n | wd | | D | O |
| 432 | | 428913 | | | 28 | 17N | 03E | | | TERRY WOLPERT | | SHANE BALDING | | 7.8 | | 115 | SAND | 108.00 | 115.00 | 18.00 | | | n | n | wd | | D | O |

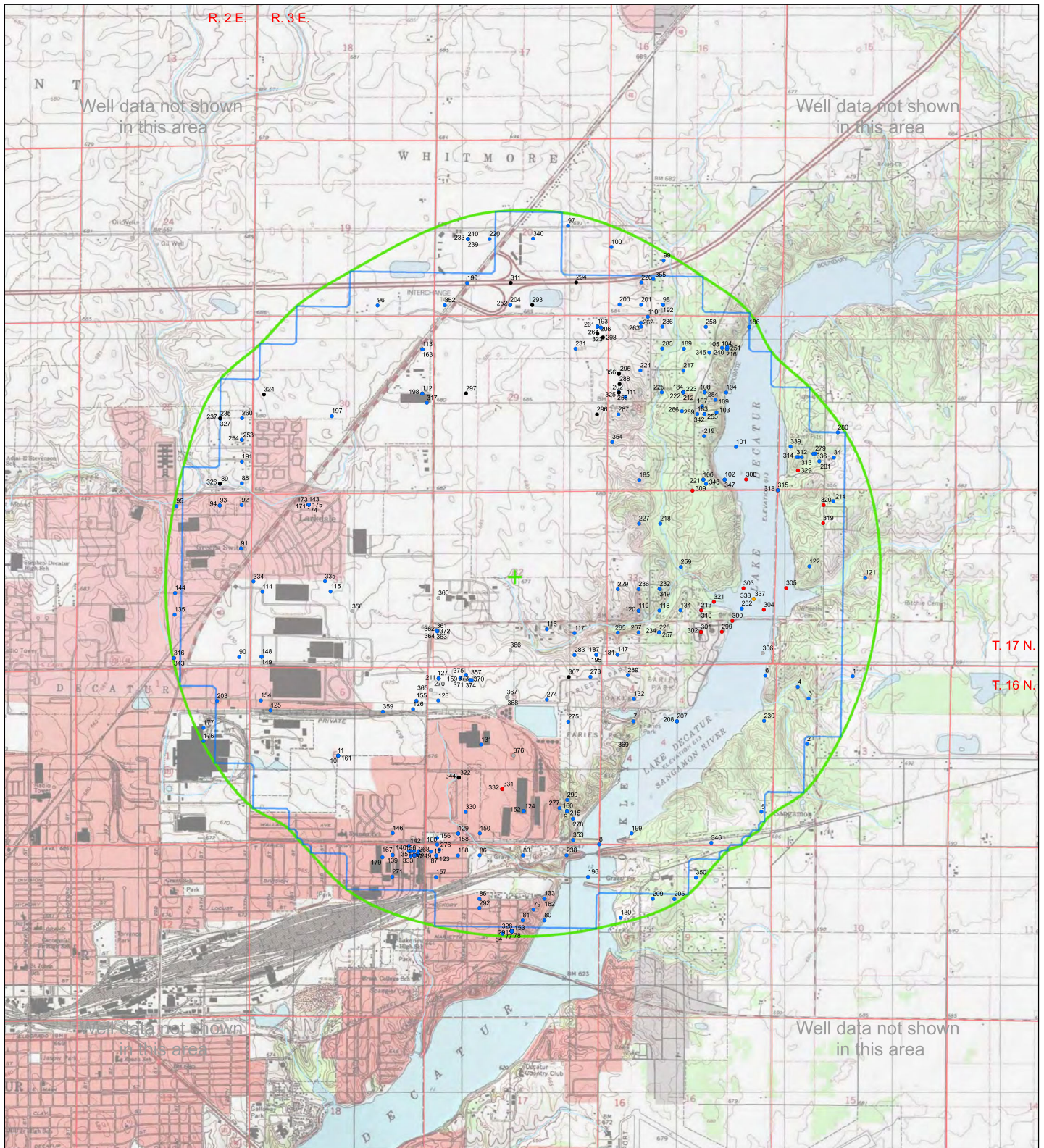

R. 2 E. R. 3 E.

Well data not shown in this area

Well data not shown in this area

T. 17 N.

T. 16 N.

Well data not shown in this area

Well data not shown in this area

- Water Well
 - Oil Well
 - Stratigraphic Test
 - Engineering Boring
 - Other / Unknown
- Area of Review
 - MESPOP Predicted by Computer Simulations
 - + Proposed IL-ICCS Well Location

Base: United States Geological Survey (USGS) 7.5-Minute Topographic Quadrangle map imagery and intermediate-scale DLG streams data, rescaled to 1:24,000. Topographic contour interval is 5 feet. Tiled topographic map imagery is sourced from scanned paper maps, and is provided by Esri's USGS Topographic Map Service (available at: http://gto.arcgisonline.com/maps/USA_Topo_Maps).

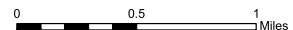

Original Printed Scale 1:24,000
One inch = 2,000 feet

Wells and borings within the Area of Review surrounding the proposed IL-ICCS injection well at the ADM Site, Decatur, IL. The green outline shows the Area of Review, which was used to select well location coordinates from ISGS and ISWS databases. Note that wells outside this area are not shown on this map. The well Map ID number shown for the purpose of this map can be cross-referenced to ISGS API Number and/or ISWS P-Number well identifiers in the accompanying data tables. Some wells may have multiple Map IDs assigned due to repeated drilling, testing, or sampling as identified in the source data tables.

APPENDIX E

APPENDIX E – Materials Analysis Plan

| | | | |
|---|--|-------------------------------|---------------------------------|
|  | ADM Decatur CO₂ Sequestration Plant | VERSION: 1.0 | DOCUMENT: 180.SOP.CO2 |
| | Material Analysis Plan Carbon Dioxide for Underground Injection | ISSUED: 3/13/08 | LINKAGE: None |
| | | PAGE: Page 26 of 41 | AUTHOR: MC |

1.0 Purpose

The purpose of this document is to provide a plan for sampling and analysis of carbon dioxide destined for sequestration at the ADM Decatur location.

2.0 Parameters and Rationale

The CO₂ will typically be analyzed for the following constituents (the list of parameters to be analyzed may be altered as experience provides a clearer picture of the constituents of concern):

- CO₂ Identification (% v/v)
- Water Vapor, Moisture (ppm v/v)
- Oxygen (ppm v/v)

Volatile Sulfur Compounds (VSC, ppm v/v)

- Hydrogen Sulfide (H₂S)
- Sulfur Dioxide (SO₂)

Volatile Oxygenates (VOX, ppm v/v)

- Acetaldehyde
- Ethanol

| | | | |
|---|--|-------------------------------|---------------------------------|
|  | ADM Decatur CO₂ Sequestration Plant | VERSION: 1.0 | DOCUMENT: 180.SOP.CO2 |
| | Material Analysis Plan Carbon Dioxide for Underground Injection | ISSUED: 3/13/08 | LINKAGE: None |
| | | PAGE: Page 27 of 41 | AUTHOR: MC |

3.0 Test Methods

Samples will be analyzed by a third party laboratory using standardized procedures for gas chromatography, mass spectrometry, detector tubes, and photo ionization.

4.0 Sampling Methods

Grab samples will be collected in a tedlar bag from a sample port located downstream of the Primary Fermentation scrubber and the dehydration and compression station, but prior to the injection wellhead.

5.0 Frequency of Analysis

Samples will be collected and analyzed once every calendar quarter.

APPENDIX F

APPENDIX F - Groundwater Monitoring Plan

**Groundwater Monitoring Plan for the Lowermost USDW
Illinois Industrial Carbon Capture & Sequestration (IL-ICCS) Project
Decatur, Illinois**

F.1. Purpose, Number of Wells, and Well Placement

The purpose of this proposed groundwater monitoring plan is to evaluate the variability of groundwater quality in the lowermost underground source of drinking water (USDW) during the project to determine if any significant impacts are occurring as a direct result of CO₂ injection at the IL-ICCS site. Four regulatory compliance monitoring wells in the Pennsylvanian bedrock are proposed. Figure F-1 shows areas within which wells will be placed. Two wells will be located within about 200 feet of the injection well. Two other monitoring wells will be located within approximately 400 and 2,000 feet from the injection well. Two monitoring wells will be located within 200 feet of the injection well because it is an area of greater risk for leakage. The exact location of wells will depend on the final location of the injection well and related infrastructure. Placement of wells within the 400 and 2000 foot zones will be considered in the context of effective determination of groundwater flow direction in the lowermost USDW and anticipated movement of the CO₂ plume in the Mt. Simon Formation. Because of its buoyancy, the injected CO₂ is expected to move upward in the injection zone and move updip. Regional maps of the Precambrian and the Mt. Simon (reference Figures 2-5 through 2-7 in Section 2 of this application) indicate that the updip direction of the Cambrian rocks is northwest.





F.2. Type of Wells

All groundwater monitoring wells will be installed and eventually abandoned according to Illinois Department of Public Health regulations. During drilling, representative cores will be collected at selected monitoring well locations and archived at the Illinois State Geological Survey. Field descriptions of the cores will be taken and the desired monitoring interval identified. Monitoring wells are planned to be constructed of 2-inch PVC materials or similarly suitable materials with threaded connections. Slotted well screen (e.g., 0.010 inch slot or similar as appropriately sized for formation and sand pack conditions) will be used. The screened interval will have a sand pack of appropriate thickness based on the monitoring interval identified from core samples. Bentonite will be used as the annular fill above the sand pack to near land surface. Concrete and a well protector will be placed at the surface. The locations and elevations of the monitoring wells will be determined by standard land surveying methods based on at least one local benchmark. As soon as practical after well construction and prior to implementing the sampling schedule, all wells will be developed with an inertial-lift pump, electric centrifugal submersible pump, positive air displacement pump, or similar equipment.

Figure F-1. IL-ICCS Injection Site Showing Groundwater Compliance Well Areas.
Two wells will be within 200 feet of the injection site, one within 400 feet, and one within 2,000 feet.



Base: November 2010 Aerial Imagery,
Illinois Department of Transportation

-  Proposed Injection Well
-  200 feet
-  400 feet
-  2,000 feet

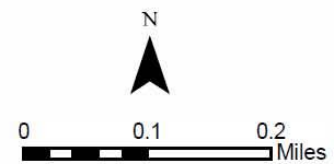

Original Printed Scale 1:8,000

IL-ICCS Site, Decatur, IL, showing proposed injection well and distance radii, in feet, from proposed well.

To ensure sample integrity and reduce the introduction of atmospheric CO₂ into the groundwater monitoring wells during sampling, dedicated pumps will be installed. The pumps, tubing, and any other downhole accessories will be rinsed with deionized water and placed in plastic bags for travel to the field site. During pump deployment and at other times, care will be taken to ensure that equipment to be used inside the monitoring wells remains clean and does not come in contact with potentially contaminating materials.

F.3. Initiation, Frequency and Duration of Monitoring

Shallow groundwater monitoring wells will be installed after the proposed USDW monitoring plan has been approved and could be installed as early as the fall of 2011. Pre-injection sampling will be initiated after sufficient well development has occurred to remove as much visible turbidity from the produced water as is practical. Background monitoring will begin as soon as practical and will continue quarterly before injection operations begins and water quality data suggests effects of well drilling and installation have subsided. Quarterly monitoring will continue thereafter for the duration of the permit and through year one of the post-injection phase. During the remainder of the post-injection site monitoring phase, sampling will be on a yearly basis.

F.4. Sampling Parameters, Sampling Methods, and Analytical Methods

For regulatory compliance purposes, we propose to analyze groundwater samples for the following:

Field Parameters:

- pH
- Specific Conductance
- Temperature
- Dissolved Oxygen

Indicator Parameters:

- Alkalinity
- Bromide
- Calcium
- Chloride
- Sodium
- Total CO₂

All indicator parameters of interest are inorganic and have been selected based on known chemical reactions of CO₂ in aqueous media. These parameters are expected to be key indicators in determining whether injected CO₂ has or has not impacted groundwater quality either 1) directly by introduction of CO₂ into shallow groundwater or 2) indirectly by CO₂-induced

migration of groundwater with differing chemical compositions (e.g., brine) into shallow groundwater.

Sample Containers

All sample bottles will be new. Sample bottles and bags for analytes will be used as received from the vendor or contract analytical laboratory or cleaned prior to use as appropriate for the analyte of interest.

Well Purging and Sampling

Static water levels in each well will be determined using an electronic water level indicator before any purging or sampling activities. Dedicated pumps (e.g., bladder pumps) will be installed in each monitoring well to minimize potential cross contamination between wells.

Groundwater pH, temperature, specific conductance, and dissolved oxygen will be monitored in the field using portable probes and a flow-through cell consistent with standard methods (e.g., APHA, 2005) given sufficient flow rates and volumes. Field chemistry probes will be calibrated at the beginning of each sampling day according to equipment manufacturer procedures using standard reference solutions. When a flow-through cell is used, field parameters will be continuously monitored and will be considered stable when three successive measurements made three minutes apart meet the criteria listed in Table F-1. It is anticipated that purging will primarily be conducted based on stabilization of the field parameters using a low-flow method. However, conditions (e.g., low well productivity) may require the use of other methods consistent with ASTM D6452-99 (2005) or Puls and Barcelona (1996). If a flow through cell is not used, field parameters will be measured in grab samples.

Table F-1. Stabilization criteria of water quality parameters during groundwater monitoring well purging

| FIELD PARAMETER | STABILIZATION CRITERIA |
|------------------------|---|
| pH | + / - 0.2 units |
| Temperature | + / - 1° C |
| Specific Conductance | + / - 3% of reading in µS/cm |
| Dissolved Oxygen | + / - 10% of reading or 0.3 mg/L whichever is greater |

Samples will be filtered through 0.45 µm flow-through filters as appropriate and consistent with ASTM D6564-00. Prior to sample collection, filters will be purged with a minimum of 100 milliliters of well water (or more if required by the filter manufacturer). For alkalinity and total CO₂ samples, efforts will be made to minimize exposure to the atmosphere during filtration, collection in sample containers, and analysis. Sample preservation techniques (Table F-2) will be consistent with those described in US EPA (1974), American Public Health Association (APHA, 2005), Wood (1976), and ASTM Method D6517-00 (2005). After collection, samples will be placed in ice chests in the field and maintained thereafter at approximately 4° C until analysis.

Table F-2. Sample preservation and containers

| ANALYTE | PRESERVATION ¹ | HOLDING TIME ¹ | CONTAINER ¹ | METHOD |
|---|--|---------------------------|------------------------|---|
| Alkalinity | Filtration, 4° C | In field, 14 days | HDPE bottle | EPA 310.1 APHA ² 2320 |
| Dissolved Anions: Bromide, Chloride | Filtration, 4° C | 28 days | HDPE bottle | EPA 300.0 APHA 4110B |
| Dissolved Metals: Calcium, Sodium | Filtration, 4° C, HNO ₃ < pH 2 | 6 months | HDPE bottle | EPA 200.8 APHA 3120B |
| Total CO ₂ | Filtration, 4° C | 14 days | HDPE bottle | APHA 4500- CO ₂ D Orion, 1990 or ASTM D513-06 |

Note 1: USEPA, Methods for Chemical Analysis of Water and Wastes, EPA-600/4-79-020

Note 2: American Public Health Association, Standard Methods for the Examination of Water and Wastewater

Sample Analysis

Sample analysis will be performed by a National Environmental Laboratory Accreditation Program (NELAP) accredited laboratory except in the case of Total CO₂. Anion concentrations will be determined by ion chromatography (O'Dell et al., 1984, EPA Method 300.0), and cation concentrations will be determined by inductively coupled plasma (ICP) spectrophotometry, (e.g., EPA Method 200.8; APHA, 2005). Alkalinity will be determined using APHA Method 2320. Total CO₂ concentrations will be determined preferentially by coulometry per ASTM D513-06 or alternatively by other methods (e.g., Orion, 1990; APHA, 2005).

Quality Assurance/Quality Control (QA/QC)

Field quality assurance will primarily include periodic field duplicates and field blanks. One field duplicate and one field blank will be used per sampling event. Additional field QA/QC measures will be implemented according to ASTM Method D7069-04 (2004) as needed based on data analysis of historical results and laboratory performance during the monitoring program.

Sample Chain of Custody

All sample bottles will be labeled with durable labels and indelible markings. A unique sample identification number, sampling date, and analyte(s) will be recorded on the sample bottles as well as sampling records written for each well. Sampling records (e.g., a field logbook, individual well sampling sheet) will indicate the sampling personnel, date, time, sample

location/well, unique sample identification number, collection procedure, measured field parameters, and additional comments as needed.

A chain-of-custody record shall be completed and accompany every sample or group of samples collected during an individual sampling event to track sample custody. This record should include: sampler name(s), their affiliation, address, phone number, project identification and project location, sample(s) identification number(s), sampling date and time, signature of person(s) involved in chain-of-custody possession, and remarks regarding sample(s). Where appropriate, ASTM Method D6911-03 (2003) will be followed for packaging and shipping of samples. Immediately upon sample collection, containers shall be placed in an insulated cooler and cooled to 4 degrees Celsius. Samples will either be shipped or hand delivered. Shipment priority will be determined by the holding times or need to expedite sample analysis. Upon receipt at the laboratory, the samples will be accepted and tracked by the laboratory from arrival through completed analysis.

Groundwater Quality Evaluation

Data validation will include the review of the concentration units, sample holding times, and the review of duplicate, blank and other appropriate QA/QC results. All groundwater quality results will be entered into a database or spreadsheet with periodic data review and analysis. Copies of analytical reports from the NELAP laboratory will be kept on file at the ISGS for the duration of the project. Analytical results from the NELAP laboratory will be reported quarterly based on the approved UIC permit conditions. In the quarterly reports, data will be presented in graphical and tabular formats as appropriate to characterize general groundwater quality and identify intrawell variability with time. After sufficient data have been collected, additional methods consistent with the USEPA 2009 Unified Guidance (USEPA, 2009) will be used to evaluate intrawell variations for each groundwater constituent to evaluate if significant changes have occurred that could be the result of CO₂ or brine seepage.

F.5. References

APHA, 2005, *Standard methods for the examination of water and wastewater (21st edition)*, American Public Health Association, Washington, DC.

ASTM, 2010, Method D7069-04 (reapproved 2010), *Standard guide for field quality assurance in a ground-water sampling event*, ASTM International, 100 Barr Harbor Drive, West Conshohocken, PA.

ASTM, 2010, Method D6911-03 (reapproved 2010), *Standard guide for packaging and shipping environmental samples for laboratory analysis*, ASTM International, 100 Barr Harbor Drive, West Conshohocken, PA.

ASTM, 2005, Method D6517-00 (reapproved 2005), *Standard guide for field preservation of ground-water samples*, ASTM International, 100 Barr Harbor Drive, West Conshohocken, PA.

ASTM, 2005, Method D6564-00 (reapproved 2005), *Standard guide for field filtration of ground-water samples*, ASTM International, 100 Barr Harbor Drive, West Conshohocken, PA.

ASTM, 2005, Method D6452-99 (reapproved 2005), *Standard Guide for Purging Methods for Wells Used for Ground-Water Quality Investigations*, ASTM International, 100 Barr Harbor Drive, West Conshohocken, PA.

ASTM, 2002, Method D513-02, *Standard test methods for total and dissolved carbon dioxide in water*, ASTM International, 100 Barr Harbor Drive, West Conshohocken, PA.

ASTM, 2002, Method D6771-02, *Standard guide for low-flow purging and sampling for wells and devices used for ground-water quality investigations*, ASTM International, 100 Barr Harbor Drive, West Conshohocken, PA.

Gibb, J.P., R.M. Schuller, and R.A. Griffin, 1981, *Procedures for the collection of representative water quality data from monitoring wells*, Illinois State Geological Survey Cooperative Groundwater Report 7, Champaign, IL, 61 p.

Larson, D.R., B.L. Herzog and T.H. Larson, 2003. *Groundwater geology of DeWitt, Piatt, and Northern Macon Counties, Illinois*. Illinois State Geological Survey Environmental Geology 155, 35 p.

O'Dell, J. W., J. D. Pfaff, M. E. Gales, and G. D. McKee, 1984, *Test Method- The Determination of Inorganic Anions in Water by Ion Chromatography-Method 300*, U.S. Environmental Protection Agency, EPA-600/4-84-017.

Orion Research Inc., 1990, *CO₂ Electrode Instruction Manual*, Orion Research Inc., 36 p.

Puls, R.W., and M.J. Barcelona, 1996, *Low-Flow (Minimal Drawdown) Ground-Water Sampling Procedures*. U.S. Environmental Protection Agency, EPA-540/S-95/504.

US EPA, 2009, *Statistical analysis of groundwater monitoring data at RCRA facilities – Unified Guidance*, US EPA, Office of Solid Waste, Washington, DC.

US EPA, 1974, *Methods for chemical analysis of water and wastes*, US EPA Cincinnati, OH, EPA-625-/6-74-003a.

Wood, W. W., 1976, *Guidelines for collection and field analysis of groundwater samples for selected unstable constituents*, In U.S. Geological Survey, *Techniques for Water Resources Investigations*, Chapter D-2, 24 p.

APPENDIX G

APPENDIX G – Procedures for Testing Mechanical Integrity

Procedures for Testing Mechanical Integrity:

Pressure Testing Techniques

Objective: To verify the “absence of significant leaks”

Initial tests

To be completed during the installation of well completion as per standard and best completion practices. Procedure will begin at the point of installing final injection string with injection packer or seal assembly if PBR (polished bore receptacle) and seal assembly is being used. Well will already be filled with packer fluid at this time.

1. Pick up packer/seal assembly, any profile nipples, and injection tubing along with any subsurface monitor equipment and control lines if required.
2. Injection tubing will be tested while being run into well or by using blanking plug after being run into well as deemed most appropriate. Space out string and either string into PBR with seal assembly or set injection packer.
3. Land tubing in wellhead with tubing hanger. Nipple down Nipple up well head. Test the casing-tubing annulus side for one hour to 1000 psig. Record test using National Institute of Standards and Technology (NIST) certified and calibrated recorder. A test will be deemed successful if a pressure decline of less than 3% is observed. Any significant pressure drop will be investigated to verify that mechanical integrity is intact and corrected as necessary. Pressure test will be re-run following investigation / remediation to confirm integrity.
4. The data obtained, including recorded charts from the tests, shall be submitted as required by the UIC permit.

Subsequent Tests

To be completed following a period of CO₂ injection.

1. Stop injection and allow well to stabilize
2. Connect NIST certified and calibrated pressure recorder to tubing – casing annulus.
3. Using annular pressure control pump increase injection pressure to 1000 psig.
4. Monitor pressure over a 1 hour period. A test will be deemed successful if less than 3% pressure drop is observed over one hour.
5. If a significant pressure drop is observed it will be investigated to verify that mechanical integrity is intact and corrected as necessary. Pressure test will be re-run following investigation / remediation to confirm integrity.
6. The data obtained, including recorded charts from the tests and volume of liquid used, shall be submitted as required by the UIC permit.

Continual Monitoring

During the injection timeframe of the project, the casing-tubing pressure will be monitored and recorded real time. Surface pressure of the casing-tubing annulus is anticipated to be from 400 to 700 psi. Any significant change of casing-tubing annular pressure that can be related to mechanical integrity issues will be investigated as a possible leak in one of four areas:

- Casing - from the surface to the packer
- Tubing string - from the surface to the packer
- Packer seal
- Tree

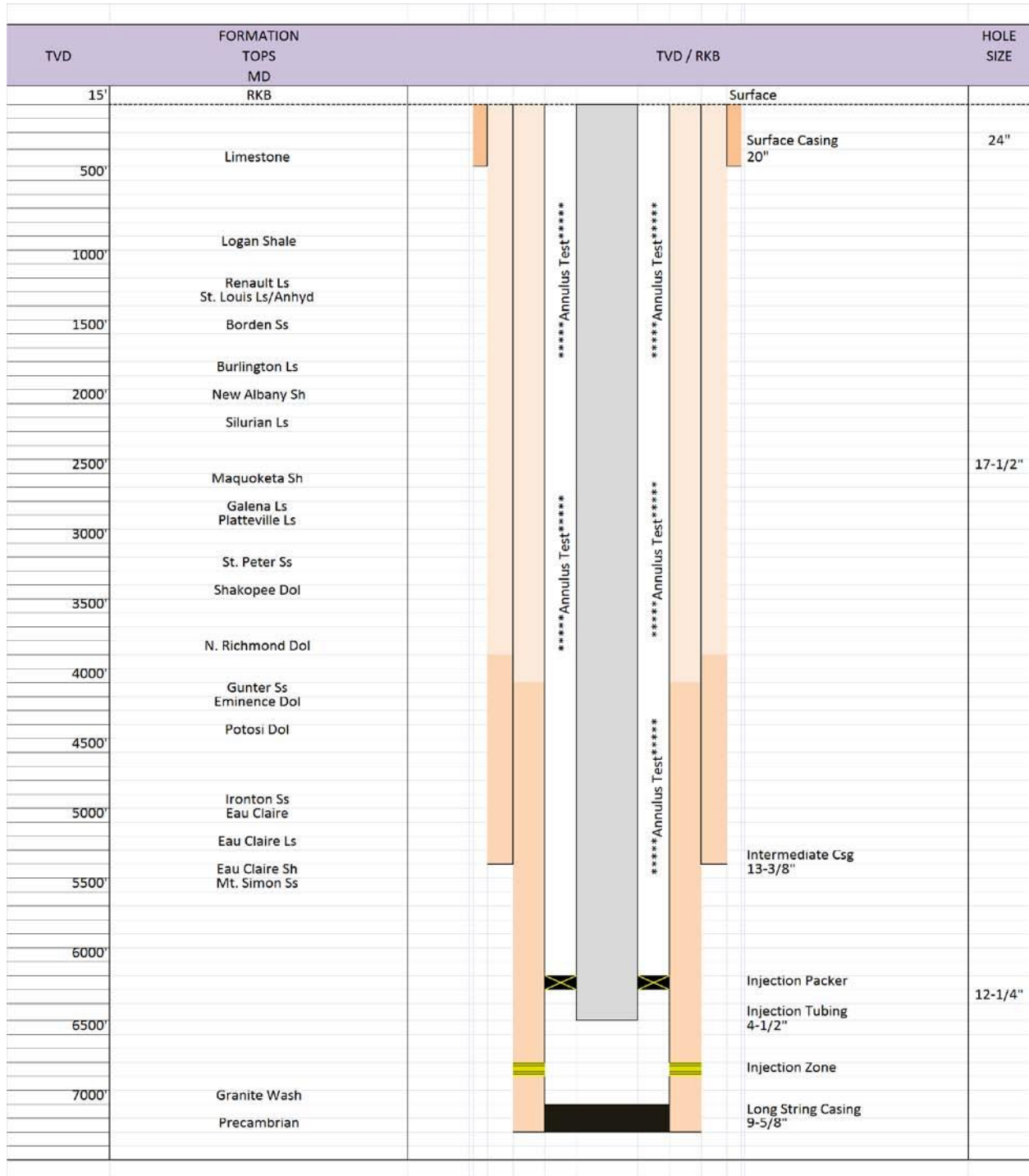

Figure G-1 - Schematic diagram of injection well showing annulus to be tested for mechanical integrity.

Procedures for Testing Mechanical Integrity: Time-Lapse Sigma Logging and Temperature Surveys

Objective: To verify the “absence of significant fluid movement”

Initial Survey - Time Lapse Sigma Logs

To be completed before CO₂ Injection with the tubing and annular fluid level at least to the Maquoketa Formation:

1. Move in and rig up electric logging unit with pressure control
2. Run base RST Sigma Log from TD to surface
3. Rig down the logging equipment
4. Process and archive data as baseline

Subsequent Surveys - Time Lapse Sigma Logs

To be completed following a period of CO₂ injection, with the well in a static condition and fluid level to the Maquoketa Formation or higher:

1. Move in and rig up electric logging unit with lubricator
2. Run RST Sigma Log from TD thru at least the Maquoketa Formation
3. Rig down the logging equipment
4. Process the data and compare to baseline log noting any changes in Sigma that can be attributed to CO₂
5. Should CO₂ migration be interpreted in the top most section of the log, additional logging runs will be required to find the top of migration
6. The data obtained shall be submitted as required by the permit.

Post Injection Temperature Surveys

Well should be in a state of injection for at least 6 hours prior to commencing operations in order to cool injection zones.

1. Move in and rig up an electrical logging unit with lubricator
2. Run a temperature survey from the Base of the Maquoketa Formation (or higher) to the deepest point reachable in the Mt. Simon while injecting at a rate that allows for safe operations.*
3. Stop injection, pull tool back to shallow depth, wait 1 hour.
4. Run a temperature survey over the same interval as step 2.
5. Pull tool back to shallow depth, wait 2 hours
6. Run a temperature survey over the same interval as step 2.
7. Pull tool back to shallow depth, wait 2 hours
8. Run a temperature survey over the same interval as step 2

9. Evaluate data to determine if additional passes are needed for interpretation. Should CO₂ migration be interpreted in the top most section of the log, additional logging runs over a higher interval will be required to find the top of migration
10. Rig down the logging equipment
11. Overlay data and interpret which zones are open to injection.
12. The data obtained shall be submitted as required by the permit.

*Should operation constraints or safety concerns not allow for a logging pass while injecting; an acceptable, alternate plan is to stop injecting immediately prior to the first logging pass.

APPENDIX H

APPENDIX H - Emergency and Remedial Response Plan

EMERGENCY AND REMEDIAL RESPONSE PLAN

This plan is provided to meet the requirements of 40 C FR 146.94. As steps to prevent unexpected CO₂ movement have already been undertaken in accordance with risk analysis, this plan is about actions to be taken, and to be prepared to take, if the unexpected movement occurs anyway.

Facility Name: Archer Daniels Midland Company (ADM)
Illinois Industrial Carbon Capture & Storage (IL-ICCS) Project

Facility Contacts: A site-specific list of facility contacts will be developed and maintained during the life of the project.

Injection Well Location: Near the center of Section 32
Township 17N, Range 3E (Whitmore Township)
Decatur, Macon County, Illinois

This emergency and remedial response plan (ERRP) describe actions that the owner / operator (ADM) shall take to address movement of the injection fluid or formation fluid in a manner that may endanger an underground source of drinking water (USDW) during construction, operation, or post-injection site care periods.

By Federal regulation, if ADM obtains evidence that the injected carbon dioxide (CO₂) stream and/or associated pressure front may endanger a USDW, ADM must perform the following actions:

1. Immediately shut down the injection well.
2. Take all steps reasonably necessary to identify and characterize the release.
3. Notify the permitting agency (UIC Program Director) of the event within 24 hours.
4. Implement the approved ERRP.

Please note: A preliminary outline for the development of a plan for various contingencies follows this ERRP. This Contingency Plan is to be formally developed during the Permit Review Period.

Part 1: Local Resources and Infrastructure. Resources in the vicinity of the IL-ICCS project that may be impacted as a result of an emergency at the project site include: underground sources of drinking water (USDWs); potable water wells; the Sangamon River; Bois Du Sangamon Nature Preserve; and Lake Decatur.

Infrastructure in the vicinity of the IL-ICCS project that may be impacted as a result of an emergency at the project site include: Richland Community College; various residential areas, commercial properties, and recreational facilities; and ADM corn processing facilities.

A map of the local area is provided as Figure H-1 at the end of this plan.

Part 2: Potential Risk Scenarios. The following events related to the IL-ICCS project could potentially result in an emergency response:

- Injection or monitoring (verification) well integrity failure;
- Injection well monitoring equipment failure (e.g., shut-off valve, pressure gauge, etc.)
- A natural disaster (e.g., earthquake, tornado, lightning strike);
- Fluid (e.g. brine) leakage to a USDW;
- Carbon dioxide leakage to USDW or land surface.

Response actions will depend on the severity of the event(s) triggering an emergency response. Emergency events will be defined as follows:

| TABLE H-1. DEFINITION OF EMERGENCY CONDITIONS | |
|--|---|
| Emergency Condition | Definition |
| Major Emergency | Event poses immediate risk to human health, resources, or infrastructure. Emergency actions involving local authorities (evacuation or isolation of areas) should be initiated. |
| Serious Emergency | Event poses potential risk to human health, resources, or infrastructure if conditions worsen or no response actions taken. |
| Minor Emergency | Event poses no immediate risk to human health, resources, or infrastructure. |

In the event of an emergency requiring cessation of injection, CO₂ slated for injection may be released to the atmosphere.

Part 3: Emergency Identification and Response Actions. Steps to identify and characterize the event will be dependent on the specific issue identified, and the severity of the event. The potential risk scenarios identified in Part 2 are detailed below.

In the event of an emergency requiring outside assistance, the project contact lead shall call the ADM Security Dispatch at (217) 424-4444.

Well Integrity Failure.

Integrity loss of the injection well and/or verification well may endanger USDWs or surface areas. Integrity loss may have occurred if the following events occur:

- a. Automatic shutdown devices are activated. (**NOTE: The activation of an automatic shutdown device does not, in itself, constitute an emergency event.**)
 - Wellhead pressure exceeds the shutdown pressure (2,380 psi);
 - Mass flow rate of CO₂ exceeds the daily limit (3,300 metric tonnes per day);
 - Surface temperature varies outside the permitted range;
 - Annulus pressure varies outside of the permitted range (<500 psi or >600 psi);
- b. Mechanical integrity test results identify abnormal results.

Response Actions:

- Immediately notify the ADM and other designated project contacts.
- Project contacts will determine the severity of the event, based on the information available, within 24 hours of notification.
- Notify the UIC Program Director within 24 hours of the incident, if event meets the definition of an “emergency” condition.
- For a Major or Serious Emergency:
 - Cease injection immediately.
 - Shut in well (close flow valve). Vent CO₂ from surface facilities.
 - Limit access to wellhead to authorized personnel only.
 - Communicate with Corn Plant personnel and local authorities to initiate evacuation plans, as necessary.
 - Monitor well pressure, temperature, annulus pressure to verify integrity loss and determine the cause and extent of failure.
- For a Minor Emergency:
 - Cease injection immediately.
 - Shut in well (close flow valve). Vent CO₂ from surface facilities.
 - Reset automatic shutdown devices.
 - Monitor well pressure, temperature, annulus pressure to verify integrity loss and determine the cause and extent of failure.

Injection Well Monitoring Equipment Failure.

The failure of monitoring equipment for wellhead pressure, temperature, and/or annulus pressure may indicate a problem with the injection well that could endanger USDWs. (**NOTE: The failure of monitoring equipment does not, in itself, constitute an emergency event.**)

Response Actions:

- Immediately notify the ADM and other designated project contacts.
- Project contacts will determine the severity of the event, based on the information available, within 24 hours of notification.
- Notify the UIC Program Director within 24 hours of the incident, if event meets the definition of an “emergency” condition.
- For a Major or Serious Emergency:

- Cease injection immediately.
- Shut in well (close flow valve). Vent CO₂ from surface facilities.
- Limit access to wellhead to authorized personnel only.
- Communicate with Corn Plant personnel and local authorities to initiate evacuation plans, as necessary.
- Monitor well pressure, temperature, annulus pressure (manually if necessary) to determine the cause and extent of failure.
- For a Minor Emergency:
 - Cease injection immediately.
 - Shut in well (close flow valve). Vent CO₂ from surface facilities.
 - Reset or repair automatic shutdown devices.
 - Monitor well pressure, temperature, annulus pressure (manually if necessary) to determine the cause and extent of failure.

Potential CO₂ Leakage to Land Surface. Elevated concentrations of CO₂ or other evidence of CO₂ leakage to the land surface are detected.

Response Actions:

- Immediately notify the ADM and other designated project contacts.
- Project contacts will determine the severity of the event, based on the information available, within 24 hours of notification.
- Notify the UIC Program Director within 24 hours of the incident, if event meets the definition of an “emergency” condition.
- For all Emergencies (Major, Serious, and Minor):
 - Cease injection immediately.
 - Shut in well (close flow valve). Vent CO₂ from surface facilities.
 - Limit access to wellhead to authorized personnel only.
 - Communicate with Corn Plant personnel and local authorities to initiate evacuation plans, as necessary.
 - If suspected release is from the wellhead, take steps to plug well, and repair, if possible. If release is significant (i.e., a well “blowout”), take steps to kill well.
 - If suspected release is away from well head, take steps to log well to detect CO₂ movement outside of casing.
 - Isolate the suspected release area with the assistance of local authorities, if necessary.
 - Use trained personnel to inspect the suspected release area and conduct CO₂ air monitoring at the suspected release point, or, if a larger area, establish a sampling grid within the suspected release area and monitor at sample grid points.
 - If a release point is not identified from the above actions, perform additional CO₂ air measurements within the sampling grid.
 - Use collected data to pinpoint the suspected release area.
 - Establish a restricted area around the release with the assistance of local authorities, if necessary.
 - Take appropriate steps to dilute and vent the CO₂ release.

- Continue monitoring within the release area until monitoring data indicate that the release has been mitigated.

Potential Brine or CO₂ Leakage to USDW. Elevated concentrations of indicator parameter(s) in groundwater sample(s) or other evidence of fluid (brine) or CO₂ leakage into a USDW.

Response Actions:

- Immediately notify the ADM and other designated project contacts.
- Project contacts will determine the severity of the event, based on the information available, within 24 hours of notification.
- Notify the UIC Program Director within 24 hours of the incident, if event meets the definition of an “emergency” condition.
- For all Emergencies (Major, Serious, or Minor):
 - Cease injection immediately.
 - Shut in well (close flow valve). Vent CO₂ from surface facilities.
 - Collect a confirmation sample(s) of groundwater and analyze for indicator parameters.
 - If the presence of indicator parameters are confirmed, develop a case-specific work plan to
 - a. install additional groundwater monitoring points near the impacted groundwater well(s) to delineate the extent of impact; and
 - b. remediate impacts to the impacted USDW.
 - Arrange for an alternate potable water supply, if the USDW was being utilized.
 - Proceed with efforts to remediate USDW (e.g., install system to intercept/extract brine or CO₂, “pump and treat” to aerate CO₂-laden water, etc.).
 - Continue groundwater remediation, monitoring on a frequent basis (frequency to be determined by ADM and the UIC Program Director) until USDW impact has been fully addressed.

Natural Disaster. Well problems (integrity loss, leakage, or malfunction) may arise as a result of a natural disaster impacting the normal operation of the injection well. An earthquake may disturb surface and/or subsurface facilities; weather-related disasters (e.g., tornado or lightning strike) may impact surface facilities.

If a natural disaster occurs that affects normal operation of the injection well, perform the following:

Response Actions:

- Immediately notify the ADM and other designated project contacts.
- Project contacts will determine the severity of the event, based on the information available, within 24 hours of notification.
- Notify the UIC Program Director within 24 hours of the incident, if event meets the definition of an “emergency” condition.

- For a Major or Serious Emergency:
 - Cease injection immediately.
 - Shut in well (close flow valve). Vent CO₂ from surface facilities.
 - Limit access to wellhead to authorized personnel only.
 - Communicate with Corn Plant personnel and local authorities to initiate evacuation plans, as necessary.
 - Monitor well pressure, temperature, annulus pressure to verify well status and determine the cause and extent of any failure.
- For a Minor Emergency:
 - Cease injection immediately.
 - Shut in well (close flow valve). Vent CO₂ from surface facilities.
 - Limit access to wellhead to authorized personnel only.
 - Monitor well pressure, temperature, annulus pressure to verify integrity loss and determine the cause and extent of any failure.

Part 4: Response Personnel and Equipment

Site personnel, project personnel, and local authorities will be relied upon to implement this ERRP. The injection well and areas to the west and southwest are located within the limits of the City of Decatur; however, adjacent areas to the southeast, east, and north are outside of city limits. Therefore, both city and county emergency responders (as well as state agencies) may need to be notified in the event of an emergency.

Site personnel:

ADM Project Engineer
 ADM Corn Plant Environmental Manager
 ADM Plant Manager, Plant Superintendent, or General Foreman
 ADM Corporate Communications Contact

Project personnel:

Subcontractor Project Manager(s)

Local Authorities: including (but not limited to)

City of Decatur Police Department
 City of Decatur Fire Department
 Macon County Sheriff
 Illinois State Police
 Macon County Emergency Management Agency
 Illinois Emergency Management Agency

Equipment needed in the event of an emergency and remedial response will vary, depending on the triggering emergency event. Response actions (cessation of injection, well shut-in, and evacuation) will generally not require specialized equipment to implement. Where specialized equipment (such as a drilling rig) is required, the designated Subcontractor Project Manager shall be responsible for its procurement.

Part 5: Emergency Communications Plan

In the event of an emergency requiring outside assistance, the project contact lead shall call the ADM Security Dispatch at (217) 424-4444.

A site-specific emergency contact list will be developed and maintained during the life of the project.

Emergency communications with the public will be handled by ADM Corporate Communications. The individual to be designated by ADM will be the first contact during an emergency event. This individual will contact the crisis communication team as appropriate. Emergency responses to the media will be dealt with ONLY by the personnel so designated by ADM. Those individuals should try to be reachable 24 hours a day for contact in the event of an emergency.

In the event that anyone else is contacted to comment on any situation deemed an “emergency”, the media contact should be directed to the ADM-designated individual, who will oversee all media communications with the public (through either interview, press release, Web posting, or other) in the event of an emergency situation related to the injection project.

Part 6: Plan Review

This ERRP shall be reviewed:

- at least once every five (5) years following its approval by the permitting agency,
- within one (1) year of an area of review (AOR) re-evaluation,
- within a prescribed period (to be determined by the permitting agency) following any significant changes to the injection process or injection facility, or
- as required by the permitting agency.

If the review indicates that no amendments to the ERRP are necessary, provide the permitting agency with the documentation supporting the “no amendment necessary” determination.

If the review indicates that amendments to the ERRP are necessary, amendments shall be made and submitted to the permitting agency within six (6) months following an event that initiates the ERRP review procedure.

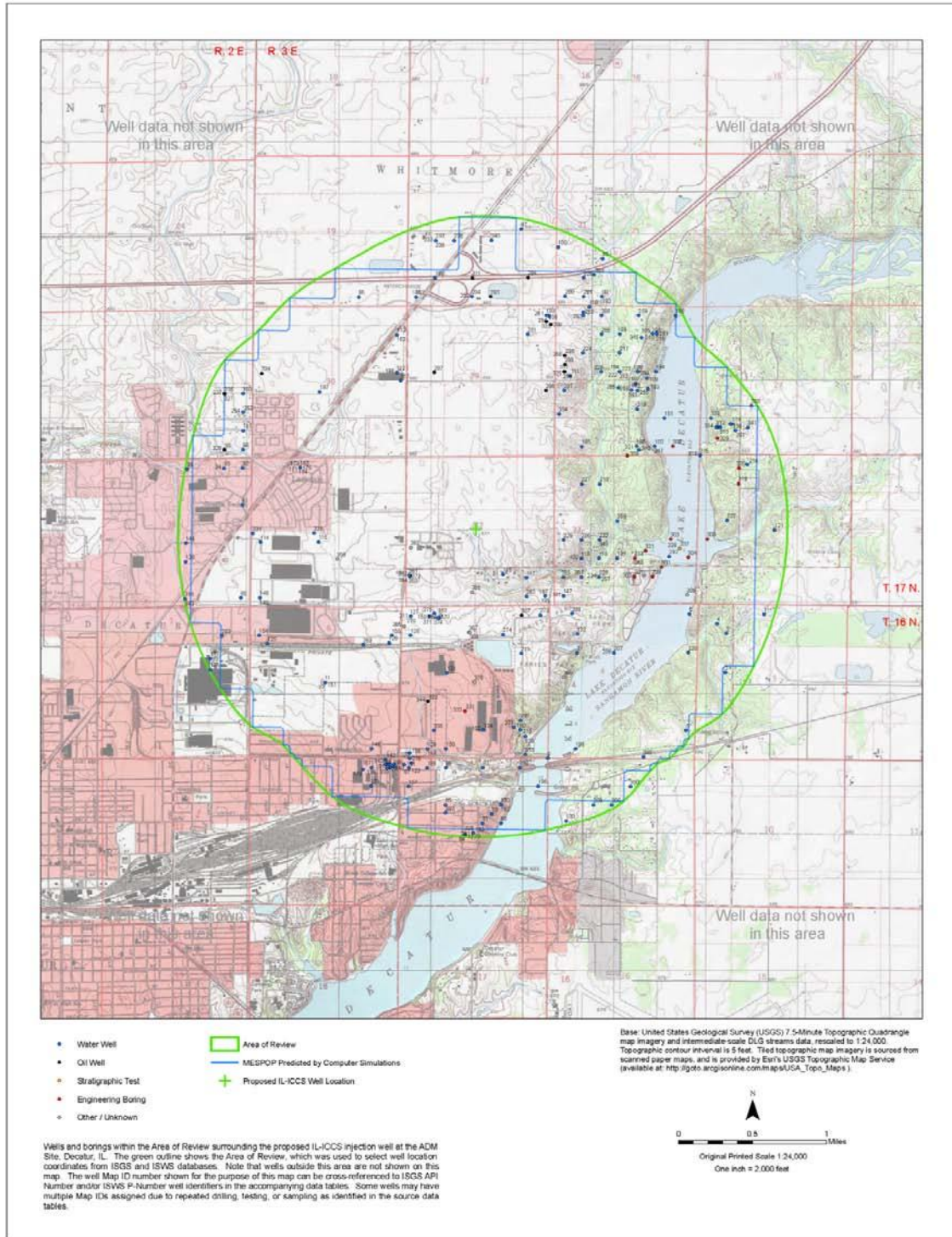

Figure H-1. Local area map for the IL-ICCS project. Emergency & remedial response activities will most likely be within the “area of review” highlighted on the map. This map illustrates the resources and infrastructure in the vicinity of the IL-ICCS project. ADM Corn Plant facilities are south of the injection well, Richland Community College is west. The closest residential/commercial/industrial areas are to the east of the injection well. Lake Decatur / Sangamon River and natural / recreational areas are generally east to southeast of the injection well. Source: ISGS and ISWS well databases, current as of May 10, 2011.



| | | | |
|---|-------------------------------------|------------------------|-------------------------|
| Monitoring, Reporting, and Verification Plan CCS#2 | | | |
| Date Issued 3/21/2024 | Document # 180.60.ENV.309 | Version 10.0 | Page 36 of 37 |

SUMMARY OF PREVIOUS REVISIONS

| Date | Version | Author | Reason(s) for revision |
|------------|---------|------------------------------|--|
| 01/06/2016 | 1.0 | Outzen | New Document |
| 01/07/2016 | 2.0 | Outzen | Minor Formatting changes. |
| 01/09/2017 | 3.0 | Outzen | Modified Reference 1. Removed References 3, 4, and 5. Updated figure 2 to reflect current Active Monitoring Area. Updated Table 1. Update Section 9.1.2.4 to reflect current monitoring practice. Updated Section 10 to reflect current practice. Updated Section 12 to reflect current implementation schedule. Minor formatting and grammar corrections. |
| 03/16/2018 | 4.0 | Neisslie | Corrected a section number that was referenced in section 11.0 to the correction section number. It was changed to 9.3 from 5.3. |
| 03/23/2021 | 5.0 | Feltes/Neisslie | Set review period to 36 months. Added an amended Figure 2 showing the new Area of Review boundary. |
| 3/29/2022 | 6.0 | Neisslie | Made corrections to tables and edits on the injection timeline and associated actions. Updated the maximum monitoring area delineation. Review period changed to annually. |
| 3/29/2023 | 7.0 | Neisslie | Updated language in section 8.3 regarding survey data associated with the IBDP and IL-ICCS projects confirming the lack of significant faults or folds through the sealing formation. Updated language in section 8.5 regarding mitigation measures to be implemented for mitigating leaks until remediation can be performed. Updated Tables 1 and 2 to include all shallow and deep monitoring wells with updated depths based on ISGS reports. |
| 6/19/2023 | 8.0 | D. Maity/S. Kazarian/M. Khan | Updated section 9.1.2.3 to include emergency response and risk assessment associated with seismic events. Updated the title of section 11.0, revised section 11.0 to include CO ₂ received calculations. Updated headings and created a table of contents. Added the well ID number in section 2.0. Added a geologic setting description in Section 6.0. Added process flow diagrams in section 7.0. Updated language surrounding the MMA v AMA in section 7.0. Edited the entire document for clarity, grammar and |



| Monitoring, Reporting, and Verification Plan CCS#2 | | | |
|--|----------------|---------|----------|
| Date Issued | Document # | Version | Page |
| 3/21/2024 | 180.60.ENV.309 | 10.0 | 37 of 37 |

| | | | |
|----------|-----|---------------------|--|
| | | | punctuation. Edited section 8.3 and 8.4 to make the MRV a standalone document. |
| 8/7/2023 | 9.0 | S. Kazarian/M. Khan | Reoriented figures 3-1 and 3-2 so they can be displayed with higher resolution. Added additional language concerning the AMA and MMA to clarify the timeline associated with them and why they are the same. |